

The Publishers and the Authors will be grateful to any of the readers of this volume who will kindly call their attention to any errors of omission or of commission that they may find therein. It is intended to make our publications standard works of study and reference, and, to that end, the greatest accuracy is sought. It rarely happens that the early editions of works of any size are free from errors; but it is the endeavor of the Publishers to have them removed immediately upon being discovered, and it is therefore desired that the Authors may be aided in their task of revision, from time to time, by the kindly criticism of their readers.

JOHN WILEY & SONS, Inc.

432 4TH AVENUE.



## WORKS OF WILLIAM KENT

PUBLISHED BY

JOHN WILEY & SONS.

---

### **The Mechanical Engineers' Pocket-Book.**

A Reference Book of Rules, Tables, Data, and Formulæ, for the Use of Engineers, Mechanics, and Students. Ninth edition. Thoroughly revised with the assistance of Robert T. Kent. xlv + 1526 pages, 4 by 6  $\frac{3}{4}$ . Leather, \$5.00 net.

### **Steam-Boiler Economy.**

A treatise on the Theory and Practice of Fuel Economy in the Operation of Steam-Boilers. Second edition, 1915. xvii + 717 pages, 6 by 9. 287 figures, cloth, \$4.50 net.

### **Investigating an Industry.**

A Scientific Diagnosis of the Diseases of Management. With an introduction by Henry L. Gantt, author of "Work, Wages and Profits." xi + 126 pages, 5 by 7  $\frac{1}{4}$ , cloth, \$1.00 net.

✓  
THE  
MECHANICAL ENGINEERS'  
POCKET-BOOK. ✓

A REFERENCE-BOOK OF RULES, TABLES,  
DATA, AND FORMULÆ.

✓ BY

✓ WILLIAM KENT, M. E., Sc.D.,

*Consulting Engineer.*

*Member Amer. Soc'y Mechl. Engrs. and Amer. Inst. Mining Engrs.*

✓ NINTH EDITION, ✓ THOROUGHLY ✓ REVISED

WITH THE ASSISTANCE OF

✓ ROBERT THURSTON KENT, M. E.,

*Consulting Engineer.*

*Junior American Society of Mechanical Engineers.*

**TOTAL ISSUE, ONE HUNDRED AND EIGHT THOUSAND.**

NEW YORK  
JOHN WILEY & SONS, INC.  
LONDON: CHAPMAN & HALL, LIMITED

1916

*Copy 2*

T. J. 151  
K 4  
1916  
Cohu 2

COPYRIGHT, 1895, 1902, 1910, 1915,  
BY  
WILLIAM KENT.

*Eighth Edition entered at Stationers' Hall.*

75-00  
© Cl. A 418026

Composition and Electrotyping by the STANHOPE PRESS, Boston, Mass., and  
the PUBLISHERS PRINTING COMPANY, New York.

Printing and Binding by BRAUNWORTH & COMPANY, Brooklyn, N. Y.

DEC 14 1915  
mon.



# PREFACE TO THE NINTH EDITION.

NOVEMBER, 1915.

SINCE the eighth edition was published, five years ago, there have been notable advances in many branches of engineering, rendering obsolete portions of the book which at that time were in accord with practice. In addition, many engineering standards have been changed during the five-year period, necessitating a thorough revision of many sections of the work. The absolutely necessary revisions to bring the book up to date have involved changes in over 400 pages of the eighth edition, and the addition of over 150 pages of new matter. The treatment of many subjects in the earlier edition has been condensed into smaller space to enable the insertion of the new matter without increasing the size of the book to unwieldy proportions. Extensive revisions have been made in the subjects of materials, mechanics, fans and blowers, heating and ventilation, fuel, steam-boilers and engines, and steam-turbines. The chapter on machine-shop practice has been rewritten and doubled in size, and now covers many subjects which were omitted in earlier editions. The new matter includes many data on planing, milling, drilling and grinding, together with an elaborate treatment of the subject of machine-tool driving. The subject of electrical engineering has been completely rewritten and brought into agreement with present practice. Of the new tables added the following are considered of special importance. Square roots of fifth powers; Four-place logarithms; Standard sizes of welded steel pipe; Standard pipe flanges; Properties of wire rope; Fire brick and other refractories; Properties of structural sections and columns; Chemical standards for iron castings; Flow of air, water and steam; Analyses and heating values of coals; Rankine efficiency; Cooling towers; Properties of ammonia; Power required for driving machine tools of all types, both singly and in groups; Electric resistance and conductivity of wires; Street railway installation; Electric lamp characteristics; Illuminating data.

## ABSTRACT FROM PREFACE TO THE FIRST EDITION, 1895.

MORE than twenty years ago the author began to follow the advice given by Nystrom: "Every engineer should make his own pocket-book, as he proceeds in study and practice, to suit his particular business." The manuscript pocket-book thus begun, however, soon gave place to more modern means for disposing of the accumulation of engineering facts and figures, viz., the index rerum, the scrap-book, the collection of indexed envelopes, portfolios and boxes, the card catalogue, etc. Four years ago, at the request of the publishers, the labor was begun of selecting from this accumulated mass such matter as pertained to mechanical engineering, and of condensing, digesting, and arranging it in form for publication. In addition to this, a careful examination was made of the transactions of engineering societies, and of the most important recent works on mechanical engineering, in order to fill gaps that might be left in the original collection, and insure that no important facts had been overlooked.

Some ideas have been kept in mind during the preparation of the Pocket-book that will, it is believed, cause it to differ from other works of its class. In the first place it was considered that the field of mechanical engineering was so great, and the literature of the subject so vast, that as little space as possible should be given to subjects which especially belong to civil engineering. While the mechanical engineer must continually deal with problems which belong properly to civil engineering, this latter branch is so well covered by Trautwine's "Civil Engineer's Pocket-book" that any attempt to treat it exhaustively would not only fill no "long-felt want," but would occupy space which should be given to mechanical engineering.

Another idea prominently kept in view by the author has been that he would not assume the position of an "authority" in giving rules and formulæ for designing, but only that of compiler, giving not only the name of the originator of the rule, where it was known, but also the volume and page from which it was taken, so that its derivation may be traced when desired. When different formulæ for the same problem have been found they have been given in contrast, and in many cases examples have been calculated by each to show the difference between them. In some cases these differences are quite remarkable, as will be seen under Safety-valves and Crank-pins. Occasionally the study of these differences has led to the author's devising a new formula, in which case the derivation of the formula is given.

Much attention has been paid to the abstracting of data of experiments from recent periodical literature, and numerous references to other data are given. In this respect the present work will be found to differ from other Pocket-books.

The author desires to express his obligation to the many persons who have assisted him in the preparation of the work, to manufacturers who

have furnished their catalogues and given permission for the use of their tables, and to many engineers who have contributed original data and tables. The names of these persons are mentioned in their proper places in the text, and in all cases it has been endeavored to give credit to whom credit is due.

WILLIAM KENT.

---

## PREFACE TO THE EIGHTH EDITION.

SEPTEMBER, 1910.

DURING the first ten years following the issue of the first edition of this book, in 1895, the attempt was made to keep it up to date by the method of cutting out pages and paragraphs, inserting new ones in their places, by inserting new pages lettered a, b, c, etc., and by putting some new matter in an appendix. In this way the book passed to its 7th edition in October, 1904. After 50,000 copies had been printed it was found that the electro-typed plates were beginning to wear out, so that extensive resetting of type would soon be necessary. The advances in engineering practice also had been so great that it was evident that many chapters required to be entirely rewritten. It was therefore determined to make a thorough revision of the book, and to reset the type throughout. This has now been accomplished after four years of hard labor. The size of the book has increased over 300 pages, in spite of all efforts to save space by condensation and elision of much of the old matter and by resetting many of the tables and formulæ in shorter form. A new style of type for the tables has been designed for the book, which is believed to be much more easily read than the old.

The thanks of the author are due to many manufacturers who have furnished new tables of materials and machines, and to many engineers who have made valuable contributions and helpful suggestions. He is especially indebted to his son, Robert Thurston Kent, M.E., who has done the work of revising manufacturers' tables of materials and has done practically all of the revising of the subjects of Compressed Air, Fans and Blowers, Hoisting and Conveying, and Machine Shop.



THE UNIVERSITY OF CHICAGO  
LIBRARY

THE UNIVERSITY OF CHICAGO

THE UNIVERSITY OF CHICAGO  
LIBRARY

THE UNIVERSITY OF CHICAGO  
LIBRARY

# CONTENTS.

(For Alphabetical Index see page 1479.)

## MATHEMATICS.

### Arithmetic.

	PAGE
Arithmetical and Algebraical Signs.....	1
Greatest Common Divisor.....	2
Least Common Multiple.....	2
Fractions.....	2
Decimals.....	3
Table. Decimal Equivalents of Fractions of One Inch.....	3
Table. Products of Fractions expressed in Decimals.....	4
Compound or Denominate Numbers.....	5
Reduction Descending and Ascending.....	5
Decimals of a Foot Equivalent to Fractions of an Inch.....	5
Ratio and Proportion.....	6
Involution, or Powers of Numbers.....	7
Table. First Nine Powers of the First Nine Numbers.....	7
Table. First Forty Powers of 2.....	8
Evolution. Square Root.....	8
Cube Root.....	9
Alligation.....	9
Permutation.....	10
Combination.....	10
Arithmetical Progression.....	10
Geometrical Progression.....	11
Percentage, Profit and Loss, Efficiency.....	12
Interest.....	12
Discount.....	13
Compound Interest.....	13
Compound Interest Table, 3, 4, 5, and 6 per cent.....	14
Equation of Payments.....	14
Partial Payments.....	14
Annuities.....	15
Tables of Amount, Present Values, etc., of Annuities.....	15

### Weights and Measures.

Long Measure.....	17
Old Land Measure.....	17
Nautical Measure.....	17
Square Measure.....	18
Solid or Cubic Measure.....	18
Liquid Measure.....	18
The Miners' Inch.....	18
Apothecaries' Fluid Measure.....	18
Dry Measure.....	19
Shipping Measure.....	19
Avoirdupois Weight.....	19
Troy Weight.....	19
Apothecaries' Weight.....	20
To Weigh Correctly on an Incorrect Balance.....	20
Circular Measure.....	20
Measure of Time.....	20

	PAGE
Board and Timber Measure. . . . .	20
Table. Contents in Feet of Joists, Scantlings, and Timber. . . . .	21
French or Metric Measures. . . . .	21
British and French Equivalents. . . . .	22
Metric Conversion Tables. . . . .	23
Compound Units	
of Pressure and Weight. . . . .	27
of Water, Weight and Bulk. . . . .	27
of Air, Weight and Volume. . . . .	27
of Work, Power, and Duty. . . . .	27
of Velocity. . . . .	27
Wire and Sheet Metal Gages. . . . .	28
Circular-mil Wire Gage. . . . .	29, 30
U. S. Standard Wire and Sheet Gage (1893). . . . .	29, 32
Twist-drill and Steel-wire Gages. . . . .	31
Decimal Gage. . . . .	32

### Algebra.

Addition, Multiplication, etc. . . . .	33
Powers of Numbers. . . . .	33
Parentheses, Division. . . . .	34
Simple Equations and Problems. . . . .	34
Equations containing two or more Unknown Quantities. . . . .	35
Elimination. . . . .	35
Quadratic Equations. . . . .	35
Theory of Exponents. . . . .	36
Binominal Theorem. . . . .	37
<b>Geometrical Problems of Construction</b> . . . . .	37
of Straight Lines. . . . .	37
of Angles. . . . .	38
of Circles. . . . .	39
of Triangles. . . . .	41
of Squares and Polygons. . . . .	42
of the Ellipse. . . . .	45
of the Parabola. . . . .	48
of the Hyperbola. . . . .	49
of the Cycloid. . . . .	50
of the Tractrix or Schiele Anti-friction Curve. . . . .	50
of the Spiral. . . . .	51
of Rings inside a Circle. . . . .	51
of Arc of a Large Circle. . . . .	51
of the Catenary. . . . .	52
of the Involute. . . . .	52
of plotting Angles. . . . .	53
<b>Geometrical Propositions</b> . . . . .	53
Degree of a Railway Curve. . . . .	54

### Mensuration, Plane Surfaces.

Quadrilateral, Parallelogram, etc. . . . .	54
Trapezium and Trapezoid. . . . .	54
Triangles. . . . .	54
Polygons. Table of Polygons. . . . .	55
Irregular Figures. . . . .	56
Properties of the Circle. . . . .	57
Values of $\pi$ and its Multiples, etc. . . . .	57
Relations of arc, chord, etc. . . . .	58
Relations of circle to inscribed square, etc. . . . .	59
Formulae for a Circular Curve . . . . .	59
Sectors and Segments. . . . .	60
Circular Ring. . . . .	60
The Ellipse. . . . .	60
The Helix. . . . .	61
The Spiral. . . . .	61
Surfaces and Volumes of Similar Solids. . . . .	61

**Mensuration, Solid Bodies.**

	PAGE
Prism . . . . .	62
Pyramid . . . . .	62
Wedge . . . . .	62
Rectangular Prismoid . . . . .	62
Cylinder . . . . .	62
Cone . . . . .	62
Sphere . . . . .	62
Spherical Triangle . . . . .	63
Spherical Polygon . . . . .	63
The Prismoid . . . . .	63
The Prismoidal Formula . . . . .	63
Polyedron . . . . .	63
Spherical Zone . . . . .	64
Spherical Segment . . . . .	64
Spheroid or Ellipsoid . . . . .	64
Cylindrical Ring . . . . .	64
Solids of Revolution . . . . .	64
Spindles . . . . .	64
Frustum of a Spheroid . . . . .	64
Parabolic Conoid . . . . .	65
Volume of a Cask . . . . .	65
Irregular Solids . . . . .	65

**Plane Trigonometry.**

Solution of Plane Triangles . . . . .	66
Sine, Tangent, Secant, etc. . . . .	66
Signs of the Trigonometric Functions . . . . .	67
Trigonometrical Formulæ . . . . .	68
Solution of Plane Right-angled Triangles . . . . .	69
Solution of Oblique-angled Triangles . . . . .	69

**Analytical Geometry.**

Ordinates and Abscissas . . . . .	70
Equations of a Straight Line, Intersections, etc. . . . .	70
Equations of the Circle . . . . .	71
Equations of the Ellipse . . . . .	71
Equations of the Parabola . . . . .	72
Equations of the Hyperbola . . . . .	72
Logarithmic Curves . . . . .	73

**Differential Calculus.**

Definitions . . . . .	73
Differentials of Algebraic Functions . . . . .	74
Formulæ for Differentiating . . . . .	74
Partial Differentials . . . . .	75
Integrals . . . . .	75
Formulæ for Integration . . . . .	75
Integration between Limits . . . . .	76
Quadrature of a Plane Surface . . . . .	76
Quadrature of Surfaces of Revolution . . . . .	77
Cubature of Volumes of Revolution . . . . .	77
Second, Third, etc., Differentials . . . . .	77
Maclaurin's and Taylor's Theorems . . . . .	78
Maxima and Minima . . . . .	78
Differential of an Exponential Function . . . . .	79
Logarithms . . . . .	79
Differential Forms which have Known Integrals . . . . .	80
Exponential Functions . . . . .	80
Circular Functions . . . . .	81
The Cycloid . . . . .	81
Integral Calculus . . . . .	82

<b>The Slide Rule.</b>		PAGE
Examples solved by the Slide Rule.....		82
<b>Logarithmic Ruled Paper.</b>		
Plotting on Logarithmic Paper.....		84
<b>Mathematical Tables.</b>		
Formula for Interpolation.....		86
Reciprocals of Numbers 1 to 2000.....		87
Squares, Cubes, Square Roots and Cube Roots from 0.1 to 1600		93
Squares and Cubes of Decimals.....		108
Fifth Roots and Fifth Powers.....		109
Square Roots of Fifth Powers of Pipe Sizes.....		110
Circumferences and Areas of Circles.....		111
Circumferences of Circles in Feet and Inches from 1 inch to 32		
feet 11 inches in diameter.....		120
Areas of the Segments of a Circle.....		121
Lengths of Circular Arcs, Degrees Given.....		122
Lengths of Circular Arcs, Height of Arc Given.....		124
Circles and Squares of Equal Area.....		125
Number of Circles Inscribed within a Large Circle.....		125
Spheres.....		126
Square Feet in Plates 3 to 32 feet long and 1 inch wide.....		128
Gallons in a Number of Cubic Feet.....		130
Cubic Feet in a Number of Gallons.....		130
Contents of Pipes and Cylinders, Cubic Feet and Gallons.....		131
Cylindrical Vessels, Tanks, Cisterns, etc.....		132
Capacities of Rectangular Tanks in Gallons.....		133
Number of Barrels in Cylindrical Cisterns and Tanks.....		134
Logarithms.....		135
Table of Logarithms.....		137
Hyperbolic Logarithms.....		164
Four-place Logarithms of Numbers from 1 to 1000.....		167
Natural Trigonometric Functions.....		169
Logarithmic Trigonometric Functions.....		172
<b>Materials.</b>		
Chemical Elements.....		173
Specific Gravity and Weight of Materials.....		173
The Hydrometer.....		175
Metals, Properties of.....		177
Aluminum.....		177
Antimony.....		177
Bismuth.....		178
Cadmium.....		178
Copper.....		178
Gold.....		178
Iridium.....		178
Iron.....		178
Lead.....		178
Magnesium.....		179
Manganese.....		179
Mercury.....		179
Nickel.....		179
Platinum.....		179
Silver.....		179
Tin.....		179
Zinc.....		179
<b>Miscellaneous Materials.</b>		
Order of Malleability, etc., of Metals.....		180
Measures and Weights of Various Materials.....		180



	PAGE
Formulae and Table for Weight of Rods, Plates, etc. . . . .	181
Commercial Sizes of Iron and Steel Bars . . . . .	182
Weights of Iron and Steel Sheets . . . . .	183
of Iron Bars . . . . .	184
of Round Steel Bars . . . . .	185
of Fillets . . . . .	185
of Round, Square, and Hexagon Steel . . . . .	186
of Plate Iron . . . . .	187
of Flat Rolled Iron . . . . .	188
of Steel Blooms . . . . .	190
of Roofing Materials . . . . .	191-196
Snow and Wind Loads on Roofs . . . . .	191
Roof Construction . . . . .	191
Specifications for Tin and Terne Plates . . . . .	194
Corrugated Sheets . . . . .	194
Weights and Thickness of Cast-iron Pipe . . . . .	196-199
Weights of Cast-iron Pipe Columns . . . . .	200
Weight of Open-end Cast-iron Cylinders . . . . .	200
Standard Sizes of Welded Pipe . . . . .	201-205
Weight and Bursting Strength of Welded Pipe . . . . .	205
Tubular Electric Line Poles . . . . .	206
Protective Coatings for Pipes . . . . .	206
Valves and Fittings . . . . .	206-217
Standard Pipe Flanges . . . . .	208-212
Forged Steel Flanges . . . . .	211
Standard Hose Couplings . . . . .	218
Wooden Stave Pipe . . . . .	218
Riveted Hydraulic Pipe . . . . .	219
Riveted Iron Pipes . . . . .	220
Spiral Riveted Pipe . . . . .	220
Weight of Steel for Riveted Pipe . . . . .	221
Bent and Coiled Pipes . . . . .	221
Flexibility of Pipe Bends . . . . .	221
Shelby Cold-drawn Steel Tubing . . . . .	222
Seamless Brass and Copper Tubes . . . . .	224, 225
Aluminum Tubing . . . . .	226
Lead and Tin-lined Lead Pipe . . . . .	226
Iron Pipe Lined with Tin, Lead, Brass, and Copper . . . . .	227
Weight of Sheet and Bar Brass . . . . .	228
of Sheet Zinc . . . . .	228
of Copper and Brass Wire and Plates . . . . .	229
of Aluminum Sheets, Bars, and Plates . . . . .	230
of Copper Rods . . . . .	230
Screw-threads, U. S. Standard . . . . .	231
Whitworth Screw-threads . . . . .	232
Limit-gages for Screw-threads . . . . .	232
Automobile Screws and Nuts . . . . .	233
International Screw-thread . . . . .	233
Acme Screw-thread . . . . .	234
Machine Screws, A. S. M. E. Standard . . . . .	234
Standard Taps . . . . .	235
Wood Screws . . . . .	236
Machine Screw Heads . . . . .	237
Set Screws and Cap Screws . . . . .	238
Weights of Rivets . . . . .	238, 239
Shearing Value of Rivets, Bearing Value of Riveted Plates . . . . .	240
Length of Rivets for Various Grips . . . . .	241
Lag Screws . . . . .	241
Weight of Bolts with Square Heads and Nuts . . . . .	242
Washers . . . . .	242, 243
Hanger Bolts . . . . .	243
Turnbuckles . . . . .	243
Track Bolts . . . . .	244
Cut Nails . . . . .	244
Material Required per Mile of Railroad Track . . . . .	245
Wire Nails . . . . .	246
Spikes . . . . .	248

	PAGE
Wires of Different Metals . . . . .	248
Steel Wire, Size, Strength, etc. . . . .	249
Piano Wire . . . . .	250
Telegraph Wire . . . . .	250-252
Plow-steel Wire . . . . .	250, 258
Galvanized Iron Wire . . . . .	250
Copper Wire, Bare and Insulated . . . . .	251, 252
Notes on Wire Rope . . . . .	253
Wire Rope Tables . . . . .	255-262
Varieties and Uses of Wire Rope . . . . .	256
Splicing of Wire Ropes . . . . .	263
Chains and Chain Cables . . . . .	264
Sizes of Fire Brick . . . . .	266
Refractoriness of American Fire-brick . . . . .	268
Slag Bricks and Slag Blocks . . . . .	268
Magnesia Bricks . . . . .	269
Fire Clay Analysis . . . . .	269
Zirconia . . . . .	270
Asbestos . . . . .	270
Standard Cross-sections of Materials, for Draftsmen . . . . .	271

### Strength of Materials.

Stress and Strain . . . . .	272
Elastic Limit . . . . .	273
Yield Point . . . . .	273
Modulus of Elasticity . . . . .	274
Resilience . . . . .	274
Elastic Limit and Ultimate Stress . . . . .	275
Repeated Stresses . . . . .	275
Repeated Shocks . . . . .	276
Stresses due to Sudden Shocks . . . . .	278
Tensile Strength . . . . .	278
Measurement of Elongation . . . . .	279
Shapes of Test Specimens . . . . .	280
Increasing Tensile Strength of Bars by Twisting . . . . .	280
Compressive Strength . . . . .	281
Columns, Pillars, or Struts . . . . .	283
Hodgkinson's Formula. Euler's Formula . . . . .	283
Gordon's Formula. Rankine's Formula . . . . .	284
Wrought-iron Columns . . . . .	285
Built Columns . . . . .	285-286
The Straight-line Formula . . . . .	285
Comparison of Column Formulæ . . . . .	286
Tests of Large Built Steel Columns . . . . .	287
Working Strains in Bridge Members . . . . .	287
Strength of Cast-iron Columns . . . . .	289
Safe Load on Cast-iron Columns . . . . .	291
Strength of Brackets on Cast-iron Columns . . . . .	292
Moment of Inertia . . . . .	293
Radius of Gyration . . . . .	293
Elements of Usual Sections . . . . .	294
Eccentric Loading of Columns . . . . .	296
Transverse Strength . . . . .	297
Formulæ for Flexure of Beams . . . . .	297
Safe Loads on Steel Beams . . . . .	298, 309
Beams of Uniform Strength . . . . .	301
Dimensions and Weights of Structural Steel Sections . . . . .	302
Allowable Tension in Steel Bars . . . . .	305
Properties of Rolled Structural Shapes . . . . .	305
"    "    Steel I-Beams . . . . .	307
"    "    Steel Wrought Plates . . . . .	308
"    "    Corrugated Plates . . . . .	310
Spacing of Steel I-Beams . . . . .	311
Properties of Steel Channels . . . . .	312
"    "    T Shapes . . . . .	313



	PAGE
Properties of Angles . . . . .	316
"    "    Z-bars . . . . .	317
Rivet Spacing for Structural Work . . . . .	321
Dimensions and Safe Load on Built Steel Columns . . . . .	323-330
Bethlehem Girder and I-beams and H-columns . . . . .	331
Torsional Strength . . . . .	334
Elastic Resistance to Torsion . . . . .	334
Combined Stresses . . . . .	335
Stress due to Temperature . . . . .	335
Strength of Flat Plates . . . . .	336
Thickness of Flat Cast-iron Plates . . . . .	336
Strength of Unstayed Flat Surfaces . . . . .	337
Unbraced Heads of Boilers . . . . .	337
Strength of Stayed Surfaces . . . . .	338
Stresses in Steel Plating under Water Pressure . . . . .	338
Spherical Shells and Domed Heads . . . . .	339
Thick Hollow Cylinders under Tension . . . . .	339
Thin Cylinders under Tension . . . . .	340
Carrying Capacity of Steel Rollers and Balls . . . . .	340
Resistance of Hollow Cylinders to Collapse . . . . .	341, 343
Formula for Corrugated Furnaces . . . . .	342
Hollow Copper Balls . . . . .	345
Holding Power of Nails, Spikes, Bolts, and Screws . . . . .	346
Cut <i>versus</i> Wire Nails . . . . .	347
Strength of Bolts . . . . .	347
Initial Strain on Bolts . . . . .	347
Strength of Chains . . . . .	348
Stand Pipes and their Design . . . . .	349
Riveted Steel Water-pipes . . . . .	351
Kirkaldy's Tests of Materials . . . . .	352-358
Cast Iron . . . . .	352
Iron Castings . . . . .	352
Iron Bars, Forgings, etc. . . . .	352
Steel Rails and Tires . . . . .	353
Spring Steel, Steel Axles, Shafts . . . . .	354
Riveted Joints, Welds . . . . .	355
Copper, Brass, Bronze, etc. . . . .	356
Wire-rope . . . . .	356
Wire . . . . .	357
Ropes, Hemp, and Cotton . . . . .	357
Belting, Canvas . . . . .	357
Stones . . . . .	357
Brick, Cement, Wood . . . . .	358
Tensile Strength of Wire . . . . .	358
Watertown Testing-machine Tests . . . . .	359
Riveted Joints . . . . .	359
Wrought-iron Bars, Compression Tests . . . . .	359
Steel Eye-bars . . . . .	360
Wrought-iron Columns . . . . .	360
Cold Drawn Steel . . . . .	361
Tests of Steel Angles . . . . .	362
Shearing Strength . . . . .	362
Relation of Shearing to Tensile Strength . . . . .	362
Strength of Iron and Steel Pipe . . . . .	363
Threading Tests of Pipe . . . . .	363
Old Tubes used as Columns . . . . .	363
Methods of Testing Hardness of Metals . . . . .	364
Holding Power of Boiler-tubes . . . . .	364
Strength of Glass . . . . .	365
Strength of Ice . . . . .	366
Strength of Timber . . . . .	366
Expansion of Timber . . . . .	367, 369
Tests of American Woods . . . . .	367
Shearing Strength of Woods . . . . .	367
Copper at High Temperatures . . . . .	368
Drying of Wood . . . . .	368
Preservation of Timber . . . . .	368

	PAGE
Copper Castings of High Conductivity.....	368
Tensile Strength of Rolled Zinc Plates.....	369
Strength of Brick, Stone, etc.....	369
"    " Lime and Cement Mortar.....	372
"    " Flagging.....	373
Tests of Portland Cement.....	373
Moduli of Elasticity of Various Materials.....	374
Factors of Safety.....	374
Properties of Cork.....	377
Vulcanized India-Rubber.....	378
Specifications for Air Hose.....	379
Nickel.....	379
Aluminum, Properties and Uses.....	380

**Alloys.**

Alloys of Copper and Tin, Bronze.....	384
Alloys of Copper and Zinc, Brass.....	386
Variation in Strength of Bronze.....	386
Copper-tin-zinc Alloys.....	387
Liquation or Separation of Metals.....	388
Alloys used in Brass Foundries.....	390
Tobin Bronze.....	392
Qualities of Miscellaneous Alloys.....	392
Copper-zinc-iron Alloys.....	393
Alloys of Copper, Tin, and Lead.....	394
Phosphor Bronze.....	394
Alloys for Casting under Pressure.....	395
Aluminum Alloys.....	396
Caution as to Strength of Alloys.....	398
Alloys of Aluminum, Silicon, and Iron.....	398
Tungsten-aluminum Alloys.....	399
The Thermit Process.....	400
Aluminum-tin Alloys.....	400
Manganese Alloys.....	401
Manganese Bronze.....	401
German Silver.....	402
Monel Metal.....	403
Copper-nickel Alloys.....	403
Alloys of Bismuth.....	404
Fusible Alloys.....	404
Bearing Metal Alloys.....	405
Bearing Metal Practice, 1907.....	407
White Metal for Engine Bearings.....	407
Alloys containing Antimony.....	407
White-metal Alloys.....	407
Babbitt Metals.....	407, 408
Type-metal.....	408
Solders.....	409

**Ropes and Cables.**

Strength of Hemp, Iron, and Steel Ropes.....	410
Rope for Hoisting or Transmission.....	411
Cordage, Technical Terms of.....	411
Splicing of Ropes.....	412
Cargo Hoisting.....	414
Working Loads for Manila Rope.....	414
Knots.....	415
Life of Hoisting and Transmission Rope.....	415
Efficiency of Rope Tackles.....	415

**Springs.**

Laminated Steel Springs.....	417
Helical Steel Springs.....	418

	PAGE
Carrying Capacity of Springs . . . . .	419
Elliptical Springs . . . . .	423
Springs to Resist Torsional Force . . . . .	423
Phosphor-bronze Springs . . . . .	424
Chromium-Vanadium Spring Steel . . . . .	424
Test of a Vanadium Steel Spring . . . . .	424

### Riveted Joints.

Fairbairn's Experiments . . . . .	424
Loss of Strength by Punching . . . . .	424
Strength of Perforated Plates . . . . .	424
Hand <i>versus</i> Hydraulic Riveting . . . . .	424
Formulæ for Pitch of Rivets . . . . .	427, 434
Proportions of Joints . . . . .	427
Efficiencies of Joints . . . . .	428
Diameter of Rivets . . . . .	429
Shearing Resistance of Rivet Iron and Steel . . . . .	430
Strength of Riveted Joints . . . . .	431
Riveting Pressures . . . . .	435
Tests of Soft Steel Rivets . . . . .	435

### Iron and Steel.

Classification of Iron and Steel . . . . .	436
Grading of Pig Iron . . . . .	437
Manufacture of Cast Iron . . . . .	437
Influence of Silicon Sulphur, Phos. and Mn on Cast Iron . . . . .	438
Microscopic Constituents . . . . .	439
Analyses of Cast Iron . . . . .	439
Specifications for Pig Iron and Castings . . . . .	441, 443
Specifications for Cast-iron Pipe . . . . .	441
Chemical Standards for Castings . . . . .	441
Strength of Cast Iron . . . . .	444, 451
Strength in Relation to Cross-section . . . . .	446, 447
"Semi-steel" . . . . .	446, 453
Shrinkage of Cast Iron . . . . .	447
White Iron Converted into Gray . . . . .	448
Mobility of Molecules of Cast Iron . . . . .	449
Expansion of Iron by Heat . . . . .	449, 465
Permanent Expansion of Cast Iron by Heating . . . . .	449
Castings from Blast Furnace Metal . . . . .	450
Effect of Cupola Melting . . . . .	450
Additions of Titanium, etc., to Cast Iron . . . . .	450, 451
Mixture of Cast Iron with Steel . . . . .	453
Bessemerized Cast Iron . . . . .	453
Bad Cast Iron . . . . .	453
Malleable Cast Iron . . . . .	454
Design of Malleable Castings . . . . .	457
Specifications of Malleable Iron . . . . .	457
Strength of Malleable Cast Iron . . . . .	458
Wrought Iron . . . . .	459
Chemistry of Wrought Iron . . . . .	460
Electrolytic Iron . . . . .	460
Influence of Rolling on Wrought Iron . . . . .	460
Specifications for Wrought Iron . . . . .	461
Stay-bolt Iron . . . . .	462
Tenacity of Iron at High Temperatures . . . . .	463
Effect of Cold on Strength of Iron . . . . .	464
Durability of Cast Iron . . . . .	465
Corrosion of Iron and Steel . . . . .	466
Corrosion of Iron and Steel Pipes . . . . .	467
Electrolytic Theory, and Prevention of Corrosion . . . . .	468
Chrome Paints, Anti-corrosive . . . . .	469
Corrosion Caused by Stray Electric Currents . . . . .	470
Electrolytic Corrosion due to Overstrain . . . . .	470

	PAGE
Preservative Coatings, Paints, etc. . . . .	471
Inoxydation Processes, Bower-Barff, etc. . . . .	472
Aluminum Coatings. . . . .	473
Galvanizing. . . . .	473
Sherardizing, Galvanizing by Cementation. . . . .	474
Lead Coatings. . . . .	474

### Steel.

Manufacture of Steel. . . . .	475
Crucible, Bessemer, and Open Hearth Steel. . . . .	475
Relation between Chemical and Physical Properties. . . . .	476
Electric Conductivity. . . . .	477
"Armco Ingot Iron". . . . .	477
Variation in Strength. . . . .	477, 478
Bending Tests of Steel. . . . .	478
Effect of Heat Treatment and of Work. . . . .	478
Hardening Soft Steel. . . . .	479
Effect of Cold Rolling. . . . .	479
Comparison of Full-sized and Small Pieces. . . . .	480
Recalescence of Steel. . . . .	480
Critical Point. . . . .	480
Metallography. . . . .	480
Burning, Overheating, and Restoring Steel. . . . .	481
Working Steel at a Blue Heat. . . . .	482
Oil Tempering and Annealing. . . . .	482
Brittleness due to Long-continued Heating. . . . .	483
Influence of Annealing upon Magnetic Capacity. . . . .	483
Treatment of Structural Steel. . . . .	483
May Carbon be Burned out of Steel? . . . . .	485
Effect of Nicking a Bar. . . . .	485
Dangerous Low Carbon Steel. . . . .	486
Specific Gravity. . . . .	486
Occasional Failures. . . . .	486
Segregation in Ingots and Plates. . . . .	487
Endurance of Steel under Repeated Stresses. . . . .	487
Welding of Steel. . . . .	488
The Thermit Welding Process. . . . .	488
Oxy-acetylene Welding and Cutting of Metals. . . . .	488
Hydraulic Forging. . . . .	488
Fluid-compressed Steel. . . . .	488
Steel Castings. . . . .	489
Crucible Steel. . . . .	490
Effect of Heat on Grain. . . . .	491
Heating and Forging. . . . .	491
Tempering Steel. . . . .	493
Kinds of Steel used for Different Purposes. . . . .	494
High-speed Tool Steel. . . . .	494
Manganese Steel. . . . .	494
Chrome Steel. . . . .	496
Aluminum Steel. . . . .	496
Tungsten Steel. . . . .	496
Nickel Steel. . . . .	497
Copper Steel. . . . .	499
Nickel-Vanadium Steel. . . . .	499
Static and Dynamic Properties of Steel. . . . .	500
Strength and Fatigue Resistance of Steels. . . . .	501
Chromium-Vanadium Steel. . . . .	502
Heat Treatment of Alloy Steels. . . . .	502, 503
Specifications for Steel. . . . .	504-511
High-strength Steel for Shipbuilding. . . . .	507
Fire-box Steel. . . . .	508
Steel Rails. . . . .	508

### MECHANICS.

Matter, Weight, Mass. . . . .	511
Force, Unit of Force. . . . .	512



	PAGE
Local Weight.....	512
Inertia.....	513
Newton's Laws of Motion.....	513
Resolution of Forces.....	513
Parallelogram of Forces.....	513
Moment of a Force.....	514
Statical Moment, Stability.....	515
Stability of a Dam.....	515
Parallel Forces.....	515
Couples.....	515
Equilibrium of Forces.....	516
Center of Gravity.....	516
Moment of Inertia.....	517
Centers of Oscillation and Percussion.....	518
Center and Radius of Gyration.....	518
The Pendulum.....	520
Conical Pendulum.....	520
Centrifugal Force.....	521
Velocity, Acceleration, Falling Bodies.....	521
Value of $g$ .....	522
Angular Velocity.....	522
Height due to Velocity.....	523
Parallelogram of Velocities.....	523
Velocity due to Falling a Given Height.....	524
Fundamental Equations in Dynamics.....	525
Force of Acceleration.....	526
Formulae for Accelerated Motion.....	527
Motion on Inclined Planes.....	527
Momentum.....	527
Work, Energy, Power.....	528
Work of Acceleration.....	529
Work of Accelerated Rotation.....	529
Force of a Blow.....	529
Impact of Bodies.....	530
Energy of Recoil of Guns.....	531
Conservation of Energy.....	531
Sources of Energy.....	531
Perpetual Motion.....	532
Efficiency of a Machine.....	532
Animal-power, Man-power.....	532
Man-wheel, Tread Mills.....	533
Work of a Horse.....	533
Horse-gin.....	534
Resistance of Vehicles.....	534

### Elements of Mechanics.

The Lever.....	535
The Bent Lever.....	536
The Moving Strut.....	536
The Toggle-joint.....	536
The Inclined Plane.....	537
The Wedge.....	537
The Screw.....	537
The Cam.....	537
Efficiency of a Screw.....	538
Efficiency of Screw Bolts.....	538
Pulleys or Blocks.....	539
Differential Pulley.....	539
Wheel and Axle.....	539
Toothed-wheel Gearing.....	539
Endless Screw, Worm Gear.....	540
Differential Windlass.....	540
Differential Screw.....	540
Efficiency of a Differential Screw.....	541

## Stresses in Framed Structures.

	PAGE
Cranes and Derricks . . . . .	541
Shear Poles and Guys . . . . .	542
King Post Truss or Bridge . . . . .	543
Queen Post Truss . . . . .	543
Burr Truss . . . . .	544
Pratt or Whipple Truss . . . . .	544
Method of Moments . . . . .	545
Howe Truss . . . . .	546
Warren Girder . . . . .	546
Roof Truss . . . . .	547
The Economical Angle . . . . .	548

## HEAT.

Thermometers and Pyrometers . . . . .	549
Centigrade and Fahrenheit degrees compared . . . . .	550
Temperature Conversion Table . . . . .	552
Copper-ball Pyrometer . . . . .	553
Thermo-electric Pyrometer . . . . .	554
Temperatures in Furnaces . . . . .	554
Seger's Fire-clay Pyrometer . . . . .	555
Wiborgh Air Pyrometer . . . . .	555
Mesuré and Nouel's Pyrometer . . . . .	556
Uehling and Steinbart Pyrometer . . . . .	557
Air-thermometer . . . . .	557
High Temperatures Judged by Color . . . . .	558
Boiling-points of Substances . . . . .	559
Melting-points . . . . .	559
Unit of Heat . . . . .	560
Mechanical Equivalent of Heat . . . . .	560
Heat of Combustion . . . . .	560
Heat Absorbed by Decomposition . . . . .	561
Specific Heat . . . . .	562
Thermal Capacity of Gases . . . . .	564
Expansion by Heat . . . . .	565
Absolute Temperature, Absolute Zero . . . . .	567
Latent Heat of Fusion . . . . .	568
Latent Heat of Evaporation . . . . .	568
Total Heat of Evaporation . . . . .	569
Evaporation and Drying . . . . .	569
Evaporation from Reservoirs . . . . .	569
Evaporation by the Multiple System . . . . .	570
Resistance to Boiling . . . . .	570
Manufacture of Salt . . . . .	570
Solubility of Salt . . . . .	571
Salt Contents of Brines . . . . .	571
Concentration of Sugar Solutions . . . . .	572
Evaporating by Exhaust Steam . . . . .	572
Drying in Vacuum . . . . .	573
Driers and Drying . . . . .	574
Design of Drying Apparatus . . . . .	576
Humidity Table . . . . .	577
Radiation of Heat . . . . .	578
Black-body Radiation . . . . .	579
Conduction and Convection of Heat . . . . .	579
Rate of External Conduction . . . . .	580
Heat Conduction of Insulating Materials . . . . .	581
Heat Resistance, Reciprocal of Heat Conductivity . . . . .	582
Steam-pipe Coverings . . . . .	584
Transmission through Plates . . . . .	587
Transmission in Condenser Tubes . . . . .	588
Transmission of Heat in Feed-water Heaters . . . . .	590
Transmission through Cast-iron Plates . . . . .	591
Heating Water by Steam Coils . . . . .	591
Transmission from Air or Gases to Water . . . . .	592

	PAGE
Transmission from Flame to Water . . . . .	593
Cooling of Air . . . . .	594
Transmission from Steam or Hot Water to Air . . . . .	595
Thermodynamics . . . . .	597
Entropy . . . . .	599
Reversed Carnot Cycle, Refrigeration . . . . .	600
Principal Equations of a Perfect Gas . . . . .	600
Construction of the Curve $PV^n = C$ . . . . .	602
Temperature-Entropy Diagram of Water and Steam . . . . .	602

**PHYSICAL PROPERTIES OF GASES.**

Expansion of Gases . . . . .	603
Boyle and Marriotte's Law . . . . .	603
Law of Charles. Avogadro's Law . . . . .	604
Saturation Point of Vapors . . . . .	604
Law of Gaseous Pressure . . . . .	604
Flow of Gases . . . . .	605
Absorption by Liquids . . . . .	605
Liquefaction of Gases, Liquid Air . . . . .	605

**AIR.**

Properties of Air . . . . .	606
Barometric Pressures . . . . .	606
Air-manometer . . . . .	607
Conversion Table for Air Pressures . . . . .	607
Pressure at Different Altitudes . . . . .	607, 609
Leveling by the Barometer and by Boiling Water . . . . .	607
To find Difference in Altitude . . . . .	608
Weight of Air at Different Pressures and Temperatures . . . . .	609
Moisture in Atmosphere . . . . .	609, 611
Humidity Table . . . . .	610
Weight of Air and Mixtures of Air and Vapor . . . . .	610, 613
Specific Heat of Air . . . . .	614

**Flow of Air.**

Flow of Air through Orifices . . . . .	615
Flow of Air in Pipes . . . . .	617
Tables of Flow of Air . . . . .	622, 623
Effects of Bends in Pipe . . . . .	624
Anemometer Measurements . . . . .	624
Equalization of Pipes . . . . .	625

**Wind.**

Force of the Wind . . . . .	626
Wind Pressure in Storms . . . . .	627
Windmills . . . . .	627
Capacity of Windmills . . . . .	629
Economy of Windmills . . . . .	630
Electric Power from Windmills . . . . .	632

**Compressed Air.**

Heating of Air by Compression . . . . .	632
Loss of Energy in Compressed Air . . . . .	632
Loss due to Heating . . . . .	633
Work of Adiabatic Compression of Air . . . . .	634
Compound Air-compression . . . . .	635



	PAGE
Mean Effective Pressures . . . . .	635, 636
Horse-power Required for Compression . . . . .	637
Compressed-air Engines . . . . .	638
Mean and Terminal Pressures . . . . .	638
Air-compression at Altitudes . . . . .	639
Popp Compressed-air System . . . . .	639
Small Compressed-air Motors . . . . .	640
Efficiency of Air-heating Stoves . . . . .	640
Efficiency of Compressed-air Transmission . . . . .	640
Efficiency of Compressed-air Engines . . . . .	640
Air-compressors . . . . .	641
Tests of Air compressors . . . . .	643
Steam Required to Compress 100 Cu. Ft. of Air . . . . .	644
Requirements of Rock-drills . . . . .	645
Compressed Air for Pumping Plants . . . . .	645
Compressed Air for Hoisting Engines . . . . .	646
Practical Results with Air Transmission . . . . .	647
Effect of Intake Temperature . . . . .	647
Compressed-air Motors with Return Circuit . . . . .	648
Intercoolers for Air-compressors . . . . .	648
Centrifugal Air-compressors . . . . .	648
High-pressure Centrifugal Fans . . . . .	649
Test of a Hydraulic Air-compressor . . . . .	650
Mekarski Compressed-air Tramways . . . . .	652
Compressed Air Working Pumps in Mines . . . . .	652
Compressed Air for Street Railways . . . . .	652

### Fans and Blowers.

Centrifugal Fans . . . . .	653
Best Proportions of Fans . . . . .	653
Pressure due to Velocity . . . . .	653
Blast Area or Capacity Area . . . . .	655
Pressure Characteristics of Fans . . . . .	655
Quantity of Air Delivered . . . . .	655
Efficiency of Fans and Positive Blowers . . . . .	657
Tables of Centrifugal Fans . . . . .	658-666
Effect of Resistance on Capacity of Fans . . . . .	664
Sirocco or Multivane Fans . . . . .	664
Methods of Testing Fans . . . . .	667
Horse-power of a Fan . . . . .	668
Pitot Tube Measurements . . . . .	669
Thomas Electric Air and Gas Meter . . . . .	669
Flow of Air through an Orifice . . . . .	670
Diameter of Blast-pipes . . . . .	670
Centrifugal Ventilators for Mines . . . . .	672
Experiments on Mine Ventilators . . . . .	673
Disk Fans . . . . .	675
Efficiency of Disk Fans . . . . .	676
Positive Rotary Blowers . . . . .	677
Steam-jet Blowers and Exhausters . . . . .	679
Blowing Engines . . . . .	680

### HEATING AND VENTILATION.

Ventilation . . . . .	681
Quantity of Air Discharged through a Ventilating Duct . . . . .	683
Heating and Ventilating of Large Buildings . . . . .	684
Comfortable Temperatures and Humidities . . . . .	685
Carbon Dioxide Allowable in Factories . . . . .	685
Standards of Ventilation . . . . .	686
Air Washing . . . . .	687
Contamination of Air . . . . .	687
Standards for Calculating Heating Problems . . . . .	687

	PAGE
Heating Value of Coal . . . . .	687
Heat Transmission through Walls, etc . . . . .	688
Allowance for Exposure and Leakage . . . . .	689
Heating by Hot-air Furnaces . . . . .	690
Carrying Capacity of Air-pipes . . . . .	691
Volume of Air at Different Temperatures . . . . .	692
Sizes of Pipes Used in Furnace Heating . . . . .	692
Furnace Heating with Forced Air Supply . . . . .	693
Rated Capacity of Boilers for House Heating . . . . .	693
Capacity of Grate-surface . . . . .	694
Steam Heating, Rating of Boilers . . . . .	694
Testing Cast-iron Heating Boilers . . . . .	696
Proportioning House Heating Boilers . . . . .	696
Coefficient of Transmission in Direct Radiation . . . . .	697
Heat Transmitted in Indirect Radiation . . . . .	698
Short Rules for Computing Radiating Surface . . . . .	698
Carrying Capacity of Steam Pipes in Low Pressure Heating . . . . .	698
Proportioning Pipes to Radiating Surface . . . . .	700
Sizes of Pipes in Steam Heating Plants . . . . .	701
Resistance of Fittings . . . . .	701
Removal of Air, Vacuum Systems . . . . .	702
Overhead Steam-pipes . . . . .	702
Steam-consumption in Car-heating . . . . .	702
Heating a Greenhouse by Steam . . . . .	702
Heating a Greenhouse by Hot Water . . . . .	703
Hot-water Heating . . . . .	703
Velocity of Flow in Hot-water Heating . . . . .	703
Sizes of Pipe for Hot-water Heating . . . . .	704
Sizes of Flow and Return Pipes . . . . .	705
Heating by Hot-water, with Forced Circulation . . . . .	707
Corrosion of Pipe in Hot-water Heating . . . . .	708
Blower System of Heating and Ventilating . . . . .	708
Advantages and Disadvantages of the Plenum System . . . . .	708
Heat Radiated from Coils in the Blower System . . . . .	708
Test of Cast-iron Heaters for Hot-blast Work . . . . .	709
Factory Heating by the Fan System . . . . .	710
Artificial Cooling of Air . . . . .	710
Capacities of Fans for Hot-blast Heating . . . . .	711
Relative Efficiency of Fans and Heated Chimneys . . . . .	712
Heating a Building to 70° F. . . . .	712
Heating by Electricity . . . . .	713
Mine-ventilation . . . . .	714
Friction of Air in Underground Passages . . . . .	714
Equivalent Orifices . . . . .	715

**WATER.**

Expansion of Water . . . . .	716
Weight of Water at Different Temperatures . . . . .	716, 717
Pressure of Water due to its Weight . . . . .	718,
Head Corresponding to Pressures . . . . .	718
Buoyancy . . . . .	719
Boiling-point . . . . .	719
Freezing-point . . . . .	719
Sea-water . . . . .	719
Ice and Snow . . . . .	720
Specific Heat of Water . . . . .	720
Compressibility of Water . . . . .	720
Impurities of Water . . . . .	720
Causes of Incrustation . . . . .	721
Means for Preventing Incrustation . . . . .	721
Analyses of Boiler-scale . . . . .	722
Hardness of Water . . . . .	723
Purifying Feed-water . . . . .	723
Softening Hard Water . . . . .	724

<b>Hydraulics. Flow of Water.</b>		PAGE
Formulae for Discharge through Orifices and Weirs . . . . .		726
Flow of Water from Orifices . . . . .		727
Flow in Open and Closed Channels . . . . .		728
General Formulae for Flow . . . . .		728
Chezy's Formula . . . . .		728
Values of the Coefficient $c$ . . . . .	728,	732
Table, Fall in Feet per mile, etc. . . . .		729
Values of $\sqrt{r}$ for Circular Pipes . . . . .		730
Kutter's Formula . . . . .		730
D'Arcy's Formula . . . . .		732
Values of $a\sqrt{r}$ for Chezy's Formula . . . . .		733
Values of the Coefficient of Friction . . . . .		734
Loss of Head . . . . .		735
Resistance at the Inlet of a pipe . . . . .		735
Exponential Formulae, Williams' and Hazen's Tables . . . . .		736
Short Formulae . . . . .		737
Flow of Water in a 20-inch Pipe . . . . .		737
Coefficients for Reducing H. and W. to Chezy's Formula . . . . .		737
Tables of Flow of Water in Circular Pipes . . . . .	738-	743
Flow of Water in Riveted Pipes . . . . .		743
Long Pipe Lines . . . . .		743
Flow of Water in House-service Pipes . . . . .		744
Friction Loss in Clean Cast-iron Pipe . . . . .		745
Approximate Hydraulic Formulae . . . . .		746
Compound Pipes, and Pipes with Branches . . . . .		746
Rifled Pipes for Conveying Oils . . . . .		746
Effect of Bend and Curves . . . . .		747
Loss of Pressure Caused by Valves, etc. . . . .	747,	748
Hydraulic Grade-line . . . . .		748
Air-bound Pipes . . . . .		748
Water Hammer . . . . .		749
Vertical Jets . . . . .		749
Water Delivered through Meters . . . . .		749
Price Charged for Water in Cities . . . . .		749
Fire Streams . . . . .		749
Hydrant Pressures Required with Different Lengths and Sizes of Hose . . . . .		750
Pump Inspection Table . . . . .		751
Pipe Sizes for Ordinary Fire Streams . . . . .		752
Friction Losses in Hose . . . . .		752
Rated Capacity of Steam Fire-engines . . . . .		752
Flow of Water through Nozzles . . . . .		753
The Siphon . . . . .		754
Velocity of Water in Open Channels . . . . .		755
Mean Surface and Bottom Velocities . . . . .		755
Safe Bottom and Mean Velocities . . . . .		755
Resistance of Soil to Erosion . . . . .		755
Abrading and Transporting Power of Water . . . . .		755
Frictional Resistance of Surfaces Moved in Water . . . . .		756
Grade of Sewers . . . . .		757
Measurement of Flowing Water . . . . .		757
Piezometer . . . . .		757
Pitot Tube Gauge . . . . .		757
Maximum and Mean Velocities in Pipes . . . . .		758
The Venturi Meter . . . . .		758
Measurement of Discharge by Means of Nozzles . . . . .		759
The Lea V-notch Recording Meter . . . . .		759
Flow through Rectangular Orifices . . . . .		760
Measurement of an Open Stream . . . . .		760
Miners' Inch Measurements . . . . .		761
Flow of Water over Weirs . . . . .		762
Francis's Formula for Weirs . . . . .		762
Weir Table . . . . .		763
Bazin's Experiments . . . . .		763
The Cippoletti, or Trapezoidal Weir . . . . .		764
The Triangular Weir . . . . .		764

**WATER-POWER.**

	PAGE
Power of a Fall of Water . . . . .	765
Horse-power of a Running Stream . . . . .	765
Current Motors . . . . .	765
Bernouilli's Theorem . . . . .	765
Maximum Efficiency of a Long Conduit . . . . .	766
Mill-power . . . . .	766
Value of Water-power . . . . .	766

**Water Wheels. Turbine Wheels.**

Water Wheels . . . . .	768
Proportions of Turbines . . . . .	768
Tests of Turbines . . . . .	773
Dimensions of Turbines . . . . .	774
Rating and Efficiency of Turbines . . . . .	774
Rating Table for Turbines . . . . .	777
Turbines of 13,500 H. P. each . . . . .	778
The Fall-increaser for Turbines . . . . .	778
Tangential or Impulse Water Wheel . . . . .	779
The Pelton Water Wheel . . . . .	779
Considerations in the Choice of a Tangential Wheel . . . . .	780
Control of Tangential Water Wheels . . . . .	781
Tangential Water-wheel Table . . . . .	782
Amount of Water Required to Develop a Given Horse-Power . . . . .	784
Efficiency of the Doble Nozzle . . . . .	785
Water Plants Operating under High Pressure . . . . .	785
Formulæ for Calculating the Power of Jet Water Wheels . . . . .	785

**The Power of Ocean Waves.**

Energy of Deep Sea Waves . . . . .	786
Utilization of Tidal Power . . . . .	787

**PUMPS AND PUMPING ENGINES.**

Theoretical Capacity of a Pump . . . . .	788
Depth of Suction . . . . .	788
The Deane Pump . . . . .	789
Sizes of Direct-acting Pumps . . . . .	789, 791
Amount of Water Raised by a Single-acting Lift-pump . . . . .	790
Proportioning the Steam-cylinder of a Direct-acting Pump . . . . .	790
Speed of Water through Pipes and Pump-passages . . . . .	790
Efficiency of Small Pumps . . . . .	790
The Worthington Duplex Pump . . . . .	791
Speed of Piston . . . . .	791-792
Speed of Water through Valves . . . . .	792
Underwriters' Pumps, Standard Sizes . . . . .	792
Boiler-feed Pumps . . . . .	792
Pump Valves . . . . .	793
The Worthington High-duty Pumping Engine . . . . .	793
The d'Auria Pumping Engine . . . . .	793
A 72,000,000-Gallon Pumping Engine . . . . .	793
The Screw Pumping Engine . . . . .	794
Finance of Pumping Engine Economy . . . . .	794
Cost of Pumping 1000 Gallons per Minute . . . . .	795
Centrifugal Pumps . . . . .	796
Design of a Four-stage Turbine Pump . . . . .	797
Relation of Peripheral Speed to Head . . . . .	797
Tests of De Laval Centrifugal Pump . . . . .	798
A High-duty Centrifugal Pump . . . . .	801
Rotary Pumps . . . . .	801
Tests of Centrifugal and Rotary Pumps . . . . .	802
Duty Trials of Pumping Engines . . . . .	802



	PAGE
Leakage Tests of Pumps.....	803
Notable High-duty Pump Records.....	805
Vacuum Pumps.....	806
The Pulsometer.....	806
The Jet Pump.....	807
The Injector.....	807
Pumping by Compressed Air.....	808
Gas-engine Pumps; The Humphrey Gas Pump.....	808
Air-lift Pump.....	808
Air-lifts for Deep Oil-wells.....	809
The Hydraulic Ram.....	810
Quantity of Water Delivered by the Hydraulic Ram.....	810

**Hydraulic Pressure Transmission.**

Energy of Water under Pressure.....	812
Efficiency of Apparatus.....	812
Hydraulic Presses.....	813
Hydraulic Power in London.....	814
Hydraulic Riveting Machines.....	814
Hydraulic Forging.....	814
Hydraulic Engine.....	815

**FUEL.**

Theory of Combustion.....	816
Analyses of the Gases of Combustion.....	817
Temperature of the Fire.....	818
Classification of Solid Fuels.....	818
Classification of Coals.....	819
Analyses of Coals.....	820
Caking and Non-Caking Coals.....	820
Cannel Coals.....	821
Rhode Island Graphitic Anthracite.....	821
Analysis and Heating Value of Coals.....	821-828
Approximate Heating Values.....	822
Lord and Haas's Tests.....	823
Sizes of Anthracite Coal.....	823
Space occupied by Anthracite.....	823
Bernice Basin, Pa., Coal.....	824
Connellsville Coal and Coke.....	824
Bituminous Coals of the Western States.....	824
Analysis of Foreign Coals.....	825
Sampling Coal for Analyses.....	825
Relative Value of Steam Coals.....	826
Calorimetric Tests of Coals.....	826
Classified Lists of Coals.....	828-830
Purchase of Coal Under Specifications.....	830
Weathering of Coal.....	830
Pressed Fuel.....	831
Spontaneous Combustion of Coal.....	832
Coke.....	832
Experiments in Coking.....	833
Coal Washing.....	833
Recovery of By-products in Coke Manufacture.....	833
Generation of Steam from the Waste Heat and Gases from Coke-ovens.....	834
Products of the Distillation of Coal.....	834
Wood as Fuel.....	835
Heating Value of Wood.....	835
Composition of Wood.....	835
Charcoal.....	836
Yield of Charcoal from a Cord of Wood.....	836
Consumption of Charcoal in Blast Furnaces.....	837

	PAGE
Absorption of Water and of Gases by Charcoal.....	837
Miscellaneous Solid Fuels.....	837
Dust-fuel—Dust Explosions.....	837
Peat or Turf.....	838
Sawdust as Fuel.....	838
Wet Tan-bark as Fuel.....	838
Straw as Fuel.....	839
Bagasse as Fuel in Sugar Manufacture.....	839

### Liquid Fuel.

Products of Distillation of Petroleum.....	840
Lima Petroleum.....	840
Value of Petroleum as Fuel.....	840
Fuel Oil Burners.....	842
Specifications for Purchase of Fuel Oil.....	843
Alcohol as Fuel.....	843
Specific Gravity of Ethyl Alcohol.....	844
Vapor Pressures of Saturation of Alcohol and other Liquids....	844

### Fuel Gas.

Carbon Gas.....	845
Anthracite Gas.....	845
Bituminous Gas.....	846
Water Gas.....	846
Natural Gas in Ohio and Indiana.....	847
Natural Gas as a Fuel for Boilers.....	847
Producer-gas from One Ton of Coal.....	848
Combustion of Producer-gas.....	849
Proportions of Gas Producers and Scrubbers.....	849
Gas Producer Practice.....	851
Capacity of Producers.....	851
High Temperature Required for Production of CO.....	852
The Mond Gas Producer.....	852
Relative Efficiency of Different Coals in Gas-engine Tests.....	853
Use of Steam in Producers and Boiler Furnaces.....	854
Gas Analyses by Volume and by Weight.....	854
Gas Fuel for Small Furnaces.....	854
Blast-furnace Gas.....	855

### Acetylene and Calcium Carbide.

Acetylene.....	855
Calcium Carbide.....	856
Acetylene Generators and Burners.....	857
The Acetylene Blowpipe.....	857
Ignition Temperature of Gases.....	858

### Illuminating Gas.

Coal-gas.....	858
Water-gas.....	858
Analyses of Water-gas and Coal-gas.....	860
Calorific Equivalents of Constituents.....	860
Efficiency of a Water-gas Plant.....	861
Space Required for a Water-gas Plant.....	862
Fuel-value of Illuminating Gas.....	863
Flow of Gas in Pipes.....	864
Services for Lamps.....	864
Factors for Reducing Volumes of Gas.....	865

### STEAM.

Temperature and Pressure.....	867
Total Heat.....	867
Latent Heat of Steam.....	867

	PAGE
Specific Heat of Saturated Steam.....	867
The Mechanical Equivalent of Heat.....	868
Pressure of Saturated Steam.....	868
Volume of Saturated Steam.....	868
Specific Heat of Superheated Steam.....	869
Specific Density of Gaseous Steam.....	870
Table of the Properties of Saturated Steam.....	871-874
Table of the Properties of Superheated Steam.....	874, 875

### Flow of Steam.

Flow of Steam through a Nozzle.....	876
Napier's Approximate Rule.....	876
Flow of Steam in Pipes.....	877
Flow of Steam in Long Pipes, Ledoux's Formula.....	877
Table of Flow of Steam in Pipes.....	878
Carrying Capacity of Extra Heavy Steam Pipes.....	879
Resistance to Flow by Bends, Valves, etc.....	879
Sizes of Steam-pipes for Stationary Engines.....	879
Sizes of Steam-pipes for Marine Engines.....	880
Proportioning Pipes for Minimum Loss by Radiation and Friction	880
Available Maximum Efficiency of Expanded Steam.....	881

### Steam-pipes.

Bursting-tests of Copper Steam-pipes.....	882
Failure of a Copper Steam-pipe.....	882
Wire-wound Steam-pipes.....	882
Materials for Pipes and Valves for Superheated Steam.....	882
Riveted Steel Steam-pipes.....	883
Valves in Steam-pipes.....	883
The Steam Loop.....	883
Loss from an Uncovered Steam-pipe.....	884
Condensation in an Underground Pipe Line.....	884
Steam Receivers in Pipe Lines.....	884
Equation of Pipes.....	884
Identification of Power House Piping by Colors.....	885

### THE STEAM-BOILER.

The Horse-power of a Steam-boiler.....	885
Measures for Comparing the Duty of Boilers.....	886
Unit of Evaporation.....	886
Steam-boiler Proportions.....	887
Heating-surface.....	887
Horse-power, Builders' Rating.....	888
Grate-surface.....	888
Areas of Flues.....	889
Air-passages Through Grate-bars.....	889
Performance of Boilers.....	889
Conditions which Secure Economy.....	890
Air Leakage in Boiler Settings.....	891
Efficiency of a Boiler.....	891
Autographic CO <sub>2</sub> Recorders.....	891
Relation of Efficiency to Rate of Driving, Air Supply, etc.....	893
Effect of Quality of Coal upon Efficiency.....	895
Effect of Imperfect Combustions and Excess Air Supply.....	896
Theoretical Efficiency with Pittsburgh Coal.....	896
The Straight Line Formula for Efficiency.....	896
High Rates of Evaporation.....	898
Boilers Using Waste Gases.....	898
Maximum Efficiencies at Different Rates of Driving.....	898
Rules for Conducting Boiler Tests.....	899
Heat Balance in Boiler Tests.....	907
Factors of Evaporation.....	908



<b>Strength of Steam-bollers.</b>		PAGE
Rules for Construction . . . . .		908
Shell-plate Formulæ . . . . .		913
Efficiency of Riveted Joints . . . . .		914
Loads Allowed on Stays . . . . .		916
Holding Power of Boiler Tubes . . . . .		916
Safe-working Pressures . . . . .		918
 <b>Boiler Attachments, Furnaces, etc.</b> 		
Fusible Plugs . . . . .		918
Steam Domes . . . . .		918
Mechanical Stokers . . . . .		918
The Hawley Down-draught Furnace . . . . .		919
Under-feed Stokers . . . . .		919
Smoke Prevention . . . . .		920
Burning Illinois Coal without Smoke . . . . .		921
Conditions of Smoke Prevention . . . . .		922
Forced Combustion . . . . .		923
<b>Fuel Economizers</b> . . . . .		924
<b>Thermal Storage</b> . . . . .		927
<b>Incrustation and Corrosion</b> . . . . .		927
Boiler-scale Compounds . . . . .		929
Removal of Hard Scale . . . . .		930
Corrosion in Marine Boilers . . . . .		930
Use of Zinc . . . . .		931
Effect of Deposit on Flues . . . . .		931
Dangerous Boilers . . . . .		932
 <b>Safety-valves.</b> 		
Rules for Area of Safety-valves . . . . .		932
Spring-loaded Safety-valves . . . . .		933
Safety Valves for Locomotives . . . . .		935
 <b>The Injector.</b> 		
Equation of the Injector . . . . .		936
Performance of Injectors . . . . .		937
<b>Boiler-feeding Pumps</b> . . . . .		937
 <b>Feed-water Heaters.</b> 		
Percentage of Saving Due to Use of Heaters . . . . .		938
Strains Caused by Cold Feed-water . . . . .		939
Calculation of Surface of Heaters and Condensers . . . . .		939
Open vs. Closed Feed-water Heaters . . . . .		940
 <b>Steam Separators.</b> 		
Efficiency of Steam Separators . . . . .		941
 <b>Determination of Moisture in Steam.</b> 		
Steam Calorimeters . . . . .		942
Coil Calorimeter . . . . .		942
Throttling Calorimeters . . . . .		943
Separating Calorimeters . . . . .		943
Identification of Dry Steam . . . . .		944
Usual Amount of Moisture in Steam . . . . .		944
 <b>Chimneys.</b> 		
Chimney Draught Theory . . . . .		944
Force of Intensity of Draught . . . . .		945
Rate of Combustion Due to Height of Chimney . . . . .		947

	PAGE
High Chimneys not Necessary .....	948
Height of Chimneys Required for Different Fuels.....	948
Protection of Chimney from Lightning.....	949
Table of Size of Chimneys.....	950
Velocity of Gas in Chimneys.....	951
Size of Chimneys for Oil Fuel.....	951
Chimneys with Forced Draught.....	952
Largest Chimney in the World.....	952
Some Tall Brick Chimneys.....	953, 954
Stability of Chimneys.....	954
Steel Chimneys.....	956
Reinforced Concrete Chimneys.....	958
Sheet-iron Chimneys.....	958

### THE STEAM ENGINE.

Expansion of Steam.....	959
Mean and Terminal Absolute Pressures.....	960
Calculation of Mean Effective Pressure.....	961
Mechanical Energy of Steam Expanded Adiabatically.....	963
Measures for Comparing the Duty of Engines.....	963
Efficiency, Thermal Units per Minute.....	964
Real Ratio of Expansion.....	965
Effect of Compression.....	965
Clearance in Low- and High-speed Engines.....	966
Cylinder-condensation.....	966
Water-consumption of Automatic Cut-off Engines.....	967
Experiments on Cylinder-condensation.....	967
Indicator Diagrams.....	968
Errors of Indicators.....	969
Pendulum Indicator Rig.....	969
The Manograph.....	969
The Lea Continuous Recorder.....	970
Indicated Horse-power.....	970
Rules for Estimating Horse-power.....	970
Horse-power Constants.....	971
Table of Engine Constants.....	972
To Draw Clearance on Indicator-diagram.....	974
To Draw Hyperbola Curve on Indicator-diagram.....	974
Theoretical Water Consumption.....	975
Leakage of Steam.....	976

### Compound Engines.

Advantages of Compounding.....	976
Woolf and Receiver Types of Engines.....	977
Combined Diagrams.....	979
Proportions of Cylinders in Compound Engines.....	980
Receiver Space.....	980
Formula for Calculating Work of Steam.....	981
Calculation of Diameters of Cylinders.....	982
Triple-expansion Engines.....	983
Proportions of Cylinders.....	983
Formulae for Proportioning Cylinders.....	983
Types of Three-stage Expansion Engines.....	985
Sequence of Cranks.....	986
Velocity of Steam through Passages.....	986
A Double-tandem Triple-expansion Engine.....	986
Quadruple-expansion Engines.....	986

### Steam-engine Economy.

Economic Performance of Steam-engines.....	987
Feed-water Consumption of Different Types.....	987
Sizes and Calculated Performances of Vertical High-speed Engine.....	988

	PAGE
The Willans Law, Steam Consumption at Different Loads . . . . .	991
Relative Economy of Engines under Variable Loads . . . . .	992
Steam Consumption of Various Sizes . . . . .	992
Steam Consumption in Small Engines . . . . .	993
Steam Consumption at Various Speeds . . . . .	993
Capacity and Economy of Steam Fire Engines . . . . .	993
Economy Tests of High-speed Engines . . . . .	994
Limitation of Engine Speed . . . . .	995
British High-speed Engines . . . . .	995
Advantage of High Initial and Low-back Pressure . . . . .	996
Comparison of Compound and Single-cylinder Engines . . . . .	997
Two-cylinder and Three-cylinder Engines . . . . .	997
Steam Consumption of Engines with Superheated Steam . . . . .	998
Steam Consumption of Different Types of Engine . . . . .	999
The Lentz Compound Engine . . . . .	999
Efficiency of Non-condensing Compound Engines . . . . .	1000
Economy of Engines under Varying Loads . . . . .	1000
Effect of Water in Steam on Efficiency . . . . .	1001
Influence of Vacuum and Superheat on Steam Consumption . . . . .	1001
Practical Application of Superheated Steam . . . . .	1002
Performance of a Quadruple Engine . . . . .	1003
Influence of the Steam-jacket . . . . .	1004
Best Economy of the Piston Steam Engine . . . . .	1005
Highest Economy of Pumping-engines . . . . .	1006
Sulphur-dioxide Addendum to Steam-engine . . . . .	1007
Standard Dimensions of Direct-connected Generator Sets . . . . .	1007
Dimensions of Parts of Large Engines . . . . .	1007
Large Rolling-mill Engines . . . . .	1008
Counterbalancing Engines . . . . .	1008
Preventing Vibrations of Engines . . . . .	1008
Foundations Embedded in Air . . . . .	1009
Most Economical Point of Cut-off . . . . .	1009
Type of Engine used when Exhaust-steam is used for Heating . . . . .	1009
Cost of Steam-power . . . . .	1009
Cost of Coal for Steam-power . . . . .	1010
Power-plant Economics . . . . .	1011
Analysis of Operating Costs of Power-plants . . . . .	1013
Economy of Combination of Gas Engines and Turbines . . . . .	1014
Storing Steam Heat in Hot Water . . . . .	1014
<b>Utilizing the Sun's Heat as a Source of Power . . . . .</b>	<b>1015</b>
<b>Rules for Conducting Steam-engine Tests . . . . .</b>	<b>1015</b>

### Dimensions of Parts of Engines.

Cylinder . . . . .	1021
Clearance of Piston . . . . .	1021
Thickness of Cylinder . . . . .	1021
Cylinder Heads . . . . .	1022
Cylinder-head Bolts . . . . .	1022
The Piston . . . . .	1023
Piston Packing-rings . . . . .	1023
Fit of Piston-rod . . . . .	1024
Diameter of Piston-rods . . . . .	1024
Piston-rod Guides . . . . .	1024
The Connecting-rod . . . . .	1025
Connecting-rod Ends . . . . .	1026
Tapered Connecting-rods . . . . .	1026
The Crank-pin . . . . .	1027
Crosshead-pin or Wrist-pin . . . . .	1029
The Crank-arm . . . . .	1029
The Shaft, Twisting Resistance . . . . .	1030
Resistance to Bending . . . . .	1032
Equivalent Twisting Moment . . . . .	1032
Fly-wheel Shafts . . . . .	1033
Length of Shaft-bearings . . . . .	1034
Crank-shafts with Center-crank and Double-crank Arms . . . . .	1036

	PAGE
Crank-shaft with two Cranks Coupled at 90°.....	1037
Crank-shaft with three Cranks at 120°.....	1038
Valve-stem or Valve-rod.....	1038
The Eccentric.....	1039
The Eccentric-rod.....	1039
Reversing-gear.....	1039
Current Practice in Engine Proportions, 1897.....	1039
Current Practice in Steam-engine Design, 1909.....	1040
Shafts and Bearings of Engines.....	1042
Calculating the Dimensions of Bearings.....	1042
Engine-frames or Bed-plates.....	1044

### Fly-wheels.

Weight of Fly-wheels.....	1044
Weight of Fly-wheels for Alternating-current Units.....	1047
Centrifugal Force in Fly-wheels.....	1047
Diameters for Various Speeds.....	1048
Strains in the Rims.....	1049
Arms of Fly-wheels and Pulleys.....	1050
Thickness of Rims.....	1050
A Wooden Rim Fly-wheel.....	1051
Wire-wound Fly-wheels.....	1052

### The Slide-Valve.

Definitions, Lap, Lead, etc.....	1052
Sweet's Valve-diagram.....	1054
The Zeuner Valve-diagram.....	1054
Port Opening, Lead, and Inside Lead.....	1057
Crank Angles for Connecting-rods of Different Lengths.....	1058
Ratio of Lap and of Port-opening to Valve-travel.....	1058
Relative Motions of Crosshead and Crank.....	1060
Periods of Admission or Cut-off for Various Laps and Travels..	1060
Piston-valves.....	1061
Setting the Valves of an Engine.....	1061
To put an Engine on its Center.....	1061
Link-motion.....	1062
The Walschaerts Valve-gear.....	1064

### Governors.

Pendulum or Fly-ball Governors.....	1065
To Change the Speed of an Engine.....	1066
Fly-wheel or Shaft Governors.....	1066
The Rites Inertia Governor.....	1066
Calculation of Springs for Shaft-governors.....	1066

### Condensers, Air-pumps, Circulating-pumps, etc.

The Jet Condenser.....	1068
Quantity of Cooling Water.....	1068
Ejector Condensers.....	1069
The Barometric Condensers.....	1069
The Surface Condenser.....	1069
Coefficient of Heat Transference in Condensers.....	1070
The Power Used for Condensing Apparatus.....	1071
Vacuum, Inches of Mercury and Absolute Pressure.....	1071
Temperatures, Pressures and Volumes of Saturated Air.....	1072
Condenser Tubes.....	1072
Tube-plates.....	1073
Spacing of Tubes.....	1073
Air-pump.....	1073
Area through Valve-seats.....	1073
Work done by an Air-pump.....	1074



	PAGE
Most Economical Vacuum for Turbines.....	1075
Circulating-pump.....	1075
The Leblanc Condenser.....	1076
Feed-pumps for Marine Engines.....	1076
An Evaporative Surface Condenser.....	1076
Continuous Use of Condensing Water.....	1076
Increase of Power by Condensers.....	1077
Advantage of High Vacuum in Reciprocating Engines.....	1078
The Choice of a Condenser.....	1078
Cooling Towers.....	1079
Calculation of Air Supply for Cooling Towers.....	1080
Tests of a Cooling Tower and Condenser.....	1080
Water Evaporated in a Cooling Tower.....	1080
Weight of Water Vapor mixed with One Pound of Air.....	1081
Evaporators and Distillers.....	1082

### Rotary Steam Engines—Steam Turbines.

Rotary Steam Engines.....	1082
Impulse and Reaction Turbines.....	1082
The DeLaval Turbine.....	1082
The Zolley or Rateau Turbine.....	1083
The Parsons Turbine.....	1083
The Westinghouse Double-flow Turbine.....	1083
Mechanical Theory of the Steam Turbine.....	1084
Heat Theory of the Steam Turbine.....	1084
Velocity of Steam in Nozzles.....	1085
Speed of the Blades.....	1086
Comparison of Impulse and Reaction Turbines.....	1087
Loss due to Windage.....	1087
Efficiency of the Machine.....	1087
Steam Consumption of Turbines.....	1088
Effect of Vacuum on Steam Turbines.....	1088
Tests of Turbines.....	1088
Efficiency of the Rankine Cycle.....	1089
Factors for Reduction to Equivalent Efficiency.....	1090
Effect of Pressure, Vacuum and Superheat.....	1090
Steam and Heat Consumption of the Ideal Engine.....	1091
Westinghouse Turbines at 74th St. Station, New York.....	1092
A Steam Turbine Guarantee.....	1092
Efficiency of a 5000-K.W. Steam Turbine Generator.....	1092
Comparison of Large Turbines and Reciprocating Engines.....	1092
Steam Consumption of Small Steam Turbines.....	1093
Low-pressure Steam Turbines.....	1093
Tests of a 15,000-K.W. Steam-engine Turbine Unit.....	1095
Reduction Gear for Steam Turbines.....	1095

### Hot-air Engines.

Hot-air or Caloric Engines.....	1095
Test of a Hot-air Engine.....	1095

### Internal Combustion Engines.

Four-cycle and Two-cycle Gas-engines.....	1096
Temperatures and Pressures Developed.....	1096
Calculation of the Power of Gas-engines.....	1097
Pressures and Temperatures at End of Compression.....	1098
Pressures and Temperature at Release.....	1099
“ “ “ after Combustion.....	1099
Mean Effective Pressures.....	1099
Sizes of Large Gas-engines.....	1100
Engine Constants for Gas-engines.....	1101
Rated Capacity of Automobile Engines.....	1101
Estimate of the Horse-power of a Gas-engine.....	1101

	PAGE
Oil and Gasoline Engines.....	1101
The Diesel Oil Engine.....	1102
The De La Vergne Oil Engine.....	1102
Alcohol Engines.....	1102
Ignition.....	1102
Timing.....	1103
Governing.....	1103
Gas and Oil Engine Troubles.....	1103
Conditions of Maximum Efficiency.....	1103
Heat Losses in the Gas-engine.....	1104
Economical Performance of Gas-engines.....	1104
Utilization of Waste Heat from Gas-engines.....	1105
Rules for Conducting Tests of Gas and Oil Engines.....	1105

### LOCOMOTIVES.

Resistance of Trains.....	1108
Resistance of Electric Railway Cars and Trains.....	1110
Efficiency of the Mechanism of a Locomotive.....	1111
Adhesion.....	1111
Tractive Force.....	1111
Size of Locomotive Cylinders.....	1112
Horse-power of a Locomotive.....	1113
Size of Locomotive Boilers.....	1113
Wootten's Locomotive.....	1114
Grate-surface, Smokestacks, and Exhaust-nozzles.....	1115
Fire-brick Arches.....	1115
Economy of High Pressures.....	1116
Leading American Types.....	1116
Classification of Locomotives.....	1116
Steam Distribution for High Speed.....	1117
Formulæ for Curves.....	1117
Speed of Railway Trains.....	1118
Performance of a High-speed Locomotive.....	1118
Fuel Efficiency of American Locomotives.....	1119
Locomotive Link-motion.....	1119
Dimensions of Some American Locomotives.....	1120
The Mallet Compound Locomotive.....	1120
Indicated Water Consumption.....	1122
Indicator Tests of a Locomotive at High-speed.....	1122
Locomotive Testing Apparatus.....	1123
Weights and Prices of Locomotives.....	1124
Waste of Fuel in Locomotives.....	1125
Advantages of Compounding.....	1125
Depreciation of Locomotives.....	1125
Average Train Loads.....	1125
Tractive Force of Locomotives, 1893 and 1905.....	1125
Superheating in Locomotives.....	1126
Counterbalancing Locomotives.....	1126
Narrow-gauge Railways.....	1127
Petroleum-burning Locomotives.....	1127
Fireless Locomotives.....	1127
Self-propelled Railway Cars.....	1127
Compressed-air Locomotives.....	1128
Air Locomotives with Compound Cylinders.....	1129

### SHAFTING.

Diameters to Resist Torsional Strain.....	1130
Deflection of Shafting.....	1131
Horse-power Transmitted by Shafting.....	1132
Flange Couplings.....	1133
Effect of Cold Rolling.....	1133
Hollow Shafts.....	1133
Sizes of Collars for Shafting.....	1133
Table for Laying Out Shafting.....	1134



**PULLEYS.**

	PAGE
Proportions of Pulleys.....	1135
Convexity of Pulleys.....	1136
Cone or Step Pulleys.....	1136
Method of Determining Diameters of Cone Pulleys.....	1136
Speeds of Shafts with Cone Pulleys.....	1137
Speeds in Geometrical Progression.....	1138

**BELTING.**

Theory of Belts and Bands.....	1138
Centrifugal Tension.....	1139
Belting Practice, Formulæ for Belting.....	1139
Horse-power of a Belt one inch wide.....	1140
A. F. Nagle's Formula.....	1141
Width of Belt for Given Horse-power.....	1141
Belt Factors.....	1142
Taylor's Rules for Belting.....	1143
Barth's Studies on Belting.....	1146
Notes on Belting.....	1146
Lacing of Belts.....	1147
Setting a Belt on Quarter-twist.....	1147
To Find the Length of Belt.....	1148
To Find the Angle of the Arc of Contact.....	1148
To Find the Length of Belt when Closely Rolled.....	1148
To Find the Approximate Weight of Belts.....	1148
Relations of the Size and Speeds of Driving and Driven Pulleys.....	1148
Evils of Tight Belts.....	1149
Sag of Belts.....	1149
Arrangement of Belts and Pulleys.....	1149
Care of Belts.....	1150
Strength of Belting.....	1150
Adhesion, Independent of Diameter.....	1151
Endless Belts.....	1151
Belt Data.....	1151
U. S. Navy Specifications for Leather Belting.....	1151
Belt Dressings.....	1151
Cement for Cloth or Leather.....	1152
Rubber Belting.....	1152
Steel Belts.....	1152

**Chain Drives.**

Roller Chain and Sprocket Drives.....	1153
Belting <i>versus</i> Chain Drives.....	1155
Data used in Design of Chain Drives.....	1156
Comparison of Rope and Chain Drives.....	1157

**GEARING.**

Pitch, Pitch-circle, etc.....	1157
Diametral and Circular Pitch.....	1158
Diameter of Pitch-line of Wheels from 10 to 100 Teeth.....	1159
Chordal Pitch.....	1159
Proportions of Teeth.....	1159
Gears with Short Teeth.....	1160
Formulæ for Dimensions of Teeth.....	1160
Width of Teeth.....	1161
Proportions of Gear-wheels.....	1161
Rules for Calculating the Speed of Gears and Pulleys.....	1162
Milling Cutters for Interchangeable Gears.....	1162

**Forms of the Teeth.**

The Cycloidal Tooth.....	1162
The Involute Tooth.....	1165

	PAGE
Approximation by Circular Arcs.....	1166
Stub Gear Teeth for Automobiles.....	1167
Stepped Gears.....	1168
Twisted Teeth.....	1168
Spiral Gears.....	1168
Worm Gearing.....	1168
The Hindley Worm.....	1169
Teeth of Bevel-wheels.....	1169
Annular and Differential Gearing.....	1169
Efficiency of Gearing.....	1170
Efficiency of Worm Gearing.....	1171
Efficiency of Automobile Gears.....	1172

### Strength of Gear Teeth.

Various Formulæ for Strength.....	1172
Comparison of Formulæ.....	1174
Raw-hide Pinions.....	1177
Maximum Speed of Gearing.....	1177
A Heavy Machine-cut Spur-gear.....	1178
Frictional Gearing.....	1178
Frictional Grooved Gearing.....	1178
Power Transmitted by Friction Drives.....	1178
Friction Clutches.....	1179
Coil Friction Clutches.....	1180

### HOISTING AND CONVEYING.

Working Strength of Blocks.....	1181
Chain-blocks.....	1181
Efficiency of Hoisting Tackle.....	1182
Proportions of Hooks.....	1182
Heavy Crane Hooks.....	1183
Strength of Hooks and Shackles.....	1184
Power of Hoisting Engines.....	1184
Effect of Slack Rope on Strain in Hoisting.....	1186
Limit of Depth for Hoisting.....	1186
Large Hoisting Records.....	1186
Safe Loads for Ropes and Chains.....	1187
Pneumatic Hoisting.....	1187
Counterbalancing of Winding-engines.....	1188

### Cranes.

Classification of Cranes.....	1189
Position of the Inclined Brace in a Jib Crane.....	1190
Electric Overhead Traveling Cranes.....	1190
Power Required to Drive Cranes.....	1191
Dimensions, Loads and Speeds of Electric Cranes.....	1191
Notable Crane Installations.....	1192
A 150-ton Pillar Crane.....	1192
Compressed-air Traveling Cranes.....	1192
Electric <i>versus</i> Hydraulic Cranes.....	1193
Power Required for Traveling Cranes and Hoists.....	1193
<b>Lifting Magnets</b> .....	1193
<b>Telpherage</b> .....	1196

### Coal-handling Machinery.

Weight of Overhead Bins.....	1196
Supply-pipes from Bins.....	1196
Types of Coal Elevators.....	1196
Combined Elevators and Conveyors.....	1197
Coal Conveyors.....	1197
Horse-power of Conveyors.....	1198

	PAGE
Bucket, Screw, and Belt Conveyors.....	1198
Weight of Chain and of Flights.....	1199
Capacity of Belt Conveyors.....	1199
Belt Conveyor Construction.....	1200
Horse-power to Drive Belt Conveyors.....	1200
Relative Wearing Power of Conveyor Belts.....	1200
Pneumatic Conveying.....	1201
Pneumatic Postal Transmission.....	1201

### Wire-rope Haulage.

Self-acting Inclined Plane.....	1202
Simple Engine Plane.....	1203
Tail-rope System.....	1203
Endless Rope System.....	1203
Wire-rope Tramways.....	1204
Stress in Hoisting-ropes on Inclined Planes.....	1204
An Aerial Tramway 21 miles long.....	1205
Suspension Cableways and Cable Hoists.....	1205
Tension Required to Prevent Wire Slipping on Drums.....	1206
Formulæ for Deflection of a Wire Cable.....	1207
Taper Ropes of Uniform Tensile Strength.....	1208

### WIRE-ROPE TRANSMISSION.

Working Tension of Wire Ropes.....	1208
Sheaves for Wire-rope Transmission.....	1208
Breaking Strength of Wire Ropes.....	1209
Bending Stresses of Wire Ropes.....	1209
Horse-power Transmitted.....	1210
Diameters of Minimum Sheaves.....	1211
Deflection of the Rope.....	1211
Limits of Span.....	1212
Long-distance Transmission.....	1212
Inclined Transmissions.....	1212
Bending Curvature of Wire Ropes.....	1213

### ROPE-DRIVING.

Formulæ for Rope-driving.....	1214
Horse-power of Transmission at Various Speeds.....	1215
Sag of the Rope between Pulleys.....	1216
Tension on the Slack Part of the Rope.....	1216
Miscellaneous Notes on Rope-driving.....	1217
Data of Manila Transmission Rope.....	1218
Cotton Ropes.....	1218

### FRICTION AND LUBRICATION.

Coefficient of Friction.....	1219
Rolling Friction.....	1219
Friction of Solids.....	1219
Friction of Rest.....	1219
Laws of Unlubricated Friction.....	1219
Friction of Tires Sliding on Rails.....	1219
Coefficient of Rolling Friction.....	1220
Laws of Fluid Friction.....	1220
Angles of Repose of Building Materials.....	1220
Coefficient of Friction of Journals.....	1220
Friction of Motion.....	1221
Experiments on Friction of a Journal.....	1221
Coefficients of Friction of Journal with Oil Bath.....	1221, 1223
Coefficients of Friction of Motion and of Rest.....	1222
Value of Anti-friction Metals.....	1223
Cast-iron for Bearings.....	1223

	PAGE
Friction of Metal under Steam-pressure.....	1223
Morin's Laws of Friction.....	1223
Laws of Friction of Well-lubricated Journals.....	1225
Allowable Pressures on Bearing-surfaces.....	1226
Oil-pressure in a Bearing.....	1228
Friction of Car-journal Brasses.....	1228
Experiments on Overheating of Bearings.....	1228
Moment of Friction and Work of Friction.....	1229
Tests of Large Shaft Bearings.....	1230
Clearance between Journal and Bearing.....	1230
Allowable Pressures on Bearings.....	1230
Bearing Pressures for Heavy Intermittent Loads.....	1231
Bearings for Very High Rotative Speed.....	1231
Bearing Pressures in Shafts of Parsons Turbine.....	1232
Thrust Bearings in Marine Practice.....	1232
Bearings for Locomotives.....	1232
Bearings of Corliss Engines.....	1232
Temperature of Engine Bearings.....	1232
Pivot Bearings.....	1232
The Schiele Curve.....	1232
Friction of a Flat Pivot-bearing.....	1233
Mercury-bath Pivot.....	1233
Ball Bearings, Roller Bearings, etc.....	1233
Friction Rollers.....	1233
Conical Roller Thrust Bearings.....	1234
The Hyatt Roller Bearing.....	1235
Notes on Ball Bearings.....	1235
Saving of Power by Use of Ball Bearings.....	1237
Knife-edge Bearings.....	1238
Friction of Steam-engines.....	1238
Distribution of the Friction of Engines.....	1238

### Friction Brakes and Friction Clutches.

Friction Brakes.....	1239
Friction Clutches.....	1239
Magnetic and Electric Brakes.....	1240
Design of Band Brakes.....	1240
<b>Friction of Hydraulic Plunger Packing.....</b>	<b>1241</b>

### Lubrication.

Durability of Lubricants.....	1241
Qualifications of Lubricants.....	1242
Examination of Oils.....	1242
Specifications for Petroleum Lubricants.....	1243
Penna. R. R. Specifications.....	1244
Grease Lubricants.....	1244
Testing Oil for Steam Turbines.....	1244
Quantity of Oil to Run an Engine.....	1245
Cylinder Lubrication.....	1245
Soda Mixture for Machine Tools.....	1246
Water as a Lubricant.....	1246
Acheson's Deflocculated Graphite.....	1246
Solid Lubricants.....	1246
Graphite, Soapstone, Metaline.....	1246

### THE FOUNDRY.

Cupola Practice.....	1247
Melting Capacity of Different Cupolas.....	1248
Charging a Cupola.....	1248
Improvement of Cupola Practice.....	1249
Charges in Stove Foundries.....	1250
Foundry Blower Practice.....	1250



	PAGE
Results of Increased Driving.....	1252
Power Required for a Cupola Fan.....	1253
Utilization of Cupola Gases.....	1253
Loss of Iron in Melting.....	1253
Use of Softeners.....	1253
Weakness of Large Castings.....	1253
Shrinkage of Castings.....	1254
Growth of Cast Iron by Heating.....	1254
Hard Iron due to Excessive Silicon.....	1254
Ferro Alloys for Foundry Use.....	1255
Dangerous Ferro-silicon.....	1255
Quality of Foundry Coke.....	1255
Castings made in Permanent Cast-iron Molds.....	1255
Weight of Castings from Weight of Pattern.....	1256
Molding Sand.....	1256
Foundry Ladles.....	1257

### THE MACHINE-SHOP.

Speed of Cutting Tools.....	1258
Table of Cutting Speeds.....	1258
Spindle Speeds of Lathes.....	1259
Rule for Gearing Lathes.....	1259
Change-gears for Lathes.....	1260
Quick Change Gears.....	1260
Metric Screw-threads.....	1261
Cold Chisels.....	1261
Setting the Taper in a Lathe.....	1261
Lubricants for Lathe Centers.....	1261
Taylor's Experiments on Tool Steel.....	1261
Proper Shape of Lathe Tool.....	1261
Forging and Grinding Tools.....	1263
Best Grinding Wheel for Tools.....	1263
Chatter.....	1264
Use of Water on Tool.....	1264
Interval between Grindings.....	1264
Effect of Feed and Depth of Cut on Speed.....	1264
Best High Speed Tool Steel—Heat Treatment.....	1265
Table, Cutting Speeds of Taylor-White Tools.....	1266
Best Method of Treating Tools in Small Shops.....	1268
Quality of Different Tool Steels.....	1268
Parting and Thread Tools.....	1268
Durability of Cutting Tools.....	1268
Economical Cutting Speeds.....	1268
New High Speed Steels, 1909.....	1269
Stellite.....	1269
Planer Work.....	1270-1275
Cutting and Return Speeds of Planers.....	1270
Power Required for Planing.....	1270
Time Required for Planing.....	1271
Standard Planer Tools.....	1271-1275
Milling Machine Practice.....	1275-1284
Forms of Milling Cutters.....	1275
Number of Teeth in Milling Cutters.....	1276
Keyways in Milling Cutters.....	1277
Power Required for Milling.....	1278
Modern Milling Practice, 1914.....	1279
Milling with or against the Feed.....	1280
Lubricant for Milling Cutters.....	1281
Typical Milling Jobs, Speeds, Feeds.....	1281
High-speed Milling.....	1282
Limiting Factors of Milling Practice.....	1283
Speeds and Feeds for Gear Cutting.....	1284
Drills and Drilling.....	1285-1290
Forms of Drills.....	1285
Drilling Compounds.....	1286



	PAGE
Twist Drill and Steel Wire Gages.....	1286
Power Required to Drive Drills.....	1286, 1287
Feeds and Speeds of Drills.....	1288
Extreme Results with Drills.....	1289
Experiments on Twist Drills.....	1289
Cutting Speeds for Tapping and Threading.....	1290
Sawing Metals.....	1291
Case-hardening, Cementation, Harveyizing.....	1291
Change of Shape due to Hardening and Tempering.....	1291

### Power Required for Machine Tools.

Resistance Overcome in Cutting Metal.....	1292
Power Required to Run Lathes.....	1292-1295
Sizes of Motors for Machine Tools.....	1294-1298
Horse-power Constants for Cutting Metals.....	1299
Pulley Diameters for Motors.....	1300
Geared Connections for Motors, Table.....	1301
Motor Requirements for Planers.....	1302
Tests on a Motor-driven Planer.....	1303
Power Required for Wood-working Machinery.....	1303
Power Required to Drive Shafting.....	1305
Power Required to Drive Machines in Groups.....	1305
Machine Tool Drives, Speeds and Feeds.....	1307
Geometrical Progression of Speeds and Feeds.....	1307
Methods of Driving Machine Tools.....	1307

### Abrasive Processes.

The Cold Saw.....	1309
Reese's Fusing-disk.....	1309
Cutting Stone with Wire.....	1309
The Sand-blast.....	1309
Polishing and Buffing.....	1310
Laps and Lapping.....	1310
Emery-wheels.....	1311-1317
Artificial Abrasives.....	1313
Mounting Grinding Wheels, Safety Devices.....	1314
Grinding as a Substitute for Finish Turning.....	1317
Grindstones.....	1317

### Various Tools and Processes.

Taper Bolts, Pins, Reamers, etc.....	1318
Morse Tapers.....	1319
Jarno Taper.....	1319
Tap Drills.....	1320
Taper Pins.....	1321
T-slots, T-bolts and T-nuts.....	1321
Punches and Dies, Presses, etc.....	1321
Punch and Die Clearances.....	1321
Kennedy's Spiral Punch.....	1322
Sizes of Blanks Used in the Drawing Press.....	1322
Pressure Obtained by the Drop Press.....	1322
Flow of Metals.....	1323
Fly-wheels for Presses, Punches, Shears, etc.....	1323
Forcing, Shrinking, and Running Fits.....	1324
Pressures for Mounting Wheels and Crank Pins.....	1324
Fits for Machine Parts.....	1325
Running Fits.....	1325
Shop Allowances for Electrical Machinery.....	1326
Pressure Required for Press Fits.....	1326
Stresses due to Force and Shrink Fits.....	1326
Force Required to Start Force and Shrink Fits.....	1327
Formulæ for Flat and Square Keys.....	1328

	PAGE
Keys of Various Forms.....	1328-1331
Depth of Key Seats.....	1329
Gib Keys.....	1332
Holding Power of Keys and Set Screws.....	1332

### DYNAMOMETERS.

Traction Dynamometers.....	1333
The Prony Brake.....	1333
The Alden Dynamometer.....	1334
Capacity of Friction-brakes.....	1334
Transmission Dynamometers.....	1335

### ICE MAKING OR REFRIGERATING-MACHINES.

Operations of a Refrigerating-Machine.....	1336
Pressures, etc., of Available Liquids.....	1337
Properties of Sulphur Dioxide Gas.....	1338
Properties of Ammonia.....	1339, 1340
Solubility of Ammonia.....	1341
Properties of Saturated Vapors.....	1341
Heat Generated by Absorption of Ammonia.....	1341
Cooling Effect, Compressor Volume and Power Required, with Different Cooling Agents.....	1341
Ratios of Condenser, Mean Effective, and Vaporizer Pressures..	1342
Properties of Brine used to absorb Refrigerating Effect.....	1343
Chloride-of-calcium Solution.....	1343
Ice-melting Effect.....	1344
Ether-machines.....	1344
Air-machines.....	1344
Carbon Dioxide Machines.....	1344
Methyl Chloride Machines.....	1345
Sulphur-dioxide Machines.....	1345
Machines Using Vapor of Water.....	1345
Ammonia Compression-machines.....	1345
Dry, Wet and Flooded Systems.....	1345
Ammonia Absorption-machines.....	1346
Relative Performance of Compression and Absorption Machines	1346
Efficiency of a Refrigerating-machine.....	1347
Diagrams of Ammonia Machine Operation.....	1348
Cylinder-heating.....	1349
Volumetric Efficiency.....	1349
Pounds of Ammonia per Ton of Refrigeration.....	1350, 1351
Mean Effective Pressure, and Horse-power.....	1350
The Voorhees Multiple Effect Compressor.....	1350
Size and Capacities of Ammonia Machines.....	1352
Piston Speeds and Revolutions per Minute.....	1353
Condensers for Refrigerating-machines.....	1353
Cooling Tower Practice in Refrigerating Plants.....	1354
Test Trials of Refrigerating-machines.....	1355
Comparison of Actual and Theoretical Capacity.....	1355
Performance of Ammonia Compression-machines.....	1356
Economy of Ammonia Compression-machines.....	1357
Form of Report of Test.....	1358
Temperature Range.....	1359
Metering the Ammonia.....	1359
Performance of Ice-making Machines.....	1359
Performance of a 75-ton Refrigerating-machine.....	1361-1363
Ammonia Compression-machine, Results of Tests.....	1364
Performance of a Single-acting Ammonia Compressor.....	1364
Performance of Ammonia Absorption-machine.....	1364
Means for Applying the Cold.....	1365
Artificial Ice-manufacture.....	1366
Test of the New York Hygeia Ice-making Plant.....	1367
An Absorption Evaporator Ice-making System.....	1367
Ice-making with Exhaust Steam.....	1367

	PAGE
Tons of Ice per Ton of Coal.....	1367
Standard Ice Cans or Molds.....	1368
Cubic Feet of Insulated Space per Ton Refrigeration.....	1368

### MARINE ENGINEERING.

Rules for Measuring and Obtaining Tonnage of Vessels.....	1368
The Displacement of a Vessel.....	1369
Coefficient of Fineness.....	1369
Coefficient of Water-line.....	1369
Resistance of Ships.....	1369
Coefficient of Performance of Vessels.....	1370
Defects of the Common Formula for Resistance.....	1370
Rankine's Formula.....	1370
Empirical Equations for Wetted Surface.....	1371
E. R. Mumford's Method.....	1371
Dr. Kirk's Method.....	1372
To find the I.H.P. from the Wetted Surface.....	1372
Relative Horse-power required for Different Speeds of Vessels..	1373
Resistance per Horse-power for Different Speeds.....	1373
Estimated Displacement, Horse-power, etc., of Steam-vessels...	1374
Speed of Boats with Internal Combustion Engines.....	1374
Data of Ships of Various Types.....	1376
Relation of Horse-power to Speed.....	1376

### The Screw-propeller.

Pitch and Size of Screw.....	1377
Propeller Coefficients.....	1378
Efficiency of the Propeller.....	1379
Pitch-ratio and Slip for Screws of Standard Form.....	1379
Table for Calculating Dimensions of Screws.....	1380

### Marine Practice.

Comparison of Marine Engines, 1872, 1881, 1891, 1901.....	1380
Turbines and Boilers of the "Lusitania".....	1381
Performance of the "Lusitania," 1908.....	1381
Dimensions and Performance of Notable Atlantic Steamers...	1382
Relative Economy of Turbines and Reciprocating Engines.....	1382
Reciprocating Engines with a Low-pressure Turbine.....	1383

### The Paddle-wheel.

Paddle-wheels with Radial Floats.....	1383
Feathering Paddle-wheels.....	1383
Efficiency of Paddle-wheels.....	1384

### Jet Propulsion.

Reaction of a Jet.....	1384
------------------------	------

## CONSTRUCTION OF BUILDINGS.

### Foundations.

Bearing Power of Soils.....	1385
Bearing Power of Piles.....	1386
Safe Strength of Brick Piers.....	1386
Thickness of Foundation Walls.....	1386

### Masonry.

Allowable Pressures on Masonry.....	1386
Crushing Strength of Concrete.....	1386
Reinforced Concrete.....	1386

**Beams and Girders.**

	PAGE
Safe Loads on Beams.....	1387
Safe Loads on Wooden Beams.....	1387
Maximum Permissible Stresses in Structural Materials.....	1388

**Walls.**

Thickness of Walls of Buildings.....	1388
Walls of Warehouses, Stores, Factories, and Stables.....	1388

**Floors, Columns and Posts.**

Strength of Floors, Roofs, and Supports.....	1389
Columns and Posts.....	1389
Fireproof Buildings.....	1389
Iron and Steel Columns.....	1389
Lintels, Bearings, and Supports.....	1390
Strains on Girders and Rivets.....	1390
Maximum Load on Floors.....	1390
Strength of Floors.....	1391
Maximum Spans for 1, 2 and 3 inch Plank.....	1392
Mill Columns.....	1393
Safe Distributed Loads on Southern-pine Beams.....	1393
Approximate Cost of Mill Buildings.....	1394

**ELECTRICAL ENGINEERING.**

C. G. S. System of Physical Measurement.....	1396
Practical Units used in Electrical Calculations.....	1396
Relations of Various Units.....	1397
Units of the Magnetic Circuit.....	1398
Equivalent Electrical and Mechanical Units.....	1399
Permeability.....	1400
Analogies between Flow of Water and Electricity.....	1400

**Electrical Resistance.**

Laws of Electrical Resistance.....	1400
Electrical Conductivity of Different Metals and Alloys.....	1401
Conductors and Insulators.....	1402
Resistance Varies with Temperature.....	1402
Annealing.....	1402
Standard of Resistance of Copper Wire.....	1402
Wire Table, Standard Annealed Copper.....	1404

**Direct Electric Currents.**

Ohm's Law.....	1406
Series and Parallel or Multiple Circuits.....	1406
Resistance of Conductors in Series and Parallel.....	1407
Internal Resistance.....	1408
Power of the Circuit.....	1408
Electrical, Indicated, and Brake Horse-power.....	1408
Heat Generated by a Current.....	1408
Heating of Conductors.....	1409
Heating of Coils.....	1409
Fusion of Wires.....	1409
Allowable Carrying Capacity of Copper Wires.....	1410
Underwriters' Insulation.....	1410

**Electric Transmission, Direct-Currents.**

Drop of Voltage in Wires Carrying Allowed Currents.....	1410
Section of Wire Required for a Given Current.....	1410
Weight of Copper for a Given Power.....	1411



	PAGE
Short-circuiting.....	1411
Economy of Electric Transmission.....	1411
Efficiency of Electric Systems.....	1412
Wire Table for 110, 220, 500, 1000, and 2000 volt Circuits.....	1413
Resistances of Pure Aluminum Wire.....	1414
<b>Electric Railways.</b>	
Schedule Speeds, Miles per Hour.....	1414
Train Resistance.....	1415
Rates of Acceleration.....	1415
Safe Maximum Speed on Curves.....	1416
Electric Resistance of Rails and Bonds.....	1416
Electric Locomotives.....	1416
Efficiencies of Distributing Systems.....	1417
Steam Railroad Electrifications.....	1418
<b>Electric Welding.</b>	
Arc Welding.....	1419
Data of Electric Welding in Railway Shops.....	1419
Resistance Welding.....	1419
Cost of Welding.....	1420
<b>Electric Heaters.</b>	
Elementary Form of Heater.....	1420
Relative Efficiency of Electric and Steam Heating.....	1421
Heat Required to Warm and Ventilate a Room.....	1421
Domestic Heating.....	1421
<b>Electric Furnaces.</b>	
Arc Furnaces and Resistance Furnaces.....	1422
Uses of Electric Furnaces.....	1423
Electric Smelting of Pig-iron.....	1424
Ferro-alloys.....	1424
Non-ferrous Metals.....	1424
<b>Electric Batteries.</b>	
Primary Batteries.....	1425
Description of Storage-batteries or Accumulators.....	1425
Rules for Care of Storage-batteries.....	1426
Efficiency of a Storage Cell.....	1427
Uses of Storage-batteries.....	1427
Edison Alkaline Battery.....	1428
<b>Electrolysis</b> .....	1428
<b>Electro-chemical Equivalents</b> .....	1429
<b>The Magnetic Circuit.</b>	
Lines and Loops of Force.....	1430
Values of <i>B</i> and <i>H</i> .....	1431
Tractive or Lifting Force of a Magnet.....	1431
Determining the Polarity of Electro-magnets.....	1432
Determining the Direction of a Current.....	1432
<b>Dynamo-electric Machines.</b>	
Rating of Generators and Motors.....	1432
Temperature Limitations of Capacity.....	1433
Methods of Determining Temperatures.....	1434
Temperature Limits of Hottest Spot.....	1434
Moving Force of a Dynamo-electric Machine.....	1435



	PAGE
Torque of an Armature.....	1435
Torque, Horse-power and Revolutions.....	1436
Electro-motive Force of the Armature Circuit.....	1436
Strength of the Magnetic Field.....	1436

### Direct-Current Generators.

Series-, Shunt- and Compound-wound.....	1437
Commutating Pole Machines.....	1438
Parallel Operation.....	1439
Three-Wire System.....	1439

### Alternating Currents.

Maximum, Average and Effective Values.....	1440
Frequency.....	1440
Inductance.....	1440
Capacity.....	1440
Power Factor.....	1440
Reactance, Impedance, Admittance.....	1441
Skin Effect.....	1442
Ohm's Law Applied to Alternating Current Circuits.....	1442
Impedance Polygons.....	1442
Self-inductance of Lines and Circuits.....	1446
Capacity of Conductors.....	1446
Single-phase and Polyphase Currents.....	1446
Measurement of Power in Polyphase Circuits.....	1447

### Alternating Current Generators.

Synchronous Generators.....	1448
Rating.....	1448
Efficiency.....	1448
Regulation.....	1449
Rating of a Generator Unit.....	1449
Windings.....	1449
Voltagcs.....	1450
Parallel Operation.....	1450
Exciters.....	1450

### Transformers.

Primary and Secondary.....	1451
Voltage Ratio.....	1451
Rating.....	1451
Efficiency.....	1451
Connections.....	1452
Auto Transformers.....	1453
Constant-Current Transformers.....	1453

### Synchronous Converters.

Description.....	1453
Effective E.M.F. between Collector Rings.....	1454
Voltage Regulation.....	1455
Starting Synchronous Converters.....	1455

### Motor-Generators.

Balancers.....	1456
Boosters.....	1456
Dynamotors.....	1457
Frequency Changers.....	1457
Mercury Arc Rectifier.....	1457

**Alternating Current Circuits.**

	PAGE
Calculation of Alternating Current Circuits.....	1457
Relative Weight of Copper Required in Different Systems.....	1459
Rule for Size of Wires for Three-phase Transmission Lines.....	1459
Notes on High-tension Transmission.....	1459
Voltages Advisable for Various Line Lengths.....	1460
Line Spacing.....	1460
Size of Line Conductors.....	1460
A 135,000-volt Three-phase Transmission System.....	1461

**Electric Motors.**

Classification of Motors.....	1461
Characteristics of Motors.....	1461
Series Motor.....	1461
Speed Control of Motors.....	1462
Shunt Motor.....	1462
Compound Motor.....	1462
Induction Motor; Squirrel-cage Motor.....	1463
Multi-speed Induction Motors.....	1463
Synchronous Motors.....	1463
Single-phase Series Motor.....	1464
Repulsion Induction Motor.....	1464
Reversible Repulsion Motor.....	1464
Variable-speed Repulsion Motor.....	1464

**Motor Applications.**

Pumps.....	1464
Fans.....	1465
Air Compressors.....	1465
Hoists.....	1465
Machine Tools.....	1466
Motors for Machine Tools.....	1467

**Illumination—Electric and Gas Lighting.**

Illumination.....	1468
Terms, Units, Definitions.....	1468
Relative Color Values of Illuminants.....	1469
Relation of Illumination to Vision.....	1469
Types of Electric Lamps.....	1470
Street Lighting.....	1470
Illumination by Arc Lamps at Different Distances.....	1471
Data of Some Arc Lamps.....	1471
Relative Efficiency of Illuminants.....	1472
Characteristics of Tungsten Lamps.....	1473
Interior Illumination.....	1473
Quantity of Electricity or Gas Required for Illuminating.....	1474
Standard Units; Mazda and Welsbach.....	1475
Cost of Electric Lighting.....	1475
Recent Street Lighting Installations.....	1476
Symbols Used in Electric Diagrams.....	1477



## NAMES AND ABBREVIATIONS OF PERIODICALS AND TEXT-BOOKS FREQUENTLY REFERRED TO IN THIS WORK.

---

- Am. Mach. American Machinist.  
App. Cyl. Mech. Appleton's Cyclopædia of Mechanics, Vols. I and II.  
Bull. I. & S. A. Bulletin of the American Iron and Steel Association.  
Burr's Elasticity and Resistance of Materials.  
Clark, R. T. D. D. K. Clark's Rules, Tables, and Data for Mechanical Engineers.  
Clark, S. E. D. K. Clark's Treatise on the Steam-Engine.  
Col. Coll. Qly. Columbia College Quarterly.  
El. Rev. Electrical Review.  
El. World. Electrical World and Engineer.  
Engg. Engineering (London).  
Eng. News. Engineering News.  
Eng. Rec. Engineering Record.  
Engr. The Engineer (London).  
Fairbairn's Useful Information for Engineers.  
Flynn's Irrigation Canals and Flow of Water.  
Indust. Eng. Industrial Engineering.  
Jour. A. C. I. W. Journal of American Charcoal Iron Workers' Association.  
Jour. Ass. Eng. Soc. Journal of the Association of Engineering Societies.  
Jour. F. I. Journal of the Franklin Institute.  
Lanza's Applied Mechanics.  
Machy. Machinery.  
Merriman's Strength of Materials.  
Modern Mechanism. Supplementary volume of Appleton's Cyclopædia of Mechanics.  
Peabody's Thermodynamics.  
Proc. A. S. H. V. E. Proceedings Am. Soc'y of Heating and Ventilating Engineers.  
Proc. A. S. T. M. Proceedings Amer. Soc'y for Testing Materials.  
Proc. Inst. C. E. Proceedings Institution of Civil Engineers (London).  
Proc. Inst. M. E. Proceedings Institution of Mechanical Engineers (London).  
Proceedings Engineers' Club of Philadelphia.  
Rankine, S. E. Rankine's The Steam Engine and other Prime Movers.  
Rankine's Machinery and Millwork.  
Rankine, R. T. D. Rankine's Rules, Tables, and Data.  
Reports of U. S. Iron and Steel Test Board.  
Reports of U. S. Testing Machine at Watertown, Massachusetts.  
Rontgen's Thermodynamics.  
Seaton's Manual of Marine Engineering.  
Hamilton Smith, Jr.'s Hydraulics.  
Stevens Indicator.  
Thompson's Dynamo-electric Machinery.  
Thurston's Manual of the Steam Engine.  
Thurston's Materials of Engineering.  
Trans. A. I. E. E. Transactions American Institute of Electrical Engineers.  
Trans. A. I. M. E. Transactions American Institute of Mining Engineers.  
Trans. A. S. C. E. Transactions American Society of Civil Engineers.  
Trans. A. S. M. E. Transactions American Society of Mechanical Engineers.  
Trautwine's Civil Engineer's Pocket Book.  
The Locomotive (Hartford, Connecticut).  
Unwin's Elements of Machine Design.  
Weisbach's Mechanics of Engineering.  
Wood's Resistance of Materials.  
Wood's Thermodynamics.

# MATHEMATICS.

## Greek Letters.

<b>A</b> $\alpha$ Alpha <b>B</b> $\beta$ Beta <b><math>\Gamma</math></b> $\gamma$ Gamma <b><math>\Delta</math></b> $\delta$ Delta <b>E</b> $\epsilon$ Epsilon <b>Z</b> $\zeta$ Zeta	<b>H</b> $\eta$ Eta <b><math>\Theta</math></b> $\theta$ Theta <b>I</b> $\iota$ Iota <b>K</b> $\kappa$ Kappa <b><math>\Lambda</math></b> $\lambda$ Lambda <b>M</b> $\mu$ Mu	<b>N</b> $\nu$ Nu <b><math>\Xi</math></b> $\xi$ Xi <b>O</b> $\omicron$ Omicron <b><math>\Pi</math></b> $\pi$ Pi <b>P</b> $\rho$ Rho <b><math>\Sigma</math></b> $\sigma$ Sigma	<b>T</b> $\tau$ Tau <b>Y</b> $\upsilon$ Upsilon <b><math>\Phi</math></b> $\phi$ Phi <b>X</b> $\chi$ Chi <b><math>\Psi</math></b> $\psi$ Psi <b><math>\Omega</math></b> $\omega$ Omega
--	---	--	--

## Arithmetical and Algebraical Signs and Abbreviations.

- + plus (addition).
- + positive.
- minus (subtraction).
- negative.
- $\pm$  plus or minus.
- $\mp$  minus or plus.
- = equals.
- $\times$  multiplied by.
- $ab$  or  $a.b = a \times b$ .
- $\div$  divided by.
- / divided by.
- $\frac{a}{b} = a/b = a \div b$ .  $15-16 = \frac{15}{16}$ .
- $0.2 = \frac{2}{10}$ ;  $0.002 = \frac{2}{1000}$ .
- $\sqrt{\quad}$  square root.
- $\sqrt[3]{\quad}$  cube root.
- $\sqrt[4]{\quad}$  4th root.
- : is to, :: so is, : to (proportion).
- 2 : 4 :: 3 : 6, 2 is to 4 as 3 is to 6.
- : ratio; divided by.
- 2 : 4, ratio of 2 to 4 =  $2/4$ .
- $\therefore$  therefore.
- > greater than.
- < less than.
- $\square$  square.
- $\bigcirc$  round.
- $^{\circ}$  degrees, arc or thermometer.
- ' minutes or feet.
- " seconds or inches.
- ' " " accents to distinguish letters, as  $a'$ ,  $a''$ ,  $a'''$ .
- $a_1, a_2, a_3, a_b, a_c$ , read  $a$  sub 1,  $a$  sub  $b$ , etc.
- ( ) { } ——— parenthesis, brackets, braces, vinculum; denoting that the numbers enclosed are to be taken together; as,  
 $(a + b)c = 4 + 3 \times 5 = 35$ .
- $a^2, a^3$ ,  $a$  squared,  $a$  cubed.
- $a^n$ ,  $a$  raised to the  $n$ th power.
- $a^{\frac{2}{3}} = \sqrt[3]{a^2}$ ,  $a^{\frac{3}{2}} = \sqrt{a^3}$ .
- $a^{-1} = \frac{1}{a}$ ,  $a^{-2} = \frac{1}{a^2}$ .
- $10^9 = 10$  to the 9th power = 1,000,000,000.
- $\sin a$  = the sine of  $a$ .
- $\sin^{-1} a$  = the arc whose sine is  $a$ .
- $\sin a^{-1} = \frac{1}{\sin a}$ .
- log = logarithm.
- $\log_e$  or hyp log = hyperbolic logarithm.
- % per cent.
- $\Delta$  angle.

- L right angle.
- $\perp$  perpendicular to.
- sin, sine.
- cos, cosine.
- tan, tangent.
- sec, secant.
- versin, versed sine.
- cot, cotangent.
- cosec, cosecant.
- covers, co-versed sine.
- In Algebra, the first letters of the alphabet,  $a, b, c, d$ , etc., are generally used to denote known quantities, and the last letters,  $w, x, y, z$ , etc., unknown quantities.
- Abbreviations and Symbols commonly used.*
- $d$ , differential (in calculus).
- $\int$ , integral (in calculus).
- $\int_b^a$ , integral between limits  $a$  and  $b$ .
- $\Delta$ , delta, difference.
- $\Sigma$ , sigma, sign of summation.
- $\pi$ , pi, ratio of circumference of circle to diameter = 3.14159.
- $g$ , acceleration due to gravity = 32.16 ft. per second per second.
- Abbreviations frequently used in this Book.*
- L., l., length in feet and inches.
- B., b., breadth in feet and inches.
- D., d., depth or diameter.
- H., h., height, feet and inches.
- T., t., thickness or temperature.
- V., v., velocity.
- F., force, or factor of safety.
- f., coefficient of friction.
- E., coefficient of elasticity.
- R., r., radius.
- W., w., weight.
- P., p., pressure or load.
- H.P., horse-power.
- I.H.P., indicated horse-power.
- B.H.P., brake horse-power.
- h. p., high pressure.
- i. p., intermediate pressure.
- l. p., low pressure.
- A.W.G., American Wire Gauge (Brown & Sharpe).
- B.W.G., Birmingham Wire Gauge.
- r. p. m., or revs. per min., revolutions per minute.
- Q. = quantity, or volume.



## ARITHMETIC.

The user of this book is supposed to have had a training in arithmetic as well as in elementary algebra. Only those rules are given here which are apt to be easily forgotten.

## GREATEST COMMON MEASURE, OR GREATEST COMMON DIVISOR OF TWO NUMBERS.

**Rule.** — Divide the greater number by the less; then divide the divisor by the remainder, and so on, dividing always the last divisor by the last remainder, until there is no remainder, and the last divisor is the greatest common measure required.

## LEAST COMMON MULTIPLE OF TWO OR MORE NUMBERS.

**Rule.** — Divide the given numbers by any number that will divide the greatest number of them without a remainder, and set the quotients with the undivided numbers in a line beneath.

Divide the second line as before, and so on, until there are no two numbers that can be divided; then the continued product of the divisors, last quotients, and undivided numbers will give the multiple required.

## FRACTIONS.

**To reduce a common fraction to its lowest terms.** — Divide both terms by their greatest common divisor:  $\frac{39}{52} = \frac{3}{4}$ .

**To change an improper fraction to a mixed number.** — Divide the numerator by the denominator; the quotient is the whole number, and the remainder placed over the denominator is the fraction:  $\frac{39}{4} = 9\frac{3}{4}$ .

**To change a mixed number to an improper fraction.** — Multiply the whole number by the denominator of the fraction; to the product add the numerator; place the sum over the denominator:  $17\frac{7}{8} = \frac{15}{8}$ .

**To express a whole number in the form of a fraction with a given denominator.** — Multiply the whole number by the given denominator, and place the product over that denominator:  $13 = \frac{39}{3}$ .

**To reduce a compound to a simple fraction, also to multiply fractions.** — Multiply the numerators together for a new numerator and the denominators together for a new denominator:

$$\frac{2}{3} \text{ of } \frac{4}{3} = \frac{8}{9}, \text{ also } \frac{2}{3} \times \frac{4}{3} = \frac{8}{9}.$$

**To reduce a complex to a simple fraction.** — The numerator and denominator must each first be given the form of a simple fraction; then multiply the numerator of the upper fraction by the denominator of the lower for the new numerator, and the denominator of the upper by the numerator of the lower for the new denominator:

$$\frac{7/8}{13/4} = \frac{7/8}{7/4} = \frac{28}{56} = \frac{1}{2}.$$

**To divide fractions.** — Reduce both to the form of simple fractions, invert the divisor, and proceed as in multiplication:

$$\frac{3}{4} \div 1\frac{1}{4} = \frac{3}{4} \div \frac{5}{4} = \frac{3}{4} \times \frac{4}{5} = \frac{12}{20} = \frac{3}{5}.$$

**Cancellation of fractions.** — In compound or multiplied fractions, divide any numerator and any denominator by any number which will divide them both without remainder, striking out the numbers thus divided and setting down the quotients in their stead.

**To reduce fractions to a common denominator.** — Reduce each fraction to the form of a simple fraction; then multiply each numerator

By all the denominators except its own for the new numerator, and all the denominators together for the common denominator:

$$\frac{1}{2}, \frac{1}{3}, \frac{3}{7} = \frac{21}{42}, \frac{14}{42}, \frac{18}{42}.$$

**To add fractions.** — Reduce them to a common denominator, then add the numerators and place their sum over the common denominator:

$$\frac{1}{2} + \frac{1}{3} + \frac{3}{7} = \frac{21 + 14 + 18}{42} = \frac{53}{42} = 1\frac{11}{42}.$$

**To subtract fractions.** — Reduce them to a common denominator, subtract the numerators and place the difference over the common denominator:

$$\frac{1}{2} - \frac{3}{7} = \frac{7 - 6}{14} = \frac{1}{14}.$$

## DECIMALS.

**To add decimals.** — Set down the figures so that the decimal points are one above the other, then proceed as in simple addition:  $18.75 + 0.012 = 18.762$ .

**To subtract decimals.** — Set down the figures so that the decimal points are one above the other, then proceed as in simple subtraction:  $18.75 - 0.012 = 18.738$ .

**To multiply decimals.** — Multiply as in multiplication of whole numbers, then point off as many decimal places as there are in multiplier and multiplicand taken together:  $1.5 \times 0.02 = .030 = 0.03$ .

**To divide decimals.** — Divide as in whole numbers, and point off in the quotient as many decimal places as those in the dividend exceed those in the divisor. Ciphers must be added to the dividend to make its decimal places at least equal those in the divisor, and as many more as it is desired, to have in the quotient:  $1.5 \div 0.25 = 6$ .  $0.1 \div 0.3 = 0.10000 \div 0.3 = 0.3333 +$ .

## Decimal Equivalents of Fractions of One Inch.

1-64	.015625	17-64	.265625	33-64	.515625	49-64	.765625
1-32	.03125	9-32	.28125	17-32	.53125	25-32	.78125
3-64	.046875	19-64	.296875	35-64	.546875	51-64	.796875
1-16	.0625	5-16	.3125	9-16	.5625	13-16	.8125
5-64	.078125	21-64	.328125	37-64	.578125	53-64	.828125
3-32	.09375	11-32	.34375	19-32	.59375	27-32	.84375
7-64	.109375	23-64	.359375	39-64	.609375	55-64	.859375
1-8	.125	3-8	.375	5-8	.625	7-8	.875
9-64	.140625	25-64	.390625	41-64	.640625	57-64	.890625
5-32	.15625	13-32	.40625	21-32	.65625	29-32	.90625
11-64	.171875	27-64	.421875	43-64	.671875	59-64	.921875
3-16	.1875	7-16	.4375	11-16	.6875	15-16	.9375
13-64	.203125	29-64	.453125	45-64	.703125	61-64	.953125
7-32	.21875	15-32	.46875	23-32	.71875	31-32	.96875
15-64	.234375	31-64	.484375	47-64	.734375	63-64	.984375
1-4	.25	1-2	.50	3-4	.75	1	1.

**To convert a common fraction into a decimal.** — Divide the numerator by the denominator, adding to the numerator as many ciphers prefixed by a decimal point as are necessary to give the number of decimal places desired in the result:  $\frac{1}{3} = 1.0000 \div 3 = 0.3333 +$ .

**To convert a decimal into a common fraction.** — Set down the decimal as a numerator, and place as the denominator 1 with as many ciphers annexed as there are decimal places in the numerator; erase the

ARITHMETIC.

Product of Fractions Expressed in Decimals.

0	1	$\frac{1}{16}$	$\frac{1}{8}$	$\frac{3}{16}$	$\frac{1}{4}$	$\frac{5}{16}$	$\frac{3}{8}$	$\frac{7}{16}$	$\frac{1}{2}$	$\frac{9}{16}$	$\frac{5}{8}$	$\frac{11}{16}$	$\frac{3}{4}$	$\frac{13}{16}$	$\frac{7}{8}$	$\frac{15}{16}$	1
$\frac{1}{16}$	.0625	.0039															
$\frac{1}{8}$	.1250	.0078	.0156														
$\frac{3}{16}$	.1875	.0117	.0234	.0352													
$\frac{1}{4}$	.2500	.0156	.0313	.0469	.0625												
$\frac{5}{16}$	.3125	.0195	.0391	.0586	.0781	.0977											
$\frac{3}{8}$	.3750	.0234	.0469	.0703	.0937	.1172	.1406										
$\frac{7}{16}$	.4375	.0273	.0547	.0820	.1093	.1367	.1641	.1914									
$\frac{1}{2}$	.5000	.0313	.0625	.0938	.1250	.1562	.1875	.2188	.2500								
$\frac{9}{16}$	.5625	.0352	.0703	.1055	.1406	.1758	.2109	.2461	.2813	.3164							
$\frac{5}{8}$	.6250	.0391	.0781	.1172	.1562	.1953	.2344	.2734	.3125	.3516	.3906						
$\frac{11}{16}$	.6875	.0430	.0859	.1289	.1719	.2148	.2578	.3008	.3438	.3867	.4297	.4727					
$\frac{3}{4}$	.7500	.0469	.0938	.1406	.1875	.2344	.2813	.3281	.3750	.4219	.4688	.5156	.5625				
$\frac{13}{16}$	.8125	.0508	.1016	.1523	.2031	.2539	.3047	.3555	.4063	.4570	.5078	.5586	.6094	.6601			
$\frac{7}{8}$	.8750	.0547	.1094	.1641	.2187	.2734	.3281	.3828	.4375	.4922	.5469	.6016	.6563	.7109	.7656		
$\frac{15}{16}$	.9375	.0586	.1172	.1758	.2344	.2930	.3516	.4102	.4688	.5273	.5859	.6445	.7031	.7617	.8203	.8789	
1	1.0000	.0625	.1250	.1875	.2500	.3125	.3750	.4375	.5000	.5625	.6250	.6875	.7500	.8125	.8750	.9375	1.0000

decimal point in the numerator, and reduce the fraction thus formed to its lowest terms:

$$0.25 = \frac{25}{100} = \frac{1}{4}; 0.3333 = \frac{3333}{10000} = \frac{1}{3}, \text{ nearly.}$$

**To reduce a recurring decimal to a common fraction.** — Subtract the decimal figures that do not recur from the whole decimal including one set of recurring figures; set down the remainder as the numerator of the fraction, and as many nines as there are recurring figures, followed by as many ciphers as there are non-recurring figures, in the denominator. Thus:

$$\begin{array}{r} \text{Subtract } 0.79054054, \text{ the recurring figures being } 054. \\ \underline{\phantom{0.79054054} 79} \\ 78975 \end{array} = (\text{reduced to its lowest terms}) \frac{117}{148}$$

**COMPOUND OR DENOMINATE NUMBERS.**

**Reduction descending.** — To reduce a compound number to a lower denomination. Multiply the number by as many units of the lower denomination as makes one of the higher.

3 yards to inches:  $3 \times 36 = 108$  inches.

0.04 square feet to square inches:  $.04 \times 144 = 5.76$  sq. in.

If the given number is in more than one denomination proceed in steps from the highest denomination to the next lower, and so on to the lowest, adding in the units of each denomination as the operation proceeds.

3 yds. 1 ft. 7 in. to inches:  $3 \times 3 = 9, +1 = 10, 10 \times 12 = 120, +7 = 127$  in.

**Reduction ascending.** — To express a number of a lower denomination in terms of a higher, divide the number by the number of units of the lower denomination contained in one of the next higher; the quotient is in the higher denomination, and the remainder, if any, in the lower. 127 inches to higher denomination.

$127 \div 12 = 10$  feet + 7 inches;  $10$  feet  $\div 3 = 3$  yards + 1 foot.

Ans. 3 yds. 1 ft. 7 in.

To express the result in decimals of the higher denomination, divide the given number by the number of units of the given denomination contained in one of the required denomination, carrying the result to as many places of decimals as may be desired.

127 inches to yards:  $127 \div 36 = 3\frac{19}{36} = 3.5277 +$  yards.

**Decimals of a Foot Equivalent to Inches and Fractions of an Inch.**

Inches	0	$\frac{1}{8}$	$\frac{1}{4}$	$\frac{3}{8}$	$\frac{1}{2}$	$\frac{5}{8}$	$\frac{3}{4}$	$\frac{7}{8}$
0	0	.01042	.02083	.03125	.04167	.05208	.06250	.07292
1	.0833	.0938	.1042	.1146	.1250	.1354	.1458	.1563
2	.1667	.1771	.1875	.1979	.2083	.2188	.2292	.2396
3	.2500	.2604	.2708	.2813	.2917	.3021	.3125	.3229
4	.3333	.3438	.3542	.3646	.3750	.3854	.3958	.4063
5	.4167	.4271	.4375	.4479	.4583	.4688	.4792	.4896
6	.5000	.5104	.5208	.5313	.5417	.5521	.5625	.5729
7	.5833	.5938	.6042	.6146	.6250	.6354	.6458	.6563
8	.6667	.6771	.6875	.6979	.7083	.7188	.7292	.7396
9	.7500	.7604	.7708	.7813	.7917	.8021	.8125	.8229
10	.8333	.8438	.8542	.8646	.8750	.8854	.8958	.9063
11	.9167	.9271	.9375	.9479	.9583	.9688	.9792	.9896



## RATIO AND PROPORTION.

**Ratio** is the relation of one number to another, as obtained by dividing the first number by the second. Synonymous with quotient.

Ratio of 2 to 4, or  $2 : 4 = \frac{2}{4} = \frac{1}{2}$ .

Ratio of 4 to 2, or  $4 : 2 = 2$ .

**Proportion** is the equality of two ratios. Ratio of 2 to 4 equals ratio of 3 to 6,  $\frac{2}{4} = \frac{3}{6}$ ; expressed thus,  $2 : 4 :: 3 : 6$ ; read, 2 is to 4 as 3 is to 6. The first and fourth terms are called the extremes or outer terms, the second and third the means or inner terms.

The product of the means equals the product of the extremes:

$$2 : 4 :: 3 : 6; \quad 2 \times 6 = 12; \quad 3 \times 4 = 12.$$

Hence, given the first three terms to find the fourth, multiply the second and third terms together and divide by the first.

$$2 : 4 :: 3 : \text{what number?} \quad \text{Ans. } \frac{4 \times 3}{2} = 6.$$

**Algebraic expression of proportion.** —  $a : b :: c : d; \frac{a}{b} = \frac{c}{d}; ad = bc;$

from which  $a = \frac{bc}{d}; d = \frac{bc}{a}; b = \frac{ad}{c}; c = \frac{ad}{b}.$

From the above equations may also be derived the following:

$$\begin{array}{lll} b : a :: d : c & a + b : a :: c + d : c & a + b : a - b :: c + d : c - d \\ a : c :: b : d & a + b : b :: c + d : d & a^n : b^n :: c^n : d^n \\ a : b = c : d & a - b : b :: c - d : d & \sqrt[n]{a} : \sqrt[n]{b} :: \sqrt[n]{c} : \sqrt[n]{d} \\ & a - b : a :: c - d : c & \end{array}$$

**Mean proportional** between two given numbers, 1st and 2d, is such a number that the ratio which the first bears to it equals the ratio which it bears to the second. Thus,  $2 : 4 :: 4 : 8$ ; 4 is a mean proportional between 2 and 8. To find the mean proportional between two numbers, extract the square root of their product.

$$\text{Mean proportional of 2 and 8} = \sqrt{2 \times 8} = 4.$$

**Single Rule of Three;** or, finding the fourth term of a proportion when three terms are given. — Rule, as above, when the terms are stated in their proper order, multiply the second by the third and divide by the first. The difficulty is to state the terms in their proper order. The term which is of the same kind as the required or fourth term is made the third; the first and second must be like each other in kind and denomination. To determine which is to be made second and which first requires a little reasoning. If an inspection of the problem shows that the answer should be greater than the third term, then the greater of the other two given terms should be made the second term — otherwise the first. Thus, 3 men remove 54 cubic feet of rock in a day; how many men will remove in the same time 10 cubic yards? The answer is to be men — make men third term; the answer is to be more than three men, therefore make the greater quantity, 10 cubic yards, the second term; but as it is not the same denomination as the other term it must be reduced, = 270 cubic feet. The proportion is then stated:

$$54 : 270 :: 3 : x \text{ (the required number); } x = \frac{3 \times 270}{54} = 15 \text{ men.}$$

The problem is more complicated if we increase the number of given terms. Thus, in the above question, substitute for the words "in the same time" the words "in 3 days." First solve it as above, as if the work were to be done in the same time; then make another proportion, stating it thus: If 15 men do it in the same time, it will take fewer men to do it in 3 days; make 1 day the second term and 3 days the first term.  $3 : 1 :: 15 \text{ men} : 5 \text{ men.}$



**Compound Proportion, or Double Rule of Three.** — By this rule are solved questions like the one just given, in which two or more statings are required by the single rule of three. In it, as in the single rule, there is one third term, which is of the same kind and denomination as the fourth or required term, but there may be two or more first and second terms. Set down the third term, take each pair of terms of the same kind separately, and arrange them as first and second by the same reasoning as is adopted in the single rule of three, making the greater of the pair the second if this pair considered alone should require the answer to be greater.

Set down all the first terms one under the other, and likewise all the second terms. Multiply all the first terms together and all the second terms together. Multiply the product of all the second terms by the third term, and divide this product by the product of all the first terms. Example: If 3 men remove 4 cubic yards in one day, working 12 hours a day, how many men working 10 hours a day will remove 20 cubic yards in 3 days?

Yards	4 :	20	::	3 men :	x men.
Days	3 :	1 :	::	3 men :	x men.
Hours	10 :	12	::	3 :	6 men.
Products 120 : 240 :: 3 : 6 men. Ans.					

To abbreviate by cancellation, any one of the first terms may cancel either the third or any of the second terms; thus, 3 in first cancels 3 in third, making it 1, 10 cancels into 20 making the latter 2, which into 4 makes it 2, which into 12 makes it 6, and the figures remaining are only 1 : 6 :: 1 : 6.

**INVOLUTION, OR POWERS OF NUMBERS.**

**Involution** is the continued multiplication of a number by itself a given number of times. The number is called the root, or first power, and the products are called powers. The second power is called the square and the third power the cube. The operation may be indicated without being performed by writing a small figure called the *index* or *exponent* to the right of and a little above the root; thus,  $3^3 =$  cube of 3, = 27.

To multiply two or more powers of the same number, add their exponents; thus,  $2^2 \times 2^3 = 2^5$ , or  $4 \times 8 = 32 = 2^5$ .

To divide two powers of the same number, subtract their exponents; thus,  $2^3 \div 2^2 = 2^1 = 2$ ;  $2^2 \div 2^4 = 2^{-2} = \frac{1}{2^2} = \frac{1}{4}$ . The exponent may thus be negative.  $2^3 \div 2^3 = 2^0 = 1$ , whence the zero power of any number = 1. The first power of a number is the number itself. The exponent may be fractional, as  $2^{\frac{1}{2}}$ ,  $2^{\frac{3}{4}}$ , which means that the root is to be raised to a power whose exponent is the numerator of the fraction, and the root whose sign is the denominator is to be extracted (see Evolution). The exponent may be a decimal, as  $2^{0.5}$ ,  $2^{1.5}$ ; read, two to the five-tenths power, two to the one and five-tenths power. These powers are solved by means of Logarithms (which see).

**First Nine Powers of the First Nine Numbers.**

1st Power.	2d Power.	3d Power.	4th Power.	5th Power.	6th Power.	7th Power.	8th Power.	9th Power.
1	1	1	1	1	1	1	1	1
2	4	8	16	32	64	128	256	512
3	9	27	81	243	729	2187	6561	19683
4	16	64	256	1024	4096	16384	65536	262144
5	25	125	625	3125	15625	78125	390625	1953125
6	36	216	1296	7776	46656	279936	1679616	10077696
7	49	343	2401	16807	117649	823543	5764801	40353607
8	64	512	4096	32768	262144	2097152	16777216	134217728
9	81	729	6561	59049	531441	4782969	43046721	387420489

## The First Forty Powers of 2.

Power.	Value.	Power.	Value.	Power.	Value.	Power.	Value.	Power.	Value.
0	1	9	512	18	262144	27	134217728	36	68719476736
1	2	10	1024	19	524288	28	268435456	37	137438953472
2	4	11	2048	20	1048576	29	536870912	38	274877906944
3	8	12	4096	21	2097152	30	1073741824	39	549755813888
4	16	13	8192	22	4194304	31	2147483648	40	1099511627776
5	32	14	16384	23	8388608	32	4294967296		
6	64	15	32768	24	16777216	33	8589934592		
7	128	16	65536	25	33554432	34	17179869184		
8	256	17	131072	26	67108864	35	34359738368		

## EVOLUTION.

**Evolution** is the finding of the root (or extracting the root) of any number the power of which is given.

The sign  $\sqrt{\quad}$  indicates that the square root is to be extracted:  $\sqrt[3]{\quad}$   $\sqrt[4]{\quad}$   $\sqrt[n]{\quad}$ , the cube root, 4th root,  $n$ th root.

A fractional exponent with 1 for the numerator of the fraction is also used to indicate that the operation of extracting the root is to be performed; thus,  $2^{\frac{1}{2}}$ ,  $2^{\frac{3}{4}}$  =  $\sqrt{2}$ ,  $\sqrt[4]{2}$ .

When the power of a number is indicated, the involution not being performed, the extraction of any root of that power may also be indicated by dividing the index of the power by the index of the root, indicating the division by a fraction. Thus, extract the square root of the 6th power of 2:

$$\sqrt{2^6} = 2^{\frac{6}{2}} = 2^3 = 2^3 = 8.$$

The 6th power of 2, as in the table above, is 64;  $\sqrt{64} = 8$ .

Difficult problems in evolution are performed by logarithms, but the square root and the cube root may be extracted directly according to the rules given below. The 4th root is the square root of the square root. The 6th root is the cube root of the square root, or the square root of the cube root; the 9th root is the cube root of the cube root; etc.

**To Extract the Square Root.** — Point off the given number into periods of two places each, beginning with units. If there are decimals, point these off likewise, beginning at the decimal point, and supplying as many ciphers as may be needed. Find the greatest number whose square is less than the first left-hand period, and place it as the first figure in the quotient. Subtract its square from the left-hand period, and to the remainder annex the two figures of the second period for a dividend. Double the first figure of the quotient for a partial divisor; find how many times the latter is contained in the dividend exclusive of the right-hand figure, and set the figure representing that number of times as the second figure in the quotient, and annex it to the right of the partial divisor, forming the complete divisor. Multiply this divisor by the second figure in the quotient and subtract the product from the dividend. To the remainder bring down the next period and proceed as before, in each case doubling the figures in the root already found to obtain the trial divisor. Should the product of the second figure in the root by the completed divisor be greater than the dividend, erase the second figure both from the quotient and from the divisor, and substitute the next smaller figure, or one small enough to make the product of the second figure by the divisor less than or equal to the dividend.

SQUARE ROOT.

$\sqrt{3.1415926536 \overline{1.77245}}$  +  
 1  
 27  $\overline{214}$   
 $\underline{189}$   
 347  $\overline{2515}$   
 $\underline{2429}$   
 3542  $\overline{8692}$   
 $\underline{7084}$   
 35444  $\overline{160865}$   
 $\underline{141776}$   
 354485  $\overline{1908936}$   
 $\underline{1772425}$

CUBE ROOT.

$\sqrt[3]{1,881,365,963,625 \overline{12345}}$   
 1  
 $300 \times 1^2 = 300$  881  
 $30 \times 1 \times 2 = 60$   
 $2^2 = 4$   
 $\underline{364}$  728  
 $300 \times 12^2 = 43200$  153365  
 $30 \times 12 \times 3 = 1080$   
 $3^2 = 9$   
 $\underline{44289}$  132867  
 $300 \times 123^2 = 4538700$  20498963  
 $30 \times 123 \times 4 = 14760$   
 $4^2 = 16$   
 $\underline{4553476}$  18213904  
 $300 \times 1234^2 = 456826800$  2285059625  
 $30 \times 1234 \times 5 = 185100$   
 $5^2 = 25$   
 $\underline{457011925}$  2285059625

To extract the square root of a fraction, extract the root of a numerator and denominator separately.  $\sqrt{\frac{1}{9}} = \frac{1}{3}$ , or first convert the fraction into a decimal,  $\sqrt{\frac{1}{9}} = \sqrt{.4444} = 0.6666 +$ .

**To Extract the Cube Root.** — Point off the number into periods of 3 figures each, beginning at the right hand, or unit's place. Point off decimals in periods of 3 figures from the decimal point. Find the greatest cube that does not exceed the left-hand period; write its root as the first figure in the required root. Subtract the cube from the left-hand period, and to the remainder bring down the next period for a dividend.

Square the first figure of the root; multiply by 300, and divide the product into the dividend for a trial divisor; write the quotient after the first figure of the root as a trial second figure.

Complete the divisor by adding to 300 times the square of the first figure, 30 times the product of the first by the second figure, and the square of the second figure. Multiply this divisor by the second figure; subtract the product from the remainder. (Should the product be greater than the remainder, the last figure of the root and the complete divisor are too large; substitute for the last figure the next smaller number, and correct the trial divisor accordingly.)

To the remainder bring down the next period, and proceed as before to find the third figure of the root — that is, square the two figures of the root already found; multiply by 300 for a trial divisor, etc.

If at any time the trial divisor is greater than the dividend, bring down another period of 3 figures, and place 0 in the root and proceed.

The cube root of a number will contain as many figures as there are periods of 3 in the number.

**To Extract a Higher Root than the Cube.** — The fourth root is the square root of the square root; the sixth root is the cube root of the square root or the square root of the cube root. Other roots are most conveniently found by the use of logarithms.

ALLIGATION.

shows the value of a mixture of different ingredients when the quantity and value of each are known.

Let the ingredients be  $a, b, c, d$ , etc., and their respective values per unit  $w, x, y, z$ , etc.

$A$  = the sum of the quantities =  $a + b + c + d$ , etc.

$P$  = mean value or price per unit of  $A$ .

$AP$  =  $aw + bx + cy + dz$ , etc.

$$P = \frac{aw + bx + cy + dz}{A}.$$

### PERMUTATION

shows in how many positions any number of things may be arranged in a row; thus, the letters  $a, b, c$  may be arranged in six positions, viz.  $abc, acb, cab, cba, bac, bca$ .

Rule. -- Multiply together all the numbers used in counting the things; thus, permutations of 1, 2, and 3 =  $1 \times 2 \times 3 = 6$ . In how many positions can 9 things in a row be placed?

$$1 \times 2 \times 3 \times 4 \times 5 \times 6 \times 7 \times 8 \times 9 = 362880.$$

### COMBINATION

shows how many arrangements of a few things may be made out of a greater number. Rule: Set down that figure which indicates the greater number, and after it a series of figures diminishing by 1, until as many are set down as the number of the few things to be taken in each combination. Then beginning under the last one, set down said number of few things; then going backward set down a series diminishing by 1 until arriving under the first of the upper numbers. Multiply together all the upper numbers to form one product, and all the lower numbers to form another; divide the upper product by the lower one.

How many combinations of 9 things can be made, taking 3 in each combination?

$$\frac{9 \times 8 \times 7}{1 \times 2 \times 3} = \frac{504}{6} = 84.$$

### ARITHMETICAL PROGRESSION,

in a series of numbers, is a progressive increase or decrease in each successive number by the addition or subtraction of the same amount at each step, as 1, 2, 3, 4, 5, etc., or 15, 12, 9, 6, etc. The numbers are called terms, and the equal increase or decrease the difference. Examples in arithmetical progression may be solved by the following formulæ:

Let  $a$  = first term,  $l$  = last term,  $d$  = common difference,  $n$  = number of terms,  $s$  = sum of the terms:

$$\begin{aligned} l &= a + (n - 1)d, & &= -\frac{1}{2}d \pm \sqrt{2ds + \left(a - \frac{1}{2}d\right)^2}, \\ &= \frac{2s}{n} - a, & &= \frac{s}{n} + \frac{(n - 1)d}{2}. \\ s &= \frac{1}{2}n[2a + (n - 1)d], & &= \frac{l + a}{2} + \frac{l^2 - a^2}{2d}, \\ &= (l + a)\frac{n}{2}, & &= \frac{1}{2}n[2l - (n - 1)d]. \\ a &= l - (n - 1)d, & &= \frac{s}{n} - \frac{(n - 1)d}{2}, \\ &= \frac{1}{2}d \pm \sqrt{\left(l + \frac{1}{2}d\right)^2 - 2ds}, & &= \frac{2s}{n} - l. \\ d &= \frac{l - a}{n - 1}, & &= \frac{2(s - an)}{n(n - 1)}, \\ &= \frac{l^2 - a^2}{2s - l - a}, & &= \frac{2(nl - s)}{n(n - 1)}. \\ n &= \frac{l - a}{d} + 1, & &= \frac{d - 2a \pm \sqrt{(2a - d)^2 + 8ds}}{2d}, \\ &= \frac{2s}{l + a}, & &= \frac{2l + d \pm \sqrt{(2l + d)^2 - 8ds}}{2d}. \end{aligned}$$



**GEOMETRICAL PROGRESSION.**

in a series of numbers, is a progressive increase or decrease in each successive number by the same multiplier or divisor at each step, as 1, 2, 4, 8, 16, etc., or 243, 81, 27, 9, etc. The common multiplier is called the ratio.

Let  $a$  = first term,  $l$  = last term,  $r$  = ratio or constant multiplier,  $n$  = number of terms,  $m$  = any term, as 1st, 2d, etc.,  $s$  = sum of the terms:

$$l = ar^{n-1}, \quad = \frac{a + (r-1)s}{r}, \quad = \frac{(r-1)sr^{n-1}}{r^n - 1},$$

$$\log l = \log a + (n-1) \log r, \quad l(s-l)^{n-1} - a(s-a)^{n-1} = 0.$$

$$m = ar^{m-1} \quad \log m = \log a + (m-1) \log r.$$

$$s = \frac{a(r^n - 1)}{r - 1}, \quad = \frac{rl - a}{r - 1}, \quad = \frac{n^{-1}\sqrt[n]{l^n} - n^{-1}\sqrt[n]{a^n}}{n^{-1}\sqrt[n]{l} - n^{-1}\sqrt[n]{a}}, \quad = \frac{lr^n - l}{r^n - r^{n-1}}.$$

$$a = \frac{l}{r^{n-1}}, \quad = \frac{(r-1)s}{r^n - 1}, \quad \log a = \log l - (n-1) \log r.$$

$$r = \sqrt[n]{\frac{l}{a}}, \quad = \frac{s - a}{s - l}, \quad \log r = \frac{\log l - \log a}{n - 1}.$$

$$r^n - \frac{s}{a}r + \frac{s-a}{a} = 0, \quad r^n - \frac{s}{s-l}r^{n-1} + \frac{l}{s-l} = 0.$$

$$n = \frac{\log l - \log a}{\log r} + 1, \quad = \frac{\log [a + (r-1)s] - \log a}{\log r},$$

$$= \frac{\log l - \log a}{\log (s-a) - \log (s-l)} + 1, \quad = \frac{\log l - \log [lr - (r-1)s]}{\log r} + 1.$$

**Population of the United States.**

(A problem in geometrical progression.)

Year.	Population.	Increase in 10 Years, per cent.	Annual Increase, per cent.
1860	31,443,321		
1870	39,818,449*	26.63	2.39
1880	50,155,783	25.96	2.33
1890	62,622,250	24.86	2.25
1900	76,295,220	21.834	1.994
1910	91,972,267	20.53	1.886
1920	Est. 110,367,000	Est. 20.0	Est. 1.840

*Estimated Population in Each Year from 1880 to 1919.*

(Based on the above rates of increase, in even thousands.)

1880.....	50,156	1890....	62,622	1900....	76,295	1910....	91,972
1881.....	51,281	1891....	63,871	1901....	77,734	1911....	93,665
1882.....	52,433	1892....	65,145	1902....	79,201	1912....	95,388
1883.....	53,610	1893....	66,444	1903....	80,695	1913....	97,143
1884.....	54,813	1894....	67,770	1904....	82,217	1914....	98,930
1885.....	56,043	1895....	69,122	1905....	83,768	1915....	100,750
1886.....	57,301	1896....	70,500	1906....	85,348	1916....	102,604
1887.....	58,588	1897....	71,906	1907....	86,958	1917....	104,492
1888.....	59,903	1898....	73,341	1908....	88,598	1918....	106,414
1889.....	61,247	1899....	74,803	1909....	90,269	1919....	108,373

\* Corrected by addition of 1,260,078, estimated error of the census of 1870, Census Bulletin No. 16, Dec. 12, 1890.

The preceding table has been calculated by logarithms as follows:

$\log r = \log l - \log a \div (n - 1),$	$\log m = \log a + (m - 1) \log r$
Pop. 1900... 76,295,220 $\log = 7.8824988$	$= \log l$
“ 1890... 62,622,250 $\log = 7.7967285$	$= \log a$
	diff. = <u>.0857703</u>
$n = 11, n - 1 = 10; \text{diff.} \div 10 =$	$.00857703$
add log for 1890	<u>7.7967285</u>
	log for 1891 = 7.80530553 No. = 63,871 ...
	add again <u>.00857703</u>
	log for 1892 7.81388256 No. = 65,145 ...

**Compound interest** is a form of geometrical progression; the ratio being 1 plus the percentage.

### PERCENTAGE: PROFIT AND LOSS: PER CENT OF EFFICIENCY.

**Per cent** means “by the hundred.” A profit of 10 per cent means a gain of \$10 on every \$100 expended. If a thing is bought for \$1 and sold for \$2 the profit is 100 per cent; but if it is bought for \$2 and sold for \$1 the loss is not 100 per cent, but only 50 per cent.

Rule for percentage: Per cent gain or loss is the gain or loss divided by the original cost, and the quotient multiplied by 100.

**Efficiency** is defined in engineering as the quotient “output divided by input,” that is, the energy utilized divided by the energy expended. The difference between the input and the output is the loss or waste of energy. Expressed as a fraction, efficiency is nearly always less than unity. Expressed as a per cent, it is this fraction multiplied by 100. Thus we may say that a motor has an efficiency of 0.9 or of 90 per cent.

The efficiency of a boiler is the ratio of the heat units absorbed by the boiler in heating water and making steam to the heating value of the coal burned. The saving in fuel due to increasing the efficiency of a boiler from 60 to 75% is not 25%, but only 20%. The rule is: Divide the gain in efficiency (15) by the greater figure (75). The amount of fuel used is inversely proportional to the efficiency; that is, 60 lbs. of fuel with 75% efficiency will do as much work as 75 lbs. with 60% efficiency. The saving of fuel is 15 lbs. which is 20% of 75 lbs.

### INTEREST AND DISCOUNT.

**Interest** is money paid for the use of money for a given time; the factors are:

- $p$ , the sum loaned, or the principal;
- $t$ , the time in years;
- $r$ , the rate of interest;
- $i$ , the amount of interest for the given rate and time;
- $a = p + i =$  the amount of the principal with interest at the end of the time.

Formulae:

$$i = \text{interest} = \text{principal} \times \text{time} \times \text{rate per cent} = i = \frac{ptr}{100};$$

$$a = \text{amount} = \text{principal} + \text{interest} = p + \frac{ptr}{100};$$

$$r = \text{rate} = \frac{100i}{pt};$$

$$p = \text{principal} = \frac{100i}{tr} = a - \frac{ptr}{100};$$

$$t = \text{time} = \frac{100i}{pr}.$$

If the rate is expressed decimally, — thus, 6 per cent = .06, — the formulæ become

$$i = prt; a = p(1 + rt); r = \frac{i}{pt}; t = \frac{i}{pr}; p = \frac{i}{tr} = \frac{a}{1 + rt}.$$

**Rules for finding Interest.** — Multiply the principal by the rate per annum divided by 100, and by the time in years and fractions of a year.

If the time is given in days, interest =  $\frac{\text{principal} \times \text{rate} \times \text{no. of days}}{365 \times 100}$ .

In banks interest is sometimes calculated on the basis of 360 days to a year, or 12 months of 30 days each.

Short rules for interest at 6 per cent, when 360 days are taken as 1 year: Multiply the principal by number of days and divide by 6000.

Multiply the principal by number of months and divide by 200.

The interest of 1 dollar for one month is  $\frac{1}{2}$  cent.

**Interest of 100 Dollars for Different Times and Rates.**

Time	2%	3%	4%	5%	6%	8%	10%
1 year	\$2.00	\$3.00	\$4.00	\$5.00	\$6.00	\$8.00	\$10.00
1 month	.16 $\frac{2}{3}$	.25	.33 $\frac{1}{3}$	.41 $\frac{2}{3}$	.50	.66 $\frac{2}{3}$	.83 $\frac{1}{3}$
1 day = $\frac{1}{360}$ year	.0055 $\frac{5}{8}$	.0083 $\frac{1}{2}$	.0111 $\frac{1}{3}$	.0138 $\frac{2}{3}$	.0166 $\frac{2}{3}$	.0222 $\frac{2}{3}$	.0277 $\frac{1}{3}$
1 day = $\frac{1}{365}$ year	.005479	.008219	.010959	.013699	.016438	.0219178	.0273973

**Discount** is interest deducted for payment of money before it is due.

**True discount** is the difference between the amount of a debt payable at a future date without interest and its present worth. The present worth is that sum which put at interest at the legal rate will amount to the debt when it is due.

To find the present worth of an amount due at a future date, divide the amount by the amount of \$1 placed at interest for the given time. The discount equals the amount minus the present worth.

What discount should be allowed on \$103 paid six months before it is due, interest being 6 per cent per annum?

$$\frac{103}{1 + 1 \times .06 \times \frac{1}{2}} = \$100 \text{ present worth, discount} = 3.00.$$

**Bank discount** is the amount deducted by a bank as interest on money loaned on promissory notes. It is interest calculated not on the actual sum loaned, but on the gross amount of the note, from which the discount is deducted in advance. It is also calculated on the basis of 360 days in the year, and for 3 (in some banks 4) days more than the time specified in the note. These are called days of grace, and the note is not payable till the last of these days. In some States days of grace have been abolished.

What discount will be deducted by a bank in discounting a note for \$103 payable 6 months hence? Six months = 182 days, add 3 days grace = 185 days,  $\frac{103 \times 185}{6000} = \$3.176$ .

**Compound Interest.** — In compound interest the interest is added to the principal at the end of each year, (or shorter period if agreed upon).

Let  $p$  = the principal,  $r$  = the rate expressed decimally,  $n$  = no. of years, and  $a$  the amount:

$$a = \text{amount} = p(1 + r)^n; r = \text{rate} = \sqrt[n]{\frac{a}{p}} - 1.$$

$$p = \text{principal} = \frac{a}{(1 + r)^n}; \text{no. of years} = n = \frac{\log a - \log p}{\log (1 + r)}.$$

## Compound Interest Table.

(Value of one dollar at compound interest, compounded yearly, at 3, 4, 5, and 6 per cent, from 1 to 50 years.)

Years.	Per cent				Years.	Per cent			
	3	4	5	6		3	4	5	6
1	1.03	1.04	1.05	1.06	16	1.6047	1.8730	2.1829	2.5403
2	1.0609	1.0816	1.1025	1.1236	17	1.6528	1.9479	2.2920	2.6928
3	1.0927	1.1249	1.1576	1.1910	18	1.7024	2.0258	2.4066	2.8543
4	1.1255	1.1699	1.2155	1.2625	19	1.7535	2.1068	2.5269	3.0256
5	1.1593	1.2166	1.2763	1.3382	20	1.8061	2.1911	2.6533	3.2071
6	1.1941	1.2653	1.3401	1.4185	21	1.8603	2.2787	2.7859	3.3995
7	1.2299	1.3159	1.4071	1.5036	22	1.9161	2.3699	2.9252	3.6035
8	1.2668	1.3686	1.4774	1.5938	23	1.9736	2.4647	3.0715	3.8197
9	1.3048	1.4233	1.5513	1.6895	24	2.0328	2.5633	3.2251	4.0487
10	1.3439	1.4802	1.6289	1.7908	25	2.0937	2.6658	3.3863	4.2919
11	1.3842	1.5394	1.7103	1.8983	30	2.4272	3.2433	4.3219	5.7435
12	1.4258	1.6010	1.7958	2.0122	35	2.8138	3.9460	5.5159	7.6862
13	1.4685	1.6651	1.8856	2.1329	40	3.2620	4.8009	7.0398	10.2858
14	1.5126	1.7317	1.9799	2.2609	45	3.7815	5.8410	8.9847	13.7648
15	1.5580	1.8009	2.0789	2.3965	50	4.3838	7.1064	11.4670	18.4204

At compound interest at 3 per cent money will double itself in  $23\frac{1}{2}$  years, at 4 per cent in  $17\frac{2}{3}$  years, at 5 per cent in 14.2 years, and at 6 per cent in 11.9 years.

## EQUATION OF PAYMENTS.

By equation of payments we find the equivalent or average time in which one payment should be made to cancel a number of obligations due at different dates; also the number of days upon which to calculate interest or discount upon a gross sum which is composed of several smaller sums payable at different dates.

**Rule.** — Multiply each item by the time of its maturity in days from a fixed date, taken as a standard, and divide the sum of the products by the sum of the items: the result is the average time in days from the standard date.

A owes B \$100 due in 30 days, \$200 due in 60 days, and \$300 due in 90 days. In how many days may the whole be paid in one sum of \$600?

$$100 \times 30 + 200 \times 60 + 300 \times 90 = 42,000; \quad 42,000 \div 600 = 70 \text{ days, } \textit{ans.}$$

A owes B \$100, \$200, and \$300, which amounts are overdue respectively 30, 60, and 90 days. If he now pays the whole amount, \$600, how many days' interest should he pay on that sum? *Ans.* 70 days.

## PARTIAL PAYMENTS.

To compute interest on notes and bonds when partial payments have been made.

**United States Rule.** — Find the amount of the principal to the time of the first payment, and, subtracting the payment from it, find the amount of the remainder as a new principal to the time of the next payment.



If the payment is less than the interest, find the amount of the principal to the time when the sum of the payments equals or exceeds the interest due, and subtract the sum of the payments from this amount.

Proceed in this manner till the time of settlement.

**Note.** — The principles upon which the preceding rule is founded are:

1st. That payments must be applied first to discharge accrued interest, and then the remainder, if any, toward the discharge of the principal.

2d. That only unpaid principal can draw interest.

**Mercantile Method.** — When partial payments are made on short notes or interest accounts, business men commonly employ the following method:

Find the amount of the whole debt to the time of settlement; also find the amount of each payment from the time it was made to the time of settlement. Subtract the amount of payments from the amount of the debt: the remainder will be the balance due.

ANNUITIES.

An **Annuity** is a fixed sum of money paid yearly, or at other equal times agreed upon. The values of annuities are calculated by the principles of compound interest.

1. Let  $i$  denote interest on \$1 for a year, then at the end of a year the amount will be  $1 + i$ . At the end of  $n$  years it will be  $(1 + i)^n$ .

2. The sum which in  $n$  years will amount to 1 is  $\frac{1}{(1 + i)^n}$  or  $(1 + i)^{-n}$ , or the present value of 1 due in  $n$  years.

3. The amount of an annuity of 1 in any number of years  $n$  is  $\frac{(1 + i)^n - 1}{i}$ .

4. The present value of an annuity of 1 for any number of years  $n$  is  $\frac{1 - (1 + i)^{-n}}{i}$ .

5. The annuity which 1 will purchase for any number of years  $n$  is  $\frac{i}{1 - (1 + i)^{-n}}$ .

6. The annuity which would amount to 1 in  $n$  years is  $\frac{i}{(1 + i)^n - 1}$ .

Amounts, Present Values, etc., at 5% Interest.

Years	(1)	(2)	(3)	(4)	(5)	(6)
	$(1 + i)^n$	$(1 + i)^{-n}$	$\frac{(1 + i)^n - 1}{i}$	$\frac{1 - (1 + i)^{-n}}{i}$	$\frac{i}{1 - (1 + i)^{-n}}$	$\frac{i}{(1 + i)^n - 1}$
1 . .	1.05	.952381	1.00	.952381	1.05	1.00
2 . .	1.1025	.907029	2.05	1.859410	.537805	.487805
3 . .	1.157625	.863838	3.1525	2.723248	.367209	.317209
4 . .	1.215506	.822702	4.310125	3.545951	.282012	.232012
5 . .	1.276282	.783526	5.525631	4.329477	.230975	.180975
6 . .	1.340096	.746215	6.801913	5.075692	.197017	.147018
7 . .	1.407100	.710681	8.142008	5.786373	.172820	.122820
8 . .	1.477455	.676839	9.549109	6.463213	.154722	.104722
9 . .	1.551328	.644609	11.026564	7.107822	.140690	.090690
10 . .	1.628895	.613913	12.577893	7.721735	.129505	.079505

## ARITHMETIC.

Table I. — Annuity Required to Redeem \$1000 in from 1 to 50 Years.

Years to run	Rate of Interest, per cent.												
	2	2 1/4	2 1/2	2 3/4	3	3 1/4	3 1/2	3 3/4	4	4 1/2	5	5 1/2	6
2	495.05	494.43	493.83	493.22	492.61	492.00	491.40	490.80	490.20	489.00	487.80	486.62	485.43
3	326.72	325.94	325.14	324.35	323.56	322.75	321.94	321.13	320.36	318.77	317.21	315.63	314.10
4	242.63	241.74	240.84	239.93	239.02	238.14	237.26	236.38	235.50	233.74	232.01	230.29	228.60
5	192.16	191.18	190.24	189.30	188.35	187.42	186.49	185.56	184.63	182.79	180.98	179.13	177.39
6	158.53	157.53	156.56	155.58	154.61	153.64	152.67	151.73	150.79	148.88	147.02	145.18	143.36
7	134.52	133.51	132.49	131.50	130.51	129.54	128.57	127.59	126.61	124.67	122.82	120.96	119.13
8	116.51	115.48	114.47	113.46	112.46	111.47	110.48	109.50	108.53	106.60	104.72	102.86	101.03
9	102.52	101.48	100.46	99.45	98.44	97.44	96.44	95.46	94.49	92.57	90.69	88.83	87.02
10	91.33	90.29	89.25	88.24	87.24	86.24	85.24	84.26	83.29	81.38	79.50	77.67	75.87
11	82.18	81.14	80.11	79.09	78.07	77.08	76.09	75.12	74.15	72.25	70.39	68.57	66.79
12	74.56	73.52	72.49	71.47	70.46	69.47	68.48	67.51	66.55	64.67	62.83	61.03	59.28
13	68.12	67.08	66.05	65.04	64.03	63.05	62.06	61.10	60.14	58.27	56.45	54.68	52.96
14	62.60	61.56	60.54	59.53	58.53	57.55	56.57	55.62	54.67	52.82	51.02	49.28	47.58
15	57.83	56.79	55.77	54.77	53.77	52.79	51.82	50.88	49.94	48.11	46.34	44.62	42.96
16	53.65	52.62	51.60	50.60	49.61	48.64	47.68	46.75	45.82	44.01	42.27	40.58	38.95
17	49.97	48.94	47.93	46.94	45.95	44.99	44.04	43.12	42.20	40.42	38.70	37.04	35.44
18	46.70	45.67	44.67	43.69	42.71	41.76	40.82	39.90	38.99	37.24	35.54	33.92	32.36
19	43.78	42.76	41.76	40.78	39.81	38.87	37.94	37.04	36.14	34.40	32.75	31.15	29.62
20	41.15	40.14	39.14	38.18	37.22	36.29	35.36	34.47	33.58	31.87	30.24	28.68	27.18
25	31.22	30.24	29.27	28.35	27.43	26.55	25.67	24.84	24.01	22.44	20.95	19.55	18.23
30	24.65	23.70	22.78	21.90	21.02	20.19	19.37	18.60	17.83	16.39	15.05	13.80	12.65
35	20.00	19.09	18.20	17.37	16.54	15.77	15.00	14.29	13.58	12.27	11.07	9.97	8.97
40	16.55	15.68	14.84	14.05	13.26	12.54	11.83	11.17	10.52	9.34	8.28	7.32	6.46
45	13.91	13.07	12.27	11.52	10.78	10.12	9.45	8.85	8.26	7.20	6.26	5.43	4.70
50	11.82	11.02	10.26	9.56	8.87	8.25	7.63	7.09	6.55	5.60	4.78	4.06	3.44

**TABLES FOR CALCULATING SINKING-FUNDS AND PRESENT VALUES.**

Engineers and others connected with municipal work and industrial enterprises often find it necessary to calculate payments to sinking-funds which will provide a sum of money sufficient to pay off a bond issue or other debt at the end of a given period, or to determine the present value of certain annual charges. The accompanying tables were computed by Mr. John W. Hill, of Cincinnati, *Eng'g News*, Jan. 25, 1894.

Table I (opposite page) shows the annual sum at various rates of interest required to net \$1000 in from 2 to 50 years, and Table II shows the present value at various rates of interest of an annual charge of \$1000 for from 5 to 50 years, at five-year intervals, and for 100 years.

**Table II. — Capitalization of Annuity of \$1000 for from 5 to 100 Years.**

Years.	Rate of Interest, per cent.							
	2½	3	3½	4	4½	5	5½	6
5	4,645.88	4,579.60	4,514.92	4,451.68	4,389.91	4,329.45	4,268.09	4,212.40
10	8,752.17	8,530.13	8,316.45	8,110.74	7,912.67	7,721.73	7,537.54	7,360.19
15	12,381.41	11,937.80	11,517.23	11,118.06	10,739.42	10,379.53	10,037.48	9,712.30
20	15,589.215	14,877.27	14,212.12	13,590.21	13,007.88	12,462.13	11,950.26	11,469.96
25	18,424.67	17,413.01	16,481.28	15,621.93	14,828.12	14,093.86	13,413.82	12,783.38
30	20,930.59	19,600.21	18,391.85	17,291.86	16,288.77	15,372.36	14,533.63	13,764.85
35	23,145.31	21,487.04	20,000.43	18,664.37	17,460.89	16,374.36	15,390.48	14,488.65
40	25,103.53	23,114.36	21,354.83	19,792.65	18,401.49	17,159.01	16,044.92	15,046.31
45	26,833.15	24,518.49	22,495.23	20,719.89	19,156.24	17,773.99	16,547.65	15,455.85
50	28,362.48	25,729.58	23,455.21	21,482.08	19,761.93	18,255.86	16,931.97	15,761.87
100	36,614.21	31,598.81	27,655.36	24,504.96	21,949.21	19,847.90	18,095.83	16,612.64

**WEIGHTS AND MEASURES.**

**Long Measure. — Measures of Length.**

- 12 inches = 1 foot.
- 3 feet = 1 yard.
- 1760 yards, or 5280 feet = 1 mile.

Additional measures of length in occasional use: 1000 mils = 1 inch; 4 inches = 1 hand; 9 inches = 1 span; 2½ feet = 1 military pace; 2 yards = 1 fathom; 5½ yards, or 16½ feet = 1 rod (formerly also called pole or perch).

**Old Land Measure.** — 7.92 inches = 1 link; 100 links, or 66 feet, or 4 rods = 1 chain; 10 chains, or 220 yards = 1 furlong; 8 furlongs, or 80 chains = 1 mile; 10 square chains = 1 acre.

**Nautical Measure.**

- 6080.26 feet, or 1.15156 statute miles } = 1 nautical mile, or knot.\*
- 3 nautical miles } = 1 league.
- 60 nautical miles, or 69.168 statute miles } = 1 degree (at the equator).
- 360 degrees } = circumference of the earth at the equator.

\* The British Admiralty takes the round figure of 6080 ft. which is the length of the "measured mile" used in trials of vessels. The value varies from 6080.26 to 6088.44 ft. according to different measures of the earth's diameter. There is a difference of opinion among writers as to the use of the word "knot" to mean length or a distance — some holding that it should be used only to denote a rate of speed. The length between knots on the log line is 1/120 of a nautical mile, or 50.7 ft., when a half-minute glass is used; so that a speed of 10 knots is equal to 10 nautical miles per hour.



**Square Measure. — Measures of Surface.**

144 square inches, or 183.35 circular inches	}	= 1 square foot.
9 square feet		= 1 square yard.
30 $\frac{1}{4}$ square yards, or 272 $\frac{1}{4}$ square feet	}	= 1 square rod.
10 sq. chains, or 160 sq. rods, or 4840 sq. yards, or 43560 sq. feet		= 1 acre.
640 acres or 27,878,400 sq. ft.		= 1 square mile.

An acre equals a square whose side is 208.71 feet.

**Circular Inch; Circular Mil.** — A circular inch is the area of a circle 1 inch in diameter = 0.7854 square inch.

1 square inch = 1.2732 circular inches.

A circular mil is the area of a circle 1 mil, or 0.001 inch in diameter. 1000<sup>2</sup> or 1,000,000 circular mils = 1 circular inch.

1 square inch = 1,273,239 circular mils.

The mil and circular mil are used in electrical calculations involving the diameter and area of wires.

**Solid or Cubic Measure. — Measures of Volume.**

1728 cubic inches = 1 cubic foot.

27 cubic feet = 1 cubic yard.

1 cord of wood = a pile, 4 × 4 × 8 feet = 128 cubic feet.

1 perch of masonry = 16 $\frac{1}{2}$  × 1 $\frac{1}{2}$  × 1 foot = 24 $\frac{3}{4}$  cubic feet.

**Liquid Measure.**

4 gills = 1 pint.

2 pints = 1 quart.

4 quarts = 1 gallon { U. S. 231 cubic inches.  
Eng. 277.274 cubic inches.

**Old Liquid Measures.** — 31 $\frac{1}{2}$  gallons = 1 barrel; 42 gallons = 1 tierce; 2 barrels, or 63 gallons = 1 hogshead; 84 gallons, or 2 tierces = 1 puncheon; 2 hogsheads, or 126 gallons = 1 pipe or butt; 2 pipes, or 3 puncheons = 1 tun.

A gallon of water at 62° F. weighs 8.3356 lb. (air free, weighed *in vacuo*).

The U. S. gallon contains 231 cubic inches; 7.4805 gallons = 1 cubic foot. A cylinder 7 in. diam. and 6 in. high contains 1 gallon, very nearly, or 230.9 cubic inches. The British Imperial gallon contains 277.274 cubic inches = 1.20032 U. S. gallon, or 10 lbs. of water at 62° F.

The gallon is a very troublesome unit for engineers. Much labor might be saved if it were abandoned and the cubic foot used instead. The capacity of a tank or reservoir should be stated in cubic feet, and the delivery of a pump in cubic feet per second or in millions of cubic feet in 24 hours. One cubic foot per second = 86,400 cu. ft. in 24 hours. One million cu. ft. per 24 hours = 11.5741 cu. ft. per sec.

**The Miner's Inch.** — (Western U. S. for measuring flow of a stream of water.) An act of the California legislature, May 23, 1901, makes the standard miner's inch 1.5 cu. ft. per minute, measured through any aperture or orifice.

The term Miner's Inch is more or less indefinite, for the reason that California water companies do not all use the same head above the centre of the aperture, and the inch varies from 1.36 to 1.73 cu. ft. per min., but the most common measurement is through an aperture 2 ins. high and whatever length is required, and through a plank 1 $\frac{1}{4}$  ins. thick. The lower edge of the aperture should be 2 ins. above the bottom of the measuring-box, and the plank 5 ins. high above the aperture, thus making a 6-in. head above the centre of the stream. Each square inch of this opening represents a miner's inch, which is equal to a flow of 1 $\frac{1}{2}$  cu. ft. per min.

**Apothecaries' Fluid Measure.**

60 minims = 1 fluid drachm.

8 drachms = 1 fluid ounce.

In the U. S. a fluid ounce is the 128th part of a U. S. gallon, or 1.805 cu. ins. It contains 456.3 grains of water at 39° F. In Great Britain the fluid ounce is 1.732 cu. ins. and contains 1 ounce avoirdupois, or 437.5 grains of water at 62° F.



**Dry Measure, U. S.**

2 pints = 1 quart.      8 quarts = 1 peck.      4 pecks = 1 bushel.

The standard U. S. bushel is the Winchester bushel, which is, in cylinder form, 18½ inches diameter and 8 inches deep, and contains 2150.42 cubic inches.

A struck bushel contains 2150.42 cubic inches = 1.2445 cu. ft.; 1 cubic foot = 0.80356 struck bushel. A heaped bushel is a cylinder 18½ inches diameter and 8 inches deep, with a heaped cone not less than 6 inches high. It is equal to 1¼ struck bushels. (When applied to apples and pears the bushel should be heaped so as to contain 2737.715 cu. in. = 1.2731 struck bushels.—Decision of U. S. Court of Customs Appeals, 1912.)

The British Imperial bushel = 8 imperial gallons or 2218.192 cu. in. = 1.2837 cu. ft. The British quarter = 8 imperial bushels.

Capacity of a cylinder in U. S. gallons = square of diameter, in inches × height in inches × .0034. (Accurate within 1 part in 100,000.)

Capacity of a cylinder in U. S. bushels = square of diameter in inches × height in inches × 0.0003652.

**Shipping Measure.**

*Register Ton.*—For register tonnage or for measurement of the entire internal capacity of a vessel:

100 cubic feet = 1 register ton.

This number is arbitrarily assumed to facilitate computation.

*Shipping Ton.*—For the measurement of cargo:

40 cubic feet = 1 U. S. shipping ton = 32.143 U. S. bushels.

42 cubic feet = 1 British shipping ton = 32.719 imperial bushels.

*Carpenter's Rule.*—Weight a vessel will carry = length of keel × breadth at main beam × depth of hold in feet ÷ 95 (the cubic feet allowed for a ton). The result will be the tonnage. For a double-decker instead of the depth of the hold take half the breadth of the beam.

**Measures of Weight.—Avoirdupois or Commercial Weight.**

16 drachms, or 437.5 grains = 1 ounce, oz.  
 16 ounces, or 7000 grains = 1 pound, lb.  
 28 pounds = 1 quarter, qr.  
 4 quarters = 1 hundredweight, cwt. = 112 lb.  
 20 hundredweight = 1 ton of 2240 lb., gross or long ton.  
 2000 pounds = 1 net, or short ton.  
 2204.6 pounds = 1 metric ton.  
 1 stone = 14 pounds; 1 quintal = 100 pounds.

The drachm, quarter, hundredweight, stone, and quintal are now seldom used in the United States.

**Troy Weight**

24 grains = 1 pennyweight, dwt.  
 20 pennyweights = 1 ounce, oz. = 480 grains.  
 12 ounces = 1 pound, lb. = 5760 grains.

Troy weight is used for weighting gold and silver. The grain is the same in Avoirdupois, Troy, and Apothecaries' weights. A carat, for weighing diamonds = 3.086 grains = 0.200 gramme. (International Standard, 1913.)

**Apothecaries' Weight.**

20 grains = 1 scruple, ℞  
 3 scruples = 1 drachm, ℥ = 60 grains.  
 8 drachms = 1 ounce, ℥ = 480 grains.  
 12 ounces = 1 pound, lb. = 5760 grains.

**To determine whether a balance has unequal arms.** — After weighing an article and obtaining equilibrium, transpose the article and the weights. If the balance is true, it will remain in equilibrium; if untrue, the pan suspended from the longer arm will descend.

**To weigh correctly on an incorrect balance.** — First, by substitution. Put the article to be weighed in one pan of the balance and counterpoise it by any convenient heavy articles placed on the other pan. Remove the article to be weighed and substitute for it standard weights until equipoise is again established. The amount of these weights is the weight of the article.

Second, by transposition. Determine the apparent weight of the article as usual, then its apparent weight after transposing the article and the weights. If the difference is small, add half the difference to the smaller of the apparent weights to obtain the true weight. If the difference is 2 per cent the error of this method is 1 part in 10,000. For larger differences, or to obtain a perfectly accurate result, multiply the two apparent weights together and extract the square root of the product.

#### Circular Measure.

60 seconds,	"	= 1 minute,	'
60 minutes,	'	= 1 degree,	°
90 degrees		= 1 quadrant.	
360	"	= circumference.	

Arc of angle of  $57.3^\circ$ , or  $360^\circ \div 6.2832 = 1$  radian = the arc whose length is equal to the radius.

#### Time.

60 seconds	= 1 minute.
60 minutes	= 1 hour.
24 hours	= 1 day.
7 days	= 1 week.

365 days, 5 hours, 48 minutes, 48 seconds = 1 year.

By the Gregorian Calendar every year whose number is divisible by 4 is a leap year, and contains 366 days, the other years containing 365 days, except that the centesimal years are leap years only when the number of the year is divisible by 400.

The comparative values of mean solar and sidereal time are shown by the following relations according to Bessel:

365.24222 mean solar days	= 366.24222 sidereal days, whence
1 mean solar day	= 1.00273791 sidereal days;
1 sidereal day	= 0.99726957 mean solar day;
24 hours mean solar time	= $24^h 3^m 56^s.555$ sidereal time;
24 hours sidereal time	= $23^h 56^m 4^s.091$ mean solar time,

whence 1 mean solar day is  $3^m 55^s.91$  longer than a sidereal day, reckoned in mean solar time.

### BOARD AND TIMBER MEASURE.

#### Board Measure.

In board measure boards are assumed to be one inch in thickness. To obtain the number of feet board measure (B. M.) of a board or stick of square timber, multiply together the length in feet, the breadth in feet, and the thickness in inches.

**To compute the measure or surface in square feet.** — When all dimensions are in feet, multiply the length by the breadth, and the product will give the surface required.

When either of the dimensions are in inches, multiply as above and divide the product by 12.

When all dimensions are in inches, multiply as before and divide product by 144.

#### Timber Measure.

**To compute the volume of round timber.** — When all dimensions are in feet, multiply the length by one quarter of the product of the mean

girth and diameter, and the product will give the measurement in cubic feet. When length is given in feet, and girth and diameter in inches, divide the product by 144; when all the dimensions are in inches, divide by 1728.

**To compute the volume of square timber.** — When all dimensions are in feet, multiply together the length, breadth, and depth; the product will be the volume in cubic feet. When one dimension is given in inches, divide by 12; when two dimensions are in inches, divide by 144; when all three dimensions are in inches, divide by 1728.

### Contents in Feet of Joists, Scantling, and Timber.

Length in Feet.

Size.	12	14	16	18	20	22	24	26	28	30
Feet Board Measure.										
2 × 4	8	9	11	12	13	15	16	17	19	20
2 × 6	12	14	16	18	20	22	24	26	28	30
2 × 8	16	19	21	24	27	29	32	35	37	40
2 × 10	20	23	27	30	33	37	40	43	47	50
2 × 12	24	28	32	36	40	44	48	52	56	60
2 × 14	28	33	37	42	47	51	56	61	65	70
3 × 8	24	28	32	36	40	44	48	52	56	60
3 × 10	30	35	40	45	50	55	60	65	70	75
3 × 12	36	42	48	54	60	66	72	78	84	90
3 × 14	42	49	56	63	70	77	84	91	98	105
4 × 4	16	19	21	24	27	29	32	35	37	40
4 × 6	24	28	32	36	40	44	48	52	56	60
4 × 8	32	37	43	48	53	59	64	69	75	80
4 × 10	40	47	53	60	67	73	80	87	93	100
4 × 12	48	56	64	72	80	88	96	104	112	120
4 × 14	56	65	75	84	93	103	112	121	131	140
6 × 6	36	42	48	54	60	66	72	78	84	90
6 × 8	48	56	64	72	80	88	96	104	112	120
6 × 10	60	70	80	90	100	110	120	130	140	150
6 × 12	72	84	96	108	120	132	144	156	168	180
6 × 14	84	98	112	126	140	154	168	182	196	210
8 × 8	64	75	85	96	107	117	128	139	149	160
8 × 10	80	93	107	120	133	147	160	173	187	200
8 × 12	96	112	128	144	160	176	192	208	224	240
8 × 14	112	131	149	168	187	205	224	243	261	280
10 × 10	100	117	133	150	167	183	200	217	233	250
10 × 12	120	140	160	180	200	220	240	260	280	300
10 × 14	140	163	187	210	233	257	280	303	327	350
12 × 12	144	168	192	216	240	264	288	312	336	360
12 × 14	168	196	224	252	280	308	336	364	392	420
14 × 14	196	229	261	294	327	359	392	425	457	490

### FRENCH OR METRIC MEASURES.

The metric unit of length is the metre = 39.37 inches.

The metric unit of weight is the gram = 15.432 grains.

The following prefixes are used for subdivisions and multiples: Milli =  $\frac{1}{1000}$ , Centi =  $\frac{1}{100}$ , Deci =  $\frac{1}{10}$ , Deca = 10, Hecto = 100, Kilo = 1000, Myria = 10,000.

## FRENCH AND BRITISH (AND AMERICAN) EQUIVALENT MEASURES.

### Measures of Length.

FRENCH.	BRITISH and U. S.
1 metre	= 39.37 inches, or 3.28083 feet, or 1.09361 yards.
0.3048 metre	= 1 foot.
1 centimetre	= 0.3937 inch.
2.54 centimetres	= 1 inch.
1 millimetre	= 0.03937 inch, or 1/25 inch, nearly.
25.4 millimetres	= 1 inch.
1 kilometre	= 1093.61 yards, or 0.62137 mile.

### Of Surface

FRENCH	BRITISH and U. S.
1 square metre	= { 10.7639 square feet. 1.196 square yards.
0.836 square mètre	= 1 square yard.
0.0929 square metre	= 1 square foot.
1 square centimetre	= 0.15500 square inch.
6.452 square centimetres	= 1 square inch.
1 square millimetre	= 0.00155 sq. in. = 1973.5 circ. mils.
645.2 square millimetres	= 1 square inch.
1 centiare = 1 sq. metre	= 10.764 square feet.
1 are = 1 sq. decametre	= 1076.41 " "
1 hectare = 100 ares	= 107641 " " = 2.4711 acres.
1 sq. kilometre	= 0.386109 sq. miles = 247.11 " "
1 sq. myriametre	= 38.6109 " " "

### Of Volume

FRENCH.	BRITISH and U. S.
1 cubic metre	= { 35.314 cubic feet, 1.308 cubic yards.
0.7645 cubic metre	= 1 cubic yard.
0.02832 cubic metre	= 1 cubic foot.
1 cubic decimetre	= { 61.0234 cubic inches. 0.035314 cubic foot.
28.32 cubic decimetres	= 1 cubic foot.
1 cubic centimetre	= 0.061 cubic inch.
16.387 cubic centimetres	= 1 cubic inch.
1 cubic centimetre = 1 millilitre	= 0.061 cubic inch.
1 decilitre	= 6.102 " " "
1 litre = 1 cubic decimetre	= 61.0234 " " = 1.05671 quarts, U. S.
1 hectolitre or decistere	= 3.5314 cubic feet = 2.8375 bu., U. S.
1 stère, kilolitre, or cubic metre	= 1.308 cubic yards = 28.37 bu., " "

### Of Capacity

FRENCH.	BRITISH and U. S.
1 litre (= 1 cubic decimetre)	= { 61.0234 cubic inches. 0.03531 cubic foot. 0.2642 gallon (American), 2.202 pounds of water at 62° F.
28.317 litres	= 1 cubic foot.
4.543 litres	= 1 gallon (British).
3.785 litres	= 1 gallon (American).

### Of Weight.

FRENCH.	BRITISH and U. S.
1 gramme	= 15,432 grains.
0.0648 gramme	= 1 grain.
1 kilogramme	= 2.204622 pounds.
0.4536 kilogramme	= 1 pound.
1 tonne or metric ton	= { 0.9842 ton of 2240 pounds, 2204.6 pounds.
1000 kilogrammes	= 1 ton of 2240 pounds,
1.016 metric tons	



Mr. O. H. Titmann, in Bulletin No. 9 of the U. S. Coast and Geodetic Survey, discusses the work of various authorities who have compared the yard and the metre, and by referring all the observations to a common standard has succeeded in reconciling the discrepancies within very narrow limits. The following are his results for the number of inches in a metre according to the comparisons of the authorities named: 1817. Hassler, 39.36994 in. 1818. Kater, 39.36990 in. 1835. Baily, 39.36973 in. 1866. Clarke, 39.36970 in. 1885. Comstock, 39.36984 in. The mean of these is 39.36982 in.

The value of the metre is now defined in the U. S. laws as 39.37 inches.

### French and British Equivalents of Compound Units.

FRENCH.	=	BRITISH.
1 gramme per square millimetre	=	1.422 lbs. per sq. in.
1 kilogramme per square " "	=	1422.32 " " " "
1 " " centimetre	=	14.223 " " " "
1.0335 kg. per sq. cm. = 1 atmosphere	=	14.7 " " " "
0.070308 kilogramme per square centimetre	=	1 lb. per square inch.
1 kilogrammetre	=	7.2330 foot-pounds.
1 gramme per litre = 0.062428 lb. per cu. ft.	=	58.349 grains per U. S gal. of water at 62° F.
1 grain per U. S. gallon = 1 part in 58,349	=	1.7138 parts per 100,000
= 0.017138 grammes per litre.		

### METRIC CONVERSION TABLES.

The following tables, with the subjoined memoranda, were published in 1890 by the United States Coast and Geodetic Survey, office of standard weights and measures, T. C. Mendenhall, Superintendent.

#### Tables for Converting U. S. Weights and Measures — Customary to Metric.

##### LINEAR.

	Inches to Milli- metres.	Feet to Metres.	Yards to Metres.	Miles to Kilo- metres.
1 =	25.4001	0.304801	0.914402	1.60935
2 =	50.8001	0.609601	1.828804	3.21869
3 =	76.2002	0.914402	2.743205	4.82804
4 =	101.6002	1.219202	3.657607	6.43739
5 =	127.0003	1.524003	4.572009	8.04674
6 =	152.4003	1.828804	5.486411	9.65608
7 =	177.8004	2.133604	6.400813	11.26543
8 =	203.2004	2.438405	7.315215	12.87478
9 =	228.6005	2.743205	8.229616	14.48412

##### SQUARE.

	Square Inches to Square Centi- metres.	Square Feet to Square Deci- metres.	Square Yards to Square Metres.	Acres to Hectares.
1 =	6.452	9.290	0.836	0.4047
2 =	12.903	18.581	1.672	0.8094
3 =	19.355	27.871	2.508	1.2141
4 =	25.807	37.161	3.344	1.6187
5 =	32.258	46.452	4.181	2.0234
6 =	38.710	55.742	5.017	2.4281
7 =	45.161	65.032	5.853	2.8328
8 =	51.613	74.323	6.689	3.2375
9 =	58.065	83.613	7.525	3.6422

## CUBIC.

	Cubic Inches to Cubic Centi- metres.	Cubic Feet to Cubic Metres.	Cubic Yards to Cubic Metres.	Bushels to Hectolitres.
1 =	16.387	0.02832	0.765	0.35242
2 =	32.774	0.05663	1.529	0.70485
3 =	49.161	0.08495	2.294	1.05727
4 =	65.549	0.11327	3.058	1.40969
5 =	81.936	0.14158	3.823	1.76211
6 =	98.323	0.16990	4.587	2.11454
7 =	114.710	0.19822	5.352	2.46696
8 =	131.097	0.22654	6.116	2.81938
9 =	147.484	0.25485	6.881	3.17181

## CAPACITY.

	Fluid Drachms to Millilitres or Cubic Centi- metres.	Fluid Ounces to Millilitres.	Quarts to Litres.	Gallons to Litres.
1 =	3.70	29.57	0.94636	3.78544
2 =	7.39	59.15	1.89272	7.57088
3 =	11.09	88.72	2.83908	11.35632
4 =	14.79	118.30	3.78544	15.14176
5 =	18.48	147.87	4.73180	18.92720
6 =	22.18	177.44	5.67816	22.71264
7 =	25.88	207.02	6.62452	26.49808
8 =	29.57	236.59	7.57088	30.28352
9 =	33.28	266.16	8.51724	34.06896

## WEIGHT.

	Grains to Milli- grammes.	Avoirdupois Ounces to Grammes.	Avoirdupois Pounds to Kilo- grammes.	Troy Ounces to Grammes.
1 =	64.7989	28.3495	0.45359	31.10348
2 =	129.5978	56.6991	0.90719	62.20696
3 =	194.3968	85.0486	1.36078	93.31044
4 =	259.1957	113.3981	1.81437	124.41392
5 =	323.9946	141.7476	2.26796	155.51740
6 =	388.7935	170.0972	2.72156	186.62089
7 =	453.5924	198.4467	3.17515	217.72437
8 =	518.3914	226.7962	3.62874	248.82785
9 =	583.1903	255.1457	4.08233	279.93133

1 chain = 20.1169 metres.  
 1 square mile = 259 hectares.  
 1 fathom = 1.829 metres.  
 1 nautical mile = 1853.27 metres.  
 1 foot = 0.304801 metre.  
 1 avoirdupois pound = 453.5924277 gram.  
 15432.35639 grains = 1 kilogramme.

Tables for Converting U. S. Weights and Measures—  
Metric to Customary.

## LINEAR.

	Metres to Inches.	Metres to Feet.	Metres to Yards.	Kilometres to Miles.
1 =	39.3700	3.28083	1.093611	0.62137
2 =	78.7400	6.56167	2.187222	1.24274
3 =	118.1100	9.84250	3.280833	1.86411
4 =	157.4800	13.12333	4.374444	2.48548
5 =	196.8500	16.40417	5.468056	3.10685
6 =	236.2200	19.68500	6.561667	3.72822
7 =	275.5900	22.96583	7.655278	4.34959
8 =	314.9600	26.24667	8.748889	4.97096
9 =	354.3300	29.52750	9.842500	5.59233

## SQUARE.

	Square Centi- metres to Square Inches.	Square Metres to Square Feet.	Square Metres to Square Yards.	Hectares to Acres.
1 =	0.1550	10.764	1.196	2.471
2 =	0.3100	21.528	2.392	4.942
3 =	0.4650	32.292	3.588	7.413
4 =	0.6200	43.055	4.784	9.884
5 =	0.7750	53.819	5.980	12.355
6 =	0.9300	64.583	7.176	14.826
7 =	1.0850	75.347	8.372	17.297
8 =	1.2400	86.111	9.568	19.768
9 =	1.3950	96.874	10.764	22.239

## CUBIC.

	Cubic Centi- metres to Cubic Inches.	Cubic Deci- metres to Cubic Inches.	Cubic Metres to Cubic Feet.	Cubic Metres to Cubic Yards.
1 =	0.0610	61.023	35.314	1.308
2 =	0.1220	122.047	70.629	2.616
3 =	0.1831	183.070	105.943	3.924
4 =	0.2441	244.093	141.258	5.232
5 =	0.3051	305.117	176.572	6.540
6 =	0.3661	366.140	211.887	7.848
7 =	0.4272	427.163	247.201	9.156
8 =	0.4882	488.187	282.516	10.464
9 =	0.5492	549.210	317.830	11.771

## CAPACITY.

	Millilitres or Cubic Centi- metres to Fluid Drachms.	Centimetres to Fluid Ounces.	Litres to Quarts.	Dekalitres to Gallons.	Hektolitres to Bushels.
1 =	0.27	0.338	1.0567	2.6417	2.8375
2 =	0.54	0.676	2.1134	5.2834	5.6750
3 =	0.81	1.014	3.1700	7.9251	8.5125
4 =	1.08	1.352	4.2267	10.5668	11.3500
5 =	1.35	1.691	5.2834	13.2085	14.1875
6 =	1.62	2.029	6.3401	15.8502	17.0250
7 =	1.89	2.368	7.3968	18.4919	19.8625
8 =	2.16	2.706	8.4534	21.1336	22.7000
9 =	2.43	3.043	9.5101	23.7753	25.5375

## WEIGHT.

	Milligrammes to Grains.	Kilogrammes to Grains.	Hectogrammes (100 grammes) to Ounces Av.	Kilogrammes to Pounds Avoirdupois.
1 =	0.01543	15432.36	3.5274	2.20462
2 =	0.03086	30864.71	7.0548	4.40924
3 =	0.04630	46297.07	10.5822	6.61386
4 =	0.06173	61729.43	14.1096	8.81849
5 =	0.07716	77161.78	17.6370	11.02311
6 =	0.09259	92594.14	21.1644	13.22773
7 =	0.10803	108026.49	24.6918	15.43235
8 =	0.12346	123458.85	28.2192	17.63697
9 =	0.13889	138891.21	31.7466	19.84159

	Quintals to Pounds Av.	Milliers or Tonnes to Pounds Av.	Grammes to Ounces. Troy.
1 =	220.46	2204.6	0.03215
2 =	440.92	4409.2	0.06430
3 =	661.38	6613.8	0.09645
4 =	881.84	8818.4	0.12860
5 =	1102.30	11023.0	0.16075
6 =	1322.76	13227.6	0.19290
7 =	1543.22	15432.2	0.22505
8 =	1763.68	17636.8	0.25721
9 =	1984.14	19841.4	0.28936

The British Avoirdupois pound was derived from the British standard Troy pound of 1758 by direct comparison, and it contains 7000 grains Troy.

The grain Troy is therefore the same as the grain Avoirdupois, and the pound Avoirdupois in use in the United States is equal to the British pound Avoirdupois.

By the concurrent action of the principal governments of the world an International Bureau of Weights and Measures has been established near Paris.

The International Standard Metre is derived from the Mètre des Archives, and its length is defined by the distance between two lines at 0° Centigrade, on a platinum-iridium bar deposited at the International Bureau.

The International Standard Kilogramme is a mass of platinum-iridium deposited at the same place, and its weight *in vacuo* is the same as that of the Kilogramme des Archives.

Copies of these international standards are deposited in the office of standard weights and measures of the U. S. Coast and Geodetic Survey.

The litre is equal to a cubic decimetre of water, and it is measured by the quantity of distilled water which, at its maximum density, will counterpoise the standard kilogramme in a vacuum; the volume of such a quantity of water being, as nearly as has been ascertained, equal to a cubic decimetre.

The metric system was legalized in the United States in 1866. Many attempts were made during the 40 years following to have the U. S. Congress pass laws to make the metric system the legal standard, but they have all failed. Similar attempts in Great Britain have also failed. For arguments for and against the metric system see the report of a committee of the American Society of Mechanical Engineers, 1903, Vol. 24.



## COMPOUND UNITS.

## Measures of Pressure and Weight.

One pound force (or pressure) = the force exerted by gravity on 1 lb. of matter at a place where the acceleration due to gravity is 32.1740 feet-per-second per second; that is (very nearly) the force of gravity on 1 lb. of matter at latitude 45° at the sea level.

1 lb. per square inch	=	{	144 lb. per square foot.
			2.0355 in. of mercury at 32° F.
			2.0416 " " " " 62° F.
			2.309 ft. of water at 62° F.
			27.71 ins. " " " " 62° F.
1 ounce per sq. in.	=	{	0.1276 in. of mercury at 62° F.
			1.732 in. of water at 62° F.
1 atmosphere (14.7 lb. per sq.in.)	=	{	2116.3 lb. per square foot.
			33.947 ft. of water at 62° F.
			29.921 in. of mercury at 32° F.
			760 millimetres of mercury at 32° F.
1 inch of water at 62° F.	=	{	0.03609 lb. or .5774 oz. per sq. in.
			5.196 lb. per square foot.
			0.0735 in. of mercury at 62° F.
1 foot of water at 62° F.	=	{	0.433 lb. per square inch.
			62.355 lb. per square foot.
1 inch of mercury at 62° F.	=	{	0.491 lb. or 7.86 oz. per sq. in.
			1.134 ft. of water at 62° F.
			13.61 in. of water at 62° F.

## Weight of One Cubic Foot of Pure Water.

At 32° F. (freezing-point) . . . . .	62.418 lb.
" 39.1° F. (maximum density) . . . . .	62.425 "
" 62° F. (standard temperature) <i>in vacuo</i> . . . . .	62.355 "
" 212° F. (boiling-point, under 1 atmosphere) . . . . .	59.76 "
American gallon = 231 cubic ins. of water at 62° F. =	8.3356 lb.
British " = 277.274 " " " " " =	10 lb.
Weight of 1 cu. ft. of air-free distilled water at 62° weighed in air at 62° with brass weights of 8.4 density =	62.287 lb. = 8.3267 lb. per U. S. gallon.

## Weight and Volume of Air.

1 cubic ft. of air at 32° F. and atmospheric pressure weighs	0.080728 lb.
1 ft. in height of air at 32° F. =	{
	0.0005606 lb. per sq. in.
	0.015534 inches of water at 62° F.
For air at any other temperature T° Fahr. multiply by	$492 \div (460 + T)$ .
1 lb. pressure per sq. ft. =	12.387 ft. of air at 32° F.
1 " " " sq. in. =	1784. " " " " "
1 inch of water at 62° F. =	64.37 " " " " "
For air at any other temperature multiply by	$(460 + T) \div 492$ .
At any fixed temperature the weight of a given volume is proportional to the absolute pressure.	

## Measures of Work, Power, and Duty.

**Unit of work.**—One foot-pound, i.e., a pressure of one pound exerted through a space of one foot.

**Horse-power.**—The rate of work. Unit of horse-power = 33,000 ft.-lb. per minute, or 550 ft.-lb. per second = 1,980,000 ft.-lb. per hour.

**Heat unit.** = heat required to raise 1 lb. of water 1° F. (see page 560).

Horse-power expressed in heat-units =  $\frac{33,000}{777.54} = 42.442$  heat-units per minute = 0.7074 heat-unit per second = 2546.5 heat units per hour.

1 lb. of fuel per H.P. per hour = 1,980,000 ft.-lb. per lb. of fuel.

1,000,000 ft.-lb. per lb. of fuel = 1.98 lb. of fuel per H.P. per hour.

**Velocity.**—Feet per second =  $\frac{5280}{3600} = \frac{22}{15}$  × miles per hour.

**Gross tons per mile** =  $\frac{1760}{2240} = \frac{11}{14}$  lb. per yard (single rail).

## WIRE AND SHEET-METAL GAUGES COMPARED.

Number of Gauge.	Birmingham (or Stubs' Iron) Wire Gauge.	American or Brown and Sharpe Gauge.	Roebbling's and Washburn & Moen's Gauge.	Stubs' Steel Wire Gauge. (See also p. 30.)	British Imperial Standard Wire Gauge, 1884.	Brit. St. "B. G." Gauge, 1914, for Iron and Steel Sheets and Hoops.	U. S. Standard Gauge for Sheet and Plate Iron and Steel, 1893.	Number of Gauge.
	inch.	inch.	inch.	inch.	inch.	inch.	inch.	
0000000			.49		.500	.6666	.5	7/0
000000			.46		.464	.625	.469	8/0
00000			.43		.432	.5883	.438	5/0
0000	.454	.46	.393		.4	.5416	.406	4/0
000	.425	.40964	.362		.372	.500	.375	3/0
00	.38	.3648	.331		.348	.4452	.344	2/0
0	.34	.32486	.307		.324	.3964	.313	0
1	.3	.2893	.283	.227	.3	.3532	.281	1
2	.284	.25763	.263	.219	.276	.3147	.266	2
3	.259	.22942	.244	.212	.252	.2804	.25	3
4	.238	.20431	.225	.207	.232	.250	.234	4
5	.22	.18194	.207	.204	.212	.2225	.219	5
6	.203	.16202	.192	.201	.192	.1981	.203	6
7	.18	.14428	.177	.199	.176	.1764	.188	7
8	.165	.12849	.162	.197	.16	.1570	.172	8
9	.148	.11443	.148	.194	.144	.1398	.156	9
10	.134	.10189	.135	.191	.128	.1250	.141	10
11	.12	.09074	.12	.188	.116	.1113	.125	11
12	.109	.08081	.105	.185	.104	.0991	.109	12
13	.095	.07196	.092	.182	.092	.0882	.094	13
14	.083	.06408	.08	.180	.08	.0785	.078	14
15	.072	.05707	.072	.178	.072	.0699	.07	15
16	.065	.05082	.063	.175	.064	.0625	.0625	16
17	.058	.04526	.054	.172	.056	.0556	.0563	17
18	.049	.0403	.047	.168	.048	.0495	.05	18
19	.042	.03589	.041	.164	.04	.0440	.0438	19
20	.035	.03196	.035	.161	.036	.0392	.0375	20
21	.032	.02846	.032	.157	.032	.0349	.0344	21
22	.028	.02535	.028	.155	.028	.03125	.0313	22
23	.025	.02257	.025	.153	.024	.02782	.0281	23
24	.022	.0201	.023	.151	.022	.02476	.025	24
25	.02	.0179	.02	.148	.02	.02204	.0219	25
26	.018	.01594	.018	.146	.018	.01961	.0188	26
27	.016	.01419	.017	.143	.0164	.01745	.0172	27
28	.014	.01264	.016	.139	.0148	.015625	.0156	28
29	.013	.01126	.015	.134	.0136	.0139	.0141	29
30	.012	.01002	.014	.127	.0124	.0123	.0125	30
31	.01	.00893	.013	.120	.0116	.0110	.0109	31
32	.009	.00795	.013	.115	.0108	.0098	.0101	32
33	.008	.00708	.011	.112	.01	.0087	.0094	33
34	.007	.0063	.01	.110	.0092	.0077	.0086	34
35	.005	.00561	.0095	.108	.0084	.0069	.0078	35
36	.004	.005	.009	.106	.0076	.0061	.007	36
37		.00445	.0085	.103	.0068	.0054	.0066	37
38		.00396	.008	.101	.006	.0048	.0063	38
39		.00353	.0075	.099	.0052	.0043		39
40		.00314	.007	.097	.0048	.00386		40
41				.095	.0044	.00343		41
42				.092	.004	.00306		42
43				.088	.0036	.00272		43
44				.085	.0032	.00242		44
45				.081	.0028	.00215		45
46				.079	.0024	.00192		46
47				.077	.002	.00170		47
48				.075	.0016	.00152		48
49				.072	.0012	.00135		49
50				.065	.001	.00120		50

### THE EDISON OR CIRCULAR MIL WIRE GAUGE.

(For table of copper wires by this gauge, giving weights, electrical resistances, etc., see Copper Wire.)

Mr. C. J. Field (*Stevens Indicator*, July, 1887) thus describes the origin of the Edison gauge:

The Edison company experienced inconvenience and loss by not having a wide enough range nor sufficient number of sizes in the existing gauges. This was felt more particularly in the central-station work in making electrical determinations for the street system. They were compelled to make use of two of the existing gauges at least, thereby introducing a complication that was liable to lead to mistakes by the contractors and linemen.

In the incandescent system an even distribution throughout the entire system and a uniform pressure at the point of delivery are obtained by calculating for a given maximum percentage of loss from the potential as delivered from the dynamo. In carrying this out, on account of lack of regular sizes, it was often necessary to use larger sizes than the occasion demanded, and even to assume new sizes for large underground conductors. The engineering department of the Edison company, knowing the requirements, have designed a gauge that has the widest range obtainable and a large number of sizes which increase in a regular and uniform manner. The basis of the graduation is the sectional area, and the number of the wire corresponds. A wire of 100,000 circular mils area is No. 100; a wire of one half the size will be No. 50; twice the size No. 200.

In the older gauges, as the number increased the size decreased. With this gauge, however, the number increases with the wire, and the number multiplied by 1000 will give the circular mils.

The weight per mil-foot, 0.0000302705 pounds, agrees with a specific gravity of 8.889, which is the latest figure given for copper. The ampere capacity which is given was deduced from experiments made in the company's laboratory, and is based on a rise of temperature of 50° F. in the wire.

In 1893 Mr. Field writes, concerning gauges in use by electrical engineers:

The B. and S. gauge seems to be in general use for the smaller sizes, up to 100,000 c.m., and in some cases a little larger. From between one and two hundred thousand circular mils upwards, the Edison gauge or its equivalent is practically in use, and there is a general tendency to designate all sizes above this in circular mils, specifying a wire as 200,000, 400,000, 500,000, or 1,000,000 C.M.

In the electrical business there is a large use of copper wire and rod and other materials of these large sizes, and in ordering them, speaking of them, specifying, and in every other use, the general method is to simply specify the circular milage. I think it is going to be the only system in the future for the designation of wires, and the attaining of it means practically the adoption of the Edison gauge or the method and basis of this gauge as the correct one for wire sizes.

### THE U. S. STANDARD GAUGE FOR SHEET AND PLATE IRON AND STEEL, 1893.

There is in this country no uniform or standard gauge, and the same numbers in different gauges represent different thicknesses of sheets or plates. This has given rise to much misunderstanding and friction between employers and workmen and mistakes and fraud between dealers and consumers.

An Act of Congress in 1893 established the Standard Gauge for sheet iron and steel which is given on the next page. It is based on the fact that a cubic foot of iron weighs 480 pounds.

A sheet of iron 1 foot square and 1 inch thick weighs 40 pounds, or 640 ounces, and 1 ounce in weight should be  $\frac{1}{640}$  inch thick. The scale has been arranged so that each descriptive number represents a certain number of ounces in weight and an equal number of 640ths of an inch in thickness.

The law enacts that on and after July 1, 1893, the new gauge shall be used in determining duties and taxes levied on sheet and plate iron and

(Continued on page 32.)



## Edison, or Circular Mil Gauge for Electrical Wires.

Gauge Number.	Circular Mils.	Diameter in Mils.	Gauge Number.	Circular Mils.	Diameter in Mils.	Gauge Number.	Circular Mils.	Diameter in Mils.
3	3,000	54.78	70	70,000	264.58	190	190,000	435.89
5	5,000	70.72	75	75,000	273.87	200	200,000	447.22
8	8,000	89.45	80	80,000	282.85	220	220,000	469.05
12	12,000	109.55	85	85,000	291.55	240	240,000	489.90
15	15,000	122.48	90	90,000	300.00	260	260,000	509.91
20	20,000	141.43	95	95,000	308.23	280	280,000	529.16
25	25,000	158.12	100	100,000	316.23	300	300,000	547.73
30	30,000	173.21	110	110,000	331.67	320	320,000	565.69
35	35,000	187.09	120	120,000	346.42	340	340,000	583.10
40	40,000	200.00	130	130,000	360.56	360	360,000	600.00
45	45,000	212.14	140	140,000	374.17			
50	50,000	223.61	150	150,000	387.30			
55	55,000	234.53	160	160,000	400.00			
60	60,000	244.95	170	170,000	412.32			
65	65,000	254.96	180	180,000	424.27			

Twist Drill and Steel Wire Gauge.  
(Manufacturers Standard)

No.	Size.	No.	Size.	No.	Size.	No.	Size.	No.	Size.	No.	Size.
	inch.		inch.		inch.		inch.		inch.		inch.
1	0.2280	14	0.1820	27	0.1440	40	0.0980	53	0.0595	67	0.0320
2	.2210	15	.1800	28	.1405	41	.0960	54	.0550	68	.0310
3	.2130	16	.1770	29	.1360	42	.0935	55	.0520	69	.0292
4	.2090	17	.1730	30	.1285	43	.0890	56	.0465	70	.0280
5	.2055	18	.1695	31	.1200	44	.0860	57	.0430	71	.0260
6	.2040	19	.1660	32	.1160	45	.0820	58	.0420	72	.0250
7	.2010	20	.1610	33	.1130	46	.0810	59	.0410	73	.0240
8	.1990	21	.1590	34	.1110	47	.0785	60	.0400	74	.0225
9	.1960	22	.1570	35	.1100	48	.0760	61	.0390	75	.0210
10	.1935	23	.1540	36	.1065	49	.0730	62	.0380	76	.0200
11	.1910	24	.1520	37	.1040	50	.0700	63	.0370	77	.0180
12	.1890	25	.1495	38	.1015	51	.0670	64	.0360	78	.0160
13	.1850	26	.1470	39	.0995	52	.0635	65	.0350	79	.0145
								66	.0330	80	.0135

## Stubs' Steel Wire Gauge.

(For Nos. 1 to 50 see table on page 31.)

No.	Size.	No.	Size.	No.	Size.	No.	Size.	No.	Size.	No.	Size.
	inch.		inch.		inch.		inch.		inch.		inch.
Z	.413	P	.323	F	.257	51	.066	61	.038	71	.026
Y	.404	O	.316	E	.250	52	.063	62	.037	72	.024
X	.397	N	.302	D	.246	53	.058	63	.036	73	.023
W	.386	M	.295	C	.242	54	.055	64	.035	74	.022
V	.377	L	.290	B	.238	55	.050	65	.033	75	.020
U	.368	K	.281	A	.234	56	.045	66	.032	76	.018
T	.358	J	.277	I		57	.042	67	.031	77	.016
S	.348	I	.272	to		58	.041	68	.030	78	.015
R	.339	H	.266	50		59	.040	69	.029	79	.014
Q	.332	G	.261			60	.039	70	.027	80	.013

The Stubs' Steel Wire Gauge is used in measuring drawn steel wire or drill rods of Stubs' make, and is also used by many makers of American drill rods.



U. S. STANDARD GAUGE FOR SHEET AND PLATE  
IRON AND STEEL, 1893.

Number of Gauge.	Approximate Thickness in Fractions of an Inch.	Approximate Thickness in Decimal Parts of an Inch.	Approximate Thickness in Millimeters.	Weight per Square Foot in Ounces Avoirdupois.	Weight per Square Foot in Pounds Avoirdupois.	Weight per Square Foot in Kilograms.	Weight per Square Meter in Kilograms.	Weight per Sq. Meter in Pounds Avoirdupois.
0000000	1-2	0.5	12.7	320	20.	9.072	97.65	215.28
000000	15-32	0.46875	11.90625	300	18.75	8.505	91.55	201.82
00000	7-16	0.4375	11.1125	280	17.50	7.938	85.44	188.37
0000	13-32	0.40625	10.31875	260	16.25	7.371	79.33	174.91
000	3-8	0.375	9.525	240	15.	6.804	73.24	161.46
00	11-32	0.34375	8.73125	220	13.75	6.237	67.13	148.00
0	5-16	0.3125	7.9375	200	12.50	5.67	61.03	134.55
1	9-32	0.28125	7.14375	180	11.25	5.103	54.93	121.09
2	17-64	0.265625	6.746875	170	10.625	4.819	51.88	114.37
3	1-4	0.25	6.35	160	10.	4.536	48.82	107.64
4	15-64	0.234375	5.953125	150	9.375	4.252	45.77	100.91
5	7-32	0.21875	5.55625	140	8.75	3.969	42.72	94.18
6	13-64	0.203125	5.159375	130	8.125	3.685	39.67	87.45
7	3-16	0.1875	4.7625	120	7.5	3.402	36.62	80.72
8	11-64	0.171875	4.365625	110	6.875	3.118	33.57	74.00
9	5-32	0.15625	3.96875	100	6.25	2.835	30.52	67.27
10	9-64	0.140625	3.571875	90	5.625	2.552	27.46	60.55
11	1-8	0.125	3.175	80	5.	2.268	24.41	53.82
12	7-64	0.109375	2.778125	70	4.375	1.984	21.36	47.09
13	3-32	0.09375	2.38125	60	3.75	1.701	18.31	40.36
14	5-64	0.078125	1.984375	50	3.125	1.417	15.26	33.64
15	9-128	0.0703125	1.7859375	45	2.8125	1.276	13.73	30.27
16	1-16	0.0625	1.5875	40	2.5	1.134	12.21	26.91
17	9-160	0.05625	1.42875	36	2.25	1.021	10.99	24.22
18	1-20	0.05	1.27	32	2.	0.9072	9.765	21.53
19	7-160	0.04375	1.11125	28	1.75	0.7938	8.544	18.84
20	3-80	0.0375	0.9525	24	1.50	0.6804	7.324	16.15
21	11-320	0.034375	0.873125	22	1.375	0.6237	6.713	14.80
22	1-32	0.03125	0.793750	20	1.25	0.567	6.103	13.46
23	9-320	0.028125	0.714375	18	1.125	0.5103	5.49	12.11
24	1-40	0.025	0.635	16	1.	0.4536	4.882	10.76
25	7-320	0.021875	0.555625	14	0.875	0.3969	4.272	9.42
26	3-160	0.01875	0.47625	12	0.75	0.3402	3.662	8.07
27	11-640	0.0171875	0.4365625	11	0.6875	0.3119	3.357	7.40
28	1-64	0.015625	0.396875	10	0.625	0.2835	3.052	6.73
29	9-640	0.0140625	0.3571875	9	0.5625	0.2551	2.746	6.05
30	1-80	0.0125	0.3175	8	0.5	0.2268	2.441	5.38
31	7-640	0.0109375	0.2778125	7	0.4375	0.1984	2.136	4.71
32	13-1280	0.01015625	0.25796875	6 1/2	0.40625	0.1843	1.983	4.37
33	3-320	0.009375	0.238125	6	0.375	0.1701	1.831	4.04
34	11-1280	0.00859375	0.21828125	5 1/2	0.34375	0.1559	1.678	3.70
35	5-640	0.0078125	0.1984375	5	0.3125	0.1417	1.526	3.36
36	9-1280	0.00703125	0.17859375	4 1/2	0.28125	0.1276	1.373	3.03
37	17-2560	0.00664062	0.16867187	4 1/4	0.26562	0.1205	1.297	2.87
38	1-160	0.00625	0.15875	4	0.25	0.1134	1.221	2.69

(continued from page 29) steel; and that in its application a variation of 2 1/2 per cent either way may be allowed.

**The Decimal Gauge.** — The legalization of the standard sheet-metal gauge of 1893 and its adoption by some manufacturers of sheet iron have only added to the existing confusion of gauges. A joint committee of the American Society of Mechanical Engineers and the American Railway Master Mechanics' Association in 1895 agreed to recommend the use of the decimal gauge, that is, a gauge whose number for each thickness is the number of thousandths of an inch in that thickness, and also to recommend "the abandonment and disuse of the various other gauges now in use, as tending to confusion and error." A notched gauge of oval form, shown in the cut below, has come into use as a standard form of the decimal gauge.

In 1904 The Westinghouse Electric & Mfg. Co. abandoned the use of gauge numbers in referring to wire, sheet metal, etc.

**Weight of Sheet Iron and Steel. Thickness by Decimal Gauge.**

Decimal Gauge.	Approx. Fractions of an Inch.	Approx. Millimeters.	Weight per Square Foot in Pounds.		Decimal Gauge.	Approx. Fractions of an Inch.	Approx. Millimeters.	Weight per Square Foot in Pounds.	
			Iron, 480 Lbs. per Cu. Ft.	Steel, 489.6 Lbs. per Cu. Ft.				Iron, 480 Lbs. per Cu. Ft.	Steel, 489.6 Lbs. per Cu. Ft.
0.002	1/500	0.05	0.08	0.082	0.060	1/16	1.52	2.40	2.448
0.004	1/250	0.10	0.16	0.163	0.065	13/200	1.65	2.60	2.652
0.006	3/500	0.15	0.24	0.245	0.070	7/100	1.78	2.80	2.856
0.008	1/125	0.20	0.32	0.326	0.075	3/40	1.90	3.00	3.060
0.010	1/100	0.25	0.40	0.408	0.080	2/25	2.03	3.20	3.264
0.012	3/250	0.30	0.48	0.490	0.085	17/200	2.16	3.40	3.468
0.014	7/500	0.36	0.56	0.571	0.090	9/100	2.28	3.60	3.672
0.016	1/64 +	0.41	0.64	0.653	0.095	19/200	2.41	3.80	3.876
0.018	9/500	0.46	0.72	0.734	0.100	1/10	2.54	4.00	4.080
0.020	1/50	0.51	0.80	0.816	0.110	11/100	2.79	4.40	4.488
0.022	11/500	0.56	0.88	0.898	0.125	1/8	3.18	5.00	5.100
0.025	1/40	0.64	1.00	1.020	0.135	27/200	3.43	5.40	5.508
0.028	7/250	0.71	1.12	1.142	0.150	3/20	3.81	6.00	6.120
0.032	1/32 +	0.81	1.28	1.306	0.165	33/200	4.19	6.60	6.732
0.036	9/250	0.91	1.44	1.469	0.180	9/50	4.57	7.20	7.344
0.040	1/25	1.02	1.60	1.632	0.200	1/5	5.08	8.00	8.160
0.045	9/200	1.14	1.80	1.836	0.220	11/50	5.59	8.80	8.976
0.050	1/20	1.27	2.00	2.040	0.240	6/25	6.10	9.60	9.792
0.055	11/200	1.40	2.20	2.244	0.250	1/4	6.35	10.00	10.200

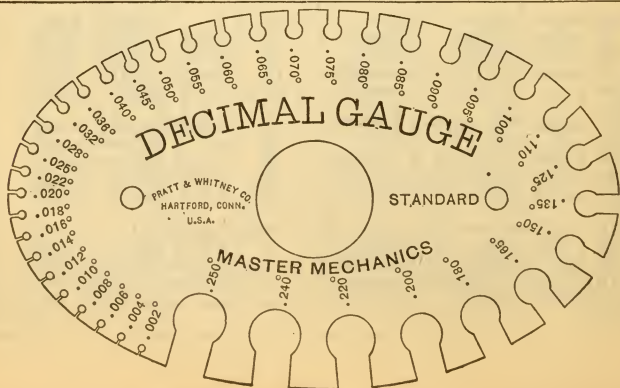

## ALGEBRA.

**Addition.** — Add  $a$ ,  $b$ , and  $-c$ . Ans.  $a + b - c$ .

Add  $2a$  and  $-3a$ . Ans.  $-a$ . Add  $2ab$ ,  $-3ab$ ,  $-c$ ,  $-3c$ . Ans.  $-ab - 4c$ . Add  $a^2$  and  $2a$ . Ans.  $a^2 + 2a$ .

**Subtraction.** — Subtract  $a$  from  $b$ . Ans.  $b - a$ . Subtract  $-a$  from  $-b$ . Ans.  $-b + a$ .

Subtract  $b + c$  from  $a$ . Ans.  $a - b - c$ . Subtract  $3a^2b - 9c$  from  $4a^2b + c$ . Ans.  $a^2b + 10c$ . RULE: Change the signs of the subtrahend and proceed as in addition.

**Multiplication.** — Multiply  $a$  by  $b$ . Ans.  $ab$ . Multiply  $ab$  by  $a + b$ . Ans.  $a^2b + ab^2$ .

Multiply  $a + b$  by  $a + b$ . Ans.  $(a + b)(a + b) = a^2 + 2ab + b^2$ .

Multiply  $-a$  by  $-b$ . Ans.  $ab$ . Multiply  $-a$  by  $b$ . Ans.  $-ab$ . Like signs give plus, unlike signs minus.

**Powers of numbers.** — The product of two or more powers of any number is the number with an exponent equal to the sum of the powers:  $a^2 \times a^3 = a^5$ ;  $a^2b^2 \times ab = a^3b^3$ ;  $-7ab \times 2ac = -14a^2bc$ .

To multiply a polynomial by a monomial, multiply each term of the polynomial by the monomial and add the partial products:  $(6a - 3b) \times 3c = 18ac - 9bc$ .

To multiply two polynomials, multiply each term of one factor by each term of the other and add the partial products:  $(5a - 6b) \times (3a - 4b) = 15a^2 - 38ab + 24b^2$ .

The square of the sum of two numbers = sum of their squares + twice their product.

The square of the difference of two numbers = the sum of their squares - twice their product.

The product of the sum and difference of two numbers = the difference of their squares:

$$(a + b)^2 = a^2 + 2ab + b^2; (a - b)^2 = a^2 - 2ab + b^2;$$

$$(a + b) \times (a - b) = a^2 - b^2.$$

The square of half the sums of two quantities is equal to their product plus the square of half their difference:  $\left(\frac{a+b}{2}\right)^2 = ab + \left(\frac{a-b}{2}\right)^2$ .

The square of the sum of two quantities is equal to four times their products, plus the square of their difference:  $(a + b)^2 = 4ab + (a - b)^2$ .

The sum of the squares of two quantities equals twice their product, plus the square of their difference:  $a^2 + b^2 = 2ab + (a - b)^2$ .

The square of a trinomial = square of each term + twice the product of each term by each of the terms that follow it:  $(a + b + c)^2 = a^2 + b^2 + c^2 + 2ab + 2ac + 2bc$ ;  $(a - b - c)^2 = a^2 + b^2 + c^2 - 2ab - 2ac + 2bc$ .

The square of (any number +  $\frac{1}{2}$ ) = square of the number + the number +  $\frac{1}{4}$ ; = the number  $\times$  (the number + 1) +  $\frac{1}{4}$ ;  $(a + \frac{1}{2})^2 = a^2 + a + \frac{1}{4}$ , =  $a(a + 1) + \frac{1}{4}$ .  $(4\frac{1}{2})^2 = 4^2 + 4 + \frac{1}{4} = 4 \times 5 + \frac{1}{4} = 20\frac{1}{4}$ .

The product of any number +  $\frac{1}{2}$  by any other number +  $\frac{1}{2}$  = product of the numbers + half their sum +  $\frac{1}{4}$ .  $(a + \frac{1}{2}) \times (b + \frac{1}{2}) = ab + \frac{1}{2}(a + b) + \frac{1}{4}$ .  $4\frac{1}{2} \times 6\frac{1}{2} = 4 \times 6 + \frac{1}{2}(4 + 6) + \frac{1}{4} = 24 + 5 + \frac{1}{4} = 29\frac{1}{4}$ .

**Square, cube, 4th power, etc., of a binomial  $a + b$ .**

$$(a + b)^2 = a^2 + 2ab + b^2; (a + b)^3 = a^3 + 3a^2b + 3ab^2 + b^3$$

$$(a + b)^4 = a^4 + 4a^3b + 6a^2b^2 + 4ab^3 + b^4.$$

In each case the number of terms is one greater than the exponent of the power to which the binomial is raised.

2. In the first term the exponent of  $a$  is the same as the exponent of the power to which the binomial is raised, and it decreases by 1 in each succeeding term.

3.  $b$  appears in the second term with the exponent 1, and its exponent increases by 1 in each succeeding term.

4. The coefficient of the first term is 1.

5. The coefficient of the second term is the exponent of the power to which the binomial is raised.

6. The coefficient of each succeeding term is found from the next preceding term by multiplying its coefficient by the exponent of  $a$ , and dividing the product by a number greater by 1 than the exponent of  $b$ . (See Binomial Theorem, below.)

**Parentheses.** — When a parenthesis is preceded by a plus sign it may be removed without changing the value of the expression:  $a + b + (a + b) = a + b + 2b$ . When a parenthesis is preceded by a minus sign it may be removed if we change the signs of all the terms within the parenthesis:  $1 - (a - b - c) = 1 - a + b + c$ . When a parenthesis is within a parenthesis remove the inner one first:  $a - [b - \{c - (d - e)\}] = a - [b - \{c - d + e\}] = a - [b - c + d - e] = a - b + c - d + e$ .

A multiplication sign,  $\times$ , has the effect of a parenthesis, in that the operation indicated by it must be performed before the operations of addition or subtraction.  $a + b \times a + b = a + ab + b$ ; while  $(a + b) \times (a + b) = a^2 + 2ab + b^2$ , and  $(a + b) \times a + b = a^2 + ab + b$ .

The absence of any sign between two parentheses, or between a quantity and a parenthesis, indicates that the parenthesis is to be multiplied by the quantity or parenthesis:  $a(a + b + c) = a^2 + ab + ac$ .

**Division.** — The quotient is positive when the dividend and divisor have like signs, and negative when they have unlike signs:  $abc \div b = ac$ ;  $abc \div -b = -ac$ .

To divide a monomial by a monomial, write the dividend over the divisor with a line between them. If the expressions have common factors, remove the common factors:

$$a^2bx \div aby = \frac{a^2bx}{aby} = \frac{ax}{y}; \quad \frac{a^4}{a^3} = a; \quad \frac{a^3}{a^5} = \frac{1}{a^2} = a^{-2}.$$

To divide a polynomial by a monomial, divide each term of the polynomial by the monomial:  $(8ab - 12ac) \div 4a = 2b - 3c$ .

To divide a polynomial by a polynomial, arrange both dividend and divisor in the order of the ascending or descending powers of some common letter, and keep this arrangement throughout the operation.

Divide the first term of the dividend by the first term of the divisor, and write the result as the first term of the quotient.

Multiply all the terms of the divisor by the first term of the quotient and subtract the product from the dividend. If there be a remainder, consider it as a new dividend and proceed as before:  $(a^2 - b^2) \div (a + b)$ .

$$\begin{array}{r} a^2 - b^2 \quad | \quad a + b. \\ a^2 + ab \quad | \quad a - b. \\ \hline - ab - b^2. \\ \hline - ab - b^2. \end{array}$$

The difference of two equal odd powers of any two numbers is divisible by their difference but not by their sum:

$$(a^3 - b^3) \div (a - b) = a^2 + ab + b^2; \quad (a^3 - b^3) \div (a + b) = a^2 - ab - b^2 + \dots$$

The difference of two equal even powers of two numbers is divisible by their difference and also by their sum:  $(a^2 - b^2) \div (a - b) = a + b$ .

The sum of two equal even powers of two numbers is not divisible by either the difference or the sum of the numbers; but when the exponent of each of the two equal powers is composed of an odd and an even factor, the sum of the given power is divisible by the sum of the powers expressed by the even factor. Thus  $x^6 + y^6$  is not divisible by  $x + y$  or by  $x - y$ , but is divisible by  $x^2 + y^2$ .

**Simple equations.** — An equation is a statement of equality between two expressions; as,  $a + b = c + d$ .

A simple equation, or equation of the first degree, is one which contains only the first power of the unknown quantity. If equal changes be made (by addition, subtraction, multiplication, or division) in both sides of an equation, the results will be equal.

Any term may be changed from one side of an equation to another, provided its sign be changed:  $a + b = c + d$ ;  $a = c + d - b$ . To solve



an equation having one unknown quantity, transpose all the terms involving the unknown quantity to one side of the equation, and all the other terms to the other side; combine like terms, and divide both sides by the coefficient of the unknown quantity.

Solve  $8x - 29 = 26 - 3x$ .  $8x + 3x = 29 + 26$ ;  $11x = 55$ ;  $x = 5$ , ans.

Simple algebraic problems containing one unknown quantity are solved by making  $x$  = the unknown quantity, and stating the conditions of the problem in the form of an algebraic equation, and then solving the equation. What two numbers are those whose sum is 48 and difference 14? Let  $x$  = the smaller number,  $x + 14$  the greater.  $x + x + 14 = 48$ .  $2x = 34$ ,  $x = 17$ ;  $x + 14 = 31$ , ans.

Find a number whose treble exceeds 50 as much as its double falls short of 40. Let  $x$  = the number.  $3x - 50 = 40 - 2x$ ;  $5x = 90$ ;  $x = 18$ , ans. Proving,  $54 - 50 = 40 - 36$ .

**Equations containing two unknown quantities.** — If one equation contains two unknown quantities,  $x$  and  $y$ , an indefinite number of pairs of values of  $x$  and  $y$  may be found that will satisfy the equation, but if a second equation be given only one pair of values can be found that will satisfy both equations. Simultaneous equations, or those that may be satisfied by the same values of the unknown quantities, are solved by combining the equations so as to obtain a single equation containing only one unknown quantity. This process is called elimination.

*Elimination by addition or subtraction.* — Multiply the equation by such numbers as will make the coefficients of one of the unknown quantities equal in the resulting equation. Add or subtract the resulting equations according as they have unlike or like signs.

$$\text{Solve } \begin{cases} 2x + 3y = 7. \\ 4x - 5y = 3. \end{cases} \quad \begin{array}{l} \text{Multiply by 2:} \\ \text{Subtract:} \end{array} \quad \begin{array}{l} 4x + 6y = 14 \\ \underline{4x - 5y = 3} \\ 11y - 11; y = 1. \end{array}$$

Substituting value of  $y$  in first equation,  $2x + 3 = 7$ ;  $x = 2$ .

*Elimination by substitution.* — From one of the equations obtain the value of one of the unknown quantities in terms of the other. Substitute for this unknown quantity its value in the other equation and reduce the resulting equations.

$$\text{Solve } \begin{cases} 2x + 3y = 8. & (1). \\ 3x + 7y = 7. & (2). \end{cases} \quad \text{From (1) we find } x = \frac{8 - 3y}{2}.$$

$$\text{Substitute this value in (2): } 3 \left( \frac{8 - 3y}{2} \right) + 7y = 7; = 24 - 9y + 14y = 14,$$

whence  $y = -2$ . Substitute this value in (1):  $2x - 6 = 8$ ;  $x = 7$ .

*Elimination by comparison.* — From each equation obtain the value of one of the unknown quantities in terms of the other. Form an equation from these equal values, and reduce this equation.

$$\text{Solve } 2x - 9y = 11. \quad (1) \quad \text{and } 3x - 4y = 7. \quad (2). \quad \text{From (1) we find } x = \frac{11 + 9y}{2}. \quad \text{From (2) we find } x = \frac{7 + 4y}{3}.$$

$$\text{Equating these values of } x, \frac{11 + 9y}{2} = \frac{7 + 4y}{3}; 19y = -19; y = -1.$$

Substitute this value of  $y$  in (1):  $2x + 9 = 11$ ;  $x = 1$ .

If three simultaneous equations are given containing three unknown quantities, one of the unknown quantities must be eliminated between two pairs of the equations; then a second between the two resulting equations.

**Quadratic equations.** — A quadratic equation contains the square of the unknown quantity, but no higher power. A pure quadratic contains the square only; an affected quadratic both the square and the first power.

*To solve a pure quadratic,* collect the unknown quantities on one side, and the known quantities on the other; divide by the coefficient of the unknown quantity and extract the square root of each side of the resulting equation.

$$\text{Solve } 3x^2 - 15 = 0. \quad 3x^2 = 15; x^2 = 5; x = \sqrt{5}.$$

A root like  $\sqrt{5}$ , which is indicated, but which can be found only approximately, is called a *surd*.

Solve  $3x^2 + 15 = 0$ .  $3x^2 = -15$ ;  $x^2 = -5$ ;  $x = \sqrt{-5}$ .

The square root of  $-5$  cannot be found even approximately, for the square of any number positive or negative is positive; therefore a root which is indicated, but cannot be found even approximately, is called *imaginary*.

To solve an affected quadratic, 1. Convert the equation into the form  $a^2x^2 \pm 2abx = c$ , multiplying or dividing the equation if necessary, so as to make the coefficient of  $x^2$  a square number.

2. Complete the square of the first member of the equation, so as to convert it to the form of  $a^2x^2 \pm 2abx + b^2$ , which is the square of the binomial  $ax \pm b$ , as follows: add to each side of the equation the square of the quotient obtained by dividing the second term by twice the square root of the first term.

3. Extract the square root of each side of the resulting equation.

Solve  $3x^2 - 4x = 32$ . To make the coefficient of  $x^2$  a square number, multiply by 3:  $9x^2 - 12x = 96$ ;  $12x \div (2 \times 3x) = 2$ ;  $2^2 = 4$ .

Complete the square:  $9x^2 - 12x + 4 = 100$ . Extract the root:  $3x - 2 = \pm 10$ , whence  $x = 4$  or  $-2\frac{2}{3}$ . The square root of 100 is either  $+10$  or  $-10$ , since the square of  $-10$  as well as  $+10^2 = 100$ .

Every affected quadratic may be reduced to the form  $ax^2 + bx + c = 0$ .

The solution of this equation is  $x = \frac{-b \pm \sqrt{b^2 - 4ac}}{2a}$ .

Problems involving quadratic equations have apparently two solutions, as a quadratic has two roots. Sometimes both will be true solutions, but generally one only will be a solution and the other be inconsistent with the conditions of the problem.

The sum of the squares of two consecutive positive numbers is 481. Find the numbers.

Let  $x =$  one number,  $x+1$  the other.  $x^2 + (x+1)^2 = 481$ .  $2x^2 + 2x + 1 = 481$ .

$x^2 + x = 240$ . Completing the square,  $x^2 + x + 0.25 = 240.25$ . Extracting the root we obtain  $x + 0.5 = \pm 15.5$ ;  $x = 15$  or  $-16$ . The negative root  $-16$  is inconsistent with the conditions of the problem.

Quadratic equations containing two unknown quantities require different methods for their solution, according to the form of the equations. For these methods reference must be made to works on algebra.

**Theory of exponents.** —  $\sqrt[n]{a}$  when  $n$  is a positive integer is one of  $n$  equal factors of  $a$ .  $\sqrt[n]{a^m}$  means  $a$  is to be raised to the  $m$ th power and the  $n$ th root extracted.

$(\sqrt[n]{a})^m$  means that the  $n$ th root of  $a$  is to be taken and the result raised to the  $m$ th power.

$\sqrt[n]{a^m} = (\sqrt[n]{a})^m = a^{\frac{m}{n}}$ . When the exponent is a fraction, the numerator indicates a power, and the denominator a root.  $a^{6/2} = \sqrt{a^6} = a^3$ ;  $a^{3/2} = \sqrt{a^3} = a^{1.5}$ .

To extract the root of a quantity raised to an indicated power, divide the exponent by the index of the required root; as,

$$\sqrt[n]{a^m} = a^{\frac{m}{n}}; \quad \sqrt[3]{a^6} = a^{6/3} = a^2.$$

Subtracting 1 from the exponent of  $a$  is equivalent to dividing by  $a$ :

$$a^{2-1} = a^1 = a; \quad a^{1-1} = a^0 = \frac{a}{a} = 1; \quad a^{0-1} = a^{-1} = \frac{1}{a}; \quad a^{-1-1} = a^{-2} = \frac{1}{a^2}.$$

A number with a negative exponent denotes the reciprocal of the number with the corresponding positive exponent.

A factor under the radical sign whose root can be taken may, by having the root taken, be removed from under the radical sign:

$$\sqrt{a^2b} = \sqrt{a^2} \times \sqrt{b} = a\sqrt{b}.$$

A factor outside the radical sign may be raised to the corresponding power and placed under it:

$$\sqrt{\frac{a}{b}} = \frac{\sqrt{ab}}{b} = \sqrt{ab \times \frac{1}{b^2}} = \frac{1}{b} \sqrt{ab}; \quad \sqrt{\frac{a}{b^2}} = \frac{1}{b} \sqrt{a}.$$

**Binomial Theorem.** — To obtain any power, as the  $n$ th, of an expression of the form  $x + a$

$$(a + x)^n = a^n + na^{n-1}x + \frac{n(n-1)a^{n-2}}{1.2}x^2 + \frac{n(n-1)(n-2)a^{n-3}}{1.2.3}x^3 + \text{etc.}$$

The following laws hold for any term in the expansion of  $(a + x)^n$ .  
 The exponent of  $x$  is less by one than the number of terms.  
 The exponent of  $a$  is  $n$  minus the exponent of  $x$ .

The last factor of the numerator is greater by one than the exponent of  $a$ .  
 The last factor of the denominator is the same as the exponent of  $x$ .

In the  $r$ th term the exponent of  $x$  will be  $r - 1$ .  
 The exponent of  $a$  will be  $n - (r - 1)$ , or  $n - r + 1$ .

The last factor of the numerator will be  $n - r + 2$ .  
 The last factor of the denominator will be  $= r - 1$ .

Hence the  $r$ th term =  $\frac{n(n-1)(n-2) \dots (n-r+2)}{1.2.3 \dots (r-1)} a^{n-r+1} x^{r-1}$ .

GEOMETRICAL PROBLEMS.

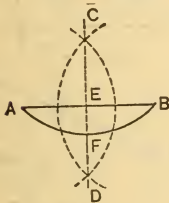

FIG. 1.

1. To bisect a straight line, or an arc of a circle (Fig. 1). — From the ends  $A, B$ , as centres, describe arcs intersecting at  $C$  and  $D$ , and draw a line through  $C$  and  $D$  which will bisect the line at  $E$  or the arc at  $F$ .

2. To draw a perpendicular to a straight line, or a radial line to a circular arc. — Same as in Problem 1.  $CD$  is perpendicular to the line  $AB$ , and also radial to the arc.

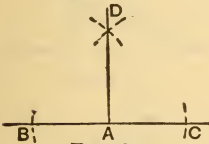

FIG. 2.

3. To draw a perpendicular to a straight line from a given point in that line (Fig. 2). — With any radius, from the given point  $A$  in the line  $BC$ , cut the line at  $B$  and  $C$ . With a longer radius describe arcs from  $B$  and  $C$ , cutting each other at  $D$ , and draw the perpendicular  $DA$ .

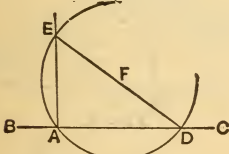

FIG. 3.

4. From the end  $A$  of a given line  $AD$  to erect a perpendicular  $AE$  (Fig. 3). — From any centre  $F$ , above  $AD$ , describe a circle passing through the given point  $A$ , and cutting the given line at  $D$ . Draw  $DF$  and produce it to cut the circle at  $E$ , and draw the perpendicular  $AE$ .

*Second Method* (Fig. 4). — From the given point  $A$  set off a distance  $AE$  equal to three parts, by any scale; and on the centres  $A$  and  $E$ , with radii of four and five parts respectively, describe arcs intersecting at  $C$ . Draw the perpendicular  $AC$ .

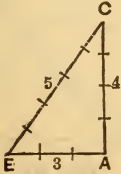

FIG. 4.

NOTE. — This method is most useful on very large scales, where straight edges are inapplicable. Any multiples of the numbers 3, 4, 5 may be taken with the same effect, as 6, 8, 10, or 9, 12, 15.

5. To draw a perpendicular to a straight line from any point without it (Fig. 5). — From the point  $A$ , with a sufficient radius cut the given line at  $F$  and  $G$ , and from these points describe arcs cutting at  $E$ . Draw the perpendicular  $AE$ .

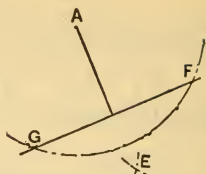

FIG. 5.

6. To draw a straight line parallel to a given line, at a given distance apart (Fig. 6). — From the centres  $A, B$ , in the given line, with the given distance as radius, describe arcs  $C, D$ , and draw the parallel lines  $CD$  touching the arcs.

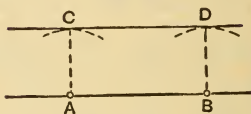

FIG. 6.

7. To divide a straight line into a number of equal parts (Fig. 7). — To divide the line  $AB$  into, say, five parts, draw the line  $AC$  at an angle from  $A$ ; set off five equal parts; draw  $B5$  and draw parallels to it from the other points of division in  $AC$ . These parallels divide  $AB$  as required.

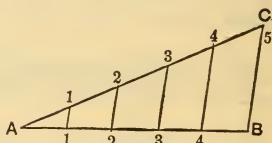

FIG. 7.

NOTE. — By a similar process a line may be divided into a number of unequal parts; setting off divisions on  $AC$ , proportional by a scale to the required divisions, and drawing parallels cutting  $AB$ . The triangles  $A11, A22, A33$ , etc., are *similar triangles*.

8. Upon a straight line to draw an angle equal to a given angle (Fig. 8). — Let  $A$  be the given angle and  $F'G$  the line. From the point  $A$  with any radius describe the arc  $DE$ . From  $F$  with the same radius describe the arc  $I'H$ . Set off the arc  $I'H$  equal to  $DE$ , and draw  $F'H$ . The angle  $F$  is equal to  $A$ , as required.

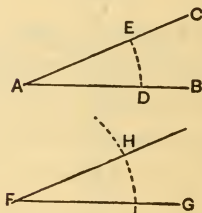

FIG. 8.

9. To draw angles of  $60^\circ$  and  $30^\circ$  (Fig. 9). — From  $F$ , with any radius  $FI$ , describe an arc  $I'H$ ; and from  $I$ , with the same radius, cut the arc at  $H$  and draw  $F'H$  to form the required angle  $I'FH$ . Draw the perpendicular  $H'K$  to the base line to form the angle of  $30^\circ$   $F'H'K$ .

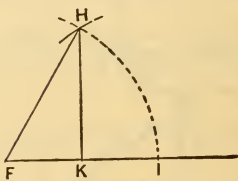

FIG. 9.

10. To draw an angle of  $45^\circ$  (Fig. 10). — Set off the distance  $FI$ ; draw the perpendicular  $I'H$  equal to  $IF$ , and join  $H'F$  to form the angle at  $F$ . The angle at  $H$  is also  $45^\circ$ .

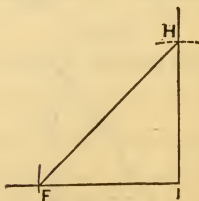

FIG. 10.



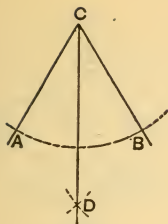

FIG. 11.

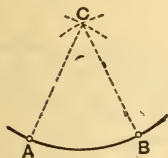

FIG. 12.

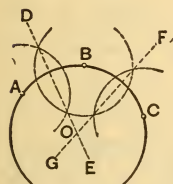

FIG. 13.

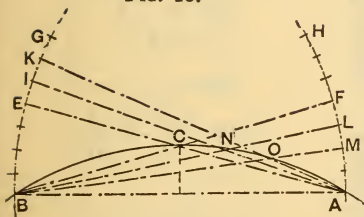

FIG. 14.

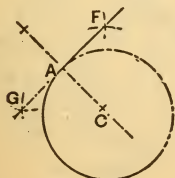

FIG. 15.

**11. To bisect an angle (Fig. 11).** — Let  $ACB$  be the angle; with  $C$  as a centre draw an arc cutting the sides at  $A, B$ . From  $A$  and  $B$  as centres, describe arcs cutting each other at  $D$ . Draw  $CD$ , dividing the angle into two equal parts.

**12. Through two given points to describe an arc of a circle with a given radius (Fig. 12).** — From the points  $A$  and  $B$  as centres, with the given radius, describe arcs cutting at  $C$ ; and from  $C$  with the same radius describe an arc  $AB$ .

**13. To find the centre of a circle or of an arc of a circle (Fig. 13).** — Select three points,  $A, B, C$ , in the circumference, well apart; with the same radius describe arcs from these three points, cutting each other, and draw the two lines,  $DE, FG$ , through their intersections. The point  $O$ , where they cut, is the centre of the circle or arc.

**To describe a circle passing through three given points.** — Let  $A, B, C$  be the given points, and proceed as in last problem to find the centre  $O$ , from which the circle may be described.

**14. To describe an arc of a circle passing through three given points when the centre is not available (Fig. 14).** — From the extreme points  $A, B$ , as centres, describe arcs  $AH, BG$ . Through the third point  $C$  draw  $AE, BF$ , cutting the arcs. Divide  $AF$  and  $BE$  into any number of equal parts, and set off a series of equal parts of the same length on the upper portions of the arcs beyond the points  $E, F$ . Draw straight lines,  $BL, BM$ , etc., to the divisions in  $AF$ , and  $AI, AK$ , etc., to the divisions in  $EG$ . The successive intersections  $N, O$ , etc., of these lines are points in the circle required between the given points  $A$  and  $C$ , which may be drawn in; similarly the remaining part of the curve  $BC$  may be described, (See also Problem 54.)

**15. To draw a tangent to a circle from a given point in the circumference (Fig. 15).** — Through the given point  $A$ , draw the radial line  $AC$ , and a perpendicular to it,  $FG$ , which is the tangent required.

**16. To draw tangents to a circle from a point without it (Fig. 16).**—From  $A$ , with the radius  $AC$ , describe an arc  $BCD$ , and from  $C$ , with a radius equal to the diameter of the circle, cut the arc at  $B, D$ . Join  $BC, CD$ , cutting the circle at  $EF$ , and draw  $AE, AF$ , the tangents.

**NOTE.**—When a tangent is already drawn, the exact point of contact may be found by drawing a perpendicular to it from the centre.

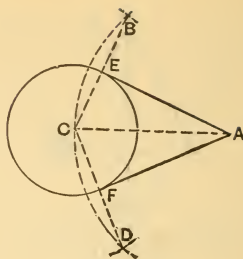

FIG. 16.

**17. Between two inclined lines to draw a series of circles touching these lines and touching each other (Fig. 17).**—Bisect the inclination of the given lines  $AB, CD$ , by the line  $NO$ . From a point  $P$  in this line draw the perpendicular  $PB$  to the line  $AB$ , and on  $P$  describe the circle  $BD$ , touching the lines and cutting the centre line at  $E$ . From  $E$  draw  $EF$  perpendicular to the centre line, cutting  $AB$  at  $F$ , and from  $F$  describe an arc  $EG$ , cutting  $AB$  at  $G$ . Draw  $GH$  parallel to  $BP$ , giving  $H$ , the centre of the next circle, to be described with the radius  $HE$ , and so on for the next circle  $IN$ .

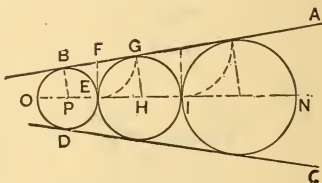

FIG. 17.

Inversely, the largest circle may be described first, and the smaller ones in succession. This problem is of frequent use in scroll-work.

**18. Between two inclined lines to draw a circular segment tangent to the lines and passing through a point  $F$  on the line  $FC$  which bisects the angle of the lines (Fig. 18).**—Through  $F$  draw  $DA$  at right angles to  $FC$ ; bisect the angles  $A$  and  $D$ , as in Problem 11, by lines cutting at  $C$ , and from  $C$  with radius  $CF$  draw the arc  $HFG$  required.

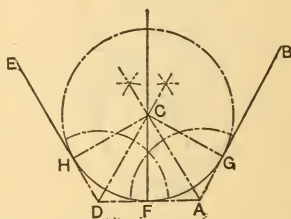

FIG. 18.

**19. To draw a circular arc that will be tangent to two given lines  $AB$  and  $CD$  inclined to one another, one tangential point  $E$  being given (Fig. 19).**—Draw the centre line  $GF$ . From  $E$  draw  $EF$  at right angles to  $AB$ ; then  $F$  is the centre of the circle required.

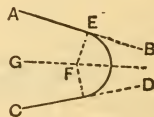

FIG. 19.

**20. To describe a circular arc joining two circles, and touching one of them at a given point (Fig. 20).**—To join the circles  $AB, FG$ , by an arc touching one of them at  $F$ , draw the radius  $EF$ , and produce it both ways. Set off  $FH$  equal to the radius  $AC$  of the other circle; join  $CH$  and bisect it with the perpendicular  $LI$ , cutting  $EF$  at  $I$ . On the centre  $I$ , with radius  $IF$ , describe the arc  $FA$  as required.

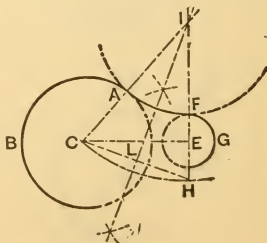

FIG. 20.

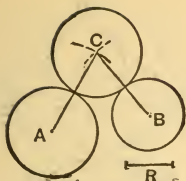

FIG. 21.

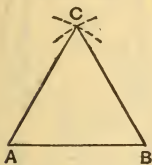

FIG. 22.

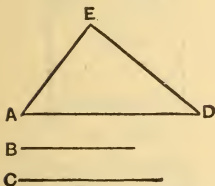

FIG. 23.

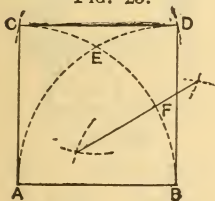

FIG. 24.

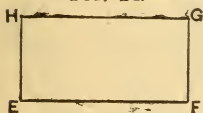

FIG. 25.

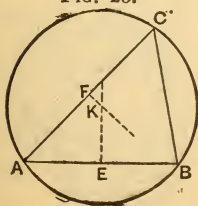

FIG. 26.

21. To draw a circle with a given radius  $R$  that will be tangent to two given circles  $A$  and  $B$  (Fig. 21). — From centre of circle  $A$  with radius equal  $R$  plus radius of  $A$ , and from centre of  $B$  with radius equal to  $R +$  radius of  $B$ , draw two arcs cutting each other in  $C$ , which will be the centre of the circle required.

22. To construct an equilateral triangle, the sides being given (Fig. 22). — On the ends of one side,  $A, B$ , with  $AB$  as radius, describe arcs cutting at  $C$ , and draw  $AC, CB$ .

23. To construct a triangle of unequal sides (Fig. 23). — On either end of the base  $AD$ , with the side  $B$  as radius, describe an arc; and with the side  $C$  as radius, on the other end of the base as a centre, cut the arc at  $E$ . Join  $AE, DE$ .

24. To construct a square on a given straight line  $AB$  (Fig. 24). — With  $AB$  as radius and  $A$  and  $B$  as centres, draw arcs  $AD$  and  $BC$ , intersecting at  $E$ . Bisect  $EB$  at  $F$ . With  $E$  as centre and  $EF$  as radius, cut the arcs  $AD$  and  $BC$  in  $D$  and  $C$ . Join  $AC, CD$ , and  $DB$  to form the square.

25. To construct a rectangle with given base  $EF$  and height  $EH$  (Fig. 25). — On the base  $EF$  draw the perpendiculars  $EH, FG$  equal to the height, and join  $GH$ .

26. To describe a circle about a triangle (Fig. 26). — Bisect two sides  $AB, AC$  of the triangle at  $E, F$ , and from these points draw perpendiculars cutting at  $K$ . On the centre  $K$ , with the radius  $KA$ , draw the circle  $ABC$ .

27. To inscribe a circle in a triangle (Fig. 27). — Bisect two of the angles  $A, C$ , of the triangle by

lines cutting at  $D$ ; from  $D$  draw a perpendicular  $DE$  to any side, and with  $DE$  as radius describe a circle.

When the triangle is equilateral, draw a perpendicular from one of the angles to the opposite side, and from the side set off one third of the perpendicular.

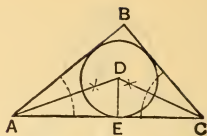

FIG. 27.

**28. To describe a circle about a square, and to inscribe a square in a circle (Fig. 28).** — To describe the circle, draw the diagonals  $AB$ ,  $CD$  of the square, cutting at  $E$ . On the centre  $E$ , with the radius  $AE$ , describe the circle.

**To inscribe the square.** — Draw the two diameters,  $AB$ ,  $CD$ , at right angles, and join the points  $A$ ,  $B$ ,  $C$ ,  $D$ , to form the square.

**NOTE.** — In the same way a circle may be described about a rectangle.

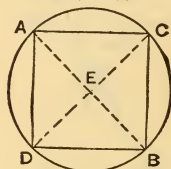

FIG. 28.

**29. To inscribe a circle in a square (Fig. 29).** — To inscribe the circle, draw the diagonals  $AB$ ,  $CD$  of the square, cutting at  $E$ ; draw the perpendicular  $EF$  to one side, and with the radius  $EF$  describe the circle.

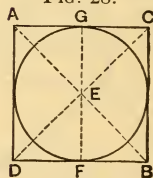

FIG. 29.

**30. To describe a square about a circle (Fig. 30).** — Draw two diameters  $AB$ ,  $CD$  at right angles. With the radius of the circle and  $A$ ,  $B$ ,  $C$  and  $D$  as centres, draw the four half circles which cross one another in the corners of the square.

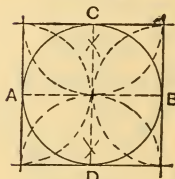

FIG. 30.

**31. To inscribe a pentagon in a circle (Fig. 31).** — Draw diameters  $AC$ ,  $BD$  at right angles, cutting at  $o$ . Bisect  $Ao$  at  $E$ , and from  $E$ , with radius  $EB$ , cut  $AC$  at  $F$ ; from  $B$ , with radius  $BF$ , cut the circumference at  $G$ ,  $H$ , and with the same radius step round the circle to  $I$  and  $K$ ; join the points so found to form the pentagon.

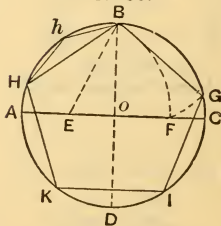

FIG. 31.

**32. To construct a pentagon on a given line  $AB$  (Fig. 32).** — From  $B$  erect a perpendicular  $BC$  half the length of  $AB$ ; join  $AC$  and prolong it to  $D$ , making  $CD = BC$ . Then  $BD$  is the radius of the circle circumscribing the pentagon. From  $A$  and  $B$  as centres, with  $BD$  as radius, draw arcs cutting each other in  $O$ , which is the centre of the circle.

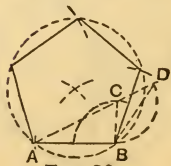

FIG. 32.



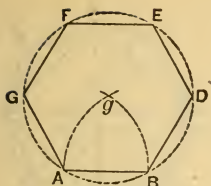

FIG. 33.

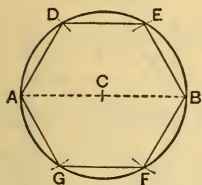

FIG. 34.

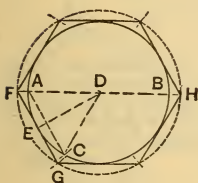

FIG. 35.

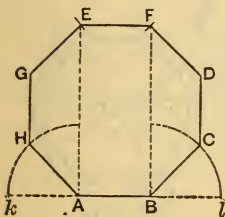

FIG. 36.

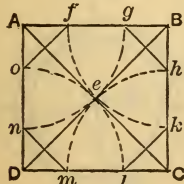

FIG. 37.

**33. To construct a hexagon upon a given straight line (Fig. 33).** — From *A* and *B*, the ends of the given line, with radius *AB*, describe arcs cutting at *g*; from *g*, with the radius *gA*, describe a circle; with the same radius set off the arcs *AG*, *GF*, and *BD*, *DE*. Join the points so found to form the hexagon. The side of a hexagon = radius of its circumscribed circle.

**34. To inscribe a hexagon in a circle (Fig. 34).** — Draw a diameter *ACB*. From *A* and *B* as centres, with the radius of the circle *AC*, cut the circumference, at *D*, *E*, *F*, *G*, and draw *AD*, *DE*, etc., to form the hexagon. The radius of the circle is equal to the side of the hexagon; therefore the points *D*, *E*, etc., may also be found by stepping the radius six times round the circle. The angle between the diameter and the sides of a hexagon and also the exterior angle between a side and an adjacent side prolonged is 60 degrees; therefore a hexagon may conveniently be drawn by the use of a 60-degree triangle.

**35. To describe a hexagon about a circle (Fig. 35).** — Draw a diameter *ADB*, and with the radius *AD*, on the centre *A*, cut the circumference at *C*; join *AC*, and bisect it with the radius *DE*; through *E* draw *FG*, parallel to *AC*, cutting the diameter at *F*, and with the radius *DF* describe the circumscribing circle *FH*. Within this circle, describe a hexagon by the preceding problem. A more convenient method is by use of a 60-degree triangle. Four of the sides make angles of 60 degrees with the diameter, and the other two are parallel to the diameter.

**36. To describe an octagon on a given straight line (Fig. 36).** — Produce the given line *AB* both ways, and draw perpendiculars *AE*, *BF*; bisect the external angles *A* and *B* by the lines *AH*, *BC*, which make equal to *AB*. Draw *CD* and *HG* parallel to *AE*, and equal to *AB*; from the centres *G*, *D*, with the radius *AB*, cut the perpendiculars at *E*, *F*, and draw *EF* to complete the octagon.

**37. To convert a square into an octagon (Fig. 37).** — Draw the diagonals of the square cutting at *e*; from the corners *A*, *B*, *C*, *D*, with *Ae* as radius, describe arcs cutting the sides at *gn*, *fk*, *hm*, and *ol*, and join the points so found to form the octagon. Adjacent sides of an octagon make an angle of 135 degrees.

**38. To inscribe an octagon in a circle (Fig. 38).** — Draw two diameters,  $A C, B D$  at right angles; bisect the arcs  $A B, B C$ , etc., at  $e f$ , etc., and join  $A e, e B$ , etc., to form the octagon.

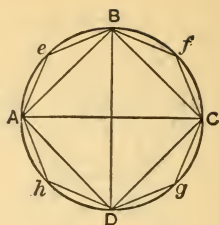

FIG. 38.

**39. To describe an octagon about a circle (Fig. 39).** — Describe a square about the given circle  $A B$ ; draw perpendiculars  $h k$ , etc., to the diagonals, touching the circle to form the octagon.

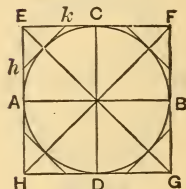

FIG. 39.

**40. To describe a polygon of any number of sides upon a given straight line (Fig. 40).** — Produce the given line  $A B$ , and on  $A$ , with the radius  $A B$ , describe a semicircle; divide the semi-circumference into as many equal parts as there are to be sides in the polygon — say, in this example, five sides. Draw lines from  $A$  through the divisional points  $D, b$ , and  $c$ , omitting one point  $a$ ; and on the centres  $B, D$ , with the radius  $A B$ , cut  $A b$  at  $E$  and  $A c$  at  $F$ . Draw  $D E, E F, F B$  to complete the polygon.

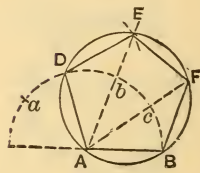

FIG. 40.

**41. To inscribe a circle within a polygon (Figs. 41, 42).** — When the polygon has an even number of sides (Fig. 41), bisect two opposite sides at  $A$  and  $B$ ; draw  $A B$ , and bisect it at  $C$  by a diagonal  $D E$ , and with the radius  $C A$  describe the circle.

When the number of sides is odd (Fig. 42), bisect two of the sides at  $A$  and  $B$ , and draw lines  $A E, B D$  to the opposite angles, intersecting at  $C$ ; from  $C$ , with the radius  $C A$ , describe the circle.

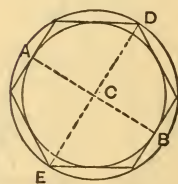

FIG. 41.

**42. To describe a circle without a polygon (Figs. 41, 42).** — Find the centre  $C$  as before, and with the radius  $C D$  describe the circle.

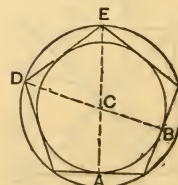

FIG. 42.

**43. To inscribe a polygon of any number of sides within a circle (Fig. 43).** — Draw the diameter  $A B$  and through the centre  $E$  draw the

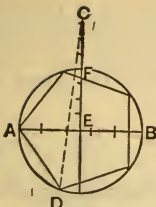

FIG. 43.

perpendicular  $EC$ , cutting the circle at  $F$ . Divide  $EF$  into four equal parts, and set off three parts equal to those from  $F$  to  $C$ . Divide the diameter  $AB$  into as many equal parts as the polygon is to have sides; and from  $C$  draw  $CD$ , through the second point of division, cutting the circle at  $D$ . Then  $AD$  is equal to one side of the polygon, and by stepping round the circumference with the length  $AD$  the polygon may be completed.

Table of Polygonal Angles.

Number of Sides.	Angle at Centre.	Number of Sides.	Angle at Centre.	Number of Sides.	Angle at Centre.
No. 3	Degrees. 120	No. 9	Degrees. 40	No. 15	Degrees. 24
4	90	10	36	16	22 1/2
5	72	11	32 8/11	17	21 3/17
6	60	12	30	18	20
7	51 3/7	13	27 9/13	19	19
8	45	14	25 5/7	20	18

In this table the angle at the centre is found by dividing 360 degrees, the number of degrees in a circle, by the number of sides in the polygon; and by setting off round the centre of the circle a succession of angles by means of the protractor, equal to the angle in the table due to a given number of sides, the radii so drawn will divide the circumference into the same number of parts.

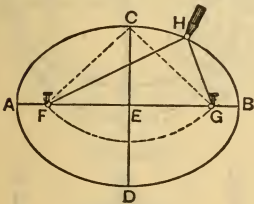

FIG. 44.

44. To describe an ellipse when the length and breadth are given (Fig. 44). —  $AB$ , transverse axis;  $CD$ , conjugate axis;  $F, G$ , foci. The sum of the distances from  $C$  to  $F$  and  $G$ , also the sum of the distances from  $F$  and  $G$  to any other point in the curve, is equal to the transverse axis. From the centre  $C$ , with  $AE$  as radius, cut the axis  $AB$  at  $F$  and  $G$ , the foci; fix a couple of pins into the axis at  $F$  and  $G$ , and loop on a thread or cord upon them equal in length to the axis  $AB$ , so as when stretched to reach to the extremity  $C$  of the conjugate axis, as shown in dot-lining. Place a pencil inside the cord as at  $H$ , and guiding the pencil in this way, keeping the cord equally in tension, carry the pencil round the pins  $F, G$ , and so describe the ellipse.

NOTE. — This method is employed in setting off elliptical garden-plots, walks, etc.

2d Method (Fig. 45). — Along the straight edge of a slip of stiff paper mark off a distance  $ac$  equal to  $AC$ , half the transverse axis; and from the same point a distance  $ab$  equal to  $CD$ , half the conjugate axis.

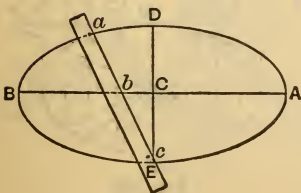

FIG. 45.

Place the slip so as to bring the point  $b$  on the line  $AB$  of the transverse axis, and the point  $c$  on the line  $DE$ ; and set off on the drawing the position of the point  $a$ . Shifting the slip so that the point  $b$  travels on the transverse axis, and the point  $c$  on the conjugate axis, any number of points in the curve may be found, through which the curve may be traced.

**3d Method** (Fig. 46). — The action of the preceding method may be embodied so as to afford the means of describing a large curve continuously by means of a bar  $mk$ , with steel points  $m, l, k$ , riveted into brass slides adjusted to the length of the semi-axis and fixed with set-screws. A rectangular cross  $EG$ , with guiding-slots is placed, coinciding with the two axes of the ellipse  $AC$  and  $BH$ . By sliding the points  $k, l$  in the slots, and carrying round the point  $m$ , the curve may be continuously described. A pen or pencil may be fixed at  $m$ .

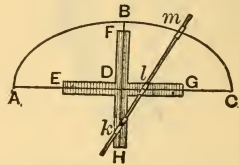

FIG. 46.

**4th Method** (Fig. 47). — Bisect the transverse axis at  $C$ , and through  $C$  draw the perpendicular  $DE$ , making  $CD$  and  $CE$  each equal to half the conjugate axis. From  $D$  or  $E$ , with the radius  $AC$ , cut the transverse axis at  $F, F'$ , for the foci. Divide  $AC$  into a number of parts at the points 1, 2, 3, etc. With the radius  $A1$  on  $F$  and  $F'$  as centres, describe arcs, and with the radius  $B1$  on the same centres cut these arcs as shown. Repeat the operation for the other divisions of the transverse axis. The series of intersections thus made are points in the curve, through which the curve may be traced.

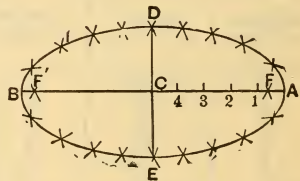

FIG. 47.

**5th Method** (Fig. 48). — On the two axes  $AB, DE$  as diameters, on centre  $C$ , describe circles; from a number of points  $a, b$ , etc., in the circumference  $AFB$ , draw radii cutting the inner circle at  $a', b'$ , etc. From  $a, b$ , etc., draw perpendiculars to  $AB$ ; and from  $a', b'$ , etc., draw parallels to  $AB$ , cutting the respective perpendiculars at  $n, o$ , etc. The intersections are points in the curve, through which the curve may be traced.

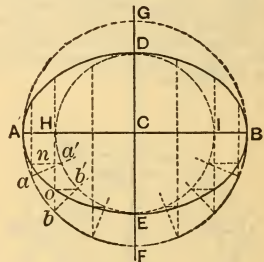

FIG. 48.

**6th Method** (Fig. 49). — When the transverse and conjugate diameters are given,  $AB, CD$ , draw the tangent  $EF$  parallel to  $AB$ . Produce  $CD$ , and on the centre  $G$  with the radius of half  $AB$ , describe a semicircle  $HDK$ ; from the centre  $G$  draw any number of straight lines to the points  $E, r$ , etc., in the line  $EF$ , cutting the circumference at  $l, m, n$ , etc.; from the centre  $O$  of the ellipse draw straight lines to the points  $E, r$ , etc.; and from the points  $l, m, n$ , etc., draw parallels to  $GC$ , cutting the lines  $OE, Or$ , etc., at  $L, M, N$ , etc.

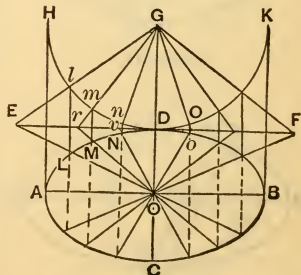

FIG. 49.



These are points in the circumference of the ellipse, and the curve may be traced through them. Points in the other half of the ellipse are formed by extending the intersecting lines as indicated in the figure.

**45. To describe an ellipse approximately by means of circular arcs.** — *First.* — With arcs of two radii (Fig. 50). — Find the difference of the semi-axes, and set it off from the centre  $O$  to  $a$  and  $c$  on  $OA$  and  $OC$ ; draw  $ac$ , and set off half  $ac$  to  $d$ ; draw  $di$  parallel to  $ac$ ; set off  $Oe$  equal to  $Od$ ; join  $ei$ , and draw the parallels  $em, dm$ . From  $m$ , with radius  $mC$ , describe an arc through  $C$ ; and from  $i$  describe an arc through  $D$ ; from  $d$  and  $e$  describe arcs through  $A$  and  $B$ . The four arcs form the ellipse approximately.

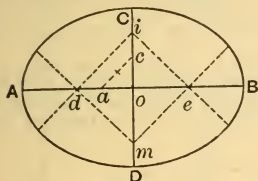

FIG. 50.

*NOTE.* — This method does not apply satisfactorily when the conjugate axis is less than two thirds of the transverse axis.

*2d Method* (by Carl G. Barth, Fig. 51). — In Fig. 51  $ab$  is the major and  $cd$  the minor axis of the ellipse to be approximated. Lay off  $be$  equal to the semi-minor axis  $cO$ , and use  $ae$  as radius for the arc at each extremity of the minor axis. Bisect  $eo$  at  $f$  and lay off  $eg$  equal to  $ef$ , and use  $gb$  as radius for the arc at each extremity of the major axis.

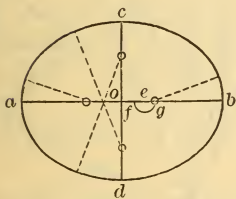

FIG. 51.

The method is not considered applicable for cases in which the minor axis is less than two thirds of the major.

*3d Method:* With arcs of three radii (Fig. 52). — On the transverse axis  $AB$  draw the rectangle  $BG$  on the height  $OC$ ; to the diagonal  $AC$  draw the perpendicular  $GH$ ; set off  $OK$  equal to  $OC$ , and describe a semicircle on  $AK$ , and produce  $OC$  to  $L$ ; set off  $OM$  equal to  $CL$ , and from  $D$  describe an arc with radius  $DM$ ; from  $A$ , with radius  $OL$ , cut  $AB$  at  $N$ ; from  $H$ , with radius  $HN$ , cut arc  $ab$  at  $a$ . Thus the five centres  $D, a, b, H, H'$  are found, from which the arcs are described to form the ellipse.

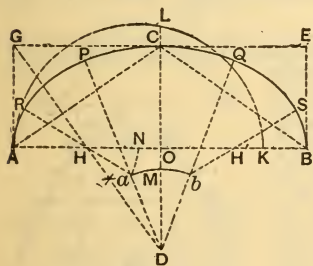

FIG. 52.

This process works well for nearly all proportions of ellipses. It is used in striking out vaults and stone bridges.

*4th Method* (by F. R. Honey, Figs. 53 and 54). — Three radii are employed. With the shortest radius describe the two arcs which pass through the vertices of the major axis, with the longest the two arcs which pass through the vertices of the minor axis, and with the third radius the four arcs which connect the former.

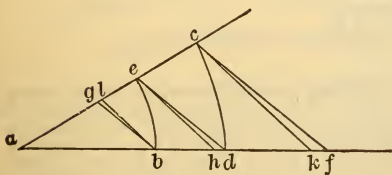

FIG. 53.

A simple method of determining the radii of curvature is illustrated in Fig. 53. Draw the straight lines  $a f$  and  $a c$ , forming any angle at  $a$ . With  $a$  as a centre, and with radii  $a b$  and  $a c$ , respectively, equal to the semi-minor and semi-major axes, draw the arcs  $b e$  and  $c d$ . Join  $e d$ , and through  $b$  and  $c$  respectively draw  $b g$  and  $c f$  parallel to  $e d$ , intersecting  $a c$  at  $g$ , and  $a f$  at  $f$ ;  $a f$  is the radius of curvature at the vertex of the minor axis; and  $a g$  the radius of curvature at the vertex of the major axis.

Lay off  $d h$  (Fig. 53) equal to one eighth of  $b d$ . Join  $e h$ , and draw  $c k$  and  $b l$  parallel to  $e h$ . Take  $a k$  for the longest radius ( $= R$ ),  $a l$  for the shortest radius ( $= r$ ), and the arithmetical mean, or one half the sum of the semi-axes, for the third radius ( $= p$ ), and employ these radii for the eight-centred oval as follows:

Let  $a b$  and  $c d$  (Fig. 54) be the major and minor axes. Lay off  $a e$  equal to  $r$ , and  $a f$  equal to  $p$ ; also lay off  $c g$  equal to  $R$ , and  $c h$  equal to  $p$ . With  $g$  as a centre and  $g h$  as a radius, draw the arc  $h k$ ; with the centre  $e$  and radius  $e f$  draw the arc  $f k$ , intersecting  $h k$  at  $k$ . Draw the line  $g k$  and produce it, making  $g l$  equal to  $R$ . Draw  $k e$  and produce it, making  $k m$  equal to  $p$ . With the centre  $g$  and radius  $g c$  ( $= R$ ) draw the arc  $c l$ ; with the centre  $k$  and radius  $k l$  ( $= p$ ) draw the arc  $l m$ , and with the centre  $e$  and radius  $e m$  ( $= r$ ) draw the arc  $m a$ .

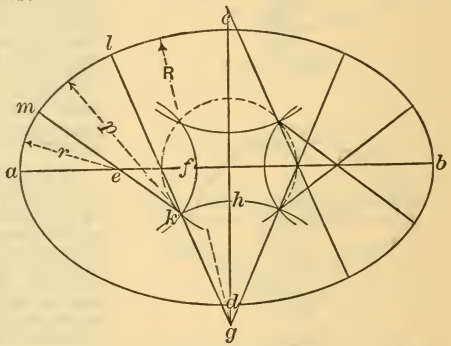

FIG. 54.

The remainder of the work is symmetrical with respect to the axes.

**46. The Parabola.** — A parabola ( $D A C$ , Fig. 55) is a curve such that every point in the curve is equally distant from the directrix  $K L$  and the focus  $F$ . The focus lies in the axis  $A B$  drawn from the vertex or head of the curve  $A$ , so as to divide the figure into two equal parts. The vertex  $A$  is equidistant from the directrix and the focus, or  $A e = A F$ . Any line parallel to the axis is a diameter. A straight line, as  $E G$  or  $D C$ , drawn across the figure at right angles to the axis is a double ordinate, and either half of it is an ordinate. The ordinate to the axis  $E F G$ , drawn through the focus, is called the parameter of the axis. A segment of the axis, reckoned from the vertex, is an abscissa of the axis, and it is an abscissa of the ordinate drawn from the base of the abscissa. Thus,  $A B$  is an abscissa of the ordinate  $B C$ .

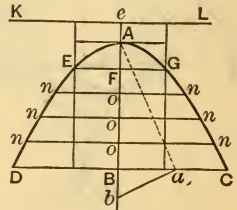

FIG. 55.

Abscissæ of a parabola are as the squares of their ordinates.

**To describe a parabola when an abscissa and its ordinate are given** (Fig. 55). — Bisect the given ordinate  $B C$  at  $a$ , draw  $A a$ , and then  $a b$  perpendicular to it, meeting the axis at  $b$ . Set off  $A e$ ,  $A F$ , each equal to  $B b$ ; and draw  $K e L$  perpendicular to the axis. Then  $K L$  is the directrix and  $F$  is the focus. Through  $F$  and any number of points,  $o, o$ , etc., in the axis, draw double ordinates,  $n o n$ , etc., and from the centre  $F$ , with the radii  $F e$ ,  $o e$ , etc., cut the respective ordinates at  $E, G, n, n$ , etc. The curve may be traced through these points as shown.

**2d Method:** By means of a square and a cord (Fig. 56). — Place a

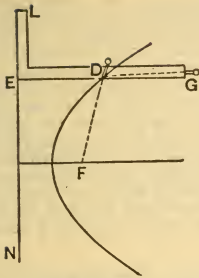

FIG. 56.

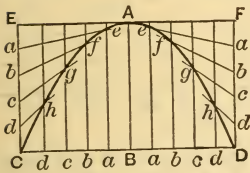

FIG. 57.

**47. The Hyperbola (Fig. 58).** — A hyperbola is a plane curve, such that the difference of the distances from any point of it to two fixed points is equal to a given distance. The fixed points are called the foci.

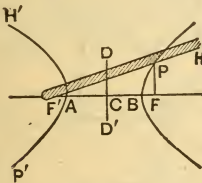

FIG. 58.

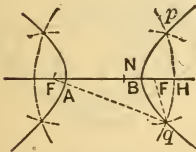

FIG. 59.

straight-edge to the directrix  $EN$ , and apply to it a square  $LEG$ . Fasten to the end  $G$  one end of a thread or cord equal in length to the edge  $EG$ , and attach the other end to the focus  $F$ ; slide the square along the straight-edge, holding the cord taut against the edge of the square by a pencil  $D$ , by which the curve is described.

**3d Method:** When the height and the base are given (Fig. 57). — Let  $AB$  be the given axis, and  $CD$  a double ordinate or base; to describe a parabola of which the vertex is at  $A$ . Through  $A$  draw  $EF$  parallel to  $CD$ , and through  $C$  and  $D$  draw  $CE$  and  $DF$  parallel to the axis. Divide  $BC$  and  $BD$  into any number of equal parts, say five, at  $a, b, c, d$ , etc., and divide  $CE$  and  $DF$  into the same number of parts. Through the points  $a, b, c, d$  in the base  $CD$  on each side of the axis draw perpendiculars, and through  $a, b, c, d$  in  $CE$  and  $DF$  draw lines to the vertex  $A$ , cutting the perpendiculars at  $e, f, g, h$ . These are points in the parabola, and the curve  $CAD$  may be traced as shown, passing through them.

**To construct a hyperbola.** — Let  $F'$  and  $F$  be the foci, and  $F'F$  the distance between them. Take a ruler longer than the distance  $F'F$ , and fasten one of its extremities at the focus  $F'$ . At the other extremity,  $H$ , attach a thread of such a length that the length of the ruler shall exceed the length of the thread by a given distance  $AB$ . Attach the other extremity of the thread at the focus  $F$ .

Press a pencil,  $P$ , against the ruler, and keep the thread constantly tense, while the ruler is turned around  $F'$  as a centre. The point of the pencil will describe one branch of the curve.

**2d Method:** By points (Fig. 59). — From the focus  $F'$  lay off a distance  $F'N$  equal to the transverse axis, or distance between the two branches of the curve, and take any other distance, as  $F'H$ , greater than  $F'N$ .

With  $F'$  as a centre and  $F'H$  as a radius describe the arc of a circle.

Then with  $F$  as a centre and  $NH$  as a radius describe an arc intersecting the arc before described at  $p$  and  $q$ . These will be points of the hyperbola, for  $F'q - Fq$  is equal to the transverse axis  $AB$ .

If, with  $F$  as a centre and  $F'H$  as a radius, an arc be described, and a second arc be described with  $F'$  as a centre and  $NH$  as a radius, two points in the other branch of the curve will be determined. Hence, by changing the centres, each pair of radii will determine two points in each branch.

**The Equilateral Hyperbola.** — The transverse axis of a hyperbola is

the distance, on a line joining the foci, between the two branches of the curve. The conjugate axis is a line perpendicular to the transverse axis, drawn from its centre, and of such a length that the diagonal of the rectangle of the transverse and conjugate axes is equal to the distance between the foci. The diagonals of this rectangle, indefinitely prolonged, are the *asymptotes* of the hyperbola, lines which the curve continually approaches, but touches only at an infinite distance. If these asymptotes are perpendicular to each other, the hyperbola is called a *rectangular* or *equilateral hyperbola*. It is a property of this hyperbola that if the asymptotes are taken as axes of a rectangular system of coördinates (see Analytical Geometry), the product of the abscissa and ordinate of any point in the curve is equal to the product of the abscissa and ordinate of any other point; or, if  $p$  is the ordinate of any point and  $v$  its abscissa, and  $p_1$  and  $v_1$  are the ordinate and abscissa of any other point,  $pv = p_1v_1$ ; or  $pv = a$  constant.

**48. The Cycloid** (Fig. 60). — If a circle  $A d$  be rolled along a straight line  $A 6$ , any point of the circumference as  $A$  will describe a curve, which is called a cycloid. The circle is called the generating circle, and  $A$  the generating point.

**To draw a cycloid.** — Divide the circumference of the generating circle into an even number of equal parts, as  $A 1, 2, 3, \dots$ , and set off these distances on the base. Through the draw horizontal lines, and on them set off distances  $1a = A1, 2b = A2, 3c = A3, \dots$ . The points  $A, a, b, c, \dots$ , will be points in the cycloid, through which draw the curve.

**49. The Epicycloid** (Fig. 61) is generated by a point  $D$  in one circle  $D C$  rolling upon the circumference of another circle  $A C B$ , instead of on a flat surface or line; the former being the generating circle, and the latter the fundamental circle. The generating circle is shown in four positions, in which the generating point is successively marked  $D, D', D'', D'''$ .  $A D''' B$  is the epicycloid.

**50. The Hypocycloid** (Fig. 62) is generated by a point in the generating circle rolling on the inside of the fundamental circle.

When the generating circle = radius of the other circle, the hypocycloid becomes a straight line.

**51. The Tractrix or Schiele's anti-friction curve** (Fig. 63). —  $R$  is the radius of the shaft,  $C, 1, 2, \dots$ , the axis. From  $O$  set off on  $R$  a small distance,  $oa$ ; with radius  $R$  and centre  $a$  cut the axis at 1, join  $a 1$ , and set off a like small distance  $ab$ ; from  $b$  with radius  $R$  cut axis at 2, join  $b 2$ , and so on, thus finding points  $o, a, b, c, d, \dots$ , through which the curve is to be drawn.

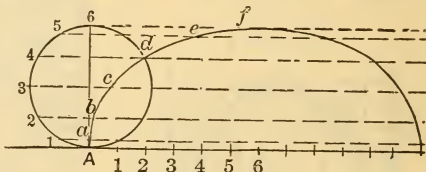

FIG. 60.

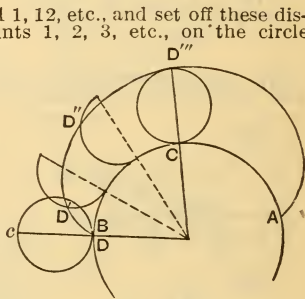

FIG. 61.

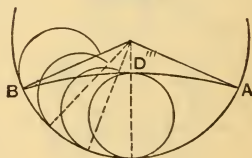

FIG. 62.



FIG. 63.



**52. The Spiral.** — The spiral is a curve described by a point which moves along a straight line according to any given law, the line at the same time having a uniform angular motion. The line is called the radius vector.

If the radius vector increases directly as the measuring angle, the spires, or parts described in each revolution, thus gradually increasing their distance from each other, the curve is known as the spiral of Archimedes (Fig. 64).

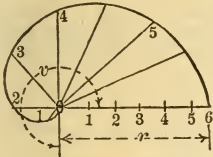

FIG. 64.

the distances 1, 2, 3, 4, etc., corresponding to the scale upon which the curve is drawn, as shown in Fig. 64.

This curve is commonly used for cams. To describe it draw the radius vector in several different directions around the centre, with equal angles between them; set off

In the common spiral (Fig. 64) the pitch is uniform; that is, the spires are equidistant. Such a spiral is made by rolling up a belt of uniform thickness.

**To construct a spiral with four centres** (Fig. 65). — Given the pitch of the spiral, construct a square about the centre, with the sum of the four sides equal to the pitch. Prolong the sides in one direction as shown; the corners are the centres for each arc of the external angles, forming a quadrant of a spire.

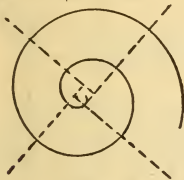

FIG. 65.

**53. To find the diameter of a circle into which a certain number of rings will fit on its inside** (Fig. 66). — For instance, what is the diameter of a circle into which twelve  $\frac{1}{2}$ -inch rings will fit, as per sketch? Assume that we have found the diameter of

the rings inside of it. Join the centres of the rings by straight lines, as shown: we then obtain a regular polygon with 12 sides, each side being equal to the diameter of a given ring. We have now to find the diameter of a circle circumscribed about this polygon, and add the diameter of one ring to it; the sum will be the diameter of the circle into which the rings will fit. Through the centres *A* and *D* of two adjacent rings draw the radii *CA* and *CD*; since the polygon has twelve sides the angle  $A C D = 30^\circ$  and  $A C B = 15^\circ$ . One half of the side *AD* is equal to *AB*. We now give the following proportion: The sine of the angle  $A C B$  is to *AB* as 1 is to the required radius. From this we

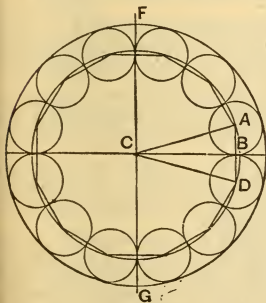

FIG. 66.

get the following rule: Divide *AB* by the sine of the angle  $A C B$ ; the quotient will be the radius of the circumscribed circle; add to the corresponding diameter the diameter of one ring; the sum will be the required diameter *FG*.

**54. To describe an arc of a circle which is too large to be drawn by a beam compass, by means of points in the arc, radius being given.** — Suppose the radius is 20 feet and it is desired to obtain five points in an arc whose half chord is 4 feet. Draw a line equal to the half chord, full size, or on a smaller scale if more convenient, and erect a perpendicular at one end, thus making rectangular axes of coordinates. Erect perpendiculars at points 1, 2, 3, and 4 feet from the first perpendicular. Find values of  $y$  in the formula of the circle,  $x^2 + y^2 = R^2$ , by substituting for

$x$  the values 0, 1, 2, 3, and 4, etc., and for  $R^2$  the square of the radius, or 400. The values will be  $y = \sqrt{R^2 - x^2} = \sqrt{400}, \sqrt{399}, \sqrt{396}, \sqrt{391}, \sqrt{384}; = 20, 19.975, 19.90, 19.774, 19.596.$

Subtract the smallest, or 19.596, leaving 0.404, 0.379, 0.304, 0.178, 0 feet. Lay off these distances on the five perpendiculars, as ordinates from the half chord, and the positions of five points on the arc will be found. Through these the curve may be drawn. (See also Problem 14.)

**55. The Catenary** is the curve assumed by a perfectly flexible cord when its ends are fastened at two points, the weight of a unit length being constant.

The equation of the catenary is  $y = \frac{a}{2} \left( e^{\frac{x}{a}} + e^{-\frac{x}{a}} \right)$ , in which  $e$  is the base of the Napierian system of logarithms.

**To plot the catenary.**— Let  $o$  (Fig. 67) be the origin of coördinates. Assigning to  $a$  any value as 3, the equation becomes

$$y = \frac{3}{2} \left( e^{\frac{x}{3}} + e^{-\frac{x}{3}} \right).$$

To find the lowest point of the curve.

Put  $x = 0$ ;  $\therefore y = \frac{3}{2} (e^0 + e^{-0}) = \frac{3}{2} (1 + 1) = 3.$

Then put  $x = 1$ ;  $\therefore y = \frac{3}{2} \left( e^{\frac{1}{3}} + e^{-\frac{1}{3}} \right) = \frac{3}{2} (1.396 + 0.717) = 3.17.$

Put  $x = 2$ ;  $\therefore y = \frac{3}{2} \left( e^{\frac{2}{3}} + e^{-\frac{2}{3}} \right) = \frac{3}{2} (1.948 + 0.513) = 3.69.$

Put  $x = 3, 4, 5, \text{etc.}, \text{etc.}$ , and find the corresponding values of  $y$ . For each value of  $y$  we obtain two symmetrical points, as for example  $p$  and  $p'$ . In this way, by making  $a$  successively equal to 2, 3, 4, 5, 6, 7, and 8, the curves of Fig. 67 were plotted.

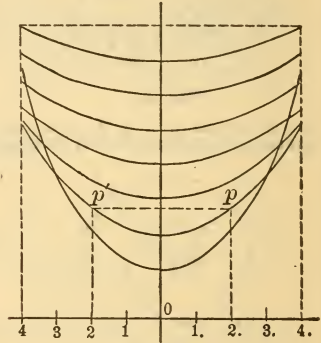

FIG. 67.

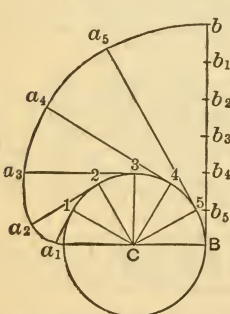

FIG. 68.

In each case the distance from the origin to the lowest point of the curve is equal to  $a$ ; for putting  $x = 0$ , the general equation reduces to  $y = a$ .

For values of  $a = 6, 7, \text{and } 8$  the catenary closely approaches the parabola. For derivation of the equation of the catenary see Bowser's Analytic Mechanics.

**56. The Involute** is a name given to the curve which is formed by the end of a string which is unwound from a cylinder and kept taut; consequently the string as it is unwound will always lie in the direction of a tangent to the cylinder. To describe the involute of any given circle, Fig. 68, take any point  $A$  on its circumference, draw a diameter  $AB$ , and from  $B$  draw  $Bb$  perpendicular to  $AB$ . Make  $Bb$  equal in length to half the circumference of the circle. Divide  $Bb$  and the semi-circumference into the same number of equal parts, say six. From each point of division 1, 2,

3, etc., on the circumference draw lines to the centre  $C$  of the circle. Then draw  $1a_1$  perpendicular to  $C1$ ;  $2a_2$  perpendicular to  $C2$ ; and so on. Make  $1a_1$  equal to  $b b_1$ ;  $2a_2$  equal to  $b b_2$ ;  $3a_3$  equal to  $b b_3$ ; and so on. Join the points  $A, a_1, a_2, a_3, \text{etc.}$ , by a curve; this curve will be the required involute.

**57. Method of plotting angles without using a protractor.**—The radius of a circle whose circumference is 360 is 57.3 (more accurately 57.296). Striking a semicircle with a radius 57.3 by any scale, spacers set to 10 by the same scale will divide the arc into 18 spaces of  $10^\circ$  each, and intermediates can be measured indirectly at the rate of 1 by scale for each  $1^\circ$ , or interpolated by eye according to the degree of accuracy required. The following table shows the chords to the above-mentioned radius, for every 10 degrees from  $0^\circ$  up to  $110^\circ$ . By means of one of these a  $10^\circ$  point is fixed upon the paper next less than the required angle, and the remainder is laid off at the rate of 1 by scale for each degree.

Angle.	Chord.	Angle.	Chord.	Angle.	Chord.
$1^\circ$ .....	0.999	$40^\circ$ .....	39.192	$80^\circ$ .....	73.658
$10^\circ$ .....	9.988	$50^\circ$ .....	48.429	$90^\circ$ .....	31.029
$20^\circ$ .....	19.899	$60^\circ$ .....	57.296	$100^\circ$ .....	87.782
$30^\circ$ .....	29.658	$70^\circ$ .....	65.727	$110^\circ$ .....	93.869

## GEOMETRICAL PROPOSITIONS.

In a right-angled triangle the square on the hypotenuse is equal to the sum of the squares on the other two sides.

If a triangle is equilateral, it is equiangular, and *vice versa*.

If a straight line from the vertex of an isosceles triangle bisects the base, it bisects the vertical angle and is perpendicular to the base.

If one side of a triangle is produced, the exterior angle is equal to the sum of the two interior and opposite angles.

If two triangles are mutually equiangular, they are similar and their corresponding sides are proportional.

If the sides of a polygon are produced in the same order, the sum of the exterior angles equals four right angles. (Not true if the polygon has re-entering angles.)

In a quadrilateral, the sum of the interior angles equals four right angles.

In a parallelogram, the opposite sides are equal; the opposite angles are equal; it is bisected by its diagonal, and its diagonals bisect each other.

If three points are not in the same straight line, a circle may be passed through them.

If two arcs are intercepted on the same circle, they are proportional to the corresponding angles at the centre.

If two arcs are similar, they are proportional to their radii.

The areas of two circles are proportional to the squares of their radii.

If a radius is perpendicular to a chord, it bisects the chord and it bisects the arc subtended by the chord.

A straight line tangent to a circle meets it in only one point, and it is perpendicular to the radius drawn to that point.

If from a point without a circle tangents are drawn to touch the circle, there are but two; they are equal, and they make equal angles with the chord joining the tangent points.

If two lines are parallel chords or a tangent and parallel chord, they intercept equal arcs of a circle.

If an angle at the circumference of a circle, between two chords, is subtended by the same arc as an angle at the centre, between two radii, the angle at the circumference is equal to half the angle at the centre.

If a triangle is inscribed in a semicircle, it is right-angled.

If two chords intersect each other in a circle, the rectangle of the segments of the one equals the rectangle of the segments of the other.

And if one chord is a diameter and the other perpendicular to it, the rectangle of the segments of the diameter is equal to the square on half the other chord, and the half chord is a mean proportional between the segments of the diameter.

If an angle is formed by a tangent and chord, it is measured by one half of the arc intercepted by the chord; that is, it is equal to half the angle at the centre subtended by the chord.



**Degree of a Railway Curve.** — This last proposition is useful in staking out railway curves. A curve is designated as one of so many degrees, and the degree is the angle at the centre subtended by a chord of 100 ft. To lay out a curve of  $n$  degrees the transit is set at its beginning or "point of curve," pointed in the direction of the tangent, and turned through  $\frac{1}{2}n$  degrees; a point 100 ft. distant in the line of sight will be a point in the curve. The transit is then swung  $\frac{1}{2}n$  degrees further and a 100 ft. chord is measured from the point already found to a point in the new line of sight, which is a second point or "station" in the curve.

The radius of a  $1^\circ$  curve is 5729.65 ft., and the radius of a curve of any degree is 5729.65 ft. divided by the number of degrees.

Some authors use the angle subtended by an arc (instead of chord) of 100 ft. in defining the degree of a curve. For a statement of the relative advantages of the two definitions, see *Eng. News*, Feb. 16, 1911.

## MENSURATION.

### PLANE SURFACES.

**Quadrilateral.** — A four-sided figure.

**Parallelogram.** — A quadrilateral with opposite sides parallel.

**Varieties.** — Square: four sides equal, all angles right angles. Rectangle: opposite sides equal, all angles right angles. Rhombus: four sides equal, opposite angles equal, angles not right angles. Rhomboid: opposite sides equal, opposite angles equal, angles not right angles.

**Trapezium.** — A quadrilateral with unequal sides.

**Trapezoid.** — A quadrilateral with only one pair of opposite sides parallel.

**Diagonal of a square** =  $\sqrt{2 \times \text{side}^2} = 1.4142 \times \text{side}$ .

**Diag. of a rectangle** =  $\sqrt{\text{sum of squares of two adjacent sides}}$ .

**Area of any parallelogram** = base  $\times$  altitude.

**Area of rhombus or rhomboid** = product of two adjacent sides  $\times$  sine of angle included between them.

**Area of a trapezoid** = product of half the sum of the two parallel sides by the perpendicular distance between them.

**To find the area of any quadrilateral figure.** — Divide the quadrilateral into two triangles; the sum of the areas of the triangles is the area.

Or, multiply half the product of the two diagonals by the sine of the angle at their intersection.

**To find the area of a quadrilateral which may be inscribed in a circle.** — From half the sum of the four sides subtract each side severally; multiply the four remainders together; the square root of the product is the area.

**Triangle.** — A three-sided plane figure.

**Varieties.** — Right-angled, having one right angle; obtuse-angled, having one obtuse angle; isosceles, having two equal angles and two equal sides; equilateral, having three equal sides and equal angles.

The sum of the three angles of every triangle =  $180^\circ$ .

The sum of the two acute angles of a right-angled triangle =  $90^\circ$ .

**Hypotenuse of a right-angled triangle, the side opposite the right angle,** =  $\sqrt{\text{sum of the squares of the other two sides}}$ . If  $a$  and  $b$  are the two sides and  $c$  the hypotenuse,  $c^2 = a^2 + b^2$ ;  $a = \sqrt{c^2 - b^2} = \sqrt{(c+b)(c-b)}$ .

If the two sides are equal, side = hyp  $\div 1.4142$ ; or hyp  $\times .7071$ .

**To find the area of a triangle:**

**RULE 1.** Multiply the base by half the altitude.

**RULE 2.** Multiply half the product of two sides by the sine of the included angle.

**RULE 3.** From half the sum of the three sides subtract each side severally; multiply together the half sum and the three remainders, and extract the square root of the product.

The area of an equilateral triangle is equal to one fourth the square of

one of its sides multiplied by the square root of 3, =  $\frac{a^2 \sqrt{3}}{4}$ ,  $a$  being the side; or  $a^2 \times 0.433013$ ,



Area of a triangle given, to find base: Base = twice area ÷ perpendicular height.

Area of a triangle given, to find height: Height = twice area ÷ base.

Two sides and base given, to find perpendicular height (in a triangle in which both of the angles at the base are acute).

RULE. — As the base is to the sum of the sides, so is the difference of the sides to the difference of the divisions of the base made by drawing the perpendicular. Half this difference being added to or subtracted from half the base will give the two divisions thereof. As each side and its opposite division of the base constitutes a right-angled triangle, the perpendicular is ascertained by the rule: Perpendicular =  $\sqrt{\text{hyp}^2 - \text{base}^2}$ .

Areas of similar figures are to each other as the squares of their respective linear dimensions. If the area of an equilateral triangle of side = 1 is 0.433013 and its height 0.86603, what is the area of a similar triangle whose height = 1?  $0.86603^2 : 1^2 :: 0.433013 : 0.57735$ , Ans.

Polygon. — A plane figure having three or more sides. Regular or irregular, according as the sides or angles are equal or unequal. Polygons are named from the number of their sides and angles.

To find the area of an irregular polygon. — Draw diagonals dividing the polygon into triangles, and find the sum of the areas of these triangles.

**To find the area of a regular polygon:**

RULE. — Multiply the length of a side by the perpendicular distance to the centre; multiply the product by the number of sides, and divide it by 2. Or, multiply half the perimeter by the perpendicular let fall from the centre on one of the sides.

The perpendicular from the centre is equal to half of one of the sides of the polygon multiplied by the cotangent of the angle subtended by the half side.

The angle at the centre =  $360^\circ$  divided by the number of sides.

**Table of Regular Polygons.**

No. of Sides.	Name of Polygon.	Area, Side = 1.	Area, Short diam.* = 1.	Radius of Circumscribed Circle.		Radius of Inscribed Circle, Side = 1.	Length of Side, Radius of Circumsc. Circle = 1.	Angle at Centre.	Angle between Adjacent Sides.
				Rad. of Inscr. Circle = 1.	Side = 1.				
3	Triangle	0.4330	0.5773	2.000	0.5773	0.2887	1.732	120°	60°
4	Square	1.0000	1.0000	1.414	0.7071	0.5000	1.4142	90	90
5	Pentagon	1.7205	0.7265	1.236	0.8506	0.6882	1.1756	72	108
6	Hexagon	2.5981	0.8660	1.155	1.0000	0.866	1.0000	60	120
7	Heptagon	3.6339	0.7572	1.11	1.1524	1.0383	0.8677	51 26'	128 4-7
8	Octagon	4.8284	0.8284	1.082	1.3066	1.2071	0.7653	45	135
9	Nonagon	6.1818	0.7688	1.064	1.4619	1.3737	0.684	40	140
10	Decagon	7.6942	0.8123	1.051	1.618	1.5388	0.618	36	144
11	Undecagon	9.3656	0.7744	1.042	1.7747	1.7028	0.5634	32 43'	147 3-11
12	Dodecagon	11.1962	0.8038	1.035	1.9319	1.866	0.5176	30	150

\* Short diameter, even number of sides, = diam. of inscribed circle; short diam., odd number of sides, = rad. of inscribed circle + rad. of circumscribed circle.

**To find the area of a regular polygon, when the length of a side only is given:**

**RULE.**—Multiply the square of the side by the figure for “area, side = 1,” opposite to the name of the polygon in the table.

**Length of a side of a regular polygon inscribed in a circle = diam.  $\times \sin (180^\circ \div \text{no. of sides})$ .**

No. of sides	$\sin (180^\circ/n)$	No. of sides	$\sin (180^\circ/n)$	No. of sides	$\sin (180^\circ/n)$
3	0.86603	9	0.34202	15	0.20791
4	.70711	10	.30902	16	.19509
5	.58778	11	.28173	17	.18375
6	.50000	12	.25882	18	.17365
7	.43388	13	.23931	19	.16458
8	.38268	14	.22252	20	.15643

**To find the area of an irregular figure (Fig. 69).**—Draw ordinates across its breadth at equal distances apart, the first and the last ordinate each being one half space from the ends of the figure. Find the average breadth by adding together the lengths of these lines included between the boundaries of the figure, and divide by the number of the lines added; multiply this mean breadth by the length. The greater the number of lines the nearer the approximation.

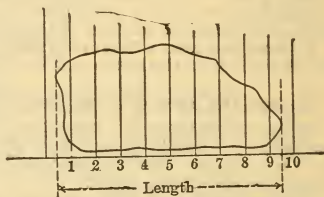

FIG. 69.

In a figure of very irregular outline, as an indicator-diagram from a high-speed steam-engine, mean lines may be substituted for the actual lines of the figure, being so traced as to intersect the undulations, so that the total area of the spaces cut off may be compensated by that of the extra spaces inclosed.

**2d Method: THE TRAPEZOIDAL RULE.**—Divide the figure into any sufficient number of equal parts; add half the sum of the two end ordinates to the sum of all the other ordinates; divide by the number of spaces (that is, one less than the number of ordinates) to obtain the mean ordinate, and multiply this by the length to obtain the area.

**3d Method: SIMPSON'S RULE.**—Divide the length of the figure into any even number of equal parts, at the common distance  $D$  apart, and draw ordinates through the points of division to touch the boundary lines. Add together the first and last ordinates and call the sum  $A$ ; add together the even ordinates and call the sum  $B$ ; add together the odd ordinates, except the first and last, and call the sum  $C$ . Then,

$$\text{area of the figure} = \frac{A + 4B + 2C}{3} \times D.$$

**4th Method: DURAND'S RULE.**—Add together  $\frac{4}{10}$  the sum of the first and last ordinates,  $\frac{11}{10}$  the sum of the second and the next to the last (or the penultimate), and the sum of all the intermediate ordinates. Multiply the sum thus gained by the common distance between the ordinates to obtain the area, or divide this sum by the number of spaces to obtain the mean ordinate.

Prof. Durand describes the method of obtaining his rule in *Engineering News*, Jan. 18, 1894. He claims that it is more accurate than Simpson's rule, and practically as simple as the trapezoidal rule. He thus describes its application for approximate integration of differential equations. Any definite integral may be represented graphically by an area. Thus, let

$$Q = \int u \, dx$$

be an integral in which  $u$  is some function of  $x$ , either known or admitting of computation or measurement. Any curve plotted with  $x$  as abscissa and  $u$  as ordinate will then represent the variation of  $u$  with  $x$ , and the

## MENSURATION.

area between such curve and the axis  $X$  will represent the integral in question, no matter how simple or complex may be the real nature of the function  $u$ .

Substituting in the rule as above given the word "volume" for "area" and the word "section" for "ordinate," it becomes applicable to the determination of volumes from equidistant sections as well as of areas from equidistant ordinates.

Having approximately obtained an area by the trapezoidal rule, the area by Durand's rule may be found by adding algebraically to the sum of the ordinates used in the trapezoidal rule (that is, half the sum of the end ordinates + sum of the other ordinates)  $\frac{1}{10}$  of (sum of penultimates - sum of first and last) and multiplying by the common distance between the ordinates.

*5th Method.* — Draw the figure on cross-section paper. Count the number of squares that are entirely included within the boundary; then estimate the fractional parts of squares that are cut by the boundary, add together these fractions, and add the sum to the number of whole squares. The result is the area in units of the dimensions of the squares. The finer the ruling of the cross-section paper the more accurate the result.

*6th Method.* — Use a planimeter.

*7th Method.* — With a chemical balance, sensitive to one milligram, draw the figure on paper of uniform thickness and cut it out carefully; weigh the piece cut out, and compare its weight with the weight per square inch of the paper as tested by weighing a piece of rectangular shape.

## THE CIRCLE.

Circumference = diameter  $\times$  3.1416, nearly; more accurately, 3.14159265359.

Approximations,  $\frac{22}{7} = 3.143$ ;  $\frac{355}{113} = 3.1415929$ .

The ratio of circum. to diam. is represented by the symbol  $\pi$  (called *Pi*).  
Area = 0.7854  $\times$  square of the diameter.

Multiples of $\pi$ .		Multiples of $\frac{\pi}{4}$ .
$1\pi = 3.14159265359$		$\pi/4 = 0.7853982$
$2\pi = 6.28318530718$		" $\times 2 = 1.5707963$
$3\pi = 9.42477796077$		" $\times 3 = 2.3561945$
$4\pi = 12.56637061436$		" $\times 4 = 3.1415927$
$5\pi = 15.70796326795$		" $\times 5 = 3.9269908$
$6\pi = 18.84955592154$		" $\times 6 = 4.7123890$
$7\pi = 21.99114857513$		" $\times 7 = 5.4977871$
$8\pi = 25.13274122872$		" $\times 8 = 6.2831853$
$9\pi = 28.27433388231$		" $\times 9 = 7.0685835$

Ratio of diam. to circumference = reciprocal of  $\pi = 0.3183099$ .

Reciprocal of $\pi/4 = 1.27324$ .	$10/\pi = 3.18310$	$1/\pi^2 = 0.101321$
Multiples of $1/\pi$ .	$12/\pi = 3.81972$	$\sqrt{\pi} = 1.772453$
$1/\pi = 0.31831$	$\pi/2 = 1.570796$	$\sqrt{1/\pi} = 0.564189$
$2/\pi = 0.63662$	$\pi/3 = 1.047197$	$\sqrt{\pi/4} = 0.886226$
$3/\pi = 0.95493$	$\pi/6 = 0.523599$	$\text{Log } \pi = 0.49714987$
$4/\pi = 1.27324$	$\pi/12 = 0.261799$	$\text{Log } \pi/4 = 1.895090$
$5/\pi = 1.59155$	$\pi/64 = 0.049087$	$\text{Log } \sqrt{\pi} = 0.248575$
$6/\pi = 1.90986$	$\pi/360 = 0.0087266$	$\text{Log } \sqrt{\pi/4} = 1.947545$
$7/\pi = 2.22817$	$360/\pi = 114.5915$	
$8/\pi = 2.54648$	$\pi^2 = 9.86960$	
$9/\pi = 2.86479$		

Diam. in ins. =  $13.5405 \sqrt{\text{area in sq. ft.}}$

Area in sq. ft. = (diam in inches)<sup>2</sup>  $\times$  .0054542.

$D$  = diameter,  $R$  = radius,  $C$  = circumference,  $A$  = area.

$$C = \pi D; = 2\pi R; = \frac{4A}{D}; = 2\sqrt{\pi A}; = 3.545\sqrt{A};$$

$$A = D^2 \times .7854; = \frac{CR}{2}; = 4R^2 \times .7854; = \pi R^2; = \frac{1}{4}\pi D^2; = \frac{C^2}{4\pi}; = .07958C^2; = \frac{CD}{4}.$$

$$D = \frac{C}{\pi}; = 0.31831C; = 2\sqrt{\frac{A}{\pi}}; = 1.12838\sqrt{A};$$

$$R = \frac{C}{2\pi}; = 0.159155C; = \sqrt{\frac{A}{\pi}}; = 0.564189\sqrt{A}.$$

Areas of circles are to each other as the squares of their diameters.

**To find the length of an arc of a circle:**

RULE 1. As 360 is to the number of degrees in the arc, so is the circumference of the circle to the length of the arc.

RULE 2. Multiply the diameter of the circle by the number of degrees in the arc, and this product by 0.0087266.

### Relations of Arc, Chord, Chord of Half the Arc, etc.

Let  $R$  = radius,  $D$  = diameter,  $L$  = length of arc,

$C$  = chord of the arc,  $c$  = chord of half the arc,

$V$  = rise, or height of the arc,

$$\begin{aligned} \text{Length of the arc} = L &= \frac{8c - C}{3} \text{ (very nearly), } = \frac{2c \times 10V}{60D - 27V} + 2c, \text{ nearly,} \\ &= \frac{\sqrt{C^2 + 4V^2} \times 10V^2}{15C^2 + 33V^2} + 2c, \text{ nearly.} \end{aligned}$$

$$\begin{aligned} \text{Chord of the arc } C &= 2\sqrt{c^2 - V^2}; = \sqrt{D^2 - (D - 2V)^2}; = 8c - 3L \\ &= 2\sqrt{R^2 - (R - V)^2}; = 2\sqrt{(D - V) \times V}. \end{aligned}$$

$$\text{Chord of half the arc, } c = \frac{1}{2}\sqrt{C^2 + 4V^2}; = \sqrt{D \times V}; = (3L + C) \div 8.$$

$$\text{Diameter of the circle, } D = \frac{c^2}{V}; = \frac{1/4 C^2 + V^2}{V};$$

$$\text{Rise of the arc, } V = \frac{c^2}{D}; = \frac{1}{2}(D - \sqrt{D^2 - C^2}),$$

$$\begin{aligned} \text{(or if } V \text{ is greater than radius } &\frac{1}{2}(D + \sqrt{D^2 - C^2}); \\ &= \sqrt{c^2 - 1/4 C^2}. \end{aligned}$$

Half the chord of the arc is a mean proportional between the rise and the diameter minus the rise:  $\frac{1}{2}C = \sqrt{V \times (D - V)}$ .

**Length of the Chord** subtending an angle at the centre = twice the sine of half the angle. (See Table of Sines.)

**Ordinates to Circular Arcs.** —  $C$  = chord,  $V$  = height of the arc, or middle ordinate,  $x$  = abscissa, or distance measured on the chord from its central point,  $y$  = ordinate, or distance from the arc to the chord at the point  $x$ ,  $V = R - \sqrt{R^2 - 1/4 C^2}$ ;  $y = \sqrt{R^2 - x^2} - (R - V)$ .

### Length of a Circular Arc. — Huyghens's Approximation.

Length of the arc,  $L = (8c - C) \div 3$ . Professor Williamson shows that when the arc subtends an angle of  $30^\circ$ , the radius being 100,000 feet (nearly 19 miles), the error by this formula is about two inches, or  $1/600900$  part of the radius. When the length of the arc is equal to the radius, i.e., when it subtends an angle of  $57^\circ.3$ , the error is less than  $1/7680$  part of the radius. Therefore, if the radius is 100,000 feet, the error is less than  $100000/7680 = 13$  feet. The error increases rapidly with the increase of the angle subtended. For an arc of  $120^\circ$  the error is 1 part in 400; for an arc of  $180^\circ$  the error is 1.18%.



In the measurement of an arc which is described with a short radius the error is so small that it may be neglected. Describing an arc with a radius of 12 inches subtending an angle of 30°, the error is 1/50000 of an inch.

To measure an arc when it subtends a large angle, bisect it and measure each half as before—in this case making  $B$  = length of the chord of half the arc, and  $b$  = length of the chord of one fourth the arc; then  $L = (16b - 2B) \div 3$ .

**Formulas for a Circular Curve.**

J. C. Locke, *Eng. News*, March 16, 1908.

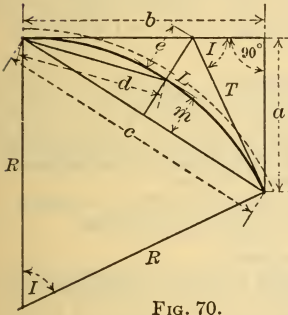

FIG. 70.

$$c = \sqrt{2Ra}, = \sqrt{a^2 + b^2},$$

$$= \sqrt{2R(R - \sqrt{(R + b)(R - b)})}$$

$$= 2\sqrt{m(2R - m)}, = 2R \sin 1/2 I,$$

$$= 2T \cos 1/2 I.$$

$$e = R \operatorname{exsec} 1/2 I, = R \tan 1/2 I \tan 1/4 I,$$

$$= T \tan 1/4 I.$$

$$b = \sqrt{a(2R - a)}, = \sqrt{\left(c + \frac{c^2}{2R}\right)\left(c - \frac{c^2}{2R}\right)},$$

$$= R \sin I, = a \cot 1/2 I.$$

$$R = \frac{a^2 + b^2}{2a}, = \frac{c^2}{2a}, = \frac{d^2}{2m}, = \frac{c^2 + 4m^2}{8m}.$$

$$d = \sqrt{2Rm}, = \sqrt{R(2R - \sqrt{(2R + c)(2R - c)})}, = 2R \sin 1/4 I.$$

$$m = \frac{d^2}{2R}, = R \mp \sqrt{\left(R + \frac{c}{2}\right)\left(R - \frac{c}{2}\right)}, = R \operatorname{vers} 1/2 I,$$

$$= R \sin 1/2 I \tan 1/4 I, = 1/2 c \tan 1/4 I.$$

$$a = \frac{c^2}{2R}, = R - \sqrt{(R + b)(R - b)}, = 2R (\sin 1/2 I)^2, = R \operatorname{vers} I,$$

$$= R \sin I \tan 1/2 I, = b \tan 1/2 I, = T \sin I.$$

$$T = R \tan 1/2 I. \quad I = \frac{L}{R} \times 57.295780^\circ. \quad R = \frac{L}{I} \times 57.295780^\circ.$$

$$L = IR \times 0.01745329, = \frac{8d - c}{3}.$$

$$\text{Area of Segment} = \frac{LR}{2} - \frac{R^2 \sin I}{2}, = \frac{LR}{2} - \frac{Rb}{2}.$$

**Relation of the Circle to its Equal, Inscribed, and Circumscribed Squares.**

Diameter of circle	× 0.88623	} = side of equal square.
Circumference of circle	× 0.28209	
Circumference of circle	× 1.1284	} = perimeter of equal square.
Diameter of circle	× 0.7071	
Circumference of circle	× 0.22508	} = side of inscribed square.
Area of circle ÷ diameter	× 0.90031	
Area of circle	× 1.2732	= area of circumscribed square.
Area of circle	× 0.63662	= area of inscribed square.
Side of square	× 1.4142	= diam. of circumscribed circle.
"	× 4.4428	= circum.
"	× 1.1284	= diam. of equal circle.
"	× 3.5449	= circum.
Perimeter of square	× 0.88623	= " " "
Square inches	× 1.2732	= circular inches.

**Sectors and Segments.** — *To find the area of a sector of a circle.*

**RULE 1.** Multiply the arc of the sector by half its radius.

**RULE 2.** As 360 is to the number of degrees in the arc, so is the area of the circle to the area of the sector.

**RULE 3.** Multiply the number of degrees in the arc by the square of the radius and by 0.008727.

*To find the area of a segment of a circle:* Find the area of the sector which has the same arc, and also the area of the triangle formed by the chord of the segment and the radii of the sector.

Then take the sum of these areas, if the segment is greater than a semi-circle, but take their difference if it is less. (See Table of Segments.)

*Another Method:* Area of segment =  $\frac{1}{2}R^2(\text{arc} - \sin A)$ , in which  $A$  is the central angle,  $R$  the radius, and arc the length of arc to radius 1.

*To find the area of a segment of a circle when its chord and height only are given.* First find radius, as follows:

$$\text{radius} = \frac{1}{2} \left[ \frac{\text{square of half the chord}}{\text{height}} + \text{height} \right].$$

2. Find the angle subtended by the arc, as follows: half chord ÷ radius = sine of half the angle. Take the corresponding angle from a table of sines, and double it to get the angle of the arc.

3. Find area of the sector of which the segment is a part:

$$\text{area of sector} = \text{area of circle} \times \text{degrees of arc} \div 360.$$

4. Subtract area of triangle under the segment:

$$\text{Area of triangle} = \text{half chord} \times (\text{radius} - \text{height of segment}).$$

The remainder is the area of the segment.

When the chord, arc, and diameter are given, to find the area. From the length of the arc subtract the length of the chord. Multiply the remainder by the radius or one-half diameter; to the product add the chord multiplied by the height, and divide the sum by 2.

Given diameter,  $d$ , and height of segment,  $h$ .

$$\begin{aligned} \text{When } h \text{ is from } 0 \text{ to } \frac{1}{4}d, \text{ area} &= h\sqrt{1.766dh - h^2}; \\ \text{" " " " } \frac{1}{4}d \text{ to } \frac{1}{2}d, \text{ area} &= h\sqrt{0.017d^2 + 1.7dh - h^2} \end{aligned}$$

(approx.). Greatest error 0.23%, when  $h = \frac{1}{4}d$ .

*To find the chord:* From the diameter subtract the height; multiply the remainder by four times the height and extract the square root.

When the chords of the arc and of half the arc and the rise are given: To the chord of the arc add four thirds of the chord of half the arc; multiply the sum by the rise and the product by 0.40426 (approximate).

**Circular Ring.** — *To find the area of a ring included between the circumferences of two concentric circles:* Take the difference between the areas of the two circles; or, subtract the square of the less radius from the square of the greater, and multiply their difference by 3.14159.

$$\begin{aligned} \text{The area of the greater circle is equal to } &\pi R^2; \\ \text{and the area of the smaller,} &\pi r^2. \end{aligned}$$

Their difference, or the area of the ring, is  $\pi(R^2 - r^2)$ .

**The Ellipse.** — Area of an ellipse = product of its semi-axes  $\times 3.14159$   
= product of its axes  $\times 0.785398$ .

*The Ellipse.* — Circumference (approximate) =  $3.1416 \sqrt{\frac{D^2 + d^2}{2}}$ ,  $D$  and  $d$  being the two axes.

Trautwine gives the following as more accurate: When the longer axis  $D$  is not more than five times the length of the shorter axis,  $d$ ,

$$\text{Circumference} = 3.1416 \sqrt{\frac{D^2 + d^2}{2} - \frac{(D - d)^2}{8.8}}$$

When  $D$  is more than  $5d$ , the divisor 8.8 is to be replaced by the following:

For $D/d =$	6	7	8	9	10	12	14	16	18	20	30	40	50
Divisor =	9	9.2	9.3	9.35	9.4	9.5	9.6	9.68	9.75	9.8	9.92	9.98	10

An accurate formula is  $C = \pi(a + b) \left( 1 + \frac{A^2}{4} + \frac{A^4}{64} + \frac{A^6}{256} + \frac{25A^8}{16384} + \dots \right)$ ,

in which  $A = \frac{a-b}{a+b}$ . — *Ingenieurs Taschenbuch*, 1896. ( $a$  and  $b$ , semi-axes.)

Carl G. Barth (*Machinery*, Sept., 1900) gives as a very close approximation to this formula

$$C = \pi(a + b) \frac{64 - 3A^4}{64 - 16A^2}$$

**Area of a segment of an ellipse** the base of which is parallel to one of the axes of the ellipse. Divide the height of the segment by the axis of which it is part, and find the area of a circular segment, in a table of circular segments, of which the height is equal to the quotient; multiply the area thus found by the product of the two axes of the ellipse.

**Cycloid.** — A curve generated by the rolling of a circle on a plane.

Length of a cycloidal curve =  $4 \times$  diameter of the generating circle.  
 Length of the base = circumference of the generating circle.  
 Area of a cycloid =  $3 \times$  area of generating circle.

**Helix (Screw).** — A line generated by the progressive rotation of a point around an axis and equidistant from its center.

**Length of a helix.** — To the square of the circumference described by the generating point add the square of the distance advanced in one revolution, and take the square root of their sum multiplied by the number of revolutions of the generating point. Or,

$$n\sqrt{c^2 + h^2} = \text{length, } n \text{ being number of revolutions.}$$

**Spirals.** — Lines generated by the progressive rotation of a point around a fixed axis, with a constantly increasing distance from the axis.

A *plane spiral* is made when the point rotates in one plane.

A *conical spiral* is made when the point rotates around an axis at a progressing distance from its center, and advancing in the direction of the axis, as around a cone.

**Length of a plane spiral line.** — When the distance between the coils is uniform.

**RULE.** — Add together the greater and less diameters; divide their sum by 2; multiply the quotient by 3.1416, and again by the number of revolutions. Or, take the mean of the length of the greater and less circumferences and multiply it by the number of revolutions. Or,

length =  $\pi n(R + r)$ ,  $R$  and  $r$  being the outer and inner radii. To find  $n$ , let  $t$  = thickness of coil or band,  $s$  = space between the coils,  $n = \frac{R-r-t}{t+s}$ .

**Length of a conical spiral line.** — Add together the greater and less diameters; divide their sum by 2 and multiply the quotient by 3.1416. To the square of the product of this circumference and the number of revolutions of the spiral add the square of the height of its axis and take the square root of the sum.

$$\text{Or, length} = \sqrt{\left( \pi n \frac{d+d'}{2} \right)^2 + h^2}$$

### SOLID BODIES.

**Surfaces and Volumes of Similar Solids.** — The surfaces of two similar solids are to each other as the squares of their linear dimensions; the volumes are as the cubes of their linear dimensions. If  $L$  = the side

of a cube or other solid, and  $l$  the side of a similar body of different size,  $S, s$ , the surfaces and  $V, v$ , the volumes respectively,  $S : s :: L^2 : l^2$ ;  $V : v :: L^3 : l^3$ .

**The Prism.** — *To find the surface of a right prism:* Multiply the perimeter of the base by the altitude for the convex surface. To this add the areas of the two ends when the entire surface is required.

Volume of a prism = area of its base  $\times$  its altitude.

**The pyramid.** — Convex surface of a regular pyramid = perimeter of its base  $\times$  half the slant height. To this add area of the base if the whole surface is required.

Volume of a pyramid = area of base  $\times$  one third of the altitude.

*To find the surface of a frustum of a regular pyramid:* Multiply half the slant height by the sum of the perimeters of the two bases for the convex surface. To this add the areas of the two bases when the entire surface is required.

*To find the volume of a frustum of a pyramid:* Add together the areas of the two bases and a mean proportional between them, and multiply the sum by one third of the altitude. (Mean proportional between two numbers = square root of their product.)

**Wedge.** — A wedge is a solid bounded by five planes, viz.: a rectangular base, two trapezoids, or two rectangles, meeting in an edge, and two triangular ends. The altitude is the perpendicular drawn from any point in the edge to the plane of the base.

*To find the volume of a wedge:* Add the length of the edge to twice the length of the base, and multiply the sum by one sixth of the product of the height of the wedge and the breadth of the base.

**Rectangular prismoid.** — A rectangular prismoid is a solid bounded by six planes, of which the two bases are rectangles, having their corresponding sides parallel, and the four upright sides of the solid are trapezoids.

*To find the volume of a rectangular prismoid:* Add together the areas of the two bases and four times the area of a parallel section equally distant from the bases, and multiply the sum by one sixth of the altitude.

**Cylinder.** — Convex surface of a cylinder = perimeter of base  $\times$  altitude. To this add the areas of the two ends when the entire surface is required.

Volume of a cylinder = area of base  $\times$  altitude.

**Cone.** — Convex surface of a cone = circumference of base  $\times$  half the slant height. To this add the area of the base when the entire surface is required.

Volume of a cone = area of base  $\times$  one third of the altitude.

*To find the surface of a frustum of a cone:* Multiply half the side by the sum of the circumferences of the two bases for the convex surface; to this add the areas of the two bases when the entire surface is required.

*To find the volume of a frustum of a cone:* Add together the areas of the two bases and a mean proportional between them, and multiply the sum by one third of the altitude. Or, Vol. =  $0.2618a(b^2 + c^2 + bc)$ ;  $a$  = altitude;  $b$  and  $c$ , diams. of the two bases.

**Sphere.** — *To find the surface of a sphere:* Multiply the diameter by the circumference of a great circle; or, multiply the square of the diameter by 3.14159.

Surface of sphere =  $4 \times$  area of its great circle.

“ “ “ = convex surface of its circumscribing cylinder.

Surfaces of spheres are to each other as the squares of their diameters.

*To find the volume of a sphere:* Multiply the surface by one third of the radius; or, multiply the cube of the diameter by  $\pi/6$ ; that is, by 0.5236.

Value of  $\pi/6$  to 10 decimal places = 0.5235987756.

The volume of a sphere =  $2/3$  the volume of its circumscribing cylinder.

Volumes of spheres are to each other as the cubes of their diameters.



**Spherical triangle.** — *To find the area of a spherical triangle:* Compute the surface of the quadrantal triangle, or one eighth of the surface of the sphere. From the sum of the three angles subtract two right angles; divide the remainder by 90, and multiply the quotient by the area of the quadrantal triangle.

**Spherical polygon.** — *To find the area of a spherical polygon:* Compute the surface of the quadrantal triangle. From the sum of all the angles subtract the product of two right angles by the number of sides less two; divide the remainder by 90 and multiply the quotient by the area of the quadrantal triangle.

**The prismoid.** — The prismoid is a solid having parallel end areas, and may be composed of any combination of prisms, cylinders, wedges, pyramids, or cones or frustums of the same, whose bases and apices lie in the end areas.

Inasmuch as cylinders and cones are but special forms of prisms and pyramids, and warped surface solids may be divided into elementary forms of them, and since frustums may also be subdivided into the elementary forms, it is sufficient to say that all prismoids may be decomposed into prisms, wedges, and pyramids. If a formula can be found which is equally applicable to all of these forms, then it will apply to any combination of them. Such a formula is called

**The Prismoidal Formula.**

Let  $A$  = area of the base of a prism, wedge, or pyramid;

$A_1, A_2, A_m$  = the two end and the middle areas of a prismoid, or of any of its elementary solids;  $h$  = altitude of the prismoid or elementary solid;  $V$  = its volume;

$$V = \frac{h}{6} (A_1 + 4A_m + A_2).$$

For a prism,  $A_1, A_m$  and  $A_2$  are equal, =  $A$ ;  $V = \frac{h}{6} \times 6A = hA$ .

For a wedge with parallel ends,  $A_2 = 0, A_m = \frac{1}{2} A_1$ ;  $V = \frac{h}{6} (A_1 + 2A_1) = \frac{hA}{2}$ .

For a cone or pyramid,  $A_2 = 0, A_m = \frac{1}{4} A_1$ ;  $V = \frac{h}{6} (A_1 + A_1) = \frac{hA}{3}$ .

The prismoidal formula is a rigid formula for all prismoids. The only approximation involved in its use is in the assumption that the given solid may be generated by a right line moving over the boundaries of the end areas.

The area of the middle section is never the mean of the two end areas if the prismoid contains any pyramids or cones among its elementary forms. When the three sections are similar in form the *dimensions* of the middle area are always the means of the corresponding end dimensions. This fact often enables the dimensions, and hence the area of the middle section, to be computed from the end areas.

**Polyedrons.** — A polyedron is a solid bounded by plane polygons. A regular polyedron is one whose sides are all equal regular polygons.

*To find the surface of a regular polyedron.* — Multiply the area of one of the faces by the number of faces; or, multiply the square of one of the edges by the surface of a similar solid whose edge is unity.

**A TABLE OF THE REGULAR POLYEDRONS WHOSE EDGES ARE UNITY.**

Names.	No. of Faces.	Surface.	Volume.
Tetraedron.....	4	1.7320508	0.1178513
Hexaedron.....	6	6.0000000	1.0000000
Octaedron.....	8	3.4641016	0.4714045
Dodecaedron.....	12	20.6457288	7.6631189
Icosaedron.....	20	8.6602540	2.1816950

**To find the volume of a regular polyedron.** — Multiply the surface by one third of the perpendicular let fall from the centre on one of the faces; or, multiply the cube of one of the edges by the solidity of a similar polyedron whose edge is unity.

**Solid of revolution.** — The volume of any solid of revolution is equal to the product of the area of its generating surface by the length of the path of the centre of gravity of that surface.

The convex surface of any solid of revolution is equal to the product of the perimeter of its generating surface by the length of path of its centre of gravity.

**Cylindrical ring.** — Let  $d$  = outer diameter;  $d'$  = inner diameter;  $\frac{1}{2}(d - d')$  = thickness =  $t$ ;  $\frac{1}{4}\pi t^2$  = sectional area;  $\frac{1}{2}(d + d')$  = mean diameter =  $M$ ;  $\pi t$  = circumference of section;  $\pi M$  = mean circumference of ring; surface =  $\pi t \times \pi M$ ; =  $\frac{1}{4}\pi^2(d^2 - d'^2)$ ; = 9.86965  $t M$ ; = 2.46741  $(d^2 - d'^2)$ ; volume =  $\frac{1}{4}\pi t^2 M \pi$ ; = 2.467241  $t^2 M$ .

**Spherical zone.** — Surface of a spherical zone or segment of a sphere = its altitude  $\times$  the circumference of a great circle of the sphere. A great circle is one whose plane passes through the centre of the sphere.

**Volume of a zone of a sphere.** — To the sum of the squares of the radii of the ends add one third of the square of the height; multiply the sum by the height and by 1.5708.

**Spherical segment.** — Volume of a spherical segment with one base. — Multiply half the height of the segment by the area of the base, and the cube of the height by 0.5236 and add the two products. Or, from three times the diameter of the sphere subtract twice the height of the segment; multiply the difference by the square of the height and by 0.5236. Or, to three times the square of the radius of the base of the segment add the square of its height, and multiply the sum by the height and by 0.5236.

**Spheroid or ellipsoid.** — When the revolution of the generating surface of the spheroid is about the transverse diameter the spheroid is *prolate*, and when about the conjugate it is *oblate*.

**Convex surface of a segment of a spheroid.** — Square the diameters of the spheroid, and take the square root of half their sum; then, as the diameter from which the segment is cut is to this root so is the height of the segment to the proportionate height of the segment to the mean diameter. Multiply the product of the other diameter and 3.1416 by the proportionate height.

**Convex surface of a frustum or zone of a spheroid.** — Proceed as by previous rule for the surface of a segment, and obtain the proportionate height of the frustum. Multiply the product of the diameter parallel to the base of the frustum and 3.1416 by the proportionate height of the frustum.

**Volume of a spheroid** is equal to the product of the square of the revolving axis by the fixed axis and by 0.5236. The volume of a spheroid is two thirds of that of the circumscribing cylinder.

**Volume of a segment of a spheroid.** — 1. When the base is parallel to the revolving axis, multiply the difference between three times the fixed axis and twice the height of the segment, by the square of the height and by 0.5236. Multiply the product by the square of the revolving axis, and divide by the square of the fixed axis.

2. When the base is perpendicular to the revolving axis, multiply the difference between three times the revolving axis and twice the height of the segment by the square of the height and by 0.5236. Multiply the product by the length of the fixed axis, and divide by the length of the revolving axis.

**Volume of the middle frustum of a spheroid.** — 1. When the ends are circular, or parallel to the revolving axis: To twice the square of the middle diameter add the square of the diameter of one end; multiply the sum by the length of the frustum and by 0.2618.

2. When the ends are elliptical, or perpendicular to the revolving axis: To twice the product of the transverse and conjugate diameters of the middle section add the product of the transverse and conjugate diameters of one end; multiply the sum by the length of the frustum and by 0.2618.

**Spindles.** — Figures generated by the revolution of a plane area, bounded by a curve other than a circle, when the curve is revolved about a chord perpendicular to its axis, or about its double ordinate. They are designated by the name of the arc or curve from which they are generated, as Circular, Elliptic, Parabolic, etc., etc.

*Convex surface of a circular spindle, zone, or segment of it.* — Rule: Multiply the length by the radius of the revolving arc; multiply this arc by the central distance, or distance between the centre of the spindle and centre of the revolving arc; subtract this product from the former, double the remainder, and multiply it by 3.1416.

*Volume of a circular spindle.* — Multiply the central distance by half the area of the revolving segment; subtract the product from one third of the cube of half the length, and multiply the remainder by 12.5664.

*Volume of frustum or zone of a circular spindle.* — From the square of half the length of the whole spindle take one third of the square of half the length of the frustum, and multiply the remainder by the said half length of the frustum; multiply the central distance by the revolving area which generates the frustum; subtract this product from the former, and multiply the remainder by 6.2832.

*Volume of a segment of a circular spindle.* — Subtract the length of the segment from the half length of the spindle; double the remainder and ascertain the volume of a middle frustum of this length; subtract the result from the volume of the whole spindle and halve the remainder.

*Volume of a cycloidal spindle* = five eighths of the volume of the circumscribing cylinder. — Multiply the product of the square of twice the diameter of the generating circle and 2.927 by its circumference, and divide this product by 8.

*Parabolic conoid.* — *Volume of a parabolic conoid* (generated by the revolution of a parabola on its axis). — Multiply the area of the base by half the height.

Or multiply the square of the diameter of the base by the height and by 0.3927.

*Volume of a frustum of a parabolic conoid.* — Multiply half the sum of the areas of the two ends by the height.

*Volume of a parabolic spindle* (generated by the revolution of a parabola on its base). — Multiply the square of the middle diameter by the length and by 0.4189. The volume of a parabolic spindle is to that of a cylinder of the same height and diameter as 8 to 15.

*Volume of the middle frustum of a parabolic spindle.* — Add together 8 times the square of the maximum diameter, 3 times the square of the end diameter, and 4 times the product of the diameters. Multiply the sum by the length of the frustum and by 0.05236. This rule is applicable for calculating the content of casks of parabolic form.

*Casks.* — *To find the volume of a cask of any form.* — Add together 39 times the square of the bung diameter, 25 times the square of the head diameter, and 26 times the product of the diameters. Multiply the sum by the length, and divide by 31,773 for the content in Imperial gallons, or by 26,470 for U. S. gallons.

This rule was framed by Dr. Hutton, on the supposition that the middle third of the length of the cask was a frustum of a parabolic spindle, and each outer third was a frustum of a cone.

*To find the ullage of a cask, the quantity of liquor in it when it is not full.*

1. For a *lying cask*: Divide the number of wet or dry inches by the bung diameter in inches. If the quotient is less than 0.5, deduct from it one fourth part of what it wants of 0.5. If it exceeds 0.5, add to it one fourth part of the excess above 0.5. Multiply the remainder or the sum by the whole content of the cask. The product is the quantity of liquor in the cask, in gallons, when the dividend is *wet* inches; or the empty space, if *dry* inches.

2. For a *standing cask*: Divide the number of wet or dry inches by the length of the cask. If the quotient exceeds 0.5, add to it one tenth of its excess above 0.5; if less than 0.5, subtract from it one tenth of what it wants of 0.5. Multiply the sum or the remainder by the whole content of the cask. The product is the quantity of liquor in the cask, when the dividend is *wet* inches; or the empty space, if *dry* inches.

*Volume of cask* (approximate) U. S. gallons = square of mean diam.  $\times$  length in inches  $\times$  0.0034. Mean diameter = half the sum of the bung and head diameters.

*Volume of an irregular solid.* — Suppose it divided into parts, resembling prisms or other bodies measurable by preceding rules. Find the content of each part; the sum of the contents is the cubic contents of the solid.



The content of a small part is found nearly by multiplying half the sum of the areas of each end by the perpendicular distance between them.

The contents of small irregular solids may sometimes be found by immersing them under water in a prismatic or cylindrical vessel, and observing the amount by which the level of the water descends when the solid is withdrawn. The sectional area of the vessel being multiplied by the descent of the level gives the cubic contents.

Or, weigh the solid in air and in water; the difference is the weight of water it displaces. Divide the weight in pounds by 62.4 to obtain volume in cubic feet, or multiply it by 27.7 to obtain the volume in cubic inches.

When the solid is very large and a great degree of accuracy is not requisite, measure its length, breadth, and depth in several different places, and take the mean of the measurement for each dimension, and multiply the three means together.

When the surface of the solid is very extensive it is better to divide it into triangles, to find the area of each triangle, and to multiply it by the mean depth of the triangle for the contents of each triangular portion; the contents of the triangular sections are to be added together.

The mean depth of a triangular section is obtained by measuring the depth at each angle, adding together the three measurements, and taking one third of the sum.

## PLANE TRIGONOMETRY.

### Trigonometrical Functions.

Every triangle has six parts — three angles and three sides. When any three of these parts are given, provided one of them is a side, the other parts may be determined. By the *solution* of a triangle is meant the determination of the unknown parts of a triangle when certain parts are given.

The *complement* of an angle or arc is what remains after subtracting the angle or arc from  $90^\circ$ .

In general, if we represent any arc by  $A$ , its complement is  $90^\circ - A$ . Hence the complement of an arc that exceeds  $90^\circ$  is negative.

The *supplement* of an angle or arc is what remains after subtracting the angle or arc from  $180^\circ$ . If  $A$  is an arc its supplement is  $180^\circ - A$ . The supplement of an arc that exceeds  $180^\circ$  is negative.

The *sum of the three angles of a triangle is equal to  $180^\circ$* . Either angle is the supplement of the other two. In a right-angled triangle, the right angle being equal to  $90^\circ$ , each of the acute angles is the complement of the other.

*In all right-angled triangles having the same acute angle, the sides have to each other the same ratio.* These ratios have received special names, as follows:

If  $A$  is one of the acute angles,  $a$  the opposite side,  $b$  the adjacent side, and  $c$  the hypotenuse.

The *sine* of the angle  $A$  is the quotient of the opposite side divided by the hypotenuse.  $\text{Sin } A = \frac{a}{c}$ .

The *tangent* of the angle  $A$  is the quotient of the opposite side divided by the adjacent side.  $\text{Tan } A = \frac{a}{b}$ .

The *secant* of the angle  $A$  is the quotient of the hypotenuse divided by the adjacent side.  $\text{Sec } A = \frac{c}{b}$ .

The *cosine* (cos), *cotangent* (cot), and *cosecant* (cosec) of an angle are respectively the sine, tangent, and secant of the complement of that angle. The terms sine, cosine, etc., are called trigonometrical functions.

In a circle whose radius is unity, the *sine* of an arc, or of the angle at the centre measured by that arc, is the perpendicular let fall from one extremity of the arc upon the diameter passing through the other extremity.

The *tangent* of an arc is the line which touches the circle at one extremity



of the arc, and is limited by the diameter (produced) passing through the other extremity.

**The secant of an arc** is that part of the produced diameter which is intercepted between the centre and the tangent.

**The versed sine of an arc** is that part of the diameter intercepted between the extremity of the arc and the foot of the sine.

In a circle whose radius is not unity, the trigonometric functions of an arc will be equal to the lines here defined, divided by the radius of the circle.

If  $\angle ICA$  (Fig. 71) is an angle in the first quadrant, and  $CF =$  radius,

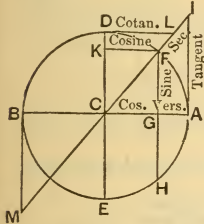

FIG. 71.

The sine of the angle =  $\frac{FG}{\text{Rad}}$ . Cos =  $\frac{CG}{\text{Rad}} = \frac{KF}{\text{Rad}}$ .

Tan =  $\frac{IA}{\text{Rad}}$ . Secant =  $\frac{CI}{\text{Rad}}$ . Cot =  $\frac{DL}{\text{Rad}}$ .

Cosec =  $\frac{CL}{\text{Rad}}$ . Versin =  $\frac{GA}{\text{Rad}}$ .

If radius is 1, then Rad in the denominator is omitted, and sine =  $FG$ , etc.

The sine of an arc = half the chord of twice the arc.

The sine of the supplement of the arc is the same as that of the arc itself. Sine of arc  $BDF = FG = \sin \text{arc } FA$ .

The tangent of the supplement is equal to the tangent of the arc, but with a contrary sign.  $\tan BDF = -BM$ .

The secant of the supplement is equal to the secant of the arc, but with a contrary sign.  $\sec BDF = -CM$ .

**Signs of the functions in the four quadrants.** — If we divide a circle into four quadrants by a vertical and a horizontal diameter, the upper right-hand quadrant is called the first, the upper left the second, the lower left the third, and the lower right the fourth. The signs of the functions in the four quadrants are as follows:

	First quad.	Second quad.	Third quad.	Fourth quad.
Sine and cosecant,	+	+	-	-
Cosine and secant,	+	-	-	+
Tangent and cotangent,	+	-	+	-

The values of the functions are as follows for the angles specified:

	0	30	45	60	90	120	135	150	180	270	360
Angle .....	0	30	45	60	90	120	135	150	180	270	360
Sine .....	0	$\frac{1}{2}$	$\frac{1}{\sqrt{2}}$	$\frac{\sqrt{3}}{2}$	1	$\frac{\sqrt{3}}{2}$	$\frac{1}{\sqrt{2}}$	$\frac{1}{2}$	0	-1	0
Cosine .....	1	$\frac{\sqrt{3}}{2}$	$\frac{1}{\sqrt{2}}$	$\frac{1}{2}$	0	$-\frac{1}{2}$	$-\frac{1}{\sqrt{2}}$	$-\frac{\sqrt{3}}{2}$	-1	0	1
Tangent .....	0	$\frac{1}{\sqrt{3}}$	1	$\sqrt{3}$	$\infty$	$-\sqrt{3}$	-1	$-\frac{1}{\sqrt{3}}$	0	$\infty$	0
Cotangent .....	$\infty$	$\sqrt{3}$	1	$\frac{1}{\sqrt{3}}$	0	$-\frac{1}{\sqrt{3}}$	-1	$-\sqrt{3}$	$\infty$	0	
Secant .....	1	$\frac{2}{\sqrt{3}}$	$\sqrt{2}$	2	$\infty$	-2	$-\sqrt{2}$	$-\frac{2}{\sqrt{3}}$	-1	$\infty$	1
Cosecant .....	$\infty$	2	$\sqrt{2}$	$\frac{2}{\sqrt{3}}$	1	$\frac{2}{\sqrt{3}}$	$\sqrt{2}$	2	$\infty$	-1	$\infty$
Versed sine ...	0	$\frac{2-\sqrt{3}}{2}$	$\frac{\sqrt{2}-1}{\sqrt{2}}$	$\frac{1}{2}$	1	$\frac{3}{2}$	$\frac{\sqrt{2}+1}{\sqrt{2}}$	$\frac{2+\sqrt{3}}{2}$	2	1	0

## TRIGONOMETRICAL FORMULAE.

The following relations are deduced from the properties of similar triangles (Radius = 1):

$$\cos A : \sin A :: 1 : \tan A, \text{ whence } \tan A = \frac{\sin A}{\cos A};$$

$$\sin A : \cos A :: 1 : \cot A, \quad \text{“ } \cotan A = \frac{\cos A}{\sin A};$$

$$\cos A : 1 \quad :: 1 : \sec A, \quad \text{“ } \sec A = \frac{1}{\cos A};$$

$$\sin A : 1 \quad :: 1 : \operatorname{cosec} A, \quad \text{“ } \operatorname{cosec} A = \frac{1}{\sin A};$$

$$\tan A : 1 \quad :: 1 : \cot A \quad \text{“ } \tan A = \frac{1}{\cot A}.$$

The sum of the square of the sine of an arc and the square of its cosine equals unity.  $\sin^2 A + \cos^2 A = 1$ .

$$\text{Also, } 1 + \tan^2 A = \sec^2 A; \quad 1 + \cot^2 A = \operatorname{cosec}^2 A.$$

**Functions of the sum and difference of two angles:**

Let the two angles be denoted by  $A$  and  $B$ , their sum  $A + B = C$ , and their difference  $A - B$  by  $D$ .

$$\sin (A + B) = \sin A \cos B + \cos A \sin B; \dots \dots \dots (1)$$

$$\cos (A + B) = \cos A \cos B - \sin A \sin B; \dots \dots \dots (2)$$

$$\sin (A - B) = \sin A \cos B - \cos A \sin B; \dots \dots \dots (3)$$

$$\cos (A - B) = \cos A \cos B + \sin A \sin B. \dots \dots \dots (4)$$

From these four formulæ by addition and subtraction we obtain

$$\sin (A + B) + \sin (A - B) = 2 \sin A \cos B; \dots \dots \dots (5)$$

$$\sin (A + B) - \sin (A - B) = 2 \cos A \sin B; \dots \dots \dots (6)$$

$$\cos (A + B) + \cos (A - B) = 2 \cos A \cos B; \dots \dots \dots (7)$$

$$\cos (A - B) - \cos (A + B) = 2 \sin A \sin B. \dots \dots \dots (8)$$

If we put  $A + B = C$ , and  $A - B = D$ , then  $A = \frac{1}{2}(C + D)$  and  $B = \frac{1}{2}(C - D)$ , and we have

$$\sin C + \sin D = 2 \sin \frac{1}{2}(C + D) \cos \frac{1}{2}(C - D); \dots \dots (9)$$

$$\sin C - \sin D = 2 \cos \frac{1}{2}(C + D) \sin \frac{1}{2}(C - D); \dots \dots (10)$$

$$\cos C + \cos D = 2 \cos \frac{1}{2}(C + D) \cos \frac{1}{2}(C - D); \dots \dots (11)$$

$$\cos D - \cos C = 2 \sin \frac{1}{2}(C + D) \sin \frac{1}{2}(C - D). \dots \dots (12)$$

Equation (9) may be enunciated thus: The sum of the sines of any two angles is equal to twice the sine of half the sum of the angles multiplied by the cosine of half their difference. These formulæ enable us to transform a sum or difference into a product.

The sum of the sines of two angles is to their difference as the tangent of half the sum of those angles is to the tangent of half their difference.

$$\frac{\sin A + \sin B}{\sin A - \sin B} = \frac{2 \sin \frac{1}{2}(A + B) \cos \frac{1}{2}(A - B)}{2 \cos \frac{1}{2}(A + B) \sin \frac{1}{2}(A - B)} = \frac{\tan \frac{1}{2}(A + B)}{\tan \frac{1}{2}(A - B)}. \quad (13)$$

The sum of the cosines of two angles is to their difference as the cotangent of half the sum of those angles is to the tangent of half their difference.

$$\frac{\cos A + \cos B}{\cos B - \cos A} = \frac{2 \cos \frac{1}{2}(A + B) \cos \frac{1}{2}(A - B)}{2 \sin \frac{1}{2}(A + B) \sin \frac{1}{2}(A - B)} = \frac{\cot \frac{1}{2}(A + B)}{\tan \frac{1}{2}(A - B)}. \quad (14)$$

The sine of the sum of two angles is to the sine of their difference as the sum of the tangents of those angles is to the difference of the tangents.

$$\frac{\sin (A + B)}{\sin (A - B)} = \frac{\tan A + \tan B}{\tan A - \tan B}; \dots \dots \dots (15)$$

$$\left. \begin{aligned} \frac{\sin(A+B)}{\cos A \cos B} &= \tan A + \tan B; \\ \frac{\sin(A-B)}{\cos A \cos B} &= \tan A - \tan B; \\ \frac{\cos(A+B)}{\cos A \cos B} &= 1 - \tan A \tan B; \\ \frac{\cos(A-B)}{\cos A \cos B} &= 1 + \tan A \tan B; \end{aligned} \right\} \begin{aligned} \tan(A+B) &= \frac{\tan A + \tan B}{1 - \tan A \tan B}; \\ \tan(A-B) &= \frac{\tan A - \tan B}{1 + \tan A \tan B}; \\ \cot(A+B) &= \frac{\cot A \cot B - 1}{\cot B + \cot A}; \\ \cot(A-B) &= \frac{\cot A \cot B + 1}{\cot B - \cot A}. \end{aligned}$$

**Functions of twice an angle:**

$$\left. \begin{aligned} \sin 2A &= 2 \sin A \cos A; \\ \tan 2A &= \frac{2 \tan A}{1 - \tan^2 A}; \end{aligned} \right\} \begin{aligned} \cos 2A &= \cos^2 A - \sin^2 A; \\ \cot 2A &= \frac{\cot^2 A - 1}{2 \cot A}. \end{aligned}$$

**Functions of half an angle:**

$$\left. \begin{aligned} \sin \frac{1}{2}A &= \pm \sqrt{\frac{1 - \cos A}{2}}; \\ \tan \frac{1}{2}A &= \pm \sqrt{\frac{1 - \cos A}{1 + \cos A}}; \end{aligned} \right\} \begin{aligned} \cos \frac{1}{2}A &= \pm \sqrt{\frac{1 + \cos A}{2}}; \\ \cot \frac{1}{2}A &= \pm \sqrt{\frac{1 + \cos A}{1 - \cos A}}. \end{aligned}$$

For tables of Trigonometric Functions, see Mathematical Tables.

**Solution of Plane Right-angled Triangles.**

Let  $A$  and  $B$  be the two acute angles and  $C$  the right angle, and  $a, b,$  and  $c$  the sides opposite these angles, respectively, then we have

$$\begin{aligned} 1. \sin A &= \cos B = \frac{a}{c}; & 3. \tan A &= \cot B = \frac{a}{b}; \\ 2. \cos A &= \sin B = \frac{b}{c}; & 4. \cot A &= \tan B = \frac{b}{a}. \end{aligned}$$

1. In any plane right-angled triangle the sine of either of the acute angles is equal to the quotient of the opposite leg divided by the hypotenuse.

2. The cosine of either of the acute angles is equal to the quotient of the adjacent leg divided by the hypotenuse.

3. The tangent of either of the acute angles is equal to the quotient of the opposite leg divided by the adjacent leg.

4. The cotangent of either of the acute angles is equal to the quotient of the adjacent leg divided by the opposite leg.

5. The square of the hypotenuse equals the sum of the squares of the other two sides.

**Solution of Oblique-angled Triangles.**

The following propositions are proved in works on plane trigonometry. In any plane triangle —

*Theorem 1.* The sines of the angles are proportional to the opposite sides.

*Theorem 2.* The sum of any two sides is to their difference as the tangent of half the sum of the opposite angles is to the tangent of half their difference.

*Theorem 3.* If from any angle of a triangle a perpendicular be drawn to the opposite side or base, the whole base will be to the sum of the other two sides as the difference of those two sides is to the difference of the segments of the base.

**CASE I.** Given two angles and a side, to find the third angle and the other two sides. 1. The third angle =  $180^\circ -$  sum of the two angles.

2. The sides may be found by the following proportion:

The sine of the angle opposite the given side is to the sine of the angle opposite the required side as the given side is to the required side.

CASE II. Given two sides and an angle opposite one of them, to find the third side and the remaining angles.

The side opposite the given angle is to the side opposite the required angle as the sine of the given angle is to the sine of the required angle.

The third angle is found by subtracting the sum of the other two from  $180^\circ$ , and the third side is found as in Case I.

CASE III. Given two sides and the included angle, to find the third side and the remaining angles.

The sum of the required angles is found by subtracting the given angle from  $180^\circ$ . The difference of the required angles is then found by Theorem II. Half the difference added to half the sum gives the greater angle, and half the difference subtracted from half the sum gives the less angle. The third side is then found by Theorem I.

Another method:

Given the sides  $c$ ,  $b$ , and the included angle  $A$ , to find the remaining side  $a$  and the remaining angles  $B$  and  $C$ .

From either of the unknown angles, as  $B$ , draw a perpendicular  $Be$  to the opposite side.

Then

$$Ae = c \cos A, \quad Be = c \sin A, \quad eC = b - Ae \quad Be \div eC = \tan C.$$

Or, in other words, solve  $Be$ ,  $Ae$  and  $BeC$  as right-angled triangles.

CASE IV. Given the three sides, to find the angles.

Let fall a perpendicular upon the longest side from the opposite angle, dividing the given triangle into two right-angled triangles. The two segments of the base may be found by Theorem III. There will then be given the hypotenuse and one side of a right-angled triangle to find the angles.

For areas of triangles, see Mensuration.

## ANALYTICAL GEOMETRY.

**Analytical geometry** is that branch of Mathematics which has for its object the determination of the forms and magnitudes of geometrical magnitudes by means of analysis.

**Ordinates and abscissas.** — In analytical geometry two intersecting lines  $YY'$ ,  $XX'$  are used as *coördinate axes*,  $XX'$  being the axis of abscissas or axis of  $X$ , and  $YY'$  the axis of ordinates or axis of  $Y$ .  $A$ , the intersection, is called the origin of coördinates. The distance of any point  $P$  from the axis of  $Y$  measured parallel to the axis of  $X$  is called the *abscissa* of the point, as  $AD$  or  $CP$ , Fig. 72. Its distance from the axis of  $X$ , measured parallel to the axis of  $Y$ , is called the *ordinate*, as  $AC$  or  $PD$ . The abscissa and ordinate taken together are called the *coördinates* of the point  $P$ . The angle of intersection is usually taken as a right angle, in which case the axes of  $X$  and  $Y$  are called *rectangular coördinates*.

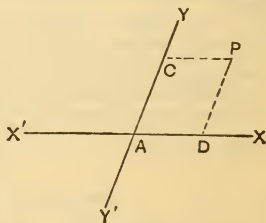

FIG. 72.

The abscissa of a point is designated by the letter  $x$  and the ordinate by  $y$ .

The *equations* of a point are the equations which express the distances of the point from the axis. Thus  $x = a$ ,  $y = b$  are the equations of the point  $P$ .

**Equations referred to rectangular coördinates.** — The equation of a line expresses the relation which exists between the coördinates of every point of the line.

Equation of a straight line,  $y = ax \pm b$ , in which  $a$  is the tangent of the angle the line makes with the axis of  $X$ , and  $b$  the distance above  $A$  in which the line cuts the axis of  $Y$ .

Every equation of the first degree between two variables is the equation



of a straight line, as  $Ay + Bx + C = 0$ , which can be reduced to the form  $y = ax \pm b$ .

Equation of the distance between two points:

$$D = \sqrt{(x'' - x')^2 + (y'' - y')^2},$$

in which  $x'y'$ ,  $x''y''$  are the coördinates of the two points.

Equation of a line passing through a given point:

$$y - y' = a(x - x'),$$

in which  $x'y'$  are the coördinates of the given point,  $a$ , the tangent of the angle the line makes with the axis of  $x$ , being undetermined, since any number of lines may be drawn through a given point.

Equation of a line passing through two given points:

$$y - y' = \frac{y'' - y'}{x'' - x'}(x - x').$$

Equation of a line parallel to a given line and through a given point:

$$y - y' = a(x - x').$$

Equation of an angle  $V$  included between two given lines:

$$\text{tang } V = \frac{a' - a}{1 + a'a},$$

in which  $a$  and  $a'$  are the tangents of the angles the lines make with the axis of abscissas.

If the lines are at right angles to each other  $\text{tang } V = \infty$ , and

$$1 + a'a = 0.$$

Equations of an intersection of two lines, whose equations are

$$\begin{aligned} y &= ax + b, & \text{and } y &= a'x + b', \\ x &= -\frac{b - b'}{a - a'}, & \text{and } y &= \frac{ab' - a'b}{a - a'}. \end{aligned}$$

Equation of a perpendicular from a given point to a given line:

$$y - y' = -\frac{1}{a}(x - x').$$

Equation of the length of the perpendicular  $P$ :

$$P = \frac{y' - ax' - b}{\sqrt{1 + a^2}}.$$

**The circle.** — Equation of a circle, the origin of coördinates being at the centre, and radius =  $R$ :

$$x^2 + y^2 = R^2.$$

If the origin is at the left extremity of the diameter, on the axis of  $X$ :

$$y^2 = 2Rx - x^2.$$

If the origin is at any point, and the coördinates of the centre are  $x'y'$

$$(x - x')^2 + (y - y')^2 = R^2.$$

Equation of a tangent to a circle, the coördinates of the point of tangency being  $x''y''$  and the origin at the centre,

$$yy'' + xx'' = R^2.$$

**The ellipse.** — Equation of an ellipse, referred to rectangular coördinates with axis at the centre:

$$A^2y^2 + B^2x^2 = A^2B^2,$$

in which  $A$  is half the transverse axis and  $B$  half the conjugate axis.

Equation of the ellipse when the origin is at the vertex of the transverse axis:

$$y^2 = \frac{B^2}{A^2}(2Ax - x^2).$$

The eccentricity of an ellipse is the distance from the centre to either focus, divided by the semi-transverse axis, or

$$e = \frac{\sqrt{A^2 - B^2}}{A}.$$

The parameter of an ellipse is the double ordinate passing through the focus. It is a third proportional to the transverse axis and its conjugate, or

$$2A : 2B :: 2B : \text{parameter}; \text{ or } \text{parameter} = \frac{2B^2}{A}.$$

Any ordinate of a circle circumscribing an ellipse is to the corresponding ordinate of the ellipse as the semi-transverse axis to the semi-conjugate. Any ordinate of a circle inscribed in an ellipse is to the corresponding ordinate of the ellipse as the semi-conjugate axis to the semi-transverse.

Equation of the tangent to an ellipse, origin of axes at the centre:

$$A^2yy'' + B^2xx'' = A^2B^2,$$

$y''x''$  being the coördinates of the point of tangency.

Equation of the normal, passing through the point of tangency, and perpendicular to the tangent:

$$y - y'' = \frac{A^2y''}{B^2x''}(x - x'').$$

The normal bisects the angle of the two lines drawn from the point of tangency to the foci.

The lines drawn from the foci make equal angles with the tangent.

**The parabola.** — Equation of the parabola referred to rectangular coördinates, the origin being at the vertex of its axis,  $y^2 = 2px$ , in which  $2p$  is the parameter or double ordinate through the focus.

The parameter is a third proportional to any abscissa and its corresponding ordinate, or

$$x : y :: y : 2p.$$

Equation of the tangent:

$$yy'' = p(x + x'').$$

$y''x''$  being coördinates of the point of tangency.

Equation of the normal:

$$y - y'' = -\frac{y''}{p}(x - x'').$$

The sub-normal, or projection of the normal on the axis, is constant, and equal to half the parameter.

The tangent at any point makes equal angles with the axis and with the line drawn from the point of tangency to the focus.

**The hyperbola.** — Equation of the hyperbola referred to rectangular coördinates, origin at the centre:

$$A^2y^2 - B^2x^2 = -A^2B^2,$$

in which  $A$  is the semi-transverse axis and  $B$  the semi-conjugate axis.

Equation when the origin is at the right vertex of the transverse axis:

$$y^2 = \frac{B^2}{A^2}(2Ax + x^2).$$

**Conjugate and equilateral hyperbolas.** — If on the conjugate axis,

as a transverse, and a focal distance equal to  $\sqrt{A^2 + B^2}$ , we construct the two branches of a hyperbola, the two hyperbolas thus constructed are called conjugate hyperbolas. If the transverse and conjugate axes are equal, the hyperbolas are called equilateral, in which case  $y^2 - x^2 = -A^2$  when  $A$  is the transverse axis, and  $x^2 - y^2 = -B^2$  when  $B$  is the transverse axis.

The parameter of the transverse axis is a third proportional to the transverse axis and its conjugate.

$$2A : 2B :: 2B : \text{parameter.}$$

The tangent to a hyperbola bisects the angle of the two lines drawn from the point of tangency to the foci.

The asymptotes of a hyperbola are the diagonals of the rectangle described on the axes, indefinitely produced in both directions.

The asymptotes continually approach the hyperbola, and become tangent to it at an infinite distance from the centre.

**Equilateral hyperbola.** — In an equilateral hyperbola the asymptotes make equal angles with the transverse axis, and are at right angles to each other. With the asymptotes as axes, and  $P$  = ordinate,  $V$  = abscissa,  $PV$  = a constant. This equation is that of the expansion of a perfect gas, in which  $P$  = absolute pressure,  $V$  = volume.

**Curve of Expansion of Gases.** —  $PV^n$  = a constant, or  $P_1V_1^n = P_2V_2^n$ , in which  $V_1$  and  $V_2$  are the volumes at the pressures  $P_1$  and  $P_2$ . When these are given, the exponent  $n$  may be found from the formula

$$n = \frac{\log P_1 - \log P_2}{\log V_2 - \log V_1}.$$

**Conic sections.** — Every equation of the second degree between two variables will represent either a circle, an ellipse, a parabola or a hyperbola. These curves are those which are obtained by intersecting the surface of a cone by planes, and for this reason they are called conic sections.

**Logarithmic curve.** — A logarithmic curve is one in which one of the coördinates of any point is the logarithm of the other.

The coördinate axis to which the lines denoting the logarithms are parallel is called the *axis of logarithms*, and the other the axis of numbers. If  $y$  is the axis of logarithms and  $x$  the axis of numbers, the equation of the curve is  $y = \log x$ .

If the base of a system of logarithms is  $a$ , we have  $a^y = x$ , in which  $y$  is the logarithm of  $x$ .

Each system of logarithms will give a different logarithmic curve. If  $y = 0$ ,  $x = 1$ . Hence every logarithmic curve will intersect the axis of numbers at a distance from the origin equal to 1.

## DIFFERENTIAL CALCULUS.

The differential of a variable quantity is the difference between any two of its consecutive values; hence it is indefinitely small. It is expressed by writing  $d$  before the quantity, as  $dx$ , which is read differential of  $x$ .

The term  $\frac{dy}{dx}$  is called the differential coefficient of  $y$  regarded as a function of  $x$ . It is also called the first derived function or the derivative.

The differential of a function is equal to its differential coefficient multiplied by the differential of the independent variable; thus,  $\frac{dy}{dx}dx = dy$ .

The *limit* of a variable quantity is that value to which it continually approaches, so as at last to differ from it by less than any assignable quantity.

The differential coefficient is the limit of the ratio of the increment of the independent variable to the increment of the function.

The differential of a constant quantity is equal to 0.

The differential of a product of a constant by a variable is equal to the constant multiplied by the differential of the variable.

$$\text{If } u = Av, \quad du = A dv.$$

In any curve whose equation is  $y = f(x)$ , the differential coefficient  $\frac{dy}{dx} = \tan a$ ; hence, the rate of increase of the function, or the ascension of the curve at any point, is equal to the tangent of the angle which the tangent line makes with the axis of abscissas.

All the operations of the Differential Calculus comprise but two objects:  
1. To find the rate of change in a function when it passes from one state of value to another, consecutive with it.

2. To find the actual change in the function: The rate of change is the differential coefficient, and the actual change the differential.

**Differentials of algebraic functions.** — The differential of the sum or difference of any number of functions, dependent on the same variable, is equal to the sum or difference of their differentials taken separately:

$$\text{If } u = y + z - w, \quad du = dy + dz - dw.$$

The differential of a product of two functions dependent on the same variable is equal to the sum of the products of each by the differential of the other:

$$d(uv) = v du + u dv. \quad \frac{d(uv)}{uv} = \frac{du}{u} + \frac{dv}{v}$$

The differential of the product of any number of functions is equal to the sum of the products which arise by multiplying the differential of each function by the product of all the others:

$$d(uts) = ts du + us dt + ut ds.$$

The differential of a fraction equals the denominator into the differential of the numerator minus the numerator into the differential of the denominator, divided by the square of the denominator:

$$dt = d\left(\frac{u}{v}\right) = \frac{v du - u dv}{v^2}.$$

If the denominator is constant,  $dv = 0$ , and  $dt = \frac{v du}{v^2} = \frac{du}{v}$ .

If the numerator is constant,  $du = 0$ , and  $dt = -\frac{u dv}{v^2}$ .

The differential of the square root of a quantity is equal to the differential of the quantity divided by twice the square root of the quantity:

$$\text{If } v = u^{1/2}, \quad \text{or } v = \sqrt{u}, \quad dv = \frac{du}{2\sqrt{u}}; = \frac{1}{2} u^{-1/2} du.$$

The differential of any power of a function is equal to the exponent multiplied by the function raised to a powerless one, multiplied by the differential of the function,  $d(u^n) = nu^{n-1} du$ .

### Formulas for differentiating algebraic functions.

$$1. \quad d(a) = 0.$$

$$2. \quad d(ax) = a dx.$$

$$3. \quad d(x + y) = dx + dy.$$

$$4. \quad d(x - y) = dx - dy.$$

$$5. \quad d(xy) = x dy + y dx.$$

$$6. \quad d\left(\frac{x}{y}\right) = \frac{y dx - x dy}{y^2}.$$

$$7. \quad d(x^m) = mx^{m-1} dx.$$

$$8. \quad d(\sqrt{x}) = \frac{dx}{2\sqrt{x}}.$$

$$9. \quad d\left(x^{-\frac{r}{s}}\right) = -\frac{r}{s} x^{-\frac{r}{s}-1} dx.$$

To find the differential of the form  $u = (a + bx^n)^m$ :

Multiply the exponent of the parenthesis into the exponent of the variable within the parenthesis, into the coefficient of the variable, into the



binomial raised to a power less 1, into the variable within the parenthesis raised to a power less 1, into the differential of the variable.

$$du = d(a + bx^n)^m = mnb(a + bx^n)^{m-1} x^{n-1} dx.$$

To find the rate of change for a given value of the variable:

Find the differential coefficient, and substitute the value of the variable in the second member of the equation.

EXAMPLE. — If  $x$  is the side of a cube and  $u$  its volume,  $u = x^3$ ,  $\frac{du}{dx} = 3x^2$ .

Hence the rate of change in the volume is three times the square of the edge. If the edge is denoted by 1, the rate of change is 3.

Application. The coefficient of expansion by heat of the volume of a body is three times the linear coefficient of expansion. Thus if the side of a cube expands 0.001 inch, its volume expands 0.003 cubic inch.  $1.001^3 = 1.003003001$ .

A **partial differential coefficient** is the differential coefficient of a function of two or more variables under the supposition that only one of them has changed its value.

A partial differential is the differential of a function of two or more variables under the supposition that only one of them has changed its value.

The total differential of a function of any number of variables is equal to the sum of the partial differentials.

If  $u = f(xy)$ , the partial differentials are  $\frac{du}{dx} dx$ ,  $\frac{du}{dy} dy$ .

If  $u = x^2 + y^3 - z$ ,  $du = \frac{du}{dx} dx + \frac{du}{dy} dy + \frac{du}{dz} dz$ ;  $= 2x dx + 3y^2 dy - dz$ .

**Integrals.** — An integral is a functional expression derived from a differential. Integration is the operation of finding the primitive function from the differential function. It is indicated by the sign  $\int$ , which is read "the integral of." Thus  $\int 2x dx = x^2$ ; read, the integral of  $2x dx$  equals  $x^2$ .

To integrate an expression of the form  $mx^{m-1}dx$  or  $x^m dx$ , add 1 to the exponent of the variable, and divide by the new exponent and by the differential of the variable:  $\int 3x^2 dx = x^3$ . (Applicable in all cases except when  $m = -1$ . For  $\int x^{-1} dx$  see formula 2, page 81.)

The integral of the product of a constant by the differential of a variable is equal to the constant multiplied by the integral of the differential:

$$\int ax^m dx = a \int x^m dx = a \frac{1}{m+1} x^{m+1}.$$

The integral of the algebraic sum of any number of differentials is equal to the algebraic sum of their integrals:

$$du = 2ax^2 dx - by dy - z^2 dz; \int du = \frac{2}{3} ax^3 - \frac{b}{2} y^2 - \frac{z^3}{3}.$$

Since the differential of a constant is 0, a constant connected with a variable by the sign + or - disappears in the differentiation; thus  $d(a + x^m) = dx^m = mx^{m-1} dx$ . Hence in integrating a differential expression we must annex to the integral obtained a constant represented by  $C$  to compensate for the term which may have been lost in differentiation. Thus if we have  $dy = a dx$ ;  $\int dy = a \int dx$ . Integrating,

$$y = ax \pm C.$$

The constant  $C$ , which is added to the first integral, must have such a value as to render the functional equation true for every possible value that may be attributed to the variable. Hence, after having found the first integral equation and added the constant  $C$ , if we then make the variable equal to zero, the value which the function assumes will be the true value of  $C$ .

An indefinite integral is the first integral obtained before the value of the constant  $C$  is determined.

A particular integral is the integral after the value of  $C$  has been found.

A definite integral is the integral corresponding to a given value of the variable.

**Integration between limits.** — Having found the indefinite integral and the particular integral, the next step is to find the definite integral, and then the definite integral between given limits of the variable.

The integral of a function, taken between two limits, indicated by given values of  $x$ , is equal to the difference of the definite integrals corresponding to those limits. The expression

$$\int_{x'}^{x''} dy$$

is read: Integral of the differential of  $y$ , taken between the limits  $x'$  and  $x''$ : the least limit, or the limit corresponding to the subtractive integral, being placed below.

Integrate  $du = 9x^2 dx$  between the limits  $x = 1$  and  $x = 3$ ,  $u$  being equal to 81 when  $x = 0$ .  $\int du = \int 9x^2 dx = 3x^3 + C$ ;  $C = 81$  when  $x = 0$ , then

$$\int_{x=1}^{x=3} du = 3(3)^3 + 81, \text{ minus } 3(1)^3 + 81 = 78.$$

### Integration of particular forms.

To integrate a differential of the form  $du = (a + bx^n)^m x^{n-1} dx$ .

1. If there is a constant factor, place it without the sign of the integral, and omit the power of the variable without the parenthesis and the differential;

2. Augment the exponent of the parenthesis by 1, and then divide this quantity, with the exponent so increased, by the exponent of the parenthesis, into the exponent of the variable within the parenthesis, into the coefficient of the variable. Whence

$$\int du = \frac{(a + bx^n)^{m+1}}{(m+1)nb} + C.$$

The differential of an arc is the hypotenuse of a right-angle triangle of which the base is  $dx$  and the perpendicular  $dy$ .

$$\text{If } z \text{ is an arc, } dz = \sqrt{dx^2 + dy^2} \quad z = \int \sqrt{dx^2 + dy^2}.$$

### Quadrature of a plane figure.

The differential of the area of a plane surface is equal to the ordinate into the differential of the abscissa.

$$ds = y dx.$$

To apply the principle enunciated in the last equation, in finding the area of any particular plane surface:

Find the value of  $y$  in terms of  $x$ , from the equation of the bounding line; substitute this value in the differential equation, and then integrate between the required limits of  $x$ .

**Area of the parabola.** — Find the area of any portion of the common parabola whose equation is

$$y^2 = 2px; \quad \text{whence } y = \sqrt{2px}.$$

Substituting this value of  $y$  in the differential equation  $ds = y dx$  gives

$$\int ds = \int \sqrt{2px} dx = \sqrt{2p} \int x^{1/2} dx = \frac{2\sqrt{2p}}{3} x^{3/2} + C;$$

$$\text{or, } s = \frac{2\sqrt{2px}}{3} \times x = \frac{2}{3} xy + C.$$

If we estimate the area from the principal vertex,  $x = 0$ ,  $y = 0$ , and  $C = 0$ ; and denoting the particular integral by  $s'$ ,  $s' = \frac{2}{3} xy$ .

That is, the area of any portion of the parabola, estimated from the vertex, is equal to  $\frac{2}{3}$  of the rectangle of the abscissa and ordinate of the extreme point. The curve is therefore quadrable.

**Quadrature of surfaces of revolution.** — The differential of a surface of revolution is equal to the circumference of a circle perpendicular to the axis into the differential of the arc of the meridian curve.

$$ds = 2\pi y \sqrt{dx^2 + dy^2};$$

in which  $y$  is the radius of a circle of the bounding surface in a plane perpendicular to the axis of revolution, and  $x$  is the abscissa, or distance of the plane from the origin of coordinate axes.

Therefore, to find the volume of any surface of revolution:

Find the value of  $y$  and  $dy$  from the equation of the meridian curve in terms of  $x$  and  $dx$ , then substitute these values in the differential equation, and integrate between the proper limits of  $x$ .

By application of this rule we may find:

The curved surface of a cylinder equals the product of the circumference of the base into the altitude.

The convex surface of a cone equals the product of the circumference of the base into half the slant height.

The surface of a sphere is equal to the area of four great circles, or equal to the curved surface of the circumscribing cylinder.

**Cubature of volumes of revolution.** — A volume of revolution is a volume generated by the revolution of a plane figure about a fixed line called the axis.

If we denote the volume by  $V$ ,  $dV = \pi y^2 dx$ .

The area of a circle described by any ordinate  $y$  is  $\pi y^2$ ; hence the differential of a volume of revolution is equal to the area of a circle perpendicular to the axis into the differential of the axis.

The differential of a volume generated by the revolution of a plane figure about the axis of  $Y$  is  $\pi x^2 dy$ .

To find the value of  $V$  for any given volume of revolution:

Find the value of  $y^2$  in terms of  $x$  from the equation of the meridian curve, substitute this value in the differential equation, and then integrate between the required limits of  $x$ .

By application of this rule we may find:

The volume of a cylinder is equal to the area of the base multiplied by the altitude.

The volume of a cone is equal to the area of the base into one third the altitude.

The volume of a prolate spheroid and of an oblate spheroid (formed by the revolution of an ellipse around its transverse and its conjugate axis respectively) are each equal to two thirds of the circumscribing cylinder.

If the axes are equal, the spheroid becomes a sphere and its volume =  $\frac{2}{3} \pi R^2 \times D = \frac{1}{6} \pi D^3$ ;  $R$  being radius and  $D$  diameter.

The volume of a paraboloid is equal to half the cylinder having the same base and altitude.

The volume of a pyramid equals the area of the base multiplied by one third the altitude.

**Second, third, etc., differentials.** — The differential coefficient being a function of the independent variable, it may be differentiated, and we thus obtain the second differential coefficient:

$d\left(\frac{du}{dx}\right) = \frac{d^2u}{dx^2}$ . Dividing by  $dx$ , we have for the second differential coefficient  $\frac{d^2u}{dx^2}$ , which is read: second differential of  $u$  divided by the square of the differential of  $x$  (or  $dx$  squared).

The third differential coefficient  $\frac{d^3u}{dx^3}$  is read: third differential of  $u$  divided by  $dx$  cubed.

The differentials of the different orders are obtained by multiplying the differential coefficient by the corresponding powers of  $dx$ ; thus  $\frac{d^3u}{dx^3} dx^3 =$  third differential of  $u$ .

**Sign of the first differential coefficient.** — If we have a curve whose equation is  $y = fx$ , referred to rectangular coördinates, the curve will recede from the axis of  $X$  when  $\frac{dy}{dx}$  is positive, and approach the axis when it is negative, when the curve lies within the first angle of the coördinate axes. For all angles and every relation of  $y$  and  $x$  the curve will recede from the axis of  $X$  when the ordinate and first differential coefficient have the same sign, and approach it when they have different signs. If the tangent of the curve becomes parallel to the axis of  $X$  at any point  $\frac{dy}{dx} = 0$ . If the tangent becomes perpendicular to the axis of  $X$  at any point  $\frac{dy}{dx} = \infty$ .

**Sign of the second differential coefficient.** — The second differential coefficient has the same sign as the ordinate when the curve is convex toward the axis of abscissa and a contrary sign when it is concave.

**Maclaurin's Theorem.** — For developing into a series any function of a single variable as  $u = A + Bx + Cx^2 + Dx^3 + Ex^4$ , etc., in which  $A, B, C$ , etc., are independent of  $x$ :

$$u = (u)_{x=0} + \left(\frac{du}{dx}\right)_{x=0} x + \frac{1}{1 \cdot 2} \left(\frac{d^2u}{dx^2}\right)_{x=0} x^2 + \frac{1}{1 \cdot 2 \cdot 3} \left(\frac{d^3u}{dx^3}\right)_{x=0} x^3 + \text{etc.}$$

In applying the formula, omit the expressions  $x = 0$ , although the coefficients are always found under this hypothesis.

EXAMPLES:

$$(a + x)^m = a^m + ma^{m-1}x + \frac{m(m-1)}{1 \cdot 2} a^{m-2}x^2 + \frac{m(m-1)(m-2)}{1 \cdot 2 \cdot 3} a^{m-3}x^3 + \text{etc.}$$

$$\frac{1}{a+x} = \frac{1}{a} - \frac{x}{a^2} + \frac{x^2}{a^3} - \frac{x^3}{a^4} + \dots - \frac{x^n}{a^{n+1}}, \text{etc.}$$

**Taylor's Theorem.** — For developing into a series any function of the sum or difference of two independent variables, as  $u' = f(x \pm y)$ :

$$u' = u + \frac{du}{dx} y + \frac{d^2u}{dx^2} \frac{y^2}{1 \cdot 2} + \frac{d^3u}{dx^3} \frac{y^3}{1 \cdot 2 \cdot 3} + \text{etc.},$$

in which  $u$  is what  $u'$  becomes when  $y = 0$ ,  $\frac{du}{dx}$  is what  $\frac{du'}{dx}$  becomes when  $y = 0$ , etc.

**Maxima and minima.** — To find the maximum or minimum value of a function of a single variable:

1. Find the first differential coefficient of the function, place it equal to 0, and determine the roots of the equation.
2. Find the second differential coefficient, and substitute each real root,



in succession, for the variable in the second member of the equation. Each root which gives a negative result will correspond to a maximum value of the function, and each which gives a positive result will correspond to a minimum value.

EXAMPLE. — To find the value of  $x$  which will render the function  $y$  a maximum or minimum in the equation of the circle,  $y^2 + x^2 = R^2$ ;

$$\frac{dy}{dx} = -\frac{x}{y}; \text{ making } -\frac{x}{y} = 0 \text{ gives } x = 0.$$

The second differential coefficient is:  $\frac{d^2y}{dx^2} = -\frac{x^2 + y^2}{y^3}$ .

When  $x = 0, y = R$ ; hence  $\frac{d^2y}{dx^2} = -\frac{1}{R}$ , which being negative,  $y$  is a maximum for  $R$  positive.

In applying the rule to practical examples we first find an expression for the function which is to be made a maximum or minimum.

2. If in such expression a constant quantity is found as a factor, it may be omitted in the operation; for the product will be a maximum or a minimum when the variable factor is a maximum or a minimum.

3. Any value of the independent variable which renders a function a maximum or a minimum will render any power or root of that function a maximum or minimum; hence we may square both members of an equation to free it of radicals before differentiating.

By these rules we may find:

The maximum rectangle which can be inscribed in a triangle is one whose altitude is half the altitude of the triangle.

The altitude of the maximum cylinder which can be inscribed in a cone is one third the altitude of the cone.

The surface of a cylindrical vessel of a given volume, open at the top, is a minimum when the altitude equals half the diameter.

The altitude of a cylinder inscribed in a sphere when its convex surface is a maximum is  $r\sqrt{2}$ .  $r =$  radius.

The altitude of a cylinder inscribed in a sphere when the volume is a maximum is  $2r \div \sqrt{3}$ .

**Maxima and Minima without the Calculus.** — In the equation  $y = a + bx + cx^2$ , in which  $a, b$ , and  $c$  are constants, either positive or negative, if  $c$  be positive  $y$  is a minimum when  $x = -b \div 2c$ ; if  $c$  be negative  $y$  is a maximum when  $x = -b \div 2c$ . In the equation  $y = a + bx + c/x$ ,  $y$  is a minimum when  $bx = c/x$ .

APPLICATION. — The cost of electrical transmission is made up (1) of fixed charges, such as superintendence, repairs, cost of poles, etc., which may be represented by  $a$ ; (2) of interest on cost of the wire, which varies with the sectional area, and may be represented by  $bx$ ; and (3) of cost of the energy wasted in transmission, which varies inversely with the area of the wire, or  $c/x$ . The total cost,  $y = a + bx + c/x$ , is a minimum when item 2 = item 3, or  $bx = c/x$ .

**Differential of an exponential function.**

$$\text{If } u = a^x \dots \dots \dots (1)$$

$$\text{then } du = da^x = a^x k dx \dots \dots \dots (2)$$

in which  $k$  is a constant dependent on  $a$ .

The relation between  $a$  and  $k$  is  $a^{\frac{1}{k}} = e$ ; whence  $a = e^k \dots \dots \dots (3)$  in which  $e = 2.7182818 \dots$  the base of the Naperian system of logarithms.

**Logarithms.** — The logarithms in the Naperian system are denoted by  $i$ , Nap. log or hyperbolic log, hyp. log, or  $\log_e$ ; and in the common system always by log.

$$k = \text{Nap. log } a; \log a = k \log e \dots \dots \dots (4)$$

The common logarithm of  $e$ ,  $= \log 2.7182818 \dots = 0.4342945 \dots$ , is called the modulus of the common system, and is denoted by  $M$ . Hence, if we have the Napierian logarithm of a number we can find the common logarithm of the same number by multiplying by the modulus. Reciprocally, Nap. log  $=$  com. log  $\times 2.3025851$ .

If in equation (4) we make  $a = 10$ , we have

$$1 = k \log e, \text{ or } \frac{1}{k} = \log e = M.$$

That is, the modulus of the common system is equal to 1, divided by the Napierian logarithm of the common base.

From equation (2) we have

$$\frac{du}{u} = \frac{da^x}{a^x} = k dx.$$

If we make  $a = 10$ , the base of the common system,  $x = \log u$ , and

$$d(\log u) = dx = \frac{du}{u} \times \frac{1}{k} = \frac{du}{u} \times M.$$

That is, the differential of a common logarithm of a quantity is equal to the differential of the quantity divided by the quantity, into the modulus.

If we make  $a = e$ , the base of the Napierian system,  $x$  becomes the Napierian logarithm of  $u$ , and  $k$  becomes 1 (see equation (3)); hence  $M = 1$ , and

$$d(\text{Nap. log } u) = dx = \frac{du}{a^x}; = \frac{du}{u}.$$

That is, the differential of a Napierian logarithm of a quantity is equal to the differential of the quantity divided by the quantity; and in the Napierian system the modulus is 1.

Since  $k$  is the Napierian logarithm of  $a$ ,  $du = a^x l a dx$ . That is, the differential of a function of the form  $a^x$  is equal to the function, into the Napierian logarithm of the base  $a$ , into the differential of the exponent.

If we have a differential in a fractional form, in which the numerator is the differential of the denominator, the integral is the Napierian logarithm of the denominator. Integrals of fractional differentials of other forms are given below:

**Differential forms which have known integrals; exponential functions.** ( $l = \text{Nap. log.}$ )

$$1. \quad \int a^x l a dx = a^x + C;$$

$$2. \quad \int \frac{dx}{x} = \int dx x^{-1} = lx + C;$$

$$3. \quad \int (xy^{x-1} dy + y^x l y \times dx) = y^x + C;$$

$$4. \quad \int \frac{dx}{\sqrt{x^2 \pm a^2}} = l(x + \sqrt{x^2 \pm a^2}) + C;$$

$$5. \quad \int \frac{dx}{\sqrt{x^2 \pm 2ax}} = l(x \pm a + \sqrt{x^2 \pm 2ax}) + C;$$

$$6. \quad \int \frac{2a dx}{a^2 - x^2} = l \left( \frac{a+x}{a-x} \right) + C;$$

7.  $\int \frac{2a \, dx}{x^2 - a^2} = l \left( \frac{x - a}{x + a} \right) + C;$
8.  $\int \frac{2a \, dx}{x \sqrt{a^2 + x^2}} = l \left( \frac{\sqrt{a^2 + x^2} - a}{\sqrt{a^2 + x^2} + a} \right) + C;$
9.  $\int \frac{2a \, dx}{x \sqrt{a^2 - x^2}} = l \left( \frac{a - \sqrt{a^2 - x^2}}{a + \sqrt{a^2 - x^2}} \right) + C;$
10.  $\int \frac{x^{-2} dx}{\sqrt{x + x^{-2}}} = -l \left( \frac{1 + \sqrt{1 + a^2 x^2}}{x} \right) + C.$

**Circular functions.** — Let  $z$  denote an arc in the first quadrant,  $y$  its sine,  $x$  its cosine,  $v$  its versed sine, and  $t$  its tangent; and the following notation be employed to designate an arc by any one of its functions, viz.,

$\sin^{-1} y$  denotes an arc of which  $y$  is the sine,  
 $\cos^{-1} x$     “    “    “    “    “     $x$  is the cosine,  
 $\tan^{-1} t$     “    “    “    “    “     $t$  is the tangent,

(read “arc whose sine is  $y$ ,” etc.), — we have the following differential forms which have known integrals ( $r$  = radius):

$\int \cos z \, dz = \sin z + C;$ $\int -\sin z \, dz = \cos z + C;$ $\int \frac{dy}{\sqrt{1 - y^2}} = \sin^{-1} y + C;$ $\int \frac{-dx}{\sqrt{1 - x^2}} = \cos^{-1} x + C;$ $\int \frac{dv}{\sqrt{2v - v^2}} = \text{versin}^{-1} v + C;$ $\int \frac{dt}{1 + t^2} = \tan^{-1} t + C;$ $\int \frac{r \, dy}{\sqrt{r^2 - y^2}} = \sin^{-1} y + C;$ $\int \frac{-r \, dx}{\sqrt{r^2 - x^2}} = \cos^{-1} x + C;$		$\int \sin z \, dz = \text{versin} z + C;$ $\int \frac{dz}{\cos^2 z} = \tan z + C;$ $\int \frac{r \, dv}{\sqrt{2rv + v^2}} = \text{versin}^{-1} v + C;$ $\int \frac{r^2 \, dt}{r^2 + t^2} = \tan^{-1} t + C;$ $\int \frac{du}{\sqrt{a^2 - u^2}} = \sin^{-1} \frac{u}{a} + C;$ $\int \frac{-du}{\sqrt{a^2 - u^2}} = \cos^{-1} \frac{u}{a} + C;$ $\int \frac{du}{\sqrt{2au - u^2}} = \text{versin}^{-1} \frac{u}{a} + C;$ $\int \frac{a \, du}{a^2 + u^2} = \tan^{-1} \frac{u}{a} + C.$
--	--	--

**The cycloid.** — If a circle be rolled along a straight line, any point of the circumference, as  $P$ , will describe a curve which is called a cycloid. The circle is called the generating circle, and  $P$  the generating point.

The transcendental equation of the cycloid is

$$x = \text{versin}^{-1} \frac{y}{r} - \sqrt{2ry - y^2},$$

and the differential equation is  $dx = \frac{y dx}{\sqrt{2ry - y^2}}$ .

The area of the cycloid is equal to three times the area of the generating circle.

The surface described by the arc of a cycloid when revolved about its base is equal to 64 thirds of the generating circle.

The volume of the solid generated by revolving a cycloid about its base is equal to five eighths of the circumscribing cylinder.

**Integral calculus.** — In the integral calculus we have to return from the differential to the function from which it was derived. A number of differential expressions are given above, each of which has a known integral corresponding to it, which, being differentiated, will produce the given differential.

In all classes of functions any differential expression may be integrated when it is reduced to one of the known forms; and the operations of the integral calculus consist mainly in making such transformations of given differential expressions as shall reduce them to equivalent ones whose integrals are known.

For methods of making these transformations reference must be made to the text-books on differential and integral calculus.

## THE SLIDE RULE.

The slide rule is based on the principles that the addition of logarithms multiplies the numbers which they represent, and subtracting logarithms divides the numbers. By its use the operations of multiplication, division, the finding of powers and the extraction of roots, may be performed rapidly and with an approximation to accuracy which is sufficient for many purposes. With a good 10-inch Mannheim rule the results obtained are usually accurate to  $\frac{1}{4}$  of 1 per cent. Much greater accuracy is obtained with cylindrical rules like the Thacher.

The rule (see Fig. 73) consists of a fixed and a sliding part both of which are ruled with logarithmic scales; that is, with consecutive divisions spaced not equally, as in an ordinary scale, but in proportion to the logarithms of a series of numbers from 1 to 10. By moving the slide to the right or left the logarithms are added or subtracted, and multiplication or division of the numbers thereby effected. The scales on the fixed part of the rule are known as the *A* and *D* scales, and those on the slide as the *B* and *C* scales. *A* and *B* are the upper and *C* and *D* are the lower scales. The *A* and *B* scales are each divided into two, left hand and right hand, each being a reproduction, one half the size, of the *C* and *D* scales. A "runner," which consists of a framed glass plate with a fine vertical line on it, is used to facilitate some of the operations. The numbering on each scale begins with the figure 1, which is called

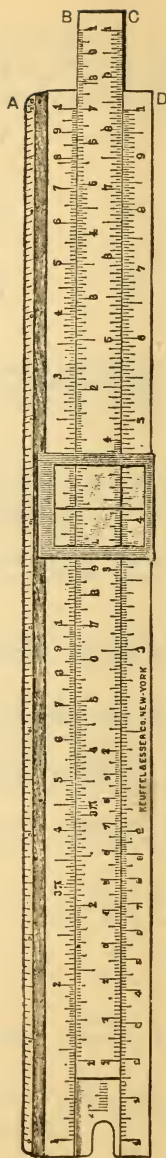

FIG. 73.



the "index" of the scale. In using the scale the figures 1, 2, 3, etc., are to be taken either as representing these numbers, or as 10, 20, 30, etc., 100, 200, 300, etc., 0.1, 0.2, 0.3, etc. that is, the numbers multiplied or divided by 10, 100, etc., as may be most convenient for the solution of a given problem.

The following examples will give an idea of the method of using the slide rule.

*Proportion.* — Set the first term of a proportion on the *C* scale opposite the second term on the *D* scale, then opposite the third term on the *C* scale read the fourth term on the *D* scale.

*EXAMPLE* — Find the fourth term in the proportion  $12 : 21 :: 30 : x$ . Move the slide to the right until 12 on *C* coincides with 21 on *D*, then opposite 30 on *C* read  $x$  on *D* = 52.5. The *A* and *B* scales may be used instead of *C* and *D*.

*Multiplication.* — Set the index or figure 1 of the *C* scale to one of the factors on *D*

*EXAMPLE.* —  $25 \times 3$ . Move the slide to the right until the left index of *C* coincides with 25 on the *D* scale. Under 3 on the *C* scale will be found the product on the *D* scale, = 75.

*Division.* — Place the divisor on *C* opposite the dividend on *D*, and the quotient will be found on *D* under the index of *C*.

*EXAMPLE.* —  $750 \div 25$ . Move the slide to the right until 25 on *C* coincides with 750 on *D*. Under the left index of *C* is found the quotient on *D*, = 30.

*Combined Multiplication and Division.* — Arrange the factors to be multiplied and divided in the form of a fraction with one more factor in the numerator than in the denominator, supplying the factor 1 if necessary. Then perform alternate division and multiplication, using the runner to indicate the several partial results.

*EXAMPLE* —  $\frac{4 \times 5 \times 8}{3 \times 6} = 8.9$  nearly. Set 3 on *C* over 4 on *D*, set runner to 5 on *C*, then set 6 on *C* under the runner, and read under 8 on *C* the result 8.9 — on *D*.

*Involution and Evolution.* — The numbers on scales *A* and *B* are the squares of their coinciding numbers on the scales *C* and *D*, and also the numbers on scales *C* and *D* are the square roots of their coinciding numbers on scales *A* and *B*.

*EXAMPLE* —  $4^2 = 16$ . Set the runner over 4 on scale *D* and read 16 on *A*.

$\sqrt{16} = 4$ . Set the runner over 16 on *A* and read 4 on *D*.

In extracting square roots, if the number of digits is odd, take the number on the left-hand scale of *A*; if the number of digits is even, take the number on the right-hand scale of *A*.

To cube a number, perform the operations of squaring and multiplication.

*EXAMPLE* —  $2^3 = 8$ . Set the index of *C* over 2 on *D*, and above 2 on *B* read the result 8 on *A*.

*Extraction of the Cube Root.* — Set the runner over the number on *A*, then move the slide until there is found under the runner on *B*, the same number which is found under the index of *C* on *D*; this number is the cube root desired.

*EXAMPLE* —  $\sqrt[3]{8} = 2$ . Set the runner over 8 on *A*, move the slide along until the same number appears under the runner on *B* and under the index of *C* on *D*; this will be the number 2.

*Trigonometrical Computations.* — On the under side of the slide (which is reversible) are placed three scales, a scale of natural sines marked *S*, a scale of natural tangents marked *T*, and between these a scale of equal parts. To use these scales, reverse the slide, bringing its under side to the top. Coinciding with an angle on *S* its sine will be found on *A*, and coinciding with an angle on *T* will be found the tangent on *D*. Sines and tangents can be multiplied or divided like numbers.

## LOGARITHMIC RULED PAPER.

W. F. Durand (*Eng. News*, Sept. 28, 1893.)

As plotted on ordinary cross-section paper the lines which express relations between two variables are usually curved, and must be plotted point by point from a table previously computed. It is only where the exponents involved in the relationship are unity that the line becomes straight and may be drawn immediately on the determination of two of its points. It is the peculiar property of logarithmic section paper that for all relationships which involve multiplication, division, raising to powers, or extraction of roots, the lines representing them are straight. Any such relationship may be represented by an equation of the form:  $y = Bx^n$ . Taking logarithms we have:  $\log y = \log B + n \log x$ .

Logarithmic section paper is a short and ready means of plotting such logarithmic equations. The scales on each side are logarithmic instead of uniform, as in ordinary cross-section paper. The numbers and divisions marked are placed at such points that their distances from the origin are proportional to the logarithms of such numbers instead of to the numbers themselves. If we take any point, as 3, for example, on such a scale, the real distance we are dealing with is  $\log 3$  to some particular base, and not 3 itself. The number at the origin of such a scale is always 1 and not 0, because 1 is the number whose logarithm is 0. This 1 may, however, represent a unit of any order, so that quantities of any size whatever may be dealt with.

If we have a series of values of  $x$  and of  $Bx^n$ , and plot on logarithmic section paper  $x$  horizontally and  $Bx^n$  vertically, the actual distances involved will be  $\log x$  and  $\log (Bx^n)$ , or  $\log B + n \log x$ . But these distances will give a straight line as the locus. Hence all relationships expressible in this form are represented on logarithmic section paper by straight lines. It follows that the entire locus may be determined from any two points; that is, from any two values of  $Bx^n$ ; or, again, by any one point and the angle of inclination; that is, by one value of  $Bx^n$  and the value of  $n$ , remembering that  $n$  is the tangent of the angle of inclination to the horizontal.

A single square plotted on each edge with a logarithmic scale from 1 to 10 may be made to serve for any number whatever from 0 to  $\infty$ . Thus to express graphically the locus of the equation:  $y = x^{3/2}$ . Let Fig. 74 denote a square cross-sectioned with logarithmic scales, as described. Suppose that there were joined to it and to each other on the right and above, an indefinite series of such squares similarly divided. Then, considering, in passing from one square to an adjacent one to the right or above, that the unit becomes of next higher order, such a series of squares would, with the proper variation of the unit, represent all values of either  $x$  or  $y$  between 0 and  $\infty$ .

Suppose the original square divided on the horizontal edge into 3 parts, and on the vertical edge into 2 parts, the points of division being at A, B, D, F, G, I. Then lines joining these points, as shown, will be at an inclination to the horizontal whose tangent is  $3/2$ . Now, beginning at O, OF will give the value of  $x^{3/2}$  for values of  $x$  from 1 to that denoted by HF, or OB, or about 4.6. For greater values of  $x$  the line would run into the adjacent square above, but the location of this line, if continued, would be exactly similar to that of BD in the square before us. Therefore the line BD will give values of  $x^{3/2}$  for  $x$  between B and C, or 4.6 and 10, the corresponding values of  $y$  being of the order of tens, and ranging from 10 to 31.3. For larger values of  $x$  the unit of  $x$  is of the higher order, and we run into an adjacent square to the right without change of unit for  $y$ . In this square we should traverse a line similar to IG. Therefore, by a proper choice of units we may make use of IG for the determination of values of  $x^{3/2}$  where  $x$  lies between 10 and the value at G, or about 21.5. We should then run into an adjacent square above, requiring the unit on  $y$  to be of the next higher order, and traverse a line similar to AE, which

takes us finally to the opposite corner and completes the cycle. Following this, the same series of lines would result for numbers of succeeding orders.

The value of  $x^{3/2}$  for any value of  $x$  between 1 and  $\infty$  may thus be read from one or another of these lines, and likewise for any value between 0 and 1. The location of the decimal point is readily found by a little attention to the numbers involved. The limiting values of  $x$  for any given line may be marked on it, thus enabling a proper choice to be readily made. Thus, in Fig. 74 we mark  $OF$  as 0 - 4.6,  $BD$  as 4.6 - 10,  $IG$  as

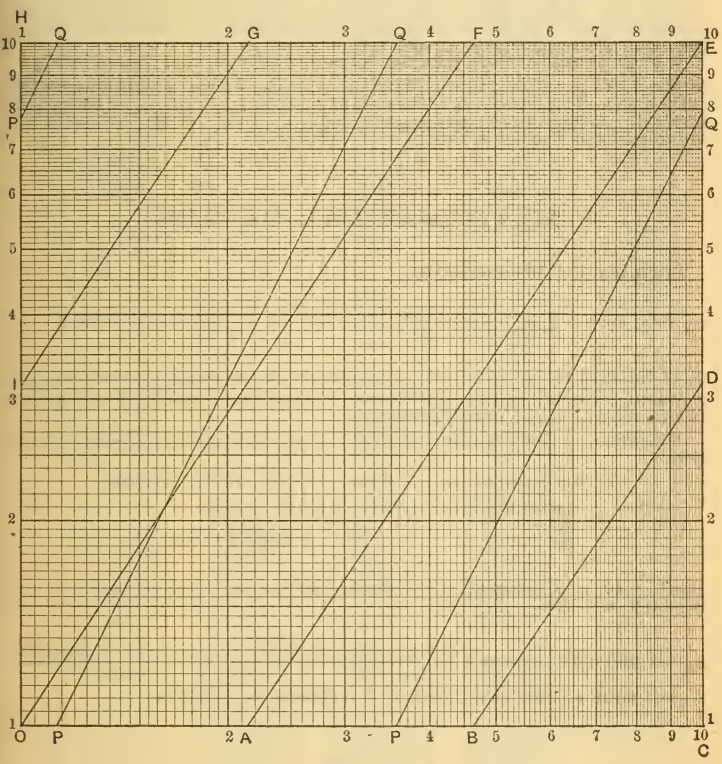

FIG. 74.

10 - 21.5, and  $AE$  as 21.5 - 100. If values of  $x$  less than 1 are to be dealt with,  $AE$  will serve for values of  $x$  between 1 and 0.215,  $IG$  for values between 0.215 and 0.1,  $BD$  for values between 0.1 and 0.046, and  $OF$  for values between 0.046 and 0.001.

The principles involved in this case may be readily extended to any other, and in general if the exponent be represented by  $m/n$ , the complete set of lines may be drawn by dividing one side of the square into  $m$  and the other into  $n$  parts, and joining the points of division as in Fig. 74. In all there will be  $(m + n - 1)$  lines, and opposite to any point on  $X$  there will be  $n$  lines corresponding to the  $n$  different beginnings of the  $n$ th root

of the  $m$ th power, while opposite to any point on  $Y$  will be  $m$  lines corresponding to the different beginnings of the  $m$ th root of the  $n$ th power. Where the complete number of lines would be quite large, it is usually unnecessary to draw them all, and the number may be limited to those necessary to cover the needed range in the values of  $x$ .

If, instead of the equation  $y = x^n$ , we have a constant term as a multiplier, giving an equation in the more general form  $y = Bx^n$ , or  $Bx^{m/n}$ , there will be the same number of lines and at the same inclination, but all shifted vertically through a distance equal to  $\log B$ . If, therefore, we start on the axis of  $Y$  at the point  $B$ , we may draw in the same series of lines and in a similar manner. In this way  $PQ$  represents the locus giving the values of the areas of circles in terms of their diameters, being the locus of the equation  $A = \frac{1}{4} \pi d^2$  or  $y = \frac{1}{4} \pi x^2$ .

If in any case we have  $x$  in the denominator such that the equation is in the form  $y = B/x^n$ , this is equal to  $y = Bx^{-n}$ , and the same general rules hold. The lines in such case slant downward to the right instead of upward. Logarithmic ruled paper, with directions for the use, may be obtained from Keuffel & Esser Co., 127 Fulton St., New York.

## MATHEMATICAL TABLES.

### Formula for Interpolation.

$$a_n = a_1 + (n - 1)d_1 + \frac{(n - 1)(n - 2)}{1 \cdot 2} d_2 + \frac{(n - 1)(n - 2)(n - 3)}{1 \cdot 2 \cdot 3} d_3 + \dots$$

$a_1$  = the first term of the series;  $n$ , number of the required term;  $a_n$ , the required term;  $d_1, d_2, d_3$ , first terms of successive orders of differences between  $a_1, a_2, a_3, a_4$ , successive terms.

EXAMPLE. — Required the log of 40.7, logs of 40, 41, 42, 43 being given as below.

Terms $a_1, a_2, a_3, a_4$ :	1.6021	1.6128	1.6232	1.6335
1st differences:	0.0107	0.0104	0.0103	
2d	"	- 0.0003	- 0.0001	
3d	"		+ 0.0002	

For log. 40,  $n = 1$ ; log 41,  $n = 2$ ; for log 40.7,  $n = 1.7$ ;  $n - 1 = 0.7$ ;  $n - 2 = - 0.3$ ;  $n - 3 = - 1.3$ .

$$\begin{aligned} a_n &= 1.6021 + 0.7(0.0107) + \frac{(0.7)(-0.3)(-0.0003)}{2} + \frac{(0.7)(-0.3)(-1.3)(0.0002)}{6} \\ &= 1.6021 + 0.00749 + 0.000031 + 0.000009 = 1.6096 +. \end{aligned}$$



RECIPROCAL OF NUMBERS.

No.	Reciprocal.	No.	Reciprocal.	No.	Reciprocal.	No.	Reciprocal.	No.	Reciprocal.
1	.00000000	64	.01562500	127	.00787402	190	.00526316	253	.00395257
2	.50000000	5	.01538461	8	.00781250	1	.00523560	4	.00393701
3	.33333333	6	.01515151	9	.00775194	2	.00520833	5	.00392157
4	.25000000	7	.01492537	130	.00769231	3	.00518135	6	.00390625
5	.20000000	8	.01470588	1	.00763359	4	.00515464	7	.00389105
6	.16666667	9	.01449275	2	.00757576	5	.00512820	8	.00387597
7	.14285714	70	.01428571	3	.00751880	6	.00510204	9	.00386100
8	.12500000	1	.01408451	4	.00746269	7	.00507614	260	.00384615
9	.11111111	2	.01388889	5	.00740741	8	.00505051	1	.00383142
10	.10000000	3	.01369863	6	.00735294	9	.00502513	2	.00381679
11	.09090909	4	.01351351	7	.00729927	200	.00500000	3	.00380228
12	.08333333	5	.01333333	8	.00724638	1	.00497512	4	.00378788
13	.07692308	6	.01315789	9	.00719424	2	.00495049	5	.00377358
14	.07142857	7	.01298701	140	.00714286	3	.00492611	6	.00375940
15	.06666667	8	.01282051	1	.00709220	4	.00490196	7	.00374532
16	.06250000	9	.01265823	2	.00704225	5	.00487805	8	.00373134
17	.05882353	80	.01250000	3	.00699301	6	.00485437	9	.00371747
18	.05555556	1	.01234568	4	.00694444	7	.00483092	270	.00370370
19	.05263158	2	.01219512	5	.00689655	8	.00480769	1	.00369004
20	.05000000	3	.01204819	6	.00684931	9	.00478469	2	.00367647
1	.04761905	4	.01190476	7	.00680272	210	.00476190	3	.00366300
2	.04545455	5	.01176471	8	.00675676	11	.00473934	4	.00364963
3	.04347826	6	.01162791	9	.00671141	12	.00471698	5	.00363636
4	.04166667	7	.01149425	150	.00666667	13	.00469484	6	.00362319
5	.04000000	8	.01136364	1	.00662252	14	.00467290	7	.00361011
6	.03846154	9	.01123595	2	.00657895	15	.00465116	8	.00359712
7	.03703704	90	.01111111	3	.00653595	16	.00462963	9	.00358423
8	.03571429	1	.01098901	4	.00649351	17	.00460829	280	.00357143
9	.03448276	2	.01086956	5	.00645161	18	.00458716	1	.00355872
30	.03333333	3	.01075269	6	.00641026	19	.00456621	2	.00354610
1	.03225806	4	.01063830	7	.00636943	220	.00454545	3	.00353357
2	.03125000	5	.01052632	8	.00632911	1	.00452489	4	.00352113
3	.03030303	6	.01041667	9	.00628931	2	.00450450	5	.00350877
4	.02941176	7	.01030928	160	.00625000	3	.00448430	6	.00349650
5	.02857143	8	.01020498	1	.00621118	4	.00446429	7	.00348432
6	.02777778	9	.01010101	2	.00617284	5	.00444444	8	.00347222
7	.02702703	100	.01000000	3	.00613497	6	.00442478	9	.00346021
8	.02631579	1	.00990099	4	.00609756	7	.00440529	290	.00344828
9	.02564103	2	.00980392	5	.00606061	8	.00438596	1	.00343643
40	.02500000	3	.00970874	6	.00602410	9	.00436681	2	.00342466
1	.02439024	4	.00961538	7	.00598802	230	.00434783	3	.00341297
2	.02380952	5	.00952381	8	.00595238	1	.00432900	4	.00340136
3	.02325581	6	.00943396	9	.00591716	2	.00431034	5	.00338983
4	.02272727	7	.00934579	170	.00588235	3	.00429184	6	.00337838
5	.02222222	8	.00925926	1	.00584795	4	.00427350	7	.00336700
6	.02173913	9	.00917431	2	.00581395	5	.00425532	8	.00335570
7	.02127660	110	.00909091	3	.00578035	6	.00423729	9	.00334448
8	.02083333	11	.00900901	4	.00574713	7	.00421941	300	.00333333
9	.02040816	12	.00892857	5	.00571429	8	.00420168	1	.00332226
50	.02000000	13	.00884956	6	.00568182	9	.00418410	2	.00331126
1	.01960784	14	.00877193	7	.00564972	240	.00416667	3	.00330033
2	.01923077	15	.00869565	8	.00561798	1	.00414938	4	.00328947
3	.01886792	16	.00862069	9	.00558659	2	.00413223	5	.00327869
4	.01851852	17	.00854701	180	.00555556	3	.00411523	6	.00326797
5	.01818182	18	.00847458	1	.00552486	4	.00409836	7	.00325733
6	.01785714	19	.00840336	2	.00549451	5	.00408163	8	.00324675
7	.01754386	120	.00833333	3	.00546448	6	.00406504	9	.00323625
8	.01724138	1	.00826446	4	.00543478	7	.00404858	310	.00322581
9	.01694915	2	.00819672	5	.00540540	8	.00403226	11	.00321543
60	.01666667	3	.00813008	6	.00537634	9	.00401606	12	.00320513
1	.01639344	4	.00806452	7	.00534759	250	.00400000	13	.00319489
2	.01612903	5	.00800000	8	.00531914	1	.00398406	14	.00318471
3	.01587302	6	.00793651	9	.00529100	2	.00396825	15	.00317460

No.	Reciprocal.	No.	Reciprocal.	No.	Reciprocal.	No.	Reciprocal.	No.	Reciprocal.
316	.00316456	381	.00262467	446	.00224215	511	.00195695	576	.00173611
17	.00315457	2	.00261780	7	.00223714	12	.00195312	7	.00173310
18	.00314465	3	.00261097	8	.00223214	13	.00194932	8	.00173010
19	.00313480	4	.00260417	9	.00222717	14	.00194552	9	.00172712
320	.00312500	5	.00259740	450	.00222222	15	.00194175	580	.00172414
1	.00311526	6	.00259067	1	.00221729	16	.00193798	1	.00172117
2	.00310559	7	.00258398	2	.00221239	17	.00193424	2	.00171821
3	.00309597	8	.00257732	3	.00220751	18	.00193050	3	.00171527
4	.00308642	9	.00257069	4	.00220264	19	.00192678	4	.00171233
5	.00307692	390	.00256410	5	.00219780	520	.00192308	5	.00170940
6	.00306748	1	.00255754	6	.00219298	1	.00191939	6	.00170648
7	.00305810	2	.00255102	7	.00218818	2	.00191571	7	.00170358
8	.00304878	3	.00254453	8	.00218341	3	.00191205	8	.00170068
9	.00303951	4	.00253807	9	.00217865	4	.00190840	9	.00169779
330	.00303030	5	.00253165	460	.00217391	5	.00190476	590	.00169491
1	.00302115	6	.00252525	1	.00216920	6	.00190114	1	.00169205
2	.00301205	7	.00251889	2	.00216450	7	.00189753	2	.00168919
3	.00300300	8	.00251256	3	.00215983	8	.00189394	3	.00168634
4	.00299401	9	.00250627	4	.00215517	9	.00189036	4	.00168350
5	.00298507	400	.00250000	5	.00215054	530	.00188679	5	.00168067
6	.00297619	1	.00249377	6	.00214592	1	.00188324	6	.00167785
7	.00296736	2	.00248756	7	.00214133	2	.00187970	7	.00167504
8	.00295858	3	.00248139	8	.00213675	3	.00187617	8	.00167224
9	.00294985	4	.00247525	9	.00213220	4	.00187266	9	.00166945
340	.00294118	5	.00246914	470	.00212766	5	.00186916	600	.00166667
1	.00293255	6	.00246305	1	.00212314	6	.00186567	1	.00166389
2	.00292398	7	.00245700	2	.00211864	7	.00186220	2	.00166113
3	.00291545	8	.00245098	3	.00211416	8	.00185874	3	.00165837
4	.00290698	9	.00244499	4	.00210970	9	.00185528	4	.00165563
5	.00289855	410	.00243902	5	.00210526	540	.00185185	5	.00165289
6	.00289017	11	.00243309	6	.00210084	1	.00184843	6	.00165016
7	.00288184	12	.00242718	7	.00209644	2	.00184502	7	.00164745
8	.00287356	13	.00242131	8	.00209205	3	.00184162	8	.00164474
9	.00286533	14	.00241546	9	.00208768	4	.00183823	9	.00164204
350	.00285714	15	.00240964	480	.00208333	5	.00183486	610	.00163934
1	.00284900	16	.00240385	1	.00207900	6	.00183150	11	.00163666
2	.00284091	17	.00239808	2	.00207469	7	.00182815	12	.00163399
3	.00283286	18	.00239234	3	.00207039	8	.00182482	13	.00163132
4	.00282486	19	.00238663	4	.00206612	9	.00182149	14	.00162866
5	.00281690	420	.00238095	5	.00206186	550	.00181818	15	.00162602
6	.00280899	1	.00237530	6	.00205761	1	.00181488	16	.00162338
7	.00280112	2	.00236967	7	.00205339	2	.00181159	17	.00162075
8	.00279330	3	.00236407	8	.00204918	3	.00180832	18	.00161812
9	.00278551	4	.00235849	9	.00204499	4	.00180505	19	.00161551
360	.00277778	5	.00235294	490	.00204082	5	.00180180	620	.00161290
1	.00277008	6	.00234742	1	.00203666	6	.00179856	1	.00161031
2	.00276243	7	.00234192	2	.00203252	7	.00179533	2	.00160772
3	.00275482	8	.00233645	3	.00202840	8	.00179211	3	.00160514
4	.00274725	9	.00233100	4	.00202429	9	.00178891	4	.00160256
5	.00273973	430	.00232558	5	.00202020	560	.00178571	5	.00160000
6	.00273224	1	.00232019	6	.00201613	1	.00178253	6	.00159744
7	.00272480	2	.00231481	7	.00201207	2	.00177936	7	.00159490
8	.00271739	3	.00230947	8	.00200803	3	.00177620	8	.00159236
9	.00271003	4	.00230415	9	.00200401	4	.00177305	9	.00158982
370	.00270270	5	.00229885	500	.00200000	5	.00176991	630	.00158730
1	.00269542	6	.00229358	1	.00199601	6	.00176678	1	.00158479
2	.00268817	7	.00228833	2	.00199203	7	.00176367	2	.00158228
3	.00268096	8	.00228310	3	.00198807	8	.00176056	3	.00157978
4	.00267380	9	.00227790	4	.00198413	9	.00175747	4	.00157729
5	.00266667	440	.00227273	5	.00198020	570	.00175439	5	.00157480
6	.00265957	1	.00226757	6	.00197628	1	.00175131	6	.00157233
7	.00265252	2	.00226244	7	.00197239	2	.00174825	7	.00156986
8	.00264550	3	.00225734	8	.00196850	3	.00174520	8	.00156740
9	.00263852	4	.00225225	9	.00196464	4	.00174216	9	.00156494
380	.00263158	5	.00224719	510	.00196078	5	.00173913	640	.00156250

No.	Reciprocal.	No.	Reciprocal.	No.	Reciprocal.	No.	Reciprocal.	No.	Reciprocal.
641	.00156006	706	.00141643	771	.00129702	836	.00119617	901	.00110988
2	.00155763	7	.00141443	2	.00129534	7	.00119474	2	.00110865
3	.00155521	8	.00141243	3	.00129366	8	.00119332	3	.00110742
4	.00155279	9	.00141044	4	.00129199	9	.00119189	4	.00110619
5	.00155039	710	.00140845	5	.00129032	840	.00119048	5	.00110497
6	.00154799	11	.00140647	6	.00128866	1	.00118906	6	.00110375
7	.00154559	12	.00140449	7	.00128700	2	.00118765	7	.00110254
8	.00154321	13	.00140252	8	.00128535	3	.00118624	8	.00110132
9	.00154083	14	.00140056	9	.00128370	4	.00118483	9	.00110011
650	.00153846	15	.00139860	780	.00128205	5	.00118343	910	.00109890
1	.00153610	16	.00139665	1	.00128041	6	.00118203	11	.00109769
2	.00153374	17	.00139470	2	.00127877	7	.00118064	12	.00109649
3	.00153140	18	.00139276	3	.00127714	8	.00117924	13	.00109529
4	.00152905	19	.00139032	4	.00127551	9	.00117786	14	.00109409
5	.00152672	720	.00138839	5	.00127388	850	.00117647	15	.00109290
6	.00152439	1	.00138696	6	.00127226	1	.00117509	16	.00109170
7	.00152207	2	.00138504	7	.00127065	2	.00117371	17	.00109051
8	.00151975	3	.00138313	8	.00126904	3	.00117233	18	.00108932
9	.00151745	4	.00138121	9	.00126743	4	.00117096	19	.00108814
660	.00151515	5	.00137931	790	.00126582	5	.00116959	920	.00108696
1	.00151286	6	.00137741	1	.00126422	6	.00116822	1	.00108578
2	.00151057	7	.00137552	2	.00126263	7	.00116686	2	.00108460
3	.00150830	8	.00137363	3	.00126103	8	.00116550	3	.00108342
4	.00150502	9	.00137174	4	.00125945	9	.00116414	4	.00108225
5	.00150376	730	.00136936	5	.00125786	860	.00116279	5	.00108108
6	.00150150	1	.00136799	6	.00125628	1	.00116144	6	.00107991
7	.00149925	2	.00136612	7	.00125470	2	.00116009	7	.00107875
8	.00149701	3	.00136426	8	.00125313	3	.00115875	8	.00107759
9	.00149477	4	.00136240	9	.00125156	4	.00115741	9	.00107643
670	.00149254	5	.00136054	800	.00125000	5	.00115607	930	.00107527
1	.00149031	6	.00135870	1	.00124844	6	.00115473	1	.00107411
2	.00148809	7	.00135685	2	.00124688	7	.00115340	2	.00107296
3	.00148588	8	.00135501	3	.00124533	8	.00115207	3	.00107181
4	.00148368	9	.00135318	4	.00124378	9	.00115075	4	.00107066
5	.00148148	740	.00135135	5	.00124224	870	.00114942	5	.00106952
6	.00147929	1	.00134953	6	.00124069	1	.00114811	6	.00106838
7	.00147710	2	.00134771	7	.00123916	2	.00114679	7	.00106724
8	.00147493	3	.00134589	8	.00123762	3	.00114547	8	.00106610
9	.00147275	4	.00134409	9	.00123609	4	.00114416	9	.00106496
680	.00147059	5	.00134228	810	.00123457	5	.00114286	940	.00106383
1	.00146843	6	.00134048	11	.00123305	6	.00114155	1	.00106270
2	.00146628	7	.00133869	12	.00123153	7	.00114025	2	.00106157
3	.00146413	8	.00133690	13	.00123001	8	.00113895	3	.00106044
4	.00146199	9	.00133511	14	.00122850	9	.00113766	4	.00105932
5	.00145985	750	.00133333	15	.00122699	890	.00113636	5	.00105820
6	.00145773	1	.00133156	16	.00122549	1	.00113507	6	.00105708
7	.00145560	2	.00132979	17	.00122399	2	.00113379	7	.00105597
8	.00145349	3	.00132802	18	.00122249	3	.00113250	8	.00105485
9	.00145137	4	.00132626	19	.00122100	4	.00113122	9	.00105374
690	.00144927	5	.00132450	820	.00121951	5	.00112994	950	.00105263
1	.00144718	6	.00132275	1	.00121803	6	.00112867	1	.00105152
2	.00144509	7	.00132100	2	.00121654	7	.00112740	2	.00105042
3	.00144300	8	.00131926	3	.00121507	8	.00112613	3	.00104932
4	.00144092	9	.00131752	4	.00121359	9	.00112486	4	.00104822
5	.00143885	760	.00131579	5	.00121212	890	.00112360	5	.00104712
6	.00143678	1	.00131406	6	.00121065	1	.00112233	6	.00104602
7	.00143472	2	.00131234	7	.00120919	2	.00112108	7	.00104493
8	.00143266	3	.00131062	8	.00120773	3	.00111982	8	.00104384
9	.00143061	4	.00130890	9	.00120627	4	.00111857	9	.00104275
700	.00142857	5	.00130719	830	.00120482	5	.00111732	960	.00104167
1	.00142653	6	.00130548	1	.00120337	6	.00111607	1	.00104058
2	.00142450	7	.00130378	2	.00120192	7	.00111483	2	.00103950
3	.00142247	8	.00130208	3	.00120048	8	.00111359	3	.00103842
4	.00142045	9	.00130039	4	.00119904	9	.00111235	4	.00103734
5	.00141844	770	.00129870	5	.00119760	900	.00111111	5	.00103627



No.	Reciprocal.	No.	Reciprocal.	No.	Reciprocal.	No.	Reciprocal.	No.	Reciprocal.
966	.00103520	1031	.000969932	1096	.000912409	1161	.000861326	1226	.000815661
7	.00103413	2	.000968992	7	.000911577	2	.000860585	7	.000814996
8	.00103306	3	.000968054	8	.000910747	3	.000859845	8	.000814332
9	.00103199	4	.000967118	9	.000909918	4	.000859106	9	.000813670
970	.00103093	5	.000966184	1100	.000909091	5	.000858369	1230	.000813008
1	.00102937	6	.000965251	1	.000908265	6	.000857633	1	.000812348
2	.00102831	7	.000964320	2	.000907441	7	.000856898	2	.000811688
3	.00102775	8	.000963391	3	.000906618	8	.000856164	3	.000811030
4	.00102669	9	.000962464	4	.000905797	9	.000855432	4	.000810373
5	.00102564	1040	.000961538	5	.000904977	1170	.000854701	5	.000809717
6	.00102459	1	.000960615	6	.000904159	1	.000853971	6	.000809061
7	.00102354	2	.000959693	7	.000903342	2	.000853242	7	.000808407
8	.00102250	3	.000958774	8	.000902527	3	.000852515	8	.000807754
9	.00102145	4	.000957854	9	.000901713	4	.000851789	9	.000807102
980	.00102041	5	.000956938	1110	.000900901	5	.000851064	1240	.000806452
1	.00101937	6	.000956023	11	.000900090	6	.000850340	1	.000805802
2	.00101833	7	.000955110	12	.000899281	7	.000849618	2	.000805153
3	.00101729	8	.000954198	13	.000898473	8	.000848896	3	.000804505
4	.00101626	9	.000953289	14	.000897666	9	.000848176	4	.000803858
5	.00101523	1050	.000952381	15	.000896861	1180	.000847457	5	.000803213
6	.00101420	1	.000951475	16	.000896057	1	.000846740	6	.000802568
7	.00101317	2	.000950570	17	.000895255	2	.000846024	7	.000801925
8	.00101215	3	.000949668	18	.000894454	3	.000845308	8	.000801282
9	.00101112	4	.000948767	19	.000893655	4	.000844595	9	.000800640
990	.00101010	5	.000947867	1120	.000892857	5	.000843882	1250	.000800000
1	.00100908	6	.000946970	1	.000892061	6	.000843170	1	.000799360
2	.00100806	7	.000946074	2	.000891266	7	.000842460	2	.000798722
3	.00100705	8	.000945180	3	.000890472	8	.000841751	3	.000798085
4	.00100604	9	.000944287	4	.000889680	9	.000841043	4	.000797448
5	.00100502	1060	.000943396	5	.000888889	1190	.000840336	5	.000796813
6	.00100402	1	.000942507	6	.000888099	1	.000839631	6	.000796178
7	.00100301	2	.000941620	7	.000887311	2	.000838926	7	.000795545
8	.00100200	3	.000940734	8	.000886525	3	.000838222	8	.000794913
9	.00100100	4	.000939850	9	.000885740	4	.000837521	9	.000794281
1000	.00100000	5	.000938967	1130	.000884956	5	.000836820	1260	.000793651
1	.000999901	6	.000938086	1	.000884173	6	.000836120	1	.000793021
2	.000999804	7	.000937207	2	.000883392	7	.000835422	2	.000792393
3	.000999709	8	.000936330	3	.000882612	8	.000834724	3	.000791766
4	.000999616	9	.000935454	4	.000881834	9	.000834028	4	.000791139
5	.000999525	1070	.000934579	5	.000881057	1200	.000833333	5	.000790514
6	.000999436	1	.000933707	6	.000880282	1	.000832639	6	.000789889
7	.000999349	2	.000932836	7	.000879508	2	.000831947	7	.000789266
8	.000999263	3	.000931966	8	.000878735	3	.000831255	8	.000788643
9	.000999180	4	.000931099	9	.000877963	4	.000830565	9	.000788022
1010	.000999099	5	.000930233	1140	.000877193	5	.000829875	1270	.000787402
11	.0009989120	6	.000929368	1	.000876424	6	.000829187	1	.000786782
12	.0009988142	7	.000928505	2	.000875657	7	.000828500	2	.000786163
13	.0009987167	8	.000927644	3	.000874891	8	.000827815	3	.000785546
14	.0009986193	9	.000926784	4	.000874126	9	.000827130	4	.000784929
15	.0009985222	1030	.000925926	5	.000873362	1210	.000826446	5	.000784314
16	.0009984252	1	.000925069	6	.000872600	11	.000825764	6	.000783699
17	.0009983284	2	.000924214	7	.000871840	12	.000825082	7	.000783085
18	.0009982318	3	.000923361	8	.000871080	13	.000824402	8	.000782473
19	.0009981354	4	.000922509	9	.000870322	14	.000823723	9	.000781861
1020	.0009980392	5	.000921659	1150	.000869565	15	.000823045	1280	.000781250
1	.0009979432	6	.000920810	1	.000868810	16	.000822368	1	.000780640
2	.0009978474	7	.000919963	2	.000868056	17	.000821693	2	.000780031
3	.0009977517	8	.000919118	3	.000867303	18	.000821018	3	.000779423
4	.0009976562	9	.000918274	4	.000866551	19	.000820344	4	.000778816
5	.0009975610	1090	.000917431	5	.000865801	1220	.000819672	5	.000778210
6	.0009974659	1	.000916590	6	.000865052	1	.000819001	6	.000777605
7	.0009973710	2	.000915757	7	.000864304	2	.000818331	7	.000777001
8	.0009972763	3	.000914913	8	.000863558	3	.000817661	8	.000776397
9	.0009971817	4	.000914079	9	.000862813	4	.000816993	9	.000775795
1030	.0009970874	5	.000913242	1160	.000862069	5	.000816326	1290	.000775194



No.	Reciprocal.	No.	Reciprocal.	No.	Reciprocal.	No.	Reciprocal.	No.	Reciprocal.
1291	.000774593	1356	.000737463	1421	.000703730	1486	.000672948	1551	.000644745
2	.000773994	7	.000736920	2	.000703235	7	.000672495	2	.000644330
3	.000773395	8	.000736377	3	.000702741	8	.000672043	3	.000643915
4	.000772797	9	.000735835	4	.000702247	9	.000671592	4	.000643501
5	.000772201	1360	.000735294	5	.000701754	1490	.000671141	5	.000643087
6	.000771605	1	.000734754	6	.000701262	1	.000670691	6	.000642673
7	.000771010	2	.000734214	7	.000700771	2	.000670241	7	.000642261
8	.000770416	3	.000733676	8	.000700280	3	.000669792	8	.000641848
9	.000769823	4	.000733138	9	.000699790	4	.000669344	9	.000641437
1300	.000769231	5	.000732601	1430	.000699301	5	.000668896	1560	.000641026
1	.000768639	6	.000732064	1	.000698812	6	.000668449	1	.000640615
2	.000768049	7	.000731529	2	.000698324	7	.000668003	2	.000640205
3	.000767459	8	.000730994	3	.000697837	8	.000667557	3	.000639795
4	.000766871	9	.000730460	4	.000697350	9	.000667111	4	.000639386
5	.000766283	1370	.000729927	5	.000696864	1500	.000666667	5	.000638978
6	.000765697	1	.000729395	6	.000696379	1	.000666223	6	.000638570
7	.000765111	2	.000728863	7	.000695894	2	.000665779	7	.000638162
8	.000764526	3	.000728332	8	.000695410	3	.000665336	8	.000637755
9	.000763942	4	.000727802	9	.000694927	4	.000664894	9	.000637349
1310	.000763359	5	.000727273	1440	.000694444	5	.000664452	1570	.000636943
11	.000762776	6	.000726744	1	.000693962	6	.000664011	1	.000636537
12	.000762195	7	.000726216	2	.000693481	7	.000663570	2	.000636132
13	.000761615	8	.000725689	3	.000693001	8	.000663130	3	.000635728
14	.000761035	9	.000725163	4	.000692521	9	.000662691	4	.000635324
15	.000760456	1380	.000724638	5	.000692041	1510	.000662252	5	.000634921
16	.000759878	1	.000724113	6	.000691563	11	.000661813	6	.000634518
17	.000759301	2	.000723589	7	.000691085	12	.000661376	7	.000634115
18	.000758725	3	.000723066	8	.000690608	13	.000660939	8	.000633714
19	.000758150	4	.000722543	9	.000690131	14	.000660502	9	.000633312
1320	.000757576	5	.000722022	1450	.000689655	15	.000660066	1580	.000632911
1	.000757002	6	.000721501	1	.000689180	16	.000659631	1	.000632511
2	.000756430	7	.000720980	2	.000688705	17	.000659196	2	.000632111
3	.000755858	8	.000720461	3	.000688231	18	.000658761	3	.000631712
4	.000755287	9	.000719942	4	.000687758	19	.000658328	4	.000631313
5	.000754717	1390	.000719424	5	.000687285	1520	.000657895	5	.000630915
6	.000754148	1	.000718907	6	.000686813	1	.000657462	6	.000630517
7	.000753579	2	.000718391	7	.000686341	2	.000657030	7	.000630120
8	.000753012	3	.000717875	8	.000685871	3	.000656598	8	.000629723
9	.000752445	4	.000717360	9	.000685401	4	.000656168	9	.000629327
1330	.000751880	5	.000716846	1460	.000684932	5	.000655738	1590	.000628931
1	.000751315	6	.000716332	1	.000684463	6	.000655308	1	.000628536
2	.000750750	7	.000715820	2	.000683994	7	.000654879	2	.000628141
3	.000750187	8	.000715308	3	.000683527	8	.000654450	3	.000627746
4	.000749625	9	.000714796	4	.000683060	9	.000654022	4	.000627353
5	.000749064	1400	.000714286	5	.000682594	1530	.000653595	5	.000626959
6	.000748503	1	.000713776	6	.000682128	1	.000653168	6	.000626566
7	.000747943	2	.000713267	7	.000681663	2	.000652742	7	.000626174
8	.000747384	3	.000712758	8	.000681199	3	.000652316	8	.000625782
9	.000746826	4	.000712251	9	.000680735	4	.000651890	9	.000625391
1340	.000746269	5	.000711744	1470	.000680272	5	.000651466	1600	.000625000
1	.000745712	6	.000711238	1	.000679810	6	.000651042	2	.000624219
2	.000745156	7	.000710732	2	.000679348	7	.000650618	4	.000623441
3	.000744602	8	.000710227	3	.000678887	8	.000650195	6	.000622665
4	.000744048	9	.000709723	4	.000678426	9	.000649773	8	.000621890
5	.000743494	1410	.000709220	5	.000677966	1540	.000649351	1610	.000621118
6	.000742942	11	.000708717	6	.000677507	1	.000648929	12	.000620347
7	.000742390	12	.000708215	7	.000677048	2	.000648508	14	.000619578
8	.000741840	13	.000707714	8	.000676590	3	.000648088	16	.000618812
9	.000741290	14	.000707214	9	.000676132	4	.000647668	18	.000618047
1350	.000740741	15	.000706714	1480	.000675676	5	.000647249	1620	.000617284
1	.000740192	16	.000706215	1	.000675219	6	.000646830	2	.000616523
2	.000739645	17	.000705716	2	.000674764	7	.000646412	4	.000615763
3	.000739098	18	.000705219	3	.000674309	8	.000645995	6	.000615006
4	.000738552	19	.000704722	4	.000673854	9	.000645578	8	.000614250
5	.000738007	1420	.000704225	5	.000673401	1550	.000645161	1630	.000613497

No.	Reciprocal.	No.	Reciprocal.	No.	Reciprocal.	No.	Reciprocal.	No.	Reciprocal.
1632	.000612745	1706	.000586166	1780	.000561798	1854	.000539374	1928	.000518672
4	.000611995	8	.000585480	2	.000561167	6	.000538793	1930	.000518135
6	.000611247	1710	.000584795	4	.000560538	8	.000538213	2	.000517599
8	.000610500	12	.000584112	6	.000559910	1860	.000537634	4	.000517063
1640	.000609756	14	.000583430	8	.000559284	2	.000537057	6	.000516528
2	.000609013	16	.000582750	1790	.000558659	4	.000536480	8	.000515996
4	.000608272	18	.000582072	2	.000558035	6	.000535905	1940	.000515464
6	.000607533	1720	.000581395	4	.000557413	8	.000535332	2	.000514933
8	.000606796	2	.000580720	6	.000556793	1870	.000534759	4	.000514403
1650	.000506061	4	.000580046	8	.000556174	2	.000534188	6	.000513874
2	.000605327	6	.000579374	1800	.000555556	4	.000533618	8	.000513347
4	.000604595	8	.000578704	2	.000554939	6	.000533049	1950	.000512820
6	.000603865	1730	.000578035	4	.000554324	8	.000532481	2	.000512295
8	.000603136	2	.000577367	6	.000553710	1880	.000531915	4	.000511770
1660	.000602410	4	.000576701	8	.000553097	2	.000531350	6	.000511247
2	.000601685	6	.000576037	1810	.000552486	4	.000530785	8	.000510725
4	.000500962	8	.000575374	12	.000551876	6	.000530222	1960	.000510204
6	.000600240	1740	.000574713	14	.000551268	8	.000529661	2	.000509684
8	.000599520	2	.000574053	16	.000550661	1890	.000529100	4	.000509165
1670	.000598802	4	.000573394	18	.000550055	2	.000528541	6	.000508647
2	.000598086	6	.000572737	1820	.000549451	4	.000527983	8	.000508130
4	.000597371	8	.000572082	2	.000548848	6	.000527426	1970	.000507614
6	.000596658	1750	.000571429	4	.000548246	8	.000526870	2	.000507099
8	.000595947	2	.000570776	6	.000547645	1900	.000526316	4	.000506585
1680	.000595238	4	.000570125	8	.000547046	2	.000525762	6	.000506073
2	.000594530	6	.000569476	1830	.000546448	4	.000525210	8	.000505561
4	.000593824	8	.000568828	2	.000545851	6	.000524659	1980	.000505051
6	.000593120	1760	.000568182	4	.000545256	8	.000524109	2	.000504541
8	.000592417	2	.000567537	6	.000544662	1910	.000523560	4	.000504032
1690	.000591716	4	.000566893	8	.000544069	12	.000523012	6	.000503524
2	.000591017	6	.000566251	1840	.000543478	14	.000522466	8	.000503018
4	.000590319	8	.000565611	2	.000542888	16	.000521920	1990	.000502513
6	.000589622	1770	.000564972	4	.000542299	18	.000521376	2	.000502008
8	.000588928	2	.000564334	6	.000541711	1920	.000520833	4	.000501504
1700	.000588235	4	.000563698	8	.000541125	2	.000520291	6	.000501002
2	.000587544	6	.000563063	1850	.000540540	4	.000519750	8	.000500501
4	.000586854	8	.000562430	2	.000539957	6	.000519211	2000	.000500000

**Use of reciprocals.** — Reciprocals may be conveniently used to facilitate computations in long division. Instead of dividing as usual, multiply the dividend by the reciprocal of the divisor. The method is especially useful when many different dividends are required to be divided by the same divisor. In this case find the reciprocal of the divisor, and make a small table of its multiples up to 9 times, and use this as a multiplication-table instead of actually performing the multiplication in each case.

**EXAMPLE.** — 9871 and several other numbers are to be divided by 1638. The reciprocal of 1638 is .000610500.

Multiples of the reciprocal:

1. .0006105
2. .0012210
3. .0018315
4. .0024420
5. .0030525
6. .0036630
7. .0042735
8. .0048840
9. .0054945
10. .0061050

The table of multiples is made by continuous addition of 6105. The tenth line is written to check the accuracy of the addition, but it is not afterwards used.

*Operation:*

Dividend	9871	
Take from table	1.....	.0006105
	7.....	0.042735
	8.....	00.48840
	9.....	005.4945

Quotient..... 6.0262455  
 Correct quotient by direct division..... 6.0262515

The result will generally be correct to as many figures as there are significant figures in the reciprocal, less one, and the error of the next figure will in general not exceed one. In the above example the reciprocal has six significant figures, 610500, and the result is correct to five places of figures.

SQUARES, CUBES, SQUARE ROOTS AND CUBE ROOTS OF  
 NUMBERS FROM 0.1 TO 1600.

No.	Square.	Cube.	Sq. Root.	Cube Root.	No.	Square.	Cube.	Sq. Root.	Cube Root.
0.1	.01	.001	.3162	.4642	3.1	9.61	29.791	1.761	1.458
.15	.0225	.0034	.3873	.5313	.2	10.24	32.768	1.789	1.474
.2	.04	.008	.4472	.5848	.3	10.89	35.937	1.817	1.489
.25	.0625	.0156	.500	.6300	.4	11.56	39.304	1.844	1.504
.3	.09	.027	.5477	.6694	.5	12.25	42.875	1.871	1.518
.35	.1225	.0429	.5916	.7047	.6	12.96	46.656	1.897	1.533
.4	.16	.064	.6325	.7368	.7	13.69	50.653	1.924	1.547
.45	.2025	.0911	.6708	.7663	.8	14.44	54.872	1.949	1.560
.5	.25	.125	.7071	.7937	.9	15.21	59.319	1.975	1.574
.55	.3025	.1664	.7416	.8193	4.	16.	64.	2.	1.5874
.6	.36	.216	.7746	.8434	.1	16.81	68.921	2.025	1.601
.65	.4225	.2746	.8062	.8662	.2	17.64	74.088	2.049	1.613
.7	.49	.343	.8367	.8879	.3	18.49	79.507	2.074	1.626
.75	.5625	.4219	.8660	.9086	.4	19.36	85.184	2.098	1.639
.8	.64	.512	.8944	.9283	.5	20.25	91.125	2.121	1.651
.85	.7225	.6141	.9219	.9473	.6	21.16	97.336	2.145	1.663
.9	.81	.729	.9487	.9655	.7	22.09	103.823	2.168	1.675
.95	.9025	.8574	.9747	.9830	.8	23.04	110.592	2.191	1.687
1.	1.	1.	1.	1.	.9	24.01	117.649	2.214	1.698
1.05	1.1025	1.158	1.025	1.016	5.	25.	125.	2.2361	1.7100
1.1	1.21	1.331	1.049	1.032	.1	26.01	132.651	2.258	1.721
1.15	1.3225	1.521	1.072	1.048	.2	27.04	140.608	2.280	1.732
1.2	1.44	1.728	1.095	1.063	.3	28.09	148.877	2.302	1.744
1.25	1.5625	1.953	1.118	1.077	.4	29.16	157.464	2.324	1.754
1.3	1.69	2.197	1.140	1.091	.5	30.25	166.375	2.345	1.765
1.35	1.8225	2.460	1.162	1.105	.6	31.36	175.616	2.366	1.776
1.4	1.96	2.744	1.183	1.119	.7	32.49	185.193	2.387	1.786
1.45	2.1025	3.049	1.204	1.132	.8	33.64	195.112	2.408	1.797
1.5	2.25	3.375	1.2247	1.1447	.9	34.81	205.379	2.429	1.807
1.55	2.4025	3.724	1.245	1.157	6.	36.	216.	2.4495	1.8171
1.6	2.56	4.096	1.265	1.170	.1	37.21	226.981	2.470	1.827
1.65	2.7225	4.492	1.285	1.182	.2	38.44	238.328	2.490	1.837
1.7	2.89	4.913	1.304	1.193	.3	39.69	250.047	2.510	1.847
1.75	3.0625	5.359	1.323	1.205	.4	40.96	262.144	2.530	1.857
1.8	3.24	5.832	1.342	1.216	.5	42.25	274.625	2.550	1.866
1.85	3.4225	6.332	1.360	1.228	.6	43.56	287.496	2.569	1.876
1.9	3.61	6.859	1.378	1.239	.7	44.89	300.763	2.588	1.885
1.95	3.8025	7.415	1.396	1.249	.8	46.24	314.432	2.608	1.895
2.	4.	8.	1.4142	1.2599	.9	47.61	328.509	2.627	1.904
.1	4.41	9.261	1.449	1.281	7.	49.	343.	2.6458	1.9129
.2	4.84	10.648	1.483	1.301	.1	50.41	357.911	2.665	1.922
.3	5.29	12.167	1.517	1.320	.2	51.84	373.248	2.683	1.931
.4	5.76	13.824	1.549	1.339	.3	53.29	389.017	2.702	1.940
.5	6.25	15.625	1.581	1.357	.4	54.76	405.224	2.720	1.949
.6	6.76	17.576	1.612	1.375	.5	56.25	421.875	2.739	1.957
.7	7.29	19.683	1.643	1.392	.6	57.76	438.976	2.757	1.966
.8	7.84	21.952	1.673	1.409	.7	59.29	456.533	2.775	1.975
.9	8.41	24.389	1.703	1.426	.8	60.84	474.552	2.793	1.983
3.	9.	27.	1.7321	1.4422	.9	62.41	493.039	2.811	1.992



No.	Square.	Cube.	Sq. Root.	Cube Root.	No.	Square	Cube.	Sq. Root.	Cube Root.
8.	64.	512.	2.8284	2.	45	2025	91125	6.7082	3.5569
.1	65.61	531.441	2.846	2.008	46	2116	97336	6.7823	3.5830
.2	67.24	551.368	2.864	2.017	47	2209	103823	6.8557	3.6088
.3	68.89	571.787	2.881	2.025	48	2304	110592	6.9282	3.6342
.4	70.56	592.704	2.898	2.033	49	2401	117649	7.	3.6593
.5	72.25	614.125	2.915	2.041	50	2500	125000	7.0711	3.6840
.6	73.96	636.056	2.933	2.049	51	2601	132651	7.1414	3.7084
.7	75.69	658.503	2.950	2.057	52	2704	140608	7.2111	3.7325
.8	77.44	681.472	2.966	2.065	53	2809	148877	7.2801	3.7563
.9	79.21	704.969	2.983	2.072	54	2916	157464	7.3485	3.7798
9.	81.	729.	3.	2.0801	55	3025	166375	7.4162	3.8030
.1	82.81	753.571	3.017	2.088	56	3136	175616	7.4833	3.8259
.2	84.64	778.688	3.033	2.095	57	3249	185193	7.5498	3.8485
.3	86.49	804.357	3.050	2.103	58	3364	195112	7.6158	3.8709
.4	88.36	830.584	3.066	2.110	59	3481	205379	7.6811	3.8930
.5	90.25	857.375	3.082	2.118	60	3600	216000	7.7460	3.9149
.6	92.16	884.736	3.098	2.125	61	3721	226981	7.8102	3.9365
.7	94.09	912.673	3.114	2.133	62	3844	238328	7.8740	3.9579
.8	96.04	941.192	3.130	2.140	63	3969	250047	7.9373	3.9791
.9	98.01	970.299	3.146	2.147	64	4096	262144	8.	4.
10	100	1000	3.1623	2.1544	65	4225	274625	8.0623	4.0207
11	121	1331	3.3166	2.2240	66	4356	287496	8.1240	4.0412
12	144	1728	3.4641	2.2894	67	4489	300763	8.1854	4.0615
13	169	2197	3.6056	2.3513	68	4624	314432	8.2462	4.0817
14	196	2744	3.7417	2.4101	69	4761	328509	8.3066	4.1016
15	225	3375	3.8730	2.4662	70	4900	343000	8.3666	4.1213
16	256	4096	4.	2.5198	71	5041	357911	8.4261	4.1408
17	289	4913	4.1231	2.5713	72	5184	373248	8.4853	4.1602
18	324	5832	4.2426	2.6207	73	5329	389017	8.5440	4.1793
19	361	6859	4.3589	2.6684	74	5476	405224	8.6023	4.1983
20	400	8000	4.4721	2.7144	75	5625	421875	8.6603	4.2172
21	441	9261	4.5826	2.7589	76	5776	438976	8.7178	4.2358
22	484	10648	4.6904	2.8020	77	5929	456533	8.7750	4.2543
23	529	12167	4.7958	2.8439	78	6084	474552	8.8318	4.2727
24	576	13824	4.8990	2.8845	79	6241	493039	8.8882	4.2908
25	625	15625	5.	2.9240	80	6400	512000	8.9443	4.3089
26	676	17576	5.0990	2.9625	81	6561	531441	9.	4.3267
27	729	19683	5.1962	3.	82	6724	551368	9.0554	4.3445
28	784	21952	5.2915	3.0366	83	6889	571787	9.1104	4.3621
29	841	24389	5.3852	3.0723	84	7056	592704	9.1652	4.3795
30	900	27000	5.4772	3.1072	85	7225	614125	9.2195	4.3968
31	961	29791	5.5678	3.1414	86	7396	636056	9.2736	4.4140
32	1024	32768	5.6569	3.1748	87	7569	658503	9.3276	4.4310
33	1089	35937	5.7446	3.2075	88	7744	681472	9.3808	4.4486
34	1156	39304	5.8310	3.2396	89	7921	704969	9.4340	4.4647
35	1225	42875	5.9161	3.2711	90	8100	729000	9.4868	4.4814
36	1296	46656	6.	3.3019	91	8281	753571	9.5394	4.4979
37	1369	50653	6.0828	3.3322	92	8464	778688	9.5917	4.5144
38	1444	54872	6.1644	3.3620	93	8649	804357	9.6437	4.5307
39	1521	59319	6.2450	3.3912	94	8836	830584	9.6954	4.5468
40	1600	64000	6.3246	3.4200	95	9025	857375	9.7468	4.5629
41	1681	68921	6.4031	3.4482	96	9216	884736	9.7980	4.5789
42	1764	74088	6.4807	3.4760	97	9409	912673	9.8489	4.5947
43	1849	79507	6.5574	3.5034	98	9604	941192	9.8995	4.6104
44	1936	85184	6.6332	3.5303	99	9801	970299	9.9499	4.6261



No.	Sq.	Cube.	Sq. Root.	Cube Root.	No.	Square.	Cube.	Sq. Root.	Cube Root.
100	10000	1000000	10.	4.6416	155	24025	3723875	12.4499	5.3717
101	10201	1030301	10.0499	4.6570	156	24336	3796416	12.4900	5.3832
102	10404	1061208	10.0995	4.6723	157	24649	3869893	12.5300	5.3947
103	10609	1092727	10.1489	4.6875	158	24964	3944312	12.5698	5.4061
104	10816	1124864	10.1980	4.7027	159	25281	4019679	12.6095	5.4175
105	11025	1157625	10.2470	4.7177	160	25600	4096000	12.6491	5.4288
106	11236	1191016	10.2956	4.7326	161	25921	4173281	12.6886	5.4401
107	11449	1225043	10.3441	4.7475	162	26244	4251528	12.7279	5.4514
108	11664	1259712	10.3923	4.7622	163	26569	4330747	12.7671	5.4626
109	11881	1295029	10.4403	4.7769	164	26896	4410944	12.8062	5.4737
110	12100	1331000	10.4881	4.7914	165	27225	4492125	12.8452	5.4848
111	12321	1367631	10.5357	4.8059	166	27556	4574296	12.8841	5.4959
112	12544	1404928	10.5830	4.8203	167	27889	4657463	12.9228	5.5069
113	12769	1442897	10.6301	4.8346	168	28224	4741632	12.9615	5.5178
114	12996	1481544	10.6771	4.8488	169	28561	4826809	13.0000	5.5288
115	13225	1520875	10.7238	4.8629	170	28900	4913000	13.0384	5.5397
116	13456	1560896	10.7703	4.8770	171	29241	5000211	13.0767	5.5505
117	13689	1601613	10.8167	4.8910	172	29584	5088448	13.1149	5.5613
118	13924	1643032	10.8628	4.9049	173	29929	5177717	13.1529	5.5721
119	14161	1685159	10.9087	4.9187	174	30276	5268024	13.1909	5.5828
120	14400	1728000	10.9545	4.9324	175	30625	5359375	13.2288	5.5934
121	14641	1771561	11.0000	4.9461	176	30976	5451776	13.2665	5.6041
122	14884	1815848	11.0454	4.9597	177	31329	5545233	13.3041	5.6147
123	15129	1860867	11.0905	4.9732	178	31684	5639752	13.3417	5.6252
124	15376	1906624	11.1355	4.9866	179	32041	5735339	13.3791	5.6357
125	15625	1953125	11.1803	5.0000	180	32400	5832000	13.4164	5.6462
126	15876	2000376	11.2250	5.0133	181	32761	5929741	13.4536	5.6567
127	16129	2048383	11.2694	5.0265	182	33124	6028568	13.4907	5.6671
128	16384	2097152	11.3137	5.0397	183	33489	6128487	13.5277	5.6774
129	16641	2146689	11.3578	5.0528	184	33856	6229504	13.5647	5.6877
130	16900	2197000	11.4018	5.0658	185	34225	6331625	13.6015	5.6980
131	17161	2248091	11.4455	5.0788	186	34596	6434856	13.6382	5.7083
132	17424	2299968	11.4891	5.0916	187	34969	6539203	13.6748	5.7185
133	17689	2352637	11.5326	5.1045	188	35344	6644672	13.7113	5.7287
134	17956	2406104	11.5758	5.1172	189	35721	6751269	13.7477	5.7388
135	18225	2460375	11.6190	5.1299	190	36100	6859000	13.7840	5.7489
136	18496	2515456	11.6619	5.1426	191	36481	6967871	13.8203	5.7590
137	18769	2571353	11.7047	5.1551	192	36864	7077888	13.8564	5.7690
138	19044	2628072	11.7473	5.1676	193	37249	7189057	13.8924	5.7790
139	19321	2685619	11.7898	5.1801	194	37636	7301384	13.9284	5.7890
140	19600	2744000	11.8322	5.1925	195	38025	7414875	13.9642	5.7989
141	19881	2803221	11.8743	5.2048	196	38416	7529536	14.0000	5.8088
142	20164	2863288	11.9164	5.2171	197	38809	7645373	14.0357	5.8186
143	20449	2924207	11.9583	5.2293	198	39204	7762392	14.0712	5.8285
144	20736	2985984	12.0000	5.2415	199	39601	7880599	14.1067	5.8383
145	21025	3048625	12.0416	5.2536	200	40000	8000000	14.1421	5.8480
146	21316	3112136	12.0830	5.2656	201	40401	8120601	14.1774	5.8578
147	21609	3176523	12.1244	5.2776	202	40804	8242408	14.2127	5.8675
148	21904	3241792	12.1655	5.2896	203	41209	8365427	14.2478	5.8771
149	22201	3307949	12.2066	5.3015	204	41616	8489664	14.2829	5.8868
150	22500	3375000	12.2474	5.3133	205	42025	8615125	14.3178	5.8964
151	22801	3442951	12.2882	5.3251	206	42436	8741816	14.3527	5.9059
152	23104	3511808	12.3288	5.3368	207	42849	8869743	14.3875	5.9155
153	23409	3581577	12.3693	5.3485	208	43264	8998912	14.4222	5.9250
154	23716	3652264	12.4097	5.3601	209	43681	9129329	14.4568	5.9345

No.	Sq.	Cube.	Sq. Root.	Cube Root.	No.	Square.	Cube.	Sq. Root.	Cube Root.
210	44100	9261000	14.4914	5.9439	265	70225	18609625	16.2788	6.4232
211	44521	9393931	14.5258	5.9533	266	70756	18821096	16.3095	6.4312
212	44944	9528128	14.5602	5.9627	267	71289	19034163	16.3401	6.4393
213	45369	9663597	14.5945	5.9721	268	71824	19248832	16.3707	6.4473
214	45796	9800344	14.6287	5.9814	269	72361	19465109	16.4012	6.4553
215	46225	9938375	14.6629	5.9907	270	72900	19683000	16.4317	6.4633
216	46656	10077696	14.6969	6.0000	271	73441	19902511	16.4621	6.4713
217	47089	10218313	14.7309	6.0092	272	73984	20123648	16.4924	6.4792
218	47524	10360232	14.7648	6.0185	273	74529	20346417	16.5227	6.4872
219	47961	10503459	14.7986	6.0277	274	75076	20570824	16.5529	6.4951
220	48400	10648000	14.8324	6.0368	275	75625	20796875	16.5831	6.5030
221	48841	10793861	14.8661	6.0459	276	76176	21024576	16.6132	6.5108
222	49284	10941048	14.8997	6.0550	277	76729	21253933	16.6433	6.5187
223	49729	11089567	14.9332	6.0641	278	77284	21484952	16.6733	6.5265
224	50176	11239424	14.9666	6.0732	279	77841	21717639	16.7033	6.5343
225	50625	11390625	15.0000	6.0822	280	78400	21952000	16.7332	6.5421
226	51076	11543176	15.0333	6.0912	281	78961	22188041	16.7631	6.5499
227	51529	11697083	15.0665	6.1002	282	79524	22425768	16.7929	6.5577
228	51984	11852352	15.0997	6.1091	283	80089	22665187	16.8226	6.5654
229	52441	12008989	15.1327	6.1180	284	80656	22906304	16.8523	6.5731
230	52900	12167000	15.1658	6.1269	285	81225	23149125	16.8819	6.5808
231	53361	12326391	15.1987	6.1358	286	81796	23393656	16.9115	6.5885
232	53824	12487168	15.2315	6.1446	287	82369	23639903	16.9411	6.5962
233	54289	12649337	15.2643	6.1534	288	82944	23887872	16.9706	6.6039
234	54756	12812904	15.2971	6.1622	289	83521	24137569	17.0000	6.6115
235	55225	12977875	15.3297	6.1710	290	84100	24389000	17.0294	6.6191
236	55696	13144256	15.3623	6.1797	291	84681	24642171	17.0587	6.6267
237	56169	13312053	15.3948	6.1885	292	85264	24897088	17.0880	6.6343
238	56644	13481272	15.4272	6.1972	293	85849	25153757	17.1172	6.6419
239	57121	13651919	15.4596	6.2058	294	86436	25412184	17.1464	6.6494
240	57600	13824000	15.4919	6.2145	295	87025	25672375	17.1756	6.6569
241	58081	13997521	15.5242	6.2231	296	87616	25934336	17.2047	6.6644
242	58564	14172488	15.5563	6.2317	297	88209	26198073	17.2337	6.6719
243	59049	14348907	15.5885	6.2403	298	88804	26463592	17.2627	6.6794
244	59536	14526784	15.6205	6.2488	299	89401	26730899	17.2916	6.6869
245	60025	14706125	15.6525	6.2573	300	90000	27000000	17.3205	6.6943
246	60516	14886936	15.6844	6.2658	301	90601	27270901	17.3494	6.7018
247	61009	15069223	15.7162	6.2743	302	91204	27543608	17.3781	6.7092
248	61504	15252992	15.7480	6.2828	303	91809	27818127	17.4069	6.7166
249	62001	15438249	15.7797	6.2912	304	92416	28094464	17.4356	6.7240
250	62500	15625000	15.8114	6.2996	305	93025	28372625	17.4642	6.7313
251	63001	15813251	15.8430	6.3080	306	93636	28652616	17.4929	6.7387
252	63504	16003008	15.8745	6.3164	307	94249	28934443	17.5214	6.7460
253	64009	16194277	15.9060	6.3247	308	94864	29218112	17.5499	6.7533
254	64516	16387064	15.9374	6.3330	309	95481	29503629	17.5784	6.7606
255	65025	16581375	15.9687	6.3413	310	96100	29791000	17.6068	6.7679
256	65536	16777216	16.0000	6.3496	311	96721	30080231	17.6352	6.7752
257	66049	16974593	16.0312	6.3579	312	97344	30371328	17.6635	6.7824
258	66564	17173512	16.0624	6.3661	313	97969	30664297	17.6918	6.7897
259	67081	17373979	16.0935	6.3743	314	98596	30959144	17.7200	6.7969
260	67600	17576000	16.1245	6.3825	315	99225	31255875	17.7482	6.8041
261	68121	17779581	16.1555	6.3907	316	99856	31554496	17.7764	6.8113
262	68644	17984728	16.1864	6.3988	317	100489	31855013	17.8045	6.8185
263	69169	18191447	16.2173	6.4070	318	101124	32157432	17.8326	6.8256
264	69696	18399744	16.2481	6.4151	319	101761	32461759	17.8606	6.8328

No.	Square.	Cube.	Sq. Root.	Cube Root.	No.	Square	Cube.	Sq. Root.	Cube Root.
320	102400	32768000	17.8885	6.8399	375	140625	52734375	19.3649	7.2112
321	103041	33076161	17.9165	6.8470	376	141376	53157376	19.3907	7.2177
322	103684	33386248	17.9444	6.8541	377	142129	53582633	19.4165	7.2240
323	104329	33698267	17.9722	6.8612	378	142884	54010152	19.4422	7.2304
324	104976	34012224	18.0000	6.8683	379	143641	54439939	19.4679	7.2368
325	105625	34328125	18.0278	6.8753	380	144400	54872000	19.4936	7.2432
326	106276	34645976	18.0555	6.8824	381	145161	55306341	19.5192	7.2495
327	106929	34965783	18.0831	6.8894	382	145924	55742968	19.5448	7.2558
328	107584	35287552	18.1108	6.8964	383	146689	56181887	19.5704	7.2622
329	108241	35611289	18.1384	6.9034	384	147456	56623104	19.5959	7.2685
330	108900	35937000	18.1659	6.9104	385	148225	57066625	19.6214	7.2748
331	109561	36264691	18.1934	6.9174	386	148996	57512456	19.6469	7.2811
332	110224	36594368	18.2209	6.9244	387	149769	57960603	19.6723	7.2874
333	110889	36926037	18.2483	6.9313	388	150544	58411072	19.6977	7.2936
334	111556	37259704	18.2757	6.9382	389	151321	58863869	19.7231	7.2999
335	112225	37595375	18.3030	6.9451	390	152100	59319000	19.7484	7.3061
336	112896	37933056	18.3303	6.9521	391	152881	59776471	19.7737	7.3124
337	113569	38272753	18.3576	6.9589	392	153664	60236288	19.7990	7.3186
338	114244	38614472	18.3848	6.9658	393	154449	60698457	19.8242	7.3248
339	114921	38958219	18.4120	6.9727	394	155236	61162984	19.8494	7.3310
340	115600	39304000	18.4391	6.9795	395	156025	61629875	19.8746	7.3372
341	116281	39651821	18.4662	6.9864	396	156816	62099136	19.8997	7.3434
342	116964	40001688	18.4932	6.9932	397	157609	62570773	19.9249	7.3496
343	117649	40353607	18.5203	7.0000	398	158404	63044792	19.9499	7.3558
344	118336	40707584	18.5472	7.0068	399	159201	63521199	19.9750	7.3619
345	119025	41063625	18.5742	7.0136	400	160000	64000000	20.0000	7.3681
346	119716	41421736	18.6011	7.0203	401	160801	64481201	20.0250	7.3742
347	120409	41781923	18.6279	7.0271	402	161604	64964808	20.0499	7.3803
348	121104	42144192	18.6548	7.0338	403	162409	65450827	20.0749	7.3864
349	121801	42508549	18.6815	7.0406	404	163216	65939264	20.0998	7.3925
350	122500	42875000	18.7083	7.0473	405	164025	66430125	20.1246	7.3986
351	123201	43243551	18.7350	7.0540	406	164836	66923416	20.1494	7.4047
352	123904	43614208	18.7617	7.0607	407	165649	67419143	20.1742	7.4108
353	124609	43986977	18.7883	7.0674	408	166464	67917312	20.1990	7.4169
354	125316	44361864	18.8149	7.0740	409	167281	68417929	20.2237	7.4229
355	126025	44738875	18.8414	7.0807	410	168100	68921000	20.2485	7.4290
356	126736	45118016	18.8680	7.0873	411	168921	69426531	20.2731	7.4350
357	127449	45499293	18.8944	7.0940	412	169744	69934528	20.2978	7.4410
358	128164	45882712	18.9209	7.1006	413	170569	70444997	20.3224	7.4470
359	128881	46268279	18.9473	7.1072	414	171396	70957944	20.3470	7.4530
360	129600	46656000	18.9737	7.1138	415	172225	71473375	20.3715	7.4590
361	130321	47045881	19.0000	7.1204	416	173056	71991296	20.3961	7.4650
362	131044	47437928	19.0263	7.1269	417	173889	72511713	20.4206	7.4710
363	131769	47832147	19.0526	7.1335	418	174724	73034632	20.4450	7.4770
364	132496	48228544	19.0788	7.1400	419	175561	73560059	20.4695	7.4829
365	133225	48627125	19.1050	7.1466	420	176400	74088000	20.4939	7.4889
366	133956	49027896	19.1311	7.1531	421	177241	74618461	20.5183	7.4948
367	134689	49430863	19.1572	7.1596	422	178084	75151448	20.5426	7.5007
368	135424	49836032	19.1833	7.1661	423	178929	75686967	20.5670	7.5067
369	136161	50243409	19.2094	7.1726	424	179776	76225024	20.5913	7.5126
370	136900	50653000	19.2354	7.1791	425	180625	76765625	20.6155	7.5185
371	137641	51064811	19.2614	7.1855	426	181476	77308776	20.6398	7.5244
372	138384	51478848	19.2873	7.1920	427	182329	77854483	20.6640	7.5302
373	139129	51895117	19.3132	7.1984	428	183184	78402752	20.6882	7.5361
374	139876	52313624	19.3391	7.2048	429	184041	78953589	20.7123	7.5420



No.	Square	Cube.	Sq. Root.	Cube Root.	No.	Square	Cube.	Sq. Root.	Cube Root.
430	184900	79507000	20.7364	7.5478	485	235225	114084125	22.0227	7.8568
431	185761	80062991	20.7605	7.5537	486	236196	114791256	22.0454	7.8622
432	186624	80621568	20.7846	7.5595	487	237169	115501303	22.0681	7.8676
433	187489	81182737	20.8087	7.5654	488	238144	116214272	22.0907	7.8730
434	188356	81746504	20.8327	7.5712	489	239121	116930169	22.1133	7.8784
435	189225	82312875	20.8567	7.5770	490	240100	117649000	22.1359	7.8837
436	190096	82881856	20.8806	7.5828	491	241081	118370771	22.1585	7.8891
437	190969	83453453	20.9045	7.5886	492	242064	119095488	22.1811	7.8944
438	191844	84027672	20.9284	7.5944	493	243049	119823157	22.2036	7.8998
439	192721	84604519	20.9523	7.6001	494	244036	120553784	22.2261	7.9051
440	193600	85184000	20.9762	7.6059	495	245025	121287375	22.2486	7.9105
441	194481	85766121	21.0000	7.6117	496	246016	122023936	22.2711	7.9158
442	195364	86350888	21.0238	7.6174	497	247009	122763473	22.2935	7.9211
443	196249	86938307	21.0476	7.6232	498	248004	123505992	22.3159	7.9264
444	197136	87528384	21.0713	7.6289	499	249001	124251499	22.3383	7.9317
445	198025	88121125	21.0950	7.6346	500	250000	125000000	22.3607	7.9370
446	198916	88716536	21.1187	7.6403	501	251001	125751501	22.3830	7.9423
447	199809	89314623	21.1424	7.6460	502	252004	126506008	22.4054	7.9476
448	200704	89915392	21.1660	7.6517	503	253009	127263527	22.4277	7.9528
449	201601	90518849	21.1896	7.6574	504	254016	128024064	22.4499	7.9581
450	202500	91125000	21.2132	7.6631	505	255025	128787625	22.4722	7.9634
451	203401	91733851	21.2368	7.6688	506	256036	129554216	22.4944	7.9686
452	204304	92345408	21.2603	7.6744	507	257049	130323843	22.5167	7.9739
453	205209	92959677	21.2838	7.6800	508	258064	131096512	22.5389	7.9791
454	206116	93576664	21.3073	7.6857	509	259081	131872229	22.5610	7.9843
455	207025	94196375	21.3307	7.6914	510	260100	132651000	22.5832	7.9896
456	207936	94818816	21.3542	7.6970	511	261121	133432831	22.6053	7.9948
457	208849	95443993	21.3776	7.7026	512	262144	134217728	22.6274	8.0000
458	209764	96071912	21.4009	7.7082	513	263169	135005697	22.6495	8.0052
459	210681	96702579	21.4243	7.7138	514	264196	135796744	22.6716	8.0104
460	211600	97336000	21.4476	7.7194	515	265225	136590875	22.6936	8.0156
461	212521	97972181	21.4709	7.7250	516	266256	137388096	22.7156	8.0208
462	213444	98611128	21.4942	7.7306	517	267289	138188413	22.7376	8.0260
463	214369	99252847	21.5174	7.7362	518	268324	138991832	22.7596	8.0311
464	215296	99897344	21.5407	7.7418	519	269361	139798359	22.7816	8.0363
465	216225	100544625	21.5639	7.7473	520	270400	140608000	22.8035	8.0415
466	217156	101194696	21.5870	7.7529	521	271441	141420761	22.8254	8.0466
467	218089	101847563	21.6102	7.7584	522	272484	142236648	22.8473	8.0517
468	219024	102503232	21.6333	7.7639	523	273529	143055667	22.8692	8.0569
469	219961	103161709	21.6564	7.7695	524	274576	143877824	22.8910	8.0620
470	220900	103823000	21.6795	7.7750	525	275625	144703125	22.9129	8.0671
471	221841	104487111	21.7025	7.7805	526	276676	145531576	22.9347	8.0723
472	222784	105154048	21.7256	7.7860	527	277729	146363183	22.9565	8.0774
473	223729	105823817	21.7486	7.7915	528	278784	147197952	22.9783	8.0825
474	224676	106496424	21.7715	7.7970	529	279841	148035889	23.0000	8.0876
475	225625	107171875	21.7945	7.8025	530	280900	148877000	23.0217	8.0927
476	226576	107850176	21.8174	7.8079	531	281961	149721291	23.0434	8.0978
477	227529	108531333	21.8403	7.8134	532	283024	150568768	23.0651	8.1028
478	228484	109215352	21.8632	7.8188	533	284089	151419437	23.0868	8.1079
479	229441	109902239	21.8861	7.8243	534	285156	152273304	23.1084	8.1130
480	230400	110592000	21.9089	7.8297	535	286225	153130375	23.1301	8.1180
481	231361	111284641	21.9317	7.8352	536	287296	153990656	23.1517	8.1231
482	232324	111980168	21.9545	7.8406	537	288369	154854153	23.1733	8.1281
483	233289	112678587	21.9773	7.8460	538	289444	155720872	23.1948	8.1332
484	234256	113379904	22.0000	7.8514	539	290521	156590819	23.2164	8.1382



No.	Square.	Cube.	Sq. Root.	Cube Root.	No.	Square	Cube.	Sq. Root.	Cube Root.
540	291600	157464000	23.2379	8.1433	595	354025	210644875	24.3926	8.4108
541	292681	158340421	23.2594	8.1483	596	355216	211708736	24.4131	8.4155
542	293764	159220088	23.2809	8.1533	597	356409	212776173	24.4336	8.4202
543	294849	160103007	23.3024	8.1583	598	357604	213847192	24.4540	8.4249
544	295936	160989184	23.3238	8.1633	599	358801	214921799	24.4745	8.4296
545	297025	161878625	23.3452	8.1683	600	360000	216000000	24.4949	8.4343
546	298116	162771336	23.3666	8.1733	601	361201	217081801	24.5153	8.4390
547	299209	163667323	23.3880	8.1783	602	362404	218167208	24.5357	8.4437
548	300304	164566592	23.4094	8.1833	603	363609	219256227	24.5561	8.4484
549	301401	165469149	23.4307	8.1882	604	364816	220348864	24.5764	8.4530
550	302500	166375000	23.4521	8.1932	605	366025	221445125	24.5967	8.4577
551	303601	167284151	23.4734	8.1982	606	367236	222545016	24.6171	8.4623
552	304704	168196608	23.4947	8.2031	607	368449	223648543	24.6374	8.4670
553	305809	169112377	23.5160	8.2081	608	369664	224755712	24.6577	8.4716
554	306916	170031464	23.5372	8.2130	609	370881	225866529	24.6779	8.4763
555	308025	170953875	23.5584	8.2180	610	372100	226981000	24.6982	8.4809
556	309136	171879616	23.5797	8.2229	611	373321	228099131	24.7184	8.4856
557	310249	172808693	23.6008	8.2278	612	374544	229220928	24.7386	8.4902
558	311364	173741112	23.6220	8.2327	613	375769	230346397	24.7588	8.4948
559	312481	174676879	23.6432	8.2377	614	376996	231475544	24.7790	8.4994
560	313600	175616000	23.6643	8.2426	615	378225	232608375	24.7992	8.5040
561	314721	176558481	23.6854	8.2475	616	379456	233744896	24.8193	8.5086
562	315844	177503428	23.7065	8.2524	617	380689	234885113	24.8395	8.5132
563	316969	178453547	23.7276	8.2573	618	381924	236029032	24.8596	8.5178
564	318096	179406144	23.7487	8.2621	619	383161	237176659	24.8797	8.5224
565	319225	180362125	23.7697	8.2670	620	384400	238328000	24.8998	8.5270
566	320356	181321496	23.7908	8.2719	621	385641	239483061	24.9199	8.5316
567	321489	182284263	23.8118	8.2768	622	386884	240641848	24.9399	8.5362
568	322624	183250432	23.8328	8.2816	623	388129	241804367	24.9600	8.5408
569	323761	184220009	23.8537	8.2865	624	389376	242970624	24.9800	8.5453
570	324900	185193000	23.8747	8.2913	625	390625	244140625	25.0000	8.5499
571	326041	186169411	23.8956	8.2962	626	391876	245314376	25.0200	8.5544
572	327184	187149248	23.9165	8.3010	627	393129	246491883	25.0400	8.5590
573	328329	188132517	23.9374	8.3059	628	394384	247673152	25.0599	8.5635
574	329476	189119224	23.9583	8.3107	629	395641	248858189	25.0799	8.5681
575	330625	190109375	23.9792	8.3155	630	396900	250047000	25.0998	8.5726
576	331776	191102976	24.0000	8.3203	631	398161	251239591	25.1197	8.5772
577	332929	192100033	24.0208	8.3251	632	399424	252435968	25.1396	8.5817
578	334084	193100552	24.0416	8.3300	633	400689	253636137	25.1595	8.5862
579	335241	194104539	24.0624	8.3348	634	401956	254840104	25.1794	8.5907
580	336400	195112000	24.0832	8.3396	635	403225	256047875	25.1992	8.5952
581	337561	196122941	24.1039	8.3443	636	404496	257259456	25.2190	8.5997
582	338724	197137368	24.1247	8.3491	637	405769	258474853	25.2389	8.6043
583	339889	198155287	24.1454	8.3539	638	407044	259694072	25.2587	8.6088
584	341056	199176704	24.1661	8.3587	639	408321	260917119	25.2784	8.6132
585	342225	200201625	24.1868	8.3634	640	409600	262144000	25.2982	8.6177
586	343396	201230956	24.2074	8.3682	641	410881	263374721	25.3180	8.6222
587	344569	202262003	24.2281	8.3730	642	412164	264609288	25.3377	8.6267
588	345744	203297472	24.2487	8.3777	643	413449	265847707	25.3574	8.6312
589	346921	204336469	24.2693	8.3825	644	414736	267089984	25.3772	8.6357
590	348100	205379000	24.2899	8.3872	645	416025	268336125	25.3969	8.6401
591	349281	206425071	24.3105	8.3919	646	417316	269586136	25.4165	8.6446
592	350464	207474688	24.3311	8.3967	647	418609	270840023	25.4362	8.6490
593	351649	208527857	24.3516	8.4014	648	419904	272097792	25.4558	8.6535
594	352836	209584584	24.3721	8.4061	649	421201	273359449	25.4755	8.6579

No.	Square.	Cube.	Sq. Root.	Cube Root.	No.	Square	Cube.	Sq. Root.	Cube Root.
650	422500	274625000	25.4951	8.6624	705	497025	350402625	26.5518	8.9001
651	423801	275894451	25.5147	8.6668	706	498436	351895816	26.5707	8.9043
652	425104	277167808	25.5343	8.6713	707	499849	353393243	26.5895	8.9085
653	426409	278445077	25.5539	8.6757	708	501264	354894912	26.6083	8.9127
654	427716	279726264	25.5734	8.6801	709	502681	356400829	26.6271	8.9169
655	429025	281011375	25.5930	8.6845	710	504100	357911000	26.6458	8.9211
656	430336	282300416	25.6125	8.6890	711	505521	359425431	26.6646	8.9253
657	431649	283593393	25.6320	8.6934	712	506944	360944128	26.6833	8.9295
658	432964	284890312	25.6515	8.6978	713	508369	362467097	26.7021	8.9337
659	434281	286191179	25.6710	8.7022	714	509796	363994344	26.7208	8.9378
660	435600	287496000	25.6905	8.7066	715	511225	365525875	26.7395	8.9420
661	436921	288804781	25.7099	8.7110	716	512656	367061696	26.7582	8.9462
662	438244	290117528	25.7294	8.7154	717	514089	368601813	26.7769	8.9503
663	439569	291434247	25.7488	8.7198	718	515524	370146232	26.7955	8.9545
664	440896	292754944	25.7682	8.7241	719	516961	371694959	26.8142	8.9587
665	442225	294079625	25.7876	8.7285	720	518400	373248000	26.8328	8.9628
666	443556	295408296	25.8070	8.7329	721	519841	374805361	26.8514	8.9670
667	444889	296740963	25.8263	8.7373	722	521284	376367048	26.8701	8.9711
668	446224	298077632	25.8457	8.7416	723	522729	377933067	26.8887	8.9752
669	447561	299418309	25.8650	8.7460	724	524176	379503424	26.9072	8.9794
670	448900	300763000	25.8844	8.7503	725	525625	381078125	26.9258	8.9835
671	450241	302111711	25.9037	8.7547	726	527076	382657176	26.9444	8.9876
672	451584	303464448	25.9230	8.7590	727	528529	384240583	26.9629	8.9918
673	452929	304821217	25.9422	8.7634	728	529984	385828352	26.9815	8.9959
674	454276	306182024	25.9615	8.7677	729	531441	387420489	27.0000	9.0000
675	455625	307546875	25.9808	8.7721	730	532900	389017000	27.0185	9.0041
676	456976	308915776	26.0000	8.7764	731	534361	390617891	27.0370	9.0082
677	458329	310288733	26.0192	8.7807	732	535824	392223168	27.0555	9.0123
678	459684	311665752	26.0384	8.7850	733	537289	393832837	27.0740	9.0164
679	461041	313046839	26.0576	8.7893	734	538756	395446904	27.0924	9.0205
680	462400	314432000	26.0768	8.7937	735	540225	397065375	27.1109	9.0246
681	463761	315821241	26.0960	8.7980	736	541696	398688256	27.1293	9.0287
682	465124	317214568	26.1151	8.8023	737	543169	400315553	27.1477	9.0328
683	466489	318611987	26.1343	8.8066	738	544644	401947272	27.1662	9.0369
684	467856	320013504	26.1534	8.8109	739	546121	403583419	27.1846	9.0410
685	469225	321419125	26.1725	8.8152	740	547600	405224000	27.2029	9.0450
686	470596	322828856	26.1916	8.8194	741	549081	406869021	27.2213	9.0491
687	471969	324242703	26.2107	8.8237	742	550564	408518488	27.2397	9.0532
688	473344	325660672	26.2298	8.8280	743	552049	410172407	27.2580	9.0572
689	474721	327082769	26.2488	8.8323	744	553536	411830784	27.2764	9.0613
690	476100	328509000	26.2679	8.8366	745	555025	413493625	27.2947	9.0654
691	477481	329939371	26.2869	8.8408	746	556516	415160936	27.3130	9.0694
692	478864	331373888	26.3059	8.8451	747	558009	416832723	27.3313	9.0735
693	480249	332812557	26.3249	8.8493	748	559504	418508992	27.3496	9.0775
694	481636	334255384	26.3439	8.8536	749	561001	420189749	27.3679	9.0816
695	483025	335702375	26.3629	8.8578	750	562500	421875000	27.3861	9.0856
696	484416	337153536	26.3818	8.8621	751	564001	423564751	27.4044	9.0896
697	485809	338608873	26.4008	8.8663	752	565504	425259008	27.4226	9.0937
698	487204	340068392	26.4197	8.8706	753	567009	426957777	27.4408	9.0977
699	488601	341532099	26.4386	8.8748	754	568516	428661064	27.4591	9.1017
700	490000	343000000	26.4575	8.8790	755	570025	430368875	27.4773	9.1057
701	491401	344472101	26.4764	8.8833	756	571536	432081216	27.4955	9.1098
702	492804	345948408	26.4953	8.8875	757	573049	433798093	27.5136	9.1138
703	494209	347428927	26.5141	8.8917	758	574564	435519512	27.5318	9.1178
704	495616	348913664	26.5330	8.8959	759	576081	437245479	27.5500	9.1218



No.	Square.	Cube.	Sq. Root.	Cube Root.	No.	Square	Cube.	Sq. Root.	Cube Root.
760	577600	438976000	27.5681	9.1258	815	664225	541343375	28.5482	9.3408
761	579121	440711081	27.5862	9.1298	816	665856	543338496	28.5657	9.3447
762	580644	442450728	27.6043	9.1338	817	667489	545338513	28.5832	9.3485
763	582169	444194947	27.6225	9.1378	818	669124	547343432	28.6007	9.3523
764	583696	445943744	27.6405	9.1418	819	670761	549353259	28.6182	9.3561
765	585225	447697125	27.6586	9.1458	820	672400	551368000	28.6356	9.3599
766	586756	449455096	27.6767	9.1498	821	674041	553387661	28.6531	9.3637
767	588289	451217663	27.6948	9.1537	822	675684	555412248	28.6705	9.3675
768	589824	452984832	27.7128	9.1577	823	677329	557441767	28.6880	9.3713
769	591361	454756609	27.7308	9.1617	824	678976	559476224	28.7054	9.3751
770	592900	456533000	27.7489	9.1657	825	680625	561515625	28.7228	9.3789
771	594441	458314011	27.7669	9.1696	826	682276	563559976	28.7402	9.3827
772	595984	460099648	27.7849	9.1736	827	683929	565609283	28.7576	9.3865
773	597529	461889917	27.8029	9.1775	828	685584	567663552	28.7750	9.3902
774	599076	463684824	27.8209	9.1815	829	687241	569722789	28.7924	9.3940
775	600625	465484375	27.8388	9.1855	830	688900	571787000	28.8097	9.3978
776	602176	467288576	27.8568	9.1894	831	690561	573856191	28.8271	9.4016
777	603729	469097433	27.8747	9.1933	832	692224	575930368	28.8444	9.4053
778	605284	470910952	27.8927	9.1973	833	693889	578009537	28.8617	9.4091
779	606841	472729139	27.9106	9.2012	834	695556	580093704	28.8791	9.4129
780	608400	474552000	27.9285	9.2052	835	697225	582182875	28.8964	9.4166
781	609961	476379541	27.9464	9.2091	836	698896	584277056	28.9137	9.4204
782	611524	478211768	27.9643	9.2130	837	700569	586376253	28.9310	9.4241
783	613089	480048687	27.9821	9.2170	838	702244	588480472	28.9482	9.4279
784	614656	481890304	28.0000	9.2209	839	703921	590589719	28.9655	9.4316
785	616225	483736625	28.0179	9.2248	840	705600	592704000	28.9828	9.4354
786	617796	485587656	28.0357	9.2287	841	707281	594823321	29.0000	9.4391
787	619369	487443403	28.0535	9.2326	842	708964	596947688	29.0172	9.4429
788	620944	489303872	28.0713	9.2365	843	710649	599077107	29.0345	9.4466
789	622521	491169069	28.0891	9.2404	844	712336	601211584	29.0517	9.4503
790	624100	493039000	28.1069	9.2443	845	714025	603351125	29.0689	9.4541
791	625681	494913671	28.1247	9.2482	846	715716	605495736	29.0861	9.4578
792	627264	496793088	28.1425	9.2521	847	717409	607645423	29.1033	9.4615
793	628849	498677257	28.1603	9.2560	848	719104	609800192	29.1204	9.4652
794	630436	500566184	28.1780	9.2599	849	720801	611960049	29.1376	9.4690
795	632025	502459875	28.1957	9.2638	850	722500	614125000	29.1548	9.4727
796	633616	504358336	28.2135	9.2677	851	724201	616295051	29.1719	9.4764
797	635209	506261573	28.2312	9.2716	852	725904	618470208	29.1890	9.4801
798	636804	508169592	28.2489	9.2754	853	727609	620650477	29.2062	9.4838
799	638401	510082399	28.2666	9.2793	854	729316	622835864	29.2233	9.4875
800	640000	512000000	28.2843	9.2832	855	731025	625026375	29.2404	9.4912
801	641601	513922401	28.3019	9.2870	856	732736	627222016	29.2575	9.4949
802	643204	515849608	28.3196	9.2909	857	734449	629422793	29.2746	9.4986
803	644809	517781627	28.3373	9.2948	858	736164	631628712	29.2916	9.5023
804	646416	519718464	28.3549	9.2986	859	737881	633839779	29.3087	9.5060
805	648025	521660125	28.3725	9.3025	860	739600	636056000	29.3258	9.5097
806	649636	523606616	28.3901	9.3063	861	741321	638277381	29.3428	9.5134
807	651249	525557943	28.4077	9.3102	862	743044	640503928	29.3598	9.5171
808	652864	527514112	28.4253	9.3140	863	744769	642735647	29.3769	9.5207
809	654481	529475129	28.4429	9.3179	864	746496	644972544	29.3939	9.5244
810	656100	531441000	28.4605	9.3217	865	748225	647214625	29.4109	9.5281
811	657721	533411731	28.4781	9.3255	866	749956	649461896	29.4279	9.5317
812	659344	535387328	28.4956	9.3294	867	751689	651714363	29.4449	9.5354
813	660969	537367797	28.5132	9.3332	868	753424	653972032	29.4618	9.5391
814	662596	539353144	28.5307	9.3370	869	755161	656234909	29.4788	9.5427

No.	Square.	Cube.	Sq. Root.	Cube Root.	No.	Square	Cube.	Sq. Root.	Cube Root.
870	756900	658503000	29.4958	9.5464	925	855625	791453125	30.4138	9.7435
871	758641	660776311	29.5127	9.5501	926	857476	794022776	30.4302	9.7470
872	760384	663054848	29.5296	9.5537	927	859329	796597983	30.4467	9.7505
873	762129	665338617	29.5466	9.5574	928	861184	799178752	30.4631	9.7540
874	763876	667627624	29.5635	9.5610	929	863041	801765089	30.4795	9.7575
875	765625	669921875	29.5804	9.5647	930	864900	804357000	30.4959	9.7610
876	767376	672221376	29.5973	9.5683	931	866761	806954491	30.5123	9.7645
877	769129	674526133	29.6142	9.5719	932	868624	809557568	30.5287	9.7680
878	770884	676836152	29.6311	9.5756	933	870489	812166237	30.5450	9.7715
879	772641	679151439	29.6479	9.5792	934	872356	814780504	30.5614	9.7750
880	774400	681472000	29.6648	9.5828	935	874225	817400375	30.5778	9.7785
881	776161	683797841	29.6816	9.5865	936	876096	820025856	30.5941	9.7819
882	777924	686128968	29.6985	9.5901	937	877969	822656953	30.6105	9.7854
883	779689	688465387	29.7153	9.5937	938	879844	825293672	30.6268	9.7889
884	781456	690807104	29.7321	9.5973	939	881721	827936019	30.6431	9.7924
885	783225	693154125	29.7489	9.6010	940	883600	830584000	30.6594	9.7959
886	784996	695506456	29.7658	9.6046	941	885481	833237621	30.6757	9.7993
887	786769	697864103	29.7825	9.6082	942	887364	835896888	30.6920	9.8028
888	788544	700227072	29.7993	9.6118	943	889249	838561807	30.7083	9.8063
889	790321	702595369	29.8161	9.6154	944	891136	841232384	30.7246	9.8097
890	792100	704969000	29.8329	9.6190	945	893025	843908625	30.7409	9.8132
891	793881	707347971	29.8496	9.6226	946	894916	846590536	30.7571	9.8167
892	795664	709732288	29.8664	9.6262	947	896809	849278123	30.7734	9.8201
893	797449	712121957	29.8831	9.6298	948	898704	851971392	30.7896	9.8236
894	799236	714516984	29.8998	9.6334	949	900601	854670349	30.8058	9.8270
895	801025	716917375	29.9166	9.6370	950	902500	857375000	30.8221	9.8305
896	802816	719323136	29.9333	9.6406	951	904401	860085351	30.8383	9.8339
897	804609	721734273	29.9500	9.6442	952	906304	862801408	30.8545	9.8374
898	806404	724150792	29.9666	9.6477	953	908209	865523177	30.8707	9.8408
899	808201	726572699	29.9833	9.6513	954	910116	868250664	30.8869	9.8443
900	810000	729000000	30.0000	9.6549	955	912025	870983875	30.9031	9.8477
901	811801	731432701	30.0167	9.6585	956	913936	873722816	30.9192	9.8511
902	813604	733870808	30.0333	9.6620	957	915849	876467493	30.9354	9.8546
903	815409	736314327	30.0500	9.6656	958	917764	879217912	30.9516	9.8580
904	817216	738763264	30.0666	9.6692	959	919681	881974079	30.9677	9.8614
905	819025	741217625	30.0832	9.6727	960	921600	884736000	30.9839	9.8648
906	820836	743677416	30.0998	9.6763	961	923521	887503681	31.0000	9.8683
907	822649	746142643	30.1164	9.6799	962	925444	890277128	31.0161	9.8717
908	824464	748613312	30.1330	9.6834	963	927369	893056347	31.0322	9.8751
909	826281	751089429	30.1496	9.6870	964	929296	895841344	31.0483	9.8785
910	828100	753571000	30.1662	9.6905	965	931225	898632125	31.0644	9.8819
911	829921	756058031	30.1828	9.6941	966	933156	901428696	31.0805	9.8854
912	831744	758550528	30.1993	9.6976	967	935089	904231063	31.0966	9.8888
913	833569	761048497	30.2159	9.7012	968	937024	907039232	31.1127	9.8922
914	835396	763551944	30.2324	9.7047	969	938961	909853209	31.1288	9.8956
915	837225	766060875	30.2490	9.7082	970	940900	912673000	31.1448	9.8990
916	839056	768575296	30.2655	9.7118	971	942841	915498611	31.1609	9.9024
917	840889	771095213	30.2820	9.7153	972	944784	918330048	31.1769	9.9058
918	842724	773620632	30.2985	9.7188	973	946729	921167317	31.1929	9.9092
919	844561	776151559	30.3150	9.7224	974	948676	924010424	31.2090	9.9126
920	846400	778688000	30.3315	9.7259	975	950625	926859375	31.2250	9.9160
921	848241	781229961	30.3480	9.7294	976	952576	929714176	31.2410	9.9194
922	850084	783777448	30.3645	9.7329	977	954529	932574833	31.2570	9.9227
923	851929	786330467	30.3809	9.7364	978	956484	935441352	31.2730	9.9261
924	853776	788889024	30.3974	9.7400	979	958441	938313739	31.2890	9.9295



No.	Square.	Cube.	Sq. Root.	Cube Root.	No.	Square.	Cube.	Sq. Root.	Cube Root.
980	960400	941192000	31,3050	9,9329	1035	1071225	1108717875	32,1714	10,1153
981	962361	944076141	31,3209	9,9363	1036	1073296	1111934656	32,1870	10,1186
982	964324	946966168	31,3369	9,9396	1037	1075369	1115157653	32,2025	10,1218
983	966289	949862087	31,3528	9,9430	1038	1077444	1118386872	32,2180	10,1251
984	968256	952763904	31,3688	9,9464	1039	1079521	1121622319	32,2335	10,1283
985	970225	955671625	31,3847	9,9497	1040	1081600	1124864000	32,2490	10,1316
986	972196	958585256	31,4006	9,9531	1041	1083681	1128111921	32,2645	10,1348
987	974169	961504803	31,4166	9,9565	1042	1085764	1131366088	32,2800	10,1381
988	976144	964430272	31,4325	9,9598	1043	1087849	1134626507	32,2955	10,1413
989	978121	967361569	31,4484	9,9632	1044	1089936	1137893184	32,3110	10,1446
990	980100	970299000	31,4643	9,9666	1045	1092025	1141166125	32,3265	10,1478
991	982081	973242271	31,4802	9,9699	1046	1094116	1144445336	32,3419	10,1510
992	984064	976191488	31,4960	9,9733	1047	1096209	1147730823	32,3574	10,1543
993	986049	979146657	31,5119	9,9766	1048	1098304	1151022592	32,3728	10,1575
994	988036	982107784	31,5278	9,9800	1049	1100401	1154320649	32,3883	10,1607
995	990025	985074875	31,5436	9,9833	1050	1102500	1157625000	32,4037	10,1640
996	992016	988047936	31,5595	9,9866	1051	1104601	1160935651	32,4191	10,1672
997	994009	991026973	31,5753	9,9900	1052	1106704	1164252608	32,4345	10,1704
998	996004	994011992	31,5911	9,9933	1053	1108809	1167575877	32,4500	10,1736
999	998001	997002999	31,6070	9,9967	1054	1110916	1170905464	32,4654	10,1769
1000	1000000	1000000000	31,6228	10,0000	1055	1113025	1174241375	32,4808	10,1801
1001	1002001	1003003001	31,6386	10,0033	1056	1115136	1177583616	32,4962	10,1833
1002	1004004	1006012008	31,6544	10,0067	1057	1117249	1180932193	32,5115	10,1865
1003	1006009	1009027027	31,6702	10,0100	1058	1119364	1184287112	32,5269	10,1897
1004	1008016	1012048064	31,6860	10,0133	1059	1121481	1187648379	32,5423	10,1929
1005	1010025	1015075125	31,7017	10,0166	1060	1123600	1191016000	32,5576	10,1961
1006	1012036	1018108216	31,7175	10,0200	1061	1125721	1194389981	32,5730	10,1993
1007	1014049	1021147343	31,7333	10,0233	1062	1127844	1197770328	32,5883	10,2025
1008	1016064	1024192512	31,7490	10,0266	1063	1129969	1201157047	32,6036	10,2057
1009	1018081	1027243729	31,7648	10,0299	1064	1132096	1204550144	32,6190	10,2089
1010	1020100	1030301000	31,7805	10,0332	1065	1134225	1207949625	32,6343	10,2121
1011	1022121	1033364331	31,7962	10,0365	1066	1136356	1211355496	32,6497	10,2153
1012	1024144	1036433728	31,8119	10,0398	1067	1138489	1214767763	32,6650	10,2185
1013	1026169	1039509197	31,8277	10,0431	1068	1140624	1218186432	32,6803	10,2217
1014	1028196	1042590744	31,8434	10,0465	1069	1142761	1221611509	32,6956	10,2249
1015	1030225	1045678375	31,8591	10,0498	1070	1144900	1225043000	32,7109	10,2281
1016	1032256	1048772096	31,8748	10,0531	1071	1147041	1228480911	32,7261	10,2313
1017	1034289	1051871913	31,8904	10,0563	1072	1149184	1231925248	32,7414	10,2345
1018	1036324	1054977832	31,9061	10,0596	1073	1151329	1235376017	32,7567	10,2376
1019	1038361	1058089859	31,9218	10,0629	1074	1153476	1238833224	32,7719	10,2408
1020	1040400	1061208000	31,9374	10,0662	1075	1155625	1242296875	32,7872	10,2440
1021	1042441	1064332261	31,9531	10,0695	1076	1157776	1245766976	32,8024	10,2472
1022	1044484	1067462648	31,9687	10,0728	1077	1159929	1249243533	32,8177	10,2503
1023	1046529	1070599167	31,9844	10,0761	1078	1162084	1252726552	32,8329	10,2535
1024	1048576	1073741824	32,0000	10,0794	1079	1164241	1256216039	32,8481	10,2567
1025	1050625	1076890625	32,0156	10,0826	1080	1166400	1259712000	32,8634	10,2599
1026	1052676	1080045576	32,0312	10,0859	1081	1168561	1263214441	32,8786	10,2630
1027	1054729	1083206683	32,0468	10,0892	1082	1170724	1266723368	32,8938	10,2662
1028	1056784	1086373952	32,0624	10,0925	1083	1172889	1270238787	32,9090	10,2693
1029	1058841	1089547389	32,0780	10,0957	1084	1175056	1273760704	32,9242	10,2725
1030	1060900	1092727000	32,0936	10,0990	1085	1177225	1277289125	32,9393	10,2757
1031	1062961	1095912791	32,1092	10,1023	1086	1179396	1280824056	32,9545	10,2788
1032	1065024	1099104768	32,1248	10,1055	1087	1181569	1284365503	32,9697	10,2820
1033	1067089	1102302937	32,1403	10,1088	1088	1183744	1287913472	32,9848	10,2851
1034	1069156	1105507304	32,1559	10,1121	1089	1185921	1291467969	33,0000	10,2883

No.	Square.	Cube.	Sq. Root.	Cube Root.	No.	Square.	Cube.	Sq. Root.	Cube Root.
1090	1188100	1295029000	33.0151	10.2914	1145	1311025	1501123625	33.8378	10.4617
1091	1190281	1298596571	33.0303	10.2946	1146	1313316	1505060136	33.8526	10.4647
1092	1192464	1302170688	33.0454	10.2977	1147	1315609	1509003523	33.8674	10.4678
1093	1194649	1305751357	33.0606	10.3009	1148	1317904	1512953792	33.8821	10.4708
1094	1196836	1309338584	33.0757	10.3040	1149	1320201	1516910949	33.8969	10.4739
1095	1199025	1312932375	33.0908	10.3071	1150	1322500	1520875000	33.9116	10.4769
1096	1201216	1316532736	33.1059	10.3103	1151	1324801	1524845951	33.9264	10.4799
1097	1203409	1320139673	33.1210	10.3134	1152	1327104	1528823808	33.9411	10.4830
1098	1205604	1323753192	33.1361	10.3165	1153	1329409	1532808577	33.9559	10.4860
1099	1207801	1327373299	33.1512	10.3197	1154	1331716	1536800264	33.9706	10.4890
1100	1210000	1331000000	33.1662	10.3228	1155	1334025	1540798875	33.9853	10.4921
1101	1212201	1334633301	33.1813	10.3259	1156	1336336	1544804416	34.0000	10.4951
1102	1214404	1338273208	33.1964	10.3290	1157	1338649	1548816893	34.0147	10.4981
1103	1216609	1341919727	33.2114	10.3322	1158	1340964	1552836312	34.0294	10.5011
1104	1218816	1345572864	33.2264	10.3353	1159	1343281	1556862679	34.0441	10.5042
1105	1221025	1349232625	33.2415	10.3384	1160	1345600	1560896000	34.0588	10.5072
1106	1223236	1352899016	33.2566	10.3415	1161	1347921	1564936281	34.0735	10.5102
1107	1225449	1356572043	33.2716	10.3447	1162	1350244	1568983528	34.0881	10.5132
1108	1227664	1360251712	33.2866	10.3478	1163	1352569	1573037747	34.1028	10.5162
1109	1229881	1363938029	33.3017	10.3509	1164	1354896	1577098944	34.1174	10.5192
1110	1232100	1367631000	33.3167	10.3540	1165	1357225	1581167125	34.1321	10.5223
1111	1234321	1371330631	33.3317	10.3571	1166	1359556	1585242296	34.1467	10.5253
1112	1236544	1375036928	33.3467	10.3602	1167	1361889	1589324463	34.1614	10.5283
1113	1238769	1378749897	33.3617	10.3633	1168	1364224	1593413632	34.1760	10.5313
1114	1240996	1382469544	33.3766	10.3664	1169	1366561	1597509809	34.1906	10.5343
1115	1243225	1386195875	33.3916	10.3695	1170	1368900	1601613000	34.2053	10.5373
1116	1245456	1389928896	33.4066	10.3726	1171	1371241	1605723211	34.2199	10.5403
1117	1247689	1393668613	33.4215	10.3757	1172	1373584	1609840448	34.2345	10.5433
1118	1249924	1397415032	33.4365	10.3788	1173	1375929	1613964717	34.2491	10.5463
1119	1252161	1401168159	33.4515	10.3819	1174	1378276	1618096024	34.2637	10.5493
1120	1254400	1404928000	33.4664	10.3850	1175	1380625	1622234375	34.2783	10.5523
1121	1256641	1408694561	33.4813	10.3881	1176	1382976	1626379776	34.2929	10.5553
1122	1258884	1412467848	33.4963	10.3912	1177	1385329	1630532233	34.3074	10.5583
1123	1261129	1416247867	33.5112	10.3943	1178	1387684	1634691752	34.3220	10.5612
1124	1263376	1420034624	33.5261	10.3973	1179	1390041	1638858339	34.3366	10.5642
1125	1265625	1423828125	33.5410	10.4004	1180	1392400	1643032000	34.3511	10.5672
1126	1267876	1427628376	33.5559	10.4035	1181	1394761	1647212741	34.3657	10.5702
1127	1270129	1431435383	33.5708	10.4066	1182	1397124	1651400568	34.3802	10.5732
1128	1272384	1435249152	33.5857	10.4097	1183	1399489	1655595487	34.3948	10.5762
1129	1274641	1439069689	33.6006	10.4127	1184	1401856	1659797504	34.4093	10.5791
1130	1276900	1442897000	33.6155	10.4158	1185	1404225	1664006625	34.4238	10.5821
1131	1279161	1446731091	33.6303	10.4189	1186	1406596	1668228256	34.4384	10.5851
1132	1281424	1450571968	33.6452	10.4219	1187	1408969	1672446203	34.4529	10.5881
1133	1283689	1454419637	33.6601	10.4250	1188	1411344	1676676672	34.4674	10.5910
1134	1285956	1458274104	33.6749	10.4281	1189	1413721	1680914269	34.4819	10.5940
1135	1288225	1462135375	33.6898	10.4311	1190	1416100	1685159000	34.4964	10.5970
1136	1290496	1466003456	33.7046	10.4342	1191	1418481	1689410871	34.5109	10.6000
1137	1292769	1469878353	33.7194	10.4373	1192	1420864	1693669888	34.5254	10.6029
1138	1295044	1473760072	33.7342	10.4404	1193	1423249	1697936057	34.5398	10.6059
1139	1297321	1477648619	33.7491	10.4434	1194	1425636	1702209384	34.5543	10.6088
1140	1299600	1481544000	33.7639	10.4464	1195	1428025	1706489875	34.5688	10.6118
1141	1301881	1485446221	33.7787	10.4495	1196	1430416	1710777536	34.5832	10.6148
1142	1304164	1489355288	33.7935	10.4525	1197	1432809	1715072373	34.5977	10.6177
1143	1306449	1493271207	33.8083	10.4556	1198	1435204	1719374392	34.6121	10.6207
1144	1308736	1497193984	33.8231	10.4586	1199	1437601	1723683599	34.6266	10.6236



No.	Square.	Cube.	Sq. Root.	Cube Root.	No.	Square.	Cube.	Sq. Root.	Cube Root.
1200	1440000	1728000000	34.6410	10.6266	1255	1575025	1976656375	35.4260	10.7865
1201	1442401	1732323601	34.6554	10.6295	1256	1577536	1981385216	35.4401	10.7894
1202	1444804	1736654408	34.6699	10.6325	1257	1580049	1986121593	35.4542	10.7922
1203	1447209	1740992427	34.6843	10.6354	1258	1582564	1990865512	35.4683	10.7951
1204	1449616	1745337664	34.6987	10.6384	1259	1585081	1995616979	35.4824	10.7980
1205	1452025	1749690125	34.7131	10.6413	1260	1587600	2000376000	35.4965	10.8008
1206	1454436	1754049816	34.7275	10.6443	1261	1590121	2005142581	35.5106	10.8037
1207	1456849	1758416743	34.7419	10.6472	1262	1592644	2009916728	35.5246	10.8065
1208	1459264	1762790912	34.7563	10.6501	1263	1595169	2014698447	35.5387	10.8094
1209	1461681	1767172329	34.7707	10.6530	1264	1597696	2019487744	35.5528	10.8122
1210	1464100	1771561000	34.7851	10.6560	1265	1600225	2024284625	35.5668	10.8151
1211	1466521	1775956931	34.7994	10.6590	1266	1602756	2029089096	35.5809	10.8179
1212	1468944	1780360128	34.8138	10.6619	1267	1605289	2033901163	35.5949	10.8208
1213	1471369	1784770597	34.8281	10.6648	1268	1607824	2038720832	35.6090	10.8236
1214	1473796	1789188344	34.8425	10.6678	1269	1610361	2043548109	35.6230	10.8265
1215	1476225	1793613375	34.8569	10.6707	1270	1612900	2048383000	35.6371	10.8293
1216	1478656	1798045696	34.8712	10.6736	1271	1615441	2053225511	35.6511	10.8322
1217	1481089	1802485313	34.8855	10.6765	1272	1617984	2058075648	35.6651	10.8350
1218	1483524	1806932232	34.8999	10.6795	1273	1620529	2062933417	35.6791	10.8378
1219	1485961	1811386459	34.9142	10.6824	1274	1623076	2067798824	35.6931	10.8407
1220	1488400	1815848000	34.9285	10.6853	1275	1625625	2072671875	35.7071	10.8435
1221	1490841	1820316861	34.9428	10.6882	1276	1628176	2077552576	35.7211	10.8463
1222	1493284	1824793048	34.9571	10.6911	1277	1630729	2082440933	35.7351	10.8492
1223	1495729	1829276567	34.9714	10.6940	1278	1633284	2087336952	35.7491	10.8520
1224	1498176	1833767424	34.9857	10.6970	1279	1635841	2092240639	35.7631	10.8548
1225	1500625	1838265625	35.0000	10.6999	1280	1638400	2097152000	35.7771	10.8577
1226	1503076	1842771176	35.0143	10.7028	1281	1640961	2102071041	35.7911	10.8605
1227	1505529	1847284083	35.0286	10.7057	1282	1643524	2106997768	35.8050	10.8633
1228	1507984	1851804352	35.0428	10.7086	1283	1646089	2111932187	35.8190	10.8661
1229	1510441	1856331989	35.0571	10.7115	1284	1648656	2116874304	35.8329	10.8690
1230	1512900	1860867000	35.0714	10.7144	1285	1651225	2121824125	35.8469	10.8718
1231	1515361	1865409391	35.0856	10.7173	1286	1653796	2126781656	35.8608	10.8746
1232	1517824	1869959168	35.0999	10.7202	1287	1656369	2131746903	35.8748	10.8774
1233	1520289	1874516337	35.1141	10.7231	1288	1658944	2136719872	35.8887	10.8802
1234	1522756	1879080904	35.1283	10.7260	1289	1661521	2141700569	35.9026	10.8831
1235	1525225	1883652875	35.1426	10.7289	1290	1664100	2146689000	35.9166	10.8859
1236	1527696	1888232256	35.1568	10.7318	1291	1666681	2151685171	35.9305	10.8887
1237	1530169	1892819053	35.1710	10.7347	1292	1669264	2156689088	35.9444	10.8915
1238	1532644	1897413272	35.1852	10.7376	1293	1671849	2161700757	35.9583	10.8943
1239	1535121	1902014919	35.1994	10.7405	1294	1674436	2166720184	35.9722	10.8971
1240	1537600	1906624000	35.2136	10.7434	1295	1677025	2171747375	35.9861	10.8999
1241	1540081	1911240521	35.2278	10.7463	1296	1679616	2176782336	36.0000	10.9027
1242	1542564	1915864488	35.2420	10.7491	1297	1682209	2181825073	36.0139	10.9055
1243	1545049	1920495907	35.2562	10.7520	1298	1684804	2186875592	36.0278	10.9083
1244	1547536	1925134784	35.2704	10.7549	1299	1687401	2191933899	36.0416	10.9111
1245	1550025	1929781125	35.2846	10.7578	1300	1690000	2197000000	36.0555	10.9139
1246	1552516	1934434936	35.2987	10.7607	1301	1692601	2202073901	36.0694	10.9167
1247	1555009	1939096223	35.3129	10.7635	1302	1695204	2207155608	36.0832	10.9195
1248	1557504	1943764992	35.3270	10.7664	1303	1697809	2212245127	36.0971	10.9223
1249	1560001	1948441249	35.3412	10.7693	1304	1700416	2217342464	36.1109	10.9251
1250	1562500	1953125000	35.3553	10.7722	1305	1703025	2222447625	36.1248	10.9279
1251	1565001	1957816251	35.3695	10.7750	1306	1705636	2227560616	36.1386	10.9307
1252	1567504	1962515008	35.3836	10.7779	1307	1708249	2232681443	36.1525	10.9335
1253	1570009	1967221277	35.3977	10.7808	1308	1710864	2237810112	36.1663	10.9363
1254	1572516	1971935064	35.4119	10.7837	1309	1713481	2242946629	36.1801	10.9391

No.	Square.	Cube.	Sq. Root.	Cube Root.	No.	Square.	Cube.	Sq. Root.	Cube Root.
1310	1716100	2248091000	36.1939	10.9418	1365	1863225	2543302125	36.9459	11.0929
1311	1718721	2253243231	36.2077	10.9446	1366	1865956	2548895896	36.9594	11.0956
1312	1721344	2258403328	36.2215	10.9474	1367	1868687	2554497863	36.9730	11.0983
1313	1723969	2263571297	36.2353	10.9502	1368	1871424	2560108032	36.9865	11.1010
1314	1726596	2268747144	36.2491	10.9530	1369	1874161	2565726409	37.0000	11.1037
1315	1729225	2273930875	36.2629	10.9557	1370	1876900	2571353000	37.0135	11.1064
1316	1731856	2279122496	36.2767	10.9585	1371	1879641	2576987811	37.0270	11.1091
1317	1734489	2284322013	36.2905	10.9613	1372	1882384	2582630848	37.0405	11.1118
1318	1737124	2289529432	36.3043	10.9640	1373	1885129	2588282117	37.0540	11.1145
1319	1739761	2294744759	36.3180	10.9668	1374	1887876	2593941624	37.0675	11.1172
1320	1742400	2299968000	36.3318	10.9696	1375	1890625	2599609375	37.0810	11.1199
1321	1745041	2305199161	36.3456	10.9724	1376	1893376	2605285376	37.0945	11.1226
1322	1747684	2310438248	36.3593	10.9752	1377	1896129	2610969633	37.1080	11.1253
1323	1750329	2315685267	36.3731	10.9779	1378	1898884	2616662152	37.1214	11.1280
1324	1752976	2320940224	36.3868	10.9807	1379	1901641	2622362939	37.1349	11.1307
1325	1755625	2326203125	36.4005	10.9834	1380	1904400	2628072000	37.1484	11.1334
1326	1758276	2331473976	36.4143	10.9862	1381	1907161	2633789341	37.1618	11.1361
1327	1760929	2336752783	36.4280	10.9890	1382	1909924	2639514968	37.1753	11.1387
1328	1763584	2342039552	36.4417	10.9917	1383	1912689	2645248887	37.1887	11.1414
1329	1766241	2347334289	36.4555	10.9945	1384	1915456	2650991104	37.2021	11.1441
1330	1768900	2352637000	36.4692	10.9972	1385	1918225	2656741625	37.2156	11.1468
1331	1771561	2357947691	36.4829	11.0000	1386	1920996	2662500456	37.2290	11.1495
1332	1774224	2363266368	36.4966	11.0028	1387	1923769	2668267603	37.2424	11.1522
1333	1776889	2368593037	36.5103	11.0055	1388	1926544	2674043072	37.2559	11.1548
1334	1779556	2373927704	36.5240	11.0083	1389	1929321	2679826869	37.2693	11.1575
1335	1782225	2379270375	36.5377	11.0110	1390	1932100	2685619000	37.2827	11.1602
1336	1784896	2384621056	36.5513	11.0138	1391	1934881	2691419471	37.2961	11.1629
1337	1787569	2389979753	36.5650	11.0165	1392	1937664	2697228288	37.3095	11.1655
1338	1790244	2395346472	36.5787	11.0193	1393	1940449	2703045457	37.3229	11.1682
1339	1792921	2400721219	36.5923	11.0220	1394	1943236	2708870984	37.3363	11.1709
1340	1795600	2406104000	36.6060	11.0247	1395	1946025	2714704875	37.3497	11.1736
1341	1798281	2411494821	36.6197	11.0275	1396	1948816	2720547136	37.3631	11.1762
1342	1800964	2416893688	36.6333	11.0302	1397	1951609	2726397773	37.3765	11.1789
1343	1803649	2422300607	36.6469	11.0330	1398	1954404	2732256792	37.3898	11.1816
1344	1806336	2427715584	36.6606	11.0357	1399	1957201	2738124199	37.4032	11.1842
1345	1809025	2433138625	36.6742	11.0384	1400	1960000	2744000000	37.4166	11.1869
1346	1811716	2438569736	36.6879	11.0412	1401	1962801	2749884201	37.4299	11.1896
1347	1814409	2444008923	36.7015	11.0439	1402	1965604	2755776808	37.4433	11.1922
1348	1817104	2449456192	36.7151	11.0466	1403	1968409	2761677827	37.4566	11.1949
1349	1819801	2454911549	36.7287	11.0494	1404	1971216	2767587264	37.4700	11.1975
1350	1822500	2460375000	36.7423	11.0521	1405	1974025	2773505125	37.4833	11.2002
1351	1825201	2465846551	36.7560	11.0548	1406	1976836	2779431416	37.4967	11.2028
1352	1827904	2471326208	36.7696	11.0575	1407	1979649	2785366143	37.5100	11.2055
1353	1830609	2476813977	36.7831	11.0603	1408	1982464	2791309312	37.5233	11.2082
1354	1833316	2482309864	36.7967	11.0630	1409	1985281	2797260929	37.5366	11.2108
1355	1836025	2487813875	36.8103	11.0657	1410	1988100	2803221000	37.5500	11.2135
1356	1838736	2493326016	36.8239	11.0684	1411	1990921	2809189531	37.5633	11.2161
1357	1841449	2498846293	36.8375	11.0712	1412	1993744	2815166528	37.5766	11.2188
1358	1844164	2504374712	36.8511	11.0739	1413	1996569	2821151997	37.5899	11.2214
1359	1846881	2509911279	36.8646	11.0766	1414	1999396	2827145944	37.6032	11.2240
1360	1849600	2515456000	36.8782	11.0793	1415	2002225	2833148375	37.6165	11.2267
1361	1852321	2521008881	36.8917	11.0820	1416	2005056	2839159296	37.6298	11.2293
1362	1855044	2526569928	36.9053	11.0847	1417	2007889	2845178713	37.6431	11.2320
1363	1857769	2532139147	36.9188	11.0875	1418	2010724	2851206632	37.6563	11.2346
1364	1860496	2537716544	36.9324	11.0902	1419	2013561	2857243059	37.6696	11.2373



No.	Square.	Cube.	Sq. Root.	Cube Root.	No.	Square.	Cube.	Sq. Root.	Cube Root.
1420	2016400	2863288000	37,6829	11,2399	1475	2175625	3209046875	38,4057	11,3832
1421	2019241	2869341461	37,6962	11,2425	1476	2178576	3215578176	38,4187	11,3858
1422	2022084	2875403448	37,7094	11,2452	1477	2181529	3222118333	38,4318	11,3883
1423	2024929	2881473967	37,7227	11,2478	1478	2184484	3228667352	38,4448	11,3909
1424	2027776	2887553024	37,7359	11,2505	1479	2187441	3235225239	38,4578	11,3935
1425	2030625	2893640625	37,7492	11,2531	1480	2190400	3241792000	38,4708	11,3960
1426	2033476	2899736776	37,7624	11,2557	1481	2193361	3248367641	38,4838	11,3986
1427	2036329	2905841483	37,7757	11,2583	1482	2196324	3254952168	38,4968	11,4012
1428	2039184	2911954752	37,7889	11,2610	1483	2199289	3261545587	38,5097	11,4037
1429	2042041	2918076589	37,8021	11,2636	1484	2202256	3268147904	38,5227	11,4063
1430	2044900	2924207000	37,8153	11,2662	1485	2205225	3274759125	38,5357	11,4089
1431	2047761	2930345991	37,8286	11,2689	1486	2208196	3281379256	38,5487	11,4114
1432	2050624	2936493568	37,8418	11,2715	1487	2211169	3288008303	38,5616	11,4140
1433	2053489	2942649737	37,8550	11,2741	1488	2214144	3294646272	38,5746	11,4165
1434	2056356	2948814504	37,8682	11,2767	1489	2217121	3301293169	38,5876	11,4191
1435	2059225	2954987875	37,8814	11,2793	1490	2220100	3307949000	38,6005	11,4216
1436	2062096	2961169856	37,8946	11,2820	1491	2223081	3314613771	38,6135	11,4242
1437	2064969	2967360453	37,9078	11,2846	1492	2226064	3321287488	38,6264	11,4268
1438	2067844	2973559672	37,9210	11,2872	1493	2229049	3327970157	38,6394	11,4293
1439	2070721	2979767519	37,9342	11,2898	1494	2232036	3334661784	38,6523	11,4319
1440	2073600	2985984000	37,9473	11,2924	1495	2235025	3341362375	38,6652	11,4344
1441	2076481	2992209121	37,9605	11,2950	1496	2238016	3348071936	38,6782	11,4370
1442	2079364	2998442888	37,9737	11,2977	1497	2241009	3354790473	38,6911	11,4395
1443	2082249	3004685307	37,9868	11,3003	1498	2244004	3361517992	38,7040	11,4421
1444	2085136	3010936384	38,0000	11,3029	1499	2247001	3368254499	38,7169	11,4446
1445	2088025	3017196125	38,0132	11,3055	1500	2250000	3375000000	38,7298	11,4471
1446	2090916	3023464536	38,0263	11,3081	1501	2253001	3381754501	38,7427	11,4497
1447	2093809	3029741623	38,0395	11,3107	1502	2256004	3388518008	38,7556	11,4522
1448	2096704	3036027392	38,0526	11,3133	1503	2259009	3395290527	38,7685	11,4548
1449	2099601	3042321849	38,0657	11,3159	1504	2262016	3402072064	38,7814	11,4573
1450	2102500	3048625000	38,0789	11,3185	1505	2265025	3408862625	38,7943	11,4598
1451	2105401	3054936851	38,0920	11,3211	1506	2268036	3415662216	38,8072	11,4624
1452	2108304	3061257408	38,1051	11,3237	1507	2271049	3422470843	38,8201	11,4649
1453	2111209	3067586677	38,1182	11,3263	1508	2274064	3429288512	38,8330	11,4675
1454	2114116	3073924664	38,1314	11,3289	1509	2277081	3436115229	38,8458	11,4700
1455	2117025	3080271375	38,1445	11,3315	1510	2280100	3442951000	38,8587	11,4725
1456	2119936	3086626816	38,1576	11,3341	1511	2283121	3449795831	38,8716	11,4751
1457	2122849	3092990993	38,1707	11,3367	1512	2286144	3456649728	38,8844	11,4776
1458	2125764	3099363912	38,1838	11,3393	1513	2289169	3463512697	38,8973	11,4801
1459	2128681	3105745579	38,1969	11,3419	1514	2292196	3470384744	38,9102	11,4826
1460	2131600	3112136000	38,2099	11,3445	1515	2295225	3477265875	38,9230	11,4852
1461	2134521	3118535181	38,2230	11,3471	1516	2298256	3484156096	38,9358	11,4877
1462	2137444	3124943128	38,2361	11,3496	1517	2301289	3491055413	38,9487	11,4902
1463	2140369	3131359847	38,2492	11,3522	1518	2304324	3497963832	38,9615	11,4927
1464	2143296	3137785344	38,2623	11,3548	1519	2307361	3504881359	38,9744	11,4953
1465	2146225	3144219625	38,2753	11,3574	1520	2310400	3511808000	38,9872	11,4978
1466	2149156	3150662696	38,2884	11,3600	1521	2313441	3518743761	39,0000	11,5003
1467	2152089	3157114563	38,3014	11,3626	1522	2316484	3525688648	39,0128	11,5028
1468	2155024	3163575232	38,3145	11,3652	1523	2319529	3532642667	39,0256	11,5054
1469	2157961	3170044709	38,3275	11,3677	1524	2322576	3539605824	39,0384	11,5079
1470	2160900	3176523000	38,3406	11,3703	1525	2325625	3546578125	39,0512	11,5104
1471	2163841	3183010111	38,3536	11,3729	1526	2328676	3553559576	39,0640	11,5129
1472	2166784	3189506048	38,3667	11,3755	1527	2331729	3560550183	39,0768	11,5154
1473	2169729	3196010817	38,3797	11,3780	1528	2334784	3567549952	39,0896	11,5179
1474	2172676	3202524424	38,3927	11,3806	1529	2337841	3574558889	39,1024	11,5204

No.	Square.	Cube.	Sq. Root.	Cube Root.	No.	Square.	Cube.	Sq. Root.	Cube Root.
1530	2340900	3581577000	39.1152	11.5230	1565	2449225	3833037125	39.5601	11.6102
1531	2343961	3588604291	39.1280	11.5255	1566	2452356	3840389496	39.5727	11.6126
1532	2347024	3595640768	39.1408	11.5280	1567	2455489	3847751263	39.5854	11.6151
1533	2350089	3602686437	39.1535	11.5305	1568	2458624	3855123432	39.5980	11.6176
1534	2353156	3609741304	39.1663	11.5330	1569	2461761	3862503009	39.6106	11.6200
1535	2356225	3616805375	39.1791	11.5355	1570	2464900	3869893000	39.6232	11.6225
1536	2359296	3623878656	39.1918	11.5380	1571	2468041	3877292411	39.6358	11.6250
1537	2362369	3630961153	39.2046	11.5405	1572	2471184	3884701248	39.6485	11.6274
1538	2365444	3638052872	39.2173	11.5430	1573	2474329	3892119517	39.6611	11.6299
1539	2368521	3645153819	39.2301	11.5455	1574	2477476	3899547224	39.6737	11.6324
1540	2371600	3652264000	39.2428	11.5480	1575	2480625	3906984375	39.6863	11.6348
1541	2374681	3659383421	39.2556	11.5505	1576	2483776	3914430976	39.6989	11.6373
1542	2377764	3666512088	39.2683	11.5530	1577	2486929	3921887033	39.7115	11.6398
1543	2380849	3673650007	39.2810	11.5555	1578	2490084	3929352552	39.7240	11.6422
1544	2383936	3680797184	39.2938	11.5580	1579	2493241	3936827539	39.7366	11.6447
1545	2387025	3687953625	39.3065	11.5605	1580	2496400	3944312000	39.7492	11.6471
1546	2390116	3695119336	39.3192	11.5630	1581	2499561	3951805941	39.7618	11.6496
1547	2393209	3702294323	39.3319	11.5655	1582	2502724	3959309368	39.7744	11.6520
1548	2396304	3709478592	39.3446	11.5680	1583	2505889	3966822287	39.7869	11.6545
1549	2399401	3716672149	39.3573	11.5705	1584	2509056	3974344704	39.7995	11.6570
1550	2402500	3723875000	39.3700	11.5729	1585	2512225	3981876625	39.8121	11.6594
1551	2405601	3731087151	39.3827	11.5754	1586	2515396	3989418056	39.8246	11.6619
1552	2408704	3738308608	39.3954	11.5779	1587	2518569	3996969003	39.8372	11.6643
1553	2411809	3745539377	39.4081	11.5804	1588	2521744	4004529472	39.8497	11.6668
1554	2414916	3752779464	39.4208	11.5829	1589	2524921	4012099469	39.8623	11.6692
1555	2418025	3760028875	39.4335	11.5854	1590	2528100	4019679000	39.8748	11.6717
1556	2421136	3767287616	39.4462	11.5879	1591	2531281	4027268071	39.8873	11.6741
1557	2424249	3774555693	39.4588	11.5903	1592	2534464	4034866688	39.8999	11.6765
1558	2427364	3781833112	39.4715	11.5928	1593	2537649	4042474857	39.9124	11.6790
1559	2430481	3789119879	39.4842	11.5953	1594	2540836	4050092584	39.9249	11.6814
1560	2433600	3796416000	39.4968	11.5978	1595	2544025	4057719875	39.9375	11.6839
1561	2436721	3803721481	39.5095	11.6003	1596	2547216	4065356736	39.9500	11.6863
1562	2439844	3811036328	39.5221	11.6027	1597	2550409	4073003173	39.9625	11.6888
1563	2442969	3818360547	39.5348	11.6052	1598	2553604	4080659192	39.9750	11.6912
1564	2446096	3825694144	39.5474	11.6077	1599	2556801	4088324799	39.9875	11.6936
					1600	2560000	4096000000	40.0000	11.6961

## SQUARES AND CUBES OF DECIMALS.

No.	Square	Cube.	No.	Square	Cube.	No.	Square.	Cube.
.1	.01	.001	.01	.0001	.000 001	.001	.00 00 01	.000 000 001
.2	.04	.008	.02	.0004	.000 008	.002	.00 00 04	.000 000 008
.3	.09	.027	.03	.0009	.000 027	.003	.00 00 09	.000 000 027
.4	.16	.064	.04	.0016	.000 064	.004	.00 00 16	.000 000 064
.5	.25	.125	.05	.0025	.000 125	.005	.00 00 25	.000 000 125
.6	.36	.216	.06	.0036	.000 216	.006	.00 00 36	.000 000 216
.7	.49	.343	.07	.0049	.000 343	.007	.00 00 49	.000 000 343
.8	.64	.512	.08	.0064	.000 512	.008	.00 00 64	.000 000 512
.9	.81	.729	.09	.0081	.000 729	.009	.00 00 81	.000 000 729
1.0	1.00	1.000	.10	.0100	.001 000	.010	.00 01 00	.000 001 000
1.2	1.44	1.728	.12	.0144	.001 728	.012	.00 01 44	.000 001 728

Note that the square has twice as many decimal places, and the cube three times as many decimal places, as the root.

FIFTH ROOTS AND FIFTH POWERS.

(Abridged from TRAUTWINE.)

No. or Root.	Power.	No. or Root.	Power.	No. or Root.	Power.	No. or Root.	Power.	No. or Root.	Power.
.10	.000010	3.7	693.440	9.8	90392	21.8	4923597	40	102400000
.15	.000075	3.8	792.352	9.9	95099	22.0	5153632	41	115856201
.20	.000320	3.9	902.242	10.0	100000	22.2	5392186	42	130691232
.25	.000977	4.0	1024.00	10.2	110408	22.4	5639493	43	147008443
.30	.002430	4.1	1158.56	10.4	121665	22.6	5895793	44	164916224
.35	.005252	4.2	1306.91	10.6	133823	22.8	6161327	45	184528125
.40	.010240	4.3	1470.08	10.8	146933	23.0	6436343	46	205962976
.45	.018453	4.4	1649.16	11.0	161051	23.2	6721093	47	229345007
.50	.031250	4.5	1845.28	11.2	176234	23.4	7015834	48	254803968
.55	.050328	4.6	2059.63	11.4	192541	23.6	7320825	49	282475249
.60	.077760	4.7	2293.45	11.6	210034	23.8	7636332	50	312500000
.65	.116029	4.8	2548.04	11.8	228776	24.0	7962624	51	345025251
.70	.168070	4.9	2824.75	12.0	248832	24.2	8299976	52	380204032
.75	.237305	5.0	3125.00	12.2	270271	24.4	8648666	53	418195493
.80	.327680	5.1	3450.25	12.4	293163	24.6	9008978	54	459165024
.85	.443705	5.2	3802.04	12.6	317580	24.8	9381200	55	503284375
.90	.590490	5.3	4181.95	12.8	343597	25.0	9765625	56	550731776
.95	.773781	5.4	4591.65	13.0	371293	25.2	10162550	57	601692057
1.00	1.00000	5.5	5032.84	13.2	400746	25.4	10572278	58	656356768
1.05	1.27628	5.6	5507.32	13.4	432040	25.6	10995116	59	714924299
1.10	1.61051	5.7	6016.92	13.6	465259	25.8	11431377	60	777600000
1.15	2.01135	5.8	6563.57	13.8	500490	26.0	11881376	61	844596301
1.20	2.48832	5.9	7149.24	14.0	537824	26.2	12345437	62	916132832
1.25	3.05176	6.0	7776.00	14.2	577353	26.4	12823886	63	992436543
1.30	3.71293	6.1	8445.96	14.4	619174	26.6	13317055	64	1073741824
1.35	4.48403	6.2	9161.33	14.6	663383	26.8	13825281	65	1160290625
1.40	5.37824	6.3	9924.37	14.8	710082	27.0	14348907	66	1252332576
1.45	6.40973	6.4	10737	15.0	759375	27.2	14888280	67	1350125107
1.50	7.59375	6.5	11603	15.2	811368	27.4	15443752	68	1453933568
1.55	8.94661	6.6	12523	15.4	866171	27.6	16015681	69	1564031349
1.60	10.4858	6.7	13501	15.6	923896	27.8	16604430	70	1680700000
1.65	12.2298	6.8	14539	15.8	984658	28.0	17210368	71	1804229351
1.70	14.1986	6.9	15640	16.0	1048576	28.2	17833868	72	1934917632
1.75	16.4131	7.0	16807	16.2	1115771	28.4	18475309	73	2073071593
1.80	18.8957	7.1	18042	16.4	1186367	28.6	19135075	74	2219006624
1.85	21.6700	7.2	19349	16.6	1260493	28.8	19813557	75	2373046875
1.90	24.7610	7.3	20731	16.8	1338278	29.0	20511149	76	2535525376
1.95	28.1951	7.4	22190	17.0	1419857	29.2	21228253	77	2706784157
2.00	32.0000	7.5	23730	17.2	1505366	29.4	21965275	78	2887174368
2.05	36.2051	7.6	25355	17.4	1594947	29.6	22722628	79	3077056399
2.10	40.8410	7.7	27068	17.6	1688742	29.8	23500728	80	3276800000
2.15	45.9401	7.8	28872	17.8	1786899	30.0	24300000	81	3486784401
2.20	51.5363	7.9	30771	18.0	1889568	30.5	26393634	82	3707398432
2.25	57.6650	8.0	32768	18.2	1996903	31.0	28629151	83	3939040643
2.30	64.3634	8.1	34868	18.4	2109061	31.5	31013642	84	4182119424
2.35	71.6703	8.2	37074	18.6	2226203	32.0	33554432	85	4437053125
2.40	79.6262	8.3	39390	18.8	2348493	32.5	36259082	86	4704270176
2.45	88.2735	8.4	41821	19.0	2476099	33.0	39135393	87	4984209207
2.50	97.6562	8.5	44371	19.2	2609193	33.5	42191410	88	5277319168
2.55	107.820	8.6	47043	19.4	2747949	34.0	45435424	89	5584059449
2.60	118.814	8.7	49842	19.6	2892547	34.5	48875980	90	5904900000
2.70	143.489	8.8	52773	19.8	3043168	35.0	52521875	91	6240321451
2.80	172.104	8.9	55841	20.0	3200000	35.5	56382167	92	6590815232
2.90	205.111	9.0	59049	20.2	3363232	36.0	60466176	93	6956883693
3.00	243.000	9.1	62403	20.4	3533059	36.5	64783487	94	7339040224
3.10	286.292	9.2	65908	20.6	3709677	37.0	69343957	95	7737809375
3.20	335.544	9.3	69569	20.8	3893289	37.5	74157715	96	8153726976
3.30	391.354	9.4	73390	21.0	4084101	38.0	79235168	97	8587340257
3.40	454.354	9.5	77378	21.2	4282322	38.5	84587005	98	9039207968
3.50	525.219	9.6	81537	21.4	4488166	39.0	90224199	99	9509900499
3.60	604.662	9.7	85873	21.6	4701850	39.5	96158012		



**SQUARE ROOTS OF FIFTH POWERS OF PIPE SIZES**

(For use in calculations of flow of water, steam, air and gas.)

Standard Sizes of Lap-Welded Pipe.			Even Size Pipe						
Nominal Size, In.	Internal Diameter, d, In.	$\sqrt{d^5}$	Log $\sqrt{d^5}$	Actual Internal Diam., In.	$\sqrt{d^5}$	log $\sqrt{d^5}$	Actual Size Ft. In.	$\sqrt{d^5}$	Log $\sqrt{d^5}$
1/8	0.269	0.037530	2.574380	1/4	0.031250	2.494850	3 6	11432.0	4.058123
1/4	0.364	0.079938	2.902753	1/2	0.176777	1.247425	3 9	13584.2	4.133033
3/8	0.493	0.170651	1.232118	3/4	0.487139	1.687653	4 4	15962.6	4.203103
1/2	0.622	0.305123	1.484475	1	1.000000	0.000000	4 6	21428.2	4.330985
3/4	0.824	0.616337	1.789818	2	5.65686	0.752575	5 5	27885.4	4.445378
1	1.049	1.12704	0.051938	3	15.5885	1.192803	5 6	35388.3	4.548860
1 1/4	1.380	2.23716	0.349698	4	32.0000	1.505150	6 6	43987.6	4.643330
1 1/2	1.610	3.28901	0.517065	5	55.8760	1.747225	6 6	53732.6	4.730238
2	2.067	6.14256	0.788350	6	88.1816	1.945378	7 6	64669.3	4.810698
2 1/2	2.469	8.53696	0.931303	7	129.642	2.112745	7 6	76843.7	4.885608
3	3.068	16.4869	1.217138	8	181.019	2.257725	8 6	90297.9	4.955678
3 1/2	3.548	23.7115	1.374960	9	243.000	2.385608	8 6	105075.	5.021500
4	4.026	32.5226	1.512185	10	316.228	2.500400	9 6	121216.	5.083560
4 1/2	4.506	43.1001	1.634478	11	401.313	2.603483	9 6	138760.	5.142263
5	5.047	57.2246	1.757583	12	498.831	2.697953	10 6	157741.	5.197953
6	6.065	90.5896	1.957078	13	609.338	2.784858	10 6	178208.	5.250928
7	7.023	130.710	2.116308	14	733.364	2.865320	11 6	200187.	5.301435
8	7.981	179.946	2.255143	15	871.420	2.940228	11 6	223717.	5.349698
9	8.941	239.037	2.378465	16	1024.00	3.010300	12 6	248830.	5.395902
10	10.020	317.848	2.502220	18	1374.62	3.138183	12 6	275567.	5.440228
11	11.000	401.313	2.603483	20	1788.86	3.252575	13 6	303957.	5.482813
12	12.000	498.831	2.697953	22	2270.17	3.356058	13 6	334032.	5.523788
13	13.250	639.057	2.805540	24	2821.81	3.450528	14 6	365825.	5.563273
14	14.250	766.546	2.884538	26	3446.94	3.537433	15 6	434693.	5.638183
15	15.250	908.187	2.958175	28	4148.54	3.617895	16 6	510823	5.708253
17 O. D.	16.214	1058.58	3.024725	30	4929.50	3.692803	17 6	594395.	5.774075
18 O. D.	17.182	1223.73	3.087685	32	5792.61	3.762875	18 6	685702.	5.836135
20 O. D.	19.182	1611.52	3.207235	34	6740.59	3.828698	19 6	784943.	5.894838
				36	7776.04	3.890758	20 6	892335.	5.950528
				38	8901.43	3.949460	21 6	1008098.	6.003503
				40	10119.3	4.005150			



CIRCUMFERENCES AND AREAS OF CIRCLES.

Diam.	Circum.	Area.	Diam.	Circum.	Area.	Diam.	Circum.	Area.
1/64	.04909	.00019	2 3/8	7.4613	4.4301	6 1/8	19.242	29.465
1/32	.09818	.00077	7/16	7.6576	4.6664	1/4	19.635	30.680
3/64	.14726	.00173	1/2	7.8540	4.9087	3/8	20.028	31.919
1/16	.19635	.00307	9/16	8.0503	5.1572	1/2	20.420	33.183
3/32	.29452	.00690	5/8	8.2467	5.4119	5/8	20.813	34.472
1/8	.39270	.01227	11/16	8.4430	5.6727	3/4	21.206	35.785
5/32	.49087	.01917	3/4	8.6394	5.9396	7/8	21.598	37.122
3/16	.58905	.02761	13/16	8.8357	6.2126	7.	21.991	38.485
7/32	.68722	.03758	7/8	9.0321	6.4918	1/8	22.384	39.871
			15/16	9.2284	6.7771	1/4	22.776	41.282
1/4	.78540	.04909				3/8	23.169	42.718
9/32	.88357	.06213	3.	9.4248	7.0686	1/2	23.562	44.179
5/16	.98175	.07670	1/16	9.6211	7.3662	5/8	23.955	45.664
11/32	1.0799	.09281	1/8	9.8175	7.6699	3/4	24.347	47.173
3/8	1.1781	.11045	3/16	10.014	7.9798	7/8	24.740	48.707
13/32	1.2763	.12962	1/4	10.210	8.2958	8.	25.133	50.265
7/16	1.3744	.15033	5/16	10.407	8.6179	1/8	25.525	51.849
15/32	1.4726	.17257	3/8	10.603	8.9462	1/4	25.918	53.456
			7/16	10.799	9.2806	3/8	26.311	55.088
1/2	1.5708	.19635	1/2	10.996	9.6211	1/2	26.704	56.745
17/32	1.6690	.22166	9/16	11.192	9.9678	5/8	27.096	58.426
9/16	1.7671	.24850	5/8	11.388	10.321	3/4	27.489	60.132
19/32	1.8653	.27688	11/16	11.585	10.680	7/8	27.882	61.862
5/8	1.9635	.30680	3/4	11.781	11.045	9.	28.274	63.617
21/32	2.0617	.33824	13/16	11.977	11.416	1/8	28.667	65.397
11/16	2.1598	.37122	7/8	12.174	11.793	1/4	29.060	67.201
23/32	2.2580	.40574	15/16	12.370	12.177	3/8	29.452	69.029
			4.	12.566	12.566	1/2	29.845	70.882
3/4	2.3562	.44179	1/16	12.763	12.962	5/8	30.238	72.760
25/32	2.4544	.47937	1/8	12.959	13.364	3/4	30.631	74.662
13/16	2.5525	.51849	3/16	13.155	13.772	7/8	31.023	76.589
27/32	2.6507	.55914	1/4	13.352	14.186	10.	31.416	78.540
7/8	2.7489	.60132	5/16	13.548	14.607	1/8	31.809	80.516
29/32	2.8471	.64504	3/8	13.744	15.033	1/4	32.201	82.516
15/16	2.9452	.69029	7/16	13.941	15.466	3/8	32.594	84.541
31/32	3.0434	.73708	1/2	14.137	15.904	1/2	32.987	86.590
			9/16	14.334	16.349	5/8	33.379	88.664
1.	3.1416	.7854	5/8	14.530	16.800	3/4	33.772	90.763
1/16	3.3379	.8866	11/16	14.726	17.257	7/8	34.165	92.886
1/8	3.5343	.9940	3/4	14.923	17.721	11.	34.558	95.033
3/16	3.7306	1.1075	13/16	15.119	18.190	1/8	34.950	97.205
1/4	3.9270	1.2272	7/8	15.315	18.665	1/4	35.343	99.402
5/16	4.1233	1.3530	15/16	15.512	19.147	3/8	35.736	101.62
3/8	4.3197	1.4849	5.	15.708	19.635	1/2	36.128	103.87
7/16	4.5160	1.6230	1/16	15.904	20.129	5/8	36.521	106.14
1/2	4.7124	1.7671	1/8	16.101	20.629	3/4	36.914	108.43
9/16	4.9087	1.9175	3/16	16.297	21.135	7/8	37.306	110.75
5/8	5.1051	2.0739	1/4	16.493	21.648	12.	37.699	113.10
11/16	5.3014	2.2365	5/16	16.690	22.166	1/8	38.092	115.47
3/4	5.4978	2.4053	3/8	16.886	22.691	1/4	38.485	117.86
13/16	5.6941	2.5802	7/16	17.082	23.221	3/8	38.877	120.28
7/8	5.8905	2.7612	1/2	17.279	23.758	1/2	39.270	122.72
15/16	6.0868	2.9483	9/16	17.475	24.301	5/8	39.663	125.19
			5/8	17.671	24.850	3/4	40.055	127.68
2.	6.2832	3.1416	11/16	17.868	25.406	7/8	40.448	130.19
1/16	6.4795	3.3410	3/4	18.064	25.967	13.	40.841	132.73
1/8	6.6759	3.5466	13/16	18.261	26.535	1/8	41.233	135.30
3/16	6.8722	3.7583	7/8	18.457	27.109	1/4	41.626	137.89
1/4	7.0686	3.9761	15/16	18.653	27.688	3/8	42.019	140.50
5/16	7.2649	4.2000	6.	18.850	28.274	1/2	42.412	143.14

Diam.	Circum.	Area.	Diam.	Circum.	Area.	Diam.	Circum.	Area.
13 <sup>5/8</sup>	42.804	145.80	21 <sup>7/8</sup>	68.722	375.83	30 <sup>1/8</sup>	94.640	712.76
3/4	43.197	148.49	22.	69.115	380.13	1/4	95.033	718.69
7/8	43.590	151.20	1/8	69.508	384.46	3/8	95.426	724.64
14.	43.982	153.94	1/4	69.900	388.82	1/2	95.819	730.62
1/8	44.375	156.70	3/8	70.293	393.20	5/8	96.211	736.62
1/4	44.768	159.48	1/2	70.686	397.61	3/4	96.604	742.64
3/8	45.160	162.30	5/8	71.079	402.04	7/8	96.997	748.69
1/2	45.553	165.13	3/4	71.471	406.49	31.	97.389	754.77
5/8	45.946	167.99	7/8	71.864	410.97	1/8	97.782	760.87
3/4	46.338	170.87	23.	72.257	415.48	1/4	98.175	766.99
7/8	46.731	173.78	1/8	72.649	420.00	3/8	98.567	773.14
15.	47.124	176.71	1/4	73.042	424.56	1/2	98.960	779.31
1/8	47.517	179.67	3/8	73.435	429.13	5/8	99.353	785.51
1/4	47.909	182.65	1/2	73.827	433.74	3/4	99.746	791.73
3/8	48.302	185.66	5/8	74.220	438.36	7/8	100.138	797.98
1/2	48.695	188.69	3/4	74.613	443.01	32.	100.531	804.25
5/8	49.087	191.75	7/8	75.006	447.69	1/8	100.924	810.54
3/4	49.480	194.83	24.	75.398	452.39	1/4	101.316	816.86
7/8	49.873	197.93	1/8	75.791	457.11	3/8	101.709	823.21
16.	50.265	201.06	1/4	76.184	461.86	1/2	102.102	829.58
1/8	50.658	204.22	3/8	76.576	466.64	5/8	102.494	835.97
1/4	51.051	207.39	1/2	76.969	471.44	3/4	102.887	842.39
3/8	51.444	210.60	5/8	77.362	476.26	7/8	103.280	848.83
1/2	51.836	213.82	3/4	77.754	481.11	33.	103.673	855.30
5/8	52.229	217.08	7/8	78.147	485.98	1/8	104.065	861.79
3/4	52.622	220.35	25.	78.540	490.87	1/4	104.458	868.31
7/8	53.014	223.65	1/8	78.933	495.79	3/8	104.851	874.85
17.	53.407	226.98	1/4	79.325	500.74	1/2	105.243	881.41
1/8	53.800	230.33	3/8	79.718	505.71	5/8	105.636	888.00
1/4	54.192	233.71	1/2	80.111	510.71	3/4	106.029	894.62
3/8	54.585	237.10	5/8	80.503	515.72	7/8	106.421	901.26
1/2	54.978	240.53	3/4	80.896	520.77	34.	106.814	907.92
5/8	55.371	243.98	7/8	81.289	525.84	1/8	107.207	914.61
3/4	55.763	247.45	26.	81.681	530.93	1/4	107.600	921.32
7/8	56.156	250.95	1/8	82.074	536.05	3/8	107.992	928.06
18.	56.549	254.47	1/4	82.467	541.19	1/2	108.385	934.82
1/8	56.941	258.02	3/8	82.860	546.35	5/8	108.778	941.61
1/4	57.334	261.59	1/2	83.252	551.55	3/4	109.170	948.42
3/8	57.727	265.18	5/8	83.645	556.76	7/8	109.563	955.25
1/2	58.119	268.80	3/4	84.038	562.00	35.	109.956	962.11
5/8	58.512	272.45	7/8	84.430	567.27	1/8	110.348	969.00
3/4	58.905	276.12	27.	84.823	572.56	1/4	110.741	975.91
7/8	59.298	279.81	1/8	85.216	577.87	3/8	111.134	982.84
19.	59.690	283.53	1/4	85.608	583.21	1/2	111.527	989.80
1/8	60.083	287.27	3/8	86.001	588.57	5/8	111.919	996.78
1/4	60.476	291.04	1/2	86.394	593.96	3/4	112.312	1003.8
3/8	60.868	294.83	5/8	86.786	599.37	7/8	112.705	1010.8
1/2	61.261	298.65	3/4	87.179	604.81	36.	113.097	1017.9
5/8	61.654	302.49	7/8	87.572	610.27	1/8	113.490	1025.0
3/4	62.046	306.35	28.	87.965	615.75	1/4	113.883	1032.1
7/8	62.439	310.24	1/8	88.357	621.26	3/8	114.275	1039.2
20.	62.832	314.16	1/4	88.750	626.80	1/2	114.668	1046.3
1/8	63.225	318.10	3/8	89.143	632.36	5/8	115.061	1053.5
1/4	63.617	322.06	1/2	89.535	637.94	3/4	115.454	1060.7
3/8	64.010	326.05	5/8	89.928	643.55	7/8	115.846	1068.0
1/2	64.403	330.06	3/4	90.321	649.18	37.	116.239	1075.2
5/8	64.795	334.10	7/8	90.713	654.84	1/8	116.632	1082.5
3/4	65.188	338.16	29.	91.106	660.52	1/4	117.024	1089.8
7/8	65.581	342.25	1/8	91.499	666.23	3/8	117.417	1097.1
21.	65.973	346.36	1/4	91.892	671.96	1/2	117.810	1104.5
1/8	66.366	350.50	3/8	92.284	677.71	5/8	118.202	1111.8
1/4	66.759	354.66	1/2	92.677	683.49	3/4	118.596	1119.2
3/8	67.152	358.84	5/8	93.070	689.30	7/8	118.988	1126.7
1/2	67.544	363.05	3/4	93.462	695.13	38.	119.381	1134.1
5/8	67.937	367.28	7/8	93.855	700.98	1/8	119.773	1141.6
3/4	68.330	371.54	30.	94.248	706.86	1/4	120.166	1149.1

Diam.	Circum.	Area.	Diam.	Circum.	Area.	Diam.	Circum.	Area.
38 <sup>3</sup> / <sub>8</sub>	120.559	1156.6	46 <sup>5</sup> / <sub>8</sub>	146.477	1707.4	54 <sup>7</sup> / <sub>8</sub>	172.395	2365.0
1/2	120.951	1164.2	3/4	146.869	1716.5	55.	172.788	2375.8
5/8	121.344	1171.7	7/8	147.262	1725.7	1/8	173.180	2386.6
3/4	121.737	1179.3	47.	147.655	1734.9	1/4	173.573	2397.5
7/8	122.129	1186.9	1/8	148.048	1744.2	3/8	173.966	2408.3
39.	122.522	1194.6	1/4	148.440	1753.5	1/2	174.358	2419.2
1/8	122.915	1202.3	3/8	148.833	1762.7	5/8	174.751	2430.1
1/4	123.308	1210.0	1/2	149.226	1772.1	3/4	175.144	2441.1
3/8	123.700	1217.7	5/8	149.618	1781.4	7/8	175.536	2452.0
1/2	124.093	1225.4	3/4	150.011	1790.8	56.	175.929	2463.0
5/8	124.486	1233.2	7/8	150.404	1800.1	1/8	176.322	2474.0
3/4	124.878	1241.0	48.	150.796	1809.6	1/4	176.715	2485.0
7/8	125.271	1248.8	1/8	151.189	1819.0	3/8	177.107	2496.1
40.	125.664	1256.6	1/4	151.582	1828.5	1/2	177.500	2507.2
1/8	126.056	1264.5	3/8	151.975	1837.9	5/8	177.893	2518.3
1/4	126.449	1272.4	1/2	152.367	1847.5	3/4	178.285	2529.4
3/8	126.842	1280.3	5/8	152.760	1857.0	7/8	178.678	2540.6
1/2	127.235	1288.2	3/4	153.153	1866.5	57.	179.071	2551.8
5/8	127.627	1296.2	7/8	153.545	1876.1	1/8	179.463	2563.0
3/4	128.020	1304.2	49.	153.938	1885.7	1/4	179.856	2574.2
7/8	128.413	1312.2	1/8	154.331	1895.4	3/8	180.249	2585.4
41.	128.805	1320.3	1/4	154.723	1905.0	1/2	180.642	2596.7
1/8	129.198	1328.3	3/8	155.116	1914.7	5/8	181.034	2608.0
1/4	129.591	1336.4	1/2	155.509	1924.4	3/4	181.427	2619.4
3/8	129.983	1344.5	5/8	155.902	1934.2	7/8	181.820	2630.7
1/2	130.376	1352.7	3/4	156.294	1943.9	58.	182.212	2642.1
5/8	130.769	1360.8	7/8	156.687	1953.7	1/8	182.605	2653.5
3/4	131.161	1369.0	50.	157.080	1963.5	1/4	182.998	2664.9
7/8	131.554	1377.2	1/8	157.472	1973.3	3/8	183.390	2676.4
42.	131.947	1385.4	1/4	157.865	1983.2	1/2	183.783	2687.8
1/8	132.340	1393.7	3/8	158.258	1993.1	5/8	184.176	2699.3
1/4	132.732	1402.0	1/2	158.650	2003.0	3/4	184.569	2710.9
3/8	133.125	1410.3	5/8	159.043	2012.9	7/8	184.961	2722.4
1/2	133.518	1418.6	3/4	159.436	2022.8	59.	185.354	2734.0
5/8	133.910	1427.0	7/8	159.829	2032.8	1/8	185.747	2745.6
3/4	134.303	1435.4	51.	160.221	2042.8	1/4	186.139	2757.2
7/8	134.696	1443.8	1/8	160.614	2052.8	3/8	186.532	2768.8
43.	135.088	1452.2	1/4	161.007	2062.9	1/2	186.925	2780.5
1/8	135.481	1460.7	3/8	161.399	2073.0	5/8	187.317	2792.2
1/4	135.874	1469.1	1/2	161.792	2083.1	3/4	187.710	2803.9
3/8	136.267	1477.6	5/8	162.185	2093.2	7/8	188.103	2815.7
1/2	136.659	1486.2	3/4	162.577	2103.3	60.	188.496	2827.4
5/8	137.052	1494.7	7/8	162.970	2113.5	1/8	188.888	2839.2
3/4	137.445	1503.3	52.	163.363	2123.7	1/4	189.281	2851.0
7/8	137.837	1511.9	1/8	163.756	2133.9	3/8	189.674	2862.9
44.	138.230	1520.5	1/4	164.148	2144.2	1/2	190.066	2874.8
1/8	138.623	1529.2	3/8	164.541	2154.5	5/8	190.459	2886.6
1/4	139.015	1537.9	1/2	164.934	2164.8	3/4	190.852	2898.6
3/8	139.408	1546.6	5/8	165.326	2175.1	7/8	191.244	2910.5
1/2	139.801	1555.3	3/4	165.719	2185.4	61.	191.637	2922.5
5/8	140.194	1564.0	7/8	166.112	2195.8	1/8	192.030	2934.5
3/4	140.586	1572.8	53.	166.504	2206.2	1/4	192.423	2946.5
7/8	140.979	1581.6	1/8	166.897	2216.6	3/8	192.815	2958.5
45.	141.372	1590.4	1/4	167.290	2227.0	1/2	193.208	2970.6
1/8	141.764	1599.3	3/8	167.683	2237.5	5/8	193.601	2982.7
1/4	142.157	1608.2	1/2	168.075	2248.0	3/4	193.993	2994.8
3/8	142.550	1617.0	5/8	168.468	2258.5	7/8	194.386	3006.9
1/2	142.942	1626.0	3/4	168.861	2269.1	62.	194.779	3019.1
5/8	143.335	1634.9	7/8	169.253	2279.6	1/8	195.171	3031.3
3/4	143.728	1643.9	54.	169.646	2290.2	1/4	195.564	3043.5
7/8	144.121	1652.9	1/8	170.039	2300.8	3/8	195.957	3055.7
46.	144.513	1661.9	1/4	170.431	2311.5	1/2	196.350	3068.0
1/8	144.906	1670.9	3/8	170.824	2322.1	5/8	196.742	3080.3
1/4	145.299	1680.0	1/2	171.217	2332.8	3/4	197.135	3092.6
3/8	145.691	1689.1	5/8	171.609	2343.5	7/8	197.528	3104.9
1/2	146.084	1698.2	3/4	172.002	2354.3	63.	197.920	3117.2



Diam.	Circum.	Area.	Diam.	Circum.	Area.	Diam.	Circum.	Area.
63 $\frac{1}{8}$	198.313	3129.6	71 $\frac{3}{8}$	224.231	4001.1	79 $\frac{5}{8}$	250.149	4979.5
$\frac{1}{4}$	198.706	3142.0	$\frac{1}{2}$	224.624	4015.2	$\frac{3}{4}$	250.542	4995.2
$\frac{3}{8}$	199.098	3154.5	$\frac{5}{8}$	225.017	4029.2	$\frac{7}{8}$	250.935	5010.9
$\frac{1}{2}$	199.491	3166.9	$\frac{3}{4}$	225.409	4043.3	80.	251.327	5026.5
$\frac{5}{8}$	199.884	3179.4	$\frac{7}{8}$	225.802	4057.4	$\frac{1}{8}$	251.720	5042.3
$\frac{3}{4}$	200.277	3191.9	72.	226.195	4071.5	$\frac{1}{4}$	252.113	5058.0
$\frac{7}{8}$	200.669	3204.4	$\frac{1}{8}$	226.587	4085.7	$\frac{3}{8}$	252.506	5073.8
64.	201.062	3217.0	$\frac{1}{4}$	226.980	4099.8	$\frac{1}{2}$	252.898	5089.6
$\frac{1}{8}$	201.455	3229.6	$\frac{3}{8}$	227.373	4114.0	$\frac{5}{8}$	253.291	5105.4
$\frac{1}{4}$	201.847	3242.2	$\frac{1}{2}$	227.765	4128.2	$\frac{3}{4}$	253.684	5121.2
$\frac{3}{8}$	202.240	3254.8	$\frac{5}{8}$	228.158	4142.5	$\frac{7}{8}$	254.076	5137.1
$\frac{1}{2}$	202.633	3267.5	$\frac{3}{4}$	228.551	4156.8	81.	254.469	5153.0
$\frac{5}{8}$	203.025	3280.1	$\frac{7}{8}$	228.944	4171.1	$\frac{1}{8}$	254.862	5168.9
$\frac{3}{4}$	203.418	3292.8	73.	229.336	4185.4	$\frac{1}{4}$	255.254	5184.9
$\frac{7}{8}$	203.811	3305.6	$\frac{1}{8}$	229.729	4199.7	$\frac{3}{8}$	255.647	5200.8
65.	204.204	3318.3	$\frac{1}{4}$	230.122	4214.1	$\frac{1}{2}$	256.040	5216.8
$\frac{1}{8}$	204.596	3331.1	$\frac{3}{8}$	230.514	4228.5	$\frac{5}{8}$	256.433	5232.8
$\frac{1}{4}$	204.989	3343.9	$\frac{1}{2}$	230.907	4242.9	$\frac{3}{4}$	256.825	5248.9
$\frac{3}{8}$	205.382	3356.7	$\frac{5}{8}$	231.300	4257.4	$\frac{7}{8}$	257.218	5264.9
$\frac{1}{2}$	205.774	3369.6	$\frac{3}{4}$	231.692	4271.8	82.	257.611	5281.0
$\frac{5}{8}$	206.167	3382.4	$\frac{7}{8}$	232.085	4286.3	$\frac{1}{8}$	258.003	5297.1
$\frac{3}{4}$	206.560	3395.3	74.	232.478	4300.8	$\frac{1}{4}$	258.396	5313.3
$\frac{7}{8}$	206.952	3408.2	$\frac{1}{8}$	232.871	4315.4	$\frac{3}{8}$	258.789	5329.4
66.	207.345	3421.2	$\frac{1}{4}$	233.263	4329.9	$\frac{1}{2}$	259.181	5345.6
$\frac{1}{8}$	207.738	3434.2	$\frac{3}{8}$	233.656	4344.5	$\frac{5}{8}$	259.574	5361.8
$\frac{1}{4}$	208.131	3447.2	$\frac{1}{2}$	234.049	4359.2	$\frac{3}{4}$	259.967	5378.1
$\frac{3}{8}$	208.523	3460.2	$\frac{5}{8}$	234.441	4373.8	$\frac{7}{8}$	260.359	5394.3
$\frac{1}{2}$	208.916	3473.2	$\frac{3}{4}$	234.834	4388.5	83.	260.752	5410.6
$\frac{5}{8}$	209.309	3486.3	$\frac{7}{8}$	235.227	4403.1	$\frac{1}{8}$	261.145	5426.9
$\frac{3}{4}$	209.701	3499.4	75.	235.619	4417.9	$\frac{1}{4}$	261.538	5443.3
$\frac{7}{8}$	210.094	3512.5	$\frac{1}{8}$	236.012	4432.6	$\frac{3}{8}$	261.930	5459.6
67.	210.487	3525.7	$\frac{1}{4}$	236.405	4447.4	$\frac{1}{2}$	262.323	5476.0
$\frac{1}{8}$	210.879	3538.8	$\frac{3}{8}$	236.798	4462.2	$\frac{5}{8}$	262.716	5492.4
$\frac{1}{4}$	211.272	3552.0	$\frac{1}{2}$	237.190	4477.0	$\frac{3}{4}$	263.108	5508.8
$\frac{3}{8}$	211.665	3565.2	$\frac{5}{8}$	237.583	4491.8	$\frac{7}{8}$	263.501	5525.3
$\frac{1}{2}$	212.058	3578.5	$\frac{3}{4}$	237.976	4506.7	84.	263.894	5541.8
$\frac{5}{8}$	212.450	3591.7	$\frac{7}{8}$	238.368	4521.5	$\frac{1}{8}$	264.286	5558.3
$\frac{3}{4}$	212.843	3605.0	76.	238.761	4536.5	$\frac{1}{4}$	264.679	5574.8
$\frac{7}{8}$	213.236	3618.3	$\frac{1}{8}$	239.154	4551.4	$\frac{3}{8}$	265.072	5591.4
68.	213.628	3631.7	$\frac{1}{4}$	239.546	4566.4	$\frac{1}{2}$	265.465	5607.9
$\frac{1}{8}$	214.021	3645.0	$\frac{3}{8}$	239.939	4581.3	$\frac{5}{8}$	265.857	5624.5
$\frac{1}{4}$	214.414	3658.4	$\frac{1}{2}$	240.332	4596.3	$\frac{3}{4}$	266.250	5641.2
$\frac{3}{8}$	214.806	3671.8	$\frac{5}{8}$	240.725	4611.4	$\frac{7}{8}$	266.643	5657.8
$\frac{1}{2}$	215.199	3685.3	$\frac{3}{4}$	241.117	4626.4	85.	267.035	5674.5
$\frac{5}{8}$	215.592	3698.7	$\frac{7}{8}$	241.510	4641.5	$\frac{1}{8}$	267.428	5691.2
$\frac{3}{4}$	215.984	3712.2	77.	241.903	4656.6	$\frac{1}{4}$	267.821	5707.9
$\frac{7}{8}$	216.377	3725.7	$\frac{1}{8}$	242.295	4671.8	$\frac{3}{8}$	268.213	5724.7
69.	216.770	3739.3	$\frac{1}{4}$	242.688	4686.9	$\frac{1}{2}$	268.606	5741.5
$\frac{1}{8}$	217.163	3752.8	$\frac{3}{8}$	243.081	4702.1	$\frac{5}{8}$	268.999	5758.3
$\frac{1}{4}$	217.555	3766.4	$\frac{1}{2}$	243.473	4717.3	$\frac{3}{4}$	269.392	5775.1
$\frac{3}{8}$	217.948	3780.0	$\frac{5}{8}$	243.866	4732.5	$\frac{7}{8}$	269.784	5791.9
$\frac{1}{2}$	218.341	3793.7	$\frac{3}{4}$	244.259	4747.8	86.	270.177	5808.8
$\frac{5}{8}$	218.733	3807.3	$\frac{7}{8}$	244.652	4763.1	$\frac{1}{8}$	270.570	5825.7
$\frac{3}{4}$	219.126	3821.0	78.	245.044	4778.4	$\frac{1}{4}$	270.962	5842.6
$\frac{7}{8}$	219.519	3834.7	$\frac{1}{8}$	245.437	4793.7	$\frac{3}{8}$	271.355	5859.6
70.	219.911	3848.5	$\frac{1}{4}$	245.830	4809.0	$\frac{1}{2}$	271.748	5876.5
$\frac{1}{8}$	220.304	3862.2	$\frac{3}{8}$	246.222	4824.4	$\frac{5}{8}$	272.140	5893.5
$\frac{1}{4}$	220.697	3876.0	$\frac{1}{2}$	246.615	4839.8	$\frac{3}{4}$	272.533	5910.6
$\frac{3}{8}$	221.090	3889.8	$\frac{5}{8}$	247.008	4855.2	$\frac{7}{8}$	272.926	5927.6
$\frac{1}{2}$	221.482	3903.6	$\frac{3}{4}$	247.400	4870.7	87.	273.319	5944.7
$\frac{5}{8}$	221.875	3917.5	$\frac{7}{8}$	247.793	4886.2	$\frac{1}{8}$	273.711	5961.8
$\frac{3}{4}$	222.268	3931.4	79.	248.186	4901.7	$\frac{1}{4}$	274.104	5978.9
$\frac{7}{8}$	222.660	3945.3	$\frac{1}{8}$	248.579	4917.2	$\frac{3}{8}$	274.497	5996.0
71.	223.053	3959.2	$\frac{1}{4}$	248.971	4932.7	$\frac{1}{2}$	274.889	6013.2
$\frac{1}{8}$	223.446	3973.1	$\frac{3}{8}$	249.364	4948.3	$\frac{5}{8}$	275.282	6030.4
$\frac{1}{4}$	223.838	3987.1	$\frac{1}{2}$	249.757	4963.9	$\frac{3}{4}$	275.675	6047.6



Diam.	Circum.	Area.	Diam.	Circum.	Area.	Diam.	Circum.	Area.
<b>87</b> 7/8	276.067	6064.9	<b>95</b> 7/8	301.200	7219.4	<b>130</b>	408.41	13273.23
<b>88.</b>	276.460	6082.1	<b>96.</b>	301.593	7238.2	<b>131</b>	411.55	13478.22
1/8	276.853	6099.4	1/8	301.986	7257.1	<b>132</b>	414.69	13684.78
1/4	277.246	6116.7	1/4	302.378	7276.0	<b>133</b>	417.83	13892.91
3/8	277.638	6134.1	3/8	302.771	7294.9	<b>134</b>	420.97	14102.61
1/2	278.031	6151.4	1/2	303.164	7313.8	<b>135</b>	424.12	14313.88
5/8	278.424	6168.8	5/8	303.556	7332.8	<b>136</b>	427.26	14526.72
3/4	278.816	6186.2	3/4	303.949	7351.8	<b>137</b>	430.40	14741.14
7/8	279.209	6203.7	7/8	304.342	7370.8	<b>138</b>	433.54	14957.12
<b>89.</b>	279.602	6221.1	<b>97.</b>	304.734	7389.8	<b>139</b>	436.68	15174.68
1/8	279.994	6238.6	1/8	305.127	7408.9	<b>140</b>	439.82	15393.80
1/4	280.387	6256.1	1/4	305.520	7428.0	<b>141</b>	442.96	15614.50
3/8	280.780	6273.7	3/8	305.913	7447.1	<b>142</b>	446.11	15836.77
1/2	281.173	6291.2	1/2	306.305	7466.2	<b>143</b>	449.25	16060.61
5/8	281.565	6308.8	5/8	306.698	7485.3	<b>144</b>	452.39	16286.02
3/4	281.958	6326.4	3/4	307.091	7504.5	<b>145</b>	455.53	16513.00
7/8	282.351	6344.1	7/8	307.483	7523.7	<b>146</b>	458.67	16741.55
<b>90.</b>	282.743	6361.7	<b>98.</b>	307.876	7543.0	<b>147</b>	461.81	16971.67
1/8	283.136	6379.4	1/8	308.269	7562.2	<b>148</b>	464.96	17203.36
1/4	283.529	6397.1	1/4	308.661	7581.5	<b>149</b>	468.10	17436.62
3/8	283.921	6414.9	3/8	309.054	7600.8	<b>150</b>	471.24	17671.46
1/2	284.314	6432.6	1/2	309.447	7620.1	<b>151</b>	474.38	17907.86
5/8	284.707	6450.4	5/8	309.840	7639.5	<b>152</b>	477.52	18145.84
3/4	285.100	6468.2	3/4	310.232	7658.9	<b>153</b>	480.66	18385.39
7/8	285.492	6486.0	7/8	310.625	7678.3	<b>154</b>	483.81	18626.50
<b>91.</b>	285.885	6503.9	<b>99.</b>	311.018	7697.7	<b>155</b>	486.95	18869.19
1/8	286.278	6521.8	1/8	311.410	7717.1	<b>156</b>	490.09	19113.45
1/4	286.670	6539.7	1/4	311.803	7736.6	<b>157</b>	493.23	19359.28
3/8	287.063	6557.6	3/8	312.196	7756.1	<b>158</b>	496.37	19606.68
1/2	287.456	6575.5	1/2	312.588	7775.6	<b>159</b>	499.51	19855.65
5/8	287.848	6593.5	5/8	312.981	7795.2	<b>160</b>	502.65	20106.19
3/4	288.241	6611.5	3/4	313.374	7814.8	<b>161</b>	505.80	20358.31
7/8	288.634	6629.6	7/8	313.767	7834.4	<b>162</b>	508.94	20611.99
<b>92.</b>	289.027	6647.6	<b>100</b>	314.159	7854.0	<b>163</b>	512.08	20867.24
1/8	289.419	6665.7	<b>101</b>	317.30	8011.85	<b>164</b>	515.22	21124.07
1/4	289.812	6683.8	<b>102</b>	320.44	8171.28	<b>165</b>	518.36	21382.46
3/8	290.205	6701.9	<b>103</b>	323.58	8332.29	<b>166</b>	521.50	21642.43
1/2	290.597	6720.1	<b>104</b>	326.73	8494.87	<b>167</b>	524.65	21903.97
5/8	290.990	6738.2	<b>105</b>	329.87	8659.01	<b>168</b>	527.79	22167.08
3/4	291.383	6756.4	<b>106</b>	333.01	8824.73	<b>169</b>	530.93	22431.76
7/8	291.775	6774.7	<b>107</b>	336.15	8992.02	<b>170</b>	534.07	22698.01
<b>93.</b>	292.168	6792.9	<b>108</b>	339.29	9160.88	<b>171</b>	537.21	22965.83
1/8	292.561	6811.2	<b>109</b>	342.43	9331.32	<b>172</b>	540.35	23235.22
1/4	292.954	6829.5	<b>110</b>	345.58	9503.32	<b>173</b>	543.50	23506.18
3/8	293.346	6847.8	<b>111</b>	348.72	9676.89	<b>174</b>	546.64	23778.71
1/2	293.739	6866.1	<b>112</b>	351.86	9852.03	<b>175</b>	549.78	24052.82
5/8	294.132	6884.5	<b>113</b>	355.00	10028.75	<b>176</b>	552.92	24328.49
3/4	294.524	6902.9	<b>114</b>	358.14	10207.03	<b>177</b>	556.06	24605.74
7/8	294.917	6921.3	<b>115</b>	361.28	10386.89	<b>178</b>	559.20	24884.56
<b>94.</b>	295.310	6939.8	<b>116</b>	364.42	10568.32	<b>179</b>	562.35	25164.94
1/8	295.702	6958.2	<b>117</b>	367.57	10751.32	<b>180</b>	565.49	25446.90
1/4	296.095	6976.7	<b>118</b>	370.71	10935.88	<b>181</b>	568.63	25730.43
3/8	296.488	6995.3	<b>119</b>	373.85	11122.02	<b>182</b>	571.77	26015.53
1/2	296.881	7013.8	<b>120</b>	376.99	11309.73	<b>183</b>	574.91	26302.20
5/8	297.273	7032.4	<b>121</b>	380.13	11499.01	<b>184</b>	578.05	26590.44
3/4	297.666	7051.0	<b>122</b>	383.27	11689.87	<b>185</b>	581.19	26880.25
7/8	298.059	7069.6	<b>123</b>	386.42	11882.29	<b>186</b>	584.34	27171.63
<b>95.</b>	298.451	7088.2	<b>124</b>	389.56	12076.28	<b>187</b>	587.48	27464.59
1/8	298.844	7106.9	<b>125</b>	392.70	12271.85	<b>188</b>	590.62	27759.11
1/4	299.237	7125.6	<b>126</b>	395.84	12468.98	<b>189</b>	593.76	28055.21
3/8	299.629	7144.3	<b>127</b>	398.98	12667.69	<b>190</b>	596.90	28352.87
1/2	300.022	7163.0	<b>128</b>	402.12	12867.96	<b>191</b>	600.04	28652.11
5/8	300.415	7181.8	<b>129</b>	405.27	13069.81	<b>192</b>	603.19	28952.92
3/4	300.807	7200.6						

Diam.	Circum.	Area.	Diam.	Circum.	Area.	Diam.	Circum.	Area.
193	606.33	29255.30	<b>260</b>	816.81	53092.92	327	1027.30	83981.84
194	609.47	29559.25	261	819.96	53502.11	328	1030.44	84496.28
195	612.61	29864.77	262	823.10	53912.87	329	1033.58	85012.28
196	615.75	30171.86	263	826.24	54325.21	<b>330</b>	1036.73	85529.86
197	618.89	30480.52	264	829.38	54739.11	331	1039.87	86049.01
198	622.04	30790.75	265	832.52	55154.59	332	1043.01	86569.73
199	625.18	31102.55	266	835.66	55571.63	333	1046.15	87092.02
<b>200</b>	628.32	31415.93	267	838.81	55990.25	334	1049.29	87615.88
201	631.46	31730.87	268	841.95	56410.44	335	1052.43	88141.31
202	634.60	32047.39	269	845.09	56832.20	336	1055.58	88668.31
203	637.74	32365.47	<b>270</b>	848.23	57255.53	337	1058.72	89196.88
204	640.88	32685.13	271	851.37	57680.43	338	1061.86	89727.03
205	644.03	33006.36	272	854.51	58106.90	339	1065.00	90258.74
206	647.17	33329.16	273	857.65	58534.94	<b>340</b>	1068.14	90792.03
207	650.31	33653.53	274	860.80	58964.55	341	1071.28	91326.88
208	653.45	33979.47	275	863.94	59395.74	342	1074.42	91863.31
209	656.59	34306.98	276	867.08	59828.49	343	1077.57	92401.31
<b>210</b>	659.73	34636.06	277	870.22	60262.82	344	1080.71	92940.88
211	662.88	34966.71	278	873.36	60698.71	345	1083.85	93482.02
212	666.02	35298.94	279	876.50	61136.18	346	1086.99	94024.73
213	669.16	35632.73	<b>280</b>	879.65	61575.22	347	1090.13	94569.01
214	672.30	35968.09	281	882.79	62015.82	348	1093.27	95114.86
215	675.44	36305.03	282	885.93	62458.00	349	1096.42	95662.28
216	678.58	36643.54	283	889.07	62901.75	<b>350</b>	1099.56	96211.28
217	681.73	36983.61	284	892.21	63347.07	351	1102.70	96761.84
218	684.87	37325.26	285	895.35	63793.97	352	1105.84	97313.97
219	688.01	37668.48	286	898.50	64242.43	353	1108.98	97867.68
<b>220</b>	691.15	38013.27	287	901.64	64692.46	354	1112.12	98422.96
221	694.29	38359.63	288	904.78	65144.07	355	1115.27	98979.80
222	697.43	38707.56	289	907.92	65597.24	356	1118.41	99538.22
223	700.58	39057.07	<b>290</b>	911.06	66051.99	357	1121.55	100098.21
224	703.72	39408.14	291	914.20	66508.30	358	1124.69	100659.77
225	706.86	39760.78	292	917.35	66966.19	359	1127.83	101222.90
226	710.00	40115.00	293	920.49	67425.65	<b>360</b>	1130.97	101787.60
227	713.14	40470.78	294	923.63	67886.68	361	1134.11	102353.87
228	716.28	40828.14	295	926.77	68349.28	362	1137.26	102921.72
229	719.42	41187.07	296	929.91	68813.45	363	1140.40	103491.13
<b>230</b>	722.57	41547.56	297	933.05	69279.19	364	1143.54	104062.12
231	725.71	41909.63	298	936.19	69746.50	365	1146.68	104634.67
232	728.85	42273.27	299	939.34	70215.38	366	1149.82	105208.80
233	731.99	42638.48	<b>300</b>	942.48	70685.83	367	1152.96	105784.49
234	735.13	43005.26	301	945.62	71157.86	368	1156.11	106361.76
235	738.27	43373.61	302	948.76	71631.45	369	1159.25	106940.60
236	741.42	43743.54	303	951.90	72106.62	<b>370</b>	1162.39	107521.01
237	744.56	44115.03	304	955.04	72583.36	371	1165.53	108102.99
238	747.70	44488.09	305	958.19	73061.66	372	1168.67	108686.54
239	750.84	44862.73	306	961.33	73541.54	373	1171.81	109271.66
<b>240</b>	753.98	45238.93	307	964.47	74022.99	374	1174.96	109858.35
241	757.12	45616.71	308	967.61	74506.01	375	1178.10	110446.62
242	760.27	45996.06	309	970.75	74990.60	376	1181.24	111036.45
243	763.41	46376.98	<b>310</b>	973.89	75476.76	377	1184.33	111627.86
244	766.55	46759.47	311	977.04	75964.50	378	1187.52	112220.83
245	769.69	47143.52	312	980.18	76453.80	379	1190.66	112815.38
246	772.83	47529.16	313	983.32	76944.67	<b>380</b>	1193.81	113411.49
247	775.97	47916.36	314	986.46	77437.12	381	1196.95	114009.18
248	779.11	48305.13	315	989.60	77931.13	382	1200.09	114608.44
249	782.26	48695.47	316	992.74	78426.72	383	1203.23	115209.27
<b>250</b>	785.40	49087.39	317	995.88	78923.88	384	1206.37	115811.67
251	788.54	49480.87	318	999.03	79422.60	385	1209.51	116415.64
252	791.68	49875.92	319	1002.17	79922.90	386	1212.65	117021.18
253	794.82	50272.55	<b>320</b>	1005.31	80424.77	387	1215.80	117628.30
254	797.96	50670.75	321	1008.45	80928.21	388	1218.94	118236.98
255	801.11	51070.52	322	1011.59	81433.22	389	1222.08	118847.24
256	804.25	51471.85	323	1014.73	81939.80	<b>390</b>	1225.22	119459.06
257	807.39	51874.76	324	1017.88	82447.96	391	1228.36	120072.46
258	810.53	52279.24	325	1021.02	82957.68	392	1231.50	120687.46
259	813.67	52685.29	326	1024.16	83468.98	393	1234.65	121303.96



Diam.	Circum.	Area.	Diam.	Circum.	Area.	Diam.	Circum.	Area.
394	1237.79	121922.07	461	1448.27	166913.60	528	1658.76	218956.44
395	1240.93	122541.75	462	1451.42	167638.53	529	1661.90	219786.61
396	1244.07	123163.00	463	1454.56	168365.02	530	1665.04	220618.34
397	1247.21	123785.82	464	1457.70	169093.08	531	1668.19	221451.65
398	1250.35	124410.21	465	1460.84	169822.72	532	1671.33	222286.53
399	1253.50	125036.17	466	1463.98	170553.92	533	1674.47	223122.98
400	1256.64	125663.71	467	1467.12	171286.70	534	1677.61	223961.00
401	1259.78	126292.81	468	1470.27	172021.05	535	1680.75	224800.59
402	1262.92	126923.48	469	1473.41	172756.97	536	1683.89	225641.75
403	1266.06	127555.73	470	1476.55	173494.45	537	1687.04	226484.48
404	1269.20	128189.55	471	1479.69	174233.51	538	1690.18	227328.79
405	1272.35	128824.93	472	1482.83	174974.14	539	1693.32	228174.66
406	1275.49	129461.89	473	1485.97	175716.35	540	1696.46	229022.10
407	1278.63	130100.42	474	1489.11	176460.12	541	1699.60	229871.12
408	1281.77	130740.52	475	1492.26	177205.46	542	1702.74	230721.71
409	1284.91	131382.19	476	1495.40	177952.37	543	1705.88	231573.86
410	1288.05	132025.43	477	1498.54	178700.86	544	1709.03	232427.59
411	1291.19	132670.24	478	1501.68	179450.91	545	1712.17	233282.89
412	1294.34	133316.63	479	1504.82	180202.54	546	1715.31	234139.76
413	1297.48	133964.58	480	1507.96	180955.74	547	1718.45	234998.20
414	1300.62	134614.10	481	1511.11	181710.50	548	1721.59	235858.21
415	1303.76	135265.20	482	1514.25	182466.84	549	1724.73	236719.79
416	1306.90	135917.86	483	1517.39	183224.75	550	1727.88	237582.94
417	1310.04	136572.10	484	1520.53	183984.23	551	1731.02	238447.67
418	1313.19	137227.91	485	1523.67	184745.28	552	1734.16	239313.96
419	1316.33	137885.29	486	1526.81	185507.90	553	1737.30	240181.83
420	1319.47	138544.24	487	1529.96	186272.10	554	1740.44	241051.26
421	1322.61	139204.76	488	1533.10	187037.86	555	1743.58	241922.27
422	1325.75	139866.85	489	1536.24	187805.19	556	1746.73	242794.85
423	1328.89	140530.51	490	1539.38	188574.10	557	1749.87	243668.99
424	1332.04	141195.74	491	1542.52	189344.57	558	1753.01	244544.71
425	1335.18	141862.54	492	1545.66	190116.62	559	1756.15	245422.00
426	1338.32	142530.92	493	1548.81	190890.24	560	1759.29	246300.86
427	1341.46	143200.86	494	1551.95	191665.43	561	1762.43	247181.30
428	1344.60	143872.38	495	1555.09	192442.18	562	1765.58	248063.30
429	1347.74	144545.46	496	1558.23	193220.51	563	1768.72	248946.87
430	1350.88	145220.12	497	1561.37	194000.41	564	1771.86	249832.01
431	1354.03	145896.35	498	1564.51	194781.89	565	1775.00	250718.73
432	1357.17	146574.15	499	1567.65	195564.93	566	1778.14	251607.01
433	1360.31	147253.52	500	1570.80	196349.54	567	1781.28	252496.87
434	1363.45	147934.46	501	1573.94	197135.72	568	1784.42	253388.30
435	1366.59	148616.97	502	1577.08	197923.48	569	1787.57	254281.29
436	1369.73	149301.05	503	1580.22	198712.80	570	1790.71	255175.86
437	1372.88	149986.70	504	1583.36	199503.70	571	1793.85	256072.00
438	1376.02	150673.93	505	1586.50	200296.17	572	1796.99	256969.71
439	1379.16	151362.72	506	1589.65	201090.20	573	1800.13	257868.99
440	1382.30	152053.08	507	1592.79	201885.81	574	1803.27	258769.85
441	1385.44	152745.02	508	1595.93	202682.99	575	1806.42	259672.27
442	1388.58	153438.53	509	1599.07	203481.74	576	1809.56	260576.26
443	1391.73	154133.60	510	1602.21	204282.06	577	1812.70	261481.83
444	1394.87	154830.25	511	1605.35	205083.95	578	1815.84	262388.96
445	1398.01	155528.47	512	1608.50	205887.42	579	1818.98	263297.67
446	1401.15	156228.26	513	1611.64	206692.45	580	1822.12	264207.94
447	1404.29	156929.62	514	1614.78	207499.05	581	1825.27	265119.79
448	1407.43	157632.55	515	1617.92	208307.23	582	1828.41	266033.21
449	1410.58	158337.06	516	1621.06	209116.97	583	1831.55	266948.20
450	1413.72	159043.13	517	1624.20	209928.29	584	1834.69	267864.76
451	1416.86	159750.77	518	1627.34	210741.18	585	1837.83	268782.89
452	1420.00	160459.99	519	1630.49	211555.63	586	1840.97	269702.59
453	1423.14	161170.77	520	1633.63	212371.66	587	1844.11	270623.86
454	1426.28	161883.13	521	1636.77	213189.26	588	1847.26	271546.70
455	1429.42	162597.05	522	1639.91	214008.43	589	1850.40	272471.12
456	1432.57	163312.55	523	1643.05	214829.17	590	1853.54	273397.10
457	1435.71	164029.62	524	1646.19	215651.49	591	1856.68	274324.66
458	1438.85	164748.26	525	1649.34	216475.37	592	1859.82	275253.78
459	1441.99	165468.47	526	1652.48	217300.82	593	1862.96	276184.48
460	1445.13	166190.25	527	1655.62	218127.85	594	1866.11	277116.75

Diam.	Circum.	Area.	Diam.	Circum.	Area.	Diam.	Circum.	Area.
595	1869.25	278050.58	663	2082.88	345236.69	731	2296.50	419686.15
596	1872.39	278985.99	664	2086.02	346278.91	732	2299.65	420835.19
597	1875.53	279922.97	665	2089.16	347322.70	733	2302.79	421985.79
598	1878.67	280861.52	666	2092.30	348368.07	734	2305.93	423137.97
599	1881.81	281801.65	667	2095.44	349415.00	735	2309.07	424291.72
600	1884.96	282743.34	668	2098.58	350463.51	736	2312.21	425447.04
601	1888.10	283686.60	669	2101.73	351513.59	737	2315.35	426603.94
602	1891.24	284631.44	670	2104.87	352565.24	738	2318.50	427762.40
603	1894.38	285577.84	671	2108.01	353618.45	739	2321.64	428922.43
604	1897.52	286525.82	672	2111.15	354673.24	740	2324.78	430084.03
605	1900.66	287475.36	673	2114.29	355729.60	741	2327.92	431247.21
606	1903.81	288426.48	674	2117.43	356787.54	742	2331.06	432411.95
607	1906.95	289379.17	675	2120.58	357847.04	743	2334.20	433578.27
608	1910.09	290333.43	676	2123.72	358908.11	744	2337.34	434746.16
609	1913.23	291289.26	677	2126.86	359970.75	745	2340.49	435915.62
610	1916.37	292246.66	678	2130.00	361034.97	746	2343.63	437086.64
611	1919.51	293205.63	679	2133.14	362100.75	747	2346.77	438259.24
612	1922.65	294166.17	680	2136.28	363168.11	748	2349.91	439433.41
613	1925.80	295128.28	681	2139.42	364237.04	749	2353.05	440609.16
614	1928.94	296091.97	682	2142.57	365307.54	750	2356.19	441786.47
615	1932.08	297057.22	683	2145.71	366379.60	751	2359.34	442965.35
616	1935.22	298024.05	684	2148.85	367453.24	752	2362.48	444145.80
617	1938.36	298992.44	685	2151.99	368528.45	753	2365.62	445327.83
618	1941.50	299962.41	686	2155.13	369605.23	754	2368.76	446511.42
619	1944.65	300933.95	687	2158.27	370683.59	755	2371.90	447696.59
620	1947.79	301907.05	688	2161.42	371763.51	756	2375.04	448883.32
621	1950.93	302881.73	689	2164.56	372845.00	757	2378.19	450071.63
622	1954.07	303857.98	690	2167.70	373928.07	758	2381.33	451261.51
623	1957.21	304835.80	691	2170.84	375012.70	759	2384.47	452452.96
624	1960.35	305815.20	692	2173.98	376098.91	760	2387.61	453645.98
625	1963.50	306796.16	693	2177.12	377186.68	761	2390.75	454840.57
626	1966.64	307778.69	694	2180.27	378276.03	762	2393.89	456036.73
627	1969.78	308762.79	695	2183.41	379366.95	763	2397.04	457234.46
628	1972.92	309748.47	696	2186.55	380459.44	764	2400.18	458433.77
629	1976.06	310735.71	697	2189.69	381553.50	765	2403.32	459634.64
630	1979.20	311724.53	698	2192.83	382649.13	766	2406.46	460837.10
631	1982.35	312714.92	699	2195.97	383746.33	767	2409.60	462041.08
632	1985.49	313706.88	700	2199.11	384845.10	768	2412.74	463246.69
633	1988.63	314700.40	701	2202.26	385945.44	769	2415.88	464453.84
634	1991.77	315695.50	702	2205.40	387047.36	770	2419.03	465662.57
635	1994.91	316692.17	703	2208.54	388150.84	771	2422.17	466872.87
636	1998.05	317690.42	704	2211.68	389255.90	772	2425.31	468084.74
637	2001.19	318690.23	705	2214.82	390362.52	773	2428.45	469298.18
638	2004.34	319691.61	706	2217.96	391470.72	774	2431.59	470513.19
639	2007.48	320694.56	707	2221.11	392580.49	775	2434.73	471729.77
640	2010.62	321699.09	708	2224.25	393691.82	776	2437.88	472947.92
641	2013.76	322705.18	709	2227.39	394804.73	777	2441.02	474167.65
642	2016.90	323712.85	710	2230.53	395919.21	778	2444.16	475388.94
643	2020.04	324722.09	711	2233.67	397035.26	779	2447.30	476611.81
644	2023.19	325732.89	712	2236.81	398152.89	780	2450.44	477836.24
645	2026.33	326745.27	713	2239.96	399272.08	781	2453.58	479062.25
646	2029.47	327759.22	714	2243.10	400392.84	782	2456.73	480289.83
647	2032.61	328774.74	715	2246.24	401515.18	783	2459.87	481518.97
648	2035.75	329791.83	716	2249.38	402639.08	784	2463.01	482749.69
649	2038.89	330810.49	717	2252.52	403764.56	785	2466.15	483981.98
650	2042.04	331830.72	718	2255.66	404891.60	786	2469.29	485215.84
651	2045.18	332852.53	719	2258.81	406020.22	787	2472.43	486451.28
652	2048.32	333875.90	720	2261.95	407150.41	788	2475.58	487688.28
653	2051.46	334900.85	721	2265.09	408282.17	789	2478.72	488926.85
654	2054.60	335927.36	722	2268.23	409415.50	790	2481.86	490166.99
655	2057.74	336955.45	723	2271.37	410550.40	791	2485.00	491408.71
656	2060.88	337985.10	724	2274.51	411686.87	792	2488.14	492651.99
657	2064.03	339016.33	725	2277.65	412824.91	793	2491.28	493896.85
658	2067.17	340049.13	726	2280.80	413964.52	794	2494.42	495143.28
659	2070.31	341083.50	727	2283.94	415105.71	795	2497.57	496391.27
660	2073.45	342119.44	728	2287.08	416248.46	796	2500.71	497640.84
661	2076.59	343156.95	729	2290.22	417392.79	797	2503.85	498891.98
662	2079.73	344196.03	730	2293.36	418538.68	798	2506.99	500144.69



Diam.	Circum.	Area.	Diam.	Circum.	Area.	Diam.	Circum.	Area.
799	2510.13	501398.97	867	2723.76	590375.16	935	2937.39	686614.71
800	2513.27	502654.82	868	2726.90	591737.83	936	2940.53	688084.19
801	2516.42	503912.25	869	2730.04	593102.06	937	2943.67	689555.24
802	2519.56	505171.24	870	2733.19	594467.87	938	2946.81	691027.86
803	2522.70	506431.80	871	2736.33	595835.25	939	2949.96	692502.05
804	2525.84	507693.94	872	2739.47	597204.20	940	2953.10	693977.82
805	2528.98	508957.64	873	2742.61	598574.72	941	2956.24	695455.15
806	2532.12	510222.92	874	2745.75	599946.81	942	2959.38	696934.06
807	2535.27	511489.77	875	2748.89	601320.47	943	2962.52	698414.53
808	2538.41	512758.19	876	2752.04	602695.70	944	2965.66	699896.58
809	2541.55	514028.18	877	2755.18	604072.50	945	2968.81	701380.19
810	2544.69	515299.74	878	2758.32	605450.88	946	2971.95	702865.38
811	2547.83	516572.87	879	2761.46	606830.82	947	2975.09	704352.14
812	2550.97	517847.57	880	2764.60	608212.34	948	2978.23	705840.47
813	2554.11	519123.84	881	2767.74	609595.42	949	2981.37	707330.37
814	2557.26	520401.68	882	2770.88	610980.08	950	2984.51	708821.84
815	2560.40	521681.10	883	2774.03	612366.31	951	2987.65	710314.88
816	2563.54	522962.08	884	2777.17	613754.11	952	2990.80	711809.50
817	2566.68	524244.63	885	2780.31	615143.48	953	2993.94	713305.68
818	2569.82	525528.76	886	2783.45	616534.42	954	2997.08	714803.43
819	2572.96	526814.46	887	2786.59	617926.93	955	3000.22	716302.76
820	2576.11	528101.73	888	2789.73	619321.01	956	3003.36	717803.66
821	2579.25	529390.56	889	2792.88	620716.66	957	3006.50	719306.12
822	2582.39	530680.97	890	2796.02	622113.89	958	3009.65	720810.16
823	2585.53	531972.95	891	2799.16	623512.68	959	3012.79	722315.77
824	2588.67	533266.50	892	2802.30	624913.04	960	3015.93	723822.95
825	2591.81	534561.62	893	2805.44	626314.98	961	3019.07	725331.70
826	2594.96	535858.32	894	2808.58	627718.49	962	3022.21	726842.02
827	2598.10	537156.58	895	2811.73	629123.56	963	3025.35	728353.91
828	2601.24	538456.41	896	2814.87	630530.21	964	3028.50	729867.37
829	2604.38	539757.82	897	2818.01	631938.43	965	3031.64	731382.40
830	2607.52	541060.79	898	2821.15	633348.22	966	3034.78	732899.01
831	2610.66	542365.34	899	2824.29	634759.58	967	3037.92	734417.18
832	2613.81	543671.46	900	2827.43	636172.51	968	3041.06	735936.93
833	2616.95	544979.15	901	2830.58	637587.01	969	3044.20	737458.24
834	2620.09	546288.40	902	2833.72	639003.09	970	3047.34	738981.13
835	2623.23	547599.23	903	2836.86	640420.73	971	3050.49	740505.59
836	2626.37	548911.63	904	2840.00	641839.95	972	3053.63	742031.62
837	2629.51	550225.61	905	2843.14	643260.73	973	3056.77	743559.22
838	2632.65	551541.15	906	2846.28	644683.09	974	3059.91	745088.39
839	2635.80	552858.26	907	2849.42	646107.01	975	3063.05	746619.13
840	2638.94	554176.94	908	2852.57	647532.51	976	3066.19	748151.44
841	2642.08	555497.20	909	2855.71	648959.58	977	3069.34	749685.32
842	2645.22	556819.02	910	2858.85	650388.22	978	3072.48	751220.78
843	2648.36	558142.42	911	2861.99	651818.43	979	3075.62	752757.80
844	2651.50	559467.39	912	2865.13	653250.21	980	3078.76	754296.40
845	2654.65	560793.92	913	2868.27	654683.56	981	3081.90	755836.56
846	2657.79	562122.03	914	2871.42	656118.48	982	3085.04	757378.30
847	2660.93	563451.71	915	2874.56	657554.98	983	3088.19	758921.61
848	2664.07	564782.96	916	2877.70	658993.04	984	3091.33	760466.48
849	2667.21	566115.78	917	2880.84	660432.68	985	3094.47	762012.93
850	2670.35	567450.17	918	2883.98	661873.88	986	3097.61	763560.95
851	2673.50	568786.14	919	2887.12	663316.66	987	3100.75	765110.54
852	2676.64	570123.67	920	2890.27	664761.01	988	3103.89	766661.70
853	2679.78	571462.77	921	2893.41	666206.92	989	3107.04	768214.44
854	2682.92	572803.45	922	2896.55	667654.41	990	3110.18	769768.74
855	2686.06	574145.69	923	2899.69	669103.47	991	3113.32	771324.61
856	2689.20	575489.51	924	2902.83	670554.10	992	3116.46	772882.06
857	2692.34	576834.90	925	2905.97	672006.30	993	3119.60	774441.07
858	2695.49	578181.85	926	2909.11	673460.08	994	3122.74	776001.66
859	2698.63	579530.38	927	2912.26	674915.42	995	3125.88	777563.82
860	2701.77	580880.48	928	2915.40	676372.33	996	3129.03	779127.54
861	2704.91	582232.15	929	2918.54	677830.82	997	3132.17	780692.84
862	2708.05	583585.39	930	2921.68	679290.87	998	3135.31	782259.71
863	2711.19	584940.20	931	2924.82	680752.50	999	3138.45	783828.15
864	2714.34	586296.59	932	2927.96	682215.69	1000	3141.59	785398.16
865	2717.48	587654.54	933	2931.11	683680.46			
866	2720.62	589014.07	934	2934.25	685146.80			

120 CIRCUMFERENCE OF CIRCLES, FEET AND INCHES.

CIRCUMFERENCE OF CIRCLES FROM 1 INCH TO 32 FT. 11 IN. DIAMETER.

Diam. Feet.	0 In.		1 Inch.		2 In.		3 In.		4 In.		5 In.		6 In.		7 In.		8 In.		9 In.		10 In.		11 In.		Diam. Feet.	
	Ft.	In.	Ft.	In.	Ft.	In.	Ft.	In.	Ft.	In.	Ft.	In.	Ft.	In.	Ft.	In.	Ft.	In.	Ft.	In.	Ft.	In.	Ft.	In.		
0																									0	
1	3	13/4	3	47/8	3	8	3	11/8	3	21/4	4	53/8	4	81/2	4	115/8	5	27/8	5	6	5	91/8	6	2	101/2	1
2	6	33/8	6	61/2	6	95/8	6	33/4	7	4	7	71/8	7	101/4	8	13/8	8	41/2	8	8	8	103/4	9	2	101/2	2
3	9	51/8	9	81/4	9	113/8	10	21/2	10	55/8	10	83/4	10	117/8	11	31/8	11	61/4	11	11	11	93/8	12	3	35/8	3
4	12	63/4	12	97/8	13	13/8	13	41/4	13	73/8	13	101/2	14	158	14	43/4	14	77/8	14	14	14	101/2	15	4	53/8	4
5	15	81/2	15	115/8	16	23/4	16	57/8	16	9	17	101/4	17	33/8	17	61/2	17	95/8	18	18	18	37/8	18	5	53/8	5
6	18	101/8	19	13/8	19	41/2	19	75/8	19	103/4	20	17/8	20	5	20	81/8	20	113/8	20	20	20	55/8	21	6	83/4	6
7	21	117/8	22	3	22	61/8	22	91/4	23	33/8	23	35/8	23	63/4	23	97/8	24	13/8	24	24	24	57/8	24	7	103/8	7
8	25	15/8	25	43/4	26	21/8	26	25/4	26	21/8	26	51/4	26	83/8	26	115/8	27	23/4	27	27	27	57/8	27	8	101/8	8
9	28	31/4	28	63/8	28	37/8	29	37/8	29	37/8	29	7	29	101/8	30	33/8	30	43/8	30	30	30	71/2	30	9	17/8	9
10	31	5	31	81/8	31	111/4	32	23/8	32	51/2	32	83/4	32	117/8	33	3	33	61/8	33	33	33	91/4	34	10	31/2	10
11	34	65/8	34	97/8	35	1	35	41/8	35	71/4	35	103/8	36	11/2	36	45/8	36	73/4	36	36	36	11	37	11	31/2	11
12	37	83/8	37	111/2	38	25/8	38	53/4	38	9	39	11/8	39	31/4	39	63/8	39	91/2	40	40	40	103/4	40	12	46/8	12
13	40	101/8	41	11/4	41	43/8	41	91/4	41	105/8	42	13/4	42	47/8	42	81/8	42	101/4	43	43	43	103/4	43	13	51/2	13
14	43	113/4	44	27/8	44	6	44	44	45	45	31/2	45	65/8	45	93/4	46	17/8	46	46	46	46	103/8	46	14	58/8	14
15	47	11/2	47	45/8	47	73/4	47	107/8	48	2	48	51/8	48	83/8	48	111/2	49	25/8	49	49	49	103/8	49	15	63/4	15
16	50	31/8	50	63/8	50	91/2	51	105/8	51	33/4	51	67/8	51	110	52	11/8	52	41/4	52	52	52	105/8	52	16	68/8	16
17	53	47/8	53	8	53	111/8	54	21/4	54	51/2	54	85/8	54	133/4	55	27/8	55	49	55	55	55	101/4	55	17	73/4	17
18	56	65/8	56	93/4	57	107/8	57	4	57	71/8	57	101/4	58	133/8	58	41/2	58	73/4	58	58	58	101/4	58	18	78/8	18
19	59	81/4	59	113/8	60	21/2	60	53/4	60	87/8	61	101/4	61	138	61	61/4	61	93/8	62	62	62	101/2	62	19	83/4	19
20	62	10	63	11/8	63	41/4	63	73/8	63	101/2	64	158	64	47/8	64	8	64	11/8	65	65	65	101/2	65	20	88/4	20
21	65	115/8	66	27/8	66	6	66	91/8	67	101/4	67	33/8	67	61/2	67	95/8	68	103/4	68	68	68	101/2	68	21	93/4	21
22	69	13/8	69	41/2	69	75/8	69	103/4	70	17/8	70	51/8	70	81/4	70	113/8	71	21/2	71	71	71	101/2	71	22	98/4	22
23	72	3	72	61/4	72	93/8	73	35/8	73	35/8	73	63/4	73	97/8	74	41/4	74	41/4	74	74	74	101/2	74	23	103/8	23
24	75	43/4	75	77/8	75	11	76	41/2	76	53/8	76	81/2	76	115/8	77	23/4	77	57/8	77	77	77	101/8	77	24	108/8	24
25	78	61/2	78	95/8	79	33/4	79	37/8	79	7	79	101/8	80	131/4	80	43/8	80	103/4	80	80	80	103/4	80	25	113/8	25
26	81	81/8	81	111/4	82	55/8	82	55/8	82	83/4	82	117/8	83	3	83	61/8	83	91/4	84	84	84	103/4	84	26	118/4	26
27	84	97/8	85	1	85	41/8	85	71/4	85	103/8	86	15/8	86	43/4	86	77/8	86	11	87	87	87	101/4	87	27	123/8	27
28	87	115/8	88	23/4	88	57/8	88	9	89	01/8	89	31/4	89	63/8	89	91/2	90	33/4	90	90	90	101/4	90	28	128/8	28
29	91	11/4	91	43/8	91	71/2	91	103/4	92	17/8	92	51/4	92	81/8	92	111/4	93	23/8	93	93	93	101/2	93	29	133/8	29
30	94	3	94	61/8	94	91/4	95	31/2	95	31/2	95	65/8	95	93/4	96	1	96	41/8	96	96	96	101/8	96	30	138/8	30
31	97	45/8	97	73/4	97	11	98	21/8	98	51/4	98	83/8	98	111/2	99	25/8	99	53/4	99	99	99	101/8	99	31	143/8	31
32	100	63/8	100	91/2	101	101/8	101	33/4	101	67/8	101	101/8	102	11/4	102	43/8	102	71/2	102	102	102	105/8	103	32	148/8	32

AREAS OF THE SEGMENTS OF A CIRCLE.

(Diameter = 1; Rise or Height in parts of Diameter being given.)

RULE FOR USE OF THE TABLE.—Divide the rise or height of the segment by the diameter. Multiply the area in the table corresponding to the quotient thus found by the square of the diameter.

If the segment exceeds a semicircle its area is area of circle — area of segment whose rise is (diam. of circle — rise of given segment).

Given chord and rise, to find diameter. Diam. = (square of half chord + rise) + rise. The half chord is a mean proportional between the two parts into which the chord divides the diameter which is perpendicular to it.

Rise + Diam.	Area.	Rise + Diam.	Area.	Rise + Diam.	Area.	Rise + Diam.	Area.	Rise + Diam.	Area.
.001	.00004	.054	.01646	.107	.04514	.16	.08111	.213	.12235
.002	.00012	.055	.01691	.108	.04576	.161	.08185	.214	.12317
.003	.00022	.056	.01737	.109	.04638	.162	.08258	.215	.12399
.004	.00034	.057	.01783	.11	.04701	.163	.08332	.216	.12481
.005	.00047	.058	.01830	.111	.04763	.164	.08406	.217	.12563
.006	.00062	.059	.01877	.112	.04826	.165	.08480	.218	.12646
.007	.00078	.06	.01924	.113	.04889	.166	.08554	.219	.12729
.008	.00095	.061	.01972	.114	.04953	.167	.08629	.22	.12811
.009	.00113	.062	.02020	.115	.05016	.168	.08704	.221	.12894
.01	.00133	.063	.02068	.116	.05080	.169	.08779	.222	.12977
.011	.00153	.064	.02117	.117	.05145	.17	.08854	.223	.13060
.012	.00175	.065	.02166	.118	.05209	.171	.08929	.224	.13144
.013	.00197	.066	.02215	.119	.05274	.172	.09004	.225	.13227
.014	.0022	.067	.02265	.12	.05338	.173	.09080	.226	.13311
.015	.00244	.068	.02315	.121	.05404	.174	.09155	.227	.13395
.016	.00268	.069	.02366	.122	.05469	.175	.09231	.228	.13478
.017	.00294	.07	.02417	.123	.05535	.176	.09307	.229	.13562
.018	.0032	.071	.02468	.124	.05600	.177	.09384	.23	.13646
.019	.00347	.072	.02520	.125	.05666	.178	.09460	.231	.13731
.02	.00375	.073	.02571	.126	.05733	.179	.09537	.232	.13815
.021	.00403	.074	.02624	.127	.05799	.18	.09613	.233	.13900
.022	.00432	.075	.02676	.128	.05866	.181	.09690	.234	.13984
.023	.00462	.076	.02729	.129	.05933	.182	.09767	.235	.14069
.024	.00492	.077	.02782	.13	.06000	.183	.09845	.236	.14154
.025	.00523	.078	.02836	.131	.06067	.184	.09922	.237	.14239
.026	.00555	.079	.02889	.132	.06135	.185	.10000	.238	.14324
.027	.00587	.08	.02943	.133	.06203	.186	.10077	.239	.14409
.028	.00619	.081	.02998	.134	.06271	.187	.10155	.24	.14494
.029	.00653	.082	.03053	.135	.06339	.188	.10233	.241	.14580
.03	.00687	.083	.03108	.136	.06407	.189	.10312	.242	.14666
.031	.00721	.084	.03163	.137	.06476	.19	.10390	.243	.14751
.032	.00756	.085	.03219	.138	.06545	.191	.10469	.244	.14837
.033	.00791	.086	.03275	.139	.06614	.192	.10547	.245	.14923
.034	.00827	.087	.03331	.14	.06683	.193	.10626	.246	.15009
.035	.00864	.088	.03387	.141	.06753	.194	.10705	.247	.15095
.036	.00901	.089	.03444	.142	.06822	.195	.10784	.248	.15182
.037	.00938	.09	.03501	.143	.06892	.196	.10864	.249	.15268
.038	.00976	.091	.03559	.144	.06963	.197	.10943	.25	.15355
.039	.01015	.092	.03616	.145	.07033	.198	.11023	.251	.15441
.04	.01054	.093	.03674	.146	.07103	.199	.11102	.252	.15528
.041	.01093	.094	.03732	.147	.07174	.2	.11182	.253	.15615
.042	.01133	.095	.03791	.148	.07245	.201	.11262	.254	.15702
.043	.01173	.096	.03850	.149	.07316	.202	.11343	.255	.15789
.044	.01214	.097	.03909	.15	.07387	.203	.11423	.256	.15876
.045	.01255	.098	.03968	.151	.07459	.204	.11504	.257	.15964
.046	.01297	.099	.04028	.152	.07531	.205	.11584	.258	.16051
.047	.01339	.1	.04087	.153	.07603	.206	.11665	.259	.16139
.048	.01382	.101	.04148	.154	.07675	.207	.11746	.26	.16226
.049	.01425	.102	.04208	.155	.07747	.208	.11827	.261	.16314
.05	.01468	.103	.04269	.156	.07819	.209	.11908	.262	.16402
.051	.01512	.104	.04330	.157	.07892	.21	.11990	.263	.16490
.052	.01556	.105	.04391	.158	.07965	.211	.12071	.264	.16578
.053	.01601	.106	.04452	.159	.08038	.212	.12153	.265	.16666



Rise ÷ Diam.	Area.	Rise ÷ Diam.	Area.	Rise ÷ Diam.	Area.	Rise ÷ Diam.	Area.	Rise ÷ Diam.	Area.
.266	.16755	.313	.21015	.36	.25455	.407	.30024	.454	.34676
.267	.16843	.314	.21108	.361	.25551	.408	.30122	.455	.34776
.268	.16932	.315	.21201	.362	.25647	.409	.30220	.456	.34876
.269	.17020	.316	.21294	.363	.25743	.41	.30319	.457	.34975
.27	.17109	.317	.21387	.364	.25839	.411	.30417	.458	.35075
.271	.17198	.318	.21480	.365	.25936	.412	.30516	.459	.35175
.272	.17287	.319	.21573	.366	.26032	.413	.30614	.46	.35274
.273	.17376	.32	.21667	.367	.26128	.414	.30712	.461	.35374
.274	.17465	.321	.21760	.368	.26225	.415	.30811	.462	.35474
.275	.17554	.322	.21853	.369	.26321	.416	.30910	.463	.35573
.276	.17644	.323	.21947	.37	.26418	.417	.31008	.464	.35673
.277	.17733	.324	.22040	.371	.26514	.418	.31107	.465	.35773
.278	.17823	.325	.22134	.372	.26611	.419	.31205	.466	.35873
.279	.17912	.326	.22228	.373	.26708	.42	.31304	.467	.35972
.28	.18002	.327	.22322	.374	.26805	.421	.31403	.468	.36072
.281	.18092	.328	.22415	.375	.26901	.422	.31502	.469	.36172
.282	.18182	.329	.22509	.376	.26998	.423	.31600	.47	.36272
.283	.18272	.33	.22603	.377	.27095	.424	.31699	.471	.36372
.284	.18362	.331	.22697	.378	.27192	.425	.31798	.472	.36471
.285	.18452	.332	.22792	.379	.27289	.426	.31897	.473	.36571
.286	.18542	.333	.22886	.38	.27386	.427	.31996	.474	.36671
.287	.18633	.334	.22980	.381	.27483	.428	.32095	.475	.36771
.288	.18723	.335	.23074	.382	.27580	.429	.32194	.476	.36871
.289	.18814	.336	.23169	.383	.27678	.43	.32293	.477	.36971
.29	.18905	.337	.23263	.384	.27775	.431	.32392	.478	.37071
.291	.18996	.338	.23358	.385	.27872	.432	.32491	.479	.37171
.292	.19086	.339	.23453	.386	.27969	.433	.32590	.48	.37270
.293	.19177	.34	.23547	.387	.28067	.434	.32689	.481	.37370
.294	.19268	.341	.23642	.388	.28164	.435	.32788	.482	.37470
.295	.19360	.342	.23737	.389	.28262	.436	.32887	.483	.37570
.296	.19451	.343	.23832	.39	.28359	.437	.32987	.484	.37670
.297	.19542	.344	.23927	.391	.28457	.438	.33086	.485	.37770
.298	.19634	.345	.24022	.392	.28554	.439	.33185	.486	.37870
.299	.19725	.346	.24117	.393	.28652	.44	.33284	.487	.37970
.3	.19817	.347	.24212	.394	.28750	.441	.33384	.488	.38070
.301	.19908	.348	.24307	.395	.28848	.442	.33483	.489	.38170
.302	.20000	.349	.24403	.396	.28945	.443	.33582	.49	.38270
.303	.20092	.35	.24498	.397	.29043	.444	.33682	.491	.38370
.304	.20184	.351	.24593	.398	.29141	.445	.33781	.492	.38470
.305	.20276	.352	.24689	.399	.29239	.446	.33880	.493	.38570
.306	.20368	.353	.24784	.4	.29337	.447	.33980	.494	.38670
.307	.20460	.354	.24880	.401	.29435	.448	.34079	.495	.38770
.308	.20553	.355	.24976	.402	.29533	.449	.34179	.496	.38870
.309	.20645	.356	.25071	.403	.29631	.45	.34278	.497	.38970
.31	.20738	.357	.25167	.404	.29729	.451	.34378	.498	.39070
.311	.20830	.358	.25263	.405	.29827	.452	.34477	.499	.39170
.312	.20923	.359	.25359	.406	.29926	.453	.34577	.5	.39270

For rules for finding the area of a segment see Mensuration, page 60.

### LENGTHS OF CIRCULAR ARCS.

(Degrees being given. Radius of Circle = 1.)

FORMULA. — Length of arc =  $\frac{3.1415927}{180} \times \text{radius} \times \text{number of degrees}$ .

RULE. — Multiply the factor in the table (see next page) for any given number of degrees by the radius.

EXAMPLE. — Given a curve of a radius of 55 feet and an angle of 78° 20'.

Factor from table for 78°..... 1.3613568

Factor from table for 20'..... .0058178

Factor..... 1.3671746

1.3671746 × 55 = 75.19 feet.



FACTORS FOR LENGTHS OF CIRCULAR ARCS.

Degrees.					Minutes.		
1	.0174533	61	1.0646508	121	2.1118484	1	.0002909
2	.0349066	62	1.0821041	122	2.1293017	2	.0005818
3	.0523599	63	1.0995574	123	2.1467550	3	.0008727
4	.0698132	64	1.1170107	124	2.1642083	4	.0011636
5	.0872665	65	1.1344640	125	2.1816616	5	.0014544
6	.1047198	66	1.1519173	126	2.1991149	6	.0017453
7	.1221730	67	1.1693706	127	2.2165682	7	.0020362
8	.1396263	68	1.1868239	128	2.2340214	8	.0023271
9	.1570796	69	1.2042772	129	2.2514747	9	.0026180
10	.1745329	70	1.2217305	130	2.2689280	10	.0029089
11	.1919862	71	1.2391838	131	2.2863813	11	.0031998
12	.2094395	72	1.2566371	132	2.3038346	12	.0034907
13	.2268928	73	1.2740904	133	2.3212879	13	.0037815
14	.2443461	74	1.2915436	134	2.3387412	14	.0040724
15	.2617994	75	1.3089969	135	2.3561945	15	.0043633
16	.2792527	76	1.3264502	136	2.3736478	16	.0046542
17	.2967060	77	1.3439035	137	2.3911011	17	.0049451
18	.3141593	78	1.3613568	138	2.4085544	18	.0052360
19	.3316126	79	1.3788101	139	2.4260077	19	.0055269
20	.3490659	80	1.3962634	140	2.4434610	20	.0058178
21	.3665191	81	1.4137167	141	2.4609142	21	.0061087
22	.3839724	82	1.4311700	142	2.4783675	22	.0063995
23	.4014257	83	1.4486233	143	2.4958208	23	.0066904
24	.4188790	84	1.4660766	144	2.5132741	24	.0069813
25	.4363323	85	1.4835299	145	2.5307274	25	.0072722
26	.4537856	86	1.5009832	146	2.5481807	26	.0075631
27	.4712389	87	1.5184364	147	2.5656340	27	.0078540
28	.4886922	88	1.5358897	148	2.5830873	28	.0081449
29	.5061455	89	1.5533430	149	2.6005406	29	.0084358
30	.5235988	90	1.5707963	150	2.6179939	30	.0087266
31	.5410521	91	1.5882496	151	2.6354472	31	.0090175
32	.5585054	92	1.6057029	152	2.6529005	32	.0093084
33	.5759587	93	1.6231562	153	2.6703538	33	.0095993
34	.5934119	94	1.6406095	154	2.6878071	34	.0098902
35	.6108652	95	1.6580628	155	2.7052603	35	.0101811
36	.6283185	96	1.6755161	156	2.7227136	36	.0104720
37	.6457718	97	1.6929694	157	2.7401669	37	.0107629
38	.6632251	98	1.7104227	158	2.7576202	38	.0110538
39	.6806784	99	1.7278760	159	2.7750735	39	.0113446
40	.6981317	100	1.7453293	160	2.7925268	40	.0116355
41	.7155850	101	1.7627825	161	2.8099801	41	.0119264
42	.7330383	102	1.7802358	162	2.8274334	42	.0122173
43	.7504916	103	1.7976891	163	2.8448867	43	.0125082
44	.7679449	104	1.8151424	164	2.8623400	44	.0127991
45	.7853982	105	1.8325957	165	2.8797933	45	.0130900
46	.8028515	106	1.8500490	166	2.8972466	46	.0133809
47	.8203047	107	1.8675023	167	2.9146999	47	.0136717
48	.8377580	108	1.8849556	168	2.9321531	48	.0139626
49	.8552113	109	1.9024089	169	2.9496064	49	.0142535
50	.8726646	110	1.9198622	170	2.9670597	50	.0145444
51	.8901179	111	1.9373155	171	2.9845130	51	.0148353
52	.9075712	112	1.9547688	172	3.0019663	52	.0151262
53	.9250245	113	1.9722221	173	3.0194196	53	.0154171
54	.9424778	114	1.9896753	174	3.0368729	54	.0157080
55	.9599311	115	2.0071286	175	3.0543262	55	.0159989
56	.9773844	116	2.0245819	176	3.0717795	56	.0162897
57	.9948377	117	2.0420352	177	3.0892328	57	.0165806
58	1.0122910	118	2.0594885	178	3.1066861	58	.0168715
59	1.0297443	119	2.0769418	179	3.1241394	59	.0171624
60	1.0471976	120	2.0943951	180	3.1415927	60	.0174533



**Diameters of Circles and Sides of Squares of Same Area.**

Diameter of circle = 1.128379 × side of square of same area.

Side of square = 0.886227 × diameter of circle of same area.

Diam. of Circle or Side of Square.	Side of Square Equivalent to Circle.	Diam. of Circle Equivalent to Square.	Diam. of Circle or Side of Square.	Side of Square Equivalent to Circle.	Diam. of Circle Equivalent to Square.	Diam. of Circle or Side of Square.	Side of Square Equivalent to Circle.	Diam. of Circle Equivalent to Square.
1	0.886	1.128	34	30.132	38.365	67	59.377	75.601
2	1.772	2.257	35	31.018	39.493	68	60.263	76.730
3	2.689	3.385	36	31.904	40.622	69	61.150	77.858
4	3.545	4.514	37	32.790	41.750	70	62.036	78.987
5	4.431	5.642	38	33.677	42.878	71	62.922	80.115
6	5.317	6.770	39	34.563	44.007	72	63.808	81.243
7	6.204	7.899	40	35.449	45.135	73	64.695	82.372
8	7.090	9.027	41	36.335	46.264	74	65.581	83.500
9	7.976	10.155	42	37.222	47.392	75	66.467	84.628
10	8.862	11.284	43	38.108	48.520	76	67.353	85.757
11	9.748	12.412	44	38.994	49.649	77	68.239	86.885
12	10.635	13.541	45	39.880	50.777	78	69.126	88.104
13	11.521	14.669	46	40.766	51.905	79	70.012	89.142
14	12.407	15.797	47	41.653	53.034	80	70.898	90.270
15	13.293	16.926	48	42.539	54.162	81	71.784	91.399
16	14.180	18.054	49	43.425	55.291	82	72.671	92.527
17	15.066	19.182	50	44.311	56.419	83	73.557	93.655
18	15.952	20.311	51	45.198	57.547	84	74.443	94.784
19	16.838	21.439	52	46.084	58.676	85	75.330	95.912
20	17.725	22.568	53	46.970	59.804	86	76.216	97.041
21	18.611	23.696	54	47.856	60.932	87	77.102	98.169
22	19.497	24.824	55	48.742	62.061	88	77.988	99.297
23	20.383	25.953	56	49.629	63.189	89	78.874	100.426
24	21.269	27.081	57	50.515	64.318	90	79.760	101.554
25	22.156	28.209	58	51.401	65.446	91	80.647	102.682
26	23.042	29.338	59	52.287	66.574	92	81.533	103.811
27	23.928	30.466	60	53.174	67.703	93	82.419	104.939
28	24.814	31.595	61	54.060	68.831	94	83.305	106.068
29	25.701	32.723	62	54.946	69.959	95	84.192	107.196
30	26.587	33.851	63	55.832	71.088	96	85.078	108.324
31	27.473	34.980	64	56.719	72.216	97	85.964	109.453
32	28.359	36.108	65	57.605	73.345	98	86.850	110.581
33	29.245	37.237	66	58.491	74.473	99	87.736	111.710

**Number of Circles that can be Inscribed within a Larger Circle.**

$N$  = Number of circles;  $D$  = diam. of enclosing circle;  $d$  = diam. of inscribed circles.

Obtain the ratio of  $D \div d$  and find the value nearest to it in the table. Opposite this value under  $N$ , find the number of circles of diameter  $d$  that can be inscribed in a circle of diameter  $D$ .

$N$	$D/d$	$N$	$D/d$	$N$	$D/d$	$N$	$D/d$	$N$	$D/d$	$N$	$D/d$	$N$	$D/d$
2	2.00	13	4.23	24	5.72	35	6.86	46	7.81	85	10.46	140	13.26
3	2.15	14	4.41	25	5.81	36	7.00	47	7.92	90	10.73	145	13.49
4	2.41	15	4.55	26	5.92	37	7.00	48	8.00	95	11.15	150	13.72
5	2.70	16	4.70	27	6.00	38	7.08	49	8.03	100	11.34	155	13.95
6	3.00	17	4.86	28	6.13	39	7.18	50	8.13	105	11.60	160	14.17
7	3.00	18	5.00	29	6.23	40	7.31	55	8.21	110	11.85	165	14.39
8	3.31	19	5.00	30	6.40	41	7.39	60	8.94	115	12.10	170	14.60
9	3.61	20	5.18	31	6.44	42	7.43	65	9.25	120	12.34	175	14.81
10	3.80	21	5.31	32	6.55	43	7.61	70	9.61	125	12.57	180	15.01
11	3.92	22	5.49	33	6.70	44	7.70	75	9.93	130	12.80	185	15.20
12	4.05	23	5.61	34	6.76	45	7.72	80	10.20	135	13.06	190	15.39



SPHERES.

(Some errors of 1 in the last figure only. From TRAUTWINE.)

Diam.	Sur- face.	Vol- ume.	Diam.	Sur- face.	Vol- ume.	Diam.	Sur- face.	Vol- ume.
1/32	.00307	.00002	3 1/4	33.183	17.974	9 7/8	306.36	504.21
1/16	.01227	.00013	5/16	34.472	19.031	10.	314.16	523.60
3/32	.02761	.00043	3/8	35.784	20.129	1 1/8	322.06	543.48
1/8	.04909	.00102	7/16	37.122	21.268	1/4	330.06	563.86
5/32	.07670	.00200	1/2	38.484	22.449	3/8	333.16	584.74
3/16	.11045	.00345	9/16	39.872	23.674	1/2	346.36	606.13
7/32	.15033	.00548	5/8	41.283	24.942	5/8	354.66	628.04
1/4	.19635	.00818	11/16	42.719	26.254	3/4	363.05	650.46
9/32	.24851	.01165	3/4	44.179	27.611	7/8	371.54	673.42
5/16	.30680	.01598	13/16	45.664	29.016	11.	380.13	696.91
11/32	.37123	.02127	7/8	47.173	30.466	1 1/8	388.83	720.95
3/8	.44179	.02761	15/16	48.708	31.965	1/4	397.61	745.51
13/32	.51848	.03511	4.	50.265	33.510	3/8	406.49	770.64
7/16	.60132	.04385	1 1/8	53.456	36.751	1/2	415.48	796.33
15/32	.69028	.05393	1/4	56.745	40.195	5/8	424.50	822.58
1/2	.78540	.06545	3/8	60.133	43.847	3/4	433.73	849.40
9/16	.99403	.09319	1/2	63.617	47.713	7/8	443.01	876.79
5/8	1.2272	.12783	5/8	67.201	51.801	12.	452.39	904.78
11/16	1.4849	.17014	3/4	70.883	56.116	1/4	471.44	962.52
3/4	1.7671	.22089	7/8	74.663	60.663	1/2	490.87	1022.7
13/16	2.0739	.28084	5.	78.540	65.450	3/4	510.71	1085.3
7/8	2.4053	.35077	1 1/8	82.516	70.482	13.	530.93	1150.3
15/16	2.7611	.43143	1/4	86.591	75.767	1/4	551.55	1218.0
1	3.1416	.52360	3/8	90.763	81.308	1/2	572.55	1288.3
1/16	3.5466	.62804	1/2	95.033	87.113	3/4	593.95	1361.2
1/8	3.9761	.74551	5/8	99.401	93.189	14.	615.75	1436.8
3/16	4.4301	.87681	3/4	103.87	99.541	1/4	637.95	1515.1
1/4	4.9088	1.0227	7/8	108.44	106.18	1/2	660.52	1596.3
5/16	5.4119	1.1839	6.	113.10	113.10	3/4	683.49	1680.3
3/8	5.9396	1.3611	1 1/8	117.87	120.31	15.	706.85	1767.2
7/16	6.4919	1.5553	1/4	122.72	127.83	1/4	730.63	1857.0
1/2	7.0686	1.7671	3/8	127.68	135.66	1/2	754.77	1949.8
9/16	7.6699	1.9974	1/2	132.73	143.79	3/4	779.32	2045.7
5/8	8.2957	2.2468	5/8	137.89	152.25	16.	804.25	2144.7
11/16	8.9461	2.5161	3/4	143.14	161.03	1/4	829.57	2246.8
3/4	9.6211	2.8062	7/8	148.49	170.14	1/2	855.29	2352.1
13/16	10.321	3.1177	7.	153.94	179.59	3/4	881.42	2460.6
7/8	11.044	3.4514	1 1/8	159.49	189.39	17.	907.93	2572.4
15/16	11.793	3.8083	1/4	165.13	199.53	1/4	934.83	2687.6
2.	12.566	4.1888	3/8	170.87	210.03	1/2	962.12	2806.2
1/16	13.364	4.5939	1/2	176.71	220.89	3/4	989.80	2928.2
1/8	14.186	5.0243	5/8	182.66	232.13	18.	1017.9	3053.6
3/16	15.033	5.4809	3/4	188.69	243.73	1/4	1046.4	3182.6
1/4	15.904	5.9641	7/8	194.83	255.72	1/2	1075.2	3315.3
5/16	16.800	6.4751	8.	201.06	268.08	3/4	1104.5	3451.5
3/8	17.721	7.0144	1 1/8	207.39	280.85	19.	1134.1	3591.4
1/2	18.666	7.5829	1/4	213.82	294.01	1/4	1164.2	3735.0
3/4	19.635	8.1813	3/8	220.36	307.58	1/2	1194.6	3882.5
9/16	20.629	8.8103	1/2	226.98	321.56	3/4	1225.4	4033.7
5/8	21.648	9.4708	5/8	233.71	335.95	20.	1256.7	4188.8
11/16	22.691	10.154	3/4	240.53	350.77	1/4	1288.3	4347.8
3/4	23.758	10.889	7/8	247.45	366.02	1/2	1320.3	4510.9
13/16	24.850	11.649	9.	254.47	381.70	3/4	1352.7	4677.9
7/8	25.967	12.443	1 1/8	261.59	397.83	21.	1385.5	4849.1
15/16	27.109	13.272	1/4	268.81	414.41	1/4	1418.6	5024.3
1	28.274	14.137	3/8	270.12	431.44	1/2	1452.2	5203.7
1/16	29.465	15.039	1/2	283.53	448.92	3/4	1486.2	5387.4
1/8	30.680	15.979	5/8	291.04	466.87	22.	1520.5	5575.3
3/16	31.919	16.957	3/4	289.65	485.31	1/4	1555.3	5767.6



SPHERES — *Continued.*

Diam	Surface.	Volume.	Diam	Surface	Volume	Diam.	Surface.	Volume.
22 1/2	1590.4	5964.1	40 1/2	5153.1	34783	70 1/2	15615	183471
3/4	1626.0	6165.2	41.	5281.1	36087	71.	15837	187402
23.	1661.9	6370.6	42.	5410.7	37423	72.	16061	191389
1/4	1698.2	6580.6	43.	5541.9	38792	73.	16286	195433
1/2	1735.0	6795.2	44.	5674.5	40194	74.	16513	199532
3/4	1772.1	7014.3	45.	5808.8	41630	75.	16742	203689
24.	1809.6	7238.2	46.	5944.7	43099	76.	16972	207903
1/4	1847.5	7466.7	47.	6082.1	44602	77.	17204	212175
1/2	1885.8	7700.1	48.	6221.2	46141	78.	17437	216505
3/4	1924.4	7938.3	49.	6361.7	47713	79.	17672	220894
25.	1963.5	8181.3	50.	6503.9	49321	80.	17908	225341
1/4	2002.9	8429.2	51.	6647.6	50965	81.	18146	229848
1/2	2042.8	8682.0	52.	6792.9	52645	82.	18386	234414
3/4	2083.0	8939.9	53.	6939.9	54362	83.	18626	239041
26.	2123.7	9202.8	54.	7088.3	56115	84.	18869	243728
1/4	2164.7	9470.8	55.	7238.3	57906	85.	19114	248475
1/2	2206.2	9744.0	56.	7389.9	59734	86.	19360	253284
3/4	2248.0	10022	57.	7543.1	61601	87.	19607	258155
27.	2290.2	10306	58.	7697.7	63506	88.	19856	263088
1/4	2332.8	10595	59.	7854.0	65450	89.	20106	268083
1/2	2375.8	10889	60.	8011.8	67433	90.	20358	273141
3/4	2419.2	11189	61.	8171.2	69456	91.	20612	278263
28.	2463.0	11494	62.	8332.3	71519	92.	20867	283447
1/4	2507.2	11805	63.	8494.8	73622	93.	21124	288696
1/2	2551.8	12121	64.	8658.9	75767	94.	21382	294010
3/4	2596.7	12443	65.	8824.8	77952	95.	21642	299388
29.	2642.1	12770	66.	8992.0	80178	96.	21904	304831
1/4	2687.8	13103	67.	9160.8	82448	97.	22167	310340
1/2	2734.0	13442	68.	9331.2	84760	98.	22432	315915
3/4	2780.5	13787	69.	9503.2	87114	99.	22698	321556
30.	2827.4	14137	70.	9676.8	89511	100.	22966	327264
1/4	2874.8	14494		9852.0	91953		23235	333039
1/2	2922.5	14856		10029	94438		23506	338882
3/4	2970.6	15224		10207	96967		23779	344792
31.	3019.1	15599		10387	99541		24053	350771
1/4	3068.0	15979		10568	102161		24328	356819
1/2	3117.3	16366		10751	104826		24606	362935
3/4	3166.9	16758		10936	107536		24885	369122
32.	3217.0	17157		11122	110294		25165	375378
1/4	3267.4	17563		11310	113098		25447	381704
1/2	3318.3	17974		11499	115949		25730	388102
3/4	3369.6	18392		11690	118847		26016	394570
33.	3421.2	18817		11882	121794		26302	401109
1/4	3473.3	19248		12076	124789		26590	407721
1/2	3525.7	19685		12272	127832		26880	414405
3/4	3578.5	20129		12469	130925		27172	421161
34.	3631.7	20580		12668	134067		27464	427991
1/4	3685.3	21037		12868	137259		27759	434894
1/2	3739.3	21501		13070	140501		28055	441871
35.	3848.5	22449		13273	143794		28353	448920
1/2	3959.2	23425		13478	147138		28652	456047
36.	4071.5	24429		13685	150533		28953	463248
1/2	4185.5	25461		13893	153980		29255	470524
37.	4300.9	26522		14103	157480		29559	477874
1/2	4417.9	27612		14314	161032		29865	485302
38.	4536.5	28731		14527	164637		30172	492808
1/2	4656.7	29880		14741	168295		30481	500388
39.	4778.4	31059		14957	172007		30791	508047
1/2	4901.7	32270		15175	175774		31103	515785
40.	5026.5	33510		15394	179595		31416	523598

**NUMBER OF SQUARE FEET IN PLATES 3 TO 32 FEET  
LONG, AND 1 INCH WIDE.**

For other widths, multiply by the width in inches. 1 sq. in. = 0.00694/9 sq. ft.

Ft. and Ins. Long.	Ins. Long.	Square Feet.	Ft. and Ins. Long.	Ins. Long.	Square Feet.	Ft. and Ins. Long.	Ins. Long.	Square Feet.
3.	0	.25	7.	10	.6528	12.	8	152
	1	.2569		11	.6597		9	153
	2	.2639	8.	0	.6667		10	154
	3	.2708		1	.6736		11	155
	4	.2778		2	.6806	13.	0	156
	5	.2847		3	.6875		1	157
	6	.2917		4	.6944		2	158
	7	.2986		5	.7014		3	159
	8	.3056		6	.7083		4	160
	9	.3125		7	.7153		5	161
	10	.3194		8	.7222		6	162
	11	.3264		9	.7292		7	163
4.	0	.3333		10	.7361		8	164
	1	.3403		11	.7431		9	165
	2	.3472	9.	0	.75		10	166
	3	.3542		1	.7569		11	167
	4	.3611		2	.7639	14.	0	168
	5	.3681		3	.7708		1	169
	6	.375		4	.7778		2	170
	7	.3819		5	.7847		3	171
	8	.3889		6	.7917		4	172
	9	.3958		7	.7986		5	173
	10	.4028		8	.8056		6	174
	11	.4097		9	.8125		7	175
5.	0	.4167		10	.8194		8	176
	1	.4236		11	.8264		9	177
	2	.4306	10.	0	.8333		10	178
	3	.4375		1	.8403		11	179
	4	.4444		2	.8472	15.	0	180
	5	.4514		3	.8542		1	181
	6	.4583		4	.8611		2	182
	7	.4653		5	.8681		3	183
	8	.4722		6	.875		4	184
	9	.4792		7	.8819		5	185
	10	.4861		8	.8889		6	186
	11	.4931		9	.8958		7	187
6.	0	.5		10	.9028		8	188
	1	.5069		11	.9097		9	189
	2	.5139	11.	0	.9167		10	190
	3	.5208		1	.9236		11	191
	4	.5278		2	.9306	16.	0	192
	5	.5347		3	.9375		1	193
	6	.5417		4	.9444		2	194
	7	.5486		5	.9514		3	195
	8	.5556		6	.9583		4	196
	9	.5625		7	.9653		5	197
	10	.5694		8	.9722		6	198
	11	.5764		9	.9792		7	199
7.	0	.5834		10	.9861		8	200
	1	.5903		11	.9931		9	201
	2	.5972	12.	0	1.000		10	202
	3	.6042		1	1.007		11	203
	4	.6111		2	1.014	17.	0	204
	5	.6181		3	1.021		1	205
	6	.625		4	1.028		2	206
	7	.6319		5	1.035		3	207
	8	.6389		6	1.042		4	208
	9	.6458		7	1.049		5	209

SQUARE FEET IN PLATES. — *Continued.*

Ft. and Ins. Long.	Ins. Long.	Square Feet.	Ft. and Ins. Long.	Ins. Long.	Square Feet.	Ft. and Ins. Long.	Ins. Long.	Square Feet.
17. 6	210	1.458	22. 5	269	1.868	27. 4	328	2.278
7	211	1.465	6	270	1.875	5	329	2.285
8	212	1.472	7	271	1.882	6	330	2.292
9	213	1.479	8	272	1.889	7	331	2.299
10	214	1.486	9	273	1.896	8	332	2.306
11	215	1.493	10	274	1.903	9	333	2.313
18. 0	216	1.5	11	275	1.91	10	334	2.319
1	217	1.507	23. 0	276	1.917	11	335	2.326
2	218	1.514	1	277	1.924	28. 0	336	2.333
3	219	1.521	2	278	1.931	1	337	2.34
4	220	1.528	3	279	1.938	2	338	2.347
5	221	1.535	4	280	1.944	3	339	2.354
6	222	1.542	5	281	1.951	4	340	2.361
7	223	1.549	6	282	1.958	5	341	2.368
8	224	1.556	7	283	1.965	6	342	2.375
9	225	1.563	8	284	1.972	7	343	2.382
10	226	1.569	9	285	1.979	8	344	2.389
11	227	1.576	10	286	1.986	9	345	2.396
19. 0	228	1.583	11	287	1.993	10	346	2.403
1	229	1.59	24. 0	288	2.	11	347	2.41
2	230	1.597	1	289	2.007	29. 0	348	2.417
3	231	1.604	2	290	2.014	1	349	2.424
4	232	1.611	3	291	2.021	2	350	2.431
5	233	1.618	4	292	2.028	3	351	2.438
6	234	1.625	5	293	2.035	4	352	2.444
7	235	1.632	6	294	2.042	5	353	2.451
8	236	1.639	7	295	2.049	6	354	2.458
9	237	1.645	8	296	2.056	7	355	2.465
10	238	1.653	9	297	2.063	8	356	2.472
11	239	1.659	10	298	2.069	9	357	2.479
20. 0	240	1.667	11	299	2.076	10	358	2.486
1	241	1.674	25. 0	300	2.083	11	359	2.493
2	242	1.681	1	301	2.09	30. 0	360	2.5
3	243	1.688	2	302	2.097	1	361	2.507
4	244	1.694	3	303	2.104	2	362	2.514
5	245	1.701	4	304	2.111	3	363	2.521
6	246	1.708	5	305	2.118	4	364	2.528
7	247	1.715	6	306	2.125	5	365	2.535
8	248	1.722	7	307	2.132	6	366	2.542
9	249	1.729	8	308	2.139	7	367	2.549
10	250	1.736	9	309	2.146	8	368	2.556
11	251	1.743	10	310	2.153	9	369	2.563
21. 0	252	1.75	11	311	2.16	10	370	2.569
1	253	1.757	26. 0	312	2.167	11	371	2.576
2	254	1.764	1	313	2.174	31. 0	372	2.583
3	255	1.771	2	314	2.181	1	373	2.59
4	256	1.778	3	315	2.188	2	374	2.597
5	257	1.785	4	316	2.194	3	375	2.604
6	258	1.792	5	317	2.201	4	376	2.611
7	259	1.799	6	318	2.208	5	377	2.618
8	260	1.806	7	319	2.215	6	378	2.625
9	261	1.813	8	320	2.222	7	379	2.632
10	262	1.819	9	321	2.229	8	380	2.639
11	263	1.826	10	322	2.236	9	381	2.646
22. 0	264	1.833	11	323	2.243	10	382	2.653
1	265	1.84	27. 0	324	2.25	11	383	2.66
2	266	1.847	1	325	2.257	32. 0	384	2.667
3	267	1.854	2	326	2.264	1	385	2.674
4	268	1.861	3	327	2.271	2	386	2.681

## GALLONS AND CUBIC FEET.

## United States Gallons in a given Number of Cubic Feet.

1 cubic foot = 7.480519 U.S. gallons; 1 gallon = 231 cu. in. = 0.13368056 cu. ft.

Cubic Ft.	Gallons.	Cubic Ft.	Gallons.	Cubic Ft.	Gallons.
0.1	0.75	50	374.0	8,000	59,844.2
0.2	1.50	60	448.8	9,000	67,324.7
0.3	2.24	70	523.6	10,000	74,805.2
0.4	2.99	80	598.4	20,000	149,610.4
0.5	3.74	90	673.2	30,000	224,415.6
0.6	4.49	100	748.0	40,000	299,220.8
0.7	5.24	200	1,496.1	50,000	374,025.9
0.8	5.98	300	2,244.2	60,000	448,831.1
0.9	6.73	400	2,992.2	70,000	523,636.3
1	7.48	500	3,740.3	80,000	598,441.5
2	14.96	600	4,488.3	90,000	673,246.
3	22.44	700	5,236.4	100,000	748,051.9
4	29.92	800	5,984.4	200,000	1,496,103.8
5	37.40	900	6,732.5	300,000	2,244,155.7
6	44.88	1,000	7,480.5	400,000	2,992,207.6
7	52.36	2,000	14,961.0	500,000	3,740,259.5
8	59.84	3,000	22,441.6	600,000	4,488,311.4
9	67.32	4,000	29,922.1	700,000	5,236,363.3
10	74.80	5,000	37,402.6	800,000	5,984,415.2
20	149.6	6,000	44,883.1	900,000	6,732,467.1
30	224.4	7,000	52,363.6	1,000,000	7,480,519.0
40	299.2				

## Cubic Feet in a given Number of Gallons.

Gallons.	Cubic Ft.	Gallons.	Cubic Ft.	Gallons.	Cubic Ft.
1	.134	1,000	133.681	1,000,000	133,680.6
2	.267	2,000	267.361	2,000,000	267,361.1
3	.401	3,000	401.042	3,000,000	401,041.7
4	.535	4,000	534.722	4,000,000	534,722.2
5	.668	5,000	668.403	5,000,000	668,402.8
6	.802	6,000	802.083	6,000,000	802,083.3
7	.936	7,000	935.764	7,000,000	935,763.9
8	1.069	8,000	1,069.444	8,000,000	1,069,444.4
9	1.203	9,000	1,203.125	9,000,000	1,203,125.0
10	1.337	10,000	1,336.806	10,000,000	1,336,805.6

## Cubic Feet per Second, Gallons in 24 hours, etc.

Cu. ft. per sec.	$\frac{1}{60}$	1	1.5472	2.2800
Cu. ft. per min.	1	60	92.834	133.681
U. S. Gals. per min.	7.480519	448.83	694.444	1,000.
" " " 24 hrs.	10,771.95	646,317	1,000,000	1,440,000
Pounds of water (at 62° F.) per min. }	62.355	3741.3	5788.66	8335.65

The gallon is a troublesome and unnecessary measure. If hydraulic engineers and pump manufacturers would stop using it, and use cubic feet instead, many tedious calculations would be saved.



**CONTENTS IN CUBIC FEET AND U. S. GALLONS OF PIPES  
AND CYLINDERS OF VARIOUS DIAMETERS AND ONE  
FOOT IN LENGTH.**

1 gallon = 231 cubic inches. 1 cubic foot = 7.4805 gallons.

Diameter in Inches.	For 1 Foot in Length.		Diameter in Inches.	For 1 Foot in Length.		Diameter in Inches.	For 1 Foot in Length.	
	Cu. Ft. also Area in Sq. Ft.	U.S. Gals., 231 Cu. In.		Cu. Ft. also Area in Sq. Ft.	U.S. Gals., 231 Cu. In.		Cu. Ft. also Area in Sq. Ft.	U.S. Gals., 231 Cu. In.
1/4	.0003	.0025	63/4	.2485	1.859	19	1.969	14.73
5/16	.0005	.004	7	.2673	1.999	19 1/2	2.074	15.51
3/8	.0008	.0057	7 1/4	.2867	2.145	20	2.182	16.32
7/16	.001	.0078	7 1/2	.3068	2.295	20 1/2	2.292	17.15
1/2	.0014	.0102	7 3/4	.3276	2.45	21	2.405	17.99
9/16	.0017	.0129	8	.3491	2.611	21 1/2	2.521	18.86
5/8	.0021	.0159	8 1/4	.3712	2.777	22	2.640	19.75
11/16	.0026	.0193	8 1/2	.3941	2.948	22 1/2	2.761	20.66
3/4	.0031	.0230	8 3/4	.4176	3.125	23	2.885	21.58
13/16	.0036	.0269	9	.4418	3.305	23 1/2	3.012	22.53
7/8	.0042	.0312	9 1/4	.4667	3.491	24	3.142	23.50
15/16	.0048	.0359	9 1/2	.4922	3.682	25	3.409	25.50
1	.0055	.0408	9 3/4	.5185	3.879	26	3.687	27.58
1 1/4	.0085	.0638	10	.5454	4.08	27	3.976	29.74
1 1/2	.0123	.0918	10 1/4	.5730	4.286	28	4.276	31.99
1 3/4	.0167	.1249	10 1/2	.6013	4.498	29	4.587	34.31
2	.0218	.1632	10 3/4	.6303	4.715	30	4.909	36.72
2 1/4	.0276	.2066	11	.66	4.937	31	5.241	39.21
2 1/2	.0341	.2550	11 1/4	.6903	5.164	32	5.585	41.78
2 3/4	.0412	.3085	11 1/2	.7213	5.396	33	5.940	44.43
3	.0491	.3672	11 3/4	.7530	5.633	34	6.305	47.16
3 1/4	.0576	.4309	12	.7854	5.875	35	6.681	49.98
3 1/2	.0668	.4998	12 1/2	.8522	6.375	36	7.069	52.88
3 3/4	.0767	.5738	13	.9218	6.895	37	7.467	55.86
4	.0873	.6528	13 1/2	.994	7.436	38	7.876	58.92
4 1/4	.0985	.7369	14	1.069	7.997	39	8.296	62.06
4 1/2	.1104	.8263	14 1/2	1.147	8.578	40	8.727	65.28
4 3/4	.1231	.9206	15	1.227	9.180	41	9.168	68.58
5	.1364	1.020	15 1/2	1.310	9.801	42	9.621	71.97
5 1/4	.1503	1.125	16	1.396	10.44	43	10.085	75.44
5 1/2	.1650	1.234	16 1/2	1.485	11.11	44	10.559	78.99
5 3/4	.1803	1.349	17	1.576	11.79	45	11.045	82.62
6	.1963	1.469	17 1/2	1.670	12.49	46	11.541	86.33
6 1/4	.2131	1.594	18	1.768	13.22	47	12.048	90.10
6 1/2	.2304	1.724	18 1/2	1.867	13.96	48	12.566	94.00

To find the capacity of pipes greater than the largest given in the table, look in the table for a pipe of one-half the given size, and multiply its capacity by 4; or one of one-third its size, and multiply its capacity by 9, etc.

To find the *weight* of water in any of the given sizes, multiply the capacity in cubic feet by 62 1/4 or the gallons by 8 1/3, or, if a closer approximation is required, by the weight of a cubic foot of water at the actual temperature in the pipe.

Given the dimensions of a cylinder in inches, to find its capacity in U. S. gallons: Square the diameter, multiply by the length and by 0.0034. If  $d$  = diameter,  $l$  = length, gallons =  $\frac{d^2 \times 0.7854 \times l}{231} = 0.0034 d^2 l$ . If  $D$  and  $L$  are in feet, gallons =  $5.875 D^2 L$ .

**CYLINDRICAL VESSELS, TANKS, CISTERNS, ETC.**

Diameter in Feet and Inches, Area in Square Feet, and U. S. Gallons Capacity for One Foot in Depth.

$$1 \text{ gallon} = 231 \text{ cubic inches} = \frac{1 \text{ cubic foot}}{7.4805} = 0.13368 \text{ cubic feet.}$$

Diam.	Area.	Gals.	Diam.	Area.	Gals.	Diam.	Area.	Gals.
Ft. In.	Sq. ft.	1 foot depth.	Ft. In.	Sq. ft.	1 foot depth.	Ft. In.	Sq. ft.	1 foot depth.
1	.785	5.87	5 8	25.22	188.66	19	283.53	2120.9
1 1	.922	6.89	5 9	25.97	194.25	19 3	291.04	2177.1
1 2	1.069	8.00	5 10	26.73	199.92	19 6	298.65	2234.0
1 3	1.227	9.18	5 11	27.49	205.67	19 9	306.35	2291.7
1 4	1.396	10.44	6	28.27	211.51	20	314.16	2350.1
1 5	1.576	11.79	6 3	30.68	229.50	20 3	322.06	2409.2
1 6	1.767	13.22	6 6	33.18	248.23	20 6	330.06	2469.1
1 7	1.969	14.73	6 9	35.78	267.69	20 9	338.16	2529.6
1 8	2.182	16.32	7	38.48	287.88	21	346.36	2591.0
1 9	2.405	17.99	7 3	41.28	308.81	21 3	354.66	2653.0
1 10	2.640	19.75	7 6	44.18	330.48	21 6	363.05	2715.8
1 11	2.885	21.58	7 9	47.17	352.88	21 9	371.54	2779.3
2	3.142	23.50	8	50.27	376.01	22	380.13	2843.6
2 1	3.409	25.50	8 3	53.46	399.88	22 3	388.82	2908.6
2 2	3.687	27.58	8 6	56.75	424.48	22 6	397.61	2974.3
2 3	3.976	29.74	8 9	60.13	449.82	22 9	406.49	3040.8
2 4	4.276	31.99	9	63.62	475.89	23	415.48	3108.0
2 5	4.587	34.31	9 3	67.20	502.70	23 3	424.56	3175.9
2 6	4.909	36.72	9 6	70.88	530.24	23 6	433.74	3244.6
2 7	5.241	39.21	9 9	74.66	558.51	23 9	443.01	3314.0
2 8	5.585	41.78	10	78.54	587.52	24	452.39	3384.1
2 9	5.940	44.43	10 3	82.52	617.26	24 3	461.86	3455.0
2 10	6.305	47.16	10 6	86.59	647.74	24 6	471.44	3526.6
2 11	6.681	49.98	10 9	90.76	678.95	24 9	481.11	3598.9
3	7.069	52.88	11	95.03	710.90	25	490.87	3672.0
3 1	7.467	55.86	11 3	99.40	743.58	25 3	500.74	3745.8
3 2	7.876	58.92	11 6	103.87	776.99	25 6	510.71	3820.3
3 3	8.296	62.06	11 9	108.43	811.14	25 9	520.77	3895.6
3 4	8.727	65.28	12	113.10	846.03	26	530.93	3971.6
3 5	9.168	68.58	12 3	117.86	881.65	26 3	541.19	4048.4
3 6	9.621	71.97	12 6	122.72	918.00	26 6	551.55	4125.9
3 7	10.085	75.44	12 9	127.68	955.09	26 9	562.00	4204.1
3 8	10.559	78.99	13	132.73	992.91	27	572.56	4283.0
3 9	11.045	82.62	13 3	137.89	1031.5	27 3	583.21	4362.7
3 10	11.541	86.33	13 6	143.14	1070.8	27 6	593.96	4443.1
3 11	12.048	90.13	13 9	148.49	1110.8	27 9	604.81	4524.3
4	12.566	94.00	14	153.94	1151.5	28	615.75	4606.2
4 1	13.095	97.96	14 3	159.48	1193.0	28 3	626.80	4688.8
4 2	13.635	102.00	14 6	165.13	1235.3	28 6	637.94	4772.1
4 3	14.186	106.12	14 9	170.87	1278.2	28 9	649.18	4856.2
4 4	14.748	110.32	15	176.71	1321.9	29	660.52	4941.0
4 5	15.321	114.61	15 3	182.65	1366.4	29 3	671.96	5026.6
4 6	15.905	118.97	15 6	188.69	1411.5	29 6	683.49	5112.9
4 7	16.500	123.42	15 9	194.83	1457.4	29 9	695.13	5199.9
4 8	17.107	127.95	16	201.06	1504.1	30	706.86	5287.7
4 9	17.726	132.56	16 3	207.39	1551.4	30 3	718.69	5376.2
4 10	18.357	137.25	16 6	213.82	1599.5	30 6	730.62	5465.4
4 11	18.999	142.02	16 9	220.35	1648.4	30 9	742.64	5555.4
5	19.653	146.88	17	226.98	1697.9	31	754.77	5646.1
5 1	20.229	151.82	17 3	233.71	1748.2	31 3	766.99	5737.5
5 2	20.917	156.83	17 6	240.53	1799.3	31 6	779.31	5829.7
5 3	21.618	161.93	17 9	247.45	1851.1	31 9	791.73	5922.6
5 4	22.331	167.12	18	254.47	1903.6	32	804.25	6016.2
5 5	23.056	172.38	18 3	261.59	1956.8	32 3	816.86	6110.6
5 6	23.793	177.72	18 6	268.80	2010.8	32 6	829.58	6205.7
5 7	24.542	183.15	18 9	276.12	2065.5	32 9	842.39	6301.5



**NUMBER OF BARRELS (31 1-2 GALLONS) IN  
CISTERNS AND TANKS.**

$$1 \text{ barrel} = 31 \frac{1}{2} \text{ gallons} = \frac{31.5 \times 231}{1728} = 4.21094 \text{ cu. ft. Reciprocal} = 0.237477$$

Depth in Feet.	Diameter in Feet.									
	5	6	7	8	9	10	11	12	13	14
1	4.663	6.714	9.139	11.937	15.108	18.652	22.569	26.859	31.522	36.557
5	23.3	33.6	45.7	59.7	75.5	93.3	112.8	134.3	157.6	182.8
6	28.0	40.3	54.8	71.6	90.6	111.9	135.4	161.2	189.1	219.3
7	32.6	47.0	64.0	83.6	105.8	130.6	158.0	188.0	220.7	255.9
8	37.3	53.7	73.1	95.5	120.9	149.2	180.6	214.9	252.2	292.5
9	42.0	60.4	82.3	107.4	136.0	167.9	203.1	241.7	283.7	329.0
10	46.6	67.1	91.4	119.4	151.1	186.5	225.7	268.6	315.2	365.6
11	51.3	73.9	100.5	131.3	166.2	205.2	248.3	295.4	346.7	402.1
12	56.0	80.6	109.7	143.2	181.3	223.8	270.8	322.3	378.3	438.7
13	60.6	87.3	118.8	155.2	196.4	242.5	293.4	349.2	409.8	475.2
14	65.3	94.0	127.9	167.1	211.5	261.1	316.0	376.0	441.3	511.8
15	69.9	100.7	137.1	179.1	226.6	279.8	338.5	402.9	472.8	548.4
16	74.6	107.4	146.2	191.0	241.7	298.4	361.1	429.7	504.4	584.9
17	79.3	114.1	155.4	202.9	256.8	317.1	383.7	456.6	535.9	621.5
18	83.9	120.9	164.5	214.9	271.9	335.7	406.2	483.5	567.4	658.0
19	88.6	127.6	173.6	226.8	287.1	354.4	428.8	510.3	598.9	694.6
20	93.3	134.3	182.8	238.7	302.2	373.0	451.4	537.2	630.4	731.1

Depth in Feet.	Diameter in Feet.							
	15	16	17	18	19	20	21	22
1	41.966	47.748	53.903	60.431	67.332	74.606	82.253	90.273
5	209.8	238.7	269.5	302.2	336.7	373.0	411.3	451.4
6	251.8	286.5	323.4	362.6	404.0	447.6	493.5	541.6
7	293.8	334.2	377.3	423.0	471.3	522.2	575.8	631.9
8	335.7	382.0	431.2	483.4	538.7	596.8	658.0	722.2
9	377.7	429.7	485.1	543.9	606.0	671.5	740.3	812.5
10	419.7	477.5	539.0	604.3	673.3	746.1	822.5	902.7
11	461.6	525.2	592.9	664.7	740.7	820.7	904.8	993.0
12	503.6	573.0	646.8	725.2	808.0	895.3	987.0	1083.3
13	545.6	620.7	700.7	785.6	875.3	969.9	1069.3	1173.5
14	587.5	668.5	754.6	846.0	942.6	1044.5	1151.5	1263.8
15	629.5	716.2	808.5	906.5	1010.0	1119.1	1233.8	1354.1
16	671.5	764.0	862.4	966.9	1077.3	1193.7	1316.0	1444.4
17	713.4	811.7	916.4	1027.3	1144.6	1268.3	1398.3	1534.5
18	755.4	859.5	970.3	1087.8	1212.0	1342.9	1480.6	1624.9
19	797.4	907.2	1024.2	1148.2	1279.3	1417.5	1562.8	1715.2
20	839.3	955.0	1078.1	1208.6	1346.6	1492.1	1645.1	1805.5



NUMBER OF BARRELS (31 1-2 GALLONS) IN CISTERNS AND TANKS. — *Continued.*

Depth in Feet.	Diameter in Feet.							
	23	24	25	26	27	28	29	30
1	98.666	107.432	116.571	126.083	135.968	146.226	156.858	167.863
5	493.3	537.2	582.9	630.4	679.8	731.1	784.3	839.3
6	592.0	644.6	699.4	756.5	815.8	877.4	941.1	1007.2
7	690.7	752.0	816.0	882.6	951.8	1023.6	1098.0	1175.0
8	789.3	859.5	932.6	1008.7	1087.7	1169.8	1254.9	1342.9
9	888.0	966.9	1049.1	1134.7	1223.7	1316.0	1411.7	1510.8
10	986.7	1074.3	1165.7	1260.8	1359.7	1462.2	1568.6	1678.6
11	1085.3	1181.8	1282.3	1386.9	1495.6	1608.5	1725.4	1846.5
12	1184.0	1289.2	1398.8	1513.0	1631.6	1754.7	1882.3	2014.4
13	1282.7	1396.6	1515.4	1639.1	1767.6	1900.9	2039.2	2182.2
14	1381.3	1504.0	1632.0	1765.2	1903.6	2047.2	2196.0	2350.1
15	1480.0	1611.5	1748.6	1891.2	2039.5	2193.4	2352.9	2517.9
16	1578.7	1718.9	1865.1	2017.3	2175.5	2339.6	2509.7	2685.8
17	1677.3	1826.3	1981.7	2143.4	2311.5	2485.8	2666.6	2853.7
18	1776.0	1933.8	2098.3	2269.5	2447.4	2632.0	2823.4	3021.5
19	1874.7	2041.2	2214.8	2395.6	2583.4	2778.3	2980.3	3189.4
20	1973.3	2148.6	2321.4	2521.7	2719.4	2924.5	3137.2	3357.3

LOGARITHMS.

**Logarithms** (abbreviation *log*). — The log of a number is the exponent of the power to which it is necessary to raise a fixed number to produce the given number. The fixed number is called the *base*. Thus if the base is 10, the log of 1000 is 3, for  $10^3 = 1000$ . There are two systems of logs in general use, the *common*, in which the base is 10, and the *Naperian*, or *hyperbolic*, in which the base is 2.718281828 . . . . The Naperian base is commonly denoted by *e*, as in the equation  $e^y = x$ , in which *y* is the Nap. log of *x*. The abbreviation  $\log_e$  is commonly used to denote the Nap log.

In any system of logs, the log of 1 is 0; the log of the base, taken in that system, is 1. In any system the base of which is greater than 1, the logs of all numbers greater than 1 are positive and the logs of all numbers less than 1 are negative.

The modulus of any system is equal to the reciprocal of the Naperian log of the base of that system. The modulus of the Naperian system is 1, that of the common system is 0.4342945.

The log of a number in any system equals the modulus of that system  $\times$  the Naperian log of the number.

The *hyperbolic* or *Naperian* log of any number equals the common  $\log \times 2.3025851$ .

Every log consists of two parts, an entire part called the *characteristic*, or *index*, and the decimal part, or *mantissa*. The mantissa only is given in the usual tables of common logs, with the decimal point omitted. The characteristic is found by a simple rule, viz., it is one less than the number of figures to the left of the decimal point in the number whose log is to be found. Thus the characteristic of numbers from 1 to 9.99 + is 0, from 10 to 99.99 + is 1, from 100 to 999 + is 2, from 0.1 to 0.99 + is - 1, from 0.01 to 0.099 + is - 2, etc. Thus

log of 2000 is 3.30103; log of 0.2 is - 1.30103, or 9.30103 - 10  
 " " 200 " 2.30103; " " 0.02 " - 2.30103, " 8.30103 - 10  
 " " 20 " 1.30103; " " 0.002 " - 3.30103, " 7.30103 - 10  
 " " 2 " 0.30103; " " 0.0002 " - 4.30103, " 6.30103 - 10

The minus sign is frequently written above the characteristic thus:  $\log 0.002 = \bar{3}.30103$ . The characteristic only is negative, the decimal part, or mantissa, being always positive.

When a log consists of a negative index and a positive mantissa, it is usual to write the negative sign over the index, or else to add 10 to the index, and to indicate the subtraction of 10 from the resulting logarithm.

Thus  $\log 0.2 = \bar{1}.30103$ , and this may be written  $9.30103 - 10$ .

In tables of logarithmic sines, etc., the  $-10$  is generally omitted, as being understood.

**Rules for use of the table of logarithms.** — To find the log of any whole number. — For 1 to 100 inclusive the log is given complete in the small table on page 137.

For 100 to 999 inclusive the decimal part of the log is given opposite the given number in the column headed 0 in the table (including the two figures to the left, making six figures). Prefix the characteristic, or index, 2.

For 1000 to 9999 inclusive: The last four figures of the log are found opposite the first three figures of the given number and in the vertical column headed with the fourth figure of the given number; prefix the two figures under column 0, and the index, which is 3.

For numbers over 10,000 having five or more digits: Find the decimal part of the log for the first four digits as above, multiply the difference figure in the last column by the remaining digit or digits, and divide by 10 if there be only one digit more, by 100 if there be two more, and so on: add the quotient to the log of the first four digits and prefix the index, which is 4 if there are five digits, 5 if there are six digits, and so on. The table of proportional parts may be used, as shown below.

To find the log of a decimal fraction or of a whole number and a decimal. — First find the log of the quantity as if there were no decimal point, then prefix the index according to rule; the index is one less than the number of figures to the left of the decimal point.

Example.  $\log$  of 3.14159.  $\log$  of 3.141 = 0.497068. Diff. = 138

From proportional parts	5 =	690
" " " "	09 =	1242

log 3.14159	0.4971494
-------------	-----------

If the number is a decimal less than unity, the index is negative and is one more than the number of zeros to the right of the decimal point.  $\log$  of 0.0682 =  $\bar{2}.833784 = 8.833784 - 10$ .

To find the number corresponding to a given log. — Find in the table the log nearest to the decimal part of the given log and take the first four digits of the required number from the column N and the top or foot of the column containing the log which is the next less than the given log. To find the 5th and 6th digits subtract the log in the table from the given log, multiply the difference by 100, and divide by the figure in the Diff. column opposite the log; annex the quotient to the four digits already found, and place the decimal point according to the rule; the number of figures to the left of the decimal point is one greater than the index. The number corresponding to a log is called the **anti-logarithm**.

Find the anti-log of.....	0.497150	
Next lowest log in table corresponds to 3141 . . . .	0.497068	Diff. = 82

Tabular diff. = 138;  $82 \div 138 = 0.59 +$

The Index being 0, the number is therefore 3.14159 +.

To multiply two numbers by the use of logarithms. — Add together the logs of the two numbers, and find the number whose log is the sum.

To divide two numbers. — Subtract the log of the divisor from the log of the dividend, and find the number whose log is the difference.

*Log of a fraction.*  $\log$  of  $a/b = \log a - \log b$ .

To raise a number to any given power. — Multiply the log of the number by the exponent of the power, and find the number whose log is the product.

To find any root of a given number. — Divide the log of the number by the index of the root. The quotient is the log of the root.

**To find the reciprocal of a number.** — Subtract the decimal part of the log of the number from 0, add 1 to the index and change the sign of the index. The result is the log of the reciprocal.

Required the reciprocal of 3.141593.

Log of 3.141593, as found above ..... 0.4971498  
 Subtract decimal part from 0 gives ..... 0.5028502

Add 1 to the index, and changing sign of the index gives . . 1.5028502 which is the log of 0.31831.

**To find the fourth term of a proportion by logarithms.** — Add the logarithms of the second and third terms, and from their sum subtract the logarithm of the first term.

When one logarithm is to be subtracted from another, it may be more convenient to convert the subtraction into an addition, which may be done by first subtracting the given logarithm from 10, adding the difference to the other logarithm, and afterwards rejecting the 10.

The difference between a given logarithm and 10 is called its *arithmetical complement*, or *cologarithm*.

To subtract one logarithm from another is the same as to add its complement and then reject 10 from the result. For  $a - b = 10 - b + a - 10$ .

To work a proportion, then, by logarithms, add the complement of the logarithm of the first term to the logarithms of the second and third terms. The characteristic must afterwards be diminished by 10.

**Example in logarithms with a negative index.** — Solve by logarithms  $\left(\frac{526}{1011}\right)^{2.45}$ , which means divide 526 by 1011 and raise the quotient to the 2.45 power.

log 526 = 2.720986  
 log 1011 = 3.004751

log of quotient = 9.716235 - 10

Multiply by 2.45

.48581175  
 3.8864940  
 19.432470

23.80477575 - (10 × 2.45) = 1.30477575 = 0.20173, Ans.

LOGARITHMS OF NUMBERS FROM 1 TO 100.

N.	Log.	N.	Log.	N.	Log.	N.	Log.	N.	Log.
1	0.000000	21	1.322219	41	1.612784	61	1.785330	81	1.908485
2	0.301030	22	1.342423	42	1.623249	62	1.792392	82	1.913814
3	0.477121	23	1.361728	43	1.633468	63	1.799341	83	1.919078
4	0.602060	24	1.380211	44	1.643453	64	1.806180	84	1.924279
5	0.698970	25	1.397940	45	1.653213	65	1.812913	85	1.929419
6	0.778151	26	1.414973	46	1.662758	66	1.819544	86	1.934498
7	0.845098	27	1.431364	47	1.672098	67	1.826075	87	1.939519
8	0.903090	28	1.447158	48	1.681241	68	1.832509	88	1.944483
9	0.954243	29	1.462398	49	1.690196	69	1.838849	89	1.949390
10	1.000000	30	1.477121	50	1.698970	70	1.845098	90	1.954243
11	1.041393	31	1.491362	51	1.707570	71	1.851258	91	1.959041
12	1.079181	32	1.505150	52	1.716003	72	1.857332	92	1.963788
13	1.113943	33	1.518514	53	1.724276	73	1.863323	93	1.968483
14	1.146128	34	1.531479	54	1.732394	74	1.869232	94	1.973128
15	1.176091	35	1.544068	55	1.740363	75	1.875061	95	1.977724
16	1.204120	36	1.556303	56	1.748188	76	1.880814	96	1.982271
17	1.230449	37	1.568202	57	1.755875	77	1.886491	97	1.986772
18	1.255273	38	1.579784	58	1.763428	78	1.892095	98	1.991226
19	1.278754	39	1.591065	59	1.770852	79	1.897627	99	1.995635
20	1.301030	40	1.602060	60	1.778151	80	1.903090	100	2.000000

No. 100 L. 000.]

[No. 109 L. 040.

N.	0	1	2	3	4	5	6	7	8	9	Diff.
100	000000	0434	0868	1301	1734	2166	2598	3029	3461	3891	432
1	4321	4751	5181	5609	6038	6466	6894	7321	7748	8174	428
2	8600	9026	9451	9876							
					0300	0724	1147	1570	1993	2415	424
3	012837	3259	3680	4100	4521	4940	5360	5779	6197	6616	420
4	7033	7451	7868	8284	8700	9116	9532	9947			
									0361	0775	416
5	021189	1603	2016	2428	2841	3252	3664	4075	4486	4896	412
6	5306	5715	6125	6533	6942	7350	7757	8164	8571	8978	408
7	9384	9789									
			0195	0600	1004	1408	1812	2216	2619	3021	404
8	033424	3826	4227	4628	5029	5430	5830	6230	6629	7028	400
9	7426	7825	8223	8620	9017	9414	9811				
	04							0207	0602	0998	397

PROPORTIONAL PARTS.

Diff.	1	2	3	4	5	6	7	8	9
434	43.4	86.8	130.2	173.6	217.0	260.4	303.8	347.2	390.6
433	43.3	86.6	129.9	173.2	216.5	259.8	303.1	346.4	389.7
432	43.2	86.4	129.6	172.8	216.0	259.2	302.4	345.6	388.8
431	43.1	86.2	129.3	172.4	215.5	258.6	301.7	344.8	387.9
430	43.0	86.0	129.0	172.0	215.0	258.0	301.0	344.0	387.0
429	42.9	85.8	128.7	171.6	214.5	257.4	300.3	343.2	386.1
428	42.8	85.6	128.4	171.2	214.0	256.8	299.6	342.4	385.2
427	42.7	85.4	128.1	170.8	213.5	256.2	298.9	341.6	384.3
426	42.6	85.2	127.8	170.4	213.0	255.6	298.2	340.8	383.4
425	42.5	85.0	127.5	170.0	212.5	255.0	297.5	340.0	382.5
424	42.4	84.8	127.2	169.6	212.0	254.4	296.8	339.2	381.6
423	42.3	84.6	126.9	169.2	211.5	253.8	296.1	338.4	380.7
422	42.2	84.4	126.6	168.8	211.0	253.2	295.4	337.6	379.8
421	42.1	84.2	126.3	168.4	210.5	252.6	294.7	336.8	378.9
420	42.0	84.0	126.0	168.0	210.0	252.0	294.0	336.0	378.0
419	41.9	83.8	125.7	167.6	209.5	251.4	293.3	335.2	377.1
418	41.8	83.6	125.4	167.2	209.0	250.8	292.6	334.4	376.2
417	41.7	83.4	125.1	166.8	208.5	250.2	291.9	333.6	375.3
416	41.6	83.2	124.8	166.4	208.0	249.6	291.2	332.8	374.4
415	41.5	83.0	124.5	166.0	207.5	249.0	290.5	332.0	373.5
414	41.4	82.8	124.2	165.6	207.0	248.4	289.8	331.2	372.6
413	41.3	82.6	123.9	165.2	206.5	247.8	289.1	330.4	371.7
412	41.2	82.4	123.6	164.8	206.0	247.2	288.4	329.6	370.8
411	41.1	82.2	123.3	164.4	205.5	246.6	287.7	328.8	369.9
410	41.0	82.0	123.0	164.0	205.0	246.0	287.0	328.0	369.0
409	40.9	81.8	122.7	163.6	204.5	245.4	286.3	327.2	368.1
408	40.8	81.6	122.4	163.2	204.0	244.8	285.6	326.4	367.2
407	40.7	81.4	122.1	162.8	203.5	244.2	284.9	325.6	366.3
406	40.6	81.2	121.8	162.4	203.0	243.6	284.2	324.8	365.4
405	40.5	81.0	121.5	162.0	202.5	243.0	283.5	324.0	364.5
404	40.4	80.8	121.2	161.6	202.0	242.4	282.8	323.2	363.6
403	40.3	80.6	120.9	161.2	201.5	241.8	282.1	322.4	362.7
402	40.2	80.4	120.6	160.8	201.0	241.2	281.4	321.6	361.8
401	40.1	80.2	120.3	160.4	200.5	240.6	280.7	320.8	360.9
400	40.0	80.0	120.0	160.0	200.0	240.0	280.0	320.0	360.0
399	39.9	79.8	119.7	159.6	199.5	239.4	279.3	319.2	359.1
398	39.8	79.6	119.4	159.2	199.0	238.8	278.6	318.4	358.2
397	39.7	79.4	119.1	158.8	198.5	238.2	277.9	317.6	357.3
396	39.6	79.2	118.8	158.4	198.0	237.6	277.2	316.8	356.4
395	39.5	79.0	118.5	158.0	197.5	237.0	276.5	316.0	355.5



No. 110 L. 041.]

[No. 119 L. 078

N.	0	1	2	3	4	5	6	7	8	9	Diff.
110	041393	1787	2182	2576	2969	3362	3755	4148	4540	4932	393
1	5323	5714	6105	6495	6885	7275	7664	8053	8442	8830	390
2	9218	9606	9993								
3	053078	3463	3846	4230	4613	4996	5378	5760	6142	6524	386
4	6905	7286	7666	8046	8426	8805	9185	9563	9942		383
5	060693	1075	1452	1829	2206	2582	2958	3333	3709	4083	379
6	4458	4832	5206	5580	5953	6326	6699	7071	7443	7815	376
7	8186	8557	8928	9298	9668						373
8	071882	2250	2617	2935	3352	3718	4085	4451	4816	5182	370
9	5547	5912	6276	6640	7004	7368	7731	8094	8457	8819	366
											363

PROPORTIONAL PARTS.

Diff.	1	2	3	4	5	6	7	8	9
395	39.5	79.0	118.5	158.0	197.5	237.0	276.5	316.0	355.5
394	39.4	78.8	118.2	157.6	197.0	236.4	275.8	315.2	354.6
393	39.3	78.6	117.9	157.2	196.5	235.8	275.1	314.4	353.7
392	39.2	78.4	117.6	156.8	196.0	235.2	274.4	313.6	352.8
391	39.1	78.2	117.3	156.4	195.5	234.6	273.7	312.8	351.9
390	39.0	78.0	117.0	156.0	195.0	234.0	273.0	312.0	351.0
389	38.9	77.8	116.7	155.6	194.5	233.4	272.3	311.2	350.1
388	38.8	77.6	116.4	155.2	194.0	232.8	271.6	310.4	349.2
387	38.7	77.4	116.1	154.8	193.5	232.2	270.9	309.6	348.3
386	38.6	77.2	115.8	154.4	193.0	231.6	270.2	308.8	347.4
385	38.5	77.0	115.5	154.0	192.5	231.0	269.5	308.0	346.5
384	38.4	76.8	115.2	153.6	192.0	230.4	268.8	307.2	345.6
383	38.3	76.6	114.9	153.2	191.5	229.8	268.1	306.4	344.7
382	38.2	76.4	114.6	152.8	191.0	229.2	267.4	305.6	343.8
381	38.1	76.2	114.3	152.4	190.5	228.6	266.7	304.8	342.9
380	38.0	76.0	114.0	152.0	190.0	228.0	266.0	304.0	342.0
379	37.9	75.8	113.7	151.6	189.5	227.4	265.3	303.2	341.1
378	37.8	75.6	113.4	151.2	189.0	226.8	264.6	302.4	340.2
377	37.7	75.4	113.1	150.8	188.5	226.2	263.9	301.6	339.3
376	37.6	75.2	112.8	150.4	188.0	225.6	263.2	300.8	338.4
375	37.5	75.0	112.5	150.0	187.5	225.0	262.5	300.0	337.5
374	37.4	74.8	112.2	149.6	187.0	224.4	261.8	299.2	336.6
373	37.3	74.6	111.9	149.2	186.5	223.8	261.1	298.4	335.7
372	37.2	74.4	111.6	148.8	186.0	223.2	260.4	297.6	334.8
371	37.1	74.2	111.3	148.4	185.5	222.6	259.7	296.8	333.9
370	37.0	74.0	111.0	148.0	185.0	222.0	259.0	296.0	333.0
369	36.9	73.8	110.7	147.6	184.5	221.4	258.3	295.2	332.1
368	36.8	73.6	110.4	147.2	184.0	220.8	257.6	294.4	331.2
367	36.7	73.4	110.1	146.8	183.5	220.2	256.9	293.6	330.3
366	36.6	73.2	109.8	146.4	183.0	219.6	256.2	292.8	329.4
365	36.5	73.0	109.5	146.0	182.5	219.0	255.5	292.0	328.5
364	36.4	72.8	109.2	145.6	182.0	218.4	254.8	291.2	327.6
363	36.3	72.6	108.9	145.2	181.5	217.8	254.1	290.4	326.7
362	36.2	72.4	108.6	144.8	181.0	217.2	253.4	289.6	325.8
361	36.1	72.2	108.3	144.4	180.5	216.6	252.7	288.8	324.9
360	36.0	72.0	108.0	144.0	180.0	216.0	252.0	288.0	324.0
359	35.9	71.8	107.7	143.6	179.5	215.4	251.3	287.2	323.1
358	35.8	71.6	107.4	143.2	179.0	214.8	250.6	286.4	322.2
357	35.7	71.4	107.1	142.8	178.5	214.2	249.9	285.6	321.3
356	35.6	71.2	106.8	142.4	178.0	213.6	249.2	284.8	320.4

No. 120 L. 079.]

[No. 134 L. 130.

N.	0	1	2	3	4	5	6	7	8	9	Diff.
120	079181	9543	9904								
1	082785	3144	3503	0266	0626	0987	1347	1707	2067	2426	360
2	6360	6716	7071	3861	4219	4576	4934	5291	5647	6004	357
3	9905			7426	7781	8136	8490	8845	9198	9552	355
4	093422	0258	0611	0963	1315	1667	2018	2370	2721	3071	352
5	6910	3772	4122	4471	4820	5169	5518	5866	6215	6562	349
6	100371	0715	1059	1403	1747	2091	2434	2777	3119	0026	346
7	3804	4146	4487	4828	5169	5510	5851	6191	6531	3462	343
8	7210	7549	7888	8227	8565	8903	9241	9579	9916	6871	341
9	110590	0926	1263	1599	1934	2270	2605	2940	3275	0253	338
130	3943	4277	4611	4944	5278	5611	5943	6276	6608	3609	335
1	7271	7603	7934	8265	8595	8926	9256	9586	9915	6940	333
2	120574	0903	1231	1560	1888	2216	2544	2871	3198	0245	330
3	3852	4178	4504	4830	5156	5481	5806	6131	6456	3525	328
4	7105	7429	7753	8076	8399	8722	9045	9368	9690	6781	325
13										0012	323

PROPORTIONAL PARTS.

Diff.	1	2	3	4	5	6	7	8	9
355	35.5	71.0	106.5	142.0	177.5	213.0	248.5	284.0	319.5
354	35.4	70.8	106.2	141.6	177.0	212.4	247.8	283.2	318.6
353	35.3	70.6	105.9	141.2	176.5	211.8	247.1	282.4	317.7
352	35.2	70.4	105.6	140.8	176.0	211.2	246.4	281.6	316.8
351	35.1	70.2	105.3	140.4	175.5	210.6	245.7	280.8	315.9
350	35.0	70.0	105.0	140.0	175.0	210.0	245.0	280.0	315.0
349	34.9	69.8	104.7	139.6	174.5	209.4	244.3	279.2	314.1
348	34.8	69.6	104.4	139.2	174.0	208.8	243.6	278.4	313.2
347	34.7	69.4	104.1	138.8	173.5	208.2	242.9	277.6	312.3
346	34.6	69.2	103.8	138.4	173.0	207.6	242.2	276.8	311.4
345	34.5	69.0	103.5	138.0	172.5	207.0	241.5	276.0	310.5
344	34.4	68.8	103.2	137.6	172.0	206.4	240.8	275.2	309.6
343	34.3	68.6	102.9	137.2	171.5	205.8	240.1	274.4	308.7
342	34.2	68.4	102.6	136.8	171.0	205.2	239.4	273.6	307.8
341	34.1	68.2	102.3	136.4	170.5	204.6	238.7	272.8	306.9
340	34.0	68.0	102.0	136.0	170.0	204.0	238.0	272.0	306.0
339	33.9	67.8	101.7	135.6	169.5	203.4	237.3	271.2	305.1
338	33.8	67.6	101.4	135.2	169.0	202.8	236.6	270.4	304.2
337	33.7	67.4	101.1	134.8	168.5	202.2	235.9	269.6	303.3
336	33.6	67.2	100.8	134.4	168.0	201.6	235.2	268.8	302.4
335	33.5	67.0	100.5	134.0	167.5	201.0	234.5	268.0	301.5
334	33.4	66.8	100.2	133.6	167.0	200.4	233.8	267.2	300.6
333	33.3	66.6	99.9	133.2	166.5	199.8	233.1	266.4	299.7
332	33.2	66.4	99.6	132.8	166.0	199.2	232.4	265.6	298.8
331	33.1	66.2	99.3	132.4	165.5	198.6	231.7	264.8	297.9
330	33.0	66.0	99.0	132.0	165.0	198.0	231.0	264.0	297.0
329	32.9	65.8	98.7	131.6	164.5	197.4	230.3	263.2	296.1
328	32.8	65.6	98.4	131.2	164.0	196.8	229.6	262.4	295.2
327	32.7	65.4	98.1	130.8	163.5	196.2	228.9	261.6	294.3
326	32.6	65.2	97.8	130.4	163.0	195.6	228.2	260.8	293.4
325	32.5	65.0	97.5	130.0	162.5	195.0	227.5	260.0	292.5
324	32.4	64.8	97.2	129.6	162.0	194.4	226.8	259.2	291.6
323	32.3	64.6	96.9	129.2	161.5	193.8	226.1	258.4	290.7
322	32.2	64.4	96.6	128.8	161.0	193.2	225.4	257.6	289.8

No. 135 L. 130.]

[No. 149 L. 175.

N.	0	1	2	3	4	5	6	7	8	9	Diff.
135	130334	0655	0977	1298	1619	1939	2260	2580	2900	3219	321
6	3539	3858	4177	4496	4814	5133	5451	5769	6086	6403	318
7	6721	7037	7354	7671	7987	8303	8618	8934	9249	9564	316
8	9879										
9	143015	0194	0508	0822	1136	1450	1763	2076	2389	2702	314
		3327	3639	3951	4263	4574	4885	5196	5507	5818	311
140	6128	6438	6748	7058	7367	7676	7985	8294	8603	8911	309
1	9219	9527	9835								
2	152288	2594	2900	0142	0449	0756	1063	1370	1676	1982	307
3	5336	5640	5943	3205	3510	3815	4120	4424	4728	5032	305
4	8362	8664	8965	6246	6549	6852	7154	7457	7759	8061	303
5	161368	1667	1967	2266	2564	2863	3161	0168	0469	0769	301
6	4353	4650	4947	5244	5541	5838	6134	3460	3758	4055	299
7	7317	7613	7908	8203	8497	8792	9086	6430	6726	7022	297
8	170262	0555	0848	1141	1434	1726	2019	2311	2603	2895	293
9	3186	3478	3769	4060	4351	4641	4932	5222	5512	5802	291

PROPORTIONAL PARTS.

Diff.	1	2	3	4	5	6	7	8	9
321	32.1	64.2	96.3	128.4	160.5	192.6	224.7	256.8	288.9
320	32.0	64.0	96.0	128.0	160.0	192.0	224.0	256.0	288.0
319	31.9	63.8	95.7	127.6	159.5	191.4	223.3	255.2	287.1
318	31.8	63.6	95.4	127.2	159.0	190.8	222.6	254.4	286.2
317	31.7	63.4	95.1	126.8	158.5	190.2	221.9	253.6	285.3
316	31.6	63.2	94.8	126.4	158.0	189.6	221.2	252.8	284.4
315	31.5	63.0	94.5	126.0	157.5	189.0	220.5	252.0	283.5
314	31.4	62.8	94.2	125.6	157.0	188.4	219.8	251.2	282.6
313	31.3	62.6	93.9	125.2	156.5	187.8	219.1	250.4	281.7
312	31.2	62.4	93.6	124.8	156.0	187.2	218.4	249.6	280.8
311	31.1	62.2	93.3	124.4	155.5	186.6	217.7	248.8	279.9
310	31.0	62.0	93.0	124.0	155.0	186.0	217.0	248.0	279.0
309	30.9	61.8	92.7	123.6	154.5	185.4	216.3	247.2	278.1
308	30.8	61.6	92.4	123.2	154.0	184.8	215.6	246.4	277.2
307	30.7	61.4	92.1	122.8	153.5	184.2	214.9	245.6	276.3
306	30.6	61.2	91.8	122.4	153.0	183.6	214.2	244.8	275.4
305	30.5	61.0	91.5	122.0	152.5	183.0	213.5	244.0	274.5
304	30.4	60.8	91.2	121.6	152.0	182.4	212.8	243.2	273.6
303	30.3	60.6	90.9	121.2	151.5	181.8	212.1	242.4	272.7
302	30.2	60.4	90.6	120.8	151.0	181.2	211.4	241.6	271.8
301	30.1	60.2	90.3	120.4	150.5	180.6	210.7	240.8	270.9
300	30.0	60.0	90.0	120.0	150.0	180.0	210.0	240.0	270.0
299	29.9	59.8	89.7	119.6	149.5	179.4	209.3	239.2	269.1
298	29.8	59.6	89.4	119.2	149.0	178.8	208.6	238.4	268.2
297	29.7	59.4	89.1	118.8	148.5	178.2	207.9	237.6	267.3
296	29.6	59.2	88.8	118.4	148.0	177.6	207.2	236.8	266.4
295	29.5	59.0	88.5	118.0	147.5	177.0	206.5	236.0	265.5
294	29.4	58.8	88.2	117.6	147.0	176.4	205.8	235.2	264.6
293	29.3	58.6	87.9	117.2	146.5	175.8	205.1	234.4	263.7
292	29.2	58.4	87.6	116.8	146.0	175.2	204.4	233.6	262.8
291	29.1	58.2	87.3	116.4	145.5	174.6	203.7	232.8	261.9
290	29.0	58.0	87.0	116.0	145.0	174.0	203.0	232.0	261.0
289	28.9	57.8	86.7	115.6	144.5	173.4	202.3	231.2	260.1
288	28.8	57.6	86.4	115.2	144.0	172.8	201.6	230.4	259.2
287	28.7	57.4	86.1	114.8	143.5	172.2	200.9	229.6	258.3
286	28.6	57.2	85.8	114.4	143.0	171.6	200.2	228.8	257.4

No. 150 L. 176.]

[No. 169 L. 230

N.	0	1	2	3	4	5	6	7	8	9	Diff.
150	176091	6381	6670	6959	7248	7536	7825	8113	8401	8689	289
1	8977	9264	9552	9839							
2	181844	2129	2415	2700	0126	0413	0699	0986	1272	1558	287
3	4691	4975	5259	5542	5825	6108	6391	6674	6956	7239	285
4	7521	7803	8034	8366	8647	8928	9209	9490	9771		283
5	190332	0612	0892	1171	1451	1730	2010	2289	2567	0051	281
6	3125	3403	3681	3959	4237	4514	4792	5069	5346	5623	279
7	5900	6176	6453	6729	7005	7281	7556	7832	8107	8382	278
8	8657	8932	9206	9481	9755						276
9	201397	1670	1943	2216	2488	2761	3033	3305	3577	3848	274
160											272
1	4120	4391	4663	4934	5204	5475	5746	6016	6286	6556	271
2	6826	7096	7365	7634	7904	8173	8441	8710	8979	9247	269
3	212188	2454	2720	2986	3252	3518	3783	4049	4314	4579	267
4	4844	5109	5373	5638	5902	6166	6430	6694	6957	7221	266
5	7434	7747	8010	8273	8536	8798	9060	9323	9585	9846	264
6	220108	0370	0631	0892	1153	1414	1675	1936	2196	2456	262
7	2716	2976	3236	3496	3755	4015	4274	4533	4792	5051	261
8	5309	5568	5826	6084	6342	6600	6858	7115	7372	7630	259
9	7887	8144	8400	8657	8913	9170	9426	9682	9938		258
23										0193	256

## PROPORTIONAL PARTS.

Diff.	1	2	3	4	5	6	7	8	9
285	28.5	57.0	85.5	114.0	142.5	171.0	199.5	228.0	256.5
284	28.4	56.8	85.2	113.6	142.0	170.4	198.8	227.2	255.6
283	28.3	56.6	84.9	113.2	141.5	169.8	198.1	226.4	254.7
282	28.2	56.4	84.6	112.8	141.0	169.2	197.4	225.6	253.8
281	28.1	56.2	84.3	112.4	140.5	168.6	196.7	224.8	252.9
280	28.0	56.0	84.0	112.0	140.0	168.0	196.0	224.0	252.0
279	27.9	55.8	83.7	111.6	139.5	167.4	195.3	223.2	251.1
278	27.8	55.6	83.4	111.2	139.0	166.8	194.6	222.4	250.2
277	27.7	55.4	83.1	110.8	138.5	166.2	193.9	221.6	249.3
276	27.6	55.2	82.8	110.4	138.0	165.6	193.2	220.8	248.4
275	27.5	55.0	82.5	110.0	137.5	165.0	192.5	220.0	247.5
274	27.4	54.8	82.2	109.6	137.0	164.4	191.8	219.2	246.6
273	27.3	54.6	81.9	109.2	136.5	163.8	191.1	218.4	245.7
272	27.2	54.4	81.6	108.8	136.0	163.2	190.4	217.6	244.8
271	27.1	54.2	81.3	108.4	135.5	162.6	189.7	216.8	243.9
270	27.0	54.0	81.0	108.0	135.0	162.0	189.0	216.0	243.0
269	26.9	53.8	80.7	107.6	134.5	161.4	188.3	215.2	242.1
268	26.8	53.6	80.4	107.2	134.0	160.8	187.6	214.4	241.2
267	26.7	53.4	80.1	106.8	133.5	160.2	186.9	213.6	240.3
266	26.6	53.2	79.8	106.4	133.0	159.6	186.2	212.8	239.4
265	26.5	53.0	79.5	106.0	132.5	159.0	185.5	212.0	238.5
264	26.4	52.8	79.2	105.6	132.0	158.4	184.8	211.2	237.6
263	26.3	52.6	78.9	105.2	131.5	157.8	184.1	210.4	236.7
262	26.2	52.4	78.6	104.8	131.0	157.2	183.4	209.6	235.8
261	26.1	52.2	78.3	104.4	130.5	156.6	182.7	208.8	234.9
260	26.0	52.0	78.0	104.0	130.0	156.0	182.0	208.0	234.0
259	25.9	51.8	77.7	103.6	129.5	155.4	181.3	207.2	233.1
258	25.8	51.6	77.4	103.2	129.0	154.8	180.6	206.4	232.2
257	25.7	51.4	77.1	102.8	128.5	154.2	179.9	205.6	231.3
256	25.6	51.2	76.8	102.4	128.0	153.6	179.2	204.8	230.4
255	25.5	51.0	76.5	102.0	127.5	153.0	178.5	204.0	229.5



No. 170 L. 230.]

[No. 189 L. 278.

N.	0	1	2	3	4	5	6	7	8	9	Diff.
170	230449	0704	0960	1215	1470	1724	1979	2234	2488	2742	255
1	2996	3250	3504	3757	4011	4264	4517	4770	5023	5276	253
2	5528	5781	6033	6285	6537	6789	7041	7292	7544	7795	252
3	8046	8297	8548	8799	9049	9299	9550	9800			
4	240549	0799	1048	1297	1546	1795	2044	2293	0050	0300	250
5	3038	3286	3534	3782	4030	4277	4525	4772	2541	2790	249
6	5513	5759	6006	6252	6499	6745	6991	7237	5019	5266	248
7	7973	8219	8464	8709	8954	9198	9443	9687	7482	7728	246
8									0176		245
9	250420	0664	0908	1151	1395	1638	1881	2125	2368	2610	243
180	2853	3096	3338	3580	3822	4064	4306	4548	4790	5031	242
1	5273	5514	5755	5996	6237	6477	6718	6958	7198	7439	241
2	7679	7918	8158	8398	8637	8877	9116	9355	9594	9833	239
3	260071	0310	0548	0787	1025	1263	1501	1739	1976	2214	238
4	2451	2688	2925	3162	3399	3636	3873	4109	4346	4582	237
5	4818	5054	5290	5525	5761	5996	6232	6467	6702	6937	235
6	7172	7406	7641	7875	8110	8344	8578	8812	9046	9279	234
7	9513	9746	9980								
8				0213	0446	0679	0912	1144	1377	1609	233
9	271842	2074	2306	2538	2770	3001	3233	3464	3696	3927	232
	4158	4389	4620	4850	5081	5311	5542	5772	6002	6232	230
	6462	6692	6921	7151	7380	7609	7838	8067	8296	8525	229

PROPORTIONAL PARTS.

Diff.	1	2	3	4	5	6	7	8	9
255	25.5	51.0	76.5	102.0	127.5	153.0	178.5	204.0	229.5
254	25.4	50.8	76.2	101.6	127.0	152.4	177.8	203.2	228.6
253	25.3	50.6	75.9	101.2	126.5	151.8	177.1	202.4	227.7
252	25.2	50.4	75.6	100.8	126.0	151.2	176.4	201.6	226.8
251	25.1	50.2	75.3	100.4	125.5	150.6	175.7	200.8	225.9
250	25.0	50.0	75.0	100.0	125.0	150.0	175.0	200.0	225.0
249	24.9	49.8	74.7	99.6	124.5	149.4	174.3	199.2	224.1
248	24.8	49.6	74.4	99.2	124.0	148.8	173.6	198.4	223.2
247	24.7	49.4	74.1	98.8	123.5	148.2	172.9	197.6	222.3
246	24.6	49.2	73.8	98.4	123.0	147.6	172.2	196.8	221.4
245	24.5	49.0	73.5	98.0	122.5	147.0	171.5	196.0	220.5
244	24.4	48.8	73.2	97.6	122.0	146.4	170.8	195.2	219.6
243	24.3	48.6	72.9	97.2	121.5	145.8	170.1	194.4	218.7
242	24.2	48.4	72.6	96.8	121.0	145.2	169.4	193.6	217.8
241	24.1	48.2	72.3	96.4	120.5	144.6	168.7	192.8	216.9
240	24.0	48.0	72.0	96.0	120.0	144.0	168.0	192.0	216.0
239	23.9	47.8	71.7	95.6	119.5	143.4	167.3	191.2	215.1
238	23.8	47.6	71.4	95.2	119.0	142.8	166.6	190.4	214.2
237	23.7	47.4	71.1	94.8	118.5	142.2	165.9	189.6	213.3
236	23.6	47.2	70.8	94.4	118.0	141.6	165.2	188.8	212.4
235	23.5	47.0	70.5	94.0	117.5	141.0	164.5	188.0	211.5
234	23.4	46.8	70.2	93.6	117.0	140.4	163.8	187.2	210.6
233	23.3	46.6	69.9	93.2	116.5	139.8	163.1	186.4	209.7
232	23.2	46.4	69.6	92.8	116.0	139.2	162.4	185.6	208.8
231	23.1	46.2	69.3	92.4	115.5	138.6	161.7	184.8	207.9
230	23.0	46.0	69.0	92.0	115.0	138.0	161.0	184.0	207.0
229	22.9	45.8	68.7	91.6	114.5	137.4	160.3	183.2	206.1
228	22.8	45.6	68.4	91.2	114.0	136.8	159.6	182.4	205.2
227	22.7	45.4	68.1	90.8	113.5	136.2	158.9	181.6	204.3
226	22.6	45.2	67.8	90.4	113.0	135.6	158.2	180.8	203.4

No. 190 L. 278.]

[No. 214 L. 332.

N.	0	1	2	3	4	5	6	7	8	9	Diff.
190	278754	8982	9211	9439	9667	9895					
1	281033	1261	1488	1715	1942	2169	0123	0351	0578	0806	228
2	3301	3527	3753	3979	4205	4431	2396	2622	2849	3075	227
3	5557	5782	6007	6232	6456	6681	4656	4882	5107	5332	226
4	7802	8026	8249	8473	8696	8920	6905	7130	7354	7578	225
5	290035	0257	0480	0702	0925	1147	9143	9366	9589	9812	223
6	2256	2478	2699	2920	3141	3363	1369	1591	1813	2034	222
7	4466	4687	4907	5127	5347	5567	3584	3804	4025	4246	221
8	6665	6884	7104	7323	7542	7761	5787	6007	6226	6446	220
9	8853	9071	9289	9507	9725	9943	7979	8198	8416	8635	219
							0161	0378	0595	0813	218
200	301030	1247	1464	1681	1898	2114	2331	2547	2764	2980	217
1	3196	3412	3628	3844	4059	4275	4491	4706	4921	5136	216
2	5351	5566	5781	5996	6211	6425	6639	6854	7068	7282	215
3	7496	7710	7924	8137	8351	8564	8778	8991	9204	9417	213
4	9630	9843									
5	311754	1966	0056	0268	0481	0693	0906	1118	1330	1542	212
6	3867	4078	2177	2389	2600	2812	3023	3234	3445	3656	211
7	5970	6180	4289	4499	4710	4920	5130	5340	5551	5760	210
8	8063	8272	6390	6599	6809	7018	7227	7436	7646	7854	209
9	320146	0354	8481	8689	8898	9106	9314	9522	9730	9938	208
			0562	0769	0977	1184	1391	1598	1805	2012	207
210	2219	2426	2633	2839	3046	3252	3458	3665	3871	4077	206
1	4282	4488	4694	4899	5105	5310	5516	5721	5926	6131	205
2	6336	6541	6745	6950	7155	7359	7563	7767	7972	8176	204
3	8380	8583	8787	8991	9194	9398	9601	9805			
4	330414	0617	0819	1022	1225	1427	1630	1832	0008	0211	203
									2034	2236	202

PROPORTIONAL PARTS.

Diff.	1	2	3	4	5	6	7	8	9
225	22.5	45.0	67.5	90.0	112.5	135.0	157.5	180.0	202.5
224	22.4	44.8	67.2	89.6	112.0	134.4	156.8	179.2	201.6
223	22.3	44.6	66.9	89.2	111.5	133.8	156.1	178.4	200.7
222	22.2	44.4	66.6	88.8	111.0	133.2	155.4	177.6	199.8
221	22.1	44.2	66.3	88.4	110.5	132.6	154.7	176.8	198.9
220	22.0	44.0	66.0	88.0	110.0	132.0	154.0	176.0	198.0
219	21.9	43.8	65.7	87.6	109.5	131.4	153.3	175.2	197.1
218	21.8	43.6	65.4	87.2	109.0	130.8	152.6	174.4	196.2
217	21.7	43.4	65.1	86.8	108.5	130.2	151.9	173.6	195.3
216	21.6	43.2	64.8	86.4	108.0	129.6	151.2	172.8	194.4
215	21.5	43.0	64.5	86.0	107.5	129.0	150.5	172.0	193.5
214	21.4	42.8	64.2	85.6	107.0	128.4	149.8	171.2	192.6
213	21.3	42.6	63.9	85.2	106.5	127.8	149.1	170.4	191.7
212	21.2	42.4	63.6	84.8	106.0	127.2	148.4	169.6	190.8
211	21.1	42.2	63.3	84.4	105.5	126.6	147.7	168.8	189.9
210	21.0	42.0	63.0	84.0	105.0	126.0	147.0	168.0	189.0
209	20.9	41.8	62.7	83.6	104.5	125.4	146.3	167.2	188.1
208	20.8	41.6	62.4	83.2	104.0	124.8	145.6	166.4	187.2
207	20.7	41.4	62.1	82.8	103.5	124.2	144.9	165.6	186.3
206	20.6	41.2	61.8	82.4	103.0	123.6	144.2	164.8	185.4
205	20.5	41.0	61.5	82.0	102.5	123.0	143.5	164.0	184.5
204	20.4	40.8	61.2	81.6	102.0	122.4	142.8	163.2	183.6
203	20.3	40.6	60.9	81.2	101.5	121.8	142.1	162.4	182.7
202	20.2	40.4	60.6	80.8	101.0	121.2	141.4	161.6	181.8

No. 215 L. 332.]

[No. 239 L. 380.

N.	0	1	2	3	4	5	6	7	8	9	Diff.
215	332438	2640	2842	3044	3246	3447	3649	3850	4051	4253	202
6	4454	4655	4856	5057	5257	5458	5658	5859	6059	6260	201
7	6460	6660	6860	7060	7260	7459	7659	7858	8058	8257	200
8	8456	8656	8855	9054	9253	9451	9650	9849			
9	340444	0642	0841	1039	1237	1435	1632	1830	0047	0246	199
									2028	2225	198
220	2423	2620	2817	3014	3212	3409	3606	3802	3999	4196	197
1	4392	4589	4785	4981	5178	5374	5570	5766	5962	6157	196
2	6353	6549	6744	6939	7135	7330	7525	7720	7915	8110	195
3	8305	8500	8694	8889	9083	9278	9472	9666	9860		
4	350248	0442	0636	0829	1023	1216	1410	1603	1796	1989	194
5	2183	2375	2568	2761	2954	3147	3339	3532	3724	3916	193
6	4108	4301	4493	4685	4876	5068	5260	5452	5643	5834	192
7	6026	6217	6408	6599	6790	6981	7172	7363	7554	7744	191
8	7935	8125	8316	8506	8696	8886	9076	9266	9456	9646	190
9	9835										
		0025	0215	0404	0593	0783	0972	1161	1350	1539	189
230	361728	1917	2105	2294	2482	2671	2859	3048	3236	3424	188
1	3612	3800	3988	4176	4363	4551	4739	4926	5113	5301	188
2	5488	5675	5862	6049	6236	6423	6610	6796	6983	7169	187
3	7356	7542	7729	7915	8101	8287	8473	8659	8845	9030	186
4	9216	9401	9587	9772	9958						
						0143	0328	0513	0698	0883	185
5	371068	1253	1437	1622	1806	1991	2175	2360	2544	2728	184
6	2912	3096	3280	3464	3647	3831	4015	4198	4382	4565	184
7	4748	4932	5115	5298	5481	5664	5846	6029	6212	6394	183
8	6577	6759	6942	7124	7306	7488	7670	7852	8034	8216	182
9	8398	8580	8761	8943	9124	9306	9487	9668	9849		
	38									0030	181

PROPORTIONAL PARTS.

Diff.	1	2	3	4	5	6	7	8	9
202	20.2	40.4	60.6	80.8	101.0	121.2	141.4	161.6	181.8
201	20.1	40.2	60.3	80.4	100.5	120.6	140.7	160.8	180.9
200	20.0	40.0	60.0	80.0	100.0	120.0	140.0	160.0	180.0
199	19.9	39.8	59.7	79.6	99.5	119.4	139.3	159.2	179.1
198	19.8	39.6	59.4	79.2	99.0	118.8	138.6	158.4	178.2
197	19.7	39.4	59.1	78.8	98.5	118.2	137.9	157.6	177.3
196	19.6	39.2	58.8	78.4	98.0	117.6	137.2	156.8	176.4
195	19.5	39.0	58.5	78.0	97.5	117.0	136.5	156.0	175.5
194	19.4	38.8	58.2	77.6	97.0	116.4	135.8	155.2	174.6
193	19.3	38.6	57.9	77.2	96.5	115.8	135.1	154.4	173.7
192	19.2	38.4	57.6	76.8	96.0	115.2	134.4	153.6	172.8
191	19.1	38.2	57.3	76.4	95.5	114.6	133.7	152.8	171.9
190	19.0	38.0	57.0	76.0	95.0	114.0	133.0	152.0	171.0
189	18.9	37.8	56.7	75.6	94.5	113.4	132.3	151.2	170.1
188	18.8	37.6	56.4	75.2	94.0	112.8	131.6	150.4	169.2
187	18.7	37.4	56.1	74.8	93.5	112.2	130.9	149.6	168.3
186	18.6	37.2	55.8	74.4	93.0	111.6	130.2	148.8	167.4
185	18.5	37.0	55.5	74.0	92.5	111.0	129.5	148.0	166.5
184	18.4	36.8	55.2	73.6	92.0	110.4	128.8	147.2	165.6
183	18.3	36.6	54.9	73.2	91.5	109.8	128.1	146.4	164.7
182	18.2	36.4	54.6	72.8	91.0	109.2	127.4	145.6	163.8
181	18.1	36.2	54.3	72.4	90.5	108.6	126.7	144.8	162.9
180	18.0	36.0	54.0	72.0	90.0	108.0	126.0	144.0	162.0
179	17.9	35.8	53.7	71.6	89.5	107.4	125.3	143.2	161.1

No. 240 L. 380.]

[No. 269 L. 431

N.	0	1	2	3	4	5	6	7	8	9	Diff.
240	380211	0392	0573	0754	0934	1115	1296	1476	1656	1837	181
1	2017	2197	2377	2557	2737	2917	3097	3277	3456	3636	180
2	3815	3995	4174	4353	4533	4712	4891	5070	5249	5428	179
3	5606	5785	5964	6142	6321	6499	6677	6856	7034	7212	178
4	7390	7568	7746	7924	8101	8279	8456	8634	8811	8989	178
5	9166	9343	9520	9698	9875						
6	390935	1112	1288	1464	1641	1817	1993	2169	2345	2521	176
7	2697	2873	3048	3224	3400	3575	3751	3926	4101	4277	176
8	4452	4627	4802	4977	5152	5326	5501	5676	5850	6025	175
9	6199	6374	6548	6722	6896	7071	7245	7419	7592	7766	174
250	7940	8114	8287	8461	8634	8808	8981	9154	9328	9501	173
1	9674	9847									
2			0020	0192	0365	0538	0711	0883	1056	1228	173
3	401401	1573	1745	1917	2089	2261	2433	2605	2777	2949	172
4	3121	3292	3464	3635	3807	3978	4149	4320	4492	4663	171
5	4834	5005	5176	5346	5517	5688	5858	6029	6199	6370	171
6	6540	6710	6881	7051	7221	7391	7561	7731	7901	8070	170
7	8240	8410	8579	8749	8918	9087	9257	9426	9595	9764	169
8	9933										
9	411620	1788	1956	2124	2293	2461	2629	2796	2964	3132	168
260	3300	3467	3635	3803	3970	4137	4305	4472	4639	4806	167
1	4973	5140	5307	5474	5641	5808	5974	6141	6308	6474	167
2	6641	6807	6973	7139	7306	7472	7638	7804	7970	8135	166
3	8301	8467	8633	8798	8964	9129	9295	9460	9625	9791	165
4	9956										
5		0121	0286	0451	0616	0781	0945	1110	1275	1439	165
6	421604	1768	1933	2097	2261	2426	2590	2754	2918	3082	164
7	3246	3410	3574	3737	3901	4065	4228	4392	4555	4718	164
8	4882	5045	5208	5371	5534	5697	5860	6023	6186	6349	163
9	6511	6674	6836	6999	7161	7324	7486	7648	7811	7973	162
270	8135	8297	8459	8621	8783	8944	9106	9268	9429	9591	162
280	9752	9914									
290	43		0075	0236	0398	0559	0720	0881	1042	1203	161

## PROPORTIONAL PARTS.

Diff.	1	2	3	4	5	6	7	8	9
178	17.8	35.6	53.4	71.2	89.0	106.8	124.6	142.4	160.2
177	17.7	35.4	53.1	70.8	88.5	106.2	123.9	141.6	159.3
176	17.6	35.2	52.8	70.4	88.0	105.6	123.2	140.8	158.4
175	17.5	35.0	52.5	70.0	87.5	105.0	122.5	140.0	157.5
174	17.4	34.8	52.2	69.6	87.0	104.4	121.8	139.2	156.6
173	17.3	34.6	51.9	69.2	86.5	103.8	121.1	138.4	155.7
172	17.2	34.4	51.6	68.8	86.0	103.2	120.4	137.6	154.8
171	17.1	34.2	51.3	68.4	85.5	102.6	119.7	136.8	153.9
170	17.0	34.0	51.0	68.0	85.0	102.0	119.0	136.0	153.0
169	16.9	33.8	50.7	67.6	84.5	101.4	118.3	135.2	152.1
168	16.8	33.6	50.4	67.2	84.0	100.8	117.6	134.4	151.2
167	16.7	33.4	50.1	66.8	83.5	100.2	116.9	133.6	150.3
166	16.6	33.2	49.8	66.4	83.0	99.6	116.2	132.8	149.4
165	16.5	33.0	49.5	66.0	82.5	99.0	115.5	132.0	148.5
164	16.4	32.8	49.2	65.6	82.0	98.4	114.8	131.2	147.6
163	16.3	32.6	48.9	65.2	81.5	97.8	114.1	130.4	146.7
162	16.2	32.4	48.5	64.8	81.0	97.2	113.4	129.6	145.8
161	16.1	32.2	48.3	64.4	80.5	96.6	112.7	128.8	144.9



No. 270 L. 431.]

[No. 299 L. 476.

N.	0	1	2	3	4	5	6	7	8	9	Diff.
270	431364	1525	1685	1846	2007	2167	2328	2455	2649	2809	161
1	2969	3130	3290	3450	3610	3770	3930	4090	4249	4409	160
2	4569	4729	4888	5048	5207	5367	5526	5685	5844	6004	159
3	6163	6322	6481	6640	6799	6957	7116	7275	7433	7592	159
4	7751	7909	8067	8226	8384	8542	8701	8859	9017	9175	158
5	9333	9491	9648	9806	9964						
6	440909	1066	1224	1381	1538	1695	1852	2009	2166	2323	158
7	2430	2637	2793	2950	3106	3263	3419	3576	3732	3889	157
8	4045	4201	4357	4513	4669	4825	4981	5137	5293	5449	156
9	5604	5760	5915	6071	6226	6382	6537	6692	6848	7003	155
280	7158	7313	7468	7623	7778	7933	8088	8242	8397	8552	155
1	8706	8861	9015	9170	9324	9478	9633	9787	9941		
2										0095	154
3	450249	0403	0557	0711	0865	1018	1172	1326	1479	1633	154
4	1786	1940	2093	2247	2400	2553	2706	2859	3012	3165	153
3	3318	3471	3624	3777	3930	4082	4235	4387	4540	4692	153
5	4845	4997	5150	5302	5454	5606	5758	5910	6062	6214	152
6	6366	6518	6670	6821	6973	7125	7276	7428	7579	7731	152
7	7882	8033	8184	8336	8487	8638	8789	8940	9091	9242	151
8	9392	9543	9694	9845	9995						
9	460398	1048	1198	1348	1499	1649	1799	1948	2098	2248	150
290	2398	2548	2697	2847	2997	3146	3296	3445	3594	3744	150
1	3893	4042	4191	4340	4490	4639	4788	4936	5085	5234	149
2	5383	5532	5680	5829	5977	6126	6274	6423	6571	6719	149
3	6868	7016	7164	7312	7460	7608	7756	7904	8052	8200	148
4	8347	8495	8643	8790	8938	9085	9233	9380	9527	9675	148
5	9322	9469									
6	471292	1433	0116	0263	0410	0557	0704	0851	0998	1145	147
7	2756	2903	1585	1732	1878	2025	2171	2318	2464	2610	146
8	4216	4362	3049	3195	3341	3487	3633	3779	3925	4071	146
9	5671	5816	4503	4653	4799	4944	5090	5235	5381	5526	146
			6107	6252	6397	6542	6687	6832	6976	7121	145

PROPORTIONAL PARTS.

Diff.	1	2	3	4	5	6	7	8	9
161	16.1	32.2	48.3	64.4	80.5	96.6	112.7	128.8	144.9
160	16.0	32.0	48.0	64.0	80.0	96.0	112.0	128.0	144.0
159	15.9	31.8	47.7	63.6	79.5	95.4	111.3	127.2	143.1
158	15.8	31.6	47.4	63.2	79.0	94.8	110.6	126.4	142.2
157	15.7	31.4	47.1	62.8	78.5	94.2	109.9	125.6	141.3
156	15.6	31.2	46.8	62.4	78.0	93.6	109.2	124.8	140.4
155	15.5	31.0	46.5	62.0	77.5	93.0	108.5	124.0	139.5
154	15.4	30.8	46.2	61.6	77.0	92.4	107.8	123.2	138.6
153	15.3	30.6	45.9	61.2	76.5	91.8	107.1	122.4	137.7
152	15.2	30.4	45.6	60.8	76.0	91.2	106.4	121.6	136.8
151	15.1	30.2	45.3	60.4	75.5	90.6	105.7	120.8	135.9
150	15.0	30.0	45.0	60.0	75.0	90.0	105.0	120.0	135.0
149	14.9	29.8	44.7	59.6	74.5	89.4	104.3	119.2	134.1
148	14.8	29.6	44.4	59.2	74.0	88.8	103.6	118.4	133.2
147	14.7	29.4	44.1	58.8	73.5	88.2	102.9	117.6	132.3
146	14.6	29.2	43.8	58.4	73.0	87.6	102.2	116.8	131.4
145	14.5	29.0	43.5	58.0	72.5	87.0	101.5	116.0	130.5
144	14.4	28.8	43.2	57.6	72.0	86.4	100.8	115.2	129.6
143	14.3	28.6	42.9	57.2	71.5	85.8	100.1	114.4	128.7
142	14.2	28.4	42.6	56.8	71.0	85.2	99.4	113.6	127.8
141	14.1	28.2	42.3	56.4	70.5	84.6	98.7	112.8	126.9
140	14.0	28.0	42.0	56.0	70.0	84.0	98.0	112.0	126.0

No. 300 L. 477.]

[No. 339 L. 531.

N.	0	1	2	3	4	5	6	7	8	9	Diff.
300	477121	7266	7411	7555	7700	7844	7989	8133	8278	8422	145
1	8566	8711	8855	8999	9143	9287	9431	9575	9719	9863	144
2	480007	0151	0294	0438	0582	0725	0869	1012	1156	1299	144
3	1443	1586	1729	1872	2016	2159	2302	2445	2588	2731	143
4	2874	3016	3159	3302	3445	3587	3730	3872	4015	4157	143
5	4300	4442	4585	4727	4869	5011	5153	5295	5437	5579	142
6	5721	5863	6005	6147	6289	6430	6572	6714	6855	6997	142
7	7138	7280	7421	7563	7704	7845	7986	8127	8269	8410	141
8	8551	8692	8833	8974	9114	9255	9396	9537	9677	9818	141
9	9958	0099	0239	0380	0520	0661	0801	0941	1081	1222	140
310	491362	1502	1642	1782	1922	2062	2201	2341	2481	2621	140
1	2760	2900	3040	3179	3319	3458	3597	3737	3876	4015	139
2	4155	4294	4433	4572	4711	4850	4989	5128	5267	5406	139
3	5544	5683	5822	5960	6099	6238	6376	6515	6653	6791	139
4	6930	7068	7206	7344	7483	7621	7759	7897	8035	8173	138
5	8311	8448	8586	8724	8862	8999	9137	9275	9412	9550	138
6	9687	9824	9962	0099	0236	0374	0511	0648	0785	0922	137
7	501059	1196	1333	1470	1607	1744	1880	2017	2154	2291	137
8	2427	2564	2700	2837	2973	3109	3246	3382	3518	3655	136
9	3791	3927	4063	4199	4335	4471	4607	4743	4878	5014	136
320	5150	5286	5421	5557	5693	5828	5964	6099	6234	6370	136
1	6505	6640	6776	6911	7046	7181	7316	7451	7586	7721	135
2	7856	7991	8126	8260	8395	8530	8664	8799	8934	9068	135
3	9203	9337	9471	9606	9740	9874	0009	0143	0277	0411	134
4	510545	0679	0813	0947	1081	1215	1349	1482	1616	1750	134
5	1883	2017	2151	2284	2418	2551	2684	2818	2951	3084	133
6	3218	3351	3484	3617	3750	3883	4016	4149	4282	4415	133
7	4548	4681	4813	4946	5079	5211	5344	5476	5609	5741	133
8	5874	6006	6139	6271	6403	6535	6668	6800	6932	7064	132
9	7196	7328	7460	7592	7724	7855	7987	8119	8251	8382	132
330	8514	8646	8777	8909	9040	9171	9303	9434	9566	9697	131
1	9828	9959	0090	0221	0353	0484	0615	0745	0876	1007	131
2	521138	1269	1400	1530	1661	1792	1922	2053	2183	2314	131
3	2444	2575	2705	2835	2966	3096	3226	3356	3486	3616	130
4	3746	3876	4006	4136	4266	4396	4526	4656	4785	4915	130
5	5045	5174	5304	5434	5563	5693	5822	5951	6081	6210	129
6	6339	6469	6598	6727	6856	6985	7114	7243	7372	7501	129
7	7630	7759	7888	8016	8145	8274	8402	8531	8660	8788	129
8	8917	9045	9174	9302	9430	9559	9687	9815	9943	0072	128
9	530200	0328	0456	0584	0712	0840	0968	1096	1223	1351	128

## PROPORTIONAL PARTS.

Diff.	1	2	3	4	5	6	7	8	9
139	13.9	27.8	41.7	55.6	69.5	83.4	97.3	111.2	125.1
138	13.8	27.6	41.4	55.2	69.0	82.8	96.6	110.4	124.2
137	13.7	27.4	41.1	54.8	68.5	82.2	95.9	109.6	123.3
136	13.6	27.2	40.8	54.4	68.0	81.6	95.2	108.8	122.4
135	13.5	27.0	40.5	54.0	67.5	81.0	94.5	108.0	121.5
134	13.4	26.8	40.2	53.6	67.0	80.4	93.8	107.2	120.6
133	13.3	26.6	39.9	53.2	66.5	79.8	93.1	106.4	119.7
132	13.2	26.4	39.6	52.8	66.0	79.2	92.4	105.6	118.8
131	13.1	26.2	39.3	52.4	65.5	78.6	91.7	104.8	117.9
130	13.0	26.0	39.0	52.0	65.0	78.0	91.0	104.0	117.0
129	12.9	25.8	38.7	51.6	64.5	77.4	90.3	103.2	116.1
128	12.8	25.6	38.4	51.2	64.0	76.8	89.6	102.4	115.2
127	12.7	25.4	38.1	50.8	63.5	76.2	88.9	101.6	114.3

No. 340 L. 531.]

[No. 379 L. 579.

N.	0	1	2	3	4	5	6	7	8	9	Diff.
340	531479	1607	1734	1862	1990	2117	2245	2372	2500	2627	128
1	2754	2882	3009	3136	3264	3391	3518	3645	3772	3899	127
2	4026	4153	4280	4407	4534	4661	4787	4914	5041	5167	127
3	5294	5421	5547	5674	5800	5927	6053	6180	6306	6432	126
4	6558	6685	6811	6937	7063	7189	7315	7441	7567	7693	126
5	7819	7945	8071	8197	8322	8448	8574	8699	8825	8951	126
6	9076	9202	9327	9452	9578	9703	9829	9954			
7	540329	0455	0580	0705	0830	0955	1080	1205	1330	1454	125
8	1579	1704	1829	1953	2078	2203	2327	2452	2576	2701	125
9	2825	2950	3074	3199	3323	3447	3571	3696	3820	3944	124
350	4068	4192	4316	4440	4564	4688	4812	4936	5060	5183	124
1	5307	5431	5555	5678	5802	5925	6049	6172	6296	6419	124
2	6543	6666	6789	6913	7036	7159	7282	7405	7529	7652	123
3	7775	7898	8021	8144	8267	8389	8512	8635	8758	8881	123
4	9003	9126	9249	9371	9494	9616	9739	9861	9984		
5	550228	0351	0473	0595	0717	0840	0962	1084	1206	1328	123
6	1450	1572	1694	1816	1938	2060	2181	2303	2425	2547	122
7	2668	2790	2911	3033	3155	3276	3398	3519	3640	3762	121
8	3883	4004	4126	4247	4368	4489	4610	4731	4852	4973	121
9	5094	5215	5336	5457	5578	5699	5820	5940	6061	6182	121
360	6303	6423	6544	6664	6785	6905	7026	7146	7267	7387	120
1	7507	7627	7748	7868	7988	8108	8228	8349	8469	8589	120
2	8709	8829	8948	9068	9188	9308	9428	9548	9667	9787	120
3	9907										
4	561101	0026	0146	0265	0385	0504	0624	0743	0863	0982	119
5	2293	2412	2531	2650	2769	2887	3006	3125	3244	3362	119
6	3481	3600	3718	3837	3955	4074	4192	4311	4429	4548	119
7	4666	4784	4903	5021	5139	5257	5376	5494	5612	5730	118
8	5848	5966	6084	6202	6320	6437	6555	6673	6791	6909	118
9	7026	7144	7262	7379	7497	7614	7732	7849	7967	8084	118
370	8202	8319	8436	8554	8671	8788	8905	9023	9140	9257	117
1	9374	9491	9608	9725	9842	9959					
2	570543	0660	0776	0893	1010	1126	0076	0193	0309	0426	117
3	1709	1825	1942	2058	2174	2291	1243	1359	1476	1592	117
4	2872	2988	3104	3220	3336	3452	2407	2523	2639	2755	116
5	4031	4147	4263	4379	4494	4610	3568	3684	3800	3915	116
6	5188	5303	5419	5534	5650	5765	4726	4841	4957	5072	116
7	6341	6457	6572	6687	6802	6917	5880	5996	6111	6226	115
8	7492	7607	7722	7836	7951	8066	7032	7147	7262	7377	115
9	8639	8754	8868	8983	9097	9212	8181	8295	8410	8525	115
							9326	9441	9555	9669	114

PROPORTIONAL PARTS.

Diff.	1	2	3	4	5	6	7	8	9
128	12.8	25.6	38.4	51.2	64.0	76.8	89.6	102.4	115.2
127	12.7	25.4	38.1	50.8	63.5	76.2	88.9	101.6	114.3
126	12.6	25.2	37.8	50.4	63.0	75.6	88.2	100.8	113.4
125	12.5	25.0	37.5	50.0	62.5	75.0	87.5	100.0	112.5
124	12.4	24.8	37.2	49.6	62.0	74.4	86.8	99.2	111.6
123	12.3	24.6	36.9	49.2	61.5	73.8	86.1	98.4	110.7
122	12.2	24.4	36.6	48.8	61.0	73.2	85.4	97.6	109.8
121	12.1	24.2	36.3	48.4	60.5	72.6	84.7	96.8	108.9
120	12.0	24.0	36.0	48.0	60.0	72.0	84.0	96.0	108.0
119	11.9	23.8	35.7	47.6	59.5	71.4	83.3	95.2	107.1



N.	0	1	2	3	4	5	6	7	8	9	Diff.
380	579784	9898									
1	580925	1039	0012	0126	0241	0355	0469	0583	0697	0811	114
2	2063	2177	1153	1267	1381	1495	1608	1722	1836	1950	
3	3199	3312	2291	2404	2518	2631	2745	2858	2972	3085	
4	4331	4444	3426	3539	3652	3765	3879	3992	4105	4218	
5	5461	5574	4557	4670	4783	4896	5009	5122	5235	5348	113
6	6587	6700	5686	5799	5912	6024	6137	6250	6362	6475	
7	7711	7823	6812	6925	7037	7149	7262	7374	7486	7599	
8	8832	8944	7935	8047	8160	8272	8384	8496	8608	8720	112
9	9950		9056	9167	9279	9391	9503	9615	9726	9838	
		0061	0173	0284	0396	0507	0619	0730	0842	0953	
390	591065	1176	1287	1399	1510	1621	1732	1843	1955	2066	
1	2177	2288	2399	2510	2621	2732	2843	2954	3064	3175	111
2	3286	3397	3508	3618	3729	3840	3950	4061	4171	4282	
3	4393	4503	4614	4724	4834	4945	5055	5165	5276	5386	
4	5496	5606	5717	5827	5937	6047	6157	6267	6377	6487	
5	6597	6707	6817	6927	7037	7146	7256	7366	7476	7586	110
6	7695	7805	7914	8024	8134	8243	8353	8462	8572	8681	
7	8791	8900	9009	9119	9228	9337	9446	9556	9665	9774	
8	9883	9992									109
9	600973	1082	1191	1299	1408	1517	1625	1734	1843	1951	
400	2060	2169	2277	2386	2494	2603	2711	2819	2928	3036	
1	3144	3253	3361	3469	3577	3686	3794	3902	4010	4118	108
2	4226	4334	4442	4550	4658	4766	4874	4982	5089	5197	
3	5305	5413	5521	5628	5736	5844	5951	6059	6166	6274	
4	6381	6489	6596	6704	6811	6919	7026	7133	7241	7348	
5	7455	7562	7669	7777	7884	7991	8098	8205	8312	8419	107
6	8526	8633	8740	8847	8954	9061	9167	9274	9381	9488	
7	9594	9701	9808	9914							
8	610660	0767	0873	0979	0021	0128	0234	0341	0447	0554	
9	1723	1829	1936	2042	1086	1192	1298	1405	1511	1617	
					2148	2254	2360	2466	2572	2678	106
410	2784	2890	2996	3102	3207	3313	3419	3525	3630	3736	
1	3842	3947	4053	4159	4264	4370	4475	4581	4686	4792	
2	4897	5003	5108	5213	5319	5424	5529	5634	5740	5845	
3	5950	6055	6160	6265	6370	6476	6581	6686	6790	6895	105
4	7000	7105	7210	7315	7420	7525	7629	7734	7839	7943	

PROPORTIONAL PARTS.

Diff.	1	2	3	4	5	6	7	8	9
118	11.8	23.6	35.4	47.2	59.0	70.8	82.6	94.4	106.2
117	11.7	23.4	35.1	46.8	58.5	70.2	81.9	93.6	105.3
116	11.6	23.2	34.8	46.4	58.0	69.6	81.2	92.8	104.4
115	11.5	23.0	34.5	46.0	57.5	69.0	80.5	92.0	103.5
114	11.4	22.8	34.2	45.6	57.0	68.4	79.8	91.2	102.6
113	11.3	22.6	33.9	45.2	56.5	67.8	79.1	90.4	101.7
112	11.2	22.4	33.6	44.8	56.0	67.2	78.4	89.6	100.8
111	11.1	22.2	33.3	44.4	55.5	66.6	77.7	88.8	99.9
110	11.0	22.0	33.0	44.0	55.0	66.0	77.0	88.0	99.0
109	10.9	21.8	32.7	43.6	54.5	65.4	76.3	87.2	98.1
108	10.8	21.6	32.4	43.2	54.0	64.8	75.6	86.4	97.2
107	10.7	21.4	32.1	42.8	53.5	64.2	74.9	85.6	96.3
106	10.6	21.2	31.8	42.4	53.0	63.6	74.2	84.8	95.4
105	10.5	21.0	31.5	42.0	52.5	63.0	73.5	84.0	94.5
104	10.4	20.8	31.2	41.6	52.0	62.4	72.8	83.2	93.6



No. 415 L. 618.]

[No. 459 L. 662.

N.	0	1	2	3	4	5	6	7	8	9	Diff.
415	618048	8153	8257	8362	8466	8571	8676	8780	8884	8989	105
6	9093	9198	9302	9406	9511	9615	9719	9824	9928	0032	
7	620136	0240	0344	0448	0552	0656	0760	0864	0968	1072	104
8	1176	1280	1384	1488	1592	1695	1799	1903	2007	2110	
9	2214	2318	2421	2525	2628	2732	2835	2939	3042	3146	
420	3249	3353	3456	3559	3663	3766	3869	3973	4076	4179	
1	4232	4335	4438	4591	4695	4798	4901	5004	5107	5210	103
2	5312	5415	5518	5621	5724	5827	5929	6032	6135	6238	
3	6340	6443	6546	6648	6751	6853	6956	7058	7161	7263	
4	7366	7468	7571	7673	7775	7878	7980	8082	8185	8287	
5	8389	8491	8593	8695	8797	8900	9002	9104	9206	9308	102
6	9410	9512	9613	9715	9817	9919	0021	0123	0224	0326	
7	630428	0530	0631	0733	0835	0936	1038	1139	1241	1342	
8	1444	1545	1647	1748	1849	1951	2052	2153	2255	2356	
9	2457	2559	2660	2761	2862	2963	3064	3165	3266	3367	
430	3468	3569	3670	3771	3872	3973	4074	4175	4276	4376	101
1	4477	4578	4679	4779	4880	4981	5081	5182	5283	5383	
2	5484	5584	5685	5785	5886	5986	6087	6187	6287	6388	
3	6488	6588	6688	6789	6889	6989	7089	7189	7290	7390	
4	7490	7590	7690	7790	7890	7990	8090	8190	8290	8389	100
5	8489	8589	8689	8789	8888	8988	9088	9188	9287	9387	
6	9486	9586	9686	9785	9885	9984	0084	0183	0283	0382	
7	640431	0581	0680	0779	0879	0978	1077	1177	1276	1375	
8	1474	1573	1672	1771	1871	1970	2069	2168	2267	2366	
9	2465	2563	2662	2761	2860	2959	3058	3156	3255	3354	99
440	3453	3551	3650	3749	3847	3946	4044	4143	4242	4340	
1	4439	4537	4636	4734	4832	4931	5029	5127	5226	5324	
2	5422	5521	5619	5717	5815	5913	6011	6110	6208	6306	
3	6404	6502	6600	6698	6796	6894	6992	7089	7187	7285	98
4	7383	7481	7579	7676	7774	7872	7969	8067	8165	8262	
5	8360	8458	8555	8653	8750	8848	8945	9043	9140	9237	
6	9335	9432	9530	9627	9724	9821	9919	0016	0113	0210	
7	650303	0405	0502	0599	0696	0793	0890	0987	1084	1181	
8	1278	1375	1472	1569	1666	1762	1859	1956	2053	2150	97
9	2246	2343	2440	2536	2633	2730	2826	2923	3019	3116	
450	3213	3309	3405	3502	3598	3695	3791	3888	3984	4080	
1	4177	4273	4369	4465	4562	4658	4754	4850	4946	5042	
2	5138	5235	5331	5427	5523	5619	5715	5810	5906	6002	96
3	6098	6194	6290	6386	6482	6577	6673	6769	6864	6960	
4	7056	7152	7247	7343	7438	7534	7629	7725	7820	7916	
5	8011	8107	8202	8298	8393	8488	8584	8679	8774	8870	
6	8965	9060	9155	9250	9346	9441	9536	9631	9726	9821	
7	9916	0011	0106	0201	0296	0391	0486	0581	0676	0771	95
8	660865	0960	1055	1150	1245	1339	1434	1529	1623	1718	
9	1813	1907	2002	2096	2191	2286	2380	2475	2569	2663	

PROPORTIONAL PARTS.

Diff.	1	2	3	4	5	6	7	8	9
105	10.5	21.0	31.5	42.0	52.5	63.0	73.5	84.0	94.5
104	10.4	20.8	31.2	41.6	52.0	62.4	72.8	83.2	93.6
103	10.3	20.6	30.9	41.2	51.5	61.8	72.1	82.4	92.7
102	10.2	20.4	30.6	40.8	51.0	61.2	71.4	81.6	91.8
101	10.1	20.2	30.3	40.4	50.5	60.6	70.7	80.8	90.9
100	10.0	20.0	30.0	40.0	50.0	60.0	70.0	80.0	90.0
99	9.9	19.8	29.7	39.6	49.5	59.4	69.3	79.2	89.1

No. 460 L. 862.]

[No. 499 L. 698.

N.	0	1	2	3	4	5	6	7	8	9	Diff.
460	662758	2852	2947	3041	3135	3230	3324	3418	3512	3607	
1	3701	3795	3889	3983	4078	4172	4266	4360	4454	4548	94
2	4642	4736	4830	4924	5018	5112	5206	5299	5393	5487	
3	5581	5675	5769	5862	5956	6050	6143	6237	6331	6424	
4	6518	6612	6705	6799	6892	6986	7079	7173	7266	7360	
5	7453	7546	7640	7733	7826	7920	8013	8106	8199	8293	
6	8386	8479	8572	8665	8759	8852	8945	9038	9131	9224	
7	9317	9410	9503	9596	9689	9782	9875	9967			
8	670246	0339	0431	0524	0617	0710	0802	0895	0988	1080	
9	1173	1265	1358	1451	1543	1636	1728	1821	1913	2005	
470	2098	2190	2283	2375	2467	2560	2652	2744	2836	2929	
1	3021	3113	3205	3297	3390	3482	3574	3666	3758	3850	92
2	3942	4034	4126	4218	4310	4402	4494	4586	4677	4769	
3	4861	4953	5045	5137	5228	5320	5412	5503	5595	5687	
4	5778	5870	5962	6053	6145	6236	6328	6419	6511	6602	
5	6694	6785	6876	6966	7057	7147	7237	7327	7417	7507	
6	7607	7698	7789	7881	7972	8063	8154	8245	8336	8427	
7	8518	8609	8700	8791	8882	8973	9064	9155	9246	9337	
8	9428	9519	9610	9700	9791	9882	9973				
9	680336	0426	0517	0607	0698	0789	0879	0970	1060	1151	91
480	1241	1332	1422	1513	1603	1693	1784	1874	1964	2055	
1	2145	2235	2326	2416	2506	2596	2686	2777	2867	2957	90
2	3047	3137	3227	3317	3407	3497	3587	3677	3767	3857	
3	3947	4037	4127	4217	4307	4396	4486	4576	4666	4756	
4	4845	4935	5025	5114	5204	5294	5383	5473	5563	5652	
5	5742	5831	5921	6010	6100	6189	6279	6368	6458	6547	
6	6636	6726	6815	6904	6994	7083	7172	7261	7351	7440	
7	7529	7618	7707	7796	7886	7975	8064	8153	8242	8331	
8	8420	8509	8598	8687	8776	8865	8953	9042	9131	9220	
9	9309	9398	9486	9575	9664	9753	9841	9930			
490	690196	0285	0373	0462	0550	0639	0728	0816	0905	0993	89
1	1081	1170	1258	1347	1435	1524	1612	1700	1789	1877	
2	1965	2053	2142	2230	2318	2406	2494	2583	2671	2759	88
3	2847	2935	3023	3111	3199	3287	3375	3463	3551	3639	
4	3727	3815	3903	3991	4078	4166	4254	4342	4430	4517	
5	4605	4693	4781	4868	4956	5044	5131	5219	5307	5394	
6	5482	5569	5657	5744	5832	5919	6007	6094	6182	6269	
7	6356	6444	6531	6618	6706	6793	6880	6968	7055	7142	
8	7229	7317	7404	7491	7578	7665	7752	7839	7926	8014	
9	8100	8188	8275	8362	8449	8535	8622	8709	8796	8883	

PROPORTIONAL PARTS.

Diff.	1	2	3	4	5	6	7	8	9
98	9.8	19.6	29.4	39.2	49.0	58.8	68.6	78.4	88.2
97	9.7	19.4	29.1	38.8	48.5	58.2	67.9	77.6	87.3
96	9.6	19.2	28.8	38.4	48.0	57.6	67.2	76.8	86.4
95	9.5	19.0	28.5	38.0	47.5	57.0	66.5	76.0	85.5
94	9.4	18.8	28.2	37.6	47.0	56.4	65.8	75.2	84.6
93	9.3	18.6	27.9	37.2	46.5	55.8	65.1	74.4	83.7
92	9.2	18.4	27.6	36.8	46.0	55.2	64.4	73.6	82.8
91	9.1	18.2	27.3	36.4	45.5	54.6	63.7	72.8	81.9
90	9.0	18.0	27.0	36.0	45.0	54.0	63.0	72.0	81.0
89	8.9	17.8	26.7	35.6	44.5	53.4	62.3	71.2	80.1
88	8.8	17.6	26.4	35.2	44.0	52.8	61.6	70.4	79.2
87	8.7	17.4	26.1	34.8	43.5	52.2	60.9	69.6	78.3
86	8.6	17.2	25.8	34.4	43.0	51.6	60.2	68.8	77.4

No. 500 L. 698.]

[No. 544 L. 736.

N.	0	1	2	3	4	5	6	7	8	9	Diff.
500	698970	9057	9144	9231	9317	9404	9491	9578	9664	9751	
1	9838	9924									
2	700704	0790	0011	0098	0184	0271	0358	0444	0531	0617	
3	1568	1654	0877	0963	1050	1136	1222	1309	1395	1482	
4	2431	2517	1741	1827	1913	1999	2086	2172	2258	2344	
5	3291	3377	2603	2689	2775	2861	2947	3033	3119	3205	
6	4151	4236	3463	3549	3635	3721	3807	3893	3979	4065	86
7	5008	5094	4322	4408	4494	4579	4665	4751	4837	4922	
8	5864	5949	5179	5265	5350	5436	5522	5607	5693	5778	
9	6718	6803	6035	6120	6206	6291	6376	6462	6547	6632	
			6888	6974	7059	7144	7229	7315	7400	7485	
510	7570	7655	7740	7826	7911	7996	8081	8166	8251	8336	
1	8421	8506	8591	8676	8761	8846	8931	9015	9100	9185	
2	9270	9355	9440	9524	9609	9694	9779	9863	9948		85
3	710117	0202	0287	0371	0456	0540	0625	0710	0794	0879	
4	0963	1048	1132	1217	1301	1385	1470	1554	1639	1723	
5	1807	1892	1976	2060	2144	2229	2313	2397	2481	2566	
6	2650	2734	2818	2902	2986	3070	3154	3238	3323	3407	
7	3491	3575	3659	3742	3826	3910	3994	4078	4162	4246	
8	4330	4414	4497	4581	4665	4749	4833	4916	5000	5084	84
9	5167	5251	5335	5418	5502	5586	5669	5753	5836	5920	
520	6003	6087	6170	6254	6337	6421	6504	6588	6671	6754	
1	6838	6921	7004	7088	7171	7254	7338	7421	7504	7587	
2	7671	7754	7837	7920	8003	8086	8169	8253	8336	8419	
3	8502	8585	8668	8751	8834	8917	9000	9083	9165	9248	83
4	9331	9414	9497	9580	9663	9745	9828	9911	9994		
5	720159	0242	0325	0407	0490	0573	0655	0738	0821	0903	
6	0986	1068	1151	1233	1316	1398	1481	1563	1646	1728	
7	1811	1893	1975	2058	2140	2222	2305	2387	2469	2552	
8	2634	2716	2798	2881	2963	3045	3127	3209	3291	3374	
9	3456	3538	3620	3702	3784	3866	3948	4030	4112	4194	82
530	4276	4358	4440	4522	4604	4685	4767	4849	4931	5013	
1	5095	5176	5258	5340	5422	5503	5585	5667	5748	5830	
2	5912	5993	6075	6156	6238	6320	6401	6483	6564	6646	
3	6727	6809	6890	6972	7053	7134	7216	7297	7379	7460	
4	7541	7623	7704	7785	7866	7948	8029	8110	8191	8273	
5	8354	8435	8516	8597	8678	8759	8841	8922	9003	9084	
6	9165	9246	9327	9408	9489	9570	9651	9732	9813	9893	81
7	9974										
8	730782	0055	0136	0217	0298	0378	0459	0540	0621	0702	
9	1589	0863	0944	1024	1105	1186	1266	1347	1428	1508	
		1669	1750	1830	1911	1991	2072	2152	2233	2313	
540	2394	2474	2555	2635	2715	2796	2876	2956	3037	3117	
1	3197	3278	3358	3438	3518	3598	3679	3759	3839	3919	
2	3999	4079	4160	4240	4320	4400	4480	4560	4640	4720	
3	4800	4880	4960	5040	5120	5200	5279	5359	5439	5519	
4	5599	5679	5759	5838	5918	5998	6078	6157	6237	6317	80

PROPORTIONAL PARTS.

Diff.	1	2	3	4	5	6	7	8	9
87	8.7	17.4	26.1	34.8	43.5	52.2	60.9	69.6	78.3
86	8.6	17.2	25.8	34.4	43.0	51.6	60.2	68.8	77.4
85	8.5	17.0	25.5	34.0	42.5	51.0	59.5	68.0	76.5
84	8.4	16.8	25.2	33.6	42.0	50.4	58.8	67.2	75.6



N.	0	1	2	3	4	5	6	7	8	9	Diff.
545	736397	6476	6556	6635	6715	6795	6874	6954	7034	7113	
6	7193	7272	7352	7431	7511	7590	7670	7749	7829	7908	
7	7987	8067	8146	8225	8305	8384	8463	8543	8622	8701	
8	8781	8860	8939	9018	9097	9177	9256	9335	9414	9493	
9	9572	9651	9731	9810	9889	9968					
							0047	0126	0205	0284	79
550	740363	0442	0521	0600	0678	0757	0836	0915	0994	1073	
1	1152	1230	1309	1388	1467	1546	1624	1703	1782	1860	
2	1939	2018	2096	2175	2254	2332	2411	2489	2568	2647	
3	2725	2804	2882	2961	3039	3118	3196	3275	3353	3431	
4	3510	3588	3667	3745	3823	3902	3980	4058	4136	4215	
5	4293	4371	4449	4528	4606	4684	4762	4840	4919	4997	
6	5075	5153	5231	5309	5387	5465	5543	5621	5699	5777	78
7	5855	5933	6011	6089	6167	6245	6323	6401	6479	6556	
8	6634	6712	6790	6868	6945	7023	7101	7179	7256	7334	
9	7412	7489	7567	7645	7722	7800	7878	7955	8033	8110	
560	8188	8266	8343	8421	8498	8576	8653	8731	8808	8885	
1	8963	9040	9118	9195	9272	9350	9427	9504	9582	9659	
2	9736	9814	9891	9968							
3	750508	0586	0663	0740	0817	0894	0971	1048	1125	1202	
4	1279	1356	1433	1510	1587	1664	1741	1818	1895	1972	77
5	2048	2125	2202	2279	2356	2433	2509	2586	2663	2740	
6	2816	2893	2970	3047	3123	3200	3277	3353	3430	3506	
7	3583	3660	3736	3813	3889	3966	4042	4119	4195	4272	
8	4348	4425	4501	4578	4654	4730	4807	4883	4960	5036	
9	5112	5189	5265	5341	5417	5494	5570	5646	5722	5799	
570	5875	5951	6027	6103	6180	6256	6332	6408	6484	6560	
1	6636	6712	6788	6864	6940	7016	7092	7168	7244	7320	76
2	7396	7472	7548	7624	7700	7775	7851	7927	8003	8079	
3	8155	8230	8306	8382	8458	8533	8609	8685	8761	8836	
4	8912	8988	9063	9139	9214	9290	9366	9441	9517	9592	
5	9668	9743	9819	9894	9970						
6	760422	0498	0573	0649	0724	0799	0875	0950	1025	1101	
7	1176	1251	1326	1402	1477	1552	1627	1702	1778	1853	
8	1928	2003	2078	2153	2228	2303	2378	2453	2529	2604	75
9	2679	2754	2829	2904	2978	3053	3128	3203	3278	3353	
580	3428	3503	3578	3653	3727	3802	3877	3952	4027	4101	
1	4176	4251	4326	4400	4475	4550	4624	4699	4774	4848	
2	4923	4998	5072	5147	5221	5296	5370	5445	5520	5594	
3	5669	5743	5818	5892	5966	6041	6115	6190	6264	6338	
4	6413	6487	6562	6636	6710	6785	6859	6933	7007	7082	

PROPORTIONAL PARTS.

Diff.	1	2	3	4	5	6	7	8	9
83	8.3	16.6	24.9	33.2	41.5	49.8	58.1	66.4	74.7
82	8.2	16.4	24.6	32.8	41.0	49.2	57.4	65.6	73.8
81	8.1	16.2	24.3	32.4	40.5	48.6	56.7	64.8	72.9
80	8.0	16.0	24.0	32.0	40.0	48.0	56.0	64.0	72.0
79	7.9	15.8	23.7	31.6	39.5	47.4	55.3	63.2	71.1
78	7.8	15.6	23.4	31.2	39.0	46.8	54.6	62.4	70.2
77	7.7	15.4	23.1	30.8	38.5	46.2	53.9	61.6	69.3
76	7.6	15.2	22.8	30.4	38.0	45.6	53.2	60.8	68.4
75	7.5	15.0	22.5	30.0	37.5	45.0	52.5	60.0	67.5
74	7.4	14.8	22.2	29.6	37.0	44.4	51.8	59.2	66.6



No. 585 L. 767.]

[No. 629 L. 799

N.	0	1	2	3	4	5	6	7	8	9	Diff.
585	767156	7230	7304	7379	7453	7527	7601	7675	7749	7823	74
6	7898	7972	8046	8120	8194	8268	8342	8416	8490	8564	
7	8638	8712	8786	8860	8934	9008	9082	9156	9230	9303	
8	9377	9451	9525	9599	9673	9746	9820	9894	9968		
9	770115	0189	0263	0336	0410	0484	0557	0631	0705	0042 0778	
590	0852	0926	0999	1073	1146	1220	1293	1367	1440	1514	73
1	1587	1661	1734	1808	1881	1955	2028	2102	2175	2248	
2	2322	2395	2468	2542	2615	2688	2762	2835	2908	2981	
3	3055	3128	3201	3274	3348	3421	3494	3567	3640	3713	
4	3786	3860	3933	4006	4079	4152	4225	4298	4371	4444	
5	4517	4590	4663	4736	4809	4882	4955	5028	5100	5173	
6	5246	5319	5392	5465	5538	5610	5683	5756	5829	5902	
7	5974	6047	6120	6193	6265	6338	6411	6483	6556	6629	
8	6701	6774	6846	6919	6992	7064	7137	7209	7282	7354	
9	7427	7499	7572	7644	7717	7789	7862	7934	8006	8079	
600	8151	8224	8296	8368	8441	8513	8585	8658	8730	8802	72
1	8874	8947	9019	9091	9163	9236	9308	9380	9452	9524	
2	9596	9669	9741	9813	9885	9957	0029	0101	0173	0245	
3	780317	0389	0461	0533	0605	0677	0749	0821	0893	0965	
4	1037	1109	1181	1253	1324	1396	1468	1540	1612	1684	
5	1755	1827	1899	1971	2042	2114	2186	2258	2329	2401	
6	2473	2544	2616	2687	2759	2831	2902	2974	3046	3117	
7	3189	3260	3332	3403	3475	3546	3618	3689	3761	3832	
8	3904	3975	4046	4118	4189	4261	4332	4403	4475	4546	
9	4617	4689	4760	4831	4902	4974	5045	5116	5187	5259	
610	5330	5401	5472	5543	5615	5686	5757	5828	5899	5970	71
1	6041	6112	6183	6254	6325	6396	6467	6538	6609	6680	
2	6751	6822	6893	6964	7035	7106	7177	7248	7319	7390	
3	7460	7531	7602	7673	7744	7815	7885	7956	8027	8098	
4	8168	8239	8310	8381	8451	8522	8593	8663	8734	8804	
5	8875	8946	9016	9087	9157	9228	9299	9369	9440	9510	
6	9581	9651	9722	9792	9863	9933	0004	0074	0144	0215	
7	790285	0356	0426	0496	0567	0637	0707	0778	0848	0918	
8	0988	1059	1129	1199	1269	1340	1410	1480	1550	1620	
9	1691	1761	1831	1901	1971	2041	2111	2181	2252	2322	
620	2392	2462	2532	2602	2672	2742	2812	2882	2952	3022	70
1	3092	3162	3231	3301	3371	3441	3511	3581	3651	3721	
2	3790	3860	3930	4000	4070	4139	4209	4279	4349	4418	
3	4488	4558	4627	4697	4767	4836	4906	4976	5045	5115	
4	5185	5254	5324	5393	5463	5532	5602	5672	5741	5811	
5	5880	5949	6019	6088	6158	6227	6297	6366	6436	6505	
6	6574	6644	6713	6782	6852	6921	6990	7060	7129	7198	
7	7268	7337	7406	7475	7545	7614	7683	7752	7821	7890	
8	7960	8029	8098	8167	8236	8305	8374	8443	8513	8582	
9	8651	8720	8789	8858	8927	8996	9065	9134	9203	9272	

PROPORTIONAL PARTS.

Diff.	1	2	3	4	5	6	7	8	9
75	7.5	15.0	22.5	30.0	37.5	45.0	52.5	60.0	67.5
74	7.4	14.8	22.2	29.6	37.0	44.4	51.8	59.2	66.6
73	7.3	14.6	21.9	29.2	36.5	43.8	51.1	58.4	65.7
72	7.2	14.4	21.6	28.8	36.0	43.2	50.4	57.6	64.8
71	7.1	14.2	21.3	28.4	35.5	42.6	49.7	56.8	63.9
70	7.0	14.0	21.0	28.0	35.0	42.0	49.0	56.0	63.0
69	6.9	13.8	20.7	27.6	34.5	41.4	48.3	55.2	62.1

No. 630 L. 799.]

[No. 674 L. 829.

N.	0	1	2	3	4	5	6	7	8	9	Diff.
630	799341	9409	9478	9547	9616	9685	9754	9823	9892	9961	
1	800029	0098	0167	0236	0305	0373	0442	0511	0580	0648	
2	0717	0786	0854	0923	0992	1061	1129	1198	1266	1335	
3	1404	1472	1541	1609	1678	1747	1815	1884	1952	2021	
4	2089	2158	2226	2295	2363	2432	2500	2568	2637	2705	
5	2774	2842	2910	2979	3047	3116	3184	3252	3321	3389	
6	3457	3525	3594	3662	3730	3798	3867	3935	4003	4071	
7	4139	4208	4276	4344	4412	4480	4548	4616	4685	4753	
8	4821	4889	4957	5025	5093	5161	5229	5297	5365	5433	68
9	5501	5569	5637	5705	5773	5841	5908	5976	6044	6112	
640	806180	6248	6316	6384	6451	6519	6587	6655	6723	6790	
1	6858	6926	6994	7061	7129	7197	7264	7332	7400	7467	
2	7535	7603	7670	7738	7806	7873	7941	8008	8076	8143	
3	8211	8279	8346	8414	8481	8549	8616	8684	8751	8818	
4	8886	8953	9021	9088	9156	9223	9290	9358	9425	9492	
5	9560	9627	9694	9762	9829	9896		0031	0098	0165	
6	810233	0300	0367	0434	0501	0569	0636	0703	0770	0837	
7	0904	0971	1039	1106	1173	1240	1307	1374	1441	1508	67
8	1575	1642	1709	1776	1843	1910	1977	2044	2111	2178	
9	2245	2312	2379	2445	2512	2579	2646	2713	2780	2847	
650	2913	2980	3047	3114	3181	3247	3314	3381	3448	3514	
1	3581	3648	3714	3781	3848	3914	3981	4048	4114	4181	
2	4248	4314	4381	4447	4514	4581	4647	4714	4780	4847	
3	4913	4980	5046	5113	5179	5246	5312	5378	5445	5511	
4	5578	5644	5711	5777	5843	5910	5976	6042	6109	6175	
5	6241	6308	6374	6440	6506	6573	6639	6705	6771	6838	
6	6904	6970	7036	7102	7169	7235	7301	7367	7433	7499	
7	7565	7631	7698	7764	7830	7896	7962	8028	8094	8160	
8	8226	8292	8358	8424	8490	8556	8622	8688	8754	8820	66
9	8885	8951	9017	9083	9149	9215	9281	9346	9412	9478	
660	9544	9610	9676	9741	9807	9873	9939		0004	0070	0136
1	820201	0267	0333	0399	0464	0530	0595	0661	0727	0792	
2	0858	0924	0989	1055	1120	1186	1251	1317	1382	1448	
3	1514	1579	1645	1710	1775	1841	1906	1972	2037	2103	
4	2168	2233	2299	2364	2430	2495	2560	2626	2691	2756	
5	2822	2887	2952	3018	3083	3148	3213	3279	3344	3409	
6	3474	3539	3605	3670	3735	3800	3865	3930	3996	4061	
7	4126	4191	4256	4321	4386	4451	4516	4581	4646	4711	
8	4776	4841	4906	4971	5036	5101	5166	5231	5296	5361	65
9	5426	5491	5556	5621	5686	5751	5815	5880	5945	6010	
670	6075	6140	6204	6269	6334	6399	6464	6528	6593	6658	
1	6723	6787	6852	6917	6981	7046	7111	7175	7240	7305	
2	7369	7434	7499	7563	7628	7692	7757	7821	7886	7951	
3	8015	8080	8144	8209	8273	8338	8402	8467	8531	8595	
4	8660	8724	8789	8853	8918	8982	9046	9111	9175	9239	

PROPORTIONAL PARTS.

Diff.	1	2	3	4	5	6	7	8	9
68	6.8	13.6	20.4	27.2	34.0	40.8	47.6	54.4	61.2
67	6.7	13.4	20.1	26.8	33.5	40.2	46.9	53.6	60.3
66	6.6	13.2	19.8	26.4	33.0	39.6	46.2	52.8	59.4
65	6.5	13.0	19.5	26.0	32.5	39.0	45.5	52.0	58.5
64	6.4	12.8	19.2	25.6	32.0	38.4	44.8	51.2	57.6

No. 675 L. 829.]

[No. 719 L. 857

N.	0	1	2	3	4	5	6	7	8	9	Diff.
675	829304	9368	9432	9497	9561	9625	9690	9754	9818	9882	
6	9947										
7	830589	0011	0075	0139	0204	0268	0332	0396	0460	0525	
8	1230	0653	0717	0781	0845	0909	0973	1037	1102	1166	
9	1870	1294	1358	1422	1486	1550	1614	1678	1742	1806	64
		1934	1998	2062	2126	2189	2253	2317	2381	2445	
680	2509	2573	2637	2700	2764	2828	2892	2956	3020	3083	
1	3147	3211	3275	3338	3402	3466	3530	3593	3657	3721	
2	3784	3848	3912	3975	4039	4103	4166	4230	4294	4357	
3	4421	4484	4548	4611	4675	4739	4802	4866	4929	4993	
4	5056	5120	5183	5247	5310	5373	5437	5500	5564	5627	
5	5691	5754	5817	5881	5944	6007	6071	6134	6197	6261	
6	6324	6387	6451	6514	6577	6641	6704	6767	6830	6894	
7	6957	7020	7083	7146	7210	7273	7336	7399	7462	7525	
8	7588	7652	7715	7778	7841	7904	7967	8030	8093	8156	63
9	8219	8282	8345	8408	8471	8534	8597	8660	8723	8786	
690	8849	8912	8975	9038	9101	9164	9227	9289	9352	9415	
1	9478	9541	9604	9667	9729	9792	9855	9918	9981		
2	840106	0169	0232	0294	0357	0420	0482	0545	0608	0671	
3	0733	0796	0859	0921	0984	1046	1109	1172	1234	1297	
4	1359	1422	1485	1547	1610	1672	1735	1797	1860	1922	
5	1985	2047	2110	2172	2235	2297	2360	2422	2484	2547	
6	2609	2672	2734	2796	2859	2921	2983	3046	3108	3170	
7	3233	3295	3357	3420	3482	3544	3606	3669	3731	3793	
8	3855	3918	3980	4042	4104	4166	4229	4291	4353	4415	
9	4477	4539	4601	4664	4726	4788	4850	4912	4974	5036	
700	5098	5160	5222	5284	5346	5408	5470	5532	5594	5656	62
1	5718	5780	5842	5904	5966	6028	6090	6151	6213	6275	
2	6337	6399	6461	6523	6585	6646	6708	6770	6832	6894	
3	6955	7017	7079	7141	7202	7264	7326	7388	7449	7511	
4	7573	7634	7696	7758	7819	7881	7943	8004	8066	8128	
5	8189	8251	8312	8374	8435	8497	8559	8620	8682	8743	
6	8805	8866	8928	8989	9051	9112	9174	9235	9297	9358	
7	9419	9481	9542	9604	9665	9726	9788	9849	9911	9972	
8	850033	0095	0156	0217	0279	0340	0401	0462	0524	0585	
9	0646	0707	0769	0830	0891	0952	1014	1075	1136	1197	
710	1258	1320	1381	1442	1503	1564	1625	1686	1747	1809	
1	1870	1931	1992	2053	2114	2175	2236	2297	2358	2419	61
2	2480	2541	2602	2663	2724	2785	2846	2907	2968	3029	
3	3090	3150	3211	3272	3333	3394	3455	3516	3577	3637	
4	3698	3759	3820	3881	3941	4002	4063	4124	4185	4245	
5	4306	4367	4428	4488	4549	4610	4670	4731	4792	4852	
6	4913	4974	5034	5095	5156	5216	5277	5337	5398	5459	
7	5519	5580	5640	5701	5761	5822	5882	5943	6003	6064	
8	6124	6185	6245	6306	6366	6427	6487	6548	6608	6668	
9	6729	6789	6850	6910	6970	7031	7091	7152	7212	7272	

PROPORTIONAL PARTS.

Diff.	1	2	3	4	5	6	7	8	9
65	6.5	13.0	19.5	26.0	32.5	39.0	45.5	52.0	58.5
64	6.4	12.8	19.2	25.6	32.0	38.4	44.8	51.2	57.6
63	6.3	12.6	18.9	25.2	31.5	37.8	44.1	50.4	56.7
62	6.2	12.4	18.6	24.8	31.0	37.2	43.4	49.6	55.8
61	6.1	12.2	18.3	24.4	30.5	36.6	42.7	48.8	54.9
60	6.0	12.0	18.0	24.0	30.0	36.0	42.0	48.0	54.0

No. 720 L. 857.]

[No. 764 L. 883.

N.	0	1	2	3	4	5	6	7	8	9	Diff.
720	857332	7393	7453	7513	7574	7634	7694	7755	7815	7875	60
1	7935	7995	8056	8116	8176	8236	8297	8357	8417	8477	
2	8537	8597	8657	8718	8778	8838	8898	8958	9018	9078	
3	9138	9198	9258	9318	9379	9439	9499	9559	9619	9679	
4	9739	9799	9859	9918	9978						
5	860338	0398	0458	0518	0578	0638	0698	0758	0818	0878	
6	0937	0996	1056	1116	1176	1236	1295	1355	1415	1475	
7	1534	1594	1654	1714	1773	1833	1893	1952	2012	2072	
8	2131	2191	2251	2310	2370	2430	2489	2549	2608	2668	
9	2728	2787	2847	2906	2966	3025	3085	3144	3204	3263	
730	3323	3382	3442	3501	3561	3620	3680	3739	3799	3858	59
1	3917	3977	4036	4096	4155	4214	4274	4333	4392	4452	
2	4511	4570	4630	4689	4748	4808	4867	4926	4985	5045	
3	5104	5163	5222	5282	5341	5400	5459	5519	5578	5637	
4	5696	5755	5814	5874	5933	5992	6051	6110	6169	6228	
5	6287	6346	6405	6465	6524	6583	6642	6701	6760	6819	
6	6878	6937	6996	7055	7114	7173	7232	7291	7350	7409	
7	7467	7526	7585	7644	7703	7762	7821	7880	7939	7998	
8	8056	8115	8174	8233	8292	8350	8409	8468	8527	8586	
9	8644	8703	8762	8821	8879	8938	8997	9056	9114	9173	
740	9232	9290	9349	9408	9466	9525	9584	9642	9701	9760	58
1	9818	9877	9935	9994							
2	870404	0462	0521	0579	0638	0696	0755	0813	0872	0930	
3	0989	1047	1106	1164	1223	1281	1339	1398	1456	1515	
4	1573	1631	1690	1748	1806	1865	1923	1981	2040	2098	
5	2156	2215	2273	2331	2389	2448	2506	2564	2622	2681	
6	2739	2797	2855	2913	2972	3030	3088	3146	3204	3262	
7	3321	3379	3437	3495	3553	3611	3669	3727	3785	3844	
8	3902	3960	4018	4076	4134	4192	4250	4308	4366	4424	
9	4482	4540	4598	4656	4714	4772	4830	4888	4945	5003	
750	5061	5119	5177	5235	5293	5351	5409	5466	5524	5582	57
1	5640	5698	5756	5813	5871	5929	5987	6045	6102	6160	
2	6218	6276	6333	6391	6449	6507	6564	6622	6680	6737	
3	6795	6853	6910	6968	7026	7083	7141	7199	7256	7314	
4	7371	7429	7487	7544	7602	7659	7717	7774	7832	7889	
5	7947	8004	8062	8119	8177	8234	8292	8349	8407	8464	
6	8522	8579	8637	8694	8752	8809	8866	8924	8981	9039	
7	9096	9153	9211	9268	9325	9383	9440	9497	9555	9612	
8	9669	9726	9784	9841	9898	9956					
9	880242	0299	0356	0413	0471	0528	0585	0642	0699	0756	
760	0814	0871	0928	0985	1042	1099	1156	1213	1271	1328	57
1	1385	1442	1499	1556	1613	1670	1727	1784	1841	1898	
2	1955	2012	2069	2126	2183	2240	2297	2354	2411	2468	
3	2525	2581	2638	2695	2752	2809	2866	2923	2980	3037	
4	3093	3150	3207	3264	3321	3377	3434	3491	3548	3605	

PROPORTIONAL PARTS.

Diff.	1	2	3	4	5	6	7	8	9
59	5.9	11.8	17.7	23.6	29.5	35.4	41.3	47.2	53.1
58	5.8	11.6	17.4	23.2	29.0	34.8	40.6	46.4	52.2
57	5.7	11.4	17.1	22.8	28.5	34.2	39.9	45.6	51.3
56	5.6	11.2	16.8	22.4	28.0	33.6	39.2	44.8	50.4



No. 765 L. 883.]

[No. 809 L. 908.

N.	0	1	2	3	4	5	6	7	8	9	Diff.
765	883661	3718	3775	3832	3888	3945	4002	4059	4115	4172	
6	4229	4285	4342	4399	4455	4512	4569	4625	4682	4739	
7	4795	4852	4909	4965	5022	5078	5135	5192	5248	5305	
8	5361	5418	5474	5531	5587	5644	5700	5757	5813	5870	
9	5926	5983	6039	6096	6152	6209	6265	6321	6378	6434	
770	6491	6547	6604	6660	6716	6773	6829	6885	6942	6998	
1	7054	7111	7167	7223	7280	7336	7392	7449	7505	7561	
2	7617	7674	7730	7786	7842	7898	7955	8011	8067	8123	
3	8179	8236	8292	8348	8404	8460	8516	8573	8629	8685	
4	8741	8797	8853	8909	8965	9021	9077	9134	9190	9246	
5	9302	9358	9414	9470	9526	9582	9638	9694	9750	9806	56
6	9862	9918	9974								
7	890421	0477	0533	0589	0645	0700	0756	0812	0868	0924	
8	0980	1035	1091	1147	1203	1259	1314	1370	1426	1482	
9	1537	1593	1649	1705	1760	1816	1872	1928	1983	2039	
780	2095	2150	2206	2262	2317	2373	2429	2484	2540	2595	
1	2651	2707	2762	2818	2873	2929	2985	3040	3096	3151	
2	3207	3262	3318	3373	3429	3484	3540	3595	3651	3706	
3	3762	3817	3873	3928	3984	4039	4094	4150	4205	4261	
4	4316	4371	4427	4482	4538	4593	4648	4704	4759	4814	
5	4870	4925	4980	5036	5091	5146	5201	5257	5312	5367	
6	5423	5478	5533	5588	5644	5699	5754	5809	5864	5920	
7	5975	6030	6085	6140	6195	6251	6306	6361	6416	6471	
8	6526	6581	6636	6692	6747	6802	6857	6912	6967	7022	
9	7077	7132	7187	7242	7297	7352	7407	7462	7517	7572	55
790	7627	7682	7737	7792	7847	7902	7957	8012	8067	8122	
1	8176	8231	8286	8341	8396	8451	8506	8561	8615	8670	
2	8725	8780	8835	8890	8944	8999	9054	9109	9164	9218	
3	9273	9328	9383	9437	9492	9547	9602	9656	9711	9766	
4	9821	9875	9930	9985							
5	900367	0422	0476	0531	0586	0640	0695	0749	0804	0859	
6	0913	0968	1022	1077	1131	1186	1240	1295	1349	1404	
7	1458	1513	1567	1622	1676	1731	1785	1840	1894	1948	
8	2003	2057	2112	2166	2221	2275	2329	2384	2438	2492	
9	2547	2601	2655	2710	2764	2818	2873	2927	2981	3036	
800	3090	3144	3199	3253	3307	3361	3416	3470	3524	3578	
1	3633	3687	3741	3795	3849	3904	3958	4012	4066	4120	
2	4174	4229	4283	4337	4391	4445	4499	4553	4607	4661	
3	4716	4770	4824	4878	4932	4986	5040	5094	5148	5202	
4	5256	5310	5364	5418	5472	5526	5580	5634	5688	5742	54
5	5796	5850	5904	5958	6012	6066	6119	6173	6227	6281	
6	6335	6389	6443	6497	6551	6604	6658	6712	6766	6820	
7	6874	6927	6981	7035	7089	7143	7196	7250	7304	7358	
8	7411	7465	7519	7573	7626	7680	7734	7787	7841	7895	
9	7949	8002	8056	8110	8163	8217	8270	8324	8378	8431	

PROPORTIONAL PARTS.

Diff.	1	2	3	4	5	6	7	8	9
57	5.7	11.4	17.1	22.8	28.5	34.2	39.9	45.6	51.3
56	5.6	11.2	16.8	22.4	28.0	33.6	39.2	44.8	50.4
55	5.5	11.0	16.5	22.0	27.5	33.0	38.5	44.0	49.5
54	5.4	10.8	16.2	21.6	27.0	32.4	37.8	43.2	48.6

No. 810 L. 908.]

[No. 854 L. 931

N.	0	1	2	3	4	5	6	7	8	9	Diff.
810	908485	8539	8592	8646	8699	8753	8807	8860	8914	8967	
1	9021	9074	9128	9181	9235	9289	9342	9396	9449	9503	
2	9556	9610	9663	9716	9770	9823	9877	9930	9984		
3	910091	0144	0197	0251	0304	0358	0411	0464	0518	0571	
4	0624	0678	0731	0784	0838	0891	0944	0998	1051	1104	
5	1158	1211	1264	1317	1371	1424	1477	1530	1584	1637	
6	1690	1743	1797	1850	1903	1956	2009	2063	2116	2169	
7	2222	2275	2328	2381	2435	2488	2541	2594	2647	2700	
8	2753	2806	2859	2913	2966	3019	3072	3125	3178	3231	
9	3284	3337	3390	3443	3496	3549	3602	3655	3708	3761	53
820	3814	3867	3920	3973	4026	4079	4132	4184	4237	4290	
1	4343	4396	4449	4502	4555	4608	4660	4713	4766	4819	
2	4872	4925	4977	5030	5083	5136	5189	5241	5294	5347	
3	5400	5453	5505	5558	5611	5664	5716	5769	5822	5875	
4	5927	5980	6033	6085	6138	6191	6243	6296	6349	6401	
5	6454	6507	6559	6612	6664	6717	6770	6822	6875	6927	
6	6980	7033	7085	7138	7190	7243	7295	7348	7400	7453	
7	7506	7558	7611	7663	7716	7768	7820	7873	7925	7978	
8	8030	8083	8135	8188	8240	8293	8345	8397	8450	8502	
9	8555	8607	8659	8712	8764	8816	8869	8921	8973	9026	
830	9078	9130	9183	9235	9287	9340	9392	9444	9496	9549	
1	9601	9653	9706	9758	9810	9862	9914	9967			
2	920123	0176	0228	0280	0332	0384	0436	0489	0541	0593	
3	0645	0697	0749	0801	0853	0906	0958	1010	1062	1114	52
4	1166	1218	1270	1322	1374	1426	1478	1530	1582	1634	
5	1686	1738	1790	1842	1894	1946	1998	2050	2102	2154	
6	2206	2258	2310	2362	2414	2466	2518	2570	2622	2674	
7	2725	2777	2829	2881	2933	2985	3037	3089	3140	3192	
8	3244	3296	3348	3399	3451	3503	3555	3607	3658	3710	
9	3762	3814	3865	3917	3969	4021	4072	4124	4176	4228	
840	4279	4331	4383	4434	4486	4538	4589	4641	4693	4744	
1	4796	4848	4899	4951	5003	5054	5106	5157	5209	5261	
2	5312	5364	5415	5467	5518	5570	5621	5673	5725	5776	
3	5828	5879	5931	5982	6034	6085	6137	6188	6240	6291	
4	6342	6394	6445	6497	6548	6600	6651	6702	6754	6805	
5	6857	6908	6959	7011	7062	7114	7165	7216	7268	7319	
6	7370	7422	7473	7524	7576	7627	7678	7730	7781	7832	
7	7883	7935	7986	8037	8088	8140	8191	8242	8293	8345	
8	8396	8447	8498	8549	8601	8652	8703	8754	8805	8857	
9	8908	8959	9010	9061	9112	9163	9215	9266	9317	9368	
850	9419	9470	9521	9572	9623	9674	9725	9776	9827	9879	
1	9930	9981									51
2	930440	0491	0032	0083	0134	0185	0236	0287	0338	0389	
3	0949	1000	0542	0592	0643	0694	0745	0796	0847	0898	
4	1458	1509	1051	1102	1153	1204	1254	1305	1356	1407	
			1560	1610	1661	1712	1763	1814	1865	1915	

## PROPORTIONAL PARTS.

Diff.	1	2	3	4	5	6	7	8	9
53	5.3	10.6	15.9	21.2	26.5	31.8	37.1	42.4	47.7
52	5.2	10.4	15.6	20.8	26.0	31.2	36.4	41.6	46.8
51	5.1	10.2	15.3	20.4	25.5	30.6	35.7	40.8	45.9
50	5.0	10.0	15.0	20.0	25.0	30.0	35.0	40.0	45.0

No. 855 L. 931.]

[No. 899 L. 954.

N.	0	1	2	3	4	5	6	7	8	9	Diff.
855	931966	2017	2068	2118	2169	2220	2271	2322	2372	2423	
6	2474	2524	2575	2626	2677	2727	2778	2829	2879	2930	
7	2981	3031	3082	3133	3183	3234	3285	3335	3386	3437	
8	3487	3538	3589	3639	3690	3740	3791	3841	3892	3943	
9	3993	4044	4094	4145	4195	4246	4296	4347	4397	4448	
860	4498	4549	4599	4650	4700	4751	4801	4852	4902	4953	
1	5003	5054	5104	5154	5205	5255	5306	5356	5406	5457	
2	5507	5558	5608	5658	5709	5759	5809	5860	5910	5960	
3	6011	6061	6111	6162	6212	6262	6313	6363	6413	6463	
4	6514	6564	6614	6665	6715	6765	6815	6865	6916	6966	
5	7016	7066	7116	7167	7217	7267	7317	7367	7418	7468	
6	7518	7568	7618	7668	7718	7769	7819	7869	7919	7969	
7	8019	8069	8119	8169	8219	8269	8320	8370	8420	8470	50
8	8520	8570	8620	8670	8720	8770	8820	8870	8920	8970	
9	9020	9070	9120	9170	9220	9270	9320	9369	9419	9469	
870	9519	9569	9619	9669	9719	9769	9819	9869	9918	9968	
1	940018	0068	0118	0168	0218	0267	0317	0367	0417	0467	
2	0516	0566	0616	0666	0716	0765	0815	0865	0915	0964	
3	1014	1064	1114	1163	1213	1263	1313	1362	1412	1462	
4	1511	1561	1611	1660	1710	1760	1809	1859	1909	1958	
5	2003	2053	2102	2152	2202	2252	2302	2352	2402	2452	
6	2504	2554	2603	2653	2702	2752	2801	2851	2901	2950	
7	3000	3049	3099	3148	3198	3247	3297	3346	3396	3445	
8	3495	3544	3593	3643	3692	3742	3791	3841	3890	3939	
9	3989	4038	4088	4137	4186	4236	4285	4335	4384	4433	
880	4483	4532	4581	4631	4680	4729	4779	4828	4877	4927	
1	4976	5025	5074	5124	5173	5222	5272	5321	5370	5419	
2	5469	5518	5567	5616	5665	5715	5764	5813	5862	5912	
3	5961	6010	6059	6108	6157	6207	6256	6305	6354	6403	
4	6452	6501	6551	6600	6649	6698	6747	6796	6845	6894	
5	6943	6992	7041	7090	7139	7189	7238	7287	7336	7385	
6	7434	7483	7532	7581	7630	7679	7728	7777	7826	7875	49
7	7924	7973	8022	8070	8119	8168	8217	8266	8315	8364	
8	8413	8462	8511	8560	8608	8657	8706	8755	8804	8853	
9	8902	8951	8999	9048	9097	9146	9195	9244	9292	9341	
890	9390	9439	9488	9536	9585	9634	9683	9731	9780	9829	
1	9878	9926	9975								
2	950365	0414	0462	0511	0560	0608	0657	0706	0754	0803	
3	0851	0900	0949	0997	1046	1095	1143	1192	1240	1289	
4	1338	1386	1435	1483	1532	1580	1629	1677	1726	1775	
5	1823	1872	1920	1969	2017	2066	2114	2163	2211	2260	
6	2308	2356	2405	2453	2502	2550	2599	2647	2696	2744	
7	2792	2841	2889	2938	2986	3034	3083	3131	3180	3228	
8	3276	3325	3373	3421	3470	3518	3566	3615	3663	3711	
9	3760	3808	3856	3905	3953	4001	4049	4098	4146	4194	

PROPORTIONAL PARTS.

Diff.	1	2	3	4	5	6	7	8	9
51	5.1	10.2	15.3	20.4	25.5	30.6	35.7	40.8	45.9
50	5.0	10.0	15.0	20.0	25.0	30.0	35.0	40.0	45.0
49	4.9	9.8	14.7	19.6	24.5	29.4	34.3	39.2	44.1
48	4.8	9.6	14.4	19.2	24.0	28.8	33.6	38.4	43.2

No. 900 L. 954.]

[No. 944 L. 975.

N.	0	1	2	3	4	5	6	7	8	9	Diff.
900	954243	4291	4339	4387	4435	4484	4532	4580	4628	4677	48
1	4725	4773	4821	4869	4918	4966	5014	5062	5110	5158	
2	5207	5255	5303	5351	5399	5447	5495	5543	5592	5640	
3	5688	5736	5784	5832	5880	5928	5976	6024	6072	6120	
4	6168	6216	6265	6313	6361	6409	6457	6505	6553	6601	
5	6649	6697	6745	6793	6840	6888	6936	6984	7032	7080	
6	7128	7176	7224	7272	7320	7368	7416	7464	7512	7559	
7	7607	7655	7703	7751	7799	7847	7894	7942	7990	8038	
8	8086	8134	8181	8229	8277	8325	8373	8421	8468	8516	
9	8564	8612	8659	8707	8755	8803	8850	8898	8946	8994	
910	9041	9089	9137	9185	9232	9280	9328	9375	9423	9471	47
1	9518	9566	9614	9661	9709	9757	9804	9852	9900	9947	
2	9995	0042	0090	0138	0185	0233	0280	0328	0376	0423	
3	960471	0518	0566	0613	0661	0709	0756	0804	0851	0899	
4	0946	0994	1041	1089	1136	1184	1231	1279	1326	1374	
5	1421	1469	1516	1563	1611	1658	1706	1753	1801	1848	
6	1895	1943	1990	2038	2085	2132	2180	2227	2275	2322	
7	2369	2417	2464	2511	2559	2606	2653	2701	2748	2795	
8	2843	2890	2937	2985	3032	3079	3126	3174	3221	3268	
9	3316	3363	3410	3457	3504	3552	3599	3646	3693	3741	
920	3788	3835	3882	3929	3977	4024	4071	4118	4165	4212	46
1	4260	4307	4354	4401	4448	4495	4542	4590	4637	4684	
2	4731	4778	4825	4872	4919	4966	5013	5061	5108	5155	
3	5202	5249	5296	5343	5390	5437	5484	5531	5578	5625	
4	5672	5719	5766	5813	5860	5907	5954	6001	6048	6095	
5	6142	6189	6236	6283	6329	6376	6423	6470	6517	6564	
6	6611	6658	6705	6752	6799	6845	6892	6939	6986	7033	
7	7080	7127	7173	7220	7267	7314	7361	7408	7454	7501	
8	7548	7595	7642	7688	7735	7782	7829	7875	7922	7969	
9	8016	8062	8109	8156	8203	8249	8296	8343	8390	8436	
930	8483	8530	8576	8623	8670	8716	8763	8810	8856	8903	46
1	8950	8996	9043	9090	9136	9183	9229	9276	9323	9369	
2	9416	9463	9509	9556	9602	9649	9695	9742	9789	9835	
3	9882	9928	9975	0021	0068	0114	0161	0207	0254	0300	
4	970347	0393	0440	0486	0533	0579	0626	0672	0719	0765	
5	0812	0858	0904	0951	0997	1044	1090	1137	1183	1229	
6	1276	1322	1369	1415	1461	1508	1554	1601	1647	1693	
7	1740	1786	1832	1879	1925	1971	2018	2064	2110	2157	
8	2203	2249	2295	2342	2388	2434	2481	2527	2573	2619	
9	2666	2712	2758	2804	2851	2897	2943	2989	3035	3082	
940	3128	3174	3220	3266	3313	3359	3405	3451	3497	3543	46
1	3590	3636	3682	3728	3774	3820	3866	3913	3959	4005	
2	4051	4097	4143	4189	4235	4281	4327	4374	4420	4466	
3	4512	4558	4604	4650	4696	4742	4788	4834	4880	4926	
4	4972	5018	5064	5110	5156	5202	5248	5294	5340	5386	

PROPORTIONAL PARTS.

Diff.	1	2	3	4	5	6	7	8	9
47	4.7	9.4	14.1	18.8	23.5	28.2	32.9	37.6	42.3
46	4.6	9.2	13.8	18.4	23.0	27.6	32.2	36.8	41.4



No. 945 L. 975.]

[No. 989 L. 995.

N.	0	1	2	3	4	5	6	7	8	9	Diff.
945	975432	5478	5524	5570	5616	5662	5707	5753	5799	5845	
6	5891	5937	5983	6029	6075	6121	6167	6212	6258	6304	
7	6350	6396	6442	6488	6533	6579	6625	6671	6717	6763	
8	6808	6854	6900	6946	6992	7037	7083	7129	7175	7220	
9	7266	7312	7358	7403	7449	7495	7541	7586	7632	7678	
950	7724	7769	7815	7861	7906	7952	7998	8043	8089	8135	
1	8181	8226	8272	8317	8363	8409	8454	8500	8546	8591	
2	8637	8683	8728	8774	8819	8865	8911	8956	9002	9047	
3	9093	9138	9184	9230	9275	9321	9366	9412	9457	9503	
4	9548	9594	9639	9685	9730	9776	9821	9867	9912	9958	
5	980003	0049	0094	0140	0185	0231	0276	0322	0367	0412	
6	0458	0503	0549	0594	0640	0685	0730	0776	0821	0867	
7	0912	0957	1003	1048	1093	1139	1184	1229	1275	1320	
8	1366	1411	1456	1501	1547	1592	1637	1683	1728	1773	
9	1819	1864	1909	1954	2000	2045	2090	2135	2181	2226	
960	2271	2316	2362	2407	2452	2497	2543	2588	2633	2678	
1	2723	2769	2814	2859	2904	2949	2994	3040	3085	3130	
2	3175	3220	3265	3310	3356	3401	3446	3491	3536	3581	
3	3626	3671	3716	3762	3807	3852	3897	3942	3987	4032	
4	4077	4122	4167	4212	4257	4302	4347	4392	4437	4482	
5	4527	4572	4617	4662	4707	4752	4797	4842	4887	4932	45
6	4977	5022	5067	5112	5157	5202	5247	5292	5337	5382	
7	5426	5471	5516	5561	5606	5651	5696	5741	5786	5830	
8	5875	5920	5965	6010	6055	6100	6144	6189	6234	6279	
9	6324	6369	6413	6458	6503	6548	6593	6637	6682	6727	
970	6772	6817	6861	6906	6951	6996	7040	7085	7130	7175	
1	7219	7264	7309	7353	7398	7443	7488	7532	7577	7622	
2	7666	7711	7756	7800	7845	7890	7934	7979	8024	8068	
3	8113	8157	8202	8247	8291	8336	8381	8425	8470	8514	
4	8559	8604	8648	8693	8737	8782	8826	8871	8916	8960	
5	9005	9049	9094	9138	9183	9227	9272	9316	9361	9405	
6	9450	9494	9539	9583	9628	9672	9717	9761	9806	9850	
7	9895	9939	9983	0028	0072	0117	0161	0206	0250	0294	
8	990339	0383	0428	0472	0516	0561	0605	0650	0694	0738	
9	0783	0827	0871	0916	0960	1004	1049	1093	1137	1182	
980	1226	1270	1315	1359	1403	1448	1492	1536	1580	1625	
1	1669	1713	1758	1802	1846	1890	1935	1979	2023	2067	
2	2111	2156	2200	2244	2288	2333	2377	2421	2465	2509	
3	2554	2598	2642	2686	2730	2774	2819	2863	2907	2951	
4	2995	3039	3083	3127	3172	3216	3260	3304	3348	3392	
5	3436	3480	3524	3568	3613	3657	3701	3745	3789	3833	
6	3877	3921	3965	4009	4053	4097	4141	4185	4229	4273	
7	4317	4361	4405	4449	4493	4537	4581	4625	4669	4713	
8	4757	4801	4845	4889	4933	4977	5021	5065	5109	5152	44
9	5196	5240	5284	5328	5372	5416	5460	5504	5547	5591	

PROPORTIONAL PARTS.

Diff.	1	2	3	4	5	6	7	8	9
46	4.6	9.2	13.8	18.4	23.0	27.6	32.2	36.8	41.4
45	4.5	9.0	13.5	18.0	22.5	27.0	31.5	36.0	40.5
44	4.4	8.8	13.2	17.6	22.0	26.4	30.8	35.2	39.6
43	4.3	8.6	12.9	17.2	21.5	25.8	30.1	34.4	38.7

No. 990 L. 995.]

[No. 999 L. 999.

N.	0	1	2	3	4	5	6	7	8	9	Diff.
990	995635	5679	5723	5767	5811	5854	5898	5942	5986	6030	
1	6074	6117	6161	6205	6249	6293	6337	6380	6424	6468	44
2	6512	6555	6599	6643	6687	6731	6774	6818	6862	6906	
3	6949	6993	7037	7080	7124	7168	7212	7255	7299	7343	
4	7386	7430	7474	7517	7561	7605	7648	7692	7736	7779	
5	7823	7867	7910	7954	7998	8041	8085	8129	8172	8216	
6	8259	8303	8347	8390	8434	8477	8521	8564	8608	8652	
7	8695	8739	8782	8826	8869	8913	8956	9000	9043	9087	
8	9131	9174	9218	9261	9305	9348	9392	9435	9479	9522	
9	9565	9609	9652	9696	9739	9783	9826	9870	9913	9957	43

## HYPERBOLIC LOGARITHMS.

No.	Log.	No.	Log.	No.	Log.	No.	Log.	No.	Log.
1.01	.0099	1.45	.3716	1.89	.6366	2.33	.8458	2.77	1.0188
1.02	.0198	1.46	.3784	1.90	.6419	2.34	.8502	2.78	1.0225
1.03	.0296	1.47	.3853	1.91	.6471	2.35	.8544	2.79	1.0260
1.04	.0392	1.48	.3920	1.92	.6523	2.36	.8587	2.80	1.0296
1.05	.0488	1.49	.3988	1.93	.6575	2.37	.8629	2.81	1.0332
1.06	.0583	1.50	.4055	1.94	.6627	2.38	.8671	2.82	1.0367
1.07	.0677	1.51	.4121	1.95	.6678	2.39	.8713	2.83	1.0403
1.08	.0770	1.52	.4187	1.96	.6729	2.40	.8755	2.84	1.0438
1.09	.0862	1.53	.4253	1.97	.6780	2.41	.8796	2.85	1.0473
1.10	.0953	1.54	.4318	1.98	.6831	2.42	.8838	2.86	1.0508
1.11	.1044	1.55	.4383	1.99	.6881	2.43	.8879	2.87	1.0543
1.12	.1133	1.56	.4447	2.00	.6931	2.44	.8920	2.88	1.0578
1.13	.1222	1.57	.4511	2.01	.6981	2.45	.8961	2.89	1.0613
1.14	.1310	1.58	.4574	2.02	.7031	2.46	.9002	2.90	1.0647
1.15	.1398	1.59	.4637	2.03	.7080	2.47	.9042	2.91	1.0682
1.16	.1484	1.60	.4700	2.04	.7129	2.48	.9083	2.92	1.0716
1.17	.1570	1.61	.4762	2.05	.7178	2.49	.9123	2.93	1.0750
1.18	.1655	1.62	.4824	2.06	.7227	2.50	.9163	2.94	1.0784
1.19	.1740	1.63	.4886	2.07	.7275	2.51	.9203	2.95	1.0818
1.20	.1823	1.64	.4947	2.08	.7324	2.52	.9243	2.96	1.0852
1.21	.1906	1.65	.5008	2.09	.7372	2.53	.9282	2.97	1.0886
1.22	.1988	1.66	.5068	2.10	.7419	2.54	.9322	2.98	1.0919
1.23	.2070	1.67	.5128	2.11	.7467	2.55	.9361	2.99	1.0953
1.24	.2151	1.68	.5188	2.12	.7514	2.56	.9400	3.00	1.0986
1.25	.2231	1.69	.5247	2.13	.7561	2.57	.9439	3.01	1.1019
1.26	.2311	1.70	.5306	2.14	.7608	2.58	.9478	3.02	1.1056
1.27	.2390	1.71	.5365	2.15	.7655	2.59	.9517	3.03	1.1081
1.28	.2469	1.72	.5423	2.16	.7701	2.60	.9555	3.04	1.1113
1.29	.2546	1.73	.5481	2.17	.7747	2.61	.9594	3.05	1.1154
1.30	.2624	1.74	.5539	2.18	.7793	2.62	.9632	3.06	1.1187
1.31	.2700	1.75	.5596	2.19	.7839	2.63	.9670	3.07	1.1219
1.32	.2776	1.76	.5653	2.20	.7885	2.64	.9708	3.08	1.1246
1.33	.2852	1.77	.5710	2.21	.7930	2.65	.9746	3.09	1.1284
1.34	.2927	1.78	.5766	2.22	.7975	2.66	.9783	3.10	1.1312
1.35	.3001	1.79	.5822	2.23	.8020	2.67	.9821	3.11	1.1349
1.36	.3075	1.80	.5878	2.24	.8065	2.68	.9858	3.12	1.1378
1.37	.3148	1.81	.5933	2.25	.8109	2.69	.9895	3.13	1.1410
1.38	.3221	1.82	.5988	2.26	.8154	2.70	.9933	3.14	1.1442
1.39	.3293	1.83	.6043	2.27	.8198	2.71	.9969	3.15	1.1474
1.40	.3365	1.84	.6098	2.28	.8242	2.72	1.0006	3.16	1.1506
1.41	.3436	1.85	.6152	2.29	.8286	2.73	1.0043	3.17	1.1537
1.42	.3507	1.86	.6206	2.30	.8329	2.74	1.0080	3.18	1.1569
1.43	.3577	1.87	.6259	2.31	.8372	2.75	1.0116	3.19	1.1600
1.44	.3646	1.88	.6313	2.32	.8416	2.76	1.0152	3.20	1.1632

No.	Log.	No.	Log.	No.	Log.	No.	Log.	No.	Log.
3.21	1.1663	3.87	1.3533	4.53	1.5107	5.19	1.6467	5.85	1.7664
3.22	1.1694	3.88	1.3558	4.54	1.5129	5.20	1.6487	5.86	1.7681
3.23	1.1725	3.89	1.3584	4.55	1.5151	5.21	1.6506	5.87	1.7699
3.24	1.1756	3.90	1.3610	4.56	1.5173	5.22	1.6525	5.88	1.7716
3.25	1.1787	3.91	1.3635	4.57	1.5195	5.23	1.6544	5.89	1.7733
3.26	1.1817	3.92	1.3661	4.58	1.5217	5.24	1.6563	5.90	1.7750
3.27	1.1848	3.93	1.3686	4.59	1.5239	5.25	1.6582	5.91	1.7766
3.28	1.1878	3.94	1.3712	4.60	1.5261	5.26	1.6601	5.92	1.7783
3.29	1.1909	3.95	1.3737	4.61	1.5282	5.27	1.6620	5.93	1.7800
3.30	1.1939	3.96	1.3762	4.62	1.5304	5.28	1.6639	5.94	1.7817
3.31	1.1969	3.97	1.3788	4.63	1.5326	5.29	1.6658	5.95	1.7834
3.32	1.1999	3.98	1.3813	4.64	1.5347	5.30	1.6677	5.96	1.7851
3.33	1.2030	3.99	1.3838	4.65	1.5369	5.31	1.6696	5.97	1.7867
3.34	1.2060	4.00	1.3863	4.66	1.5390	5.32	1.6715	5.98	1.7884
3.35	1.2090	4.01	1.3888	4.67	1.5412	5.33	1.6734	5.99	1.7901
3.36	1.2119	4.02	1.3913	4.68	1.5433	5.34	1.6752	6.00	1.7918
3.37	1.2149	4.03	1.3938	4.69	1.5454	5.35	1.6771	6.01	1.7934
3.38	1.2179	4.04	1.3962	4.70	1.5476	5.36	1.6790	6.02	1.7951
3.39	1.2208	4.05	1.3987	4.71	1.5497	5.37	1.6808	6.03	1.7967
3.40	1.2238	4.06	1.4012	4.72	1.5518	5.38	1.6827	6.04	1.7984
3.41	1.2267	4.07	1.4036	4.73	1.5539	5.39	1.6845	6.05	1.8001
3.42	1.2296	4.08	1.4061	4.74	1.5560	5.40	1.6864	6.06	1.8017
3.43	1.2326	4.09	1.4085	4.75	1.5581	5.41	1.6882	6.07	1.8034
3.44	1.2355	4.10	1.4110	4.76	1.5602	5.42	1.6901	6.08	1.8050
3.45	1.2384	4.11	1.4134	4.77	1.5623	5.43	1.6919	6.09	1.8066
3.46	1.2413	4.12	1.4159	4.78	1.5644	5.44	1.6938	6.10	1.8083
3.47	1.2442	4.13	1.4183	4.79	1.5665	5.45	1.6956	6.11	1.8099
3.48	1.2470	4.14	1.4207	4.80	1.5686	5.46	1.6974	6.12	1.8116
3.49	1.2499	4.15	1.4231	4.81	1.5707	5.47	1.6993	6.13	1.8132
3.50	1.2528	4.16	1.4255	4.82	1.5728	5.48	1.7011	6.14	1.8148
3.51	1.2556	4.17	1.4279	4.83	1.5748	5.49	1.7029	6.15	1.8165
3.52	1.2585	4.18	1.4303	4.84	1.5769	5.50	1.7047	6.16	1.8181
3.53	1.2613	4.19	1.4327	4.85	1.5790	5.51	1.7066	6.17	1.8197
3.54	1.2641	4.20	1.4351	4.86	1.5810	5.52	1.7084	6.18	1.8213
3.55	1.2669	4.21	1.4375	4.87	1.5831	5.53	1.7102	6.19	1.8229
3.56	1.2698	4.22	1.4398	4.88	1.5851	5.54	1.7120	6.20	1.8245
3.57	1.2726	4.23	1.4422	4.89	1.5872	5.55	1.7138	6.21	1.8262
3.58	1.2754	4.24	1.4446	4.90	1.5892	5.56	1.7156	6.22	1.8278
3.59	1.2782	4.25	1.4469	4.91	1.5913	5.57	1.7174	6.23	1.8294
3.60	1.2809	4.26	1.4493	4.92	1.5933	5.58	1.7192	6.24	1.8310
3.61	1.2837	4.27	1.4516	4.93	1.5953	5.59	1.7210	6.25	1.8326
3.62	1.2865	4.28	1.4540	4.94	1.5974	5.60	1.7228	6.26	1.8342
3.63	1.2892	4.29	1.4563	4.95	1.5994	5.61	1.7246	6.27	1.8358
3.64	1.2920	4.30	1.4586	4.96	1.6014	5.62	1.7263	6.28	1.8374
3.65	1.2947	4.31	1.4609	4.97	1.6034	5.63	1.7281	6.29	1.8390
3.66	1.2975	4.32	1.4633	4.98	1.6054	5.64	1.7299	6.30	1.8405
3.67	1.3002	4.33	1.4656	4.99	1.6074	5.65	1.7317	6.31	1.8421
3.68	1.3029	4.34	1.4679	5.00	1.6094	5.66	1.7334	6.32	1.8437
3.69	1.3056	4.35	1.4702	5.01	1.6114	5.67	1.7352	6.33	1.8453
3.70	1.3083	4.36	1.4725	5.02	1.6134	5.68	1.7370	6.34	1.8469
3.71	1.3110	4.37	1.4748	5.03	1.6154	5.69	1.7387	6.35	1.8485
3.72	1.3137	4.38	1.4770	5.04	1.6174	5.70	1.7405	6.36	1.8500
3.73	1.3164	4.39	1.4793	5.05	1.6194	5.71	1.7422	6.37	1.8516
3.74	1.3191	4.40	1.4816	5.06	1.6214	5.72	1.7440	6.38	1.8532
3.75	1.3218	4.41	1.4839	5.07	1.6233	5.73	1.7457	6.39	1.8547
3.76	1.3244	4.42	1.4861	5.08	1.6253	5.74	1.7475	6.40	1.8563
3.77	1.3271	4.43	1.4884	5.09	1.6273	5.75	1.7492	6.41	1.8579
3.78	1.3297	4.44	1.4907	5.10	1.6292	5.76	1.7509	6.42	1.8594
3.79	1.3324	4.45	1.4929	5.11	1.6312	5.77	1.7527	6.43	1.8610
3.80	1.3350	4.46	1.4951	5.12	1.6332	5.78	1.7544	6.44	1.8625
3.81	1.3376	4.47	1.4974	5.13	1.6351	5.79	1.7561	6.45	1.8641
3.82	1.3403	4.48	1.4996	5.14	1.6371	5.80	1.7579	6.46	1.8656
3.83	1.3429	4.49	1.5019	5.15	1.6390	5.81	1.7596	6.47	1.8672
3.84	1.3455	4.50	1.5041	5.16	1.6409	5.82	1.7613	6.48	1.8687
3.85	1.3481	4.51	1.5063	5.17	1.6429	5.83	1.7630	6.49	1.8703
3.86	1.3507	4.52	1.5085	5.18	1.6448	5.84	1.7647	6.50	1.8718



No.	Log.	No.	Log.	No.	Log.	No.	Log.	No	Log.
6.51	1.8733	7.15	1.9671	7.79	2.0528	8.66	2.1587	9.94	2.2966
6.52	1.8749	7.16	1.9685	7.80	2.0541	8.68	2.1610	9.96	2.2986
6.53	1.8764	7.17	1.9699	7.81	2.0554	8.70	2.1633	9.98	2.3006
6.54	1.8779	7.18	1.9713	7.82	2.0567	8.72	2.1656	10.00	2.3026
6.55	1.8795	7.19	1.9727	7.83	2.0580	8.74	2.1679	10.25	2.3279
6.56	1.8810	7.20	1.9741	7.84	2.0592	8.76	2.1702	10.50	2.3513
6.57	1.8825	7.21	1.9754	7.85	2.0605	8.78	2.1725	10.75	2.3749
6.58	1.8840	7.22	1.9769	7.86	2.0618	8.80	2.1748	11.00	2.3979
6.59	1.8856	7.23	1.9782	7.87	2.0631	8.82	2.1770	11.25	2.4201
6.60	1.8871	7.24	1.9796	7.88	2.0643	8.84	2.1793	11.50	2.4430
6.61	1.8886	7.25	1.9810	7.89	2.0656	8.86	2.1815	11.75	2.4636
6.62	1.8901	7.26	1.9824	7.90	2.0669	8.88	2.1838	12.00	2.4849
6.63	1.8916	7.27	1.9838	7.91	2.0681	8.90	2.1861	12.25	2.5052
6.64	1.8931	7.28	1.9851	7.92	2.0694	8.92	2.1883	12.50	2.5262
6.65	1.8946	7.29	1.9865	7.93	2.0707	8.94	2.1905	12.75	2.5455
6.66	1.8961	7.30	1.9879	7.94	2.0719	8.96	2.1928	13.00	2.5649
6.67	1.8976	7.31	1.9892	7.95	2.0732	8.98	2.1950	13.25	2.5840
6.68	1.8991	7.32	1.9906	7.96	2.0744	8.99	2.1972	13.50	2.6027
6.69	1.9006	7.33	1.9920	7.97	2.0757	9.02	2.1994	13.75	2.6211
6.70	1.9021	7.34	1.9933	7.98	2.0769	9.04	2.2017	14.00	2.6391
6.71	1.9036	7.35	1.9947	7.99	2.0782	9.06	2.2039	14.25	2.6567
6.72	1.9051	7.36	1.9961	8.00	2.0794	9.03	2.2061	14.50	2.6740
6.73	1.9066	7.37	1.9974	8.01	2.0807	9.10	2.2083	14.75	2.6913
6.74	1.9081	7.38	1.9988	8.02	2.0819	9.12	2.2105	15.00	2.7081
6.75	1.9095	7.39	2.0001	8.03	2.0832	9.14	2.2127	15.50	2.7408
6.76	1.9110	7.40	2.0015	8.04	2.0844	9.16	2.2148	16.00	2.7726
6.77	1.9125	7.41	2.0028	8.05	2.0857	9.18	2.2170	16.50	2.8034
6.78	1.9140	7.42	2.0041	8.06	2.0869	9.20	2.2192	17.00	2.8332
6.79	1.9155	7.43	2.0055	8.07	2.0882	9.22	2.2214	17.50	2.8621
6.80	1.9169	7.44	2.0069	8.08	2.0894	9.24	2.2235	18.00	2.8904
6.81	1.9184	7.45	2.0082	8.09	2.0906	9.26	2.2257	18.50	2.9178
6.82	1.9199	7.46	2.0096	8.10	2.0919	9.28	2.2279	19.00	2.9444
6.83	1.9213	7.47	2.0108	8.11	2.0931	9.30	2.2300	19.50	2.9703
6.84	1.9228	7.48	2.0122	8.12	2.0943	9.32	2.2322	20.00	2.9957
6.85	1.9242	7.49	2.0136	8.13	2.0956	9.34	2.2343	21	3.0445
6.86	1.9257	7.50	2.0149	8.14	2.0968	9.36	2.2364	22	3.0910
6.87	1.9272	7.51	2.0162	8.15	2.0980	9.38	2.2386	23	3.1355
6.88	1.9286	7.52	2.0176	8.16	2.0992	9.40	2.2407	24	3.1781
6.89	1.9301	7.53	2.0189	8.17	2.1005	9.42	2.2428	25	3.2189
6.90	1.9315	7.54	2.0202	8.18	2.1017	9.44	2.2450	26	3.2581
6.91	1.9330	7.55	2.0215	8.19	2.1029	9.46	2.2471	27	3.2958
6.92	1.9344	7.56	2.0229	8.20	2.1041	9.48	2.2492	28	3.3322
6.93	1.9359	7.57	2.0242	8.22	2.1066	9.50	2.2513	29	3.3673
6.94	1.9373	7.58	2.0255	8.24	2.1090	9.52	2.2534	30	3.4012
6.95	1.9387	7.59	2.0268	8.26	2.1114	9.54	2.2555	31	3.4340
6.96	1.9402	7.60	2.0281	8.28	2.1138	9.56	2.2576	32	3.4657
6.97	1.9416	7.61	2.0295	8.30	2.1163	9.58	2.2597	33	3.4965
6.98	1.9430	7.62	2.0308	8.32	2.1187	9.60	2.2618	34	3.5263
6.99	1.9445	7.63	2.0321	8.34	2.1211	9.62	2.2638	35	3.5553
7.00	1.9459	7.64	2.0334	8.36	2.1235	9.64	2.2659	36	3.5835
7.01	1.9473	7.65	2.0347	8.38	2.1258	9.66	2.2680	37	3.6109
7.02	1.9488	7.66	2.0360	8.40	2.1282	9.68	2.2701	38	3.6376
7.03	1.9502	7.67	2.0373	8.42	2.1306	9.70	2.2721	39	3.6636
7.04	1.9516	7.68	2.0386	8.44	2.1330	9.72	2.2742	40	3.6889
7.05	1.9530	7.69	2.0399	8.46	2.1353	9.74	2.2762	41	3.7136
7.06	1.9544	7.70	2.0412	8.48	2.1377	9.76	2.2783	42	3.7377
7.07	1.9559	7.71	2.0425	8.50	2.1401	9.78	2.2803	43	3.7612
7.08	1.9573	7.72	2.0438	8.52	2.1424	9.80	2.2824	44	3.7842
7.09	1.9587	7.73	2.0451	8.54	2.1448	9.82	2.2844	45	3.8067
7.10	1.9601	7.74	2.0464	8.56	2.1471	9.84	2.2865	46	3.8286
7.11	1.9615	7.75	2.0477	8.58	2.1494	9.86	2.2885	47	3.8501
7.12	1.9629	7.76	2.0490	8.60	2.1518	9.88	2.2905	48	3.8712
7.13	1.9643	7.77	2.0503	8.62	2.1541	9.90	2.2925	49	3.8918
7.14	1.9657	7.78	2.0516	8.64	2.1564	9.92	2.2946	50	3.9120



LOGARITHMIC SINES, ETC.

Deg.	Sine.	Cosec.	Versin.	Tangent	Cotan.	Covers.	Secant.	Cosine.	Deg.
0	In.Neg.	Infinite.	In.Neg.	In.Neg.	Infinite.	10.00000	10.00000	10.00000	90
1	8.24186	11.75814	6.18271	8.24192	11.75808	9.99235	10.00007	9.99993	89
2	8.54282	11.45718	6.78474	8.54308	11.45692	9.98457	10.00026	9.99974	88
3	8.71880	11.28120	7.13687	8.71940	11.28060	9.97665	10.00060	9.99940	87
4	8.84358	11.15642	7.38667	8.84464	11.15536	9.96860	10.00106	9.99894	86
5	8.94030	11.05970	7.58039	8.94195	11.05805	9.96040	10.00166	9.99834	85
6	9.01923	10.98077	7.73863	9.02162	10.97838	9.95205	10.00239	9.99761	84
7	9.08589	10.91411	7.87238	9.08914	10.91086	9.94356	10.00325	9.99675	83
8	9.14356	10.85644	7.98820	9.14780	10.85220	9.93492	10.00425	9.99575	82
9	9.19433	10.80567	8.09032	9.19971	10.80029	9.92612	10.00538	9.99462	81
10	9.23967	10.76033	8.18162	9.24632	10.75368	9.91717	10.00665	9.99335	80
11	9.28060	10.71940	8.26418	9.28865	10.71135	9.90805	10.00805	9.99195	79
12	9.31788	10.68212	8.33950	9.32747	10.67253	9.89877	10.00960	9.99040	78
13	9.35209	10.64791	8.40375	9.36336	10.63664	9.88933	10.01128	9.98872	77
14	9.38368	10.61632	8.47282	9.39677	10.60323	9.87971	10.01310	9.98690	76
15	9.41300	10.58700	8.53243	9.42805	10.57195	9.86992	10.01506	9.98494	75
16	9.44034	10.55966	8.58814	9.45750	10.54250	9.85996	10.01716	9.98284	74
17	9.46594	10.53406	8.64043	9.48534	10.51466	9.84981	10.01940	9.98060	73
18	9.48998	10.51002	8.68969	9.51178	10.48822	9.83947	10.02179	9.97821	72
19	9.51264	10.48736	8.73625	9.53697	10.46303	9.82894	10.02433	9.97567	71
20	9.53405	10.46595	8.78037	9.56107	10.43893	9.81821	10.02701	9.97299	70
21	9.55433	10.44567	8.82230	9.58418	10.41582	9.80729	10.02985	9.97015	69
22	9.57358	10.42642	8.86223	9.60641	10.39359	9.79615	10.03283	9.96717	68
23	9.59188	10.40812	8.90034	9.62785	10.37215	9.78481	10.03597	9.96403	67
24	9.60931	10.39069	8.93679	9.64858	10.35142	9.77325	10.03927	9.96073	66
25	9.62595	10.37405	8.97170	9.66867	10.33133	9.76146	10.04272	9.95728	65
26	9.64184	10.35816	9.00521	9.68818	10.31182	9.74945	10.04634	9.95366	64
27	9.65705	10.34295	9.03740	9.70717	10.29283	9.73720	10.05012	9.94988	63
28	9.67161	10.32839	9.06838	9.72567	10.27433	9.72471	10.05407	9.94593	62
29	9.68557	10.31443	9.09823	9.74375	10.25625	9.71197	10.05818	9.94182	61
30	9.69897	10.30103	9.12702	9.76144	10.23856	9.69897	10.06247	9.93753	60
31	9.71184	10.28816	9.15483	9.77877	10.22123	9.68571	10.06693	9.93307	59
32	9.72421	10.27579	9.18171	9.79579	10.20421	9.67217	10.07158	9.92842	58
33	9.73611	10.26389	9.20771	9.81252	10.18748	9.65836	10.07641	9.92359	57
34	9.74756	10.25244	9.23290	9.82899	10.17101	9.64425	10.08143	9.91857	56
35	9.75859	10.24141	9.25731	9.84523	10.15477	9.62984	10.08664	9.91336	55
36	9.76922	10.23078	9.28099	9.86126	10.13874	9.61512	10.09204	9.90796	54
37	9.77946	10.22054	9.30398	9.87711	10.12289	9.60008	10.09765	9.90235	53
38	9.78934	10.21066	9.32631	9.89281	10.10719	9.58471	10.10347	9.89653	52
39	9.79887	10.20113	9.34802	9.90837	10.09163	9.56900	10.10950	9.89050	51
40	9.80807	10.19193	9.36913	9.92381	10.07619	9.55293	10.11575	9.88425	50
41	9.81694	10.18306	9.38968	9.93916	10.06084	9.53648	10.12222	9.87778	49
42	9.82551	10.17449	9.40969	9.95444	10.04556	9.51966	10.12893	9.87107	48
43	9.83378	10.16622	9.42918	9.96966	10.03034	9.50243	10.13587	9.86413	47
44	9.84177	10.15823	9.44818	9.98484	10.01516	9.48479	10.14307	9.85693	46
45	9.84949	10.15052	9.46671	10.00000	10.00000	9.46671	10.15052	9.84949	45
	Cosine.	Secant.	Covers.	Cotan.	Tangent	Versin.	Cosec.	Sine.	

From 45° to 90° read from bottom of table upwards.

## Four-place Logarithms of Numbers to 1000.

For six-place logarithms of numbers to 10,000, see pp. 137 to 164.

No.	0	1	2	3	4	5	6	7	8	9	No.
<b>0</b>		0000	3010	4771	6021	6990	7782	8451	9031	9542	<b>0</b>
	0000	0414	0792	1139	1461	1761	2041	2304	2553	2788	<b>1</b>
2	3010	3222	3424	3617	3802	3979	4150	4314	4472	4624	2
3	4771	4914	5052	5185	5315	5441	5563	5682	5798	5911	3
4	6021	6128	6232	6335	6435	6532	6628	6721	6812	6902	4
5	6990	7076	7160	7243	7324	7404	7482	7559	7634	7709	5
6	7782	7853	7924	7993	8062	8129	8195	8261	8325	8388	6
7	8451	8513	8573	8633	8692	8751	8808	8865	8921	8976	7
8	9031	9085	9138	9191	9243	9294	9345	9395	9445	9494	8
9	9542	9590	9638	9685	9731	9777	9823	9868	9912	9956	9
<b>10</b>	0000	0043	0086	0128	0170	0212	0253	0294	0334	0374	<b>10</b>
11	0414	0453	0492	0531	0569	0607	0645	0682	0719	0755	11
12	0792	0828	0864	0899	0934	0969	1004	1038	1072	1106	12
13	1139	1173	1206	1239	1271	1303	1335	1367	1399	1430	13
14	1461	1492	1523	1553	1584	1614	1644	1673	1703	1732	14
15	1761	1790	1818	1847	1875	1903	1931	1959	1987	2014	15
16	2041	2068	2095	2122	2148	2175	2201	2227	2253	2279	16
17	2304	2330	2355	2380	2405	2430	2455	2480	2504	2529	17
18	2553	2577	2601	2625	2648	2672	2695	2718	2742	2765	18
19	2788	2810	2833	2856	2878	2900	2923	2945	2967	2989	19
<b>20</b>	3010	3032	3054	3075	3096	3118	3139	3160	3181	3201	<b>20</b>
21	3222	3243	3263	3284	3304	3324	3345	3365	3385	3404	21
22	3424	3444	3464	3483	3502	3522	3541	3560	3579	3598	22
23	3617	3636	3655	3674	3692	3711	3729	3747	3766	3784	23
24	3802	3820	3838	3856	3874	3892	3909	3927	3945	3962	24
25	3979	3997	4014	4031	4048	4065	4082	4099	4116	4133	25
26	4150	4166	4183	4200	4216	4232	4249	4265	4281	4298	26
27	4314	4330	4346	4362	4378	4393	4409	4425	4440	4456	27
28	4472	4487	4502	4518	4533	4548	4564	4579	4594	4609	28
29	4624	4639	4654	4669	4683	4698	4713	4728	4742	4757	29
<b>30</b>	4771	4786	4800	4814	4829	4843	4857	4871	4886	4900	<b>30</b>
31	4914	4928	4942	4955	4969	4983	4997	5011	5024	5038	31
32	5052	5065	5079	5092	5105	5119	5132	5145	5159	5172	32
33	5185	5198	5211	5224	5237	5250	5263	5276	5289	5302	33
34	5315	5328	5340	5353	5366	5378	5391	5403	5416	5428	34
35	5441	5453	5465	5478	5490	5502	5515	5527	5539	5551	35
36	5563	5575	5587	5599	5611	5623	5635	5647	5658	5670	36
37	5682	5694	5705	5717	5729	5740	5752	5763	5775	5786	37
38	5798	5809	5821	5832	5843	5855	5866	5877	5888	5899	38
39	5911	5922	5933	5944	5955	5966	5977	5988	5999	6010	39
<b>40</b>	6021	6031	6042	6053	6064	6075	6085	6096	6107	6117	<b>40</b>
41	6128	6138	6149	6160	6170	6180	6191	6201	6212	6222	41
42	6232	6243	6253	6263	6274	6284	6294	6304	6314	6325	42
43	6335	6345	6355	6365	6375	6385	6395	6405	6415	6425	43
44	6435	6444	6454	6464	6474	6484	6493	6503	6513	6522	44
45	6532	6542	6551	6561	6571	6580	6590	6599	6609	6618	45
46	6628	6637	6646	6656	6665	6675	6684	6693	6702	6712	46
47	6721	6730	6739	6749	6758	6767	6776	6785	6794	6803	47
48	6812	6821	6830	6839	6848	6857	6866	6875	6884	6893	48
49	6902	6911	6920	6928	6937	6946	6955	6964	6972	6981	49
<b>50</b>	6990	6998	7007	7016	7024	7033	7042	7050	7059	7067	<b>50</b>

Four-place Logarithms of Numbers to 1000.

For six-place logarithms of numbers to 10,000, see pp. 137 to 164.

No.	0	1	2	3	4	5	6	7	8	9	No.
<b>50</b>	6990	6998	7007	7016	7024	7033	7042	7050	7059	7067	<b>50</b>
51	7076	7084	7093	7101	7110	7118	7126	7135	7143	7152	51
52	7160	7168	7177	7185	7193	7202	7210	7218	7226	7235	52
53	7243	7251	7259	7267	7275	7284	7292	7300	7308	7316	53
54	7324	7332	7340	7348	7356	7364	7372	7380	7388	7396	54
55	7404	7412	7419	7427	7435	7443	7451	7459	7466	7474	55
56	7482	7490	7497	7505	7513	7520	7528	7536	7543	7551	56
57	7559	7566	7574	7582	7589	7597	7604	7612	7619	7627	57
58	7634	7642	7649	7657	7664	7672	7679	7686	7694	7701	58
59	7709	7716	7723	7731	7738	7745	7752	7760	7767	7774	59
<b>60</b>	7782	7789	7796	7803	7810	7818	7825	7832	7839	7846	<b>60</b>
61	7853	7860	7868	7875	7882	7889	7896	7903	7910	7917	61
62	7924	7931	7938	7945	7952	7959	7966	7973	7980	7987	62
63	7993	8000	8007	8014	8021	8028	8035	8041	8048	8055	63
64	8062	8069	8075	8082	8089	8096	8102	8109	8116	8122	64
65	8129	8136	8142	8149	8156	8162	8169	8176	8182	8189	65
66	8195	8202	8209	8215	8222	8228	8235	8241	8248	8254	66
67	8261	8267	8274	8280	8287	8293	8299	8306	8312	8319	67
68	8325	8331	8338	8344	8351	8357	8363	8370	8376	8382	68
69	8388	8395	8401	8407	8414	8420	8426	8432	8439	8445	69
<b>70</b>	8451	8457	8463	8470	8476	8482	8488	8494	8500	8506	<b>70</b>
71	8513	8519	8525	8531	8537	8543	8549	8555	8561	8567	71
72	8573	8579	8585	8591	8597	8603	8609	8615	8621	8627	72
73	8633	8639	8645	8651	8657	8663	8669	8675	8681	8686	73
74	8692	8698	8704	8710	8716	8722	8727	8733	8739	8745	74
75	8751	8756	8762	8768	8774	8779	8785	8791	8797	8802	75
76	8808	8814	8820	8825	8831	8837	8842	8848	8854	8859	76
77	8865	8871	8876	8882	8887	8893	8899	8904	8910	8915	77
78	8921	8927	8932	8938	8943	8949	8954	8960	8965	8971	78
79	8976	8982	8987	8993	8998	9004	9009	9015	9020	9025	79
<b>80</b>	9031	9036	9042	9047	9053	9058	9063	9069	9074	9079	<b>80</b>
81	9085	9090	9096	9101	9106	9112	9117	9122	9128	9133	81
82	9138	9143	9149	9154	9159	9165	9170	9175	9180	9186	82
83	9191	9196	9201	9206	9212	9217	9222	9227	9232	9238	83
84	9243	9248	9253	9258	9263	9269	9274	9279	9284	9289	84
85	9294	9299	9304	9309	9315	9320	9325	9330	9335	9340	85
86	9345	9350	9355	9360	9365	9370	9375	9380	9385	9390	86
87	9395	9400	9405	9410	9415	9420	9425	9430	9435	9440	87
88	9445	9450	9455	9460	9465	9469	9474	9479	9484	9489	88
89	9494	9499	9504	9509	9513	9518	9523	9528	9533	9538	89
<b>90</b>	9542	9547	9552	9557	9562	9566	9571	9576	9581	9586	<b>90</b>
91	9590	9595	9600	9605	9609	9614	9619	9624	9628	9633	91
92	9638	9643	9647	9652	9657	9661	9666	9671	9675	9680	92
93	9685	9689	9694	9699	9703	9708	9713	9717	9722	9727	93
94	9731	9736	9741	9745	9750	9754	9759	9764	9768	9773	94
95	9777	9782	9786	9791	9795	9800	9805	9809	9814	9818	95
96	9823	9827	9832	9836	9841	9845	9850	9854	9859	9863	96
97	9868	9872	9877	9881	9886	9890	9894	9899	9903	9908	97
98	9912	9917	9921	9926	9930	9934	9939	9943	9948	9952	98
99	9956	9961	9965	9969	9974	9978	9983	9987	9991	9996	99
<b>100</b>	0000	0004	0009	0013	0017	0022	0026	0030	0035	0039	<b>100</b>



NATURAL TRIGONOMETRICAL FUNCTIONS.

•	M.	Sine.	Co-Vers.	Cosec.	Tang.	Cotan.	Se-cant.	Ver. Sin.	Cosine.	°	M.
0	0	.00000	1.0000	Infinite	.00000	Infinite	1.0000	.00000	1.0000	90	0
	15	.00436	.99564	229.18	.00436	229.18	1.0000	.00001	.99999		45
	30	.00873	.99127	114.59	.00873	114.59	1.0000	.00004	.99996		30
	45	.01309	.98691	76.397	.01309	76.390	1.0001	.00009	.99991		15
1	0	.01745	.98255	57.299	.01745	57.290	1.0001	.00015	.99985	89	0
	15	.02181	.97819	45.840	.02182	45.829	1.0002	.00024	.99976		45
	30	.02618	.97382	38.202	.02618	38.188	1.0003	.00034	.99966		30
	45	.03054	.96946	32.746	.03055	32.730	1.0005	.00047	.99953		15
2	0	.03490	.96510	28.654	.03492	28.636	1.0006	.00061	.99939	88	0
	15	.03926	.96074	25.471	.03929	25.452	1.0008	.00077	.99923		45
	30	.04362	.95638	22.926	.04366	22.904	1.0009	.00095	.99905		30
	45	.04798	.95202	20.843	.04803	20.819	1.0011	.00115	.99885		15
3	0	.05234	.94766	19.107	.05241	19.081	1.0014	.00137	.99863	87	0
	15	.05669	.94331	17.639	.05678	17.611	1.0016	.00161	.99839		45
	30	.06105	.93895	16.380	.06116	16.350	1.0019	.00187	.99813		30
	45	.06540	.93460	15.290	.06554	15.257	1.0021	.00214	.99786		15
4	0	.06976	.93024	14.336	.06993	14.301	1.0024	.00244	.99756	86	0
	15	.07411	.92589	13.494	.07431	13.457	1.0028	.00275	.99725		45
	30	.07846	.92154	12.745	.07870	12.706	1.0031	.00308	.99692		30
	45	.08281	.91719	12.076	.08309	12.035	1.0034	.00343	.99656		15
5	0	.08716	.91284	11.474	.08749	11.430	1.0038	.00381	.99619	85	0
	15	.09150	.90850	10.929	.09189	10.883	1.0042	.00420	.99580		45
	30	.09585	.90415	10.433	.09629	10.385	1.0046	.00460	.99540		30
	45	.10019	.89981	9.9812	.10069	9.9310	1.0051	.00503	.99497		15
6	0	.10453	.89547	9.5668	.10510	9.5144	1.0055	.00548	.99452	84	0
	15	.10887	.89113	9.1855	.10952	9.1309	1.0060	.00594	.99406		45
	30	.11320	.88680	8.8337	.11393	8.7769	1.0065	.00643	.99357		30
	45	.11754	.88246	8.5079	.11836	8.4490	1.0070	.00693	.99307		15
7	0	.12187	.87813	8.2055	.12278	8.1443	1.0075	.00745	.99255	83	0
	15	.12620	.87380	7.9240	.12722	7.8606	1.0081	.00800	.99200		45
	30	.13053	.86947	7.6613	.13165	7.5958	1.0086	.00856	.99144		30
	45	.13485	.86515	7.4156	.13609	7.3479	1.0092	.00913	.99086		15
8	0	.13917	.86083	7.1853	.14054	7.1154	1.0098	.00973	.99027	82	0
	15	.14349	.85651	6.9690	.14499	6.8969	1.0105	.01035	.98965		45
	30	.14781	.85219	6.7655	.14945	6.6912	1.0111	.01098	.98902		30
	45	.15212	.84788	6.5736	.15391	6.4971	1.0118	.01164	.98836		15
9	0	.15643	.84357	6.3924	.15838	6.3138	1.0125	.01231	.98769	81	0
	15	.16074	.83926	6.2211	.16286	6.1402	1.0132	.01300	.98700		45
	30	.16505	.83495	6.0589	.16734	5.9758	1.0139	.01371	.98629		30
	45	.16935	.83065	5.9049	.17183	5.8197	1.0147	.01444	.98556		15
10	0	.17365	.82635	5.7588	.17633	5.6713	1.0154	.01519	.98481	80	0
	15	.17794	.82206	5.6198	.18083	5.5301	1.0162	.01596	.98404		45
	30	.18224	.81776	5.4874	.18534	5.3955	1.0170	.01675	.98325		30
	45	.18652	.81348	5.3612	.18986	5.2672	1.0179	.01755	.98245		15
11	0	.19081	.80919	5.2408	.19438	5.1446	1.0187	.01837	.98163	79	0
	15	.19509	.80491	5.1258	.19891	5.0273	1.0196	.01921	.98079		45
	30	.19937	.80063	5.0158	.20345	4.9152	1.0205	.02008	.97992		30
	45	.20364	.79636	4.9106	.20800	4.8077	1.0214	.02095	.97905		15
12	0	.20791	.79209	4.8097	.21256	4.7046	1.0223	.02185	.97815	78	0
	15	.21218	.78782	4.7130	.21712	4.6057	1.0233	.02277	.97723		45
	30	.21644	.78356	4.6202	.22169	4.5107	1.0243	.02370	.97630		30
	45	.22070	.77930	4.5311	.22628	4.4194	1.0253	.02466	.97534		15
13	0	.22495	.77505	4.4454	.23087	4.3315	1.0263	.02563	.97437	77	0
	15	.22920	.77080	4.3630	.23547	4.2468	1.0273	.02662	.97338		45
	30	.23345	.76655	4.2837	.24008	4.1653	1.0284	.02763	.97237		30
	45	.23769	.76231	4.2072	.24470	4.0867	1.0295	.02866	.97134		15
14	0	.24192	.75808	4.1336	.24933	4.0108	1.0306	.02970	.97030	76	0
	15	.24615	.75385	4.0625	.25397	3.9375	1.0317	.03077	.96923		45
	30	.25038	.74962	3.9939	.25862	3.8667	1.0329	.03185	.96815		30
	45	.25460	.74540	3.9277	.26328	3.7983	1.0341	.03295	.96705		15
15	0	.25882	.74118	3.8637	.26795	3.7320	1.0353	.03407	.96593	75	0

From 75° to 90° read from bottom of table upwards.



°	M.	Sine.	Co-Vers.	Cosec.	Tang.	Cotan.	Secant.	Ver. Sin.	Cosine.		
15	0	.25882	.74118	3.8637	.26795	3.7320	1.0353	.03407	.96593	75	0
	15	.26303	.73697	3.8018	.27263	3.6680	1.0365	.03521	.96479		45
	30	.26724	.73276	3.7420	.27732	3.6059	1.0377	.03637	.96363		30
	45	.27144	.72856	3.6840	.28203	3.5457	1.0390	.03754	.96246		15
16	0	.27564	.72436	3.6280	.28674	3.4874	1.0403	.03874	.96126	74	0
	15	.27983	.72017	3.5736	.29147	3.4308	1.0416	.03995	.96005		45
	30	.28402	.71598	3.5209	.29621	3.3759	1.0429	.04118	.95882		30
	45	.28820	.71180	3.4699	.30096	3.3226	1.0443	.04243	.95757		15
17	0	.29237	.70763	3.4203	.30573	3.2709	1.0457	.04370	.95630	73	0
	15	.29654	.70346	3.3722	.31051	3.2205	1.0471	.04498	.95502		45
	30	.30070	.69929	3.3255	.31530	3.1716	1.0485	.04628	.95372		30
	45	.30486	.69514	3.2801	.32010	3.1240	1.0500	.04760	.95240		15
18	0	.30902	.69098	3.2361	.32492	3.0777	1.0515	.04894	.95106	72	0
	15	.31316	.68684	3.1932	.32975	3.0326	1.0530	.05030	.94970		45
	30	.31730	.68270	3.1515	.33459	2.9887	1.0545	.05168	.94832		30
	45	.32144	.67856	3.1110	.33945	2.9459	1.0560	.05307	.94693		15
19	0	.32557	.67443	3.0715	.34433	2.9042	1.0576	.05448	.94552	71	0
	15	.32969	.67031	3.0331	.34921	2.8636	1.0592	.05591	.94409		45
	30	.33381	.66619	2.9957	.35412	2.8239	1.0608	.05736	.94264		30
	45	.33792	.66208	2.9593	.35904	2.7852	1.0625	.05882	.94118		15
20	0	.34202	.65798	2.9238	.36397	2.7475	1.0642	.06031	.93969	70	0
	15	.34612	.65388	2.8892	.36892	2.7106	1.0659	.06181	.93819		45
	30	.35021	.64979	2.8554	.37388	2.6746	1.0676	.06333	.93667		30
	45	.35429	.64571	2.8225	.37887	2.6395	1.0694	.06486	.93514		15
21	0	.35837	.64163	2.7904	.38386	2.6051	1.0711	.06642	.93358	69	0
	15	.36244	.63756	2.7591	.38888	2.5715	1.0729	.06799	.93201		45
	30	.36650	.63350	2.7285	.39391	2.5386	1.0748	.06958	.93042		30
	45	.37056	.62944	2.6986	.39896	2.5065	1.0766	.07119	.92881		15
22	0	.37461	.62539	2.6695	.40403	2.4751	1.0785	.07282	.92718	68	0
	15	.37865	.62135	2.6410	.40911	2.4443	1.0804	.07446	.92554		45
	30	.38268	.61732	2.6131	.41421	2.4142	1.0824	.07612	.92388		30
	45	.38671	.61329	2.5859	.41933	2.3847	1.0844	.07780	.92220		15
23	0	.39073	.60927	2.5593	.42447	2.3559	1.0864	.07950	.92050	67	0
	15	.39474	.60526	2.5333	.42963	2.3276	1.0884	.08121	.91879		45
	30	.39875	.60125	2.5078	.43481	2.2993	1.0904	.08294	.91706		30
	45	.40275	.59725	2.4829	.44001	2.2727	1.0925	.08469	.91531		15
24	0	.40674	.59326	2.4586	.44523	2.2460	1.0946	.08645	.91355	66	0
	15	.41072	.58928	2.4348	.45047	2.2199	1.0968	.08824	.91176		45
	30	.41469	.58531	2.4114	.45573	2.1943	1.0989	.09004	.90996		30
	45	.41866	.58134	2.3886	.46101	2.1692	1.1011	.09186	.90814		15
25	0	.42262	.57738	2.3662	.46631	2.1445	1.1034	.09369	.90631	65	0
	15	.42657	.57343	2.3443	.47163	2.1203	1.1056	.09554	.90446		45
	30	.43051	.56949	2.3228	.47697	2.0965	1.1079	.09741	.90259		30
	45	.43445	.56555	2.3018	.48234	2.0732	1.1102	.09930	.90070		15
26	0	.43837	.56163	2.2812	.48773	2.0503	1.1126	.10121	.89879	64	0
	15	.44229	.55771	2.2610	.49314	2.0278	1.1150	.10313	.89687		45
	30	.44620	.55380	2.2412	.49858	2.0057	1.1174	.10507	.89493		30
	45	.45010	.54990	2.2217	.50404	1.9840	1.1198	.10702	.89298		15
27	0	.45399	.54601	2.2027	.50952	1.9626	1.1223	.10899	.89101	63	0
	15	.45787	.54213	2.1840	.51503	1.9416	1.1248	.11098	.88902		45
	30	.46175	.53825	2.1657	.52057	1.9210	1.1274	.11299	.88701		30
	45	.46561	.53439	2.1477	.52612	1.9007	1.1300	.11501	.88499		15
28	0	.46947	.53053	2.1300	.53171	1.8807	1.1326	.11705	.88295	62	0
	15	.47332	.52668	2.1127	.53732	1.8611	1.1352	.11911	.88089		45
	30	.47716	.52284	2.0957	.54295	1.8418	1.1379	.12118	.87882		30
	45	.48099	.51901	2.0790	.54862	1.8228	1.1406	.12327	.87673		15
29	0	.48481	.51519	2.0627	.55431	1.8040	1.1433	.12538	.87462	61	0
	15	.48862	.51138	2.0466	.56003	1.7856	1.1461	.12750	.87250		45
	30	.49242	.50758	2.0308	.56577	1.7675	1.1490	.12964	.87036		30
	45	.49622	.50378	2.0152	.57155	1.7496	1.1518	.13180	.86820		15
30	0	.50000	.50000	2.0000	.57735	1.7320	1.1547	.13397	.86603	60	0

From 60° to 75° read from bottom of table upwards.

°	M.	Sine.	Co-Vers.	Cosec.	Tang.	Cotan.	Secant.	Ver. Sin.	Cosine	°	M.
30	0	.50000	.50000	2.0000	.57735	1.7320	1.1547	.13397	.86603	60	0
	15	.50377	.49623	1.9850	.58318	1.7147	1.1576	.13616	.86384		45
	30	.50754	.49246	1.9703	.58904	1.6977	1.1606	.13837	.86163		30
	45	.51129	.48871	1.9558	.59494	1.6808	1.1636	.14059	.85941		15
31	0	.51504	.48496	1.9416	.60086	1.6643	1.1666	.14283	.85717	59	0
	15	.51877	.48123	1.9276	.60681	1.6479	1.1697	.14509	.85491		45
	30	.52250	.47750	1.9139	.61280	1.6319	1.1728	.14736	.85264		30
	45	.52621	.47379	1.9004	.61882	1.6160	1.1760	.14965	.85035		15
32	0	.52992	.47008	1.8871	.62437	1.6003	1.1792	.15195	.84805	58	0
	15	.53361	.46639	1.8740	.63095	1.5849	1.1824	.15427	.84573		45
	30	.53730	.46270	1.8612	.63707	1.5697	1.1857	.15661	.84339		30
	45	.54097	.45903	1.8485	.64322	1.5547	1.1890	.15896	.84104		15
33	0	.54464	.45536	1.8361	.64941	1.5399	1.1924	.16133	.83867	57	0
	15	.54829	.45171	1.8238	.65563	1.5253	1.1958	.16371	.83629		45
	30	.55194	.44806	1.8118	.66188	1.5108	1.1992	.16611	.83389		30
	45	.55557	.44443	1.7999	.66818	1.4966	1.2027	.16853	.83147		15
34	0	.55919	.44081	1.7883	.67451	1.4826	1.2062	.17096	.82904	56	0
	15	.56280	.43720	1.7768	.68087	1.4687	1.2098	.17341	.82659		45
	30	.56641	.43359	1.7655	.68728	1.4550	1.2134	.17587	.82413		30
	45	.57000	.43000	1.7544	.69372	1.4415	1.2171	.17835	.82165		15
35	0	.57358	.42642	1.7434	.70021	1.4281	1.2208	.18085	.81915	55	0
	15	.57715	.42285	1.7327	.70673	1.4150	1.2245	.18336	.81664		45
	30	.58070	.41930	1.7220	.71329	1.4019	1.2283	.18588	.81412		30
	45	.58425	.41575	1.7116	.71990	1.3891	1.2322	.18843	.81157		15
36	0	.58779	.41221	1.7013	.72654	1.3764	1.2361	.19098	.80902	54	0
	15	.59131	.40869	1.6912	.73323	1.3638	1.2400	.19356	.80644		45
	30	.59482	.40518	1.6812	.73996	1.3514	1.2440	.19614	.80386		30
	45	.59832	.40168	1.6713	.74673	1.3392	1.2480	.19875	.80125		15
37	0	.60181	.39819	1.6616	.75355	1.3270	1.2521	.20136	.79864	53	0
	15	.60529	.39471	1.6521	.76042	1.3151	1.2563	.20400	.79600		45
	30	.60876	.39124	1.6427	.76733	1.3032	1.2605	.20665	.79335		30
	45	.61222	.38778	1.6334	.77428	1.2915	1.2647	.20931	.79069		15
38	0	.61566	.38434	1.6243	.78129	1.2799	1.2690	.21199	.78801	52	0
	15	.61909	.38091	1.6153	.78834	1.2685	1.2734	.21468	.78532		45
	30	.62251	.37749	1.6064	.79543	1.2572	1.2778	.21739	.78261		30
	45	.62592	.37408	1.5976	.80258	1.2460	1.2822	.22012	.77988		15
39	0	.62932	.37068	1.5890	.80978	1.2349	1.2868	.22285	.77715	51	0
	15	.63271	.36729	1.5805	.81703	1.2239	1.2913	.22561	.77439		45
	30	.63608	.36392	1.5721	.82434	1.2131	1.2960	.22838	.77162		30
	45	.63944	.36056	1.5639	.83169	1.2024	1.3007	.23116	.76884		15
40	0	.64279	.35721	1.5557	.83910	1.1918	1.3054	.23396	.76604	50	0
	15	.64612	.35388	1.5477	.84656	1.1812	1.3102	.23677	.76323		45
	30	.64945	.35055	1.5398	.85408	1.1708	1.3151	.23959	.76041		30
	45	.65276	.34724	1.5320	.86165	1.1606	1.3200	.24244	.75756		15
41	0	.65606	.34394	1.5242	.86929	1.1504	1.3250	.24529	.75471	49	0
	15	.65935	.34065	1.5166	.87698	1.1403	1.3301	.24816	.75184		45
	30	.66262	.33738	1.5092	.88472	1.1303	1.3352	.25104	.74896		30
	45	.66588	.33412	1.5018	.89253	1.1204	1.3404	.25394	.74606		15
42	0	.66913	.33087	1.4945	.90040	1.1106	1.3456	.25686	.74314	48	0
	15	.67237	.32763	1.4873	.90834	1.1009	1.3509	.25978	.74022		45
	30	.67559	.32441	1.4802	.91633	1.0913	1.3563	.26272	.73728		30
	45	.67880	.32120	1.4732	.92439	1.0818	1.3618	.26568	.73432		15
43	0	.68200	.31800	1.4663	.93251	1.0724	1.3673	.26865	.73135	47	0
	15	.68518	.31482	1.4595	.94071	1.0630	1.3729	.27163	.72837		45
	30	.68835	.31165	1.4527	.94896	1.0538	1.3786	.27463	.72537		30
	45	.69151	.30849	1.4461	.95729	1.0446	1.3843	.27764	.72236		15
44	0	.69466	.30534	1.4396	.96569	1.0355	1.3902	.28066	.71934	46	0
	15	.69779	.30221	1.4331	.97416	1.0265	1.3961	.28370	.71630		45
	30	.70091	.29909	1.4267	.98270	1.0176	1.4020	.28675	.71325		30
	45	.70401	.29599	1.4204	.99131	1.0088	1.4081	.28981	.71019		15
45	0	.70711	.29289	1.4142	1.0000	1.0000	1.4142	.29289	.70711	45	0

From 45° to 60° read from bottom of table upwards.

## MATERIALS.

## THE CHEMICAL ELEMENTS.

## Common Elements (42).

Chemical Symbol.	Name.	Atomic Weight.	Chemical Symbol.	Name.	Atomic Weight.	Chemical Symbol.	Name.	Atomic Weight.
Al	Aluminum	27.1	F	Fluorine	19.	Pd	Palladium	106.7
Sb	Antimony	120.2	Au	Gold	197.2	P	Phosphorus	31.
As	Arsenic	75.0	H	Hydrogen	1.01	Pt	Platinum	195.2
Ba	Barium	137.4	I	Iodine	126.9	K	Potassium	39.1
Bi	Bismuth	208.0	Ir	Iridium	193.1	Si	Silicon	28.3
B	Boron	11.0	Fe	Iron	55.84	Ag	Silver	107.9
Br	Bromine	79.9	Pb	Lead	207.1	Na	Sodium	23.
Cd	Cadmium	112.4	Li	Lithium	6.94	Sr	Strontium	87.6
Ca	Calcium	40.1	Mg	Magnesium	24.34	S	Sulphur	32.1
C	Carbon	12.	Mn	Manganese	54.9	Sn	Tin	119.
Cl	Chlorine	35.5	Hg	Mercury	200.6	Ti	Titanium	48.1
Cr	Chromium	52.0	Ni	Nickel	58.7	W	Tungsten	184.0
Co	Cobalt	59.	N	Nitrogen	14.01	Va	Vanadium	51.0
Cu	Copper	63.6	O	Oxygen	16.	Zn	Zinc	65.4

The atomic weights of many of the elements vary in the decimal place as given by different authorities. The above are the most recent values referred to O = 16 and H = 1.008. When H is taken as 1, O = 15.879, and the other figures are diminished proportionately.

## Rare Elements (27).

Beryllium, Be.	Indium, In.	Ruthenium, Ru.	Thallium, Tl.
Cæsium, Cs.	Lanthanum, La.	Samarium, Sm.	Thorium, Th.
Cerium, Ce.	Molybdenum, Mo.	Scandium, Sc.	Uranium, U.
Erbium, Er.	Niobium, Nb.	Selenium, Se.	Ytterbium, Yr.
Gallium, Ga.	Osmium, Os.	Tantalum, Ta.	Yttrium, Y.
Germanium, Ge.	Rhodium, R.	Tellurium, Te.	Zirconium, Zr.
Glucinum, G.	Rubidium, Rb.	Terbium, Tb.	

**Elements recently discovered (1895-1900):** Argon, A, 39.9; Krypton Kr, 81.8; Neon, Ne, 20.0; Xenon, X, 128.0; constituents of the atmosphere, which contains about 1 per cent by volume of Argon, and very small quantities of the others. Helium, He, 4.0; Radium, Ra, 225.0; Gadolinium, Gd, 156.0; Neodymium, Nd, 143.6; Præsdodymium, Pr, 140.5; Thulium, Tm, 171.0.

## SPECIFIC GRAVITY.

The specific gravity of a substance is its weight as compared with the weight of an equal bulk of pure water. In the metric system it is the weight in grammes per cubic centimeter.

**To find the specific gravity of a substance.**

$W$  = weight of body in air;  $w$  = weight of body submerged in water.

$$\text{Specific gravity} = \frac{W}{W - w}$$

If the substance be lighter than the water, sink it by means of a heavier substance, and deduct the weight of the heavier substance.

Specific gravity determinations are usually referred to the standard of the weight of water at 62° F., 62.355 lb. per cubic foot. Some experi-

menters have used 60° F. as the standard, and others 32° and 39.1° F. There is no general agreement.

Given sp. gr. referred to water at 39.1° F., to reduce it to the standard of 62° F. multiply it by 1.00112.

Given sp. gr. referred to water at 62° F., to find weight per cubic foot multiply by 62.355. Given weight per cubic foot, to find sp. gr. multiply by 0.016037. Given sp. gr., to find weight per cubic inch multiply by 0.036085.

### Weight and Specific Gravity of Metals.

	Specific Gravity. Range accord- ing to several Authorities.	Specific Grav- ity. Approx. Mean Value, used in Calculation of Weight.	Weight per Cubic Foot, lbs.	Weight per Cubic Inch, lbs.
Aluminum .....	2.56 to 2.71	2.67	166.5	0.0963
Antimony.....	6.66 to 6.86	6.76	421.6	0.2439
Bismuth .....	9.74 to 9.90	9.82	612.4	0.3544
Brass: Copper + Zinc.				
80      20	7.8 to 8.6	8.60	536.3	0.3103
70      30		8.40	523.8	0.3031
60      40		8.36	521.3	0.3017
50      50		8.20	511.4	0.2959
Bronze {Cop., 95 to 80}	8.52 to 8.96	8.853	552.	0.3195
{Tin, 5 to 20}				
Cadmium .....	8.6 to 8.7	8.65	539.	0.3121
Calcium .....	1.58	1.58	98.5	0.0570
Chromium .....	5.0	5.0	311.8	0.1804
Cobalt .....	8.5 to 8.6	8.55	533.1	0.3085
Gold, pure .....	19.245 to 19.361	19.258	1200.9	0.6949
Copper .....	8.69 to 8.92	8.853	552.	0.3195
Iridium .....	22.38 to 23.	22.38	1396.	0.8076
Iron, Cast.....	6.85 to 7.48	7.218	450.	0.2604
Iron, Wrought.....	7.4 to 7.9	7.70	480.	0.2779
Lead .....	11.07 to 11.44	11.38	709.7	0.4106
Manganese .....	7. to 8.	8.	499.	0.2887
Magnesium.....	1.69 to 1.75	1.75	109.	0.0641
Mercury.....	32° 13.61	13.61	848.6	0.4908
	60° 13.58	13.58	846.8	0.4911
	212° 13.37 to 13.38	13.38	834.4	0.4828
Nickel .....	8.279 to 8.93	8.8	548.7	0.3175
Platinum .....	20.33 to 22.07	21.5	1347.0	0.7758
Potassium .....	0.865	0.865	53.9	0.0312
Silver .....	10.474 to 10.511	10.505	655.1	0.3791
Sodium .....	0.97	0.97	60.5	0.0350
Steel.....	7.69* to 7.932†	7.854	489.6	0.2834
Tin .....	7.291 to 7.409	7.350	458.3	0.2652
Titanium .....	5.3	5.3	330.5	0.1913
Tungsten .....	17. to 17.6	17.3	1078.7	0.6243
Zinc.....	6.86 to 7.20	7.00	436.5	0.2526

\* Hard and burned.

† Very pure and soft. The sp. gr. decreases as the carbon is increased. In the first column of figures the lowest are usually those of cast metals, which are more or less porous; the highest are of metals finely rolled or drawn into wire.

The weight of 1 cu. cm. of mercury at 0° C. is 13.59545 grams (Thiessen). Taking atmosphere = 29.92 in. of mercury at 32° F. = 14.6963 lb. per sq. in., 1 cu. in. of mercury = 0.49117 lb. Taking water at 0.036085 lb. per cu. in. at 62° F., the specific gravity of mercury is at 32° F. 13.611.



Specific Gravity of Liquids at 60° F.

Acid, Muriatic.....	1.200	Oil, Olive.....	0.92
“ Nitric.....	1.217	“ Palm.....	0.97
“ Sulphuric.....	1.849	“ Petroleum.....	0.78 to 0.88
Alcohol, pure.....	0.794	“ Rape.....	0.92
“ 95 per cent.....	0.816	“ Turpentine.....	0.86
“ 50 per cent.....	0.934	“ Whale.....	0.92
Ammonia, 27.9 per cent...	0.891	Tar.....	1.
Bromine.....	2.97	Vinegar.....	1.08
Carbon disulphide.....	1.26	Water.....	1.
Ether, Sulphuric.....	0.72	Water, Sea.....	1.026 to 1.03
Oil, Linseed.....	0.93		

Compression of the following Fluids under a Pressure of 15 lbs. per Square Inch.

Water.....	0.00004663	Ether.....	0.00006158
Alcohol.....	0.0000216	Mercury.....	0.00000265

The Hydrometer.

The hydrometer is an instrument for determining the density of liquids. It is usually made of glass, and consists of three parts: (1) the upper part, a graduated stem or fine tube of uniform diameter; (2) a bulb, or enlargement of the tube, containing air; and (3) a small bulb at the bottom, containing shot or mercury which causes the instrument to float in a vertical position. The graduations are figures representing either specific gravities, or the numbers of an arbitrary scale, as in Baumé's Twaddell's, Beck's, and other hydrometers.

There is a tendency to discard all hydrometers with arbitrary scales and to use only those which read in terms of the specific gravity directly.

Baumé's Hydrometer and Specific Gravities Compared.

Formulæ { Heavy liquids, Sp. gr. = 145 ÷ (145 - deg. Be.)  
 { Light liquids, Sp. gr. = 140 ÷ (130 + deg. Be.)

Degrees Baumé	Liquids Heavier than Water, Sp. Gr.	Liquids Lighter than Water, Sp. Gr.	Degrees Baumé	Liquids Heavier than Water, Sp. Gr.	Liquids Lighter than Water, Sp. Gr.	Degrees Baumé	Liquids Heavier than Water, Sp. Gr.	Liquids Lighter than Water, Sp. Gr.
0.0	1.000	.....	19.0	1.151	0.940	38.0	1.355	0.833
1.0	1.007	.....	20.0	1.160	0.933	39.0	1.368	0.828
2.0	1.014	.....	21.0	1.169	0.927	40.0	1.381	0.824
3.0	1.021	.....	22.0	1.179	0.921	41.0	1.394	0.819
4.0	1.028	.....	23.0	1.189	0.915	42.0	1.408	0.814
5.0	1.036	.....	24.0	1.198	0.909	44.0	1.436	0.805
6.0	1.043	.....	25.0	1.208	0.903	46.0	1.465	0.796
7.0	1.051	.....	26.0	1.219	0.897	48.0	1.495	0.787
8.0	1.058	.....	27.0	1.229	0.892	50.0	1.526	0.778
9.0	1.066	.....	28.0	1.239	0.886	52.0	1.559	0.769
10.0	1.074	1.000	29.0	1.250	0.881	54.0	1.593	0.761
11.0	1.082	0.993	30.0	1.261	0.875	56.0	1.629	0.753
12.0	1.090	0.986	31.0	1.272	0.870	58.0	1.667	0.745
13.0	1.099	0.979	32.0	1.283	0.864	60.0	1.706	0.737
14.0	1.107	0.972	33.0	1.295	0.859	65.0	1.813	0.718
15.0	1.115	0.966	34.0	1.306	0.854	70.0	1.933	0.700
16.0	1.124	0.959	35.0	1.318	0.849	75.0	2.071	0.683
17.0	1.133	0.952	36.0	1.330	0.843	.....	.....	.....
18.0	1.142	0.946	37.0	1.343	0.838	.....	.....	.....

### Specific Gravity and Weight of Gases at Atmospheric Pressure and 32° F.

(For other temperatures and pressures see Physical Properties of Gases.)

	Density, Air = 1.	Density, H = 1.	Grammes per Litre.	Lbs. per Cu. Ft.	Cubic Ft. per Lb.
Air.....	1.0000	14.444	1.2931	0.080728	12.388
Oxygen, O.....	1.1052	15.963	1.4291	0.08921	11.209
Hydrogen, H.....	0.0692	1.000	0.0895	0.00559	178.931
Nitrogen, N.....	0.9701	14.012	1.2544	0.07831	12.770
Carbon monoxide, CO..	0.9671	13.968	1.2505	0.07807	12.810
Carbon dioxide, CO <sub>2</sub> ..	1.5197	21.950	1.9650	0.12267	8.152
Methane,marsh-gas,CH <sub>4</sub>	0.5530	7.987	0.7150	0.04464	22.429
Ethylene, C <sub>2</sub> H <sub>4</sub> .....	0.9674	13.973	1.2510	0.07809	12.805
Acetylene, C <sub>2</sub> H <sub>2</sub> .....	0.8982	12.973	1.1614	0.07251	13.792
Ammonia, NH <sub>3</sub> .....	0.5889	8.506	0.7615	0.04754	21.036
Water vapor, H <sub>2</sub> O.....	0.6218	8.981	0.8041	0.05020	19.922
Sulphur dioxide, SO <sub>2</sub> ..	2.213	31.965	2.862	0.1787	5.597

### Specific Gravity and Weight of Wood.

	Specific Gravity.			Weight per Cubic Foot, Pounds.		Specific Gravity.			Weight per Cubic Foot, Pounds.
	Avge.					Avge.			
Alder.....	0.56	to 0.80	0.68	42	Hornbeam..	0.76		0.76	47
Apple.....	0.73	to 0.79	0.76	47	Juniper....	0.56		0.56	35
Ash.....	0.60	to 0.84	0.72	45	Larch.....	0.56		0.56	35
Bamboo.....	0.31	to 0.40	0.35	22	Lignum vitæ	0.65	to 1.33	1.00	62
Beech.....	0.62	to 0.85	0.73	46	Linden...	0.604			37
Birch.....	0.56	to 0.74	0.65	41	Locust.....	0.728			46
Box.....	0.91	to 1.33	1.12	70	Mahogany..	0.56	to 1.06	0.81	51
Cedar.....	0.49	to 0.75	0.62	39	Maple.....	0.57	to 0.79	0.68	42
Cherry.....	0.61	to 0.72	0.66	41	Mulberry...	0.56	to 0.90	0.73	46
Chestnut....	0.46	to 0.66	0.56	35	Oak, Live..	0.96	to 1.26	1.11	59
Cork.....	0.24		0.24	15	Oak, White.	0.69	to 0.86	0.77	48
Cypress....	0.41	to 0.66	0.53	33	Oak, Red..	0.73	to 0.75	0.74	46
Dogwood...	0.76		0.76	47	Pine, White	0.35	to 0.55	0.45	28
Ebony.....	1.13	to 1.33	1.23	76	" Yellow	0.46	to 0.76	0.61	38
Elm.....	0.55	to 0.78	0.61	38	Poplar.....	0.38	to 0.58	0.48	30
Fir.....	0.48	to 0.70	0.59	37	Spruce.....	0.40	to 0.50	0.45	28
Gum.....	0.84	to 1.00	0.92	57	Sycamore...	0.59	to 0.62	0.60	37
Hackmatack	0.59		0.59	37	Teak.....	0.66	to 0.98	0.82	51
Hemlock....	0.36	to 0.41	0.38	24	Walnut....	0.50	to 0.67	0.58	36
Hickory....	0.69	to 0.94	0.77	48	Willow....	0.49	to 0.59	0.54	34
Holly.....	0.76		0.76	47					

**Weight and Specific Gravity of Stones, Brick, Cement, etc. (Pure Water = 1.00.)**

	Lb. per Cu. Ft.	Sp. Gr.
Ashes.....	43	.....
Asphaltum.....	87	1.39
Brick, Soft.....	100	1.6
“ Common.....	112	1.79
“ Hard.....	125	2.0
“ Pressed.....	135	2.16
“ Fire.....	140 to 150	2.24 to 2.4
“ Sand-lime.....	136	2.18
Brickwork in mortar.....	100	1.6
“ “ cement.....	112	1.79
Cement, American, natural.....	...	2.8 to 3.2
“ Portland.....	...	3.05 to 3.15
“ “ loose.....	92	.....
“ “ in barrel.....	115	.....
Clay.....	120 to 150	1.92 to 2.4
Concrete.....	120 to 155	1.92 to 2.48
Earth, loose.....	72 to 80	1.15 to 1.28
“ rammed.....	90 to 110	1.44 to 1.76
Emery.....	250	4.
Glass.....	156 to 172	2.5 to 2.75
“ flint.....	180 to 196	2.88 to 3.14
Gneiss {	160 to 170	2.56 to 2.72
Granite }		
Gravel.....	100 to 120	1.6 to 1.92
Gypsum.....	130 to 150	2.08 to 2.4
Hornblende.....	200 to 220	3.2 to 3.52
Ice.....	55 to 57	0.88 to 0.92
Lime, quick, in bulk.....	50 to 60	0.8 to 0.96
Limestone.....	140 to 185	2.30 to 2.90
Magnesia, Carbonate.....	150	2.4
Marble.....	160 to 180	2.56 to 2.88
Masonry, dry rubble.....	140 to 160	2.24 to 2.56
“ dressed.....	140 to 180	2.24 to 2.88
Mica.....	175	2.80
Mortar.....	90 to 100	1.44 to 1.6
Mud, soft flowing.....	104 to 120	1.67 to 1.92
Pitch.....	72	1.15
Plaster of Paris.....	93 to 113	1.50 to 1.81
Quartz.....	165	2.64
Sand.....	90 to 110	1.44 to 1.76
“ wet.....	118 to 129	1.89 to 2.07
Sandstone.....	140 to 150	2.24 to 2.4
Slate.....	170 to 180	2.72 to 2.88
Soapstone.....	166 to 175	2.65 to 2.8
Stone, various.....	135 to 200	2.16 to 3.4
“ crushed.....	100	.....
Tile.....	110 to 120	1.76 to 1.92
Trap Rock.....	170 to 200	2.72 to 3.4

**PROPERTIES OF THE USEFUL METALS.**

**Aluminum, Al.** — Atomic weight 27.1. Specific gravity 2.6 to 2.7. The lightest of all the useful metals except magnesium. A soft, ductile, malleable metal, of a white color, approaching silver, but with a bluish cast. Very non-corrosive. Tenacity about one-third that of wrought iron. Formerly a rare metal, but since 1890 its production and use have greatly increased on account of the discovery of cheap processes for reducing it from the ore. Melts at 1215° F. For further description see Aluminum, under Strength of Materials, page 380.

**Antimony (Stibium), Sb.** — At. wt. 120.2 Sp. gr. 6.7 to 6.8. A brittle metal of a bluish-white color and highly crystalline or laminated structure. Melts at 842° F. Heated in the open air it burns with a

bluish-white flame. Its chief use is for the manufacture of certain alloys, as type-metal (antimony 1, lead 4), britannia (antimony 1, tin 9), and various anti-friction metals (see Alloys). Cubical expansion by heat from 32° to 212° F., 0.0070. Specific heat 0.050.

**Bismuth, Bi.** — At. wt. 208.5. Bismuth is of a peculiar light reddish color, highly crystalline, and so brittle that it can readily be pulverized. It melts at 510° F., and boils at about 2300° F. Sp. gr. 9.823 at 54° F., and 10.055 just above the melting-point. Specific heat about 0.0301 at ordinary temperatures. Coefficient of cubical expansion from 32° to 212°, 0.0040. Conductivity for heat about  $\frac{1}{56}$  and for electricity only about  $\frac{1}{80}$  of that of silver. Its tensile strength is about 6400 lbs. per square inch. Bismuth expands in cooling, and Tribe has shown that this expansion does not take place until after solidification. Bismuth is the most diamagnetic element known, a sphere of it being repelled by a magnet.

**Cadmium, Cd.** — At. wt. 112.4. Sp. gr. 8.6 to 8.7. A bluish-white metal, lustrous, with a fibrous fracture. Melts below 500° F. and volatilizes at about 680° F. It is used as an ingredient in some fusible alloys with lead, tin, and bismuth. Cubical expansion from 32° to 212° F., 0.0094.

**Copper, Cu.** — At. wt. 63.6. Sp. gr. 8.81 to 8.95. Fuses at about 1930° F. Distinguished from all other metals by its reddish color. Very ductile and malleable, and its tenacity is next to iron. Tensile strength 20,000 to 30,000 lbs. per square inch. Heat conductivity 73.6% of that of silver, and superior to that of other metals. Electric conductivity equal to that of gold and silver. Expansion by heat from 32° to 212° F., 0.0051 of its volume. Specific heat 0.093. (See Copper under Strength of Materials; also Alloys.)

**Gold (Aurum), Au.** — At. wt. 197.2. Sp. gr., when pure and pressed in a die, 19.34. Melts at about 1915° F. The most malleable and ductile of all metals. One ounce Troy may be beaten so as to cover 160 sq. ft. of surface. The average thickness of gold-leaf is  $\frac{1}{282000}$  of an inch, or 100 sq. ft. per ounce. One grain may be drawn into a wire 500 ft. in length. The ductility is destroyed by the presence of  $\frac{1}{2000}$  part of lead, bismuth, or antimony. Gold is hardened by the addition of silver or of copper. U. S. gold coin is 90 parts gold and 10 parts alloy, which is chiefly copper with a little silver. By jewelers the fineness of gold is expressed in carats, pure gold being 24 carats, three-fourths fine 18 carats, etc.

**Iridium, Ir.** — Iridium is one of the rarer metals. It has a white lustre, resembling that of steel; its hardness is about equal to that of the ruby; in the cold it is quite brittle, but at white heat it is somewhat malleable. It is one of the heaviest of metals, having a specific gravity of 22.38. It is extremely infusible and almost absolutely inoxidizable.

For uses of iridium, methods of manufacturing it, etc., see paper by W. L. Dudley on the "Iridium Industry," Trans. A. I. M. E., 1884.

**Iron (Ferrum), Fe.** — At. wt. 55.9. Sp. gr.: Cast, 6.85 to 7.48; Wrought, 7.4 to 7.9. Pure iron is extremely infusible, its melting point being above 3000° F., but its fusibility increases with the addition of carbon, cast iron fusing about 2500° F. Conductivity for heat 11.9, and for electricity 12 to 14.8, silver being 100. Expansion in bulk by heat: cast iron 0.0033, and wrought iron 0.0035, from 32° to 212° F. Specific heat: cast iron 0.1298, wrought iron 0.1138, steel 0.1165. Cast iron exposed to continued heat becomes permanently expanded 1  $\frac{1}{2}$  to 3 per cent of its length. Grate-bars should therefore be allowed about 4 per cent play. (For other properties see Iron and Steel under Strength of Materials.)

**Lead (Plumbum), Pb.** — At. wt. 206.9. Sp. gr. 11.07 to 11.44 by different authorities. Melts at about 625° F., softens and becomes pasty at about 617° F. If broken by a sudden blow when just below the melting-point it is quite brittle and the fracture appears crystalline. Lead is very malleable and ductile, but its tenacity is such that it can be drawn into wire with great difficulty. Tensile strength, 1600 to 2400 lbs. per square inch. Its elasticity is very low, and the metal flows under very slight strain. Lead dissolves to some extent in pure water, but water containing carbonates or sulphates forms over it a film of insoluble salt which prevents further action.



**Magnesium, Mg.** — At. wt. 24.36. Sp. gr. 1.69 to 1.75. Silver-white, brilliant, malleable, and ductile. It is one of the lightest of metals, weighing only about two thirds as much as aluminum. In the form of filings, wire, or thin ribbons it is highly combustible, burning with a light of dazzling brilliancy, useful for signal-lights and for flash-lights for photographers. It is nearly non-corrosive, a thin film of carbonate of magnesia forming on exposure to damp air, which protects it from further corrosion. It may be alloyed with aluminum, 5 per cent Mg added to Al giving about as much increase of strength and hardness as 10 per cent of copper. Cubical expansion by heat 0.0083, from 32° to 212° F. Melts at 1200° F. Specific heat 0.25.

**Manganese, Mn.** — At. wt. 55. Sp. gr. 7 to 8. The pure metal is not used in the arts, but alloys of manganese and iron, called spiegeleisen when containing below 25 per cent of manganese, and ferro-manganese when containing from 25 to 90 per cent, are used in the manufacture of steel. Metallic manganese, when alloyed with iron, oxidizes rapidly in the air, and its function in steel manufacture is to remove the oxygen from the bath of steel whether it exists as oxide of iron or as occluded gas.

**Mercury (Hydrargyrum), Hg.** — At. wt. 199.8. A silver-white metal, liquid at temperatures above - 39° F., and boils at 680° F. Unchangeable as gold, silver, and platinum in the atmosphere at ordinary temperatures, but oxidizes to the red oxide when near its boiling-point. Sp. gr.: when liquid 13.58 to 13.59, when frozen 14.4 to 14.5. Easily tarnished by sulphur fumes, also by dust, from which it may be freed by straining through a cloth. No metal except iron or platinum should be allowed to touch mercury. The smallest portions of tin, lead, zinc, and even copper to a less extent, cause it to tarnish and lose its perfect liquidity. Coefficient of cubical expansion from 32° to 212° F. 0.0182; per deg. 0.000101.

**Nickel, Ni.** — At. wt. 58.7. Sp. gr. 8.27 to 8.93. A silvery-white metal with a strong lustre, not tarnishing on exposure to the air. Ductile, hard, and as tenacious as iron. It is attracted to the magnet and may be made magnetic like iron. Nickel is very difficult of fusion, melting at about 3000° F. Chiefly used in alloys with copper, as german-silver, nickel-silver, etc., and also in the manufacture of steel to increase its hardness and strength, also for nickel-plating. Cubical expansion from 32° to 212° F., 0.0038. Specific heat 0.109.

**Platinum, Pt.** — At. wt. 194.8. A whitish steel-gray metal, malleable, very ductile, and as unalterable by ordinary agencies as gold. When fused and refined it is as soft as copper. Sp. gr. 21.15. It is fusible only by the oxyhydrogen blowpipe or in strong electric currents. When combined with iridium it forms an alloy of great hardness, which has been used for gun-vents and for standard weights and measures. The most important uses of platinum in the arts are for vessels for chemical laboratories and manufactories, and for the connecting wires in incandescent electric lamps and for electrical contact points. Cubical expansion from 32° to 212° F., 0.0027, less than that of any other metal except the rare metals, and almost the same as glass.

**Silver (Argentum), Ag.** — At. wt. 107.9. Sp. gr. 10.1 to 11.1, according to condition and purity. It is the whitest of the metals, very malleable and ductile, and in hardness intermediate between gold and copper. Melts at about 1750° F. Specific heat 0.056. Cubical expansion from 32° to 212° F., 0.0058. As a conductor of electricity it is equal to copper. As a conductor of heat it is superior to all other metals.

**Tin (Stannum), Sn.** — At. wt. 119. Sp. gr. 7.293. White, lustrous, soft, malleable, of little strength, tenacity about 3500 lbs. per square inch. Fuses at 442° F. Not sensibly volatile when melted at ordinary heats. Heat conductivity 14.5, electric conductivity 12.4; silver being 100 in each case. Expansion of volume by heat 0.0069 from 32° to 212° F. Specific heat 0.055. Its chief uses are for coating of sheet-iron (called tin plate) and for making alloys with copper and other metals.

**Zinc, Zn.** — At. wt. 65.4. Sp. gr. 7.14. Melts at 780° F. Volatilizes and burns in the air when melted, with bluish-white fumes of zinc oxide. It is ductile and malleable, but to a much less extent than copper, and

its tenacity, about 5000 to 6000 lbs. per square inch, is about one tenth that of wrought iron. It is practically non-corrosive in the atmosphere, a thin film of carbonate of zinc forming upon it. Cubical expansion between 32° and 212° F., 0.0088. Specific heat 0.096. Electric conductivity 29, heat conductivity 36, silver being 100. Its principal uses are for coating iron surfaces, called "galvanizing," and for making brass and other alloys.

Table Showing the Order of

Malleability.	Ductility.	Tenacity.	Infusibility.
Gold	Platinum	Iron	Platinum
Silver	Silver	Copper	Iron
Aluminum	Iron	Aluminum	Copper
Copper	Copper	Platinum	Gold
Tin	Gold	Silver	Silver
Lead	Aluminum	Zinc	Aluminum
Zinc	Zinc	Gold	Zinc
Platinum	Tin	Tin	Lead
Iron	Lead	Lead	Tin

**MEASURES AND WEIGHTS OF VARIOUS MATERIALS (APPROXIMATE).**

**Brickwork.** — Brickwork is estimated by the thousand, and for various thicknesses of wall runs as follows:

8 1/4-in. wall, or 1 brick in thickness, 14 bricks per superficial foot.			
12 3/4 " " " 1 1/2 " " "	21	"	"
17 " " " 2 " " "	28	"	"
21 1/2 " " " 2 1/2 " " "	35	"	"

An ordinary brick measures about 8 1/4 X 4 X 2 inches, which is equal to 66 cubic inches, or 26.2 bricks to a cubic foot. The average weight is 4 1/2 lbs.

**Fuel.** — A bushel of bituminous coal weighs 76 pounds and contains 2688 cubic inches = 1.554 cubic feet. 29.47 bushels = 1 gross ton.

One acre of bituminous coal contains 1600 tons of 2240 pounds per foot of thickness of coal worked. 15 to 25 per cent must be deducted for waste in mining.

41 to 45 cubic feet bituminous coal when broken down	= 1 ton, 2240 lbs.
34 to 41 " " anthracite prepared for market	= 1 ton, 2240 lbs.
123 " " of charcoal	= 1 ton, 2240 lbs.
70.9 " " coke	= 1 ton, 2240 lbs.
1 cubic foot of anthracite coal	= 55 to 66 lbs.
1 " " bituminous coal	= 50 to 55 lbs.
1 " " Cumberland (semi-bituminous) coal	= 53 lbs.
1 " " Cannel coal	= 50.3 lbs.
1 " " Charcoal (hardwood)	= 18.5 lbs.
1 " " (pine)	= 18 lbs.

A bushel of coke weighs 40 pounds (35 to 42 pounds).

**A bushel of charcoal.** — In 1881 the American Charcoal-Iron Workers' Association adopted for use in its official publications for the standard bushel of charcoal 2748 cubic inches, or 20 pounds. A ton of charcoal is to be taken at 2000 pounds. This figure of 20 pounds to the bushel was taken as a fair average of different bushels used throughout the country, and it has since been established by law in some States.

**Cement.** — Portland, per bbl. net, 376 lbs., per bag, net. . . . . 94 lbs.  
 Natural, per bbl. net, 282 lbs., per bag net. . . . . 94 lbs.

**Lime.** — A struck bushel . . . . . 72 to 75 lbs.

**Grain.** — A struck bushel of wheat = 60 lbs.; of corn = 56 lbs.; of oats = 30 lbs.

**Salt.** — A struck bushel of salt, coarse, Syracuse, N. Y. = 56 lbs.; Turk's Island = 76 to 80 lbs.

**Ores, Earths, etc.**

13 cubic feet of ordinary gold or silver ore, in mine	= 1 ton = 2000 lbs.
20 " " " broken quartz	..... = 1 ton = 2000 lbs.
18 feet of gravel in bank	..... = 1 ton.
27 cubic feet of gravel when dry	..... = 1 ton.
25 " " " sand	..... = 1 ton.
18 " " " earth in bank	..... = 1 ton.
27 " " " earth when dry	..... = 1 ton.
17 " " " clay	..... = 1 ton.

Except where otherwise stated, a ton = 2240 lbs.

**WEIGHTS OF LOGS, LUMBER, ETC.**

**Weight of Green Logs to Scale 1000 Feet, Board Measure.**

Yellow pine (Southern)	8,000 to 10,000 lbs.
Norway pine (Michigan)	7,000 to 8,000 "
White pine (Michigan)	{ off of stump..... 7,000 to 7,000 "
	{ out of water..... 7,000 to 8,000 "
White pine (Pennsylvania), bark off	5,000 to 6,000 "
Hemlock (Pennsylvania), bark off	6,000 to 7,000 "

Four acres of water are required to store 1,000,000 feet of logs.

**Weight of 1000 Feet of Lumber, Board Measure.**

Yellow or Norway pine	Dry, 3,000 lbs.	Green, 5,000 lbs.
White pine	" 2,500 "	" 4,000 "

**Weight of 1 Cord of Seasoned Wood, 128 Cu. Ft. per Cord, lbs.**

Hickory or sugar maple	4,500	{ Poplar, chestnut or elm... 2,350 Pine (white or Norway)... 2,000 Hemlock bark, dry..... 2,200
White oak	3,850	
Beech, red oak or black oak	3,250	

**WEIGHT OF RODS, BARS, PLATES, TUBES, AND SPHERES OF DIFFERENT MATERIALS.**

Notation: *b* = breadth, *t* = thickness, *s* = side of square, *D* = external diameter, *d* = internal diameter, all in inches.

Sectional areas: of square bars = *s*<sup>2</sup>; of flat bars = *bt*; of round rods = 0.7854 *D*<sup>2</sup>; of tubes = 0.7854 (*D*<sup>2</sup> - *d*<sup>2</sup>) = 3.1416 (*Dt* - *t*<sup>2</sup>).

Volume of 1 foot in length: of square bars = 12*s*<sup>2</sup>; of flat bars = 12*bt*; of round bars = 9.4248*D*<sup>2</sup>; of tubes = 9.4248 (*D*<sup>2</sup> - *d*<sup>2</sup>) = 37.699 (*Dt* - *t*<sup>2</sup>), in cu. in.

Weight per foot length = volume + weight per cubic inch of material. Weight of a sphere = diam.<sup>3</sup> × 0.5236 × weight per cubic inch.

Material.	Specific Gravity.	Wt. per Cu. Ft., Lb.	Wt. of Plates 1" Thick per Sq. Ft., Lb.	Wt. per Ft. of Square Bars, Lb.	Wt. per Ft. of Flat Bars, Lb.	Wt. per Cu. In., Lb.	Relative Wt. of Wrought Iron = <i>t</i> .	Wt. per Ft. of Round Rod, Lb.	Wt. of Spheres, Lb.
				$s^2 \times$	$bt \times$			$D^2 \times$	$D^3 \times$
Cast iron.....	7.218	450.	37.5	$3\frac{1}{8}$	$3\frac{1}{8}$	.2604	15-16	2.454	.1363
Wrought iron.....	7.7	480.	40.	$3\frac{1}{3}$	$3\frac{1}{3}$	.2779	1.	2.618	.1455
Steel.....	7.854	489.6	40.8	3.4	3.4	.2833	1.02	2.670	.1484
Copper & Bronze (copper and tin)	8.855	552.	46.	3.833	3.833	.3195	1.15	3.011	.1673
Brass { 65 copper 35 Zinc... }	8.393	523.2	43.6	3.633	3.633	.3029	1.09	2.854	.1586
Lead.....	11.33	709.6	59.1	4.93	4.93	.4106	1.48	3.870	.2150
Aluminum.....	2.67	166.5	13.9	1.16	1.16	.0963	0.347	0.908	.0504
Glass.....	2.62	163.4	13.6	1.13	1.13	.0945	0.34	0.891	.0495
Pine wood, dry....	0.481	30.0	2.5	0.21	0.21	.0174	1-16	0.164	.0091

Weight per cylindrical in., 1 in. long, = coefficient of *D*<sup>2</sup> in next to last col. + 12.



**For tubes** use the coefficient of  $D^2$  in next to last column, as for rods, and multiply it into  $(D^2 - d^2)$ ; or multiply it by 4  $(Dt - t^2)$ .

**For hollow spheres** use the coefficient of  $D^3$  in the last column and multiply it into  $(D^3 - d^3)$ .

**For hexagons** multiply the weight of square bars by 0.866 (short diam. of hexagon = side of square). **For octagons** multiply by 0.8284.

## COMMERCIAL SIZES OF MERCHANT IRON AND STEEL BARS.

### Steel Bars.

**Flats, Square Edge.**— $\frac{3}{8}$  to 3 in. wide, by any thickness from  $\frac{1}{8}$  in. up to width; 3 to 5 in. wide by any thickness  $\frac{1}{4}$  to 3 in. inclusive; 5 to 7 in. wide, by any thickness,  $\frac{1}{4}$  to 2 in. inclusive.

**Flats, Band Edge.**—Thicknesses are in B. W. G.,  $\frac{3}{8}$  in. wide by No. 18 to No. 4.  $\frac{7}{16}$  in. by No. 19 to No. 4.  $\frac{1}{2}$  in. by No. 22 to No. 4.  $\frac{9}{16}$  to 1 in. by No. 23 to No. 4.  $\frac{11}{16}$  to 2 in. by No. 22 to No. 4.  $\frac{21}{16}$  to 3 in. by No. 21 to No. 1.  $\frac{39}{16}$  to 4 in. by No. 19 to No. 1.  $\frac{41}{16}$  to  $4\frac{1}{2}$  in. by No. 18 to No. 1.  $\frac{49}{16}$  to  $5\frac{1}{16}$  in. by No. 17 to No. 1.  $5\frac{1}{8}$  to  $6\frac{3}{4}$  in. by No. 16 to No. 1. 7 in.,  $7\frac{1}{4}$  in.,  $7\frac{1}{2}$  in.,  $7\frac{5}{8}$  in.,  $7\frac{3}{4}$  in.,  $7\frac{7}{8}$  in., 8 in.,  $8\frac{1}{4}$  in.,  $8\frac{1}{2}$  in.,  $8\frac{5}{8}$  in., each by No. 14 to No. 1.  $9\frac{5}{8}$  in. by No. 12 to No. 1.

**Squares.**—Widths across faces:  $\frac{3}{16}$  to 2 in., advancing by  $\frac{1}{64}$  in.;  $2\frac{1}{32}$  to  $3\frac{1}{2}$  in., advancing by  $\frac{1}{32}$  in.;  $3\frac{9}{16}$  to  $5\frac{1}{2}$  in., advancing by  $\frac{1}{16}$  in.

**Round-cornered Squares.**— $\frac{1}{4}$  to  $\frac{3}{4}$  in., across faces, advancing by  $\frac{1}{64}$  in.

**Rounds.**—Diameters:  $\frac{7}{32}$  to  $1\frac{3}{4}$  in., inclusive, advancing by  $\frac{1}{64}$  in.;  $1\frac{25}{32}$  in. to  $3\frac{1}{2}$  in. inclusive, advancing by  $\frac{1}{32}$ ;  $3\frac{9}{16}$  to 7 in., inclusive, advancing by  $\frac{1}{16}$  in.

**Half Rounds.**—Diameters:  $\frac{5}{16}$  to  $\frac{7}{8}$  in., inclusive, advancing by  $\frac{1}{64}$  in.;  $\frac{15}{16}$  to  $1\frac{3}{4}$  in., advancing by  $\frac{1}{16}$  in.; 2 in.;  $2\frac{1}{2}$  in.; 3 in.

**Hexagons.**—Width across faces:  $\frac{1}{4}$  to  $1\frac{3}{16}$  in., inclusive, advancing by  $\frac{1}{32}$  in.;  $1\frac{1}{4}$  in. to  $3\frac{1}{16}$  in., advancing by  $\frac{1}{16}$  in.

### Iron Bars.

**Round.**— $\frac{3}{16}$  to  $1\frac{7}{8}$  in., advancing by  $\frac{1}{32}$  in.;  $1\frac{15}{16}$  to  $2\frac{3}{4}$  in., advancing by  $\frac{1}{16}$  in.;  $2\frac{7}{8}$  to  $3\frac{3}{4}$  in., advancing by  $\frac{1}{8}$  in.; 4 to 5 in., advancing by  $\frac{1}{4}$  in.

**Squares.**— $\frac{3}{16}$  to  $\frac{5}{8}$  in., advancing by  $\frac{1}{32}$  in.;  $\frac{11}{16}$  in. to 1 in., advancing by  $\frac{1}{16}$  in.;  $1\frac{1}{8}$  in. to  $2\frac{1}{2}$  in., advancing by  $\frac{1}{8}$  in.;  $2\frac{3}{4}$  in. to  $4\frac{1}{2}$  in., advancing by  $\frac{1}{4}$  in.

**Half Rounds.**— $\frac{3}{8}$ ,  $\frac{7}{16}$ ,  $\frac{1}{2}$ ,  $\frac{5}{8}$ ,  $\frac{11}{16}$ ,  $\frac{3}{4}$ ,  $\frac{7}{8}$ , 1,  $1\frac{1}{8}$ ,  $1\frac{1}{4}$ ,  $1\frac{3}{8}$ ,  $1\frac{1}{2}$ ,  $1\frac{3}{4}$ , 2 in.

**Ovals.**— $\frac{1}{2} \times \frac{1}{4}$ ,  $\frac{5}{8} \times \frac{5}{16}$ ,  $\frac{3}{4} \times \frac{3}{8}$  and  $\frac{7}{8} \times \frac{7}{16}$  in.

**Half Ovals.**— $\frac{1}{2} \times \frac{3}{16}$ ,  $\frac{5}{8} \times \frac{3}{16}$ ,  $\frac{3}{4} \times \frac{3}{16}$ ,  $\frac{7}{8} \times \frac{3}{16}$ ,  $1 \times \frac{3}{16}$ ,  $\frac{3}{4} \times \frac{1}{4}$ ,  $\frac{7}{8} \times \frac{1}{4}$ ,  $1 \times \frac{1}{4}$ ,  $1\frac{1}{8} \times \frac{1}{4}$ ,  $1 \times \frac{5}{16}$ ,  $1\frac{1}{8} \times \frac{5}{16}$ ,  $1\frac{1}{4} \times \frac{5}{16}$ ,  $1 \times \frac{3}{8}$ ,  $1\frac{1}{8} \times \frac{3}{8}$ ,  $1\frac{1}{4} \times \frac{3}{8}$ ,  $1\frac{1}{2} \times \frac{3}{8}$ ,  $1\frac{3}{4} \times \frac{1}{2}$ ,  $2 \times \frac{5}{8}$  in.

**Flats.**— $\frac{1}{2} \times \frac{3}{16}$  to  $\frac{3}{8}$  in.;  $\frac{5}{8} \times \frac{3}{16}$  to  $\frac{1}{2}$  in.;  $\frac{3}{4} \times \frac{3}{16}$  to  $\frac{5}{8}$  in.;  $\frac{7}{8} \times \frac{3}{16}$  to  $\frac{3}{4}$  in.;  $1 \times \frac{3}{16}$  to  $\frac{7}{8}$  in.;  $1\frac{1}{16} \times \frac{1}{4}$  to  $\frac{7}{8}$  in.;  $1\frac{1}{8} \times \frac{3}{16}$  to 1 in.;  $1\frac{1}{4} \times \frac{3}{16}$  to 1 in.;  $1\frac{3}{8} \times \frac{3}{16}$  to  $1\frac{1}{8}$  in.;  $1\frac{1}{2} \times \frac{3}{16}$  to  $1\frac{1}{4}$  in.;  $1\frac{5}{8} \times \frac{1}{4}$  to  $1\frac{1}{2}$  in.;  $1\frac{3}{4} \times \frac{3}{16}$  to  $1\frac{1}{2}$  in.;  $1\frac{7}{8} \times \frac{1}{4}$  to  $1\frac{1}{2}$  in.;  $2 \times \frac{3}{16}$  to  $1\frac{3}{4}$  in.;  $2\frac{1}{8} \times \frac{1}{4}$  to  $1\frac{1}{4}$  in.;  $2\frac{1}{4} \times \frac{3}{16}$  to 2 in.;  $2\frac{3}{8} \times \frac{1}{4}$  to  $1\frac{3}{4}$  in.;  $2\frac{1}{2} \times \frac{3}{16}$  to  $2\frac{1}{4}$  in.;  $2\frac{5}{8} \times \frac{1}{4}$  to  $2\frac{1}{4}$  in.;  $2\frac{3}{4} \times \frac{3}{16}$  to  $2\frac{1}{2}$  in.;  $2\frac{7}{8} \times \frac{3}{8}$  to  $2\frac{1}{2}$  in.;  $2\frac{7}{8} \times \frac{7}{8}$  to  $2\frac{1}{4}$  in.;  $3 \times \frac{3}{16}$  to  $2\frac{3}{4}$  in.;  $3\frac{1}{8} \times 1\frac{1}{2}$  to  $2\frac{5}{8}$  in.;  $3\frac{1}{4} \times \frac{1}{4}$  to  $2\frac{3}{4}$  in.;  $3\frac{1}{2} \times \frac{3}{16}$  to  $2\frac{7}{8}$  in.;  $3\frac{3}{4} \times \frac{1}{4}$  to 3 in.;  $4 \times \frac{1}{4}$  to 3 in.;  $4\frac{1}{4} \times \frac{1}{4}$  to 2 in.;  $4\frac{1}{2} \times \frac{1}{4}$  to  $2\frac{1}{2}$  in.;  $4\frac{3}{4} \times \frac{1}{4}$  to 2 in.;  $5 \times \frac{1}{4}$  to  $2\frac{3}{4}$  in.;  $5\frac{1}{2} \times \frac{1}{4}$  to 2 in.;  $6 \times \frac{1}{4}$  to 2 in.;  $6\frac{1}{2} \times \frac{1}{4}$  to 1 in.;  $7 \times \frac{1}{4}$  to 2 in.;  $7\frac{1}{2} \times \frac{1}{4}$  to 1 in.;  $8 \times \frac{1}{4}$  to 2 in.

**Round Edge Flats.**—1 to 2 in. wide by  $\frac{1}{4}$  to  $1\frac{1}{4}$  in. thick;  $2\frac{1}{4}$  to  $4\frac{1}{2}$  in. wide by  $\frac{3}{8}$  to  $1\frac{1}{4}$  in. thick.



**WEIGHT OF IRON AND STEEL SHEETS.**

**Weights in Pounds per Square Foot.**

(For weights by the Decimal Gauge, see page 33.)

Thickness by Birmingham Gauge.				U. S. Standard Gauge, 1893. (See p. 32.)			
No. of Gauge.	Thick-ness in Inches.	Iron.	Steel.	No. of Gauge.	Thick-ness, In. (Approx.)	Iron.	Steel.
0000	0.454	18.16	18.52	0000000	0.5	20.	20.40
000	.425	17.00	17.34	000000	0.4688	18.75	19.125
00	.38	15.20	15.50	00000	0.4375	17.50	17.85
0	.34	13.60	13.87	0000	0.4063	16.25	16.575
1	.3	12.00	12.24	000	0.375	15.	15.30
2	.284	11.36	11.59	00	0.3438	13.75	14.025
3	.259	10.36	10.57	0	0.3125	12.50	12.75
4	.238	9.52	9.71	1	0.2813	11.25	11.475
5	.22	8.80	8.98	2	0.2656	10.625	10.837
6	.203	8.12	8.28	3	0.25	10.	10.20
7	.18	7.20	7.34	4	0.2344	9.375	9.562
8	.165	6.60	6.73	5	0.2188	8.75	8.925
9	.148	5.92	6.04	6	0.2031	8.125	8.287
10	.134	5.36	5.47	7	0.1875	7.5	7.65
11	.12	4.80	4.90	8	0.1719	6.875	7.012
12	.109	4.36	4.45	9	0.1563	6.25	6.375
13	.095	3.80	3.88	10	0.1405	5.625	5.737
14	.083	3.32	3.39	11	0.125	5.	5.10
15	.072	2.88	2.94	12	0.1094	4.375	4.462
16	.065	2.60	2.65	13	0.0938	3.75	3.825
17	.058	2.32	2.37	14	0.0781	3.125	3.187
18	.049	1.96	2.00	15	0.0703	2.8125	2.869
19	.042	1.68	1.71	16	0.0625	2.5	2.55
20	.035	1.40	1.43	17	0.0563	2.25	2.295
21	.032	1.28	1.31	18	0.05	2.	2.04
22	.028	1.12	1.14	19	0.0438	1.75	1.785
23	.025	1.00	1.02	20	0.0375	1.50	1.53
24	.022	.88	.898	21	0.0344	1.375	1.402
25	.02	.80	.816	22	0.0312	1.25	1.275
26	.018	.72	.734	23	0.0281	1.125	1.147
27	.016	.64	.653	24	0.025	1.	1.02
28	.014	.56	.571	25	0.0219	0.875	0.892
29	.013	.52	.530	26	0.0188	0.75	0.765
30	.012	.48	.490	27	0.0172	0.6875	0.701
31	.01	.40	.408	28	0.0156	0.625	0.637
32	.009	.36	.367	29	0.0141	0.5625	0.574
33	.008	.32	.326	30	0.0125	0.5	0.51
34	.007	.28	.286	31	0.0109	0.4375	0.446
35	.005	.20	.204	32	0.0102	0.40625	0.414
36	.004	.16	.163	33	0.0094	0.375	0.382
				34	0.0086	0.34375	0.351
				35	0.0078	0.3125	0.319
				36	0.0070	0.28125	0.287
				37	0.0066	0.26562	0.271
				38	0.0063	0.25	0.255

	Iron.	Steel.
Specific gravity.....	7.7	7.854
Weight per cubic foot.....	480.	489.6
Weight per cubic inch.....	0.2778	0.2833

As there are many gauges in use differing from each other, and even the thicknesses of a certain specified gauge, as the Birmingham, are not assumed the same by all manufacturers, orders for sheets and wires should always state the weight per square foot, or the thickness in thousandths of an inch.

**WEIGHTS OF SQUARE AND ROUND BARS OF WROUGHT IRON IN POUNDS PER LINEAL FOOT.**

Iron weighing 480 lb. per cubic foot. For steel add 2 per cent.

Thickness or Diameter in Inches.	Weight of Square Bar 1 Ft. Long.	Weight of Round Bar 1 Ft. Long.	Thickness or Diameter in Inches.	Weight of Square Bar 1 Ft. Long.	Weight of Round Bar 1 Ft. Long.	Thickness or Diameter in Inches.	Weight of Square Bar 1 Ft. Long.	Weight of Round Bar 1 Ft. Long.
<b>0</b>								
1/16	0.013	0.010	11/16	24.08	18.91	3/8	96.30	75.64
1/8	.052	.041	3/4	25.21	19.80	7/16	98.55	77.40
3/16	.117	.092	13/16	26.37	20.71	1/2	100.8	79.19
1/4	.208	.164	7/8	27.55	21.64	5/16	103.1	81.00
5/16	.326	.256	15/16	28.76	22.59	5/8	105.5	82.83
3/8	.469	.368	<b>3</b>	30.00	23.56	11/16	107.8	84.69
7/16	.638	.501	1/16	31.26	24.55	3/4	110.2	86.56
1/2	.833	.654	1/8	32.55	25.57	13/16	112.6	88.45
9/16	1.055	.828	3/16	33.87	26.60	7/8	115.1	90.36
5/8	1.302	1.023	1/4	35.21	27.65	15/16	117.5	92.29
11/16	1.576	1.237	5/16	36.58	28.73	<b>6</b>	120.0	94.25
3/4	1.875	1.473	3/8	37.97	29.82	1/8	125.1	98.22
13/16	2.201	1.728	7/16	39.39	30.94	1/4	130.2	102.3
7/8	2.552	2.004	1/2	40.83	32.07	3/8	135.5	106.4
15/16	2.930	2.301	9/16	42.30	33.23	1/2	140.8	110.6
<b>1</b>	3.333	2.618	5/8	43.80	34.40	5/8	146.3	114.9
1/16	3.763	2.955	11/16	45.33	35.60	3/4	151.9	119.3
1/8	4.219	3.313	3/4	46.88	36.82	7/8	157.6	123.7
3/16	4.701	3.692	13/16	48.45	38.05	<b>7</b>	163.3	128.3
1/4	5.208	4.091	7/8	50.05	39.31	1/8	169.2	132.9
5/16	5.742	4.510	15/16	51.68	40.59	1/4	175.2	137.6
3/8	6.302	4.950	<b>4</b>	53.33	41.89	3/8	181.3	142.4
7/16	6.888	5.410	1/16	55.01	43.21	1/2	187.5	147.3
1/2	7.500	5.890	1/8	56.72	44.55	5/8	193.8	152.2
9/16	8.138	6.392	3/16	58.45	45.91	3/4	200.2	157.2
5/8	8.802	6.913	1/4	60.21	47.29	7/8	206.7	162.4
11/16	9.492	7.455	5/16	61.99	48.69	<b>8</b>	213.3	167.6
3/4	10.21	8.018	3/8	63.80	50.11	1/4	226.9	178.2
13/16	10.95	8.601	7/16	65.64	51.55	1/2	240.8	189.2
7/8	11.72	9.204	1/2	67.50	53.01	3/4	255.2	200.4
15/16	12.51	9.828	9/16	69.39	54.50	<b>9</b>	270.0	212.1
<b>2</b>	13.33	10.47	5/8	71.30	56.00	1/4	285.2	224.0
1/16	14.18	11.14	11/16	73.24	57.52	1/2	300.8	236.3
1/8	15.05	11.82	3/4	75.21	59.07	3/4	316.9	248.9
3/16	15.95	12.53	13/16	77.20	60.63	<b>10</b>	333.3	261.8
1/4	16.88	13.25	7/8	79.22	62.22	1/4	350.2	275.1
5/16	17.83	14.00	15/16	81.26	63.82	1/2	367.5	288.6
3/8	18.80	14.77	<b>5</b>	83.33	65.45	3/4	385.2	302.5
7/16	19.80	15.55	1/16	85.43	67.10	<b>11</b>	403.3	316.8
1/2	20.83	16.36	1/8	87.55	68.76	1/4	421.9	331.3
9/16	21.89	17.19	3/16	89.70	70.45	1/2	440.8	346.2
5/8	22.97	18.04	1/4	91.88	72.16	3/4	460.2	361.4
			5/16	94.08	73.89	<b>12</b>	480.	377.

**WEIGHT OF SQUARE AND ROUND STEEL BARS PER LINEAL FOOT.** (Steel Weighing 489.6 lb. per cu. ft.)

Thickness or Diameter in Inches.	Weight of Square Bar 1 Ft. Long.	Weight of Round Bar 1 Ft. Long.	Thickness or Diameter in Inches.	Weight of Square Bar 1 Ft. Long.	Weight of Round Bar 1 Ft. Long.	Thickness or Diameter in Inches.	Weight of Square Bar 1 Ft. Long.	Weight of Round Bar 1 Ft. Long.
0			11/16	24.56	19.29	3/8	98.23	77.15
1/16	0.013	0.010	3/4	25.71	20.20	7/16	100.5	78.95
1/8	.053	.042	13/16	26.90	21.12	1/2	102.8	80.77
3/16	.119	.094	7/8	28.10	22.07	9/16	105.2	82.62
1/4	.212	.167	15/16	29.34	23.03	5/8	107.6	84.49
5/16	.333	.261	3	30.60	24.03	11/16	110.0	86.38
3/8	.478	.375	1/16	31.89	25.04	3/4	112.4	88.29
7/16	.651	.511	1/8	33.20	26.08	13/16	114.9	90.22
1/2	.850	.667	3/16	34.55	27.13	7/8	117.4	92.17
9/16	1.076	.845	1/4	35.91	28.20	15/16	119.9	94.14
5/8	1.328	1.043	5/16	37.31	29.30	6	122.4	96.14
11/16	1.608	1.262	3/8	38.73	30.42	1/8	127.6	100.2
3/4	1.913	1.502	7/16	40.18	31.56	1/4	132.8	104.3
13/16	2.245	1.763	1/2	41.65	32.71	3/8	138.2	108.5
7/8	2.603	2.044	9/16	43.15	33.89	1/2	143.6	112.8
15/16	2.989	2.347	5/8	44.68	35.09	5/8	149.2	117.2
1	3.400	2.670	11/16	46.24	36.31	3/4	154.9	121.7
1/16	3.838	3.014	3/4	47.82	37.56	7/8	160.8	126.2
1/8	4.303	3.379	13/16	49.42	38.81	7	166.6	130.9
3/16	4.795	3.766	7/8	51.05	40.10	1/8	172.6	135.6
1/4	5.312	4.173	15/16	52.71	41.40	1/4	178.7	140.4
5/16	5.857	4.600	4	54.40	42.73	3/8	184.9	145.2
3/8	6.428	5.049	1/16	56.11	44.07	1/2	191.3	150.2
7/16	7.026	5.518	1/8	57.85	45.44	5/8	197.7	155.2
1/2	7.650	6.008	3/16	59.62	46.83	3/4	204.2	159.3
9/16	8.301	6.520	1/4	61.41	48.24	7/8	210.8	165.6
5/8	8.978	7.051	5/16	63.23	49.66	8	217.6	171.0
11/16	9.682	7.604	3/8	65.08	51.11	1/4	231.4	181.8
3/4	10.41	8.178	7/16	66.95	52.58	1/2	245.6	193.0
13/16	11.17	8.773	1/2	68.85	54.07	3/4	260.3	204.4
7/8	11.95	9.388	9/16	70.78	55.59	9	275.4	216.3
15/16	12.76	10.02	5/8	72.73	57.12	1/4	290.9	228.5
2	13.60	10.68	11/16	74.70	58.67	1/2	306.8	241.0
1/16	14.46	11.36	3/4	76.71	60.25	3/4	323.2	253.9
1/8	15.35	12.06	13/16	78.74	61.84	10	340.0	267.0
3/16	16.27	12.78	7/8	80.80	63.46	1/4	357.2	280.6
1/4	17.22	13.52	15/16	82.89	65.10	1/2	374.9	294.4
5/16	18.19	14.28	5	85.00	66.76	3/4	392.9	308.6
3/8	19.18	15.07	1/16	87.14	68.44	11	411.4	323.1
7/16	20.20	15.86	1/8	89.30	70.14	1/4	430.3	337.9
1/2	21.25	16.69	3/16	91.49	71.86	1/2	449.6	353.1
9/16	22.33	17.53	1/4	93.72	73.60	3/4	469.4	368.6
5/8	23.43	18.40	5/16	95.96	75.37	12	489.6	384.5

**Weight of Fillets.**

Radius, In.	Area, Sq. In.	Weight per In., Lb.			Radius, In.	Area, Sq. In.	Weight per In., Lb.		
		Cast Iron.	Steel.	Brass.			Cast Iron.	Steel.	Brass.
1/4	0.0134	0.0035	0.0038	0.0040	13/16	0.1416	0.0369	0.0401	0.0414
5/16	.0209	.0054	.0059	.0061	7/8	.1634	.0428	.0465	.0479
3/8	.0302	.0078	.0085	.0088	15/16	.1886	.0491	.0534	.0550
7/16	.0411	.0107	.0116	.0120	1	.2146	.0559	.0608	.0626
1/2	.0536	.0140	.0152	.0157	1 1/8	.2716	.0709	.0771	.0794
9/16	.0679	.0177	.0192	.0200	1 1/4	.3353	.0874	.0950	.0979
5/8	.0834	.0218	.0237	.0244	1 3/8	.4057	.0920	.1000	.1030
11/16	.1014	.0264	.0287	.0300	1 1/2	.4828	.1259	.1368	.1410
3/4	.1207	.0315	.0342	.0352	1 5/8	.5668	.1479	.1608	.1657

*Continued on next page.*

**Weights per Lineal Inch of Round, Square and Hexagon Steel.**

Weight of 1 cu. in. = 0.2836 lb.

Weight of 1 cu. ft. = 490 lb.

Thick-ness or Diam-eter.	Round.	Square.	Hexagon.	Thick-ness or Diam-eter.	Round.	Square.	Hexagon.
1/32	0.0002	0.0003	0.0002	1 7/8	0.7831	0.9970	0.8635
1/16	.0009	.0011	.0010	1 15/16	.8361	1.0646	.9220
3/32	.0020	.0025	.0022	2	.8910	1.1342	.9825
1/8	.0035	.0044	.0038	2 1/16	.9475	1.2064	1.0448
5/32	.0054	.0069	.0060	2 1/8	1.0058	1.2806	1.1091
3/16	.0078	.0101	.0086	2 3/16	1.0658	1.3570	1.1753
7/32	.0107	.0136	.0118	2 1/4	1.1276	1.4357	1.2434
1/4	.0139	.0177	.0154	2 5/16	1.1911	1.5165	1.3135
9/32	.0176	.0224	.0194	2 3/8	1.2564	1.6569	1.3854
5/16	.0218	.0277	.0240	2 7/16	1.3234	1.6849	1.4593
11/32	.0263	.0335	.0290	2 1/2	1.3921	1.7724	1.5351
3/8	.0313	.0405	.0345	2 5/8	1.5348	1.9541	1.6924
13/32	.0368	.0466	.0405	2 3/4	1.6845	2.1446	1.8574
7/16	.0426	.0543	.0470	2 7/8	1.8411	2.3441	2.0304
15/32	.0489	.0623	.0540	3	2.0046	2.5548	2.2105
1/2	.0557	.0709	.0614	3 1/8	2.1752	2.7719	2.3986
17/32	.0629	.0800	.0693	3 1/4	2.3527	2.9954	2.5918
9/16	.0705	.0897	.0777	3 3/8	2.5371	3.2303	2.7977
19/32	.0785	.1036	.0866	3 1/2	2.7286	3.4740	3.0083
5/8	.0870	.1108	.0959	3 5/8	2.9269	3.7265	3.2275
21/32	.0959	.1221	.1058	3 3/4	3.1323	3.9880	3.4539
11/16	.1053	.1340	.1161	3 7/8	3.3446	4.2582	3.6880
23/32	.1151	.1465	.1270	4	3.5638	4.5374	3.9298
3/4	.1253	.1622	.1382	4 1/8	3.7900	4.8254	4.1792
25/32	.1359	.1732	.1499	4 1/4	4.0232	5.1223	4.4364
13/16	.1470	.1872	.1620	4 3/8	4.2634	5.4280	4.7011
27/32	.1586	.2019	.1749	4 1/2	4.5105	5.7426	4.9736
7/8	.1705	.2171	.1880	4 5/8	4.7645	6.0662	5.2538
29/32	.1829	.2329	.2015	4 3/4	5.0255	6.6276	5.5416
15/16	.1958	.2492	.2159	4 7/8	5.2935	6.7397	5.8371
31/32	.2090	.2661	.2305	5	5.5685	7.0897	6.1403
1	.2227	.2836	.2456	5 1/8	5.8504	7.4496	6.4511
1 1/16	.2515	.3201	.2773	5 1/4	6.1392	7.8164	6.7697
1 1/8	.2819	.3589	.3109	5 3/8	6.4351	8.1930	7.0959
1 3/16	.3141	.4142	.3464	5 1/2	6.7379	8.5786	7.4298
1 1/4	.3480	.4431	.3838	5 5/8	7.0476	8.9729	7.7713
1 5/16	.3837	.4885	.4231	5 3/4	7.3643	9.3762	8.1214
1 3/8	.4211	.5362	.4643	5 7/8	7.6880	9.7883	8.4774
1 7/16	.4603	.5860	.5076	6	8.0186	10.2192	8.8420
1 1/2	.5012	.6487	.5526	6 1/4	8.7007	11.0877	9.5943
1 9/16	.5438	.6930	.5996	6 1/2	9.4107	11.9817	10.3673
1 5/8	.5882	.7489	.6480	6 3/4	10.1485	12.9211	11.1908
1 11/16	.6343	.8076	.6994	7	10.9142	13.8960	12.0351
1 3/4	.6821	.8685	.7521	7 1/2	12.5291	15.9520	13.8158
1 13/16	.7317	.9316	.8069	8	14.2553	18.1497	15.7192

**Weight of Fillets.—Continued from page 185.**

Ra-dius, In.	Area, Sq. In.	Weight per In., Lb.			Ra-dius, In.	Area, Sq. In.	Weight per In., Lb.		
		Cast Iron.	Steel.	Brass.			Cast Iron.	Steel.	Brass.
1 3/4	0.6572	0.1713	0.1862	0.1920	2 7/8	1.774	0.4621	0.5022	0.5017
1 7/8	.7545	.1970	.2137	.2202	3	1.931	.4950	.5471	.5635
2	.8585	.2237	.2431	.2504	3 1/4	2.267	.5903	.6417	.6609
2 1/8	.9692	.2502	.2743	.2826	3 1/2	2.629	.6926	.7438	.7661
2 1/4	1.086	.2832	.3079	.3172	3 3/4	3.018	.7873	.8523	.8817
2 3/8	1.210	.3155	.3429	.3532	4	3.434	.8933	.9709	1.000
2 1/2	1.341	.3496	.3800	.3914	4 1/4	3.876	1.008	1.096	1.130
2 5/8	1.478	.3857	.4192	.4317	4 1/2	4.346	1.132	1.231	1.270
2 3/4	1.623	.4222	.4589	.4727	4 3/4	4.842	1.261	1.371	1.421



**WEIGHT OF PLATE IRON, PER LINEAL FOOT, IN POUNDS.**

(Based on 480 lbs. per Cubic Foot. For Steel add 2 per cent.)

Thickness in Inches.

Width in Inches.	1/16	1/8	3/16	1/4	5/16	3/8	7/16	1/2	9/16	5/8	11/16	3/4	13/16	7/8	15/16	1
12	2.50	5.00	7.50	10.00	12.50	15.00	17.50	20.00	22.50	25.00	27.50	30.00	32.50	35.00	37.50	40.00
13	2.71	5.42	8.13	10.83	13.54	16.25	18.96	21.67	24.38	27.08	29.79	32.50	35.21	37.92	40.63	43.33
14	2.92	5.83	8.75	11.67	14.58	17.50	20.42	23.33	26.25	29.17	32.08	35.00	37.92	40.83	43.75	46.67
15	3.13	6.25	9.38	12.50	15.63	18.75	21.88	25.00	28.13	31.25	34.38	37.50	40.63	43.75	46.88	50.00
16	3.33	6.67	10.00	13.33	16.67	20.00	23.33	26.67	30.00	33.33	36.67	40.00	43.33	46.67	50.00	53.33
17	3.54	7.08	10.63	14.17	17.71	21.25	24.79	28.33	31.88	35.42	38.96	42.50	46.05	49.59	53.13	56.67
18	3.75	7.50	11.25	15.00	18.75	22.50	26.25	30.00	33.75	37.50	41.25	45.00	48.75	52.50	56.25	60.00
19	3.96	7.92	11.87	15.83	19.79	23.75	27.71	31.67	35.67	39.58	43.54	47.50	51.45	55.41	59.37	63.33
20	4.17	8.33	12.50	16.67	20.83	25.00	29.17	33.33	37.50	41.67	45.83	50.00	54.17	58.33	62.50	66.67
21	4.38	8.75	13.13	17.50	21.88	26.25	30.63	35.00	39.38	43.75	48.13	52.50	56.88	61.25	65.63	70.00
22	4.58	9.17	13.75	18.33	22.92	27.50	32.08	36.67	41.25	45.83	50.42	55.00	59.58	64.17	68.75	73.33
23	4.79	9.58	14.38	19.17	23.96	28.75	33.54	38.33	43.13	47.92	52.71	57.50	62.30	67.09	71.88	76.67
24	5.00	10.00	15.00	20.00	25.00	30.00	35.00	40.00	45.00	50.00	55.00	60.00	65.00	70.00	75.00	80.00
25	5.21	10.42	15.62	20.83	26.04	31.25	36.46	41.67	46.88	52.08	57.29	62.50	67.70	72.91	78.13	83.33
26	5.42	10.83	16.25	21.67	27.08	32.50	37.92	43.33	48.75	54.17	59.58	65.00	70.42	75.83	81.25	86.67
27	5.63	11.25	16.88	22.50	28.13	33.75	39.38	45.00	50.63	56.25	61.88	67.50	73.13	78.75	84.38	90.00
28	5.83	11.67	17.50	23.33	29.17	35.00	40.83	46.67	52.50	58.33	64.17	70.00	75.84	81.67	87.50	93.33
29	6.04	12.08	18.13	24.17	30.21	36.25	42.29	48.33	54.38	60.42	66.46	72.50	78.55	84.59	90.63	96.67
30	6.25	12.50	18.75	25.00	31.25	37.50	43.75	50.00	56.25	62.50	68.75	75.00	81.25	87.50	93.75	100.0
32	6.67	13.33	20.00	26.67	33.33	40.00	46.67	53.33	60.00	66.67	73.33	80.00	86.67	93.33	100.0	106.7
34	7.03	14.17	21.25	28.33	35.42	42.50	49.58	56.67	63.75	70.83	77.91	85.00	92.08	99.17	106.3	113.3
36	7.50	15.00	22.50	30.00	37.50	45.00	52.50	60.00	67.50	75.00	82.50	90.00	97.50	105.0	112.5	120.0
38	7.92	15.83	23.75	31.67	39.59	47.50	55.42	63.33	71.25	79.17	87.09	95.00	102.9	110.8	118.8	126.7
40	8.33	16.67	25.00	33.33	41.67	50.00	58.33	66.67	75.00	83.33	91.67	100.0	108.3	116.7	125.0	133.3
42	8.75	17.50	26.25	35.00	43.75	52.50	61.25	70.00	78.75	87.50	96.25	105.0	113.7	122.5	131.3	140.0
44	9.17	18.33	27.50	36.67	45.84	55.00	64.17	73.33	82.50	91.67	100.8	110.0	119.2	128.3	137.5	146.7
46	9.58	19.17	28.75	38.33	47.92	57.50	67.08	76.67	86.25	95.83	105.4	115.0	124.6	134.2	143.8	153.3
48	10.00	20.00	30.00	40.00	50.00	60.00	70.00	80.00	90.00	100.0	110.0	120.0	130.0	140.0	150.0	160.0
50	10.42	20.83	31.25	41.67	52.08	62.50	72.91	83.33	93.75	104.2	114.6	125.0	135.4	145.8	156.3	166.7
52	10.83	21.67	32.50	43.33	54.17	65.00	75.83	86.67	97.50	108.3	119.2	130.0	140.8	151.7	162.5	173.3
54	11.25	22.50	33.75	45.00	56.25	67.50	78.75	90.00	101.3	112.5	123.8	135.0	146.3	157.5	168.8	180.0
56	11.67	23.33	35.00	46.67	58.33	70.00	81.66	93.33	105.0	116.7	128.3	140.0	151.7	163.3	175.0	186.7
58	12.08	24.17	36.25	48.33	60.42	72.50	84.58	96.67	108.8	120.8	132.9	145.0	157.1	169.2	181.3	193.3
60	12.50	25.00	37.50	50.00	62.50	75.00	87.50	100.00	112.5	125.0	137.5	150.0	162.5	175.0	187.5	200.0

**WEIGHTS OF FLAT ROLLED IRON IN POUNDS PER LINEAL FOOT.**

Iron weighing 480 lbs. per cubic foot. For steel add 2 per cent.

Thick- ness in Inches.	Widths.															
	1".	1 1/4".	1 1/2".	1 3/4".	2".	2 1/4".	2 1/2".	2 3/4".	3".	3 1/4".	3 1/2".	3 3/4".	4".	4 1/4".	4 1/2".	4 3/4".
1/16	0.208	0.260	0.313	0.365	0.417	0.469	0.521	0.573	0.625	0.677	0.729	0.781	0.833	0.885	0.938	0.990
1/8	.417	.521	.625	.729	.833	.938	1.04	1.15	1.25	1.35	1.46	1.56	1.67	1.77	1.88	1.98
3/16	.625	.781	.938	1.09	1.25	1.41	1.56	1.72	1.88	2.03	2.19	2.34	2.50	2.66	2.81	2.97
1/4	.833	1.04	1.25	1.46	1.67	1.88	2.08	2.29	2.50	2.71	2.92	3.13	3.33	3.54	3.75	3.96
5/16	1.04	1.30	1.56	1.82	2.08	2.34	2.60	2.86	3.13	3.39	3.65	3.91	4.17	4.43	4.69	4.95
3/8	1.25	1.56	1.88	2.19	2.50	2.81	3.13	3.44	3.75	4.06	4.38	4.69	5.00	5.31	5.63	5.94
7/16	1.46	1.82	2.19	2.55	2.92	3.28	3.65	4.01	4.38	4.74	5.10	5.47	5.83	6.20	6.56	6.93
1/2	1.67	2.08	2.50	2.92	3.33	3.75	4.17	4.58	5.00	5.42	5.83	6.25	6.67	7.08	7.50	7.92
9/16	1.88	2.34	2.81	3.28	3.75	4.22	4.69	5.16	5.63	6.09	6.56	7.03	7.50	7.97	8.44	8.91
5/8	2.08	2.60	3.13	3.65	4.17	4.69	5.21	5.73	6.25	6.77	7.29	7.81	8.33	8.85	9.38	9.90
11/16	2.29	2.86	3.44	4.01	4.58	5.16	5.73	6.30	6.88	7.45	8.02	8.59	9.17	9.74	10.31	10.89
3/4	2.50	3.13	3.75	4.38	5.00	5.63	6.25	6.88	7.50	8.13	8.75	9.38	10.00	10.63	11.25	11.88
7/8	2.71	3.39	4.06	4.74	5.42	6.09	6.77	7.45	8.13	8.80	9.48	10.16	10.83	11.51	12.19	12.86
15/16	2.92	3.65	4.38	5.10	5.83	6.56	7.29	8.02	8.75	9.48	10.21	10.94	11.67	12.40	13.13	13.85
1	3.13	3.91	4.69	5.47	6.25	7.03	7.81	8.59	9.38	10.16	10.94	11.72	12.50	13.28	14.06	14.83
1 1/16	3.33	4.17	5.00	5.83	6.67	7.50	8.33	9.17	10.00	10.83	11.67	12.50	13.33	14.17	15.00	15.83
1 1/8	3.54	4.43	5.31	6.20	7.08	7.97	8.85	9.74	10.63	11.51	12.40	13.28	14.17	15.05	15.94	16.82
1 1/4	3.75	4.69	5.63	6.56	7.50	8.44	9.38	10.31	11.25	12.19	13.13	14.06	15.00	15.94	16.88	17.81
1 1/2	3.96	4.95	5.94	6.93	7.92	8.91	9.90	10.89	11.88	12.86	13.85	14.84	15.83	16.82	17.81	18.80
1 3/4	4.17	5.21	6.25	7.29	8.33	9.38	10.42	11.46	12.50	13.54	14.58	15.63	16.67	17.71	18.75	19.79
1 5/8	4.37	5.47	6.56	7.66	8.75	9.84	10.94	12.03	13.13	14.22	15.31	16.41	17.50	18.59	19.69	20.78
1 3/8	4.58	5.73	6.88	8.02	9.17	10.31	11.46	12.60	13.75	14.90	16.04	17.19	18.33	19.48	20.63	21.77
1 7/16	4.79	5.99	7.19	8.39	9.58	10.78	11.98	13.18	14.38	15.57	16.77	17.97	19.17	20.36	21.56	22.76
1 1/2	5.00	6.25	7.50	8.75	10.00	11.25	12.50	13.75	15.00	16.25	17.50	18.75	20.00	21.25	22.50	23.75
1 9/16	5.21	6.51	7.81	9.11	10.42	11.72	13.02	14.32	15.63	16.93	18.23	19.53	20.83	22.14	23.44	24.74
1 5/8	5.42	6.77	8.13	9.48	10.83	12.19	13.54	14.90	16.25	17.60	18.96	20.31	21.67	23.02	24.38	25.73
1 11/16	5.63	7.03	8.44	9.84	11.25	12.66	14.06	15.47	16.88	18.28	19.69	21.09	22.50	23.91	25.31	26.72
1 3/4	5.83	7.29	8.75	10.21	11.67	13.13	14.58	16.04	17.50	18.96	20.42	21.88	23.33	24.79	26.25	27.71
1 13/16	6.04	7.55	9.06	10.57	12.08	13.59	15.10	16.61	18.13	19.64	21.15	22.66	24.17	25.68	27.19	28.70
1 7/8	6.25	7.81	9.38	10.94	12.50	14.06	15.63	17.19	18.75	20.31	21.88	23.44	25.00	26.56	28.13	29.69
1 15/16	6.46	8.07	9.69	11.30	12.92	14.53	16.15	17.76	19.38	20.99	22.60	24.22	25.83	27.45	29.06	30.68
2	6.67	8.33	10.00	11.67	13.33	15.00	16.67	18.33	20.00	21.67	23.33	25.00	26.67	28.33	30.00	31.67

Thickness in Inches.	Widths.															
	5".	5 1/4".	5 1/2".	5 3/4".	6".	6 1/4".	6 1/2".	6 3/4".	7".	7 1/2".	8".	8 1/2".	9".	10".	11".	12".
1/16	1.04	1.09	1.15	1.20	1.25	1.30	1.35	1.41	1.46	1.56	1.67	1.77	1.88	2.08	2.29	2.50
1/8	2.08	2.19	2.29	2.40	2.50	2.60	2.71	2.81	2.92	3.13	3.33	3.54	3.75	4.17	4.58	5.00
3/16	3.13	3.28	3.44	3.59	3.75	3.91	4.06	4.22	4.38	4.69	5.00	5.31	5.63	6.25	6.88	7.50
1/4	4.17	4.38	4.58	4.79	5.00	5.21	5.42	5.63	5.83	6.25	6.67	7.08	7.50	8.33	9.17	10.00
5/16	5.21	5.47	5.73	5.99	6.25	6.51	6.77	7.03	7.29	7.81	8.33	8.85	9.38	10.42	11.46	12.50
3/8	6.25	6.56	6.88	7.19	7.50	7.81	8.13	8.44	8.75	9.38	10.00	10.63	11.25	12.50	13.75	15.00
7/16	7.29	7.66	8.02	8.39	8.75	9.11	9.48	9.84	10.21	10.94	11.67	12.40	13.13	14.58	16.04	17.50
1/2	8.33	8.75	9.17	9.58	10.00	10.42	10.83	11.25	11.67	12.50	13.33	14.17	15.00	16.67	18.33	20.00
9/16	9.38	9.84	10.31	10.78	11.25	11.72	12.19	12.66	13.13	14.06	15.00	15.94	16.88	18.75	20.63	22.50
5/8	10.42	10.94	11.46	11.98	12.50	13.02	13.54	14.06	14.58	15.63	16.67	17.71	18.75	20.83	22.92	25.00
11/16	11.46	12.03	12.60	13.18	13.75	14.32	14.90	15.47	16.04	17.19	18.33	19.48	20.63	22.92	25.21	27.50
3/4	12.50	13.13	13.75	14.38	15.00	15.63	16.25	16.88	17.50	18.75	20.00	21.25	22.50	25.00	27.50	30.00
13/16	13.54	14.22	14.90	15.57	16.25	16.93	17.60	18.28	18.96	20.31	21.67	23.02	24.38	27.08	29.79	32.50
7/8	14.58	15.31	16.04	16.77	17.50	18.23	18.96	19.69	20.42	21.88	23.33	24.79	26.25	29.17	32.08	35.00
15/16	15.63	16.41	17.19	17.97	18.75	19.53	20.31	21.09	21.88	23.44	25.00	26.56	28.13	31.25	34.38	37.50
1	16.67	17.50	18.33	19.17	20.00	20.83	21.67	22.50	23.33	25.00	26.67	28.33	30.00	33.33	36.67	40.00
11/8	18.75	19.69	20.63	21.56	22.50	23.44	24.38	25.31	26.25	28.13	30.00	31.88	33.75	37.50	41.25	45.00
1 1/4	20.83	21.88	22.92	23.96	25.00	26.04	27.08	28.13	29.17	31.25	33.33	35.42	37.50	41.67	45.83	50.00
1 3/8	22.92	24.06	25.21	26.35	27.50	28.65	29.79	30.94	32.08	34.38	36.67	38.96	41.25	45.83	50.42	55.00
1 1/2	25.00	26.25	27.50	28.75	30.00	31.25	32.50	33.75	35.00	37.50	40.00	42.50	45.00	50.00	55.00	60.00
1 5/8	27.08	28.44	29.79	31.15	32.50	33.85	35.21	36.56	37.92	40.63	43.33	46.04	48.75	54.17	59.58	65.00
1 3/4	29.17	30.63	32.08	33.54	35.00	36.46	37.92	39.38	40.83	43.75	46.67	49.58	52.50	58.33	64.17	70.00
1 7/8	31.25	32.81	34.38	35.94	37.50	39.06	40.63	42.19	43.75	46.88	50.00	53.13	56.25	62.50	68.75	75.00
2	33.33	35.00	36.67	38.33	40.00	41.67	43.33	45.00	46.67	50.00	53.33	56.67	60.00	66.67	73.33	80.00

Other sizes. — Weight of other sizes can easily be obtained from the above table by means of combinations or divisions. Thus, for example,

- Weight of 12 X 1 1/4 equals weight of 12 X 1 plus weight of 12 X 1/4..... 50.00
- Or, twice weight of 12 X 5/8, as it is twice as thick..... 50.00
- Weight of 6 X 15/16 equals midway weight between 6 X 17/8 and 6 X 2..... 38.75
- Weight of 24 X 15/16, being twice as wide as 12 X 15/16, weights..... 75.00

## WEIGHTS OF STEEL BLOOMS.

Soft steel. 1 cubic inch = 0.284 lb. 1 cubic foot = 490.75 lbs.

Size, Inches	Lengths.												
	1"	6"	12"	18"	24"	30"	36"	42"	48"	54"	60"	66"	
12	×6	20.45	123	245	363	491	613	736	859	982	1104	1227	1350
	×5	17.04	102	204	307	409	511	613	716	818	920	1022	1125
	×4	13.63	82	164	245	327	409	491	573	654	736	818	900
11	×6	18.75	113	225	338	450	563	675	788	900	1013	1125	1238
	×5	15.62	94	188	281	375	469	562	656	750	843	937	1031
	×4	12.50	75	150	225	300	375	450	525	600	675	750	825
10	×8	22.72	136	273	409	545	682	818	954	1091	1227	1363	1500
	×7	19.88	120	239	358	477	596	715	835	955	1074	1193	1312
	×6	17.04	102	204	307	409	511	613	716	818	920	1022	1125
	×5	14.20	85	170	256	341	426	511	596	682	767	852	937
	×4	11.36	68	136	205	273	341	409	477	546	614	682	750
	×3	8.52	51	102	153	204	255	306	358	409	460	511	562
9	×8	20.45	123	245	368	491	613	736	859	982	1104	1227	1350
	×7	17.89	107	215	322	430	537	644	751	859	966	1073	1181
	×6	15.34	92	184	276	368	460	552	644	736	828	920	1012
	×5	12.78	77	153	230	307	383	460	537	614	690	767	844
	×4	10.22	61	123	184	245	307	368	429	490	552	613	674
	×3	7.66	46	92	138	184	230	276	322	368	414	460	506
8	×8	18.18	109	218	327	436	545	655	764	873	982	1091	1200
	×7	15.9	95	191	286	382	477	572	668	763	859	954	1049
	×6	13.63	82	164	245	327	409	491	573	654	736	818	900
	×5	11.36	68	136	205	273	341	409	477	546	614	682	750
	×4	9.09	55	109	164	218	273	327	382	436	491	545	600
	×3	6.82	41	82	123	164	204	245	286	327	368	409	450
7	×7	13.92	83	167	251	334	418	501	585	668	752	835	919
	×6	11.93	72	143	215	286	358	430	501	573	644	716	788
	×5	9.94	60	119	179	238	298	358	417	477	536	596	656
	×4	7.95	48	96	143	191	239	286	334	382	429	477	525
	×3	5.96	36	72	107	143	179	214	250	286	322	358	393
6 1/2	×6 1/2	12.	72	144	216	288	360	432	504	576	648	720	792
	×4	7.38	44	89	133	177	221	266	310	354	399	443	487
6	×6	10.22	61	123	184	245	307	368	429	490	551	613	674
	×5	8.52	51	102	153	204	255	307	358	409	460	511	562
	×4	6.82	41	82	123	164	204	245	286	327	368	409	450
	×3	5.11	31	61	92	123	153	184	214	245	276	307	337
5 1/2	×5 1/2	8.59	52	103	155	206	258	309	361	412	464	515	567
	×4	6.25	37	75	112	150	188	225	262	300	337	375	412
5	×5	7.10	43	85	128	170	213	256	298	341	383	426	469
	×4	5.68	34	68	102	136	170	205	239	273	307	341	375
4 1/2	×4 1/2	5.75	35	69	104	138	173	207	242	276	311	345	380
	×4	5.11	31	61	92	123	153	184	215	246	276	307	338
4	×4	4.54	27	55	82	109	136	164	191	218	246	272	300
	×3 1/2	3.97	24	48	72	96	119	143	167	181	215	238	262
	×3	3.40	20	41	61	82	102	122	143	163	184	204	224
3 1/2	×3 1/2	3.48	21	42	63	84	104	125	146	167	188	209	230
	×3	2.98	18	36	54	72	89	107	125	143	161	179	197
3	×3	2.56	15	31	46	61	77	92	108	123	138	154	169



**ROOFING MATERIALS AND ROOF CONSTRUCTION.**

**Approximate Weight of Roofing Materials.**

(American Sheet & Tin Plate Co.)

Material.	Lb. per sq. ft.
Corrugated galvanized iron, No. 20, unboarded . . . . .	2 1/4
Copper, 16 oz. standing seam . . . . .	1 1/4
Felt and asphalt, without sheathing . . . . .	2
Glass, 1/8 in. thick . . . . .	1 3/4
Hemlock sheathing, 1 in. thick . . . . .	2
Lead, about 1/8 in. thick . . . . .	6 to 8
Lath and plaster ceiling (ordinary) . . . . .	6 to 8
Mackite, 1 in. thick, with plaster . . . . .	10
Neponset roofing, felt, 2 layers . . . . .	1/2
Spruce sheathing, 1 in. thick . . . . .	2 1/2
Slate, 3/16 in. thick, 3 in. double lap . . . . .	6 3/4
Slate, 1/8 in. thick, 3 in. double lap . . . . .	4 1/2
Shingles, 6 in. × 18 in., 1/3 to weather . . . . .	2
Skylight of glass, 3/16 to 1/2 in., including frame . . . . .	4 to 10
Slag roof, 4-ply . . . . .	4
Terne plate, IC, without sheathing . . . . .	1/2
Terne plate, IX, without sheathing . . . . .	5/8
Tiles (plain), 10 1/2 in. × 6 1/4 in. × 5/8 in. — 5 1/4 in. to weather . . . . .	18
Tiles (Spanish), 14 1/2 in. × 10 1/2 in. — 7 1/4 in. to weather . . . . .	8 1/2
White pine sheathing, 1 in. thick . . . . .	2 1/2
Yellow pine sheathing, 1 in. thick . . . . .	4

**Snow and Wind Loads on Roofs.**

In designing roofs, in addition to the weight of roofing material to be supported, recognition must be given to possible snow and wind loads.

In snowy localities the minimum snow load per horizontal sq. ft. of roof should be considered as 25 lb. for slopes up to 20 degrees. For each degree increase in slope up to 45 degrees, this load may be reduced 1 lb. Above 45-degree slope no snow load need be considered. In especially severe climates these allowances should be increased in accordance with actual conditions.

The wind load is the pressure normal to the surface of the roof produced by a wind blowing horizontally. The wind pressure against a vertical plane as determined by the U. S. Signal Service at Mt. Washington, N. H., is for various velocities of wind:

Velocity, miles per hr. . . . .	10	20	30	40	50	60	80	100
Pressure, lb. per sq. ft. . . . .	0.4	1.6	3.6	6.4	10.0	14.4	25.6	40.0

The pressure on a flat surface is twice that on a cylindrical surface of the same projected area. For further information regarding wind pressure, see page 626. As the slope of the roof increases, the greater becomes the wind pressure on it. The pressure normal to the surface of roofs of different slopes exerted by a wind velocity of 100 miles per hour (40 lb. per sq. ft. on a vertical plane) is

Rise, in. per ft. . . . .	4	6	8	12	16	18	24
Angle with horizontal . . . . .	18° 26'	26° 34'	33° 41'	45° 0'	53° 8'	56° 19'	63° 26'
Pitch (Rise ÷ Span) . . . . .	1/6	1/4	1/3	1/2	2/3	3/4	1
Wind pressure . . . . .	16.8	23.7	29.1	36.1	38.7	39.3	40.0

**Roof Construction.** (N. G. Taylor Co., Philadelphia.)—Roofs with less than 1/3 pitch are made with flat seams, and should preferably be covered with 14 × 20 in. sheets, rather than with 20 × 28-in. sheets, as the larger number of seams tend to stiffen the surface and prevent buckles. For a flat seam roof the edges of the sheets are turned 1/2 in., locked together and soldered. The sheets are fastened to the sheath-

ing boards by cleats 8 in. apart and locked in the seams. Two 1-in. barbed and tinned nails are driven in each cleat. Steep tin roofs should be made with standing seams and from 28 X 20-in. sheets. The sheets are first single or double seamed and soldered together in a long strip reaching from eave to ridge. The sloping seams are composed of two "upstands" interlocked at the upper edge and held to the sheathing boards by cleats. No solder is used in standing seams as a rule. In soldering tin roofs, only a good rosin flux should be used. The use of acid must be carefully avoided.

**Roof Paints.**—The American Sheet and Tin Plate Co. recommends for painting metal work and tin roofs metallic brown, venetian red, or red oxide paint, ground in pure linseed oil. The paint should be rubbed well in, and should not be spread thin. See also Preservative Coatings, page 471.

**Tin Plates** are made of soft sheet steel coated with tin, and are called in the trade "coke" or "charcoal" plates according to the weight of coating. These terms have survived from the time when the highest quality of plate was made from charcoal-iron, while the lower grades were made from coke-iron. Consequently, plates to-day with the lighter coatings are known as coke-plates, and are used for tin cans, etc. The various grades of charcoal-plates are designated by the letters A to AAAAA, the latter having the heaviest coating and the highest polish. There is one other brand made with a heavier coating than 5A, which is especially adapted for nickel-plating. The unit of value and measurement of tin plates is the "base-box," which will hold 112 sheets of 14 X 20 in. plate, or 31360 sq. in. of any size. Plates lighter than 65 lb. per base-box (No. 36 gage) are known as taggers tin.

**Weights of Standard Galvanized Sheets.**

(American Sheet & Tin Plate Co.)

Gage.	Oz. per Sq. ft.	Lb. per Sq. ft.	Gage.	Oz. per Sq. ft.	Lb. per Sq. ft.	Gage.	Oz. per Sq. ft.	Lb. per Sq. ft.	Gage.	Oz. per Sq. ft.	Lb. per Sq. ft.
8	112.5	7.031	15	47.5	2.969	22	22.5	1.406	29	11.5	0.719
9	102.5	6.406	16	42.5	2.656	23	20.5	1.281	30	10.5	.656
10	92.5	5.781	17	38.5	2.406	24	18.5	1.156	31	9.5	.594
11	82.5	5.156	18	34.5	2.156	25	16.5	1.031	32	9.0	.563
12	72.5	4.531	19	30.5	1.906	26	14.5	0.906	33	8.5	.531
13	62.5	3.906	20	26.5	1.656	27	13.5	.844	34	8.0	.500
14	52.5	3.281	21	24.5	1.531	28	12.5	.781	.....	.....	.....

**Standard Weights and Gages of Tin Plate.**

(American Sheet & Tin Plate Co., Pittsburgh.)

Trade Term.	Nearest Wire Gage No.	Wt. per Sq. Ft., lb.	Wt. of Box 14 X 20 in., lb.	Trade Term.	Nearest Wire Gage No.	Wt. per Sq. Ft., lb.	Wt. of Box 14 X 20 in., lb.	Trade Term.	Nearest Wire Gage No.	Wt. per Sq. Ft., lb.	Wt. of box 14 X 20 in., lb.
55 lb.	38	0.252	55	100lb.	30 <sup>1</sup> / <sub>2</sub>	0.459	100	3XL	26	0.771	168
60 "	37	.275	60	IC	30	.491	107	DX	26	.826	180
65 "	36	.298	65	118lb.	29	.542	118	4X	25	.895	195
70 "	35	.321	70	IX	28	.619	135	4XL	25	.863	188
75 "	34	.344	75	IXL	28	.588	128	D2X	24	.964	210
80 "	33	.367	80	DC	28	.638	139	D3X	23	1.102	240
85 "	32	.390	85	2X	27	.711	155	D4X	22	1.239	270
90 "	31	.413	90	2XL	27	.679	148	.....	.....	.....	.....
95 "	31	.436	95	3X	26	.803	175	.....	.....	.....	.....

Sizes and Net Weight per Box of 100 lb. (0.459 lb. per sq. ft.)  
Tin Plates.

Size of Sheets.	Sheets per Box.	Weight per Box.	Size of Sheets.	Sheets per Box.	Weight per Box.	Size of Sheets.	Sheets per Box.	Weight per Box.
10 × 14	225	100	15 × 15	225	161	14 × 31	112	155
14 × 20	112	100	16 × 16	225	183	11 1/4 × 22 3/4	112	91
20 × 28	112	200	17 × 17	225	206	13 1/4 × 17 3/4	112	84
10 × 20	225	143	18 × 18	112	116	13 1/4 × 19 1/4	112	91
11 × 22	225	172	19 × 19	112	129	13 1/2 × 19 1/2	112	94
11 1/2 × 23	225	189	20 × 20	112	143	13 1/2 × 19 3/4	112	95
12 × 12	225	103	21 × 21	112	158	14 × 18 3/4	124	103
12 × 24	112	103	22 × 22	112	172	14 × 19 1/4	120	103
13 × 13	225	121	23 × 23	112	189	14 × 21	112	105
13 × 26	112	121	24 × 24	112	204	14 × 22	112	110
14 × 14	225	140	26 × 26	112	241	14 × 22 1/4	112	111
14 × 28	112	140	16 × 20	112	114	15 1/2 × 23	112	127

For weight per box of other than 100-lb. plates multiply by the figures in the column "Weight per Box" in the preceding table, and divide by 100. Thus for IX plates 20 × 28 in., 200 × 135 ÷ 100 = 270.

Sheets Required for Tin Roofing.

(American Sheet & Tin Plate Co., 1914.)

No. of Sq. Ft.	Sheets Required.		No. of Sq. Ft.	Sheets Required.		No. of Sq. Ft.	Sheets Required.		No. of Sq. Ft.	Sheets Required.				
	Flat Seam 14 × 20 Pl.	Stand. Seam 20 × 28 Pl.		Flat Seam 14 × 20 Pl.	Stand. Seam 20 × 28 Pl.		Flat Seam 14 × 20 Pl.	Stand. Seam 20 × 28 Pl.		Flat Seam 14 × 20 Pl.	Stand. Seam 20 × 28 Pl.			
100	59	31	280	164	86	460	269	141	640	374	197	820	479	252
110	65	34	290	170	89	470	275	144	650	379	200	830	484	255
120	70	37	300	175	92	480	280	148	660	385	203	840	490	258
130	76	40	310	181	95	490	286	151	670	391	206	850	496	261
140	82	43	320	187	99	500	292	154	680	397	209	860	502	264
150	88	46	330	193	102	510	298	157	690	403	212	870	508	267
160	94	50	340	199	105	520	304	160	700	409	215	880	514	270
170	100	53	350	205	108	530	309	163	710	414	218	890	519	273
180	105	56	360	210	111	540	315	166	720	420	221	900	525	276
190	111	59	370	216	114	550	321	169	730	426	224	910	531	279
200	117	62	380	222	117	560	327	172	740	432	227	920	537	282
210	123	65	390	228	120	570	333	175	750	438	230	930	543	285
220	129	68	400	234	123	580	339	178	760	444	233	940	549	288
230	135	71	410	240	126	590	344	181	770	449	236	950	554	291
240	140	74	420	245	129	600	350	184	780	455	239	960	560	295
250	146	77	430	251	132	610	356	187	790	461	243	970	566	298
260	152	80	440	257	135	620	362	190	800	467	246	980	572	301
270	158	83	450	263	138	630	368	194	810	473	249	990	578	304

**Terne Plates, or Roofing Tin,** are coated with an alloy of tin and lead. In the "U. S. Eagle, N.M." brand the alloy is 32% tin, 68% lead. The weight per 112 sheets of this brand before and after coating is as follows:

	IC 14 × 20	IC 20 × 28	IX 14 × 20	IX 20 × 28
Black plates . . .	95 to 100 lb.	190 to 200 lb.	125 to 130 lb.	250 to 260 lb.
After coating . . .	115 to 120	230 to 240	145 to 150	290 to 300

Terne plates are made in two thicknesses: IC, in which the iron body weighs about 50 lb. per 100 sq. ft., and IX, in which it weighs 62 1/2 lb. per 100 sq. ft. The IC grade is preferred for roofing, while the IX

grade is used for spouts, valleys, gutters, and flashings. The standard weight of 14 × 20 in. IC plates is 107 lb. per base-box, and of 14 × 20 in. IX plate 135 lb.

Long terne sheets are made in gages, Nos. 14 to 32, from 10 to 40 in. wide and up to 120 in. long. They are made in five grades with coatings of 8, 12, 15, 20, and 25 lb.

A box of 112 sheets 14 × 20 in. will cover approximately 192 sq. ft. of roof, flat seam, or 583 sheets 1000 sq. ft. For standing seam roofing a sheet 20 × 28 in. will cover 475 sq. in., or 303 sheets 1000 sq. ft. A box of 112 sheets 20 × 28 in. will cover approximately 366 sq. ft.

The common sizes of tin plates are 10 × 14 in. and multiples of that measure. The sizes most generally used are 14 × 20 and 20 × 28 in.

**Specifications for Tin and Terne Plate.** (Penna. R.R., 1903.)

	Material Desired.			Rejected if less than		
	Tin Plate.	No. 1 Terne.	No. 2 Terne.	Tin Plate.	No. 1 Terne.	No. 2 Terne.
Coating:						
Tin, per cent.....	100	26	16	.....	.....	.....
Lead, per cent.....	0	74	84	.....	.....	.....
Amount per sq. ft., lb..	0.023	0.046	0.023	0.0183	0.0413	0.083
Weight, lb. per sq. ft. of						
Grade IC.....	0.496	0.519	0.496	0.468	0.490	0.468
Grade IX.....	.625	.648	.625	.590	.612	.590
Grade IXX.....	.716	.739	.716	.676	.699	.676
Grade IXXX.....	.808	.831	.808	.763	.787	.763
Grade IXXXX.....	.900	.923	.900	.850	.874	.850

Each sheet in a shipment of tin or terne plate must (1) be cut as nearly exact to size ordered as possible; (2) must be rectangular, flat, and free from flaws; (3) must double seam successfully under reasonable treatment; (4) must show a smooth edge with no sign of fracture when bent through an angle of 180 degrees and flattened down with a wooden mallet; (5) must be so nearly like every other sheet in the shipment, both in thickness and in uniformity and amount of coating, that no difficulty will arise in the shops due to varying thickness of sheets.

**Corrugated Sheets.—Weight per 100 Sq. Ft., Lb.**

(American Sheet & Tin Plate Co., Pittsburgh, 1914.)

Corrugations.	5/8 in.		1 1/4 in.		2 in.		2 1/2 in.* 26 in. wide.		2 1/2 in.† 27 1/2 in. wide.		3 in.		5 in.	
	Painted	Galvan-ized.	Painted	Galvan-ized.	Painted	Galvan-ized.	Painted	Galvan-ized.	Painted	Galvan-ized.	Painted	Galvan-ized.	Painted	Galvan-ized.
U. S. Std. Sheet Metal Gage.														
29	...	81	...	81	...	77	...	77	...	78	...	77	...	77
28	71	88	71	88	68	84	68	84	69	85	68	84	68	84
27	78	95	78	95	75	91	75	91	76	92	75	91	75	91
26	85	102	85	102	82	98	82	98	83	99	82	98	81	97
25	99	116	99	116	95	111	95	111	97	113	95	111	95	111
24	113	130	113	130	109	125	109	125	110	126	109	125	108	124
23	...	...	127	144	122	138	122	138	124	140	122	138	122	137
22	...	...	141	158	136	151	136	151	137	153	136	151	135	151
21	...	...	155	172	149	165	149	165	151	167	149	165	148	164
20	...	...	169	186	163	178	163	178	165	181	163	178	162	178
18	...	...	...	...	216	232	216	232	219	235	216	232	215	231
16	...	...	...	...	270	286	270	286	274	290	270	286	269	285
14	...	...	...	...	...	...	338	353	342	358	338	353	336	352
12	...	...	...	...	...	...	472	488	478	494	472	488	470	486
10	...	...	...	...	...	...	607	623	615	631	...	...	...	...

\* Siding. † Roofing.



Covering width of plates, lapped one corrugation, 24 in. Standard lengths, 5, 6, 7, 8, 9, and 10 ft.; maximum length, 12 ft.

Ordinary corrugated sheets should have a lap of 1 1/2 or 2 corrugations side-lap for roofing in order to secure water-tight side seams; if the roof is rather steep 1 1/2 corrugations will answer. Some manufacturers make a special high-edge corrugation on sides of sheets, and thereby are enabled to secure a water-proof side-lap with one corrugation only, thus saving from 6% to 12% of material to cover a given area.

No. 28 gage corrugated iron is generally used for applying to wooden buildings; but for applying to iron framework No. 24 gage or heavier should be adopted.

Galvanizing sheet iron adds about 2 1/2 oz. to its weight per square foot.

**Slate.**

Slate in roofs is measured by the square, 1 square being equal to 100 superficial square feet. In measuring, the width of the eaves is allowed at the widest part. Hips, valleys, and cuttings are measured lineally and 6 in. extra is allowed. The thickness of slate for roofing varies usually from 1/8 to 3/16 in. The weight varies, when lapped, from 4 1/2 to 6 3/4 lb. per sq. ft. The laps range from 2 to 4 in., 3 in. being the standard. As slate is usually laid, the number of square feet of roof covered by one slate is  $w(l - 3) \div 288$ ,  $w$  and  $l$  being the width and length respectively of the slate in inches.

**Number and Superficial Area of Slate for One Square of Roof.**

Size, In.	No. per Sq.	Area, Sq. Ft.	Size, In.	No. per Sq.	Area, Sq. Ft.	Size, In.	No. per Sq.	Area, Sq. Ft.	Size, In.	No. per Sq.	Area, Sq. Ft.
6 × 12	533	267	10 × 14	261	.....	10 × 20	169	235	12 × 24	114	228
7 × 12	457	.....	8 × 16	277	246	11 × 20	154	.....	14 × 24	98	.....
8 × 12	400	.....	9 × 16	246	.....	12 × 20	141	.....	16 × 24	86	.....
9 × 12	355	.....	10 × 16	221	.....	14 × 20	121	.....	14 × 26	89	225
7 × 14	374	254	9 × 18	213	240	16 × 20	137	.....	16 × 26	78	.....
8 × 14	327	.....	10 × 18	192	.....	12 × 22	126	231	.....	.....	.....
9 × 14	291	.....	12 × 18	160	240	14 × 22	108	.....	.....	.....	.....

**Weight of Slate, in Pounds, for One Square of Roof.**

(1 cu. ft. slate = 175 lb.)

Length of Slate, In.	Thickness of Slate, Inch.							
	1/8	3/16	1/4	3/8	1/2	5/8	3/4	1
12	483	724	967	1450	1936	2419	2902	3872
14	460	688	920	1379	1842	2301	2760	3683
16	445	667	890	1336	1784	2229	2670	3567
18	434	650	869	1303	1740	2174	2607	3480
20	425	637	851	1276	1704	2129	2553	3408
22	418	626	836	1254	1675	2093	2508	3350
24	412	617	825	1238	1653	2066	2478	3306
26	407	610	815	1222	1631	2039	2445	3263

**Corrugated Arches.**

For corrugated curved sheets for floor and ceiling construction in fireproof buildings, No. 16, 18, or 20 gage iron is commonly used, and sheets may be curved from 4 to 10 in. rise—the higher the rise the stronger the arch. By a series of tests it has been demonstrated that corrugated arches give the most satisfactory results with a base length not exceeding 6 ft., and 5 ft. or even less is preferable where great strength is required. These corrugated arches are made with 1 1/4 × 3/8,

2 1/2 x 1/2, 3 x 3/4, and 5 x 7/8 in. corrugations, and in the same width of sheet as above mentioned.

**Terra-Cotta.**

*Porous terra-cotta* roofing 3 in. thick weighs 16 lb. per square foot and 2 in. thick 12 lb. per square foot.

*Ceiling* made of the same material 2 in. thick weighs 11 lb. per square foot.

**Tiles.**

*Flat tiles* 6 1/4 x 10 1/2 x 5/8 in. weigh from 1480 to 1850 lb. per square of roof (100 square feet), the lap being one-half the length of the tile.

*Tiles with grooves and fillets* weigh from 740 to 925 lb. per square of roof.

*Pan-tiles* 14 1/2 x 10 1/2 laid 10 in. to the weather weigh 850 lb. per square.

**Pine Shingles.**

The figures below give the weight of shingles required to cover one square of a common gable roof. For hip roofs add 5 per cent.

Inches exposed to weather.....	4	4 1/2	5	5 1/2	6
No. of shingles per square of roof.....	900	800	720	655	600
Weight of shingles per square, lb.....	216	192	173	157	144

**Skylight Glass Required for One Square of Roof.**

Dimensions, in.....	12 x 48	15 x 60	20 x 100	94 x 156
Thickness, in.....	3/16	1/4	3/8	1/2
Area, sq. ft.....	3.997	6.246	13.880	101.768
Weight per square, lb.....	250	350	500	700

No allowance has been made in the above figures for lap. If ordinary window-glass is used, single thick glass (about 1/16 inch) will weigh about 82 lb. per square, and double thick glass (about 1/8 inch) will weigh about 164 lb. per square, *no allowance being made for lap*. A box of ordinary window-glass contains as nearly 50 square feet as the size of the panes will admit. Panes of any size are made to order by the manufacturers, but a great variety of sizes are usually kept in stock, ranging from 6 x 8 inches to 36 x 60 inches.

**THICKNESS OF CAST-IRON WATER-PIPES.**

P. H. Baermann, in a paper read before the Engineers' Club of Philadelphia in 1882, gave twenty different formulæ for determining the thickness of cast-iron pipes under pressure. The formulæ are of three classes:

1. Depending upon the diameter only.
  2. Those depending upon the diameter and head and which add a constant.
  3. Those depending upon the diameter and head contain an additive or subtractive term depending upon the diameter, and add a constant.
- The more modern formulæ are of the third class, and are as follows:

$t = 0.00008hd + 0.01d + 0.36$ .....	Shedd,	No. 1.
$t = 0.00006hd + 0.0133d + 0.296$ .....	Warren Foundry,	No. 2.
$t = 0.000058hd + 0.0152d + 0.312$ .....	Francis,	No. 3.
$t = 0.090048hd + 0.013d + 0.32$ .....	Dupuit,	No. 4.
$t = 0.00004hd + 0.1 \sqrt{d} + 0.15$ .....	Box,	No. 5.
$t = 0.000135hd + 0.4 - 0.0011d$ .....	Whitman,	No. 6.
$t = 0.00006(h + 230)d + 0.333 - 0.0033d$ .....	Fanning,	No. 7.
$t = 0.00015hd + 0.25 - 0.0052d$ .....	Meggs,	No. 8.

In which  $t$  = thickness in inches,  $h$  = head in feet,  $d$  = diameter in inches. For  $h = 100$  ft., and  $d = 10$  in., formulæ Nos. 1 to 7 inclusive give to from 0.49 to 0.54 in., but No. 8 gives only 0.35 in. Fanning's formula, now (1908) in most common use, gives 0.50 in.

Rankine (*Civil Engineering*), p. 721, says: "Cast-iron pipes should be made of a soft and tough quality of iron. Great attention should be paid

to molding them correctly, so that the thickness may be exactly uniform all round. Each pipe should be tested for air-bubbles and flaws by ringing it with a hammer, and for strength by exposing it to double the intended greatest working pressure." The rule for computing the thickness of a pipe to resist a given working pressure is  $t = rp/f$ , where  $r$  is the radius in inches,  $p$  the pressure in pounds per square inch, and  $f$  the tensile strength of the iron per square inch. When  $f = 18,000$ , and a factor of safety of 5 is used, the above expressed in terms of  $d$  and  $h$  becomes  $t = 0.5d \times 0.433h \div 3600 = 0.00006dh$ .

"There are limitations, however, arising from difficulties in casting, and by the strain produced by shocks, which cause the thickness to be made greater than that given by the above formula." (See also Bursting Strength of Cast-Iron Cylinders, under "Cast Iron.")

The most common defect of cast-iron pipes is due to the "shifting of the core," which causes one side of the pipe to be thinner than the other. Unless the pipe is made of very soft iron the thin side is apt to be chilled in casting, causing it to become brittle and it may contain blow-holes and "cold-shots." This defect should be guarded against by inspection of every pipe for uniformity of thickness.

**Standard Thicknesses and Weights of Cast-Iron Pipe.**

(U. S. Cast Iron Pipe & Foundry Co., 1915.)

Nominal Inside Diam. Ins.	Class A. 100 Ft. Head. 43 Lb. Pressure.			Class B. 200 Ft. Head. 86 Lb. Pressure.			Class C. 300 Ft. Head. 130 Lb. Pressure.			Class D. 400 Ft. Head. 173 Lb. Pressure.		
	Thick-ness, In.	Pounds per		Thick-ness, In.	Pounds per		Thick-ness, In.	Pounds per		Thick-ness, In.	Pounds per	
		Ft.	L'gth.		Ft.	L'gth.		Ft.	L'gth.		Ft.	L'gth.
3	0.39	14.5	175	0.42	16.2	194	0.45	17.1	205	0.48	18.0	216
4	.42	20.0	240	.45	21.7	260	.48	23.3	280	.52	25.0	300
6	.44	30.8	370	.48	33.3	400	.51	35.8	430	.55	38.3	460
8	.46	42.9	515	.51	47.5	570	.56	52.1	625	.60	55.8	670
10	.50	57.1	685	.57	63.8	765	.62	70.8	850	.68	76.7	920
12	.54	72.5	870	.62	82.1	985	.68	91.7	1100	.75	100.0	1200
14	.57	89.6	1075	.66	102.5	1230	.74	116.7	1400	.82	129.2	1550
16	.60	108.3	1300	.70	125.0	1500	.80	143.8	1725	.89	158.3	1900
18	.64	129.2	1550	.75	150.0	1800	.87	175.0	2100	.96	191.7	2300
20	.67	150.0	1800	.80	175.0	2100	.92	208.3	2500	1.03	229.2	2750
24	.76	204.2	2450	.89	233.3	2800	1.04	279.2	3350	1.16	306.7	3680
30	.88	291.7	3500	1.03	333.3	4000	1.20	400.0	4800	1.37	450.0	5400
36	.99	391.7	4700	1.15	454.2	5450	1.36	545.8	6550	1.58	625.0	7500
42	1.10	512.5	6150	1.28	591.7	7100	1.54	716.7	8600	1.78	825.0	9900
48	1.26	666.7	8000	1.42	750.0	9000	1.71	908.3	10900	1.96	1050.0	12600
54	1.35	800.0	9600	1.55	933.3	11200	1.90	1141.7	13700	2.23	1341.7	16100
60	1.39	916.7	11000	1.67	1104.2	13250	2.00	1341.7	16100	2.38	1583.3	19000
72	1.62	1281.9	15380	1.95	1547.3	18570	2.39	1904.3	22850	..	....	....
84	1.72	1635.8	19630	2.22	2104.1	25250	...	.....	.....	..	....	....

The above weights are per length to lay 12 feet, including standard sockets; proportionate allowance to be made for any variation.

**Weight of Underground Pipes.** (Adopted by the Natl. Fire Protection Association, 1913.) Weights are not to be less than those specified when the normal pressures do not exceed 125 lb. per sq. in. When the normal pressures are in excess of 125 lb. heavier pipes should be used. The weights given include sockets.

Pipe, in. ....	4	6	8	10	12	14	16
Weights per foot, lb....	23	35.8	52.1	70.8	91.7	116.7	143.8

## Standard Thicknesses and Weights of Cast Iron Pipe.

## For Fire Lines and High-Pressure Service.

(U. S. Cast Iron Pipe &amp; Foundry Co., 1915.)

Nominal Inside Diam., In.	Class E. 500 ft. Head. 217-lb. Pressure.			Class F. 600 ft. Head. 260-lb. Pressure.			Class G. 700 ft. Head. 304-lb. Pressure.			Class H. 800 ft. Head. 347-lb. Pressure.		
	Thick- ness, In.	Lb. per		Thick- ness, In.	Lb. per		Thick- ness, In.	Lb. per		Thick- ness, In.	Lb. per	
		Ft.	Lgth.		Ft.	Lgth.		Ft.	Lgth.		Ft.	Lgth.
6	0.58	42.5	510	0.61	44.3	531	0.65	48.1	577	0.69	50.5	606
8	.66	60.9	731	.71	66.8	802	.75	72.3	868	.80	76.1	913
10	.74	86.9	1043	.80	92.8	1114	.86	101.4	1217	.92	107.3	1288
12	.82	114.6	1375	.89	122.8	1474	.97	136.2	1634	1.04	144.4	1733
14	.90	145.6	1747	.99	158.8	1905	1.07	175.1	2101	1.16	187.5	2250
16	.98	180.7	2168	1.08	196.5	2358	1.18	218.0	2616	1.27	233.8	2805
18	1.07	221.8	2662	1.17	239.3	2872	1.28	268.2	3218	1.39	287.8	3453
20	1.15	265.8	3190	1.27	287.3	3448	1.39	321.8	3862	1.51	345.8	4149
24	1.31	359.1	4309	1.45	392.3	4707	1.75	479.8	5758	1.88	510.6	6127
30	1.55	530.9	6371	1.73	588.8	7065	.....	.....	.....	.....	.....	.....
36	1.80	738.1	8857	2.02	821.0	9852	.....	.....	.....	.....	.....	.....

All lengths to lay 12 ft. Weights are approximate; those per foot include allowance for bell; those per length include bell. Proportionate allowance is to be made for variations from standard length.

## Standard and Heavy Cast Iron Bell and Spigot Gas Pipe.

## Weights and Dimensions.

(U. S. Cast Iron Pipe &amp; Foundry Co., 1914.)

Nominal Dia., In.	Actual Out- side Dia., In.		Thickness, In.		Dia. of Sock- ets, In.		Depth of Sockets, In.	Weight per Foot, Lb.		Weight per Length, Lb.	
	Stand- ard.	Heavy.	Stand- ard.	Heavy.	Stand- ard.	Heavy.		Stand- ard.	Heavy.	Stand- ard.	Heavy.
4	4.80	5.00	0.40	0.42	5.80	5.80	4.00	19.33	20.0	232	240
6	6.90	7.10	.43	.47	7.90	7.90	4.00	30.25	32.8	363	394
8	9.05	9.05	.45	.49	10.05	9.85	4.00	42.08	45.3	505	544
10	11.10	11.10	.49	.51	12.10	11.90	4.00	55.91	58.7	671	703
12	13.20	13.20	.54	.57	14.20	14.00	4.50	73.83	76.1	886	913
16	17.40	17.40	.62	.65	18.40	18.40	4.50	112.58	117.2	1351	1406
20	21.60	21.60	.68	.75	22.85	22.60	4.50	153.83	166.7	1846	2000
24	25.80	25.80	.76	.82	27.05	26.80	5.00	206.41	224.0	2477	2683
30	31.74	32.00	.85	1.00	32.99	33.00	5.00	284.00	323.9	3408	3887
36	37.96	38.30	.95	1.05	39.21	39.30	5.00	379.25	442.7	4551	5312
42	44.20	44.50	1.07	1.26	45.45	45.50	5.00	497.66	581.3	5972	6975
48	50.50	50.80	1.26	1.38	51.75	51.80	5.00	663.50	739.6	7962	8875

The Standard pipe listed above conforms to the standard adopted by the American Gas Institute in 1911. The heavy pipe given is not included in the A. G. I. standards but is used by many gas engineers for service under paved streets with heavy traffic, or where subsoil conditions make the heavier pipe desirable. Pipes are made to lay 12 ft. length. Weights per foot include bell and bead. Length of bead = 0.75 in. for 4- and 6-in. pipe; 1.00 in. for 8- to 48-in. pipe. Thickness of bead = 0.19 in. for 4- and 6-in. pipe; 0.25-in. for 8- to 48-in. pipe.



**Standard Flanged Cast Iron Pipe for Gas.**

(United Cast Iron Pipe & Foundry Co., 1914, Am. Gas. Inst. Std., 1913.)

Nominal Diam., In.	Thick-ness, In.	Flange Diam., In.	Flange Thick-ness, In.	Bolt Circle Diam., In.	Bolts		Wgt. Single Flange, Lb.	Approx. Wgt., Lb.	
					No.	Size, In.		Foot.	Lgth.
4	0.40	9.00	0.72	7.125	4	0.625	8.19	18.62	223
6	.43	11.00	.72	9.125	4	.625	10.46	29.01	348
8	.45	13.00	.75	11.125	8	.625	12.65	40.05	481
10	.49	16.00	.86	13.75	8	.625	22.53	54.71	656
12	.54	18.00	.875	15.75	8	.625	25.96	71.34	856
16	.62	22.50	1.00	20.00	12	.75	39.68	108.61	1303
20	.68	27.00	1.00	24.50	16	.75	51.10	147.95	1775
24	.76	31.00	1.125	28.50	16	.75	65.00	197.38	2369
30	.85	37.50	1.25	35.00	20	.875	96.70	273.45	3281
36	.95	44.00	1.375	41.25	24	.875	132.26	366.67	4400
42	1.07	50.75	1.56	47.75	28	1.00	186.83	483.48	5802
48	1.26	57.00	1.75	54.00	32	1.00	235.23	647.36	7768

Pipe is made in 12-ft. lengths, and faced 1/16 in. short for gaskets. Weight per foot includes flanges. Flanges are Am. Gas. Inst., and are different from the "American 1914" standard for water and steam pipe. Pipes heavier than above may be made by reducing internal diameters.

**Threaded Cast Iron Pipe.**

(U. S. Cast Iron Pipe & Foundry Co., 1914.)

Nominal diam., in . . . . .	3	4	6	8	10	12
Actual outside diam., in . . . . .	3.96	5.00	7.10	9.30	11.40	13.50
Thickness, in., Class B . . . . .	0.42	0.45	0.48	0.51	0.57	0.62
Wt. per foot, Class B . . . . .	14.6	20.1	31.2	43.9	60.5	78.9
Thickness, in., Class D . . . . .	0.48	0.52	0.55	0.60	0.68	0.75
Wt. per foot, Class D . . . . .	16.4	22.8	35.3	51.2	71.4	93.7

**Quantity of Lead Required for Cast Iron Pipe Bell and Spigot Joints.**

(U. S. Cast Iron Pipe & Foundry Co., 1914.)

Diameter, In.	Depth of Joint				Diameter, In.	Depth of Joint			
	2 In.	2 1/4 In.	2 1/2 In.	Solid.		2 In.	2 1/4 In.	2 1/2 In.	Solid.
Approx. Weight of Lead in Joint.—Lb.					Approx. Weight of Lead in Joint.—Lb.				
3	6.00	6.50	7.00	10.25	24	44.00	48.00	52.50	95.00
4	7.50	8.00	8.75	13.00	30	54.25	59.50	64.75	117.50
6	10.25	11.25	12.25	18.00	36	64.75	71.00	77.25	140.25
8	13.25	14.50	15.75	23.00	42	75.25	78.75	85.50	155.25
10	16.00	17.50	19.00	31.00	48	85.50	94.00	102.25	202.25
12	19.00	20.50	22.50	36.50	54	97.60	107.10	116.60	238.60
14	22.00	24.00	26.00	38.50	60	108.30	118.80	129.50	255.50
16	30.00	33.00	35.75	64.75	72	128.00	140.50	153.00	302.50
18	33.80	36.90	40.00	72.00	84	147.00	161.50	175.60	348.00
20	37.00	40.50	44.00	80.00					

The above table gives the calculated weight of lead required for pipe joints both with and without gasket. Weight of lead taken at 0.41 lb. per cu. in. Allowance has been made for lead to project beyond the face of the bell for calking. Pipe specifications allow lead space to vary from those given in tables, hence the weights of lead may vary approximately 11 to 16 per cent from those given above.

## Cast-Iron Pipe Columns, Weight and Safe Loads, Pounds.

(U. S. Cast Iron Pipe and Foundry Co., 1914.)

Length.	4-Inch Pipe.		6-Inch Pipe.		8-Inch Pipe.		10-Inch Pipe.	
	Wgt.	Load.	Wgt.	Load.	Wgt.	Load.	Wgt.	Load.
6 ft. 0 in.	160	56070	245	100100	359	164410	428	224200
6 6	171	54130	262	98310	385	162400	464	222300
7 0	183	52190	280	96270	410	160350	500	220300
7 6	194	50250	298	94100	436	158200	535	218300
8 0	206	48320	316	92040	462	156000	571	216200
8 6	217	46440	333	89820	487	153600	607	213900
9 0	229	44590	351	87620	513	151200	643	211600
9 6	240	42800	368	85450	539	148760	678	209300
10 0	251	41050	386	83260	564	146260	714	206900
10 6	262	39360	404	81040	590	143700	750	204500
11 0	274	37730	421	78840	615	141160	785	202200
11 6	285	36160	439	76700	642	138570	821	199800
12 0	297	34670	457	74580	667	135920	857	197400
12 6	308	33220	474	71600	692	133340	893	195000
Base and Top Castings.								
Ins. square	10		12		14		16	
Wt., lbs.	65		100		145		200	

Add weight of base and top castings for complete weight of column. Loads are based on Gordon's formula, with a factor of safety of 8.

## Weight of Open End Cast-Iron Cylinders.

Cast iron = 450 lbs. per cubic foot.

Pounds per Lineal Foot.

Bore.	Thick. of Metal.	Wgt. per Foot.	Bore.	Thick. of Metal.	Wgt. per Foot.	Bore.	Thick. of Metal.	Wgt. per Foot.	Bore.	Thick. of Metal.	Wgt. per Foot.
4	In. 3/8	16.1	11	In. 1/2	56.5	17	In. 7/8	153.6	24	In. 7/8	213.7
	1/2	22.1		5/8	71.3		5/8	114.3		1	245.4
	5/8	28.4		3/4	86.5		3/4	138.1		26	3/4
5	3/8	19.8	12	1/2	61.4	19	7/8	162.1	28	7/8	230.9
	1/2	27.0		5/8	77.5		5/8	120.4		1	265.1
	5/8	34.4		3/4	93.9		3/4	145.4		28	3/4
6	3/8	23.5	13	1/2	66.3	20	7/8	170.7	30	7/8	248.1
	1/2	31.9		5/8	83.6		5/8	126.6		1	284.7
	5/8	40.7		3/4	101.2		3/4	152.8		30	7/8
7	3/8	27.2	14	1/2	71.2	21	7/8	179.3	32	1	304.3
	1/2	36.8		5/8	89.7		5/8	132.7		11/8	343.7
	5/8	46.8		3/4	108.6		3/4	160.1		32	7/8
8	3/8	30.8	15	5/8	95.9	22	7/8	187.9	34	1	324.0
	1/2	41.7		3/4	116.0		5/8	138.8		11/8	365.8
	5/8	52.9		7/8	136.4		3/4	167.5		34	7/8
9	1/2	46.6	16	5/8	102.0	23	7/8	196.5	36	1	343.7
	5/8	59.1		3/4	123.3		3/4	174.9		11/8	388.0
	3/4	71.8		7/8	145.0		7/8	205.1		36	7/8
10	1/2	51.5	17	5/8	108.2	24	1	235.6	1	1	363.1
	5/8	65.2		3/4	130.7		3/4	182.2		11/8	410.0

The weight of two flanges may be reckoned = weight of one foot.

**WROUGHT-IRON (OR STEEL) WELDED PIPE.**

For discussion of the Briggs Standard of Wrought-iron Pipe Dimensions, see Report of the Committee of the A. S. M. E. in "Standard Pipe and Pipe Threads," 1886. Trans., Vol. VIII, p. 29. The diameter of the bottom of the thread is derived from the formula  $D - (0.05D + 1.9) \times \frac{1}{n}$ , in which  $D$  = outside diameter of the tubes, and  $n$  the number of threads to the inch. The diameter of the top of the thread is derived from the formula  $0.8 \frac{1}{n} \times 2 + d$ , or  $1.6 \frac{1}{n} + d$ , in which  $d$  is the diameter at the bottom of the thread at the end of the pipe. The sizes for the diameters at the bottom and top of the thread at the end of the pipe are as follows:

**Standard Pipe Threads.**

Size.	Nominal External Diam.	Threads per Inch.	Diam. of Pipe at Root of Thread.	Diam. of Pipe at Top of Thread.	Size.	Nominal External Diam.	Threads per Inch.	Diam. of Pipe at Root of Thread.	Diam. of Pipe at Top of Thread.
1/8	0.405	27	0.3339	0.3931	5	5.563	8	5.2907	5.4907
1/4	.540	18	.4329	.5218	6	6.625	8	6.3460	6.5460
3/8	.675	18	.5676	.6565	7	7.625	8	7.3398	7.5398
1/2	.840	14	.7013	.8156	8	8.625	8	8.3336	8.5336
3/4	1.050	14	.9105	1.0248	9	9.625	8	9.3273	9.5273
1	1.315	11 1/2	1.1440	1.2832	10	10.750	8	10.4453	10.6453
1 1/4	1.660	11 1/2	1.4876	1.6267	11	11.750	8	11.4390	11.6390
1 1/2	1.900	11 1/2	1.7265	1.8657	12	12.750	8	12.4328	12.6328
2	2.375	11 1/2	2.1995	2.3386	13	14.000	8	13.6750	13.8750
2 1/2	2.875	8	2.6195	2.8195	14	15.000	8	14.6688	14.8688
3	3.500	8	3.2406	3.4406	15	16.000	8	15.6625	15.8625
3 1/2	4.000	8	3.7375	3.9375	17 O.D.	17.000	8	16.6563	16.8563
4	4.500	8	4.2343	4.4343	18 O.D.	18.000	8	17.6500	17.8500
4 1/2	5.000	8	4.7313	4.9313	20 O.D.	20.000	8	19.6375	19.8375

**Tap Drills for Pipe Taps (Briggs' Standard).**

Size of Tap, In.	Size of Drill, In.	Size of Tap, In.	Size of Drill, In.	Size of Tap, In.	Size of Drill, In.	Size of Tap, In.	Size of Drill, In.
1/8	21/64	3/4	15/16	2	2 3/16	4	4 3/16
1/4	29/64	1	1 3/16	2 1/2	2 11/16	4 1/2	4 11/16
3/8	19/32	1 1/4	1 15/32	3	3 5/16	5	5 1/4
1/2	23/32	1 1/2	1 23/32	3 1/2	3 13/16	6	6 15/16

Having the taper, length of full-threaded portion, and the sizes at bottom and top of thread at the end of the pipe, as given in the table, taps and dies can be made to secure these points correctly, the length of the imperfect threaded portions on the pipe, and the length the tap is run into the fittings beyond the point at which the size is as given, or, in other words, beyond the end of the pipe, having no effect upon the standard. The angle of the thread is 60°, and it is slightly rounded off at top and bottom, so that, instead of its depth being 0.866 its pitch, as is the case with a full V-thread, it is 4/5 the pitch, or equal to  $0.8 \div n$ ,  $n$  being the number of threads per inch.

Taper of conical tube ends, 1 in 32 to axis of tube = 3/4 inch to the foot total taper.

The thread is perfect for a distance ( $L$ ) from the end of the pipe, expressed by the rule,  $L = (0.8 D + 4.8) \div n$ ; where  $D$  = outside diameter

Dimensions of Standard Welded Pipe. (National Tube Company, 1915.)

Size.	Diameter.		Thickness	Threads per Inch	Weight per Foot		Circumference		Transverse Area			Length of Pipe per Sq. Foot		Length to Contain One Cu. Ft.	U. S. Gals. in One Lin. Ft. of Pipe.	Water in One Lin. Ft. of Pipe.
	Exter. In.	Inter. In.			Plain Ends	Thrs and Coup.	Exter. In.	Inter. In.	Exter. Sq. In.	Inter. Sq. In.	Metal Sq. In.	Extr. Surface.	Int. Surface.			
1/8	0.405	0.269	0.068	27	0.244	0.245	1.272	0.845	0.129	0.057	0.072	9.431	14.199	2533.775	0.003	0.025
1/4	.540	.364	.088	18	.424	.425	1.696	1.144	.229	.104	.125	7.073	10.493	1383.789	0.005	.045
3/8	.675	.493	.091	18	.567	.568	2.121	1.549	.358	.191	.167	5.658	7.747	754.360	0.010	.083
1/2	.840	.622	.109	14	.850	.852	2.639	1.954	.554	.304	.250	4.547	6.141	473.906	.016	.132
3/4	1.050	.824	.113	14	1.130	1.134	3.299	2.589	.866	.533	.333	3.637	4.635	270.034	.028	.231
1	1.315	1.049	.133	11 1/2	1.678	1.684	4.131	3.296	1.358	.864	.494	2.904	3.641	166.618	.045	.375
1 1/4	1.660	1.380	.140	11 1/2	2.272	2.281	5.215	4.335	2.164	1.495	.669	2.301	2.767	96.275	.078	.648
1 1/2	1.900	1.610	.145	11 1/2	2.717	2.731	5.969	5.058	2.835	2.036	.799	2.010	2.372	70.733	.106	.883
2	2.375	2.067	.154	11 1/2	3.652	3.678	7.461	6.494	4.430	3.355	1.075	1.608	1.847	42.913	.174	1.455
2 1/2	2.875	2.469	.203	8	5.793	5.819	9.032	7.757	6.492	4.788	1.704	1.328	1.547	30.077	.249	2.076
3	3.500	3.068	.216	8	7.575	7.616	10.996	9.638	9.621	7.393	2.228	1.091	1.245	19.479	.384	3.205
3 1/2	4.000	3.548	.226	8	9.109	9.202	12.566	11.146	12.566	9.886	2.680	0.954	1.076	14.565	.514	4.286
4	4.500	4.026	.237	8	10.790	10.889	14.137	12.648	15.904	12.730	3.174	.848	0.948	11.312	.661	5.919
4 1/2	5.000	4.506	.247	8	12.538	12.642	15.708	14.156	19.635	15.947	3.688	.763	0.847	9.030	.828	8.673
5	5.563	5.047	.258	8	14.617	14.810	17.477	15.856	24.306	20.006	4.300	.686	0.756	7.198	1.039	11.521
6	6.625	6.065	.280	8	18.974	19.185	20.813	19.054	34.472	28.891	5.581	.576	.629	4.984	1.501	16.524
7	7.625	7.023	.301	8	23.544	23.769	23.955	22.063	45.664	38.738	6.926	.500	.543	3.717	2.012	22.793
8	8.625	8.071	.322	8	24.696	25.000	27.096	25.356	58.426	51.161	7.265	.442	.473	2.815	2.638	32.179
8	8.625	8.071	.322	8	28.594	28.809	30.238	28.089	58.426	50.027	8.399	.442	.478	2.878	2.599	21.687
9	9.625	8.941	.342	8	33.907	34.188	37.096	35.073	72.760	62.786	9.974	.396	.427	2.294	3.262	27.218
10	10.750	10.192	.279	8	31.201	32.000	33.772	32.019	90.763	81.585	9.178	.355	.374	1.765	4.238	35.366
10	10.750	10.136	.307	8	34.240	35.000	33.772	31.843	90.763	80.691	10.072	.355	.376	1.785	4.192	34.980
10	10.750	10.020	.365	8	40.483	41.132	33.772	31.479	108.434	95.033	13.400	.325	.347	1.826	4.096	34.184
11	11.750	11.000	.375	8	45.557	46.247	36.914	34.558	108.434	95.033	13.400	.299	.315	1.515	4.937	41.196
12	12.750	12.090	.330	8	43.773	45.000	40.055	37.982	127.676	114.800	12.876	.288	.318	1.273	5.964	49.767
12	12.750	12.000	.375	8	49.562	50.706	40.055	37.699	153.938	137.886	16.052	.272	.288	1.044	7.163	59.775
13	14.000	13.250	.375	8	54.568	55.824	43.982	41.626	173.938	159.485	17.230	.254	.268	0.903	8.285	69.138
14	15.000	14.250	.375	8	58.573	60.375	47.124	44.768	176.715	159.485	17.230	.238	.250	0.788	9.489	79.182
15	16.000	15.250	.375	8	62.579	64.500	50.265	47.909	201.062	182.654	18.408	.222	.235	0.697	10.726	89.509
17 O. D.	17.000	16.214	.393	8	69.704	72.602	53.407	50.938	226.980	206.476	20.504	.212	.222	.621	12.045	100.516
18 O. D.	18.000	17.182	.409	8	76.840	80.482	56.549	53.979	254.469	231.866	22.603	.190	.222	.621	12.045	100.516
20 O. D.	20.000	19.182	.409	8	85.577	89.617	62.832	60.262	314.159	288.986	25.173	.190	.199	.498	15.012	125.278



in inches. Then come two threads, perfect at the root or bottom, but imperfect at the top, and then come three or four threads imperfect at both top and bottom. These last do not enter into the joint at all, but are incident to the process of cutting the threads. The thickness of the pipe under the root of the thread at the end of the pipe =  $0.0175 D + 0.025$  in.

Briggs' standard gages are made by Pratt & Whitney Co., Hartford, Conn.

**Standard Welded Pipe.**—The permissible variation in weights is 5% above and 5% below those given in the table on the opposite page. Pipe is furnished with threads and couplings, and in random lengths unless otherwise ordered. Weights are figured on the basis of one cubic inch of steel weighing 0.2833 lb., and the weight per foot with threads and couplings is based on a length of 20 feet, including the coupling, but shipping lengths of small sizes will usually average less than 20 feet. Taper of threads is  $\frac{3}{4}$  inch diameter per foot length for all sizes. The weight of water contained in one lineal foot is based on a weight of 62.425 pounds per cubic foot, which is the weight at its maximum density (39.1° F.)

The steel used for lap-welded pipe has the following average analysis and physical properties:

	C	Mn	S	P	El. Lim.	Tens. Str.	Elong. in 8 in.
Bessemer.....	0.07	0.30	0.045	0.100	36,000	58,000	22%
Open-hearth.....	0.09	0.40	0.035	0.025	33,000	53,000	25%

**Extra Strong Pipe.** (National Tube Company, 1915)

Size.	Diameter.		Thickness.	Wt. per Ft., Plain Ends.		Circumference.		Transverse Area.			Length of Pipe per Sq. Foot.		Length of Pipe Containing One Cu. Ft.
	Exter-nal.	Inter-nal.		In.	Lb.	Exter-nal.	Inter-nal.	Exter-nal.	Inter-nal.	Metal.	Ext. Surface	Int. Surface	
$\frac{1}{8}$	0.405	0.215	.095	0.314	1.272	0.675	0.129	0.036	0.093	9.431	17.766	3966.393	
$\frac{1}{4}$	.540	.302	.119	.535	1.696	.949	.229	.072	.157	7.073	12.648	2010.290	
$\frac{3}{8}$	.675	.423	.126	.738	2.121	1.329	.358	.141	.217	5.658	9.030	1024.689	
$\frac{1}{2}$	.840	.546	.147	1.087	2.639	1.715	.554	.234	.320	4.547	6.995	615.017	
$\frac{3}{4}$	1.050	.742	.154	1.473	3.299	2.331	.866	.433	.433	3.637	5.147	333.016	
1	1.315	.957	.179	2.171	4.131	3.007	1.358	.719	.639	2.904	3.991	200.193	
$1\frac{1}{4}$	1.660	1.278	.191	2.996	5.215	4.015	2.164	1.283	.881	2.301	2.988	112.256	
$1\frac{1}{2}$	1.900	1.500	.200	3.631	5.969	4.712	2.835	1.767	1.068	2.010	2.546	81.487	
2	2.375	1.939	.218	5.022	7.461	6.092	4.430	2.953	1.477	1.608	1.969	48.766	
$2\frac{1}{2}$	2.875	2.323	.276	7.661	9.032	7.298	6.492	4.238	2.254	1.328	1.644	33.976	
3	3.500	2.900	.300	10.252	10.996	9.111	9.621	6.605	3.016	1.091	1.317	21.801	
$3\frac{1}{2}$	4.000	3.364	.318	12.505	12.566	10.568	12.566	8.888	3.678	0.954	1.135	16.202	
4	4.500	3.826	.337	14.983	14.137	12.020	15.904	11.497	4.407	.848	0.998	12.525	
$4\frac{1}{2}$	5.000	4.290	.355	17.611	15.708	13.477	19.635	14.455	5.180	.763	.890	9.962	
5	5.563	4.813	.375	20.778	17.477	15.120	24.306	18.194	6.112	.686	.793	7.915	
6	6.625	5.761	.432	23.573	20.813	18.099	34.472	26.067	8.405	.576	.663	5.524	
7	7.625	6.625	.500	33.048	23.955	20.813	45.664	34.472	11.192	.500	.576	4.177	
8	8.625	7.625	.500	43.388	27.096	23.955	58.426	45.663	12.763	.442	.500	3.154	
9	9.625	8.625	.500	43.728	30.238	27.096	72.760	58.426	14.334	.396	.442	2.465	
10	10.750	9.750	.500	54.735	33.772	30.631	90.763	74.662	16.101	.355	.391	1.929	
11	11.750	10.750	.500	60.075	36.914	33.772	108.434	90.763	17.671	.325	.355	1.587	
12	12.750	11.750	.500	65.415	40.055	36.914	127.676	108.434	19.242	.299	.325	1.328	
13	14.000	13.000	.500	72.091	43.982	40.841	153.938	132.732	21.206	.272	.293	1.085	
14	15.000	14.000	.500	77.431	47.124	43.982	176.715	153.938	22.777	.254	.272	0.935	
15	16.000	15.000	.500	82.771	50.265	47.124	201.062	176.715	24.347	.238	.254	.815	

The permissible variation in weight is 5% above and 5% below.

Furnished with plain ends and in random lengths unless otherwise ordered.

**Double Extra Strong Pipe.** (National Tube Company, 1915.)

Size.	Diameter.		Thickness.	Wt. per Ft., Plain Ends.	Circum- ference.		Transverse Area.			Length of Pipe per Sq. Foot.		Length of Pipe Containing One Cu. Ft.
	Exter- nal.	Inter- nal.			Exter- nal.	Inter- nal.	Exter- nal.	Inter- nal.	Metal.	Ext. Surface.	Int. Surface.	
1/2	0.840	0.252	0.294	1.714	2.639	0.792	0.554	0.050	0.504	4.547	15.157	2887.165
3/4	1.050	.434	.308	2.440	3.299	1.363	.866	.148	.718	3.637	8.801	973.404
1	1.315	.599	.358	3.659	4.131	1.882	1.358	.282	1.076	2.904	6.376	510.998
1 1/4	1.660	.896	.382	5.214	5.215	2.815	2.164	.630	1.534	2.301	4.263	228.379
1 1/2	1.900	1.100	.400	6.408	5.969	3.456	2.835	.950	1.885	2.010	3.472	151.526
2	2.375	1.503	.436	9.029	7.461	4.722	4.430	1.774	2.656	1.608	2.541	81.162
2 1/2	2.875	1.771	.552	13.695	9.032	5.564	6.492	2.464	4.028	1.328	2.156	58.457
3	3.500	2.300	.600	18.583	10.996	7.226	9.621	4.155	5.466	1.091	1.660	34.659
3 1/2	4.000	2.728	.636	22.850	12.566	8.570	12.566	5.845	6.721	0.954	1.400	24.637
4	4.500	3.152	.674	27.541	14.137	9.902	15.904	7.803	8.101	.848	1.211	18.454
4 1/2	5.000	3.580	.710	32.530	15.708	11.247	19.635	10.066	9.569	.763	1.066	14.306
5	5.563	4.063	.750	38.552	17.477	12.764	24.306	12.966	11.340	.686	0.940	11.107
6	6.625	4.897	.864	53.160	20.813	15.384	34.472	18.835	15.637	.576	.780	7.646
7	7.625	5.875	.875	63.079	23.955	18.457	45.664	27.109	18.555	.500	.650	5.312
8	8.625	6.875	.875	72.424	27.096	21.598	58.426	37.122	21.304	.442	.555	3.879

The permissible variation in weight is 10% above and 10% below.  
Furnished with plain ends and in random lengths unless otherwise ordered.

**Standard Boiler Tubes and Flues—Lap-Welded.**

(National Tube Company, 1915.)

Diameter.		Thickness.	Weight per Foot.	Circum- ference.		Transverse Area.			Length of Tube per Sq. Foot.			Length of Tube Containing One Cu. Ft.
Exter- nal.	Inter- nal.			Exter- nal.	Inter- nal.	Exter- nal.	Inter- nal.	Metal.	Ext. Surface.	Int. Surface.	Mean Surface.	
1 3/4	1.560	0.095	1.679	5.498	4.901	2.405	1.911	.494	2.182	2.448	2.315	75.340
2	1.810	.095	1.932	6.283	5.686	3.142	2.573	.569	1.909	2.110	2.010	55.965
2 1/4	2.060	.095	2.186	7.069	6.472	3.976	3.333	.643	1.697	1.854	1.775	43.205
2 1/2	2.282	.109	2.783	7.854	7.169	4.909	4.090	.819	1.527	1.673	1.600	35.208
2 3/4	2.532	.109	3.074	8.639	7.955	5.940	5.036	.904	1.388	1.508	1.448	28.599
3	2.782	.109	3.365	9.425	8.740	7.069	6.079	.990	1.273	1.373	1.323	23.690
3 1/4	3.010	.120	4.011	10.210	9.456	8.296	7.116	1.180	1.175	1.269	1.222	20.237
3 1/2	3.260	.120	4.331	10.996	10.242	9.621	8.347	1.274	1.091	1.171	1.131	17.252
3 3/4	3.510	.120	4.652	11.781	11.027	11.045	9.677	1.368	1.018	1.088	1.053	14.882
4	3.732	.134	5.532	12.566	11.724	12.566	10.939	1.627	0.954	1.023	0.989	13.164
4 1/2	4.232	.134	6.248	14.137	13.295	15.904	14.066	1.838	.848	0.902	.875	10.237
5	4.704	.148	7.669	15.708	14.778	19.635	17.379	2.256	.763	.812	.787	8.286
6	5.670	.165	10.282	18.850	17.813	28.274	25.249	3.025	.636	.673	.655	5.703
7	6.670	.165	12.044	21.991	20.954	38.485	34.942	3.543	.545	.572	.559	4.121
8	7.670	.165	13.807	25.133	24.096	50.265	46.204	4.061	.477	.498	.487	3.117
9	8.640	.180	16.955	28.274	27.143	63.617	58.629	4.988	.424	.442	.433	2.456
10	9.594	.203	21.240	31.416	30.140	78.540	72.292	6.248	.381	.398	.390	1.992
11	10.560	.220	25.329	34.558	33.175	95.033	87.582	7.451	.347	.361	.354	1.644
12	11.542	.229	28.788	37.699	36.260	113.097	104.629	8.468	.318	.330	.324	1.376
13	12.524	.238	32.439	40.841	39.345	132.732	123.190	9.542	.293	.304	.299	1.169
14	13.504	.248	36.424	43.982	42.424	153.938	143.224	10.714	.272	.282	.277	1.005
15	14.482	.259	40.775	47.124	45.497	176.715	164.721	11.994	.254	.263	.259	0.874
16	15.460	.270	45.359	50.265	48.569	201.062	187.719	13.343	.238	.247	.242	.767

## Weights and Bursting Strength of Lap-Welded Steel Pipe.

(American Spiral Pipe Works, Chicago, 1911.)

20-Ft. Lengths, Plain Ends without Connections. Thicknesses in U. S. Standard Gage or Inches. Bursting Strength in Lb. per Sq. In. Internal Pressure.

Inside Dia., Ins.	Thickness, Ins.	Wt. per Foot, Lb.	Bursting Strength.	Inside Dia., Ins.	Thickness, Ins.	Wt. per Foot, Lb.	Bursting Strength.	Inside Dia., Ins.	Thickness, Ins.	Wt. per Foot, Lb.	Bursting Strength.
12	10 G	19.3	1172	28	3/4	244	2678	42	1/4	119	595
"	3/16	25.8	1562	"	1	329	3570	"	1/2	239	1190
"	1/4	34.6	2083	"	1 1/4	416	4462	"	3/4	362	1784
14	10 G	22.4	1005	30	3/16	64	625	"	1	486	2380
"	1/4	40.2	1785	"	1/4	85	833	"	1 1/4	612	2976
"	3/8	61.0	2678	"	1/2	172	1666	44	1/4	124	568
"	1/2	82.0	3568	"	3/4	261	2500	"	1/2	250	1136
16	10 G	25.6	879	"	1	352	3328	"	3/4	378	1705
"	1/4	45.8	1562	"	1 1/4	444	4160	"	1	508	2277
"	3/8	69.4	2344	32	3/16	68	586	"	1 1/4	640	2840
"	1/2	93.5	3124	"	1/4	91	781	48	1/4	135	520
"	5/8	118.0	3904	"	1/2	183	1562	"	1/2	273	1040
18	10 G	28.7	781	"	3/4	278	2344	"	3/4	412	1562
"	1/4	51.4	1388	"	1	374	3125	"	1	553	2080
"	3/8	77.8	2082	"	1 1/4	472	3906	"	1 1/4	696	2604
"	1/2	104.7	2776	34	3/16	72	551	50	1/4	141	500
"	5/8	132.0	3472	"	1/4	96	735	"	1/2	284	1000
20	10 G	31.9	703	"	1/2	194	1470	"	3/4	429	1500
"	1/4	57.0	1250	"	3/4	294	2206	"	1	576	2000
"	1/2	116.2	2500	"	1	396	2942	"	1 1/4	724	2500
"	3/4	177.0	3736	"	1 1/4	500	3678	54	1/4	152	463
22	10 G	35.0	639	36	3/16	76	520	"	1/2	306	926
"	1/4	62.6	1136	"	1/4	102	694	"	3/4	462	1390
"	1/2	127.0	2272	"	1/2	206	1388	"	1	620	1852
"	3/4	194.0	3410	"	3/4	311	2080	"	1 1/4	780	2315
"	1	262.0	4555	"	1	419	2776	60	1/4	169	416
24	10 G	38.0	586	"	1 1/4	528	3472	"	1/2	340	832
"	1/4	68.0	1041	38	3/16	80	493	"	3/4	513	1250
"	1/2	138.0	2082	"	1/4	107	658	"	1	688	1664
"	3/4	210.0	3124	"	1/2	217	1316	"	1 1/4	864	2080
"	1	284.0	4160	"	3/4	328	1972	66	1/4	186	379
26	3/16	55.0	721	"	1	441	2632	"	1/2	374	758
"	1/4	74.0	961	"	1 1/4	556	3288	"	3/4	563	1132
"	1/2	150.0	1922	40	3/16	84	467	"	1	755	1516
"	3/4	227.0	2885	"	1/4	113	625	"	1 1/4	948	1892
"	1	307.0	3847	"	1/2	228	1250	72	1/4	203	347
"	1 1/4	388.0	4809	"	3/4	345	1868	"	1/2	407	694
28	3/16	60.0	669	"	1	464	2500	"	3/4	614	1040
"	1/4	80.0	892	"	1 1/4	584	3124	"	1	822	1388
"	1/2	161.0	1784	42	3/16	89	446	"	1 1/4	1032	1736

For dimensions of extra heavy rolled steel flanges for above pipe, see table page 211.

**Square Pipe**, external size, 7/8, 1, 1 1/4, 1 1/2, 1 11/16, 2, 2 1/2, 3 in.

**Rectangular Pipe**, external size, 1 1/4 × 1, 1 1/2 × 1 1/4, 2 × 1 1/4, 2 × 1 1/2, 2 1/2 × 1 1/2, 3 × 2.

Two or more thicknesses of each size.

**Pipe Specialties.**—Hand railings and their fittings; ladders with flat or round pipe bars and runners; seamless cylinders, with flat, domed, disked, or necked ends; special shapes for automobiles, to replace drop forgings; tapered tubes, and other specialties are illustrated in National Tube Co.'s Book of Standards.



## Special Sizes of Lap-welded Pipe—Boston Casing. (National Tube Co.)

Nom. Size.	Exter. Diam.	Thick-ness.	Nom. Size.	Exter. Diam.	Thick-ness.	Nom. Size.	Exter. Diam.	Thick-ness.	Nom. Size.	Exter. Diam.	Thick-ness.
2	2 1/4	0.100	4 1/2	4 3/4	0.145	5 5/8	6	0.224	8 1/4	8 5/8	0.217
2 1/4	2 1/2	.108	4 1/2	4 3/4	.193	5 5/8	6	.275	8 1/4	8 5/8	.264
2 1/2	2 3/4	.113	4 3/4	5	.152	6 1/4	6 5/8	.169	8 5/8	9	.196
2 3/4	3	.116	5	5 1/4	.153	6 1/4	6 5/8	.185	9 5/8	10	.209
3	3 1/4	.120	5	5 1/4	.182	6 5/8	7	.174	10 5/8	11	.224
3 1/4	3 1/2	.125	5	5 1/4	.182	6 5/8	7	.231	11 5/8	12	.243
3 1/2	3 3/4	.129	5	5 1/4	.241	7 1/4	7 5/8	.181	12 1/2	13	.259
3 3/4	4	.134	5	5 1/4	.301	7 5/8	8	.186	13 1/2	14	.276
4	4 1/4	.138	5 3/16	5 1/2	.154	7 5/8	8	.236	14 1/2	15	.291
4 1/4	4 1/2	.142	5 5/8	6	.164	8 1/4	8 5/8	.188	15 1/2	16	.302
4 1/4	4 1/2	.205	5 5/8	6	.190						

Other sizes of lap-welded pipe: Inserted Joint Casing, external diameters same as Boston Casing, with the least thickness. The 5 5/8 casing is made 0.164 and 0.190 in. thick. California Diamond X Casing, sizes 5 5/8 to 15 1/2, all heavier than Boston. Oil Well Tubing, 1 1/4 to 4 in.; Bedstead Tubing, 3/8 to 3 in.; Flush Joint Tubing, 3 to 18 in.; Allison Vanishing Thread Tubing, 2 to 8 in., ends upset, 1 1/4 to 8 in., ends not upset; Special Rotary Pipe, 2 1/2 to 6 in.; South Penn Casing, 5 3/16 to 12 1/2 in.; Reamed and Drifted Pipe, 2 to 6 in.; Air-line Pipe, 1 1/2 to 6 in.; Drill Pipe, 4 to 6 in.; Dry-kiln Pipe, 1 and 1 1/4 in.; Tuyere Pipe, 1 and 1 1/4 in.

## TUBULAR ELECTRIC LINE POLES.

For railway work the poles most used are 30 ft. long, and are composed of 7-in., 6-in., and 5-in. pipe. Anchor poles are usually 8-in., 7-in., and 6-in., but often they are made of larger pipe. Full directions for designing such poles are given in the National Tube Co.'s Book of Standards, which contains 38 pages of tables of dimensions, load, deflection, etc., of poles of different sizes and weights.

## PROTECTIVE COATINGS FOR PIPE.

(1) *Galvanizing*—The pipe cleaned from scale and rust by pickling in warm dilute sulphuric acid, washed, immersed in an alkaline bath, dried and immersed in molten zinc. (2) *Bituminous Coating*—The cleaned, dried and warmed pipe is dipped in a bath of refined coal tar pitch, free from water and the lighter oils, at a temperature not below 212°, and then baked. (3) *"National Coating."*—The bituminous coated pipe, after baking is wrapped with a strip of fabric saturated with the hot compound, the edges of the fabric overlapping.

## VALVES AND FITTINGS.

(From Information Furnished by National Tube Co., 1915.)

Wrought pipe is usually connected in one of three ways, screwed, flanged or leaded joints.

*Screwed.*—Pipe in sizes from 1/8 in. to 15 in. inclusive is regularly threaded on the ends, and is connected by means of threaded couplings.

*Flanged.*—Pipe in sizes 1 1/4 inches and larger is frequently connected by drilled flanges bolted together, the joint being made by a gasket between the flange faces.

Flanges are attached to the pipe in a variety of ways. The most common method for sizes of pipe from 1 1/4 in. to 15 in. inclusive is by screwing them on the pipe. Many prefer peened flanges for pipe larger than 6 in. The peened flange is shrunk on the end of the pipe, and the latter is then peened over or expanded into a recess in the flange face. Steel flanges are also welded to pipe and loose flanges are used by flanging over the pipe ends. When no method of attaching is stated, screwed flanges are always furnished.



*Working Pressures.*—All valves and fittings are classified, as a rule, under five general headings, representing the working pressures for which they are suitable, as follows: Low Pressure, up to 25 pounds per square inch. Standard, up to 125 pounds per square inch. Medium Pressure, from 125 pounds to 175 pounds per square inch. Extra Heavy, from 175 pounds to 250 pounds per square inch. Hydraulic, for high pressure water up to 800 pounds per square inch.

The following table gives the names of different valves and fittings, the material of which they are made, and the regular sizes manufactured for the different pressures (*L*, low; *S*, standard; *M*, medium; *E*, extra heavy; *H*, hydraulic):

SCREWED FITTINGS.

Malleable Iron.....	<i>S, E, H,</i>	sizes 1/8 to 8 in.
Cast Iron.....	<i>S, E,</i>	“ 1/4 to 12 in.

FLANGED FITTINGS.

Cast Iron.....	<i>L, S, E, H,</i>	sizes 2 in. and larger.
----------------	--------------------	-------------------------

GATE VALVES.

Brass.....	<i>L</i>	<i>S</i>	<i>M</i>	<i>E</i>	<i>H</i> up to 3 in.
Iron Body, sizes..	12 to 48	2 to 30	2 to 18	1 1/4 to 24	1 1/2 to 12 in.

GLOBE AND ANGLE VALVES.

Brass.....	<i>S,</i> 1/8 to 4; <i>M,</i> 1/4 to 3; <i>E,</i> 1/2 to 3; <i>H,</i> 1/2 to 2
Iron Body.....	<i>S,</i> 2 to 12; <i>E,</i> 2 to 12

CHECK VALVES.

Brass.....	<i>S, M, E, H,</i>	sizes 1/8 to 3 in.
Iron Body.....	<i>L, S, M, E, H,</i>	“ 2 to 12 in.

COCKS, STEAM AND GAS.

Brass.....	sizes 1/4 to 3 in.
Iron Body.....	“ 1/2 to 3 in.

*Nipples.*—Nipples are made in all sizes from 1/8 in. to 12 in. inclusive, in all lengths, either black or galvanized, and regular right-hand or right- and left-hand threads. (For table of nipples see National Tube Co.'s Book of Standards.) Long screws or tank nipples are made of extra heavy pipe because there is less danger of crushing or splitting them when screwing up.

*Screwed Fittings—Malleable Iron.*—Standard Malleable Iron Fittings are made both plain and beaded. The former are generally used for low pressure gas and water, as in house plumbing and railing work. The beaded is the standard steam, air, gas, or oil fitting. Beaded fittings, in sizes 4 in. and smaller, are made in nearly every useful combination of openings. Sizes larger than 4 in. are not usually made reducing except by means of bushing. Extra heavy and hydraulic malleable iron fittings are flat bead, or banded.

*Screwed Fittings—Cast Iron.*—It is not considered good practice to use screwed cast-iron fittings of any kind in sizes larger than 6 in.

*Flanged Fittings.*—The flanges of the low pressure and standard are the same with the exception of the flange thickness, which is less on the low pressure. These flanges are known as the American Standard. (See pp. 209, 210.)

There is no recognized standard for flanges in hydraulic work.

*Unions.*—Unions are usually classified under two headings, Nut unions and Flange unions. Nut unions are commonly used in sizes 2 in. and smaller, and flange unions in sizes larger than 2 in. However, many manufacturers make nut unions as large as 4 in. and flange unions smaller than 2 in.

Nut unions are made in malleable iron, brass, and malleable iron, and all brass. The all malleable iron union (lip union) is the standard malleable iron union of the trade and requires a gasket. The brass and malleable iron union is a better union, because no gasket is required and there is no possibility of the parts rusting together. The pipe end of this union which carries an external thread, called the

thread end, upon which the nut or ring screws, is made of brass, and the other pipe end (called the bottom) and nut ring are made of malleable iron. The seat formed by the brass and iron pipe ends, when brought together, is truly spherical and the harder iron is sure to make a perfect joint with the softer brass.

All-brass unions are made with a spherical or conical seat, no gaskets being required. The finished all-brass union is often used where showy work is desired, such as oil piping for engines, etc.

Flange unions are made of malleable iron, malleable iron and brass, cast iron, and cast iron and brass.

The type of flange union recommended for standard work is made with a brass to iron non-corrosive ball joint seat which requires no gasket to make a tight joint even when the pipe alignment is imperfect. The flange is loose on the collar, so that the bolts match the holes in any position.

*Valves and Cocks.*—The most common means for regulating the flow of fluids in pipes is by means of valves and cocks, valves being preferred because of the easier operation and greater reliability. The common types of valves are straightway or gate, globe, and angle. A globe valve offers more resistance to the flow of any fluid than the straightway valve.

*Globe and Angle Valves.*—Many manufacturers make a globe and angle valve known as light standard or competition valve, but it is not recommended for any work except the lowest pressures, or where the valve will not be often opened or closed.

*Cocks.*—Among the modern types of cocks is one made with iron body and brass plug. This cock has an inverted plug with a spring at the bottom constantly pressing the plug against the seat, which reseats the plug if it should stick. These cocks are tested to 250 lb. cold-water pressure, and 125 lb. compressed-air pressure under water, and are recommended for 125 lb. working pressure.

*Blast Furnace Fittings.*—Tuyere cocks and tuyere unions used in blast furnace piping are always made of brass on account of ease in disconnecting, greater reliability of metal and resistance to corrosion from the impurities in the water, such as sulphuric acid.

### STANDARD PIPE FLANGES (CAST IRON).

The following tables showing dimensions of standard pipe flanges were adopted by the American Society of Mechanical Engineers, the Master Steam and Hot Water Fitters' Association, and a committee representing the manufacturers of pipe fittings. They represent a compromise between the standards adopted by the American Society of Mechanical Engineers and the Master Steam and Hot Water Fitters' Association in 1912, known as the 1912 U. S. Standard, and the standards adopted by a conference of manufacturers in July, 1912, known as the Manufacturers' standard. The new standards, given in the tables, are called the American Standard, and became effective Jan. 1, 1914. The table of flanges for extra heavy fittings is for working pressures up to 250 lb. per sq. in. The table for ordinary fittings is for working pressures up to 125 lb. per sq. in. In the tables, the values of stresses in pipe walls were calculated from the formula  $S = \frac{r \times p}{t}$ ,

where  $p$  = working pressure, lb. per sq. in.,  $t$  = thickness of pipe, in., and  $r$  = radius of pipe, in. The highest stress was found to be 2000 lb. per sq. in. on the 250-lb., 46- and 48-in. pipe walls, giving a factor of safety of about 10. The desirable thickness of pipe (Col. 2)

is calculated from the formula  $T = \left[ \frac{p + 100}{4 \times S} D + 0.333 \left( 1 - \frac{d}{100} \right) \right] 1.2$ .

where  $p$  = pressure, lb., per sq. in.,  $S$  = 1800, and  $d$  = diameter of pipe. The minimum thickness in even fractions of an inch is given in Col. 3. The following approximate formulæ were also used for ordinary fittings: Diam. of bolt circles =  $1.10 d + 3$ . Flange thickness (for pipe diameters 26 to 100 in. inclusive) =  $0.0315 d + 1.25$ . For extra heavy fittings the formulæ are: Bolt circle =  $1.171 d + 3.75$ ; Flange thickness =  $0.0546 d + 1.375$  (for sizes 10 to 48 in. inclusive).

American Standard Cast Iron Pipe Flanges for Pressures up to 125 Lb. per Sq. In. (All Dimensions in Inches.)

Diameter.	Pipe		Stress on Pipe, Lb. per Sq. In.	Flanges.			Bolt Circle Diam.	Bolts.				Bolt Hole Diam.	See Fig. 75, p. 210		
	Thickness			Diameter.	Thickness.	Width of Face.		Number.	Diameter.	Effective Area, Sq. in.	Stress Lb. per Sq. In.		A	B	C
	For- mula.	Mini- mum.													
1	0.43	7/16	143	4	7/16	1 1/2	3	4	7/16	0.093	264	9/16	2.12	0.91	1.21
1 1/4	0.44	7/16	178	4 1/2	1 1/2	1 5/8	3 3/8	4	7/16	0.093	412	9/16	2.38	0.91	1.47
1 1/2	0.45	7/16	214	5	9/16	1 3/4	3 7/8	4	1/2	0.126	438	5/8	2.73	1.00	1.73
2	0.46	7/16	286	6	5/8	2	4 3/4	4	5/8	0.202	486	3/4	3.35	1.21	2.14
2 1/2	0.48	7/16	357	7	11/16	2 1/4	5 1/2	4	5/8	0.202	750	3/4	3.88	1.21	2.67
3	0.50	7/16	428	7 1/2	3/4	2 1/4	6	4	5/8	0.202	1093	3/4	4.23	1.21	3.02
3 1/2	0.52	7/16	500	8 1/2	13/16	2 1/2	7	4	5/8	0.202	1488	3/4	4.94	1.21	3.73
4	0.53	1/2	500	9	15/16	2 1/2	7 1/2	8	5/8	0.202	972	3/4	2.87	1.21	1.56
4 1/2	0.55	1/2	562	9 1/4	15/16	2 3/8	7 3/4	8	3/4	0.302	823	7/8	2.96	1.44	1.52
5	0.56	1/2	625	10	15/16	2 1/2	8 1/2	8	3/4	0.302	1016	7/8	3.25	1.44	1.81
6	0.60	9/16	667	11	1	2 1/2	9 1/2	8	3/4	0.302	1463	7/8	3.63	1.44	2.19
7	0.63	5/8	700	12 1/2	1 1/16	2 3/4	10 3/4	8	3/4	0.302	1991	7/8	4.11	1.44	2.67
8	0.66	5/8	800	13 1/2	1 1/8	2 3/4	11 3/4	8	3/4	0.302	2600	7/8	4.50	1.44	3.06
9	0.70	11/16	818	15	1 1/8	3	13 1/4	12	3/4	0.302	2194	7/8	3.43	1.44	1.99
10	0.73	3/4	833	16	1 3/16	3	14 1/4	12	7/8	0.420	1948	1	3.69	1.66	2.03
12	0.80	13/16	923	19	1 1/4	3 1/2	17	12	7/8	0.420	2805	1	4.40	1.66	2.74
14	0.86	7/8	1000	21	1 3/8	3 1/2	18 3/4	12	1	0.550	2915	1 1/8	4.86	1.88	2.98
15	0.90	7/8	1072	22 1/4	1 3/8	3 5/8	20	16	1	0.550	2510	1 1/8	3.90	1.88	2.02
16	0.93	1	1000	23 1/2	1 7/16	3 3/4	21 1/4	16	1	0.550	2856	1 1/8	4.14	1.88	2.26
18	1.00	1 1/16	1059	25	1 9/16	3 1/2	22 3/4	16	1 1/8	0.694	2865	1 1/4	4.44	2.09	2.35
20	1.07	1 1/8	1111	27 1/2	1 11/16	3 3/4	25	20	1 1/8	0.694	2829	1 1/4	3.91	2.09	1.82
22	1.13	1 3/16	1158	29 1/2	1 13/16	3 3/4	27 1/4	20	1 1/4	0.893	2660	1 3/8	4.26	2.31	1.95
24	1.20	1 1/4	1200	32	1 7/8	4	29 1/2	20	1 1/4	0.893	3166	1 3/8	4.62	2.31	2.31
26	1.27	1 5/16	1238	34 1/2	2	4 1/8	31 3/4	24	1 1/4	0.893	3096	1 3/8	4.14	2.31	1.83
28	1.33	1 3/8	1273	36 1/2	2 1/16	4 1/4	34	28	1 1/4	0.893	3078	1 3/8	3.81	2.31	1.50
30	1.40	1 7/16	1304	38 3/4	2 1/8	4 3/8	36	28	1 3/8	1.057	2985	1 1/2	4.03	2.53	1.50
32	1.47	1 1/2	1333	41 3/4	2 1/4	4 7/8	38 1/2	28	1 1/2	1.294	2775	1 5/8	4.31	2.75	1.56
34	1.54	1 9/16	1360	43 3/4	2 5/16	4 7/8	40 1/2	32	1 1/2	1.294	2741	1 5/8	3.97	2.75	1.22
36	1.60	1 5/8	1385	46	2 3/8	5	42 3/4	32	1 1/2	1.294	3073	1 5/8	4.19	2.75	1.44
38	1.67	11/16	1407	48 3/4	2 3/8	5 3/8	45 1/4	32	1 5/8	1.515	2924	1 3/4	4.43	2.96	1.47
40	1.73	1 3/4	1428	50 3/4	2 1/2	5 3/8	47 1/4	36	1 5/8	1.515	2880	1 3/4	4.11	2.96	1.15
42	1.82	1 13/16	1448	53	2 5/8	5 1/2	49 1/2	36	1 5/8	1.515	3175	1 3/4	4.31	2.96	1.35
44	1.87	1 7/8	1467	55 1/4	2 5/8	5 5/8	51 3/4	40	1 5/8	1.515	3136	1 3/4	4.06	2.96	1.10
46	1.94	15/16	1484	57 1/4	2 11/16	5 5/8	53 3/4	40	1 5/8	1.515	3428	1 3/4	4.22	2.96	1.26
48	2.00	2	1500	59 1/2	2 3/4	5 3/4	56	44	1 5/8	1.515	3393	1 3/4	3.98	2.96	1.02
50	2.07	2 1/16	1515	61 3/4	2 3/4	5 7/8	58 1/4	44	1 3/4	1.746	3195	1 7/8	4.14	3.19	0.95
52	2.14	2 1/8	1530	64	2 7/8	6	60 1/2	44	1 3/4	1.746	3456	1 7/8	4.30	3.19	1.11
54	2.20	2 3/16	1543	66 1/4	3	6 1/8	62 3/4	44	1 3/4	1.746	3726	1 7/8	4.45	3.19	1.26
56	2.27	2 1/4	1555	68 3/4	3	6 3/8	65	48	1 3/4	1.746	3674	1 7/8	4.26	3.19	1.07
58	2.34	2 5/16	1567	71	3 1/8	6 1/2	67 1/4	48	1 3/4	1.746	3941	1 7/8	4.40	3.19	1.21
60	2.41	2 7/16	1538	73	3 1/8	6 1/2	69 1/4	52	1 3/4	1.746	3892	1 7/8	4.19	3.19	1.00
62	2.47	2 1/2	1550	75 3/4	3 1/4	6 7/8	71 3/4	52	1 7/8	2.051	3538	2	4.34	3.41	0.93
64	2.54	2 9/16	1561	78	3 1/4	7	74	52	1 7/8	2.051	3770	2	4.48	3.41	1.07
66	2.61	2 5/8	1572	80	3 3/8	7	76	52	1 7/8	2.051	4010	2	4.60	3.41	1.19
68	2.68	2 11/16	1582	82 1/4	3 3/8	7 1/8	78 1/4	56	1 7/8	2.051	3952	2	4.38	3.41	0.97
70	2.74	2 3/4	1591	84 1/2	3 1/2	7 1/4	80 1/2	56	1 7/8	2.051	4188	2	4.51	3.41	1.10
72	2.81	2 13/16	1600	86 1/2	3 1/2	7 1/4	82 1/2	60	1 7/8	2.051	4136	2	4.33	3.41	0.92
74	2.88	2 7/8	1609	88 1/2	3 5/8	7 1/4	84 1/2	60	1 7/8	2.051	4368	2	4.44	3.41	1.03
76	2.94	2 15/16	1617	90 3/4	3 5/8	7 3/8	86 1/2	60	1 7/8	2.051	4608	2	4.54	3.41	1.13
78	3.01	3	1625	93	3 3/4	7 1/2	88 3/4	60	2	2.302	4325	2 1/8	4.66	3.63	1.03
80	3.08	3 1/16	1633	95 1/4	3 3/4	7 5/8	91	60	2	2.302	4549	2 1/8	4.78	3.63	1.15
82	3.15	3 1/8	1640	97 1/2	3 7/8	7 3/4	93 1/4	60	2	2.302	4779	2 1/8	4.90	3.63	1.27
84	3.21	3 3/16	1647	99 3/4	3 7/8	7 7/8	95 1/2	64	2	2.302	4702	2 1/8	4.68	3.63	1.05
86	3.28	3 1/4	1653	102	4	8	97 3/4	64	2	2.302	4928	2 1/8	4.79	3.63	1.16
88	3.35	3 5/16	1660	104 1/4	4	8 1/8	100	68	2	2.302	4857	2 1/8	4.60	3.63	0.97
90	3.41	3 3/8	1667	106 1/2	4 1/8	8 1/4	102 1/4	68	2 1/8	2.648	4416	2 1/4	4.71	3.83	0.88
92	3.48	3 1/2	1643	108 3/4	4 1/8	8 3/8	104 1/2	68	2 1/8	2.648	4615	2 1/4	4.81	3.83	0.98
94	3.55	3 9/16	1649	111	4 1/4	8 1/2	106 1/4	68	2 1/8	2.648	4817	2 1/4	4.89	3.83	1.06
96	3.62	3 5/8	1655	113 1/4	4 1/4	8 5/8	108 1/2	68	2 1/4	3.023	4401	2 3/8	4.99	4.06	0.93
98	3.68	3 11/16	1661	115 1/2	4 3/8	8 3/4	110 3/4	68	2 1/4	3.023	4587	2 3/8	5.09	4.06	1.03
100	3.75	3 3/4	1667	117 3/4	4 3/8	8 7/8	113	68	2 1/4	3.023	4776	2 3/8	5.20	4.06	1.14



The last three columns of the table refer to the sketch Fig. 75, and show the distances between bolt holes, the maximum space occupied by the nuts and the minimum space between adjacent nuts, all measured on the chord. Bolt holes are to straddle the center line, and are to be 1/8 in. larger in diameter than the bolts. Standard weight fittings and flanges are to be plain faced, but extra heavy fittings and flanges are to have a raised surface 1/16 in. high inside of bolt holes for gaskets. Square head bolts with hexagonal nuts are recommended, but for bolts 1 5/8 in. diameter and larger, studs with a nut on each end may be substituted. Flanges are to

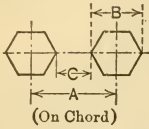

Fig. 75.

be spot bored for nuts for sizes 32 in. to 100 in. inclusive. For superheated steam, steel flanges, fittings and valves are recommended.

**American Standard Extra Heavy Cast Iron Pipe Flanges**

**For Pressures up to 250 Lb. per Sq. In. (All Dimensions in Inches.)**

Pipe Diameter.	Thickness		Stress on Pipe, Lb. per Sq. In.	Flanges.			Bolt Circle Diam.	Number.	Bolts.			Bolt Hole Diam.	See Fig. 75, p. 210.		
	For- mula.	Mini- mum.		Diam.	Thickness*	Width of Face.			Diameter, In.	Effective Area, Sq. In.	Stress Lb. per Sq. In.		A	B	C
1	0.45	1/2	250	4 1/2	11/16	1 3/4	3 1/4	4	1/2	0.126	389	5/8	2.29	1.00	1.29
1 1/4	0.47	1/2	312	5	3/4	1 7/8	3 3/4	4	1/2	0.126	609	5/8	2.65	1.00	1.65
1 1/2	0.49	1/2	375	6	13/16	2 1/4	4 1/2	4	5/8	0.202	547	3/4	3.17	1.21	1.96
2	0.51	1/2	500	6 1/2	7/8	2 1/4	5	4	5/8	0.202	972	3/4	3.53	1.21	2.32
2 1/2	0.53	9/16	555	7 1/2	1	2 1/2	5 7/8	4	3/4	0.302	1016	7/8	4.15	1.44	2.71
3	0.56	9/16	667	8 1/4	1 1/8	2 5/8	6 5/8	8	3/4	0.302	731	7/8	2.53	1.44	1.09
3 1/2	0.59	9/16	778	9	1 3/16	2 3/4	7 1/4	8	3/4	0.302	995	7/8	2.77	1.44	1.33
4	0.61	5/8	800	10	1 1/4	3	7 7/8	8	3/4	0.302	1300	7/8	3.01	1.44	1.57
4 1/2	0.64	5/8	900	10 1/2	1 5/16	3	8 1/2	8	3/4	0.302	1646	7/8	3.25	1.44	1.81
5	0.67	11/16	909	11	1 3/8	3	9 1/4	8	3/4	0.302	2032	7/8	3.53	1.44	2.09
6	0.72	3/4	1000	12 1/2	1 7/16	3 1/4	10 5/8	12	3/4	0.302	1950	7/8	2.75	1.44	1.31
7	0.78	13/16	1077	14	1 1/2	3 1/2	11 7/8	12	7/8	0.420	1909	1	3.07	1.66	1.41
8	0.83	13/16	1230	15	1 5/8	3 1/2	13	12	7/8	0.420	2493	1	3.36	1.66	1.70
9	0.89	7/8	1285	16 1/4	1 3/4	3 5/8	14	12	1	0.550	2410	1 1/8	3.62	1.88	1.74
10	0.94	15/16	1333	17 1/2	1 7/8	3 3/4	15 1/4	16	1	0.550	2231	1 1/8	2.97	1.88	1.09
12	1.05	1	1500	20 1/2	2	4 1/4	17 3/4	16	1 1/8	0.694	2546	1 1/4	3.46	2.09	1.37
14	1.16	1 1/8	1555	23	2 1/8	4 1/2	20 1/4	20	1 1/8	0.694	2773	1 1/4	3.17	2.09	1.08
15	1.21	1 3/16	1579	24 1/2	2 3/16	4 3/4	21 1/2	20	1 1/4	0.893	2473	1 3/8	3.36	2.31	1.05
16	1.27	1 1/4	1600	25 1/2	2 1/4	4 3/4	22 1/2	20	1 1/4	0.893	2814	1 3/8	3.52	2.31	1.21
18	1.37	1 3/8	1636	28	2 3/8	5	24 3/4	24	1 1/4	0.893	2968	1 3/8	3.23	2.31	0.92
20	1.48	1 1/2	1666	30 1/2	2 1/2	5 1/4	27	24	1 3/8	1.057	3096	1 1/2	3.52	2.53	0.99
22	1.59	1 9/16	1760	33	2 5/8	5 1/4	29 1/4	24	1 1/2	1.295	3058	1 5/8	3.81	2.75	1.05
24	1.70	1 5/8	1846	36	2 3/4	5 3/4	32	24	1 5/8	1.515	3110	1 3/4	4.18	2.96	1.22
26	1.81	1 13/16	1793	38 1/4	2 13/16	6 1/8	34 1/2	28	1 5/8	1.515	3126	1 3/4	3.86	2.96	0.90
28	1.91	1 7/8	1866	40 3/4	2 15/16	6 3/8	37	28	1 5/8	1.515	3629	1 3/4	4.14	2.96	1.18
30	2.02	2	1875	43	3	6 1/2	39 1/4	28	1 3/4	1.746	3615	1 7/8	4.38	3.19	1.19
32	2.13	2 1/8	1882	45 1/4	3 1/8	6 5/8	41 1/2	28	1 7/8	2.051	3501	2	4.64	3.41	1.26
34	2.24	2 1/4	1889	47 1/2	3 1/4	6 3/4	43 1/2	28	1 7/8	2.051	3952	2	4.87	3.41	1.46
36	2.35	2 3/8	1894	50	3 3/8	7	46	32	1 7/8	2.051	3877	2	4.50	3.41	1.09
38	2.46	2 7/16	1848	52 1/4	3 7/16	7 1/8	48	32	1 7/8	2.051	4320	2	4.70	3.41	1.29
40	2.56	2 9/16	1953	54 1/2	3 9/16	7 1/4	50 1/4	36	1 7/8	2.051	4255	2	4.38	3.41	0.97
42	2.67	2 11/16	1953	57	3 11/16	7 1/2	52 3/4	36	1 7/8	2.051	4691	2	4.59	3.41	1.18
44	2.78	2 13/16	1955	59 1/4	3 3/4	7 5/8	55	36	2	2.302	4587	2 1/8	4.79	3.63	1.16
46	2.89	2 7/8	2000	61 1/2	3 7/8	7 3/4	57 1/4	40	2	2.302	4512	2 1/8	4.49	3.63	0.86
48	3.00	3	2000	65	4	8 1/2	60 3/4	40	2	2.302	4913	2 1/8	4.76	3.63	1.13

\* Thickness of flange given in table includes raised face.



**Forged Steel Flanges for Riveted Pipe.**  
Riveted Pipe Manufacturers' Standard.\*

Nominal Size, Ins.	Outside Diam.	Thickness of Flange.*	No. of Bolts.	Size of Bolts.	Diam. of Bolt Circle.	Nominal Size, Ins.	Outside Diam.	Thickness of Flange.*	No. of Bolts.	Size of Bolts.	Diam. of Bolt Circle
3	6	5/16 . . . .	4	7/16	4 3/4	16	21 1/4	5/8 3/4	12	1/2	19 1/4
4	7	5/16 9/16	8	7/16	5 15/16	18	23 1/4	5/8 3/4	16	5/8	21 1/4
5	8	5/16 9/16	8	7/16	6 15/16	20	25 1/4	5/8 7/8	16	5/8	23 1/8
6	9	3/8 9/16	8	1/2	7 7/8	22	28 1/4	11/16 7/8	16	5/8	26
7	10	3/8 9/16	8	1/2	9	24	30	11/16 7/8	16	5/8	27 3/4
8	11	3/8 5/8	8	1/2	10	26	32	. . . . 1	24	3/4	29 3/4
9	13	3/8 5/8	8	1/2	11 1/4	28	34	. . . . 1	28	3/4	31 3/4
10	14	3/8 11/16	8	1/2	12 1/4	30	36	. . . . 1	28	3/4	33 3/4
11	15	7/16 . . . .	12	1/2	13 3/8	32	38	. . . . .	28	3/4	35 3/4
12	16	7/16 3/4	12	1/2	14 1/4	34	40	. . . . .	28	3/4	37 3/4
13	17	7/16 . . . .	12	1/2	15 1/4	36	42	. . . . 11/8	32	3/4	39 3/4
14	18	7/16 3/4	12	1/2	16 1/4	40	46	. . . . 11/8	32	3/4	43 3/4
15	19	9/16 3/4	12	1/2	17 7/16	42	48	. . . . 11/8	36	3/4	45 3/4

\* Flanges for riveted pipe are also made with the outside diameter and the drilling dimensions the same as those of the A. S. M. E. standard (page 209), and with the thickness as given in the second column of figures under "Thickness of Flange" in the above table.

Curved Forged Steel Flanges are also made for boilers and tanks, See catalogue of American Spiral Pipe Works, Chicago.

**Forged and Rolled Steel Flanges.**

Dimensions in Inches. (American Spiral Pipe Works, 1913.)

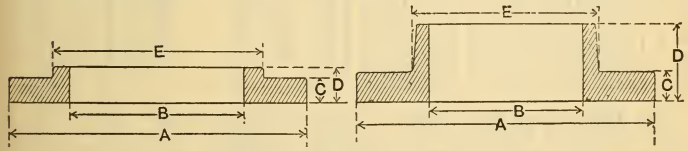

**Standard Companion Flanges.**

**Standard Shrink Flanges.**

Nominal Size, Inches.	Outside Diam.	Actual Bore	Thick-ness.	Depth of Hub.	Diam. of Hub.	Nominal Size, Inches.	Outside Diam.	Bore Diam.	Thick-ness.	Depth of Hub.	Diam. of Hub.
	A	B	C	D	E		A	B	C	D	E
2	6	2 1/8	5/8	1	5 1/8	4	9	4 3/8	15/16	23/16	5 3/4
2 1/2	7	2 1/2	11/16	1 1/16	35/8	4 1/2	9 1/4	4 7/8	15/16	2 1/4	6 1/8
3	7 1/2	3 1/8	3/4	1 1/8	4 5/8	5	10	5 7/16	15/16	2 5/16	6 7/8
3 1/2	8 1/2	3 5/8	13/16	1 3/16	4 7/8	6	11	6 1/2	1	2 7/16	7 7/8
4	9	4 1/8	15/16	1 3/8	5 3/8	7	12 1/2	7 1/2	1 1/16	2 1/2	9
4 1/2	9 1/4	4 5/8	15/16	1 1/4	5 13/16	8	13 1/2	8 1/2	1 1/8	2 5/8	10
5	10	5 1/8	15/16	1 5/8	6 7/16	9	15	9 1/2	1 1/8	2 3/4	11 1/8
6	11	6 3/8	1	1 7/8	7 9/16	10	15	10 5/8	1 3/16	3	12 1/4
7	12 1/2	7 3/8	1 1/16	1 1/2	8 5/8	12	19	12 5/8	1 1/4	3 3/8	14 1/2
8	13 1/2	8 3/8	1 1/8	1 5/8	9 11/16	14	21	13 7/8	1 3/8	3 3/8	15 7/8
9	15	9 3/8	1 1/8	1 3/4	10 5/8	15	22 1/4	14 7/8	1 3/8	3 1/2	16 7/8
10	16	10 5/8	1 3/16	1 7/8	11 15/16	16	23 1/2	15 7/8	1 7/8	3 5/8	18
12	19	12 5/8	1 1/4	2 1/8	14 1/8	18	25	17 7/8	1 9/16	3 7/8	20 1/8
14	21	13 1/2	1 3/8	2 3/8	15 7/16	20	27 1/2	19 7/8	1 11/16	4 1/8	22 1/4

## Forged and Rolled Steel Flanges.—Continued.

## Extra Heavy Companion Flanges.

Nominal Size, Ins.	Outside Diam.	Bore Diam.	Thick-ness.	Depth of Hub.	Diam of Hub.	Nominal Size, Ins.	Outside Diam.	Bore Diam.	Thick-ness.	Depth of Hub.	Diam. of Hub.
	A	B	C	D	E		A	B	C	D	E
2	6 1/2	2 1/8	7/8	3/8	3 3/8	7	14	7 3/16	1 5/16	2 1/16	9 1/8
2 1/2	7 1/2	2 1/2	1	1 7/16	4 1/16	8	15	8 3/16	1 3/8	2 3/16	10 1/8
3	8 1/4	3 1/8	1	1 9/16	4 11/16	9	16	9 3/16	1 7/16	2 1/4	11 3/16
3 1/2	9	3 5/8	1 1/8	1 5/8	5 5/16	10	17 1/2	10 5/16	1 1/2	2 3/8	12 9/16
4	10	4 1/8	1 1/8	1 3/4	5 13/16	12	20	12 5/16	1 5/8	2 9/16	14 5/8
4 1/2	10 1/2	4 5/8	1 1/4	1 13/16	6 1/4	14	22 1/2	13 1/2	1 3/4	2 11/16	15 13/16
5	11	5 1/8	1 1/4	1 7/8	6 13/16	15	23 1/2	14 1/2	1 13/16	2 13/16	17 3/16
6	12 1/2	6 3/16	1 1/4	2	7 7/8	16	25	15 1/2	1 7/8	3 1/16	18 1/4

## Extra Heavy High Hub Flanges.

Size.	A	B	C	D	E	Size.	A	B	C	D	E
4	10	4 3/8	1 1/8	3 1/8	5 3/4	18	27	17 7/8	2	5	20 3/4
4 1/2	10 1/2	4 7/8	1 1/4	3 1/4	6 1/4	20	29 1/2	19 7/8	2 1/4	5 1/2	22 1/2
5	11	5 7/16	1 1/4	3 1/4	7	22	31 1/2		2 1/4	5 1/2	24 3/4
6	12 1/2	6 1/2	1 1/4	3 1/4	7 15/16	24	34		2 7/16	6 1/4	27
7	14	7 1/2	1 5/16	3 3/8	9 1/8	30	40		2 7/16	6 1/4	33
8	15	8 1/2	1 3/8	3 1/2	10 5/16	36	46		2 7/16	6 1/4	39
9	16	9 1/2	1 7/16	3 5/8	11 3/8	42	52		2 7/16	6 1/4	45
10	17 1/2	10 5/8	1 1/2	3 3/4	12 5/8	48	58 1/4		2 7/16	6 1/2	51 1/4
11	18 3/4	11 5/8	1 9/16	3 7/8	13 5/8	54	64 1/2		2 7/16	6 1/2	57 1/4
12	20	12 5/8	1 5/8	4	14 3/4	60	70 3/8		2 7/16	6 1/2	63 3/8
14	22 1/2	13 7/8	1 3/4	4 3/8	16 3/16	66	77		2 7/16	7 1/2	69 1/2
15	23 1/2	14 7/8	1 13/16	4 1/2	17 1/4	72	83 1/8		2 7/16	7 1/2	75 5/8
16	25	15 7/8	1 7/8	4 3/4	18 1/2						

**The Rockwood Pipe Joint.**—The system of flanged joints now in common use for high pressures, made by slipping a flange over the pipe, expanding the end of the pipe by rolling or peening, and then facing it in a lathe, so that when the flanges of two pipes are bolted together the bearing of the joint is on the ends of the pipes themselves and not on the flanges, was patented by George I. Rockwood, April 5, 1897, No. 580,058, and first described in *Eng. Rec.*, July 20, 1895. The joint as made by different manufacturers is known by various trade names, as Walmanco, Van Stone, etc.

**Matheson Joint and Converse Lock-joint Pipe.**—Sizes, external diameters 2 to 20 in., 22, 24, 26, 28, and 30 in. Kimberley Joint Pipe, 6 to 30 in. These pipes are considerably lighter than standard pipe. The Converse and Kimberley joints are made with special forms of external hubs, filled and calked with lead. The Matheson joint is also a lead-packed joint, but the bell or socket is made by expanding one of the pipes, the end being reinforced by a steel band. The lead required per joint is less than for other lead-joint pipes of the same diameter.

## PIPE FITTINGS.

**Dimensions of Standard Cast-Iron Flanged Pipe Fittings, for Pressures up to 125 Lb. per Sq. In.** (Adopted March 20, 1914, by a joint committee of manufacturers and of the Am. Soc. M. E.) Dimensions in the tables, pages 213 and 214, refer to corresponding letters on the sketches on page 215. For dimensions of flanges and bolts see Table of Standard Flanges, pages 209 and 210.

**Standard Cast Iron Flanged Pipe Fittings for Pressures up to 125 lb.  
per Sq. In. (see sketches p. 215.)**

Size.	Tees, Crosses and Ells.		Long Radius Ells.	45 degree Ells.	Laterals.			Reducers.	Min. Thickness of Metal.
	A-A	A			B	C	D		
1	7	3 1/2	5	1 3/4	7 1/2	5 3/4	1 3/4	.....	7/16
1 1/4	7 1/2	3 3/4	5 1/2	2	8	6 1/4	1 3/4	.....	7/16
1 1/2	8	4	6	2 1/4	9	7	2	.....	7/16
2	9	4 1/2	6 1/2	2 1/2	10 1/2	8	2 1/2	.....	7/16
2 1/2	10	5	7	3	12	9 1/2	2 1/2	.....	7/16
3	11	5 1/2	7 3/4	3	13	10	3	6	7/16
3 1/2	12	6	8 1/2	3 1/2	14 1/2	11 1/2	3	6 1/2	7/16
4	13	6 1/2	9	4	15	12	3	7	1/2
4 1/2	14	7	9 1/2	4	15 1/2	12 1/2	3	7 1/2	1/2
5	15	7 1/2	10 1/4	4 1/2	17	13 1/2	3 1/2	8	1/2
6	16	8	11 1/2	5	18	14 1/2	3 1/2	9	9/16
7	17	8 1/2	12 3/4	5 1/2	20 1/2	16 1/2	4	10	5/8
8	18	9	14	5 1/2	22	17 1/2	4 1/2	11	5/8
9	20	10	15 1/4	6	24	19 1/2	4 1/2	11 1/2	11/16
10	22	11	16 1/2	6 1/2	25 1/2	20 1/2	5	12	3/4
12	24	12	19	7 1/2	30	24 1/2	5 1/2	14	13/16
14	28	14	21 1/2	7 1/2	33	27	6	16	7/8
15	29	14 1/2	22 3/4	8	34 1/2	28 1/2	6	17	7/8
16	30	15	24	8	36 1/2	30	6 1/2	18	1
18	33	16 1/2	26 1/2	8 1/2	39	32	7	19	1 1/16
20	36	18	29	9 1/2	43	35	8	20	1 1/8
22	40	20	31 1/2	10	46	37 1/2	8 1/2	22	1 3/16
24	44	22	34	11	49 1/2	40 1/2	9	24	1 1/4
26	46	23	36 1/2	13	53	44	9	26	1 5/16
28	48	24	39	14	56	46 1/2	9 1/2	28	1 3/8
30	50	25	41 1/2	15	59	49	10	30	1 7/16
32	52	26	44	16	.....	.....	.....	32	1 1/2
34	54	27	46 1/2	17	.....	.....	.....	34	1 9/16
36	56	28	49	18	.....	.....	.....	36	1 5/8
38	58	29	51 1/2	19	.....	.....	.....	38	1 11/16
40	60	30	54	20	.....	.....	.....	40	1 3/4
42	62	31	56 1/2	21	.....	.....	.....	42	1 13/16
44	64	32	59	22	.....	.....	.....	44	1 7/8
46	66	33	61 1/2	23	.....	.....	.....	46	1 15/16
48	68	34	64	24	.....	.....	.....	48	2
50	70	35	66 1/2	25	.....	.....	.....	50	2 1/16
52	74	37	69	26	.....	.....	.....	52	2 1/8
54	78	39	71 1/2	27	.....	.....	.....	54	2 3/16
56	82	41	74	28	.....	.....	.....	56	2 1/4
58	84	42	76 1/2	29	.....	.....	.....	58	2 5/16
60	88	44	79	30	.....	.....	.....	60	2 7/16
62	90	45	81 1/2	31	.....	.....	.....	62	2 1/2
64	94	47	84	32	.....	.....	.....	64	2 9/16
66	96	48	86 1/2	33	.....	.....	.....	66	2 5/8
68	100	50	89	34	.....	.....	.....	68	2 11/16
70	102	51	91 1/2	35	.....	.....	.....	70	2 3/4
72	106	53	94	36	.....	.....	.....	72	2 13/16
74	108	54	96 1/2	37	.....	.....	.....	74	2 7/8
76	112	56	99	38	.....	.....	.....	76	2 15/16
78	116	58	101 1/2	39	.....	.....	.....	78	3
80	118	59	104	40	.....	.....	.....	80	3 1/16
82	120	60	106 1/2	41	.....	.....	.....	82	3 1/8
84	124	62	109	42	.....	.....	.....	84	3 3/16
86	126	63	111 1/2	43	.....	.....	.....	86	3 1/4
88	130	65	114	44	.....	.....	.....	88	3 5/16
90	134	67	116 1/2	45	.....	.....	.....	90	3 3/8
92	136	68	119	46	.....	.....	.....	92	3 1/2
94	138	69	121 1/2	47	.....	.....	.....	94	3 9/16
96	142	71	124	48	.....	.....	.....	96	3 5/8
98	146	73	126 1/2	49	.....	.....	.....	98	3 11/16
100	148	74	129	50	.....	.....	.....	100	3 3/4

**Dimensions of American Standard Flanged Reducing Fittings. Short Body Pattern.** (All Dimensions in Inches.)

Long body patterns are used when outlets are larger than those in table, and have the same dimensions as straight size fittings. All reducing fittings from 1 to 16 in. inclusive have same dimensions as straight size fittings. The dimensions of reducing fittings are always regulated by the reduction of the outlet.

Size.	Tees, Ells, Crosses.				Laterals.				Size.	Tees, Ells, and Crosses.				
	Max. Size of Outlet.	AA	A	B	Max. Size of Outlet.	D	E	F		H	Max. Size of Outlet.	AA	A	B
18	12	26	13	15 1/2	9	26	25	1	27 1/2	60	40	66	33	41
20	14	28	14	17	10	28	27	1	29 1/2	62	40	66	33	42
22	15	28	14	18	10	29	28 1/2	1/2	31 1/2	64	42	68	34	44
24	16	30	15	19	12	32	31 1/2	1/2	34 1/2	66	44	70	35	45
26	18	32	16	20	12	35	35	0	38	68	44	70	35	46
28	18	32	16	21	14	37	37	0	40	70	46	74	37	47
30	20	36	18	23	15	39	39	0	42	72	48	80	40	48
32	20	36	18	24	..	..	....	..	....	74	48	80	40	49
34	22	38	19	25	..	..	....	..	....	76	50	84	42	50
36	24	40	20	26	..	..	....	..	....	78	52	86	43	52
38	24	40	20	28	..	..	....	..	....	80	52	86	43	53
40	26	44	22	29	..	..	....	..	....	82	54	88	44	54
42	28	46	23	30	..	..	....	..	....	84	56	94	47	56
44	28	46	23	31	..	..	....	..	....	86	56	94	47	57
46	30	48	24	33	..	..	....	..	....	88	58	96	48	58
48	32	52	26	34	..	..	....	..	....	90	60	100	50	61
50	32	52	26	35	..	..	....	..	....	92	60	100	50	62
52	34	54	27	36	..	..	....	..	....	94	62	104	52	63
54	36	58	29	37	..	..	....	..	....	96	64	106	53	64
56	36	58	29	39	..	..	....	..	....	98	64	106	53	65
58	38	62	31	40	..	..	....	..	....	100	66	110	55	67

**Extra Heavy American Standard Flanged Reducing Fittings. Short Body Pattern.** (All Dimensions in Inches.)

Size.	Tees, Ells and Crosses.				Laterals.				Size.	Tees, Ells and Crosses.			
	Max. Size of Outlet.	AA	A	K	Max. Size of Outlet.	D	E	F		H	Max. Size of Outlet.	AA	A
18	12	28	14	17	9	34	31	3	32 1/2	34	22	44	28
20	14	31	15 1/2	18 1/2	10	37	34	3	36	36	24	47	29 1/2
22	15	33	16 1/2	20	10	40	37	3	39	38	24	47	30 1/2
24	16	34	17	21 1/2	12	44	41	3	43	40	26	50	31 1/2
26	18	38	19	23	..	..	..	..	..	42	28	53	33 1/2
28	18	38	19	24	..	..	..	..	..	44	28	53	34 1/2
30	20	41	20 1/2	25 1/2	..	..	..	..	..	46	30	55	35 1/2
32	20	41	20 1/2	26 1/2	..	..	..	..	..	48	32	58	37 1/2

**Standard Brass Flanges** as adopted Sept. 17, 1913, by the Committee of manufacturers on the standardization of Valves and Fittings, to become effective Jan. 1, 1914 are listed on page 215. The bolt holes for these flanges are to be drilled 1/16 in. greater than the bolt diameter for sizes 2 in. and smaller, and 1/8 in. greater than the bolt diameter for sizes 2 1/2 in. and larger. The flanges have smooth, plain faces, and when coupled to extra heavy iron flanges, the latter should have the raised surface faced off.



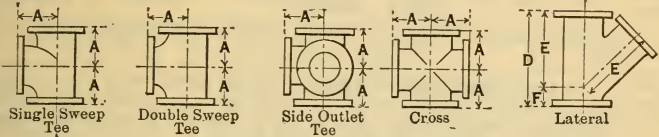
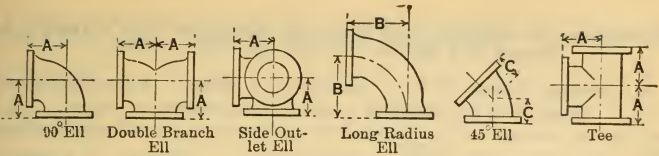

STRAIGHT SIZE FITTINGS.

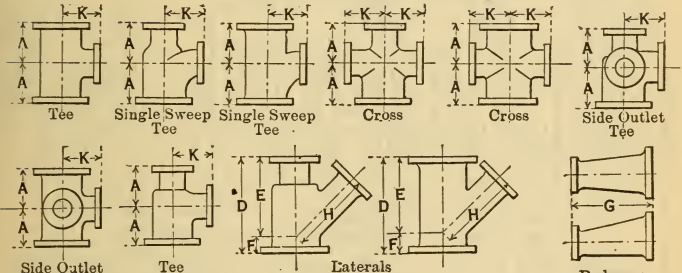

REDUCING FITTINGS.

The dimensions on these sketches refer to the corresponding letters in the tables of flanged fittings, pages 213 and 214, and also to the reference letters in the tables of screwed fittings, page 216.

Standard Brass Flanges.

Size, In.	Standard—For Pressures up to 125 Lb.					Extra Heavy—For Pressures up to 250 Lb.				
	Diam., In.	Thick-ness, In.	Bolt Circle, In.	No. of Bolts.	Size of Bolts, In.	Diam., In.	Thick-ness, In.	Bolt Circle, In.	No. of Bolts.	Size of Bolts, In.
1/4 & 3/8	2 1/2	9/32	1 11/16	4	3/8	3	3/8	2	4	7/16
1/2	3	5/16	2 1/8	4	3/8	3 1/2	13/32	2 3/8	4	7/16
3/4	3 1/2	11/32	2 1/2	4	3/8	4	7/16	2 7/8	4	1/2
1	4	3/8	3	4	7/16	4 1/2	1/2	3 1/4	4	1/2
1 1/4	4 1/2	13/32	3 3/8	4	7/16	5	11/32	3 3/4	4	1/2
1 1/2	5	7/16	3 7/8	4	1/2	6	9/16	4 1/2	4	5/8
2	6	1/2	4 3/4	4	5/8	6 1/2	5/8	5	4	5/8
2 1/2	7	9/16	5 1/2	4	5/8	7 1/2	11/16	5 7/8	4	3/4
3	7 1/2	5/8	6	4	5/8	8 1/4	3/4	6 5/8	8	3/4
3 1/2	8 1/2	11/16	7	4	5/8	9	13/16	7 1/4	8	3/4
4	9	11/16	7 1/2	8	5/8	10	7/8	7 7/8	8	3/4
4 1/2	9 1/4	23/32	7 3/4	8	3/4	10 1/2	7/8	8 1/2	8	3/4
5	10	3/4	8 1/2	8	3/4	11	15/16	9 1/4	8	3/4
6	11	13/16	9 1/2	8	3/4	12 1/2	1	10 5/8	12	3/4
7	12 1/2	7/8	10 3/4	8	3/4	14	1 1/16	11 7/8	12	7/8
8	13 1/2	15/16	11 3/4	8	3/4	15	1 1/8	13	12	7/8
9	15	15/16	13 1/4	12	3/4	16 1/4	1 1/8	14	12	1
10	16	1	14 1/4	12	7/8	17 1/2	1 3/16	15 1/4	16	1
12	19	1 1/16	17	12	7/8	20 1/2	1 1/4	17 3/4	16	1 1/8

### Dimensions of Screwed Cast Iron and Malleable Pipe Fittings, For Steam and Water. (Crane Co., Chicago, 1914.)

R = regular fitting; E.H. = extra heavy fitting. For meaning of dimensions see sketches p. 215. Dimensions in inches.

Fitting.	Tee, Cross, Ell.			Long Rad. Ell.	45 Deg. Ell.			Lateral.		Reducer.*	
	A			B	C			D	E	G	
Dimension.	Cast Iron.		Mall.	Mall.	Cast Iron.		Mall.	C. I.	C. I.	C. I.	Mall.
Size, Ins.	R.	E. H.	E. H.	E. H.	R.	E. H.	E. H.	R.	R.	R.	E. H.
1/4	13/16	.....	1 1/16	...	3/4	.....	3/4	.....	.....	.....	.....
3/8	15/16	.....	1 1/4	...	13/16	.....	7/8	.....	.....	.....	.....
1/2	1 1/8	.....	1 1/2	...	7/8	.....	1	2 1/2	17/8	.....	.....
3/4	1 5/16	.....	1 3/4	...	1	.....	1 1/8	3	2 1/4	.....	1 11/16
1	1 7/16	2	2	2 1/2	1 1/8	1 3/8	1 5/16	3 1/2	2 3/4	.....	2
1 1/4	1 3/4	2 1/4	2 1/4	3	1 5/16	1 1/2	1 1/2	4 1/4	3 1/4	2 1/8	2 3/8
1 1/2	1 15/16	2 9/16	2 1/2	3 1/2	1 7/16	1 5/8	1 11/16	4 7/8	3 13/16	2 1/4	2 11/16
2	2 1/4	3	3	4	1 11/16	1 15/16	2	5 3/4	4 1/2	2 7/16	2 3/16
2 1/2	2 11/16	3 1/2	3 1/2	4 3/4	1 15/16	2 1/4	2 1/4	6 1/4	5 3/16	2 11/16	.....
3	3 1/8	4 1/8	4 1/8	5 1/2	2 3/16	2 1/2	2 1/2	7 7/8	6 1/8	2 15/16	.....
3 1/2	3 7/16	4 11/16	4 5/8	6 1/4	2 3/8	2 9/16	2 5/8	8 7/8	6 7/8	3 1/8	.....
4	3 3/4	5 1/8	5 1/8	7	2 5/8	2 3/4	2 13/16	9 3/4	7 5/8	3 3/8	.....
4 1/2	4 1/16	5 1/2	5 5/8	7 3/4	2 13/16	3	.....	11 5/8	9 1/4	3 5/8	.....
5	4 7/16	6 1/8	6 1/4	8 1/2	3 1/16	3 5/16	.....	11 5/8	9 1/4	3 7/8	.....
6	5 1/8	7 1/4	7 1/4	9 1/2	3 7/16	3 3/4	.....	13 7/16	10 3/4	4 3/8	.....
7	5 13/16	8 1/8	.....	.....	3 7/8	4	.....	15 1/4	12 1/4	4 13/16	.....
8	6 1/2	9 1/8	.....	.....	4 1/4	4 3/4	.....	16 15/16	13 5/8	5 1/4	.....
9	7 3/16	.....	.....	.....	4 11/16	.....	.....	20 11/16	16 3/4	5 11/16	.....
10	7 7/8	11 3/8	.....	.....	5 3/16	4 7/8	.....	20 11/16	16 3/4	6 3/16	.....
12	9 1/4	13 3/8	.....	.....	6	5 1/2	.....	24 1/8	19 5/8	7 1/8	.....

\* The reducers are for reducing from the size of pipe given to the next smaller size. In addition, malleable reducers are listed for 1 1/4 x 1/2, 1 1/2 x 1, 1 1/2 x 1/2, 2 x 1, 2 x 1/2. The dimension G given in the table is the same for these special fittings as for the regular fittings given above.

**Strength of Pipe Fittings.**—To determine the actual bursting strength of cast iron fittings, and also to determine the influence of form upon the strength, Crane Co. conducted experiments in which flanged fittings of different sizes and forms were tested to destruction by internal pressure. The experiments showed that the strength of ells is practically the same, regardless of degree, or whether the ell is straight or reducing sizes. Fittings of the same general shape as the tee or cross are of nearly the same strength, and relatively of about two-thirds the strength of an ell. The straight lateral has about one-third the strength of the ell. The following average figures of bursting strength of extra heavy tees and ells are condensed from the company's 1914 catalogue:

Size of fitting, ins.,	6	8	10	12	14	16	18	20	24
Thickness of metal, in.	3/4	13/16	15/16	1	1 1/8	1 3/16	1 1/4	1 5/16	1 1/2
Tees, Ferro-steel:									
Burst at, lb. persq. in.	2733	2250	2160	2033	1825	1700	1450	1275	1300
Tees, Cast Iron:									
Burst at, lb. persq. in.	1687	1350	1306	1380	1100	1025	600	750	700
Ells, Ferro-steel:									
Burst at, lb. persq. in.	3266	2725	2350	2133					
Ells, Cast Iron:									
Burst at, lb. persq. in.	2275	1625	1541	1275	1075	1250			

**Length of Thread on Pipe** that should be screwed into fittings to make a tight joint is given by Crane Co. as follows:

Size of pipe, in. . . . .	1/8	1/4	3/8	1/2	3/4	1	1 1/4	1 1/2	2	2 1/2	3
Length of thread, in.	1/4	3/8	3/8	1/2	1/2	9/16	5/8	5/8	11/16	15/16	1
Size of pipe, in. . . . .	3 1/2	4	4 1/2	5	6	7	8	9	10	12	
Length of thread, in.	1 1/16	1 1/16	1 1/8	1 3/16	1 1/4	1 1/4	1 5/16	1 3/8	1 1/2	1 5/8	

**VALVES.**

**Dimensions of Standard Globe, Angle and Cross Valves.**

(Crane Co., 1914.)

Iron Body, Brass Trimmings, with Yoke.

*Dimensions in Inches:* B, face to face, flanged; B/2, center to face, flanged (Angle and Cross Valves); C, diameter of flanges; D, thickness of flanges; S, center to top of stem, open; O, diameter of wheel.

Size.	B	B/2	C	D	S	O	Size.	B	B/2	C	D	S	O
2	8	4	6	5/8	10 3/4	6 1/2	7	16	8	12 1/2	1 1/16	20 1/2	14
2 1/2	8 1/2	4 1/4	7	11/16	11 1/4	6 1/2	8	17	8 1/2	13 1/2	1 1/8	23 3/4	16
3	9 1/2	4 3/4	7 1/2	3/4	12 3/4	7 1/2	10	20	10	16	1 3/16	28	18
3 1/2	10 1/2	5 1/4	8 1/2	13/16	13	7 1/2	12	24	12	19	1 1/4	34	20
4	11	5 1/2	9	15/16	15 1/4	9	14	28	14	21	1 3/8	38 1/2	24
4 1/2	12	6	9 1/4	15/16	15 1/4	9	15	30	15	22 1/4	1 3/8	38 1/2	24
5	13	6 1/2	10	15/16	17 1/4	10	16	32	16	23 1/2	1 7/16	41 1/2	27
6	14	7	11	1	19	12							

**Standard Straight-Way Gate Valves.** (Crane Co., 1914.)

Iron Body. Brass Trimmings. Wedge Gate.

*Dimensions in Inches:* A, nominal size; B, face to face, flanged; C, diam. of flanges; D, thickness of flanges; K, end to end, screwed; N, center to top of non-rising stem; O, diam. of wheel; S, center to top of rising stem, open; Y, center to outside of by-pass; P, size of by-pass; X, number of turns to open.

A	B	C	D	K	N	O	S	Y	P	X
2	7	6	5/8	5 7/16	11 3/4	6 1/2	14 1/2			7
2 1/2	7 1/2	7	11/16	5 7/8	12 3/4	6 1/2	16			8
3	8	7 1/2	3/4	6 1/8	14 1/4	7 1/2	19			10 1/4
3 1/2	8 1/2	8 1/2	13/16	6 1/2	15 1/4	7 1/2	21 1/4			10 1/8
4	9	9	15/16	6 7/8	16 1/4	9	24			8 3/4
4 1/2	9 1/2	9 1/4	15/16	7 1/8	17 5/8	9	25 1/2			9
5	10	10	15/16	7 3/8	19	10	28 1/2			11
6	10 1/2	11	1	7 3/4	20 3/4	12	31 3/4			12 5/8
7	11	12 1/2	1 1/16	8 1/4	23	12	37 1/4			15 1/4
8	11 1/2	13 1/2	1 1/8	8 3/4	26	14	41			16
9	12	15	1 1/8	9 1/4	28	14	44 3/4			18 3/4
10	13	16	1 3/16	9 7/8	30 1/4	16	50			20 1/2
12	14	19	1 1/4	11 5/8	35 1/4	18	57 1/4			24 1/8
14	15	21	1 3/8		39 1/4	20	66 3/4	19 1/2	2	28 1/4
15	15	22 1/4	1 3/8		41 1/8	20	69 3/4	21	2	31 1/2
16	16	23 1/2	1 7/16		44 1/4	22	75 1/4	23 3/4	3	33 1/4
18	17	25	1 9/16		48 3/4	24	86	24 3/4	3	35 1/2
20	18	27 1/2	1 11/16		52 1/2	24	91	27 3/4	4	42 1/4
22	19	29 1/2	1 13/16		55 1/2	27	100	29	4	46
24	20	32	1 7/8		62	30	109	30 1/2	4	50
26	23	34 1/4	2		65 7/8	30	117 1/2	32	4	65
28	26	36 1/2	2 1/16		70	36	125	33	4	80
30	30	38 3/4	2 1/8		75 1/2	36	133	34	4	92 1/2
36	36	45 3/4	2 3/8		83		158 1/2	39	6	108

### Extra Heavy Straight-Way Gate Valves.

Ferro-steel. Hard Metal Seats. Wedge Gate. (For meaning of letters, see p. 217.)

A	B	K	C	D	N	S	O	P	Y	X
1 1/4	6 1/2	5 1/2	5	3/4	8 3/4	10 5/8	5			12
1 1/2	7 1/2	6 1/4	6	13/16	9 5/8	12 1/4	5 1/2			11
2	8 1/2	7	6 1/2	7/8	10 1/2	13 3/4	6 1/2			14
2 1/2	9 1/2	8	7 1/2	1	12 7/8	16	7 1/2			15
3	11 1/8	9	8 1/4	1 1/8	14 5/8	19 1/2	9			14
3 1/2	11 7/8	10	9	1 3/16	15 1/2	22	10			16
4	12	11	10	1 1/4	17 3/4	24 1/2	12			18
4 1/2	13 1/4	12 1/4	10 1/2	1 5/16	18 3/4	27	12			21
5	15	13 1/2	11	1 3/8	20 1/4	29 3/4	14			23
6	15 7/8	15 7/8	12 1/2	1 7/16	23	34 1/8	16	1 1/4	13	28
7	16 1/4	16 1/4	14	1 1/2	24 3/4	38	18	1 1/4	14 1/8	30
8	16 1/2	16 1/2	15	1 5/8	28 3/4	42 3/4	20	1 1/2	15 7/8	34
9	17	17	16 1/4	1 3/4	30 1/2	47	20	1 1/2	16 3/8	40
10	18	18	17 1/2	1 7/8	33 3/4	52 3/4	22	1 1/2	16 7/8	39
12	19 3/4		20 1/2	2	37 1/4	60	24	2	19 7/8	46
14	22 1/2		23	2 1/8	42 3/4	67 3/4	24	2	20 5/8	52
15	22 1/2		24 1/2	2 3/16	42 3/4	67 3/4	24	2	20 5/8	52
16	24		25 1/2	2 1/4		75 1/4	27	3	25 1/4	60
18	26		28	2 3/8		82 1/4	30	3	26 1/2	67
20	28		30 1/2	2 1/2		91 1/2	30	4	30 1/2	74
22	29 1/2		33	2 5/8		101	36	4	32 1/4	82
24	31		36	2 3/4		109	36	4	33	88

For dimensions of Medium Valves and Extra Heavy Hydraulic Valves, see Crane Company's catalogue.

### NATIONAL STANDARD HOSE COPULINGS

Adopted by the National Board of Fire Underwriters, American Waterworks Association, New England Waterworks Association, National Firemen's Association, National Fire Protection Association.

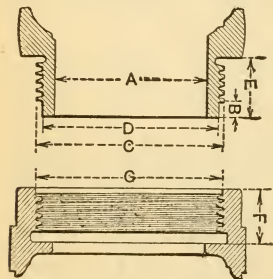

Dimensions in Inches.

A.....	2 1/2	3	3 1/2	4 1/2
B.....	1/4	1/4	1/4	1/4
C.....	3 1/16	3 5/8	4 1/4	5 3/4
D.....	2.8715	3.3763	4.0013	5.3970
E.....	1	1 1/8	1 1/8	1 3/8
N.....	7 1/2	6	6	4
F.....	7/8	1	1	1 1/4
G.....	3.0925	3.6550	4.28	5.80

The threads to be of the 60° V. pattern with 0.01 in. cut off the top of thread and 0.01 in. left in the bottom of the 2 1/2-in., 3-in., and 3 1/2-in. couplings, and 0.02 in. in like manner for the 4 1/2-in. couplings.

A = inside diameter of hose couplings, N = number of threads per inch.

### WOODEN STAVE PIPE.

Pipes made of wooden staves, banded with steel hoops, are made by the Excelsior Wooden Pipe Co., San Francisco, in sizes from 10 inches to 10 feet in diameter, and are extensively used for long-distance piping, especially in the Western States. The hoops are made of steel rods with upset and threaded ends. When buried below the hydraulic grade line and kept full of water, these pipes are practically indestructible. For the economic design and use of stave pipe see paper by A. L. Adams, *Trans. A. S. C. E.*, vol. xli.



**Weight and Strength of Riveted Hydraulic Pipe.**

(Pelton Water Wheel, San Francisco, 1915.)

Thickness.		4-in.		5-in.		6-in.		7-in.		8-in.	
Gauge.	In.	S	W	S	W	S	W	S	W	S	W
18	0.050	555	2.8	444	3.5	370	4.1	317	4.7	277	5.3
16	.062	693	3.7	555	4.4	462	5.2	396	5.9	346	6.7
14	.078	866	4.4	693	5.5	578	6.4	495	7.3	433	8.2
12	.109					808	8.8	693	10.0	605	11.5
10	.140									777	14.5
		9-in.		10-in.		11-in.		12-in.		14-in.	
16	0.062	308	7.5	277	8.3	252	9.0	231	9.9	198	11.4
14	.078	385	9.2	346	10.2	314	11.0	289	12.2	248	14.0
12	.109	539	12.6	485	14.2	439	15.2	404	16.7	346	19.2
10	.140	693	16.4	623	18.0	565	19.3	519	21.0	445	24.2
8	.171			761	21.5	693	23.5	635	25.6	543	29.5
	3/16			832	23.5	757	25.5	693	27.7	594	31.9
		15-in.		16-in.		18-in.		20-in.		22-in.	
16	0.062	185	12.0	173	12.8	154	14.5	139	16.0	126	17.7
14	.078	231	14.0	217	16.0	193	17.8	173	19.6	157	21.2
12	.109	323	20.3	303	21.5	270	24.4	242	27.3	220	29.2
10	.140	415	25.7	388	27.3	346	30.7	311	34.5	283	37.1
8	.171	507	30.4	475	33.3	422	38.4	380	41.5	346	45.2
	3/16	555	34.0	520	36.0	462	40.5	416	45.0	378	49.0
	1/4	739	45.5	693	48.2	616	54.1	555	59.6	505	65.5
	5/16			866	60.6	770	67.7	693	74.6	631	81.5
	3/8					924	81.3	831	89.5	757	98.0
	7/16							970	105.0	883	114.5
		24-in.		26-in.		30-in.		36-in.		42-in.	
14	0.078	144	23.7	133	25.5						
12	.109	202	32.5	186	34.5	162	39.5	134	47.7		
10	.140	259	40.5	239	43.7	208	50.3	173	60.0	148	69.5
8	.171	317	49.2	293	53.0	254	60.5	211	75.0	181	84.7
	3/16	346	53.0	320	57.5	277	65.5	231	79.0	198	91.5
	1/4	462	71.0	427	76.5	370	87.5	308	105.5	264	122.0
	5/16	578	88.5	533	95.5	462	109.0	385	130.0	330	151.0
	3/8	693	106.0	640	114.5	555	130.5	462	156.0	396	180.5
	7/16	808	124.5	747	134.0	647	151.5	539	182.5	462	211.0
	1/2	924	142.0	854	153.0	739	174.5	616	207.0	528	240.5
	5/8			1066	191.0	924	220.0	770	260.0	660	302.0
	3/4					1108	264.0	924	312.5	792	361.5
	7/8							1078	366.0	924	424.0
		48-in.		54-in.		60-in.		66-in.		72-in.	
8	0.171	158	98.0	141	110.0	127	121.0				
	3/16	173	106.0	154	119.0	139	131.0	127	144.5	115	158.0
	1/4	231	142.0	205	159.0	185	175.0	168	193.0	154	211.0
	5/16	289	177.0	256	198.0	231	218.0	210	239.0	193	260.0
	3/8	346	212.0	308	237.0	277	261.0	252	286.5	231	312.0
	7/16	404	249.0	359	277.5	323	303.0	294	334.0	270	365.0
	1/2	462	284.0	411	316.5	370	349.0	336	382.0	308	414.0
	5/8	578	354.0	513	399.5	462	440.0	420	480.0	385	520.0
	3/4	693	430.0	616	479.5	555	528.0	504	577.5	462	624.0
	7/8	808	505.0	719	563.5	647	620.0	588	677.0	539	732.0
	1	924	582.0	822	647.5	739	712.0	672	777.5	616	840.0

Pipe made of sheet steel plate, ultimate tensile strength 55,000 lbs. per sq. in., double-riveted longitudinal joints and single-riveted circular joints. Strength of longitudinal joints, 70%. Strain by safe pressure, 1/4 of ultimate strength.

**Riveted Iron Pipe.**

(Abendroth &amp; Root Mfg. Co.)

Sheets punched and rolled, ready for riveting, are packed in convenient form for shipment. The following table shows the iron and rivets required for punched and formed sheets.

Number Square Feet of Iron Required to Make 100 Lineal Feet Punched and Formed Sheets when put Together.			Approximate No. of Rivets 1 Inch apart Required for 100 Lineal Feet Punched and Formed Sheets.	Number Square Feet of Iron Required to Make 100 Lineal Feet Punched and Formed Sheets when put Together.			Approximate No. of Rivets 1 Inch apart Required for 100 Lineal Feet Punched and Formed Sheets.
Diameter in Inches.	Width of Lap in Inches.	Square Feet.		Diameter in Inches.	Width of Lap in Inches.	Square Feet.	
3	1	90	1600	14	1 1/2	397	2800
4	1	116	1700	15	1 1/2	423	2900
5	1 1/2	150	1800	16	1 1/2	452	3000
6	1 1/2	178	1900	18	1 1/2	506	3200
7	1 1/2	206	2000	20	1 1/2	562	3500
8	1 1/2	234	2200	22	1 1/2	617	3700
9	1 1/2	258	2300	24	1 1/2	670	3900
10	1 1/2	289	2400	26	1 1/2	725	4100
11	1 1/2	314	2500	28	1 1/2	779	4400
12	1 1/2	343	2600	30	1 1/2	836	4600
13	1 1/2	369	2700	36	1 1/2	998	5200

**Spiral Riveted Pipe.**

Approximate Bursting Strength. Pounds per Square Inch.  
(American Spiral Pipe Works, Chicago, 1915.)

Inside Diam. Inches.	Thickness. — U. S. Standard Gauge.								
	No. 20.	No. 18.	No. 16.	No. 14.	No. 12.	No. 10.	No. 8.	No. 6.	No. 3 (1/4").
3	1500	2000							
4	1125	1500	1875						
5	900	1200	1500						
6		1000	1250	1560	2170				
7		860	1070	1340	1860				
8		750	935	1170	1640				
9			835	1045	1460				
10			750	935	1310				
11			680	850	1200				
12			625	780	1080	1410			
13			575	720	1010	1295			
14			535	670	940	1210			
15				625	875	1125			
16				585	820	1050	1290	1520	1880
18				520	730	940	1140	1360	1660
20				470	660	840	1030	1220	1500
22				425	595	765	940	1108	1364
24				390	540	705	820	1015	1250
26					505	650	795	935	1154
28					470	605	735	870	1071
30					435	560	685	810	1000
32					410	525	645	760	940
34					380	490	600	715	880
36					365	470	570	680	830
40					330	420	515	610	750

**Weight per Sq. Ft. of Sheet Steel for Riveted Pipe.**

(American Spiral Pipe Works, Chicago, 1915.)

Thick- ness B.W.G.	Thick- ness, In.	Weight in Lb., Black.	Weight in Lb., Galvan- ized.	Thick- ness B.W.G.	Thick- ness, In.	Weight in Lb., Black.	Weight in Lb., Galvan- ized.
26	0.018	0.7344	0.8844	18	0.049	1.9992	2.1492
24	.022	0.8976	1.0476	16	.065	2.652	2.802
22	.028	1.1424	1.2924	14	.083	3.3864	3.5364
20	.035	1.428	1.578	12	.109	4.4472	4.5972

Weights based on steel of 489.6 lb. per cu. ft. Weights of galvanized sheets based on an addition of 0.075 lb. per sq. ft. of surface.

**BENT AND COILED PIPES.**

(National Pipe Bending Co., New Haven, Conn.)

**Coils and Bends of Iron and Steel Pipe.**

Size of pipe.....Inches	1/4	3/8	1/2	3/4	1	1 1/4	1 1/2	2	2 1/2	3
Least outside diameter of coil.....Inches	2	2 1/2	3 1/2	4 1/2	6	8	12	16	24	32
Size of pipe.....Inches	3 1/2	4	4 1/2	5	6	7	8	9	10	12
Least outside diameter of coil.....Inches	40	48	52	58	66	80	92	105	130	156

Lengths continuous welded up to 3-in. pipe or coupled as desired.

**90° Bends in Iron or Steel Pipe.**

(Whitlock Coil Pipe Co., Hartford, Conn.)

Size pipe, I.D.....	3	3 1/2	4	4 1/2	5	6	7	8	9	10	12
Radius of bend.....	12	13	15	17	20	23	26	30	36	42	48
End.....	3	3 1/2	3 1/2	4	4	4	5	5	5	6	6
Center to face.....	15	16 1/2	18 1/2	21	24	27	31	35	41	48	54
Size pipe, O.D.....	14	16	18	20	22	24	26	28	30	32	34
Radius of bend.....	60	70	80	90	100	110	120	140	160	180	200
End.....	7	7	7	8	8	8	10	10	10	10	10
Center to face.....	67	77	87	98	108	118	130	150	170	190	210

The radii given are for the center of the pipe. "End" means the length of straight pipe, in addition to the 90° bend, at each end of the pipe. "Center to face" means the perpendicular distance from the center of one end of the bent pipe to a plane passing across the other end. The dimensions given are the minimums recommended. Larger radii than are shown are recommended for flexibility and lesser friction.

**Flexibility of Pipe Bends.** (*Valve World*, Feb., 1906.)—So far as can be ascertained, no thorough attempt has ever been made to determine the maximum amount of expansion which a U-loop, or quarter bend, would take up in a straight run of pipe having both ends anchored. The Crane Company has adopted five diameters of the pipe as a standard radius, which comes nearer than any other to suiting average re-



quirements, and at the same time produces a symmetrical article. Bends shorter than this can be made, but they are extremely stiff, tend to buckle in bending, and the metal in the outer wall is stretched beyond a desirable point.

In 1905 the Crane Company made a few experiments with 8-inch U and quarter bends to ascertain the amount of expansion they would take up. The U-bend was made of steel pipe 0.32 inch thick, weighing 28 lbs. per foot, with extra heavy cast-iron flanges screwed on and refaced. It was connected by elbows to two straight pipes, N, 67 ft., S, 82 ft., which were firmly anchored at their outer ends. Steam was then let into the pipes with results as follows:

80 lb.	Expansion,		Total 1 7/8 in.	Flange broke.
50 lb.	Expansion, N, 7/8, S, 1 1/8.		Total 2 in.	
100 lb.	Expansion, N, 1 3/16, S, 1 1/2.		Total 2 11/16 in.	
150 lb.	Expansion, N, 1 1/8, S, 1 7/8.		Total 3 in.	
200 lb.	Expansion, N, 1 1/2, S, 1 7/8.		Total 3 3/8 in.	Flange broke at 208 lbs.

Quarter bend, full weight pipe. Straight pipe 148 ft., one end. 80 lbs. Total expansion, 1 3/8. Flange leaked.

Quarter bend, extra heavy pipe. Expanded 7/8 in. when a flange broke. Replaced with a new flange, which broke when the expansion was 1 1/8 in.

**Wrought Pipe Bends.** (National Tube Co.).—The following are given as the advisable (R) and the least allowable (R<sub>1</sub>) radii in inches to which pipe should be bent:

Size.	R.	R <sub>1</sub> .	Size.	R.	R <sub>1</sub> .	Size.	R.	R <sub>1</sub> .	Size.	R.	R <sub>1</sub> .	Size.	R.	R <sub>1</sub> .
2 1/2	15	10	4 1/2	27	18	8	48	32	12	72	48	18 O. D.	125	90
3	18	12	5	30	20	9	54	36	13	84	60	20 O. D.	150	120
3 1/2	21	14	6	36	24	10	60	40	14	90	68	22 O. D.	165	132
4	24	16	7	42	28	11	66	44	15	100	76	24 O. D.	180	144

Bends of 12-in. pipe and smaller to be of full weight pipe; 14 to 16 in. outside diameter, not less than 3/8 in. thick; 18 in. and larger, not less than 7/16 to 1/2 in. thick. With welded flanges there must be a short straight length of pipe, preferably equal to two diameters of the pipe, between the flange and the bend.

**Coils and Bends of Drawn Brass and Copper Tubing.**

Size of tube, outside diameter..Inches	1/4	3/8	1/2	5/8	3/4	1	1 1/4	1 3/8
Least outside diameter of coil..Inches	1	1 1/2	2	2 1/2	3	4	6	7
Size of tube, outside diameter..Inches	1 1/2	1 5/8	1 3/4	2	2 1/4	2 3/8	2 1/2	2 3/4
Least outside diameter of coil..Inches	8	9	10	12	14	16	18	20

Lengths continuous brazed, soldered, or coupled as desired.

**SEAMLESS TUBES.**

**Locomotive Boiler Tubes, Seamless.**—Diameters, external, 1 1/2, 1 3/4, 1 7/8, 2, 2 1/4, 2 1/2, and 3 in.

Nine thicknesses of  
 each size, inch... 0.095 .109 .110 .120 .125 .134 .135 .148 .150  
 Birmingham wire  
 gage..... 13 12 ... 11 ... 10 ... 9 ...

**Shelby Seamless Steel Tubes** are made of three classes of open-hearth steel: 0.17 C (0.14 to 0.19%); 0.35 C (0.30 to 0.40%); and 3 1/2% nickel (0.20 to 0.30 C, 3 to 4% nickel). In all, manganese is from 0.40 to 0.60%; sulphur, 0.015 to 0.040; phosphorus, 0.010 to 0.035%. Hot finished tubes are not given any heat treatment after





leaving the hot mills. Cold-drawn tubes are annealed before and heat-treated after drawing. The physical properties of finished material are as follows:

Temper		Tensile Strength.	Elastic Limit.	Elong. in 8 In., %.
0.17 C	S, unannealed . . .	65,000 to 80,000	60,000 to 70,000	3 to 7
	T, finish anneal. . .	60,000 to 75,000	50,000 to 65,000	10 to 16
	W, soft anneal . . .	47,000 to 55,000	27,000 to 35,000	28 to 33
	Y, retort anneal. . .	45,000 to 52,000	22,000 to 28,000	30 to 40
0.35 C	S, unannealed. . .	85,000 to 100,000	75,000 to 90,000	Low
	T, finish anneal. . .	80,000 to 95,000	70,000 to 85,000	12 to 18
	U, med. anneal. . .	65,000 to 80,000	50,000 to 60,000	20 to 30
31/2% Ni.	S, unannealed . . .	95,000 to 110,000	85,000 to 100,000	10 to 18 in 2"
	W, finish anneal. . .	85,000 to 105,000	75,000 to 90,000	15 to 25 in 2"
	U, med. anneal. . .	70,000 to 85,000	45,000 to 60,000	40 to 50 in 2"

The 0.17 C tube is also furnished in intermediate tempers. U, V, and X, between T and Y, and special treatments are given to order.

In estimating the effective steam-heating or boiler surface of tubes, the surface in contact with air or gases of combustion (whether internal or external to the tubes) is to be taken.

For heating liquids by steam, superheating steam, or transferring heat from one liquid or gas to another, the mean surface of the tubes is to be taken.

**Outside Area of Tubes.**

To find the square feet of surface, *S*, in a tube of a given length, *L*, in feet, and diameter, *d*, in inches, multiply the length in feet by the diameter in inches and by 0.2618. Or,  $S = \frac{3.1416 dL}{12} = 0.2618 dL$ . For the diameters in the table below, multiply the length in feet by the figures given opposite the diameter.

**Area of Tubes per Lineal Foot.**

Diam. In.	Area, Sq. Ft.	Diam. In.	Area, Sq. Ft.	Diam. In.	Area, Sq. Ft.	Diam. In.	Area, Sq. Ft.	Diam. In.	Area, Sq. Ft.	Diam. In.	Area, Sq. Ft.
1/4	0.0654	1 1/4	0.3272	2 1/4	0.5890	3 1/4	0.8508	5	1.3090	9	2.3562
1/2	.1309	1 1/2	.3927	2 1/2	.6545	3 1/2	.9163	6	1.5708	10	2.6180
3/4	.1963	1 3/4	.4581	2 3/4	.7199	3 3/4	.9817	7	1.8326	11	2.8798
1	.2618	2	.5236	3	.7854	4	1.0472	8	2.0944	12	3.1416

**Seamless Brass and Copper Tube, Iron Pipe Sizes.**

Nominal Size, In.	Diam., In.		Wt. per Ft., Lb.		Nominal Size, In.	Diam., In.		Wt. per Ft., Lb.	
	Out-side.	In-side.	Brass	Cop-per.		Out-side.	In-side.	Brass	Cop-per.
1/8	0.405	0.281	0.246	0.259	3	3.500	3.062	8.314	8.741
1/4	.540	.375	.437	.459	3 1/2	4.000	3.500	10.85	11.41
3/8	.675	.494	.612	.644	4	4.500	4.000	12.29	12.93
1/2	.840	.625	.911	.958	4 1/2	5.000	4.500	13.74	14.44
3/4	1.050	.822	1.235	1.298	5	5.563	5.062	15.40	16.19
1	1.315	1.062	1.740	1.829	6	6.625	6.125	18.44	19.39
1 1/4	1.660	1.368	2.557	2.698	7	7.625	7.062	23.92	25.15
1 1/2	1.900	1.600	3.037	3.193	8	8.625	8.000	30.05	31.60
2	2.375	2.062	4.017	4.224	9	9.625	8.937	36.94	38.84
2 1/2	2.875	2.500	5.830	6.130	10	10.750	10.019	43.91	46.17

Weight per Foot of Seamless Brass Tubes.

(Condensed from Manufacturers' Standard Tables, 1915.)

A. W. G.	2	4	6	8	10	12	14	16	18	20	22	24
Wall.*	0.2576	0.2043	0.1620	0.1285	0.1019	.0808	.0641	.0508	.0403	.0320	.0253	.0201
Diam.†												
1/8	....	....	....	....	....	....	....	0.044	0.039	0.034	0.029	0.024
3/16	....	....	....	....	....	....	0.092	.080	.069	.058	.048	.039
1/4	....	....	....	....	0.175	0.158	.138	.117	.098	.081	.066	.053
5/16	....	....	....	....	.248	.217	.184	.154	.127	.104	.084	.068
3/8	....	....	....	0.376	.322	.275	.231	.191	.156	.127	.103	.083
1/2	....	0.634	.562	.469	.392	.323	.264	.214	.173	.139	.112	.088
5/8	1.10	0.994	.868	.748	.617	.509	.416	.338	.273	.219	.176	.141
3/4	1.47	1.29	1.10	.934	.764	.626	.509	.411	.331	.266	.213	.170
7/8	1.84	1.59	1.34	1.12	.911	.743	.601	.485	.389	.312	.249	.199
1	2.21	1.88	1.57	1.31	1.06	.859	.694	.558	.448	.358	.286	.228
1 1/8	2.59	2.18	1.81	1.49	1.21	.976	.787	.632	.506	.404	.322	.257
1 1/4	2.96	2.47	2.04	1.68	1.35	1.09	.879	.705	.564	.450	.359	.286
1 3/8	3.33	2.77	2.27	1.86	1.50	1.21	.972	.779	.622	.497	.396	.315
1 1/2	3.70	3.06	2.51	2.05	1.65	1.33	1.06	.852	.681	.543	.432	.344
1 3/4	4.45	3.65	2.98	2.42	1.94	1.56	1.25	.999	.797	.635	.506	.402
2	5.19	4.24	3.45	2.79	2.24	1.79	1.44	1.15	.914	.728	.579	.460
2 1/4	5.94	4.84	3.91	3.16	2.53	2.03	1.62	1.29	1.03	.820	.652	.519
2 1/2	6.68	5.43	4.38	3.54	2.83	2.26	1.81	1.44	1.15	.913	.722	.577
2 3/4	7.43	6.02	4.85	3.91	3.12	2.50	1.99	1.59	1.26	1.01	.799	.635
3	8.17	6.61	5.32	4.28	3.42	2.73	2.18	1.73	1.38	1.10	.872	.693
3 1/4	8.92	7.20	5.79	4.65	3.71	2.96	2.36	1.88	1.50	1.19	.946	.751
3 1/2	9.66	7.79	6.26	5.02	4.01	3.20	2.55	2.03	1.61	1.28	1.02	.809
3 3/4	10.4	8.38	6.73	5.39	4.30	3.43	2.73	2.18	1.73	1.37	1.09	.867
4	11.2	8.97	7.19	5.77	4.60	3.66	2.92	2.32	1.85	1.47	1.17	.926
4 1/4	11.9	9.56	7.66	6.14	4.89	3.90	3.10	2.47	1.96	1.56	1.24	.984
4 1/2	12.6	10.2	8.13	6.51	5.19	4.13	3.29	2.62	2.08	1.65	1.31	1.04
4 3/4	13.4	10.7	8.60	6.88	5.48	4.37	3.47	2.76	2.20	1.74	1.39	1.10
5	14.1	11.3	9.07	7.25	5.78	4.60	3.66	2.91	2.31	1.84	1.46	1.16
5 1/4	14.9	11.9	9.54	7.62	6.07	4.83	3.85	3.06	2.43	1.93	...	...
5 1/2	15.6	12.5	10.0	8.00	6.36	5.07	4.03	3.20	2.55	2.02	...	...
5 3/4	16.4	13.1	10.5	8.37	6.66	5.30	4.22	3.35	2.66	2.11	...	...
6	17.1	13.7	10.9	8.74	6.95	5.53	4.40	3.50	2.78	2.21	...	...
6 1/4	17.9	14.3	11.4	9.11	7.25	5.77	4.59	3.65	2.90	...	...	...
6 1/2	18.6	14.9	11.9	9.48	7.54	6.00	4.77	3.79	3.01	...	...	...
6 3/4	19.4	15.5	12.3	9.85	7.84	6.24	4.96	3.94	...	...	...	...
7	20.1	16.1	12.8	10.2	8.13	6.47	5.14	4.09	...	...	...	...
7 1/4	20.8	16.7	13.3	10.6	8.43	6.70	5.33	4.23	...	...	...	...
7 1/2	21.6	17.2	13.8	11.0	8.72	6.94	5.51	4.38	...	...	...	...
7 3/4	22.3	17.8	14.2	11.3	9.02	7.17	5.70	4.53	...	...	...	...
8	23.1	18.4	14.7	11.7	9.31	7.40	5.88	4.67	...	...	...	...
8 1/4	23.8	19.0	15.2	12.1	9.61	7.64	6.07	4.82	...	...	...	...
8 1/2	24.6	19.6	15.6	12.5	9.90	7.87	6.25	4.97	...	...	...	...
8 3/4	25.3	20.2	16.1	12.8	10.2	8.11	6.44	5.12	...	...	...	...
9	26.1	20.8	16.6	13.2	10.5	8.34	6.63	5.26	...	...	...	...
9 1/4	26.8	21.4	17.0	13.6	10.8	8.57	6.81	5.41	...	...	...	...
9 1/2	27.6	22.0	17.5	13.9	11.1	8.81	7.00	5.56	...	...	...	...
9 3/4	28.3	22.6	18.0	14.3	11.4	9.04	7.18	5.70	...	...	...	...
10	29.0	23.2	18.4	14.7	11.7	9.27	7.37	5.85	...	...	...	...

\* Thickness in inches.

† Outside diameter, inches.

Seamless brass tubes are made from 1/8 in. to 1 in. outside diameter, varying by 1/16 in., and from 1 1/8 in. to 10 in. outside diameter, varying by 1/8 in., and in all gages from No. 2 to No. 24 A. W. G. within the limits of the above table. To determine the weight per foot of a tube of a given inside diameter, add to the weights given above the weights given below, under the corresponding gage numbers.

A. W. G.	2	4	6	8	10	12	14	16	18	20	22	24	26
Lb. per ft.	1.54	.966	.607	.382	.240	.151	.095	.060	.038	.024	.015	.009	.0059

For copper tubing add 5% to the weights given above.



**Aluminum Tubing** is made in sizes from 1/4 to 2 in. diam., advancing by 1/8 inch, and from 2 to 6 in. diam., advancing by 1/4 in., in practically all thicknesses from No. 24 to No. 1 B.W.G. Aluminum pipe is made in sizes to correspond with iron-pipe fittings, ranging in diameter from 1/8 to 4 in. Aluminum pipe fittings are made in practically all standard pipe sizes. Details of sizes, weights, strength, etc., of these tubes, pipes, and fittings are given in the pamphlets of the Aluminum Co. of America, Pittsburgh.

**Lead and Tin-Lined Lead Pipe.**  
(United Lead Company, New York, 1915.)

In-side Dia., In.	Letter.	Weight per Ft.	Thickness 1/100 In.	In-side Dia., In.	Letter.	Weight per Ft.	Thickness 1/100 In.	In-side Dia., In.	Letter.	Weight per Ft.	Thickness 1/100 In.
3/8	D	10 oz.	9	5/8	AA	2 3/4 lb.	21	1 1/4	AA	5 3/4 lb.	25
3/8	C	12 oz.	10	5/8	AAA	3 1/2 "	26	1 1/4	AAA	6 3/4 "	28
3/8	B	1 lb.	13	3/4	E	1 "	8	1 1/2	E	3 "	12
3/8	A	1 1/4 "	15	3/4	D	1 1/4 "	9	1 1/2	D	3 1/2 "	14
3/8	AA	1 1/2 "	17	3/4	C	1 3/4 "	13	1 1/2	C	4 1/4 "	16
3/8	AAA	1 3/4 "	20	3/4	Spec'l	2 "	14	1 1/2	B	5 "	19
7/16		13 oz.	10	3/4	B	2 1/4 "	16	1 1/2	A	6 1/2 "	24
7/16		1 lb.	12	3/4	A	3 "	20	1 1/2	AA	7 1/2 "	27
1/2	E	9 oz.	6	3/4	AA	3 1/2 "	23	1 1/2	AAA	8 1/2 "	30
1/2	D	12 "	8	3/4	AAA	4 3/4 "	29	1 3/4	D	4 "	14
1/2	C	1 lb.	11	1	E	1 1/2 "	9	1 3/4	C	5 "	17
1/2	B	1 1/4 "	13	1	D	2 "	12	1 3/4	B	6 "	20
1/2	Spec'l	1 1/2 "	15	1	C	2 1/2 "	14	1 3/4	A	7 "	23
1/2	A	1 3/4 "	17	1	B	3 1/4 "	18	1 3/4	AA	8 1/2 "	27
1/2	AA	2 "	19	1	A	4 "	21	1 3/4	AAA	10 "	31
1/2	Spec'l	2 1/2 "	22	1	AA	4 3/4 "	25	2	D	4 3/4 "	14
1/2	AAA	3 "	26	1	AAA	6 "	30	2	C	6 "	18
5/8	E	3/4 "	7	1 1/4	E	2 "	10	2	B	7 "	21
5/8	D	1 "	9	1 1/4	D	2 1/2 "	12	2	A	8 "	23
5/8	C	1 1/2 "	13	1 1/4	C	3 "	14	2	AA	9 "	26
5/8	B	2 "	16	1 1/4	B	3 3/4 "	17	2	AAA	11 3/4 "	33
5/8	A	2 1/2 "	20	1 1/4	A	4 3/4 "	21				

Weight of lead is taken 0.4106 lb. per cu. in. The safe working strength of lead is about 1/4 the elastic limit, or 225 lb. per sq. in.

**To find the thickness of lead pipe required when the head of water is given.** (Chadwick Lead Works.)

**RULE.**—Multiply the head in feet by size of pipe wanted, expressed decimally, and divide by 750; the quotient will be the thickness required, in one-hundredths of an inch. Thus the thickness of a half-inch pipe for a head of 25 feet will be

$$25 \times 0.50 \div 750 = 0.16 \text{ inch.}$$

**Weight of Lead Pipe Which Should Be Used for a Given Head of Water** (United Lead Co., New York, 1915.)

Head or Number of Feet Fall.	Pressure per sq. inch.	Caliber and Weight per Foot.						
		Letter.	3/8 in.	1/2 in.	5/8 in.	3/4 in.	1 in.	1 1/4 in.
30 ft.	13 lb.	D	10 oz.	3/4 lb.	1 lb.	1 1/4 lb.	2 lb.	2 1/2 lb.
50 ft.	22 lb.	C	12 oz.	1 lb.	1 1/2 lb.	1 3/4 lb.	2 1/2 lb.	3 lb.
75 ft.	32 lb.	B	1 lb.	1 1/4 lb.	2 lb.	2 1/4 lb.	3 1/4 lb.	3 3/4 lb.
100 ft.	44 lb.	A	1 1/4 lb.	1 3/4 lb.	2 1/2 lb.	3 lb.	4 lb.	4 3/4 lb.
150 ft.	65 lb.	AA	1 1/2 lb.	2 lb.	2 3/4 lb.	3 1/2 lb.	4 3/4 lb.	5 3/4 lb.
200 ft.	87 lb.	AAA	1 3/4 lb.	3 lb.	3 1/2 lb.	4 3/4 lb.	6 lb.	6 3/4 lb.



Lead Waste-Pipe.

1 1/2 in., 2 and 3 pounds per foot.	4 in., 5, 6, and 8 pounds per foot.
2 " 3 and 4 pounds per foot.	4 1/2 " 6 and 8 pounds per foot.
3 " 3 1/2, 5, and 6 pounds per foot.	5 " 8, 10, and 12 pounds per foot.
3 1/2 " 4 pounds per foot.	6 " 12 pounds per foot.

Tin-Lined and Lead-Lined Iron Pipe.

(United Lead Co., New York, 1915.)

Size, In.	Wt. per ft., lb.		Size, In.	Wt. per ft., lb.		Size, In.	Wt. per ft., lb.		Size, In.	Wt. per ft., lb. Lead Lined.
	Lead Lined.	Tin Lined.		Lead Lined.	Tin Lined.		Lead Lined.	Tin Lined.		
1/2	1 3/8	1	2	6 1/8	5 1/4	4 1/2	18	16	9	66
3/4	1 5/8	1 3/8	2 1/2	8 1/2	7 1/2	5	21 1/2	26 1/10	10	75
1	2 1/2	2 1/4	3	11 1/2	10 1/6	6	29 3/4	19 1/6	12	88
1 1/4	3 1/2	3	3 1/2	14 1/2	12 8/10	7	36	.....	.....	..
1 1/2	4 3/8	3 3/4	4	15 2/3	14 1/6	8	47	.....	.....	..

Block Tin Pipe and Tubing.

Diam., In.		Thick-ness, in.	Wt. per ft., oz.	Diam., In.		Thick-ness, in.	Wt. per ft., oz.	Diam., In.		Thick-ness, in.	Wt. per ft., oz.
In-side.	Out-side.			In-side.	Out-side.			In-side.	Out-side.		
Tubing.			Pipe.			Pipe.					
1/8	0.25	0.062	1.9	3/8	0.495	0.06	4	5/8	0.800	0.037	10
1/8	.202	.0385	1	3/8	.503	.064	4 1/2	5/8	.831	.103	12
3/16	.292	.053	2	3/8	.515	.07	5	3/4	.901	.076	10
3/16	.331	.072	3	3/8	.539	.082	6	3/4	.928	.089	12
3/16	.367	.09	4	3/8	.561	.093	7	1	1.172	.086	15
1/4	.388	.069	3 1/2	3/8	.584	.104	8	1	1.204	.102	18
Pipe.				1/2	.632	.066	6	1 1/4	1.436	.093	20
				1/2	.670	.085	8	1 1/4	1.471	.110	24
1/4	.400	.075	4	1/2	.707	.103	10	1 1/2	1.746	.123	32
1/4	.433	.091	5	1/2	.741	.120	12	1 1/2	1.802	.151	40
5/16	.444	.066	4	5/8	.735	.055	6	2	2.236	.118	40
7/16	.562	.065	5	5/8	.768	.071	8	2	2.280	.140	48

Weight of tin taken as 0.2652 lb. per cubic inch.

Weight Per Foot of Brass- and Copper-Lined Iron Pipe.

(United Lead Co., New York, 1915.)

Size, In.	Wt., lb. Brass-Lined	Wt., lb. Copper-Lined	Size, In.	Wt., lb. Brass-Lined	Wt., lb. Copper-Lined	Size, In.	Wt., lb. Brass-Lined	Wt., lb. Copper-Lined	Size, In.	Wt., lb. Brass-Lined	Wt., lb. Copper-Lined
1 1/2	1	1	1 1/4	2 2/3	2 2/3	2 1/2	6 7/10	6 3/4	5	19 1/2	19 3/4
3/4	1 3/8	1 3/8	1 1/2	3 1/4	3 1/4	3	8 3/4	8 8/10	6	25 1/4	25 6/10
1	2	2	2	4 1/3	4 3/8	4	12 6/10	12 7/10	8	38	38 1/2

**Lead-Lined** pipe is particularly adapted for use in contact with acids, mine water, salt water, or any liquid which has a corrosive action on iron pipe.

**Lead Covered** iron pipe for use in bleacheries, etc., where steam passes through the pipe and the exterior is in contact with acid or corrosive solutions is made in commercial sizes of  $\frac{1}{2}$ ,  $\frac{3}{4}$ , 1,  $1\frac{1}{4}$ ,  $1\frac{1}{2}$ , 2 and 3 inches.

**Brass and Copper Pipes, Lined with Tin or Lead**, are made in commercial sizes of  $\frac{1}{2}$ ,  $\frac{3}{4}$ , 1,  $1\frac{1}{4}$ ,  $1\frac{1}{2}$ , and 2 inches.

**Sheet Lead** is rolled to any weight per sq. ft. from 1 to 7 lb. in any width up to 11 ft. 6 in., and from 8 lb. up, 12 ft. wide. A square foot of rolled sheet lead 1 in. thick weighs approximately 59  $\frac{1}{2}$  lb.

### Approximate Weight of Sheet Zinc.

(Aluminum Co. of America, 1914.)

Zinc No.	Thickness, Inches.	Wt. per Sq. Ft., Lb.	Zinc No.	Thickness, Inches.	Wt. per Sq. Ft., Lb.	Zinc No.	Thickness, Inches.	Wt. per Sq. Ft., Lb.	Zinc No.	Thickness, Inches.	Wt. per Sq. Ft., Lb.
1	0.002	0.075	8	0.016	0.60	15	0.040	1.50	22	0.090	3.37
2	.004	.15	9	.018	.67	16	.045	1.68	23	.100	3.75
3	.006	.225	10	.020	.75	17	.050	1.87	24	.125	4.70
4	.008	.30	11	.024	.90	18	.055	2.06	25	.250	9.40
5	.010	.37	12	.028	1.05	19	.060	2.25	26	.375	14.10
6	.012	.45	13	.032	1.20	20	.070	2.62	27	.500	18.80
7	.014	.52	14	.034	1.35	21	.080	3.00	28	1.000	37.60

### Weight of Sheet or Bar Brass.

(Compiled from Manufacturers' Standard Tables.)

Thickness, Side, or Dia.	Sheets, Lb. per Sq. Ft.	Sq. Bar, 1 Ft. Long.	Round Bar, 1 Ft. Long.	Thickness, Side, or Dia.	Sheets, Lb. per Sq. Ft.	Sq. Bar, 1 Ft. Long.	Round Bar, 1 Ft. Long.	Thickness, Side, or Dia.	Sheets, Lb. per Sq. Ft.	Sq. Bar, 1 Ft. Long.	Round Bar, 1 Ft. Long.
In.		Lb.	Lb.	In.		Lb.	Lb.	In.		Lb.	Lb.
$\frac{1}{16}$	2.77	0.014	0.011	$\frac{3}{4}$	33.21	2.075	1.630	$\frac{17}{16}$	63.66	7.623	5.987
$\frac{1}{8}$	5.54	.058	.045	$\frac{13}{16}$	35.98	2.435	1.913	$\frac{11}{2}$	66.42	8.300	6.519
$\frac{3}{16}$	8.30	.130	.102	$\frac{7}{8}$	38.75	2.824	2.218	$\frac{19}{16}$	69.19	9.006	7.073
$\frac{1}{4}$	11.07	.231	.181	$\frac{15}{16}$	41.51	3.242	2.546	$\frac{15}{8}$	71.96	9.741	7.651
$\frac{5}{16}$	13.84	.360	.283	1	44.28	3.689	2.897	$\frac{11}{16}$	74.73	10.50	8.250
$\frac{3}{8}$	16.61	.519	.407	$\frac{11}{16}$	47.05	4.164	3.271	$\frac{13}{4}$	77.49	11.30	8.873
$\frac{7}{16}$	19.37	.706	.555	$\frac{11}{8}$	49.82	4.669	3.667	$\frac{13}{16}$	80.26	12.12	9.518
$\frac{1}{2}$	22.14	.922	.724	$\frac{13}{16}$	52.59	5.202	4.086	$\frac{17}{8}$	83.03	12.97	10.19
$\frac{9}{16}$	24.91	1.167	.917	$\frac{11}{4}$	55.35	5.764	4.527	$\frac{15}{16}$	85.80	13.85	10.88
$\frac{5}{8}$	27.68	1.441	1.132	$\frac{15}{16}$	58.12	6.355	4.991	2	88.56	14.76	11.59
$\frac{11}{16}$	30.44	1.744	1.369	$\frac{13}{8}$	60.89	6.974	5.478				



**Weight of Aluminum Plates. (Brown & Sharpe Gage.)**  
(Aluminum Co. of America, 1914.)

Gage.	Thick- ness, In.	Wgt., Lb.	Gage.	Thick- ness, In.	Wgt., Lb.	Gage.	Thick- ness, In.	Wgt., Lb.
0000	0.46000	6.406	12	0.080808	1.126	27	0.014195	0.1976
000	.40964	5.704	13	.071961	1.002	28	.012641	.1760
00	.36480	5.080	14	.064084	.8924	29	.011257	.1567
0	.32486	4.524	15	.057068	.7946	30	.010025	.1396
1	.28930	4.029	16	.050820	.7078	31	.008928	.1244
2	.25763	3.588	17	.045257	.6302	32	.007950	.1107
3	.22942	3.195	18	.040303	.5612	33	.007080	.09854
4	.20431	2.845	19	.035890	.4998	34	.006304	.08778
5	.18194	2.534	20	.031961	.4450	35	.005614	.07817
6	.16202	2.256	21	.028462	.3964	36	.005000	.06962
7	.14428	2.009	22	.025347	.3530	37	.004453	.06201
8	.12849	1.789	23	.022571	.3143	38	.003965	.05521
9	.11443	1.594	24	.020100	.2798	39	.003531	.04917
10	.10189	1.418	25	.017900	.2492	40	.003144	.04378
11	.090742	1.264	26	.015940	.2219			

**Weight of Sheet or Bar Aluminum (Sp. Gr. 2.68).**  
(Aluminum Co. of America, 1914.)

Thickness, Side, or Dia.	Sheets, Lb. per Sq. Ft.		Sq. Bars, 1 Ft. Long.		Round Bars, 1 Ft. Long.		Thickness, Side, or Dia.	Sheets, Lb. per Sq. Ft.		Sq. Bars, 1 Ft. Long.		Round Bars, 1 Ft. Long.	
	In.	Lb.	Lb.	Lb.	In.	Lb.		Lb.	In.	Lb.	Lb.	Lb.	
1/16	0.869	0.004	0.003	3/4	10.436	0.652	0.516	17/16	20.002	2.396	1.882		
1/8	1.739	.018	.014	13/16	11.306	.766	.601	1 1/2	20.872	2.609	2.049		
3/16	2.609	.041	.032	7/8	12.175	.888	.697	1 9/16	21.741	2.831	2.223		
1/4	3.479	.072	.057	15/16	13.045	1.019	.800	1 5/8	22.611	3.062	2.405		
5/16	4.348	.114	.089	1	13.915	1.159	.911	1 11/16	23.481	3.302	2.593		
3/8	5.218	.163	.128	1 1/16	14.784	1.309	1.028	1 3/4	24.350	3.550	2.789		
7/16	6.088	.222	.174	1 1/8	15.654	1.467	1.152	1 13/16	25.250	3.810	2.992		
1/2	6.958	.290	.227	1 3/16	16.524	1.635	1.284	1 7/8	26.090	4.075	3.202		
9/16	7.827	.367	.288	1 1/4	17.394	1.812	1.423	1 15/16	26.960	4.352	3.417		
5/8	8.697	.453	.356	1 5/8	18.263	1.997	1.569	2	27.829	4.638	3.642		
11/16	9.567	.548	.430	1 3/8	19.133	2.192	1.722						

For further particulars regarding aluminum see pp. 380-383; 396-401.

**Weight Per Foot of Copper Rods, Pounds.**  
(From tables of manufacturers, 1914.)

In.	Round.	Square.	In.	Round.	Square.	In.	Round.	Square.
1/8	0.04735	0.06028	1 1/8	3.835	4.882	2 1/8	13.68	17.41
1/4	.1894	.2411	1 1/4	4.735	6.028	2 1/4	15.34	19.53
3/8	.4261	.5424	1 3/8	5.729	7.293	2 3/8	17.09	21.76
1/2	.7576	.9644	1 1/2	6.818	8.679	2 1/2	18.94	24.11
5/8	1.184	1.507	1 5/8	8.002	10.19	2 5/8	20.88	26.58
3/4	1.705	2.170	1 3/4	9.281	11.81	2 3/4	22.92	29.18
7/8	2.320	2.953	1 7/8	10.65	13.56	2 7/8	25.05	31.89
1	3.030	3.857	2	12.12	15.53	3	27.27	34.71

For weight of octagon rod, multiply the weight of round rod by 1.084.  
For weight of hexagon rod, multiply the weight of round rod by 1.12.



SCREW THREADS.

Sellers or U. S. Standard.

The system of screw threads devised by William Sellers and recommended for adoption by a committee of the Franklin Institute in 1864 is now in general use in the United States and is known as the U. S. standard. The angle of the thread is 60 deg. The thread is flattened at the top, the width of flat being one-eighth the pitch. The bottom of the thread is filled in, the width of flat at the bottom also being one-eighth the pitch. The wearing surface of the thread is thus three-quarters the pitch.

Diam. at root of thread = diam. of bolt - (1.299 ÷ No. of threads per in.).

For a sharp V thread, with an angle of 60 deg. the formula is Diam. at root of thread = diam. of bolt - (1.733 ÷ No. of threads per in.).

The rules for dimensioning nuts and heads given in the Franklin Institute report are:

Let  $d$  = diameter of bolt,  $D$  = short diameter of rough nut or head, (Continued on page 232.)

Dimensions of Screw-Threads, Sellers or U. S. Standard.

BOLTS AND THREADS.						NUTS AND BOLT HEADS.			Thickness, Nut.	Thickness, Head.
Diam. of Bolt.	Threads per Inch.	Diam. of Root of Thread.	Width of Flat.	Area of Bolt Body in Sq. Inches.	Area of Root of Thread in Square In.	Short Diam., Hex. and Sq.	Long Diam., Hexagon.	Long Diam., Square		
In.		In.	In.			In.	In.	In.	In.	In.
1/4	20	0.185	0.0062	0.049	0.027	1/2	0.578	0.707	1/4	1/4
5/16	18	.240	.0069	.077	.045	19/32	.686	.840	5/16	19/64
3/8	16	.294	.0078	.110	.068	11/16	.794	.972	3/8	11/32
7/16	14	.345	.0089	.150	.093	25/32	.902	1.105	7/16	25/64
1/2	13	.400	.0096	.196	.126	7/8	1.011	1.237	1/2	7/16
9/16	12	.454	.0104	.249	.162	31/32	1.119	1.370	9/16	31/64
5/8	11	.507	.0113	.307	.202	1 1/16	1.227	1.502	5/8	17/32
3/4	10	.620	.0125	.442	.302	1 1/4	1.444	1.768	3/4	5/8
7/8	9	.731	.0139	.601	.420	1 7/16	1.660	2.033	7/8	23/32
1	8	.837	.0156	.785	.550	1 5/8	1.877	2.298	1	13/16
1 1/8	7	.939	.0178	.994	.694	1 13/16	2.093	2.563	1 1/8	29/32
1 1/4	7	1.065	.0178	1.227	.891	2	2.310	2.828	1 1/4	1
1 3/8	6	1.160	.0208	1.485	1.057	2 3/16	2.527	3.093	1 3/8	1 3/32
1 1/2	6	1.284	.0208	1.767	1.295	2 3/8	2.743	3.358	1 1/2	1 3/16
1 5/8	5 1/2	1.389	.0227	2.074	1.515	2 9/16	2.960	3.623	1 5/8	1 9/32
1 3/4	5	1.491	.0250	2.405	1.746	2 3/4	3.176	3.889	1 3/4	1 3/8
1 7/8	5	1.616	.0250	2.761	2.051	2 15/16	3.393	4.154	1 7/8	1 15/32
2	4 1/2	1.712	.0278	3.142	2.302	3 1/8	3.609	4.419	2	1 9/16
2 1/4	4 1/2	1.962	.0278	3.976	3.023	3 1/2	4.043	4.949	2 1/4	1 3/4
2 1/2	4	2.176	.0312	4.909	3.719	3 7/8	4.476	5.479	2 1/2	1 15/16
2 3/4	4	2.426	.0312	5.940	4.622	4 1/4	4.909	6.010	2 3/4	2 1/8
3	3 1/2	2.629	.0357	7.069	5.428	4 5/8	5.342	6.540	3	2 5/16
3 1/4	3 1/2	2.879	.0357	8.296	6.510	5	5.775	7.070	3 1/4	2 1/2
3 1/2	3 1/4	3.100	.0384	9.621	7.548	5 3/8	6.208	7.600	3 1/2	2 11/16
3 3/4	3	3.317	.0417	11.045	8.641	5 3/4	6.641	8.131	3 3/4	2 7/8
4	3	3.567	.0417	12.566	9.993	6 1/8	7.074	8.661	4	3 1/16
4 1/4	2 7/8	3.798	.0435	14.186	11.328	6 1/2	7.508	9.191	4 1/4	3 1/4
4 1/2	2 3/4	4.028	.0454	15.904	12.743	6 7/8	7.941	9.721	4 1/2	3 7/16
4 3/4	2 5/8	4.256	.0476	17.721	14.250	7 1/4	8.374	10.252	4 3/4	3 5/8
5	2 1/2	4.480	.0500	19.635	15.763	7 5/8	8.807	10.782	5	3 13/16
5 1/4	2 1/2	4.730	.0500	21.648	17.572	8	9.240	11.312	5 1/4	4
5 1/2	2 3/8	4.953	.0526	23.758	19.267	8 3/8	9.673	11.842	5 1/2	4 2/16
5 3/4	2 3/8	5.203	.0526	25.967	21.262	8 3/4	10.106	12.373	5 3/4	4 3/8
6	2 1/4	5.423	.0555	28.274	23.098	9 1/8	10.539	12.903	6	4 9/16

$D_1$  = short diameter of finished nut or head;  $T$  = thickness of rough nut;  $T_1$  = thickness of finished nut;  $t$  = thickness of rough head,  $t_1$  thickness of finished head;  $D = 1.5 d + 1/8$ ;  $D_1 = 1.5 d + 1/16$ ;  $T = d$ ;  $T_1 = d - 1/16$ ;  $t = 1/2 D$ ;  $t_1 = 1/2 d - 1/16$ .

The dimensions given by the above formulæ for nuts and heads are not generally accepted by the makers of nuts and bolts. The general practice is to make the rough and finished nuts of the same dimensions, otherwise different wrenches would be required for the same size of nut. The dimensions of nuts and bolt heads given in the above table are those adopted by the Upson Nut Co., Hoopes and Townsend, and the U. S. Navy, and agree with the formulæ  $D = 1.5 d + 1/8$ ,  $T = T_1 = d$ ,  $t = t_1 = 1/2 D$ .

### Screw-Threads, Whitworth (English) Standard.

Diam.	Pitch.	Diam.	Pitch.	Diam.	Pitch.	Diam.	Pitch.	Diam.	Pitch.
1/4	20	5/8	11	1	8	1 3/4	5	3	3 1/2
5/16	18	11/16	11	1 1/8	7	1 7/8	4 1/2	3 1/4	3 1/4
3/8	16	3/4	10	1 1/4	7	2	4 1/2	3 1/2	3 1/4
7/16	14	13/16	10	1 3/8	6	2 1/4	4	3 3/4	3
1/2	12	7/8	9	1 1/2	6	2 1/2	4	4	3
9/16	:2	15/16	9	1 5/8	5	2 3/4	3 1/2		

In the Whitworth or English system the angle of the thread is 55 degrees, and the point and root of the thread are rounded to a radius of  $0.1373 \times$  pitch. The depth of the thread is  $0.6403 \times$  pitch.

### International Standard Thread (Metric System).

The form of thread is the same as the U. S. Standard.  $P$  = pitch, =  $1 -$  No. of threads per millimeter.

Diam., mm.	6	7	8	9	10	11	12	14	16	18	20	22	24	27
Pitch, mm.	1.0	1.0	1.25	1.25	1.5	1.5	1.75	2.	2.	2.5	2.5	2.5	3.	3.
Diam., mm.	30	33	36	39	42	45	48	52	56	60	64	68	72	76
Pitch, mm.	3.5	3.5	4.	4.	4.5	4.5	5.	5.	5.5	5.5	6.	6.	6.5	6.5

### British Association Standard Thread.

The angle between the threads is  $47 \frac{1}{2}^\circ$ . The depth of the thread is  $0.6 \times$  the pitch. The tops and bottoms of the threads are rounded with a radius of  $2/11$  of the pitch.

Number	0	1	2	4	5	5	6
Diameter, mm.	6.0	5.3	4.7	4.1	3.64	3.2	2.8
Pitch, mm.	1.00	0.90	0.81	0.73	0.66	0.59	0.53
Number	7	8	9	10	12	14	19
Diameter, mm.	2.5	2.2	1.9	1.7	1.3	1.0	0.79
Pitch, mm.	0.48	0.43	0.39	0.35	0.28	0.23	0.19

### Limit Gages for Iron for Screw-Threads.

In adopting the Sellers, or Franklin Institute, or United States Standard, as it is variously called, a difficulty arose from the fact that it is the habit of iron manufacturers to make iron over-size, and as there are no over-size screws in the Sellers system, if iron is too large it is necessary to cut it away with the dies. So great is this difficulty, that the practice of making taps and dies over-size has become very general. If the Sellers system is adopted it is essential that iron should be obtained of the correct size, or very nearly so. Of course no high degree of precision is possible in rolling iron, and when exact sizes were demanded, the question arose how much allowable variation there should be from the true size. It was proposed to make limit-gages for inspecting iron with two openings, one larger and the other smaller than the standard size, and

then specify that the iron should enter the large end and not enter the small one. The following table of dimensions for the limit-gages was adopted by the Master Car-Builders' Association in 1883.

Size of Iron, In.	Large End of Gage.	Small End of Gage.	Difference.	Size of Iron, In.	Large End of Gage.	Small End of Gage.	Difference.	Size of Iron, In.	Large End of Gage.	Small End of Gage.	Difference.
1/4	0.2550	0.2450	0.010	5/8	0.6330	0.6170	0.016	13/8	1.3860	1.3640	0.022
5/16	0.3180	0.3070	0.011	3/4	0.7585	0.7415	0.017	11/2	1.5115	1.4885	0.023
3/8	0.3810	0.3690	0.012	7/8	0.8840	0.8660	0.018	15/8	1.6370	1.6130	0.024
7/16	0.4440	0.4310	0.013		1.0095	0.9905	0.019	13/4	1.7625	1.7375	0.025
1/2	0.5070	0.4930	0.014	11/8	1.1350	1.1150	0.020	17/8	1.8880	1.8620	0.026
9/16	0.5700	0.5550	0.015	11/4	1.2605	1.2395	0.021				

Caliper gages with the above dimensions, and standard reference gages for testing them, are made by the Pratt & Whitney Co., Hartford.

**Automobile Screws and Nuts.**—The Society of Automobile Engineers (1912) adopted standard specifications for hexagon head screws, castle and plain nuts known as the A.L.A.M. standard. Material to be steel, elastic limit not less than 60,000 lbs. per sq. in., tensile strength not less than 100,000 lbs. per sq. in. U. S. Standard thread is used, the threaded portion of screws being 1 1/2 times the diameter. The castle nut has a boss on the upper surface with six slots for a locking pin through the bolt.

**Standard Automobile Screws, Castle and Plain Nuts.**

All dimensions in inches. *P* = pitch, or number of threads per inch. *d* = diam. of cotter pin.  $P \div 8$  = flat top of thread. The body diam. of screws is 0.001 in. less than nominal diam., with a plus tolerance of zero and a minus tolerance of 0.002 in. The top shall be between 0.003 in. and 0.003 in. large.

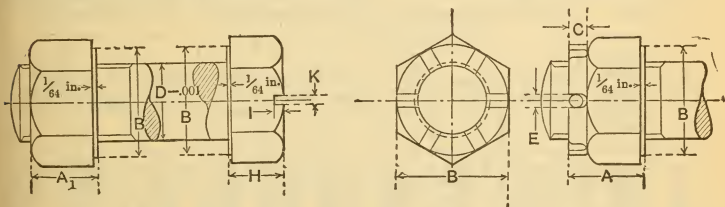

D	P	B	A <sub>1</sub>	H	K	I	A	C	E	d
1/4	28	7/16	7/32	3/16	1/16	3/32	9/32	.....	5/64	1/16
5/16	24	1/2	17/64	15/64	1/16	7/64	21/64	3/32	5/64	1/16
3/8	24	9/16	21/64	9/32	3/32	1/8	13/32	1/8	1/8	3/32
7/16	20	5/8	3/8	21/64	3/32	1/8	29/64	1/8	1/8	3/32
1/2	20	3/4	7/16	3/8	3/32	1/8	9/16	3/16	1/8	3/32
9/16	18	7/8	31/64	27/64	3/32	1/8	39/64	3/16	5/32	1/8
5/8	18	15/16	35/64	15/32	3/32	1/8	23/32	1/4	5/32	1/8
11/16	16	1	19/32	33/64	3/32	1/8	49/64	1/4	5/32	1/8
3/4	16	1 1/16	21/32	9/16	3/32	1/8	13/16	1/4	5/32	1/8
7/8	14	1 1/4	49/64	21/32	3/32	1/8	29/32	1/4	5/32	1/8
1	14	1 7/16	7/8	3/4	3/32	1/8	1	1/4	5/32	1/8
1 1/8	12	1 5/8	63/64	27/32	5/32	7/32	1 5/32	5/16	7/32	11/64
1 1/4	12	1 13/16	1 3/32	15/16	5/32	7/32	1 1/4	5/16	7/32	11/64
1 3/8	12	2	1 13/64	1 1/32	3/16	1/4	1 13/32	3/8	1/4	13/64
1 1/2	12	2 3/16	1 5/16	1 1/8	3/16	1/4	1 1/2	3/8	1/4	13/64

### The Acme Screw Thread.

The Acme Thread is an adaptation of the commonly used style of worm thread and is intended to take the place of the square thread. It is a little shallower than the worm thread, but the same depth as the square thread and much stronger than the latter. The angle of the thread is 29°.

The various parts of the Acme Thread are obtained as follows:

Width of point of tool for screw or tap thread =  
(0.3707 ÷ No. of Threads per in.) - 0.0052.

Width of screw or nut thread = 0.3707 ÷ No. of Threads per in.

Diam. of Tap = Diam. of Screw + 0.020.

Diam. of Tap or } = Diam. of Screw -  $\frac{1}{\text{No. of Threads per in.}}$  + 0.020.  
Screw at Root }

Depth of Thread =  $\left\{ 1 \div (2 \times \text{No. of Threads per in.}) \right\} + 0.010$ .

The angle of the thread is 29 deg.

### MACHINE SCREWS.—A.S.M.E. Standard.

The American Society of Mechanical Engineers (1907) received a report on standard machine screws from its committee on that subject. The included angle of the thread is 60 degrees and a flat is made at the top and bottom of the thread of one-eighth of the pitch for the basic diameter. A uniform increment of 0.013 inch exists between all sizes from 0 to 10 and 0.026 inch in the remaining sizes. The pitches are a function of the diameter as expressed by the formula

$$\text{Threads per inch} = \frac{6.5}{D + 0.02}$$

The minimum tap conforms to the basic standard in all respects except diameter. The difference between the minimum tap and the maximum screw provides an allowance for error in pitch and for wear of the tap in service.

#### A. S. M. E. Standard Machine Screws.

(Corbin Screw Corporation.)

Size.		Outside Diameters.			Pitch Diameters.			Root Diameters.		
No.	Out. Dia. and Thds. per In.	Minimum.	Maximum.	Difference.	Minimum.	Maximum.	Difference.	Minimum.	Maximum.	Difference.
0	.060-80	.0572	.060	.0028	.0505	.0519	.0014	.0410	.0438	.0028
1	.073-72	.070	.073	.003	.0625	.064	.0015	.052	.055	.0030
2	.086-64	.0828	.086	.0032	.0743	.0759	.0016	.0624	.0657	.0033
3	.099-56	.0955	.099	.0035	.0857	.0874	.0017	.0721	.0758	.0037
4	.112-48	.1082	.112	.0038	.0966	.0985	.0019	.0807	.0849	.0042
5	.125-44	.1210	.125	.0040	.1082	.1102	.0020	.0910	.0955	.0045
6	.138-40	.1338	.138	.0042	.1197	.1218	.0021	.1007	.1055	.0048
7	.151-36	.1466	.151	.0044	.1308	.1330	.0022	.1097	.1149	.0052
8	.164-36	.1596	.164	.0044	.1438	.146	.0022	.1227	.1279	.0052
9	.177-32	.1723	.177	.0047	.1544	.1567	.0023	.1307	.1364	.0057
10	.190-30	.1852	.190	.0048	.166	.1684	.0024	.1407	.1467	.0060
12	.216-28	.2111	.216	.0049	.1904	.1928	.0024	.1633	.1696	.0063
14	.242-24	.2368	.242	.0052	.2123	.2149	.0026	.1808	.1879	.0071
16	.268-22	.2626	.268	.0054	.2358	.2385	.0027	.2014	.209	.0076
18	.294-20	.2884	.294	.0056	.2587	.2615	.0028	.2208	.229	.0082
20	.320-20	.3144	.320	.0056	.2847	.2875	.0028	.2468	.255	.0082
22	.346-18	.3402	.346	.0058	.3070	.3099	.0029	.2649	.2738	.0089
24	.372-16	.366	.372	.0060	.3284	.3314	.0030	.281	.2908	.0098
26	.398-16	.392	.398	.0060	.3544	.3574	.0030	.307	.3168	.0098
28	.424-14	.4178	.424	.0062	.3745	.3776	.0031	.3204	.3312	.0108
30	.450-14	.4438	.450	.0062	.4005	.4036	.0031	.3464	.3572	.0108



**A. S. M. E. Special Screws.**  
(All Dimensions in Inches.)

Old No.	New. Outside Diam. and Threads per In.	Outside Diameters.			Pitch Diameters.			Root Diameters.		
		Minimum.	Maximum.	Difference.	Minimum.	Maximum.	Difference.	Minimum.	Maximum.	Difference.
1	0.073-64	0.0698	0.073	0.0032	0.0613	0.0629	0.0016	0.0494	0.0527	0.0033
2	.086-56	.0825	.086	.0035	.0727	.0744	.0017	.0591	.0628	.0037
3	.099-48	.0952	.099	.0038	.0836	.0855	.0019	.0677	.0719	.0042
4	.112-40	.1078	.112	.0042	.0937	.0958	.0021	.0747	.0795	.0048
	36	.1076	.112	.0044	.0918	.0940	.0022	.0707	.0759	.0052
5	.125-40	.1208	.125	.0042	.1067	.1088	.0021	.0877	.0925	.0048
	36	.1206	.125	.0044	.1048	.1070	.0022	.0837	.0889	.0052
6	.138-36	.1336	.138	.0044	.1178	.1200	.0022	.0967	.1019	.0052
	32	.1333	.138	.0047	.1154	.1177	.0023	.0917	.0974	.0057
7	.151-32	.1463	.151	.0047	.1284	.1307	.0023	.1047	.1104	.0057
	30	.1462	.151	.0048	.1270	.1294	.0024	.1017	.1077	.0060
8	.164-32	.1593	.164	.0047	.1414	.1437	.0023	.1177	.1234	.0057
	30	.1592	.164	.0048	.1400	.1424	.0024	.1147	.1207	.0060
9	.177-30	.1722	.177	.0048	.1529	.1553	.0024	.1277	.1337	.0060
	24	.1718	.177	.0052	.1473	.1499	.0026	.1158	.1229	.0071
10	.190-32	.1853	.190	.0047	.1674	.1697	.0023	.1437	.1494	.0057
	24	.1848	.190	.0052	.1603	.1629	.0026	.1288	.1359	.0071
12	.216-24	.2108	.216	.0052	.1863	.1889	.0026	.1548	.1619	.0071
14	.242-20	.2364	.242	.0056	.2067	.2095	.0028	.1688	.1770	.0082
16	.268-20	.2624	.268	.0056	.2327	.2355	.0028	.1948	.2030	.0082
18	.294-18	.2882	.294	.0058	.2550	.2579	.0029	.2129	.2218	.0089
20	.320-18	.3142	.320	.0058	.2810	.2839	.0029	.2389	.2478	.0089
22	.346-16	.3400	.346	.0060	.3024	.3054	.0030	.2550	.2648	.0098
24	.372-18	.3662	.372	.0058	.3330	.3359	.0029	.2909	.2998	.0089
26	.398-14	.3918	.398	.0062	.3485	.3516	.0031	.2944	.3052	.0108
28	.424-16	.4180	.424	.0060	.3804	.3834	.0030	.3330	.3428	.0098
30	.450-16	.4440	.450	.0060	.4064	.4094	.0030	.3590	.3688	.0098

**A. S. M. E. Standard Taps.**  
(Corbin Screw Corporation.)

No.	Size. Out. Dia. and Thds. per In.	Outside Diameters.			Pitch Diameters.			Root Diameters.			Tap Drill Diameters.
		Minimum, In.	Maximum, In.	Difference.	Minimum, In.	Maximum, In.	Difference.	Minimum, In.	Maximum, In.	Difference.	
0	0.060-80	0.0609	0.0632	0.0023	0.0528	0.0538	0.0010	0.0447	0.0466	0.0019	0.0465
1	.073-72	.0740	.0765	.0025	.0650	.0660	.0010	.0560	.0580	.0020	.0595
2	.086-64	.0871	.0898	.0027	.0770	.0781	.0011	.0668	.0689	.0021	.0700
3	.099-56	.1002	.1033	.0031	.0886	.0897	.0011	.0770	.0793	.0023	.0785
4	.112-48	.1133	.1168	.0035	.0998	.1010	.0012	.0862	.0887	.0025	.0890
5	.125-44	.1263	.1301	.0038	.1116	.1129	.0013	.0968	.0995	.0027	.0995
6	.138-40	.1394	.1435	.0041	.1232	.1246	.0014	.1069	.1097	.0028	.1100
7	.151-36	.1525	.1569	.0044	.1345	.1359	.0014	.1164	.1193	.0029	.1200
8	.164-36	.1655	.1699	.0044	.1475	.1489	.0014	.1294	.1323	.0029	.1360
9	.177-32	.1786	.1835	.0049	.1583	.1598	.0015	.1380	.1411	.0031	.1405
10	.190-30	.1916	.1968	.0052	.1700	.1716	.0016	.1483	.1515	.0032	.1520
12	.216-28	.2176	.2232	.0056	.1944	.1961	.0017	.1712	.1745	.0033	.1730
14	.242-24	.2438	.2500	.0062	.2167	.2184	.0017	.1896	.1931	.0035	.1935
16	.268-22	.2698	.2765	.0067	.2403	.2421	.0018	.2108	.2144	.0036	.2130
18	.294-20	.2959	.3031	.0072	.2634	.2652	.0018	.2309	.2346	.0037	.2340
20	.320-20	.3219	.3291	.0072	.2894	.2912	.0018	.2569	.2606	.0037	.2610
22	.346-18	.3479	.3559	.0080	.3118	.3138	.0020	.2757	.2796	.0039	.2810
24	.372-16	.374	.3828	.0088	.3334	.3354	.0020	.2928	.2968	.0040	.2968
26	.398-16	.400	.4088	.0088	.3594	.3614	.0020	.3188	.3228	.0040	.3230
28	.424-14	.4261	.4359	.0098	.3797	.3818	.0021	.3333	.3374	.0041	.3390
30	.450-14	.4521	.4619	.0098	.4057	.4078	.0021	.3593	.3634	.0041	.3680

**A. S. M. E. Special Taps.**  
(Corbin Screw Corporation.)

No.	Size. Out. Dia. and Thds. per In.	Outside Diameters.			Pitch Diameters.			Root Diameters.			Tap Drill Diameters.
		Min., In.	Max., In.	Dif- fer- ence.	Min., In.	Max., In.	Dif- fer- ence.	Min., In.	Max., In.	Dif- fer- ence.	
1	0.073-64	0.0741	0.0768	0.0027	0.0640	0.0651	0.0011	0.0538	0.0559	0.0021	0.0550
2	.086-56	.0872	.0903	.0031	.0756	.0767	.0011	.0640	.0663	.0023	.0670
3	.099-48	.1003	.1038	.0035	.0868	.0880	.0012	.0732	.0757	.0025	.0760
4	.112-40	.1134	.1175	.0041	.0972	.0986	.0014	.0809	.0837	.0028	.0820
	36	.1135	.1179	.0044	.0955	.0969	.0014	.0774	.0803	.0029	.0810
5	.125-40	.1264	.1305	.0041	.1102	.1116	.0014	.0939	.0967	.0028	.0980
	36	.1265	.1309	.0044	.1085	.1099	.0014	.0904	.0933	.0029	.0935
6	.138-36	.1395	.1459	.0064	.1215	.1229	.0014	.1034	.1063	.0029	.1065
	32	.1396	.1445	.0049	.1193	.1208	.0015	.0990	.1021	.0031	.1015
7	.151-32	.1526	.1575	.0049	.1323	.1338	.0015	.1120	.1151	.0031	.1160
	30	.1526	.1578	.0052	.1310	.1326	.0016	.1093	.1125	.0032	.1130
8	.164-32	.1656	.1705	.0049	.1453	.1468	.0015	.1250	.1281	.0031	.1285
	30	.1656	.1708	.0052	.1440	.1456	.0016	.1223	.1255	.0032	.1285
9	.177-30	.1786	.1838	.0052	.1569	.1585	.0016	.1353	.1385	.0032	.1405
	24	.1788	.1850	.0062	.1517	.1534	.0017	.1247	.1282	.0035	.1285
10	.190-32	.1916	.1965	.0049	.1713	.1728	.0015	.1510	.1541	.0031	.1540
	24	.1918	.1980	.0062	.1647	.1664	.0017	.1377	.1412	.0035	.1405
12	.216-24	.2178	.2240	.0062	.1907	.1924	.0017	.1637	.1672	.0035	.1660
14	.242-20	.2439	.2511	.0072	.2114	.2132	.0018	.1789	.1826	.0037	.1820
16	.268-20	.2699	.2771	.0072	.2374	.2392	.0018	.2049	.2086	.0037	.2090
18	.294-18	.2959	.3039	.0080	.2598	.2618	.0020	.2237	.2276	.0039	.2280
20	.320-18	.3219	.3299	.0080	.2858	.2878	.0020	.2497	.2536	.0039	.2570
22	.346-16	.3480	.3568	.0088	.3074	.3094	.0020	.2668	.2708	.0040	.2720
24	.372-18	.3739	.3819	.0080	.3378	.3398	.0020	.3017	.3056	.0039	.3125
26	.398-14	.4001	.4099	.0098	.3537	.3558	.0021	.3073	.3114	.0041	.3125
28	.424-16	.4260	.4348	.0088	.3854	.3874	.0020	.3448	.3488	.0040	.3480
30	.450-16	.4520	.4608	.0088	.4114	.4134	.0020	.3708	.3748	.0040	.3770

**Wood Screws.**

Two systems of wood screw threads are in common use, that of the American Screw Co. and that of the Asa I. Cook Co. They are alike as to diameters but differ in the number of threads per inch.

No.	Diam., In.	Threads per In.		No.	Diam., In.	Threads per In.		No.	Diam., In.	Threads per In.	
		Amer. Screw Co.	Asa M. Cook Co.			Amer. Screw Co.	Asa M. Cook Co.			Amer. Screw Co.	Asa M. Cook Co.
0	0.058	32	30	11	0.203	12	12.5	22	0.347	7	7.5
1	.071	28	28	12	.216	11	12	23	.361	7	.....
2	.084	26	26	13	.229	11	11	24	.374	7	7
3	.097	24	24	14	.242	10	10	25	.387	7	.....
4	.110	22	22	15	.255	10	9.5	26	.400	6	6.5
5	.124	20	20	16	.268	9	9	27	.413	6	.....
6	.137	18	18	17	.282	9	8.5	28	.426	6	6.5
7	.150	16	17	18	.295	8	8	29	.439	6	.....
8	.163	15	15	19	.308	8	.....	30	.453	6	6
9	.176	14	14	20	.321	8	7.5	.....	.....	.....	.....
10	.189	13	13	21	.334	8	.....	.....	.....	.....	.....

Dimensions of Machine Screw Heads, A. S. M. E. Standard

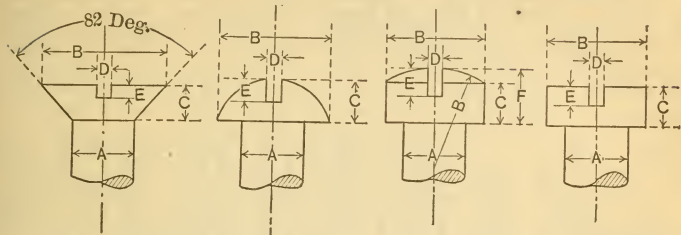

FLAT HEAD.  
(1)

ROUND HEAD.\*  
(2)

OVAL FILLISTER  
HEAD.  
(3)

FLAT FILLIS-  
TER HEAD.  
(4)

\* Form of head is semi-elliptical in axial cross section.

Dimensions

A = Diam. of Body.	D = Width of Slot = $0.173 A + 0.015$ .		
B = Diam. of Head and rad. of oval (3).			
C = Height of Head or Side of Head (3).			
E = Depth of Slot. $\frac{1}{2} C$			
F = Height of Head (3).			
(1)	(2)	(3)	(4)
$2A - 0.008$	$1.85A - 0.005$	$1.64A - 0.009$	$1.64A - 0.009$
$\frac{A - 0.008}{1.739}$	$0.7A$	$0.66A - 0.002$	$0.66A - 0.002$
$\frac{1}{2} C$	$\frac{1}{2} C + 0.01$	$\frac{1}{2} F$	$\frac{1}{2} C$
.....	.....	$0.134B + C$	.....

A	B (1)	B (2)	B (3, 4)	C (1)	C (2)	C (3, 4)	D	E (1)	E (2)	E (3)	E (4)	F (3)
0.060	0.112	0.106	0.0894	0.030	0.042	0.0376	0.025	0.010	0.031	0.025	0.019	0.0496
.073	.138	.130	.1107	.037	.051	.0461	.028	.012	.035	.030	.023	.0609
.086	.164	.154	.1320	.045	.060	.0548	.030	.015	.040	.036	.027	.0725
.099	.190	.178	.1530	.052	.069	.0633	.032	.017	.044	.042	.032	.0838
.112	.216	.202	.1747	.060	.078	.0719	.034	.020	.049	.048	.036	.0953
.125	.242	.226	.1960	.067	.087	.0805	.037	.022	.053	.053	.040	.1068
.138	.268	.250	.2170	.075	.097	.0890	.039	.025	.058	.059	.044	.1180
.151	.294	.274	.2386	.082	.106	.0976	.041	.027	.063	.065	.049	.1296
.164	.320	.298	.2599	.090	.115	.1062	.043	.030	.067	.071	.053	.1410
.177	.346	.322	.2813	.097	.124	.1148	.046	.032	.072	.076	.057	.1524
.190	.372	.346	.3026	.105	.133	.1234	.048	.035	.076	.082	.062	.1639
.216	.424	.394	.3452	.120	.151	.1405	.052	.040	.085	.093	.070	.1868
.242	.476	.443	.3879	.135	.169	.1577	.057	.045	.094	.105	.079	.2097
.268	.528	.491	.4305	.150	.188	.1748	.061	.050	.104	.116	.087	.2325
.294	.580	.539	.4731	.164	.206	.1920	.066	.055	.113	.128	.096	.2554
.320	.632	.587	.5158	.179	.224	.2092	.070	.060	.122	.104	.104	.2783
.346	.684	.635	.5584	.194	.242	.2263	.075	.065	.131	.150	.113	.3011
.372	.736	.683	.6010	.209	.260	.2435	.079	.070	.140	.162	.122	.3240
.398	.788	.731	.6437	.224	.279	.2606	.084	.075	.149	.173	.130	.3469
.424	.840	.779	.6863	.239	.297	.2778	.088	.080	.158	.185	.139	.3698
.450	.892	.827	.7290	.254	.315	.2950	.093	.085	.167	.196	.147	.3927

Standard Studs.—The Upson Nut Co., Cleveland, gives (1914) the following formulæ for the dimensions of standard stud bolts with either V or U. S. Standard threads: A = diam. of stud; B = length of short thread; C = length of unthreaded portion; D = length of long thread; E = total length of stud, all in inches.  $B = A + \frac{1}{8}$ ;  $C = A$ ;  $D = E - (B + C)$ .

**Dimensions of Standard Set and Cap-Screws.**

Compiled from tables of leading manufacturers. All dimensions in inches. *D* = short diam. of head, square and hex. heads, or diam. of round head; *L* = maximum length, *l* = minimum length under head; *L'*, *l'*, maximum and minimum length over all; *H* = length of head.

Diam. of Screws ...	1/8	3/16	1/4	5/16	3/8	7/16	1/2	9/16	5/8	3/4	7/8	1	1 1/8	1 1/4
Threads per In. ...	40	24	20	18	16	14	12 or 13	12	11	10	9	8	7	7
Sq. Head Set-Screws.	<i>D</i> ...	...	1/4	5/16	3/8	7/16	1/2	9/16	5/8	3/4	7/8	1	1 1/8	1 1/4
	<i>L</i> ...	...	3	3	3	4	4	4	4 1/2	4 3/4	5	5	5	5
	<i>l</i> ...	...	1/2	1/2	1/2	5/8	5/8	3/4	3/4	1	1 1/4	1 1/2	1 3/4	2
Sq. Head Cap-Screws.	<i>D</i> ...	...	3/8	7/16	1/2	9/16	5/8	11/16	3/4	7/8	1 1/8	1 1/4	1 3/8	1 1/2
	<i>H</i> ...	...	1/4	5/16	3/8	7/16	1/2	9/16	5/8	3/4	7/8	1	1 1/8	1 1/4
	<i>L</i> ...	...	3	3	3	4	4	4	4 1/2	4 3/4	5	5	5	5
	<i>l</i> ...	...	3/4	3/4	3/4	3/4	3/4	1	1	1 1/4	1 1/2	1 3/4	2	2
Hexagon Head Cap-Screws.	<i>D</i> ...	...	7/16	1/2	9/16	5/8	3/4	13/16	7/8	1	1 1/8	1 1/4	1 3/8	1 1/2
	<i>H</i> ...	...	1/4	5/16	3/8	7/16	1/2	9/16	5/8	3/4	7/8	1	1 1/8	1 1/4
	<i>L</i> ...	...	3	3	3	4	4	4	4 1/2	4 3/4	5	5	5	5
	<i>l</i> ...	...	3/4	3/4	3/4	3/4	3/4	1	1	1 1/4	1 1/2	1 3/4	2	2
Round and Filister Head Cap-Screws.	<i>D</i> ...	3/16	1/4	3/8	7/16	9/16	5/8	3/4	13/16	7/8	1	1 1/8	1 1/4	...
	<i>H</i> ...	1/8	3/16	1/4	5/16	3/8	7/16	1/2	9/16	5/8	3/4	7/8	1	...
	<i>L</i> ...	3	3 1/4	3 1/2	3 3/4	4	4 1/4	6	6	6	6	6	6	...
	<i>l</i> ...	3/4	3/4	3/4	3/4	3/4	3/4	1	1	1 1/4	1 1/2	1 3/4	2	...
Flat Head Cap-Screws.	<i>D</i> ...	1/4	3/8	15/32	5/8	3/4	13/16	7/8	1	1 1/8	1 1/4	...	...	...
	<i>L'</i> ...	1 3/4	2	2 1/4	2 3/4	3	3	3	3	3	3	...	...	...
	<i>l'</i> ...	3/4	3/4	3/4	3/4	3/4	1	1 1/4	1 1/2	1 3/4	2	...	...	...
Button-Head Cap-Screws.	<i>D</i> ...	7/32	5/16	7/16	9/16	5/8	3/4	13/16	15/16	1	1 1/4	...	...	...
	<i>L</i> ...	1 3/4	2	2 1/4	2 1/2	2 3/4	3	3	3	3	3	...	...	...
	<i>l</i> ...	3/4	3/4	3/4	3/4	3/4	3/4	1	1 1/4	1 1/2	1 3/4	...	...	...
Socket Set-Screws, Length.....	.....	.....	.....	11/32	7/16	1/2	9/16	5/8	11/16	7/8	1	1 1/4	.....	.....

Threads are U. S. Standard. On all cap-screws of 1 in. and less in diam. and 4 in. long and under, threads are cut 3/4 of the length of body; longer than 4 in. threads are cut 1/2 of the length of body. Lengths advance by 1/4 in. from minimum to maximum.

**Oval Head Rivets—Approximate Number in One Pound**  
(Garland Nut & Rivet Co., Pittsburgh.)

Diam.	7/16	3/8	5/16	1/4	3/16	1/8	Diam.	7/16	3/8	5/16	1/4	3/16	1/8
Length							Length						
1/4	.....	.....	..	123	262	630	1 5/8	10 1/2	16	23	40	71	166
3/8	.....	.....	56	102	210	500	1 3/8	10	15	21	36	68	160
1/2	21	34	49	90	177	415	1 7/8	9 1/2	14 1/2	20	35	62	145
5/8	19	30	45	78	150	350	2	9	14	18	32	60	140
3/4	17	27	39	70	132	300	2 1/4	8 1/2	13	16	29	55	...
7/8	16	24	35	62	110	280	2 1/2	8	12	15	27	48	...
1	15	22	33	56	100	250	2 3/4	7 1/2	11	14	25	44	...
1 1/8	14	21	31	50	96	...	3	7	10	13	23	42	...
1 1/4	13	20	27	46	88	205	3 1/2	6	9	12	20	...	...
1 3/8	12	18	26	44	80	...	4	.....	8	..	18	...	...
1 1/2	11	17	24	42	77	178							

Small rivets are made to fit holes of their rated size; the actual diameter may vary slightly from the decimals given below:

Size.....	3/32	7/64	1/8	9/64	5/32	11/64	3/16
Approx. diam.....	.094	.109	.125	.140	.155	.170	.185
Size.....	7/32	1/4	9/32	5/16	3/8	7/16	
Approx. diam.....	.215	.245	.275	.305	.365	.425	



**Weight of 100 Cone Head Rivets.**  
(Hoopes & Townsend, Philadelphia, 1914.)

L'gth Under Head In.	Scant Diameter, In.									
	1/2	9/16	5/8	11/16	3/4	13/16	7/8	1	1 1/8*	1 1/4*
3/4	8.6	11.9	15.5	.....	.....	.....	...	...	...	...
7/8	9.3	12.7	16.5	.....	.....	.....	...	...	...	...
1	9.9	13.6	17.6	22.4	28.1	34.5	...	...	...	...
1 1/8	10.6	14.4	18.6	23.6	29.6	36.3	...	...	...	...
1 1/4	11.2	15.2	19.6	24.9	31.1	38.1	46	65	...	...
1 3/8	11.9	16.1	20.7	26.1	32.6	39.8	48	68	93	...
1 1/2	12.5	16.9	21.7	27.4	34.1	41.6	50	70	96	127
1 5/8	13.2	17.7	22.7	28.6	35.6	43.4	52	73	100	132
1 3/4	13.8	18.6	23.8	29.9	37.1	45.1	54	76	103	136
1 7/8	14.5	19.4	24.8	31.1	38.6	46.9	56	78	107	140
2	15.1	20.2	25.8	32.4	40.1	48.7	58	81	110	145
2 1/8	15.8	21.0	26.9	33.7	41.6	50.5	60	84	114	149
2 1/4	16.4	21.9	27.9	34.9	43.1	52.2	62	87	117	153
2 3/8	17.1	22.7	28.9	36.2	44.6	54.0	64	89	121	158
2 1/2	17.8	23.5	30.0	37.4	46.1	55.8	66	92	124	162
2 5/8	18.4	24.4	31.0	38.7	47.6	57.5	68	95	128	166
2 3/4	19.1	25.2	32.0	39.9	49.1	59.3	70	97	132	171
2 7/8	19.7	26.0	33.1	41.2	50.6	61.1	72	100	135	175
3	20.4	26.9	34.1	42.5	52.1	62.8	74	103	139	179
3 1/4	21.7	28.5	36.2	45.0	55.1	66.4	78	108	146	188
3 1/2	22.9	30.2	38.2	47.5	58.1	69.9	83	114	153	197
3 3/4	24.3	31.9	40.3	50.0	61.1	73.4	87	119	160	205
4	25.6	33.5	42.4	52.5	64.1	77.0	91	124	167	214
4 1/4	26.9	35.2	44.4	55.0	67.1	80.5	95	130	174	223
4 1/2	28.2	36.9	46.5	57.5	70.1	84.0	99	135	181	232
4 3/4	29.5	38.5	48.6	60.0	73.1	87.6	103	141	188	240
5	30.8	40.2	50.6	62.6	76.1	91.1	107	146	195	249
5 1/4	32.1	41.9	52.7	65.1	79.1	94.6	111	151	202	258
5 1/2	33.4	43.5	54.8	67.6	82.1	98.2	115	157	209	266
5 3/4	34.7	45.2	56.8	70.1	85.1	101.7	120	162	216	275
6	36.0	46.8	58.9	72.6	88.1	105.2	124	167	223	284
6 1/2	38.7	50.2	63.0	77.6	94.1	112.3	132	178	237	301
7	41.3	53.5	67.2	82.7	100.2	119.4	140	189	251	319
Wgt. of Hds.	4.7	6.9	9.3	12.3	16.1	20.4	26	38	54	75

\* All Rivets larger than one inch are made to exact diameter.

**Tinners' Rivets. Flat Heads.** (Garland Nut & Rivet Co.)

Diam., In.	Length, In.	Wt. per 1000.	Diam., In.	Length, In.	Wt. per 1000.	Diam., In.	Length, In.	Wt. per 1000.	Diam., In.	Length, In.	Wt. per 1000.
0.070	1/8	4 oz.	0.115	13/64	1 lb.	0.160	5/16	3 lbs.	0.225	7/16	8
.080	9/64	6	.120	7/32	1 1/4	.163	21/64	3 1/2	.230	29/64	9
.090	5/32	8	.125	15/64	1 1/2	.173	11/32	4	.233	15/32	10
.094	11/64	10	.133	1/4	1 3/4	.185	3/8	5	.253	1/2	12
.101	3/16	12	.140	17/64	2	.200	25/64	6	.275	33/64	14
.109	3/16	14	.147	9/32	2 1/2	.215	13/32	7	.293	17/32	16

## Shearing Value, Area of Rivets, and Bearing Value of Riveted Plates.

Shearing Value = Area of Rivet  $\times$  Allowable Shearing Stress Per Sq. In.Bearing Value = Diameter of Rivet  $\times$  Thickness of Plate  $\times$  Allowable Bearing Stress Per Square Inch.

Dia. of Rivet, In.	Area, Sq. In.	Single Shear 6,000 Lbs. Sq. In.	Double Shear 6,000 Lbs. Sq. In.	Bearing Value for Different Thicknesses of Plate in Inches at 12,000 Lb. per Square Inch.									
				1/4 In.	5/16 In.	3/8 In.	7/16 In.	1/2 In.	5/8 In.	3/4 In.	7/8 In.	1 In.	
				1/2	0.1964	1178	2356	1500	1875	2250	2625	3000	....
5/8	0.3068	1841	3682	1875	2344	2813	3281	3750	4688	....	....	....	
3/4	0.4418	2651	5301	2250	2813	3375	3938	4500	5625	6750	....	....	
7/8	0.6013	3608	7216	2625	3281	3938	4594	5250	6563	7875	9188	....	
1	0.7854	4712	9425	3000	3750	4500	5250	6000	7500	9000	10500	12000	

Dia. of Rivet, In.	Area, Sq. In.	Single Shear 7,500 Lbs. Sq. In.	Double Shear 7,500 Lbs. Sq. In.	Bearing Value for Different Thicknesses of Plate in Inches at 15,000 Lbs. per Square Inch.									
				1/4 In.	5/16 In.	3/8 In.	7/16 In.	1/2 In.	5/8 In.	3/4 In.	7/8 In.	1 In.	
				1/2	0.1964	1473	2945	1875	2344	2813	3281	3750	....
5/8	0.3068	2301	4602	2344	2930	3516	4102	4688	5859	....	....	....	
3/4	0.4418	3313	6627	2813	3516	4219	4922	5625	7031	8438	....	....	
7/8	0.6013	4510	9020	3281	4102	4922	5742	6563	8203	9844	11484	....	
1	0.7854	5891	11781	3750	4688	5625	6563	7500	9375	11250	13125	15000	

Dia. of Rivet, In.	Area, Sq. In.	Single Shear 10,000 Lbs. Sq. In.	Double Shear 10,000 Lbs. Sq. In.	Bearing Value for Different Thicknesses of Plate in Inches at 20,000 Lbs. per Square Inch.									
				1/4 In.	5/16 In.	3/8 In.	7/16 In.	1/2 In.	5/8 In.	3/4 In.	7/8 In.	1 In.	
				1/2	0.1964	1964	3927	2500	3125	3750	4375	5000	....
5/8	0.3068	3068	6136	3125	3906	4688	5469	6250	7813	....	....	....	
3/4	0.4418	4418	8836	3750	4688	5625	6563	7500	9375	11250	....	....	
7/8	0.6013	6013	12026	4375	5469	6563	7656	8750	10938	13125	15313	....	
1	0.7854	7854	15708	5000	6250	7500	8750	10000	12500	15000	17500	20000	

Dia. of Rivet.	Area in Square Inches.	6,000 Lbs. per Sq. In.		Bearing Value for Different Thicknesses of Plate in Inches at 12,000 Lb. per Square Inch.						
		Single Shear	Double Shear.	1/8 In.	3/16 In.	1/4 In.	5/16 In.	11/32 In.	3/8 In.	7/16 In.
				3/16	0.0274	164	328	281	422	....
1/4	0.0491	295	589	375	563	750	....	....	....	....
5/16	0.0764	458	917	468	703	938	1172	....	....	....
11/32	0.0924	554	1109	515	773	1031	1289	1418	....	....
3/8	0.1104	662	1325	563	844	1125	1406	1547	1687	....
7/16	0.1499	899	1799	656	984	1313	1640	1804	1969	2297

All bearing values above or to right of zigzag lines are greater than double shear. Values between upper and lower zigzag lines are less than double and greater than single shear. Values below and to left of lower zigzag lines are less than single shear.

**LENGTH OF RIVETS REQUIRED FOR VARIOUS GRIPS**  
(American Bridge Co. Standard—Dimensions in Inches.)

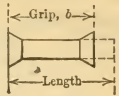
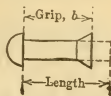
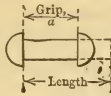
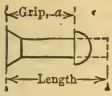

Grip a	Diameter, In.					Grip b	Diameter, In.				
	1/2	5/8	3/4	7/8	1		1/2	5/8	3/4	7/8	1
1/2	1 1/2	1 3/4	1 7/8	2	2 1/8	1/2	1 1/8	1 1/4	1 1/4	1 3/8	1 3/8
5/8	1 5/8	1 7/8	2	2 1/8	2 1/4	5/8	1 1/4	1 3/8	1 3/8	1 1/2	1 1/2
3/4	1 3/4	2	2 1/8	2 1/4	2 3/8	3/4	1 3/8	1 1/2	1 1/2	1 5/8	1 5/8
7/8	1 7/8	2 1/8	2 1/4	2 3/8	2 1/2	7/8	1 1/2	1 5/8	1 5/8	1 3/4	1 3/4
1	2	2 1/4	2 3/8	2 1/2	2 5/8	1	1 5/8	1 3/4	1 3/4	1 7/8	1 7/8
1/4	2 1/4	2 1/2	2 5/8	2 3/4	2 7/8	1/4	1 7/8	2	2	2 1/8	2 1/8
1/2	2 5/8	2 7/8	3	3 1/8	3 1/4	1/2	2 1/8	2 1/4	2 3/8	2 3/8	2 1/2
3/4	3	3 1/4	3 3/8	3 1/2	3 5/8	3/4	2 1/2	2 5/8	2 3/4	2 3/4	2 7/8
2	3 1/4	3 1/2	3 5/8	3 3/4	3 7/8	2	2 3/4	2 7/8	3	3	3 1/8
1/4	3 1/2	3 3/4	3 7/8	4	4 1/8	1/4	3	3 1/8	3 1/4	3 1/4	3 3/8
1/2	3 3/4	4	4 1/8	4 1/4	4 3/8	1/2	3 1/4	3 3/8	3 1/2	3 1/2	3 5/8
3/4	4	4 1/4	4 3/8	4 1/2	4 5/8	3/4	3 1/2	3 5/8	3 3/4	3 3/4	3 7/8
3	4 3/8	4 5/8	4 3/4	4 7/8	5	3	3 7/8	4	4	4 1/8	4 1/4
1/4	4 5/8	4 7/8	5	5 1/8	5 1/4	1/4	4 1/8	4 1/4	4 1/4	4 3/8	4 1/2
1/2	4 7/8	5 1/8	5 1/4	5 3/8	5 1/2	1/2	4 3/8	4 1/2	4 1/2	4 5/8	4 3/4
3/4	5 1/8	5 3/8	5 1/2	5 5/8	5 3/4	3/4	4 5/8	4 3/4	4 3/4	4 7/8	5
4	5 3/8	5 5/8	5 3/4	5 7/8	6	4	4 7/8	5	5	5 1/8	5 1/4
1/4	5 3/4	6	6 1/8	6 1/4	6 3/8	1/4	5 1/4	5 3/8	5 3/8	5 1/2	5 5/8
1/2	6 1/8	6 3/8	6 1/2	6 5/8	6 3/4	1/2	5 5/8	5 3/4	5 3/4	5 3/4	5 7/8
3/4	6 3/8	6 5/8	6 3/4	6 7/8	7	3/4	5 7/8	6	6	6	6 1/8
5	6 5/8	6 7/8	7	7 1/8	7 1/4	5	6 1/8	6 1/4	6 1/4	6 1/4	6 3/8

**Weight of 100 Lag Screws.**  
(Hoopes & Townsend, Philadelphia, 1914.)

Length Under Head to Point.	Diameter, Inches.										
	5/16	3/8	7/16	1/2	9/16	5/8	3/4	7/8	1	1 1/8	1 1/4
in.	lb.	lb.	lb.	lb.	lb.	lb.	lb.	lb.	lb.	lb.	lb.
1 1/2	4.2	6.5	9.2	13.0	.....	.....	.....	.....	.....	.....	.....
1 3/4	4.7	7.1	10.0	13.8	.....	.....	.....	.....	.....	.....	.....
2	5.2	7.7	10.9	14.9	23.0	24.8	.....	.....	.....	.....	.....
2 1/4	5.7	8.4	11.8	16.1	24.5	27.3	.....	.....	.....	.....	.....
2 1/2	6.2	9.2	12.7	17.4	26.0	29.0	43.0	.....	.....	.....	.....
3	7.2	10.6	14.6	19.0	29.2	32.9	48.3	75.0	.....	.....	.....
3 1/2	8.2	12.0	16.6	21.5	32.5	36.9	53.8	78.5	90	.....	.....
4	9.2	13.5	18.8	24.0	35.9	41.0	59.6	82.0	99	.....	.....
4 1/2	10.2	15.0	20.7	26.5	39.3	44.9	65.5	86.0	108	.....	.....
5	11.3	16.5	22.8	29.0	42.7	48.8	71.5	90.0	118	150	.....
5 1/2	12.4	18.0	24.9	31.5	46.1	52.7	77.5	98.0	128	163	.....
6	13.5	19.5	27.0	34.0	49.5	56.6	83.5	106.0	138	176	240
7	.....	.....	31.1	39.0	56.3	64.5	95.5	122.5	158	203	270
8	.....	.....	35.2	44.0	63.1	72.5	107.6	139.0	178	230	300
9	.....	.....	.....	49.0	69.9	80.5	119.8	155.5	198	257	332
10	.....	.....	.....	54.0	76.7	88.5	131.0	172.0	219	284	365
11	.....	.....	.....	.....	83.5	96.5	143.1	188.5	240	311	395
12	.....	.....	.....	.....	90.5	104.5	155.4	205.0	261	338	425
13	.....	.....	.....	.....	.....	112.5	167.6	221.5	282	365	459
14	.....	.....	.....	.....	.....	121.0	179.8	238.0	304	393	493
15	.....	.....	.....	.....	.....	129.5	192.0	255.0	326	421	527
16	.....	.....	.....	.....	.....	138.0	204.0	272.0	348	449	562
Thds. per in.	10	7	7	6	5	5	4 1/2	4 1/2	3	3	3

**Approximate Weight of Machine Bolts per 100, Square Heads and Square Nuts.** (Hoopes & Townsend, Philadelphia, 1914.)

Length Under Head to Point, In.	Diameter.													
	1/4 In.	3/8 In.	7/16 In.	1/2 In.	9/16 In.	5/8 In.	3/4 In.	7/8 In.	1 In.	1 1/4 In.	1 1/2 In.	1 3/4 In.	2 In.	
1 1/4	3.1	8.4	12.5	17.7	24.3	30.7	50.4	.....	.....	.....	.....	.....	.....	
1 1/2	3.4	9.2	13.6	19.1	26.0	32.8	53.5	.....	.....	.....	.....	.....	.....	
2	4.1	10.8	15.7	21.8	29.5	37.1	59.7	89.4	125.7	.....	.....	.....	.....	
2 1/2	4.8	12.3	17.8	24.6	33.0	41.4	65.9	97.3	136.8	246.3	.....	.....	.....	
3	5.5	13.8	19.9	27.4	36.5	45.7	72.1	105.7	147.8	263.5	470	.....	.....	
3 1/2	6.2	15.3	21.8	29.8	40.0	50.0	78.3	114.2	158.9	280.8	495	.....	.....	
4	6.9	16.9	24.0	32.6	43.5	54.4	84.5	122.6	169.9	298.1	520	720	.....	
4 1/2	7.5	18.4	26.1	35.4	46.7	58.3	90.3	130.5	179.4	314.1	545	753	.....	
5	8.2	19.9	28.2	38.1	50.2	62.6	96.5	138.9	190.4	331.4	570	786	1180	
5 1/2	8.9	21.5	30.3	40.9	53.7	66.9	102.7	147.4	201.5	348.6	595	820	1225	
6	9.6	23.0	32.4	43.7	57.2	71.3	108.9	155.8	212.5	365.9	620	854	1270	
6 1/2	10.3	24.6	34.5	46.4	60.7	75.6	115.1	164.3	223.6	383.1	645	888	1315	
7	11.0	26.1	36.6	49.2	64.2	79.9	121.3	172.7	234.6	400.4	670	922	1360	
7 1/2	11.7	27.7	38.8	51.9	67.6	84.2	127.6	181.2	245.6	417.7	695	956	1405	
8	12.4	29.2	40.9	54.7	71.1	88.5	133.8	189.6	256.7	434.9	725	990	1450	
9	13.7	32.4	44.9	60.0	77.8	96.8	145.7	205.9	278.0	468.2	775	1058	1540	
10	15.1	35.5	49.1	65.5	84.8	105.4	158.2	222.8	300.0	502.7	825	1126	1630	
11	16.5	38.6	53.4	71.0	91.8	114.1	170.6	239.8	322.2	537.3	875	1194	1720	
12	17.9	41.7	57.6	76.5	98.8	122.7	183.0	256.7	344.3	571.8	925	1262	1810	
13	19.3	44.8	61.8	82.0	105.5	131.0	195.4	273.6	366.3	606.3	975	1330	1900	
14	20.6	47.9	66.0	87.6	112.5	139.6	207.9	290.5	388.4	640.8	1025	1398	1990	
15	22.0	51.0	70.3	93.1	119.5	148.2	220.3	307.4	410.5	675.3	1075	1468	2080	
16	23.4	54.1	74.5	98.6	126.4	156.9	232.7	324.3	432.6	709.8	1125	1536	2170	
17	24.8	57.2	78.7	104.1	133.4	165.5	245.1	341.2	454.7	744.3	1175	1604	2260	
18	26.2	60.3	82.9	109.7	140.4	174.1	257.6	358.1	476.8	778.9	1225	1672	2350	
20	28.9	66.5	91.4	120.7	154.4	191.4	282.4	392.0	521.0	847.9	1325	1808	2530	
22	31.7	72.7	99.9	131.7	168.4	208.6	307.3	425.8	565.1	916.9	1425	1944	2710	
24	34.4	78.9	108.3	142.8	182.4	225.9	332.1	459.6	609.3	986.0	1525	2080	2890	
26	37.2	85.2	116.8	153.8	196.3	243.1	357.0	493.4	653.5	1055.0	1625	2216	3070	
28	40.0	91.4	125.2	164.9	210.3	260.4	381.8	527.3	697.7	1124.0	1725	2352	3250	
30	42.7	97.6	133.7	175.9	224.3	277.7	406.7	561.1	741.9	1193.0	1825	2488	3450	

**Weight per 100 Nuts.**

Square	0.7	2.5	3.9	5.7	8.1	9.9	16.8	26.9	40.1	77.8	162	257	381
Hexagon	0.6	2.1	3.2	4.8	6.7	8.3	14.0	22.3	33.4	64.0	134	207	307
Diff.	0.1	0.4	0.7	0.9	1.4	1.6	2.8	4.6	6.7	13.8	28	50	74

**Weight of 100 Heads.**

Square	0.8	2.4	4.0	5.9	8.8	11.4	20.0	31.4	44.9	90.9	144	231	345
Hexagon	0.7	2.2	3.5	5.3	7.9	10.3	17.0	28.2	39.4	83.9	132	215	302
Diff.	0.1	0.2	0.5	0.6	0.9	1.1	3.0	3.2	5.5	7.0	12	16	43

**For Weight of Bolts with Hex. Heads and Hex. Nuts.**

Subtract	0.2	0.6	1.2	1.5	2.3	2.7	5.8	7.8	12.2	20.8	40	66	117
----------	-----	-----	-----	-----	-----	-----	-----	-----	------	------	----	----	-----

**Sizes of Cast Washers.** (Upson Nut Co., Cleveland, 1914.)

Diam.	Hole.	Thick.	Bolt.	Weight. Lbs.	Diam.	Hole.	Thick.	Bolt.	Weight. Lbs.
In. 2 1/4	5/8	1 1/16	1/2	1/2	4	1 1/8	15/16	1	15/8
2 3/4	3/4	3/4	5/8	5/8	4 1/2	1 1/4	1	1 1/8	2 1/4
3	7/8	13/16	3/4	3/4	5	1 3/8	1 1/8	1 1/4	3
3 1/2	1	7/8	7/8	1 1/4	6	1 3/4	1 1/4	1 1/2	5



**Weight and Dimensions of Hanger Bolts.**

(Hoopes & Townsend, Philadelphia, 1914.)

One end cut with deep wood screw thread, the other fitted with a standard cold punched, chamfered and trimmed square nut.

Diameter, In.	1/2	5/8	3/4	7/8	1	1 1/8	1 1/4	1 3/8	1 1/2
Length Over All, In.	Approximate Weight per 100.								
4	24	.....	.....	.....	.....	.....	.....	.....	.....
6	34	53	80	106	.....	.....	.....	.....	.....
8	44	67	97	138	174	257	301	.....	.....
10	54	81	114	166	217	299	351	456	532
12	.....	95	134	196	259	332	401	511	597
14	.....	.....	154	226	295	374	451	566	677
16	.....	.....	.....	256	329	417	501	621	747
Threads per inch:									
Nut end.....	13	11	10	9	8	7	7	6	6
Screw end.....	6	5	4 1/2	4 1/2	3	3	3	2 1/2	2 1/2

**Turnbuckles.**

(Cleveland City Forge and Iron Co.)

Standard sizes made with right and left threads. D = outside diameter

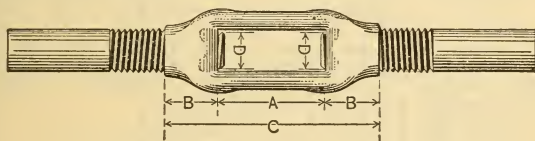

FIG. 76.

of screw. A = length in clear between heads = 6 ins. for all sizes, B = length of tapped heads = 1 1/2 D nearly. C = 6 ins. + 3 D nearly.

**Wrought Washers, Manufacturers' Standard.**

(Upson Nut Co., Cleveland, 1914.)

Diam.	Hole.	Thickness, B. W. G.	Bolt.	No. in 100 Lb.	Weight per 1000, Lb.	Diam.	Hole.	Thickness, B. W. G.	Bolt.	No. in 100 Lb.	Weight per 1000, Lb.
In.	In.	No.	In.			In.	In.	No.	In.		
9/16	1/4	18	3/16	39400	2.53	2 1/2	1 1/16	8	1	568	176
3/4	5/16	16	1/4	15600	6.4	2 3/4	1 1/4	8	1 1/8	473	211
7/8	3/8	16	5/16	11250	8.8	3	1 3/8	8	1 1/4	364	261
1	7/16	14	3/8	6800	14.7	3 1/4	1 1/2	7	1 3/8	275	364
1 1/4	1/2	14	7/16	4300	21.	3 1/2	1 5/8	7	1 1/2	256	390
1 3/8	9/16	12	1/2	2600	38.4	3 3/4	1 3/4	7	1 5/8	220	454
1 1/2	5/8	12	9/16	2250	44.4	4	1 7/8	7	1 3/4	197	508
1 3/4	11/16	10	5/8	1300	77.	4 1/4	2	7	1 7/8	174	575
2	13/16	9	3/4	900	111.	4 1/2	2 1/8	7	2	160	625
2 1/4	15/16	8	7/8	782	153.	4 3/4	2 3/8	5	2 1/4	122	820
						5	2 5/8	4	2 1/2	106	943



## Material Required for One Mile of Single Track. (Carnegie Steel Co., 1913.)

Rails.			Splice Bars.				Bolts and Nuts.			Spikes.			Total Weight per Mile of Single Track, Gross Tons.	
Wgt. per Yard, Lb.	Hgt. of Rail, Width of Base.	Weight per Mile of Single Track, Gross Tons.	Length, In.	Weight per Pair, Lb.	Pairs per Mile of Single Track.	Weight per Mile of Single Track, Gross Tons.	No. per Joint	Size, In.	No. per Mile of Single Track.	Weight per Mile of Single Track, Gross Tons.	Size, In.	No. per Mile of Single Track.	Weight per Mile of Single Track, Gross Tons.	
100	5 3/4	157.14	34	87.00	326	12.66	6	1 X 4 1/2	1956	1.54	5 1/2 X 9/16	10640	2.80	174.14
90	5 3/8	141.43	34	74.00	326	10.77	6	7/8 X 4 1/4	1956	1.08	5 1/2 X 9/16	10640	2.80	156.08
85	5 3/16	133.57	34	68.13	326	9.92	6	3/4 X 4 1/4	1956	0.76	5 1/2 X 9/16	10640	2.80	147.05
80	5	125.71	34	63.13	326	9.07	6	3/4 X 4 1/8	1956	.75	5 1/2 X 9/16	10640	2.80	138.33
75	4 13/16	117.86	34	58.50	326	8.52	6	3/4 X 4	1956	.74	5 1/2 X 9/16	10640	2.80	129.92
70	4 5/8	110.00	34	54.64	326	7.96	6	3/4 X 3 3/4	1956	.71	5 1/2 X 9/16	10640	2.80	121.47
65	4 7/16	102.12	24	35.55	326	5.17	4	3/4 X 3 3/4	1304	.48	5 1/2 X 9/16	10640	2.80	110.57
60	4 1/4	94.29	24	32.40	326	4.71	4	3/4 X 3 1/2	1304	.46	5 1/2 X 9/16	10640	2.80	102.26
55	4 1/16	86.43	24	28.90	326	4.20	4	3/4 X 3 1/2	1304	.46	5 1/2 X 9/16	10640	2.80	93.89
50	3 7/8	78.57	24	25.50	326	3.71	4	3/4 X 3 1/4	1304	.44	5 1/2 X 9/16	10640	2.80	85.52
45	3 11/16	70.71	20	18.75	364	3.04	4	3/4 X 3	1456	.47	5 1/2 X 9/16	10640	2.80	77.02
40	3 1/2	62.86	20	16.10	364	2.62	4	3/4 X 3	1456	.47	5 X 1 1/2	10640	1.94	67.89
35	3 5/16	55.00	16 1/8	12.10	364	1.97	4	5/8 X 2 1/2	1456	.30	4 1/2 X 1 1/2	10640	1.78	59.05
30	3 1/8	47.14	16 1/8	10.45	364	1.70	4	5/8 X 2 1/2	1456	.30	4 X 1 1/2	10640	1.59	50.73
25	2 3/4	39.29	16 1/8	5.70	364	0.93	4	1/2 X 2 1/4	1456	.16	4 X 1 1/2	10640	1.59	41.97
20	2 5/8	31.43	16 1/8	4.86	364	.79	4	1/2 X 2	1456	.16	3 1/2 X 1 1/2	10640	1.53	33.91
16	2 3/8	25.14	16 1/8	4.36	364	.71	4	1/2 X 1 3/4	1456	.15	3 1/2 X 3/8	10640	0.81	26.81
14	2 1/16	22.00	16 1/8	3.44	364	.56	4	1/2 X 1 3/4	1456	.15	3 X 3/8	10640	.77	23.48
12	2	18.86	16 1/8	3.44	364	.56	4	1/2 X 1 3/4	1456	.15	3 X 3/8	10640	.77	20.34
10	1 3/4	15.71	16 1/8	2.60	364	.42	4	3/8 X 1 1/2	1456	.07	2 1/2 X 5/16	10640	.43	16.63
8	1 9/16	12.57	16 1/8	2.00	364	.33	4	3/8 X 1 1/2	1456	.07	2 1/2 X 5/16	10640	.43	13.40

APPROXIMATE NUMBER OF WIRE NAILS PER POUND.

(American Steel and Wire Co., 1908.)

Length, Inches.

Wire Gauge. B.W.G.	3/16	1/4	3/8	1/2	5/8	3/4	1	1 1/4	1 1/2	1 3/4	2	2 1/2	3	3 1/2	4	4 1/2	5	6	7	8	9	10	11	12
3/8 in.	.....	.....	.....	.....	.....	.....	.....	33	27	23	20	16	14	12	10	9	8	7	6	5	4 1/2	4	3 3/4	3 1/4
0	.....	.....	.....	.....	.....	.....	57	34	29	25	21	17	15	13	11	10	9	8	7	5 1/2	5	4 1/8	4	3 1/2
5/16 in.	.....	.....	.....	.....	.....	.....	65	45	38	32	28	23	19	16	14	13	11	10	8	7	6	5 1/2	5	4 1/2
2	.....	.....	.....	.....	.....	.....	76	52	44	37	32	26	22	19	16	14	13	11	9	8	7	6 1/2	6	5 1/2
3	.....	.....	.....	.....	.....	.....	90	60	50	43	38	30	25	22	19	17	15	13	11	10	8	7 1/2	7	6 1/2
4	.....	.....	.....	.....	.....	.....	106	72	60	51	45	36	30	26	23	20	18	15	13	11	10	9	.....	.....
5	.....	.....	.....	.....	.....	.....	123	85	71	60	53	42	35	30	26	24	21	18	15	.....	.....	.....	.....	.....
6	.....	.....	.....	.....	.....	.....	149	99	82	71	62	50	41	35	31	28	25	21	18	.....	.....	.....	.....	.....
7	.....	.....	.....	.....	.....	.....	172	120	100	85	75	60	50	43	37	33	30	25	.....	.....	.....	.....	.....	.....
8	.....	.....	.....	.....	.....	.....	207	137	115	98	86	69	57	49	43	39	35	29	.....	.....	.....	.....	.....	.....
9	.....	.....	.....	.....	.....	.....	248	165	138	118	103	82	69	59	52	46	41	.....	.....	.....	.....	.....	.....	.....
10	.....	.....	.....	.....	.....	.....	314	198	165	142	124	99	83	71	62	55	50	.....	.....	.....	.....	.....	.....	.....
11	.....	.....	.....	.....	.....	.....	411	251	209	179	157	125	105	90	79	70	.....	.....	.....	.....	.....	.....	.....	.....
12	.....	.....	.....	.....	.....	.....	536	329	274	235	204	164	137	117	103	.....	.....	.....	.....	.....	.....	.....	.....	.....
13	.....	.....	.....	.....	.....	.....	710	429	357	306	268	214	178	153	.....	.....	.....	.....	.....	.....	.....	.....	.....	.....
14	.....	.....	.....	.....	.....	.....	876	568	473	406	350	284	236	.....	.....	.....	.....	.....	.....	.....	.....	.....	.....	.....
15	.....	.....	.....	.....	.....	.....	1143	701	584	500	438	350	.....	.....	.....	.....	.....	.....	.....	.....	.....	.....	.....	.....
16	.....	.....	.....	.....	.....	.....	1558	913	761	653	571	.....	.....	.....	.....	.....	.....	.....	.....	.....	.....	.....	.....	.....
17	.....	.....	.....	.....	.....	.....	2069	1246	1038	890	779	.....	.....	.....	.....	.....	.....	.....	.....	.....	.....	.....	.....	.....
18	.....	.....	.....	.....	.....	.....	2758	1655	1379	1182	.....	.....	.....	.....	.....	.....	.....	.....	.....	.....	.....	.....	.....	.....
19	.....	.....	.....	.....	.....	.....	3556	2133	1778	.....	.....	.....	.....	.....	.....	.....	.....	.....	.....	.....	.....	.....	.....	.....
20	.....	.....	.....	.....	.....	.....	5000	3000	.....	.....	.....	.....	.....	.....	.....	.....	.....	.....	.....	.....	.....	.....	.....	.....
21	.....	.....	.....	.....	.....	.....	7111	4444	.....	.....	.....	.....	.....	.....	.....	.....	.....	.....	.....	.....	.....	.....	.....	.....
22	.....	.....	.....	.....	.....	.....	9143	.....	.....	.....	.....	.....	.....	.....	.....	.....	.....	.....	.....	.....	.....	.....	.....	.....

These approximate numbers are an average only, and the figures given may be varied either way by changes in the dimensions of the heads or points. Brads and no-head nails will run more to the pound than the table shows, and large or thick-headed nails will run less.



SIZES, LENGTH, AND NUMBER TO THE POUND OF STANDARD STEEL WIRE NAILS.

(American Steel and Wire Co., 1908.)

Sizes	Length, Inches.	Common Nails and Brads.	Clinch.	Fence.	Smooth and Barbed Finishing.	Fine.	Barrel.	Casing, and Smooth and Barbed Box.	Flooring Brads.	Boat Nails.		Barbed Car Nail.		Slatng.	Barbed Roofng.	Shingle.	Tobacco.	Limg.	Wire Spikes.	Length, Inches.	Sizes.
										Light.	Heavy.	Light.	Heavy.								
3/4	3/4					2077	1346								714			2077		3/4	
7/8	7/8					1781	906								469			1781		7/8	
2d	1	876	710		1351	1558	775	1010							411			155		1	2d
3d fine	1 1/8					1140	700													1 1/8	3d fine
3d common	1 1/4	568	429		807		568	913							225					1 1/4	3d c'm
4d	1 3/8						400	635							230					1 3/8	
5d	1 1/2	316	274		584	760	357	473			82	44			187	176	274			1 1/2	4d
6d	1 3/4	271	235	142	500			406							142	151	235			1 3/4	5d
7d	2	181	157	124	309			236	157		62	32			103	103	204			2	6d
8d	2 1/4	161	139	92	238			210	139		50	26			92	76	139			2 1/4	7d
9d	2 1/2	106	99	82	189			145	99						82	69	125			2 1/2	8d
10d	2 3/4	96	90	62	172			132	90						62	54	114			2 3/4	9d
12d	3	69	69	50	121			94	69		22	14			57	50	69			3	10d
16d	3 1/4	63	62	40	113			87	54						50	42				3 1/4	12d
20d	3 1/2	49	49	30	90			71	43						43	35				3 1/2	16d
30d	4	31	37	23	62			52	31		16	10			31	26				4	20d
40d	4 1/2	24						46							24	24				4 1/2	30d
50d	5	18						35							17	18				5	40d
60d	5 1/2	14													15	15				5 1/2	50d
	6	11													13	13				6	60d

3 3/8 lb. of 4d Common, or 2 3/8 lb. of 3d Common, will lay 1000 shingles.  
 3 1/4 lb. of 3d Fine will put on 1000 laths — 4 nails to the lath.

## WROUGHT SPIKES.

## Number of Nails in Keg of 150 Pounds.

Length, Inches.	1/4 in.	5/16 in.	3/8 in.	Length, Inches.	1/4 in.	5/16 in.	3/8 in.	7/16 in.	1/2 in.
3	2250	.....	.....	7	1161	662	482	445	306
3 1/2	1890	1208	.....	8	.....	635	455	384	256
4	1650	1135	.....	9	.....	573	424	300	240
4 1/2	1464	1064	.....	10	.....	.....	391	270	222
5	1380	930	742	11	.....	.....	.....	249	203
6	1292	868	570	12	.....	.....	.....	236	180

For sizes and weights of wire spikes see Steel Wire Nails, page 235.

## BOAT SPIKES.

## Number in Keg of 200 Pounds.

Length.	1/4	5/16	3/8	1/2
4 inch.....	2375	.....	.....	.....
5 ".....	2050	1230	940	.....
6 ".....	1825	1175	800	450
7 ".....	.....	990	650	375
8 ".....	.....	880	600	335
9 ".....	.....	.....	525	300
10 ".....	.....	.....	475	275

## WIRES OF DIFFERENT METALS AND ALLOYS.

(J. Bucknall Smith's Treatise on Wire.)

**Brass Wire** is commonly composed of an alloy of  $1\frac{3}{4}$  to 2 parts of copper to one part of zinc. The tensile strength ranges from 20 to 40 tons per square inch, increasing with the percentage of zinc in the alloy.

**German or Nickel Silver**, an alloy of copper, zinc, and nickel, is practically brass whitened by the addition of nickel. It has been drawn into wire as fine as 0.002 inch diameter.

**Platinum wire** may be drawn into the finest sizes. On account of its high price its use is practically confined to special scientific instruments and electrical appliances in which resistances to high temperature, oxygen, and acids are essential. It expands less than other metals when heated. Its coefficient of expansion being almost the same as that of glass permits its being sealed in glass without fear of cracking the latter. It is therefore used in incandescent electric lamps.

**Phosphor-bronze Wire** contains from 2 to 6 per cent of tin and from  $\frac{1}{20}$  to  $\frac{1}{8}$  per cent of phosphorus. The presence of phosphorus is detrimental to electric conductivity.

**"Delta-metal"** wire is made from an alloy of copper, iron, and zinc. Its strength ranges from 45 to 62 tons per square inch. It is used for some kinds of wire rope, also for wire gauze. It is not subject to deposits of verdigris. It has great toughness, even when its tensile strength is over 60 tons per square inch.

**Aluminum Wire.**—Specific gravity 2.68. Tensile strength between 10 and 15 tons per square inch. It has been drawn as fine as 11,400 yards to the ounce, or 0.042 grain per yard.

**Aluminum Bronze**, 90 copper, 10 aluminum, has high strength and ductility; is inoxidizable, sonorous. Its electric conductivity is 12.6 per cent. See page 396.

**Silicon Bronze**, patented in 1882 by L. Weiler of Paris, is made as follows: Fluosilicate of potash, pounded glass, chloride of sodium and calcium, carbonate of soda and lime, are heated in a plumbago crucible, and after the reaction takes place the contents are thrown into the molten bronze to be treated. Silicon-bronze wire has a conductivity of from 40 to 98 per cent of that of copper wire and four times more than that of iron, while its tensile strength is nearly that of steel, or

(Continued on page 250.)

PROPERTIES OF STEEL WIRE.

(John A. Roebling's Sons Co., 1908.)

No., Roebling Gauge.	Diam., in.	Area, square inches.	Breaking strain, 100, 000 lb. per sq. inch.	Weight in pounds.		Feet in 2000 lb.
				Per 1000 ft.	Per mile.	
000000	0.460	0.166191	16,619	558.4	2,948	3,582
00000	0.430	0.145221	14,522	487.9	2,576	4,099
0000	0.393	0.121304	12,130	407.6	2,152	4,907
000	0.362	0.102922	10,292	345.8	1,826	5,783
00	0.331	0.086049	8,605	289.1	1,527	6,917
0	0.307	0.074023	7,402	248.7	1,313	8,041
1	0.283	0.062902	6,290	211.4	1,116	9,463
2	0.263	0.054325	5,433	182.5	964	10,957
3	0.244	0.046760	4,676	157.1	830	12,730
4	0.225	0.039761	3,976	133.6	705	14,970
5	0.207	0.033654	3,365	113.1	597	17,687
6	0.192	0.028953	2,895	97.3	514	20,559
7	0.177	0.024606	2,461	82.7	437	24,191
8	0.162	0.020612	2,061	69.3	366	28,878
9	0.148	0.017203	1,720	57.8	305	34,600
10	0.135	0.014314	1,431	48.1	254	41,584
11	0.120	0.011310	1,131	38.0	201	52,631
12	0.105	0.008659	866	29.1	154	68,752
13	0.092	0.006648	665	22.3	118	89,525
14	0.080	0.005027	503	16.9	89.2	118,413
15	0.072	0.004071	407	13.7	72.2	146,198
16	0.063	0.003117	312	10.5	55.3	191,022
17	0.054	0.002290	229	7.70	40.6	259,909
18	0.047	0.001735	174	5.83	30.8	343,112
19	0.041	0.001320	132	4.44	23.4	450,856
20	0.035	0.000962	96	3.23	17.1	618,620
21	0.032	0.000804	80	2.70	14.3	740,193
22	0.028	0.000616	62	2.07	10.9	966,651
23	0.025	0.000491	49	1.65	8.71	...
24	0.023	0.000415	42	1.40	7.37	...
25	0.020	0.000314	31	1.06	5.58	...
26	0.018	0.000254	25	0.855	4.51	...
27	0.017	0.000227	23	.763	4.03	...
28	0.016	0.000201	20	.676	3.57	...
29	0.015	0.000177	18	.594	3.14	...
30	0.014	0.000154	15	.517	2.73	...
31	0.0135	0.000143	14	.481	2.54	...
32	0.013	0.000133	13	.446	2.36	...
33	0.011	0.000095	9.5	.319	1.69	...
34	0.010	0.000079	7.9	.264	1.39	...
35	0.0095	0.000071	7.1	.238	1.26	...
36	0.009	0.000064	6.4	.214	1.13	...

The above table was calculated on a basis of 483.84 lb. per cu. ft. for steel wire. Iron wire is a trifle lighter. The breaking strains are calculated for 100,000 lb. per sq. in. throughout, simply for convenience, so that the breaking strains of wires of any strength per sq. in. may be quickly determined by multiplying the values given in the tables by the ratio between the strength per square inch and 100,000. Thus, a No. 15 wire, with a strength per sq. in. of 150,000 lb., has a breaking strain of  $407 \times \frac{150,000}{100,000} = 610.5$  lb.

28 to 55 tons per square inch of section. The conductivity decreases as the tensile strength increases. Wire whose conductivity equals 95 per cent of that of pure copper gives a tensile strength of 28 tons per square inch, but when its conductivity is 34 per cent of pure copper, its strength is 50 tons per square inch. It is being largely used for telegraph wires. It has great resistance to oxidation.

**Ordinary Drawn and Annealed Copper Wire** has a strength of from 15 to 20 tons per square inch.

### " PLOW " - STEEL WIRE.

Experiments by Dr. Percy on the English plow-steel (so-called) gave the following results: Specific gravity, 7.814; carbon, 0.828 per cent; manganese, 0.587 per cent; silicon, 0.143 per cent; sulphur, 0.009 per cent; phosphorus, nil; copper, 0.030 per cent. No traces of chromium, titanium, or tungsten were found. The breaking strains of the wire were as follows:

Diameter, inch. . . . .	0.093	0.132	0.159	0.191
Pounds per sq. inch.	344,960	257,600	224,000	201,600

The elongation was only from 0.75 to 1.1 per cent.

### STRENGTH OF PIANO-WIRE.

The average strength of English piano-wire is given as follows by Webster, Horsfals & Lean:

Size, Music-wire Gauge.	Equivalent Diameters, Inch.	Ultimate Tensile Strength, Pounds.	Size, Music-wire Gauge.	Equivalent Diameters, Inch.	Ultimate Tensile Strength, Pounds.
12	0.029	225	18	0.041	395
13	.031	250	19	.043	425
14	.033	285	20	.045	500
15	.035	305	21	.047	540
16	.037	340	22	.052	650
17	.039	360			

These strength range from 300,000 to 340,000 lbs. per sq. in. The composition of this wire is as follows: Carbon, 0.570; silicon, 0.090; sulphur, 0.011; phosphorus, 0.018; manganese, 0.425.

### GALVANIZED IRON WIRE FOR TELEGRAPH AND TELEPHONE LINES.

(Trenton Iron Co.)

**WEIGHT PER MILE-OHM.** — This term is to be understood as distinguishing the *resistance of material* only, and means the weight of such material required per mile to give the resistance of one ohm. To ascertain the mileage resistance of any wire, divide the "weight per mile-ohm" by the weight of the wire per mile. Thus in a grade of Extra Best Best, of which the weight per mile-ohm is 5000, the mileage resistance of No. 6 (weight per mile 525 lbs.) would be about 9½ ohms; and No. 14 steel wire, 6500 lbs. weight per mile-ohm (95 lbs. weight per mile), would show about 69 ohms.

#### Sizes of Wire used in Telegraph and Telephone Lines.

No. 4. Has not been much used until recently; is now used on important lines where the multiplex systems are applied.

No. 5. Little used in the United States.

No. 6. Used for important circuits between cities.

No. 8. Medium size for circuits of 400 miles or less.

No. 9. For similar locations to No. 8, but on somewhat shorter circuits; until lately was the size most largely used in this country.

Nos. 10, 11. For shorter circuits, railway telegraphs, private lines, police and fire-alarm lines, etc.

No. 12. For telephone lines, police and fire-alarm lines, etc.



Nos. 13, 14. For telephone lines and short private lines; steel wire is used most generally in these sizes.

The coating of telegraph wire with zinc as a protection against oxidation is now generally admitted to be the most efficacious method.

The grades of line wire are generally known to the trade as "Extra Best Best" (E. B. B.), "Best Best" (B. B.), and "Steel."

"Extra Best Best" is made of the very best iron, as nearly pure as any commercial iron, soft, tough, uniform, and of very high conductivity, its weight per mile-ohm being about 5000 lbs.

The "Best Best" is of iron, showing in mechanical tests almost as good results as the E. B. B., but is not quite as soft, and somewhat lower in conductivity; weight per mile-ohm about 5700 lbs.

The "Steel" wire is well suited for telephone or short telegraph lines, and the weight per mile-ohm is about 6500 lbs.

The following are (approximately) the weights per mile of various sizes of galvanized telegraph wire, drawn by Trenton Iron Co.'s gauge:

No.	4,	5,	6,	7,	8,	9,	10,	11,	12,	13,	14.
Lbs.	720,	610,	525,	450,	375,	310,	250,	200,	160,	125,	95.

**Tests of Telegraph Wire.**

The following data are taken from a table given by Mr. Prescott relating to tests of E. B. B. galvanized wire furnished the Western Union Telegraph Co.

Size of Wire	Diam., Inch.	Weight.		Length. Feet per pound.	Resistance. Temp. 75.8° Fahr.		Ratio of Breaking Weight to Weight per mile.
		Grains per foot.	Pounds per mile.		Feet per ohm	Ohms per mile.	
4	0.238	1043.2	886.6	6.00	958	5.51	
5	.220	891.3	673.0	7.85	727	7.26	
6	.203	758.9	572.2	9.20	618	8.54	3.05
7	.180	596.7	449.9	11.70	578	10.86	3.40
8	.165	501.4	378.1	14.00	409	12.92	3.07
9	.148	403.4	304.2	17.4	328	16.10	3.38
10	.134	330.7	249.4	21.2	269	19.60	3.37
11	.120	265.2	200.0	26.4	216	24.42	2.97
12	.109	218.8	165.0	32.0	179	29.60	3.43
14	.083	126.9	95.7	55.2	104	51.00	3.05

**Sizes, Weights and Strengths of Hard-Copper Telegraph and Telephone Wire.**

(J. A. Roebling's Sons Co., 1908.)

Size B. & S. Gauge.	Diam., in.	Wt., lbs. per mile.	Breaking strain, lbs.	Resistance, International ohms per mile at 75° F.	Approx. size, Roebling gauge of E. B. B. iron wire of equal resistance.	Size B. & S. Gauge.	Diam., in.	Wt., lbs. per mile.	Breaking strain, lbs.	Resistance, International ohms per mile at 75° F.	Approx. size, Roebling gauge of E. B. B. iron wire of equal resistance.
9	0.114	208	653	4.39	2	13	0.072	83	274	11.01	6 1/2
10	0.102	166	540	5.49	3	14	0.064	65	220	13.94	8
11	0.091	132	426	6.90	4	15	0.057	52	174	17.57	9
12	0.081	105	334	8.70	6	16	0.051	42	139	21.95	10

In handling this wire the greatest care should be observed to avoid kinks, bends, scratches or cuts. Joints should be made only with McIntire connectors. On account of its conductivity being about five

times that of E. B. B. iron wire, and its breaking strength over three times its weight per mile, copper may be used of which the section is smaller and the weight less than an equivalent iron wire, allowing a greater number of wires to be strung on the poles. Besides this advantage, the reduction of section materially decreases the electrostatic capacity, while its non-magnetic character lessens the self-induction of the line, both of which features tend to increase the possible speed of signaling in telegraphing, and to give greater clearness of enunciation over telephone lines, especially those of great length.

### Weight of Bare and Insulated Copper Wire, Pounds.

(John A. Roebling's Sons Co., 1908.)

Size B. & S. Gauge.	Weight per 1000 Feet, Solid.					Weight per Mile, Solid.				
	Bare.	Weather-proof.		Fire and Weather Proof.	Slow Burning.	Bare.	Weather-proof.		Fire and Weather Proof.	Slow Burning.
		Double Braid.	Triple Braid.				Double Braid.	Triple Braid.		
0000	641	723	767	862	925	3384	3817	4050	4550	4890
000	509	587	629	710	760	2687	3098	3320	3750	4020
00	403	467	502	562	600	2127	2467	2650	2970	3170
0	320	377	407	462	495	1689	1989	2150	2440	2610
1	253	294	316	340	365	1335	1553	1670	1800	1930
2	202	239	260	280	300	1066	1264	1370	1480	1585
3	159	185	199	230	270	840	977	1050	1220	1425
4	126	151	164	190	220	665	795	865	1000	1160
5	100	122	135	155	190	528	646	710	820	1000
6	79	100	112	127	160	417	529	590	670	840
8	50	66	75	85	110	264	349	395	450	580
9	39	54	62	..	..	206	283	325	..	..
10	32	46	53	60	80	169	241	280	315	420
12	20	30	35	42	55	106	158	185	220	290
14	12.4	20	25	30	40	66	107	130	160	210
16	7.9	16	20	24	30	42	83	105	130	160
18	4.8	12	16	19	24	25	64	85	100	130
20	3.1	9	12	..	..	16	48	65	..	..

### Specifications for Hard-Drawn Copper Wire.

The British Post Office authorities require that hard-drawn copper wire supplied to them shall be of the lengths, sizes, weights, strengths, and conductivities as set forth in the annexed table.

Required Standard.	Weight per Statute Mile, lb.		Approximate Equivalent Diameter, mils.			Minimum Breaking Weight, lb.	Minimum No. of Twists in 3 Inches.	Maximum Resistance per Mile of Wire (when hard) at 60° F., ohms.	Minimum Weight of each Piece of Wire, lbs.
	Minimum.	Maximum.	Standard.	Minimum.	Maximum.				
100	97 1/2	102 1/2	79	78	80	330	30	9.10	50
150	146 1/4	153 3/4	97	95 1/2	98	490	25	6.05	50
200	195	205	112	110 1/2	113 1/4	650	20	4.53	50
400	390	410	158	155 1/2	160 1/4	1300	10	2.27	50

**Stranded Copper Feed Wire, Weight in Pounds.**

(John A. Roebling's Sons Co., 1908.)

Size, Circular Mils.	Weight per 1000 Feet.					Weight per Mile.				
	Bare.	Weather-proof		Fire and Weather Proof.	Slow Burning.	Bare.	Weather-proof		Fire and Weather Proof.	Slow Burning.
		Double Braid.	Triple Braid.				Double Braid.	Triple Braid.		
2,000,000	6100	6690	7008	...	7540	32208	35323	37000	...	39800
1,750,000	5338	5894	6193	...	6700	28184	31119	32700	...	35400
1,500,000	4575	5098	5380	...	5830	24156	26915	28400	...	30800
1,250,000	3813	4264	4508	...	4940	20132	22516	23800	...	20000
1,000,000	3050	3456	3674	3860	3980	16104	18246	19400	20400	26100
900,000	2745	3127	3332	3520	3640	14493	16513	17600	18600	11000
800,000	2440	2799	2992	3180	3280	12883	14779	15800	16800	19200
750,000	2288	2635	2822	3000	3100	12080	13913	14900	15850	17300
700,000	2135	2471	2650	2820	2920	11272	13045	14000	14900	16300
600,000	1830	2093	2235	2330	2460	9662	11052	11800	12400	15400
500,000	1525	1765	1894	1990	2080	8052	9318	10000	10500	13100
450,000	1373	1601	1724	1820	1900	7249	8452	9100	9600	10000
400,000	1220	1436	1553	1650	1700	6441	7584	8200	8700	9000
350,000	1068	1248	1345	1440	1500	5639	6589	7100	7600	7900
300,000	915	1083	1174	1270	1310	4831	5721	6200	6700	6900
250,000	762	907	985	1060	1120	4023	4788	5200	5600	5900
B. & S. Gauge.										
0000	645	745	800	900	960	3405	3935	4220	4750	5070
000	513	604	653	735	785	2708	3190	3450	3880	4150
00	406	482	522	583	625	2143	2544	2760	3080	3300
0	322	388	424	480	510	1700	2051	2240	2530	2700
1	255	303	328	355	380	1346	1599	1735	1870	2000
2	203	246	270	290	335	1071	1301	1425	1540	1770
3	160	190	206	240	280	844	1004	1090	1270	1480
4	127	155	170	195	230	670	820	900	1030	1220
5	101	126	140	160	195	533	668	740	845	1030
6	80	103	115	132	165	422	544	610	695	870
8	50	68	78	87	105	264	359	410	460	555

**WIRE ROPE.**

The following notes and tables are compiled from data furnished by the American Steel & Wire Co., Cleveland, 1915.

Wire ropes, which have almost entirely superseded chains and manila rope for haulage and hoisting purposes, are made with a varying number of wires to the strand, and a varying number of strands to the rope, according to the service in which they are to be used and the degree of flexibility required. Five grades of rope are usually manufactured, as regards the material used, viz.: Iron, crucible cast steel, extra strong crucible cast steel, "plow-steel," and an improved grade of plow-steel called "Monitor." Haulage rope, for mines, docks, etc., usually consists of 6 strands of 7 wires each laid around a hemp core. Hoisting rope, for elevators, mines, coal and ore hoists, conveyors, derricks, steam shovels, dredges, logging, etc., consists of 6 strands of 19 wires each, with a single hemp core. A more flexible rope, for crane service, etc., consists of 6 37-wire strands wound around a single hemp core. In general, the flexibility of the rope is increased by increasing the number of wires in the strands. The most flexible



standard rope made consists of 6 61-wire strands and one hemp core. Other varieties comprise flattened strand ropes for haulage, hoisting, and transmission, non-spinning rope for the suspension of loads at the end of a single line, steel clad rope for severe conditions of service, guy and rigging ropes, and hawsers for towing or mooring.

**Breaking Strength of Wire Rope.**—The various manufacturers have adopted standard figures for the strength of all sizes and qualities of wire rope. Formerly, it was the custom to test the individual wires and to consider their combined strength as the strength of the rope as a whole. These strengths were greater than the actual strength obtained by breaking the finished rope. The figures given in the tables herewith represent actual breaks of the various ropes, and range from 95 to 80 per cent or less of the combined strength of the single wires, depending on the construction. The figures, which were adopted May 1, 1910, are considerably lower than those given in earlier tables. In general, a factor of safety of five is allowed in giving the working loads.

**Lay of Wire Rope.**—**Lang Lay.**—The regular lay of wire rope comprises wires in the strands laid to the left, the strands being laid to the right, known as right-hand rope; or wires laid to the right, and strands laid to the left, known as left-hand rope. In Lang lay rope the wires in the strands and the strands themselves are laid in the rope in the same direction, either right or left. Lang lay rope is somewhat more flexible than ordinary rope, and as the wires are laid more axially in the rope, longer surfaces are exposed to wear, and the endurance is thereby increased.

**Sheaves and Drums.**—Drums and sheaves of the largest practicable diameter are recommended in all wire rope installations. If possible, drums should be lagged, and where feasible, a grooved drum on hoists is more desirable than a flat drum. The grooves should give ample clearance between successive windings; thus a drum for  $\frac{3}{4}$ -inch rope should have the grooves at least  $\frac{7}{8}$ -inch apart on centers. The grooves should be made smooth in order not to cut the rope, and they should be of slightly larger radius than the rope in order to avoid wedging or pinching it. Overwinding, that is, the winding of the rope in more than one layer, is to be avoided if possible, by making the drum large enough to take all the rope in a single layer. Overwinding will rapidly destroy the rope, and the extra cost of the larger drum will be more than compensated by the greater life of the rope. The best possible alignment of sheaves and drums should be made to avoid undue wear on the sides of the sheaves and the rope. In general, the lead sheaves over which the rope runs from the drum should be aligned with the center of the drum, or if the drum is not entirely filled, with the center of the portion on which the rope is wound. The distance between the drum and lead sheave should be such as to cause an angle not exceeding  $1^{\circ} 30'$  between the line from the center of the sheave to the center of the drum, and the line from the center of the sheave to the outer side of the drum. When the sheaves become worn, they should be replaced or the grooves turned before they are used with a new wire rope, otherwise the rope will not work properly. For many purposes, particularly mine service, the grooves can advantageously be lined with well-seasoned, hardwood blocks set on end, which can be renewed when worn. Large sheaves, running at high velocity, should be lined with leather set on end, or with india-rubber. This is the practice for power transmission between distant points, where the rope frequently runs at a velocity of 4,000 feet per minute.

**Reversed Bending.**—Reverse bending, that is, bending the wire rope first in one direction over sheaves and then in the opposite direction, is to be avoided wherever possible. This practice will wear out a rope more quickly than any other known method. A little care in design will usually eliminate all situations which call for reversed bending, and it is even desirable to change existing constructions if necessary to remove this condition. The expense of rope renewals will more than equal the cost of change as a rule.

**Handling Wire Rope.**—Wire rope must not be coiled or uncoiled like hemp rope. When received in a coil it should be rolled on the ground like a hoop and straightened out before being put on the sheaves. If on a reel, it should be mounted on a spindle or a flat



**Galvanized Iron and Steel Wire Rope.**

For Ship and Yacht Rigging, Guys, etc.

6 Strands, 7 or 12 Wires per Strand, 1 Hemp Core; 6 Strands, 19 Wires per Strand, 1 Hemp Core.

Diameter, In.	Approx. Circum., In.	Wt. per Ft., Lb.	7 or 12-Wire Strand, Iron		19-Wire Strand, Steel		Diameter, In.	Approx. Circum., In.	Wt. per Ft., Lb.	7 or 12-Wire Strand, Iron.		19-Wire Strand, Steel	
			Approx. Strength, Tons (2000 Lb.).	Circum. of Manila Rope of Equal Strength, In.	Approx. Strength, Tons (2000 Lb.).	Circum. of Manila Rope of Equal Strength, In.				Approx. Strength, Tons (2000 Lb.).	Circum. of Manila Rope of Equal Strength, In.	Approx. Strength, Tons (2000 Lb.).	Circum. of Manila Rope of Equal Strength, In.
1 3/4	51 1/2	4.85	42.0	11.0	...	...	13/16	21 1/2	1.03	9.4	5	19.0	8.0
1 11/16	51 1/4	4.42	38.0	10.5	...	...	3/4	21 1/4	0.89	7.8	4.75	16.8	7.0
1 5/8	5	4.15	35.0	10.0	...	...	5/8	2	0.62	5.7	4.5	11.7	5.0
1 1/2	43 3/4	3.55	30.0	9.5	...	...	9/16	13 3/4	0.50	4.46	3.75	9.0	5.25
1 7/16	41 1/2	3.24	28.0	9.0	...	...	1/2	11 1/2	0.39	3.39	3	7.0	4.75
1 3/8	41 1/4	3.00	26.0	8.5	...	...	7/16	11 1/4	0.30	2.35	2.5	5.0	4.25
1 1/4	4	2.45	23.0	8.0	42.0	13	3/8	11 1/8	0.22	1.95	2.25	4.2	3.75
1 3/16	33 3/4	2.21	19.0	7.5	38.0	12	5/16	1	0.15	1.42	2	3.2	3.0
1 1/8	31 1/2	2.00	18.0	6.5	34.0	11	9/32	7 7/8	0.125	1.20	1.75	...	...
1 1/16	31 1/4	1.77	16.1	6.0	31.0	10	1/4	3 3/4	0.09	0.99	1.5	...	...
1	3	1.58	14.1	5.75	28.0	9	7/32	5 5/8	0.063	0.79	1.25	...	...
7/8	23 3/4	1.20	11.1	5.25	22.0	8.5	3/16	1 1/2	0.04	0.61	1.125	...	...

**Galvanized Steel Wire Strand.**

7 or 19 Wires Twisted into a Single Strand.

Diam., In.	Wt. per 1000 Ft., Lbs.	Breaking Stress, Lbs.	Diam., In.	Wt. per 1000 Ft., Lbs.	Breaking Stress, Lbs.	Diam., In.	Wt. per 1000 Ft., Lbs.	Breaking Stress, Lbs.	Diam., In.	Wt. per 1000 Ft., Lbs.	Breaking Stress, Lbs.
1	2100	32000	9/16	650	11000	5/16	210	3800	5/32	55	900
7/8	1610	24000	1/2	510	8500	1/4	125	2300	1/8	32	500
3/4	1200	18000	7/16	415	6500	7/32	95	1800	3/32	20	400
5/8	800	14000	3/8	295	5000	3/16	75	1400	...	...	...

19-wire strand is made only from 1 to 1/2 in. diam., 7-wire strand is made only from 3/4 to 3/32 in. diam.

**Galvanized Steel Cables for Suspension Bridges.**

Composed of 6 Strands—with Wire Center.

Diam., In.	Wt. per Foot, Lb.	Approx. Breaking Strain, Tons (2000 Lb.).	Diam., In.	Wt. per Foot, Lb.	Approx. Breaking Strain, Tons.	Diam., In.	Wt. per Foot, Lb.	Approx. Breaking Strain, Tons.
2 3/4	12.7	310	2 1/4	8.52	208	1 3/4	5.10	124
2 5/8	11.6	283	2 1/8	7.60	185	1 5/8	4.34	106
2 1/2	10.5	256	2	6.73	164	1 1/2	3.70	90
2 3/8	9.50	232	1 7/8	5.90	144	1 3/8	3.10	75

turntable and properly unwound. Kinking or untwisting must be avoided.

**Protection of Wire Rope.**—Wire rope should be protected by a suitable lubricant, both internally and externally, to prevent rust and to keep it pliable. If this is omitted rust will set in and stiffen the rope, resulting in poor service. Raw linseed oil, applied with a piece of sheepskin, the wool inside, is a good preservative; the oil also may be mixed with Spanish brown or lamp-black. Wire rope running under water should be treated with mineral or vegetable tar, one bushel of fresh slacked lime being added to each barrel of tar to neutralize the acid. The tar is well boiled and the rope saturated with it. Wire rope manufacturers furnish special compounds for the treatment of wire ropes.

**Exposure to Heat.**—Where wire rope is exposed to intense heat, as in foundry or steel mill service, a soft iron core is often substituted for the hemp core. Asbestos also is sometimes used, but it rapidly disintegrates and is not recommended. The use of the iron core adds from 7 to 10 per cent to the strength of the rope, but the wear on the center is as great as on the outside strands, and the hemp center is to be preferred wherever possible.

### VARIETIES AND USES OF WIRE ROPE.

**Transmission, Haulage or Standing Rope.**—Usually made of 6 7-wire strands and one hemp core, in all five grades noted above. Iron rope is comparatively little used except in the smaller sizes. It is composed of very soft wires of low tensile strength. Crucible cast steel rope is particularly adapted to mine haulage work, including tail rope and endless haulage systems, gravity hoists, and coal and ore dock haulage, roads operating small grip cars. The sizes,  $\frac{3}{8}$  to  $\frac{5}{8}$  inch inclusive, are used for sand lines in oil wells, and from  $\frac{5}{8}$  to 1 inch for oil-well drilling. In general it can be used for severe service, and where the flexibility required is a minimum. Extra strong crucible cast steel rope has practically the same applications as the preceding rope, except that being stronger a smaller rope can be used for the same service. The plow-steel rope is advised for situations similar to those for which the cast steel ropes are used, but where it is necessary to secure increased strength, without altering the working conditions. The wires are harder and capable of standing greater wear than any of the foregoing ropes. Monitor plow-steel rope is the strongest and stiffest of all and is used for work demanding the greatest strength and lightest rope possible. Sheaves for this rope should, if possible, be somewhat larger than for other grades. For working loads, strength, etc., of these ropes, see table, page 257.

**Standard Hoisting Rope.**—Composed of 6 19-wire strands and a hemp core; made in the following grades: Iron, mild steel, crucible cast steel, extra strong crucible cast steel, plow-steel, and Monitor plow-steel. The wires are smaller than those in transmission ropes of the same size, and it is more flexible. It will not stand as much abrasion as transmission rope. The iron rope is used for elevator hoisting, where the strength is sufficient, and is almost universally employed for counterweights, except on traction elevators. Where the pulleys are comparatively small it is sometimes used for power transmission. The mild steel rope is made especially for traction elevators, where quick starting and stopping is required. The crucible cast steel rope is adapted to mine hoisting, logging, elevators, derricks, hay presses, dredges, cableways, inclined planes, coal hoists, conveyors, ballast unloaders, ship hoists, and similar applications. The extra strong crucible cast steel rope is adapted to the same purposes and may be used for heavier loads than the former rope. It is extensively used for oil-well drilling and tubing lines. Plow-steel rope is used for heavy mine work, inclined planes, dredges, cableways, for heavy logging, etc. It is especially desirable for deep mine shafts and long inclines on account of its great strength per unit of weight. It is the most economical rope where the weight of the rope is to be considered or the capacity of the machinery is to be increased without changing sheaves or drums. Monitor plow-steel rope is somewhat

**Transmission, Haulage, or Standing Rope.**  
6 Strands, 7 Wires per Strand, 1 Hemp Core.

Diameter, In.	Approx. Circum. In.	Approx. Weight per Ft., Lb.	Approximate Breaking Strength, Tons (2000 lbs.)					Allowable Working Load, Tons (2000 lbs.)					Min. Dia. Drum or Sheave, In.	
			Iron.	Crucible Cast Steel.	Extra Strong Crucible Cast Steel.	Plow Steel.	Monitor Plow Steel.	Iron.	Crucible Cast Steel.	Extra Strong Crucible Cast Steel.	Plow Steel.	Monitor Plow Steel.	Iron Rope.	Steel Rope.
1 1/2	4 3/4	3.55	32.0	63.0	73.0	82.0	90.0	6.4	12.6	14.6	16.4	18.0	16.0	11.0
1 3/8	4 1/4	3.00	28.0	53.0	63.0	72.0	79.0	5.6	10.6	12.6	14.4	16.0	15.0	10.0
1 1/4	4	2.45	23.0	46.0	54.0	60.0	67.0	4.6	9.2	10.8	12.0	13.0	13.0	9.0
1 1/8	3 1/2	2.00	19.0	37.0	43.0	47.0	52.0	3.8	7.4	8.6	9.4	10.0	1.20	8.0
7/8	3	1.58	15.0	31.0	35.0	38.0	42.0	3.0	6.2	7.0	7.6	8.4	10.5	7.0
3/4	2 3/4	1.20	12.0	24.0	28.0	31.0	33.0	2.4	4.8	5.6	6.2	6.6	9.0	6.0
5/8	2 1/4	0.89	8.8	18.6	21.0	23.0	25.0	1.7	3.7	4.2	4.6	5.0	7.5	5.0
9/16	2 1/8	0.75	7.3	15.4	16.7	18.0	20.0	1.5	3.1	3.3	3.6	4.0	7.25	4.75
11/16	1 3/4	0.50	4.8	10.0	11.0	12.0	13.0	0.96	2.0	2.2	2.4	2.6	6.0	4.00
1/2	1 1/2	0.39	3.7	7.7	8.85	10.0	11.0	0.74	1.5	1.8	2.0	2.2	5.5	3.50
7/16	1 1/4	0.30	2.6	5.5	6.25	7.0	7.75	0.52	1.1	1.25	1.4	1.5	4.5	3.00
3/8	1 1/8	0.22	2.2	4.6	5.25	5.9	6.5	0.44	0.92	1.05	1.2	1.3	4.0	2.75
5/16	1	0.15	1.7	3.5	3.95	4.4	.....	0.34	0.70	0.79	0.88	.....	3.5	2.25
9/32	7/8	0.125	1.2	2.5	2.95	3.4	.....	0.24	0.50	0.59	0.68	.....	3.0	1.75

**Standard Hoisting Rope.**

6 Strands, 19 Wires per Strand, 1 Hemp Core.

Diameter, In.	Approx. Circum. In.	Approx. Weight per Ft., Lb.	Approximate Breaking Strength, Tons (2000 Lbs.)					Allowable Working Loads, Tons (2000 Lbs.)					Min. Dia. Sheave or Drum, Ft.	
			Iron.	Crucible Cast Steel.	Extra Strong Crucible Cast Steel.	Plow Steel.	Monitor Plow Steel.	Iron.	Crucible Cast Steel.	Extra Strong Crucible Cast Steel.	Plow Steel.	Monitor Plow Steel.	Iron Rope.	Steel Rope.
2 3/4	8 5/8	11.95	111.0	211.0	243.0	275.0	315.0	22.2	42.2	48.6	55.0	63.0	17.0	11.0
2 1/2	7 7/8	9.85	92.0	170.0	200.0	229.0	263.0	18.4	34.0	40.0	46.0	53.0	15.0	10.0
2 1/4	7 1/8	8.00	72.0	133.0	160.0	186.0	210.0	14.4	26.6	32.0	37.0	42.0	14.0	9.0
2	6 1/4	6.30	55.0	106.0	123.0	140.0	166.0	11.0	21.2	24.6	28.0	33.0	12.0	8.0
1 7/8	5 3/4	5.55	50.0	96.0	112.0	127.0	150.0	10.0	19.0	22.4	25.0	30.0	12.0	8.0
1 3/4	5 1/2	4.85	44.0	85.0	99.0	112.0	133.0	8.8	17.0	19.8	22.0	27.0	11.0	7.0
1 5/8	5	4.15	38.0	72.0	83.0	94.0	110.0	7.6	14.4	16.6	19.0	22.0	10.0	6.5
1 1/2	4 3/4	3.55	33.0	64.0	73.0	82.0	98.0	6.6	12.8	14.6	16.0	20.0	9.0	6.0
1 3/8	4 1/4	3.00	28.0	56.0	64.0	72.0	84.0	5.6	11.2	12.8	14.0	17.0	8.5	5.5
1 1/4	4	2.45	22.8	47.0	53.0	58.0	69.0	4.56	9.4	10.6	12.0	14.0	7.5	5.0
1 1/8	3 1/2	2.00	18.6	38.0	43.0	47.0	56.0	3.72	7.6	8.6	9.4	11.0	7.0	4.5
7/8	3	1.58	14.5	30.0	34.0	38.0	45.0	2.90	6.0	6.80	7.6	9.0	6.0	4.0
3/4	2 3/4	1.20	11.8	23.0	26.0	29.0	35.0	2.36	4.6	5.20	5.8	7.0	5.5	3.5
5/8	2 1/4	0.89	8.5	17.5	20.2	23.0	26.3	1.70	3.5	4.04	4.6	5.3	4.5	3.0
9/16	2	0.62	6.0	12.5	14.0	15.5	19.0	1.20	2.5	2.80	3.1	3.8	4.0	2.5
1/2	1 3/4	0.50	4.7	10.0	11.2	12.3	14.5	0.94	2.0	2.24	2.4	2.9	3.5	2.25
7/16	1 1/2	0.39	3.9	8.4	9.2	10.0	12.1	0.78	1.68	1.84	2.0	2.4	3.0	2.0
3/8	1 1/4	0.30	2.9	6.5	7.25	8.0	9.4	0.58	1.30	1.45	1.6	1.9	2.75	1.75
5/16	1 1/8	0.22	2.4	4.8	5.30	5.75	6.75	0.48	0.96	1.06	1.15	1.35	2.25	1.50
1/4	3/4	0.10	1.1	2.2	2.43	2.65	3.15	0.22	0.44	0.49	0.53	0.63	1.5	1.00



stiffer than the same diameter of crucible and plow-steel ropes, but strength for strength, it is equally flexible. A smaller rope of this grade than any of the others can be used for a given service. It is particularly adapted to derricks, dredges, skidders, and stump pullers. The sheaves should be somewhat larger, if possible, than for the other grades. See tables, page 257.

**Extra Flexible Hoisting Rope.**—Consists of 8 19-wire strands and one hemp core. The greater flexibility permits its use on smaller sheaves and drums, such as are usually found on derricks. It is not advisable to use it where there is much overwinding, as it will flatten much more quickly than the  $6 \times 19$  standard rope. It is made in the five grades of iron, crucible cast steel, extra strong crucible cast steel, plow-steel, and Monitor plow-steel. Its uses are the same as those of standard hoisting rope, noted above. See tables, page 259.

**Special Flexible Hoisting Rope.**—Consists of 6 37-wire strands and one hemp core. It is extremely flexible, and is especially adapted to service on cranes where the sheaves are rather small. It is made in the grades crucible cast steel, extra strong crucible cast steel, plow-steel, and Monitor plow-steel. It will not stand as much abrasion as the 6 19-wire strand rope, but it is particularly efficient, as over 50 per cent of the wires are in the inner layers and are protected from abrasion. The crucible steel ropes are used for general hoisting work where the sheaves are small, while the plow-steel varieties are recommended for crane service. The Monitor plow-steel rope is largely used on dredges for both main and spud ropes. See table, page 259.

**Flattened Strand Rope.**—Flattened strand ropes are used where an increased wearing surface is desired above that obtained with a round strand rope. They are made both for haulage and transmission, and for hoisting, and are always made Lang lay.

The haulage rope is made in three types, each of which has one hemp core. The first has 5 9-wire strands, the center wire being of elliptical section; the second has 6 8-wire strands, the center wire being of triangular section; the third has 5 11-wire strands, the three center wires being of smaller diameter than the others and laid alongside of each other in the same plane. These ropes are made in the iron, crucible cast steel, extra strong crucible cast steel, and Monitor plow-steel grades. They are made in diameters ranging from  $1\frac{1}{2}$  inch, down to  $\frac{3}{8}$  inch. The 1-inch 6 8-wire strand rope weighs 1.80 lb. per ft. and has an approximate strength of 34 tons, in the crucible cast steel grade. Monitor plow-steel rope of the same diameter and weight has an approximate breaking strength of 36 tons. The similar figures for  $\frac{1}{2}$ -inch rope, weighing 0.45 lb. per ft., are: Crucible cast steel, 9.6 tons; Monitor plow-steel, 11.9 tons.

Flattened strand hoisting rope is made in two types, each with one hemp core: (A) 5 28-wire strands, the center wire being of elliptical section; and (B) 6 25-wire strands, the center wire being of triangular section, and the 12 wires immediately surrounding it being of smaller diameter than the outer wires. These ropes compare in flexibility with the standard hoisting ropes, but have about 150 per cent greater wearing surface. Type A is made in the grades of iron, crucible cast steel, extra strong crucible cast steel, and Monitor plow steel. Type B is made in the grades of crucible cast steel, extra strong crucible cast steel, and Monitor plow steel. They are made in sizes ranging from  $2\frac{1}{4}$  in. diam. down to  $\frac{3}{8}$  inch. Type B rope, 2 in. diam., weighing 7.25 lb. per ft., has the following breaking strength: Crucible cast steel, 117 tons; Monitor plow steel, 183 tons. The similar figures for  $\frac{1}{2}$ -inch rope of the same type, weighing 0.45 lb. per ft., are: Crucible cast steel, 9.3 tons; Monitor plow steel, 13.3 tons.

**Non-Spinning Hoisting Rope.**—Comprises 18 7-wire strands and one hemp core, 6 strands, long lay, being laid around the core to the left, and 12 strands, regular lay being laid to the right around them. A free object suspended from the end of a rope of this character will not rotate and endanger the lives of persons below it. Furthermore, the attention required to handle and guide the load is decreased. This rope is recommended for back haul or single-line derricks, and for shaft sinking and mine hoisting, where the bucket swings without guides. This rope works best where it does not overwind on the



**Extra Flexible Steel Hoisting Rope.**

8 Strands, 19 Wires per Strand, 1 Hemp Core.

Diameter, In.	Approx. Circum., In.	Wt. per Ft., Lb.	Approximate Strength, Tons (2000 Lbs.).				Allowable Working Load, Tons (2000 Lbs.).				Min. Diam. of Drum or Sheave, Ft.
			Crucible Cast Steel Rope.	Extra Strong Crucible Cast Steel Rope.	Plow Steel Rope.	Monitor Plow Steel Rope.	Crucible Cast Steel Rope.	Extra Strong Crucible Cast Steel Rope.	Plow Steel Rope.	Monitor Steel Rope.	
1 1/2	4 3/4	3.19	58.0	66.0	74.0	80.0	11.6	13.0	14.8	16.0	3.75
1 3/8	4 1/4	2.70	51.0	57.0	64.0	68.0	10.2	11.0	12.8	13.0	3.50
1 1/4	4	2.20	42.0	47.0	52.0	56.0	8.4	9.4	10.4	11.0	3.20
1 1/8	3 1/2	1.80	34.0	38.0	43.0	46.0	6.8	7.6	8.6	9.2	2.83
1	3	1.42	26.0	29.7	33.0	36.0	5.2	5.9	6.6	7.2	2.50
7/8	2 3/4	1.08	20.0	23.0	26.0	28.0	4.0	4.6	5.2	5.6	2.16
3/4	2 1/4	0.80	15.3	17.6	20.0	22.0	3.06	3.5	4.0	4.4	1.83
5/8	2	0.56	10.9	12.4	14.0	15.0	2.18	2.5	2.8	3.0	1.75
9/16	1 3/4	0.45	8.7	10.1	11.6	12.0	1.74	2.0	2.32	2.4	1.50
1/2	1 1/2	0.35	7.3	8.0	8.7	9.5	1.46	1.6	1.74	1.9	1.33
7/16	1 1/4	0.27	5.7	6.30	6.90	...	1.14	1.26	1.38	...	1.16
3/8	1 1/8	0.20	4.2	4.66	5.12	...	0.84	0.93	1.02	...	1.00
5/16	1	0.13	2.75	3.05	3.35	...	0.55	0.61	0.67	...	0.83
1/4	3/4	0.09	1.80	2.02	2.25	...	0.36	0.40	0.45	...	0.75

**Special Flexible Steel Hoisting Rope.**

6 Strands, 37 Wires per Strand, 1 Hemp Core.

Diameter, In.	Approx. Circum., In.	Approx. Wt. per Ft., Lbs.	Breaking Strength, Tons (2000 Lbs.).				Allowable Working Load, Tons (2000 Lbs.).				Min. Diam. of Drum or Sheave, Ft.
			Crucible Cast Steel Rope.	Extra Strong Crucible Cast Steel Rope.	Plow Steel Rope.	Monitor Plow Steel Rope.	Crucible Cast Steel Rope.	Extra Strong Crucible Cast Steel Rope.	Plow Steel Rope.	Monitor Plow Steel Rope.	
2 3/4	8 5/8	11.95	200.0	233.0	265.0	278.0	40.0	47.0	53.0	55.0	....
2 1/2	7 7/8	9.85	160.0	187.0	214.0	225.0	32.0	37.0	43.0	45.0	....
2 1/4	7 1/8	8.00	125.0	150.0	175.0	184.0	25.0	30.0	35.0	37.0	....
2	6 1/4	6.30	105.0	117.0	130.0	137.0	21.0	23.0	26.0	27.0	....
1 7/8	5 3/4	5.55	94.0	106.0	119.0	125.0	18.8	21.2	23.8	25.0	....
1 3/4	5 1/2	4.85	84.0	95.0	108.0	113.0	17.0	19.0	22.0	23.0	....
1 5/8	5	4.15	71.0	79.0	90.0	95.0	14.0	16.0	18.0	19.0	....
1 1/2	4 3/4	3.55	63.0	71.0	80.0	84.0	12.0	14.0	16.0	17.0	3.75
1 3/8	4 1/4	3.00	55.0	61.0	68.0	71.0	11.0	12.0	14.0	14.0	3.50
1 1/4	4	2.45	45.0	50.0	55.0	58.0	9.0	10.0	11.0	11.0	3.20
1 1/8	3 1/2	2.00	34.0	39.0	44.0	46.0	7.0	8.0	9.0	9.2	2.83
1	3	1.58	29.0	32.0	35.0	37.0	6.0	6.4	7.0	7.4	2.50
7/8	2 3/4	1.20	23.0	25.0	27.0	29.0	5.0	5.0	5.0	5.8	2.16
3/4	2 1/4	0.89	17.5	19.0	21.0	23.0	3.5	3.8	4.0	4.6	1.83
5/8	2	0.62	11.2	12.6	14.0	16.0	2.2	2.5	3.0	3.2	1.75
9/16	1 3/4	0.50	9.5	10.5	11.5	12.5	1.9	2.1	2.3	2.5	1.50
1/2	1 1/2	0.39	7.25	8.25	9.25	9.75	1.45	1.65	1.85	1.9	1.33
7/16	1 1/4	0.30	5.5	6.35	7.2	7.50	1.1	1.27	1.4	1.5	1.15
3/8	1 1/8	0.22	4.2	4.65	5.1	5.30	0.84	0.93	1.0	1.06	1.00

drum. The best fastening is an open or closed socket, but the wire rope makers recommend that fastenings be attached at the factory. This rope should not be as heavily loaded as ordinary hoisting rope. It is made in the grades of iron, crucible cast steel, extra strong crucible cast steel, plow steel, and Monitor plow steel. See table, page 261.

### Extra Flexible Iron Hoisting Rope.

8 Strands, 19 Wires per Strand, 1 Hemp Core.

Diam. In. ....	1	7/8	3/4	5/8	9/16	1/2
Approx. Circum., in. ....	3	2 3/4	2 1/4	2	1 3/4	1 1/2
Weight per ft., lb. ....	1.42	1.08	0.80	0.56	0.45	0.35
Approximate Strength, tons (2000 lbs.) .....	16.0	13.0	9.5	7.0	6.0	5.0
Working Load, tons (2000 lbs.)	3.1	2.6	1.9	1.4	1.2	1.0
Min. Diam of Drum, ft. ....	6.0	5.5	4.5	4.0	3.5	3.0

**Steel-Clad Hoisting Rope.**—The regular grades of hoisting ropes, as well as the special flexible and extra flexible, are furnished, if desired, with a flat strip of steel wound spirally around each strand. These give additional wearing surface without sacrificing the flexibility. When the flat winding is worn through, a complete rope remains with unimpaired strength. These ropes are designed for severe conditions of service, and an additional service of 50 to 100 per cent over that of the unprotected rope is frequently obtained. The hoisting rope tables on pages 257 and 259 may be used for the strength of steel-clad rope, by referring to the diameter of the rope, as it would be were no wrapping applied. The steel wrapping is not considered as adding any strength to the rope, but merely serving to increase its life.

**Flat Rope.**—Flat rope consists of a number of "flat-rope" strands, twisted alternately right and left, placed side by side and served with soft Swedish iron or steel wire, to form a flat rope of the desired width and thickness. The soft sewing wires wear much quicker than the rope wire, and have to be replaced from time to time, at which time worn strands can also be renewed. Flat rope is used principally for hoisting heavy loads out of deep shafts, it requiring a reel but little larger than the width of the rope, whereas round rope necessitates the use of a large drum. Its use is recommended where saving of machinery space is an object. It does not twist or spin in the shaft. It is also used for operating spouts on coal and ore docks, and for raising and lowering emergency gates on canals and similar machinery. For details of methods of fastening it to drums, the manufacturers should be consulted. Drums and sheaves should be as large as possible. A rule for the diameter of the drum is  $D = ct$ , where  $D$  is diameter of drum at bottom; ft.,  $t$  = thickness of rope; in. and  $c = 100$  for drums and 160 for sheaves. Sheaves should be crowned at the center and have deep flanges to guide the rope. See table, page 261.

**Track Cable for Aerial Tramways.**—Composed of several successive layers of wires wrapped around a single wire core, the number of wires varying with the diameter of the cable. The cable is made in plow steel and crucible steel grades.

### Track Cable for Aerial Tramways.

Diam., In.	No. of Wires.	Wt. per Ft., Lbs.	Breaking Stress Tons (2000 Lbs.).		Diam., In.	No. of Wires.	Wt. per Ft., Lb.	Breaking Stress Tons (2000 Lbs.).		Diam., In.	No. of Wires.	Wt. per Ft., Lb.	Breaking St'ss Tons (2000 Lbs.)	
			Crucible Steel.	Plow Steel.				Crucible Steel.	Plow Steel.				Crucib. Steel.	Plow Steel.
2 1/2	91	1310	285.0	335.0	1 3/4	61	659	145.8	171.0	1 1/8	37	270	60.0	70.0
2 1/4	91	1036	233.0	266.0	1 5/8	61	563	124.0	146.0	1	19	220	49.2	58.7
2 1/8	91	935	204.0	240.0	1 1/2	37	488	108.4	127.5	7/8	19	169	37.6	44.4
2	61	840	185.0	218.0	1 3/8	37	401	88.8	105.0	3/4	19	124	27.6	32.5
1 7/8	61	728	161.0	189.0	1 1/4	37	323	71.8	84.6	5/8	19	86	19.2	22.3

**Non-Spinning Hoisting Rope.**

18 Strands, 7 Wires per Strand, 1 Hemp Core.

Diameter, In.	Approx. Circum., In.	Wt. per Ft., Lb.	Approximate Breaking Strength, Tons (2000 Lb.).					Allowable Working Load, Tons (2000 Lb.).					Min. Diameter of Drum or Sheave, Ft.
			Iron Rope.	Crucible Cast Steel Rope.	Extra Strong Crucible Cast Steel Rope.	Plow Steel Rope.	Monitor Plow Steel Rope.	Iron Rope.	Crucible Cast Steel Rope.	Extra Strong Crucible Cast Steel Rope.	Plow Steel Rope.	Monitor Plow Steel Rope.	
1 3/4	5 1/2	5.50	45.80	85.90	101.00	111.10	122.00	9.1	17.1	20.2	22.2	24.04	7.00
1 5/8	5	4.90	39.80	74.40	87.60	96.30	.....	7.9	14.8	17.5	19.2	.....	6.50
1 1/2	4 3/4	4.32	34.00	63.80	75.00	82.50	90.70	6.8	12.7	15.0	16.5	18.1	6.00
1 3/8	4 1/4	3.60	28.20	52.00	62.40	68.60	75.50	5.6	10.4	12.4	13.7	15.1	5.50
1 1/4	4	2.80	23.40	43.80	51.60	56.80	62.50	4.6	8.7	10.3	11.3	12.5	5.00
1 1/8	3 1/2	2.34	19.60	36.80	43.20	47.50	52.20	3.9	7.3	8.6	9.5	10.4	4.50
1	3	1.73	14.95	28.00	33.00	36.30	39.00	2.9	5.6	6.6	7.2	7.8	4.00
7/8	2 3/4	1.44	11.95	22.50	26.50	31.80	35.00	2.3	4.5	5.3	6.3	7.0	3.50
3/4	2 1/4	1.02	8.85	16.70	19.60	24.60	27.00	1.7	3.3	3.9	4.9	5.4	3.00
5/8	2	0.70	5.90	11.10	13.10	15.75	17.30	1.1	2.2	2.6	3.1	3.4	2.50
9/16	1 3/4	0.57	4.85	9.10	10.70	12.80	.....	0.97	1.8	2.1	2.5	.....	2.25
1/2	1 1/2	0.42	3.65	6.90	8.10	9.75	10.70	0.73	1.3	1.6	1.9	2.1	2.00
7/16	1 1/4	0.31	2.63	4.90	5.80	6.85	.....	0.52	0.98	1.1	1.3	.....	1.75
3/8	1 1/8	0.25	2.10	3.90	4.60	5.55	6.10	0.42	0.78	0.92	1.1	1.2	1.50

**Steel Flat Rope.**

Thickness, In.	Width, In.	Allowable Working Load, Tons (2000 Lbs.).			Thickness, In.	Width, In.	Allowable Working Load, Tons (2000 Lbs.).			Thickness, In.	Width, In.	Allowable Working Load, Tons (2000 Lbs.).		
		Wt. per Ft., Lbs.	Crucible Steel.	Plow Steel.			Wt. per Ft., Lbs.	Crucible Steel.	Plow Steel.			Wt. per Ft., Lbs.	Crucible Steel.	Plow Steel.
1/4	1 1/2	0.65	2.6	3.10	3/8	4 1/2	2.85	12.6	6.6	5/8	4 1/2	4.55	18.2	21.0
1/4	2	0.82	3.4	4.00	3/8	5	3.10	13.6	16.2	5/8	5	5.10	20.4	23.8
1/4	2 1/2	1.06	4.4	5.30	3/8	5 1/2	3.50	15.4	18.4	5/8	5 1/2	5.65	22.8	26.4
1/4	3	1.23	5.2	6.20	3/8	6	3.73	16.2	19.4	5/8	6	6.15	25.0	29.0
5/16	1 1/2	0.79	3.6	4.4	1/2	2 1/2	2.20	9.0	10.8	5/8	7	7.30	29.6	34.2
5/16	2	1.10	4.6	5.6	1/2	3	2.50	10.4	12.6	5/8	8	8.40	34.0	39.4
5/16	2 1/2	1.35	6.0	7.0	1/2	3 1/2	2.80	12.0	14.4	3/4	5	6.85	27.0	31.4
5/16	3	1.60	7.2	8.6	1/2	4	3.15	13.8	16.4	3/4	6	7.50	30.2	35.0
5/16	3 1/2	1.88	8.2	10.0	1/2	4 1/2	3.85	16.6	19.8	3/4	7	8.25	33.6	38.8
5/16	4	2.15	9.6	11.4	1/2	5	4.20	18.0	21.6	3/4	8	9.75	40.4	46.8
3/8	2	1.30	5.4	6.6	1/2	5 1/2	4.55	19.6	23.6	.....	.....	.....	.....	.....
3/8	2 1/2	1.70	7.2	8.6	1/2	6	4.90	21.0	25.2	7/8	5	7.50	31.0	34.4
3/8	3	1.89	8.2	9.8	1/2	7	5.90	25.6	30.6	7/8	6	8.53	36.0	41.8
3/8	3	1.89	8.2	9.8	.....	.....	.....	.....	.....	7/8	7	9.56	40.6	46.6
3/8	3 1/2	2.30	10.0	12.0	5/8	3 1/2	3.50	13.6	15.8	7/8	8	10.60	45.0	51.6
3/8	4	2.43	10.8	13.0	5/8	4	4.00	15.8	18.4	.....	.....	.....	.....	.....

The allowable working load in the above table is 1/5 of the approximate breaking stress of the rope.

**Locked Wire Cable.**—Locked wire cable and locked coil-track cable, of the general form shown in Fig. 77, are used as track cables for aerial tramways. They differ only in the number and size of



Fig. 77.

wires used, and both are made of crucible cast steel. The locked wire cable is the more flexible of the two. These cables are smoother than the track cable described on page 260.

### Locked Coil and Locked Wire Cable.

Diam., In.	Wt. per Ft., Lb.		Breaking Stress, Tons (2000 Lbs.).		Diam., In.	Wt. per Ft., Lb.		Breaking Stress, Tons (2000 Lbs.).		Diam., In.	Wt. per Ft., Lbs.		Breaking Stress Tons (2000 Lbs.).	
	Locked Coil.	Locked Wire.	Locked Coil.	Locked Wire.		Locked Coil.	Locked Wire.	Locked Coil.	Locked Wire.		Locked Coil.	Locked Wire.	Locked Coil.	Locked Wire.
2 1/2	...	15.60	...	240	1 1/2	5.30	5.70	89	89	7/8	1.80	1.88	30	30
2 1/4	...	12.50	...	190	1 3/8	4.40	4.75	75	75	3/4	...	1.30	..	22
2	...	10.00	...	160	1 1/4	3.70	3.80	62	62	5/8	...	0.90	..	15.5
1 3/4	...	7.65	...	120	1 1/8	3.00	3.15	50	50	9/16	...	0.72	..	12.5
1 5/8	6.30	6.60	103	103	1	2.35	2.50	40	40	1/2	...	0.57	..	10

### Galvanized Steel Hawser.

For Lake and Deep Sea Towing and Mooring Lines.

Diam., In.	Circum., In.	Six 37-Wire Strands, 1 Hemp Core		Six 24-Wire Strands, 7 Hemp Cores.		Diam., In.	Circum., In.	Six 37-Wire Strands, 1 Hemp Core.		Six 24-Wire Strands, 7 Hemp Cores	
		Wt. per Ft., Lb.	Breaking Strength, Tons (2000 Lb.).	Wt. per Ft., Lb.	Breaking Strength, Tons (2000 Lb.).			Wt. per Ft., Lb.	Breaking Strength, Tons (2000 Lb.).	Wt. per Ft., Lb.	Breaking Strength, Tons (2000 Lb.).
2 3/8	7 1/2	8.82	188	...	...	1 1/2	4 3/4	3.55	76	3.10	63
2 5/16	7 1/4	8.36	182	...	...	1 7/16	4 1/2	3.24	72	2.92	55
2 1/4	7 1/8	8.00	171	...	...	1 3/8	4 1/4	3.00	66	2.62	50
2 1/8	6 3/4	7.06	155	...	...	1 1/4	4	2.45	54	2.15	42
2 1/16	6 1/2	6.65	140	5.81	113	1 3/16	3 3/4	2.21	47	1.93	38
2	6 1/4	6.30	132	5.51	106	1 1/8	3 1/2	2.00	42	1.75	34
1 15/16	6	5.84	125	5.09	98	1 1/16	3 1/4	1.77	38	1.54	27
1 13/16	5 3/4	5.13	112	4.48	88	1	3	1.58	31.5	1.38	25
1 3/4	5 1/2	4.85	104	4.24	82	7/8	2 3/4	1.20	26	1.05	20
1 11/16	5 1/4	4.42	97	3.86	76	13/16	2 1/2	1.03	22	0.90	17
1 5/8	5	4.15	87	3.63	74	3/4	2 1/4	0.89	20	0.78	14



**To Splice a Wire Rope.** — The tools required will be a small marline spike, nipping cutters, and either clamps or a small hemp-rope sling with which to wrap around and untwist the rope. If a bench-vise is accessible it will be found convenient.

In splicing rope, a certain length is used up in making the splice. An allowance of not less than 16 feet for 1/2-inch rope, and proportionately longer for larger sizes, must be added to the length of an endless rope in ordering.

Having measured, carefully, the length the rope should be after splicing, and marked the points *M* and *M'*, Fig. 78, unlay the strands from each end *E* and *E'* to *M* and *M'* and cut off the center at *M* and *M'*, and then:

(1). Interlock the six unlay strands of each end alternately and draw them together so that the points *M* and *M'* meet, as in Fig. 79.

(2). Unlay a strand from one end, and following the unlay closely, lay into the seam or groove it opens, the strand opposite it belonging to the other end of the rope, until within a length equal to three or four times the length of one lay of the rope, and cut the other strand to about the same length from the point of meeting as at *A*, Fig. 80.

(3). Unlay the adjacent strand in the opposite direction, and following the unlay closely, lay in its place the corresponding opposite strand, cutting the ends as described before at *B*, Fig. 80.

There are now four strands laid in place terminating at *A* and *B*, with the eight remaining at *MM'*, as in Fig. 80.

It will be well after laying each pair of strands to tie them temporarily at the points *A* and *B*.

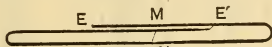

FIG. 78.

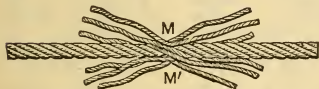

FIG. 79.

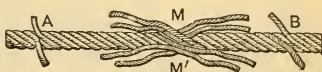

FIG. 80.

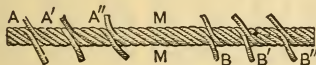
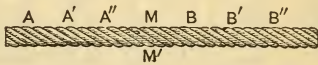

FIG. 81. SP LICING WIRE ROPE. FIG. 82.



Pursue the same course with the remaining four pairs of opposite strands, stopping each pair about eight or ten turns of the rope short of the preceding pair, and cutting the ends as before.

We now have all the strands laid in their proper places with their respective ends passing each other, as in Fig. 81.

All methods of rope-splicing are identical to this point: their variety consists in the method of tucking the ends. The one given below is the one most generally practiced.

Clamp the rope either in a vise at a point to the left of *A*, Fig. 81, and by a hand-clamp applied near *A*, open up the rope by untwisting sufficiently to cut the core at *A*, and seizing it with the nippers, let an assistant draw it out slowly, you following it closely, crowding the strand in its place until it is all laid in. Cut the core where the strand ends, and push the end back into its place. Remove the clamps and let the rope close together around it. Draw out the core in the opposite direction and lay the other strand in the center of the rope, in the same manner. Repeat the operation at the five remaining points, and hammer the rope lightly at the points where the ends pass each other at *A*, *A'*, *B*, *B'*, etc., with small wooden mallets, and the splice is complete, as shown in Fig. 82.

If a clamp and vise are not obtainable, two rope slings and short wooden levers may be used to untwist and open up the rope.

A rope spliced as above will be nearly as strong as the original rope and smooth everywhere. After running a few days, the splice, if well made, cannot be found except by close examination.

The above instructions have been adopted by the leading rope manufacturers of America.

CHAINS.

Weight per Foot, Proof Test and Breaking Weight.  
(Pennsylvania Railroad Specifications, 1903.)

Nominal Diameter of Wire. Inches.	Description.	Maximum Length of 100 Links. Inches.	Weight per Foot. Lbs.	Proof Test. Lbs.	Breaking Weight. Lbs.
5/32	Twisted chain . . . . .	103 1/8	0.20		
3/16	" " " " " " " " " " "	96 1/4	0.35		
3/16	Perfection twisted chain	151 1/4	0.27		
1/4	Straight-link chain . . . .	102	0.70	1,600	3,200
5/16	" " " " " " " " " " "	114 3/4	1.10	2,500	5,000
3/8	" " " " " " " " " " "	114 3/4	1.60	3,600	7,200
3/8	Crane chain . . . . .	113 5/8	1.60	4,140	8,280
7/16	Straight-link chain . . . . .	127 1/2	2.07	4,900	9,800
7/16	Crane chain . . . . .	126 1/4	2.07	5,635	11,270
1/2	Straight-link chain . . . . .	153	2.50	6,400	12,800
1/2	Crane chain . . . . .	151 1/2	2.60	7,360	14,720
5/8	Straight-link chain . . . . .	178 1/2	4.08	10,000	20,000
5/8	Crane chain . . . . .	176 3/4	4.18	11,500	23,000
3/4	Straight-link chain . . . . .	204	5.65	14,400	28,800
3/4	Crane chain . . . . .	202	5.75	16,560	33,120
7/8	" " " " " " " " " " "	252 1/2	7.70	22,540	45,080
1	" " " " " " " " " " "	277 3/4	9.80	29,440	58,880
1	Straight-link chain . . . . .	280 1/2	9.80	25,600	51,200
1 1/8	Crane chain . . . . .	303	12.65	38,260	76,520
1 1/4	" " " " " " " " " " "	353 1/2	15.50	46,000	92,000
1 1/2	" " " " " " " " " " "	416 5/8	22.50	66,240	132,480
1 3/4	" " " " " " " " " " "	479 3/4	30.00	90,160	180,320
2	" " " " " " " " " " "	555 1/2	39.00	117,760	235,520

Elongation of all sizes, 10 per cent. All chain must stand the proof test without deformation. A piece 2 ft. long out of each 200 ft. is tested to destruction.

**British Admiralty Proving Tests of Chain Cables.** — Stud-links. Minimum size in inches and 16ths. Proving test in tons of 2240 lbs.

Min. Size:	1 1/8	3/4	13/16	7/8	15/16	1	1 1/8	1 1/8	1 3/8	1 1/2	1 5/8	1 3/4
Test, tons:	8 1/2	10.1	11.9	13 3/4	15 1/4	18	20.3	22 1/4	25 3/8	28.1	31	34
Min. Size:	1 7/8	1 1/2	1 9/16	1 5/8	1 11/16	1 3/4	1 13/16	1 7/8	1 5/8	2	2 1/8	2 1/4
Test, tons:	37 3/8	40 1/2	43 9	47 1/8	51 1/4	55.1	59.1	63 1/4	67 3/8	72	81 1/4	

**Wrought-iron Chain Cables.** — The strength of a chain link is less than twice that of a straight bar of a sectional area equal to that of one side of the link. A weld exists at one end and a bend at the other, each requiring at least one heat, which produces a decrease in the strength. The report of the committee of the U. S. Testing Board (1879), on tests of wrought-iron and chain cables, contains the following conclusions. That beyond doubt, when made of American bar iron, with cast-iron studs, the studded link is inferior in strength to the unstudded one.

“That when proper care is exercised in the selection of material, a variation of 5 to 17 per cent of the strongest may be expected in the resistance of cables. Without this care, the variation may rise to 25 per cent.

“That with proper material and construction the ultimate resistance of the chain may be expected to vary from 155 to 170 per cent of that of the bar used in making the links, and show an average of about 163 per cent.

“That the proof test of a chain cable should be about 50 per cent of the ultimate resistance of the weakest link.”

The decrease of the resistance of the studded below the unstudded cable is probably due to the fact that in the former the sides of the link do not remain parallel to each other up to failure, as they do in the latter. The result is an increase of stress in the studded link over the unstudded in the proportion of unity, to the secant of half the inclination of the sides of the former to each other.

From a great number of tests of bars and unfinished cables, the committee considered that the average ultimate resistance, and proof tests of chain cables made of the bars, whose diameters are given, should be such as are shown in the accompanying table.

ULTIMATE RESISTANCE AND PROOF TESTS OF CHAIN CABLES.

Diam. of Bar.	Average resist. = 163% of Bar.	Proof Test.	Diam. of Bar.	Average resist. = 163% of Bar.	Proof Test.
Inches.	Pounds.	Pounds.	Inches.	Pounds.	Pounds.
1	71,172	33,840	19/16	162,283	77,159
1 1/16	79,544	37,820	15/8	174,475	82,956
1 1/8	88,445	42,053	1 11/16	187,075	88,947
1 3/16	97,731	45,468	1 3/4	200,074	95,128
1 1/4	107,440	51,084	1 13/16	213,475	101,499
1 5/16	117,577	55,903	1 7/8	227,271	108,058
1 3/8	128,129	60,920	1 15/16	241,463	114,806
1 7/16	139,103	66,138	2	256,040	121,737
1 1/2	150,485	71,550			

Pitch, Breaking, Proof and Working Strains of Chains.  
(Bradlee & Co., Philadelphia.)

Size of Chain, in.	Pitch, in.	Approx. Wt. per ft. lb.	Outside Width, in.	D. B. G. Special Crane.			Crane.		
				Proof Test, lb.	Average Breaking Strain, lb.	Ordinary Safe Load, General Use, lb.	Proof Test, lb.	Average Breaking Strain, lb.	Ordinary Safe Load, General Use, lb.
1/4	25/32	3/4	15/16	1,932	3,864	1,288	1,680	3,360	1,120
5/16	27/32	1	1 1/8	2,898	5,796	1,932	2,520	5,040	1,680
3/8	31/32	1 1/2	1 5/16	4,186	8,372	2,790	3,640	7,280	2,427
7/16	5/32	2	1 1/2	5,796	11,592	3,864	5,040	10,080	3,360
1/2	1 11/32	2 1/2	1 13/16	7,728	15,456	5,152	6,720	13,440	4,480
9/16	1 15/32	3 3/10	2	9,660	19,320	6,440	8,400	16,800	5,600
5/8	1 23/32	4 1/10	2 3/16	11,914	23,828	7,942	10,360	20,720	6,907
11/16	1 13/16	5	2 3/8	14,490	28,980	9,660	12,600	25,200	8,400
3/4	1 15/16	6 2/10	2 9/16	17,388	34,776	11,592	15,120	30,240	10,080
13/16	2 1/16	6 7/10	2 3/4	20,286	40,572	13,524	17,640	35,280	11,760
7/8	2 3/16	8 3/8	2 15/16	22,484	44,968	14,989	20,440	40,880	13,627
15/16	2 7/16	9	3 3/16	25,872	51,744	17,248	23,520	47,040	15,680
1	2 1/2	10 1/2	3 3/8	29,568	59,136	19,712	26,880	53,760	17,920
1 1/16	2 5/8	12	3 9/16	33,264	66,538	22,176	30,240	60,480	20,160
1 1/8	2 3/4	13 5/8	3 13/16	37,576	75,152	25,050	34,160	68,320	22,773
1 3/16	3 1/16	13 7/10	4	41,888	83,776	27,925	38,080	76,160	25,387
1 1/4	3 1/8	16	4 3/16	46,200	92,400	30,800	42,000	84,000	28,000
1 5/16	3 3/8	16 1/2	4 3/8	50,512	101,024	33,674	45,920	91,840	30,613
1 3/8	3 9/16	19 1/4	4 9/16	55,748	111,496	37,165	50,680	101,360	33,787
1 7/16	3 11/16	19 7/10	4 3/4	60,368	120,736	40,245	54,880	109,760	36,587
1 1/2	3 7/8	23	5 1/8	66,528	133,056	44,352	60,480	120,960	40,320
1 9/16	4	25	5 5/16	70,762	141,524	47,174	65,520	131,040	43,180
1 3/4	4 3/4	31	5 7/8	82,320	164,640	54,880			
2	5 3/4	40	6 3/4	107,520	215,040	71,680			
2 1/4	6 3/4	52 3/4	7 5/8	136,080	272,160	90,720			
2 1/2	7	64 1/2	8 3/8	168,000	336,000	112,000			
2 3/4	7 1/4	73	9 1/8	193,088	386,176	128,725			
3	7 3/4	86	9 7/8	217,728	435,456	145,152			

The distance from center of one link to center of next is equal to the inside length of link, but in practice 1/32 in. is allowed for weld. This is approximate, and where exactness is required, chain should be made so.

FOR CHAIN SHEAVES. — The diameter, if possible, should be not less than thirty times the diameter of chain used.

EXAMPLE. — For 1-inch chain use 30-inch sheaves.

SHAPES AND SIZES OF FIRE-BRICK.

(Stowe-Fuller Co., Cleveland, 1914.)

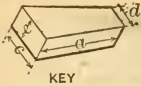

KEY



WEDGE AND BULLHEAD

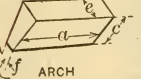

ARCH

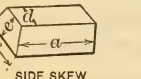

SIDE SKEW



END SKEW AND NECK

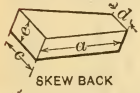

SKEW BACK

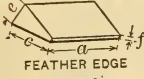

FEATHER EDGE

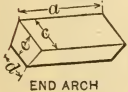

END ARCH

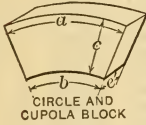

CIRCLE AND CUPOLA BLOCK

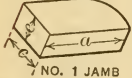

NO. 1 JAMB

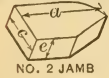

NO. 2 JAMB

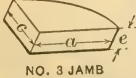

NO. 3 JAMB

Name of Brick or Tile.	Length, Inches.		Width, Inches.		Thick-ness, Inches.		No. of Brick to Circle.	Inside Diam. of Circle, In.
	Long Edge a	Short Edge b	Long Edge c	Short Edge d	Maxi- mum e	Mini- mum f		

STRAIGHT BRICK.

9-inch	9	.....	41/2	.....	21/2	.....	.....	.....
Large 9-inch	9	.....	63/4	.....	21/2	.....	.....	.....
Small 9- "	9	.....	31/2	.....	21/2	.....	.....	.....
Checker	9	.....	3	.....	3	.....	.....	.....
Soap	9	.....	21/2	.....	21/4	.....	.....	.....
No. 1 Split	9	.....	41/2	.....	11/4	.....	.....	.....
No. 2 "	9	.....	41/2	.....	2	.....	.....	.....
Checker Tile	18,20, 24	.....	6	.....	3	.....	.....	.....
Mill "	18,20, 24	.....	9	.....	3	.....	.....	.....
Mill Block	18	.....	9	.....	6	.....	.....	.....
No. 1 Bridgwall	13	.....	61/2	.....	6	.....	.....	.....
No. 2 "	13	.....	61/2	.....	3	.....	.....	.....

WEDGE SHAPE AND TAPER BRICKS.

Large 9-in. No. 1 Wedge	9	.....	63/4	.....	21/2	17/8	102	60
Large 9-in. No. 2 Wedge	9	.....	63/4	.....	21/2	11/2	63	30
No. 1 Wedge	9	.....	41/2	.....	21/2	2	102	60
No. 2 "	9	.....	41/2	.....	21/2	11/2	63	30
No. 1 Key*	9	.....	41/2	4	21/2	.....	112	144
No. 2 " *	9	.....	41/2	31/2	21/2	.....	65	72
No. 3 " *	9	.....	41/2	3	21/2	.....	41	36
No. 4 " *	9	.....	41/2	21/4	21/2	.....	26	18
No. 1 Arch†	9	.....	41/2	.....	21/2	2	72	48
No. 2 " †	9	.....	41/2	.....	21/2	11/2	42	24
Side Skew	9	.....	41/2	13/4	21/2	0	.....	.....
End Skew	9	7	41/2	.....	21/2	0	.....	.....
Skew Back	9	.....	41/2	11/2	21/2	.....	.....	.....
No. 1 Neck	9	41/2	41/2	.....	21/2	.....	.....	.....
No. 2 "	9	2	41/2	.....	21/2	.....	.....	.....
No. 3 "	9	0	41/2	.....	21/2	5/8	.....	.....
Feather Edge	9	.....	41/2	.....	21/2	1/8	.....	.....
Jamb	9	.....	41/2	.....	21/2	.....	.....	.....
Bullhead	9	.....	41/2	.....	3	2	.....	36
Edge Arch	9	.....	41/2	3	21/2	.....	.....	.....

CIRCLE BRICK, Curved Edges.

No. 1	81/2	51/4	41/2	.....	21/2	.....	9	15
No. 2	9	69/10	41/2	.....	21/2	.....	11	24
No. 3	9	73/16	41/2	.....	21/2	.....	14	36
No. 4	9	79/16	41/2	.....	21/2	.....	20	48
No. 5	9	75/8	41/2	.....	21/2	.....	24	60

CUPOLA BLOCKS.

No. 1	9	63/8	6	.....	4	.....	15	30
No. 2	9	63/4	6	.....	4	.....	17	36
No. 3	9	71/8	6	.....	4	.....	21	48
No. 4	9	71/2	6	.....	4	.....	52	60

\*Tapers lengthwise. †Tapers breadthwise.

Other special shapes of brick and tile manufactured are: Locomotive tile, 32, 34, and 40 in. X 10 in. X 3 in.; 34 and 36 in. X 8 in. X 3 in. Blast Furnace Shapes, 13 1/2 X 6 X 2 1/2 in. straight; No. 1, 12 ft. Key



13 1/2 x 6 x 5 x 2 1/2 in. thick, 91 brick to circle; No. 2, 6 ft. Key 13 1/2 x 6 x 43/8 x 2 1/2 in. thick, 53 brick to circle; bottom blocks, 18 x 9 x 4 1/2 in. straight. Standard Block Linings, 9 x 9, 12 x 9, 15 x 9, 18 x 9, all 4 1/2 in. thick, made straight, and as key-brick for use with straight brick to line any diameter of furnace; the key-bricks are made for radii of 5, 7 1/2, and 10 ft. Pottery Kiln Brick, flat back, 9 x 6 x 2 1/2 in.; flat back arch, 9 x 6 x 3 1/4 x 2 1/2 in.; 56 brick to a 32-inch inside diam. circle, No. 2 flat back arch, 9 x 6 x 3 1/4 x 2 in., 31 brick to a 22-inch inside diam. circle.

A straight 9-inch fire-brick weighs 7 lbs., a silica brick, 6.2 lbs.; a magnesia brick, 9 lbs.; a chrome brick, 10 lbs. A silica brick expands about 1/8 inch per foot when heated to 2,500° F.

Clay brick expand or shrink, dependent upon the proportion of silica to alumina contained in the brick; but most fire clay brick contain alumina sufficient to show some shrinkage.

One cubic foot of wall requires 17, 9-inch bricks; one cubic yard, requires 460. Where keys, wedges, and other "shapes" are used, add 10 per cent, in estimating the number required.

To secure the best results, fire-brick should be laid in the same clay from which they are manufactured. One ton of ground clay should be sufficient to lay 3,000 ordinary bricks. It should be used as a thin paste and not as mortar. The thinner the joint the better the furnace wall. In ordering bricks, the service for which they are to be used should be stated.

Silica brick should be laid in silica cement and with the smallest joint possible.

Ground fire-brick or old cupola blocks mixed with fire-clay make the best cupola daub known.

**NUMBER OF FIRE-BRICK REQUIRED FOR VARIOUS CIRCLES.**

Diam. of Circle.	Key Bricks.					Arch Bricks.				Wedge Bricks.			
	No. 4.	No. 3.	No. 2.	No. 1.	Total.	No. 2.	No. 1.	9-in.	Total.	No. 2.	No. 1.	9-in.	Total.
1 6	25	...	...	...	25	...	...	...	...	...	...	...	...
2 0	17	13	...	...	30	42	...	...	42	...	...	...	...
2 6	9	25	...	...	34	31	18	...	49	60	...	...	60
3 0	...	38	...	...	38	21	36	...	57	48	20	...	68
3 6	...	32	10	...	42	10	54	...	64	36	40	...	76
4 0	...	25	21	...	46	...	72	...	72	24	59	...	83
4 6	...	19	32	...	51	...	72	8	80	12	79	...	91
5 0	...	13	42	...	55	...	72	15	87	...	98	...	98
5 6	...	6	53	...	59	...	72	23	95	...	98	8	106
6 0	...	...	63	...	63	...	72	30	102	...	98	15	113
6 6	...	...	58	9	67	...	72	38	110	...	98	23	121
7 0	...	...	52	19	71	...	72	45	117	...	98	30	128
7 6	...	...	47	29	76	...	72	53	125	...	98	38	136
8 0	...	...	42	38	80	...	72	60	132	...	98	46	144
8 6	...	...	37	47	84	...	72	68	140	...	98	53	151
9 0	...	...	31	57	88	...	72	75	147	...	98	61	159
9 6	...	...	26	66	92	...	72	83	155	...	98	68	166
10 0	...	...	21	76	97	...	72	90	162	...	98	76	174
10 6	...	...	16	85	101	...	72	98	170	...	98	83	181
11 0	...	...	11	94	105	...	72	105	177	...	98	91	189
11 6	...	...	5	104	109	...	72	113	185	...	98	98	196
12 0	...	...	...	113	113	...	72	121	193	...	98	106	204
12 6	...	...	...	113	117	...	...	...	...	...	...	...	...

For larger circles than 12 feet use 113 No. 1 Key, and as many 9-inch brick as may be needed in addition.

**Refractoriness of Some American Fire-Brick.**—(R. F. Weber, A. I. M. E., 1904.) Prof. Heinrich Ries notes that the fusibility of New Jersey brick is influenced largely by its percentage of silica, but also in part by the texture of the clay. It was found that the fusion-point of almost any of the New Jersey fire-bricks could be reduced four or five Seger cones by grinding the brick sufficiently fine to pass through a 700-mesh sieve.

Mr. Weber draws the conclusion from his tests of 44 bricks that it is evident that the refractoriness of a fire-brick depends on the total quantity of fluxes present, the silica percentage and the coarseness of grain; moreover, chemical analysis alone cannot be used as an index of the refractoriness except within rather wide limits. The following table shows the composition, fusion-point, and physical properties of six most refractory and of five least refractory of the 44 bricks.

Number of Sample.	Locality.	SiO <sub>2</sub> .	Al <sub>2</sub> O <sub>3</sub> .	Fe <sub>2</sub> O <sub>3</sub> .	TiO <sub>2</sub> .	Alkaline Earths and Alkalies.	Sum of Fluxes.	Cone of Fusion.
		Per cent.	Per cent.	Per cent.	Per cent.	Per cent.	Per cent.	No.
1....	Missouri.....	51.59	38.26	1.84	1.97	6.34	10.25	32 to 33
2....	Kentucky.....	54.90	38.19	2.18	1.55	3.18	6.91	32 to 33
3....	Pennsylvania....	53.05	41.16	2.65	1.80	1.34	5.79	32 to 33
4....	Colorado.....	93.57	2.53	0.62	0.27	3.01	3.90	32 to 33
5....	Kentucky.....	44.77	43.08	2.78	2.54	6.83	12.15	31 to 32
6....	New York.....	68.70	20.75	1.20	5.54	3.81	10.55	31 to 32
40....	Pennsylvania....	61.28	27.13	2.90	1.37	7.31	11.58	26
41....	Pennsylvania....	74.83	16.40	3.26	0.77	4.74	8.77	26
42....	Alabama.....	67.19	25.05	2.83	0.71	4.22	7.76	26
43....	Indiana.....	60.76	31.66	5.67	1.58	0.33	7.58	26
44....	Kentucky.....	60.58	32.49	2.25	1.69	2.99	6.93	26

<sup>1</sup> Fairly uniform, angular flint-clay particles, constituting body of brick. Largest pieces 5 to 6 mm. in diameter. White.

<sup>2</sup> Coarse-grained; angular pieces of flint-clay as large as 9 mm. Average 4 to 5 mm. Light buff.

<sup>3</sup> Coarse, angular flint-clay particles, varying from 1 to 5 mm. in diameter. Average 4 to 5 mm. Buff.

<sup>4</sup> Fine-grained quartz particles. Largest 2 to 3 mm. in diameter. White.

<sup>5</sup> Medium grain; flint-clay particles, fairly uniform in size, 3 to 4 mm. Light buff.

<sup>6</sup> Coarse grain; quartz particles, 4 to 5 mm. in diameter, forming about 50 per cent of brick. White.

<sup>40</sup> Fine grain; small, white flint-clay particles, not over 2 mm. in diameter and not abundant. Buff.

<sup>41</sup> Medium grain; pieces of quartz with pinkish color and angular flint-clay particles. About 3 mm. in diameter. Buff.

<sup>42</sup> Fine grain; even texture. Few coarse particles. Brown.

<sup>43</sup> Fine grain; some particles as large as 1 to 2 mm. in diameter. Buff.

<sup>44</sup> Angular, dark-colored, flinty-clay particles. Maximum size 5 mm. Throughout a reddish-brown matrix.

### SLAG BRICKS AND SLAG BLOCKS.

Slag bricks are made by mixing granulated basic slag and slaked lime, molding the mixture in a brick press or by hand, and drying. The silica in the slag ranges from 22.5% to 35%; the alumina and iron oxide together, from 16.1% to 21%; the lime, from 40% to 51.5%. The granulated slag is dried and pulverized. Powdered slaked lime is added in sufficient quan-

tity to bring the total calcium oxide in the mixture up to about 55%. Usually a small amount of water is added. The mixture is then molded into shape, and the bricks are then dried for six to ten days in the open air. Slag bricks weigh less than clay bricks of equal size, require less mortar in laying up, and are at least equal to them in crushing strength.

Slag blocks are made by running molten slag direct from the furnaces into molds. If properly made, they are stronger than slag bricks. They are, however, impervious to air and moisture; and on that account dwellings constructed of them are apt to be damp. Their chief uses are for foundations or for paving blocks. The properties required in a slag paving block, viz: density, resistance to abrasion, toughness, and roughness of surface, vary with the chemical composition of the slag, the rapidity of cooling, and the character of the molds used. Blocks cast in sand molds, and heavily covered with loose sand, cool slowly, and give much better results than those cast in iron molds. — E. C. Eckel, *Eng. News*, April 30, 1903.

## ANALYSES OF FIRE CLAYS.

Brand.	Titanic Acid, TiO <sub>2</sub>	Silica, SiO <sub>2</sub>	Alumina, Al <sub>2</sub> O <sub>3</sub>	Moisture, H <sub>2</sub> O	Iron, Fe <sub>2</sub> O <sub>3</sub>	Lime, CaO	Magnesia, MgO	Potash, K <sub>2</sub> O	Soda, Na <sub>2</sub> O	Total Im- purities.	Loss.
Mt. Savage <sup>1</sup> . . . . .	50.46	35.90	12.744	1.50	0.13	0.02	Trace	1.65	.....	.....	.....
Mt. Savage <sup>2</sup> . . . . .	1.15	56.80	30.08	10.50	1.12	.....	0.80	1.92	.....	.....	.....
Mt. Savage <sup>3</sup> . . . . .	1.53	44.40	33.56	14.575	1.08	Tr.	0.11	0.247	1.47	.....	.....
Mt. Savage <sup>4</sup> . . . . .	.....	56.15	33.30	9.68	0.59	0.17	0.12	.....	.....	0.88	.....
Strasburg, O. . . . .	0.45	55.87	41.39	.....	1.60	0.40	0.30	0.29	0.20	2.79	.....
Cumberland, Md. . . . .	1.15	56.80	30.08	7.69	1.67	.....	.....	2.30	.....	3.97	.....
Woodbridge, N.J. . . . .	.....	67.84	21.83	5.98	1.57	0.28	0.24	2.24	.....	4.33	.....
Carter Co., Ky. . . . .	.....	68.01	24.09	3.03	1.01	3.01	.....	.....	.....	4.02	.....
Clearfield Co., Pa. . . . .	.....	48.35	36.37	10.56	2.00	0.07	0.12	2.54	.....	4.73	.....
Clearfield <sup>5</sup> and Cambria Cos., Pa. <sup>6</sup> . . . . .	.....	44.80	39.00	14.70	0.30	0.20	1.00	.....	.....	.....	.....
Clinton Co., Pa. . . . .	1.46	51.50	44.85	1.94	0.33	0.23	1.15	.....	.....	.....	.....
Clarion Co., Pa. . . . .	1.02	63.18	23.70	6.87	1.20	0.17	0.47	2.52	4.55	SO <sub>2</sub> 0.19	.....
Farrandville Pa. . . . .	.....	44.61	38.01	13.63	1.25	0.08	0.41	1.74	3.47	.....	.....
St. Louis Co., Mo. . . . .	.....	45.26	37.85	13.30	2.03	0.08	0.02	1.26	3.59	0.20	.....
Göttwerth, Aus. . . . .	.....	67.47	19.33	10.45	2.56	0.41	0.07	1.07	5.14	.....	.....
Stourbridge, En. . . . .	.....	65.60	20.75	11.00	2.00	1.65	Tr.	Tr.	.....	3.65	.....
Glenboig, Scot. . . . .	1.33	73.82	15.88	6.45	2.95	Tr.	Tr.	0.90	3.85	.....	.....
La Bouchade, Fr. . . . .	.....	65.41	30.55	.....	1.70	.....	.....	.....	3.58	.....	.....
Coblentz, Ger. . . . .	.....	53.40	26.40	12.00	4.20	0.69	0.64	0.55	4.20	.....	.....
Diesdorf, Rhine- land . . . . .	.....	55.46	31.74	9.37	0.59	0.19	0.14	2.49	0.68	4.09	.....
Dowlair, Wales. . . . .	.....	73.71	18.33	5.17	0.89	Tr.	0.10	2.12	0.24	3.85	.....
.....	.....	67.12	21.18	6.21	1.85	0.32	0.84	2.02	.....	5.93	0.90

<sup>1</sup> Mass. Inst. of Technology, 1871. <sup>2</sup> Report on Clays of New Jersey. Prof. G. H. Cook, 1877. <sup>3</sup> Second Geological Survey of Penna., 1878. <sup>4</sup> Dr. Otto Wuth (2 samples), 1885. <sup>5</sup> Flint clay from Clearfield and Cambria counties, Pa., average of hundreds of analyses by Harbison-Walker Refractories Co., Pittsburg, Pa. <sup>6</sup> Same material calcined. All other analyses from catalogue of Stowe-Fuller Co., 1914.

## MAGNESIA BRICKS.

"Foreign Abstracts" of the Institution of Civil Engineers, 1893, gives a paper by C. Bischof on the production of magnesia bricks. The material most in favor at present is the magnesite of Styria, which, although less pure considered as a source of magnesia than the Greek, has the property of fritting at a high temperature without melting.

At a red heat magnesium carbonate is decomposed into carbonic acid and caustic magnesia, which resembles lime in becoming hydrated and



recarbonated when exposed to the air, and possesses a certain plasticity, so that it can be moulded when subjected to a heavy pressure. By long-continued or stronger heating the material becomes dead-burnt, giving a form of magnesia of high density, sp. gr. 3.8, as compared with 3.0 in the plastic form, which is unalterable in the air but devoid of plasticity. A mixture of two volumes of dead-burnt with one of plastic magnesia can be moulded into bricks which contract but little in firing. Other binding materials that have been used are: clay up to 10 or 15 per cent; gas-tar, perfectly freed from water, soda, silica, vinegar as a solution of magnesium acetate which is readily decomposed by heat, and carbolates of alkalis or lime. Among magnesium compounds a weak solution of magnesium chloride may also be used. For setting the bricks lightly burnt, caustic magnesia, with a small proportion of silica to render it less refractory, is recommended. The strength of the bricks may be increased by adding iron, either as oxide or silicate. If a porous product is required, sawdust or starch may be added to the mixture. When dead-burnt magnesia is used alone, soda is said to be the best binding material. See also papers by A. E. Hunt, *Trans. A. I. M. E.*, xvi, 720, and by T. Egleston, *Trans. A. I. M. E.*, xiv, 458.

The average composition of magnesite, crude and calcined, is given as follows by the Harbison-Walker Refractories Co., Pittsburg (1907).

	Grecian.		Styrian.	
	Crude.	Calcined.	Crude.	Calcined.
Carbonate of magnesia	97.00%	.....	92.50%	.....
Magnesia.....	.....	94.00%	.....	85.50%
Silica.....	1.25	2.75	1.50	3.00
Alumina.....	0.40	0.70	0.50	1.00
Iron Oxide.....	0.40	0.80	3.90	8.00
Lime.....	0.75	1.50	1.25	2.50
Loss.....	.....	0.40	.....	0.50
	<u>100.05</u>	<u>100.15</u>	<u>99.65</u>	<u>100.50</u>

With the calcined Styrian magnesite of the above analysis it is not necessary to use a binder either for making brick or for forming the bottom of an open-hearth furnace.

### ZIRCONIA.

Zirconia ore (84.1 ZrO<sub>2</sub>; 7.74 SiO<sub>2</sub>; 3.10 Fe<sub>2</sub>O<sub>3</sub>; 1.21 TiO<sub>2</sub>; 0.66 Al<sub>2</sub>O<sub>3</sub>; loss on ignition 2.72) vitrifies slightly at 1830° C. (3326° F.). Mixed with different percentages of clay and molded into cones it vitrifies at somewhat lower temperatures. A zirconia brick containing 5% clay became plastic on its face at 1800° C. (3272° F.). (H. Conrad Meyer, *Met. & Chem. Eng.*, Vol. xii, No. 12, 1914, Vol. xiii, No. 4, 1915; Circular of Foote Mineral Co., Philadelphia.)

### ASBESTOS.

The following analyses of asbestos are given by J. T. Donald, *Eng. and M. Jour.*, June 27, 1891.

	Italian.	Canadian.	
		Broughton.	Templeton.
Silica.....	40.30%	40.57%	40.52%
Magnesia.....	43.37	41.50	42.05
Ferrous oxide.....	.87	2.81	1.97
Alumina.....	2.27	.90	2.10
Water.....	<u>13.72</u>	<u>13.55</u>	<u>13.46</u>
	<u>100.53</u>	<u>99.33</u>	<u>100.10</u>

Chemical analysis throws light upon an important point in connection with asbestos, i.e., the cause of the harshness of the fibre of some varieties. Asbestos is principally a hydrous silicate of magnesia, i.e., silicate of magnesia combined with water. When harsh fibre is analyzed it is found to contain less water than the soft fibre. In fibre of very fine quality from Black Lake analysis showed 14.38% of water, while a harsh-fibred sample gave only 11.70%. If soft fibre be heated to a temperature that will drive off a portion of the combined water, there results a substance so brittle that it may be crumbled between thumb and finger. There is evidently some connection between the consistency of the fibre and the amount of water in its composition.



**STANDARD CROSS SECTIONS.**

Recommended by a Committee of the Am. Soc. M. E., 1912.

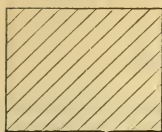

Cast Iron

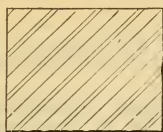

Wrought Iron

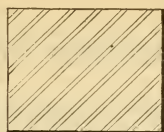

Cast Steel

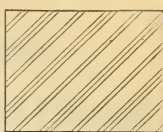

Wrought Steel

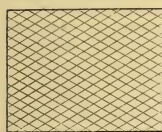

Babbitt or White Metal

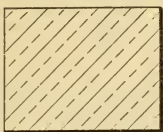

Copper, Brass or Composition

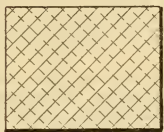

Aluminum



Rubber, Vulcanite or Insulation

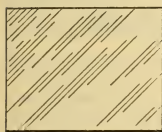

Glass



Wood

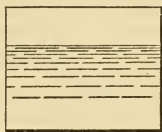

Water

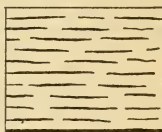

Puddle

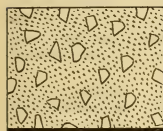

Concrete

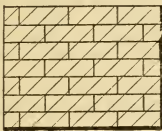

Brick

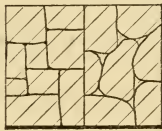

Coursed Uncoursed Rubble



Ashlar



Rock

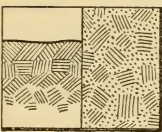

Original Filling Earth

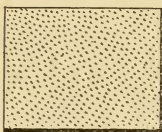

Sand



Other Materials

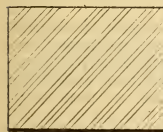

Wrought Steel



Nickel Steel

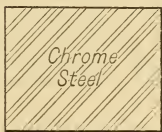

Chrome Steel



Vanadium Steel

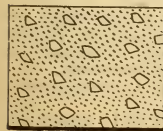

Concrete

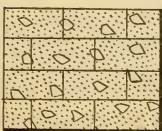

Concrete Blocks

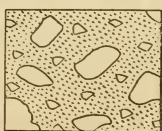

Cyclopean Concrete

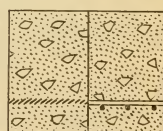

Expanded Metal Wire or Rods Reinforced Concrete

## STRENGTH OF MATERIALS.

**Stress and Strain.** — There is much confusion among writers on strength of materials as to the definition of these terms. An external force applied to a body, so as to pull it apart, is resisted by an internal force, or resistance, and the action of these forces causes a displacement of the molecules, or deformation. By some writers the external force is called a stress, and the internal force a strain; others call the external force a strain, and the internal force a stress; this confusion of terms is not of importance, as the words stress and strain are quite commonly used synonymously, but the use of the word strain to mean molecular displacement, deformation, or distortion, as is the custom of some, is a corruption of the language. See *Engineering News*, June 23, 1892. Some authors in order to avoid confusion never use the word strain in their writings. Definitions by leading authorities are given below.

**Stress.** — A stress is a force which acts in the interior of a body, and resists the external forces which tend to change its shape. A deformation is the amount of change of shape of a body caused by the stress. The word strain is often used as synonymous with stress, and sometimes it is also used to designate the deformation. (Merriman.)

The force by which the molecules of a body resist a strain at any point is called the stress at that point.

The summation of the displacements of the molecules of a body for a given point is called the distortion or strain at the point considered. (Burr.)

Stresses are the forces which are applied to bodies to bring into action their elastic and cohesive properties. These forces cause alterations of the forms of the bodies upon which they act. *Strain* is a name given to the kind of alteration produced by the stresses. The distinction between stress and strain is not always observed, one being used for the other. (Wood.)

The use of the word stress as synonymous with "stress per square inch," or with "strength per square inch," should be condemned as lacking in precision.

Stresses are of different kinds, viz.: *tensile, compressive, transverse, torsional, and shearing stresses.*

A *tensile stress*, or pull, is a force tending to elongate a piece. A *compressive stress*, or push, is a force tending to shorten it. A *transverse stress* tends to bend it. A *torsional stress* tends to twist it. A *shearing stress* tends to force one part of it to slide over the adjacent part.

Tensile, compressive, and shearing stresses are called simple stresses. Transverse stress is compounded of tensile and compressive stresses, and torsional of tensile and shearing stresses.

To these five varieties of stresses might be added *tearing stress*, which is either tensile or shearing, but in which the resistance of different portions of the material are brought into play in detail, or one after the other, instead of simultaneously, as in the simple stresses.

**Effects of Stresses.** — The following general laws for cases of simple tension or compression have been established by experiment (Merriman):

1. When a small stress is applied to a body, a small deformation is produced, and on the removal of the stress the body springs back to its original form. For small stresses, then, materials may be regarded as perfectly elastic.

2. Under small stresses the deformations are approximately proportional to the forces or stresses which produce them, and also approximately proportional to the length of the bar or body.

3. When the stress is great enough a deformation is produced which is partly permanent, that is, the body does not spring back entirely to its original form on removal of the stress. This permanent part is termed a set. In such cases the deformations are not proportional to the stress.

4. When the stress is greater still the deformation rapidly increases and the body finally ruptures.

5. A sudden stress, or shock, is more injurious than a steady stress or than a stress gradually applied.

**Elastic Limit.** — The elastic limit is defined as that load at which the deformations cease to be proportional to the stresses, or at which the rate of stretch (or other deformation) begins to increase. It is also defined as the load at which a permanent set first becomes visible. The last definition is not considered as good as the first, as it is found that with some materials a set occurs with any load, no matter how small, and that with others a set which might be called permanent vanishes with lapse of time, and as it is impossible to get the point of first set without removing the whole load after each increase of load, which is frequently inconvenient. The elastic limit, defined, however, as that stress at which the extensions begin to increase at a higher rate than the applied stresses, usually corresponds very nearly with the point of first measurable permanent set.

**Apparent Elastic Limit.** — Prof. J. B. Johnson (*Materials of Construction*, p. 19) defines the "apparent elastic limit" as "the point on the stress diagram [a plotted diagram in which the ordinates represent loads and the abscissas the corresponding elongations] at which the rate of deformation is 50% greater than it is at the origin," [the minimum rate]. An equivalent definition, proposed by the author, is that point at which the modulus of extension ( $\text{length} \times \text{increment of load per unit of section} \div \text{increment of elongation}$ ) is two thirds of the maximum. For steel, with a modulus of elasticity of 30,000,000, this is equivalent to that point at which the increase of elongation in an 8-inch specimen for 1000 lbs. per sq. in. increase of load is 0.0004 in.

**Yield-point.** — The term yield-point has recently been introduced into the literature of the strength of materials. It is defined as that point at which the rate of stretch suddenly increases rapidly with no increase of the load. The difference between the elastic limit, strictly defined as the point at which the rate of stretch begins to increase, and the yield-point, may in some cases be considerable. This difference, however, will not be discovered in short test-pieces unless the readings of elongations are made by an exceedingly fine instrument, as a micrometer reading to 0.0001 inch. In using a coarser instrument, such as calipers reading to 1/100 of an inch, the elastic limit and the yield-point will appear to be simultaneous. Unfortunately for precision of language, the term yield-point was not introduced until long after the term elastic limit had been almost universally adopted to signify the same physical fact which is now defined by the term yield-point, that is, not the point at which the first change in rate, observable only by a microscope, occurs, but that later point (more or less indefinite as to its precise position) at which the increase is great enough to be seen by the naked eye. A most convenient method of determining the point at which a sudden increase of rate of stretch occurs in short specimens, when a testing-machine in which the pulling is done by screws is used, is to note the weight on the beam at the instant that the beam "drops." During the earlier portion of the test, as the extension is steadily increased by the uniform but slow rotation of the screws, the poise is moved steadily along the beam to keep it in equipoise; suddenly a point is reached at which the beam drops, and will not rise until the elongation has been considerably increased by the further rotation of the screws, the advancing of the poise meanwhile being suspended. This point corresponds practically to the point at which the rate of elongation suddenly increases, and to the point at which an appreciable permanent set is first found. It is also the point which has hitherto been called in practice and in text-books the elastic limit, and it will probably continue to be so called, although the use of the newer term "yield-point" for it, and the restriction of the term elastic limit to mean the earlier point at which the rate of stretch begins to increase, as determinable only by micrometric measurements, is more precise and scientific. In order to obtain the yield-point by the drop of the beam with approximate accuracy, the screws of the testing machine must be run very slowly as the yield-point is approached, so as to cause an elongation of not more than, say, 0.005 in. per minute.

In tables of strength of materials hereafter given, the term elastic limit is used in its customary meaning, the point at which the rate of stress has begun to increase as observable by ordinary instruments or by the drop of the beam. With this definition it is practically synonymous with yield-point.



**Coefficient (or Modulus) of Elasticity.** — This is a term expressing the relation between the amount of extension or compression of a material and the load producing that extension or compression.

It is defined as the load per unit of section divided by the extension per unit of length.

Let  $P$  be the applied load,  $k$  the sectional area of the piece,  $l$  the length of the part extended,  $\lambda$  the amount of the extension, and  $E$  the coefficient of elasticity. Then  $P \div k =$  the load on a unit of section;  $\lambda \div l =$  the elongation of a unit of length.

$$E = \frac{P}{k} \div \frac{\lambda}{l} = \frac{Pl}{k\lambda}.$$

The coefficient of elasticity is sometimes defined as the figure expressing the load which would be necessary to elongate a piece of one square inch section to double its original length, provided the piece would not break, and the ratio of extension to the force producing it remained constant. This definition follows from the formula above given, thus: If  $k =$  one square inch,  $l$  and  $\lambda$  each = one inch, then  $E = P$ .

Within the elastic limit, when the deformations are proportional to the stresses, the coefficient of elasticity is constant, but beyond the elastic limit it decreases rapidly.

In cast iron there is generally no apparent limit of elasticity, the deformations increasing at a faster rate than the stresses, and a permanent set being produced by small loads. The coefficient of elasticity therefore is not constant during any portion of a test, but grows smaller as the load increases. The same is true in the case of timber. In wrought iron and steel, however, there is a well-defined elastic limit, and the coefficient of elasticity within that limit is nearly constant.

**Resilience, or Work of Resistance of a Material.** — Within the elastic limit, the resistance increasing uniformly from zero stress to the stress at the elastic limit, the work done by a load applied gradually is equal to one half the product of the final stress by the extension or other deformation. Beyond the elastic limit, the extensions increasing more rapidly than the loads, and the strain diagram (a plotted diagram showing the relation of extensions to stresses) approximating a parabolic form, the work is approximately equal to two thirds the product of the maximum stress by the extension.

The amount of work required to break a bar, measured usually in inch-pounds, is called its resilience; the work required to strain it to the elastic limit is called its elastic resilience. (See below.)

Under a load applied suddenly the momentary elastic distortion is equal to twice that caused by the same load applied gradually.

When a solid material is exposed to percussive stress, as when a weight falls upon a beam transversely, the work of resistance is measured by the product of the weight into the total fall.

**Elastic Resilience.** — In a rectangular beam tested by transverse stress, supported at the ends and loaded in the middle,

$$P = \frac{2}{3} \frac{Rbd^2}{l}; \quad (1) \qquad \Delta = \frac{1}{4} \frac{Pl^3}{Ebd^3}; \quad (2)$$

in which, if  $P$  is the load in pounds at the elastic limit,  $R =$  the modulus of transverse strength, or the stress on the extreme fibre, at the elastic limit,  $E =$  modulus of elasticity,  $\Delta =$  deflection,  $l$ ,  $b$ , and  $d =$  length, breadth, and depth in inches. Substituting for  $P$  in (2) its value in (1),  $\Delta = 1/6 Rl^2 \div Ed$ .

The elastic resilience = half the product of the load and deflection =  $1/2 P \Delta$ , and the elastic resilience per cubic inch =  $1/2 P \Delta \div lbd$ .

Substituting the values of  $P$  and  $\Delta$ , this reduces to elastic resilience per cubic inch =  $\frac{1}{18} \frac{R^2}{E}$ , which is independent of the dimensions; and therefore the elastic resilience per cubic inch for transverse strain may be used as a modulus expressing one valuable quality of a material.



Similarly for tension: Let  $P$  = tensile stress in pounds per square inch at the elastic limit;  $e$  = elongation per unit of length at the elastic limit.  $E$  = modulus of elasticity =  $P \div e$ ; whence  $e = P \div E$ .

Then elastic resilience per cubic inch =  $\frac{1}{2} Pe = \frac{1}{2} \frac{P^2}{E}$

**Elevation of Ultimate Resistance and Elastic Limit.** — It was first observed by Prof. R. H. Thurston, and Commander L. A. Beardslee, U. S. N., independently, in 1873, that if wrought iron be subjected to a stress beyond its elastic limit, but not beyond its ultimate resistance, and then allowed to "rest" for a definite interval of time a considerable increase of elastic limit and ultimate resistance may be experienced. In other words, the application of stress and subsequent "rest" increases the resistance of wrought iron. This "rest" may be an entire release from stress or a simple holding the test-piece at a given intensity of stress.

Commander Beardslee prepared twelve specimens and subjected them to a stress equal to the ultimate resistance of the material, without breaking the specimens. These were then allowed to rest, entirely free from stress, from 24 to 30 hours, after which they were again stressed until broken. The gain in ultimate resistance by the rest was found to vary from 4.4 to 17 per cent.

This elevation of elastic and ultimate resistance appears to be peculiar to iron and steel; it has not been found in other metals.

**Relation of the Elastic Limit to Endurance under Repeated Stresses** (condensed from *Engineering*, August 7, 1891). — When engineers first began to test materials, it was soon recognized that if a specimen was loaded beyond a certain point it did not recover its original dimensions on removing the load, but took a permanent set; this point was called the elastic limit. Since below this point a bar appeared to recover completely its original form and dimensions on removing the load, it appeared obvious that it had not been injured by the load, and hence the working load might be deduced from the elastic limit by using a small factor of safety.

Experience showed, however, that in many cases a bar would not carry safely a stress anywhere near the elastic limit of the material as determined by these experiments, and the whole theory of any connection between the elastic limit of a bar and its working load became almost discredited, and engineers employed the ultimate strength only in deducing the safe working load to which their structures might be subjected. Still, as experience accumulated it was observed that a higher factor of safety was required for a live load than for a dead one.

In 1871 Wöhler published the results of a number of experiments on bars of iron and steel subjected to live loads. In these experiments the stresses were put on and removed from the specimens without impact, but it was, nevertheless, found that the breaking stress of the materials was in every case much below the statical breaking load. Thus, a bar of Krupp's axle steel having a tenacity of 49 tons per square inch broke with a stress of 28.6 tons per square inch, when the load was completely removed and replaced without impact 170,000 times. These experiments were made on a large number of different brands of iron and steel, and the results were concordant in showing that a bar would break with an alternating stress of only, say, one third the statical breaking strength of the material, if the repetitions of stress were sufficiently numerous. At the same time, however, it appeared from the general trend of the experiments that a bar would stand an indefinite number of alternations of stress, provided the stress was kept below the limit.

Prof. Bauschinger defines the elastic limit as the point at which stress ceases to be sensibly proportional to extension, the latter being measured with a mirror apparatus reading to  $1/5000$  of a millimetre, or about  $1/100000$  in. This limit is always below the yield-point, and may on occasion be zero. On loading a bar above the yield-point, this point rises with the stress, and the rise continues for weeks, months, and possibly for years if the bar is left at rest under its load. On the other hand, when a bar is loaded beyond its true elastic limit, but below its yield-point, this limit rises, but reaches a maximum as the yield-point is approached, and then falls rapidly, reaching even to zero. On leaving the bar at rest under a stress exceeding that of its primitive breaking-

down point the elastic limit begins to rise again, and may, if left a sufficient time, rise to a point much exceeding its previous value.

A bar has two limits of elasticity, one for tension and one for compression. Bauschinger loaded a number of bars in tension until stress ceased to be sensibly proportional to deformation. The load was then removed and the bar tested in compression until the elastic limit in this direction had been exceeded. This process raises the elastic limit in compression, as would be found on testing the bar in compression a second time. In place of this, however, it was now again tested in tension, when it was found that the artificial raising of the limit in compression had lowered that in tension below its previous value. By repeating the process of alternately testing in tension and compression, the two limits took up points at equal distances from the line of no load, both in tension and compression. These limits Bauschinger calls natural elastic limits of the bar, which for wrought iron correspond to a stress of about  $8\frac{1}{2}$  tons per square inch, but this is practically the limiting load to which a bar of the same material can be strained alternately in tension and compression, without breaking when the loading is repeated sufficiently often, as determined by Wöhler's method.

As received from the rolls the elastic limit of the bar in tension is above the natural elastic limit of the bar as defined by Bauschinger, having been artificially raised by the deformations to which it has been subjected in the process of manufacture. Hence, when subjected to alternating stresses, the limit in tension is immediately lowered, while that in compression is raised until they both correspond to equal loads. Hence, in Wöhler's experiments, in which the bars broke at loads nominally below the elastic limits of the material, there is every reason for concluding that the loads were really greater than true elastic limits of the material. This is confirmed by tests on the connecting-rods of engines, which work under alternating stresses of equal intensity. Careful experiments on old rods show that the elastic limit in compression is the same as that in tension, and that both are far below the tension elastic limit of the material as received from the rolls.

The common opinion that straining a metal beyond its elastic limit injures it appears to be untrue. It is not the mere straining of a metal beyond one elastic limit that injures it, but the straining, many times repeated, beyond its two elastic limits. Sir Benjamin Baker has shown that in bending a shell plate for a boiler the metal is of necessity strained beyond its elastic limit, so that stresses of as much as 7 tons to 15 tons per square inch may obtain in it as it comes from the rolls, and unless the plate is annealed, these stresses will still exist after it has been built into the boiler. In such a case, however, when exposed to the additional stress due to the pressure inside the boiler, the overstrained portions of the plate will relieve themselves by stretching and taking a permanent set, so that probably after a year's working very little difference could be detected in the stresses in a plate built into the boiler as it came from the bending rolls, and in one which had been annealed, before riveting into place, and the first, in spite of its having been strained beyond its elastic limits, and not subsequently annealed, would be as strong as the other.

### Resistance of Metals to Repeated Shocks.

More than twelve years were spent by Wöhler at the instance of the Prussian Government in experimenting upon the resistance of iron and steel to repeated stresses. The results of his experiments are expressed in what is known as Wöhler's law, which is given in the following words in Dubois's translation of Weyrauch:

"Rupture may be caused not only by a steady load which exceeds the carrying strength, but also by repeated applications of stresses, none of which are equal to the carrying strength. The differences of these stresses are measures of the disturbance of continuity, in so far as by their increase the minimum stress which is still necessary for rupture diminishes."

A practical illustration of the meaning of the first portion of this law may be given thus: If 50,000 pounds once applied will just break a bar of iron or steel, a stress very much less than 50,000 pounds will break it if repeated sufficiently often.

This is fully confirmed by the experiments of Fairbairn and Spangenberg, as well as those of Wöhler; and, as is remarked by Weyrauch, it may be considered as a long-known result of common experience. It partially accounts for what Mr. Holley has called the "intrinsically ridiculous factor of safety of six."

Another "long-known result of experience" is the fact that rupture may be caused by a succession of *shocks* or *impacts*, none of which alone would be sufficient to cause it. Iron axles, the piston-rods of steam hammers, and other pieces of metal subject to continuously repeated shocks, invariably break after a certain length of service. They have a "life" which is limited.

Several years ago Fairbairn wrote: "We know that in some cases wrought iron subjected to continuous vibration assumes a crystalline structure, and that the cohesive powers are much deteriorated, but we are ignorant of the causes of this change." We are still ignorant, not only of the causes of this change, but of the conditions under which it takes place. Who knows whether wrought iron subjected to very slight continuous vibration will endure forever? or whether to insure final rupture each of the continuous small shocks must amount at least to a certain percentage of single heavy shock (both measured in foot-pounds), which would cause rupture with one application? Wöhler found in testing iron by repeated stresses (not impacts) that in one case 400,000 applications of a stress of 500 centners to the square inch caused rupture, while a similar bar remained sound after 48,000,000 applications of a stress of 300 centners to the square inch (1 centner = 110.2 lbs.).

Who knows whether or not a similar law holds true in regard to repeated shocks? Suppose that a bar of iron would break under a single impact of 1000 foot-pounds, how many times would it be likely to bear the repetition of 100 foot-pounds, or would it be safe to allow it to remain for fifty years subjected to a continual succession of blows of even 10 foot-pounds each?

Mr. William Metcalf published in the *Metallurgical Review*, Dec., 1877, the results of some tests of the life of steel of different percentages of carbon under impact. Some small steel pitmans were made, the specifications for which required that the unloaded machine should run  $4\frac{1}{2}$  hours at the rate of 1200 revolutions per minute before breaking.

The steel was all of uniform quality, except as to carbon. Here are the results. The

0.30 C.	ran	1 h. 21 m.	Heated and bent before breaking.
0.49 C.	"	1 h. 28 m.	" " " " " "
0.53 C.	"	4 h. 57 m.	Broke without heating.
0.65 C.	"	3 h. 50 m.	Broke at weld where imperfect.
0.80 C.	"	5 h. 40 m.	
0.84 C.	"	18 h.	
0.87 C.			Broke in weld near the end.
0.96 C.			Ran 4.55 m., and the machine broke down.

Some other experiments by Mr. Metcalf confirmed his conclusion, viz. that high-carbon steel was better adapted to resist repeated shocks and vibrations than low-carbon steel.

These results, however, would scarcely be sufficient to induce any engineer to use 0.84 carbon steel in a car-axle or a bridge-rod. Further experiments are needed to confirm or overthrow them.

(See description of proposed apparatus for such an investigation in the author's paper in *Trans. A. I. M. E.*, vol. viii, p. 76, from which the above extract is taken.)

**Effect of Vibration and Load on Steel.** (Prof. P. R. Alger, U. S. Navy, *U. S. Naval Inst. Proc.*, Dec., 1910.)—In 1883, or thereabouts, a test of the theory that guns are weakened by the shock and vibration of repeated firing was made at the Washington Navy Yard as follows: Heavy weights, sufficient to strain the wire nearly to its elastic limit, were suspended by pieces of wire, and small hammers were arranged so that, actuated by the machinery of the shop, they struck the taut wires at regular and frequent intervals. After months of constant vibration, all the time under severe strain, the wires, when tested, showed unchanged physical qualities. Moreover, every gun, army and navy, that has suffered accident, since we first began to build



steel guns, has had the metal of the part that failed tested, and never has there been a case when any material difference was found between the physical qualities shown by the last tests and those shown by the original tests for acceptance. One of these guns, a 12-in., had been fired 481 rounds when its muzzle was blown off. (The fact stated in the last sentence tends to confirm the "theory" that guns are weakened by repeated firing, although the weakening may not be discovered by physical tests.)

### Stresses Produced by Suddenly Applied Forces and Shocks.

(Mansfield Merriman, *R. R. & Eng. Jour.*, Dec., 1889.)

Let  $P$  be the weight which is dropped from a height  $h$  upon the end of a bar, and let  $y$  be the maximum elongation which is produced. The work performed by the falling weight, then, is  $W = P(h + y)$ , and this must equal the internal work of the resisting molecular stresses. The stress in the bar, which is at first 0, increases up to a certain limit  $Q$ , which is greater than  $P$ ; and if the elastic limit be not exceeded the elongation increases uniformly with the stress, so that the internal work is equal to the mean stress  $\frac{1}{2} Q$  multiplied by the total elongation  $y$ , or  $W = \frac{1}{2} Qy$ . Whence, neglecting the work that may be dissipated in heat,

$$\frac{1}{2} Qy = Ph + Py.$$

If  $e$  be the elongation due to the static load  $P$ , within the elastic limit  $y = \frac{Q}{P} e$ ; whence  $Q = P \left( 1 + \sqrt{1 + 2\frac{h}{e}} \right)$ , which gives the momentary maximum stress. Substituting this value of  $Q$ , there results  $y = e \left( 1 + \sqrt{1 + 2\frac{h}{e}} \right)$ , which is the value of the momentary maximum elongation.

A shock results when the force  $P$ , before its action on the bar, is moving with velocity, as is the case when a weight  $P$  falls from a height  $h$ . The above formulas show that this height  $h$  may be small if  $e$  is a small quantity, and yet very great stresses and deformations be produced. For instance, let  $h = 4e$ , then  $Q = 4P$  and  $y = 4e$ ; also let  $h = 12e$ , then  $Q = 6P$  and  $y = 6e$ . Or take a wrought-iron bar 1 in. square and 5 ft. long; under a steady load of 5000 lbs. this will be compressed about 0.012 in., supposing that no lateral flexure occurs; but if a weight of 5000 lbs. drops upon its end from the small height of 0.048 in. there will be produced the stress of 20,000 lbs.

A suddenly applied force is one which acts with the uniform intensity  $P$  upon the end of the bar, but which has no velocity before acting upon it. This corresponds to the case of  $h = 0$  in the above formulas, and gives  $Q = 2P$  and  $y = 2e$  for the maximum stress and maximum deformation. Probably the action of a rapidly moving train upon a bridge produces stresses of this character. For a further discussion of this subject, in which the inertia of the bar is considered, see Merriman's *Mechanics of Materials*, 10th ed., 1908.

## TENSILE STRENGTH.

The following data are usually obtained in testing by tension in a testing-machine a sample of a material of construction:

The load and the amount of extension at the elastic limit.

The maximum load applied before rupture.

The elongation of the piece, measured between gauge-marks placed a stated distance apart before the test; and the reduction of area at the point of fracture.

The load at the elastic limit and the maximum load are recorded in pounds per square inch of the original area. The elongation is recorded as a percentage of the stated length between the gauge-marks, and the reduction of area as a percentage of the original area. The coefficient of elasticity is calculated from the ratio the extension within the elastic



limit per inch of length bears to the load per square inch producing that extension.

On account of the difficulty of making accurate measurements of the fractured area of a test-piece, and of the fact that elongation is more valuable than reduction of area as a measure of ductility and of resilience or work of resistance before rupture, modern experimenters are abandoning the custom of reporting reduction of area. The data now calculated from the results of a tensile test for commercial purposes are: 1. Tensile strength in pounds per square inch of original area. 2. Elongation per cent of a stated length between gauge-marks, usually 8 inches. 3. Elastic limit in pounds per square inch of original area.

The short or grooved test specimen gives with most metals, especially with wrought iron and steel, an apparent tensile strength much higher than the real strength. This form of test-piece is now almost entirely abandoned. Pieces 2 in. in length between marks are used for forgings.

The following results of the tests of six specimens from the same 1/4-in. steel bar illustrate the apparent elevation of elastic limit and the changes in other properties due to change in length of stems which were turned down in each specimen to 0.798 in. diameter. (Jas. E. Howard, Eng. Congress 1893, Section G.)

Description of Stem.	Elastic Limit, Lbs. per Sq. In.	Tensile Strength, Lbs. per Sq. In.	Contraction of Area, per cent.
1.00 in. long.....	64,900	94,400	49.0
0.50 in. long.....	65,320	97,800	43.4
0.25 in. long.....	68,000	102,420	39.6
Semicircular groove, 0.4 in. radius.....	75,000	116,380	31.6
Semicircular groove, 1/8 in. radius.....	86,000, about	134,960	23.0
V-shaped groove.....	90,000, about	117,000	Indeterminate.

Test plates made by the author in 1879 of straight and grooved test-pieces of boiler-plate steel cut from the same gave the following results:

5 straight pieces, 56,605 to 59,012 lbs. T. S. Aver. 57,566 lbs.  
 4 grooved " 64,341 to 67,400 " " " 65,452 "

Excess of the short or grooved specimen, 21 per cent, or 12,114 lbs.

**Measurement of Elongation.** — In order to be able to compare records of elongation, it is necessary not only to have a uniform length of section between gauge-marks (say 8 inches), but to adopt a uniform method of measuring the elongation to compensate for the difference between the apparent elongation when the piece breaks near one of the gauge-marks, and when it breaks midway between them. The following method is recommended (*Trans. A. S. M. E.*, vol. xi, p. 622):

Mark on the specimen divisions of 1/2 inch each. After fracture measure from the point of fracture the length of 8 of the marked spaces on each fractured portion (or 7 + on one side and 8 + on the other if the fracture is not at one of the marks). The sum of these measurements, less 8 inches, is the elongation of 8 inches of the original length. If the fracture is so near one end of the specimen that 7 + spaces are not left on the shorter portion, then take the measurement of as many spaces (with the fractional part next to the fracture) as are left, and for the spaces lacking add the measurement of as many corresponding spaces of the longer portion as are necessary to make the 7 + spaces.

**Precautions Required in making Tensile Tests.** — The testing-machine itself should be tested, to determine whether its weighing apparatus is accurate, and whether it is so made and adjusted that in the test of a properly made specimen the line of strain of the testing-machine is absolutely in line with the axis of the specimen.

The specimen should be so shaped that it will not give an incorrect record of strength.

It should be of uniform minimum section for not less than eight inches of its length. Eight inches is the standard length for bars. For forgings and castings and in special cases shorter lengths are used; these show greater percentages of elongation, and the length between gauge marks should therefore always be stated in the record.

Regard must be had to the time occupied in making tests of certain materials. Wrought iron and soft steel can be made to show a higher than their actual apparent strength by keeping them under strain for a great length of time.

In testing soft alloys, copper, tin, zinc, and the like, which flow under constant strain, their highest apparent strength is obtained by testing them rapidly. In recording tests of such materials the length of time occupied in the test should be stated.

For very accurate measurements of elongation, corresponding to increments of load during the tests, the electric contact micrometer, described in *Trans. A. S. M. E.*, vol. vi. p. 479, will be found convenient. When readings of elongation are then taken during the test, a strain diagram may be plotted from the reading, which is useful in comparing the qualities of different specimens. Such strain diagrams are made automatically by the new Olsen testing-machine, described in *Jour. Frank. Inst.* 1891.

The coefficient of elasticity should be deduced from measurement observed between fixed increments of load per unit section, say between 2000 and 12,000 pounds per square inch or between 1000 and 11,000 pounds instead of between 0 and 10,000 pounds.

**Shapes of Specimens for Tensile Tests.** — The shapes shown below were recommended by the author in 1882 when he was connected with the Pittsburgh Testing Laboratory. They are now in most general use; the earlier forms, with 5 inches or less in length between shoulders, being almost entirely abandoned.

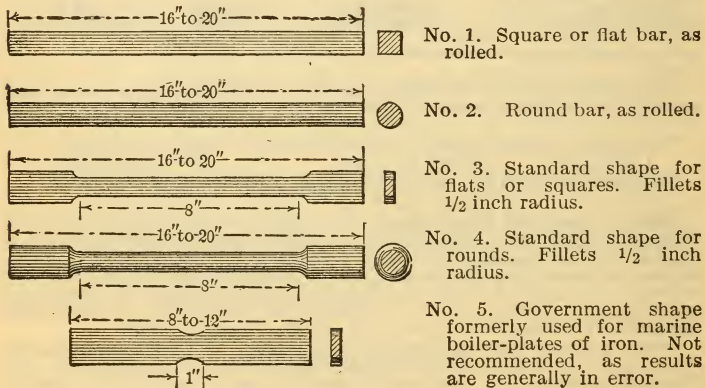

**Increasing the Tensile Strength of Iron Bars by Twisting them.** — Ernest L. Ransome of San Francisco obtained a patent, in 1888, for an "improvement in strengthening and testing wrought metal and steel rods or bars, consisting in twisting the same in a cold state. . . . Any defect in the lamination of the metal which would otherwise be concealed is revealed by twisting, and imperfections are shown at once. The treatment may be applied to bolts, suspension-rods or bars subjected to tensile strength of any description."

Jesse J. Shuman (*Am. Soc. Test. Mat.*, 1907) describes several series of

experiments on the effect of twisting square steel bars. Following are some of the results:

Soft Bessemer steel bars $\frac{1}{2}$ in. square. Tens. Strength, plain bar, 60,400.	
No. of turns per foot.....	3 $4\frac{3}{4}$ 5 $5\frac{3}{4}$ $5\frac{7}{8}$
Yield point, lbs. per sq. in.....	65,600    72,400    84,800    84,000    80,800
Ult. strength " " " " .....	83,200    89,600    92,000    90,000    88,800
Elongation in 8 in., % .....	10      5.75      6.25      7.5      3.75

Bessemer, 0.25 carbon, $\frac{1}{2}$ in. sq. Tens. strength, plain bar, 75,000.	
No. of turns per foot .....	3 $4\frac{1}{2}$ $4\frac{7}{8}$ 5 $5\frac{1}{2}$
Yield point, lbs. per sq. in.....	83,600    83,200    88,800    84,200    84,200
Ult. strength " " " " .....	99,600    99,200    104,000    102,000    100,800
Elongation in 8 in., % .....	8      4.5      4      5.75      6

Bars of each grade twisted off when given more turns than stated.

Soft Bessemer, square bars, different sizes.

Size, in. sq.....	$\frac{1}{4}$	$\frac{3}{8}$	$\frac{1}{2}$	$\frac{5}{8}$	$\frac{3}{4}$	$\frac{7}{8}$	1	$1\frac{1}{8}$	$1\frac{1}{4}$
No. of turns per ft.....	4	$3\frac{1}{2}$	3	$2\frac{1}{4}$	$1\frac{1}{2}$	$1\frac{1}{4}$	1	$\frac{7}{8}$	$\frac{3}{4}$
Yield point, increase %* .....	111	82	64	83	85.5	77	82	64	59
Ult. strength " " %* .....	37	38.6	41	33.5	34.3	29.7	22.8	20.1	28.9

\* Average of two tests each.

Mr. Schuman recommends that in twisting bars for reinforced concrete, in order not to be in danger of approaching the breaking point, the number of turns should be about half the number at which the steel is at its maximum strength, which for Bessemer of about 60,000 lbs. tensile strength means one complete twist in 8 to 10 times the size of the bar.

Steel bars strengthened by twisting are largely used in reinforced concrete.

COMPRESSIVE STRENGTH.

What is meant by the term "compressive strength" has not yet been settled by the authorities, and there exists more confusion in regard to this term than in regard to any other used by writers on strength of materials. The reason of this may be easily explained. The effect of a compressive stress upon a material varies with the nature of the material, and with the shape and size of the specimen tested. While the effect of a tensile stress is to produce rupture or separation of particles in the direction of the line of strain, the effect of a compressive stress on a piece of material may be either to cause it to fly into splinters, to separate into two or more wedge-shaped pieces and fly apart, to bulge, buckle, or bend, or to flatten out and utterly resist rupture or separation of particles. A piece of speculum metal (copper 2, tin 1) under compressive stress will exhibit no change of appearance until rupture takes place, and then it will fly to pieces as suddenly as if blown apart by gunpowder. A piece of cast iron or of stone will generally split into wedge-shaped fragments. A piece of wrought iron will buckle or bend. A piece of wood or zinc may bulge, but its action will depend upon its shape and size. A piece of lead will flatten out and resist compression till the last degree; that is, the more it is compressed the greater becomes its resistance.

Air and other gaseous bodies are compressible to any extent as long as they retain the gaseous condition. Water not confined in a vessel is compressed by its own weight to the thickness of a mere film, while when confined in a vessel it is almost incompressible.

It is probable, although it has not been determined experimentally, that solid bodies when confined are at least as incompressible as water. When they are not confined, the effect of a compressive stress is not only to shorten them, but also to increase their lateral dimensions or bulge them. Lateral stresses are therefore induced by compressive stresses.

The weight per square inch of original section required to produce any given amount or percentage of shortening of any material is not a constant quantity, but varies with both the length and the sectional area, with the shape of the sectional area, and with the relation of the area to the length. The "compressive strength" of a material, if this term be supposed to mean the weight in pounds per square inch necessary to cause rupture, may vary with every size and shape of specimen experimented upon.



Still more difficult would it be to state what is the "compressive strength" of a material which does not rupture at all, but flattens out. Suppose we are testing a cylinder of a soft metal like lead, two inches in length and one inch in diameter, a certain weight will shorten it one per cent, another weight ten per cent, another fifty per cent, but no weight that we can place upon it will rupture it, for it will flatten out to a thin sheet. What, then, is its compressive strength? Again, a similar cylinder of soft wrought iron would probably compress a few per cent, bulging evenly all around; it would then commence to bend, but at first the bend would be imperceptible to the eye and too small to be measured. Soon this bend would be great enough to be noticed, and finally the piece might be bent nearly double, or otherwise distorted. What is the "compressive strength" of this piece of iron? Is it the weight per square inch which compresses the piece one per cent or five per cent, that which causes the first bending (impossible to be discovered), or that which causes a perceptible bend?

As showing the confusion concerning the definitions of compressive strength, the following statements from different authorities on the strength of wrought iron are of interest.

Wood's Resistance of Materials states, "Comparatively few experiments have been made to determine how much wrought iron will sustain at the point of crushing. Hodgkinson gives 65,000, Rondulet 70,800, Weisbach 72,000, Rankine 30,000 to 40,000. It is generally assumed that wrought iron will resist about two thirds as much crushing as to tension, but the experiments fail to give a very definite ratio."

The following values, said to be deduced from the experiments of Major Wade, Hodgkinson, and Capt. Meigs, are given by Haswell:

American wrought iron	.....	127,720 lbs.
"    "    "    (mean)	.....	85,500 "
English    "    "	.....	65,200 "
		40,000 "

Stoney states that the strength of short pillars of any given material, all having the same diameter, does not vary much, provided the length of the piece is not less than one and does not exceed four or five diameters, and that the weight which will just crush a short prism whose base equals one square inch, and whose height is not less than 1 to  $1\frac{1}{2}$  and does not exceed 4 or 5 diameters, is called the crushing strength of the material. It would be well if experimenters would all agree upon some such definition of the term "crushing strength," and insist that all experiments which are made for the purpose of testing the relative values of different materials in compression be made on specimens of exactly the same shape and size. An arbitrary size and shape should be assumed and agreed upon for this purpose. The size mentioned by Stoney is definite as regards area of section, viz., one square inch, but is indefinite as regards length, viz., from one to five diameters. In some metals a specimen five diameters long would bend, and give a much lower apparent strength than a specimen having a length of one diameter. The words "will just crush" are also indefinite for ductile materials, in which the resistance increases without limit if the piece tested does not bend. In such cases the weight which causes a certain percentage of compression, as five, ten, or fifty per cent, should be assumed as the crushing strength.

For future experiments on crushing strength three things are desirable: First, an arbitrary standard shape and size of test specimen for comparison of all materials. Secondly, a standard limit of compression for ductile materials, which shall be considered equivalent to fracture in brittle materials. Thirdly, an accurate knowledge of the relation of the crushing strength of a specimen of standard shape and size to the crushing strength of specimens of all other shapes and sizes. The latter can only be secured by a very extensive and accurate series of experiments upon all kinds of materials, and on specimens of a great number of different shapes and sizes.

The author proposes, as a standard shape and size, for a compressive



test specimen for all metals, a cylinder one inch in length, and one half square inch in sectional area, or 0.798 inch diameter; and for the limit of compression equivalent to fracture, ten per cent of the original length. The term "compressive strength," or "compressive strength of standard specimen," would then mean the weight per square inch required to fracture by compressive stress a cylinder one inch long and 0.798 inch diameter, or to reduce its length to 0.9 inch if fracture does not take place before that reduction in length is reached. If such a standard, or any standard size whatever, had been used by the earlier authorities on the strength of materials, we never would have had such discrepancies in their statements in regard to the compressive strength of wrought iron as those given above.

The reasons why this particular size is recommended are: that the sectional area, one-half square inch, is as large as can be taken in the ordinary testing-machines of 100,000 pounds capacity, to include all the ordinary metals of construction, cast and wrought iron, and the softer steels; and that the length, one inch, is convenient for calculation of percentage of compression. If the length were made two inches, many materials would bend in testing, and give incorrect results. Even in cast iron Hodgkinson found as the mean of several experiments on various grades, tested in specimens  $\frac{3}{4}$  inch in height, a compressive strength per square inch of 94,730 pounds, while the mean of the same number of specimens of the same irons tested in pieces  $1\frac{1}{2}$  inches in height was only 88,800 pounds. The best size and shape of standard specimen should, however, be settled upon only after consultation and agreement among several authorities.

The Committee on Standard Tests of the American Society of Mechanical Engineers say (vol. xi, p. 624):

"Although compression tests have heretofore been made on diminutive sample pieces, it is highly desirable that tests be also made on long pieces from 10 to 20 diameters in length, corresponding more nearly with actual practice, in order that elastic strain and change of shape may be determined by using proper measuring apparatus.

"The elastic limit, modulus or coefficient of elasticity, maximum and ultimate resistances, should be determined, as well as the increase of section at various points, viz., at bearing surfaces and at crippling point.

"The use of long compression-test pieces is recommended, because the investigation of short cubes or cylinders has led to no direct application of the constants obtained by their use in computation of actual structures, which have always been and are now designed according to empirical formulæ obtained from a few tests of long columns."

COLUMNS, PILLARS, OR STRUTS.

*Notation.* —  $P$  = crushing weight in pounds;  $d$  = exterior diameter in inches;  $a$  = area in square inches;  $L$  = length in feet;  $l$  = length in inches;  $S$  = compressive stress, lbs. per sq. in.;  $E$  = modulus of elasticity in tension or compression;  $r$  = least radius of gyration;  $\phi$ , an experimental coefficient.

For a short column centrally loaded  $S = P/a$ , but for a long column which tends to bend under load, the stress on the concave side is greater, and on the convex side less than  $P/a$ .

Hodgkinson's Formula for Columns.

Kind of Column.	Both ends rounded, the length of the column exceeding 15 times its diameter.	Both ends flat, the length of the column exceeding 30 times its diameter.
Solid cylindrical columns of cast iron . . . }	$P = 33,380 \frac{d^{3.76}}{L^{1.7}}$	$P = 98,920 \frac{d^{3.55}}{L^{1.7}}$
Solid cylindrical columns of wrought iron }	$P = 95,850 \frac{d^{3.76}}{L^2}$	$P = 299,600 \frac{d^{3.55}}{L^2}$

These formulæ apply only in cases in which the length is so great that

the column breaks by bending and not by simple crushing. Hodgkinson's tests were made on small columns, and his results are not now considered reliable.

### Euler's Formula for Long Columns.

$P/a = \pi^2 E (r/l)^2$  for columns with round or hinged ends. For columns with fixed ends, multiply by 4; with one end round and the other fixed, multiply by  $2^{1/4}$ ; for one end fixed and the other free, as a post set in the ground, divide by 4.  $P$  is the load which causes a slight deflection; a load greater than  $P$  will cause an increase of deflection until the column fails by bending. The formula is now little used.

**Christie's Tests** (*Trans. A. S. C. E.* 1884; *Merriman's Mechanics of Materials*). — About 300 tests of wrought-iron struts were made, the quality of the iron being about as follows: tensile strength per sq. in., 49,600 lbs., elastic limit 32,000 lbs., elongation 18% in 8 ins.

The following table gives the average results.

Ratio $l/r$ Length to Least Ra- dius of Gyration.	Ultimate Load, $P/a$ , in Pounds per Square Inch.			
	Fixed Ends.	Flat Ends.	Hinged Ends.	Round Ends.
20	46,000	46,000	46,000	44,000
40	40,000	40,000	40,000	36,500
60	36,000	36,000	36,000	30,500
80	32,000	32,000	31,500	25,000
100	30,000	29,800	28,000	20,500
120	28,000	26,300	24,300	16,500
140	25,500	23,500	21,000	12,800
160	23,000	20,000	16,500	9,500
180	20,000	16,800	12,800	7,500
200	17,500	14,500	10,800	6,000
220	15,000	12,700	8,800	5,000
240	13,000	11,200	7,500	4,300
260	11,000	9,800	6,500	3,800
280	10,000	8,500	5,700	3,200
300	9,000	7,200	5,000	2,800
320	8,000	6,000	4,500	2,500
360	6,500	4,300	3,500	1,900
400	5,200	3,000	2,500	1,500

The results of Christie's tests agree with those computed by Euler's formula for round-end columns with  $l/r$  between 150 and 400, but differ widely from them in shorter columns, and still more widely in columns with fixed ends.

**Rankine's Formula** (sometimes called Gordon's),  $S = \frac{P}{a} \left( 1 + \phi \left( \frac{l}{r} \right)^2 \right)$   
 or  $\frac{P}{a} = \frac{S}{1 + \phi (l/r)^2}$ . Applying Rankine's formula to the results of experiments, wide variations are found in the values of the empirical coefficient  $\phi$ . Merriman gives the following values, which are extensively employed in practice.

### VALUES OF $\phi$ FOR RANKINE'S FORMULA.

Material.	Both Ends Fixed.	Fixed and Round.	Both Ends Round.
Timber.....	1/3,000	1.78/3,000	4/3,000
Cast Iron.....	1/5,000	1.78/5,000	4/5,000
Wrought Iron.....	1/36,000	1.78/36,000	4/36,000
Steel.....	1/25,000	1.78/25,000	4/25,000

The value to be taken for  $S$  is the ultimate compressive strength of the

material for cases of rupture, and the allowable compressive unit stress for cases of design.

Burr gives the following values as commonly taken for  $S$  and  $\phi$ .

For solid wrought-iron columns,  $S = 36,000$  to  $40,000$ ,  $\phi = 1/36,000$  to  $1/40,000$ .

For solid cast-iron columns,  $S = 80,000$ ,  $\phi = 1/6,400$ .

For hollow cast-iron columns,  $P/a = 80,000 \div 1 + \frac{1}{800} \frac{l^2}{d^2}$  ( $d =$  outside diam. in inches).

The coefficient of  $l^2/d^2$  is given by different writers as  $1/400$ ,  $1/500$ ,  $1/600$  and  $1/800$ . (See Strength of Cast-iron Columns, below.)

Sir Benjamin Baker gives for mild steel,  $S = 67,000$  lbs.,  $\phi = 1/22,400$ ; for strong steel,  $S = 114,000$  lbs.,  $\phi = 1/14,400$ . Prof. Burr considers these only loose approximations. (See Straight-line Formula, below).

For dry timber, Rankine gives  $S = 7200$  lbs.,  $\phi = 1/3000$ .

**The Straight-line Formula.**—The results of computations by Euler's or Rankine's formulas give a curved line when plotted on a diagram with values of  $l/r$  as abscissas and value of  $P/a$  as ordinates. The average results of experiments on columns within the limits of  $l/r$  commonly used in practice, say from 50 to 200, can be represented by a straight line about as accurately as by a curve. Formulas derived from such plotted lines, of the general form  $P/a = S - Cl/r$ , in which  $C$  is an experimental coefficient, are in common use, but Merriman says it is advisable that the use of this formula should be limited to cases in which the specifications require it to be employed, and for rough approximate computations. Values of  $S$  and  $C$  given by T. H. Johnson are as follows:

	F	H	R		F	H	R
Wrought Iron:	$S = 42,000$ lbs., $C = 128, 157, 203$ ; limit of $l/r = 218, 178, 138$						
Structural Steel:	$S = 52,500$ " $C = 179, 220, 284$ ; " " "				195, 159, 123		
Cast Iron:	$S = 80,000$ " $C = 438, 537, 693$ ; " " "				122, 99, 77		
Oak, flat ends:	$S = 5,400$ " $C = 28$ ;				" " " 128		

$F$ , flat ends;  $H$ , hinged ends;  $R$ , round ends.

Merriman says: "The straight-line formula is not suitable for investigating a column, that is for determining values of  $S$  due to given loads, because  $S$  enters the formula in such a manner as to lead to a cubic equation when it is the only unknown quantity. It may be used to find the safe load for a given column to withstand a given unit stress, or to design a column for a given load and unit stress. When so used, it is customary to divide the values of  $S$  and  $C$  given in the table by an assumed factor of safety. For example, Cooper's specifications require that the sectional area  $a$  for a medium-steel post of a through railroad bridge shall be found from  $P/a = 17,000 - 90 l/r$  lbs. per sq. in., in which  $P$  is the direct dead-load compression on the post plus twice the live-load compression; the values of  $S$  and  $C$  here used are a little less than one-third of those given in the table for round ends."

**Working Formulæ for Wrought-iron and Steel Struts of Various Forms.**—Burr gives the following practical formulæ:

Kind of Strut.	$p =$ Ultimate Strength, lbs. per sq. in. of Section.	$p_1 =$ Working Strength = $1/5$ Ultimate, lbs. per sq. in. of Section.
Flat and fixed end iron angles and tees	$44000 - 140 \frac{l}{r}$ (1)	$8800 - 28 \frac{l}{r}$ (2)
Hinged-end iron angles and tees . . . . .	$46000 - 175 \frac{l}{r}$ (3)	$9200 - 35 \frac{l}{r}$ (4)
Flat-end iron channels and I-beams . . . . .	$40000 - 110 \frac{l}{r}$ (5)	$8000 - 22 \frac{l}{r}$ (6)



Flat-end mild-steel angles.....52000 - 180  $\frac{l}{r}$  (7) 10400 - 36  $\frac{l}{r}$  (8)

Flat-end high-steel angles.....76000 - 290  $\frac{l}{r}$  (9) 15200 - 58  $\frac{l}{r}$  (10)

Pin-end solid wrought-iron columns... 32000 - 80  $\frac{l}{r}$  } (11) 6400 - 16  $\frac{l}{r}$  } (12)  
 32000 - 277  $\frac{l}{d}$  } 6400 - 55  $\frac{l}{d}$  }

Equations (1) to (4) are to be used only between  $\frac{l}{r} = 40$  and  $\frac{l}{r} = 200$

" (5) and (6) " " " " " " " " = 20 " " = 200  
 " (7) to (10) " " " " " " " " = 40 " " = 200  
 " (11) and (12) " " " " " " " " = 20 " " = 200

or  $\frac{l}{d} = 6$  and  $\frac{l}{d} = 65$

**Comparison of Column Compression Formulæ.**—The Carnegie Steel Co. gives in its Pocket Companion (1913) a table comparing the allowable unit stresses in columns calculated from the formulæ of the American Bridge Co., American Railway Engineering Association, Gordon, and the New York, Philadelphia, and Boston Building Laws, for various values of  $l/r$ . The table below is condensed from this table and compares the values obtained by the American Bridge Co. formula with the average of all those, except that of the American Bridge Co. for values of  $l/r$  up to 120, and with the values obtained by Gordon's formula for values of  $l/r$  from 125 to 200.

**Allowable Unit Stresses—Pounds per Sq. In.**

$l/r$	Am. Bridge Co.	Average.	$l/r$	Am. Bridge Co.	Average.	$l/r$	Am. Bridge Co.	Gordon.
0	14,000	14,790	65	11,450	11,803	125	6,750	8,715
5	14,000	14,719	70	11,100	11,466	130	6,500	8,510
10	14,000	14,620	75	10,750	11,130	135	6,250	8,300
15	14,000	14,499	80	10,400	10,794	140	6,000	8,095
20	14,000	14,355	85	10,050	10,459	145	5,750	7,890
25	14,000	14,185	90	9,700	10,127	150	5,500	7,690
30	13,900	13,977	95	9,350	9,785	155	5,250	7,495
35	13,550	13,701	100	9,000	9,473	160	5,000	7,305
40	13,200	13,410	105	8,650	9,150	165	4,750	7,120
45	12,850	13,106	110	8,300	8,837	170	4,500	6,935
50	12,500	12,790	115	7,950	8,528	180	4,000	6,580
55	12,150	12,467	120	7,600	8,221	190	3,500	6,240
60	11,800	12,137				200	3,000	5,920

**Built Columns (Burr).**—Steel columns, properly made, of steel ranging in specimens from 65,000 to 73,000 lbs. per square inch, should give a resistance 25 to 33 per cent in excess of that of wrought-iron columns with the same value of  $l \div r$ , provided that ratio does not exceed 140.

The unsupported width of a plate in a compression member should not exceed 30 times its thickness.

In built columns the transverse distance between centre lines of rivets securing plates to angles or channels, etc., should not exceed 35 times the plate thickness. If this width is exceeded, longitudinal buckling of the plate takes place, and the column ceases to fail as a whole, but yields in detail.

The thickness of the leg of an angle to which latticing is riveted should not be less than  $\frac{1}{9}$  of the length of that leg or side if the column is purely a compression member. The above limit may be passed somewhat in stiff ties and compression members designed to carry transverse loads.

The panel points of latticing should not be separated by a greater dis-



tance than 60 times the thickness of the angle-leg to which the latticing is riveted, if the column is wholly a compression member.

The rivet pitch should never exceed 16 times the thickness of the thinnest metal pierced by the rivet, and if the plates are very thick it should never nearly equal that value.

Burr gives the following general principles which govern the resistance of built columns:

The material should be disposed as far as possible from the neutral axis of the cross-section, thereby increasing  $r$ ;

There should be no initial internal stress;

The individual portions of the column should be mutually supporting;

The individual portions of the column should be so firmly secured to each other that no relative motion can take place, in order that the column may fail as a whole, thus maintaining the original value of  $r$ .

Stoney says: "When the length of a rectangular wrought-iron tubular column does not exceed 30 times its least breadth, it fails by the bulging or buckling of a short portion of the plates, not by the flexure of the pillar as a whole."

**Tests of Five Large Built Steel Columns.** (*Proc. A. S. C. E.*, Feb., 1911; *Eng. News*, Mar. 16, 1911).—The lateral dimensions of the columns were about  $20 \times 30$  in., and their sectional area 90 sq. in. They were made of two ribs 30 in. deep, spaced  $20\frac{7}{8}$  in., laced by two lines of  $2\frac{1}{2} \times \frac{3}{8}$  in. lacing. Each rib was made of an outside plate,  $30 \times \frac{11}{16}$  in., and an inside plate,  $17\frac{1}{2} \times \frac{5}{8}$  in., and two inner edging angles,  $6 \times 6 \times \frac{5}{8}$  in. Transverse plate diaphragms, 6 ft. apart, gave additional lateral rigidity. The test columns were fitted with 10-in. pins set parallel to the plane of the lacing. The columns were tested in the 1,200-ton hydraulic machine at Phoenixville, Pa.; two of them (Nos. 1 and 2) did not reach failure. The results are as below:

No.	Section Area Sq. In.	Length Ft. In.	$l/r$	Max. Load Lb.	Lb. per Sq. In.
1.....	90.73	20 0	26.2	2,600,962	28,667
2.....	90.33	36 5	47.2	2,600,962	28,794
3.....	90.78	36 5	47.2	2,675,183	29,469
4.....	90.32	36 5	47.2	2,726,815	30,191
5.....	89.96	36 5	47.1	2,742,950	30,490

Nos. 3 and 4 failed by bulging of plates in front of pins; No. 5 by web-plates bulging inward  $12\frac{1}{2}$  in. from one end. The columns departed from strictly proportional compression at a load as low as 20,000 lb. per sq. in. Plotted curves of the tests show that all the columns reached their elastic limit at about this figure, and an ultimate strength at about 30,000 lb. per sq. in. *Eng. News* says that it does not appear that the lacing contributed to the failure. It shows that the compressive strength of these columns did not exceed 60% of the tensile strength of the metal.

**WORKING STRAINS ALLOWED IN BRIDGE MEMBERS.**

Theodore Cooper gives the following in his Bridge Specifications:

Compression members shall be so proportioned that the maximum load shall in no case cause a greater strain than that determined by the following formula:

$$P = \frac{8000}{1 + \frac{l^2}{40,000 r^2}} \text{ for square-end compression members;}$$

$$P = \frac{8000}{1 + \frac{l^2}{30,000 r^2}} \text{ for compression members with one pin and one square end;}$$

$$P = \frac{8000}{1 + \frac{l^2}{20,000 r^2}} \text{ for compression members with pin-bearings;}$$

(These values may be increased in bridges over 150 ft. span. See Cooper's Specifications.)

$P$  = the allowed compression per square inch of cross-section;

$l$  = the length of compression member, in inches;

$r$  = the least radius of gyration of the section in inches.

No compression member, however, shall have a length exceeding 25 times its least width.

*Tension Members.* — All parts of the structure shall be so proportioned that the maximum loads shall in no case cause a greater tension than the following (except in spans exceeding 150 feet):

	Pounds per sq. in.
On lateral bracing . . . . .	15,000
On solid rolled beams, used as cross floor-beams and stringers . . . .	9,000
On bottom chords and main diagonals (forged eye-bars) . . . . .	10,000
On bottom chords and main diagonals (plates or shapes), net section	8,000
On counter rods and long verticals (forged eye-bars) . . . . .	8,000
On counter and long verticals (plates or shapes), net section . . . .	6,500
On bottom flange of riveted cross-girders, net section . . . . .	8,000
On bottom flange of riveted longitudinal plate girders over 20 ft. long, net section . . . . .	8,000
On bottom flange of riveted longitudinal plate girders under 20 ft. long, net section . . . . .	7,000
On floor-beam hangers, and other similar members liable to sudden loading (bar iron with forged ends) . . . . .	6,000
On floor-beam hangers, and other similar members liable to sudden loading (plates or shapes), net section . . . . .	5,000

Members subject to alternate strains of tension and compression shall be proportioned to resist each kind of strain. Both of the strains shall, however, be considered as increased by an amount equal to  $\frac{8}{10}$  of the least of the two strains, for determining the sectional area by the above allowed strains.

The Phoenix Bridge Co. (Standard Specifications, 1895) gives the following:

The greatest working stresses in pounds per square inch shall be as follows:

		<i>Tension.</i>		
Steel.			Iron.	
$P=9,000$	$\left[1 + \frac{\text{Min. stress}}{\text{Max. stress}}\right]$	For bars, forged ends.	$P=7,500$	$\left[1 + \frac{\text{Min. stress}}{\text{Max. stress}}\right]$
$P=8,500$	$\left[1 + \frac{\text{Min. stress}}{\text{Max. stress}}\right]$	Plates or shapes net.	$P=7,000$	$\left[1 + \frac{\text{Min. stress}}{\text{Max. stress}}\right]$
8,500 pounds.		Floor-beam hangers, forged ends . . . . .	7,000 pounds.	
7,500 "		Floor-beam hangers, plates or shapes, net section . . . . .	6,000 "	
10,000 "		Lower flanges of rolled beams . . . . .	8,000 "	
20,000 "		Outside fibres of pins . . . . .	15,000 "	
30,000 "		Pins for wind-bracing . . . . .	22,500 "	
20,000 "		Lateral bracing . . . . .	15,000 "	

*Shearing.*

9,000 pounds.	Pins and rivets . . . . .	7,500 pounds.
	Hand-driven rivets 20% less unit stresses. For bracing increase unit stresses 50%.	
6,000 pounds.	Webs of plate girders . . . . .	5,000 pounds.

*Bearing.*

16,000 pounds. Projection semi-intrados pins and rivets, 12,000 pounds.  
Hand-driven rivets 20% less unit stresses. For  
bracing increase unit stresses 50%.

*Compression.*

Lengths less than forty times the least radius of gyration,  $P$  previously found. See Tension.

Lengths more than forty times the least radius of gyration,  $P$  reduced by following formulæ:

$$\text{For both ends fixed, } b = \frac{P}{1 + \frac{l^2}{36,000 r^2}}$$

$$\text{For one end hinged, } b = \frac{P}{1 + \frac{l^2}{24,000 r^2}}$$

$$\text{For both ends hinged, } b = \frac{P}{1 + \frac{l^2}{18,000 r^2}}$$

$P$  = permissible stress previously found (see Tension);  $b$  = allowable working stress per square inch;  $l$  = length of member in inches;  $r$  = least radius of gyration of section in inches. No compression member, however, shall have a length exceeding 45 times its least width.

Pounds per sq. in.

In counter web members . . . . .	10,500
In long verticals . . . . .	10,000
In all main-web and lower-chord eye-bars . . . . .	13,200
In plate hangers (net section) . . . . .	9,000
In tension members of lateral and transverse bracing . . . . .	19,000
In steel-angle lateral ties (net section) . . . . .	15,000

For spans over 200 feet in length the greatest allowed working stresses per square inch, in lower-chord and end main-web eye-bars, shall be taken at

$$10,000 \left( 1 + \frac{\text{min. total stress}}{\text{max. total stress}} \right)$$

whenever this quantity exceeds 13,200.

The greatest allowable stress in the main-web eye-bars nearest the centre of such spans shall be taken at 13,200 pounds per square inch; and those for the intermediate eye-bars shall be found by direct interpolation between the preceding values.

The greatest allowable working stresses in steel plate and lattice girders and rolled beams shall be taken as follows:

Pounds per sq. in.

Upper flange of plate girders (gross section) . . . . .	10,000
Lower flange of plate girders (net section) . . . . .	10,000
In counters and long verticals of lattice girders (net section) . . . . .	9,000
In lower chords and main diagonals of lattice girders (net section) . . . . .	10,000
In bottom flanges of rolled beams . . . . .	10,000
In top flanges of rolled beams . . . . .	10,000

**THE STRENGTH OF CAST-IRON COLUMNS.**

Hodgkinson's experiments (first published in Phil. Trans. Royal Socy., 1840, and condensed in Tredgold on Cast Iron, 4th ed., 1846), and Gordon's formula, based upon them, are still used (1898) in designing cast-iron columns. They are entirely inadequate as a basis of a practical formula suitable to the present methods of casting columns.

Hodgkinson's experiments were made on nine "long" pillars, about 71/2 ft. long, whose external diameters ranged from 1.74 to 2.23 in., and average thickness from 0.29 to 0.35 in., the thickness of each column also varying, and on 13 "short" pillars, 0.733 ft. to 2.251 ft. long, with exter-

nal diameters from 1.08 to 1.26 in., all of them less than  $\frac{1}{4}$  in. thick. The iron used was Low Moor, Yorkshire, No. 3, said to be a good iron, not very hard, earlier experiments on which had given a tensile strength of 14,535 and a crushing strength of 109,801 lbs. per sq. in. Modern cast-iron columns, such as are used in the construction of buildings, are very different in size, proportions, and quality of iron from the slender "long" pillars used in Hodgkinson's experiments. There is usually no check, by actual tests or by disinterested inspection, upon the quality of the material. The tensile, compressive, and transverse strength of cast iron varies through a great range (the tensile strength ranging from less than 10,000 to over 40,000 lbs. per sq. in.), with variations in the chemical composition of the iron, according to laws which are as yet very imperfectly understood, and with variations in the method of melting and of casting. There is also a wide variation in the strength of iron of the same melt when cast into bars of different thicknesses.

Another difficulty in obtaining a practical formula for the strength of cast-iron columns is due to the uncertainty of the quality of the casting, and the danger of hidden defects, such as internal stresses due to unequal cooling, cinder or dirt, blow-holes, "cold-shuts," and cracks on the inner surface, which cannot be discovered by external inspection. Variation in thickness, due to rising of the core during casting, is also a common defect.

In addition to these objections to the use of Gordon's formula, for cast-iron columns, we have the data of experiments on full-sized columns, made by the Building Department of New York City (*Eng'g News*, Jan. 13 and 20, 1898). Ten columns in all were tested, six 15-inch, 190 $\frac{1}{4}$  inches long, two 8-inch, 160 inches long, and two 6-inch, 120 inches long. The tests were made on the large hydraulic machine of the Phoenix Bridge Co., of 2,000,000 pounds capacity, which was calibrated for frictional error by the repeated testing within the elastic limit of a large Phoenix column, and the comparison of these tests with others made on the government machine at the Watertown Arsenal. The average frictional error was calculated to be 15.4 per cent, but *Engineering News*, revising the data, makes it 17.1 per cent, with a variation of 3 per cent either way from the average with different loads. The results of the tests of the columns are given below.

## TESTS OF CAST-IRON COLUMNS.

Num- ber.	Diam. Inches.	Thickness.			Breaking Load.	
		Max.	Min.	Average.	Pounds.	Pounds per Sq. In.
1	15	1	1	1	1,356,000	30,830
2	15	1 $\frac{5}{16}$	1	1 $\frac{1}{8}$	1,330,000	27,700
3	15	1 $\frac{1}{4}$	1	1 $\frac{1}{8}$	1,198,000	24,900
4	15 $\frac{1}{8}$	1 $\frac{7}{32}$	1	1 $\frac{1}{8}$	1,246,000	25,200
5	15	1 $\frac{11}{16}$	1	1 $\frac{11}{64}$	1,632,000	32,100
6	15	1 $\frac{1}{4}$	1 $\frac{1}{8}$	1 $\frac{3}{16}$	2,082,000 +	40,400 +
7	7 $\frac{3}{4}$ to 8 $\frac{1}{4}$	1 $\frac{1}{4}$	5 $\frac{1}{8}$	1	651,000	31,900
8	8	1 $\frac{3}{32}$	1	1 $\frac{3}{64}$	612,800	26,800
9	6 $\frac{1}{16}$	1 $\frac{5}{32}$	1 $\frac{1}{8}$	1 $\frac{9}{64}$	400,000	22,700
10	6 $\frac{3}{32}$	1 $\frac{1}{8}$	1 $\frac{1}{16}$	1 $\frac{7}{64}$	455,200	26,300

Column No. 6 was not broken at the highest load of the testing machine.

Columns Nos. 3 and 4 were taken from the Ireland Building, which collapsed on August 8, 1895; the other four 15-inch columns were made from drawings prepared by the Building Department, as nearly as possible duplicates of Nos. 3 and 4. Nos. 1 and 2 were made by a foundry in New York with no knowledge of their ultimate use. Nos. 5 and 6 were made



by a foundry in Brooklyn with the knowledge that they were to be tested. Nos. 7 to 10 were made from drawings furnished by the Department.

Applying Gordon's formula, as used by the Building Department,  $S = \frac{80000 a}{1 + \frac{1}{400} l^2}$ , to these columns gives for the breaking strength per square

inch of the 15-inch columns 57,143 pounds, for the 8-inch columns 40,000 pounds, and for the 6-inch columns 40,000. The strength of columns Nos. 3 and 4 as calculated is 128 per cent more than their actual strength; their actual strength is less than 44 per cent of their calculated strength; and the factor of safety, supposed to be 5 in the Building Law, is only 2.2 for central loading, no account being taken of the likelihood of eccentric loading.

Prof. Lanza, *Applied Mechanics*, p. 372, quotes the records of 14 tests of cast-iron mill columns, made on the Watertown testing-machine in 1887-88, the breaking strength per square inch ranging from 25,100 to 63,310 pounds, and showing no relation between the breaking strength per square inch and the dimensions of the columns. Only 3 of the 14 columns had a strength exceeding 33,500 pounds per square inch. The average strength of the other 11 was 29,600 pounds per square inch. Prof. Lanza says that it is evident that in the case of such columns we cannot rely upon a crushing strength of greater than 25,000 or 30,000 pounds per square inch of area of section.

He recommends a factor of safety of 5 or 6 with these figures for crushing strength, or 5000 pounds per square inch of area of section as the highest allowable safe load, and in addition makes the conditions that the length of the column shall not be greatly in excess of 20 times the diameter, that the thickness of the metal shall be such as to insure a good strong casting, and that the sectional area should be increased if necessary to insure that the extreme fibre stress due to probable eccentric loading shall not be greater than 5000 pounds per square inch.

Prof. W. H. Burr (*Eng'g News*, June 30, 1898) gives a formula derived from plotting the results of the Watertown and Phoenixville tests, above described, which represents the average strength of the columns in pounds per square inch. It is  $p = 30,500 - 160 l/d$ . It is to be noted that this is an average value, and that the actual strength of many of the columns was much lower. Prof. Burr says: "If cast-iron columns are designed with anything like a reasonable and real margin of safety, the amount of metal required dissipates any supposed economy over columns of mild steel."

**Square Columns.** — Square cast-iron columns should be abandoned. They are liable to have serious internal strains from difference in contraction on two adjacent sides. John F. Ward, *Eng. News*, Apr. 16, 1896.

### Safe Load, in Tons of 2000 Lbs., for Round Cast-iron Columns, with Turned Capitals and Bases.

Loads being not eccentric, and length of column not exceeding 20 times the diameter. Based on ultimate crushing strength of 25,000 lbs. per sq. in. and a factor of safety of 5.

Thick- ness, Inches.	Diameter, Inches.												
	6	7	8	9	10	11	12	13	14	15	16	18	
5/8	26.4	31.3											
3/4	30.9	36.8	42.7	48.6	54.5								
7/8	35.2	42.1	48.9	55.8	62.7	69.6	76.5						
1	39.2	47.1	55.0	62.8	70.7	78.5	86.4	94.2	102.1	110.0			
1 1/8	....	....	60.8	69.6	78.4	87.2	96.1	104.9	113.8	122.6	131.4		
1 1/4	....	....	....	76.1	85.9	95.7	105.5	115.3	125.2	135.0	144.8	164.4	
1 3/8	....	....	....	....	93.1	103.9	114.7	125.5	136.3	147.1	157.9	179.5	
1 1/2	....	....	....	....	....	....	123.7	135.5	147.3	159.0	170.8	194.4	
1 3/4	....	....	....	....	....	....	....	....	168.4	182.1	195.8	223.3	
2	....	....	....	....	....	....	....	....	....	204.2	219.9	251.3	

For lengths greater than 20 diameters the allowable loads should be decreased. How much they should be decreased is uncertain, since sufficient data of experiments on full-sized very long columns, from which a formula for the strength of such columns might be derived, are as yet lacking. There is, however, rarely, if ever, any need of proportioning cast-iron columns with a length exceeding 20 diameters.

### Safe Loads in Tons of 2000 Pounds for Cast-iron Columns.

(By the Building Laws of New York City, Boston, and Chicago, 1897.)

	New York.	Boston.	Chicago.
Square columns . . . .	$\left\{ \frac{8a}{1 + \frac{l^2}{500d^2}} \right.$	$\frac{5a}{1 + \frac{l^2}{1067d^2}}$	$\frac{5a}{1 + \frac{l^2}{800d^2}}$
Round columns . . . .	$\left\{ \frac{8a}{1 + \frac{l^2}{400d^2}} \right.$	$\frac{5a}{1 + \frac{l^2}{800d^2}}$	$\frac{5a}{1 + \frac{l^2}{600d^2}}$

$a$  = sectional area in square inches;  $l$  = unsupported length of column in inches;  $d$  = side of square column or thickness of round column in inches.

The safe load of a 15-inch round column  $1\frac{1}{2}$  inches in thickness, 16 feet long, according to the laws of these cities would be, in New York, 361 tons; in Boston, 264 tons; in Chicago, 250 tons.

The allowable stress per square inch of area of such a column would be, in New York, 11,350 pounds; in Boston, 8300 pounds; in Chicago, 7850 pounds. A safe stress of 5000 pounds per square inch would give for the safe load on the column 159 tons.

**Strength of Brackets on Cast-iron Columns.** — The columns tested by the New York Building Department referred to above had brackets cast upon them, each bracket, consisting of a rectangular shelf supported by one or two triangular ribs. These were tested after the columns had been broken in the principal tests. In 17 out of 22 cases the brackets broke by tearing a hole in the body of the column, instead of by shearing or transverse breaking of the bracket itself. The results were surprisingly low and very irregular. Reducing them to strength per square inch of the total vertical section through the shelf and rib or ribs, they ranged from 2450 to 5600 lbs., averaging 4200 lbs., for a load concentrated at the end of the shelf, and 4100 to 10,900 lbs., averaging 8000 lbs., for a distributed load. (*Eng'g News*, Jan. 20, 1898.)

**Maximum Permissible Stresses** in columns used in buildings. (Building Ordinances of City of Chicago, 1893.)

For riveted or other forms of wrought-iron columns:

$$S = \frac{12000a}{1 + \frac{l^2}{36000r^2}} \quad \begin{array}{l} l = \text{length of column in inches;} \\ r = \text{least radius of gyration in inches;} \\ a = \text{area of column in square inches.} \end{array}$$

For riveted or other steel columns, if more than  $60r$  in length:

$$S = 17,000 - \frac{60l}{r}$$

If less than  $60r$  in length:  $S = 13,500a$ .

For wooden posts:

$$S = \frac{ac}{1 + \frac{l^2}{250d^2}} \quad \begin{array}{l} a = \text{area of post in square inches;} \\ d = \text{least side of rectangular post in inches;} \\ l = \text{length of post in inches;} \\ c = \begin{cases} 600 \text{ for white or Norway pine;} \\ 800 \text{ for oak;} \\ 900 \text{ for long-leaf yellow pine.} \end{cases} \end{array}$$

**MOMENT OF INERTIA AND RADIUS OF GYRATION.**

The moment of inertia of a section is the sum of the products of each elementary area of the section into the square of its distance from an assumed axis of rotation, as the neutral axis.

Assume the section to be divided into a great many equal small areas,  $a$ , and that each such area has its own radius,  $r$ , or distance from the assumed axis of rotation, then the sum of all the products derived by multiplying each  $a$  by the square of its  $r$  is the moment of inertia,  $I$ , or  $I = \sum ar^2$ , in which  $\sum$  is the sign of summation.

For moment of inertia of the weight or mass of a body see Mechanics.

The radius of gyration of the section equals the square root of the quotient of the moment of inertia divided by the area of the section. If  $R$  = radius of gyration,  $I$  = moment of inertia and  $A$  = area

$$R = \sqrt{I/A}. \quad I/A = R^2.$$

The center of gyration is the point where the entire area might be concentrated and have the same moment of inertia as the actual area. The distance of this center from the axis of rotation is the radius of gyration.

The moments of inertia of various sections are as follows:

$d$  = diameter, or outside diameter;  $d_1$  = inside diameter;  $b$  = breadth;  $h$  = depth;  $b_1$ ,  $h_1$ , inside breadth and depth;

Solid rectangle  $I = 1/12bh^3$ ;      Hollow rectangle  $I = 1/12(bh^3 - b_1h_1^3)$ ;

Solid square  $I = 1/12b^4$ ;      Hollow square  $I = 1/12(b^4 - b_1^4)$ ;

Solid cylinder  $I = 1/64\pi d^4$ ;      Hollow cylinder  $I = 1/64\pi(d^4 - d_1^4)$ .

**Moment of Inertia about any Axis.** — If  $b$  = breadth and  $h$  = depth of a rectangular section its moment of inertia about its central axis (parallel to the breadth) is  $1/12 bh^3$ ; and about one side is  $1/3 bh^3$ . If a parallel axis exterior to the section is taken, and  $d$  = distance of this axis from the farthest side and  $d_1$  = its distance from the nearest side, ( $d - d_1 = h$ ), the moment of inertia about this axis is  $1/3 b (d^3 - d_1^3)$ .

The moment of inertia of a compound shape about any axis is equal to the sum of the moments of inertia, with reference to the same axis, of all the rectangular portions composing it.

**Moment of Inertia of Compound Shapes.** (Pencoyd Iron Works.) — The moment of inertia of any section about any axis is equal to the  $I$  about a parallel axis passing through its centre of gravity + (the area of the section  $\times$  the square of the distance between the axes).

By this rule, the moments of inertia or radii of gyration of any single sections being known, corresponding values may be obtained for any combination of these sections.

E. A. Dixon (*Am. Mach.*, Dec. 15, 1898) gives the following formula for the moment of inertia of any rectangular element of a built up beam:  $I = 1/3 (h^3 - h_1^3)b$ ,  $I$  = moment of inertia about any axis parallel to the neutral axis,  $h$  = distance from the assumed axis to the farthest fiber,  $h_1$  = distance to nearest fiber,  $b$  = breadth of element. The sum of the moments of inertia of all the elements, taken about the center of gravity or neutral axis of the section, is the moment of inertia of the section.

The polar moment of inertia of a surface is the sum of the products obtained by multiplying each elementary area by the square of its distance from the center of gravity of the surface; it is equal to the sum of the moments of inertia taken with respect to two axes at right angles to each other passing through the center of gravity. It is represented by  $J$ . For a solid shaft  $J = 1/32 \pi d^4$ ; for a hollow shaft,  $J = 1/32 \pi (d^4 - d_1^4)$ , in which  $d$  is the outside and  $d_1$  the inside diameter.

The polar radius of gyration,  $R_p = \sqrt{J/A}$ , is defined as the radius of a circumference along which the entire area might be concentrated and have the same polar moment of inertia as the actual area.

For a solid circular section  $R_p^2 = 1/8 D^2$ ; for a hollow circular section  $R_p^2 = 1/8 (d^2 + d_1^2)$ .

**Moments of Inertia and Radius of Gyration for Various Sections, and their Use in the Formulas for Strength of Girders and Columns.** — The strength of sections to resist strains, either as girders or as columns, depends not only on the area but also on the form of the section, and the property of the section which forms the



basis of the constants used in the formulas for strength of girders and columns to express the effect of the form, is its moment of inertia about its neutral axis. The modulus of resistance of any section to transverse bending is its moment of inertia divided by the distance from the neutral axis to the fibres farthest removed from that axis; or

$$\text{Section modulus} = \frac{\text{Moment of inertia}}{\text{Distance of extreme fibre from axis}} \cdot Z = \frac{I}{c}$$

Moment of resistance = section modulus  $\times$  unit stress on extreme fibre.

**Radius of Gyration of Compound Shapes.** — In the case of a pair of any shape without a web the value of  $R$  can always be found without considering the moment of inertia.

The radius of gyration for any section around an axis parallel to another axis passing through its centre of gravity is found as follows:

Let  $r$  = radius of gyration around axis through centre of gravity;  $R$  = radius of gyration around another axis parallel to above;  $d$  = distance between axes:  $R = \sqrt{d^2 + r^2}$ .

When  $r$  is small,  $R$  may be taken as equal to  $d$  without material error.

**Graphical Method for Finding Radius of Gyration.** — Benj. F. La Rue, *Eng. News*, Feb. 2, 1893, gives a short graphical method for finding the radius of gyration of hollow, cylindrical, and rectangular columns, as follows:

For cylindrical columns:

Lay off to a scale of 4 (or 40) a right-angled triangle, in which the base equals the outer diameter, and the altitude equals the inner diameter of the column, or *vice versa*. The hypotenuse, measured to a scale of unity (or 10), will be the radius of gyration sought.

This depends upon the formula

$$G = \sqrt{\text{Mom. of inertia} \div \text{Area}} = 1/4 \sqrt{D^2 + d^2}$$

in which  $A$  = area and  $D$  = diameter of outer circle,  $a$  = area and  $d$  = diameter of inner circle, and  $G$  = radius of gyration.  $\sqrt{D^2 + d^2}$  is the expression for the hypotenuse of a right-angled triangle, in which  $D$  and  $d$  are the base and altitude.

The sectional area of a hollow round column is  $0.7854(D^2 - d^2)$ . By constructing a right-angled triangle in which  $D$  equals the hypotenuse and  $d$  equals the altitude, the base will equal  $\sqrt{D^2 - d^2}$ . Calling the value of this expression for the base  $B$ , the area will equal  $0.7854B^2$ .

Value of  $G$  for square columns:

Lay off as before, but using a scale of 10, a right-angled triangle of which the base equals  $D$  or the side of the outer square, and the altitude equals  $d$ , the side of the inner square. With a scale of 3 measure the hypotenuse, which will be, approximately, the radius of gyration.

This process for square columns gives an excess of slightly more than 4%. By deducting 4% from the result, a close approximation will be obtained.

A very close result is also obtained by measuring the hypotenuse with the same scale by which the base and altitude were laid off, and multiplying by the decimal 0.29; more exactly, the decimal is 0.28867.

The formula is













$$G = \sqrt{\frac{\text{Mom. of inertia}}{\text{Area}}} = \frac{1}{\sqrt{12}} \sqrt{D^2 + d^2} = 0.28867 \sqrt{D^2 + d^2}$$

This may also be applied to any rectangular column by using the lesser diameters of an unsupported column, and the greater diameters if the column is supported in the direction of its least dimensions.

### ELEMENTS OF USUAL SECTIONS.

Moments refer to horizontal axis through centre of gravity. This table is intended for convenient application where extreme accuracy is not important. Some of the terms are only approximate; those marked \* are correct. Values for radius of gyration in flanged beams apply to standard minimum sections only.  $A$  = area of section;  $b$  = breadth;  $h$  = depth;  $D$  = diameter.



Shape of Section.	Moment of Inertia.	Section Modulus.	Square of Least Radius of Gyration.	Least Radius of Gyration.
 Solid Rect-angle.	$\frac{bh^3}{12}$	$\frac{bh^2}{6}$	$(\text{Least side})^2$ $\frac{\quad}{12}$	Least side * $\frac{\quad}{3.46}$
 Hollow Rect-angle.	$\frac{bh^3 - b_1h_1^3}{12}$	$\frac{bh^3 - b_1h_1^3}{6h}$	$\frac{h^2 + h_1^2}{12}$	$\frac{h + h_1}{4.89}$
 Solid Circle.	$\frac{1}{64} \pi D^4$ $= 0.0491 D^4$	$\frac{1}{32} \pi D^3$ $= 0.0982 D^3$	$\frac{D^2}{16}$	$\frac{D}{4}$
 Hollow Circle. A, area of large section; a, area of small section.	$\frac{AD^2 - ad^2}{16}$	$\frac{AD^2 - ad^2}{8D}$	$\frac{D^2 + d^2}{16}$	$\frac{D + d}{5.64}$
 Solid Triangle.	$\frac{bh^3}{36}$	$\frac{bh^2}{24}$	The least of the two; $\frac{h^2}{18}$ or $\frac{b^2}{24}$	The least of the two; $\frac{h}{4.24}$ or $\frac{b}{4.9}$
 Even Angle.	$\frac{Ah^2}{10.2}$	$\frac{Ah}{7.2}$	$\frac{b^2}{25}$	$\frac{b}{5}$
 Uneven Angle.	$\frac{Ah^2}{9.5}$	$\frac{Ah}{6.5}$	$\frac{(hb)^2}{13(h^2 + b^2)}$	$\frac{hb}{2.6(h + b)}$
 Even Cross.	$\frac{Ah^2}{19}$	$\frac{Ah}{9.5}$	$\frac{h^2}{22.5}$	$\frac{h}{4.74}$
 Even Tee.	$\frac{Ah^2}{11.1}$	$\frac{Ah}{8}$	$\frac{b^2}{22.5}$	$\frac{b}{4.74}$
 I Beam.	$\frac{Ah^2}{6.66}$	$\frac{Ah}{3.2}$	$\frac{b^2}{21}$	$\frac{b}{4.58}$
 Channel.	$\frac{Ah^2}{7.34}$	$\frac{Ah}{3.67}$	$\frac{b^2}{12.5}$	$\frac{b}{3.54}$
 Deck Beam.	$\frac{Ah^2}{6.9}$	$\frac{Ah}{4}$	$\frac{b^2}{36.5}$	$\frac{b}{6}$

Distance of base from centre of gravity, solid triangle,  $\frac{h}{3}$ ; even angle,  $\frac{h}{3.3}$ ; uneven angle,  $\frac{h}{3.5}$ ; even tee,  $\frac{h}{3.3}$ ; deck beam,  $\frac{h}{2.3}$ ; all other shapes given in the table,  $\frac{h}{2}$  or  $\frac{D}{2}$ .

### ECCENTRIC LOADING OF COLUMNS.

In a given rectangular cross-section, such as a masonry joint under pressure, the stress will be distributed uniformly over the section only when the resultant passes through the centre of the section; any deviation from such a central position will bring a maximum unit pressure to one edge and a minimum to the other; when the distance of the resultant from one edge is one third of the entire width of the joint, the pressure at the nearer edge is twice the mean pressure, while that at the farther edge is zero, and that when the resultant approaches still nearer to the edge the pressure at the farther edge becomes less than zero; in fact, becomes a tension, if the material (mortar, etc.) there is capable of resisting tension. Or, if, as usual in masonry joints, the material is practically incapable of resisting tension, the pressure at the nearer edge, when the resultant approaches it nearer than one third of the width, increases very rapidly and dangerously, becoming theoretically infinite when the resultant reaches the edge.

With a given position of the resultant relatively to one edge of the joint or section, a similar redistribution of the pressures throughout the section may be brought about by simply adding to or diminishing the width of the section.

Let  $P$  = the total pressure on any section of a bar of uniform thickness.

$w$  = the width of that section = area of the section, when thickness = 1.

$p = P/w$  = the mean unit pressure on the section.

$M$  = the maximum unit pressure on the section.

$m$  = the minimum unit pressure on the section.

$d$  = the eccentricity of the resultant = its distance from the centre of the section.

$$\text{Then } M = p \left( 1 + \frac{6d}{w} \right) \text{ and } m = p \left( 1 - \frac{6d}{w} \right).$$

$$\text{When } d = \frac{1}{6} w \text{ then } M = 2p \text{ and } m = 0.$$

When  $d$  is greater than  $1/6 w$ , the resultant in that case being less than one third of the width from one edge,  $p$  becomes negative. (J. C. Trautwine, Jr., *Engineering News*, Nov. 23, 1893.)

**Eccentric Loading of Cast-iron Columns.** — Prof. Lanza writes the author as follows: The table on page 276 applies when the resultant of the loads upon the column acts along its central axis, *i.e.*, passes through the centre of gravity of every section. In buildings and other constructions, however, cases frequently occur when the resultant load does not pass through the centre of gravity of the section; and then the pressure is not evenly distributed over the section, but is greatest on the side where the resultant acts. (Examples occur when the loads on the floors are not uniformly distributed.) In these cases the outside fibre stresses of the column should be computed as follows, *viz.*:

Let  $P$  = total pressure on the section;

$d$  = eccentricity of resultant = its distance from the centre of gravity of the section;

$A$  = area of the section, and  $I$  its moment of inertia about an axis in its plane, passing through its centre of gravity, and perpendicular to  $d$ ;

$c_1$  = distance of most compressed and  $c_2$  = that of least compressed fibre from above stated axis;

$s_1$  = maximum and  $s_2$  = minimum pressure per unit of area. Then

$$s_1 = \frac{P}{A} + \frac{(Pd)c_1}{I} \quad \text{and} \quad s_2 = \frac{P}{A} - \frac{(Pd)c_2}{I}.$$

Having assumed a certain *trial* section for the column to be designed,  $s_1$  should be computed, and, if it exceed the proper safe value, a different section should be used for which  $s_1$  does not exceed this value.

The proper safe value, in the case of cast-iron columns whose ratio of length to diameter does not greatly exceed 20, is 5000 pounds per square inch when the eccentricity used in the computation of  $s_1$  is liable to occur frequently in the ordinary uses of the structure; but when it is one which can only occur in rare cases the value 8000 lbs. per sq. in. may be used.

A long cap on a column is more conducive to the production of eccentricity of loading than a short one, hence a long cap is a source of weakness.

## TRANSVERSE STRENGTH.

In transverse tests the strength of bars of rectangular section is found to vary directly as the breadth of the specimen tested, as the square of its depth, and inversely as its length. The deflection under any load varies as the cube of the length, and inversely as the breadth and as the cube of the depth. Represented algebraically, if  $S$  = the strength and  $D$  the deflection,  $l$  the length,  $b$  the breadth, and  $d$  the depth,

$$S \text{ varies as } \frac{bd^2}{l} \text{ and } D \text{ varies as } \frac{l^3}{bd^3}.$$

For the purpose of reducing the strength of pieces of various sizes to a common standard, the term *modulus of rupture* (represented by  $R$ ) is used. Its value is obtained by experiment on a bar of rectangular section supported at the ends and loaded in the middle and substituting numerical values in the following formula:

$$R = \frac{3 Pl}{2 bd^2},$$

in which  $P$  = the breaking load in pounds,  $l$  = the length in inches,  $b$  the breadth, and  $d$  the depth.

The *modulus of rupture* is sometimes defined as the strain at the instant of rupture upon a unit of the section which is most remote from the neutral axis on the side which first ruptures. This definition, however, is based upon a theory which is yet in dispute among authorities, and it is better to define it as a numerical value, or experimental constant, found by the application of the formula above given.

From the above formula, making  $l$  12 inches, and  $b$  and  $d$  each 1 inch, it follows that the modulus of rupture is 18 times the load required to break a bar one inch square, supported at two points one foot apart, the load being applied in the middle.

$$\begin{aligned} \text{Coefficient of transverse strength} &= \frac{\text{span in feet} \times \text{load at middle in lbs.}}{\text{breadth in inches} \times (\text{depth in inches})^2} \\ &= \frac{1}{18} \text{th of the modulus of rupture.} \end{aligned}$$

**Fundamental Formulæ for Flexure of Beams (Merriman).**

Resisting shear = vertical shear;

Resisting moment = bending moment;

Sum of tensile stresses = sum of compressive stresses;

Resisting shear = algebraic sum of all the vertical components of the internal stresses at any section of the beam.

If  $A$  be the area of the section and  $S_s$  the shearing unit stress, then resisting shear =  $AS_s$ ; and if the vertical shear =  $V$ , then  $V = AS_s$ .

The *vertical shear* is the algebraic sum of all the external vertical forces on one side of the section considered. It is equal to the reaction of one support, considered as a force acting upward, minus the sum of all the vertical downward forces acting between the support and the section.

The *resisting moment* = algebraic sum of all the moments of the internal horizontal stresses at any section with reference to a point in that

section, =  $\frac{SI}{c}$ , in which  $S$  = the horizontal unit stress, tensile or compressive as the case may be, upon the fibre most remote from the neutral axis,  $c$  = the shortest distance from that fibre to said axis, and  $I$  = the moment of inertia of the cross-section with reference to that axis.

The *bending moment*  $M$  is the algebraic sum of the moment of the external forces on one side of the section with reference to a point in that section = moment of the reaction of one support minus sum of moments of loads between the support and the section considered.

$$M = \frac{SI}{c}.$$

The bending moment is a compound quantity = product of a force by the distance of its point of application from the section considered, the distance being measured on a line drawn from the section perpendicular to the direction of the action of the force.



Concerning the formula,  $M=SI/c$ , p. 297, Prof. Merriman, *Eng. News*, July 21, 1894, says: The formula quoted is true when the unit-stress  $S$  on the part of the beam farthest from the neutral axis is within the elastic limit of the material. It is not true when this limit is exceeded, because then the neutral axis does not pass through the center of gravity of the cross-section, and because also the different longitudinal stresses are not proportional to their distances from that axis, these two requirements being involved in the deduction of the formula. But in all cases of design the permissible unit-stresses should not exceed the elastic limit, and hence the formula applies rationally, without regarding the ultimate strength of the material or any of the circumstances regarding rupture. Indeed, so great reliance is placed upon this formula that the practice of testing beams by rupture has been almost entirely abandoned, and the allowable unit-stresses are mainly derived from tensile and compressive tests.

### APPROXIMATE GREATEST SAFE LOADS IN LBS. ON STEEL BEAMS. (Pencoyd Iron Works.)

Based on fiber strains of 16,000 lbs. for steel. (For iron the loads should be one-eighth less, corresponding to a fibre strain of 14,000 lbs. per square inch.) Beams supported at the ends and uniformly loaded.

$L$  = length in feet between supports;  $a$  = interior area in square inches;  
 $A$  = sectional area of beam in square inches;  $d$  = interior depth in inches.  
 $D$  = depth of beam in inches.  $w$  = working load in net tons.

Shape of Section.	Greatest Safe Load in Pounds.		Deflection in Inches.	
	Load in Middle.	Load Distributed.	Load in Middle.	Load Distributed.
Solid Rectangle.	$\frac{890AD}{L}$	$\frac{1780AD}{L}$	$\frac{wL^3}{32AD^2}$	$\frac{wL^3}{52AD^2}$
Hollow Rectangle.	$\frac{890(AD-ad)}{L}$	$\frac{1780(AD-ad)}{L}$	$\frac{wL^3}{32(AD^2-ad^2)}$	$\frac{wL^3}{52(AD^2-ad^2)}$
Solid Cylinder.	$\frac{667AD}{L}$	$\frac{1333AD}{L}$	$\frac{wL^3}{24AD^2}$	$\frac{wL^3}{38AD^2}$
Hollow Cylinder.	$\frac{667(AD-ad)}{L}$	$\frac{1333(AD-ad)}{L}$	$\frac{wL^3}{24(AD^2-ad^2)}$	$\frac{wL^3}{38(AD^2-ad^2)}$
Even-legged Angle or Tee.	$\frac{885AD}{L}$	$\frac{1770AD}{L}$	$\frac{wL^3}{32AD^2}$	$\frac{wL^3}{52AD^2}$
Channel or Z bar	$\frac{1525AD}{L}$	$\frac{3050AD}{L}$	$\frac{wL^3}{53AD^2}$	$\frac{wL^3}{85AD^2}$
Deck Beam.	$\frac{1380AD}{L}$	$\frac{2760AD}{L}$	$\frac{wL^3}{50AD^2}$	$\frac{wL^3}{80AD^2}$
I Beam.	$\frac{1695AD}{L}$	$\frac{3390AD}{L}$	$\frac{wL^3}{58AD^2}$	$\frac{wL^3}{93AD^2}$
I	II	III	IV	V

The above formulæ for the strength and stiffness of rolled beams of various sections are intended for convenient application in cases where strict accuracy is not required.



GENERAL FORMULÆ FOR TRANSVERSE STRENGTH OF BEAMS OF UNIFORM CROSS-SECTION.

Beam. (For notation see page 300.)	Rectangular Beam.		Beam of any Section.		
	Breaking Load.	Deflection for Load $P$ or $W$ .	Maximum Moment of Stress.	Moment of Rupture.	Deflection. $\Delta$
Fixed at one end, load at the other . . . . .	$P = \frac{1}{6} \frac{Rbd^2}{l}$	$\frac{4Pl^3}{Ebd^3}$	$Pl$	$\frac{RI}{c}$	$\frac{1}{3} \frac{Pl^3}{EI}$
Same with load distributed uniformly . . . . .	$W = \frac{1}{3} \frac{Rbd^2}{l}$	$\frac{3}{2} \frac{Wl^3}{Ebd^3}$	$\frac{1}{2} Wl$	$\frac{RI}{c}$	$\frac{1}{8} \frac{Wl^3}{EI}$
Supported at ends, loaded in middle . . . . .	$P = \frac{2}{3} \frac{Rbd^2}{l}$	$\frac{Pl^3}{4Ebd^3}$	$\frac{1}{4} Pl$	$\frac{RI}{c}$	$\frac{1}{48} \frac{Pl^3}{EI}$
Same, loaded uniformly . . . . .	$W = \frac{4}{3} \frac{Rbd^2}{l}$	$\frac{5}{32} \frac{Wl^3}{Ebd^3}$	$\frac{1}{8} Wl$	$\frac{RI}{c}$	$\frac{5}{384} \frac{Wl^3}{EI}$
Same, loaded at middle, and also with uniform load, . . . . .	$2P + W = \frac{4}{3} \frac{Rbd^2}{l}$	$\frac{1}{4} \left( P + \frac{1}{8} W \right) \frac{l^3}{Ebd^3}$	$\left( \frac{1}{4} P + \frac{1}{8} W \right) l$	$\frac{RI}{c}$	$\frac{1}{48} \left( P + \frac{5}{8} W \right) \frac{l^3}{EI}$
Fixed at both ends, loaded in middle . . . . .	$P = \frac{4}{3} \frac{Rbd^2}{l}$	$\frac{1}{16} \frac{Pl^3}{Ebd^3}$	$\frac{1}{8} Pl$	$\frac{RI}{c}$	$\frac{Pl^3}{192 EI}$
Same, Barlow's Experiments . . . . .	$P = \frac{Rbd^2}{l}$		$\frac{1}{6} Pl$	$\frac{RI}{c}$	
Same, uniformly loaded . . . . .	$W = \frac{2Rbd^2}{l}$	$\frac{1}{32} \frac{Wl^3}{Ebd^3}$	$\frac{1}{12} Wl$	$\frac{RI}{c}$	$\frac{W}{384} \frac{l^3}{EI}$
Fixed at one end, supported at the other, } loaded at 0.634 <i>l</i> from fixed end, }		$\frac{0.1148Pl^3}{Ebd^3}$	$\frac{3}{8} (2\sqrt{3} - 3) Pl$	$\frac{RI}{c}$	$\frac{Pl^3}{105 EI}$ (nearly)
Same, uniformly loaded . . . . .	$W = \frac{4}{3} \frac{Rbd^2}{l}$	$\frac{0.0648Wl^3}{Ebd^3}$	$\frac{1}{8} Wl$	$\frac{RI}{c}$	$\frac{W}{185} \frac{l^3}{EI}$ (nearly)

The rules for rectangular and circular sections are correct, while those for the flanged sections are approximate, and limited in their application to the standard shapes as given in the Pencoyd tables. When the section of any beam is increased above the standard minimum dimensions, the flanges remaining unaltered, and the web alone being thickened, the tendency will be for the load as found by the rules to be in excess of the actual; but within the limits that it is possible to vary any section in the rolling, the rules will apply without any serious inaccuracy.

The calculated safe loads will be approximately one half of loads that would injure the elasticity of the materials.

The rules for deflection apply to any load below the elastic limit, or less than double the greatest safe load by the rules.

If the beams are long without lateral support, reduce the loads for the ratios of width to span as follows:

Length of Beam.				Proportion of Calculated Load forming Greatest Safe Load.		
20 times flange width.				Whole calculated load.		
30	"	"	"	9-10	"	"
40	"	"	"	8-10	"	"
50	"	"	"	7-10	"	"
60	"	"	"	6-10	"	"
70	"	"	"	5-10	"	"

These rules apply to beams supported at each end. For beams supported otherwise, alter the coefficients of the table as described below, referring to the respective columns indicated by number.

#### Changes of Coefficients for Special Forms of Beams.

Kind of Beam.	Coefficient for Safe Load.	Coefficient for Deflection.
Fixed at one end, loaded at the other.	One fourth of the coefficient, col. II.	One sixteenth of the coefficient of col. IV.
Fixed at one end, load evenly distributed.	One fourth of the coefficient of col. III.	Five forty-eighths of the coefficient of col. V.
Both ends rigidly fixed, or a continuous beam, with a load in middle.	Twice the coefficient of col. II.	Four times the coefficient of col. IV.
Both ends rigidly fixed, or a continuous beam, with load evenly distributed.	One and one-half times the coefficient of col. III.	Five times the coefficient of col. V.

**Formulae for Transverse Strength of Beams.** — Referring to table on page 299,

$P$  = load at middle;

$W$  = total load, distributed uniformly;

$l$  = length,  $b$  = breadth,  $d$  = depth, in inches;

$E$  = modulus of elasticity;

$R$  = modulus of rupture, or stress per square inch of extreme fiber;

$I$  = moment of inertia;

$c$  = distance between neutral axis and extreme fibre.

For breaking load of circular section, replace  $bd^2$  by  $0.59d^3$ .

The value of  $R$  at rupture, or the modulus of rupture (see page 282), is about 60,000 for structural steel, and about 110,000 for strong steel. (Merriman.)

For cast iron the value of  $R$  varies greatly according to quality. Thurston found 45,740 and 67,980 in No. 2 and No. 4 cast iron, respectively.

For beams fixed at both ends and loaded in the middle, Barlow, by experiment, found the maximum moment of stress =  $1/6 Pl$  instead of  $1/8 Pl$ , the result given by theory. Prof. Wood (Resist. Matls. p. 155) says of this case: The phenomena are of too complex a character to admit of a thorough and exact analysis, and it is probably safer to accept the results of Mr. Barlow in practice than to depend upon theoretical results.

### BEAMS OF UNIFORM STRENGTH THROUGHOUT THEIR LENGTH.

The section is supposed in all cases to be rectangular throughout. The beams shown in plan are of uniform depth throughout. Those shown in elevation are of uniform breadth throughout.

$B$  = breadth of beam.  $D$  = depth of beam.

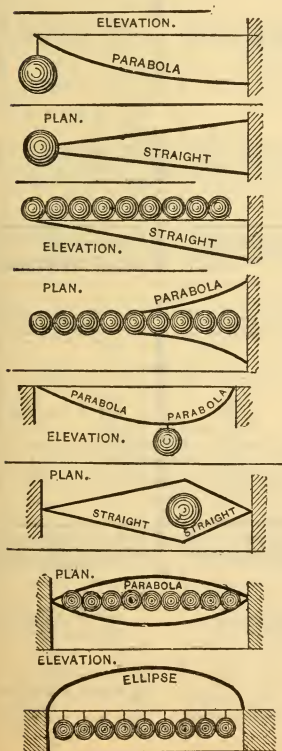

Fixed at one end, loaded at the other; curve parabola, vertex at loaded end;  $BD$  proportional to distance from loaded end. The beam may be reversed, so that the upper edge is parabolic, or both edges may be parabolic.

Fixed at one end, loaded at the other; triangle, apex at loaded end;  $BD^2$  proportional to the distance from the loaded end.

Fixed at one end; load distributed; triangle, apex at unsupported end;  $BD^2$  proportional to square of distance from unsupported end.

Fixed at one end; load distributed; curves two parabolas, vertices touching each other at unsupported end;  $BD^2$  proportional to distance from unsupported end.

Supported at both ends; load at any one point; two parabolas, vertices at the points of support, bases at point loaded;  $BD^2$  proportional to distance from nearest point of support. The upper edge or both edges may also be parabolic.

Supported at both ends; load at any one point; two triangles, apices at points of support, bases at point loaded;  $BD^2$  proportional to distance from the nearest point of support.

Supported at both ends; load distributed; curves two parabolas, vertices at the middle of the beam; bases centre line of beam;  $BD^2$  proportional to product of distances from points of support.

Supported at both ends; load distributed; curve semi-ellipse;  $BD^2$  proportional to the product of the distances from the points of support.

**DIMENSIONS AND WEIGHTS OF STRUCTURAL STEEL SECTIONS COMMONLY ROLLED.**

(Carnegie Steel Co., 1913.)

**Weights and Dimensions of Equal Angles. (Angles marked \* are special.)**

Size, In.	Thick-ness, In.	Wt. per Ft., Lb.	Size, In.	Thick-ness, In.	Wt. per Ft., Lb.	Size, In.	Thick-ness, In.	Wt. per Ft., Lb.
8 X 8	1 1/8	56.9	3 1/2 X 3 1/2	5/8	13.6	2 X 2	5/16	3.92
"	1 1/16	54.0	"	9/16	12.4	"	1/4	3.19
"	"	51.0	"	1/2	11.1	"	3/16	2.44
"	15/16	48.1	"	7/16	9.8	"	1/8	1.65
"	7/8	45.0	"	3/8	8.5	1 3/4 X 1 3/4*	7/16	4.6
"	13/16	42.0	"	5/16	7.2	"	3/8	3.99
"	3/4	38.9	"	1/4	5.8	"	5/16	3.39
"	11/16	35.8	3 X 3*	5/8	11.5	"	1/4	2.77
"	5/8	32.7	"	9/16	10.4	"	3/16	2.12
"	9/16	29.6	"	1/2	9.4	"	1/8	1.44
"	1/2	26.4	"	3/8	8.3	1 1/2 X 1 1/2*	3/8	3.35
6 X 6	1	37.4	"	5/16	7.2	"	5/16	2.86
"	15/16	35.3	"	1/4	6.1	"	1/4	2.34
"	7/8	33.1	"	3/8	4.9	"	3/16	1.80
"	13/16	31.0	"	1/2	7.7	"	1/8	1.23
"	3/4	28.7	2 1/2 X 2 1/2*	7/16	6.8	1 1/4 X 1 1/4*	5/16	2.33
"	11/16	26.5	"	3/8	5.9	"	1/4	1.92
"	5/8	24.2	"	5/16	5.0	"	3/16	1.48
"	9/10	21.9	"	1/4	4.1	"	1/8	1.01
"	1/2	19.6	"	3/16	3.07	1 X 1*	1/4	1.49
"	7/16	17.2	"	1/8	2.08	"	3/16	1.16
"	3/8	14.9	2 X 2*	7/16	5.3	"	1/8	0.80
5 X 5*	1	30.6	"	3/8	4.7	"	"	"

**Weights and Dimensions of Unequal Angles. (Angles marked \* are special.)**

8 X 6*	1	44.2	8 X 3 1/2*	1/2	18.7	7 X 3 1/2*	9/16	19.1
"	15/16	41.7	"	7/16	16.5	"	1/2	17.0
"	7/8	39.1	"	1	32.3	"	7/16	15.0
"	13/16	36.5	7 X 3 1/2*	15/16	30.5	"	3/8	13.0
"	3/4	33.8	"	7/8	28.7	6 X 4*	1	30.6
"	11/16	31.2	"	13/16	26.8	"	15/16	28.9
"	5/8	28.5	"	3/4	24.9	"	7/8	27.2
"	9/16	25.7	"	11/16	23.0	"	13/16	25.4
"	1/2	23.0	"	5/8	21.0	"	3/4	23.6



Weights and Dimensions of Unequal Angles. (Angles marked \* are special.)—Continued.

Size, In.	Thick- ness, In.	Wt. per Ft., Lb.	Size, In.	Thick- ness, In.	Wt. per Ft., Lb.	Size, In.	Thick- ness, In.	Wt. per Ft., Lb.	Size, In.	Thick- ness, In.	Wt. per Ft., Lb.
6×4	11/16	21.8	5×3 1/2	1/2	13.6	4×3*	11/16	14.8	3×2*	7/16	6.8
"	5/8	20.0	"	7/16	10.4	"	5/8	13.6	"	3/8	5.9
"	9/16	18.1	"	3/8	10.4	"	9/16	12.4	"	5/16	5.0
"	1 1/2	16.2	"	5/16	8.7	"	1/2	11.1	"	1/4	4.1
"	7/16	14.3	5×3*	13/16	19.9	"	7/16	9.8	2 1/2×2*	1/2	6.8
"	3/8	12.3	"	3/4	18.5	"	3/8	8.5	"	7/16	6.1
6×3 1/2*	1	28.9	"	11/16	17.1	"	5/16	7.2	"	3/8	5.3
"	15/16	27.3	"	5/8	15.7	"	1/4	5.8	"	5/16	4.5
"	7/8	25.7	"	9/16	14.3	3 1/2×3*	13/16	15.8	"	1/4	3.62
6×3 1/2	13/16	24.0	"	1/2	12.8	"	3/4	14.7	"	3/16	2.75
"	3/4	22.4	"	7/16	11.3	"	11/16	13.6	"	1/8	1.86
"	11/16	20.6	"	3/8	9.8	"	5/8	12.5	2 1/2×1 1/2*	5/16	3.92
"	5/8	18.9	"	5/16	8.2	"	9/16	11.4	"	1/4	3.19
"	9/16	17.1	4 1/2×3*	13/16	18.5	"	1/2	10.2	"	3/16	2.44
"	1 1/2	15.3	"	3/4	17.3	"	7/16	9.1	2 1/4×1 1/2*	1/2	5.6
"	7/16	13.5	"	11/16	16.0	"	3/8	7.9	"	7/16	5.0
"	3/8	11.7	"	5/8	14.7	"	5/16	6.6	"	5/8	4.4
"	5/16	9.8	"	9/16	13.3	"	1/4	5.4	"	5/16	3.66
5×4*	7/8	24.2	"	1/2	11.9	3 1/2×2 1/2**	11/16	12.5	"	1/4	2.98
"	13/16	22.7	"	7/16	10.6	"	5/8	11.5	"	3/16	2.28
"	3/4	21.1	"	3/8	9.1	"	9/16	10.4	2×1 1/2**	3/8	3.99
"	11/16	19.5	"	5/16	7.7	"	1/2	9.4	"	5/16	3.39
"	5/8	17.8	4×3 1/2**	13/16	18.5	"	7/16	8.3	"	1/4	2.77
"	9/16	16.2	"	3/4	17.3	"	3/8	7.2	"	3/16	2.12
"	1 1/2	14.5	"	11/16	16.0	"	5/16	6.1	"	1/8	1.44
"	7/16	12.8	"	5/8	14.7	"	1/4	4.9	2×1 1/4*	1/4	2.55
"	3/8	11.0	"	9/16	13.3	3×2 1/2**	9/16	9.5	"	3/16	1.96
5×3 1/2**	7/8	22.7	"	1/2	11.9	"	1/2	8.5	1 3/4×1 1/4*	1/4	2.34
"	13/16	21.3	"	7/16	10.6	"	3/8	7.6	"	3/16	1.80
"	3/4	19.8	"	3/8	9.1	"	5/16	6.6	"	1/8	1.23
"	11/16	18.3	"	5/16	7.7	"	1/4	5.6	1 1/2×1 1/4**	5/16	2.59
"	5/8	16.8	4×3*	13/16	17.1	"	1/4	4.5	"	1/4	2.13
"	9/16	15.2	"	3/4	16.0	3×2*	1/2	7.7	"	3/16	1.64

Weights and Dimensions of Unequal Tees. (Size Given is Flange X Stem.)

Size, In.	Thick-ness, In.	Wt. per Ft., Lb.	Size, In.	Thick-ness, In.	Wt. per Ft., Lb.	Size, In.	Thick-ness, In.	Wt. per Ft., Lb.	Size, In.	Thick-ness, In.	Wt. per Ft., Lb.
5 X 3	1/2 X 13/32	13.4	4 X 4 1/2	3/8 X 3/8	11.2	3 1/2 X 3	3/8 X 3/8	8.5	3 X 2 1/2	1/4 X 1/4	5.0
5 X 2 1/2	3/8 X 7/16	10.9	4 X 3	3/8 X 3/8	9.2	3 X 4	5/16 X 3/8	7.5	2 1/2 X 3	3/8 X 3/8	7.1
4 1/2 X 3 1/2	7/16 X 11/16	15.7	4 X 2 1/2	5/16 X 5/16	7.8	3 X 4	1/2 X 1/2	11.7	2 1/2 X 1 1/4	5/16 X 5/16	6.1
4 1/2 X 3	3/8 X 3/8	9.8	4 X 2	3/8 X 3/8	8.5	3 X 4	3/8 X 3/8	10.5	2 X 1 1/2	3/16 X 3/16	2.87
4 1/2 X 2 1/2	5/16 X 5/16	8.4	4 X 2	5/16 X 5/16	7.2	3 X 3 1/2	3/8 X 3/8	9.2	2 X 1 1/2	1/4 X 1/4	3.09
4 X 5	3/8 X 3/8	9.2	3 1/2 X 4	3/8 X 3/8	7.8	3 X 2 1/2	1/2 X 1/2	10.8	1 1/2 X 1 1/4	3/16 X 3/16	2.45
4 X 4 1/2	5/16 X 5/16	7.8	3 1/2 X 3	5/16 X 5/16	6.7	3 X 2 1/2	1/2 X 1/2	9.7	1 1/2 X 1 1/4	1/8 X 1/8	1.25
	1/2 X 1 1/2	15.3		1/2 X 1/2	12.6		3/8 X 3/8	8.5		No. 9 X 1/8	0.88
	3/8 X 3/8	11.9		3/8 X 3/8	9.8		5/16 X 5/16	7.1			
	1/2 X 1 1/2	14.4		1/2 X 1/2	10.8			6.1			

Weights and Dimensions of Equal Tees.

Size, In.	Thick-ness, In.	Wt. per Ft., Lb.	Size, In.	Thick-ness, In.	Wt. per Ft., Lb.	Size, In.	Thick-ness, In.	Wt. per Ft., Lb.
4 X 4	1/2	13.5	2 X 2	5/16	4.3	1 1/4 X 1 1/4	3/16	1.59
3 1/2 X 3 1/2	3/8	10.5	1 3/4 X 1 3/4	1/4	3.56	1 X 1	3/16	1.25
3 X 3	1/2	11.7	1 1/2 X 1 1/2	1/4	3.09		1/8	0.89
	3/8	9.2	2 1/4 X 2 1/4	5/16	2.47			
	1/2	9.9		3/16	1.94			
	7/16	8.9		1/4	2.02			

Weights and Dimensions of Z-Bars. (Size Given is Flanges X Web.)

Size, In.	Thick-ness, In.	Wt. per Ft., Lb.	Size, In.	Thick-ness, In.	Wt. per Ft., Lb.	Size, In.	Thick-ness, In.	Wt. per Ft., Lb.
3 5/8 X 6 1/8	7/8	34.6	3 3/16 X 4 1/8	3/4	23.0	2 3/4 X 3 1/16	9/16	14.3
3 9/16 X 6 1/16	11/16	28.1	3 1/8 X 4 1/16	9/16	18.0		7/16	11.5
3 1/2 X 6	1/2	21.1	3 1/16 X 4	3/8	12.5		5/16	8.5
	13/16	32.0	3 1/8 X 4 1/16	11/16	20.9		1/2	12.6
	5/8	25.4	3 1/16 X 4	1/2	15.9		3/8	9.8
	7/16	18.4	3 1/16 X 4	5/16	10.3		1/4	6.7
	3/4	29.4		7/16	13.8			
	9/16	22.8		1/4	8.2			
	3/8	15.7						

Weights and Dimensions of I-Beams.

Size, In.	Wt. per Ft., Lb.	Size, In.	Wt. per Ft., Lb.	Size, In.	Wt. per Ft., Lb.	Size, In.	Wt. per Ft., Lb.	Size, In.	Wt. per Ft., Lb.	Size, In.	Wt. per Ft., Lb.
27	83.0	20	90.0	18	55.0	12	45.0	9	21.0	5	12.25
24	115.0	"	85.0	"	46.0	"	40.0	8	25.5	"	9.75
"	110.0	"	80.0	15	75.0	"	35.0	"	23.0	4	10.5
"	105.0	"	75.0	"	70.0	"	31.5	"	20.5	"	9.5
"	100.0	"	70.0	"	65.0	"	27.5	"	18.0	"	8.5
"	95.0	"	65.0	"	60.0	10	40.0	"	17.5	"	7.5
"	90.0	18	90.0	"	55.0	"	35.0	7	20.0	3	7.5
"	85.0	"	85.0	"	50.0	"	30.0	"	17.5	"	6.5
"	80.0	"	80.0	"	45.0	"	25.0	"	15.0	"	5.5
"	69.5	"	75.0	"	42.0	"	22.0	6	17.25	.....	.....
21	57.5	"	70.0	"	36.0	9	35.0	"	14.75	.....	.....
20	100.0	"	65.0	12	55.0	"	30.0	"	12.25	.....	.....
"	95.0	"	60.0	"	50.0	"	25.0	5	14.75	.....	.....

Weights and Dimensions of Channels.

15	55.0	13	37.0	10	30.0	8	18.75	6	15.5	4	5.25
"	50.0	"	35.0	"	25.0	"	16.25	"	13.0	3	6.0
"	45.0	"	32.0	"	20.0	"	13.75	"	10.5	"	5.0
"	40.0	12	40.0	"	15.0	"	11.25	"	8.0	"	4.0
"	35.0	"	35.0	9	25.0	7	19.75	5	11.5	.....	.....
"	33.0	"	30.0	"	20.0	"	17.25	"	9.0	.....	.....
13	50.0	"	25.0	"	15.0	"	14.75	"	6.5	.....	.....
"	45.0	"	20.5	"	13.25	"	12.25	4	7.25	.....	.....
"	40.0	10	35.0	8	21.25	"	9.75	"	6.25	.....	.....

PROPERTIES OF ROLLED STRUCTURAL STEEL.

Explanation of Tables of the Properties of I-Beams, Channels, Angles, Z-Bars, Tees, etc. (Carnegie Steel Co.)

The tables of properties of I-beams and channels, pp. 307 to 313, are calculated for all standard sizes and weights to which each pattern is rolled, excepting for five weights of the 13-in. channel which is omitted in the tables. The table of properties of angles are calculated for the maximum, intermediate, and minimum weights of each size, excepting that only maximum and minimum weights are given for a few of the smaller sizes as noted in the tables. The properties of Z-bars are given for thicknesses differing by 1/16 in. The table of properties of Tee shapes lists the lightest section of each size. In the case of angles there will be two section moduli for each position of the neutral axis, since the distance between the neutral axis and the extreme fiber is different on either side of the axis. With T-sections there are two section moduli where the neutral axis is parallel to the flange. In these cases only the smaller section moduli are given.

The column headed *x*, in the table of the properties of standard channels, giving the distance of the center of gravity of channel from the outside of web, is used to obtain the radius of gyration for columns or struts consisting of two channels latticed, for the case of the neutral axis passing through the center of the cross-section parallel to the webs of the channels. This radius of gyration is equal to the distance between the center of gravity of the channel and the center of the section, i.e., neglecting the moments of inertia of the channels around their own axes, thereby introducing a slight error on the side of safety.

In the tables of safe loads of beams and channels, the safe loads for various lengths of span are given only for the lightest weight of each section rolled in the various sizes. The safe loads of the heavier weights of each section can be calculated from the data given in the tables of properties. The safe loads given in the tables are for a uniform load per running foot on the beam or channel. If the load, instead of being uniform, is concentrated at the center of the span, multiply it by 2 and then consider it as a uniform load. The deflection will be 0.8 X

the deflection for the uniform load. The safe loads in the tables are calculated solely with reference to the safe unit stresses due to flexure, and the values given will not produce average shearing stresses in the web greater than 10,000 lb. per sq. in., the maximum allowed in the American Bridge Co.'s specifications. When the beams carry concentrated loads, the buckling or shearing stresses in the web, rather than the resistance of the flanges to bending stresses may limit the carrying capacity.

The tables of safe loads for angles, tees, and Z-bars give the safe loads on a span of 1 ft., from which the safe load for any length of span may be obtained by direct division. They also give the values at which the allowed safe load will produce the maximum allowable deflection of 1/360 of the span length.

The tables are based on an extreme fiber stress of 16,000 lb. per sq. in., which is the customary figure for quiescent loads, as in buildings. Where running loads are involved, as in bridges, crane runways, etc., an extreme fiber stress of 12,500 lb. per sq. in. should be used and the values reduced accordingly. For suddenly applied loads, the extreme fiber stresses should be reduced to 8,000 lb. per sq. in.

It is assumed in the tables that the load is applied normal to the neutral axis perpendicular to the web at the center, and that the beam deflects only vertically in the plane of bending. For other conditions of loading, the safe load must be determined by the general theory of flexure (see page 297) in accordance with the mode of application of the load and its character. Under these conditions the safe loads will be considerably lower than those given in the tables. It is also assumed in the tables that the compression flanges of the various sections are secured against lateral deflection by the use of the rods at proper intervals. The lateral unsupported length of beams and girders should not exceed forty times the width of the compression flange. When the unsupported length exceeds ten times this width, the tabular safe loads should be reduced as follows, *W* being the width of the compression flange:

Length of unsupported flange.....	5W	10W	15W	20W	25W	30W	35W	40W
Percentage of full safe load allowed.....	100	100	90.6	81.2	71.9	62.5	53.1	43.8

In addition to the lateral deflection induced by pure bending stresses in the beam, there may be deflection due to the thrust of arches or other loads acting on a line perpendicular to the line of the principal stresses. These should be neutralized by tie rods so that in no case will the unit stresses exceed 16,000 lb. per sq. in.

(For much other important information concerning rolled structural shapes, see the "Pocket Companion" of the Carnegie Steel Co., Pittsburgh, Pa., price \$2.)

**Allowable Tension Values in Bars—Thousands of Pounds.**

(Carnegie Steel Co., 1913.)

Size, In.	Round Bars.		Square Bars.		Size, In.	Round Bars.		Square Bars.	
	Unit Stress 16,000 Lb. per Sq. In.	Unit Stress 20,000 Lb. per Sq. In.	Unit Stress 16,000 Lb. per Sq. In.	Unit Stress 20,000 Lb. per Sq. In.		Unit Stress 16,000 Lb. per Sq. In.	Unit Stress 20,000 Lb. per Sq. In.	Unit Stress 16,000 Lb. per Sq. In.	Unit Stress 20,000 Lb. per Sq. In.
1/4	0.8	1.0	1.0	1.3	13/4	38.5	48.1	49.0	61.3
1/2	3.1	3.9	4.0	5.0	2	50.3	62.8	64.0	80.0
3/4	7.1	8.8	9.0	11.3	2 1/4	63.6	79.5	81.0	101.3
1	12.6	15.7	16.0	20.0	2 1/2	78.5	98.2	100.0	125.0
1 1/4	19.6	24.5	25.0	31.3	2 3/4	95.0	118.8	121.0	151.3
1 1/2	28.3	35.3	36.0	45.0	3	113.1	141.4	144.0	180.0



Properties of Carnegie Standard I-Beams — Steel.\*

Depth of Beam.	Weight per Foot.	Area of Section.	Width of Flange.	Thickness of Web.	Neutral Axis Coincident with Center Line of Web.			Neutral Axis Perpendicular to Web at Center.		
					Moment of Inertia.	Radius of Gyration.	Section Modulus.	Moment of Inertia.	Radius of Gyration.	Section Modulus.
in.	lb.	sq. in.	in.	in.	in. <sup>4</sup>	in.	in. <sup>3</sup>	in. <sup>4</sup>	in.	in. <sup>3</sup>
27	83.0	24.41	7.500	0.424	2888.6	10.88	214.0	53.1	1.47	14.1
24	115.0	33.98	8.000	0.750	2955.5	9.33	246.3	83.2	1.57	20.8
"	110.0	32.48	7.938	0.688	2883.5	9.42	240.3	81.0	1.58	20.4
"	105.0	30.98	7.875	0.625	2811.5	9.53	234.3	78.9	1.60	20.0
"	100.0	29.41	7.254	0.754	2379.6	9.00	198.3	48.6	1.28	13.4
"	95.0	27.94	7.193	0.693	2309.0	9.09	192.4	47.1	1.30	13.1
"	90.0	26.47	7.131	0.631	2238.4	9.20	186.5	45.7	1.31	12.8
"	85.0	25.00	7.070	0.570	2167.8	9.31	180.7	44.4	1.33	12.6
"	80.0	23.32	7.000	0.500	2087.2	9.46	173.9	42.9	1.36	12.3
"	69.5	20.44	7.000	0.390	1928.0	9.71	160.7	39.3	1.39	11.2
21	57.5	16.85	6.500	0.357	1227.5	8.54	116.9	28.4	1.30	8.8
20	100.0	29.41	7.284	0.884	1655.6	7.50	165.6	52.7	1.34	14.5
"	95.0	27.94	7.210	0.810	1606.6	7.58	160.7	50.8	1.35	14.1
"	90.0	26.47	7.137	0.737	1557.6	7.67	155.8	49.0	1.36	13.7
"	85.0	25.00	7.063	0.663	1508.5	7.77	150.9	47.3	1.37	13.4
"	80.0	23.73	7.000	0.600	1466.3	7.86	146.6	45.8	1.39	13.1
"	75.0	22.06	6.399	0.649	1268.8	7.58	126.9	30.3	1.17	9.5
"	70.0	20.59	6.325	0.575	1219.8	7.70	122.0	29.0	1.19	9.2
"	65.0	19.08	6.250	0.500	1169.5	7.83	117.0	27.9	1.21	8.9
18	90.0	26.47	7.245	0.807	1260.4	6.90	140.0	52.0	1.40	14.4
"	85.0	25.00	7.163	0.725	1220.7	6.99	135.6	50.0	1.42	14.0
"	80.0	23.53	7.082	0.644	1181.0	7.09	131.2	48.1	1.43	13.6
"	75.0	22.05	7.000	0.562	1141.3	7.19	126.8	46.2	1.45	13.2
"	70.0	20.59	6.259	0.719	921.2	6.69	102.4	24.6	1.09	7.9
"	65.0	19.12	6.177	0.637	881.5	6.79	97.9	23.5	1.11	7.6
"	60.0	17.65	6.095	0.555	841.8	6.91	93.5	22.4	1.13	7.3
"	55.0	15.93	6.000	0.460	795.6	7.07	88.4	21.2	1.15	7.1
"	46.0	13.53	6.000	0.322	733.2	7.36	81.5	19.9	1.21	6.6
15	75.0	22.06	6.292	0.882	691.2	5.60	92.2	30.7	1.18	9.8
"	70.0	20.59	6.194	0.784	663.7	5.68	88.5	29.0	1.19	9.4
"	65.0	19.12	6.096	0.686	636.1	5.77	84.8	27.4	1.20	9.0
"	60.0	17.67	6.000	0.590	609.0	5.87	81.2	26.0	1.21	8.7
"	55.0	16.18	5.746	0.656	511.0	5.62	68.1	17.1	1.02	5.9
"	50.0	14.71	5.648	0.558	483.4	5.73	64.5	16.0	1.04	5.7
"	45.0	13.24	5.550	0.460	455.9	5.87	60.8	15.1	1.07	5.4
"	42.0	12.48	5.500	0.410	441.8	5.95	58.9	14.6	1.08	5.3
"	36.0	10.63	5.500	0.289	405.1	6.17	54.0	13.5	1.13	4.9
12	55.0	16.18	5.611	0.821	321.0	4.45	53.5	17.5	1.04	6.2
"	50.0	14.71	5.489	0.699	303.4	4.54	50.6	16.1	1.05	5.9
"	45.0	13.24	5.366	0.576	285.7	4.65	47.6	14.9	1.06	5.6
"	40.0	11.84	5.250	0.460	269.0	4.77	44.8	13.8	1.08	5.3
"	35.0	10.29	5.086	0.436	228.3	4.71	38.0	10.1	0.99	4.0
"	31.5	9.26	5.000	0.350	215.8	4.83	36.0	9.5	1.01	3.8
"	27.5	8.04	5.000	0.255	199.6	4.98	33.3	8.7	1.04	3.5
10	40.0	11.76	5.099	0.749	158.7	3.67	31.7	9.5	0.90	3.7
"	35.0	10.29	4.952	0.602	146.4	3.77	29.3	8.5	0.91	3.4
"	30.0	8.82	4.805	0.455	134.2	3.90	26.8	7.7	0.93	3.2
"	25.0	7.37	4.660	0.310	122.1	4.07	24.4	6.9	0.97	3.0
"	22.0	6.52	4.670	0.232	113.9	4.18	22.8	6.4	0.99	2.7

\* See notes on next page.

(Table continued on next page.)

## Properties of Carnegie Standard I-Beams—Steel.—Continued.

Depth of Beam.	Weight per Foot.	Area of Section.	Width of Flange.	Thickness of Web.	Neutral Axis Coincident with Center Line of Web.			Neutral Axis Perpendicular to Web at Center.		
					Moment of Inertia.	Radius of Gyration.	Section Modulus.	Moment of Inertia.	Radius of Gyration.	Section Modulus.
in.	lb.	sq. in.	in.	in.	in. <sup>4</sup>	in.	in. <sup>3</sup>	in. <sup>4</sup>	in.	in. <sup>3</sup>
9	35.0	10.29	4.772	0.732	111.8	3.29	24.8	7.3	0.84	3.1
"	30.0	8.82	4.609	0.569	101.9	3.40	22.6	6.4	0.85	2.8
"	25.0	7.35	4.446	0.406	91.9	3.54	20.4	5.7	0.88	2.5
"	21.0	6.31	4.330	0.290	84.9	3.67	18.9	5.2	0.90	2.4
8	25.5	7.50	4.271	0.541	68.4	3.02	17.1	4.8	0.80	2.2
"	23.0	6.76	4.179	0.449	64.5	3.09	16.1	4.4	0.81	2.1
"	20.5	6.03	4.087	0.357	60.6	3.17	15.2	4.1	0.82	2.0
"	18.0	5.33	4.000	0.270	56.9	3.27	14.2	3.8	0.84	1.9
"	17.5	5.15	4.330	0.210	58.3	3.37	14.6	4.5	0.93	2.1
7	20.0	5.88	3.868	0.458	42.2	2.68	12.1	3.2	0.74	1.7
"	17.5	5.15	3.763	0.353	39.2	2.76	11.2	2.9	0.76	1.6
"	15.0	4.42	3.660	0.250	36.2	2.86	10.4	2.7	0.78	1.5
6	17.25	5.07	3.575	0.475	26.2	2.27	8.7	2.4	0.68	1.3
"	14.75	4.34	3.452	0.352	24.0	2.35	8.0	2.1	0.69	1.2
"	12.25	3.61	3.330	0.230	21.8	2.46	7.3	1.9	0.72	1.1
5	14.75	4.34	3.294	0.504	15.2	1.87	6.1	1.7	0.63	1.0
"	12.25	3.60	3.147	0.357	13.6	1.94	5.5	1.5	0.63	0.92
"	9.75	2.87	3.000	0.210	12.1	2.05	4.8	1.2	0.65	0.82
4	10.5	3.09	2.880	0.410	7.1	1.52	3.6	1.0	0.57	0.70
"	9.5	2.79	2.807	0.337	6.8	1.55	3.4	0.93	0.58	0.66
"	8.5	2.50	2.733	0.263	6.4	1.59	3.2	0.85	0.58	0.62
"	7.5	2.21	2.660	0.190	6.0	1.64	3.0	0.77	0.59	0.58
3	7.5	2.21	2.521	0.361	2.9	1.15	1.9	0.60	0.52	0.48
"	6.5	1.91	2.423	0.263	2.7	1.19	1.8	0.53	0.52	0.44
"	5.5	1.63	2.330	0.170	2.5	1.23	1.7	0.46	0.53	0.40

$L$  = safe loads in pounds, uniformly distributed;  $l$  = span in feet;  
 $M$  = moments of forces in foot-pounds;  $f$  = fiber stress.

$$Ll = 8M = \frac{8fS}{12}; \quad L = \frac{2}{3} \frac{fS}{l}; \quad \text{for } f = 16,000 \text{ lb. per sq. in. (for build-}$$

$$\text{ings); } L = \frac{32,000 S}{3l} \text{ for } f = 12,500 \text{ lb. per sq. in. (for bridges) } L = \frac{25,000 S}{3l}$$

## Properties of Carnegie Trough Plates — Steel.

Section Index.	Size, in Inches.	Weight per Foot.	Area of Section.	Thickness in Inches.	Moment of Inertia, Neutral Axis Parallel to Length.	Section Modulus, Axis as before.	Radius of Gyration, Axis as before.
		lb.	sq. in.		$I$	$S$	$r$
M 10	9 1/2 × 3 3/4	16.3	4.78	1/2	3.7	1.4	0.91
M 11	9 1/2 × 3 3/4	18.0	5.28	9/16	4.1	1.6	0.91
M 12	9 1/2 × 3 3/4	19.7	5.79	5/8	4.6	1.8	0.90
M 13	9 1/2 × 3 3/4	21.4	6.30	11/16	5.0	2.0	0.90
M 14	9 1/2 × 3 3/4	23.2	6.97	3/4	5.5	2.2	0.90

**Safe Loads, in Thousands of Pounds, Uniformly Distributed for Carnegie Steel I-Beams.**

Span, Ft.	27 in.	24-inch.			21 in.	20-inch.		18-inch.		15-inch.		
	83 lb.	105 lb.	80 lb.	69½ lb.	57½ lb.	80 lb.	65 lb.	75 lb.	46 lb.	60 lb.	42 lb.	36 lb.
4	.....	.....	.....	.....	.....	.....	.....	.....	.....	177.0	.....	.....
5	.....	.....	.....	.....	.....	.....	.....	.....	.....	173.2	123.0	.....
6	.....	.....	.....	.....	.....	240.0	200.0	202.3	.....	144.4	104.8	86.7
7	.....	.....	240.0	.....	.....	223.4	178.2	193.2	115.9	123.7	89.8	82.3
8	.....	300.0	231.9	.....	150.0	195.5	155.9	169.1	108.6	108.3	78.5	72.0
9	229.0	277.7	206.1	187.2	138.6	173.8	138.6	150.3	96.6	96.2	69.8	64.0
10	228.2	249.9	185.5	171.4	124.7	156.4	124.7	135.3	86.9	86.6	62.8	57.6
11	207.5	227.2	168.7	155.8	113.4	142.2	113.4	123.0	79.0	78.7	57.1	52.4
12	190.2	208.3	154.6	142.8	103.9	130.3	104.0	112.7	72.4	72.2	52.4	48.0
13	175.6	192.2	142.7	131.8	95.9	120.3	96.0	104.1	66.8	66.6	48.3	44.3
14	163.0	178.5	132.5	122.4	89.1	111.7	89.	96.6	62.1	61.9	44.9	41.2
15	152.2	166.6	123.7	114.3	83.1	104.3	83.2	90.2	57.9	57.7	41.9	38.4
16	142.6	156.2	116.0	107.1	77.9	97.7	78.0	84.5	54.3	54.1	39.3	36.0
17	134.3	147.0	109.1	100.8	73.4	92.0	73.4	79.6	51.1	50.9	37.0	33.9
18	126.8	138.8	103.1	95.2	69.3	86.9	69.3	75.1	48.3	48.1	34.9	32.0
19	120.1	131.5	97.6	90.2	65.6	82.3	65.7	71.2	45.7	45.6	33.1	30.3
20	114.1	125.0	92.8	85.7	62.4	78.2	62.4	67.6	43.4	43.3	31.4	28.8
21	108.7	119.0	88.3	81.6	59.4	74.5	59.4	64.4	41.4	41.2	29.9	27.4
22	103.7	113.6	84.3	77.9	56.7	71.1	56.7	61.5	39.5	39.4	28.6	26.2
23	99.2	108.7	80.7	74.5	54.2	68.0	54.2	58.8	37.8	37.7	27.3	25.1
24	95.1	104.1	77.3	71.4	52.0	65.2	52.0	56.4	36.2	36.1	26.2	24.0
25	91.3	100.0	74.2	68.6	49.9	62.6	49.9	54.1	34.8	34.6	25.1	23.0
26	87.8	96.1	71.4	65.9	48.0	60.2	48.0	52.0	33.4	33.3	24.2	22.2
27	84.5	92.6	68.7	63.5	46.2	57.9	46.2	50.1	32.2	32.1	23.3	21.3
28	81.5	89.3	66.3	61.2	44.5	55.9	44.6	48.3	31.0	30.9	22.4	20.6
29	78.7	86.2	64.0	59.1	43.0	53.9	43.0	46.6	30.0	29.9	21.7	19.9
30	76.1	83.3	61.8	57.1	41.6	52.1	41.6	45.1	29.0	28.9	20.9	19.2
31	73.6	80.6	59.8	55.3	40.2	50.5	40.2	43.6	28.0	27.9	20.3	18.6
32	71.3	78.1	58.0	53.6	39.0	48.9	39.0	42.3	27.2	27.1	19.6	18.0
33	69.2	75.7	56.2	51.9	37.8	47.4	37.8	41.0	26.3	.....	.....	.....
34	67.1	73.5	54.6	50.4	36.7	46.0	36.7	39.8	25.6	.....	.....	.....
35	65.2	71.4	53.0	49.0	35.6	44.7	35.6	38.6	24.8	.....	.....	.....
36	63.4	69.4	51.5	47.6	34.6	43.4	34.7	37.6	24.1	.....	.....	.....
37	61.7	67.5	50.1	46.3	33.7	42.3	33.7	36.6	23.5	.....	.....	.....
38	60.1	65.8	48.8	45.1	32.8	41.2	32.8	35.6	22.9	.....	.....	.....
39	58.5	64.1	47.6	43.9	32.0	40.1	32.0	.....	.....	.....	.....	.....
40	57.1	62.5	46.4	42.8	31.2	39.1	31.2	.....	.....	.....	.....	.....
41	55.7	61.0	45.3	41.8	30.4	38.1	30.4	.....	.....	.....	.....	.....
42	54.3	59.5	44.2	40.8	29.7	37.2	29.7	.....	.....	.....	.....	.....
43	53.1	58.1	43.1	39.9	29.0	.....	.....	.....	.....	.....	.....	.....
44	51.9	56.8	42.2	38.9	28.3	.....	.....	.....	.....	.....	.....	.....
45	50.7	55.5	41.2	38.1	.....	.....	.....	.....	.....	.....	.....	.....
46	49.6	54.3	40.3	37.3	.....	.....	.....	.....	.....	.....	.....	.....
47	48.6	53.2	39.5	36.5	.....	.....	.....	.....	.....	.....	.....	.....
48	47.5	52.1	38.7	35.7	.....	.....	.....	.....	.....	.....	.....	.....
49	46.6	51.0	37.9	35.0	.....	.....	.....	.....	.....	.....	.....	.....
50	45.6	50.0	37.1	34.3	.....	.....	.....	.....	.....	.....	.....	.....

Table continued on next page.

Loads above upper horizontal lines will produce maximum allowable shear in webs. Loads below lower horizontal lines will produce excessive deflections and must not be used with plastered ceilings. Maximum fiber stress, 16,000 lb. per sq. in. Safe loads given include the weight of beam, which should be deducted to give net load.

**Safe Loads, in Thousands of Pounds, Uniformly Distributed for  
Carnegie Steel I-Beams.—Continued.**

Span, Ft.	12-inch.			10-inch.		9-in.	8-inch.		7-in.	6-in.	5-in.	4-in.	3-in.							
	40 lb.	31½ lb.	27½ lb.	25 lb.	22 lb.	21 lb.	18 lb.	17½ lb.	15 lb.	12¼ lb.	9¾ lb.	7½ lb.	5½ lb.							
1	....	...	...	...	...	...	...	...	...	...	...	...	10.2							
2	....	...	...	...	...	...	...	...	...	27.6	21.0	15.2	8.8							
3	....	...	...	...	...	52.2	43.2	...	35.0	25.8	17.2	10.6	5.9							
4	110.4	84.0	...	62.0	...	50.3	37.9	33.6	27.6	19.4	12.9	8.0	4.4							
5	95.6	76.7	61.2	52.1	46.4	40.3	30.3	31.1	22.1	15.5	10.3	6.4	3.5							
6	79.7	63.9	59.1	43.4	40.5	33.6	25.3	25.9	18.4	12.9	8.6	5.3	2.9							
7	68.3	54.8	50.7	37.2	34.7	28.8	21.7	22.2	15.8	11.1	7.4	4.5	2.5							
8	59.8	48.0	44.4	32.6	30.4	25.2	19.0	19.4	13.8	9.7	6.4	4.0	2.2							
9	53.1	42.6	39.4	28.9	27.0	22.4	16.9	17.3	12.3	8.6	5.7	3.5	...							
10	47.8	38.4	35.5	26.0	24.3	20.1	15.2	15.6	11.0	7.7	5.2	3.2	...							
11	43.5	34.9	32.3	23.7	22.1	18.3	13.8	14.1	10.0	7.0	4.7	...	...							
12	39.8	32.0	29.6	21.7	20.2	16.8	12.6	13.0	9.2	6.5	4.3	...	...							
13	36.8	29.5	27.3	20.0	18.7	15.5	11.7	12.0	8.5	6.0	...	...	...							
14	34.2	27.4	25.3	18.6	17.4	14.4	10.8	11.1	7.9	5.5	Loads above the upper horizontal lines will produce maximum allowable shear in webs. Loads below lower horizontal lines will produce excessive deflections, and should not be used with plastered ceilings. Maximum fiber stress, 16,000 lb. per sq. in. Safe loads given include the weight of beam, which should be deducted to give net load.									
15	31.9	25.6	23.7	17.4	16.2	13.4	10.1	10.4	7.4	...										
16	29.9	24.0	22.2	16.3	15.2	12.6	9.5	9.7	6.9	...										
17	28.1	22.6	20.9	15.3	14.3	11.8	8.9	9.2	...	...										
18	26.6	21.3	19.7	14.5	13.5	11.2	8.4	8.6	...	...	...	...	...							
19	25.2	20.2	18.7	13.7	12.8	10.6	horizontal lines will produce excessive deflections, and should not be used with plastered ceilings. Maximum fiber stress, 16,000 lb. per sq. in. Safe loads given include the weight of beam, which should be deducted to give net load.													
20	23.9	19.2	17.7	13.0	12.1	10.1								...	...	...	...	...	...	...
21	22.8	18.3	16.9	12.4	11.6	...								...	...	...	...	...	...	...
22	21.7	17.4	16.1	11.8	11.0	...								...	...	...	...	...	...	...
23	20.8	16.7	15.4	...	...	...								...	...	...	...	...	...	...
24	19.9	16.0	14.8	...	...	...								...	...	...	...	...	...	...
25	19.1	15.3	14.2	...	...	...								...	...	...	...	...	...	...
26	18.4	14.8	13.6	...	...	...								...	...	...	...	...	...	...

**Properties of Carnegie Corrugated Plates — Steel.**

Section Index.	Size, in Inches.	Weight per Foot.	Area of Section.	Thickness in Inches.	Moment of Inertia, Neutral Axis Parallel to Length.	Section Modulus, Axis as before.	Radius of Gyration, Axis as before.
		lb.	sq. in.		<i>I</i>	<i>S</i>	<i>r</i>
M 30	8¾ × 11½	8.1	2.38	¼	0.64	0.8	0.52
M 31	8¾ × 19/16	10.1	2.96	5/16	0.95	1.1	0.57
M 32	8¾ × 15/8	12.0	3.53	3/8	1.3	1.4	0.62
M 33	12³/16 × 23/4	17.8	5.22	3/8	4.8	3.3	0.96
M 34	12³/16 × 213/16	20.8	6.10	7/16	5.8	3.9	0.98
M 35	12³/16 × 27/8	23.7	6.97	1/2	6.8	4.5	0.99



**Spacing of Carnegie Steel I-Beams for Uniform Load of 100 Lbs. per Square Foot.**

(Figures in table give the proper distance, feet, center to center of beams.)

Distance between supports.	27-in.	24-inch.			21-in.	20-inch.		18-inch.		15-inch.		
		83 lb.	105 lb.	80 lb.	69½ lb.	57½ lb.	80 lb.	65 lb.	75 lb.	46 lb.	60 lb.	42 lb.
Ft.												
10	228.2	249.9	185.5	171.4	124.7	156.4	124.8	135.3	86.9	86.6	62.8	57.6
11	188.6	206.5	153.3	141.6	103.1	129.3	103.1	111.8	71.8	71.6	51.9	47.6
12	158.5	173.6	128.8	119.0	86.6	108.6	86.6	93.9	60.4	60.1	43.6	40.0
13	135.0	147.9	109.8	101.4	73.8	92.6	73.8	80.0	51.4	51.3	37.2	34.1
14	116.4	127.5	94.7	87.4	63.6	79.8	63.7	69.0	44.3	44.2	32.1	29.4
15	101.4	111.1	82.5	76.2	55.4	69.5	54.4	60.1	38.6	38.5	27.9	25.6
16	89.2	97.6	72.5	66.9	48.7	61.1	48.7	52.8	33.9	33.8	24.5	22.5
17	79.0	86.5	64.2	53.3	43.2	54.1	43.2	46.8	30.1	30.0	21.7	19.9
18	70.4	77.1	57.3	52.9	38.5	48.3	38.5	41.8	26.8	26.7	19.4	17.8
19	63.2	69.2	51.4	47.5	34.5	43.3	34.6	37.5	24.1	24.0	17.4	16.0
20	57.1	62.5	46.4	42.8	31.2	39.1	31.2	33.8	21.7	21.7	15.7	14.4
21	51.8	56.7	42.1	38.9	28.3	35.5	28.3	30.7	19.7	19.6	14.3	13.1
22	47.2	51.6	38.3	35.4	25.8	32.3	25.8	28.0	18.0	17.9	13.0	11.9
23	43.1	47.2	35.1	32.4	23.6	29.6	23.6	25.6	16.4	16.4	11.9	10.9
24	39.6	43.4	32.2	29.8	21.7	27.2	21.7	23.5	15.1	15.0	10.9	10.0
25	36.5	40.0	29.7	27.4	20.0	25.0	20.0	21.6	13.9	13.9	10.1	9.2
26	33.8	37.0	27.5	25.4	18.5	23.1	18.5	20.0	12.9	12.8	9.3	8.5
27	31.3	34.3	25.5	23.5	17.1	21.5	17.1	18.6	11.9	...	...	...
28	29.1	31.9	23.7	21.9	15.9	20.0	15.9	17.3	11.1	...	...	...

Distance between supports.	12-inch.			10-inch.		9-in.	8-inch.		7-in.	6-in.	5-in.	4-in.	3-in.
	40 lb.	31½ lb.	27½ lb.	25 lb.	22 lb.	21 lb.	18 lb.	17½ lb.	15 lb.	12¼ lb.	9¾ lb.	7½ lb.	5½ lb.
Ft.													
5	...	...	...	...	...	..	60.7	62.2	44.2	31.0	20.6	12.7	7.1
5½	...	...	...	...	...	..	50.1	51.4	36.5	25.6	17.1	10.5	5.8
6	132.8	106.6	98.6	72.4	67.5	55.9	42.1	43.2	30.7	21.5	14.3	8.8	4.9
6½	...	...	...	...	...	..	35.9	36.8	26.1	18.3	12.2	7.5	4.2
7	97.6	78.3	72.4	53.2	49.6	41.1	31.0	31.8	22.5	15.8	10.5	6.5	3.6
8	74.7	60.0	55.4	40.7	38.0	31.5	23.7	24.3	17.3	12.1	8.1	5.0	...
9	59.0	47.4	43.8	32.2	30.0	24.9	18.7	19.2	13.6	9.6	6.4	3.9	...
10	47.8	38.4	35.5	26.1	24.3	20.1	15.2	15.6	11.0	7.8	5.2	3.2	...
11	39.5	31.7	29.3	21.5	20.1	16.6	12.5	12.9	9.1	6.4	4.3	..	...
12	33.2	26.6	24.6	18.1	16.9	14.0	10.5	10.8	7.7	5.4	3.6	..	...
13	28.3	22.7	21.0	15.4	14.4	11.9	9.0	9.2	6.5	4.6	...	..	...
14	24.4	19.6	18.1	13.3	12.4	10.3	7.7	7.9	5.6	4.0	...	..	...
15	21.3	17.1	15.8	11.6	10.8	9.0	6.7	6.9	4.9	...	...	..	...
16	18.7	15.0	13.9	10.2	9.5	7.9	5.9	6.1	4.3	...	...	..	...
17	16.5	13.3	12.3	9.0	8.4	7.0	5.3	5.4	...	...	...	..	...
18	14.8	11.8	11.0	8.0	7.5	6.2	4.7	4.8	...	...	...	..	...
19	13.2	10.6	9.8	7.2	6.7	5.6	...	...	...	...	...	..	...
20	12.0	9.6	8.9	6.5	6.1	5.0	...	...	...	...	...	..	...
21	10.8	8.7	8.1	5.9	5.5	..	...	...	...	...	...	..	...
22	9.9	7.9	7.3	5.4	5.0	..	...	...	...	...	...	..	...
23	9.0	7.3	6.7	...	...	..	...	...	...	...	...	..	...
24	8.3	6.7	6.2	...	...	..	...	...	...	...	...	..	...

For any other load than 100 lb. per sq. ft., divide the spacing given by the ratio the given load per sq. ft. bears to 100. Thus for a load of 150 lb. per sq. ft. divide by 1.5. Maximum fiber stress 16,000 lb. per sq. in.

Spacings given below the dotted horizontal lines will produce excessive deflection, and should not be used with plastered ceilings.

## Properties of Carnegie Standard Channels — Steel.

Depth of Channel.	Weight per Foot.	Area of Section.	Thickness of Web.	Width of Flange.	Moment of Inertia, Neutral Axis Perpendicular to Web at Center.	Moment of Inertia, Neutral Axis Parallel with Center Line of Web.	Radius of Gyration, Neutral Axis Perpendicular to Web at Center.	Radius of Gyration, Neutral Axis Parallel with Center Line of Web.	Section Modulus, Neutral Axis Perpendicular to Web at Center.	Section Modulus, Neutral Axis Parallel with Center Line of Web.	Distance of Center of Gravity from Outside of Web.
in.	lbs.	sq. in.	in.	in.	$I$	$I'$	$r$	$r'$	$S$	$S'$	$e$
15	55.	16.18	0.82	3.82	430.2	12.2	5.16	0.868	57.4	4.1	0.82
"	50.	14.71	0.72	3.72	402.7	11.2	5.23	0.873	53.7	3.8	0.80
"	45.	13.24	0.62	3.62	375.1	10.3	5.32	0.882	50.0	3.6	0.79
"	40.	11.76	0.52	3.52	347.5	9.4	5.43	0.893	46.3	3.4	0.78
"	35.	10.29	0.43	3.43	319.9	8.5	5.58	0.908	42.7	3.2	0.79
"	33.	9.90	0.40	3.40	312.6	8.2	5.62	0.912	41.7	3.2	0.79
12	40.	11.76	0.76	3.42	196.9	6.6	4.09	0.751	32.8	2.5	0.72
"	35.	10.29	0.64	3.30	179.3	5.9	4.17	0.757	29.9	2.3	0.69
"	30.	8.82	0.51	3.17	161.7	5.2	4.28	0.768	26.9	2.1	0.68
"	25.	7.35	0.39	3.05	144.0	4.5	4.43	0.785	24.0	1.9	0.68
"	20 1/2	6.03	0.28	2.94	128.1	3.9	4.61	0.805	21.4	1.7	0.70
10	35.	10.29	0.82	3.18	115.5	4.7	3.35	0.672	23.1	1.9	0.70
"	30.	8.82	0.68	3.04	103.2	4.0	3.42	0.672	20.7	1.7	0.65
"	25.	7.35	0.53	2.89	91.0	3.4	3.52	0.680	18.2	1.5	0.62
"	20.	5.88	0.38	2.74	78.7	2.9	3.66	0.696	15.7	1.3	0.61
"	15.	4.46	0.24	2.60	66.9	2.3	3.87	0.718	13.4	1.2	0.64
9	25.	7.35	0.62	2.82	70.7	3.0	3.10	0.637	15.7	1.4	0.62
"	20.	5.88	0.45	2.65	60.8	2.5	3.21	0.646	13.5	1.2	0.59
"	15.	4.41	0.29	2.49	50.9	2.0	3.40	0.665	11.3	1.0	0.59
"	13 1/4	3.89	0.23	2.43	47.3	1.8	3.49	0.674	10.5	0.97	0.61
8	21 1/4	6.25	0.58	2.62	47.8	2.3	2.77	0.600	11.9	1.1	0.59
"	18 3/4	5.51	0.49	2.53	43.8	2.0	2.82	0.603	11.0	1.0	0.57
"	16 1/4	4.78	0.40	2.44	39.9	1.8	2.89	0.610	10.0	0.95	0.56
"	13 3/4	4.04	0.31	2.35	36.0	1.6	2.98	0.619	9.0	0.87	0.56
"	11 1/4	3.35	0.22	2.26	32.3	1.3	3.11	0.630	8.1	0.79	0.58
7	19 3/4	5.81	0.63	2.51	33.2	1.9	2.39	0.565	9.5	0.96	0.58
"	17 1/4	5.07	0.53	2.41	30.2	1.6	2.44	0.564	8.6	0.87	0.56
"	14 3/4	4.34	0.42	2.30	27.2	1.4	2.50	0.568	7.8	0.79	0.54
"	12 1/4	3.60	0.32	2.20	24.2	1.2	2.59	0.575	6.9	0.71	0.53
"	9 3/4	2.85	0.21	2.09	21.1	0.98	2.72	0.586	6.0	0.63	0.55
6	15 1/2	4.56	0.56	2.28	19.5	1.3	2.07	0.529	6.5	0.74	0.55
"	13.	3.82	0.44	2.16	17.3	1.1	2.13	0.529	5.8	0.65	0.52
"	10 1/2	3.09	0.32	2.04	15.1	0.88	2.21	0.534	5.0	0.57	0.50
"	8.	2.38	0.20	1.92	13.0	0.70	2.34	0.542	4.3	0.50	0.52
5	11 1/2	3.38	0.48	2.04	10.4	0.82	1.75	0.493	4.2	0.54	0.51
"	9.	2.65	0.33	1.89	8.9	0.64	1.83	0.493	3.6	0.45	0.48
"	6 1/2	1.95	0.19	1.75	7.4	0.48	1.95	0.498	3.0	0.38	0.49
4	7 1/4	2.13	0.33	1.73	4.6	0.44	1.46	0.455	2.3	0.35	0.46
"	6 1/4	1.84	0.25	1.65	4.2	0.38	1.51	0.454	2.1	0.32	0.46
"	5 1/4	1.55	0.18	1.58	3.8	0.32	1.56	0.453	1.9	0.29	0.46
3	6.	1.76	0.36	1.60	2.1	0.31	1.08	0.421	1.4	0.27	0.46
"	5.	1.47	0.26	1.50	1.8	0.25	1.12	0.415	1.2	0.24	0.44
"	4.	1.19	0.17	1.41	1.6	0.20	1.17	0.409	1.1	0.21	0.44

$L$  = safe load in pounds, uniformly distributed;  $l$  = span in feet;  
 $M$  = moment of forces in foot-pounds;  $f$  = fiber stress.

$$Ll = 8M = \frac{8fS}{12}; \quad L = \frac{2fS}{3l}; \quad \text{for } f = 16,000 \text{ lbs. per sq. in. (for build-}$$

$$\text{ings); } L = \frac{32,000 S}{3l} \text{ for } f = 12,500 \text{ lb. per sq. in. (for bridges), } L = \frac{25,000 S}{3l}$$

Maximum Safe Load for Carnegie Channels in Thousands of Pounds.

Span, Ft.	Depth and Weight of Sections.										
	15 in. 33 lb.	13 in. 32 lb.	12 in. 20½ lb.	10 in. 15 lb.	9 in. 13¼ lb.	8 in. 11¼ lb.	7 in. 9¾ lb.	6 in. 8 lb.	5 in. 6½ lb.	4 in. 5¼ lb.	3 in. 4 lb.
1	....	....	....	....	....	....	....	24.0	19.0	14.4	10.2
2	....	....	....	48.0	41.4	35.2	29.4	23.1	15.8	10.1	5.8
3	120.0	97.5	67.2	47.6	37.4	28.7	21.4	15.4	10.5	6.7	3.9
4	111.1	97.5	56.9	35.7	28.0	21.5	16.1	11.6	7.9	5.1	2.9
5	88.9	78.0	45.5	28.5	22.4	17.2	12.9	9.2	6.3	4.1	2.3
6	74.1	65.0	38.0	23.8	18.7	14.4	10.7	7.7	5.3	3.4	1.9
7	63.5	55.7	32.5	20.4	16.0	12.3	9.2	6.6	4.5	2.9	1.7
8	55.6	48.7	28.5	17.8	14.0	10.8	8.0	5.8	4.0	2.5	1.5
9	49.4	43.3	25.3	15.9	12.5	9.6	7.1	5.1	3.5	2.2	....
10	44.5	39.0	22.8	14.3	11.2	8.6	6.4	4.6	3.2	2.0	....
11	40.4	35.4	20.7	13.0	10.2	7.8	5.8	4.2	2.9	....	....
12	37.0	32.5	19.0	11.9	9.3	7.2	5.4	3.9	2.6	....	....
13	34.2	30.0	17.5	11.0	8.6	6.6	4.9	3.6	....	....	....
14	31.8	27.9	16.3	10.2	8.0	6.2	4.6	3.3	....	....	....
15	29.6	26.0	15.2	9.5	7.5	5.7	4.3	....	....	....	....
16	27.8	24.4	14.2	8.9	7.0	5.4	4.0	....	....	....	....
17	26.1	22.9	13.4	8.4	6.6	5.1	....	....	....	....	....
18	24.7	21.7	12.7	7.9	6.2	4.8	....	....	....	....	....
19	23.4	20.5	12.0	7.5	5.9	....	....	....	....	....	....
20	22.3	19.5	11.4	7.1	5.6	....	....	....	....	....	....
21	21.2	18.6	10.8	6.8	....	....	....	....	....	....	....
22	20.2	17.7	10.4	6.5	....	....	....	....	....	....	....
23	19.3	17.0	9.9	....	....	....	....	....	....	....	....
24	18.5	16.2	9.5	....	....	....	....	....	....	....	....
25	17.8	15.6	9.1	....	....	....	....	....	....	....	....
26	17.1	15.0	8.8	....	....	....	....	....	....	....	....
27	16.5	14.4	....	....	....	....	....	....	....	....	....
28	15.9	13.9	....	....	....	....	....	....	....	....	....
29	15.3	....	....	....	....	....	....	....	....	....	....
30	14.8	....	....	....	....	....	....	....	....	....	....
31	14.3	....	....	....	....	....	....	....	....	....	....
32	13.9	....	....	....	....	....	....	....	....	....	....

Loads above upper horizontal lines will produce maximum allowable shear in webs. Loads below lower horizontal lines will produce excessive deflections. Maximum bending stress, 16,000 lb. per sq. in.

Properties of Carnegie T-Shapes — Steel.

Size, Flange by Stem.	Minimum Thickness, In.		Weight per Foot, Lb.	Area of Section, Square Inches.	Neutral Axis through C. of G. Parallel to Flange.				Neutral Axis Coincident with Center Line of Stem.		
	Flange.	Stem.			Moment of Inertia.	Radius of Gyration, In.	Section Modulus.	Distance Neutral Axis to Top of Flange, In.	Moment of Inertia.	Radius of Gyration, In.	Section Modulus.
5 X 3	1/2	13/32	13.4	3.93	2.4	0.78	1.1	0.73	5.4	1.17	2.2
5 X 21/2	3/8	7/16	10.9	3.18	1.5	0.68	0.78	0.63	4.1	1.14	1.6
4 1/2 X 3 1/2	7/16	11/16	15.7	4.60	5.1	1.05	2.1	1.11	3.7	0.90	1.7
4 1/2 X 3	3/8	3/8	9.8	2.88	2.1	0.84	0.91	0.74	3.0	1.02	1.3
4 1/2 X 3	5/16	5/16	8.4	2.46	1.8	0.85	0.78	0.71	2.5	1.01	1.1
4 1/2 X 2 1/2	3/8	3/8	9.2	2.68	1.2	0.67	0.63	0.59	3.0	1.05	1.3
4 1/2 X 2 1/2	5/16	5/16	7.8	2.29	1.0	0.68	0.54	0.57	2.5	1.05	1.1

(Table continued on next page.)



## Properties of Carnegie T-Shapes—Steel.—Continued.

Size, Flange by Stem.		Mini- mum Thick- ness, In.		Weight per Foot, Lb.	Area of Section, Square Inches.	Neutral Axis through C. of G. Parallel to Flange.				Neutral Axis Co- incident with Cen- ter Line of Stem.		
		Flange.	Stem.			Moment of Inertia.	Radius of Gyration, In.	Section Modulus.	Distance Neu- tral Axis to Top of Flange, In.	Moment of Inertia.	Radius of Gyration, In.	Section Modulus.
In.												
4	× 5	1/2	1/2	15.3	4.50	10.8	1.55	3.1	1.56	2.8	0.79	1.4
4	× 5	3/8	3/8	11.9	3.49	8.5	1.56	2.4	1.51	2.1	0.78	1.1
4	× 4 1/2	1/2	1/2	14.4	4.23	7.9	1.37	2.5	1.37	2.8	0.81	1.4
4	× 4 1/2	3/8	3/8	11.2	3.29	6.3	1.39	2.0	1.31	2.1	0.80	1.1
4	× 4	1/2	1/2	13.5	3.97	5.7	1.20	2.0	1.18	2.8	0.84	1.4
4	× 4	3/8	3/8	10.5	3.09	4.5	1.21	1.6	1.13	2.1	0.83	1.1
4	× 3	3/8	3/8	9.2	2.68	2.0	0.86	0.90	0.78	2.1	0.89	1.1
4	× 3	5/16	5/16	7.8	2.29	1.7	0.87	0.77	0.75	1.8	0.88	0.88
4	× 2 1/2	3/8	3/8	8.5	2.48	1.2	0.69	0.62	0.62	2.1	0.92	1.0
4	× 2 1/2	5/16	5/16	7.2	2.12	1.0	0.69	0.53	0.60	1.8	0.91	0.88
4	× 2	3/8	3/8	7.8	2.27	0.60	0.52	0.40	0.48	2.1	0.96	1.1
4	× 2	5/16	5/16	6.7	1.95	0.53	0.52	0.34	0.46	1.8	0.95	0.88
3 1/2	× 4	1/2	1/2	12.6	3.70	5.5	1.21	2.0	1.24	1.9	0.72	1.1
3 1/2	× 4	3/8	3/8	9.8	2.88	4.3	1.23	1.5	1.19	1.4	0.70	0.81
3 1/2	× 3 1/2	1/2	1/2	11.7	3.44	3.7	1.04	1.5	1.05	1.9	0.74	1.1
3 1/2	× 3 1/2	3/8	3/8	9.2	2.68	3.0	1.05	1.2	1.01	1.4	0.73	0.81
3 1/2	× 3	1/2	1/2	10.8	3.17	2.4	0.87	1.1	0.88	1.9	0.77	1.1
3 1/2	× 3	3/8	3/8	8.5	2.48	1.9	0.88	0.89	0.83	1.4	0.75	0.81
3 1/2	× 3	5/16	3/8	7.5	2.20	1.8	0.91	0.85	0.85	1.2	0.74	0.68
3	× 4	1/2	1/2	11.7	3.44	5.2	1.23	1.9	1.32	1.2	0.59	0.81
3	× 4	7/16	7/16	10.5	3.06	4.7	1.23	1.7	1.29	1.1	0.59	0.70
3	× 4	3/8	3/8	9.2	2.68	4.1	1.24	1.5	1.27	0.90	0.58	0.60
3	× 3 1/2	1/2	1/2	10.8	3.17	3.5	1.06	1.5	1.12	1.2	0.62	0.80
3	× 3 1/2	7/16	7/16	9.7	2.83	3.2	1.06	1.3	1.10	1.0	0.60	0.69
3	× 3 1/2	3/8	3/8	8.5	2.48	2.8	1.07	1.2	1.07	0.93	0.61	0.62
3	× 3	1/2	1/2	9.9	2.91	2.3	0.88	1.1	0.93	1.2	0.64	0.80
3	× 3	7/16	7/16	8.9	2.59	2.1	0.89	0.98	0.91	1.0	0.63	0.70
3	× 3	3/8	3/8	7.8	2.27	1.8	0.90	0.86	0.88	0.90	0.63	0.60
3	× 3	5/16	5/16	6.7	1.95	1.6	0.90	0.74	0.86	0.75	0.62	0.50
3	× 2 1/2	3/8	3/8	7.1	2.07	1.1	0.72	0.60	0.71	0.89	0.66	0.59
3	× 2 1/2	5/16	5/16	6.1	1.77	0.94	0.73	0.52	0.68	0.75	0.65	0.50
3	× 2 1/2	1/4	1/4	5.0	1.47	0.78	0.73	0.43	0.66	0.61	0.64	0.40
2 1/2	× 3	3/8	3/8	7.1	2.07	1.7	0.91	0.84	0.95	0.53	0.51	0.42
2 1/2	× 3	5/16	5/16	6.1	1.77	1.5	0.92	0.72	0.92	0.44	0.50	0.35
2 1/2	× 2 1/2	3/8	3/8	6.4	1.87	1.0	0.74	0.59	0.76	0.52	0.53	0.42
2 1/2	× 1 1/4	3/16	3/16	2.87	0.84	0.08	0.31	0.09	0.32	0.29	0.58	0.23
2 1/4	× 2 1/4	5/16	5/16	4.9	1.43	0.65	0.67	0.41	0.68	0.33	0.48	0.29
2	× 2	5/16	5/16	4.3	1.26	0.44	0.59	0.31	0.61	0.23	0.43	0.23
2	× 1 1/2	1/4	1/4	3.09	0.91	0.16	0.42	0.15	0.42	0.18	0.45	0.18
1 3/4	× 1 3/4	1/4	1/4	3.09	0.91	0.23	0.51	0.19	0.54	0.12	0.37	0.14
1 1/2	× 1 1/2	1/4	1/4	2.47	0.73	0.15	0.45	0.14	0.47	0.08	0.32	0.10
1 1/4	× 1 1/4	1/4	1/4	2.02	0.59	0.08	0.37	0.10	0.40	0.05	0.28	0.07
1	× 1	3/16	3/16	1.25	0.37	0.03	0.29	0.05	0.32	0.02	0.22	0.04

Ten light-weight T's of sizes under 2 1/2 × 2 1/2 in. are omitted.



Maximum Safe Loads on Carnegie T-Shapes.

Allowable Uniform Load in Thousands of Pounds. Neutral Axis Parallel to Flange. Maximum Bending Stress, 16,000 Pounds Per Square Inch.

Size.		Wgt. per Foot, Lb.	1 Ft. Span		Maximum Span. 360 × Deflection.		Size.		Wgt. per Foot, Lb.	1 Ft. Span		Maximum Span. 360 × Deflection.	
Flange, In.	Stem, In.		Safe Load.	Safe Load.	Lgth., Feet.	Flange, In.	Stem, In.	Safe Load.		Safe Load.	Lgth., Feet.		
5	3	13.4	11.41	1.25	9.1	3	3 1/2	9.7	14.19	1.46	9.7		
	2 1/2	10.9	8.96	1.20	7.5		3 1/2	8.5	12.37	1.26	9.8		
4 1/2	3 1/2	15.7	22.72	2.37	9.6		3	9.9	11.73	1.41	8.3		
	3	9.8	9.71	1.07	9.1		3	8.9	10.45	1.24	8.4		
	3	8.4	8.32	0.90	9.2		3	7.8	9.17	1.08	8.5		
	2 1/2	9.2	6.72	0.87	7.7		3	6.7	7.89	0.92	8.6		
	2 1/2	7.8	5.76	0.74	7.8		2 1/2	7.1	6.40	0.89	7.2		
4	5	15.3	33.39	2.40	13.9		2 1/2	6.1	5.55	0.76	7.3		
	5	11.9	25.92	1.84	14.1		2 1/2	5.0	4.59	0.62	7.4		
	4 1/2	14.4	27.09	2.15	12.6		2 1/2	3	7.1	8.96	1.08	8.3	
	4 1/2	11.2	21.12	1.65	12.8			3	6.1	7.68	0.91	8.4	
	4	13.5	21.55	1.89	11.4			2 1/2	6.4	6.29	0.90	7.0	
	4	10.5	16.85	1.45	11.6			2 1/2	5.5	5.33	0.75	7.1	
	3	9.2	9.60	1.08	8.9			1 1/4	2.87	0.93	0.25	3.7	
	3	7.8	8.21	0.90	9.1	2 1/4	2 1/4	4.9	4.37	0.69	6.3		
	2 1/2	8.5	6.61	0.87	7.6		2 1/4	4.1	3.41	0.53	6.4		
	2 1/2	7.2	5.65	0.73	7.7	2	2	4.3	3.31	0.59	5.6		
	2	7.8	4.27	0.70	6.1		2	3.56	2.77	0.49	5.7		
2	6.7	3.63	0.59	6.2	1 1/2		3.09	1.60	0.36	4.4			
3 1/2	4	12.6	21.12	1.90	11.1	1 3/4	1 3/4	3.09	2.03	0.41	4.9		
	4	9.8	16.53	1.46	11.3	1 1/2	2	2.45	2.03	0.37	5.5		
	3 1/2	11.7	16.32	1.65	9.9		1 1/2	2.47	1.49	0.36	4.1		
	3 1/2	9.2	12.69	1.27	10.0		1 1/2	1.94	1.17	0.27	4.3		
	3	10.8	12.05	1.42	8.5		1 1/4	1.25	0.57	0.15	3.7		
	3	8.5	9.49	1.09	8.7	1 1/4	1 1/4	2.02	1.01	0.30	3.4		
3	7.5	9.07	1.04	8.7	1 1/4		1.59	0.78	0.22	3.5			
3	4	11.7	20.69	1.92	10.8		5/8	0.88	0.14	0.07	1.9		
	4	10.5	18.35	1.68	10.9	1	1	1.25	0.49	0.18	2.7		
	4	9.2	16.11	1.47	11.0		1	0.89	0.35	0.12	2.9		
	3 1/2	10.8	15.89	1.66	9.6								

## Properties of Carnegie Z-Bars.

Depth of Web.	Width of Flange.	Thickness of Metal.	Weight per Foot.	Area of Section.	Mom. of Inertia. Neut. Axis thro' C. of Gr. Perpendicular to Web.	Mom. of Inertia. Neut. Axis thro' C. of Gr. Coincident with Web.	Section Modulus. Neut. Axis thro' C. of Gr. Perpendicular to Web.	Section Modulus. Neut. Axis thro' C. of Gr. Coincident with Web.	Radius of Gyration. Neut. Axis thro' C. of Gr. Perpendicular to Web.	Radius of Gyration. Neut. Axis through C. of Gr. Coincident with Web.	Radius of Gyration. Least Radius, Neut. Axis Diag.
in.	in.	in.	lb.	sq. in.	<i>I</i>	<i>I</i>	<i>S</i>	<i>S</i>	<i>r</i>	<i>r</i>	<i>r</i>
6	3 1/2	3/8	15.7	4.59	25.32	9.11	8.44	2.75	2.35	1.41	0.83
6 1/16	3 9/16	7/16	18.4	5.39	29.80	10.95	9.83	3.27	2.35	1.43	0.83
6 1/8	3 5/8	1/2	21.1	6.19	34.36	12.87	11.22	3.81	2.36	1.44	0.84
6	3 1/2	9/16	22.8	6.68	34.64	12.59	11.52	3.91	2.28	1.37	0.81
6 1/16	3 9/16	5/8	25.4	7.46	38.86	14.42	12.82	4.43	2.28	1.39	0.82
6 1/8	3 5/8	11/16	28.1	8.25	43.18	16.34	14.10	4.98	2.29	1.41	0.84
6	3 1/2	3/4	29.4	8.63	42.12	15.44	14.04	4.94	2.21	1.34	0.81
6 1/16	3 9/16	13/16	32.0	9.40	46.13	17.27	15.22	5.47	2.22	1.36	0.82
6 1/8	3 5/8	7/8	34.6	10.17	50.22	19.18	16.40	6.02	2.22	1.37	0.83
5	3 1/4	5/16	11.6	3.40	13.36	6.18	5.34	2.00	1.98	1.35	0.75
5 1/16	3 5/16	3/8	14.0	4.10	16.18	7.65	6.39	2.45	1.99	1.37	0.76
5 1/8	3 3/8	7/16	16.4	4.81	19.07	9.20	7.44	2.92	1.99	1.38	0.77
5	3 1/4	1/2	17.9	5.25	19.19	9.05	7.68	3.02	1.91	1.31	0.74
5 1/16	3 5/16	9/16	20.2	5.94	21.83	10.51	8.62	3.47	1.91	1.33	0.75
5 1/8	3 3/8	5/8	22.6	6.64	24.53	12.06	9.57	3.94	1.92	1.35	0.76
5	3 1/4	11/16	23.7	6.96	23.68	11.37	9.47	3.91	1.84	1.28	0.73
5 1/16	3 5/16	3/4	26.0	7.64	26.16	12.83	10.34	4.37	1.85	1.30	0.74
5 1/8	3 3/8	13/16	28.4	8.33	28.70	14.36	11.20	4.84	1.86	1.31	0.76
4	3 1/16	1/4	8.2	2.41	6.28	4.23	3.14	1.44	1.62	1.33	0.67
4 1/16	3 1/8	5/16	10.3	3.03	7.94	5.46	3.91	1.84	1.62	1.34	0.68
4 1/8	3 3/16	3/8	12.5	3.66	9.63	6.77	4.67	2.26	1.62	1.36	0.69
4	3 1/16	7/16	13.8	4.05	9.66	6.73	4.83	2.37	1.55	1.29	0.66
4 1/16	3 1/8	1/2	15.9	4.66	11.18	7.96	5.50	2.77	1.55	1.31	0.67
4 1/8	3 3/16	9/16	18.0	5.27	12.74	9.26	6.18	3.19	1.55	1.33	0.68
4	3 1/16	5/8	18.9	5.55	12.11	8.73	6.05	3.18	1.48	1.25	0.66
4 1/16	3 1/8	11/16	20.9	6.14	13.52	9.95	6.65	3.58	1.48	1.27	0.67
4 1/8	3 3/16	3/4	23.0	6.75	14.97	11.24	7.26	4.00	1.49	1.29	0.68
3	2 11/16	1/4	6.7	1.97	2.87	2.81	1.92	1.10	1.21	1.19	0.55
3 1/16	2 3/4	5/16	8.5	2.48	3.64	3.64	2.38	1.40	1.21	1.21	0.56
3	2 11/16	3/8	9.8	2.86	3.85	3.92	2.57	1.57	1.16	1.17	0.54
3 1/16	2 3/4	7/16	11.5	3.36	4.57	4.75	2.98	1.88	1.17	1.19	0.55
3	2 11/16	1/2	12.6	3.69	4.59	4.85	3.06	1.99	1.12	1.15	0.53
3 1/16	2 3/4	9/16	14.3	4.18	5.26	5.70	3.43	2.31	1.12	1.17	0.54

Properties of Carnegie Unequal Angles; Minimum, Intermediate, and Maximum Thicknesses and Weights.

Size, In.	Thickness, Inches.	Weight per Foot, Pounds.	Area of Section, Square Inches.	Moment of Inertia.— <i>I</i> .		Section Modulus.— <i>S</i> .		Radius of Gyration.— <i>r</i> .		
				Neutral Axis Parallel to Long Flange.	Neutral Axis Parallel to Short Flange.	Neutral Axis Parallel to Long Flange.	Neutral Axis Parallel to Short Flange.	Neutral Axis Parallel to Long Flange.	Neutral Axis Parallel to Short Flange.	Least Radius, Axis Diagonal.
8 × 6	1	44.2	13.00	38.8	80.8	8.9	15.1	1.73	2.49	1.28
	3/4	33.8	9.94	30.7	63.4	6.9	11.7	1.76	2.53	1.29
	7/16	20.2	5.93	19.3	39.2	4.2	7.1	1.80	2.57	1.30
8 × 3 1/2	1	35.7	10.50	7.8	66.2	3.0	13.7	0.86	2.51	0.73
	3/4	27.5	8.06	6.3	52.3	2.3	10.6	0.88	2.55	0.73
	7/16	16.5	4.84	4.1	32.5	1.5	6.4	0.92	2.59	0.74
7 × 3 1/2	1	32.3	9.50	7.5	45.4	3.0	10.6	0.89	2.19	0.74
	11/16	23.0	6.75	5.7	33.5	2.1	7.6	0.92	2.23	0.74
	3/8	13.0	3.80	3.5	19.6	1.3	4.3	0.96	2.27	0.76
6 × 4	1	30.6	9.00	10.8	30.8	3.8	8.0	1.09	1.85	0.85
	11/16	21.8	6.40	8.1	22.8	2.8	5.8	1.13	1.89	0.86
	3/8	12.3	3.61	4.9	13.5	1.6	3.3	1.17	1.93	0.88
6 × 3 1/2	1	28.9	8.50	7.2	29.2	2.9	7.8	0.92	1.85	0.74
	11/16	20.6	6.06	5.5	21.7	2.1	5.6	0.95	1.89	0.75
	5/16	9.8	2.87	2.9	10.9	1.0	2.7	1.00	1.95	0.77
5 × 4	7/8	24.2	7.11	9.2	16.4	3.3	5.0	1.14	1.52	0.84
	5/8	17.8	5.23	7.1	12.6	2.5	3.7	1.17	1.55	0.84
	3/8	11.0	3.23	4.7	8.1	1.6	2.3	1.20	1.59	0.86
5 × 3 1/2	7/8	22.7	6.67	6.2	15.7	2.5	4.9	0.96	1.53	0.75
	5/8	16.8	4.92	4.8	12.0	1.9	3.7	0.99	1.56	0.75
	5/16	8.7	2.56	2.7	6.6	1.0	1.9	1.03	1.61	0.76
5 × 3	13/16	19.9	5.84	3.7	14.0	1.7	4.5	0.80	1.55	0.64
	9/16	14.3	4.18	2.8	10.4	1.3	3.2	0.82	1.58	0.65
	5/16	8.2	2.40	1.8	6.3	0.75	1.9	0.85	1.61	0.66
4 1/2 × 3	13/16	18.5	5.43	3.6	10.3	1.7	3.6	0.81	1.38	0.64
	9/16	13.3	3.90	2.8	7.8	1.3	2.6	0.85	1.41	0.64
	5/16	7.7	2.25	1.7	4.7	0.75	1.5	0.87	1.44	0.66
4 × 3 1/2	13/16	18.5	5.43	5.5	7.8	2.3	2.9	1.01	1.19	0.72
	9/16	13.3	3.90	4.2	5.9	1.7	2.1	1.03	1.23	0.72
	5/16	7.7	2.25	2.6	3.6	1.0	1.3	1.07	1.26	0.73
4 × 3	13/16	17.1	5.03	3.5	7.3	1.7	2.9	0.83	1.21	0.64
	9/16	12.4	3.62	2.7	5.6	1.2	2.1	0.86	1.24	0.64
	1/4	5.8	1.69	1.4	2.8	0.60	1.0	0.89	1.28	0.65
3 1/2 × 3	13/16	15.8	4.62	3.3	5.0	1.7	2.2	0.85	1.04	0.62
	9/16	11.4	3.34	2.5	3.8	1.2	1.6	0.87	1.07	0.62
	1/4	5.4	1.56	1.3	1.9	0.58	0.78	0.91	1.11	0.63
3 1/2 × 2 1/2	11/16	12.5	3.65	1.7	4.1	0.99	1.9	0.69	1.06	0.53
	1/2	9.4	2.75	1.4	3.2	0.76	1.4	0.70	1.09	0.53
	1/4	4.9	1.44	0.78	1.8	0.41	0.75	0.74	1.12	0.54
3 × 2 1/2	9/16	9.5	2.78	1.4	2.3	0.82	1.2	0.72	0.91	0.52
	7/16	7.6	2.21	1.2	1.9	0.66	0.93	0.73	0.92	0.52
	1/4	4.5	1.31	0.74	1.2	0.40	0.56	0.75	0.95	0.53
3 × 2	1/2	7.7	2.25	0.67	1.9	0.47	1.0	0.55	0.92	0.43
	3/8	5.9	1.73	0.54	1.5	0.37	0.78	0.56	0.94	0.43
	1/4	4.1	1.19	0.39	1.1	0.25	0.54	0.57	0.95	0.43
2 1/2 × 2	1/2	6.8	2.00	0.64	1.1	0.46	0.70	0.56	0.75	0.42
	5/16	4.5	1.31	0.45	0.79	0.31	0.47	0.58	0.78	0.42
	1/8	1.86	0.55	0.20	0.35	0.13	0.20	0.61	0.89	0.43
2 1/2 × 1 1/2	5/16	3.92	1.15	0.19	0.71	0.17	0.44	0.41	0.79	0.32
	3/16	2.44	0.72	0.13	0.46	0.11	0.28	0.42	0.80	0.33
	1/2	5.6	1.63	0.26	0.75	0.26	0.54	0.40	0.68	0.32
2 1/4 × 1 1/2	3/16	2.28	0.67	0.12	0.34	0.11	0.23	0.43	0.72	0.33

(Table continued on next page.)

Properties of Carnegie Unequal Angles.—Continued.

Size, In.	Thickness, Inches.	Weight per Foot, Pounds.	Area of Section, Square Inches.	Moment of Inertia.—I.		Section Modulus.—S.		Radius of Gyration.—r.		
				Neutral Axis Parallel to Long Flange.	Neutral Axis Parallel to Short Flange.	Neutral Axis Parallel to Long Flange.	Neutral Axis Parallel to Short Flange.	Neutral Axis Parallel to Long Flange.	Neutral Axis Parallel to Short Flange.	Least Radius, Axis Diagonal.
2 × 1 1/2	3/8	3.99	1.17	0.21	0.43	0.20	0.34	0.42	0.61	0.32
	1/8	1.44	0.42	0.09	0.17	0.08	0.13	0.45	0.64	0.33
2 × 1 1/4	1/4	2.55	0.75	0.09	0.30	0.10	0.23	0.34	0.63	0.27
	3/16	1.96	0.57	0.07	0.23	0.08	0.18	0.35	0.64	0.27
1 3/4 × 1 1/4	1/4	2.34	0.69	0.09	0.20	0.10	0.18	0.35	0.54	0.27
	1/8	1.23	0.36	0.05	0.11	0.05	0.09	0.37	0.56	0.27
1 1/2 × 1 1/4	5/16	2.59	0.76	0.10	0.16	0.11	0.16	0.35	0.45	0.26
	3/16	1.64	0.48	0.07	0.19	0.07	0.10	0.37	0.46	0.26

Maximum and minimum sizes only are given for angles less than 2 1/2 × 2 in.

Safe Loads, in Thousands of Pounds, for Carnegie Unequal Angles Used as Beams. Minimum, Intermediate, and Maximum Thickness and Weights.

Size of Angle, Inches.	Neutral Axis Parallel to Shorter Leg.			Neutral Axis Parallel to Longer Leg.		
	Safe Load, 1 Foot Span.	Maximum Span, 360 × Deflection.		Safe Load, 1 Foot Span.	Maximum Span, 360 × Deflection.	
		Safe Load.	Lgth., Feet.		Safe Load.	Lgth., Feet.
8 × 6 × 1	161.17	7.49	21.5	95.15	5.44	17.5
8 × 6 × 3/4	124.48	5.68	21.9	73.92	4.13	17.9
8 × 6 × 7/16	75.41	3.37	22.4	45.12	2.47	18.3
8 × 3 1/2 × 1	146.03	7.53	19.4	32.21	3.10	10.4
8 × 3 1/2 × 3/4	113.17	5.72	19.8	25.07	2.33	10.8
8 × 3 1/2 × 7/16	68.80	3.39	20.3	15.57	1.38	11.3
7 × 3 1/2 × 1	112.85	6.52	17.3	31.57	3.10	10.2
7 × 3 1/2 × 11/16	81.07	4.58	17.7	22.83	2.14	10.7
7 × 3 1/2 × 3/8	46.19	2.54	18.2	13.44	1.19	11.2
6 × 4 × 1	85.55	5.56	15.4	40.43	3.55	11.4
6 × 4 × 11/16	61.65	3.88	15.9	29.44	2.47	11.9
6 × 4 × 3/8	35.41	2.16	16.4	17.07	1.39	12.3
6 × 3 1/2 × 1	83.52	5.57	15.0	30.93	3.09	10.0
6 × 3 1/2 × 11/16	60.27	3.89	15.5	22.51	2.14	10.5
6 × 3 1/2 × 5/16	29.23	1.83	16.0	11.09	1.00	11.1
5 × 4 × 7/8	53.23	4.00	13.3	35.31	3.15	11.2
5 × 4 × 5/8	39.79	2.92	13.6	26.45	2.28	11.6
5 × 4 × 3/8	24.96	1.78	14.0	16.75	1.40	12.0
5 × 3 1/2 × 7/8	52.05	4.04	12.9	26.88	2.71	9.9
5 × 3 1/2 × 5/8	38.93	2.93	13.3	20.27	1.97	10.3
5 × 3 1/2 × 5/16	20.69	1.51	13.7	10.88	1.02	10.7

(Table continued on next page.)

Maximum bending stress, 16,000 lb. per sq. in. Safe loads for other spans are inversely proportional to the span in feet. Safe loads include the weight of the angle, which should be deducted to give net load which can be carried.



Safe Loads, in Thousands of Pounds, for Carnegie Unequal Angles Used as Beams.—Continued.

Size of Angle, Inches.	Neutral Axis Parallel to Shorter Leg.			Neutral Axis Parallel to Longer Leg.		
	Safe Load, 1 Foot Span.	Maximum Span, 360 × Deflection.		Safe Load 1 Foot Span.	Maximum Span, 360 × Deflection.	
		Safe Load.	Lgth., Feet.		Safe Load.	Lgth., Feet.
5 × 3 × 13/16	47.47	3.77	12.6	18.56	2.16	8.6
5 × 3 × 9/16	34.45	2.65	13.0	13.55	1.51	9.0
5 × 3 × 5/16	20.16	1.51	13.4	8.00	0.85	9.4
4 1/2 × 3 × 13/16	38.61	3.36	11.5	18.24	2.15	8.5
4 1/2 × 3 × 9/16	28.16	2.38	11.8	13.33	1.51	8.8
4 1/2 × 3 × 5/16	16.43	1.35	12.2	8.00	0.87	9.2
4 × 3 1/2 × 13/16	31.15	2.94	10.6	24.53	2.56	9.6
4 × 3 1/2 × 9/16	22.93	2.08	11.0	17.92	1.79	10.0
4 × 3 1/2 × 5/16	13.44	1.18	11.4	10.67	1.03	10.4
4 × 3 × 13/16	30.61	2.97	10.3	17.92	2.15	8.3
4 × 3 × 9/16	22.40	2.09	10.7	13.12	1.51	8.7
4 × 3 × 1/4	10.67	0.96	11.1	6.40	0.70	9.1
3 1/2 × 3 × 13/16	23.47	2.57	9.1	17.60	2.17	8.1
3 1/2 × 3 × 9/16	17.17	1.81	9.5	12.91	1.52	8.5
3 1/2 × 3 × 1/4	8.32	0.84	9.9	6.19	0.70	8.9
3 1/2 × 2 1/2 × 11/16	19.73	2.19	9.0	10.56	1.51	7.0
3 1/2 × 2 1/2 × 1/2	15.04	1.63	9.2	8.11	1.13	7.2
3 1/2 × 2 1/2 × 1/4	8.00	0.83	9.6	4.37	0.58	7.6
3 × 2 1/2 × 9/16	12.27	1.53	8.0	8.75	1.25	7.0
3 × 2 1/2 × 7/16	9.92	1.22	8.1	7.04	0.99	7.1
3 × 2 1/2 × 1/4	5.97	0.71	8.4	4.27	0.58	7.4
3 × 2 × 1/2	10.67	1.39	7.7	5.01	0.88	5.7
3 × 2 × 3/8	8.32	1.05	7.9	3.95	0.67	5.9
3 × 2 × 1/4	5.76	0.71	8.1	2.77	0.46	6.1
2 1/2 × 2 × 1/2	7.47	1.15	6.5	4.91	0.89	5.5
2 1/2 × 2 × 5/16	5.01	0.74	6.8	3.31	0.57	5.8
2 1/2 × 2 × 1/8	2.13	0.30	7.1	1.49	0.23	6.1
*2 1/2 × 1 1/2 × 5/16	4.69	0.73	6.4	1.81	0.41	4.4
*2 1/2 × 1 1/2 × 3/16	2.99	0.45	6.6	1.17	0.25	4.6
*2 1/4 × 1 1/2 × 1/2	5.76	1.02	5.6	2.77	0.67	4.1
*2 1/4 × 1 1/2 × 3/16	2.45	0.40	6.0	1.17	0.25	4.6
*2 × 1 1/2 × 3/8	3.63	0.70	5.2	2.13	0.51	4.2
*2 × 1 1/2 × 1/8	1.39	0.24	5.6	0.80	0.17	4.6
*2 × 1 1/4 × 1/4	2.45	0.47	5.2	1.04	0.28	3.7
*2 × 1 1/4 × 3/16	1.92	0.36	5.3	0.80	0.21	3.8
*1 3/4 × 1 1/4 × 1/4	1.92	0.42	4.6	1.01	0.28	3.6
*1 3/4 × 1 1/4 × 1/8	1.00	0.21	4.8	0.56	0.15	3.8
*1 1/2 × 1 1/4 × 5/16	1.71	0.44	3.9	1.17	0.34	3.4
*1 1/2 × 1 1/4 × 3/16	1.07	0.26	4.1	0.78	0.22	3.6

Maximum bending stress, 16,000 lb. per sq. in. Safe loads for other spans are inversely proportional to the span in feet. Safe loads include the weight of the angle, which should be deducted to give net load which can be carried.

\* Only maximum and minimum sizes are given for angles smaller than 2 1/2 x 2 in.

Properties of Carnegie Angles with Equal Legs. Minimum, Intermediate and Maximum Thicknesses and Weights.

Dimensions.—Inches.	Thickness.—Inches.	Weight per foot.—Lb.	Area of Section.— Square Inches.	Distance of Center of Gravity from Back of Flange.—Inches.	Moment of Inertia, Neutral Axis through Center of Gravity Parallel to Flange.	Section Modulus, Neutral Axis through Center of Gravity Parallel to Flange.	Radius of Gyration, Neutral Axis through Center of Gravity Parallel to Flange.	Least Radius of Gyration, Neutral Axis through Center of Gravity at Angle of 45° to Flanges.
8 X 8	11/8	56.9	16.73	2.41	98.0	17.5	2.42	1.55
8 X 8	13/16	42.0	12.34	2.30	74.7	13.1	2.46	1.57
8 X 8	1/2	26.4	7.75	2.19	48.6	8.4	2.51	1.58
6 X 6	1	37.4	11.00	1.86	35.5	8.6	1.80	1.16
6 X 6	11/16	26.5	7.78	1.75	26.2	6.2	1.83	1.17
6 X 6	3/8	14.9	4.36	1.64	15.4	3.5	1.88	1.19
5 X 5	1	30.6	9.00	1.61	19.6	5.8	1.48	0.96
5 X 5	11/16	21.8	6.40	1.50	14.7	4.2	1.51	0.97
5 X 5	3/8	12.3	3.61	1.39	8.7	2.4	1.56	0.99
4 X 4	13/16	19.9	5.84	1.29	8.1	3.0	1.18	0.77
4 X 4	9/16	14.3	4.18	1.21	6.1	2.2	1.21	0.78
4 X 4	1/4	6.6	1.94	1.09	3.0	1.0	1.25	0.79
3 1/2 X 3 1/2	13/16	17.1	5.03	1.17	5.3	2.3	1.02	0.67
3 1/2 X 3 1/2	9/16	12.4	3.62	1.08	4.0	1.6	1.05	0.68
3 1/2 X 3 1/2	1/4	5.8	1.69	0.97	2.0	0.79	1.09	0.69
3 X 3	5/8	11.5	3.36	0.98	2.6	1.3	0.88	0.57
3 X 3	7/16	8.3	2.43	0.91	2.0	0.95	0.91	0.58
3 X 3	1/4	4.9	1.44	0.84	1.2	0.58	0.93	0.59
2 1/2 X 2 1/2	1/2	7.7	2.25	0.81	1.2	0.73	0.74	0.47
2 1/2 X 2 1/2	5/16	5.0	1.47	0.74	0.85	0.48	0.76	0.49
2 1/2 X 2 1/2	1/8	2.08	0.61	0.67	0.38	0.20	0.79	0.50
2 X 2	7/16	5.3	1.56	0.66	0.54	0.40	0.59	0.39
2 X 2	1/4	3.19	0.94	0.59	0.35	0.25	0.61	0.39
2 X 2	1/8	1.65	0.48	0.55	0.19	0.13	0.63	0.40
1 3/4 X 1 3/4	7/16	4.6	1.34	0.59	0.35	0.30	0.51	0.33
1 3/4 X 1 3/4	5/16	3.39	1.00	0.55	0.27	0.23	0.52	0.34
1 3/4 X 1 3/4	1/8	1.44	0.42	0.48	0.13	0.10	0.55	0.35
1 1/2 X 1 1/2	3/8	3.35	0.98	0.51	0.19	0.19	0.44	0.29
1 1/2 X 1 1/2	1/4	2.34	0.69	0.47	0.14	0.13	0.45	0.29
1 1/2 X 1 1/2	1/8	1.23	0.36	0.42	0.08	0.07	0.46	0.30
1 1/4 X 1 1/4	5/16	2.33	0.68	0.42	0.09	0.11	0.36	0.24
1 1/4 X 1 1/4	3/16	1.48	0.43	0.38	0.06	0.07	0.38	0.24
1 1/4 X 1 1/4	1/8	1.01	0.30	0.35	0.04	0.05	0.38	0.25
1 X 1	1/4	1.49	0.44	0.34	0.04	0.06	0.29	0.19
1 X 1	3/16	1.16	0.34	0.32	0.03	0.04	0.30	0.19
1 X 1	1/8	0.80	0.23	0.30	0.02	0.03	0.31	0.19

**Safe Loads, in Thousands of Pounds, Uniformly Distributed for Carnegie Equal Angles Used as Beams.**

(Maximum, Intermediate and Minimum Thicknesses and Weights.)

Size of Angle, Inches.	Safe Load One- Foot Span.	Maximum Span, 360 × De- flection.		Size of Angle, Inches.	Safe Load One- Foot Span.	Maximum Span, 360 × De- flection.			
		Safe Load	Lgth. Feet.			Safe Load	Lgth. Feet.		
8 × 8	× 1 1/8 13/16	186.99	8.31	22.5	2 1/2 × 2 1/2 × 1/2	7.79	1.15	6.8	
		139.84	6.08	23.0		5/16	5.12	0.72	7.1
		89.28	3.82	23.4		1/8	2.13	0.29	7.4
6 × 6	× 1 1/2 11/16	91.41	5.48	16.7	2 × 2 × 7/16	4.27	0.79	5.4	
		65.81	3.85	17.1		1/4	2.67	0.46	5.7
		37.65	2.14	17.6		1/8	1.39	0.24	5.8
5 × 5	× 1 3/8 11/16	61.87	4.55	13.6	1 3/4 × 1 3/4 × 7/16	3.20	0.68	4.7	
		44.80	3.18	14.1		5/16	2.45	0.51	4.8
		25.81	1.78	14.5		1/8	1.07	0.21	5.1
4 × 4	× 1 3/8 9/16	32.11	2.95	10.9	1 1/2 × 1 1/2 × 3/8	2.03	0.51	4.0	
		23.36	2.07	11.3		1/4	1.39	0.33	4.2
		11.20	0.96	11.7		1/8	0.77	0.17	4.4
3 1/2 × 3 1/2	× 1 3/8 9/16	24.00	2.55	9.4	1 1/4 × 1 1/4 × 5/16	1.17	0.36	3.3	
		17.60	1.81	9.7		3/16	0.76	0.22	3.5
		8.43	0.83	10.2		1/8	0.52	0.14	3.6
3 × 3	× 5/8 7/16	13.87	1.69	8.2	1 × 1 × 1/4	0.60	0.22	2.6	
		10.13	1.21	8.4		3/16	0.47	0.17	2.7
		6.19	0.71	8.7		1/8	0.33	0.12	2.8

Maximum bending stress, 16,000 lb. per sq. in. Safe loads for other spans are inversely proportional to the span in feet. Safe loads given include weight of angle which should be deducted to give net load that can be carried.

**Rivet Spacing for Structural Work.**—The following rules are condensed from those of the Cambria Steel Co. The minimum pitch of rivets should be at least three times the diameter, and in bridge work should not exceed 6 in., or 16 times the thickness of the thinnest outside plate. The minimum distance between edge of any piece and the center of the rivet is 1 1/4 in. for 3/4 and 7/8 in. rivets except in bars less than 2 1/2 in. wide. If possible this distance should be at least two rivet diameters for all sizes, and should not exceed eight times the thickness of the plate. The maximum pitch for flanges of girders and chords carrying floors is 4 in. Where plates are in compression, the maximum pitch in the lines of stress is sixteen times the plate thickness, and in the line at right angles to the line of stress, thirty-two times the plate thickness, except in the case of cover plates, top chords, and end posts, where the maximum pitch may be forty times the plate thickness. The minimum space between the rivet center and the adjacent leg when rivets are adjacent to the corners of angles is 1/2 the diameter of the head, plus 3/8 in. clearance. When there is a row of rivets in the adjacent leg, the 3/8 in. clearance should be measured from the rivet heads.

The table below, and those on page 322, give the standards adopted by the American Bridge Co. for rivet spacing in structural and bridge work:

**Gages for Angles, Inches.**

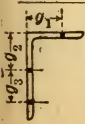

	8	7	6	5	4	3 1/2	3	2 1/2	2	1 3/4	1 1/2	1 1/4	1 3/4
g1	4 1/2	4	3 1/2	3	2 1/2	2	1 3/4	1 3/8	1 1/8	1	7/8	3/4	5/8
g2	3	2 1/2	2 1/2	2	.....	.....	.....	.....	.....	.....	.....	.....	.....
g3	3	3	2 1/4	1 3/4	.....	.....	.....	.....	.....	.....	.....	.....	.....
Max. Rivet	1 1/8	1	7/8	7/8	7/8	7/8	7/8	3/4	5/8	1/2	3/8	3/8	1/4 1/4

Minimum Spacing, Clearance and Stagger for Rivets.

Rivet Diam., In.	Minimum Spacing (x), In.	Minimum Clearance (k), In.	Distance c, Inches.															
			1 1/8	1 3/16	1 1/4	1 5/16	1 3/8	1 7/8	1 1/2	1 9/16	1 5/8	1 11/16	1 3/4	1 13/16	1 7/8	1 15/16	2 1/16	2 3/16
1/4	1 1/4	1 1/8	1 1/8	1 1/8	1 1/8	1 1/8	1 1/8	1 1/8	1 1/8	1 1/8	1 1/8	1 1/8	1 1/8	1 1/8	1 1/8	1 1/8	1 1/8	1 1/8
3/8	1 3/4	1 1/4	1 1/8	1 1/8	1 1/8	1 1/8	1 1/8	1 1/8	1 1/8	1 1/8	1 1/8	1 1/8	1 1/8	1 1/8	1 1/8	1 1/8	1 1/8	1 1/8
5/8	2 1/4	1 1/2	1 1/8	1 1/8	1 1/8	1 1/8	1 1/8	1 1/8	1 1/8	1 1/8	1 1/8	1 1/8	1 1/8	1 1/8	1 1/8	1 1/8	1 1/8	1 1/8
3/4	2 5/8	1 3/4	1 1/8	1 1/8	1 1/8	1 1/8	1 1/8	1 1/8	1 1/8	1 1/8	1 1/8	1 1/8	1 1/8	1 1/8	1 1/8	1 1/8	1 1/8	1 1/8
7/8	3	1 3/8	1 1/8	1 1/8	1 1/8	1 1/8	1 1/8	1 1/8	1 1/8	1 1/8	1 1/8	1 1/8	1 1/8	1 1/8	1 1/8	1 1/8	1 1/8	1 1/8
1 1/8	3 3/8	1 1/2	1 1/8	1 1/8	1 1/8	1 1/8	1 1/8	1 1/8	1 1/8	1 1/8	1 1/8	1 1/8	1 1/8	1 1/8	1 1/8	1 1/8	1 1/8	1 1/8

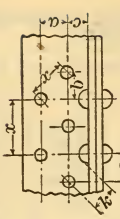

Center to Center Distance (x) of Staggered Rivets. For varying Values of a and b.

Rivet Diam., In.	Distance b, In.	Distance a, Inches.															
		7/8	1	1 1/8	1 1/4	1 3/8	1 1/2	1 5/8	1 3/4	1 7/8	2	2 1/8	2 1/4	2 3/8	2 1/2	2 5/8	2 3/4
1/8	1 1/8	1 1/8	1 1/8	1 1/8	1 1/8	1 1/8	1 1/8	1 1/8	1 1/8	1 1/8	1 1/8	1 1/8	1 1/8	1 1/8	1 1/8	1 1/8	1 1/8
1/4	1 1/4	1 1/8	1 1/8	1 1/8	1 1/8	1 1/8	1 1/8	1 1/8	1 1/8	1 1/8	1 1/8	1 1/8	1 1/8	1 1/8	1 1/8	1 1/8	1 1/8
3/8	1 3/8	1 1/8	1 1/8	1 1/8	1 1/8	1 1/8	1 1/8	1 1/8	1 1/8	1 1/8	1 1/8	1 1/8	1 1/8	1 1/8	1 1/8	1 1/8	1 1/8
1/2	1 1/2	1 1/8	1 1/8	1 1/8	1 1/8	1 1/8	1 1/8	1 1/8	1 1/8	1 1/8	1 1/8	1 1/8	1 1/8	1 1/8	1 1/8	1 1/8	1 1/8
5/8	1 5/8	1 1/8	1 1/8	1 1/8	1 1/8	1 1/8	1 1/8	1 1/8	1 1/8	1 1/8	1 1/8	1 1/8	1 1/8	1 1/8	1 1/8	1 1/8	1 1/8
3/4	1 3/4	1 1/8	1 1/8	1 1/8	1 1/8	1 1/8	1 1/8	1 1/8	1 1/8	1 1/8	1 1/8	1 1/8	1 1/8	1 1/8	1 1/8	1 1/8	1 1/8
7/8	1 7/8	1 1/8	1 1/8	1 1/8	1 1/8	1 1/8	1 1/8	1 1/8	1 1/8	1 1/8	1 1/8	1 1/8	1 1/8	1 1/8	1 1/8	1 1/8	1 1/8
1	1 7/8	1 1/8	1 1/8	1 1/8	1 1/8	1 1/8	1 1/8	1 1/8	1 1/8	1 1/8	1 1/8	1 1/8	1 1/8	1 1/8	1 1/8	1 1/8	1 1/8
1 1/8	1 1/2	1 1/8	1 1/8	1 1/8	1 1/8	1 1/8	1 1/8	1 1/8	1 1/8	1 1/8	1 1/8	1 1/8	1 1/8	1 1/8	1 1/8	1 1/8	1 1/8

Values below and to right of upper zigzag line are large enough for 3/4-inch rivets. Values below and to right of lower zigzag line are large enough for 7/8-inch rivets.



Notes on Tables of Channel and Plate and Angle Columns.

(Carnegie Steel Co.)

The tables on pages 324 to 330 give the safe loads in thousands of pounds which can be imposed on channel and plate and angle columns of the form and dimensions shown in the illustrations, which experience has shown to be desirable for ordinary bridges and buildings. They also give the moments of inertia and radii of gyration about both axes of symmetry, areas of section and weights per foot without allowances for rivet heads, or other details. The tables have been computed for the least radius of gyration in accordance with the American Bridge Co. formula for ratios of  $l/r$  up to 120,  $S = 19,000 - 100 l/r$ , in which  $S$  is the axial compressive strength, lb. per sq. in.,  $l$  is the length, in., and  $r$  is the radius of gyration, in. The maximum value of  $S$  is not to exceed 13,000. For ratios of  $l/r$  up to 120 and for greater ratios up to 200 the maximum values of  $S$  allowed are as follows:

$l/r$	$S$	$l/r$	$S$	$l/r$	$S$	$l/r$	$S$
60	13,000	100	9,000	140	6,000	180	4,000
70	12,000	110	8,000	150	5,500	190	3,500
80	11,000	120	7,000	160	5,000		
90	10,000	130	6,500	170	4,500		

The values given in the table may be compared with the values given by other formulæ by means of the comparative table on page 286. It is assumed in the tables that the loads are direct and equally distributed over the cross section of the column or balanced on opposite sides of it. In the case of unbalanced loads bending stresses are produced, and the column must be so proportioned that the combined fiber stresses do not exceed the allowable axial compression. (See page 296.)

The ratio  $l/r = 120$  should not be exceeded for main members under heavy stress. For secondary members such as wind bracing, under higher ratios, which, however, must not exceed 200, may be used.

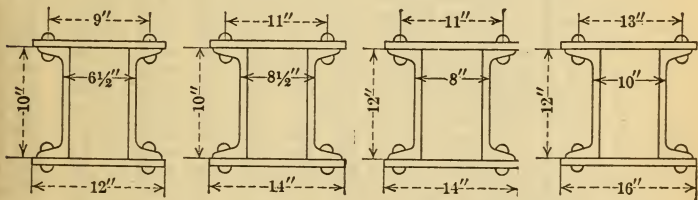

Fig. 83

Fig. 84

Fig. 85

Fig. 86

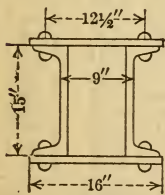

Fig. 87

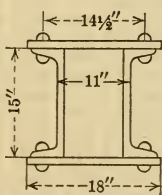

Fig. 88

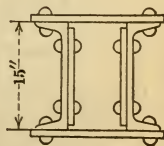

Fig. 89

DIMENSIONS OF CHANNEL COLUMNS.

(See tables, pages 324—327.)

Safe Loads on Carnegie 10-Inch Channel Columns in Thousands of Pounds. (See Figs. 83 and 84, page 323.)

Weight of Chan. lb. per ft.	Width of Side Plate, in.	Thickness of Side Plate, lb.	Effective Length of Column, Feet.									Radius of Gyr. Axis Parallel to Side Plate.	Radius of Gyr. Axis Perpend. to Side Plate.	Weight per Ft. lb.
			18	20	22	24	26	28	30	32	34			
15	12	Lat.	116	112	106	100	95	89	83	77	72	3.87	3.72	37.8
		5/16	213	203	192	181	170	159	148	137	126	4.50	3.60	55.5
		3/8	233	221	209	197	185	173	161	149	137	4.58	3.59	60.6
		7/16	252	239	226	213	200	187	174	161	148	4.65	3.58	65.7
		1/2	271	257	243	229	215	201	187	173	159	4.71	3.58	70.8
20	12	Lat.	152	144	136	128	120	112	104	96	88	3.66	3.55	47.8
		7/16	286	271	256	240	225	210	195	179	164	4.46	3.51	75.7
		1/2	305	289	272	256	240	223	207	191	174	4.53	3.50	80.8
		9/16	324	307	289	272	255	237	220	203	185	4.60	3.50	85.9
		5/8	343	325	307	288	270	252	233	215	196	4.66	3.50	91.0
25	12	Lat.	186	176	165	155	145	134	124	114	103	3.52	3.41	57.8
		9/16	359	339	319	300	280	260	241	221	201	4.45	3.44	95.9
		5/8	378	357	336	316	295	274	253	233	212	4.52	3.44	101.0
30	12	9/16	392	370	348	326	303	281	259	237	216	4.33	3.37	105.9
		5/8	411	388	364	341	318	295	271	248	227	4.39	3.37	111.0
35	12	9/16	424	400	375	350	325	301	276	251	232	4.22	3.30	115.9
		5/8	444	418	392	366	341	315	289	263	243	4.29	3.31	121.0
15	14	Lat.	116	114	109	103	98	92	87	81	75	3.87	4.70	39.3
		3/8	252	252	251	241	230	219	209	198	187	4.63	4.36	65.7
		7/16	275	275	273	261	250	238	226	214	203	4.70	4.33	71.7
		1/2	298	298	295	282	270	257	244	231	219	4.76	4.31	77.6
20	14	Lat.	153	146	139	131	123	115	108	100	92	3.66	4.53	49.4
		7/16	312	312	308	295	282	268	255	241	228	4.52	4.29	81.7
		1/2	335	335	330	316	301	287	272	258	243	4.59	4.27	87.6
		9/16	358	358	352	337	321	306	290	275	259	4.66	4.26	93.6
		5/8	380	380	374	357	341	324	308	291	274	4.72	4.24	99.5
25	14	Lat.	189	179	169	159	149	139	129	119	109	3.52	4.39	59.4
		9/16	396	396	388	371	353	336	319	301	284	4.52	4.22	103.6
		5/8	419	419	410	392	373	355	336	318	300	4.58	4.21	109.5
		11/16	441	441	432	412	393	373	354	335	315	4.64	4.20	115.5
		3/4	464	464	453	433	412	392	372	351	331	4.70	4.19	121.4
30	14	Lat.	224	211	199	187	174	162	149	137	125	3.42	4.28	69.4
		11/16	480	480	467	446	424	403	382	360	339	4.53	4.16	125.5
		3/4	502	502	488	466	444	421	399	377	354	4.59	4.15	131.4
		13/16	525	525	510	487	464	440	417	394	370	4.65	4.15	137.4
		7/8	548	548	532	508	483	459	434	410	385	4.70	4.14	143.3
		15/16	571	571	554	529	503	478	452	427	401	4.76	4.14	149.3
		1	593	593	575	549	522	496	469	443	416	4.81	4.13	155.2
35	14	15/16	609	609	588	561	533	506	479	451	424	4.66	4.10	159.3
		1	632	632	610	582	553	525	496	468	440	4.72	4.10	165.2
		11/16	654	654	632	603	573	544	514	485	455	4.77	4.10	171.2
		11/8	677	677	654	624	593	563	532	502	471	4.82	4.10	177.1
		13/16	700	700	675	644	612	581	549	517	486	4.87	4.09	183.1
		13/8	723	723	697	665	632	599	567	534	502	4.92	4.09	189.0

Safe loads enclosed between heavy lines are for ratios of  $l/r$  not over 60; between the dotted lines are for ratios of  $l/r$  not over 200; all other safe loads are for ratios of  $l/r$  up to 120. Allowable fiber stress 13,000 lb. for lengths of 60 radii or over. Weights do not include rivet heads or other details.

Safe Loads for Carnegie 12-Inch Channel Columns in Thousands of Pounds. (See Figs. 85 and 86, page 323.)

Weight of Channel, lb. per ft.	Width of Side Plate, In.	Thickness of Side Plate, in.	Effective Length of Column, Feet.									Radius of Gyration, Axis Parallel to Side Plate.	Radius of Gyration, Perpendicular to Side Plate.	Weight per Ft., lb.
			18	20	22	24	26	28	30	32	34			
20½	14	Lat.	157	157	157	152	146	139	133	126	120	4.61	4.50	50.4
		3/8	293	293	290	277	265	252	239	227	214	5.40	4.29	76.7
		7/16	316	316	312	298	284	271	257	243	230	5.48	4.27	82.7
		1/2	339	339	334	319	304	290	275	260	246	5.55	4.26	88.6
		9/16	362	362	355	339	324	308	292	277	261	5.62	4.24	94.6
		5/8	384	384	377	360	344	327	310	293	277	5.68	4.23	100.5
25	14	Lat.	191	191	190	182	174	166	158	150	142	4.43	4.36	59.4
		9/16	396	396	387	370	352	335	318	300	283	5.47	4.20	103.6
		5/8	419	419	409	390	372	354	335	317	298	5.53	4.19	109.5
		11/16	441	441	431	411	392	372	353	333	314	5.60	4.18	115.5
		3/4	464	464	453	432	412	391	371	350	330	5.66	4.18	121.4
		13/16	487	487	474	453	431	410	388	367	345	5.71	4.17	127.4
30	14	Lat.	229	229	225	215	205	195	185	175	165	4.28	4.23	69.4
		3/4	502	502	487	465	442	420	397	375	352	5.52	4.13	131.4
		13/16	525	525	509	486	462	439	415	392	368	5.58	4.13	137.4
		7/8	548	548	531	506	482	457	432	408	383	5.64	4.12	143.3
		15/16	571	571	553	527	502	476	450	425	399	5.70	4.12	149.3
		1	593	593	575	548	522	495	468	442	415	5.75	4.12	155.2
35	14	Lat.	268	268	259	248	236	224	212	200	188	4.17	4.13	79.4
		15/16	609	609	587	559	532	504	477	449	421	5.58	4.08	159.3
		1	632	632	609	580	552	523	494	466	437	5.64	4.08	165.2
		1 1/16	654	654	631	601	571	542	512	483	453	5.69	4.08	171.2
		1 1/8	677	677	653	622	591	561	530	499	469	5.74	4.08	177.1
		1 3/16	700	700	674	642	610	578	547	515	483	5.80	4.07	183.1
		1 1/4	723	723	695	663	630	597	564	532	499	5.85	4.07	189.0
		1 5/16	745	745	717	684	650	616	582	548	515	5.89	4.07	195.0
		1 3/8	768	768	739	704	670	635	600	565	530	5.94	4.07	200.9
		1 7/16	791	791	761	725	689	654	618	582	546	5.99	4.07	206.9
		1 1/2	814	814	783	746	709	672	635	599	562	6.04	4.07	212.8
		30	16	15/16	619	619	619	619	599	575	552	528	504	5.76
1	645			645	645	645	623	599	574	549	525	5.81	4.84	168.8
1 1/16	671			671	671	671	648	622	596	571	545	5.87	4.83	175.6
1 1/8	697			697	697	697	673	646	619	593	566	5.92	4.83	182.4
1 3/16	723			723	723	723	697	669	642	614	586	5.97	4.82	189.2
1 1/4	749			749	749	749	721	693	664	635	606	6.01	4.81	196.0
35	16	1 3/16	762	762	762	762	732	703	674	644	615	5.87	4.80	199.2
		1 1/4	788	788	788	787	756	726	696	665	635	5.91	4.79	206.0
		1 5/16	814	814	814	813	781	750	719	687	656	5.96	4.79	212.8
		1 3/8	840	840	840	838	805	773	741	708	676	6.01	4.78	219.6
		1 7/16	866	866	866	864	830	797	764	730	697	6.06	4.78	226.4
		1 1/2	892	892	892	889	854	820	785	751	716	6.10	4.77	233.2
		1 9/16	918	918	918	915	879	844	808	773	737	6.15	4.77	240.0
		1 5/8	944	944	944	940	903	867	830	794	757	6.19	4.76	246.8
		111/16	970	970	970	966	928	891	853	815	778	6.24	4.76	253.6
		1 3/4	996	996	996	992	953	914	876	837	799	6.28	4.76	260.4
		113/16	1022	1022	1022	1017	977	937	897	858	818	6.32	4.75	267.2
		1 7/8	1048	1048	1048	1042	1002	961	920	880	839	6.36	4.75	274.0
115/16	1074	1074	1074	1068	1027	985	943	901	860	6.41	4.75	280.8		
2	1100	1100	1100	1093	1050	1007	965	922	879	6.45	4.74	287.6		

Safe loads enclosed between heavy lines are for ratios of  $l/r$  not over 60; all others are for ratios  $l/r$  not over 120. Allowable fiber stress 13,000 lb. for lengths of 60 radii or over. Weights do not include rivet head or other details.



Safe Loads on 15-Inch Carnegie Channel Columns in Thousands of Pounds.\* (See Figs. 87 and 88, page 323.)

Wght of Chan., lb. per ft.	Width of Side Plate, in.	Thickness of Side Plate, in.	Effective Length of Column, Feet.										Radius of Gyration, Axis Parallel to Side Plate.	Radius of Gyration, Axis Perpendicular to Side Plate.	Weight per Ft., lb.
			18	20	22	24	26	28	30	32	34				
			Lat.												
33	16	Lat.	257	257	257	257	252	243	233	224	214	5.62	4.98	80.2	
		3/8	413	413	413	413	400	384	368	352	337	6.48	4.85	106.8	
		7/16	439	439	439	439	424	407	390	373	357	6.57	4.83	113.6	
		1/2	465	465	465	465	448	431	413	395	377	6.66	4.82	120.4	
		9/16	491	491	491	491	473	454	435	416	398	6.74	4.81	127.2	
		5/8	517	517	517	517	498	478	458	438	418	6.81	4.80	134.0	
35	16	Lat.	268	268	268	268	261	251	241	231	221	5.58	4.95	84.2	
		5/8	528	528	528	527	507	486	466	446	425	6.77	4.79	138.0	
		11/16	554	554	554	552	531	510	488	467	446	6.84	4.78	144.8	
		3/4	580	580	580	578	555	533	511	488	466	6.91	4.77	151.6	
		13/16	606	606	606	604	580	557	533	510	487	6.98	4.77	158.4	
		7/8	632	632	632	629	605	580	556	531	507	7.04	4.76	165.2	
40	16	Lat.	306	306	306	306	295	284	272	260	249	5.43	4.84	92.1	
		13/16	644	644	644	639	614	589	564	539	514	6.85	4.73	168.4	
		7/8	670	670	670	665	638	612	586	560	534	6.91	4.72	175.2	
		15/16	696	696	696	690	663	636	609	581	554	6.97	4.72	182.0	
		1	722	722	722	715	687	659	631	602	574	7.03	4.71	188.8	
		1 1/16	748	748	748	741	712	683	653	624	595	7.09	4.71	195.6	
45	16	1 1/8	774	774	774	767	737	706	676	646	615	7.15	4.71	202.4	
		Lat.	344	344	344	343	329	316	302	289	276	5.32	4.75	102.2	
		1 1/16	786	786	786	777	746	715	684	653	622	6.98	4.68	205.6	
		1 1/8	812	812	812	802	770	738	705	673	641	7.04	4.67	212.4	
		1 3/16	838	838	838	827	794	761	728	695	662	7.09	4.67	219.2	
		1 1/4	864	854	864	853	819	785	751	716	682	7.15	4.67	226.0	
33	18	1 5/16	890	890	890	879	844	808	773	738	703	7.20	4.67	232.8	
		1 3/8	916	916	916	904	868	832	796	760	723	7.25	4.67	239.6	
		1 7/16	942	942	942	930	893	856	818	781	744	7.30	4.67	246.4	
		1 1/2	968	968	968	956	918	879	841	803	764	7.35	4.67	253.2	
		3/8	433	433	433	433	433	421	407	393	379	6.54	5.67	111.9	
		7/16	462	462	462	462	462	462	449	433	418	6.63	5.64	119.6	
35	18	1/2	491	491	491	491	491	491	476	459	443	6.72	5.61	127.2	
		9/16	521	521	521	521	521	520	503	486	469	6.80	5.59	134.9	
		5/8	550	550	550	550	550	549	530	512	494	6.87	5.57	142.5	
		5/8	560	560	560	560	560	558	540	521	502	6.84	5.56	146.5	
		11/16	589	589	589	589	589	586	567	547	527	6.91	5.54	154.2	
		3/4	619	619	619	619	619	615	594	574	553	6.98	5.53	161.8	
40	18	13/16	648	648	648	648	648	643	621	599	578	7.04	5.51	169.5	
		7/8	677	677	677	677	677	671	649	626	603	7.10	5.50	177.1	
		13/16	686	686	686	686	686	680	657	634	610	6.92	5.49	179.5	
		7/8	715	715	715	715	715	708	684	660	636	6.98	5.48	187.1	
		15/16	745	745	745	745	745	736	711	685	660	7.04	5.46	194.8	
		1	774	774	774	774	774	764	738	712	685	7.10	5.45	202.4	
33	18	1 1/16	803	803	803	803	803	793	766	738	711	7.16	5.45	210.1	
		1 1/8	832	832	832	832	832	821	793	764	736	7.21	5.44	217.7	

\* Table continued on next page. See note at foot of page.



**Safe Loads on 15-Inch Carnegie Channel Columns in Thousands of Pounds.\*** (See Figs. 87 and 88, page 323.)

W'ght of Chan., lb. per ft.	Width of Side Plate, in.	Thickness of Side Plate, in.	Effective Length of Column, Feet.								Radius of Gyration, Axis Parallel to Side Plate.	Radius of Gyration, Axis Perpendicular to Side Plate.	Weight per Ft., lb.	
			18	20	22	24	26	28	30	32				34
45	18	1 1/16	841	841	841	841	841	829	800	771	743	7.05	5.42	220.1
		1 1/8	871	871	871	871	871	857	828	798	768	7.11	5.42	227.7
		1 3/16	900	900	900	900	900	885	855	824	793	7.17	5.41	235.4
		1 1/4	929	929	929	929	929	913	882	850	818	7.22	5.40	243.0
		1 5/16	958	958	958	958	958	942	909	877	844	7.27	5.40	250.0
		1 3/8	988	988	988	988	988	970	936	902	868	7.32	5.39	258.3
		1 7/16	1017	1017	1017	1017	1017	998	963	928	893	7.37	5.38	266.0
		1 1/2	1046	1046	1046	1046	1046	1026	991	955	919	7.42	5.38	273.6
		1 9/16	1075	1075	1075	1075	1075	1054	1017	980	943	7.47	5.37	281.3
		1 5/8	1105	1105	1105	1105	1105	1083	1045	1007	969	7.52	5.37	288.9
		1 11/16	1134	1134	1134	1134	1134	1112	1073	1034	995	7.57	5.37	296.6
		1 3/4	1163	1163	1163	1163	1163	1139	1099	1059	1019	7.61	5.36	304.2
		1 7/8	1222	1222	1222	1222	1222	1195	1153	1111	1069	7.70	5.35	319.5
		2	1280	1280	1280	1280	1280	1253	1208	1164	1120	7.79	5.35	334.8

**Safe Loads on 15-Inch Carnegie Channel Columns with Flange Plates in Thousands of Pounds.\*** (See Fig. 89, page 323.)

Weight of Chan., lb. per ft.	Width of Side Plate, in.	Thickness of Side Plate, in.	Width of Web Plate, in.	Thickness of Web Plate, in.	Effective Length of Column, Feet.								Radius of Gyration, Axis Parallel to Side Plate.	Radius of Gyration, Axis Perpendicular to Side Plate.	Weight per Ft., lb.		
					18	20	22	24	26	28	30	32				34	
35	18	2	14	3/8	1340	1340	1340	1340	1340	1307	1261	1214	1168	7.65	5.32	350.5	
				9/16	1408	1408	1408	1408	1408	1369	1320	1270	1221	7.52	5.28	368.4	
45	20	2	14	9/16	1485	1485	1485	1485	1485	1439	1387	1335	1283	7.39	5.25	388.4	
				5/8	1547	1547	1547	1547	1547	1547	1543	1495	1447	7.33	5.97	404.5	
				5/8	1612	1612	1612	1612	1612	1612	1607	1557	1507	7.43	5.96	421.5	
				5/8	1677	1677	1677	1677	1677	1677	1670	1618	1566	7.52	5.95	438.5	
				5/8	1742	1742	1742	1742	1742	1742	1735	1681	1627	7.61	5.95	455.5	
				5/8	1807	1807	1807	1807	1807	1807	1807	1798	1742	1686	7.70	5.94	472.5
				5/8	1872	1872	1872	1872	1872	1872	1863	1805	1747	1686	7.79	5.94	489.5
				5/8	1937	1937	1937	1937	1937	1937	1926	1866	1806	1747	7.88	5.93	506.5
				5/8	2002	2002	2002	2002	2002	2002	2002	1991	1929	1866	7.97	5.93	523.5
				5/8	2067	2067	2067	2067	2067	2067	2054	1989	1925	1866	8.05	5.92	540.5
				5/8	2132	2132	2132	2132	2132	2132	2118	2052	1985	1925	8.13	5.92	557.5

\*Safe load values enclosed within the heavy lines are for ratios of  $l/r$  not over 60; all others are for ratios of  $l/r$  not over 120. Allowable fiber stress per sq. in., 13,000 lb. for lengths of 60 radii or over. Weights do not include rivet heads or other details.



Safe Loads on Carnegie Plate and Angle Columns in Thousands of Pounds.—Continued.

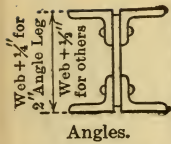

Angles.			Web Plate.		Effective Length in Feet.										Radius of Gyration, Axis Perpendicular to Web Plate.	Radius of Gyration, Axis Parallel to Web Plate.	Weight, Pounds per Foot.
			Width.	Thick-ness.	8	10	12	14	16	18	20	22	24	26			
4	×3	× 3/8	12	3/8	187	167	145	124	102	91	80	69	58	48	4.99	1.61	49.3
5	×3	1 1/2 × 3/8			217	217	201	181	162	142	123	110	100	91	5.02	2.06	56.9
5	×3	1 1/2 × 7/16			242	242	226	205	184	162	141	125	114	104	5.05	2.10	63.3
5	×3	1 1/2 × 1/2			266	266	252	229	206	184	161	141	129	118	5.07	2.15	69.7
6	×4	× 7/16			276	276	276	264	244	224	204	184	164	147	5.06	2.56	72.5
6	×4	× 1/2			305	305	305	295	274	252	230	209	187	166	5.07	2.61	80.1
6	×4	× 1/2	325	325	325	312	288	265	242	218	195	173	4.99	2.57	85.2		
6	×4	× 9/16	354	354	354	342	317	292	267	242	217	192	5.01	2.61	92.8		
6	×4	× 5/8	383	383	385	373	346	319	293	266	239	213	5.02	2.65	100.4		
6	×4	× 11/16	411	411	411	403	375	347	318	290	262	234	5.01	2.69	107.6		
6	×4	× 3/4	439	439	439	433	403	373	344	314	284	254	5.01	2.72	114.8		
6	×4	× 3/4	12	5/8	458	458	458	451	419	388	357	325	294	262	4.96	2.70	119.9
6	×4	× 3/4	12	3/4	478	478	478	469	436	403	370	338	305	272	4.91	2.69	125.0

Safe loads enclosed within dotted lines are for ratios of  $l/r$  of not over 60. Those enclosed within heavy lines are for ratios of  $l/r$  not over 200. All others are for ratios of  $l/r$  up to 120. Allowable fiber stress 13,000 lb. per sq. in. for lengths of 60 radii or less. Each column consists of four angles and one web plate. Weights given do not include rivet heads or other details.

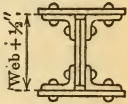

Safe Loads on Carnegie Plate and Angle Columns with Side Plates in Thousands of Pounds.

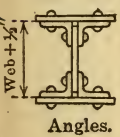

Angles.			Web Plate.		Side Plates.		Effective Length in Feet.										Radius of Gyration, Axis Perpendicular to Web Plate.	Radius of Gyration, Axis Parallel to Web Plate.	Weight, Pounds per Foot.
			Width.	Thick-ness.	Width.	Thick-ness.	16	18	20	22	24	26	28	30					
6×4	× 3/8	12	3/8	14	3/8	379	357	334	312	289	267	244	222	5.58	3.14	100.2			
6×4	× 3/8				1/2	428	407	383	358	334	310	285	261	237	5.71	3.25	112.1		
6×4	× 7/16				1/2	458	434	407	381	355	329	303	277	251	5.68	3.23	120.1		
6×4	× 1/2				1/2	487	461	433	405	377	349	321	293	265	5.65	3.22	127.7		
6×4	× 1/2	12	1/2	14	1/2	506	476	447	417	388	358	329	299	5.58	3.18	132.8			
6×4	× 1/2				5/8	553	526	495	463	432	401	369	338	307	5.69	3.26	144.7		
6×4	× 9/16				5/8	582	553	520	487	454	421	388	354	320	5.67	3.25	152.3		
6×4	× 5/8				5/8	610	579	544	509	475	440	405	370	335	5.64	3.24	159.9		
6×4	× 5/8				5/8	630	594	558	522	486	450	413	377	341	5.59	3.21	165.0		
6×4	× 5/8				3/4	675	644	606	568	529	491	453	415	377	5.69	3.27	176.9		
6×4	× 5/8	12	5/8	14	7/8	721	694	654	614	574	534	494	454	5.79	3.33	188.8			
6×4	× 5/8				1	766	742	700	658	616	574	532	490	448	5.88	3.37	200.7		

Safe loads enclosed in dotted lines are for ratios of  $l/r$  not over 60. Those enclosed in heavy lines are for ratios of  $l/r$  not over 200. All others are for ratios of  $l/r$  up to 120. Allowable fiber stress, 13,000 lb. per sq. in. for length of 60 radii and under. Each column consists of four angles, two side plates, and one web plate except those marked \*, which have two web plates. Weights given do not include rivet heads and other details.

Table continued on next page.



Safe Loads on Carnegie Plate and Angle Columns with Side Plates in Thousands of Pounds. \*—Continued.

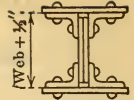

Angles.	Web Plate.		Side Plates.		Effective Length in Feet.									Radius of Gyration Axis Perpendicular to Web Plate.	Radius of Gyration Axis Parallel to Web Plate.	Weight, Pounds per Foot.		
	Width.	Thickness.	Width.	Thickness.	18	20	22	24	26	28	30	32						
6x4x 5/8	12	5/8	14	1 1/8	719	747	703	659	615	571	527	483	5.97	3.14	212.6			
6x4x 5/8				1 1/4	840	794	748	702	657	611	565	519	473	6.06	3.45	224.5		
6x4x 5/8				1 3/8	888	840	793	745	697	649	601	553	505	6.14	3.48	236.4		
6x4x 5/8				1 1/2	937	887	837	787	738	688	638	588	538	6.22	3.51	248.3		
6x4x 5/8				1 5/8	986	934	882	830	779	727	675	623	571	6.30	3.54	260.2		
6x4x 5/8				1 3/4	1034	980	926	872	818	764	710	657	603	6.38	3.56	272.1		
6x4x 5/8				1 7/8	1082	1026	970	914	858	802	746	690	634	6.46	3.58	284.0		
6x4x 5/8				2	1130	1072	1014	956	898	840	782	725	667	6.54	3.60	295.9		
6x4x 3/8	14	3/8	14	3/8	363	340	317	293	270	246	223	205	6.46	3.10	102.8			
6x4x 7/16				3/8	390	365	340	314	289	264	239	220	200	6.45	3.09	110.8		
6x4x 1/2				3/8	417	390	363	336	309	282	255	236	216	6.43	3.09	118.4		
6x4x 1/2				7/16	442	415	387	359	331	303	275	251	227	6.49	3.14	124.3		
6x4x 1/2	14	3/8	14	1/2	468	439	410	381	353	324	295	267	6.55	3.19	130.3			
6x4x 1/2				9/16	493	463	433	403	374	344	314	284	254	6.61	3.23	136.2		
6x4x 1/2	14	3/8	14	5/8	517	487	456	426	395	364	334	303	6.67	3.27	142.2			
6x4x 1/2				5/8	535	502	470	437	405	373	340	308	276	6.58	3.22	148.1		
6x4x 9/16	14	1/2	14	5/8	561	527	493	459	424	390	356	322	6.56	3.21	155.7			
6x4x 5/8				5/8	587	551	515	479	443	407	372	336	300	6.54	3.20	163.3		
6x4x 5/8				5/8	606	568	530	493	455	417	380	345	309	6.47	3.17	169.3		
6x4x 5/8	14	5/8	14	3/4	655	615	576	536	497	457	418	378	6.58	3.23	181.2			
6x4x 5/8				7/8	705	664	622	581	540	498	457	415	374	6.68	3.29	193.1		
6x4x 5/8				1	754	711	668	625	581	538	495	452	410	6.78	3.34	205.0		
6x4x 5/8				1 1/8	803	758	713	667	622	577	532	487	442	6.87	3.38	216.9		
6x4x 5/8				1 1/4	852	805	758	711	664	617	569	522	475	6.96	3.42	228.8		
6x4x 5/8				1 3/8	901	851	802	753	704	655	605	556	507	7.05	3.45	240.7		
6x4x 5/8				1 1/2	949	898	847	796	744	693	642	591	540	7.13	3.48	252.6		
6x4x 5/8				1 5/8	998	945	892	839	786	732	679	626	573	7.22	3.51	264.5		
6x4x 5/8	14	5/8	14	1 3/4	1046	991	935	880	825	770	715	659	7.30	3.53	276.4			
6x4x 5/8				1 7/8	1095	1038	981	924	867	810	753	696	639	7.38	3.56	288.3		
6x4x 5/8				2	1144	1084	1025	966	907	848	789	730	671	7.46	3.58	300.2		
6x4x 5/8				1 7/8	1198	1198	1146	1091	1036	981	926	871	816	7.45	4.02	313.8		
6x4x 5/8				2	1250	1250	1201	1144	1087	1030	973	916	859	7.53	4.05	327.4		
6x6x 5/8				16	2 1/8	16	2	1315	1308	1246	1185	1123	1062	1000	939	7.36	3.95	344.2
6x6x 5/8							2 1/8	1367	1364	1301	1237	1174	1111	1047	984	921	7.44	3.98
6x6x 5/8				16	2 1/4	16	2 1/4	1419	1419	1356	1290	1225	1160	1094	1029	7.53	4.01	371.4
6x6x 5/8	2 3/8	1471	1471				1409	1342	1274	1207	1139	1072	1005	7.61	4.03	385.0		
6x6x 5/8	2 1/2	1523	1523				1463	1393	1324	1254	1185	1115	1045	7.69	4.05	398.6		
6x6x 5/8	2 1/2	1592	1590				1516	1443	1369	1295	1222	1148	1074	7.57	3.99	416.4		
8x6x 5/8	16	2 1/2	16	2 1/2	1657	1657	1616	1543	1470	1397	1324	1251	7.54	4.18	433.6			
8x6x 5/8				2 3/8	1728	1728	1728	1695	1626	1557	1488	1419	1350	7.54	4.61	452.3		
8x6x 5/8				2 1/2	1787	1787	1787	1756	1685	1614	1543	1471	1400	7.62	4.63	467.6		
8x6x 5/8				2 5/8	1845	1845	1845	1818	1744	1671	1598	1525	1452	7.70	4.65	482.9		
8x6x 5/8	18	2 3/4	18	2 3/4	1904	1904	1904	1879	1804	1729	1653	1578	7.78	4.67	498.2			
8x6x 5/8				2 3/4	1949	1949	1949	1918	1841	1763	1686	1608	1531	7.71	4.64	510.1		
8x6x 5/8	14	5/8	20	2 3/4	2027	2027	2027	2027	2009	1935	1862	1789	7.70	5.10	530.5			
8x6x 5/8				2 3/4	2092	2092	2092	2092	2077	2002	1926	1851	1776	7.78	5.12	547.5		
8x6x 5/8				2 7/8	2157	2157	2157	2157	2146	2068	1991	1913	1835	7.86	5.14	564.5		
8x6x 5/8				3	2222	2222	2222	2222	2214	2135	2055	1976	1897	7.94	5.16	581.5		
8x6x 5/8				3 1/8	2287	2287	2287	2287	2283	2202	2120	2039	1958	8.01	5.18	598.5		

\*See note at foot of page 329.



**Bethlehem, Girder and I-Beams, and H-Columns.**—The tables of special and girder beams give the sections and weights usually rolled. Intermediate and heavier weights may be obtained by special arrangement. The table of H-columns gives only the minimum and maximum weights for each section number. Many intermediate weights are regularly made.

The coefficients of strength given in the tables are based on a maximum fiber stress of 16,000 lb. per sq. in., which is allowable for quiet-cent loads, as in buildings. For moving loads the fiber stress of 12,500 lb. per sq. in. should be used, and the coefficients reduced proportionately. For suddenly applied loads, as in railroad bridges, they should be still further reduced. For a fiber stress of 8000 lb. per sq. in. the coefficients would be one-half those given in the tables. The quotient obtained by dividing the coefficient given for the beam by the span in feet will give the uniformly distributed safe load in pounds, including the weight of the beam. If the load is concentrated at the middle of the span the safe load is one half the uniformly distributed load.

For further information see handbook of Structural Steel Shapes, Bethlehem Steel Co., South Bethlehem, Pa., 1911.

**Properties of Bethlehem Girder Beams.**

Depth of Beam, Inches.	Weight per Foot, Pounds.	Area of Section, Square Inches.	Thickness of Web, Inch.	Width of Flange, Inches.	Neutral Axis Perpendicular to Web at Center.			Coefficients of Strength for Fiber Stress of 16,000 Lb. per Sq. In. for Buildings.	Maximum Safe Shear on Web, Tons of 2000 Lb.	Neutral Axis Coincident with Center Line of Web.	
					Moment of Inertia. <i>I</i>	Radius of Gyration. <i>r</i>	Section Modulus. <i>S</i>			Moment of Inertia. <i>I'</i>	Radius of Gyration. <i>r'</i>
30	200.0	58.71	0.75	15.00	9150.6	12.48	610.0	6,507,100	94.65	630.2	3.28
30	180.0	53.00	.69	13.00	8194.5	12.43	546.3	5,827,200	82.60	433.3	2.86.
28	180.0	52.86	.69	14.35	7264.7	11.72	518.9	5,535,000	80.75	533.3	3.18
28	165.0	48.47	.66	12.50	6562.7	11.64	468.8	5,000,100	75.15	371.9	2.77
26	160.0	46.91	.63	13.60	5620.8	10.95	432.4	4,611,900	67.95	435.7	3.05
26	150.0	43.94	.63	12.00	5153.9	10.83	396.5	4,228,800	67.95	314.6	2.68
24	140.0	41.16	.60	13.00	4201.4	10.10	350.1	3,734,600	60.85	346.9	2.90
24	120.0	35.38	.53	12.00	3607.3	10.10	300.6	3,206,500	49.25	249.4	2.66
20	140.0	41.19	.64	12.50	2934.7	8.44	293.5	3,130,300	62.10	348.9	2.91
20	112.0	32.81	.55	12.00	2342.1	8.45	234.2	2,498,300	49.25	239.3	2.70
18	92.0	27.12	.48	11.50	1591.4	7.66	176.8	1,886,100	38.05	182.6	2.59
15	140.0	41.27	.80	11.75	1592.7	6.21	212.4	2,265,200	67.10	331.0	2.83
15	104.0	30.50	.60	11.25	1220.1	6.32	162.7	1,735,300	47.15	213.0	2.64
15	73.0	21.49	.43	10.50	883.4	6.41	117.8	1,256,600	29.60	123.2	2.39
12	70.0	20.58	.46	10.00	538.8	5.12	89.8	957,800	28.60	114.7	2.36
12	55.0	16.18	.37	9.75	432.0	5.17	72.0	768,000	21.15	81.1	2.24
10	44.0	12.95	.31	9.00	244.2	4.34	48.8	521,000	14.90	57.3	2.10
9	38.0	11.22	.30	8.50	170.9	3.90	38.0	405,000	13.35	44.1	1.98
8	32.5	9.54	.29	8.00	114.4	3.46	28.6	305,100	11.80	32.9	1.86

*W* = Safe load in pounds uniformly distributed, including weight of beam.  
*L* = Span in feet. *M* = Moment of forces in foot-pounds. *f* = fiber stress.  
 $W = C/L$ ;  $M = C/8$ ;  $C = WL = 8M = \frac{2}{3}fS$ .

## Properties of Bethlehem I-Beams.

Depth of Beam, Inches.	Weight per Foot, Pounds.	Area of Section Square Inches.	Thickness of Web, Inch.	Width of Flange, Inches.	Neutral Axis Perpendicular to Web at Center.			Coefficients of Strength for Fiber Stress of 16,000 Lb. per Sq. In. for Buildings.	Maximum Safe Shear on Web, Tons of 2000 Lb.	Neutral Axis Coin- cident with Center Line of Web.	
					Moment of Inertia. <i>I</i>	Radius of Gy- ration. <i>r</i>	Section Modu- lus. <i>S</i>			Moment of Inertia. <i>I'</i>	Radius of Gy- ration. <i>r'</i>
30	120.0	35.30	.540	10.500	5239.6	12.18	349.3	3,726,000	51.90	165.0	2.16
28	105.0	30.88	.500	10.000	4014.1	11.40	286.7	3,058,400	44.50	131.5	2.06
26	90.0	26.49	.460	9.500	2977.2	10.60	229.0	2,442,800	37.65	101.2	1.95
24	84.0	24.80	.460	9.250	2381.9	9.80	198.5	2,117,300	37.55	91.1	1.92
24	83.0	24.59	.520	9.130	2240.9	9.55	186.7	1,991,900	46.55	78.0	1.78
24	73.0	21.47	.390	9.000	2091.0	9.87	174.3	1,858,700	27.00	74.4	1.86
20	82.0	24.17	.570	8.890	1559.8	8.03	156.0	1,663,800	51.20	79.9	1.82
20	72.0	21.37	.430	8.750	1466.5	8.28	146.7	1,564,300	32.45	75.9	1.88
20	69.0	20.26	.520	8.145	1268.9	7.91	126.9	1,353,500	44.10	51.2	1.59
20	64.0	18.86	.450	8.075	1222.1	8.05	122.2	1,303,600	34.70	49.8	1.62
20	59.0	17.36	.375	8.000	1172.2	8.22	117.2	1,250,300	25.00	48.3	1.66
18	59.0	17.40	.495	7.675	883.3	7.12	98.1	1,046,900	39.00	39.1	1.50
18	54.0	15.87	.410	7.590	842.0	7.28	93.6	997,900	28.75	37.7	1.54
18	52.0	15.24	.375	7.555	825.0	7.36	91.7	977,700	24.60	37.1	1.56
18	48.5	14.25	.320	7.500	798.3	7.48	88.7	946,100	18.35	36.2	1.59
15	71.0	20.95	.520	7.500	796.2	6.16	106.2	1,132,400	38.95	61.3	1.71
15	64.0	18.81	.605	7.195	664.9	5.95	88.6	945,600	46.95	41.9	1.49
15	54.0	15.88	.410	7.000	610.0	6.20	81.3	867,600	27.40	38.3	1.55
15	45.0	13.52	.440	6.810	484.8	5.99	64.6	689,500	30.00	25.2	1.36
15	41.0	12.02	.340	6.710	456.7	6.16	60.9	649,400	19.95	24.0	1.41
15	38.0	11.27	.290	6.660	442.6	6.27	59.0	629,500	15.05	23.4	1.44
12	36.0	10.61	.310	6.300	269.2	5.04	44.9	478,600	16.10	21.3	1.42
12	32.0	9.44	.335	6.205	228.5	4.92	38.1	406,200	17.90	16.0	1.30
12	28.5	8.42	.250	6.120	216.2	5.07	36.0	384,400	11.10	15.3	1.35
10	28.5	8.34	.390	5.990	134.6	4.02	26.9	287,100	19.90	12.1	1.21
10	23.5	6.94	.250	5.850	122.9	4.21	24.6	262,200	10.50	11.2	1.27
9	24.0	7.04	.365	5.555	92.1	3.62	20.5	218,300	16.95	8.8	1.12
9	20.0	6.01	.250	5.440	85.1	3.76	18.9	201,800	10.05	8.2	1.17
8	19.5	5.78	.325	5.325	60.6	3.24	15.1	161,600	13.45	6.7	1.08
8	17.5	5.18	.250	5.250	57.4	3.33	14.3	153,000	9.45	6.4	1.11

$W$  = Safe load in pounds uniformly distributed, including weight of beam.

$L$  = Span in feet.  $M$  = Moment of forces in foot-pounds.  $f$  = fiber stress.

$C$  = Coefficients given in the table.

$W = C/L$ ;  $M = C/8$ ;  $C = WL = 8M = \frac{2}{3}fS$ .

Dimensions and Properties of Bethlehem Rolled Steel H-Columns.\*

Weight Lb. per Foot.	Dimensions, in Inches.					Area of Section, Square Inches.	Neutral Axis Perpen. to Web.			Neutral Axis on Center Line of Web.		
	Depth.	Mean Thick- ness of Flange.	Breadth of Flange.	Thickness of Web	Depth of Par- allel Por- tion of Web		Moment of Inertia.	Section Modulus.	Radius of Gyration.	Moment of Inertia.	Section Modulus.	Radius of Gyration.

14-Inch H-Columns

83.5	13 3/4	11/16	13.92	0.43	11.06	24.46	884.9	128.7	6.01	294.5	42.3	3.47
91.0	13 7/8	3/4	13.96	.47	11.06	26.76	976.8	140.8	6.04	325.4	46.6	3.49
99.0	14	13/16	14.00	.51	11.06	29.06	1070.6	153.0	6.07	356.9	51.0	3.50
162.0	15	1 5/16	14.31	.82	11.06	47.71	1894.0	252.5	6.30	626.1	87.5	3.62
170.5	15 1/8	1 3/8	14.35	.86	11.06	50.11	2007.0	265.4	6.33	662.3	92.3	3.64
227.5	16	1 13/16	14.62	1.13	11.06	66.98	2859.6	357.5	6.53	929.4	127.1	3.72
236.0	16 1/8	1 7/8	14.66	1.17	11.06	69.45	2991.5	371.0	6.56	970.0	132.3	3.74
287.5	16 7/8	2 1/4	14.90	1.41	11.06	84.50	3836.1	454.7	6.74	1226.7	164.7	3.81

12-Inch H-Columns

64.5	11 3/4	5/8	11.92	0.39	9.21	19.00	499.0	84.9	5.13	168.6	28.3	2.98
71.5	11 7/8	11/16	11.96	.43	9.21	20.96	556.6	93.7	5.15	188.2	31.5	3.00
78.0	12	3/4	12.00	.47	9.21	22.94	615.6	102.6	5.18	208.1	34.7	3.01
132.5	13	1 1/4	12.31	.78	9.21	38.97	1141.3	175.6	5.41	380.7	61.9	3.13
139.5	13 1/8	1 5/16	12.35	.82	9.21	41.03	1214.5	185.0	5.44	404.1	65.4	3.14
161.0	13 1/2	1 1/2	12.47	.94	9.21	47.28	1444.3	214.0	5.53	477.0	76.5	3.18

10-Inch H-Columns

49.0	9 7/8	9/16	9.97	0.36	7.67	14.37	263.5	53.4	4.28	89.1	17.9	2.49
54.0	10	5/8	10.00	.39	7.67	15.91	296.8	59.4	4.32	100.4	20.1	2.51
99.5	11	1 1/8	10.31	.70	7.67	29.32	607.0	110.4	4.55	201.7	39.1	2.62
105.5	11 1/8	1 3/16	10.35	.74	7.67	31.06	651.0	117.0	4.58	215.6	41.7	2.64
123.5	11 1/2	1 3/8	10.47	.86	7.67	36.32	790.4	137.5	4.67	259.3	49.5	2.67

8-Inch H-Columns

32.0	7 7/8	7/16	8.00	0.31	6.14	9.17	105.7	26.9	3.40	35.8	8.9	1.98
34.5	8	1/2	8.00	.31	6.14	10.17	121.5	30.4	3.46	41.1	10.3	2.01
71.5	9	1	8.32	.63	6.14	21.05	285.6	63.5	3.68	94.4	22.7	2.12
76.5	9 1/8	1 1/16	8.36	.67	6.14	22.46	309.5	67.8	3.71	101.9	24.4	2.13
90.5	9 1/2	1 1/4	8.47	.78	6.14	26.64	385.3	81.1	3.80	125.1	29.6	2.17

\* The tables are greatly condensed from the original. The depth of section regularly rolled in each size advances by 1/8 inch from the smallest to the largest section shown in each table. The increased depth of each section in a given size is obtained by adding metal to the flanges, the depth of web remaining constant in each size.



## TORSIONAL STRENGTH.

Let a horizontal shaft of diameter =  $d$  be fixed at one end, and at the other or free end, at a distance =  $l$  from the fixed end, let there be fixed a horizontal lever arm with a weight =  $P$  acting at a distance =  $a$  from the axis of the shaft so as to twist it; then  $Pa$  = moment of the applied force.

Resisting moment = twisting moment =  $SJ/c$ , in which  $S$  = unit shearing resistance,  $J$  = polar moment of inertia of the section with respect to the axis, and  $c$  = distance of the most remote fiber from the axis, in a cross-section. For a circle with diameter  $d$

$$J = 1/32 \pi d^4; \quad c = 1/2 d;$$

$$Pa = \frac{SJ}{c} = \frac{\pi d^3 S}{16} = \frac{d^3 S}{5.1} = 0.1963 d^3 S; \quad d = \sqrt[3]{\frac{5.1 Pa}{S}}.$$

For hollow shafts of external diameter  $d$  and internal diameter  $d_1$ ,

$$Pa = 0.1963 \frac{d^4 - d_1^4}{d} S; \quad d = \sqrt[3]{\frac{5.1 Pa}{\left(1 - \frac{d_1^4}{d^4}\right) S}}.$$

In solving the last equation the ratio  $d_1/d$  is first assumed.

For a rectangular bar in which  $b$  and  $d$  are the long and short sides of the rectangle,  $Pa = 0.2222 bd^3 S$ ; and for a square bar with side  $d$ ,  $Pa = 0.2222 d^3 S$ . (Merriman, "Mechanics of Materials," 10th ed.)

The above formulæ are based on the supposition that the shearing resistance at any point of the cross-section is proportional to its distance from the axis; but this is true only within the elastic limit. In materials capable of flow, while the particles near the axis are strained within the elastic limit those at some distance within the circumference may be strained nearly to the ultimate resistance, so that the total resistance is something greater than that calculated by the formulæ. For working strength, however, the formulæ may be used, with  $S$  taken at the safe working unit resistance.

The ultimate torsional shearing resistance  $S$  is about the same as the direct shearing resistance, and may be taken at 20,000 to 25,000 lbs. per square inch for cast iron, 45,000 lbs. for wrought iron, and 50,000 to 150,000 lbs. for steel, according to its carbon and temper. Large factors of safety should be taken, especially when the direction of stress is reversed, as in reversing engines, and when the torsional stress is combined with other stresses, as is usual in shafting. (See "Shafting.")

**Elastic Resistance to Torsion.**— Let  $l$  = length of bar being twisted,  $d$  = diameter,  $P$  = force applied at the extremity of a lever arm of length =  $a$ ,  $Pa$  = twisting moment,  $G$  = torsional modulus of elasticity,  $\theta$  = angle through which the free end of the shaft, is twisted, measured in arc of radius = 1.

For a cylindrical shaft,

$$Pa = \frac{\pi \theta G d^4}{32 l}; \quad \theta = \frac{32 Pal}{\pi d^4 G}; \quad G = \frac{32 Pal}{\theta \pi d^4}; \quad \frac{32}{\pi} = 10.186.$$

If  $\alpha$  = angle of torsion in degrees,

$$\theta = \frac{\alpha \pi}{180}; \quad \alpha = \frac{180 \theta}{\pi} = \frac{180 \times 32 Pal}{\pi^2 d^4 G} = \frac{583.6 Pal}{d^4 G}.$$

The value of  $G$  is given by different authorities as from  $1/3$  to  $2/5$  of  $E$ , the modulus of elasticity for tension. For steel it is generally taken as 12,000,000 lbs. per sq. in.



**COMBINED STRESSES.**

**Combined Tension and Flexure.** — Let  $A$  = the area of a bar subjected to both tension and flexure,  $P$  = tensile stress applied at the ends,  $P \div A$  = unit tensile stress,  $S$  = unit stress at the fiber on the tensile side most remote from the neutral axis, due to flexure alone, then maximum tensile unit stress =  $(P \div A) + S$ . A beam to resist combined tension and flexure should be designed so that  $(P \div A) + S$  shall not exceed the proper allowable working unit stress.

**Combined Compression and Flexure.** — If  $P + A$  = unit stress due to compression alone, and  $S$  = unit compressive stress at fiber most remote from neutral axis, due to flexure alone, then maximum compressive unit stress =  $(P \div A) + S$ .

**Combined Tension (or Compression) and Shear.** — If applied tension (or compression) unit stress =  $p$ , applied shearing unit stress =  $v$ , then from the combined action of the two forces

$$\text{Max. } S = \pm \sqrt{v^2 + 1/4p^2}, \text{ Maximum shearing unit stress;}$$

$$\text{Max. } t = 1/2 p + \sqrt{v^2 + 1/4p^2}, \text{ Maximum tensile (or compressive) unit stress.}$$

**Combined Flexure and Torsion.** — If  $S$  = greatest unit stress due to flexure alone, and  $S_s$  = greatest torsional shearing unit stress due to torsion alone, then for the combined stresses

$$\text{Max. tension or compression unit stress } t = 1/2 S + \sqrt{S_s^2 + 1/4S^2};$$

$$\text{Max. shear } s = \pm \sqrt{S_s^2 + 1/4S^2}.$$

Equivalent bending moment =  $1/2 M + 1/2 \sqrt{M^2 + T^2}$ , where  $M$  = bending moment and  $T$  = torsional moment.

Formula for diameter of a round shaft subjected to transverse load while transmitting a given horse-power (see also Shafts of Engines):

$$d^3 = \frac{16 M}{\pi t} + \frac{16}{t} \sqrt{\frac{M^2}{\pi^2} + \frac{402,500,000 H^2}{n^2}},$$

where  $M$  = maximum bending moment of the transverse forces in pound-inches,  $H$  = horse-power transmitted,  $n$  = No. of revs. per minute, and  $t$  = the safe allowable tensile or compressive working strength of the material.

*Guest's Formula* for maximum tension or compression unit stress is  $t = \sqrt{4S_s^2 + S^2}$  (*Phil. Mag.*, July, 1900). It is claimed by many writers to be more accurate than Rankine's formula, given above. Equivalent bending moment =  $\sqrt{M^2 + T^2}$ . (*Eng'g.*, Sept. 13 and 27, 1907; July 10, 1908; April 23, 1909.)

**Combined Compression and Torsion.** — For a vertical round shaft carrying a load and also transmitting a given horse-power, the resultant maximum compressive unit stress

$$t = \frac{4 P}{\pi d^2} + \sqrt{321,000^2 \frac{H^2}{n^2 d^2} + \frac{16 P^2}{\pi^2 d^4}},$$

In which  $P$  is the load. From this the diameter  $d$  may be found when  $t$  and the other data are given.

**Stress due to Temperature.** — Let  $l$  = length of a bar,  $A$  = its sectional area,  $c$  = coefficient of linear expansion for one degree,  $t$  = rise or fall in temperature in degrees,  $E$  = modulus of elasticity,  $\lambda$  the change of length due to the rise or fall  $t$ ; if the bar is free to expand or contract,  $\lambda = cl$ .

If the bar is held so as to prevent its expansion or contraction the stress produced by the change of temperature =  $S = ActE$ . The following are average values of the coefficients of linear expansion for a change in temperature of one degree Fahrenheit:

- For brick and stone.....  $a = 0.0000050$ ,
- For cast iron.....  $a = 0.0000056$ ,
- For wrought iron and steel....  $a = 0.0000065$ .

The stress due to temperature should be added to or subtracted from the stress caused by other external forces according as it acts to increase or to relieve the existing stress.

What stress will be caused in a steel bar 1 inch square in area by a change of temperature of 100° F.?  $S = ActE = 1 \times 0.0000065 \times 100 \times 30,000,000 = 19,500$  lbs. Suppose the bar is under tension of 19,500 lbs. between rigid abutments before the change in temperature takes place, a cooling of 100° F. will double the tension, and a heating of 100° will reduce the tension to zero.

### STRENGTH OF FLAT PLATES.

For a circular plate supported at the edge, uniformly loaded, according to Grashof,

$$f = \frac{5}{6} \frac{r^2}{t^2} p; \quad t = \sqrt{\frac{5r^2 p}{6f}}; \quad p = \frac{6ft^2}{5r^2}.$$

For a circular plate fixed at the edge, uniformly loaded,

$$f = \frac{2}{3} \frac{r^2}{t^2} p; \quad t = \sqrt{\frac{2r^2 p}{3f}}; \quad p = \frac{3ft^2}{2r^2};$$

in which  $f$  denotes the working stress;  $r$ , the radius in inches;  $t$ , the thickness in inches; and  $p$ , the pressure in pounds per square inch.

For mathematical discussion, see Lanza, "Applied Mechanics."

Lanza gives the following table, using a factor of safety of 8, with tensile strength of cast iron 20,000, of wrought iron 40,000, and of steel 80,000:

	Supported.	Fixed.
Cast iron.....	$t = 0.0182570 r \sqrt{\frac{p}{c}}$	$t = 0.0163300 r \sqrt{\frac{p}{c}}$
Wrought iron.....	$t = 0.0117850 r \sqrt{\frac{p}{c}}$	$t = 0.0105410 r \sqrt{\frac{p}{c}}$
Steel.....	$t = 0.0091287 r \sqrt{\frac{p}{c}}$	$t = 0.0081649 r \sqrt{\frac{p}{c}}$

For a circular plate supported at the edge, and loaded with a concentrated load  $P$  applied at a circumference the radius of which is  $r_0$ :

$$f = \left( \frac{4}{3} \log \frac{r}{r_0} + 1 \right) \frac{P}{\pi t^2} = c \frac{P}{\pi t^2};$$

for	$\frac{r}{r_0} = 10$	20	30	40	50;
	$c = 4.07$	5.00	5.53	5.92	6.22;
	$t = \sqrt{\frac{cP}{\pi f}};$	$P = \frac{\pi t^2 f}{c}.$			

The above formulæ are deduced from theoretical considerations, and give thicknesses much greater than are generally used in steam-engine cylinder-heads. (See empirical formulæ under Dimensions of Parts of Engines.) The theoretical formulæ seem to be based on incorrect or incomplete hypotheses, but they err in the direction of safety.

**Thickness of Flat Cast-iron Plates to resist Bursting Pressures.**—Capt. John Ericsson (Church's Life of Ericsson) gave the following rules: The proper thickness of a square cast-iron plate will be obtained by the following: Multiply the side in feet (or decimals of a foot) by  $\frac{1}{4}$  of the pressure in pounds and divide by 850 times the side in inches; the quotient is the square of the thickness in inches.

For a circular plate, multiply 11-14 of the diameter in feet by  $\frac{1}{4}$  of the pressure on the plate in pounds. Divide by 850 times 11-14 of the diameter in inches. [Extract the square root.]

Prof. Wm. Harkness, *Eng'g News*, Sept. 5, 1895, shows that these rules can be put in a more convenient form, thus: For square plates  $T = 0.00495 S \sqrt{p}$ , and for circular plates  $T = 0.00439 D \sqrt{p}$ , where  $T$  = thickness of plate,  $S$  = side of the square,  $D$  = diameter of the circle, and  $p$  = pressure in lbs. per sq. in. Professor Harkness, however, doubts the value of the rules, and says that no satisfactory theoretical solution has yet been obtained.

**The Strength of Unstayed Flat Surfaces.** — Robert Wilson (*Eng'g*, Sept. 24, 1877) draws attention to the apparent discrepancy between the results of theoretical investigations and of actual experiments on the strength of unstayed flat surfaces of boiler-plate, such as the unstayed flat crowns of domes and of vertical boilers.

On trying to make the rules given by the authorities agree with the results of his experience of the strength of unstayed flat ends of cylindrical boilers and domes that had given way after long use, Mr. Wilson was led to believe that the rules give the breaking strength much lower than it actually is. He describes a number of experiments made by Mr. Nichols of Kirkstall, which gave results varying widely from each other, as the method of supporting the edges of the plate was varied, and also varying widely from the calculated bursting pressures, the actual results being in all cases very much the higher. Some conclusions drawn from these results are:

1. Although the bursting pressure has been found to be so high, boiler-makers must be warned against attaching any importance to this, since the plates deflected almost as soon as any pressure was put upon them and sprang back again on the pressure being taken off. This springing of the plate in the course of time inevitably results in grooving or channelling, which, especially when aided by the action of the corrosive acids in the water or steam, will in time reduce the thickness of the plate, and bring about the destruction of an unstayed surface at a very low pressure.

2. Since flat plates commence to deflect at very low pressures, they should never be used without stays; but it is better to dish the plates when they are not stayed by flues, tubes, etc.

3. Against the commonly accepted opinion that the limit of elasticity should never be reached in testing a boiler or other structure, these experiments show that an exception should be made in the case of an unstayed flat end-plate of a boiler, which will be safer when it has assumed a permanent set that will prevent its becoming grooved by the continual variation of pressure in working. The hydraulic pressure in this case simply does what should have been done before the plate was fixed, that is, dishes it.

4. These experiments appear to show that the mode of attaching by flange or by an inside or outside angle-iron exerts an important influence on the manner in which the plate is strained by the pressure.

When the plate is secured to an angle-iron, the stretching under pressure is, to a certain extent, concentrated at the line of rivet-holes, and the plate partakes rather of a beam supported than fixed round the edge. Instead of the strength increasing as the square of the thickness, when the plate is attached by an angle-iron, it is probable that the strength does not increase even directly as the thickness, since the plate gives way simply by stretching at the rivet-holes, and the thicker the plate, the less uniformly is the strain borne by the different layers of which the plate may be considered to be made up. When the plate is flanged, the flange becomes compressed by the pressure against the body of the plate, and near the rim, as shown by the contrary flexure, the inside of the plate is stretched more than the outside, and it may be by a kind of shearing action that the plate gives way along the line where the crushing and stretching meet.

5. These tests appear to show that the rules deduced from the theoretical investigations of Lamé, Rankine, and Grashof are not confirmed by experiment, and are therefore not trustworthy.

The rules of Lamé, etc., apply only within the elastic limit. (*Eng'g*, Dec. 13, 1895.)

**Unbraced Wrought-iron Heads of Boilers, etc.** (*The Locomotive*, Feb., 1890). — Few experiments have been made on the strength of flat heads, and our knowledge of them comes largely from theory. Experiments have been made on small plates  $1/16$  of an inch thick,



yet the data so obtained cannot be considered satisfactory when we consider the far thicker heads that are used in practice, although the results agreed well with Rankine's formula. Mr. Nichols has made experiments on larger heads, and from them he has deduced the following rule: "To find the proper thickness for a flat unstayed head, multiply the area of the head by the pressure per square inch that it is to bear safely, and multiply this by the desired factor of safety (say 8); then divide the product by ten times the tensile strength of the material used for the head." His rule for finding the bursting pressure when the dimensions of the head are given is: "Multiply the thickness of the end-plate in inches by ten times the tensile strength of the material used, and divide the product by the area of the head in inches."

In Mr. Nichols's experiments the average tensile strength of the iron used for the heads was 44,800 pounds. The results he obtained are given below, with the calculated pressure, by his rule, for comparison.

1. An unstayed flat boiler-head is  $34\frac{1}{2}$  inches in diameter and  $\frac{9}{16}$  inch thick. What is its bursting pressure? The area of a circle  $34\frac{1}{2}$  inches in diameter is 935 square inches; then  $\frac{9}{16} \times 44,800 \times 10 = 252,000$ , and  $252,000 \div 935 = 270$  pounds, the calculated bursting pressure. The head actually burst at 280 pounds.

2. Head  $34\frac{1}{2}$  inches in diameter and  $\frac{3}{8}$  inch thick. The area = 935 square inches; then,  $\frac{3}{8} \times 44,800 \times 10 = 168,000$ , and  $168,000 \div 935 = 180$  pounds, calculated bursting pressure. This head actually burst at 200 pounds.

3. Head  $26\frac{1}{4}$  inches in diameter, and  $\frac{3}{8}$  inch thick. The area 541 square inches; then,  $\frac{3}{8} \times 44,800 \times 10 = 168,000$ , and  $168,000 \div 541 = 311$  pounds. This head burst at 370 pounds.

4. Head  $28\frac{1}{2}$  inches in diameter and  $\frac{3}{8}$  inch thick. The area = 638 square inches; then,  $\frac{3}{8} \times 44,800 \times 10 = 168,000$ , and  $168,000 \div 638 = 263$  pounds. The actual bursting pressure was 300 pounds.

In the third experiment, the amount the plate bulged under different pressures was as follows:

At pounds per sq. in. ....	10	20	40	80	120	140	170	200
Plate bulged .....	$\frac{1}{32}$	$\frac{1}{16}$	$\frac{1}{8}$	$\frac{1}{4}$	$\frac{3}{8}$	$\frac{1}{2}$	$\frac{5}{8}$	$\frac{3}{4}$

The pressure was now reduced to zero, and the end sprang back  $\frac{3}{16}$  inch, leaving it with a permanent set of  $\frac{9}{16}$  inch. The pressure of 200 lbs. was again applied on 36 separate occasions during an interval of five days, the bulging and permanent set being noted on each occasion, but without any appreciable difference from that noted above.

The experiments described were confined to plates not widely different in their dimensions, so that Mr. Nichols's rule cannot be relied upon for heads that depart much from the proportions given in the examples.

**Strength of Stayed Surfaces.** — A flat plate of thickness  $t$  is supported uniformly by stays whose distance from center to center is  $a$ , uniform load  $p$  lbs. per square inch. Each stay supports  $pa^2$  lbs. The greatest stress on the plate is

$$f = \frac{2a^2}{9t^2} p. \quad (\text{Unwin.})$$

For additional matter on this subject see strength of Steam Boilers.

**Stresses in Steel Plating due to Water-pressure,** as in plating of vessels and bulkheads (*Engineering*, May 22, 1891, page 629).

Mr. J. A. Yates has made calculations of the stresses to which steel plates are subjected by external water-pressure, and arrives at the following conclusions:

Assume  $2a$  inches to be the distance between the frames or other rigid supports, and let  $d$  represent the depth in feet, below the surface of the water, of the plate under consideration,  $t$  = thickness of plate in inches,  $D$  the deflection from a straight line under pressure in inches, and  $P$  = stress per square inch of section.

For outer bottom and ballast-tank plating,  $a = 420t/d$ ,  $D$  should not be greater than  $0.05 \times 2a/12$ , and  $P/2$  not greater than 2 to 3 tons; while for bulkheads, etc.,  $a = 2352t/d$ ,  $D$  should not be greater than



0.1 X 2a/12, and P/2 not greater than 7 tons. To illustrate the application of these formulæ the following cases have been taken:

For Outer Bottom, etc.			For Bulkheads, etc.		
Thick-ness of Plating.	Depth below Water.	Spacing of Frames should not exceed	Thick-ness of Plating.	Depth of Water.	Maximum Spacing of Rigid Stiffeners.
in.	ft.	in.	in.	ft.	ft. in.
1/2	20	About 21	1/2	20	9 10
1/2	10	" 42	3/8	20	7 4
3/8	18	" 18	3/8	10	14 8
3/8	9	" 36	1/4	20	4 10
1/4	10	" 20	1/4	10	9 8
1/4	5	" 40	1/8	10	4 10

It would appear that the course which should be followed in stiffening bulkheads is to fit substantially rigid stiffening frames at comparatively wide intervals, and only work such light angles between as are necessary for making a fair job of the bulkhead.

**SPHERICAL SHELLS AND DOMED BOILER-HEADS.**

To find the Thickness of a Spherical Shell to resist a given Pressure. — Let *d* = diameter in inches, and *p* the internal pressure per square inch. The total pressure which tends to produce rupture around the great circle will be  $\frac{1}{4}\pi d^2p$ . Let *S* = safe tensile stress per square inch, and *t* the thickness of metal in inches; then the resistance to the pressure will be  $\pi dtS$ . Since the resistance must be equal to the pressure,

$$\frac{1}{4}\pi d^2p = \pi dtS. \text{ Whence } t = \frac{pd}{4S}.$$

The same rule is used for finding the thickness of a hemispherical head to a cylinder, as of a cylindrical boiler.

Thickness of a Domed Head of a Boiler. — If *S* = safe tensile stress per square inch, *d* = diameter of the shell in inches, and *t* = thickness of the shell,  $t = pd \div 2S$ ; but the thickness of a hemispherical head of the same diameter is  $t = pd \div 4S$ . Hence if we make the radius of curvature of a domed head equal to the diameter of the boiler, we shall have  $t = \frac{2pd}{4S} = \frac{pd}{2S}$ , or the thickness of such a domed head will be equal to the thickness of the shell.

**THICK HOLLOW CYLINDERS UNDER TENSION.**

Lamé's formula, which is generally used, gives

$$t = r_1 \left\{ \left( \frac{h+p}{h-p} \right)^{\frac{1}{2}} - 1 \right\}$$

*t* = thickness; *r*<sub>1</sub> = inside and *r*<sub>2</sub> = outside radius;  
*h* = maximum allowable hoop tension at the interior of the cylinder;  
*p* = intensity of interior pressure;  
*s* = tension at the exterior of the cylinder.

$$h = p \frac{r_2^2 + r_1^2}{r_2^2 - r_1^2}; \quad s = p \frac{2r_1^2}{r_2^2 - r_1^2}; \quad r_2 = r_1 \left( \frac{h+p}{h-p} \right)^{\frac{1}{2}}.$$

**EXAMPLE:** Let maximum unit stress at the inner edge of the annulus = 8000 lbs. per square inch, radius of cylinder = 4 inches, interior pressure = 4000 lbs. per square inch. Required the thickness and the tension at the exterior surface.

$$t = 4 \left\{ \left( \frac{8000 + 4000}{8000 - 4000} \right)^{\frac{1}{2}} - 1 \right\} = 4 (\sqrt{3} - 1) = 2.928 \text{ inches.}$$

$$s = p \frac{2r_1^2}{r_2^2 - r_1^2} = 4000 \times \frac{2 \times 16}{48 - 16} = 4000 \text{ lbs. per sq. in.}$$

For short cast-iron cylinders, such as are used in hydraulic presses, it is doubtful if the above formulæ hold true, since the strength of the cylindrical portion is reinforced by the end. In that case the strength would be higher than that calculated by the formula. A rule used in practice for such presses is to make the thickness =  $1/10$  of the inner circumference, for pressures of 3000 to 4000 lbs. per square inch.

**Hooped Cylinders.** — For very high pressures, as in large guns, hoops or outer tubes of forged steel are shrunk on inner tubes, thus bringing a compressive stress on the latter which assists in resisting the tension due to the internal pressure. For discussion of Lamé's, and other formulæ for built-up guns, see Merriman's "Mechanics of Materials."

### THIN CYLINDERS UNDER TENSION.

Let  $p$  = safe working pressure in lbs. per sq. in.;

$d$  = diameter in inches;

$T$  = tensile strength of the material, lbs. per sq. in.;

$t$  = thickness in inches;

$f$  = factor of safety;

$c$  = ratio of strength of riveted joint to strength of solid plate.

$$fpd = 2Ttc; \quad p = \frac{2Ttc}{df}; \quad t = \frac{fpd}{2Tc}.$$

If  $T = 50,000$ ,  $f = 5$ , and  $c = 0.7$ ; then

$$p = \frac{14,000t}{d}; \quad t = \frac{dp}{14,000}.$$

The above represents the strength resisting rupture along a longitudinal seam. For resistance to rupture in a circumferential seam, due to pressure on the ends of the cylinder, we have  $\frac{p\pi d^2}{4} = \frac{Tt\pi dc}{f}$ ;

$$\text{whence } p = \frac{4Ttc}{df}.$$

Or the strength to resist rupture around a circumference is twice as great as that to resist rupture longitudinally; hence boilers are commonly single-riveted in the circumferential seams and double-riveted in the longitudinal seams.

### CARRYING CAPACITY OF STEEL ROLLERS AND BALLS.

**Carrying Capacity of a Steel Roller between Flat Plates.** — (Merriman, *Mech. of Mats.*) Let  $S$  = maximum safe unit stress of the material,  $l$  = length of the roller in inches,  $d$  = diameter,  $E$  = modulus of elasticity,  $W$  = load, then  $W = 2/3 ldS (2S/E)^{\frac{1}{2}}$ . Taking  $w = W/l$ , and  $S = 15,000$  and  $E = 30,000,000$  lbs. per sq. in. for steel the formula reduces to  $w = 316 d$ . Cooper's specifications for bridges, 1901, gives  $w = 300 d$ . (The rule given in some earlier specifications,  $w = 1200 \sqrt{d}$ , is erroneous.) The formula assumes that only the roller is deformed by the load, but experiments show that the plates also are deformed, and that the formula errs on the side of safety. Experiments by Crandall

and Marston on steel rollers of diameters from 1 to 16 in. show that their crushing loads are closely given by the formula  $W = 880 ld$ . (See Roller Bearings.)

**Spherical Rollers.**—With the same notation as above,  $d$  being the diameter of the sphere,  $S = \sqrt{WE \div 1/4 \pi d^2}$ ;  $W = 1/4 \pi d^2 S^2 \div E$ . The diameter of a sphere to carry a given load with an allowable unit-stress  $S$  is  $d = 2 \sqrt{WE \div \pi S^2}$ . This rule assumes that there is no deformation of the plates between which the sphere acts, hence it errs on the side of safety. (See Ball Bearings.)

### RESISTANCE OF HOLLOW CYLINDERS TO COLLAPSE.

Fairbairn's empirical formula (*Phil. Trans.*, 1858) is

$$p = 9,675,600 \frac{t^{2.19}}{ld} \dots \dots \dots (1)$$

where  $p$  = pressure in lb. per square inch,  $t$  = thickness of cylinder,  $d$  = diameter, and  $l$  = length, all in inches.

He recommends the simpler formula

$$p = 9,675,600 \frac{t^2}{ld} \dots \dots \dots (2)$$

as sufficiently accurate for practical purposes, for tubes of considerable diameter and length.

The diameters of Fairbairn's experimental tubes were 4, 6, 8, 10, and 12 inches, and their lengths ranged between 19 and 60 inches.

His formula (2) was until about 1908 generally accepted as the basis of rules for strength of boiler-flues. In some cases, however, limits were fixed to its application by a supplementary formula.

Lloyd's Register contains the following formula for the strength of circular boiler-flues, viz.,

$$P = \frac{89,600 t^2}{Ld} \dots \dots \dots (3)$$

The English Board of Trade prescribes the following formula for circular flues, when the longitudinal joints are welded, or made with riveted butt-straps, viz.,

$$P = \frac{90,000 t^2}{(L + 1)d} \dots \dots \dots (4)$$

For lap-joints and for inferior workmanship the numerical factor may be reduced as low as 60,000.

The rules of Lloyd's Register, and those of the Board of Trade, prescribe further, that in no case the value of  $P$  must exceed  $800 t/d$ . (5)

In formulæ (3), (4), (5)  $P$  is the highest working pressure in pounds per square inch,  $t$  and  $d$  are the thickness and diameter in inches,  $L$  is the length of the flue in feet measured between the strengthening rings, in case it is fitted with such. Formula (3) is the same as formula (2), with a factor of safety of 9.

Nystrom has deduced from Fairbairn's experiments the following formula for the collapsing strength of flues:

$$p = 692,800 \frac{t^2}{d \sqrt{l}} \dots \dots \dots (6)$$

where  $p$ ,  $t$ ,  $l$ , and  $d$  have the same meaning as in formula (1), Nystrom considers a factor of safety of 4 sufficient in applying his formula. (See "A New Treatise on Steam Engineering," by J. W. Nystrom, p. 106.)

Formulæ (1), (3), and (6) have the common defect that they make the collapsing pressure decrease indefinitely with increase of length, and *vice versa*.

D. K. Clark, in his "Manual of Rules," etc., p. 696, gives the dimensions of six flues, selected from the reports of the Manchester Steam-users' Association, 1862-69, which collapsed while in actual use in boilers. These flues varied from 24 to 60 inches in diameter, and from  $3/16$  to  $3/8$  inch in thickness. They consisted of rings of plates riveted together, with one or two longitudinal seams, but all of them unfortified by intermediate flanges or strengthening rings. From the data Clark



deduced the following formula "for the average resisting force of common boiler-flues," viz.,

$$p = t^2 \left( \frac{50,000}{d} - 500 \right) \dots \dots \dots (7)$$

where  $p$  is the collapsing pressure in pounds per square inch, and  $d$  and  $t$  are the diameter and thickness expressed in inches.

Instances of collapsed flues of Cornish and Lancashire boilers collated by Clark (S. E., vol. i, p. 643), showed that the resistance to collapse of flues of 3/8-in. plates, 18 to 43 ft. long, and 30 to 50 in. diameter, varied as the 1.75 power of the diameter. Thus,

For diameters of.....	30	35	40	45	50	in.
The collapsing pressures were...	76	58	45	37	30	lb. per sq. in.
For 7/16-in. plates the collapsing pressures were.....			60	49	42	lb. per sq. in.

C. R. Roelker, in *Van Nostrand's Magazine*, March, 1881, says that Nystrom's formula, (6), gives a closer agreement of the calculated with the actual collapsing pressures in experiments on flues of every description than any of the other formulæ.

**Formula for Corrugated Furnaces** (*Eng'g*, July 24, 1891, p. 102).—As the result of a series of experiments on the resistance to collapse of Fox's corrugated furnaces, the Board of Trade and Lloyd's Register altered their formulæ for these furnaces in 1891 as follows:

Board of Trade formula is altered from

$$\frac{12,500 \times T}{D} = WP \text{ to } \frac{14,000 \times T}{D} = WP.$$

$T$  = thickness in inches;  $D$  = mean diameter of furnace;  $WP$  = working pressure, lb. per sq. in.

Lloyd's formula is altered from

$$\frac{1000 \times (T - 2)}{D} = WP \text{ to } \frac{1234 \times (T - 2)}{D} = WP.$$

$T$  = thickness in sixteenths of an inch;

$D$  = greatest diameter of furnace;

$WP$  = working pressure in pounds per square inch.

**Stewart's Experiments.** — Prof. Reid T. Stewart (*Trans. A.S.M.E.*, xxvii, 730) made two series of tests on Bessemer steel lap-welded tubes 3 to 10 ins. diam. One series was made on tubes 8 5/8 in. outside diam. with the different commercial thicknesses of wall, and in lengths of 2 1/2, 5, 10, 15 and 20 ft. between transverse joints tending to hold the tube in a circular form. A second series was made on single lengths of 20 ft. Seven sizes, from 3 to 10 in. outside diam., in all the commercial thicknesses obtainable, were tested. The tests showed that all the old formulæ were inapplicable to the wide range of conditions found in modern practice. The principal conclusions drawn from the research are as follows:

1. The length of tube, between transverse joints tending to hold it in circular form, has no practical influence upon the collapsing pressure of a commercial lap-welded tube so long as this length is not less than about six diameters of tube.

2. The formulæ, based upon this research, for the collapsing pressures of modern lap-welded Bessemer steel tubes, for all lengths greater than six diameters, are as follows:

$$P = 1,000 \left( 1 - \sqrt{1 - 1600 \frac{t^2}{d^2}} \right) \dots \dots \dots (A)$$

$$P = 86,670 \frac{t}{d} - 1386 \dots \dots \dots (B)$$

Where  $P$  = collapsing pressure, pounds per sq. inch,  $d$  = outside diameter of tube in inches,  $t$  = thickness of wall in inches.

Formula A is for values of  $P$  less than 581 pounds, or for values of  $\frac{t}{d}$



less than 0.023, while formula B is for values greater than these. When applying these formulæ, to practice, a suitable factor of safety must be applied.

3. The apparent fibre stress under which the different tubes failed varied from about 7000 lbs. for the relatively thinnest to 35,000 lbs. per sq. in. for the relatively thickest walls. Since the average yield point of the material was 37,000 and the tensile strength 58,000 lbs. per sq. in., it would appear that the strength of a tube subjected to a fluid collapsing pressure is not dependent alone upon either the elastic limit or ultimate strength of the material constituting it. The element of greatest weakness in a tube is its departure from roundness, even when this departure is relatively small.

The table on the following page is a condensed statement of the principal results of the tests.

**Rational Formulæ for Collapse of Tubes.** (S. E. Slocum, *Eng'g*, Jan. 8, 1909.)

Heretofore designers have been forced to rely either upon the antiquated experiments of Fairbairn, which were known to be in error by as much as 100% in many cases, or else to apply the theoretical formulæ of Love and others, without knowing how far the assumptions on which these formulæ are based are actually realized.

A rational formula for thin tubes under external pressure, due to A. E. H. Love, is

$$P = [2E/(1 - m^2)](t/D)^3, \dots \dots \dots (1)$$

in which  $P$  = collapsing pressure in lbs. per sq. in.

$E$  = modulus of elasticity in lbs. per sq. in.

$m$  = Poisson's ratio of lateral to transverse deformation.

$t$  = thickness of tube wall in ins.

$D$  = external tube diameter in ins.

For thick tubes a special case of Lamé's general formula is

$$P = 2u[(t/D) - (t/D)^2], \dots \dots \dots (2)$$

in which  $u$  = ultimate compressive strength in lbs. per sq. in.

The average values of the elastic constants are for steel,  $E = 30,000,000$ ,  $m = 0.295$ ,  $u = 40,000$ ; and for brass,  $E = 14,000,000$ ,  $m = 0.357$ ,  $u = 11,000$ .

Hence, for thin steel tubes,  $P = 65,720,000 (t/D)^3 \dots \dots \dots (3)$

For thick steel tubes,  $P = 80,000 [(t/D) - (t/D)^2] \dots \dots \dots (4)$

For thin brass tubes,  $P = 32,090,000 (t/D)^3 \dots \dots \dots (5)$

For thick brass tubes,  $P = 22,000 [(t/D) - (t/D)^2] \dots \dots \dots (6)$

It is desirable to introduce a correction factor  $C$  in (1) which shall allow for the average ellipticity and variation in thickness. The correction for ellipticity =  $C_1 = (D_{\min}/D_{\max})^3$ , and that for variation in thickness =  $C_2 = (t_{\min}/t_{\text{aver}})^3$ . From Stewart's twenty-five experiments  $C_1 = 0.967$  and  $C_2 = 0.712$ . The correction factor  $C = C_1 C_2 = 0.69$ ; and (1) becomes

$$P = C [2E/(1 - m^2)](t/D)^3 \dots \dots \dots (7)$$

in which  $C = 0.69$  for Stewart's lap-welded steel flues,  $t$  = average thickness in ins., and  $D$  = maximum diameter in ins.

The empirical formulas obtained by Carman (Univ. of Illinois, Bull. No. 17, 1906), are for thin cold-drawn seamless steel tubes,

$$P = 50,200,000 (t/D)^3,$$

and for thin seamless brass tubes,

$$P = 25,150,000 (t/D)^3.$$

Carman assigns 0.025 as the upper limit of  $t/D$  for thin tubes and 0.03 as the lower limit of  $t/D$  for thick tubes. Stewart assigns 0.023 as the limit of  $t/D$  between thin and thick tubes.

Comparing these with (3) and (5), it is evident that they correspond to a correction factor of 0.76 for the steel tubes and 0.78 for the brass tubes. Since Carman's experiments were performed on seamless drawn tubes, while Stewart used lap-welded tubes, it might have been anti-

COLLAPSING PRESSURE OF LAP-WELDED STEEL TUBES.

Outside Diameter, 85/8 In.; Length of Pipe, 20 Ft.

Thick- ness, In.	Length, Ft.	Bursting Pressure, Lbs. per Sq. In.	Aver- age.	Outside Diam. In.	Thick- ness.	Bursting Pressure.	Aver- age.
0.176	2.21	815-1085	977	3	0.112	1550-2175	1860
0.180	4.70	525-705	792	3	0.143	2575-3350	2962
0.181	10.08	455-650	565	3	0.188	3700-4200	4095
0.184	14.71	425-610	548	4	0.119	860-1030	964
0.185	19.72	450-625	536	4	0.175	2050-2540	2280
0.212	2.21	1240-1353	1314	4	0.212	3075-3375	3170
0.212	4.70	805-975	907	4	0.327	5425-5625	5560
0.217	10.50	700-960	841	6	0.130	450-640	524
0.219	12.79	750-1115	905	6	0.167	715-1110	928
0.268	2.14	1475-2200	1872	6	0.222	1200-2075	1797
0.274	4.64	1345-2030	1684	6	0.266	1750-2890	2441
0.272	9.64	1150-1908	1583	7	0.160	515-675	592
0.273	14.64	1250-1725	1485	7	0.242	1525-1850	1680
0.268	19.64	1250-1520	1419	7	0.279	1835-2445	2147
0.311	2.16	2290-2490	2397	8.64	0.185	450-625	536
0.306	4.64	1795-2325	2073	8.66	0.268	1250-1520	1419
0.306	9.64	1585-2055	1807	8.67	0.354	1830-2180	2028
0.309	14.64	1520-2025	1781	10	0.165	210-240	225
0.302	19.75	1575-1960	1762	10	0.194	305-425	383
.....	.....	.....	.....	10	0.316	1275-1385	1319

COLLAPSING PRESSURE OF LAP-WELDED STEEL TUBES (LBS. PER SQ. IN.)  
Calculated by Stewart's Formulæ.

Thickness.	Outside Diameters, Inches.										
	2 In.	2 1/2 In.	3 In.	4 In.	5 In.	6 In.	7 In.	8 In.	9 In.	10 In.	11 In.
0.10	2947	2081	1503	781	.....	.....	.....	.....	.....	.....	.....
0.12	3814	2774	2081	1214	694	400	.....	.....	.....	.....	.....
0.14	4671	3468	2659	1647	1041	636	400	286	217	.....	.....
0.16	5548	4161	3236	2081	1387	925	595	400	297	232	187
0.18	6414	4854	3814	3514	1734	1214	843	564	400	306	244
0.20	7281	5548	4392	2947	2081	1503	1090	781	542	400	314
0.22	8148	6241	4970	3381	2427	1792	1338	997	733	525	400
0.24	9014	6934	5548	3814	2774	2081	1586	1214	935	694	512
0.26	9881	7628	6125	4248	3121	2370	1833	1431	1118	867	633
0.28	.....	8321	6703	4681	3468	2669	2081	1647	1310	1041	820
0.30	.....	9014	7281	5114	3814	2947	2328	1864	1503	1214	978
0.32	.....	9708	7859	5548	4161	3236	2576	2081	1696	1387	1135
0.34	.....	.....	8437	5981	4508	3525	2824	2297	1888	1561	1293
0.36	.....	.....	9014	6414	4854	3814	3071	2514	2081	1734	1450
0.38	.....	.....	9592	6848	5201	4103	3319	2731	2273	1907	1608
0.40	.....	.....	.....	7281	5548	4392	3567	2947	2466	2081	1766
0.42	.....	.....	.....	7714	5894	4681	3814	3164	2659	2254	1923
0.44	.....	.....	.....	8148	6241	4970	4062	3381	2851	2427	2081
0.46	.....	.....	.....	8581	6588	5259	4309	3598	3044	2601	2238
0.48	.....	.....	.....	9014	6934	5548	4557	3814	3236	2774	2396
0.50	.....	.....	.....	9448	7281	5887	4805	4031	3429	2947	2554

pated that the latter would develop a smaller percentage of the theoretical strength for perfect tubes than the former.

Formula (2) for thick tubes when corrected for ellipticity and variation in thickness reads

$$P = 2 u_c C (t/D) [1 - C (t/D)] \dots \dots \dots (8)$$

in which  $t$  = average thickness, and  $C = C_1, C_2, C_1$  being equal to  $D_{\min}/D_{\max}$ ;  $C_2 = t_{\text{average}}/t_{\min}$ .

From Stewart's experiments, average ellipticity  $C_1 = 0.9874$ , and average variation in thickness  $C_2 = 0.9022$ ;  $\therefore C = 0.9874 \times 0.9022 = 0.89$ .

We have then, for thick lap-welded steel flues,

$$P = 2 u_c 0.89 (t/D) [1 - 0.89 (t/D)]$$

and for thin lap-welded steel flues,

$$P = 0.69 [2 E / (1 - m^2)] (t/D)^3$$

in which  $E = 30,000,000$ ,  $m = 0.295$ , and  $u_c = 38,500$  lbs. per sq. in.

The experimental data of Stewart and Carman have made it possible to correct the rational formulas of Love and Lamé to conform to actual conditions; and the result is a pair of supplementary formulas (7) and (8), which cover the entire range of materials, diameters, and thicknesses for long tubes of circular section. All that now remains to be done is the experimental determination of the correction constants for other types of commercial tubes than those already tested.

### HOLLOW COPPER BALLS.

Hollow copper balls are used as floats in boilers or tanks, to control feed and discharge valves, and regulate the water-level.

They are spun up in halves from sheet copper, and a rib is formed on one half. Into this rib the other half fits, and the two are then soldered or brazed together. In order to facilitate the brazing, a hole is left on one side of the ball, to allow air to pass freely in or out; and this hole is made use of afterwards to secure the float to its stem. The original thickness of the metal may be anything up to about  $1/16$  of an inch, if the spinning is done on a hand lathe, though thicker metal may be used when special machinery is provided for forming it. In the process of spinning, the metal is thinned down in places by stretching; but the thinnest place is neither at the equator of the ball (i.e., along the rib) nor at the poles. The thinnest points lie along two circles, passing around the ball parallel to the rib, one on each side of it, from a third to a half of the way to the poles. Along these lines the thickness may be 10, 15, or 20 per cent less than elsewhere, the reduction depending somewhat on the skill of the workman.

*The Locomotive* for October, 1891, gives two empirical rules for determining the thickness of a copper ball which is to work under an external pressure, as follows:

1. Thickness =  $\frac{\text{diameter in inches} \times \text{pressure in pounds per sq. in.}}{16,000}$ .
2. Thickness =  $\frac{\text{diameter} \times \sqrt{\text{pressure}}}{1240}$ .

These rules give the same result for a pressure of 166 lbs. only. **EXAMPLE:** Required the thickness of a 5-inch copper ball to sustain

Pressures of.....	50	100	150	166	200	250 lbs.per sq.in.
Answer by first rule.....	.0156	.0312	.0469	.0519	.0625	.0781 inch.
Answer by second rule	.0285	.0403	.0494	.0518	.0570	.0637 "



**HOLDING-POWER OF NAILS, SPIKES, AND SCREWS.**

(A. W. Wright, Western Society of Engineers, 1881.)

**Spikes.** — Spikes driven into dry cedar (cut 18 months):

Size of spikes.....	5 × 1/4 in. sq.	6 × 1/4	6 × 1/2	5 × 3/8
Length driven in.....	4 1/4 in.	5 in.	5 in.	4 1/4 in.
Pounds resistance to drawing. Av'ge. lbs.	857	821	1691	1202
From 6 to 9 tests each.....	Max. "	1159	923	2129
	Min. "	766	766	1120
			1556	687

A. M. Wellington found the force required to draw spikes 9/16 × 9/16 in., driven 4 1/4 inches into seasoned oak, to be 4281 lbs.; same spikes, etc., in unseasoned oak, 6523 lbs.

“Professor W. R. Johnson found that a plain spike 3/8 inch square driven 3 3/8 inches into seasoned Jersey yellow pine or unseasoned chestnut required about 2000 lbs. force to extract it; from seasoned white oak about 4000 and from well-seasoned locust 6000 lbs.”

Experiments in Germany, by Funk, give from 2465 to 3940 lbs. (mean of many experiments about 3000 lbs.) as the force necessary to extract a plain 1/2-inch square iron spike 6 inches long, wedge-pointed for one inch and driven 4 1/2 inches into white or yellow pine. When driven 5 inches the force required was about 1/10 part greater. Similar spikes 9/16 inches square, 7 inches long, driven 6 inches deep, required from 3700 to 6745 lbs. to extract them from pine; the mean of the results being 4873 lbs. In all cases about twice as much force was required to extract them from oak. The spikes were all driven across the grain of the wood. When driven with the grain, spikes or nails do not hold with more than half as much force.

Boards of oak or pine nailed together by from 4 to 16 tenpenny common cut nails and then pulled apart in a direction lengthwise of the boards, and across the nails, tending to break the latter in two by a shearing action, averaged about 300 to 400 lbs. per nail to separate them, as the result of many trials.

**Resistance of Drift-bolts in Timber.** — Tests made by Rust and Coolidge, in 1878.

		White Pine.	Norway Pine.
1 in. square iron drove 30 in. in 15/16-in. hole, lbs.....		26,400	19,200
1 in. round “ “ 34 “ “ 13/16-in. “ “.....		16,800	18,720
1 in. square “ “ 18 “ “ 15/16-in. “ “.....		14,600	15,600
1 in. round “ “ 22 “ “ 13/16-in. “ “.....		13,200	14,400

**Holding-power of Bolts in White Pine.** (Eng'g News, Sept. 26, 1891.)

	Round.	Square.
	Lbs.	Lbs.
Average of all plain 1-in. bolts.....	8224	8200
Average of all plain bolts, 5/8 to 1 1/8 in.....	7805	8110
Average of all bolts.....	8383	8598

Round drift-bolts should be driven in holes 13/16 of their diameter, and square drift-bolts in holes whose diameter is 14/16 of the side of the square.

**Force required to draw Screws out of Norway Pine.**

	Power required, average	
1/2" diam. drive screw 4 in. in wood.	2424 lbs.	
“ “ 4 threads per in. 5 in. in wood.	“ “	2743 “
“ “ D'ble thr'd, 3 per in., 4 in. in “	“ “	2730 “
“ “ Lag-screw, 7 per in., 1 1/2 “ “	“ “	1465 “
“ “ “ “ 6 “ “ 2 1/2 “ “	“ “	2026 “
1/2 inch R.R. spike.....	5 “ “	2191 “

**Force required to draw Wood Screws out of Dry Wood.** — Tests made by Mr. Bevan. The screws were about two inches in length, 0.22 diameter at the exterior of the threads, 0.15 diameter at the bottom, the depth of the worm or thread being 0.035 and the number of threads in one inch equal 12. They were passed through pieces of wood half an inch in thickness and drawn out by the weights stated: Beech, 460 lbs.; ash,



790 lbs.; oak, 760 lbs.; mahogany, 770 lbs.; elm, 665 lbs.; sycamore, 830 lbs.

Tests of Lag-screws in Various Woods were made by A. J. Cox, University of Iowa, 1891:

Kind of Wood.	Size Screw.	Size Hole bored.	Length in Tie.	Max. Resist. lbs.	No. Tests.
Seasoned white oak .....	5/8 in.	1/2 in.	4 1/2 in.	8037	3
" " " .....	9/16 "	7/16 "	3 "	6480	1
" " " .....	1/2 "	3/8 "	4 1/2 "	8780	2
Yellow-pine stick .....	5/8 "	1/2 "	4 "	3800	2
White cedar, unseasoned....	5/8 "	1/2 "	4 "	3405	2

**Cut versus Wire Nails.** — Experiments were made at the Watertown Arsenal in 1893 on the comparative direct tensile adhesion, in pine and spruce, of cut and wire nails. The results are stated by Prof. W. H. Burr as follows:

There were 58 series of tests, ten pairs of nails (a cut and a wire nail in each) being used. The tests were made in spruce wood in most instances. The nails were of all sizes, from 1 1/8 to 6 in. in length. In every case the cut nails showed the superior holding strength by a large percentage. In spruce, in nine different sizes of nails, both standard and light weight, the ratio of tenacity of cut to wire nail was about 3 to 2. With the "finishing" nails the ratio was roughly 3.5 to 2. With box nails (1 1/4 to 4 inches long) the ratio was roughly 3 to 2. The mean superiority in spruce wood was 61%. In white pine, cut nails, driven with taper along the grain, showed a superiority of 100%, and with taper across the grain of 135%. Also when the nails were driven in the end of the stick, i.e., along the grain, the superiority of cut nails was 100%, or the ratio of cut to wire was 2 to 1. The total of the results showed the ratio of tenacity to be about 3.2 to 2 for the harder wood, and about 2 to 1 for the softer, and for the whole taken together the ratio was 3.5 to 2.

**Nail-holding Power of Various Woods.** — Tests at the Watertown Arsenal on different sizes of nails from 8d. to 60d., reduced to holding power per sq. in. of surface in wood, gave average results, in pounds, as follows: white pine, wire, 167; cut, 405. Yellow pine, wire, 318; cut, 662. White oak, wire, 940; cut, 1216. Chestnut, cut, 683. Laurel, wire, 651; cut, 1200.

Experiments by F. W. Clay. (*Eng'g News*, Jan. 11, 1894.)

Wood.	Tenacity of 6d nails—			
	Plain.	Barbed.	Blued.	Mean.
White pine.....	106	94	135	111
Yellow pine.....	190	130	270	196
Basswood.....	78	132	219	143
White oak.....	226	300	555	360
Hemlock.....	141	201	319	220

## STRENGTH OF BOLTS.

**Effect of Initial Strain in Bolts.** — Suppose that bolts are used to connect two parts of a machine and that they are screwed up tightly before the effective load comes on the connected parts. Let  $P_1$  = the initial tension on a bolt due to screwing up, and  $P_2$  = the load afterwards added. The greatest load may vary but little from  $P_1$  or  $P_2$ , according as the former or the latter is greater, or it may approach the value  $P_1 + P_2$ , depending upon the relative rigidity of the bolts and of the parts connected. Where rigid flanges are bolted together, metal to metal, it is probable that the extension of the bolts with any additional tension relieves the initial tension, and that the total tension is  $P_1$  or  $P_2$ , but in cases where elastic packing, as india rubber, is interposed, the extension of the bolts may very little affect the initial tension, and the total strain may be nearly  $P_1 + P_2$ . Since the latter assumption is more unfavorable to the resistance of the bolt, this contingency should usually be provided for. (See Unwin, "Elements of Machine Design," for demonstration.)

Forrest E. Cardullo (*Machinery's Reference Series No. 22, 1908*) states the effect of initial stress in bolts due to screwing them tight as follows:

1. When the bolt is more elastic than the material it compresses, the stress in the bolt is either the initial stress or the force applied, whichever is greater.

2. When the material compressed is more elastic than the bolt, the stress in the bolt is the sum of the initial stress and the force applied.

Experiments on screwing up  $\frac{1}{2}$ ,  $\frac{3}{4}$ , 1 and  $1\frac{1}{4}$  in. bolts showed that the stress produced is often sufficient to break a  $\frac{1}{2}$ -in. bolt, and that the stress varies about as the square of the diameter. From these experiments Prof. Cardullo calculates what he calls the "working section" of a bolt as equal to its area at the root of the thread, less the area of a  $\frac{1}{2}$ -in. bolt at the root of the thread times twice the diameter of the bolt, and gives the following table based on this rule.

**Working Strength of Bolts. U. S. Standard Threads.**

Diameter of Bolt, inches.	Area at Root of Thread, square inches.	Working Section, square inches.	Strength of Bolt, 5000 pounds Stress.	Strength of Bolt, 6000 pounds Stress.	Strength of Bolt, 7000 pounds Stress.	Strength of Bolt, 8000 pounds Stress.	Strength of Bolt, 10,000 pounds Stress.	Strength of Bolt, 12,000 pounds Stress.
$\frac{1}{2}$	0.126	0	0	0	0	0	0	0
$\frac{5}{8}$	0.202	0.044	220	264	308	352	440	528
$\frac{3}{4}$	0.302	0.113	565	678	791	904	1,130	1,356
$\frac{7}{8}$	0.420	0.200	1,000	1,200	1,400	1,600	2,000	2,400
1	0.550	0.298	1,490	1,788	2,086	2,384	2,980	3,476
$1\frac{1}{8}$	0.694	0.411	2,055	2,466	2,877	3,288	4,110	4,932
$1\frac{1}{4}$	0.893	0.578	2,890	3,468	4,046	4,624	5,780	6,936
$1\frac{3}{8}$	1.057	0.710	3,550	4,260	4,970	5,680	7,100	8,520
$1\frac{1}{2}$	1.295	0.917	4,585	5,502	6,419	7,336	9,170	10,504
$1\frac{5}{8}$	1.515	1.105	5,525	6,630	7,735	8,840	11,050	13,260
$1\frac{3}{4}$	1.746	1.305	6,525	7,830	9,135	10,440	13,050	15,660
$1\frac{7}{8}$	2.051	1.578	7,890	9,468	11,046	12,624	15,780	18,936
2	2.302	1.798	8,990	10,788	12,586	14,384	17,980	21,576
$2\frac{1}{4}$	3.023	2.456	12,280	14,736	17,192	19,648	24,560	29,472
$2\frac{1}{2}$	3.719	3.089	15,445	18,534	21,623	24,712	30,890	37,068
$2\frac{3}{4}$	4.620	3.927	19,635	23,562	27,489	31,416	39,270	47,124
3	5.428	4.672	23,360	28,032	32,704	37,376	46,720	56,064
$3\frac{1}{4}$	6.510	5.690	28,450	34,140	39,830	45,520	56,900	68,280
$3\frac{1}{2}$	7.548	6.666	33,330	39,996	46,664	53,328	66,660	79,992

The stresses on bolts caused by tightening the nuts by a wrench may be calculated as follows: Let  $L$  = the effective length of the wrench in inches,  $P$  = the force in pounds applied at the distance  $L$ ,  $n$  = no. of threads per inch of the bolt,  $T$  = total tension on the bolt if there were no friction, then  $T = 2\pi nLP$ . Wilfred Lewis, *Trans. A. S. M. E.*, gives for the efficiency of a bolt  $E = 1 \div (1 + nd)$ , where  $d$  = external diameter of the screw.  $T \times E = 2\pi nLP \div (1 + nd)$  is the tension corrected for friction. It also expresses the load that can be lifted by screwing a nut on a bolt or a bolt into a nut.

### STRENGTH OF CHAINS.

**Formulas for Safe Load on Chains.**—Writing the formula for the safe load on chains  $P = Kd^2$ ,  $P$  in pounds,  $d$  in inches, the following figures for  $K$  are given by the authorities named.

	Open link	Stud link
Unwin	13,440; 11,200*	20,160
Weisbach	13,350	17,800
Bach	13,750; 11,000*	16,500; 13,200*

\* The lower figures are for much used chain, subject frequently to the maximum load. G. A. Goodenough and L. E. Moore, *Univ. of Illinois*

**STAND-PIPES AND THEIR DESIGN.**

(Freeman C. Coffin, New England Water Works Assoc., *Eng. News*, March 16, 1893.) See also papers by A. H. Howland, Eng. Club of Phil., 1887; B. F. Stephens, Amer. Water Works Assoc., *Eng. News*, Oct. 6 and 13, 1888; W. Kiersted, Rensselaer Soc. of Civil Eng., *Eng'g Record*, April 25 and May 2, 1891, and W. D. Pence, *Eng. News*, April and May, 1894; also, J. N. Hazlehurst's "Towers and Tanks for Water Works."

The question of diameter is almost entirely independent of that of height. The efficient capacity must be measured by the length from the high-water line to a point below which it is undesirable to draw the water on account of loss of pressure for fire-supply, whether that point is the actual bottom of the stand-pipe or above it. This allowable fluctuation ought not to exceed 50 ft., in most cases. This makes the diameter dependent upon two conditions, the first of which is the amount of the consumption during the ordinary interval between the stopping and starting of the pumps. This should never draw the water below a point that will give a good fire stream and leave a margin for still further draught for fires. The second condition is the maximum number of fire streams and their size which it is considered necessary to provide for, and the maximum length of time which they are liable to have to run before the pumps can be relied upon to reinforce them.

Another reason for making the diameter large is to provide for stability against wind-pressure when empty.

The following table gives the height of stand-pipes beyond which they are not safe against wind-pressures of 40 and 50 lbs. per square foot. The area of surface taken is the height multiplied by one half the diameter.

Diameter, feet.....	20	25	30	35
Max. height, wind 40 lbs .....	45	70	150	...
“ “ “ 50 “ .....	35	55	80	160

Any form of anchorage that depends upon connections with the side plates near the bottom is unsafe. By suitable guys the wind-pressure is resisted by tension in the guys, and the stand-pipe is relieved from wind strains that tend to overthrow it. The guys should be attached to a band of angle or other shaped iron that completely encircles the tank, and rests upon some sort of bracket or projection, and not be riveted to the tank. They should be anchored at a distance from the base equal to the height of the point at which they are attached, if possible.

The best plan is to build the stand-pipe of such diameter that it will resist the wind by its own stability.

**Thickness of the Side Plates.**

The pressure on the sides tending to rupture the plates by tension, due to the weight of the water, increases in direct ratio to the height, and also to the diameter. The strain upon a section 1 inch in height at any point is the total strain at that point divided by two — for each side is supposed to bear the strain equally. The total pressure at any point is equal to the diameter in inches, multiplied by the pressure per square inch, due to the height at that point. It may be expressed as follows:

- $H$  = height in feet, and  $f$  = factor of safety;
- $d$  = diameter in inches;
- $p$  = pressure in lbs. per square inch;
- $0.434 = p$  for 1 ft. in height;
- $s$  = tensile strength of material per square inch;
- $T$  = thickness of plate.

---

*Bulletin*, No. 18, 1907, after an extensive theoretical and experimental investigation, find that these values give maximum stresses in the external fibers of from 26,400 to 40,320 lbs. per sq. in., which they consider much too high for safety. Taking 20,000 as a permissible maximum stress, they give the formulæ for safe load  $P = 8000 d^2$  for open links and  $P = 10,000 d^2$  for stud links. They say that the stud link will within the elastic limit bear from 20 to 25% more load than the open link, but that the ultimate strength of the stud link is probably less than that of the open link. See also tables of Size and Strength of Chains, page 264.



Then the total strain on each side per vertical inch

$$= \frac{0.434 Hd}{2} = \frac{pd}{2}; \quad T = \frac{0.434 Hdf}{2s} = \frac{pdf}{2s}.$$

Mr. Coffin takes  $f = 5$ , not counting reduction of strength of joint, equivalent to an actual factor of safety of 3 if the strength of the riveted joint is taken as 60 per cent of that of the plate.

The amount of the wind strain per square inch of metal at any joint can be found by the following formula, in which

$H$  = height of stand-pipe in feet above joint;  
 $T$  = thickness of plate in inches;  
 $p$  = wind-pressure per square foot;  
 $W$  = wind-pressure per foot in height above joint;  
 $W = Dp$  where  $D$  is the diameter in feet;  
 $m$  = average leverage or movement about neutral axis  
 or central points in the circumference; or,  
 $m$  = sine of  $45^\circ$ , or 0.707 times the radius in feet.

Then the strain per square inch of plate

$$\frac{(Hw) \frac{H}{2}}{\text{circ. in ft.} \times mT}$$

Mr. Coffin gives a number of diagrams useful in the design of stand-pipes, together with a number of instances of failures, with discussion of their probable causes.

Mr. Kiersted's paper contains the following: Among the most prominent strains a stand-pipe has to bear are: that due to the static pressure of the water, that due to the overturning effect of the wind on an empty stand-pipe, and that due to the collapsing effect, on the upper rings, of violent wind storms.

For the thickness of metal to withstand safely the static pressure of water, let  $t$  = thickness of the plate iron in inches;  $H$  = height of stand-pipe in feet;  $D$  = diameter of stand-pipe in feet.

Then, assuming a tensile strength of 48,000 lbs. per square inch, a factor of safety of 4, and efficiency of double-riveted lap-joint equaling 0.6 of the strength of the solid plate,  $t = 0.00036 H \times D$ ;  $H = 10,000 t + 3.6 D$ ; which will give safe heights for thicknesses up to  $\frac{5}{8}$  to  $\frac{3}{4}$  of an inch. The same formula may also apply for greater heights and thicknesses within practical limits, if the joint efficiency be increased by triple riveting.

The conditions for the severest overturning wind strains exist when the stand-pipe is empty.

Formula for wind-pressure of 50 pounds per square foot, when  $d$  = diameter of stand-pipe in inches;  $x$  = any unknown height of stand-pipe;  $x = \sqrt{80\pi dt} = 15.85 \sqrt{dt}$ .

**Failures of Stand-pipes.** — A list showing 23 important failures inside of nine years is given in a paper by Prof. W. D. Pence, *Eng'g News*, April 5, 12, 19 and 26, May 3, 10 and 24, and June 7, 1894. His discussion of the probable causes of the failures is most valuable.

**Water Tower at Yonkers, N.Y.** — This tower, with a pipe 122 feet high and 20 feet diameter, is described in *Engineering News*, May 18, 1892.

The thickness of the lower rings is  $\frac{11}{16}$  of an inch, based on a tensile strength of 60,000 lbs. per square inch of metal, allowing 65% for the strength of riveted joints, using a factor of safety of  $3\frac{1}{2}$  and adding a constant of  $\frac{1}{8}$  inch. The plates diminish in thickness by  $\frac{1}{16}$  inch to the last four plates at the top, which are  $\frac{1}{4}$  inch thick.

The contract for steel requires an elastic limit of at least 33,000 lbs. per square inch; an ultimate tensile strength of from 56,000 to 66,000 lbs. per square inch; an elongation in 8 inches of at least 20%, and a reduction of area of at least 45%. The inspection of the work was made by the Pittsburgh Testing Laboratory. According to their report the actual conditions developed were as follows: Elastic limit from 34,020 to 39,420;



the tensile strength from 58,330 to 65,390; the elongation in 8 inches from 22 $\frac{1}{2}$  to 32%; reduction in area from 52.72 to 71.32%; 17 plates out of 141 were rejected in the inspection.

The following table is calculated by Mr. Kiersted's formulæ. The stand-pipe is intended to be self-sustaining; that is, without guys or stiffeners.

**Heights of Stand-pipes for Various Diameters and Thicknesses of Plates.**

Thickness of Plate in Fractions of an Inch.	Diameters in Feet.												
	5	6	7	8	9	10	12	14	15	16	18	20	25
3/16.....	50	55	60	65	55	50	35	.....	.....	.....	.....	.....	.....
7/32.....	55	.....	.....	.....	65	60	50	40	40	.....	.....	.....	.....
1/4.....	60	65	70	75	75	70	55	50	45	40	35	35	25
5/16.....	70	75	80	85	90	85	70	60	55	50	45	40	35
3/8.....	75	80	90	95	100	100	85	75	70	65	55	50	40
7/16.....	80	90	95	100	110	115	100	85	80	75	65	60	45
1/2.....	85	95	100	110	115	120	115	100	90	85	75	70	55
9/16.....	.....	.....	.....	115	125	130	130	110	100	95	85	80	60
5/8.....	.....	.....	.....	.....	130	135	145	120	115	105	95	85	65
11/16.....	.....	.....	.....	.....	.....	145	155	135	125	120	105	95	75
3/4.....	.....	.....	.....	.....	.....	150	165	145	135	130	115	105	80
13/16.....	.....	.....	.....	.....	.....	.....	.....	160	150	140	125	110	90
17/8.....	.....	.....	.....	.....	.....	.....	.....	.....	160	150	135	120	95
5/1.....	.....	.....	.....	.....	.....	.....	.....	.....	.....	160	145	130	105
1.....	.....	.....	.....	.....	.....	.....	.....	.....	.....	.....	155	140	110

Heights to nearest 5 feet. Rings are to build 5 feet vertically.

**WROUGHT-IRON AND STEEL WATER-PIPES.**

**Riveted Steel Water-pipes** (*Engineering News*, Oct. 11, 1890, and Aug. 1, 1891). — The use of riveted wrought-iron pipe has been common in the Pacific States for many years, the largest being a 44-inch conduit in connection with the works of the Spring Valley Water Co., which supplies San Francisco. The use of wrought iron and steel pipe has been necessary in the West, owing to the extremely high pressures to be withstood and the difficulties of transportation. As an example: In connection with the water supply of Virginia City and Gold Hill, Nev., there was laid in 1872 an 11 $\frac{1}{2}$ -inch riveted wrought-iron pipe, a part of which is under a head of 1720 feet.

In the East, an important example of the use of riveted steel water pipe is that of the East Jersey Water Co., which supplies the city of Newark. The contract provided for a maximum high service supply of 25,000,000 gallons daily. In this case 21 miles of 48-inch pipe was laid, some of it under 340 feet head. The plates from which the pipe is made are about 13 feet long by 7 feet wide, open-hearth steel. Four plates are used to make one section of pipe about 27 feet long. The pipe is riveted longitudinally with a double row, and at the end joints with a single row of rivets. Before being rolled into the trench, two of the 27-foot lengths are riveted together, thus diminishing the number of joints to be made in the trench and the extra excavation to give room for joining.

The thickness of the plates varies with the pressure, but only three thicknesses are used, 1/4, 5/16, and 3/8 inches, the pipe made of these thicknesses having a weight of 160, 185, and 225 lbs. per foot, respectively. At the works all the pipe was tested to pressure 1 $\frac{1}{2}$  times that to which it is to be subjected when in place.

An important discussion of the design of large riveted steel pipes to

resist not only the internal pressure but also the external pressure from moist earth in which they are laid, together with notes on the design of a pipe 18 ft. diam. 6000 ft. long for the Ontario Water Power Co., Niagara Falls, by Joseph Mayer, will be found in *Eng. News*, April 26, 1906.

### STRENGTH OF VARIOUS MATERIALS. EXTRACTS FROM KIRKALDY'S TESTS.

The publication, in a book by W. G. Kirkaldy, of the results of many thousand tests made during a quarter of a century by his father, David Kirkaldy, has made an important contribution to our knowledge concerning the range of variation in strength of numerous materials. A condensed abstract of these results was published in the *American Machinist*, May 11 and 18, 1893, from which the following still further condensed extracts are taken:

The figures for tensile and compressive strength, or, as Kirkaldy calls them, pulling and thrusting stress, are given in pounds per square inch of original section, and for bending strength in pounds of actual stress or pounds per  $BD^2$  (breadth  $\times$  square of depth) for length of 36 inches between supports. The contraction of area is given as a percentage of the original area, and the extension as a percentage in a length of 10 inches, except when otherwise stated. The abbreviations T. S., E. L., Contr., and Ext. are used for the sake of brevity, to represent tensile strength, elastic limit, and percentages of contraction of area, and elongation, respectively.

**Cast Iron.** — 44 tests: T. S. 15,468 to 28,740 pounds; 17 of these were unsound, the strength ranging from 15,468 to 24,357 pounds. Average of all, 23,805 pounds.

Thrusting stress, specimens 2 inches long, 1.34 to 1.5 in. diameter; 43 tests, all sound, 94,352 to 131,912; one, unsound, 93,759; average of all, 113,825.

Bending stress, bars about 1 in. wide by 2 in. deep, cast on edge. Ultimate stress 2876 to 3854; stress per  $BD^2 = 725$  to 892; average, 820. Average modulus of rupture,  $R$ , =  $\frac{3}{2}$  stress per  $BD^2 \times$  length, = 44,280. Ultimate deflection, 0.29 to 0.40 in.; average, 0.34 inch.

Other tests of cast iron, 460 tests, 16 lots from various sources, gave results with total range as follows: Pulling stress, 12,688 to 33,616 pounds; thrusting stress, 66,363 to 175,950 pounds; bending stress, per  $BD^2$ , 505 to 1128 pounds; modulus of rupture,  $R$ , 27,270 to 61,912. Ultimate deflection, 0.21 to 0.45 inch.

The specimen which was the highest in thrusting stress was also the highest in bending, and showed the greatest deflection, but its tensile strength was only 26,502.

The specimen with the highest tensile strength had a thrusting stress of 143,939 and a bending strength, per  $BD^2$ , of 979 pounds with 0.41 deflection. The specimen lowest in T. S. was also lowest in thrusting and bending, but gave 0.38 deflection. The specimen which gave 0.21 deflection had T. S., 19,188; thrusting, 104,281; and bending, 561.

**Iron Castings.** — 69 tests; tensile strength, 10,416 to 31,652; thrusting stress, ultimate per square inch, 53,502 to 132,031.

**Channel Irons.** — Tests of 18 pieces cut from channel irons. T. S. 40,693 to 53,141 pounds per square inch; contr. of area from 3.9 to 32.5%. Ext. in 10 in. from 2.1 to 22.5%. The fractures ranged all the way from 100% fibrous to 100% crystalline. The highest T. S., 53,141, with 8.1% contr. and 5.3% ext., was 100% crystalline; the lowest T. S., 40,693, with 3.9% contr. and 2.1% ext., was 75% crystalline. All the fibrous irons showed from 12.2 to 22.5% ext., 17.3 to 32.5% contr., and T. S. from 43,426 to 49,615. The fibrous irons are therefore of medium tensile strength and high ductility. The crystalline irons are of variable T. S., highest to lowest, and low ductility.

**Lowmoor Iron Bars.** — Three rolled bars  $2\frac{1}{2}$  inches diameter; tensile tests: elastic, 23,200 to 24,200; ultimate, 50,875 to 51,905; contraction, 44.4 to 42.5; extension, 29.2 to 24.3. Three hammered bars,  $4\frac{1}{2}$  inches diameter, elastic 25,100 to 24,200; ultimate, 46,810 to 49,223; contraction, 20.7 to 46.5; extension, 10.8 to 31.6. Fractures of all, 100 per cent fibrous. In the hammered bars the lowest T. S. was accompanied by lowest ductility.

**Iron Bars, Various.** — Of a lot of 80 bars of various sizes, some rolled and some hammered (the above Lowmoor bars included), the lowest T. S. (except one) 40,808 pounds per square inch, was shown by the Swedish "hoop L" bar  $3\frac{1}{4}$  inches diameter, rolled. Its elastic limit was 19,150 pounds; contraction 68.7% and extension 37.7% in 10 inches. It was also the most ductile of all the bars tested, and was 100% fibrous. The highest T. S., 60,780 pounds, with elastic limit, 29,400; contr., 36.6; and ext., 24.3%, was shown by a "Farnley" 2-inch bar, rolled. It was also 100% fibrous. The lowest ductility 2.6% contr., and 4.1% ext., was shown by a  $3\frac{3}{4}$ -inch hammered bar, without brand. It also had the lowest T. S., 40,278 pounds, but rather high elastic limit, 25,700 pounds. Its fracture was 95% crystalline. Thus of the two bars showing the lowest T. S., one was the most ductile and the other the least ductile in the whole series of 80 bars.

Generally, high ductility is accompanied by low tensile strength, as in the Swedish bars, but the Farnley bars showed a combination of high ductility and high tensile strength.

**Locomotive Forgings, Iron.** — 17 tests average, E. L., 30,420; T. S., 50,521; contr., 36.5; ext. in 10 inches, 23.8.

**Broken Anchor Forgings, Iron.** — 4 tests: average, E. L., 23,825; T. S., 40,083; contr., 3.0; ext. in 10 inches, 3.8.

Kirkaldy places these two irons in contrast to show the difference between good and bad work. The broken anchor material, he says, is of a most treacherous character, and a disgrace to any manufacturer.

**Iron Plate Girder.** — Tensile tests of pieces cut from a riveted iron girder after twenty years' service in a railway bridge. Top plate, average of 3 tests, E. L., 26,600; T. S., 40,806; contr., 16.1; ext. in 10 inches, 7.8. Bottom plate, average of 3 tests, E. L., 31,200; T. S., 44,288; contr., 13.3; ext. in 10 inches, 6.3. Web-plate, average of 3 tests, E. L., 28,000; T. S., 45,902; contr., 15.9; ext. in 10 inches, 8.9. Fractures all fibrous. The results of 30 tests from different parts of the girder prove that the iron has undergone no change during twenty years of use.

**Steel Plates.** — Six plates 100 inches long, 2 inches wide, thickness various, 0.36 to 0.97 inch. T. S., 55,485 to 60,805; E. L., 29,600 to 33,200; contr., 52.9 to 59.5; ext., 17.05 to 18.57.

**Steel Bridge Links.** — 40 links from Hammersmith Bridge, 1886.

	T. S.	E. L.	Contr.	Ext. in 100 in.	Fracture.	
					Silky.	Gran- ular.
Average of all. . . . .	67,294	38,294	34.5%	14.11%		
Lowest T. S. . . . .	60,753	36,030	30.1	15.51	30%	70%
Highest T. S. and E. L. . . . .	75,936	44,166	31.2	12.42	15	85
Lowest E. L. . . . .	64,044	32,441	34.7	13.43	30	70
Greatest Contraction . . . . .	63,745	38,118	52.8	15.46	100	0
Greatest Extension . . . . .	65,980	36,792	40.8	17.78	35	65
Least Contr. and Ext. . . . .	63,980	39,017	6.0	6.62	0	100

The ratio of elastic to ultimate strength ranged from 50.6 to 65.2 per cent; average, 56.9 per cent.

Extension in lengths of 100 inches. At 10,000 lbs. per sq. in., 0.018 to 0.024; mean, 0.020 inch; at 20,000 lbs. per sq. in., 0.049 to 0.063; mean, 0.055 inch; at 30,000 lbs. per sq. in., 0.083 to 0.100; mean, 0.090; set at 30,000 pounds per sq. in., 0 to 0.002; mean, 0.

The mean extension between 10,000 to 30,000 lbs. per sq. in. increased regularly at the rate of 0.007 inch for each 2000 lbs. per sq. in. increment of strain. This corresponds to a modulus of elasticity of 28,571,429. The least increase of extension for an increase of load of 20,000 lbs. per sq. in., 0.065 inch, corresponds to a modulus of elasticity of 30,769,231, and the greatest, 0.076 inch, to a modulus of 26,315,789.

**Steel Rails.** — Bending tests, 5 feet between supports, 11 tests of flange rails 72 pounds per yard, 4.63 inches high.



	Elastic stress. Pounds.	Ultimate stress. Pounds.	Deflection at 50,000 Pounds.	Ultimate Deflection.
Hardest . . .	34,200	60,960	3.24 ins.	8 ins.
Softest . . .	32,000	56,740	3.76 "	8 "
Mean . . . . .	32,763	59,209	3.53 "	8 "

All uncracked at 8 inches deflection.

Pulling tests of pieces cut from same rails. Mean results.

	Elastic Stress, per sq. in.	Ultimate Pounds. per sq. in.	Contraction of area of frac- ture.	Extension in 10 ins.
Top of rails . . . . .	44,200	83,110	19.9%	13.5%
Bottom of rails . . . . .	40,900	77,820	30.9%	22.8%

**Steel Tires.** — Tensile tests of specimens cut from steel tires.

**KRUPP STEEL.** — 262 Tests.

	E. L.	T. S.	Contr.	Ext. in 5 inches.
Highest . . . . .	69,250	119,079	31.9	18.1
Mean . . . . .	52,869	104,112	29.5	19.7
Lowest . . . . .	41,700	90,523	45.5	23.7

**VICKERS, SONS & Co.** — 70 Tests.

	E. L.	T. S.	Contr.	Ext. in 5 inches.
Highest . . . . .	58,600	120,789	11.8	8.4
Mean . . . . .	51,066	101,264	17.6	12.4
Lowest . . . . .	43,700	87,697	24.7	16.0

Note the correspondence between Krupp's and Vickers' steels as to tensile strength and elastic limit, and their great difference in contraction and elongation. The fractures of the Krupp steel averaged 22 per cent silky, 78 per cent granular; of the Vicker steel, 7 per cent silky, 93 per cent granular.

**Steel Axles.** — Tensile tests of specimens cut from steel axles.

**PATENT SHAFT AND AXLE TREE Co.** — 157 Tests.

	E. L.	T. S.	Contr.	Ext. in 5 inches.
Highest . . . . .	49,800	99,009	21.1	16.0
Mean . . . . .	36,267	72,099	33.0	23.6
Lowest . . . . .	31,800	61,382	34.8	25.3

**VICKERS, SONS & Co.** — 125 Tests.

	E. L.	T. S.	Contr.	Ext. in 5 inches.
Highest . . . . .	42,600	83,701	18.9	13.2
Mean . . . . .	37,618	70,572	41.6	27.5
Lowest . . . . .	30,250	56,388	49.0	37.2

The average fracture of Patent Shaft and Axle Tree Co. steel was 33 per cent silky, 67 per cent granular.

The average fracture of Vickers' steel was 88 per cent silky, 12 per cent granular.

**Steel Propeller Shafts.** — Tensile tests of pieces cut from two shafts, mean of four tests each. Hollow shaft, Whitworth, T. S., 61,290; E. L., 30,575; contr., 52.8; ext. in 10 inches, 28.6. Solid shaft, Vickers', T. S., 46,870; E. L., 20,425; contr., 44.4; ext. in 10 inches, 30.7.

Thrusting tests, Whitworth, ultimate, 56,201; elastic, 29,300; set at 30,000 lbs., 0.18 per cent; set at 40,000 lbs., 2.04 per cent; set at 50,000 lbs., 3.82 per cent.

Thrusting tests, Vickers', ultimate, 44,602; elastic, 22,250; set at 30,000 lbs., 2.29 per cent; set at 40,000 lbs., 4.69 per cent.



Shearing strength of the Whitworth shaft, mean of four tests, 40,654 lbs. per square inch, or 66.3 per cent of the pulling stress. Specific gravity of the Whitworth steel, 7.867; of the Vickers', 7.856.

**Spring Steel.** — Untempered, 6 tests, average, E. L., 67,916; T. S., 115,668; contr., 37.8; ext. in 10 inches, 16.6. Spring steel untempered, 15 tests, average, E. L., 38,785; T. S., 69,496; contr., 19.1; ext. in 10 inches, 29.8. These two lots were shipped for the same purpose, viz., railway carriage leaf springs.

**Steel Castings.** — 44 tests, E. L., 31,816 to 35,567; T. S., 54,928 to 63,840; contr., 1.67 to 15.8; ext., 1.45 to 15.1. Note the great variation in ductility. The steel of the highest strength was also the most ductile.

**Riveted Joints, Pulling Tests of Riveted Steel Plates, Triple Riveted Lap Joints, Machine Riveted, Holes Drilled.**

Plates, width and thickness, inches:				
13.50 × 0.25	13.00 × 0.51	11.75 × 0.78	12.25 × 1.01	14.00 × 0.77
Plates, gross sectional area square inches:				
3.375	6.63	9.165	12.372	10.780
Stress, total, pounds:				
199,320	332,640	423,180	528,000	455,210
Stress per square inch of gross area, joint:				
59,058	50,172	46,173	42,696	42,227
Stress per square inch of plates, solid:				
70,765	65,300	64,050	62,280	68,045
Ratio of strength of joint to solid plate:				
83.46	76.83	72.09	68.55	62.06
Ratio net area of plate to gross:				
73.4	65.5	62.7	64.7	72.9
Where fractured:				
plate at holes.	plate at holes.	plate at holes.	plate at holes.	rivets sheared
Rivets, diameter, area and number:				
0.45, 0.159, 24	0.64, 0.321, 21	0.95, 0.708, 12	1.08, 0.916, 12	0.95, 0.708, 12
Rivets, total area:				
3.816	6.741	8.496	10.992	8.496

**Strength of Welds.** — Tensile tests to determine ratio of strength of weld to solid bar.

**IRON TIE BARS. — 28 Tests.**

Strength of solid bars varied from . . . . .	43,201 to 57,065 lbs.
Strength of welded bars varied from . . . . .	17,816 to 44,586 lbs.
Ratio of weld to solid varied from . . . . .	37.0 to 79.1%

**IRON PLATES. — 7 Tests.**

Strength of solid plate from . . . . .	44,851 to 47,481 lbs.
Strength of welded plate from . . . . .	26,442 to 38,931 lbs.
Ratio of weld to solid . . . . .	57.7 to 83.9%

**CHAIN LINKS. — 216 Tests.**

Strength of solid bar from . . . . .	49,122 to 57,875 lbs.
Strength of welded bar from . . . . .	39,575 to 48,824 lbs.
Ratio of weld to solid . . . . .	72.1 to 95.4%

**IRON BARS. — Hand and Electric Machine Welded.**

32 tests, solid iron, average . . . . .	52,444
17 " electric welded, average . . . . .	46,836 ratio 89.1%
19 " hand " " . . . . .	46,899 " 89.3%

**STEEL BARS AND PLATES. — 14 Tests.**

Strength of solid . . . . .	54,226 to 64,580
Strength of weld . . . . .	28,553 to 46,019
Ratio weld to solid . . . . .	52.6 to 82.1%

The ratio of weld to solid in all the tests ranging from 37.0 to 95.4 is proof of the great variation of workmanship in welding.

**Cast Copper.** — 4 tests, average, E. L., 5900; T. S., 24,781; contr., 24.5; ext., 21.8.

**Copper Plates.** — As rolled. 22 tests, 0.26 to 0.75 in. thick; E. L., 9766 to 18,650; T. S., 30,993 to 34,281; contr., 31.1 to 57.6; ext., 39.9 to 52.2. The variation in elastic limit is due to difference in the heat at which the plates were finished. Annealing reduces the T. S. only about 1000 pounds, but the E. L. from 3000 to 7000 pounds.

Another series, 0.38 to 0.52 in. thick; 148 tests, T. S., 29,099 to 31,924; contr., 28.7 to 56.7; ext. in 10 inches, 28.1 to 41.8. Note the uniformity in tensile strength.

**Drawn Copper.** — 74 tests (0.88 to 1.08 inch diameter); T. S., 31,634 to 40,557; contr., 37.5 to 64.1; ext. in 10 inches, 5.8 to 48.2.

**Bronze from a Propeller Blade.** — Means of two tests each from center and edge. Central portion (sp. gr. 8.320), E. L., 7550; T. S., 26,312; contr., 25.4; ext. in 10 inches, 32.8. Edge portion (sp. gr. 8.550). E. L., 8950; T. S., 35,960; contr., 37.8; ext. in 10 inches, 47.9.

**Cast German Silver.** — 10 tests: E. L., 13,400 to 29,100; T. S., 23,714 to 46,540; contr., 3.2 to 21.5; ext. in 10 inches, 0.6 to 10.2.

### Thin Sheet Metal. — Tensile Strength.

German silver, 2 lots.....	75,816 to 87,129
Bronze, 4 lots.....	73,380 to 92,086
Brass, 2 lots.....	44,398 to 58,188
Copper, 9 lots.....	30,470 to 48,450
Iron, 13 lots, lengthway.....	44,331 to 59,484
Iron, 13 lots, crossway.....	39,838 to 57,350
Steel, 6 lots.....	49,253 to 78,251
Steel, 6 lots, crossway.....	55,948 to 80,799

### Wire Ropes.

#### Selected Tests Showing Range of Variation.

Description.	Circumference, inches.	Weight per Fathom.	Strands.		Diameter of Wires, inches.	Hemp Core.	Ultimate Strength, lbs.
			No. of Strands.	No. of Wires.			
Galvanized.....	7.70	53.00	6	19	0.1563	Main	339,780
Ungalvanized.....	7.00	53.10	7	19	0.1495	Main and Strands	314,860
Ungalvanized.....	6.38	42.50	7	19	0.1347	Wire Core	295,920
Galvanized.....	7.10	37.57	6	30	0.1004	Main and Strands	272,750
Ungalvanized.....	6.18	40.46	7	19	0.1302	Wire Core	268,470
Ungalvanized.....	6.19	40.33	7	19	0.1316	Wire Core	221,820
Galvanized.....	4.92	20.86	6	30	0.0728	Main and Strands	190,890
Galvanized.....	5.36	18.94	6	12	0.1104	Main and Strands	136,550
Galvanized.....	4.82	21.50	6	7	0.1693	Main	129,710
Ungalvanized.....	3.65	12.21	6	19	0.0755	Main	110,180
Ungalvanized.....	3.50	12.65	7	7	0.122	Wire Core	101,440
Ungalvanized.....	3.82	14.12	6	7	0.135	Main	98,670
Galvanized.....	4.11	11.35	6	12	0.080	Main and Strands	75,110
Galvanized.....	3.31	7.27	6	12	0.068	Main and Strands	55,095
Ungalvanized.....	3.02	8.62	6	7	0.105	Main	49,555
Ungalvanized.....	2.68	6.26	6	6	0.0963	Main and Strands	41,205
Galvanized.....	2.87	5.43	6	12	0.0560	Main and Strands	38,555
Galvanized.....	2.46	3.85	6	12	0.0472	Main and Strands	28,075
Ungalvanized.....	1.75	2.80	6	7	0.0619	Main	24,552
Galvanized.....	2.04	2.72	6	12	0.0378	Main and Strands	20,415
Galvanized.....	1.76	1.85	6	12	0.0305	Main	14,634

**Wire. — Tensile Strength.**

German silver, 5 lots.....	81,735 to 92,224
Bronze, 1 lot.....	78,049
Brass, as drawn, 4 lots.....	81,114 to 98,578
Copper, as drawn, 3 lots.....	37,607 to 46,494
Copper annealed, 3 lots.....	34,936 to 45,210
Copper (another lot), 4 lots.....	35,052 to 62,190
Copper (extension 36.4 to 0.6%).	
Iron, 8 lots.....	59,246 to 97,908
Iron (extension 15.1 to 0.7%).	
Steel, 8 lots.....	103,272 to 318,823

The steel of 318,823 T. S. was 0.047 inch diam., and had an extension of only 0.3 per cent; that of 103,272 T. S. was 0.107 inch diam., and had an extension of 2.2 per cent. One lot of 0.044 inch diam. had 267,114 T. S., and 5.2 per cent extension.

**Hemp Ropes, Untarred.** — 15 tests of ropes from 1.53 to 6.90 inches circumference, weighing 0.42 to 7.77 pounds per fathom, showed an ultimate strength of from 1670 to 33,808 pounds, the strength per fathom weight varying from 2872 to 5534 pounds.

**Hemp Ropes, Tarred.** — 15 tests of ropes from 1.44 to 7.12 inches circumference, weighing from 0.38 to 10.39 pounds per fathom, showed an ultimate strength of from 1046 to 31,549 pounds, the strength per fathom weight varying from 1767 to 5149 pounds.

**Cotton Ropes.** — 5 ropes, 2.48 to 6.51 inches circumference, 1.08 to 8.17 pounds per fathom. Strength 3089 to 23,258 pounds, or 2474 to 3346 pounds per fathom weight.

**Manila Ropes.** — 35 tests: 1.19 to 8.90 inches circumference, 0.20 to 11.40 pounds per fathom. Strength 1280 to 65,550 pounds, or 3003 to 7394 pounds per fathom weight.

**Belting.**

No. of lots.	Tensile strength per square inch.
11 Leather, single, ordinary tanned.....	3248 to 4824
4 Leather, single, Helvetia.....	5631 to 5944
7 Leather, double, ordinary tanned.....	2160 to 3572
8 Leather, double Helvetia.....	4078 to 5412
6 Cotton, solid woven.....	5648 to 8869
14 Cotton, folded, stitched.....	4570 to 7750
1 Flax, solid, woven.....	9946
1 Flax, folded, stitched.....	6389
6 Hair, solid, woven.....	3852 to 5159
2 Rubber, solid, woven.....	4271 to 4343

**Canvas.** — 35 lots: Strength, lengthwise, 113 to 408 pounds per inch; crossways, 191 to 468 pounds per inch.

The grades are numbered 1 to 6, but the weights are not given. The strengths vary considerably, even in the same number.

**Marbles.** — Crushing strength of various marbles. 38 tests, 8 kinds. Specimens were 6-inch cubes, or columns 4 to 6 inches diameter, and 6 and 12 inches high. Range 7542 to 13,720 pounds per square inch.

**Granite.** — Crushing strength, 17 tests; square columns 4 × 4 and 6 × 4, 4 to 24 inches high, 3 kinds. Crushing strength ranges 10,026 to 13,271 pounds per square inch. (Very uniform.)

**Stones.** — (Probably sandstone, local names only given.) 11 kinds, 42 tests, 6 × 6, columns 12, 18 and 24 inches high. Crushing strength ranges from 2105 to 12,122. The strength of the column 24 inches long is generally from 10 to 20 per cent less than that of the 6-inch cube.

**Stones.** — (Probably sandstone) tested for London & Northwestern Railway. 16 lots, 3 to 6 tests in a lot. Mean results of each lot ranged from 3785 to 11,956 pounds. The variation is chiefly due to the stones being from different lots. The different specimens in each lot gave results which generally agreed within 30 per cent.

**Bricks.** — Crushing strength, 8 lots; 6 tests in each lot; mean results ranged from 1835 to 9209 pounds per square inch. The maximum variation in the specimens of one lot was over 100 per cent of the lowest. In the most uniform lot the variation was less than 20 per cent.

**Wood.** — Transverse and Thrusting Tests.

	Tests.	Sizes abt. in square.	Span, inches.	Ultimate Stress.	$S = \frac{LW}{4BD^2}$	Thrusting Stress per sq. in.
Pltch pine.....	10	11½ to 12½	144	45,856 to 80,520 37,948	1096 to 1403 657	3586 to 5438 2478
Dantzle fir.....	12	12 to 13	144	to 54,152 32,856	to 790 1505	to 3423 2473
English oak.....	3	4½ × 12	120	to 39,084 23,624	to 1779 1190	to 4437 2656
American white oak...	5	4½ × 12	120	to 26,952	to 1372	to 3899

Demerara greenheart, 9 tests (thrusting).....	8169 to 10,785
Oregon pine, 2 tests.....	5888 and 7284
Honduras mahogany, 1 test.....	6769
Tobasco mahogany, 1 test.....	5978
Norway spruce, 2 tests.....	5259 and 5494
American yellow pine, 2 tests.....	3875 and 3993
English ash, 1 test.....	3025

**Portland Cement.** — (Austrian.) Cross-sections of specimens 2 × 2½ inches for pulling tests only; cubes, 3 × 3 inches for thrusting tests; weight, 98.8 pounds per imperial bushel; residue, 0.7 per cent with sieve 2500 meshes per square inch; 38.8 per cent by volume of water required for mixing; time of setting, 7 days; 10 tests to each lot. The mean results in lbs. per sq. in. were as follows:

Age.	Cement alone, Pulling.	Cement alone, Thrusting.	1 Cement, 2 Sand, Thrusting.	1 Cement, 3 Sand, Thrusting.	1 Cement, 4 Sand, Thrusting.
10 days	376	2910	893	407	228
20 days	420	3342	1023	494	275
30 days	451	3724	1172	594	338

**Portland Cement.** — Various samples pulling tests, 2 × 2½ inches cross-section, all aged 10 days, 180 tests; ranges 87 to 643 pounds per square inch.

**TENSILE STRENGTH OF WIRE.**

(From J. Bucknall Smith's Treatise on Wire.)

	Tons per sq. in. sectional area.	Pounds per sq. in. sectional area.
Black or annealed iron wire.....	25	56,000
Bright hard drawn.....	35	78,400
Bessemer, steel wire.....	40	89,600
Mild Siemens-Martin steel wire.....	60	134,000
High carbon ditto (or "improved").....	80	179,200
Crucible cast-steel "improved" wire.....	100	224,000
"Improved" cast-steel "plough".....	120	268,800
Special qualities of tempered and improved cast steel wire may attain.....	150 to 170	336,000 to 380,800



MISCELLANEOUS TESTS OF MATERIALS.

Reports of Work of the Watertown Testing-machine in 1883.  
TESTS OF RIVETED JOINTS, IRON AND STEEL PLATES.

	Thickness Plate.	Diameter, Rivets, inches.	Diameter, Punched Holes, inches.	Width Plate Tested, inches.	No. Rivets.	Pitch Rivets, inches.	Tensile Strength Joint in Net Section of Plate per square inch, pounds.	Tensile Strength Plate per square inch, pounds.	Efficiency of Joint, Per Cent.
*	3/8	11/16	3/4	10 1/2	6	1 3/4	39,300	47,180	47.0 †
*	3/8	11/16	3/4	10 1/2	6	1 3/4	41,000	47,180	49.0 †††
*	1/2	3/4	13/16	10	5	2	35,650	44,615	45.6 †††
*	1/2	3/4	13/16	10	5	2	35,150	44,615	44.9 †††
*	3/8	11/16	3/4	10	5	2	46,360	47,180	59.9 †††
*	3/8	11/16	3/4	10	5	2	46,875	47,180	60.5 †††
*	1/2	3/4	13/16	10	5	2	46,400	44,615	59.4 †††
*	1/2	3/4	13/16	10	5	2	46,140	44,615	59.2 †††
*	5/8	1	1 1/16	10 1/2	4	2 5/8	44,260	44,635	57.2 †††
*	5/8	1	1 1/16	10 1/2	4	2 5/8	42,350	44,635	54.9 †††
*	3/4	1 1/8	1 3/16	11.9	4	2.9	42,310	46,590	52.1 †††
*	3/4	1 1/8	1 3/16	11.9	4	2.9	41,920	46,590	51.7 †††
*	3/8	3/4	13/16	10 1/2	6	1 3/4	61,270	53,330	59.5 †††
†	3/8	3/4	13/16	10 1/2	6	1 3/4	60,830	53,330	59.1 †††
†	1/2	15/16	1	10	5	2	47,530	57,215	40.2 †††
†	1/2	15/16	1	10	5	2	49,840	57,215	42.3 †††
†	3/8	11/16	3/4	10	5	2	62,770	53,330	71.7 †††
†	3/8	11/16	3/4	10	5	2	61,210	53,330	69.8 †††
†	1/2	15/16	1	10	5	2	68,920	57,215	57.1 †††
†	1/2	15/16	1	10	5	2	66,710	57,215	55.0 †††
†	5/8	1	1 1/16	9 1/2	4	2 3/8	62,180	52,445	63.4 †††
†	5/8	1	1 1/16	9 1/2	4	2 3/8	62,590	52,445	63.8 †††
†	3/4	1 1/8	1 3/16	10	4	2 1/2	54,650	51,545	54.0 †††
†	3/4	1 1/8	1 3/16	10	4	2 1/2	54,200	51,545	53.4 †††

\* Iron. † Steel. ‡ Lap-joint. § Butt-joint.

The efficiency of the joints is found by dividing the maximum tensile stress on the gross sectional area of plate by the tensile strength of the material.

COMPRESSION TESTS OF 3 x 3 INCH WROUGHT-IRON BARS.

Length, inches.	Tested with Two Pin Ends, Pins 1 1/2 in. Diam. Compressive Strength, lbs. per sq. in.	Tested with Two Flat Ends. Compressive Strength, lbs. per sq. in.	Tested with One Flat and One Pin End. Compressive Strength, lbs. per sq. in.
30.....	{ 28,260 31,990	.....	.....
60.....	{ 26,310 26,640	.....	.....
90.....	{ 24,030 25,380	{ 26,780 25,580	{ 25,120 25,190
120.....	{ 20,660 20,200	{ 23,010 22,450	{ 22,450 21,870
150.....	{ 16,520 17,840	.....	.....
180.....	{ 13,010 15,700	.....	.....

Tested with Two Pin Ends. Length of Bars 120 inches.	Diameter of Pins.	Comp. Str., per sq. in., lbs.		
			7/8 inch.....	16,250
			1 1/8 inches.....	17,740
			1 7/8 ".....	21,400
	2 1/4 ".....	22,210		

### COMPRESSION OF WROUGHT-IRON COLUMNS, LATTICED BOX AND SOLID WEB.

ALL TESTED WITH PIN ENDS.

Columns made of	Length, feet.	Sectional Area, square inch.	Total Weight of Column, pounds.	Ultimate Strength, per square inch, pounds.
6-inch channel, solid web.....	10.0	9.831	432	30,220
6 " " " ".....	15.0	9.977	592	21,050
6 " " " ".....	20.0	9.762	755	16,220
8 " " " ".....	20.0	16.281	1,290	22,540
8 " " " ".....	26.8	16.141	1,645	17,570
8-inch channels, with 5/16-in. continuous plates.....	26.8	19.417	1,940	25,290
5/16-inch continuous plates and angles.. Width of plates, 12 in., 1 in. and 7.35 in.	26.8	16.168	1,765	28,020
7/16-inch continuous plates and angles.. Plates 12 in. wide.....	26.8	20.954	2,242	25,770
8-inch channels, latticed.....	13.3	7.628	679	33,910
8 " " " ".....	20.0	7.621	924	34,120
8 " " " ".....	26.8	7.673	1,255	29,870
8-inch channels, latticed, swelled sides..	13.4	7.624	684	33,530
8 " " " ".....	20.0	7.517	921	33,390
8 " " " ".....	26.8	7.702	1,280	30,770
10-inch channels, latticed, swelled sides.	16.8	11.944	1,470	33,740
10 " " " ".....	25.0	12.175	1,926	32,440
10 " " " ".....	16.7	12.366	1,549	31,130
10 " " " ".....	25.0	11.932	1,962	32,740
* 10-inch channels, latticed one side; con- tinuous plate one side.....	25.0	17.622	1,848	26,190
† 10-inch channels, latticed one side; con- tinuous plate one side.....	25.0	17.721	1,827	17,270

\* Pins in center of gravity of channel bars and continuous plate, 1.63 inches from center line of channel bars.

† Pins placed in center of gravity of channel bars.

### TENSILE TEST OF SIX STEEL EYE-BARS.

COMPARED WITH SMALL TEST INGOTS.

The steel was made by the Cambria Iron Company, and the eye-bar heads made by Keystone Bridge Company by upsetting and hammering. All the bars were made from one ingot. Two test pieces, 3/4-inch round, rolled from a test-ingot, gave elastic limit 48,040 and 42,210 pounds; tensile strength, 73,150 and 69,470 pounds, and elongation in 8 inches, 22.4 and 25.6 per cent respectively. The ingot from which the eye-bars were made was 14 inches square, rolled to billet, 7 × 6 inches. The eye-bars were rolled to 6 1/2 × 1 inch. Chemical tests gave carbon 0.27 to 0.30; manganese, 0.64 to 0.73; phosphorus, 0.074 to 0.098.

Gauged Length, inches.	Elastic limit, lbs. per sq. in.	Tensile strength per sq. in., lbs.	Elongation per cent, in Gauged Length.
160	37,480	67,800	15.8
160	36,650	64,000	6.96
160	.....	71,560	8.6
200	37,600	68,720	12.3
200	35,810	65,850	12.0
200	33,230	64,410	16.4
200	37,640	68,290	13.9

The average tensile strength of the 3/4-inch test pieces was 71,310 lbs., that of the eye-bars 67,230 lbs., a decrease of 5.7%. The average elastic limit of the test pieces was 45,150 lbs., that of the eye-bars 36,402 lbs., a decrease of 19.4%. The elastic limit of the test pieces was 63.3% of the ultimate strength, that of the eye-bars 54.2% of the ultimate strength.

Tests of 11 full-sized eye bars, 15 × 1 1/4 to 2 1/16 in., 20.5 to 21.4 ft. long between centers of pins, made by the Phoenix Iron Co., are reported in *Eng. News*, Feb. 2, 1905. The average T.S. of the bars was 58,300 lbs. per sq. in., E.L., 32,800. The average T.S. of small specimens was 63,900, E.L., 37,000. The T.S. of the full-sized bars averaged 8.8% and the E.L. 12.1% lower than the small specimens.

EFFECT OF COLD-DRAWING ON STEEL.

Three pieces cut from the same bar of hot-rolled steel:

1. Original bar, 2.03 in. diam., gauged length 30 in., tensile strength 55,400 lbs. per square in.; elongation 23.9%.
2. Diameter reduced in compression dies (one pass) .094 in.; T. S. 70,420; el. 2.7% in 20 in.
3. " " " " " " " 0.222 in.; T. S. 81,890; el. 0.075% in 20 in.

Compression test of cold-drawn bar (same as No. 3), length 4 in., diam. 1.808 in.: Compressive strength per sq. in., 75,000 lbs.; amount of compression 0.057 in.; set 0.04 in. Diameter increased by compression to 1.821 in. in the middle; to 1.813 in. at the ends.

MISCELLANEOUS TESTS OF IRON AND STEEL.

Tests of Cold-rolled and Cold-drawn Steel, made by the Cambria Iron Co. in 1897, gave the following results (averages of 12 tests of each):

	E. L.	T. S.	El. in 8 in.	Red.
Before cold-rolling.....	35,390	59,980	28.3%	58.5%
After cold-rolling.....	72,530	79,830	9.6%	34.9%
After cold-drawing.....	76,350	83,860	8.9%	34.2%

The original bars were 2 in. and 7/8 in. diameter. The test pieces cut from the bars were 3/4 in. diam., 18 in. long. The reduction in diameter from the hot-rolled to the cold-rolled or cold-drawn bar was 1/16 in. in each case.

**Cold Rolled Steel Shafting** (Jones & Laughlins) 1 11/16 in. diam. — Torsion tests of 12 samples gave apparent outside fiber stress, calculated from maximum twisting moment, 70,700 to 82,900 lbs. per sq. in.; fiber stress at elastic limit, 32,500 to 38,800 lbs. per sq. in.; shearing modulus of elasticity, 11,800,000 to 12,100,000; number of turns per foot before fracture, 1.60 to 2.06. — *Tech. Quar.*, vol. xii, Sept., 1899.

**Torsion Tests on Cold Rolled Shafting.** — (*Tech. Quar.* XIII, No. 3, 1900, p. 229.) 14 tests. Diameter about 1.69 in. Gauged length, 40 to 50 in. Outside fiber stress at elastic limit, 28,610 to 33,590 lbs. per sq. in.; apparent outside fiber stress at maximum load, 67,980 to 77,290. Shearing modulus of elasticity, 11,400,000 to 12,030,000 lbs. per sq. in. Turns per foot between jaws at fracture, 0.413 to 2.49.

**Torsion Tests on Refined Iron.** — 1 3/4 in. diam. 14 tests. Gauged length, 40 ins. Outside fiber stress at elastic limit, 12,790 to 19,140 lbs. per sq. in.; apparent outside fiber stress at maximum load, 45,350 to 58,340. Shearing modulus of elasticity, 10,220,000 to 11,700,000. Turns per foot between jaws at fracture, 1.08 to 1.42.

**Tests of Steel Angles with Riveted End Connections.** (F. P. McKibbin, *Proc. A.S.T.M.*, 1907.)—The angles broke through the rivet holes in all cases. The strength developed ranged from 62.5 to 79.1% of the ultimate strength of the gross area, or from 73.9 to 92% of the calculated strength of the net section at the rivet holes.

### SHEARING STRENGTH.

H. V. Loss in *American Engineer and Railroad Journal*, March and April, 1893, describes an extensive series of experiments on the shearing of iron and steel bars in shearing machines. Some of his results are:

Depth of penetration at point of maximum resistance for soft steel bars is independent of the width, but varies with the thickness. If  $d$  = depth of penetration and  $t$  = thickness,  $d = 0.3t$  for a flat knife,  $d = 0.25t$  for a 4° bevel knife, and  $d = 0.16\sqrt{t^3}$  for an 8° bevel knife. The ultimate pressure per inch of width in flat steel bars is approximately 50,000 lbs.  $\times t$ . The energy consumed in foot-pounds per inch width of steel bars is, approximately: 1" thick, 1300 ft.-lbs.; 1½", 2500; 1¾", 3700; 1⅞", 4500; the energy increasing at a slower rate than the square of the thickness. Iron angles require more energy than steel angles of the same size; steel breaks while iron has to be cut off. For hot-rolled steel the resistance per square inch for rectangular sections varies from 4400 lbs. to 20,500 lbs., depending partly upon its hardness and partly upon the size of its cross-area, which latter element indirectly but greatly indicates the temperature, as the smaller dimensions require a considerably longer time to reduce them down to size, which time again means loss of heat.

It is not probable that the resistance in practice can be brought very much below the lowest figures here given—viz., 4400 lbs. per square inch—as a decrease of 1000 lbs. will henceforth mean a considerable increase in cross-section and temperature.

**Relation of Shearing to Tensile Strength of Different Metals.** E. G. Izod, in a paper presented to the British Institution of Mechanical Engrs. (Jan., 1906), describes a series of tests on bars and plates of different metals. The specimens were firmly clamped on two steel plates with opposed shearing edges 4 ins. apart, and a shearing block, which was a sliding fit between these edges, was brought down upon the specimen, so as to cut it in double shear, by a testing machine.

	<i>a</i>	<i>b</i>	<i>c</i>		<i>a</i>	<i>b</i>	<i>c</i>
Cast iron. A.....	9.7	.....	152	Rolled phosphor-			
Cast iron. B.....	13.4	.....	111	bronze.....	39.5	11.7	61
Cast iron. C.....	11.3	.....	122	Aluminum.....	6.4	25.5	70
Cast aluminum-				Aluminum alloy.....	12.7	9.6	59
bronze.....	33.1	12.5	60	Wrought-iron bar..	26.0	22.5	75
Cast phosphor-				Mild-steel, 0.14 car-			
bronze.....	13.4	2.2	128	bon.....	26.9	34.7	78
Cast phosphor-				Crucible steel, 0.12 C	24.9	43.0	74
bronze.....	19.7	8.0	93	0.48 C.....	42.1	26.0	68
Gun metal.....	12.1	7.8	103	0.71 C.....	56.3	15.0	65
Yellow brass.....	7.5	6.5	126	0.77 C.....	61.3	11.0	62
Yellow brass.....	16.0	35.0	74				

*a*. Tensile strength of the metal, gross tons per sq. in.; *b*. elongation in 2 in.; *c*. ratio shearing  $\div$  tensile strength. The results seem to point to the fact that there is no common law connecting the ultimate shearing stress with the ultimate tensile stress, the ratio varying greatly with different materials. The test figures from crystalline materials, such as cast iron or those with very little or no elongation, seem to indicate that the ultimate shear stress exceeds the ultimate tensile stress by as much as 20 or 25%, while from those with a fairly high measure of ductility, the ultimate shear stress may be anything from 0 to 50% less than the ultimate tensile stress.

For shearing strength of rivets, see pages 240, 430 and 435.



## STRENGTH OF IRON AND STEEL PIPE.

**Tests of Strength and Threading of Wrought-Iron and Steel Pipe.** T. N. Thomson, in Proc. Am. Soc. Heat and Vent. Engineers, vol. xii., p. 80, describes some experiments on welded wrought iron and steel pipes. Short rings of 6-in. pipe were pulled in the direction of a diameter so as to elongate the ring. Four wrought iron rings broke at 2400, 3000, 3100 and 4100 lbs. and four steel rings at 5300 (defective weld) 18,000, 29,000 and 35,000 lbs. Another series of 9 tests each were tested so as to show the tensile strength of the metal and of the weld. The average strength of the metal was, iron, 34,520, steel, 61,850 lbs. The strength of the weld in iron ranged from 49 to 84, averaging 71 per cent of the strength of the metal, and in steel from 50 to 93, averaging 72%.

A large number of iron and steel pipes of different sizes were tested by twisting, the force being applied at the end of a three-foot lever. The average pull on the steel pipes was: 1/2 in. pipe, 109 lbs.; 1 in., 172 lbs.; 1 1/2 in., 300 lbs.; number of turns in 6 ft. length, respectively, 15, 8 and 5 1/2. Per cent failed in weld, 0, 13 and 13 respectively. For different lots of iron pipe the average pull was: 1/2 in., 68, 81 and 65 lbs.; 1 in., 154, 136, 107 lbs.; 1 1/2 in. 256, 250, 258 lbs. The number of turns in 6 feet for the nine lots were respectively, 4 1/2, 5 3/4, 2 1/2; 6 1/4, 3 1/2, 2 1/2; 4 1/2, 3 1/2, 2 1/4. The failures in the weld ranged from 33 to 100% in the different lots.

The force required to thread 1 1/4-in. pipe with two forms of die was tested by pulling on a lever 21 ins. long. The results were as follows:

Old form of die, iron pipe. . . . 83 to 87 lbs. pull, steel pipe 100 to 111 lbs.  
Improved die, iron pipe. . . . . 58 to 62 lbs. pull, steel pipe, 60 to 65 lbs.

Mr. Thomson gives the following table showing approximately the steady pull in pounds required at the end of a 16-in. lever to thread twist and split iron and steel pipe of small sizes:

	To Thread with Oiled Dies.			To Twist Lbs.	To Split Lbs.	Safety Margin Lbs.
	New Rake Dies.	New Common Dies.	Old Common Dies.			
1/2 in. steel.....	34	56	60	122	152	74
1/2 in. iron.....	27	33	49	102	110	46
3/4 in. steel.....	44	60	91	150	240	112
3/4 in. iron.....	44	51	73	140	176	81
1 in. steel.....	69	111	124	286	420	259
1 in. iron.....	62	106	116	273	327	173

The margin of safety is computed by adding 30% to the pull required to thread with the old dies and subtracting the sum from the pull required to split the pipe. If the mechanic pulls on the dies beyond the limit, due to imperfect dies, or to a hard spot in the pipe, he will split the pipe.

**Old Boiler Tubes used as Columns.** (*Tech. Quar.* XIII, No. 3, 1900, p. 225.) Thirteen tests were made of old 4-in. tubes taken from worn-out boilers. The lengths were from 6 to 8 ft., ratio  $l/r$  53 to 71, and thickness of metal 0.13 to 0.18 in. It is not stated whether the tubes were iron or steel. The maximum load ranged from 34,600 to 50,000 lbs., and the maximum load per sq. in. from 17,100 to 27,500 lbs. Six new tubes also were tested, with maximum loads 55,600 to 64,800 lbs., and maximum loads per sq. in. 31,600 to 38,100 lbs. The relation of the strength per sq. in. of the old tubes to the ratio  $l/r$  was very variable, being expressed approximately by the formula  $S = 41,000 - 300 l/r \pm 5000$ . That of the new tubes is approximately  $S = 52,000 - 300 l/r \pm 2000$ .

### HOLDING-POWER OF BOILER-TUBES EXPANDED INTO TUBE-SHEETS.

Experiments by Chief Engineer W. H. Shock, U. S. N., on brass tubes, 2½ inches diameter, expanded into plates ¾ inch thick, gave results ranging from 5850 to 46,000 lbs. Out of 48 tests 5 gave figures under 10,000 lbs., 12 between 10,000 and 20,000 lbs., 18 between 20,000 and 30,000 lbs., 10 between 30,000 and 40,000 lbs., and 3 over 40,000 lbs.

Experiments by Yarrow & Co., on steel tubes, 2 to 2¼ inches diameter, gave results similarly varying, ranging from 7900 to 41,715 lbs., the majority ranging from 20,000 to 30,000 lbs. In 15 experiments on 4 and 5 inch tubes the strain ranged from 20,720 to 68,040 lbs. Beading the tube does not necessarily give increased resistance, as some of the lower figures were obtained with beaded tubes. (See paper on Rules Governing the Construction of Steam Boilers, Trans. Engineering Congress, Section G, Chicago, 1893.)

#### The Slipping Point of Rolled Boiler-Tube Joints.

(O. P. Hood and G. L. Christensen, *Trans. A. S. M. E.*, 1908).

When a tube has started from its original seat, the fit may be no longer continuous at all points and a leak may result, although the ultimate holding power of the tube may not be impaired. A small movement of the tube under stress is then the preliminary to a possible leak, and it is of interest to know at what stress this slipping begins.

As results of a series of experiments with tube sheets of from ½ in. to 1 in. in thickness and with straight and tapered tube seats, the authors found that the slipping point of a 3-in. 12-gage Shelby cold-drawn tube rolled into a straight, smooth machined hole in a 1-in. sheet occurs with a pull of about 7,000 lbs. The frictional resistance of such tubes is about 750 lbs. per sq. in. of tube-bearing area in sheets ⅝ in. and 1 in. thick.

Various degrees of rolling do not greatly affect the point of initial slip, and for higher resistances to initial slip other resistance than friction must be depended upon. Cutting a 10-pitch square thread in the seat, about 0.01 in. deep will raise the slipping point to three or four times that in a smooth hole. In one test this thread was made 0.015 in. deep in a sheet 1 in. thick, giving an abutting area of about 1.4 sq. in., and a resistance to initial slip of 45,000 lbs. The elastic limit of the tube was reached at about 34,000 lbs.

Where tubes give trouble from slipping and are required to carry an unusual load, the slipping point can be easily raised by serrating the tube seat by rolling with an ordinary flue expander, the rolls of which are grooved about 0.007 in. deep and 10 grooves to the inch. One tube thus serrated had its slipping point raised between three and four times its usual value.

### METHODS OF TESTING THE HARDNESS OF METALS.

**Brinell's Method.** J. A. Brinell, a Swedish engineer, in 1900 published a method for determining the relative hardness of steel which has come into somewhat extensive use. A hardened steel ball, 10 mm. (0.3937 in.), is forced with a pressure of 3000 kg. (6614 lbs.) into a flat surface on the sample to be tested, so as to make a slight spherical indentation, the diameter of which may be measured by a microscope or the depth by a micrometer. The hardness is defined as the quotient of the pressure by the area of the indentation. From the measurement the "hardness number" is calculated by one of the following formulæ:

$$H = K (r + \sqrt{r^2 - R^2}) \div 2 \pi r R^2, \text{ or } H = K \div 2 \pi r d.$$

$K$  = load, = 3000 kg.,  $r$  = radius of ball, = 5 mm.,  $R$  = radius and  $d$  = depth of indentation.

The following table gives the hardness number corresponding to different values of  $R$  and  $d$ .

R	H	R	H	R	H	d	H	d	H	d	H
1.00	945	2.40	156	3.80	54.6	1.00	95.5	2.20	43.4	3.60	26.5
1.20	654	2.60	131	4.00	47.8	1.10	86.8	2.40	39.8	3.80	25.1
1.40	477	2.80	111	4.20	41.7	1.20	79.6	2.60	36.7	4.00	23.9
1.60	363	3.00	95.5	4.40	36.4	1.40	68.2	2.80	34.1	4.50	21.2
1.80	285	3.20	82.5	4.60	31.4	1.60	59.7	3.00	31.8	5.00	19.1
2.00	229	3.40	71.6	4.80	26.5	1.80	53.0	3.20	29.8	5.50	17.4
3.20	187	3.60	62.4	4.95	22.2	2.00	48.0	3.40	28.1	6.00	15.9

The hardness of steel, as determined by the Brinell method, has a direct relation to the tensile strength, and is equal to the product of a coefficient, *C*, into the hardness number. Experiments made in Sweden with annealed steel showed that when the impression was made transversely to the rolling direction, with *H* below 175, *C* = 0.362; with *H* above 175, *C* = 0.344. When the impression was made in the rolling direction, with *H* below 175, *C* = 0.354; with *H* above 175, *C* = 0.324. The product, *C* × *H*, or the tensile strength, is expressed in kilograms per square millimeter.

**Electro-magnetic Method.**—Several instruments have been devised for testing the hardness of steel by electrical methods. According to Prof. D. E. Hughes (*Cass. Mag.*, Sept., 1908), the magnetic capacity of iron and steel is directly proportional to the softness, and the resistance to a feeble external magnetic force is directly as the hardness. The electric conductivity of steel decreases with the increase of hardness. (See Electric Conductivity of Steel, p. 477.)

**The Scleroscope.**—This is the name of an instrument invented by A. F. Shore for determining the hardness of metals. It consists chiefly of a vertical glass tube in which slides freely a small cylinder of very hard steel, pointed on the lower end, called the hammer. This hammer is allowed to fall about 10 inches on to the sample to be tested, and the distance it rebounds is taken as a measure of the hardness of the sample. A scale on the tube is divided into 140 equal parts, and the hardness is expressed as the number on the scale to which the hammer rebounds. Measured in this way the hardness of different substances is as follows: Glass, 130; porcelain, 120; hardest steel, 110; tool steel, 1% C., may be as low as 31; mild steel, 0.5 C., 26 to 30; gray castings, 39; wrought iron, 18; babbitt metal, 4 to 10; soft brass, 12; zinc, 8; copper, 6; lead, 2. (*Cass. Mag.*, Sept., 1908.)

STRENGTH OF GLASS.

(Fairbairn's "Useful Information for Engineers," Second Series.)

	Best Flint Glass.	Common Green Glass.	Extra White Crown Glass.
Mean specific gravity . . . . .	3.078	2.528	2.450
Mean tensile strength, lbs. per sq. in., bars	2,413	2,896	2,546
do. thin plates	4,200	4,800	6,000
Mean crush'g strength, lbs. p. sq. in., cyl'drs	27,582	39,876	31,003
do. cubes	13,130	20,206	21,867

The bars in tensile tests were about 1/2 inch diameter. The crushing tests were made on cylinders about 3/4 inch diameter and from 1 to 2 inches high, and on cubes approximately 1 inch on a side. The mean transverse strength of glass, as calculated by Fairbairn from a mean tensile strength of 2560 lbs. and a mean compressive strength of 30,150 lbs. per sq. in., is, for a bar supported at the ends and loaded in the middle,  $w = 3140 bd^2/l$ , in which *w* = breaking weight in lbs., *b* = breadth, *d* = depth, and *l* = length, in inches. Actual tests will probably show wide variations in both directions from the mean calculated strength.



## STRENGTH OF ICE.

Experiments at the University of Illinois in 1895 (*The Technograph*, vol. ix) gave 620 lbs. per sq. in. as the average crushing strength of cubes of manufactured ice tested at 23° F., and 906 lbs. for cubes tested at 14° F. Natural ice, at 12° F., tested with the direction of pressure parallel to the original water surface, gave a mean of 1070 lbs., and tested with the pressure perpendicular to this surface 1845 lbs. The range of variation in strength of individual pieces is about 50% above and below the mean figures, the lowest and highest figures being respectively 318 and 2818 lbs. per sq. in. The tensile strength of 34 samples tested at 19 to 23° F. was from 102 to 256 lbs. per sq. in.

## STRENGTH OF TIMBER.

**Strength of Long-leaf Pine** (Yellow Pine, *Pinus Palustris*) from Alabama (Bulletin No. 8, Forestry Div., Dept. of Agriculture, 1893. Tests by Prof. J. B. Johnson).

The following is a condensed table of the range of results of mechanical tests of over 2000 specimens, from 26 trees from four different sites in Alabama; reduced to 15 per cent moisture:

	Butt Logs.	Middle Logs.	Top Logs.	Av'g of all Butt Logs.
Specific gravity.....	0.449 to 1.039	0.575 to 0.859	0.484 to 0.907	0.767
Transverse strength, $\frac{3WL}{2bh^2}$	4,762 to 16,200	7,640 to 17,128	4,268 to 15,554	12,614
do. do. at elast. limit	4,930 to 13,110	5,540 to 11,790	2,553 to 11,950	9,460
Mod. of elast., thous. lbs.	1,119 to 3,117	1,136 to 2,982	842 to 2,697	1,926
Relative elast. resilience, inch-pounds per cub. in.	0.23 to 4.69	1.34 to 4.21	0.09 to 4.65	2.98
Crushing endwise, str. per sq. in.-lbs.....	4,781 to 9,850	5,030 to 9,300	4,587 to 9,100	7,452
Crushing across grain, strength per sq. in., lbs.	675 to 2,094	656 to 1,445	584 to 1,766	1,598
Tensile strength per sq. in.....	8,600 to 31,890	6,330 to 29,500	4,170 to 23,280	17,359
Shearing strength (with grain), mean per sq. in.	464 to 1,299	539 to 1,230	484 to 1,156	866

Some of the deductions from the tests were as follows:

1. With the exception of tensile strength a reduction of moisture is accompanied by an increase in strength, stiffness, and toughness.  
2. Variation in strength goes generally hand-in-hand with specific gravity.

3. In the first 20 or 30 feet in height the values remain constant; then occurs a decrease of strength which amounts at 70 feet to 20 to 40 per cent of that of the butt-log.

4. In shearing parallel with the grain and crushing across and parallel with the grain, practically no difference was found.

5. Large beams appear 10 to 20 per cent weaker than small pieces.

6. Compression tests endwise seem to furnish the best average statement of the value of wood, and if one test only can be made, this is the safest, as was also recognized by Bauschinger.

7. Bled timber is in no respect inferior to unbled timber.

The figures for crushing across the grain represent the load required to cause a compression of 15 per cent. The relative elastic resilience, in inch-pounds per cubic inch of the material, is obtained by measuring the area of the plotted strain-diagram of the transverse test from the origin to the point in the curve at which the rate of deflection is 50 per cent greater than the rate in the earlier part of the test where the diagram is a straight line. This point is arbitrarily chosen since there is no definite "elastic limit" in timber as there is in iron. The "strength at the elastic limit" is the strength taken at this same point. Timber is not perfectly elastic for any load if left on any great length of time.

The long-leaf pine is found in all the Southern coast states from North



Carolina to Texas. Prof. Johnson says it is probably the strongest timber in large sizes to be had in the United States. In small selected specimens, other species, as oak and hickory, may exceed it in strength and toughness. The other Southern yellow pines, viz., the Cuban, short-leaf and the loblolly pines are inferior to the long-leaf about in the ratios of their specific gravities; the long-leaf being the heaviest of all the pines. It averages (kiln-dried) 48 pounds per cubic foot, the Cuban 47, the short-leaf 40, and the loblolly 34 pounds.

**Strength of Spruce Timber.**—The modulus of rupture of spruce is given as follows by different authors: Hatfield, 9900 lbs. per square inch; Rankine, 11,100; Laslett, 9045; Trautwine, 8100; Rodman, 6168. Trautwine advises for use to deduct one-third in the case of knotty and poor timber.

Prof. Lanza, in 25 tests of large spruce beams, found a modulus of rupture from 2995 to 5666 lbs.; the average being 4613 lbs. These were average beams, ordered from dealers of good repute. Two beams of selected stock, seasoned four years, gave 7562 and 8748 lbs. The modulus of elasticity ranged from 897,000 to 1,588,000, averaging 1,294,000.

Time tests show much smaller values for both modulus of rupture and modulus of elasticity. A beam tested to 5800 lbs. in a screw machine was left over night, and the resistance was found next morning to have dropped to about 3000, and it broke at 3500.

Prof. Lanza remarks that while it was necessary to use larger factors of safety, when the moduli of rupture were determined from tests with smaller pieces, it will be sufficient for most timber constructions, except in factories, to use a factor of four. For breaking strains of beams, he states that it is better engineering to determine as the safe load of a timber beam the load that will not deflect it more than a certain fraction of its span, say about  $\frac{1}{300}$  to  $\frac{1}{400}$  of its length.

**Expansion of Timber Due to the Absorption of Water.**

(De Volson Wood, A. S. M. E., vol. x.)

Pieces 36 × 5 in., of pine, oak, and chestnut, were dried thoroughly, and then immersed in water for 37 days.

The mean per cent of elongation and lateral expansion were:

	Pine.	Oak.	Chestnut.
Elongation, per cent . . . . .	0.065	0.085	0.165
Lateral expansion, per cent . . . .	2.6	3.5	3.65

**Expansion of Wood by Heat.**—Trautwine gives for the expansion, of white pine for 1 degree Fahr. 1 part in 440,530, or for 180 degrees 1 part in 2447, or about one-third of the expansion of iron.

**Shearing Strength of American Woods, adapted for Pins or Tree-nails.**

J. C. Trautwine (*Jour. Franklin Inst.*). (Shearing across the grain.)

	per sq. in.		per sq. in.
Ash . . . . .	6280	Hickory . . . . .	6045
Beech . . . . .	5223	Hickory . . . . .	7285
Birch . . . . .	5595	Maple . . . . .	6355
Cedar (white) . . . . .	1372	Oak . . . . .	4425
Cedar (white) . . . . .	1519	Oak (live) . . . . .	8480
Cedar (Central American) . . . .	3410	Pine (white) . . . . .	2480
Cherry . . . . .	2945	Pine (Northern yellow) . . . . .	4340
Chestnut . . . . .	1536	Pine (Southern yellow) . . . . .	5735
Dogwood . . . . .	6510	Pine (very resinous yellow) . . .	5053
Ebony . . . . .	7750	Poplar . . . . .	4418
Gum . . . . .	5890	Spruce . . . . .	3255
Hemlock . . . . .	2750	Walnut (black) . . . . .	4728
Locust . . . . .	7176	Walnut (common) . . . . .	2830

**Transverse Tests of Pine and Spruce Beams.** (*Tech. Quar.* XIII, No. 3, 1900, p. 226.)—Tests of 37 hard pine beams, 4 to 10 ins. wide, 6 to 12 ins. deep, and 8 to 16 ft. length between supports, showed great varia-

tions in strength. The modulus of rupture of different beams was as follows: 1, 2970; 4, 4000 to 5000; 1, 5510; 1, 6220; 9, 7000 to 8000; 8, 8000 to 9000; 4, 9000 to 10,000; 5, 10,000 to 11,000; 3, 11,000 to 12,000; 1, 13,600.

Six tests of white pine beams gave moduli of rupture ranging from 1840 to 7810; and eighteen tests of spruce beams from 2750 to 7970 lbs. per sq. in.

**Drying of Wood.**—Circular 111, U. S. Forest Service, 1907. Sticks of Southern loblolly pine 11 to 13 inches diameter, 9 to 10 ft. long, were weighed every two weeks until seasoned, to find the weight of water evaporated. The loss, per cent of weight, was as follows:

Weeks.....	2	4	6	8	10	12	14	16
Loss per cent of green wood.....	16	21	26	31	32	34	35	35

**Preservation of Timber.**—U. S. Forest Service, Circular 111, 1907, discusses preservative treatment of timber by different methods, namely, brush treatment with creosote and with carbolinum; open tank treatment with salt solution, zinc chloride solution; and cylinder treatment with zinc chloride solution and creosote.

The increased life necessary to pay the cost of these several preservative treatments is respectively: 6, 16, 7, 13, 41, 27, and 55%. The results of the experiments prove that it will pay mining companies to peel their timber, to season it for several months and to treat it with a good preservative. Loblolly and pitch pine have been most successfully preserved by treatment with creosote in an open tank.

Circular No. 151 of the Forest Service describes experiments on the best method of treating loblolly pine cross-arms of telegraph poles. The arms after being seasoned in air are placed in a closed air-tight cylinder, a vacuum is applied sufficient to draw the oil (creosote, dead oil of coal tar) from the storage tank into the treating cylinder. Sufficient pressure is then applied to force the oil into the heartwood portion of the timber, and continued until the desired amount of oil is absorbed, then a vacuum is maintained until the surplus oil is drawn from the sapwood. It is recommended that heartwood should finally contain about 6 lbs. of oil per cubic foot, and sapwood about 10 lbs. The preliminary bath of live steam, formerly used, has been found unnecessary. Much valuable information concerning timber treatment and its benefits is contained in the several circulars on the subject issued by the Forest Service.

### STRENGTH OF COPPER AT HIGH TEMPERATURES.

The British Admiralty conducted some experiments at Portsmouth Dockyard in 1877, on the effect of increase of temperature on the tensile strength of copper and various bronzes. The copper experimented upon was in rods 0.72 in. diameter.

The following table shows some of the results:

Temperature, Fahr.	Tensile Strength in lbs. per sq. in.	Temperature, Fahr.	Tensile Strength in lbs. per sq. in.
Atmospheric	23,115	300°	21,607
100°	23,366	400°	21,105
200°	22,110	500°	19,597

Up to a temperature of 400° F. the loss of strength was only about 10 per cent, and at 500° F. the loss was 16 per cent. The temperature of steam at 200 lbs. pressure is 382° F., so that according to these experiments the loss of strength at this point would not be a serious matter. Above a temperature of 500° the strength is seriously affected.

### COPPER CASTINGS OF HIGH CONDUCTIVITY.

A method of making copper castings of high electric conductivity is described in *The Foundry*, Sept., 1910. The copper is melted under a cover of charcoal and common salt. When thoroughly liquid, 2 oz. of stick magnesium is added per 100 lb. of copper, being plunged below the surface of the copper and held there until reaction ceases. The metal should be stirred for five minutes with a plumbago stirrer, and reheated before pouring. The castings have a conductivity of about 85% if high grade ingot copper is used.

## TESTS OF AMERICAN WOODS. (Watertown Arsenal Tests, 1883.)

In all cases a large number of tests were made of each wood. Minimum and maximum results only are given. All of the test specimens had a sectional area of  $1.575 \times 1.575$  inches. The transverse test specimens were 39.37 inches between supports, and the compressive test specimens were 12.60 inches long. Modulus of rupture calculated from

formula  $R = \frac{3 Pl}{2 bd^2}$ ;  $P$  = load in pounds at the middle,  $l$  = length, in inches,  $b$  = breadth,  $d$  = depth:

Name of Wood.	Transverse Tests. Modulus of Rupture.		Compression Parallel to Grain, pounds per square inch.	
	Min.	Max.	Min.	Max.
Cucumber tree ( <i>Magnolia acuminata</i> ) . . . . .	7,440	12,050	4,560	7,410
Yellow poplar white wood ( <i>Liriodendron tulipifera</i> ) . . . . .	6,560	11,756	4,150	5,790
White wood, Basswood ( <i>Tilia Americana</i> ) . . . . .	6,720	11,530	3,810	6,480
Sugar-maple, Rock-maple ( <i>Acer saccharinum</i> ) . . . . .	9,680	20,130	7,460	9,940
Red maple ( <i>Acer rubrum</i> ) . . . . .	8,610	13,450	6,010	7,500
Locust ( <i>Robinia pseudacacia</i> ) . . . . .	12,200	21,730	8,330	11,940
Wild cherry ( <i>Prunus serotina</i> ) . . . . .	8,310	16,800	5,830	9,120
Sweet gum ( <i>Liquidambar styraciflua</i> ) . . . . .	7,470	11,130	5,630	7,620
Dogwood ( <i>Cornus florida</i> ) . . . . .	10,190	14,560	6,250	9,400
Sour gum, Pepperidge ( <i>Nyssa sylvatica</i> ) . . . . .	9,830	14,300	6,240	7,480
Persimmon ( <i>Diospyros Virginiana</i> ) . . . . .	10,290	18,500	6,650	8,080
White ash ( <i>Fraxinus Americana</i> ) . . . . .	5,950	15,800	4,520	8,830
Sassafras ( <i>Sassafras officinale</i> ) . . . . .	5,180	10,150	4,050	5,970
Slippery elm ( <i>Ulmus fulva</i> ) . . . . .	10,220	13,952	6,980	8,790
White elm ( <i>Ulmus Americana</i> ) . . . . .	8,250	15,070	4,960	8,040
Sycamore; Buttonwood ( <i>Platanus occidentalis</i> ) . . . . .	6,720	11,360	4,960	7,340
Butternut; white walnut ( <i>Juglans cinerea</i> ) . . . . .	4,700	11,740	5,480	6,810
Black walnut ( <i>Juglans nigra</i> ) . . . . .	8,400	16,320	6,940	8,850
Shellbark hickory ( <i>Carya alba</i> ) . . . . .	14,870	20,710	7,650	10,280
Pignut ( <i>Carya porcina</i> ) . . . . .	11,560	19,430	7,460	8,470
White oak ( <i>Quercus alba</i> ) . . . . .	7,010	18,360	5,810	9,070
Red oak ( <i>Quercus rubra</i> ) . . . . .	9,760	18,370	4,960	8,970
Black oak ( <i>Quercus tinctoria</i> ) . . . . .	7,900	18,420	4,540	8,550
Chestnut ( <i>Castanea vulgaris</i> ) . . . . .	5,950	12,870	3,680	6,650
Beech ( <i>Fagus ferruginea</i> ) . . . . .	13,850	18,840	5,770	7,840
Canoe-birch, paper-birch ( <i>Betula papyracea</i> ) . . . . .	11,710	17,610	5,770	8,590
Cottonwood ( <i>Populus monilifera</i> ) . . . . .	8,390	13,430	3,790	6,510
White cedar ( <i>Thuja occidentalis</i> ) . . . . .	6,310	9,530	2,660	5,810
Red cedar ( <i>Juniperus Virginiana</i> ) . . . . .	5,640	15,100	4,400	7,040
Cypress ( <i>Saxodium Distichum</i> ) . . . . .	9,530	10,030	5,060	7,140
White pine ( <i>Pinus strobus</i> ) . . . . .	5,610	11,530	3,750	5,600
Spruce pine ( <i>Pinus glabra</i> ) . . . . .	3,780	10,980	2,580	4,680
Long-leaved pine, Southern pine ( <i>Pinus palustris</i> ) . . . . .	9,220	21,060	4,010	10,600
White spruce ( <i>Picea alba</i> ) . . . . .	9,900	11,650	4,150	5,300
Hemlock ( <i>Tsuga Canadensis</i> ) . . . . .	7,590	14,680	4,500	7,420
Red fir, yellow fir ( <i>Pseudotsuga Douglasii</i> ) . . . . .	8,220	17,920	4,880	9,800
Tamarack ( <i>Larix Americana</i> ) . . . . .	10,080	16,770	6,810	10,700



## TENSILE STRENGTH OF ROLLED ZINC PLATES.

Herbert F. Moore, in *Univ. of Ill. Bulletin*, No. 9, 1911, gives a table from which the following averages are taken:

Thickness, In.	Tensile Strength, Lb. per Sq. In.		Elongation in 8 In., %.	
	with grain.	across grain.	with grain.	across grain.
1.	21340	23050	4.85	0.31
0.6	21490	23550	16.63	3.33
0.25	23770	22260	11.90	0.27
0.10	23580	33620	20.4	14.3
0.018	24660	32380	.....	.....

## THE STRENGTH OF BRICK, STONE, ETC.

A great advance has recently (1895) been made in the manufacture of brick, in the direction of increasing their strength. Chas. P. Chase, in *Engineering News*, says: "Taking the tests as given in standard engineering books eight or ten years ago, we find in Trautwine the strength of brick given as 500 to 4200 lbs. per sq. in. Now, taking recent tests in experiments made at Watertown Arsenal, the strength ran from 5000 to 22,000 lbs. per sq. in. In the tests on Illinois paving-brick, by Prof. I. O. Baker, we find an average strength in hard paving brick of over 5000 lbs. per square inch. The average crushing strength of ten varieties of paving-brick much used in the West, I find to be 7150 lbs. to the square inch."

A test of brick made by the dry-clay process at Watertown Arsenal, according to *Paving*, showed an average compressive strength of 3972 lbs. per sq. in. In one instance it reached 4973 lbs. per sq. in. A test was made at the same place on a "fancy pressed brick." The first crack developed at a pressure of 305,000 lbs., and the brick crushed at 364,300 lbs., or 11,130 lbs. per sq. in. This indicates almost as great compressive strength as granite paving-blocks, which is from 12,000 to 20,000 lbs. per sq. in.

The three following notes on bricks are from Trautwine's *Engineer's Pocket-book*:

**Strength of Brick.** — 40 to 300 tons per sq. ft., 622 to 4668 lbs. per sq. in. A soft brick will crush under 450 to 600 lbs. per sq. in., or 30 to 40 tons per square foot, but a first-rate machine-pressed brick will stand 200 to 400 tons per sq. ft. (3112 to 6224 lbs. per sq. in.).

**Weight of Bricks.** — Per cubic foot, best pressed brick, 150 lbs.; good pressed brick, 131 lbs.; common hard brick, 125 lbs.; good common brick, 118 lbs.; soft inferior brick, 100 lbs.

**Absorption of Water.** — A brick will in a few minutes absorb  $\frac{1}{2}$  to  $\frac{3}{4}$  lb. of water, the last being  $\frac{1}{7}$  of the weight of a hand-molded one, or  $\frac{1}{3}$  of its bulk.

**Strength of Common Red Brick.** — Tests of 67 samples of Hudson River machine-molded brick were made by I. H. Woolson, *Eng. News*, April 13, 1905. The crushing strength, in lbs. per sq. in., of 15 pale brick ranged from 1607 to 4546, average 3010; 44 medium, 2080 to 8944, av. 4080; 8 hard brick, 2396 to 6420, av. 4960. Five Philadelphia pressed brick gave from 3524 to 9425, av. 6361. The absorption ranged from 8.7 to 21.4% by weight. The relation of absorption to strength varied greatly, but on the average there was an increase of absorption up to 3000 lbs. per sq. in. crushing strength, and beyond that a decrease.

**The Strongest Brick** ever tested at the Watertown Arsenal was a paving brick from St. Louis, Mo., which showed a compressive strength of 38,446 lbs. per sq. in. The absorption was 0.21% by weight and 0.5% by volume. The sample was set on end, and measured 2.45 × 3.06 ins. in cross section. — *Eng. News*, Mar. 14, 1907.

**Tests of Bricks, full size, on flat side.** (Tests made at Watertown, Arsenal in 1883.) — The bricks were tested between flat steel buttresses. Compressed surfaces (the largest surface) ground approximately flat. The bricks were all about 2 to 2.1 inches thick, 7.5 to 8.1 inches long, and 3.5 to 3.76 inches wide. Crushing strength per square inch: One lot ranged from 11,056 to 16,734 lbs.; a second, 12,995 to 22,351; a



third, 10,390 to 12,709. Other tests gave results from 5960 to 10,250 lbs. per sq. in.

**Tests of Brick.** (*Tech. Quar.*, 1900.) — Different brands of brick tested on the broad surfaces, and on edge, gave results as follows, lbs. per sq. in.

(*Tech. Quar.* XII, No. 3, 1899.) 38 tests.

	No. Test.	Average.	Maximum.	Minimum.	Per cent Water Absorbed.
On broad surface					
Bay State, light hard	71	7039	11,240	3587	15.15 to 19.3 av. 7.5
Same, tested on edge	67	6241	10,840	3325	13.67 to 18.2 " 7.4
On broad surface					
Dover River, soft burned.....	38	5350	8630	3930	14.0 to 18.6 " 11.6
Dover River, hard burned.....	36	8070	10,940	5850	4.7 to 10.1 " 7.0
Central N. Y., soft burned.....	36	2190	3060	1370	17.8 to 22.0 " 19.9
Central N. Y., medium burned.....	36	3600	4950	2080	16.6 to 23.4 " 18.6
Central N. Y., hard burned.....	36	5360	8810	3310	8.3 to 16.7 " 12.5
Another lot,* hard burned.....	16	7940	9770	6570	7.6 to 12.9 " 10.6
Same,* tested on edge	16	6430	10,230	3830	6.2 to 18.7 " 11.4

\* Brand not named.

The per cent water absorbed in general seemed to have a relation to the strength, the greatest absorption corresponding to the lowest strength, and *vice versa*, but there were many exceptions to the rule.

**Crushing Strength of Masonry Materials.** (From Howe's "Retaining-Walls.") —

	tons per sq. ft.		tons per sq. ft.
Brick, best pressed .	40 to 300	Limestones and marbles	250 to 1000
Chalk.....	20 to 30	Sandstone.....	150 to 550
Granite.....	300 to 1200	Soapstone.....	400 to 800

**Strength of Granite.** — The crushing strength of granite is commonly rated at 12,000 to 15,000 lbs. per sq. in. when tested in two-inch cubes, and only the hardest and toughest of the commonly used varieties reach a strength above 20,000 lbs. Samples of granite from a quarry on the Connecticut River, tested at the Watertown Arsenal, have shown a strength of 35,965 lbs. per sq. in. (*Engineering News*, Jan. 12, 1893).

Ordinary granite ranges from 20,000 to 30,000 lbs. compressive strength per sq. in. A granite from Asheville, N.C., tested at the Watertown Arsenal, gave 51,900 lbs. — *Eng. News*, Mar. 14, 1907.

**Strength of Avondale, Pa., Limestone.** (*Engineering News*, Feb. 9, 1893.) — Crushing strength of 2-in. cubes: light stone 12,112, gray stone 18,040, lbs. per sq. in.

Transverse test of lintels, tool-dressed, 42 in. between knife-edge bearings, load with knife-edge brought upon the middle between bearings:

Gray stone, section 6 in. wide X 10 in. high, broke under a load of 20,950 lbs.	
Modulus of rupture .....	2,200 "
Light stone, section 8¼ in. wide X 10 in. high, broke under...	14,720 "
Modulus of rupture .....	1,170 "
Absorption. — Gray stone .....	0.051 of 1%
Light stone.....	0.052 of 1%

**Tests of Sand-lime Brick.** (I. H. Woolson, *Eng. News*, June 14, 1906). — Eight varieties of brick in lots of 300 to 800 were received from different manufacturers. They were tested for transverse strength, on supports 7 in. apart, loaded in the middle: and half bricks were tested by

compression, sheets of heavy fibrous paper being inserted between the specimen and the plates of the testing machine to insure an even bearing. Tests were made on the brick as received, and on other samples after drying at about 150° F. to constant weight, requiring from four to six days. The moisture in two bricks of each series was determined, and found to range from 1 to 10%, average 5.9%. The figures of results given below are the averages of 10 tests in each case. Other bricks of each lot were tested for absorption by being immersed  $\frac{1}{2}$  in. in water for 48 hours, for resistance to 20 repeated freezings and thawings, and for resistance to fire by heating them in a fire testing room, the bricks being built in as 8-in. walls, to 1700° F. and maintaining that temperature three hours, then cooling them with a  $1\frac{1}{8}$ -in. stream of cold water from a hydrant. Transverse and compressive tests were made after these treatments. The results given below are averages of five tests, except in the case of the bricks tested after firing, in which two samples are averaged.

**EFFECT OF THE FIRE TEST.** — Several large cracks developed in both the sand-lime and the clay brick walls during the test. These were no worse in one wall than in the other. With the exception of surface deterioration the walls were solid and in good condition. After they were cooled the inside course of each wall was cut through and specimens of each series secured for examination and test. It was difficult to secure whole bricks, owing to the extreme brittleness.

In general the bricks were affected by fire about half way through. They were all brittle and many of them tender when removed from the wall. With the sand-lime brick, if a brick broke the remainder had to be chiseled out like concrete, whereas a clay brick under like conditions would chip out easily. The clay brick were so brittle and full of cracks that the wall could be broken down without trouble. The sand-lime bricks adhered to the mortar better, were cracked less, and were not so brittle.

Designation of Brick.		A	B	C	D	E	F	G
Modulus of Rupture	As received	272	424	377	262	190	301	365
	Dried	320	505	406	334	197	570	494
	Increase, %	15.0	16.0	7.1	21.5	3.5	47.2	26.2
	Wet	248	349	345	241	243	250	485
	After fire	17	57	20	32	24	27	37
Compressive Strength, lbs. per sq. in.	As received	1875	2300	2871	1923	1610	2460	2669
	Dried	2604	2772	3240	2476	1870	3273	3190
	Increase, %	30.2	17.1	20.7	22.3	13.5	24.8	16.3
	Wet	1611	2174	2097	1923	1108	2063	2183
	After freez- ing	1596	1619	2265	1174	1167	1851	1739
After fire	1807	2814	2573	2069	1089	2051	4885	
% of lime in brick	6	10	5	4 $\frac{1}{2}$	4 $\frac{1}{2}$	5	8	
Pressure for hardening, lbs.	120	135	150	125	120	150	125	
Hours in hardening, lbs.	10	8	7	10	10	7	10	

### STRENGTH OF LIME AND CEMENT MORTAR.

(Engineering. October 2, 1891.)

Tests made at the University of Illinois on the effects of adding cement to lime mortar. In all the tests a good quality of ordinary fat lime was used, slaked for two days in an earthenware jar, adding two parts by weight of water to one of lime, the loss by evaporation being made up by fresh additions of water. The cements used were a German Portland, Black Diamond (Louisville), and Rosendale. As regards fineness of grinding, 85 per cent of the Portland passed through a No. 100 sieve, as did 72 per cent of the Rosendale. A fairly sharp sand, thoroughly washed and dried, passing through a No. 18 sieve and caught on a No. 30,

was used. The mortar in all cases consisted of two volumes of sand to one of lime paste. The following results were obtained on adding various percentages of cement to the mortar:

**Tensile Strength, pounds per square inch.**

Age.....	4 Days.	7 Days.	14 Days.	21 Days.	28 Days.	50 Days.	84 Days.
Lime mortar.....	4	8	10	13	18	21	26
20 per cent Rosendale	5	8 1/2	9 1/2	12	17	17	18
20 " " Portland.	5	8 1/2	14	20	25	24	26
30 " " Rosendale	7	11	13	18 1/2	21	22 1/2	23
30 " " Portland.	8	16	18	22	25	28	27
40 " " Rosendale	10	12	16 1/2	21 1/2	22 1/2	24	36
40 " " Portland.	27	39	38	43	47	59	57
60 " " Rosendale	9	13	20	16	22	22 1/2	23
60 " " Portland.	45	58	55	68	67	102	78
80 " " Rosendale	12	18 1/2	22 1/2	27	29	31 1/2	33
80 " " Portland.	87	91	103	124	94	210	145
100 " " Rosendale	18	23	26	31	34	46	48
100 " " Portland.	90	120	146	152	181	205	202

**Tests of Portland Cement.**

(Tech. Quar. XIII. No. 3, 1900, p. 236.)

	1 Day.	2 Days.	14 Days	1 Mo.	2 Mos.	6 Mos.	1 Year.
Neat cement: .							
Tension, lbs. per sq. in...	268-312	454-532	780-820	915-920	950-1100	1036-1190	996-1248
Compression, lbs. per sq. in	{ 8650	{ 13,080	{ 23,640	{ .....	{ 34,000	{ .....	{ 36,150
	{ to	{ to	{ to	{ .....	{ to	{ .....	{ to
	{ 10,250	{ 14,860	{ 34,820	{ .....	{ 38,500	{ .....	{ 50,000
3 sand, 1 cem. Tens.....	56-75	79-92	185-211	211-230	217-240	300-382	280-383
3 sand, 1 cem. Comp	{ 1200	{ 1750	{ 3780	{ .....	{ 7850	{ .....	{ 8000
	{ to	{ to	{ to	{ .....	{ to	{ .....	{ to
	{ 1585	{ 1885	{ 4420	{ .....	{ 8250	{ .....	{ 10,000

**TRANSVERSE STRENGTH OF FLAGGING.**

(N. J. Steel & Iron Co.'s Book.)

EXPERIMENTS MADE BY R. G. HATFIELD AND OTHERS.

*b* = width of the stone in inches; *d* = its thickness in inches; *l* = distance between bearings in inches.

The *breaking loads* in tons of 2000 lbs., for a weight placed at the *center* of the space, will be as follows:

	$\frac{bd^2}{l} \times$	$\frac{bd^2}{l} \times$
Bluestone flagging.....	0.744	Dorchester freestone..... 0.264
Quincy granite.....	0.624	Aubigny freestone..... 0.216
Little Falls freestone.....	0.576	Caen freestone..... 0.144
Belleville, N. J., freestone... 0.480		Glass..... 1.000
Granite (another quarry)... 0.432		Slate..... 1.2 to 2.7
Connecticut freestone..... 0.312		

Thus a block of Quincy granite 80 inches wide and 6 inches thick, resting on beams 36 inches in the clear, would be broken by a load resting midway between the beams =  $\frac{80 \times 36}{36} \times 0.624 = 49.92$  tons.

**MODULI OF ELASTICITY OF VARIOUS MATERIALS.**

The modulus of elasticity determined from a tensile test of a bar of any material is the quotient obtained by dividing the tensile stress in pounds per square inch at any point of the test by the elongation per inch of length produced by that stress; or if  $P$  = pounds of stress applied,  $K$  = the sectional area,  $l$  = length of the portion of the bar in which the measurement is made, and  $\lambda$  = the elongation in that length, the modulus of elasticity  $E = \frac{P}{K} \div \frac{\lambda}{l} = \frac{Pl}{K\lambda}$ . The modulus is generally measured within the elastic limit only, in materials that have a well-defined elastic limit, such as iron and steel, and when not otherwise stated the modulus is understood to be the modulus within the elastic limit. Within this limit, for such materials the modulus is practically constant for any given bar, the elongation being directly proportional to the stress. In other materials, such as cast iron, which have no well-defined elastic limit, the elongations from the beginning of a test increase in a greater ratio than the stresses, and the modulus is therefore at its maximum near the beginning of the test, and continually decreases. The moduli of elasticity of various materials have already been given above in treating of these materials, but the following table gives some additional values selected from different sources:

Brass, cast.....	9,170,000	
Brass wire.....	14,230,000	
Copper.....	15,000,000 to 18,000,000	
Lead.....	1,000,000	
Tin, cast.....	4,600,000	
Iron, cast.....	12,000,000 to 27,000,000 (?)	
Iron, wrought.....	22,000,000 to 29,000,000 (?)	
Steel.....	28,000,000 to 32,000,000 (see below)	
Marble.....	25,000,000	
Slate.....	14,500,000	
Glass.....	8,000,000	
Ash.....	1,600,000	
Beech.....	1,300,000	
Birch.....	1,250,000 to 1,500,000	
Fir.....	869,000 to 2,191,000	
Oak.....	974,000 to 2,283,000	
Teak.....	2,414,000	
Walnut.....	306,000	
Pine, long-leaf (butt-logs).....	1,119,000 to 3,117,000	Avg. 1,926,900

The maximum figures given by some early writers for iron and steel, viz., 40,000,000 and 42,000,000, are undoubtedly erroneous. The modulus of elasticity of steel (within the elastic limit) is remarkably constant, notwithstanding great variations in chemical analysis, temper, etc. It rarely is found below 29,000,000 or above 31,000,000. It is generally taken at 30,000,000 in engineering calculations. Prof. J. B. Johnson, in his report on Long-leaf Pine, 1893, says: "The modulus of elasticity is the most constant and reliable property of all engineering materials. The wide range of value of the modulus of elasticity of the various metals found in public records must be explained by erroneous methods of testing."

In a tensile test of cast iron by the author (Van Nostrand's Science Series, No. 41, page 45), in which the ultimate strength was 23,285 lbs. per sq. in., the measurements of elongation were made to 0.0001 inch, and the modulus of elasticity was found to decrease from the beginning of the test, as follows: At 1000 lbs. per sq. in., 25,000,000; at 2000 lbs., 16,666,000; at 4000 lbs., 15,384,000; at 6000 lbs., 13,636,000; at 8000 lbs., 12,500,000; at 12,000 lbs., 11,250,000; at 15,000 lbs., 10,000,000; at 20,000 lbs., 8,000,000; at 23,000 lbs., 6,140,000.

**FACTORS OF SAFETY.**

A factor of safety is the ratio in which the load that is just sufficient to overcome instantly the strength of a piece of material is greater than the greatest safe ordinary working load. (Rankine.)

Rankine gives the following "examples of the values of those factors which occur in machines":



	Dead Load.	Live Load, Greatest.	Live Load, Mean.
Iron and steel.....	3	6	from 6 to 40
Timber.....	4 to 5	8 to 10	.....
Masonry.....	4	8	.....

The great factor of safety, 40, is for shafts in millwork which transmit very variable efforts.

Unwin gives the following "factors of safety which have been adopted in certain cases for different materials." They "include an allowance for ordinary contingencies."

Material.	A Varying Load Producing			
	Actual Load	Stress of One Kind only.	Equal Alternate Stresses of different kinds.	In Structures subj. to varying Loads and Shocks
Cast iron.....	4	6	10	15
Wrought iron and steel	3	5	8	12
Timber.....	7	10	15	20
Brickwork and Masonry	20	30	..	..

In cast iron the factors are high to allow for unknown internal stresses.

Prof. Wood in his "Resistance of Materials" says: "In regard to the margin that should be left for safety, much depends upon the character of the loading. If the load is simply a dead weight, the margin may be comparatively small; but if the structure is to be subjected to percussive forces or shocks, the margin should be comparatively large on account of the indeterminate effect produced by the force. In machines which are subjected to a constant jar while in use, it is very difficult to determine the proper margin which is consistent with economy and safety. Indeed, in such cases, economy as well as safety generally consists in making them *excessively* strong, as a single breakage may cost much more than the extra material necessary to fully insure safety."

For discussion of the resistance of materials to repeated stresses and shocks, see pages 275 to 285.

Instead of using factors of safety, it is becoming customary in designing to fix a certain number of pounds per square inch as the maximum stress which will be allowed on a piece. Thus, in designing a boiler, instead of naming a factor of safety of 6 for the plates and 10 for the stay-bolts, the ultimate tensile strength of the steel being from 50,000 to 60,000 lbs. per sq. in., an allowable working stress of 10,000 lbs. per sq. in. on the plates and 6000 lbs. per sq. in. on the stay-bolts may be specified instead. So also in the use of formulæ for columns (see page 285) the dimensions of a column are calculated after assuming a maximum allowable compressive stress per square inch on the concave side of the column.

The factors for masonry under dead load as given by Rankine and by Unwin, viz., 4 and 20, show a remarkable difference, which may possibly be explained as follows: If the actual crushing strength of a pier of masonry is known from direct experiment, then a factor of safety of 4 is sufficient for a pier of the same size and quality under a steady load; but if the crushing strength is merely assumed from figures given by the authorities (such as the crushing strength of pressed brick, quoted above from Howe's Retaining Walls, 40 to 300 tons per square foot, average 170 tons), then a factor of safety of 20 may be none too great. In this case the factor of safety is really a "factor of ignorance."

The selection of the proper factor of safety or the proper maximum unit stress for any given case is a matter to be largely determined by the judgment of the engineer and by experience. No definite rules can be given. The customary or advisable factors in many particular cases will be found where these cases are considered throughout this book. In general the following circumstances are to be taken into account in the selection of a factor:

1. When the ultimate strength of the material is known within narrow limits, as in the case of structural steel when tests of samples have been made, when the load is entirely a steady one of a known amount, and there is no reason to fear the deterioration of the metal by corrosion, the lowest factor that should be adopted is 3.

2. When the circumstances of 1 are modified by a portion of the load being variable, as in floors of warehouses, the factor should be not less than 4.

3. When the whole load, or nearly the whole, is apt to be alternately put on and taken off, as in suspension rods of floors of bridges, the factor should be 5 or 6.

4. When the stresses are reversed in direction from tension to compression, as in some bridge diagonals and parts of machines, the factor should be not less than 6.

5. When the piece is subjected to repeated shocks, the factor should be not less than 10.

6. When the piece is subject to deterioration from corrosion the section should be sufficiently increased to allow for a definite amount of corrosion before the piece be so far weakened by it as to require removal.

7. When the strength of the material, or the amount of the load, or both are uncertain, the factor should be increased by an allowance sufficient to cover the amount of the uncertainty.

8. When the strains are of a complex character and of uncertain amount, such as those in the crank-shaft of a reversing engine, a very high factor is necessary, possibly even as high as 40, the figure given by Rankine for shafts in millwork.

**Formulas for Factor of Safety.** — (F. E. Cardullo, *Mach'y*, Jan., 1906.) The apparent factor of safety is the product of four factors, or,

$$F = a \times b \times c \times d.$$

$a$  is the ratio of the ultimate strength of the material to its elastic limit, not the yield point, but the true elastic limit within which the material is, in so far as we can discover, perfectly elastic, and takes no permanent set. Two reasons for keeping the working stress within this limit are: (1) that the material will rupture if strained repeatedly beyond this limit; and (2) that the form and dimensions of the piece would be destroyed under the same circumstances.

The second factor,  $b$ , is one depending upon the character of the stress produced within the material. The experiments of Wohler proved that the repeated application of a stress less than the ultimate strength of a material would rupture it. Prof. J. B. Johnson's formula for the relation between the ultimate strength and the "carrying strength" under conditions of variable loads is as follows:

$$f = U \div (2 - p_1/p),$$

where  $f$  is the "carrying strength" when the load varies repeatedly between a maximum value,  $p$ , and a minimum value,  $p_1$ , and  $U$  is the ultimate strength of the material. The quantities  $p$  and  $p_1$  have plus signs when they represent loads producing tension, and minus signs when they represent loads producing compression.

If the load is variable the factor  $b$  must then have a value,

$$b = U/f = 2 - p_1/p.$$

Taking a load varying between zero and a maximum,

$$p_1/p = 0, \text{ and } b = 2 - p_1/p = 2.$$

Taking a load that produces alternately a tension and a compression equal in amount,

$$p' = -p \text{ and } p_1/p = -1, \text{ and } b = 2 - p_1/p = 2 - (-1) = 3.$$

The third factor,  $c$ , depends upon the manner in which the load is applied to the piece. When the load is suddenly applied  $c = 2$ . When not all of the load is applied suddenly, the factor 2 is reduced accordingly. If a certain fraction of the load,  $n/m$ , is suddenly applied, the factor is  $1 + n/m$ .

The last factor,  $d$ , we may call the "factor of ignorance." All the other factors have provided against known contingencies; this provides against the unknown. It commonly varies in value between  $1\frac{1}{2}$  and 3, although occasionally it becomes as great as 10. It provides against excessive or accidental overload, unexpectedly severe service, unreliable or imperfect materials, and all unforeseen contingencies of manufacture or operation. When we know that the load will not be likely to be increased, that the material is reliable, that failure will not result disastrously, or even that the piece for some reason must be small or light, this factor will be reduced to its lowest limit,  $1\frac{1}{2}$ . When life or property would be endangered by the failure of the piece, this factor must be made

larger. Thus, while it is  $1\frac{1}{2}$  to 2 in most ordinary steel constructions, it is rarely less than  $2\frac{1}{2}$  for steel in a boiler.

The reliability of the material in a great measure determines the value of this factor. For instance, in all cases where it would be  $1\frac{1}{2}$  for mild steel, it is made 2 for cast iron. It will be larger for those materials subject to internal strains, for instance for complicated castings, heavy forgings, hardened steel, and the like, also for materials subject to hidden defects, such as internal flaws in forgings, spongy places in castings, etc. It will be smaller for ductile and larger for brittle materials. It will be smaller as we are sure that the piece has received uniform treatment, and as the tests we have give more uniform results and more accurate indications of the real strength and quality of the piece itself. In fixing the factor *d*, the designer must depend on his judgment, guided by the general rules laid down.

**Table of Factors of Safety.**

The following table may assist in a proper choice of the factor of safety. It shows the value of the four factors for various materials and conditions of service.

CLASS OF SERVICE OR MATERIALS.	Factor				F
	a	b	c	d	
Boilers.. .. .	2	1	1	$2\frac{1}{4}$ -3	$4\frac{1}{2}$ -6
Piston and connecting rods for double-acting engines.. .. .	$1\frac{1}{2}$ -2	3	2	$1\frac{1}{2}$	$13\frac{1}{2}$ -18
Piston and connecting rod for single-acting engines.. .. .	$1\frac{1}{2}$ -2	2	2	$1\frac{1}{2}$	9 -12
Shaft carrying bandwheel, fly-wheel, or armature.. .. .	$1\frac{1}{2}$ -2	3	1	$1\frac{1}{2}$	$6\frac{3}{4}$ - 9
Lathe spindles.. .. .	2	2	2	$1\frac{1}{2}$	12
Mill shafting. . . . .	2	3	2	2	24
Steel work in buildings.. .. .	2	1	1	2	4
Steel work in bridges.. .. .	2	1	1	$2\frac{1}{2}$	5
Steel work for small work.. .. .	2	1	2	$1\frac{1}{2}$	6
Cast iron wheel rims.. .. .	2	1	1	10	20
Steel wheel rims.. .. .	2	1	1	4	8
<b>MATERIALS.</b>		<b>Minimum Values.</b>			
Cast iron and other castings.. .. .	2	1	1	2	4
Wrought iron or mild steel.. .. .	2	1	1	$1\frac{1}{2}$	3
Oil tempered or nickel steel.. .. .	$1\frac{1}{2}$	1	1	$1\frac{1}{2}$	$2\frac{1}{4}$
Hardened steel.. .. .	$1\frac{1}{2}$	1	1	2	3
Bronze and brass, rolled or forged.. .. .	2	1	1	$1\frac{1}{2}$	3

**THE MECHANICAL PROPERTIES OF CORK.**

Cork possesses qualities which distinguish it from all other solid or liquid bodies, namely, its power of altering its volume in a very marked degree in consequence of change of pressure. It consists, practically, of an aggregation of minute air-vessels, having thin, water-tight, and very strong walls, and hence, if compressed, the resistance to compression rises in a manner more like the resistance of gases than the resistance of an elastic solid such as a spring. In a spring the pressure increases in proportion to the distance to which the spring is compressed, but with gases the pressure increases in a much more rapid manner; that is, inversely as the volume which the gas is made to occupy. But from the permeability of cork to air, it is evident that, if subjected to pressure in one direction only, it will gradually part with its occluded air by effusion, that is, by its passage through the porous walls of the cells in which it is contained. The gaseous part of cork constitutes 53% of its bulk. Its elasticity has not only a very considerable range, but it is very persistent. Thus in the better kind of corks used in bottling the corks expand the instant they escape from the bottles. This expansion may amount to an increase of volume of 75%, even after the corks have been kept in a state of compression in the bottles for ten years. If the cork be steeped in hot water, the volume continues to increase till it attains nearly three times that which it occupied in the neck of the bottle.

When cork is subjected to pressure a certain amount of permanent



deformation or "permanent set" takes place very quickly. This property is common to all solid elastic substances when strained beyond their elastic limits, but with cork the limits are comparatively low. Besides the permanent set, there is a certain amount of sluggish elasticity — that is, cork on being released from pressure springs back a certain amount at once, but the complete recovery takes an appreciable time.

Cork which had been compressed and released in water many thousand times had not changed its molecular structure in the least, and had continued perfectly serviceable. Cork which has been kept under a pressure of three atmospheres for many weeks appears to have shrunk to from 80% to 85% of its original volume. — *Van Nostrand's Eng'g Mag.*, 1886, xxxv. 307.

### VULCANIZED INDIA-RUBBER.

The specific gravity of a rubber compound, or the number of cubic inches to the pound, is generally taken by buyers as a correct index of the value, though in reality such is often very far from being the case. In the rubber works the qualities of the rubber made vary from floating, the best quality, to densities corresponding to 11 or 12 cu. in. to the pound, the latter densities being in demand by consumers with whom price appears to be the main consideration. Such densities as these can only be obtained by utilizing to the utmost the quality that rubber exhibits of taking up a large bulk of added matters. — *Eng'g*, 1897.

Lieutenant L. Vladomiroff, a Russian naval officer, has recently carried out a series of tests at the St. Petersburg Technical Institute with view to establishing rules for estimating the quality of vulcanized india-rubber. The following, in brief, are the conclusions arrived at, recourse being had to physical properties, since chemical analysis did not give any reliable result: 1. India-rubber should not give the least sign of superficial cracking when bent to an angle of 180 degrees after five hours of exposure in a closed air-bath to a temperature of 125° C. The test-pieces should be 2.4 inches thick. 2. Rubber that does not contain more than half its weight of metallic oxides should stretch to five times its length without breaking. 3. Rubber free from all foreign matter, except the sulphur used in vulcanizing it, should stretch to at least seven times its length without rupture. 4. The extension measured immediately after rupture should not exceed 12% of the original length, with given dimensions. 5. Suppleness may be determined by measuring the percentage of ash formed in incineration. This may form the basis for deciding between different grades of rubber for certain purposes. 6. Vulcanized rubber should not harden under cold. These rules have been adopted for the Russian navy. — *Iron Age*, June 15, 1893.

**Singular Action of India Rubber under Tension.** — R. H. Thurston, *Am. Mach.*, Mar. 17, 1898, gives a diagram showing the stretch at different loads of a piece of partially vulcanized rubber. The results translated into figures are:

Load, lbs.....	30	50	80	120	150	200	320	430
Stretch per in. of length, in.....	0.5	1.	2.2	4	5	6	7	7.5
Stretch per 10 lbs. increase of load....	0.17	0.25	0.4	0.45	0.33	0.20	0.08	0.04

Up to about 30% of the breaking load the rubber behaves like a soft metal in showing an increasing rate of stretch with increase of load, then the rate of stretch becomes constant for a while and later decreases steadily until before rupture it is less than one-tenth of the maximum. Even when stretched almost to rupture it restores itself very nearly to its original dimensions on removing the load, and gradually recovers a part of the loss of form at that instant observable. So far as known, no other substance shows this curious relation of stretch to load.

**Rubber Goods Analysis.** Randolph Bolling. (*Iron Age*, Jan. 28, 1909.) The loading of rubber goods used in manufacturing establishments with zinc oxide, lead sulphate, calcium sulphate, etc., and the employment of the so-called "rubber substitutes" mixed with good rubber call for close inspection of the works chemist in order to determine the value of the samples and materials received. The following method of analysis is recommended:

Thin strips of the rubber must be cut into small bits about the size of



No. 7 shot. A half gram is heated in a 200 c.c. flask with red fuming nitric acid on the hot plate until all organic matter has been decomposed, and the total sulphur is determined by precipitation as barium sulphate. The difference between the total and combined sulphur gives the per cent that has been used for vulcanization. Free sulphur indicates either that improper methods were used in vulcanizing or that an excessive per cent of substitutes was employed. Following is a scheme for the analysis of india-rubber articles:

1. Extraction with acetone: A. Solution: Resinous constituents of india-rubber, fatty oils, mineral oils, resin oils, solid hydrocarbons, resins, free sulphur. B. Residue.

2. Extraction with pyridine: C. Extract: Tar, pitch, bituminous bodies, sulphur in above. D. Residue.

3. Extraction with alcoholic potash: E. Extract: Chlorosulphide substitutes, sulphide substitutes, oxidized (blown) oils, sulphur in substitutes, chlorine in substitutes. F. Residue.

4. Extraction with nitro-naphthalene: G. Extract: India-rubber, sulphur in india-rubber, chlorine in india-rubber, the total of the above three estimated by loss. H. Residue.

5. Extraction with boiling water: I. Extract: Starch (farina), dextrine. K. Residue: Mineral matter, free carbon, fibrous materials, sulphur in inorganic compounds.

6. Separate estimations: Total sulphur, chlorine in rubber.

### SPECIFICATIONS FOR AIR HOSE.

The Bureau of Construction and Repair of the U. S. Navy, in 1910, adopted the following specifications for air hose:

1. The hose to be made up of an inner rubber tube, three or more canvas or braided layers, and an outer rubber cover; to be of the internal diameter required. 2. The tube and cover shall be free from pitting or other irregularities; the tube shall not be less than  $1/16$  in., and the cover not less than  $1/32$  in. in thickness. The hose to be of the best quality rubber, duck and friction, and to be capable of standing a hydrostatic pressure of 600 lb. 3. Samples will be submitted to the mechanical kinking test. The samples should stand the test for the following length of time without leakage at 90 lb. air pressure

$3/8$ in. ....	45 hours.
$7/16$ in. ....	40 hours.
$5/8$ in. ....	30 hours.
$3/4$ in. ....	25 hours.
$11/4$ in. ....	3 hours.

The kinking test is conducted as follows: The test piece, 20 in. in length, is fastened to couplings made up on  $45^\circ$  elbows, the stationary end turned up and the moving end turned down. The ends of the couplings when level are 7 in. apart. The moving end travels vertically through a distance of 14 in., and the speed is such that the hose is kinked about 80 times a minute, the kinking occurring in two places about 4 in. from each end. During this test an air pressure of about 90 lb. per sq. in. is maintained in the hose. The kinking is done on a special machine designed to kink the hose at the speed specified.

### NICKEL.

**Properties of Nickel.**—(F. L. Sperry, *Tran. A.I.M.E.*, 1895). Nickel has similar physical properties to those of iron and copper. It is less malleable and ductile than iron, and less malleable and more ductile than copper. It alloys with these metals in all proportions. It has nearly the same specific gravity as copper, and is slightly heavier than iron. It melts at a temperature of about  $2900^\circ$  to  $3200^\circ$  F. A small percentage of carbon in metallic nickel lowers its melting-point perceptibly. Nickel is harder than either iron or copper; is magnetic, but will not take a temper. It has a grayish-white color, takes a fine polish, and may be rolled easily into thin plates or drawn into wire. It is unappreciably affected by atmospheric action, or by salt water. Commercial nickel is from 98 to 99 per cent pure. The impurities are iron, copper, silicon, sulphur, arsenic, carbon, and (in some nickel) a kernel of unreduced oxide. It is not difficult to cast, and acts like some irons

in being cold-short. Cast bars are likely to be porous or spongy, but, after hammering or rolling, are compact and tough.

The average results of several tests are as follows: Castings, tensile strength, 85,000 lbs. per sq. in., elongation, 12%; wrought nickel, T. S., 96,000, El., 14%; wrought nickel, annealed, T. S., 95,000, El., 23%; hard rolled, T. S., 78,000, El., 10%. (See also page 473.)

Nickel readily takes up carbon, and the porous nature of the metal is undoubtedly due to occluded gases. According to Dr. Wedding, nickel may take up as much as 9% of carbon, which may exist either as amorphous or as graphitic carbon.

Dr. Fleitmann, of Germany, discovered that a small quantity of pure magnesium would free nickel from occluded gases and give a metal capable of being drawn or rolled perfectly free from blow-holes, to such an extent that the metal may be rolled into thin sheets 3 feet in width. Aluminum or manganese may be used equally as well as a purifying agent; but either, if used in excess, serves to make the nickel very much harder. Nickel will alloy with most of the useful metals, and generally adds the qualities of hardness, toughness, and ductility.

### ALUMINUM—ITS PROPERTIES AND USES.

(Compiled from notes by Alfred E. Hunt, and from publications of the Aluminum Co. of America, 1914.)

The specific gravity of aluminum varies according to its treatment, as follows: Pure cast, 2.56; sheets, wire, etc., rolled and unannealed, 2.68; ditto, annealed, 2.66. The casting alloys range in specific gravity from 2.82 to 2.91. Based on these values, an ingot of cast aluminum 12 in. square, 1 in. thick, weighs 13.3024 lb.; a rolled sheet 12 in. square, 1 in. thick, weighs 13.9259 lb.; a 1-in. cast round bar, 12 in. long, weighs 0.8706 lb.; a 1-in. rolled bar, 12 in. long, weighs 0.9114 lb.; a cubic foot of cast aluminum, 159.6288 lb.; and a cubic foot of rolled aluminum, 167.1114 lb. Taking the weight of rolled aluminum as 1, the weight of rolled wrought iron is 2.8742; of rolled steel, 2.9322; of rolled copper, 3.3321; of rolled brass, 3.19. Wood for structures can be taken as about one-third the weight of aluminum.

Chemically, aluminum is readily soluble in hydrochloric acid, and in strong solutions of caustic alkalis. Hot dilute sulphuric acid slowly dissolves it, but concentrated sulphuric acid acts very slowly. Nitric acid, cold, either dilute or concentrated, has but little effect; hot, it acts very slowly. Sulphur has no action at less than a red heat. Chlorine, fluorine, bromine, iodine, and fluohydric acid rapidly corrode it. Salt water has little effect on it, and it resists sea water better than does iron, steel, or copper. Aluminum strips on the sides of a wooden vessel in sea water corroded less than 0.005 inch in six months, about half the corrosion of copper strips. Ammonium solutions gradually attack the surface of aluminum, forming a coating which is more resistant than the metal, and which while rapidly attacked by concentrated acid or alkali solutions, resists dilute mineral and organic acids, and dry or moist air. It is not attacked by CO<sub>2</sub>, CO, or H<sub>2</sub>S, but will absorb these gases when heated.

The presence of a considerable quantity of aluminum decreases its resistance to corrosion. Commercial aluminum, such as is used for rolling or casting alloys, contains, however, only a negligible quantity of impurities. Occluded gases in molten aluminum cause blow-holes in the ingots, which form laminated plates when the metal is rolled or hammered, which are more liable to corrode than sound metal. Silicon and iron are the impurities usually found, the former ranging in commercial aluminum from 0.30 to 2.0 per cent, and the latter from 0.15 to 2.0 per cent. Other metals are frequently alloyed with aluminum to increase the hardness, rigidity, and strength. See *Alloys of Aluminum*, page 396.

Aluminum is electro positive as regards the common metals, and forms a galvanic couple when in contact with them. In service it should be insulated from them by rubber gaskets, or washers, or by a liberal coat of heavy paint.

In malleability pure aluminum is exceeded only by gold and silver. It is exceeded in ductility only by gold, silver, platinum, iron, and

copper. Sheets of aluminum have been rolled down to 0.0005 in. thick and beaten into leaf nearly as thin as gold leaf. The metal is most malleable at a temperature of between 400° and 600° F., and at this temperature it can be drawn down between rolls with nearly as much draught upon it as with heated steel. It has also been drawn into the finest wire. By the Mannesmann process aluminum tubes have been made in Germany.

The electrical conductivity of aluminum is 61.67, silver being taken as 100. On the same scale, the conductivity of copper is 97.62; of gold, 76.61; of zinc, 29.57; of iron, 14.57; of platinum, 14.42. Aluminum wire, weight for weight, has a conductivity of 206, taking copper as 100 and aluminum as 62, the aluminum wire having an area 3.33 that of the copper wire. Pure aluminum is practically non-magnetic.

Aluminum melts at 1215° F. It does not volatilize at any temperature produced by the combustion of carbon, but it is inadvisable to heat it much beyond the melting point or to allow it to remain molten for a great length of time, on account of its capacity to absorb gases. It may be cast in dry or green sand molds or in metal chills, and should be melted in plumbago crucible. Cores should be as soft as will permit safe manipulation. A good core mixture is 15 parts core sand, 1 part rosin. The core should be sprayed with molasses water, baked and washed in plumbago water.

The mean specific heat of aluminum is 0.2185 (water = 1), being higher than any other metal except magnesium and the alkali metals. Its latent heat of fusion is 51.4 B.T.U. per lb. The coefficient of linear expansion of aluminum is 0.0000130 per degree F. The thermal conductivity, according to Roberts-Austen, is 31.33 (silver = 100), copper being the only baser metal which exceeds it. Wiederman and Franz give the thermal conductivity for the metal unannealed as 38.87, and annealed as 37.96. Its shrinkage in cooling is 0.2031 in. per foot, slightly more than ordinary brass. The shrinkage varies somewhat with the thickness—thicker castings shrinking more than thinner ones. The hardness of aluminum varies with the purity, the purest metal being the softest. In the Bottone scale the hardness of the diamond is 3010, while that of aluminum is 821.

Aluminum under tension, and section for section, is about as strong as cast iron. Its tensile strength is increased by cold rolling or cold forging, and there are alloys which add considerably to the tensile strength without increasing the specific gravity to over 3 or 3.25.

The strength of commercial aluminum is given in the following table as the result of many tests:

Form.	Elastic Limit per sq. in. in Tension, lbs.	Ultimate Strength per sq. in. in Tension, lbs.	Percentage of Reduction of Area in Tension.
Castings.....	8,500	12,000-14,000	15
Sheet.....	12,500-25,000	24,000-40,000	20-30
Wire.....	16,000-33,000	25,000-65,000	40-60
Bars.....	14,000-33,000	28,000-40,000	30-40

The elastic limit per square inch under compression in cast cylindrical columns of length twice the diameter is 3500 lb. The ultimate strength per square inch under compression in cylinders of the same form is 12,000. The modulus of elasticity of cast aluminum is about 9,000,000. It is rather an open metal in its texture, and for cylinders to stand pressure an increase in thickness must be given to allow for this porosity. Its maximum shearing stress in castings is about 12,000, and in forgings about 16,000, or about that of pure copper. Its texture and strength are improved by forging or pressing at a temperature of about 600° F.

Pure aluminum is too soft and lacking in tensile strength and rigidity for many purposes. Valuable alloys are now being made which seem to give great promise for the future. They are alloys containing from 2% to 7% or 8% of copper, manganese, iron, and nickel. See alloys of aluminum, page 396.

Aluminum can be worked by any of the common mechanical processes, as rolling, stamping, drawing, tapping, spinning, forging, ex-



truding or machining. Owing to the ductility of the metal, sheet aluminum can be given a deeper stamp or heavier draw than most metals. A draw of over one-quarter to one-third more in depth than can be taken with copper, brass or steel can be made on aluminum sheet of 20 B. & S. gauge or heavier. The same sort of tools and processes are used for stamping as are used for other metal. The tools should be lubricated with vaseline or any greasy oil which is free from grit. It is practically unnecessary to anneal the work between re-draws.

In spinning it is also unnecessary to anneal the shells after they come from the press, when the first operation is done in the drawing press. The speed of the lathe should range from 2,000 to 3,000 r. p. m., and the best results in spinning will be obtained by the use of hard wood spinning stocks and metal chucks. For finishing and burnishing, steel tools should be used. The best lubricant is soap, tallow, or paraffin candles. In drop forging aluminum, the castings to be forged should be made a little smaller in their horizontal diameter and a little greater in the vertical diameter than is desired for the finished forging. They should be heated to the annealing temperature, about 700° F., before being placed in the die.

Aluminum can be extruded into shapes which can be obtained in no other way. In these shapes, the metal has a continuity of structure which renders it easier in machining than fabricated shapes made by other methods. It is difficult at the present time (1914), to extrude a shape of greater diameter than 6 inches or one having a thickness of wall of less than  $\frac{1}{8}$  inch.

In machining, the tools should have a highly whetted edge, such as would be used in wood working, and they should also have a large clearance. That is, the thickness of the blades should increase very slowly from its edge. The tools should operate somewhat faster than for brass, and the feed should be slightly slower in proportion. A good lubricant should be freely used: No. 1 grade lard oil, or lard oil or carbon oil mixed with 25 per cent of some animal oil, give satisfactory results. Another satisfactory lubricant is a mixture of lard oil 25 per cent by volume with benzine 75 per cent.

In sawing, an ordinary circular saw on a table may be used. The teeth should have no "set," the saw should be thinner at the center than at the periphery, and should run at a peripheral speed of 3,500 to 4,000 feet per minute.

For drilling, an ordinary twist drill may be used, but it should be exceedingly sharp. The drill should rotate about 50 per cent faster, with a feed about 25 per cent slower, than would be used for brass. In tapping, a sharp tap only should be used and a hole drilled with a drill from one to three sizes larger than for brass. The best tap is one having a single spiral flute with a lead of about one turn in every three inches. The best tapping lubricant is the lard oil—benzine mixture noted above.

Aluminum may be finished by caustic dipping and scratch brushing. In caustic dipping, the article is first dipped into the benzine and then into a strong solution of caustic alkali, which is kept at the boiling point, after which it should be placed in a strong hot solution of nitric acid. After draining the acid, the aluminum should be dipped in boiling hot water, which should be constantly drained off and renewed by an addition of fresh water. On removal from the water, it should be rapidly dried over a steam coil. In scratch brushing, the metal is carefully cleaned and then applied to the scratch brush wheel, which rotates at from 1500 to 2000 r. p. m.

**Soldering and Welding Aluminum.**—Aluminum can be readily electrically welded, but soldering is not altogether satisfactory. The high heat conductivity of the aluminum withdraws the heat of the molten solder so rapidly that it "freezes" before it can flow sufficiently. A German solder said to give good results is made of 80% tin to 20% zinc, using a flux composed of 80 parts stearic acid, 10 parts chloride of zinc, and 10 parts of chloride of tin. Pure tin, fusing at 250° C., has also been used as a solder. The use of chloride of silver as a flux has been patented, and used with ordinary soft solder has given some success. A pure nickel soldering-bit should be used, as it does not discolor aluminum as copper bits do.



The following table of aluminum solders which have been successfully used appeared in *Machinery*, Dec., 1914. See also page 410.

Tin.	Alum- inum.	Zinc.	Cop- per.	Bis- muth.	Lead.	Phos- phor- Tin*	Silver	Anti- mony	Cad- mium.	Mag- nes- ium.
95.00	.....	.....	.....	5.00	.....	.....	.....	.....	.....	.....
78.50	2.00	19.00	.....	.....	.....	0.50	.....	.....	.....	.....
	66.70	.....	.....	.....	.....	.....	33.30	.....	.....	.....
20.00	70.00	.....	.....	.....	.....	.....	10.00	.....	.....	.....
97.00	.....	.....	.....	3.00	.....	.....	.....	.....	.....	.....
	6.00	89.50	4.50	.....	.....	.....	.....	.....	.....	.....
71.25	2.25	26.00	.....	.....	.....	0.50	.....	.....	.....	.....
60.00	4.00	8.00	4.00	.....	12.00	.....	12.00	.....	.....	.....
37.50	.....	25.00	37.50	.....	.....	.....	.....	.....	.....	.....
	8.00	92.00	.....	.....	.....	.....	.....	.....	.....	.....
30.00	.....	20.00	.....	.....	.....	.....	.....	.....	50.00	.....
80.00	2.25	17.00	.....	.....	.....	0.75	.....	.....	.....	.....
66.00	15.50	.....	.....	9.00	.....	.....	.....	7.00	..†..	2.25
15.50	2.50	78.25	.....	.....	2.50	1.25	.....	.....	.....	.....
	20.00	65.00	15.00	.....	.....	.....	.....	.....	.....	.....
49.05	.....	20.31	1.15	.....	26.06	.....	.....	3.43	.....	.....
30.00	70.00	.....	.....	.....	.....	.....	.....	.....	.....	.....
	4.00	94.00	2.00	.....	.....	.....	.....	.....	.....	.....
85.10	10.80	.....	.....	.....	.....	.....	.....	.....	1.35	2.75
60.00	.....	15.00	.....	5.00	10.00	.....	.....	5.00	.....	..‡..
86.00	.....	.....	.....	14.00	.....	.....	.....	.....	.....	.....
98.00	1.00	.....	.....	1.00	.....	.....	.....	.....	.....	.....
20.00	70.00	.....	10.00	.....	.....	.....	.....	.....	.....	.....
48.00	2.00	27.00	.....	.....	23.00	.....	.....	.....	.....	.....
90.00	5.00	.....	.....	5.00	.....	.....	.....	.....	.....	.....
84.95	.....	.....	.....	15.05	.....	.....	.....	.....	.....	.....

\* 10% phosphorus.

† This solder also contains 0.25% vanadium.

‡ This solder also contains 5% chromium.

**Aluminum Wire.**—Tension tests. Diam. 0.128 in. 14 tests. E.L. 12,500 to 19,100; T. S. 25,800 to 26,900 lbs. per sq. in.; el. 0.30 to 1.02% in 48 ins.; Red. of area, 75.0 to 83.4%. Mod. of el. 8,800,000 to 10,700,000.—*Tech. Quar.*, xii, 1899.

**Aluminum Rod.**—Torsion tests. 10 samples, 0.257 in. diam. Apparent outside fiber stress, lbs. per sq. in. 15,900 to 18,300 lbs. per sq. in. 11 samples, 0.367 in. diam. Apparent outside fiber stress, 18,400 to 19,200. 10 samples, 0.459 in. diam. Apparent outside fiber stress, 20,700 to 21,500 lbs. per sq. in. The average number of turns per inch for the three series were respectively, 1.58 to 3.65; 1.20 to 2.64; 0.87 to 1.06.—*Ibid.*

## ALLOYS.

## ALLOYS OF COPPER AND TIN.

(Extract from Report of U. S. Test Board. \*)

Number.	Mean Com- position by Analysis.		Tensile Strength, lbs. per sq. in.	Elastic Limit, lbs. per sq. in.	Elongation, per cent in 5 inches.	Transverse Test, Modulus of Rupture.	Deflection, 1" sq Bar 22 in. long, inches.	Crushing Strength, lbs. per sq. in.	Torsion Tests.	
	Cop- per.	Tin.							Maximum Tor. Mo- ment.ft.-lbs	Angle of Torsion, degrees.
1	100.	...	27,800	14,000	6.47	29,848	bent.	42,000	143	153
1a	100.	...	12,760	11,000	0.47	21,251	2.31	39,000	65	40
2	97.89	1.90	24,580	10,000	13.33	...	...	34,000	150	317
3	96.06	3.76	32,000	16,000	14.29	33,232	bent.	42,048	157	247
4	94.11	5.43	...	...	...	38,659	...	...	...	...
5	92.11	7.80	28,540	19,000	5.53	43,731	"	42,000	160	126
6	90.27	9.58	26,860	15,750	3.66	49,400	"	38,000	175	114
7	88.41	11.59	...	...	...	60,403	"	...	...	...
8	87.15	12.73	29,430	20,000	3.33	34,531	4.00	53,000	182	100
9	82.70	17.34	...	...	...	67,930	0.63	...	...	...
10	80.95	18.84	32,980	...	0.04	56,715	0.49	78,000	190	16
11	77.56	22.25	...	...	0.	29,926	0.16	...	...	...
12	76.63	23.24	22,010	22,010	0.	32,210	0.19	114,000	122	3.4
13	72.89	26.85	...	...	0.	9,512	0.05	...	...	...
14	69.84	29.88	5,585	5,585	0.	12,076	0.06	147,000	18	1.5
15	68.58	31.26	...	...	0.	9,152	0.04	...	...	...
16	67.87	32.10	...	...	0.	9,477	0.05	...	...	...
17	65.34	34.47	2,201	2,201	0.	4,776	0.02	84,700	16	1
18	56.70	43.17	1,455	1,455	0.	2,126	0.02	...	...	...
19	44.52	55.28	3,010	3,010	0.	4,776	0.03	35,800	23	1
20	34.22	65.80	3,371	3,371	0.	5,384	0.04	19,600	17	2
21	23.35	76.29	6,775	6,775	0.	12,408	0.27	...	...	...
22	15.08	84.62	...	...	...	9,063	0.86	6,500	23	25
23	11.49	88.47	6,380	3,500	4.10	10,706	5.85	10,100	23	62
24	8.57	91.39	6,450	3,500	6.87	5,305	bent.	9,800	23	132
25	3.72	96.31	4,780	2,750	12.32	6,925	"	9,800	23	220
26	0.	100.	3,505	...	35.51	3,740	"	6,400	12	557

\* The tests of the alloys of copper and tin and of copper and zinc, the results of which are published in the Report of the U. S. Board appointed to test Iron, Steel, and other Metals, Vols. I and II, 1879 and 1881, were made by the author under direction of Prof. R. H. Thurston, chairman of the Committee on Alloys. See preface to the report of the Committee, in Vol. I.

Nos. 1a and 2 were full of blow-holes.

Tests Nos. 1 and 1a show the variation in cast copper due to varying conditions of casting. In the crushing tests Nos. 12 to 20, inclusive, crushed and broke under the strain, but all the others bulged and flattened out. In these cases the crushing strength is taken to be that which caused a decrease of 10% in the length. The test-pieces were 2 in. long and 5/8 in. diameter. The torsional tests were made in Thurston's torsion-machine, on pieces 5/8 in. diameter and 1 in. long between heads.

**Specific Gravity of the Copper-tin Alloys.** — The specific gravity of copper, as found in these tests, is 8.874 (tested in turnings from the ingot, and reduced to 39.1° F.). The alloy of maximum sp. gr. 8.956 contained 62.42 copper, 37.48 tin, and all the alloys containing less than

37% tin varied irregularly in sp. gr. between 8.65 and 8.93, the density depending not on the composition, but on the porosity of the casting. It is probable that the actual sp. gr. of all these alloys containing less than 37% tin is about 8.95, and any smaller figure indicates porosity in the specimen.

From 37% to 100% tin, the sp. gr. decreases regularly from the maximum of 8.956 to that of pure tin, 7.293.

### Note on the Strength of the Copper-tin Alloys.

The bars containing from 2% to 24% tin, inclusive, have considerable strength, and all the rest are practically worthless for purposes in which strength is required. The dividing line between the strong and brittle alloys is precisely that at which the color changes from golden yellow to silver-white, viz., at a composition containing between 24% and 30% of tin.

It appears that the tensile and compressive strengths of these alloys are in no way related to each other, that the torsional strength is closely proportional to the tensile strength, and that the transverse strength may depend in some degree upon the compressive strength, but it is much more nearly related to the tensile strength. The modulus of rupture, as obtained by the transverse tests, is, in general, a figure between those of tensile and compressive strengths per square inch, but there are a few exceptions in which it is larger than either.

The strengths of the alloys at the copper end of the series increase rapidly with the addition of tin till about 4% of tin is reached. The transverse strength continues regularly to increase to the maximum, till the alloy containing about 17½% of tin is reached, while the tensile and torsional strengths also increase, but irregularly, to the same point. This irregularity is probably due to porosity of the metal, and might possibly be removed by any means which would make the castings more compact. The maximum is reached at the alloy containing 82.70 copper, 17.34 tin, the transverse strength, however, being very much greater at this point than the tensile or torsional strength. From the point of maximum strength the figures drop rapidly to the alloys containing about 27.5% of tin, and then more slowly to 37.5%, at which point the minimum (or nearly the minimum) strength, by all three methods of test, is reached. The alloys of minimum strength are found from 37.5% tin to 52.5% tin. The absolute minimum is probably about 45% of tin.

From 52.5% of tin to about 77.5% tin there is a rather slow and irregular increase in strength. From 77.5% tin to the end of the series, or all tin, the strengths slowly and somewhat irregularly decrease.

The results of these tests do not seem to corroborate the theory given by some writers, that peculiar properties are possessed by the alloys which are compounded of simple multiples of their atomic weights or chemical equivalents, and that these properties are lost as the compositions vary more or less from this definite constitution. It does appear that a certain percentage composition gives a maximum strength and another certain percentage a minimum, but neither of these compositions is represented by simple multiples of the atomic weights.

There appears to be a regular law of decrease from the maximum to the minimum strength which does not seem to have any relation to the atomic proportions, but only to the percentage compositions.

**Hardness.**—The pieces containing less than 24 % of tin were turned in the lathe without difficulty, a gradually increasing hardness being noticed, the last named giving a very short chip, and requiring frequent sharpening of the tool.

With the most brittle alloys it was found impossible to turn the test-pieces in the lathe to a smooth surface. No. 13 to No. 17 (26.85 to 34.47 tin) could not be cut with a tool at all. Chips would fly off in advance of the tool and beneath it, leaving a rough surface; or the tool would sometimes, apparently, crush off portions of the metal, grinding it to powder. Beyond 40% tin the hardness decreased so that the bars could be easily turned.

## ALLOYS OF COPPER AND ZINC. (U. S. Test Board.)

No.	Mean Com- position by Analysis.		Tensile Str'gth, lbs. per sq. in.	Elastic Limit % of Break- ing Load, lbs. per sq. in.	Elongation % in 5 inches.	Trans- verse Test Modu- lus of Rup- ture.	Deflection 1/2" sq. bar 22" long, in.	Crush- ing Str'gth per sq. in., lbs.	Torsional Tests.	
	Cop- per.	Zinc.							Max. Tors. Moment ft.-lbs.	Angle of Tors. deg.
1	97.83	1.88	27,240	..	..	..	..	..	130	357
2	82.93	16.98	32,600	26.1	26.7	23,197	Bent	..	155	329
3	81.91	17.99	32,670	30.6	31.4	21,193	"	..	166	345
4	77.39	22.45	35,630	20.0	35.5	25,374	"	..	169	311
5	76.65	23.08	30,520	24.6	35.8	22,325	"	42,000	165	267
6	73.20	26.47	31,580	23.7	38.5	25,894	"	..	168	293
7	71.20	28.54	30,510	29.5	29.2	24,468	"	..	164	269
8	69.74	30.06	28,120	28.7	20.7	26,930	"	..	143	202
9	66.27	33.50	37,800	25.1	37.7	28,459	"	..	176	257
10	63.44	36.36	48,300	32.8	31.7	43,216	"	..	202	230
11	60.94	38.65	41,065	40.1	20.7	38,968	"	75,000	194	202
12	58.49	41.10	50,450	54.4	10.1	63,304	"	..	227	93
13	55.15	44.44	44,280	44.0	15.3	42,463	"	78,000	209	109
14	54.86	44.78	46,400	53.9	8.0	47,955	"	..	223	72
15	49.66	50.14	30,990	54.5	5.0	33,467	1.26	117,400	172	38
16	48.99	50.82	26,050	100	0.8	40,189	0.61	..	176	16
17	47.56	52.28	24,150	100	0.8	48,471	1.17	121,000	155	13
18	43.36	56.22	9,170	100	..	17,691	0.10	..	88	2
19	41.30	58.12	3,727	100	..	7,761	0.04	..	18	2
20	32.94	66.23	1,774	100	..	8,296	0.04	..	29	1
21	29.20	70.17	6,414	100	..	16,579	0.04	..	40	2
22	20.81	77.63	9,000	100	0.2	22,972	0.13	52,152	65	1
23	12.12	86.67	12,413	100	0.4	35,026	0.31	..	82	3
24	4.35	94.59	18,065	100	0.5	26,162	0.46	..	81	22
25	Cast.	Zinc.	5,400	75	0.7	7,539	0.12	22,000	37	142

**Variation in Strength of Gun-bronze, and Means of Improving the Strength.** — The figures obtained for alloys of from 7.8% to 12.7% tin, viz., from 26,860 to 29,430 pounds, are much less than are usually given as the strength of gun-metal. Bronze guns are usually cast under the pressure of a head of metal, which tends to increase the strength and density. The strength of the upper part of a gun casting, or sinking head, is not greater than that of the small bars which have been tested in these experiments. The following is an extract from the report of Major Wade concerning the strength and density of gun-bronze (1850): — Extreme variation of six samples from different parts of the same gun (a 32-pounder howitzer): Specific gravity, 8.487 to 8.835; tenacity, 26,428 to 52,192. Extreme variation of all the samples tested: Specific gravity, 8.308 to 8.850; tenacity, 23,108 to 54,531. Extreme variation of all the samples from the gun heads: Specific gravity, 8.308 to 8.756; tenacity, 23,529 to 35,484.

Major Wade says: The general results on the quality of bronze as it is found in guns are mostly of a negative character. They expose defects in density and strength, develop the heterogeneous texture of the metal in different parts of the same gun, and show the irregularity and uncertainty of quality which attend the casting of all guns, although made from similar materials, treated in like manner.

Navy ordnance bronze containing 9 parts copper and 1 part tin, tested at Washington, D.C., in 1875-6, showed a variation in tensile strength from 29,800 to 51,400 lbs. per square inch, in elongation from 3% to 58%, and in specific gravity from 8.39 to 8.88.

That a great improvement may be made in the density and tenacity of gun-bronze by compression has been shown by the experiments of Mr. S. B. Dean in Boston, Mass., in 1869, and by those of General Uchatius in Austria in 1873. The former increased the density of the



metal next the bore of the gun from 8.321 to 8.875, and the tenacity from 27,238 to 41,471 pounds per square inch. The latter, by a similar process, obtained the following figures for tenacity:

	Pounds per sq. in.
Bronze with 10% tin.....	72,053
Bronze with 8% tin.....	73,958
Bronze with 6% tin.....	77,656

## ALLOYS OF COPPER, TIN, AND ZINC.

(Report of U. S. Test Board, Vol. II, 1881.)

No. in Report.	Analysis, Original Mixture.			Transverse Strength.		Tensile Strength per square inch.		Elongation per cent in 5 inches.	
	Cu.	Sn.	Zn.	Modulus of Rupture.	Deflection, ins.	A.	B.	A.	B.
72	90	5	5	41,334	2.63	23,660	30,740	2.34	9.68
5	88.14	1.86	10	31,986	3.67	32,000	33,000	17.6	19.5
70	85	5	10	44,457	2.85	28,840	28,560	6.80	5.28
71	85	10	5	62,470	2.56	35,680	36,000	2.51	2.25
89	85	12.5	2.5	62,405	2.83	34,500	32,800	1.29	2.79
88	82.5	12.5	5	69,960	1.61	36,000	34,000	0.86	0.92
77	82.5	15	2.5	69,045	1.09	33,600	33,800	...	0.68
67	80	5	15	42,618	3.88	37,560	32,300	11.6	3.59
68	80	10	10	67,117	2.45	32,830	31,950	1.57	1.67
69	80	15	5	54,476	0.44	32,350	30,760	0.55	0.44
86	77.5	10	12.5	63,849	1.19	35,500	36,000	1.00	1.00
87	77.5	12.5	10	61,705	0.71	36,000	32,500	0.72	0.59
63	75	5	20	55,355	2.91	33,140	34,960	2.50	3.19
85	75	7.5	17.5	62,607	1.39	33,700	39,300	1.56	1.33
64	75	10	15	58,345	0.73	35,320	34,000	1.13	1.25
65	75	15	10	51,109	0.31	35,440	28,000	0.59	0.54
66	75	20	5	40,235	0.21	23,140	27,660	0.43	...
83	72.5	7.5	20	51,839	2.86	32,700	34,800	3.73	3.78
84	72.5	10	17.5	53,230	0.74	30,000	30,000	0.48	0.49
59	70	5	25	57,349	1.37	38,000	32,940	2.06	0.99
82	70	7.5	22.5	48,836	0.36	38,000	32,400	0.84	0.40
60	70	10	20	36,520	0.18	33,140	26,300	0.31	...
61	70	15	15	37,924	0.20	33,440	27,800	0.25	...
62	70	20	10	15,126	0.08	17,000	12,900	0.03	...
81	67.5	2.5	30	58,343	2.91	34,720	45,850	7.27	3.09
74	67.5	5	27.5	55,976	0.49	34,000	34,460	1.06	0.43
75	67.5	7.5	25	46,875	0.32	29,500	30,000	0.36	0.26
80	65	2.5	32.5	56,949	2.36	41,350	38,300	3.26	3.02
55	65	5	30	51,369	0.56	37,140	36,000	1.21	0.61
56	65	10	25	27,075	0.14	25,720	22,500	0.15	0.19
57	65	15	20	13,591	0.07	6,820	7,231	...	...
58	65	20	15	11,932	0.05	3,765	2,665	...	...
79	62.5	2.5	35	69,255	2.34	44,400	45,000	2.15	2.19
78	60	2.5	37.5	69,508	1.46	57,400	52,900	4.87	3.02
52	60	5	35	46,076	0.28	41,160	38,330	0.39	0.40
53	60	10	30	24,699	0.13	21,780	21,240	0.15	...
54	60	15	25	18,248	0.09	18,020	12,400	...	...
12	58.22	2.30	39.48	95,623	1.99	66,500	67,600	3.13	3.15
3	58.75	8.75	32.5	35,752	0.18	Broke	before test; very	...	brittle
4	57.5	21.25	21.25	2,752	0.02	725	1,300	...	...
73	55	0.5	44.5	72,308	3.05	68,900	68,900	9.43	2.88
50	55	5	40	38,174	0.22	27,400	30,500	0.46	0.43
51	55	10	35	28,258	0.14	25,460	18,500	0.29	0.10
49	50	5	45	20,814	0.11	23,000	31,300	0.66	0.45

The transverse tests were made in bars 1 in. square, 22 in. between supports. The tensile tests were made on bars 0.798 in. diam. turned from the two halves of the transverse-test bar, one half being marked *A* and the other *B*.

**Ancient Bronzes.** — The usual composition of ancient bronze was the same as that of modern gun-metal — 90 copper, 10 tin; but the proportion of tin varies from 5% to 15%, and in some cases lead has been found. Some ancient Egyptian tools contained 88 copper, 12 tin.

**Strength of the Copper-zinc Alloys.** — The alloys containing less than 15% of zinc by original mixture were generally defective. The bars were full of blow-holes, and the metal showed signs of oxidation. To insure good castings it appears that copper-zinc alloys should contain more than 15% of zinc.

From No. 2 to No. 8 inclusive, 16.98 to 30.06% zinc the bars show a remarkable similarity in all their properties. They have all nearly the same strength and ductility, the latter decreasing slightly as zinc increases, and are nearly alike in color and appearance. Between Nos. 8 and 10, 30.06 and 36.36% zinc, the strength by all methods of test rapidly increases. Between No. 10 and No. 15, 36.36 and 50.14% zinc, there is another group, distinguished by high strength and diminished ductility. The alloy of maximum tensile, transverse and torsional strength contains about 41% of zinc.

The alloys containing less than 55% of zinc are all yellow metals. Beyond 55% the color changes to white, and the alloy becomes weak and brittle. Between 70% and pure zinc the color is bluish gray, the brittleness decreases and the strength increases, but not to such a degree as to make them useful for constructive purposes.

**Difference between Composition by Mixture and by Analysis.** — There is in every case a smaller percentage of zinc in the average analysis than in the original mixture, and a larger percentage of copper. The loss of zinc is variable, but in general averages from 1 to 2%.

**Liquation or Separation of the Metals.** — In several of the bars a considerable amount of liquation took place, analysis showing a difference in composition of the two ends of the bar. In such cases the change in composition was gradual from one end of the bar to the other, the upper end in general containing the higher percentage of copper. A notable instance was bar No. 13, in the above table, turnings from the upper end containing 40.36% of zinc, and from the lower end 48.52%.

**Specific Gravity.** — The specific gravity follows a definite law, varying with the composition, and decreasing with the addition of zinc. From the plotted curve of specific gravities the following mean values are taken:

Per cent zinc . . . . .	0	10	20	30	40	50	60	70	80	90	100
Specific gravity . . . . .	8.80	8.72	8.60	8.40	8.36	8.20	8.00	7.72	7.40	7.20	7.14

**Graphic Representation of the Law of Variation of Strength of Copper-Tin-Zinc Alloys.** — In an equilateral triangle the sum of the perpendicular distances from any point within it to the three sides is equal to the altitude. Such a triangle can therefore be used to show graphically the percentage composition of any compound of three parts, such as a triple alloy. Let one side represent 0 copper, a second 0 tin, and the third 0 zinc, the vertex opposite each of these sides representing 100 of each element respectively. On points in a triangle of wood representing different alloys tested, wires were erected of lengths proportional to the tensile strengths, and the triangle then built up with plaster to the height of the wires. The surface thus formed has a characteristic topography representing the variations of strength with variations of composition. The cut shows the surface thus made. The vertical section to the left represents the law of tensile strength of the copper-tin alloys, the one to the right that of tin-zinc alloys, and the one at the rear that of the copper-zinc alloys. The high point represents the strongest possible alloys of the three metals. Its composition is copper 55, zinc 43, tin 2, and its strength about 70,000 lbs. The high ridge from this point to the point of maximum height of the section on the left is the line of the strongest alloys, represented by the formula  $\text{zinc} + (3 \times \text{tin}) = 55$ .

All alloys lying to the rear of the ridge, containing more copper and less tin or zinc are alloys of greater ductility than those on the line of

maximum strength, and are the valuable commercial alloys; those in front on the declivity toward the central valley are brittle, and those in the valley are both brittle and weak. Passing from the valley toward the section at the right the alloys lose their brittleness and become soft, the maximum softness being at tin=100, but they remain weak, as is shown by the low elevation of the surface. This model was planned and constructed by Prof. Thurston in 1877. (See *Trans. A. S. C. E.*, 1881. Report of the U. S. Board appointed to test Iron, Steel, etc., vol. ii, Washington, 1881, and Thurston's *Materials of Engineering*, vol. iii.)

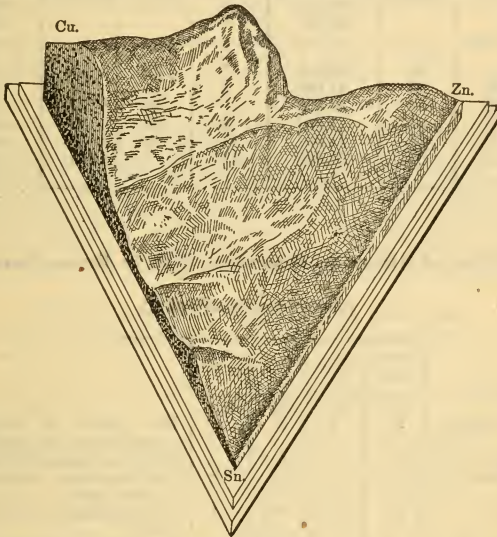

FIG. 90.

The best alloy obtained in Thurston's research for the U. S. Testing Board has the composition, copper 55, tin 0.5, zinc 44.5. The tensile strength in a cast bar was 68,900 lbs. per sq. in., two specimens giving the same result; the elongation was 47 to 51 per cent in 5 inches. Thurston's formula for copper-tin-zinc alloys of maximum strength (*Trans. A. S. C. E.*, 1881) is  $z + 3t = 55$ , in which  $z$  is the percentage of zinc and  $t$  that of tin. Alloys proportioned according to this formula should have a strength of about 40,000 lbs. per sq. in. + 500  $z$ . The formula fails with alloys containing less than 1 per cent of tin.

The following would be the percentage composition of a number of alloys made according to this formula, and their corresponding tensile strength in castings:

Tin.	Zinc.	Copper.	Tensile Strength, lbs. per sq. in.	Tin.	Zinc.	Copper.	Tensile Strength lbs. per sq. in.
1	52	47	66,000	8	31	61	55,500
2	49	49	64,500	9	28	63	54,000
3	46	51	63,000	10	25	65	52,500
4	43	53	61,500	12	19	69	49,500
5	40	55	60,000	14	13	73	46,500
6	37	57	58,500	16	7	77	43,500
7	34	59	57,000	18	1	81	40,500



These alloys, while possessing maximum tensile strength, would in general be too hard for easy working by machine tools. Another series made on the formula  $z + 4t = 50$  would have greater ductility, together with considerable strength, as follows, the strength being calculated as before, tensile strength in lbs. per sq. in. =  $40,000 + 500z$ .

Tin.	Zinc.	Copper.	Tensile Strength, lbs. per sq. in.	Tin.	Zinc.	Copper.	Tensile Strength, lbs. per sq. in.
1	46	53	63,000	7	22	71	51,000
2	42	56	61,000	8	18	74	49,000
3	38	59	59,000	9	14	77	47,000
4	34	62	57,000	10	10	80	45,000
5	30	65	55,000	11	6	83	43,000
6	26	68	53,000	12	2	86	41,000

### Composition of Alloys in Every-day Use in Brass Foundries.

(*American Machinist.*)

	Cop- per.	Zinc.	Tin.	Lead.	
	lbs.	lbs.	lbs.	lbs.	
Admiralty metal..	87	5	8	.....	For parts of engines on board naval vessels.
Bell metal.....	16	.....	4	.....	Bells for ships and factories.
Brass (yellow).....	16	8	.....	1/2	For plumbers, ship and house brass work.
Bush metal.....	64	8	4	4	For bearing bushes for shafting.
Gun metal.....	32	1	3	.....	For pumps and other hydraulic purposes.
Steam metal.....	20	1	1 1/2	1	Castings subjected to steam pressure.
Hard gun metal...	16	.....	2 1/2	.....	For heavy bearings.
Muntz metal.....	60	40	.....	.....	Metal from which bolts and nuts are forged, valve spindles, etc.
Phosphor bronze..	92	.....	8 phos. tin		For valves, pumps and general work.
“ “ ..	90	.....	10 “ “		For cog and worm wheels, bushes, axle bearings, slide valves, etc.
Brazing metal.....	16	3	.....	.....	Flanges for copper pipes.
“ solder.....	50	50	.....	.....	Solder for the above flanges.

**Admiralty Metal**, for surface condenser tubes where sea water is used for cooling, Cu, 70; Zn, 29; Sn, 1. *Power*, June 1, 1909.

**Gurley's Bronze**. — 16 parts copper, 1 tin, 1 zinc, 1/2 lead, used by W & L. E. Gurley of Troy for the framework of their engineer's transits. Tensile strength 41,114 lbs. per sq. in., elongation 27% in 1 inch, sp. gr. 8.696. (W. J. Keep, *Trans. A. I. M. E.*, 1890.)



Composition of Various Grades of Rolled Brass, Etc.

Trade Name.	Copper.	Zinc.	Tin.	Lead.	Nickel.
Common high brass.....	61.5	38.5	...	...	...
Yellow metal.....	60	40	...	...	...
Cartridge brass.....	66 2/3	33 1/3	...	...	...
Low brass.....	80	20	...	...	...
Clock brass.....	60	40	...	1 1/2	...
Drill rod.....	60	40	...	1 1/2 to 2	...
Spring brass.....	66 2/3	33 1/3	1 1/2	...	...
18 per cent German silver.....	61 1/2	20 1/2	...	...	18

The above table was furnished by the superintendent of a mill in Connecticut in 1894. He says: While each mill has its own proportions for various mixtures, depending upon the purposes for which the product is intended, the figures given are about the average standard. Thus, between cartridge brass with 33 1/3 per cent zinc and common high brass with 38 1/2 per cent zinc, there are any number of different mixtures known generally as "high brass," or specifically as "spinning brass," "drawing brass," etc., wherein the amount of zinc is dependent upon the amount of scrap used in the mixture, the degree of working to which the metal is to be subjected, etc.

Useful Alloys of Copper, Tin, and Zinc.

(Selected from numerous sources.)

	Copper.	Tin.	Zinc.
U. S. Navy Dept. journal boxes } and guide-gibs. .... }	{ 6 82.8	{ 1 13.8	{ 1/4 parts. 3.4 per cent.
Tobin bronze.....	58.22	2.30	39.48 " "
Naval brass.....	62	1	37 " "
Composition, U. S. Navy.....	88	10	2 " "
Brass bearings (J. Rose).....	{ 64 87.7	{ 8 11.0	{ 1 parts. 1.3 per cent
Gun metal.....	92.5	5	2.5 " "
" " .....	91	7	2 " "
" " .....	87.75	9.75	2.5 " "
" " .....	85	5	10 " "
" " .....	83	2	15 " "
Tough brass for engines.....	{ 13 76.5	{ 2 11.8	{ 2 parts. 11.7 per cent.
Bronze for rod-boxes (Lafond).....	82	16	2 slightly malleable.
" " pieces subject to shock..	83	15	1.50 0.50 lead.
Red brass..... parts	20	1	1 1 " "
" " .....	87	4.4	4.3 4.3 " "
Bronze for pump casings (Lafond)..	88	10	2
" " eccentric straps. "	84	14	2
" " shrill whistles.....	80	18	..... 2.0 antimony.
" " low-toned whistles.....	81	17	..... 2.0 " "
Art bronze, dull red fracture.....	97	2	1
Gold bronze.....	89.5	2.1	5.6 2.8 lead.
Bearing metal.....	89	8	3
" " .....	89	21 1/2	81 1/2
" " .....	86	14	.....
" " .....	85 1/4	12 3/4	2
" " .....	80	18	2
" " .....	79	18	21 1/2 1/2 lead.
" " .....	74	9 1/2	9 1/2 7 lead.
English brass of A.D. 1504 .....	64	3	29 1/2 31 1/2 lead.

**"Steam Metal."** Alloys of copper and zinc are unsuitable for steam valves and other like purposes, since their strength is greatly reduced at high temperatures, and they appear to undergo a deterioration by continued heating. Alloys of copper with from 10 to 12% of tin, when cast without oxidation, are good steam metals, and a favorite alloy is what is known as "government mixture," 88 Cu, 10 Sn, 2 Zn. It has a tensile strength of about 33,000 lb. per sq. in., when cold, and about 30,600 lb. when heated to 407° F., corresponding to steam of 250 lb. pressure.

Analyses of Tobin bronze by Dr. Chas. B. Dudley gave the following:  
Pig metal. . . . . Cu, 59.00; Zn, 38.40; Sn, 2.16; Fe, 0.11; Pb, 0.31  
Rolled bar. . . . . Cu, 61.20; Zn, 37.14; Sn, 0.90; Fe, 0.18; Pb, 0.35

The rolled bar gave 78,500 lb. tensile strength, 40% elongation in 2 in. and 15% in 8 in.

The original Tobin bronze in 1875, as described by Thurston, *Trans. A. S. C. E.*, 1881, had copper 58.22, tin 2.30, zinc 39.48. As cast it had a tenacity of 66,000 lb. per sq. in., and as rolled 79,000 lb.; cold rolled it gave 104,000 lb.

At a cherry-red heat Tobin bronze can be forged and stamped as readily as steel. Its great tensile strength and its resistance to the corrosive action of sea water make it a suitable metal for condenser plates and other marine purposes.

**Miscellaneous Alloys.** (From a circular of the Titanium Alloy Mfg. Co., Niagara Falls, N. Y., 1915.)

ANALYSES (Approximate). PHYSICAL QUALITIES (Averages).

No.	Cu.	Al.	Sn.	Zn.	Pb.	T.S.	Elong. in 2 In.	Specific Gravity.	Brinell Hardness.	Shrinkage, In. per Ft.	Weight per Cu. In.	Compres- sion, El. Limit.
1	90	10	....	....	....	70,000	20	7.5	95	0.22	0.27	19,500
3	89	....	11	....	....	37,500	8	8.5	75	.125	.31	21,600
5	90	10	....	....	....	77,000	24.5	7.5	94	.22	.27	25,000
9	90	....	10	....	....	37,500	17.5	8.6	67	.125	.31	....
10	88	....	10	2	....	35,000	16	8.7	72	.125	.32	....
11	90	....	6.5	2	1.5	37,000	29	8.8	55	.14	.32	....
14	88	....	10	....	2	32,500	6.5	8.8	67	.125	.32	18,500
15	80	....	10	....	10	30,000	6	9.0	57	.125	.33	....
16	81	....	7	3	9	32,500	17	8.9	52	.125	.33	....
18	85	....	5	5	5	30,000	18	8.5	55	.14	.31	....
19	83	....	4	7	6	30,500	17.5	8.5	57	.125	.31	....
24	70	....	1	27	2	29,500	25	8.4	52	.186	.30	....
28	99.75	....	....	....	....	18,500	10	8.8	35	.25	.32	....
29	56	0.5	....	43.5	....	70,000	28.5	8.4	111	.25	.30	30,000
32	8	92	....	....	....	18,000	1.5	2.8	52	.186	.10	....
33	3	82	....	15	....	23,000	2	3.1	62	.186	.11	....

Qualities and Uses:

No. 1. Strength, toughness, resists corrosion.

No. 3. Gear bronze; serviceable for worm wheels running against highly finished steel.

No. 5. Similar to No. 1, but more easily machined. For large, heavy work.

No. 9. Acid resisting; for mine-pump bodies, and for thrust collars or disks.

No. 10. "Gun metal"; for heavy pressures and high speeds; for high-grade bearings.

No. 11. Medium soft bronze; for small bearings lined with babbitt; for steam work.

No. 14. Gear bronze, softer than No. 3; machines more easily.

No. 15. Phosphor bronze; for high speed and heavy pressure; for bearings subject to shock.

No. 16. Similar to No. 15, but somewhat softer and lower in price.

No. 18. High grade red brass; a good steam metal.



- No. 19. Commercial red brass.  
 No. 24. A good yellow brass; casts well; takes a high polish.  
 No. 28. Pure copper, deoxidized; high electrical conductivity.  
 No. 29. "Manganese bronze"; for propeller blades, valve stems and other parts requiring high strength; not good for bearings.  
 No. 32. Standard aluminum alloy; for crank cases, automobile castings, etc.  
 No. 33. Tougher than No. 32; takes an extra high polish, can be bent slightly without breaking.

**Special Alloys.** (*Engineering*, March 24, 1893.)

JAPANESE ALLOYS for art work:

	Copper.	Silver.	Gold.	Lead.	Zinc.	Iron.
Shaku-do.....	94.50	1.55	3.73	0.11	trace.	trace.
Shibu-ichi.....	67.31	32.07	traces.	0.52		

GILBERT'S ALLOY for *cera-perduta* process, for casting in plaster of paris.

Copper 91.4      Tin 5.7      Lead 2.9      Very fusible.

**COPPER-ZINC-IRON ALLOYS.**

(F. L. Garrison, *Jour. Frank. Inst.*, June and July, 1891.)

**Delta Metal.** — This alloy, which was formerly known as *sterro-metal*, is composed of about 60 copper, from 34 to 44 zinc, 2 to 4 iron, and 1 to 2 tin.

The peculiarity of all these alloys is the content of iron, which appears to have the property of increasing their strength to an unusual degree. In making delta metal the iron is previously alloyed with zinc in known and definite proportions. When ordinary wrought-iron is introduced into molten zinc, the latter readily dissolves or absorbs the former, and will take it up to the extent of about 5% or more. By adding the zinc-iron alloy thus obtained to the requisite amount of copper, it is possible to introduce any definite quantity of iron up to 5% into the copper alloy. Garrison gives the following as the range of composition of copper-zinc-iron, and copper-zinc-tin-iron alloys:

I.		II.	
	Per cent.		Per cent.
Iron.....	0.1 to 5	Iron.....	0.1 to 5
Copper.....	50 to 65	Tin.....	0.1 to 10
Zinc.....	49.9 to 30	Zinc.....	1.8 to 45
		Copper.....	98 to 40

The advantages claimed for delta metal are great strength and toughness. It produces sound castings of close grain. It can be rolled and forged hot, and can stand a certain amount of drawing and hammering when cold. It takes a high polish, and when exposed to the-atmosphere tarnishes less than brass.

When cast in sand delta metal has a tensile strength of about 45,000 pounds per square inch, and about 10% elongation; when rolled, tensile strength of 60,000 to 75,000 pounds per square inch, elongation from 9% to 17% on bars 1.128 inch in diameter and 1 inch area.

Wallace gives the ultimate tensile strength 33,600 to 51,520 pounds per square inch, with from 10% to 20% elongation.

Delta metal can be forged, stamped and rolled hot. It must be forged at a dark cherry-red heat, and care taken to avoid striking when at a black heat.

According to Lloyd's Proving House tests, made at Cardiff, December 20, 1887, a half-inch delta metal-rolled bar gave a tensile strength of 88,400 pounds per square inch, with an elongation of 30% in three inches.

## ALLOYS OF COPPER, TIN, AND LEAD.

G. H. Clamer, in *Castings*, July, 1908, describes some experiments on the use of lead in copper alloys. A copper and lead alloy does not make what would be called good castings; by the introduction of tin a more homogeneous product is secured. By the addition of nickel it was found that more than 15% of lead could be used, while maintaining tin at 8 to 10%, and also that the tin could be dispensed with. A good alloy for bearings was then made without nickel, containing Cu 65, Sn 5, Pb 30. This alloy is largely sold under the name of "plastic bronze." If the matrix of tin and copper were so proportioned that the tin remained below 9% then more than 20% of lead could be added with satisfactory results. As the tin is decreased more lead may be added. (See Bearing Metal Alloys, below.)

**The Influence of Lead on Brass.** — E. S. Sperry, *Trans. A.I.M.E.*, 1897. As a rule, the lower the brass (that is, the lower in zinc) the more difficult it is to cut. If the alloy is made from pure copper and zinc, the chips are long and tenacious, and a slow speed must be employed in cutting. For some classes of work, such as spinning or cartridge brass, these qualities are essential, but for others, such as clock brass or screw rod, they are almost prohibitory. To make an alloy which will cut easily, giving short chips, the best method is the addition of a small percentage of lead. Experiments were made on alloys containing different percentages of lead. The following is a condensed statement of the chief results:

Cu, 60; Zn, 30; Pb, 10. Difficult to obtain a homogeneous alloy. Cracked badly on rolling.

Cu, 60; Zn, 35; Pb, 5. Good cutting qualities but cracked on rolling.

Cu, 60; Zn, 37.5; Pb, 2.5. Cutting qualities excellent, but could only be hot-rolled or forged with difficulty.

Cu, 60; Zn, 38.75; Pb, 1.25. Cutting qualities inferior to those of the alloy containing 2.5% of lead, but superior to those of pure brass.

Cu, 60; Zn, 40. Perfectly homogeneous. Rolls easily at a cherry red heat, and cracks but slightly in cold rolling. Chips long and tenacious, necessitating a slow speed in cutting.

Tensile tests of these alloys gave the following results:

Copper, %	60.0			60.0			60.0			60.0		
	C	A	H	C	A	H	C	A	H	C	A	H
Zinc, %	40.0			37.5			35.0			30.0		
Lead, %	None.			2.5			5.0			10.0		
T.S. per sq. in.*	16	60	107	39	51	88	33	42	61	36	35	63
Elong. in 1 in., %	48	51	1	28	27	0	28	26	1	36	20	2
Elong. in 8 in., %	27	33	0	27	23	0	27	22	0	30	16	3
Red. of area, %	61	44	13	30	33	0	26	33	0	29	25	4
P.R.	92%			65%			61%			38%		

\* Thousands of pounds. C, casting; A, annealed sheet; H, hard rolled sheet; P. R., possible reduction in rolling.

The use of tin, even in small amounts, hardens and increases the tensile strength of brass, which is detrimental to free turning. Mr. Sperry gives analyses of several brasses which have given excellent results in turning, all included within the following range: Cu, 60 to 66%, Zn, 38 to 32%, Pb, 1.5 to 2.5%. For cartridge-brass sheet, anything over 0.10% of lead increases the liability of cracking in drawing.

## PHOSPHOR-BRONZE AND OTHER SPECIAL BRONZES.

**Phosphor-bronze.** — In the year 1868, Montefiore & Kunzel of Liege, Belgium, found by adding small proportions of phosphorus or "phosphoret of tin or copper" to copper that the oxides of that metal, nearly always present as an impurity, more or less, were deoxidized and the copper much improved in strength and ductility, the grain of the fracture became finer, the color brighter, and a greater fluidity was attained.



Three samples of phosphor-bronze, tested by Kirkaldy, gave

Elastic limit, lbs. per sq. in. . . . .	23,800	24,700	16,100
Tensile strength, lbs. per sq. in. . .	52,625	46,100	44,448
Elongation, per cent. . . . .	8.40	1.50	33.40

The strength of phosphor-bronze varies like that of ordinary bronze according to the percentages of copper, tin, zinc, lead, etc., in the alloy.

**Phosphor-bronze Rod.** — Torsion tests of 20 samples, 1/4 in. diam. Apparent outside fiber stress, 77,500 to 86,700 lbs. per sq. in.; average number of turns per inch of length, 0.76 to 1.50. — *Tech. Quar.*, vol. xii, Sept., 1899.

**Penn. R. R. Co.'s Specifications for Phosphor-bronze (1902).** — The metal desired is a homogeneous alloy of copper, 79.70; tin, 10.00; lead, 9.50; phosphorus, 0.80. Lots will not be accepted if samples do not show tin, between 9 and 11%; lead, between 8 and 11%; phosphorus, between 0.7 and 1%; nor if the metal contains a sum total of other substances than copper, tin, lead, and phosphorus in greater quantity than 0.50 per cent. (See also p. 406.)

**Deoxidized Bronze.** — This alloy resembles phosphor bronze somewhat in composition and also delta metal, in containing zinc and iron. The following analysis gives its average composition: Cu, 82.67; Sn, 12.40; Zn, 3.23; Pb, 2.14; Fe, 0.10; Ag, 0.07; P, 0.005.

**Comparison of Copper, Silicon-bronze, and Phosphor-bronze Wires.** (*Engineering*, Nov. 23, 1883.)

Description of Wire.	Tensile Strength.	Relative Conductivity.
Pure copper . . . . .	39,827 lbs. per sq. in.	100 per cent.
Silicon bronze (telegraph) . . . . .	41,696 " " " "	96 " "
" " (telephone) . . . . .	108,080 " " " "	34 " "
Phosphor bronze (telephone) . . . . .	102,390 " " " "	26 " "

**Silicon Bronze.** (*Aluminum World*, May, 1897.)

The most useful of the silicon bronzes are the 3% (97% copper, 3% silicon) and the 5% (95% copper, 5% silicon), although the hardness and strength of the alloy can be increased or decreased at will by increasing or decreasing silicon. A 3% silicon bronze has a tensile strength, in a casting, of about 55,000 lbs. per sq. in., and from 50% to 60% elongation. The 5% bronze has a tensile strength of about 75,000 lbs. and about 8% elongation. More than 5% or 5 1/2% of silicon in copper makes a brittle alloy. In using silicon, either as a flux or for making silicon bronze, the rich alloy of silicon and copper which is now on the market should be used. It should be free from iron and other metals if the best results are to be obtained. Ferro-silicon is not suitable for use in copper or bronze mixtures.

**Copper and Vanadium Alloys.** The Vanadium Sales Co. of America reports (1908) that the addition of vanadium to copper has given a tensile strength of 83,000 lbs. per sq. in.; with an elongation of over 60%.

**ALLOYS FOR CASTING UNDER PRESSURE IN METAL MOLDS.** E. L. Lake, *Am. Mach.*, Feb. 13, 1908.

No.	Tin.	Copper.	Alumi-num.	Zinc.	Lead.	Anti-mony.	Iron
1	14.75	5.25	6.25	73.75	.....	.....	.....
2	19	5	1.	72.7	2	0.3	.....
3	12	10.6	3.4	73.8	.....	.....	0.2
4	30.8	20.4	2.6	46.2	.....	.....	.....

Nos. 1 and 2 suitable for ordinary work, such as could be performed by average brass castings. No. 3 and 4 are harder.

## ALUMINUM ALLOYS.

The useful alloys of aluminum so far found have been chiefly in two groups, the one of aluminum with not more than 35% of other metals, and the other of metals containing not over 15% of aluminum; in the one case the metals impart hardness and other useful qualities to the aluminum, and in the other the aluminum gives useful qualities to the metal with which it is alloyed.

**Aluminum-Copper Alloys.** — The useful aluminum-copper alloys can be divided into two classes, — the one containing less than 11% of aluminum, and the other containing less than 15% of copper. The first class is best known as Aluminum Bronze.

**Aluminum Bronze.** (Cowles Electric Smelting and Al. Co.'s circular.) The standard A No. 2 grade of aluminum bronze, containing 10% of aluminum and 90% of copper, has many remarkable characteristics which distinguish it from all other metals.

The tenacity of castings of A No. 2 grade metal varies between 75,000 and 90,000 lbs. to the square inch, with from 4% to 14% elongation.

Increasing the proportion of aluminum in bronze beyond 11% produces a brittle alloy; therefore nothing higher than the A No. 1, which contains 11%, is made.

The B, C, D, and E grades, containing 7½%, 5%, 2½%, and 1¼% of aluminum, respectively, decrease in tenacity in the order named, that of the former being about 65,000 pounds, while the latter is 25,000 pounds. While there is also a proportionate decrease in transverse and torsional strengths, elastic limit, and resistance to compression as the percentage of aluminum is lowered and that of copper raised, the ductility, on the other hand, increases in the same proportion. The specific gravity of the A No. 1 grade is 7.56.

• Bell Bros., Newcastle, gave the specific gravity of the aluminum bronzes as follows:

3%, 8.691; 4%, 8.621; 5%, 8.369; 10%, 7.689.

In manufacturing aluminum bronze, only the purest metals should be used. The copper should be melted over a gas or oil fire in a plum-bago crucible, being covered with charcoal to prevent oxidation and the absorption of gases. If a coal fire is used, the copper will absorb gases from the coal and produce an unsatisfactory alloy. The aluminum is dropped through the charcoal into the molten copper. The aluminum combines with the copper as soon as its melting point is reached, setting free latent heat and raising the temperature of the mass. The copper becomes brighter and more liquid when the union takes place, and the crucible then should be instantly removed from the fire, skimmed, and poured into ingot molds of convenient size. The liquid should be stirred until poured. The alloy may then be remelted for casting. Each remelting improves the quality of the aluminum bronze up to about four remeltings. (Aluminum Co. of America, 1909.)

## Tests of Aluminum Bronzes.

(John H. J. Daggar, British Association, 1889.)

Per cent of Aluminum.	Tensile Strength.		Elonga- tion, per cent.	Specific Gravity.
	Tons per square inch.	Pounds per square inch.		
11.....	40 to 45	89,600 to 100,800	8	7.23
10.....	33 " 40	73,920 " 89,600	14	7.69
7½.....	25 " 30	56,000 " 67,200	40	8.00
5-5½.....	15 " 18	33,600 " 40,320	40	8.37
2½.....	13 " 15	29,120 " 33,600	50	8.69
1¼.....	11 " 13	24,640 " 29,120	55	.....

**Castling.**—The melting point of aluminum bronze varies slightly with the amount of aluminum contained, the higher grades melting at a lower temperature than the lower grades. The A No. 1 grades melt at about 1700° F., a little higher than ordinary bronze or brass.

Aluminum bronze shrinks more than ordinary brass. As the metal solidifies rapidly it is necessary to pour it quickly and to make the feeders amply large, so that there will be no "freezing" in them before the casting is properly fed. Baked-sand molds are preferable to green sand, except for small castings, and when fine skin colors are desired in the castings. (Thos. D. West, *Trans. A. S. M. E.*, 1886, vol. viii.)

All grades of aluminum bronze can be rolled, swedged, spun, or drawn cold except A 1 and A 2. They can all be worked at a bright red heat.

In rolling, swedging, or spinning cold, it should be annealed very often and at a brighter red heat than is used for annealing brass.

**Seamless Tubes.**—Leonard Waldo, *Trans. A. S. M. E.*, vol. xviii, describes the manufacture of aluminum bronze seamless tubing. Many difficulties were met in all stages of the process. A cold drawn bar, 1.49 in. outside diameter, 0.05 in. thick, showed a yield point of 68,700, and a tensile strength of 96,000 lb. per sq. in. with an elongation of 4.9% in 10 in.; heated to bright red and plunged in water, the yield point reduced to 24,200 and the T. S. to 47,600 lb. per sq. in., and the elongation in 10 in. increased to 64.9%.

**Brazing.**—Aluminum bronze will braze as well as any other metal, using one-quarter brass solder (zinc 500, copper 500) and three-quarters borax, or, better, three-quarters cryolite.

**Soldering.**—Aluminum bronze can be soldered by using a solder of pure block tin with a flux of zinc filings and muriatic acid. It is advisable to "tin" the two surfaces before putting them together.

**Aluminum Brass.**—(E. H. Cowles, *Trans. A. I. M. E.*, vol. xviii.)—Cowles aluminum brass is made by fusing together equal weights of A 1 aluminum bronze, copper, and zinc. The copper and bronze are first thoroughly melted and mixed, and the zinc is finally added. The material is left in the furnace until small test-bars are taken from it and broken. When these bars show a tensile strength of 80,000 pounds or over, with 2 or 3 per cent ductility, the metal is ready to be poured. Tests of this brass, on small bars, have at times shown as high as 100,000 pounds tensile strength.

The Aluminum Co. of America says (1909) that aluminum brass has an elastic limit of about 30,000 lb. per sq. in., an ultimate strength of 40,000 to 50,000 lb. per sq. in., and an elongation of 3% to 10% in 8 in. Aluminum brass is used with aluminum ranging from 0.1% to 10%. The best results are obtained by introducing the aluminum in the form of aluminized zinc, a 5% aluminized zinc being used where less than 1% of aluminum is required and a 10% aluminized zinc for aluminum percentages of over 1%. The effect of aluminum in brass in quantities of less than 1% is to make the brass flow freely and to insure a sounder casting, and it enables from one-half to one-third more castings to be made on a gate than is possible where aluminum is not used. In quantities over 1% up to 10% the aluminum increases the strength of brass, enabling a cheaper grade of brass to be used than would otherwise be possible. Inasmuch as aluminum lowers the melting point of brass, great care must be taken not to overheat it in melting.

### Tests of Aluminum Brass.

(Cowles E. S. & Al. Co.)

Specimen (Castings)	Diameter of Piece, Inch.	Area sq. in.	Tensile Strength, lbs. per sq. in.	Elastic Limit, lbs. per sq. in.	Elongation, per ct.	Remarks.
15% A grade Bronze } 17% Zinc . . . . . } 68% Copper . . . . . }	0.465	0.1698	41,225	17,668	41 1/2	These test pieces were all 6 in. long between the shoulders.
1 part A Bronze . . } 1 part Zinc . . . . . } 1 part Copper . . . . }	0.465	0.1698	78,327	.....	2 1/2	
1 part A Bronze . . } 1 part Zinc . . . . . } 1 part Copper . . . . }	0.460	0.1661	72,246	.....	2 1/2	

The first brass on the above list is an extremely tough metal with low



elastic limit, made purposely so as to "upset" easily. The other, which is called Aluminum brass No. 2, is very hard.

**Caution as to Reported Strength of Alloys.**—The same variation in strength which has been found in tests of gun-metal (copper and tin) noted above, must be expected in tests of aluminum bronze and, in fact, of all alloys. They are exceedingly subject to variation in density and in grain, caused by differences in method of molding and casting, temperature of pouring, size of and shape casting, depth of "sinking head," etc. Chill-castings give higher results than sand-castings, and bars cast by themselves purposely for testing almost invariably run higher than test bars attached to castings. Bars cut out from castings are generally weaker than bars cast alone.

**Effect of Copper on Aluminum.**—Tests of rolled sheets of aluminum, 0.04 in. thick, with varying percentages of copper are reported in *The Engineer*, Jan. 2, 1891, as follows:

Aluminum, per cent. . . . .	100	98	96	94	92
Copper, per cent. . . . .	0	2	4	6	8
Specific gravity, calculated. . . . .		2.78	2.90	3.02	3.14
Specific gravity, determined. . . . .	2.67	2.71	2.77	2.82	2.85
Tensile strength, lb. per sq. in.	25,535	43,563	44,130	54,773	50,374

### Tests of Aluminum Alloys.

(Engineer Harris, U. S. N., *Trans. A. I. M. E.*, vol. xviii.)

Composition.					Tensile Strength per sq. in., lb.	Elastic Limit, lb. per sq. in.	Elongation, per ct.	Reduction of Area, per ct.
Copper.	Aluminum.	Silicon.	Zinc.	Iron.				
91.50%	6.50%	1.75%	.....	0.25%	60,700	18,000	23.2	30.7
88.50	9.33	1.66	.....	0.50	66,000	27,000	3.8	7.8
91.50	6.50	1.75	.....	0.25	67,600	24,000	13	21.62
90.00	9.00	1.00	.....	.....	72,830	33,000	2.40	5.78
63.00	3.33	0.33	33.33%	.....	82,200	60,000	2.33	9.88
63.00	3.33	0.33	33.33%	.....	70,400	55,000	0.4	4.33
91.50	6.50	1.75	.....	0.25	59,100	19,000	15.1	23.59
93.00	6.50	0.50	.....	.....	53,000	19,000	6.2	15.5
88.50	9.33	1.66	.....	0.50	69,930	33,000	1.33	3.30
92.00	6.50	0.50	.....	.....	46,530	17,000	7.8	19.19

For comparison with the above 6 tests of "Navy Yard Bronze," Cu 88, Sn 10, Zn 2, are given in which the T. S. ranges from 18,000 to 24,590, E. L. from 10,000 to 13,000, El. 2.5 to 5.8%, Red. 4.7 to 10.89.

### Alloys of Aluminum, Silicon and Iron.

M. and E. Bernard have succeeded in obtaining through electrolysis, by treating directly and without previous purification, the aluminum earths (red and white bauxites), the following:

Alloys such as ferro-aluminum, ferro-silicon-aluminum, and silicon-aluminum, where the proportion of silicon may exceed 10%, which are employed in the metallurgy of iron for refining steel and cast-iron.

Also silicon-aluminum, where the proportion of silicon does not exceed 10%, which may be employed in mechanical constructions in a rolled or hammered condition, in place of steel, on account of their great resistance, especially where the lightness of the piece in construction constitutes one of the main conditions of success.

The following analyses are given:

1. Alloys applied to the metallurgy of iron, the refining of steel and cast iron: No. 1, Al, 70%; Fe, 25%; Si, 5%. No. 2, Al, 70; Fe, 20; Si, 10. No. 3, Al, 70; Fe, 15; Si, 15. No. 4, Al, 70; Fe, 10; Si, 20. No. 5, Al, 70; Fe, 10; Si, 10; Mn, 10. No. 6, Al, 70; Fe, trace; Si, 20; Mn, 10.

2. Mechanical alloys: No. 1, Al, 92; Si, 6.75; Fe, 1.25. No. 2, Al, 90; Si, 9.25; Fe, 0.75. No. 3, Al, 90; Si, 10; Fe, trace. The best results were with alloys where the proportion of iron was very low, and the proportion of silicon in the neighborhood of 10%. Above that proportion the alloy becomes crystalline and can no longer be employed.



The density of the alloys of silicon is approximately the same as that of aluminum.—*La Metallurgie*, 1892.

**Aluminum-Tungsten Alloys** have been somewhat used in Europe in the form of rolled sheets under the trade name of Wolframium. An aluminum-tungsten alloy used in France (1898) for motor-car bodies has the following properties: Cast, sp. gr. 2.86; T.S., 17,000 to 24,000; elong., 12 to 6%. Rolled, sp. gr., 3.09; T.S., 45,500 to 53,600; elong., 8 to 6%.

**Aluminum-Antimony** alloys have been produced, but have a scientific rather than a commercial interest. The alloy whose composition is Sb Al has a higher melting point than either of its constituents.

**Aluminum and Manganese.**—Manganese is one of the best hardeners of aluminum. Professor Carpenter found that it increased the strength when added in quantities up to 10%.

**Undesirable Aluminum Alloys.**—While aluminum will combine with all the metalloids and gaseous elements, such as oxygen, nitrogen, sulphur, selenium, chlorine, iodine, boron, silicon, and carbon, no useful result has been recorded from the combination of metallic aluminum with any of these elements. The prevention of the occlusion of gaseous metalloids in molten aluminum and the prevention of the union of carbon and aluminum are among the chief precautions to be observed in the metallurgy of aluminum. The effect of sodium and potassium on aluminum is as undesirable as the effect of phosphorus and sulphur on steel. (Aluminum Co. of America.)

**Aluminum-Magnesium.**—**Magnalium.**—A patented alloy of aluminum and magnesium, containing 90 to 98% Al has the trade name "magnalium." It is lighter than aluminum (sp. gr. 2.5), and is whiter, harder, and stronger. It can be forged, rolled, drawn, machined, and filed. It resists oxidation better than other light metals or alloys. Tensile strength: cast, 18,400 to 21,300 lb. per sq. in., with a reduction of area 3.75%; rolled, 52,200 lb. per sq. in., with a reduction of area of 3.7%; annealed, 42,200 lb. per sq. in., reduction, 17.8%. Al Mg alloys are said by the Aluminum Co. of America to be as strong as Al Cu alloys.

**Aluminum and Iron.**—Aluminum alloys with cast-iron up to 15% Al, but the metal decreases in strength as the Al increases. Above 15% Al the alloys are granular and have practically no coherence. (*Trans. A. I. M. E.*, vol. xviii, *A. S. M. E.*, vol. xix.) It is doubtful if aluminum has much effect on soft gray No. 1 foundry iron, except to keep the metal molten a longer time. With difficult castings, where loss is occasioned by defective castings or where the iron does not flow freely, the addition of aluminum will improve the quality of the casting, and give a closer grained iron. The addition of 2% or more of Al will decrease the shrinkage of cast iron. In wrought iron, 1% Al makes the metal more fluid at 2200° F. than it would be at 3500° F. without Al. An addition of 0.25% Al to the bath causes the charge to stiffen more quickly. (Aluminum Co. of America, 1909.)

**Aluminum, Copper, and Tin.**—Prof. R. C. Carpenter, *Trans. A. S. M. E.*, vol. xix., finds the following alloys of maximum strength in a series in which two of the three metals are in equal proportions:

Al, 85; Cu, 7.5; Sn, 7.5; tensile strength, 30,000 lb. per sq. in.; elongation in 6 in., 4%; sp. gr., 3.02. Al, 6.25; Cu, 87.5; Sn, 6.25; T. S., 63,000; El., 3.8; sp. gr., 7.35. Al, 5; Cu, 5; Sn, 90; T. S., 11,000; El., 10.1; sp. gr., 6.82.

From 85 to 95% Cu the bars have considerable strength, are close grained and of a golden color. Between 78 and 80% the color changes to silver white and the bars become brittle. From 78 to 20% Cu the alloys are very hard and brittle, and worthless for practical purposes. Aluminum is strengthened by the addition of equal parts of copper and tin up to 7.5% of each, beyond which the strength decreases. All the alloys that contain between 20 and 60% of either one of the three metals are very weak.

**Aluminum and Zinc.**—(Aluminum Co. of America, 1909.) Like the copper alloys, the zinc alloys can be divided into two classes, (1) those containing a relatively small amount of aluminum, and (2) those containing less than 35% of zinc. The first class is known as "aluminized zinc," and the second comprises the zinc casting alloys. Zinc produces the strongest alloy of aluminum, which strength can be increased by the

addition of other metals. The strongest zinc-aluminum alloy may be as high as 35,000 lb. per sq. in. The high zinc alloys are brittle and more liable to "draw" in heavy parts or lugs than are copper alloys. This can often be overcome by suitable gating, chills, and risers. There is also danger of burning out the zinc and producing a weaker casting. For forging, a zinc-aluminum alloy of 10 to 15% zinc gives excellent results. It is tough, flows well in the dies, is easily machined and is remarkably strong per unit of area.

Aluminized zinc is used in the bath for galvanizing and in aluminum brass. It is made by melting aluminum in the crucible and then gradually stirring in the zinc, after which it is cast into ingots. The 5% alloy is used in the galvanizing bath and for low grade aluminum brass, and the 10% alloy for high-grade brass castings. It is introduced in the molten metal the same as pure zinc. In galvanizing it is added in such proportions that the total amount of aluminum in the bath will be about 1 lb. of aluminum per ton of bath, or about 20 lb. of 5% alloy per ton of bath. It should be added gradually, and as the bath is consumed fresh 5% alloy should be added about 1 lb. at a time for a 5-ton bath. When aluminized zinc is used it is unnecessary to use sal ammoniac to clear the bath of oxide. In starting a new bath, however, after adding the aluminized zinc, it is stirred well until the aluminum combines with the impurities, which rise to the surface as a scum. This is removed, some sal ammoniac is added to counteract the effects of the aluminum, and the proportion of alloy added is reduced.

**Aluminum and Tin.**—(Aluminum Co. of America, 1909.) Tin, alloyed with aluminum in proportions of from 1 to 15%, gives added strength and rigidity to heavy castings, increases the sharpness of outline and decreases shrinkage. The aluminum-tin alloys are rather brittle, and although small proportions of tin in certain casting alloys have been advantageously used to decrease shrinkage, they are comparatively little used on account of the relative cost and brittleness.

**Aluminum and Nickel.**—(Aluminum Co. of America, 1909.) Aluminum-nickel alloys with 2 to 5% of the combined alloying metals are satisfactory for rolling or hammering. A 7 to 9% alloy produces good results in casting.

**Other Aluminum Alloys.**—Al 75.7, Cu. 3, Zn 20, Mn 1.3 is an excellent casting metal, having a tensile strength of over 35,000 lb. per sq. in., and a sp. gr. slightly above 3. It has very little ductility.

Al 96.5, Cu 2, and chromium 1.5 is a little heavier than pure aluminum and has a tensile strength of 26,300 lb. per sq. in. — *A. S. M. E.*, vol. xix.

With the exception of lead and mercury, aluminum unites with all metals, though it unites with antimony with great difficulty. A small percentage of silver whitens and hardens the metal, and gives it added strength; and this alloy is especially applicable to the manufacture of fine instruments and apparatus. The following alloys have been found recently to be useful in the arts: Nickel-aluminum, composed of 20 parts nickel to 80 of aluminum; rosine, made of 40 parts nickel, 10 parts silver, 30 parts aluminum, and 20 parts tin, for jewellers' work; mettaline, made of 35 parts cobalt, 25 parts aluminum, 10 parts iron, and 30 parts copper. The aluminum-bourbouze metal, shown at the Paris Exposition of 1889, has a specific gravity of 2.9 to 2.96, and can be cast in very solid shapes, as it has very little shrinkage. From analysis the following composition is deduced: Aluminum, 85.74%; tin, 12.94%; silicon, 1.32%; iron, none.

**Aluminum Alloys used in Automobile Construction** (*Am. Mach.*, Aug. 22, 1907.)

- |                           |                           |            |
|---------------------------|---------------------------|------------|
| (1) Al 2, Zn, 1,          | T.S. 35,000; Sp. gr. 3.1  |            |
| (2) Al 92, Cu, 8,         | T.S. 18,000; Sp. gr. 2.84 | Ni, trace. |
| (3) Al 83, Zn, 15, Cu, 2, | T.S. 23,000; Sp. gr. 3.1  |            |

(1) Unsatisfactory on account of failures under repeated vibration. (2) Generally used. Resists vibrations well. (3) Used to some extent. Many motor-car makers decline to use it because of uncertainty of its behavior under vibration.

**The Thermit Process.**—When finely divided aluminum is mixed with a metallic oxide and ignited the aluminum burns with great rapidity and intense heat, the chemical reaction being  $Al + Fe_2O_3 = Al_2O_3$



+ Fe. The heat thus generated may be used to fuse or weld iron and other metals. See the Thermit Process, under Welding of Steel, page 488.

**Resistance of Aluminum Alloys to Corrosion.**—J. W. Richards, *Jour. Frank. Inst.*, 1895, gives the following table showing the relative resistance to corrosion of aluminum (99% pure) and alloys of aluminum with different metals, when immersed in the liquids named. The figures are losses per day in milligrams per square centimeter of surface:

	3% Caustic Potash. Cold.	3% Hydro- chloric Acid. Cold.	Strong Nitric Acid. Cold.	Strong Salt Solu- tion. 150° F.	Strong Acetic Acid. 140° F.	Car- bonic Acid. Water. 77° F.
3 per cent copper . . . . .	265.0	53.3	36.1	0.1	0.4	0.0
3 per cent German silver .	1534.4	130.6	97.7	0.05	0.6	0.01
3 per cent nickel . . . . .	580.3	180.0	83.0	0.13	0.75	0.04
2 per cent titanium . . . . .	73.4	4.3	18.6	0.06	0.20	0.0
99 per cent aluminum . . . .	35.6	5.8	9.6	0.04	0.15	0.01

### ALLOYS OF MANGANESE AND COPPER.

**Various Manganese Alloys.**—E. H. Cowles, in *Trans. A. I. M. E.*, vol. xviii, p. 495, states that as the result of numerous experiments on mixtures of the several metals, copper, zinc, tin, lead, aluminum, iron, and manganese, and the metalloid silicon, and experiments upon the same in ascertaining tensile strength, ductility, color, etc., the most important determinations appear to be about as follows:

1. That pure metallic manganese exerts a bleaching effect upon copper more radical in its action even than nickel. In other words, it was found that 18 ½% of manganese present in copper produces as white a color in the resulting alloy as 25% of nickel would do, this being the amount of each required to remove the last trace of red.

2. That upwards of 20% or 25% of manganese may be added to copper without reducing its ductility, although doubling its tensile strength and changing its color.

3. That manganese, copper, and zinc, when melted together and poured into molds behave very much like the most "yeasty" German silver, producing an ingot which is a mass of blow-holes, and which swells up above the mold before cooling.

4. That the alloy of manganese and copper by itself is very easily oxidized.

5. That the addition of 1.25% of aluminum to a manganese-copper alloy converts it from one of the most refractory of metals in the casting process into a metal of superior casting qualities, and the non-corrodibility of which is in many instances greater than that of either German or nickel silver.

A "silver-bronze" alloy especially designed for rods, sheets, and wire has the following composition: Mn, 18; Al, 1.20; Si, 0.5; Zn, 13; and Cu, 67.5%. It has a tensile strength of about 57,000 lbs. on small bars, and 20% elongation. It has been rolled into thin plate and drawn into wire 0.008 inch in diameter. A test of the electrical conductivity of this wire (of size No. 32) shows its resistance to be 41.44 times that of pure copper. This is far lower conductivity than that of German silver.

**Manganese Bronze.** (F. L. Garrison, *Jour. F. I.*, 1891.)—This alloy has been used extensively for casting propeller-blades. Tests of some made by B. H. Cramp & Co., of Philadelphia, gave an average elastic limit of 30,000 lbs. per sq. in., tensile strength of about 60,000 lbs. per sq. in. with an elongation of 8% to 10% in sand castings. When rolled, the E. L. is about 80,000 lbs. per sq. in., tensile strength 95,000 to 106,000 lbs. per sq. in., with an elongation of 12% to 15%.

Compression tests made at United States Navy Department from the metal in the pouring-gate of propeller-hub of U. S. S. Maine gave in two tests a crushing stress of 126,450 and 135,750 lb. per sq. in. The specimens were 1 inch high by 0.7 × 0.7 inch in cross-section = 0.49 square inch. Both specimens gave way by shearing, on a plane making an angle of nearly 45° with the direction of stress.

A test on a specimen 1 × 1 × 1 inch was made from a piece of the

same pouring-gate. Under stress of 150,000 pounds it was flattened to 0.72 inch high by about  $1\frac{1}{4} \times 1\frac{1}{4}$  inches, but without rupture or any sign of distress.

One of the great objections to the use of manganese bronze, or in fact any alloy except iron or steel, for the propellers of iron ships is on account of the galvanic action set up between the propeller and the stern-posts. This difficulty has in great measure been overcome by putting strips of rolled zinc around the propeller apertures in the stern-frames.

The following analysis of Parsons' manganese bronze No. 2 was made from a chip from the propeller of Mr. W. K. Vanderbilt's yacht *Alva*.

Cu, 88.64; Zn, 1.57; Sn, 8.70; Fe, 0.72; Pb, 0.30; P, trace.

It will be observed there is no manganese present and the amount of zinc is very small.

E. H. Cowles, *Trans. A. I. M. E.*, vol. xviii, says: Manganese bronze, so called, is in reality a manganese brass, for zinc instead of tin is the chief element added to the copper. Mr. P. M. Parsons, the proprietor of this brand of metal, has claimed for it a tensile strength of from 24 to 28 tons per sq. in. in small bars when cast in sand.

E. S. Sperry, *Am. Mach.*, Feb. 1, 1906, gives the following analyses of manganese bronze:

	Cu.	Zn.	Fe.	Sn.	Al.	Mn.	Pb.
No. 1.....	60.27	37.52	1.41	0.75	.....	0.01	0.01
" 2.....	56.11	41.34	1.30	0.75	0.47	0.01	0.02
" 3.....	60.00	38.00	1.25	0.65	.....	0.10	.....
" 4.....	56.00	42.38	1.25	0.75	0.50	0.12	.....

No. 1 is Parsons' alloy for sheet, No. 2 for sand casting. No. 3 is Mr. Sperry's formula for sheet, and No. 4 his formula for sand castings. The mixture for No. 3, allowing for volatilization of some zinc is: copper: 60 lbs.; zinc, 39 lbs.; "steel alloy," 2 lbs. That for No. 4 is: copper, 56 lbs.; zinc, 43 lbs.; "steel alloy," 2 lbs.; aluminum, 0.5 lb. The steel alloy is made by melting wrought iron, 18 lbs.; ferro-manganese (80 Fe, 20 Mn), 4 lbs.; tin, 10 lbs. The iron and ferro-manganese are first melted and then the tin is added. In making the bronzes about 15 lbs. of the copper is first melted under charcoal, the steel alloy is added, melted and stirred, then the aluminum is added, melted and stirred, then the rest of the copper is added, and finally the zinc. The only function of the manganese is to act as a carrier to the iron, which is difficult to alloy with copper without such carrier. The iron is needed to give a high elastic limit. Green sand castings of No. 4 frequently give results as high as the following: T. S., 70,000; E. L., 30,000 lbs. per sq. in.; elongation in 6 ins., 18%; reduction of area, 26%.

**Magnetic Alloys of Non-Magnetic Metals.** (*El. World*, April 15, 1905; *Electrot.-Zeit.* Mar. 2, 1905.)—Dr. Heusler has discovered that alloys of manganese, aluminum, and copper are strongly magnetic. The best results have been obtained when the Mn and Al are in the proportions of their respective atomic weights, 55 and 27.1. Two such alloys are described (1) Mn, 26.8; Al, 13.2; Cu, 60. (2) Mn, 20.1; Al, 9.9; Cu, 70, with 1% Pb added. The first was too brittle to be workable. The second was machined without difficulty. These alloys have as yet no commercial importance, as they are far inferior magnetically (at most 1 to 4) to iron.

### GERMAN-SILVER AND OTHER NICKEL ALLOYS.

**German Silver.**—The composition of German silver is a very uncertain thing and depends largely on the honesty of the manufacturer and the price the purchaser is willing to pay. It is composed of copper, zinc, and nickel in varying proportions. The best varieties contain from 18% to 25% of nickel and from 20% to 30% of zinc, the remainder being copper. The more expensive nickel silver contains from 25% to 33% of nickel and from 75% to 66% of copper. The nickel is used as a whitening element; it also strengthens the alloy and renders it harder and more non-corrodible than the brass made without it, of copper and



zinc. Of all troublesome alloys to handle in the foundry or rolling-mill, German silver is the worst. It is unmanageable and refractory at every step in its transition from the crude elements into rods, sheets, or wire. (E. H. Cowles, *Trans. A. I. M. E.*, xviii, p. 494.)

The following list of copper-nickel alloys is from various sources:

	Copper.	Nickel.	Tin.	Zinc.
German silver.....	51.6	25.8	22.6	.....
" ".....	50.2	14.8	3.1	31.9
" ".....	51.1	13.8	3.2	31.9
" ".....	52 to 55	18 to 25	.....	20 to 30
Nickel ".....	75 to 66	25 to 33	.....	.....
Chinese packfong.....	40.4	31.6	.....	6.5 parts
" tutenag.....	8	3	.....	6.5 "
German silver.....	2	1	.....	1 "
" " (cheaper).....	8	2	.....	3.5 "
" " (resembles silver).....	8	3	.....	3.5 "

**Nickel-copper Alloys.**—(F. L. Sperry, *A. I. M. E.*, 1895.)

	Copper.	Nickel.	Zinc.	Iron.	Cobalt.
Berlin.....	52 to 63	22 to 6	26 to 31	.....	.....
French, tableware.....	50	18.7 to 20	31.3 to 30	.....	.....
Mailechort.....	65.4	16.8	13.4	3.4	.....
Christofle.....	50	50	.....	.....	.....
Austrian, tableware.....	50 to 60	25 to 20	25 to 20	.....	.....
English, Sheffield.....	45.7 to 60	31.6 to 15	25.4 to 17	0 to 2.6	0 to 3.4
American, castings.....	52.5	17.7	28.8	.....	.....
" bearings.....	50	25	25	.....	.....
" one-cent coin.....	88	12	.....	.....	.....
Nickel coins.....	75	25	.....	.....	.....

A refined copper-nickel alloy containing 50% copper and 49% nickel, with very small amounts of iron, silicon and carbon, is produced direct from Bessemer matte in the Sudbury (Canada) Nickel Works. German-silver manufacturers purchase a ready-made alloy, which melts at a low heat and requires only the addition of zinc, instead of buying the nickel and copper separately. This alloy, "50-50" as it is called, is almost indistinguishable from pure nickel. Its cost is less than nickel, its melting-point much lower, it can be cast solid in any form desired, and furnishes a casting which works easily in the lathe or planer, yielding a silvery-white surface unchanged by air or moisture. For bullet casings now used in various British and Continental rifles, a special alloy of 80% copper and 20% nickel is made.

**Monel Metal.** — An alloy of about 72% Ni, 1.5 Fe, 26.5 Cu, made from the Canadian copper-nickel ores, is described in the *Metal Worker*, Oct. 10, 1908. It has many valuable properties when rolled into sheets, making it especially suitable for roofing. It is ductile and flexible, is easily soldered, has a high resistance to corrosion, and a relatively small expansion and contraction under temperature changes. The tensile strength in castings is from 70,000 to 80,000 lbs. per sq. in., and in rolled sheets as high as 108,000 lbs.

The Supplee-Biddle Hardware Co.'s Bulletin, Jan., 1915, gives the following results of tests of bars of monel metal. The test pieces were 0.505 in. diam.

	Tensile Strength	El. Limit.	Elong. in 2 in.	Red. o' Area
Bar from 1 in. sq. casting.....	79,600	31,800	49.2%	39.3%
Hot rolled 1-in. rod.....	88,150	58,000	36.0	67.9

The strength of monel metal wire, used for window screen cloth, is given as 90,000 lb. per sq. in., and its analysis 68% Ni, 28% Cu., 2.5% Fe, 1.5% Mn.

**Constantan** is an alloy containing about 60% copper and 40% nickel, which is much used for resistance wire in electrical instruments. Its electrical resistance is about twenty-eight to thirty times that of copper, and it possesses a very low temperature coefficient, — approximately

.00003. This same material is also much used to form one element of base-metal thermo-couples.

**Manganin**, Cu Mn Ni, high resistance alloy. See Electrical Resistance under Electrical Engineering.

### ALLOYS OF BISMUTH.

By adding a small amount of bismuth to lead the latter may be hardened and toughened. An alloy consisting of three parts of lead and two of bismuth has ten times the hardness and twenty times the tenacity of lead. The alloys of bismuth with both tin and lead are extremely fusible, and take fine impressions of casts and molds. An alloy of one part Bi, two parts Sn, and one part Pb is used by pewter-workers as a soft solder, and by soap-makers for molds. An alloy of five parts Bi, two parts Sn, and three parts Pb melts at 199° F., and is somewhat used for stereotyping, and for metallic writing-pencils. Thorpe gives the following proportions for the better-known fusible metals:

Name of Alloy.	Bis- muth.	Lead.	Tin.	Cad- mium.	Mer- cury.	Melting- point.
Newton's.....	50	31.25	18.75	.....	.....	202° F.
Rose's.....	50	28.10	24.10	.....	.....	203° "
D'Arcet's.....	50	25.00	25.00	.....	.....	201° "
D'Arcet's with mercury	50	25.00	25.00	.....	250.0	113° "
Wood's.....	50	25.00	12.50	12.50	.....	149° "
Lipowitz's.....	50	26.90	12.78	10.40	.....	149° "
Guthrie's "Eutectic".	50	20.55	21.10	14.03	.....	"Very low."

The action of heat upon some of these alloys is remarkable. Thus, Lipowitz's alloy, which solidifies at 149° F., contracts very rapidly at first, as it cools from this point. As the cooling goes on the contraction becomes slower and slower, until the temperature falls to 101.3° F. From this point the alloy *expands* as it cools, until the temperature falls to about 77° F., after which it again contracts, so that at 32° F. a bar of the alloy has the same length as at 115° F.

Alloys of bismuth have been used for making fusible plugs for boilers, but it is found that they are altered by the continued action of heat, so that one cannot rely upon them to melt at the proper temperature. Pure Banca tin is used by the U. S. Government for fusible plugs.

### FUSIBLE ALLOYS.

(From various sources. Many of the figures are probably very inaccurate.)

Sir Isaac Newton's, bismuth 5, lead 3, tin 2, melts at.....	212° F.
Rose's, bismuth 2, lead 1, tin 1, melts at.....	200 "
Wood's, cadmium 1, bismuth 4, lead 2, tin 1, melts at.....	165 "
Guthrie's, cadmium 13.29, bismuth 47.38, lead 19.36, tin 19.97, melts at.....	160 "
Lead 1, tin 1, bismuth 1, cadmium 1, melts at.....	155 "
Lead 3, tin 5, bismuth 8, melts at.....	208 "
Lead 1, tin 3, bismuth 5, melts at.....	212 "
Lead 1, tin 4, bismuth 5, melts at.....	240 "
Tin 1, bismuth 1, melts at.....	286 "
Lead 2, tin 3, melts at.....	334 to 367 "
Tin 2, bismuth 1, melts at.....	336 "
Lead 1, tin 2, melts at.....	340 to 360 "
Tin 8, bismuth 1, melts at.....	392 "
Lead 2, tin 1, melts at.....	440 to 475 "
Lead 1, tin 1, melts at.....	370 to 400 "
Lead 1, tin 3, melts at.....	356 to 383 "
Tin 3, bismuth 1, melts at.....	392 "
Lead 1, bismuth 1, melts at.....	257 "
Lead 1, tin 1, bismuth 4, melts at.....	201 "
Lead 5, tin 3, bismuth 8, melts at.....	202 "
Tin 3, bismuth 5, melts at.....	202 "

**BEARING-METAL ALLOYS.**

(C. B. Dudley, *Jour. F. I.*, Feb. and March, 1892.)

Alloys are used as bearings in place of wrought iron, cast iron, or steel, partly because wear and friction are believed to be more rapid when two metals of the same kind work together, partly because the soft metals are more easily worked and got into proper shape, and partly because it is desirable to use a soft metal which will take the wear rather than a hard metal, which will wear the journal more rapidly.

A good bearing-metal must have five characteristics: (1) It must be strong enough to carry the load without distortion. Pressures on car-journals are frequently as high as 350 to 400 lb. per square inch.

(2) A good bearing-metal should not heat readily. The old copper-tin bearing, made of seven parts copper to one part tin, is more apt to heat than some other alloys. In general, research seems to show that the harder the bearing-metal, the more likely it is to heat.

(3) Good bearing-metal should work well in the foundry. Oxidation while melting causes spongy castings. It can be prevented by a liberal use of powdered charcoal while melting. The addition of 1% to 2% of zinc or a small amount of phosphorus greatly aids in the production of sound castings. This is a principal element of value in phosphor-bronze.

(4) Good bearing-metals should show small friction. It is true that friction is almost wholly a question of the lubricant used; but the metal of the bearing has certainly some influence.

(5) Other things being equal, the best bearing-metal is that which wears slowest.

The principal constituents of bearing-metal alloys are copper, tin, lead, zinc, antimony, iron, and aluminum. The following table gives the constituents of most of the prominent bearing-metals as analyzed at the Pennsylvania Railroad laboratory at Altoona.

**Analyses of Bearing-metal Alloys.**

Metal.	Copper.	Tin.	Lead.	Zinc.	Anti- mony.	Iron.
Camelia metal.....	70.20	4.25	14.75	10.20	.....	0.55
Anti-friction metal.....	1.60	98.13	.....	.....	.....	trace
White metal.....	.....	.....	87.92	.....	12.08	.....
Car-brass lining.....	.....	trace	84.87	.....	15.10	.....
Salgee anti-friction.....	4.01	9.91	1.15	85.57	.....	.....
Graphite bearing-metal.....	.....	14.38	67.73	.....	16.73	? (1)
Antimonial lead.....	.....	.....	80.69	.....	18.83	.....
Carbon bronze.....	75.47	9.72	14.57	.....	.....	(2)
Cornish bronze.....	77.83	9.60	12.40	trace	.....	trace(3)
Delta metal.....	92.39	2.37	5.10	.....	.....	0.07
* Magnolia metal.....	trace	.....	83.55	trace	16.45	trace(4)
American anti-friction metal.....	.....	.....	78.44	0.98	19.60	0.65
Tobin bronze.....	59.00	2.16	0.31	38.40	.....	0.11
Graney bronze.....	75.80	9.20	15.06	.....	.....	.....
Damascus bronze.....	76.41	10.60	12.52	.....	.....	.....
Manganese bronze.....	90.52	9.58	.....	.....	.....	(5)
Ajax metal.....	81.24	10.98	7.27	.....	.....	(6)
Anti-friction metal.....	.....	.....	88.32	.....	11.93	.....
Harrington bronze.....	55.73	0.97	.....	42.67	.....	0.68
Car-box metal.....	.....	.....	84.33	trace	14.38	0.61
Hard lead.....	.....	.....	94.40	.....	6.03	.....
Phosphor-bronze.....	79.17	10.22	9.61	.....	.....	(7)
Ex. B. metal.....	76.80	8.00	15.00	.....	.....	(8)

Other constituents:

- (1) No graphite.
- (2) Possible trace of carbon.
- (3) Trace of phosphorus.
- (4) Possible trace of bismuth.
- (5) No manganese.
- (6) Phosphorus or arsenic, 0.37.
- (7) Phosphorus, 0.94.
- (8) Phosphorus, 0.20.

\* Dr. H. C. Torrey says this analysis is erroneous and that Magnolia metal always contains tin.



As an example of the influence of minute changes in an alloy, the Harrington bronze, which consists of a minute proportion of iron in a copper-zinc alloy, showed after rolling a tensile strength of 75,000 lb. and 20% elongation in 2 inches.

In experimenting on this subject on the Pennsylvania Railroad, a certain number of the bearings were made of a standard bearing-metal, and the same number were made of the metal to be tested. These bearings were placed on opposite ends of the same axle, one side of the car having the standard bearings, the other the experimental. Before going into service the bearings were carefully weighed, and after a sufficient time they were again weighed. The standard bearing-metal used is the "S bearing-metal" of the Phosphor-Bronze Smelting Co. It contains about 79.70% copper, 9.50% lead, 10% tin, and 0.80% phosphorus. A large number of experiments have shown that the loss of weight of a bearing of this metal is 1 lb. to each 18,000 to 25,000 miles traveled. Besides the measurement of wear, observations were made on the frequency of "hot boxes" with the different metals.

The results of the tests for wear, so far as given, are condensed into the following table:

Metal.	Composition.					Rate of Wear.
	Copper.	Tin.	Lead.	Phos.	Arsenic.	
Standard . . . . .	79.70	10.00	9.50	0.80	....	100
Copper-tin . . . . .	87.50	12.50	....	....	....	148
Same, second experiment . . . . .	....	....	....	....	....	153
Same, third experiment . . . . .	....	....	....	....	....	147
Arsenic-bronze . . . . .	89.20	10.00	....	....	0.80	142
Arsenic-bronze . . . . .	79.20	10.00	7.00	....	0.80	115
Arsenic-bronze . . . . .	79.70	10.00	9.50	....	0.80	101
"K" bronze . . . . .	77.00	10.50	12.50	....	....	92
Same, second experiment . . . . .	....	....	....	....	....	92.7
Alloy "B" . . . . .	77.00	8.00	15.00	....	....	86.5

The old copper-tin alloy of 7 to 1 has repeatedly proved its inferiority to the phosphor-bronze metal. Many more of the copper-tin bearings heated than of the phosphor-bronze. The showing of these tests was so satisfactory that phosphor-bronze was adopted as the standard bearing-metal of the Pennsylvania R.R., and was used for a long time.

The experiments, however, were continued. It was found that arsenic practically takes the place of phosphorus in a copper-tin alloy, and three tests were made with arsenic-bronzes as noted above. As the proportion to lead is increased to correspond with the standard, the durability increases as well. In view of these results the "K" bronze was tried, in which neither phosphorus nor arsenic were used, and in which the lead was increased above the proportion in the standard phosphor-bronze. The result was that the metal wore 7.30% slower than the phosphor-bronze. No trouble from heating was experienced with the "K" bronze more than with the standard. Dr. Dudley continues:

At about this time we began to find evidences that wear of bearing-metal alloys varied in accordance with the following law: "That alloy which has the greatest power of distortion without rupture (resilience), will best resist wear." It was now attempted to design an alloy in accordance with this law, taking first the proportions of copper and tin. 9 1/2 parts copper to 1 of tin was settled on by experiment as the standard, although some evidence since that time tends to show that 12 or possibly 15 parts copper to 1 of tin might have been better. The influence of lead on this copper-tin alloy seems to be much the same as a still further diminution of tin. However, the tendency of the metal to yield under pressure increases as the amount of tin is diminished, and the amount of the lead increased, so a limit is set to the use of lead. A certain amount of tin is also necessary to keep the lead alloyed with the copper.

Bearings were cast of the metal noted in the table as alloy "B," and it wore 13.5% slower than the standard phosphor-bronze. This metal is now the standard bearing-metal of the Pennsylvania Railroad, being slightly changed in composition to allow the use of phosphor-bronze scrap. The formula adopted is: Copper, 105 lbs.; phosphor-bronze, 60 lbs.; tin, 9 3/4 lbs.; lead, 25 1/4 lbs. By using ordinary care in the foundry, keeping the metal well covered with charcoal during the melt-



ing, no trouble is found in casting good bearings with this metal. The copper and the phosphor-bronze can be put in the pot before putting it in the melting-hole. The tin and lead should be added after the pot is taken from the fire.

It is not known whether the use of a little zinc, or possibly some other combination, might not give still better results. For the present, however, this alloy is considered to fulfill the various conditions required for good bearing-metal better than any other alloy. The phosphor-bronze had an ultimate tensile strength of 30,000 lb., with 6% elongation, whereas the alloy "B" had 24,000 lb. T. S. and 11% elongation.

*Bearing Metal Practice, 1907.* (G. H. Clamer, *Proc. A. S. T. M.*, vii, 302, discusses the history of bearing metal practice since the date of Dr. Dudley's paper quoted above. It was found that tin could be diminished and lead increased far beyond the figures formerly used, and a satisfactory bearing metal was made with 65% copper, 5% tin and 30% lead. This alloy is largely sold under the name of "plastic bronze." It has a compressive strength of about 15,000 lbs. per sq. in., and is found to operate without distortion in the bearings of the heaviest locomotives, not only for driving brasses, but also for rod brasses and bushings, and for bearings of cars of 100,000 lbs. capacity, the heaviest cars now in service. Specifications of different railroads cover bearing alloys with tin from 8 to 10% and lead from 10 to 15%. There is also used a vast quantity of bearings made from scrap. These contain copper, 65 to 75%, tin, 2 to 8%, lead, 10 to 18%, zinc, 5 to 20%, and they constitute from 50 to 75 per cent of the car bearings now in use.

**White Metal for Engine Bearings.** (Report of a British Naval Committee, *Eng'g*, July 18, 1902.)—For lining bearings, crankpin bushes, and other parts exclusive of cross-head bushes: Tin 12, copper 1, antimony 1. Melt 6 tin 1 copper, and 6 tin 1 antimony separately and mix the two together. For cross-head bushes a harder alloy, viz., 85% tin, 5% copper, 10% antimony, has given good results.

(For other bearing-metals, see "Alloys containing Antimony," below.)

**ALLOYS CONTAINING ANTIMONY.**

**VARIOUS ANALYSES OF BABBITT METAL AND OTHER ALLOYS CONTAINING ANTIMONY.**

	Tin.	Copper.	Antimony.	Zinc.	Lead.	Bismuth.
Babbitt metal	50	1	5 parts			
for light duty	=89.3	1.8	8.9 per ct.			
Harder Babbitt	96	4	8 parts			
for bearings*	=88.9	3.7	7.4 per ct.			
Britannia	85.7	1.0	10.1	2.9		
"	81.9	.....	16.2	1.9		
"	81.0	2	16	1		
"	70.5	4	25.5			
"	22	10	62	6		
" Babbitt "	45.5	1.5	13		40.0	
Plate pewter	89.3	1.8	7.1			1.8
White metal	85	5	10			Bearings on Ger. locomotives.

\* It is mixed as follows: Twelve parts of copper are first melted and then 36 parts of tin are added; 24 parts of antimony are put in, and then 36 parts of tin, the temperature being lowered as soon as the copper is melted in order not to oxidize the tin and antimony, the surface of the bath being protected from contact with the air. The alloy thus made is subsequently remelted in the proportion of 50 parts of alloy to 100 tin. (Joshua Rose.)

**White-metal Alloys.** -- The following alloys are used as lining metals by the Eastern Railroad of France (1890):

Number.	Lead.	Antimony.	Tin.	Copper.
1.....	65	25	0	10
2.....	0	11.12	83.33	5.55
3.....	70	20	10	0
4.....	80	8	12	0

No. 1 is used for lining cross-head slides, rod-brasses and axle-bearings; No. 2 for lining axle-bearings and connecting-rod brasses of heavy

engines; No. 3 for lining eccentric straps and for bronze slide-valves; and No. 4 for metallic rod-packing.

Some of the best-known white-metal alloys are the following (Circular of Hoveler & Dieckhaus, London, 1893):

	Tin.	Anti- mony.	Lead.	Copper.	Zinc.
1. Parsons'.....	86	1	2	2	27
2. Richards'.....	70	15	101/2	41/2	0
3. Babbitt's.....	55	18	231/2	31/2	0
4. Fenton's.....	16	0	0	5	79
5. French Navy.....	71/2	0	7	7	871/2
6. German Navy.....	85	71/2	0	71/2	0

"There are engineers who object to white metal containing lead or zinc. This is, however, a prejudice quite unfounded, inasmuch as lead and zinc often have properties of great use in white alloys.

It is a further fact that an "easy liquid" alloy must not contain more than 18% of antimony, which is an invaluable ingredient of white metal for improving its hardness; but in no case must it exceed that margin, as this would reduce the plasticity of the compound and make it brittle.

Hardest tin-lead alloy: 6 tin, 4 lead. Hardest of all tin alloys (?) : 74 tin, 18 antimony, 8 copper.

Alloy for thin open-work, ornamental castings: Lead 2, antimony 1. White metal for patterns: Lead 10, bismuth 6, antimony 2, common brass 8, tin 10.

Type-metal is made of various proportions of lead and antimony, from 17% to 20% antimony according to the hardness desired.

#### Babbitt Metals. (C. R. Tompkins, *Mechanical News*, Jan., 1891.)

The practice of lining journal-boxes with a metal that is sufficiently fusible to be melted in a common ladle is not always so much for the purpose of securing anti-friction properties as for the convenience and cheapness of forming a perfect bearing in line with the shaft without the necessity of boring them. Boxes that are bored, no matter how accurate, require great care in fitting and attaching them to the frame or other parts of a machine.

It is not good practice, however, to use the shaft for the purpose of casting the bearings, especially if the shaft be steel, for the reason that the hot metal is apt to spring it; the better plan is to use a mandrel of the same size or a trifle larger for this purpose. For slow-running journals, where the load is moderate, almost any metal that may be conveniently melted and will run free will answer the purpose. For wearing properties, with a moderate speed, there is probably nothing superior to pure zinc, but when not combined with some other metal it shrinks so much in cooling that it cannot be held firmly in the recess, and soon works loose; and it lacks those anti-friction properties which are necessary in order to stand high speed.

For line-shafting, and all work where the speed is not over 300 or 400 r. p. m., an alloy of 8 parts zinc and 2 parts block-tin will not only wear longer than any composition of this class, but will successfully resist a heavy load. The tin counteracts the shrinkage, so that the metal, if not overheated, will firmly adhere to the box until it is worn out. But this mixture does not possess sufficient anti-friction properties to warrant its use in fast-running journals.

Among all the soft metals in use there are none that possess greater anti-friction properties than pure lead; but lead alone is impracticable, for it is so soft that it cannot be retained in the recess. But when by any process lead can be sufficiently hardened to be retained in the boxes without materially injuring its anti-friction properties, there is no metal that will wear longer in light fast-running journals. With most of the best and most popular anti-friction metals in use and sold under the name of the Babbitt metal, the basis is lead.

Lead and antimony have the property of combining with each other in all proportions without impairing the anti-friction properties of either. The antimony hardens the lead, and when mixed in the proportion of 80

parts lead by weight with 20 parts antimony, no other known composition of metals possesses greater anti-friction or wearing properties, or will stand a higher speed without heat or abrasion. It runs free in its melted state, has no shrinkage, and is better adapted to light high-speed machinery than any other known metal. Care, however, should be manifested in using it, and it should never be heated beyond a temperature that will scorch a dry pine stick.

Many different compositions are sold under the name of Babbitt metal. Some are good, but more are worthless; while but very little genuine Babbitt metal is sold that is made strictly according to the original formula. Most of the metals sold under that name are the refuse of type-foundries and other smelting-works, melted and cast into fancy ingots with special brands, and sold under the name of Babbitt metal.

It is difficult at the present time to determine the exact formulas used by the original Babbitt, the inventor of the recessed box, as a number of different formulas are given for that composition. Tin, copper, and antimony were the ingredients, and from the best sources of information the original proportions were as follows:

50 parts tin.....	= 89.3%	Another writer gives:
2 parts copper.....	= 3.6%	83.3%
4 parts antimony.....	= 7.1%	8.3%
		8.3%

The copper was first melted, and the antimony added first and then about ten or fifteen pounds of tin, the whole kept at a dull-red heat and constantly stirred until the metals were thoroughly incorporated, after which the balance of the tin was added, and after being thoroughly stirred again it was then cast into ingots. When the copper is thoroughly melted, and before the antimony is added, a handful of powdered charcoal should be thrown into the crucible to form a flux, in order to exclude the air and prevent the antimony from vaporizing; otherwise much of it will escape in the form of a vapor and consequently be wasted. This metal, when carefully prepared, is probably one of the best metals in use for lining boxes that are subjected to a heavy weight and wear; but for light fast-running journals the copper renders it more susceptible to friction, and it is more liable to heat than the metal composed of lead and antimony in the proportions just given.

**SOLDERS.**

Common solders, equal parts tin and lead; fine solder, 2 tin to 1 lead; cheap solder, 2 lead, 1 tin.

Fusing-point of tin-lead alloys (many figures probably inaccurate).

Tin	1	to lead	25	.....	558° F.	Tin	1 1/2	to lead	1	.....	334° F.
"	"	"	10	.....	541	"	2	"	"	.....	340
"	1	"	5	.....	511	"	3	"	"	.....	356
"	1	"	3	.....	482	"	4	"	"	.....	365
"	1	"	2	.....	441	"	5	"	"	.....	378
"	1	"	1	.....	370	"	6	"	"	.....	381

The melting point of the tin-lead alloys decreases almost proportionately to the increase of tin, from 619°F, the melting point of pure lead, to 356°F when the alloy contains 68% of tin, and then increases to 448°F., the melting point of pure tin. Alloys on either side of the 68% mixture begin to soften materially at 356°F, because at that temperature the eutectic alloy melts and permits the whole alloy to soften. (Dr. J. A. Mathews.)

Common pewter contains 4 lead to 1 tin.

The relative hardness of the various tin and lead solders has been determined by Brinell's method. The results are as follows:

% Tin	0	10	20	30	40	50	60
Hardness	3.90	10.10	12.16	14.46	15.76	14.90	14.58
% Tin	66	67	68	70	80	90	100
Hardness	16.66	15.40	14.58	15.84	15.20	13.25	4.14



The hardest solder is the one composed of 2 parts of tin and 1 part of lead. It is the eutectic alloy, or the one with the lowest melting point of all the mixtures. — *Mechanical World.*

Gold solder: 14 parts gold, 6 silver, 4 copper. Gold solder for 14-carat gold: 25 parts gold, 25 silver, 12½ brass, 1 zinc.

Silver solder: Yellow brass 70 parts, zinc 7, tin 11½. Another: Silver 145 parts, brass (3 copper, 1 zinc) 73, zinc 4.

German-silver solder: Copper 38, zinc 54, nickel 8.

Novel's solders for aluminum:

Tin	100 parts,	lead 5;	melts at	536°	to	572° F.
"	100	" zinc 5;	"	536	to	612
"	1000	" copper 10 to 15;	"	662	to	842
"	1000	" nickel 10 to 15;	"	662	to	842

See also p. 383.

Novel's solder for aluminum bronze: Tin, 900 parts, copper 100, bismuth 2 to 3. It is claimed that this solder is also suitable for joining aluminum to copper, brass, zinc, iron or nickel.

## ROPES AND CABLES.

### STRENGTH OF ROPES.

(A. S. Newell & Co., Birkenhead. Klein's Translation of Weisbach, vol. iii, part 1, sec. 2.)

Hemp.		Iron.		Steel.		Tensile Strength, Gross tons.
Girth. Inches.	Weight per Fathom. Pounds.	Girth. Inches.	Weight per Fathom. Pounds.	Girth. Inches.	Weight per Fathom. Pounds.	
2¾	2	1	1			2
		1½	1½	1	1	3
3¾	4	1⅝	2			4
		1¾	2½	1½	1½	5
4½	5	1⅞	3			6
		2	3½	1⅝	2	7
5½	7	2⅛	4	1¾	2½	8
		2¼	4½			9
6	9	2⅜	5	1⅞	3	10
		2½	5½			11
6½	10	2⅝	6	2	3½	12
		2¾	6½	2⅛	4	13
7	12	2⅞	7	2¼	4½	14
		3	7½			15
7½	14	3⅛	8	2⅜	5	16
		3¼	8½			17
8	16	3⅜	9	2½	5½	18
		3½	10	2⅝	6	20
8½	18	3⅝	11	2¾	6½	22
		3¾	12			24
9½	22	3⅞	13	3¼	8	26
10	26	4	14			28
11	30	4¼	15	3⅜	9	30
		4⅜	16			32
		4½	18	3½	10	36
12	34	4⅝	20	3¾	12	40

**Length Sufficient to Cause the Maximum Working Stress.**  
(Weisbach.)

Hempen rope, dry and untarred.....	2855 feet.
Hempen rope, wet or tarred.....	1975 "
Wire rope.....	4590 "
Open-link chain.....	1360 "
Stud chain.....	1660 "

Sometimes, when the depths are very great, ropes are given approximately the form of a body of uniform strength, by making them of separate pieces, whose diameters diminish towards the lower end. It is evident that by this means the tensions in the fibres caused by the rope's own weight can be considerably diminished.

**Rope for Hoisting or Transmission. Manila Rope.** (C. W. Hunt Company, New York.) — Rope used for hoisting or for transmission of power is subjected to a very severe test. Ordinary rope chafes and grinds to powder in the center, while the exterior may look as though it was little worn.

In bending a rope over a sheave, the strands and the yarns of these strands slide a small distance upon each other, causing friction, and wear the rope internally.

The "Stevedore" rope used by the C. W. Hunt Company is made by lubricating the fibres with plumbago, mixed with sufficient tallow to hold it in position. This lubricates the yarns of the rope, and prevents internal chafing and wear. After running a short time the exterior of the rope gets compressed and coated with the lubricant.

In manufacturing rope, the fibres are first spun into a yarn, this yarn being twisted in a direction called "right hand." From 20 to 80 of these yarns, depending on the size of the rope, are then put together and twisted in the opposite direction, or "left hand," into a strand. Three of these strands, for a 3-strand, or four for a 4-strand rope, are then twisted together, the twist being again in the "right hand" direction. When the strand is twisted, it untwists each of the threads, and when the three strands are twisted together into rope, it untwists the strands, but again twists up the threads. It is this opposite twist that keeps the rope in its proper form. When a weight is hung on the end of a rope, the tendency is for the rope to untwist, and become longer. In untwisting the rope, it would twist the threads up, and the weight will revolve until the strain of the untwisting strands just equals the strain of the threads being twisted tighter. In making a rope it is impossible to make these strains exactly balance each other. It is this fact that makes it necessary to take out the "turns" in a new rope, that is, untwist it when it is put at work. The proper twist that should be put in the threads has been ascertained approximately by experience.

The amount of work that the rope will do varies greatly. It depends not only on the quality of the fibre and the method of laying up the rope, but also on the kind of weather when the rope is used, the blocks or sheaves over which it is run, and the strain in proportion to the strain put upon the rope. The principal wear comes in practice from defective or badly set sheaves, from excess of load and exposure to storms.

The loads put upon the rope should not exceed those given in the tables, for the most economical wear. The indications of excessive load will be the twist coming out of the rope, or one of the strands slipping out of its proper position. A certain amount of twist comes out in using it the first day or two, but after that the rope should remain substantially the same. If it does not, the load is too great for the durability of the rope. If the rope wears on the outside, and is good on the inside, it shows that it has been chafed in running over the pulleys or sheaves. If the blocks are very small, it will increase the sliding of the strands and threads, and result in a more rapid internal wear. Rope made for hoisting and for rope transmission is usually made with four strands, as experience has shown this to be the most serviceable.

The strength and weight of "Stevedore" rope is estimated as follows:

Breaking strength in pounds = 720 (circumference in inches)<sup>2</sup>;  
Weight in pounds per foot = 0.032 (circumference in inches)<sup>2</sup>.

**The Technical Words relating to Cordage** most frequently heard are:

**YARN.** — Fibres twisted together.

**THREAD.** — Two or more *small yarns* twisted together.

**STRING.** — The same as a thread but a little larger *yarns*.

**STRAND.** — Two or more *large yarns* twisted together.

**CORD.** — Several threads twisted together.

**ROPE.** — Several *strands* twisted together.

**HAWSER.** — A rope of three *strands*.

**SHROUD-LAID.** — A rope of four *strands*.

**CABLE.** — Three hawsers twisted together.

**YARNS** are laid up left-handed into *strands*.

**STRANDS** are laid up right-handed into rope.

**HAWSERS** are laid up left-handed into a cable.

#### A rope is:

**LAI**D by twisting strands together in making the rope.

**SPLI**CED by joining to another rope by interweaving the strands.

**WHI**PPED. — By winding a string around the end to prevent untwisting.

**SER**VED. — When covered by winding a yarn continuously and tightly around it.

**PAR**CELED. — By wrapping with canvas.

**SEI**ZED. — When two parts are bound together by a yarn, thread or string.

**PAY**ED. — When painted, tarred or greased to resist wet.

**HAU**L. — To pull on a rope.

**TAU**T. — Drawn tight or strained.

**Splicing of Rope.** — The splice in a transmission rope is not only the weakest part of the rope but is the first part to fail when the rope is worn out. If the rope is larger at the splice, the projecting part will wear on the pulleys and the rope fail from the cutting off of the strands. The following directions are given for splicing a 4-strand rope.

The engravings show each successive operation in splicing a 1 $\frac{3}{4}$ -inch manila rope. Each engraving was made from a full-size specimen.

Tie a piece of twine, 9 and 10, around the rope to be spliced, about 6 feet from each end. Then unlay the strands of each end back to the twine.

Butt the ropes together and twist each corresponding pair of strands loosely, to keep them from being tangled, as shown in Fig. 91.

The twine 10 is now cut, and the strand 8 unlaid and strand 7 carefully laid in its place for a distance of four and a half feet from the junction.

The strand 6 is next unlaid about one and a half feet and strand 5 laid in its place.

The ends of the cores are now cut off so they just meet.

Unlay strand 1 four and a half feet, laying strand 2 in its place.

Unlay strand 3 one and a half feet, laying in strand 4.

Cut all the strands off to a length of about twenty inches for convenience in manipulation.

The rope now assumes the form shown in Fig. 92 with the meeting points of the strands three feet apart.

Each pair of strands is successively subjected to the following operation:

From the point of meeting of the strands 8 and 7, unlay each one three turns; split both the strand 8 and the strand 7 in halves as far back as they are now unlaid and "whip" the end of each half strand with a small piece of twine.

The half of the strand 7 is now laid in three turns and the half of 8 also laid in three turns. The half strands now meet and are tied in a simple knot, 11, Fig. 93, making the rope at this point its original size.

The rope is now opened with a marlin spike and the half strand of 7 worked around the half strand of 8 by passing the end of the half strand 7 through the rope, as shown in the engraving, drawn taut, and again worked around this half strand until it reaches the half strand 13 that was not laid in. This half strand 13 is now split, and the half strand 7 drawn through the opening thus made, and then tucked under the two adjacent strands, as shown in Fig. 94. The other half of the strand 8 is now wound around the other half strand 7 in the same manner. After each pair of strands has been treated in this manner, the ends are cut off at 12, leaving them about four inches long. After a few days wear they will draw into the body of the rope or wear off, so that the locality of the splice can scarcely be detected.



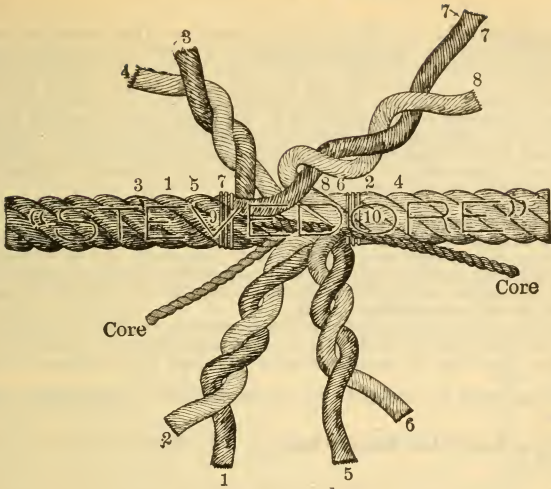

FIG. 91.

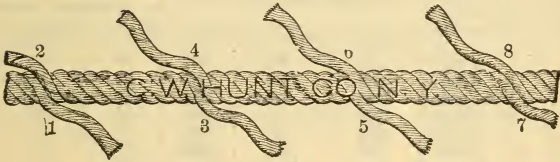

FIG. 92.

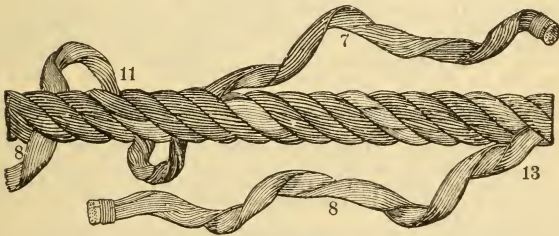

FIG. 93.

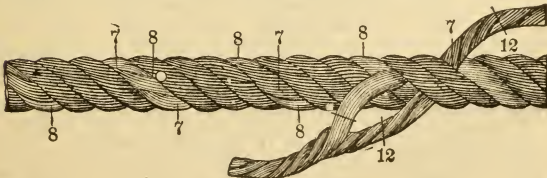

FIG. 94.

**Cargo Hoisting.** (C. W. Hunt Company.) — The amount of coal that can be hoisted with a rope varies greatly. Under the ordinary conditions of use a rope hoists from 5000 to 8000 tons. Where the circumstances are more favorable, the amounts run up frequently to 12,000 or 15,000 tons, occasionally to 20,000 and in one case 32,400 tons to a single fall.

When a hoisting rope is first put in use, it is likely from the strain put upon it to twist up when the block is loosened from the load. This occurs in the first day or two only. The rope should then be taken down and the "turns" taken out of the rope. When put up again the rope should give no further trouble until worn out.

It is necessary that the rope should be much larger than is needed to bear the strain from the load.

Practical experience for many years has substantially settled the most economical size of rope to be used which is given in the table below.

Hoisting ropes are not spliced, as it is difficult to make a splice that will not pull out while running over the sheaves, and the increased wear to be obtained in this way is very small.

Coal is usually hoisted with what is commonly called a "double whip;" that is, with a running block that is attached to the tub which reduces the strain on the rope to approximately one-half the weight of the load hoisted.

Hoisting rope is ordered by circumference, transmission rope by diameter.

**Working Loads for Manila Rope** (C. W. Hunt, *Trans. A. S. M. E.*, xxiii, 125.)

Diameter of Rope, Inches.	Ultimate Strength, Pounds.	Working Load in Pounds.			Minimum Diameter of Sheaves in Inches.		
		Rapid.	Medium.	Slow.	Rapid.	Medium.	Slow.
1	7,100	200	400	1000	40	12	8
1 1/8	9,000	250	500	1250	45	13	9
1 1/4	11,000	300	600	1500	50	14	10
1 3/8	13,400	380	750	1900	55	15	11
1 1/2	15,800	450	900	2200	60	16	12
1 5/8	18,800	530	1100	2600	65	17	13
1 3/4	21,800	620	1250	3000	70	18	14

In this table the work required of the rope is, for convenience, divided into three classes — "rapid," "medium," and "slow," these terms being used in the following sense: "Slow" — Derrick, crane and quarry work; speed from 50 to 100 feet per minute. "Medium" — Wharf and cargo, hoisting 150 to 300 feet per minute. "Rapid" — 400 to 800 feet per minute.

The ultimate strength given in the table is materially affected by the age and condition of a rope in active service, and also it is said to be weaker when it is wet. Trautwine states that a few months of exposed work weakens rope 20 to 50 per cent. The ultimate strength of a new rope given in the table is the result of tests of full sized specimens of manila rope, purchased in the open market, and made by three independent rope walks.

The proper diameter of pulley-block sheaves for different classes of work given in the table is a compromise of the various factors affecting the case. An increase in the diameter of sheave will materially increase the life of a rope. The advantage, however, is gained by increased difficulty of installation, a clumsiness in handling, and an increase in first cost. The best size is one that considers the advantages and the drawbacks as they are found in practical use, and makes a fair balance between the conflicting elements of the problem.

Records covering many years have been kept by various coal dealers, of the diameter and cost of their rope per ton of coal hoisted from vessels, using sheaves of from 12 to 16 inches in diameter. These records show conclusively that, in hoisting a bucket that produces 900 pounds stress upon the rope, a 1 1/4-inch diameter rope is too small and a 1 3/4-inch rope is too large for economy. The Pennsylvania Railroad Company uses 1 1/2 inch rope, running over 14-inch diameter sheaves for hoisting

freight on lighters in New York harbor, and handles on a single part of the rope loads up to 3,000 pounds as a maximum. Greater weights are handled on a 6-part tackle.

**Life of Hoisting and Transmission Rope.** A rope 1 1/2-in. diam. usually hoists from a vessel from 7000 to 10,000 tons of coal, running with a working stress of 850 to 950 lbs. over three sheaves, one 12 in., and two 16-in. diam. In hoisting 10,000 tons it makes 20,000 trips, bending in that time from a straight line to the curve of the sheave 120,000 times, when it is worn out. A 1000 ft. transmission in a tin-plate mill, with 1 1/2 in. rope, sheaves 5 ft., 17 ft., and 36 ft. apart, center to center, runs 5000 ft. per minute making 13,900 bends per hour, or more bends in 9 hours than the hoisting rope made in its entire life, yet the life of a transmission rope is measured in years, not hours. This enormous difference in the life of ropes of the same size and quality is wholly gained by reducing the stresses on the rope and increasing the diameter of the sheaves.

**Efficiency of Knots** as a percentage of the full strength of the rope and the factor of safety when used with the stresses given in the 5th column of the table of working loads.

Kind of Knot.	Effy.	Fact. S
Eye splice over an iron thimble.....	90	6.3
Short splice in the rope.....	80	5.6
Timber hitch, round turn, half-hitch.....	65	4.5
Bowline slip knot, clove hitch.....	60	4.2
Square knot, weaver's knot sheet bend.....	50	3.5
Flemish loop, overhand knot.....	45	3.1
Full strength of dry rope, average of four tests.....	100	7.0

**Efficiency of Rope Tackles.** Robert Grimshaw in 1893 tested a 3 3/4-in., 3-strand ordinary dry manila rope on a "cat and fish" tackle with a 6-fold purchase. The sheaves were 8-in. diam., the three upper ones having roller bearings and the three lower ones solid bushings. The results were as below:

Net load on tackle, weight raised, lbs.....	600	800	1000	1200
Theoretical force required to raise the weight	100	1333.3	166.7	200
Actual force required.....	158	198	243	288
Percentage above the theoretical.....	58	48	45.8	44

**Weight and Strength of Manila Rope.** Spencer Miller (*Eng'g News*, Dec. 6, 1890) gives a table of breaking strength of manila rope, which he considers more reliable than the strength computed by Mr. Hunt's formula: Breaking strength = 720 × (circumference in inches).<sup>2</sup> Mr. Miller's formula is: Breaking weight lbs. = circumference<sup>2</sup> × a coefficient which varies from 900 for 1/2" to 700 for 2" diameter rope, as below:

Circumference ..	1 1/2	2	2 1/2	2 3/4	3	3 1/2	3 3/4	4 1/4	4 1/2	5	5 1/2	6
Coefficient.....	900	845	820	790	780	765	760	745	735	725	712	700

**Knots.** The principle of a knot is that no two parts, which would move in the same direction if the rope were to slip, should lay along side of and touching each other. (See illustrations on the next page.)

The bowline is one of the most useful knots, it will not slip, and after being strained is easily untied. Commence by making a bight in the rope, then put the end through the bight and under the standing part as shown in *G*, then pass the end again through the bight, and haul tight.

The square or reef knot must not be mistaken for the "granny" knot that slips under a strain. Knots *H*, *K* and *M* are easily untied after being under strain. The knot *M* is useful when the rope passes through an eye and is held by the knot, as it will not slip and is easily untied after being strained.

The timber hitch *S* looks as though it would give way, but it will not; the greater the strain the tighter it will hold. The wall knot looks complicated, but is easily made by proceeding as follows: Form a bight with strand 1 and pass the strand 2 around the end of it, and the strand 3 round the end of 2 and then through the bight of 1 as shown in the cut *Z*. Haul the ends taut when the appearance is as shown in *AA*. The end of the strand 1 is now laid over the center of the knot, strand 2 laid over 1 and 3 over 2, when the end of 3 is passed through the bight of 1 as shown in *BB*. Haul all the strands taut as shown in *CC*.



**Varieties of Knots.** — A great number of knots have been devised of which a few only are illustrated, but those selected are the most frequently used. In the cut, Fig. 95, they are shown open, or before being drawn taut, in order to show the position of the parts. The names usually given to them are:

- |   |   |
|---|---|
| <ul style="list-style-type: none"> <li>A. Blight of a rope.</li> <li>B. Simple or Overhand knot.</li> <li>C. Figure 8 knot.</li> <li>D. Double knot.</li> <li>E. Boat knot.</li> <li>F. Bowline, first step.</li> <li>G. Bowline, second step.</li> <li>H. Bowline completed.</li> <li>I. Square or reef knot.</li> <li>J. Sheet bend or weaver's knot.</li> <li>K. Sheet bend with a toggle.</li> <li>L. Carrick bend.</li> <li>M. Stevedore knot completed.</li> <li>N. Stevedore knot commenced.</li> <li>O. Slip knot.</li> </ul> | <ul style="list-style-type: none"> <li>P. Flemish loop.</li> <li>Q. Chain knot with toggle.</li> <li>R. Half-hitch.</li> <li>S. Timber-hitch.</li> <li>T. Clove-hitch.</li> <li>U. Rolling-hitch.</li> <li>V. Timber-hitch and half-hitch.</li> <li>W. Blackwall-hitch.</li> <li>X. Fisherman's bend.</li> <li>Y. Round turn and half-hitch</li> <li>Z. Wall knot commenced.</li> <li>AA. Wall knot completed.</li> <li>BB. Wall knot crown commenced.</li> <li>CC. Wall knot crown completed.</li> </ul> |
|---|---|

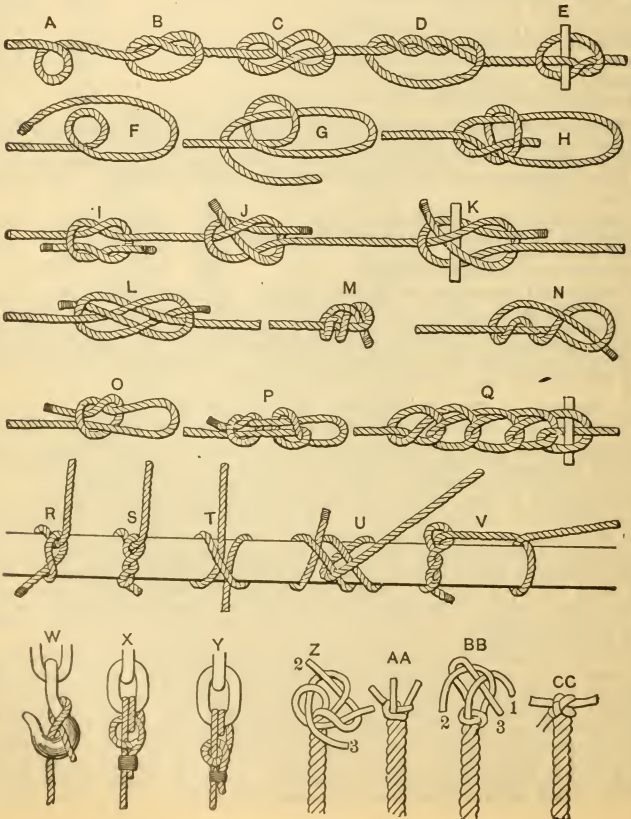

FIG. 95. — KNOTS.

SPRINGS.

**Definitions.** — A spiral spring is one which is wound around a fixed point or center, and continually receding from it, like a watch spring. A helical spring is one which is wound around an arbor, and at the same time advancing like the thread of a screw. An elliptical or laminated spring is made of flat bars, plates, or "leaves," of regularly varying lengths, superposed one upon the other.

**Laminated Steel Springs.** — Clark (Rules, Tables and Data) gives the following from his work on *Railway Machinery*, 1855:

$$\Delta = \frac{1.66 L^3}{bt^3n}; \quad s = \frac{bt^2n}{11.3 L}; \quad n = \frac{1.66 L^3}{\Delta bt^3};$$

- $\Delta$  = elasticity, or deflection, in sixteenths of an inch per ton of load;
- $s$  = working strength, or load, in tons (2240 lbs.);
- $L$  = span, when loaded in inches;
- $b$  = breadth of plates, in inches, taken as uniform;
- $t$  = thickness of plates, in sixteenths of an inch;
- $n$  = number of plates.

**NOTE.** — 1. The span and the elasticity are those due to the spring when weighted.

2. When extra thick back and short plates are used, they must be replaced by an equivalent number of plates of the ruling thickness, prior to the employment of the first two formulæ. This is found by multiplying the number of extra thick plates by the cube of their thickness, and dividing by the cube of the ruling thickness. Conversely, the number of plates of the ruling thickness given by the third formula, required to be deducted and replaced by a given number of extra thick plates, are found by the same calculation.

3. It is assumed that the plates are similarly and regularly formed, and that they are of uniform breadth, and but slightly taper at the ends. Reuleaux's Constructor gives for semi-elliptic springs:

$$P = \frac{Snbh^2}{6l} \quad \text{and} \quad f = \frac{6Pl^3}{Enbh^3};$$

- $S$  = max. direct fiber-strain in plate;
- $n$  = number of plates in spring;
- $l$  = one-half length of spring;
- $P$  = load on one end of spring;
- $b$  = width of plates;
- $h$  = thickness of plates;
- $f$  = deflection of end of spring;
- $E$  = modulus of direct elasticity

The above formula for deflection can be relied upon where all the plates of the spring are regularly shortened; but in semi-elliptic springs, as used, there are generally several plates extending the full length of the spring, and the proportion of these long plates to the whole number is usually about one-fourth. In such cases  $f = \frac{5.5 Pl^3}{Enbh^3}$ . (G. R. Henderson, *Trans. A. S. M. E.*, vol. xvi.)

In order to compare the formulæ of Reuleaux and Clark we may make the following substitutions in the latter:  $s$  in tons =  $P$  in lbs.  $\div$  1120;  $\Delta s = 16 f$ ;  $L = 2 l$ ;  $t = 16 h$ ; then

$$\Delta s = 16 f = \frac{1.66 \times 8 l^3 \times P}{4096 \times 1120 \times nbh^3}, \quad \text{whence} \quad f = \frac{Pl^3}{5,527,133nbh^3}$$

which corresponds with Reuleaux's formula for deflection if in the latter we take  $E = 33,162,800$ .

$$\text{Also} \quad s = \frac{P}{1120} = \frac{256 nbh^2}{11.3 \times 2l}, \quad \text{whence} \quad P = \frac{12,687 nbh^2}{l}$$

which corresponds with Reuleaux's formula for working load when  $S$  in the latter is taken at 76,120.

The value of  $E$  is usually taken at 30,000,000 and  $S$  at 80,000, in which case Reuleaux's formulæ become

$$\left[ P = \frac{13,333 nbh^2}{l} \quad \text{and} \quad f = \frac{Pl^3}{5,000,000nbh^3} \right]$$

G. R. Henderson, in *Trans. A. S. M. E.*, vol. xvii, gives a series of tables for use in designing both elliptical and helical springs.

### Helical Steel Springs.

NOTATION. Let  $d$  = diam. of wire or rod of which the spring is made.  
 $D$  = outside diameter of coil, inches.  
 $R$  = mean radius of coil, =  $1/2 (D - d)$ .  
 $n$  = number of coils.  
 $P$  = load applied to the spring, lbs.  
 $G$  = modulus of torsional elasticity.  
 $S$  = stress on extreme fiber caused by load  $P$ .  
 $F$  = extension or compression of one coil, in., for load  $P$ .  
 $F_n$  = total extension or compression, for load  $P$ .  
 $W$  = safe carrying capacity of spring, lbs.

$$F = \frac{64 PR^3}{Gd^4}; \quad F_n = \frac{64 PR^3 n}{Gd^4}; \quad W = \frac{0.1963 Sd^3}{R} = \frac{\pi Sd^3}{16 R}$$

Values of  $G$  according to different authorities range from 10,000,000 to 14,000,000.

The safe working value commonly taken for  $S$  = 60,000 lbs. per sq. in. Taking  $G$  at 12,000,000 and  $S$  at 60,000 the above formulæ become

$$F = \frac{PR^3}{187,500 d^4}, \quad W = 11,781 \frac{d^3}{R}. \quad \text{If } P = W, \text{ then } F = 0.06285 \frac{R^2}{d}$$

For square steel the values found for  $F$  and  $W$  are to be multiplied by 0.59 and 1.2 respectively,  $d$  being the side of the square.

The stress in a helical spring is almost wholly one of torsion. For method of deriving the formulæ for springs from torsional formulæ see paper by J. W. Cloud, *Trans. A. S. M. E.*, vol. 173. Mr. Cloud takes  $S$  = 80,000 and  $G$  = 12,600,000.

Taking from the Pennsylvania Railroad Specifications (1891) the capacity when closed,  $W_1$ , of the following springs, and the total compression when closed  $H - h$ , in which  $H$  = height when free and  $h$  when closed, and assuming  $n = h \div d$ , we have the following comparison of the specified values of capacity and compression with those obtained from the formulæ.

No.	$d$ , in.	$D$	$D - d$	$W_1$	$W$	$H$	$h$	$H - h$	$F_n$	$n$
T.	1/4	11/2	11/4	400	295	9	6	3	3.20	24
S.	1/2	3	2 1/2	1900	1178	8	5	3	3.16	10
K.	3/4	5 3/4	5	2100	1988	7	4 1/4	2 3/4	3.15	5 2/3
D.	1	5	4	8100	5890	10 1/2	8	2 1/2	2.76	8
I.	1 1/4	8	6 3/4	10000	6788	9	5 3/4	3 1/4	3.86	4 3/5
C.	1 1/8	4 7/8	3 3/4	16000	8946	4 3/8	3 3/8	1	1.05	3

The value of  $F_n$  in the table is calculated from the formula with  $P = W_1$ . Wilson Hartnell (*Proc. Inst. M. E.*, 1882, p. 426), says: "The size of a spiral spring may be calculated from the formula on page 304 of 'Rankine's Useful Rules and Tables;' but the experience with Salter's springs has shown that the safe limit of stress is more than twice as great as there given, namely 60,000 to 70,000 lbs. per square inch of section with 3/8-inch wire, and about 50,000 with 1/2-inch wire. Hence the work that can be done by springs of wire is four or five times as great as Rankine allows,



For  $\frac{3}{8}$ -inch wire and under,

$$\text{Maximum load in lbs.} = \frac{12,000 \times (\text{diam. of wire})^3}{\text{Mean radius of springs}};$$

$$\text{Weight in lbs. to deflect spring 1 in.} = \frac{180,000 \times (\text{diam.})^4}{\text{Number of coils} \times (\text{rad.})^3}.$$

The work in foot-pounds that can be stored up in a spiral spring would lift it above 50 ft.

In a few rough experiments made with Salter's springs the coefficient of rigidity was noticed to be 12,600,000 to 13,700,000 with  $\frac{1}{4}$ -inch wire; 11,000,000 for  $\frac{11}{32}$  inch; and 10,600,000 to 10,900,000 for  $\frac{3}{8}$ -inch wire.

**Helical Springs.** — J. Begtrup, in the *American Machinist* of Aug. 18, 1892, gives formulas for the deflection and carrying capacity of helical springs of round and square steel, as follow:

$$W = 0.3927 \frac{Sd^3}{D-d}, \quad F = 8 \frac{P(D-d)^3}{Ed^4}, \quad \text{for round steel.}$$

$$W = 0.471 \frac{Sd^3}{D-d}, \quad F = 4.712 \frac{P(D-d)^3}{Ed^4}, \quad \text{for square steel.}$$

- $W$  = carrying capacity in pounds,
- $S$  = greatest shearing stress per square inch of material,
- $d$  = diameter of steel,
- $D$  = outside diameter of coil,
- $F$  = deflection of one coil,
- $E$  = torsional modulus of elasticity,
- $P$  = load in pounds.

From these formulas the following table has been calculated by Mr. Begtrup. A spring being made of an elastic material, and of such shape as to allow a great amount of deflection, will not be affected by sudden shocks or blows to the same extent as a rigid body, and a factor of safety very much less than for rigid constructions may be used.

### HOW TO USE THE TABLE.

When designing a spring for continuous work, as a car spring, use a greater factor of safety than in the table; for intermittent working, as in a steam-engine governor or safety valve, use figures given in table; for square steel multiply line  $W$  by 1.2 and line  $F$  by 0.59.

*Example 1.* — How much will a spring of  $\frac{3}{8}$ " round steel and 3" outside diameter carry with safety? In the line headed  $D$  we find 3, and right underneath 473, which is the weight it will carry with safety. How many coils must this spring have so as to deflect 3" with a load of 400 pounds? Assuming a modulus of elasticity of 12 millions we find in the line headed  $F$  the figure 0.0610; this is deflection of one coil for a load of 100 pounds; therefore  $0.061 \times 4 = 0.244$ " is deflection of one coil for 400 pounds load, and  $3 \div 0.244 = 12\frac{1}{2}$  is the number of coils wanted. This spring will therefore be  $4\frac{3}{4}$ " long when closed, counting working coils only, and stretch to  $7\frac{3}{4}$ ".

*Example 2.* — A spring  $3\frac{1}{4}$ " outside diameter of  $\frac{7}{16}$ " steel is wound close; how much can it be extended without exceeding the limit of safety? We find maximum safe load for this spring to be 702 pounds, and deflection of one coil for 100 pounds load 0.0405 inches; therefore  $7.02 \times 0.0405 = 0.284$ " is the greatest admissible opening between coils. We may thus, without knowing the load, ascertain whether a spring is overloaded or not.

### Carrying Capacity and Deflection of Helical Springs of Round Steel.

$d$  = diameter of steel.  $D$  = outside diameter of coil.  $W$  = safe working load in pounds — tensile stress not exceeding 60,000 pounds per square inch.  $F$  = deflection by a load of 100 pounds of one coil, with a modulus of elasticity of 12 millions. The ultimate carrying capacity will be about twice the safe load. (The original table gives three values

of  $F$ , corresponding respectively to a modulus of elasticity of 10, 12 and 14 millions. To find values of  $F$  for 10 million modulus increase the figures here given by one-fifth; for 14 million subtract one-seventh.)

.065	D	0.25	0.50	0.75	1.00	1.25	1.50	1.75	2.00			
	W	35	15	9	7	5	4.5	3.8	3.3			
	F	0.0236	0.3075	1.228	3.053	6.214	11.04	17.87	27.06			
.120	D	0.50	0.75	1.00	1.25	1.50	1.75	2.00	2.25	2.50		
	W	107	65	46	36	29	25	22	19	17		
	F	0.0176	0.0804	0.2191	0.4639	0.8448	1.392	2.136	3.107	4.334		
.180	D	0.75	1.00	1.25	1.50	1.75	2.00	2.25	2.50	2.75	3.00	
	W	241	167	128	104	88	75	66	59	53	49	
	F	0.0118	0.0350	0.0778	0.1460	0.2457	0.3828	0.5632	0.7928	1.077	1.423	
1/4	D	1.25	1.50	1.75	2.00	2.25	2.50	2.75	3.00	3.25	3.50	
	W	368	294	245	210	184	164	147	134	123	113	
	F	0.0171	0.0333	0.0576	0.0914	0.1365	0.1944	0.2665	0.3548	0.4607	0.5859	
5/16	D	1.50	1.75	2.00	2.25	2.50	2.75	3.00	3.25	3.50	3.75	4.00
	W	605	500	426	371	329	295	267	245	226	209	195
	F	0.0117	0.0207	0.0336	0.0508	0.0732	0.1012	0.1357	0.1771	0.2263	0.2839	0.3505
3/8	D	2.00	2.25	2.50	2.75	3.00	3.25	3.50	3.75	4.00	4.25	4.50
	W	765	663	589	523	473	433	398	368	343	321	301
	F	0.0145	0.0222	0.0323	0.0452	0.0610	0.0801	0.1029	0.1297	0.1606	0.1963	0.2367
7/16	D	2.00	2.25	2.50	2.75	3.00	3.25	3.50	3.75	4.00	4.50	5.00
	W	1263	1089	957	853	770	702	644	596	544	486	432
	F	0.0069	0.0108	0.0160	0.0225	0.0306	0.0405	0.0529	0.0661	0.0823	0.1220	0.1728
1/2	D	2.00	2.25	2.50	2.75	3.00	3.25	3.50	3.75	4.00	4.50	5.00
	W	1963	1683	1472	1309	1178	1071	982	906	841	736	654
	F	0.0036	0.0057	0.0085	0.0121	0.0167	0.0222	0.0288	0.0366	0.0457	0.0683	0.0972
9/16	D	2.50	2.75	3.00	3.25	3.50	3.75	4.00	4.25	4.50	5.00	5.50
	W	2163	1916	1720	1560	1427	1315	1220	1137	1065	945	849
	F	0.0048	0.0070	0.0096	0.0129	0.0169	0.0216	0.0271	0.0334	0.0406	0.0582	0.0801
5/8	D	2.50	2.75	3.00	3.25	3.50	3.75	4.00	4.25	4.50	5.00	5.50
	W	3068	2707	2422	2191	2001	1841	1704	1587	1484	1315	1180
	F	0.0029	0.0042	0.0058	0.0079	0.0104	0.0133	0.0168	0.0208	0.0254	0.0366	0.0506
11/16	D	3.00	3.25	3.50	3.75	4.00	4.25	4.50	4.75	5.00	5.50	6.00
	W	3311	2988	2723	2500	2311	2151	2009	1885	1776	1591	1441
	F	0.0037	0.0050	0.0066	0.0086	0.0108	0.0135	0.0165	0.0200	0.0239	0.0333	0.0447
3/4	D	3.00	3.25	3.50	3.75	4.00	4.25	4.50	4.75	5.00	5.50	6.003
	W	4418	3976	3615	3313	3058	2840	2651	2485	2339	2093	1893
	F	0.0024	0.0033	0.0044	0.0057	0.0072	0.0090	0.0111	0.0135	0.0162	0.0226	0.0005
7/8	D	3.50	3.75	4.00	4.25	4.50	4.75	5.00	5.25	5.50	6.00	6.50
	W	6013	5490	5051	4676	4354	4073	3826	3607	3413	3080	2806
	F	0.0018	0.0024	0.0030	0.0038	0.0047	0.0058	0.0070	0.0083	0.0098	0.0134	0.0177
1	D	3.50	3.75	4.00	4.25	4.50	4.75	5.00	5.25	5.50	6.00	6.50
	W	9425	8568	7854	7250	6732	6283	5890	5544	5236	4712	4284
	F	0.0010	0.0014	0.0018	0.0023	0.0028	0.0035	0.0043	0.0051	0.0061	0.0083	0.0111

F. D. Howe, *Am. Mach.*, Dec. 20, 1906, using Begtrup's formulæ, computes a table for springs made from wire of Roebing's or Washburn and Moen gauges, Nos. 28 to 000. It is here given somewhat abridged, values of  $F$  corresponding to a torsional modulus of elasticity of 12,000,000 only being used.

No. 28 0.016"	D	0.20	0.25	0.3125	0.375	0.4375	0.500	0.5625	0.625	0.75	0.875
	W	0.524	0.41	0.31	0.27	0.23	0.20	0.175	0.16	0.13	0.11
	F	6.32	13.02	30.2	47.0	76.0	115	166	230	402	695
No. 24 0.0225"	D	0.25	0.3125	0.375	0.4375	0.500	0.5625	0.625	0.75	0.875	1.00
	W	1.18	0.92	0.76	0.45	0.56	0.50	0.45	0.37	0.31	0.28
	F	2.78	6.31	11.35	18.57	28.2	40.8	56.9	97.5	166	242
No. 22 0.028"	D	0.25	0.3125	0.375	0.4375	0.50	0.5625	0.625	0.75	0.875	1.00
	W	2.35	1.84	1.49	1.26	1.095	0.96	0.865	0.715	0.61	0.53
	F	1.19	2.50	4.53	7.42	11.40	16.5	23.1	40.8	66.0	99.5
No. 20 0.035"	D	0.25	0.3125	0.375	0.4375	0.50	0.5625	0.625	0.75	0.875	1.00
	W	4.7	3.64	2.97	2.5	2.18	1.92	1.72	1.42	1.20	1.05
	F	0.451	0.952	1.75	2.90	4.47	6.51	9.14	16.3	26.4	40.0
No. 18 0.047"	D	0.25	0.3125	0.375	0.4375	0.50	0.625	0.75	0.875	1.00	1.125
	W	12.05	9.2	7.45	6.57	5.40	4.23	3.48	2.95	2.85	2.27
	F	0.1158	0.294	0.488	0.824	1.320	1.870	3.96	7.85	12.60	17.5
No. 14 0.08"	D	0.375	0.5	0.625	0.75	0.875	1.00	1.125	1.25	1.50	1.75
	W	41	28.8	22.2	18.1	15.2	13.15	11.6	10.35	8.52	7.25
	F	0.0418	0.121	0.342	0.572	0.82	1.27	1.86	2.60	5.48	7.57
No. 12 0.105"	D	0.625	0.75	0.875	1.00	1.25	1.50	1.75	2.00	2.25	2.50
	W	52.5	42.25	35.4	30.4	23.8	19.5	16.6	14.4	12.7	11.4
	F	0.069	0.1480	0.262	0.395	0.830	1.49	2.45	3.74	5.45	7.34
No. 10 0.135"	D	0.875	1.00	1.25	1.50	1.75	2.00	2.25	2.50	2.75	3.00
	W	77	67	52	42.5	36	31	27	24	22	20
	F	0.081	0.135	0.276	0.512	0.846	1.295	1.910	2.660	3.58	4.75
No. 8 0.162"	D	1.00	1.25	1.50	1.75	2.00	2.25	2.50	2.75	3.00	3.25
	W	120	98.5	76	64	55.5	48.8	43.5	39	36	33
	F	0.0570	0.124	0.199	0.554	0.597	0.880	1.26	1.68	2.20	2.85
No. 7 0.177"	D	1.00	1.25	1.50	1.75	2.00	2.25	2.50	2.75	3.00	3.25
	W	159	122	99	83.5	72	63	56.4	51	46.5	42.5
	F	0.0382	0.0828	0.156	0.265	0.416	0.603	0.830	1.15	1.54	1.96
No. 6 0.192"	D	1.25	1.50	1.75	2.00	2.25	2.50	2.75	3.00	3.25	3.50
	W	158	128	107	92.5	81	72	65	59.5	55.5	50
	F	0.0572	0.108	0.185	0.284	0.420	0.590	0.802	1.07	1.38	1.74
No. 5 0.205"	D	1.50	1.75	2.00	2.25	2.50	2.75	3.00	3.25	3.50	4.00
	W	155	131	113	99	88.5	80	70	67	61.5	53.5
	F	0.0820	0.139	0.218	0.321	0.412	0.6175	0.82	1.60	1.34	2.22
No. 4 0.225"	D	1.50	1.75	2.00	2.25	2.50	2.75	3.00	3.25	3.50	4.00
	W	210	175	150	132	118	106	97	89	82	71
	F	0.0536	0.093	0.147	0.220	0.303	0.412	0.652	0.715	0.91	1.30
No. 2 0.263"	D	1.50	1.75	2.00	2.25	2.50	2.75	3.00	3.25	3.50	4.00
	W	345	290	250	215	192	175	156	146	134	115
	F	0.0264	0.0458	0.0730	0.109	0.154	0.214	0.274	0.371	0.469	0.720
No. 1 0.283"	D	1.75	2.00	2.25	2.50	2.75	3.00	3.25	3.50	4.00	4.50
	W	360	310	270	240	215	195	180	165	145	127
	F	0.0328	0.0550	0.0778	0.112	0.155	0.208	0.270	0.344	0.530	0.775
No. 0 0.307"	D	1.75	2.00	2.25	2.50	2.75	3.00	3.25	3.50	4.00	4.50
	W	470	400	350	310	280	250	230	212	185	162
	F	0.0308	0.0380	0.0548	0.0788	0.109	0.149	0.199	0.244	0.327	0.550
No. 00 0.331"	D	2.00	2.25	2.50	2.75	3.00	3.25	3.50	4.00	4.50	5.00
	W	510	445	390	350	320	290	270	230	205	183
	F	0.0289	0.0388	0.0564	0.0780	0.105	0.137	0.176	0.273	0.414	0.562

To find deflection of one coil by one pound, divide the values of F by 100.



ELLIPTICAL SPRINGS, SIZES, AND PROOF TESTS.

Pennsylvania Railroad Specifications, 1896.

Class.	Length between Centers, Ins.	Width over all, Inches.	Plates, No. Size, In	Tests.					
				Ins. high. (a)	(b)	lbs.	Ins. (a)	lbs.	a. p. t. (a) ins.
E 1, Triple.....	40	113/4	5 3 × 11/32	33/4	93/8	4,800	3	5,500	2
E 2, Quadruple..	40	151/2	5 3 × 3/8	33/4	93/4	6,650	3	8,000	2
E 3, Triple.....	36	113/4	6 3 × 11/32	4	95/8	6,000	3	8,000	.....
E 4, Single †.....	40	.....	8 3 × 11/32	5*	.....	free	3	2,350	.....
E 5, " †.....	40	.....	7 3 × 3/8	15/16*	.....	3,000	0	4,970	.....
E 6, " †.....	42	.....	8 31/2 × 3/8	11/8*	.....	4,375	0	6,350	.....
E 7, Triple.....	36	113/4	8 3 × 11/32	21/2	91/2	11,800	.....	.....	.....
E 8, Double.....	32	71/2	6 3 × 3/8	3	9	8,000	.....	.....	.....
E 9, ".....	36	91/2	5 4 × 11/32	31/2	87/16	5,400	3	6,000	.....
E 10, Quadruple..	40	151/2	5 3 × 3/8	4	10	8,000	3	10,000	2
E 11, ".....	40	151/2	5 3 × 3/8	33/4	93/4	10,600	3	12,200	2
E 12, ".....	34	151/2	5 3 × 3/8	33/4	93/4	13,100	3	15,780	2
E 13, Double.....	30	91/2	5 4 × 3/8	33/4	9	5,600	2	10,600	.....
E 14, ".....	40	91/2	6 4 × 11/32	33/8	9	6,840	2	8,600	.....
E 15, Quadruple..	36	151/2	6 3 × 11/32	37/16	93/4	11,820	21/2	14,370	2
E 16, ".....	30	151/2	6 3 × 11/32	41/2	101/8	8,000	23/4	15,500	.....
E 17, Double.....	36	91/2	5 4 × 3/8	23/4	8	8,070	2	9,540	.....
E 18, Single †.....	42	.....	9 31/2 × 3/8	1*	.....	5,250	0	7,300	.....
E 19, Double.....	22	101/2	6 41/2 × 11/32	13/16	67/16	13,800	.....	.....	.....
E 20, ".....	22	101/2	7 41/2 × 11/32	13/16	71/8	15,600	.....	.....	.....
E 21, ".....	24	101/2	7 41/2 × 3/8	1	71/4	15,750	0	28,800	.....
E 22, ".....	24	101/2	8 41/2 × 3/8	1	81/2	18,000	0	32,930	.....
E 23, ".....	36	10	5 4 × 3/8	21/4	8	8,750	11/4	10,750	.....
E 24, ".....	36	10	5 4 × 3/8	21/4	8	7,500	11/4	9,500	.....

(a) Between bands; (b) over all; a.p.t., auxiliary plates touching.

\* Between bottom of eye and top of leaf. † Semi-elliptical.

Tracings are furnished for each class of spring.

SPRINGS TO RESIST TORSIONAL FORCE.

(Reuleaux's Constructor.)

$$\begin{aligned}
 \text{Flat spiral or helical spring } P &= \frac{S bh^2}{6 R}; & f = R\phi &= 12 \frac{PlR^3}{Ebh^3}. \\
 \text{Round helical spring.....} P &= \frac{S\pi d^3}{32 R}; & f = R\phi &= \frac{64 Pl R^2}{\pi E d^4}. \\
 \text{Round bar, in torsion.....} P &= \frac{S\pi d^3}{16 R}; & f = R\phi &= \frac{32 P R^2 l}{\pi G d^4}. \\
 \text{Flat bar, in torsion.....} P &= \frac{S}{3R} \frac{b^2 h^2}{\sqrt{b^2 + h^2}}; & f = R\phi &= \frac{3PR^2 l}{G} \frac{b^2 + h^2}{b^3 h^3}.
 \end{aligned}$$

$P$  = force applied at end of radius or lever-arm  $R$ ;  $\phi$  = angular motion at end of radius  $R$ ;  $S$  = permissible maximum stress, =  $4/5$  of permissible stress in flexure;  $E$  = modulus of elasticity in tension;  $G$  = torsional modulus, =  $2/5 E$ ;  $l$  = developed length of spiral, or length of bar;  $d$  = diameter of wire;  $b$  = breadth of flat bar;  $h$  = thickness.

(Compare Elastic Resistance to Torsion, p. 334.)

**HELICAL SPRINGS — SIZES AND CAPACITIES.**

(Selected from Specifications of Penna. R. R. Co., 1899.)

P. R. R. Co.'s Class.	Diam. of Bar, ins.	Length of Bar, ins.	Tapered to ins.	Normal Weight.		Outside Diam. of Coil, ins.	Test. Height and Loads.				Capacity of Single Coil, lbs.
				lbs.	oz.		Free, ins.	Solid, ins.	Ins. with	Load of lbs.	
H 26	9/64	571/2	59	0	4	1	53/4	3	31/4	110	130
M 18	11/64	75	761/4	0	8	1	8	5	6	170	270
H 55	3/16	451/8	465/16	0	55/8	1	41/2	35/16	4	103	245
H 73	3/16	426	4273/4	3	51/2	15/16	39	221/2	35	45	185
H 29	7/32	201/2	227/16	0	31/2	115/32	111/16	19/64	13/8	110	200
H 1	1/4	451/2	47	0	10	11/4	51/8	35/8	43/8	250	500
H 5	1/4	251/4	281/4	0	6	21/4	21/4	11/8	11/2	164	240
H 58	5/16	2531/2	2561/2	5	7	21/4	23	13	18	248	495
H 74	5/16	180	1821/8	3	141/2	111/16	191/8	13	141/8	587	700
H 681*	3/8	991/2	1031/4	3	11/2	23/4	9	5	7	350	700
H 79	3/8	88	903/4	2	12	21/8	85/8	6	63/4	676	946
H 802	13/32	1923/8	1953/4	7	11/2	29/16	18	119/16	151/2	380	975
H 43	7/16	96	1025/16	4	1	47/16	815/16	33/8	51/8	450	660
H 64	7/16	755/8	781/2	3	3	29/32	75/8	55/8	53/4	1350	1440
H 532	15/32	1695/16	1729/16	8	4	217/32	161/2	121/4	151/2	330	1410
H 272	1/2	903/4	951/8	5	0	31/4	81/2	51/4	63/4	810	1500
H 61	1/2	151/2	213/8	0	133/4	41/4	13/8	05/8	1	532	1050
H 19	17/32	811/2	851/2	5	2	31/32	8	59/16	67/16	1200	1900
H 863	17/32	1535/8	159	9	10	4	133/4	71/2	87/16	1156	1360
H 62	9/16	98	103	6	15	33/4	91/8	51/2	7	1050	1800
H 333	9/16	801/4	847/8	5	101/2	31/4	8	53/8	613/16	1000	2200
H 592	5/8	741/4	773/4	6	7	27/8	81/4	69/16	71/4	2100	3500
H 801	5/8	1921/2	1973/4	16	11	315/16	18	119/16	151/2	900	2315
H 722	21/32	601/8	631/2	5	117/8	23/4	75/16	6	63/8	3260	4240
H 152	11/16	557/8	593/4	5	14	31/2	53/4	45/16	53/16	1400	3500
H 41	11/16	1171/2	1231/2	12	10	41/2	107/8	63/4	85/8	1500	2720
H 40	3/4	1771/2	1865/8	22	21/2	61/2	16	73/8	87/8	1900	2300
H 70	3/4	62	66	7	12	33/8	7	55/8	61/4	2750	5050
H 172	13/16	100	1063/4	14	12	51/8	91/8	6	75/8	1700	3700
H 662	13/16	1051/4	1103/8	15	7	45/32	107/8	81/8	87/8	3670	5040
H 37	27/32	77	817/8	12	21/2	315/16	81/2	611/16	71/2	3300	6250
H 872	27/32	13013/16	13715/16	20	9	53/8	121/4	73/4	87/16	3540	4165
H 122	7/8	85	911/2	14	7	5	81/2	53/4	73/8	2000	5200
H 332	7/8	82	8811/16	13	15	51/8	8	53/8	613/16	2250	5000
H 2	15/16	46	523/8	8	151/4	5	45/8	33/8	4	3250	7000
H 16	15/16	85	927/8	16	10	6	8	5	6	3600	5100
H 10	1	85	92	18	14	51/2	81/2	6	7	4500	7000
H 421	1	36	427/8	8	0	53/8	35/8	25/8	33/8	1795	7180
H 4	11/16	987/8	105	24	12	5	107/8	81/2	93/8	6000	9570
H 861	11/16	1535/8	1641/2	38	9	8	133/4	71/2	87/16	4624	5440
H 3	11/8	353/8	411/4	9	15	47/8	41/8	33/8	33/4	6000	12000
H 141	11/8	51	587/8	14	4	61/8	51/8	311/16	43/16	5000	8950
H 61	13/16	991/8	1093/4	31	1	8	91/8	51/2	7	4550	7750
H 47	13/16	731/2	791/2	23	0	57/16	81/4	69/16	71/4	7400	12500
H 9	11/4	971/2	108	33	12	8	9	53/4	71/2	4000	9100
H 721	11/4	621/8	683/4	21	81/2	53/8	75/16	6	63/8	10700	14875
H 8	15/16	96	1061/2	36	12	8	91/8	6	71/4	6350	10600
H 62	15/16	70	771/16	26	12	513/16	8	61/2	71/4	7900	15800
H 121	13/8	87	973/8	36	7	8	81/2	53/4	73/8	5000	12200
H 391	13/8	755/8	831/2	31	11	63/8	83/8	65/8	71/2	8150	16300
H 281	113/32	8411/16	95	37	3	8	81/4	53/4	67/8	7325	13250

\* The subscript 1 means the outside coil of a concentric group of cluster; 2 and 3 are inner coils.

**Phosphor-Bronze Springs.** Wilfred Lewis (Engs'. Club, Phila., 1887) made some tests of a helical spring of phosphor-bronze wire, 0.12 in. diameter,  $1\frac{1}{4}$  in. diameter from center to center, making 52 coils.

Such a spring of steel, according to the practice of the P. R. R., might be used for 40 lbs. A load of 30 lbs. gradually applied gave a permanent set. With a load of 21 lbs. in 30 hours the spring lengthened from  $20\frac{5}{8}$  inches to  $21\frac{1}{8}$  inches, and in 200 hours to  $21\frac{1}{4}$  inches. It was concluded that 21 lbs. was too great for durability. For a given load the extension of the bronze spring was just double the extension of a similar steel spring, that is, for the same extension the steel spring is twice as strong.

**Chromium-Vanadium Spring Steel.** (*Proc. Inst. M. E.*, 1904, pp 1263, 1305.) — A spring steel containing C, 0.44; Si, 0.173; Mn, 0.837; Cr, 1.044; Va, 0.188 was made into a spring with dimensions as follows: length unstretched 9.6 in., mean diam. of coils ( $D$ ) 5.22; No. of coils ( $n$ ) 4; diam. of wire, ( $d$ ) 0.561. It was tempered in the usual way. When stretched it showed signs of permanent set at about 1900 lbs. Compared with two springs of ordinary steels the following formulæ are obtained:

Load at which Permanent Set begins. Extension for a load  $W$ .

Chrome-Vanadium Spring...  $56,300 d^3/D$  lbs.  $WnD^3 + 1,468,000 d^4$

West Bromwich Spring.....  $28,400 d^3/D$  "  $WnD^3 + 1,575,000 d^4$

Turton & Platt Spring.....  $44,200 d^3/D$  "  $WnD^3 + 1,331,600 d^4$

**Test of a Vanadium-steel Spring.** (Circular of the American Vanadium Co., 1908). — Comparative tests of an ordinary carbon-steel locomotive flat spring and of a vanadium-steel spring, made by the American Locomotive Co., showed the following: The vanadium spring, on 36-in. centers tested to 94,000 lbs., reached its elastic limit at 85,000 lbs., or 234,000 lbs. per sq. in. fiber stress, and a permanent set of 0.48 in. The test was repeated three times without change in the deflection. The carbon spring was tested to 89,280 lbs. and reached an elastic limit at 65,000 lbs., or 180,000 lbs. fiber stress, with a permanent set of 1.12 in. On repeating the test it took an additional set of 0.25 in., and on the next test several of the plates failed.

## RIVETED JOINTS.

**Fairbairn's Experiments.** — The earliest published experiments on riveted joints are contained in the memoir by Sir W. Fairbairn in the Transactions of the Royal Society. Making certain empirical allowances, he adopted the following ratios as expressing the relative strength of riveted joints:

Solid plate.....	100
Double-riveted joint.....	70
Single-riveted joint.....	56

These celebrated ratios appear to rest on a very unsatisfactory analysis of the experiments on which they were based.

**Loss of Strength in Punched Plates.** (*Proc. Inst. M. E.*, 1881.) — A report by Mr. W. Parker and Mr. John, made in 1878 to Lloyd's Committee, on the effect of punching and drilling, showed that thin steel plates lost comparatively little from punching, but that in thick plates the loss was very considerable. The following table gives the results for plates punched and not annealed or reamed:

Thickness of plates.....	$\frac{1}{4}$	$\frac{3}{8}$	$\frac{1}{2}$	$\frac{3}{4}$
Loss of tenacity, per cent.....	8	18	26	33

When  $\frac{7}{8}$ -in. punched holes were reamed out to  $1\frac{1}{8}$  in. diameter, the loss of tenacity disappeared, and the plates carried as high a stress as drilled plates. Annealing also restores to punched plates their original tenacity.

The Report of the Research Committee of the Institution of Mechanical Engineers, on Riveted Joints (1881), and records of investigations by Prof. A. B. W. Kennedy (1881, 1882, and 1885), summarize the existing information regarding the comparative effects of punching and drilling upon iron and steel plates. An examination of the voluminous tables given in Professor Unwin's Report, of the experiments made on iron and steel plates, leads to the general conclusion that, while thin plates, even of steel, do not suffer very much from punching, yet in those of  $\frac{1}{2}$  inch thickness and upwards the loss of tenacity due to punching ranges from 10% to 23% in iron plates, and from 11% to 33% in the case of mild steel. In drilled plates there is no appreciable loss of strength. It is



possible to remove the bad effects of punching by subsequent reaming or annealing. The introduction of a practicable method of drilling the plating of ships and other structures, after it has been bent and shaped, is a matter of great importance. In the modern English practice (1887) of the construction of steam-boilers with steel plates punching is almost entirely abolished, and all rivet-holes are drilled after the plates have been bent to the desired form.

**Strength of Perforated Plates.** (P. D. Bennett, *Eng'g*, Feb. 12, 1886, p. 155.) — Tests were made to determine the relative effect produced upon tensile strength of a flat bar of iron or steel: 1. By a 3/4-inch hole drilled to the required size; 2. By a hole punched 1/8 inch smaller and then drilled to the size of the first hole; and, 3. By a hole punched in the bar to the size of the drilled hole. The relative results in strength per square inch of original area were as follows:

	1.	2.	3.	4.
	Iron.	Iron.	Steel.	Steel.
Unperforated bar.....	1.000	1.000	1.000	1.000
Perforated by drilling.....	1.029	1.012	1.068	1.103
Perforated by punching and drilling	1.030	1.008	1.059	1.110
Perforated by punching only.....	0.795	0.894	0.935	0.927

In tests 2 and 4 the holes were filled with rivets driven by hydraulic pressure. The increase of strength per square inch caused by drilling is a phenomenon of similar nature to that of the increased strength of a grooved bar over that of a straight bar of sectional area equal to the smallest section of the grooved bar. Mr. Bennett's tests on an iron bar 0.84 in. diameter, 10 in. long, and a similar bar turned to 0.84 in. diameter at one point only, showed that the relative strength of the latter to the former was 1.323 to 1.000.

**Comparative Efficiency of Riveting done by Different Methods.**

The Reports of Professors Unwin and Kennedy to the Institution of Mechanical Engineers (*Proc.* 1881, 1882, and 1885) tend to establish the four following points:

1. That the shearing resistance of rivets is not highest in joints riveted by means of the greatest pressure;
2. That the ultimate strength of joints is not affected to an appreciable extent by the mode of riveting; and, therefore,
3. That very great pressure upon the rivets in riveting is not the indispensable requirement that it has been sometimes supposed to be;
4. That the most serious defect of hand-riveted as compared with machine-riveted work consists in the fact that in hand-riveted joints visible slip commences at a comparatively small load, thus giving such joints a low value as regards tightness, and possibly also rendering them liable to failure under sudden strains after slip has once commenced.

The following figures of mean results give a comparative view of hand and hydraulic riveting, as regards their ultimate strengths in joints, and the periods at which in both cases visible slip commenced.

Total breaking load. Tons....	{ Hand.....	86.01	82.16	149.2	193.6
	{ Hydraulic.....	85.75	82.70	145.5	183.1
Load at which visible slip began	{ Hand.....	21.7	25.0	31.7	25.0
	{ Hydraulic.....	47.5	53.7	49.7	56.0

**Some of the Conclusions of the Committee of Research on Riveted Joints.**

(*Proc. Inst. M. E.*, April, 1885.)

The conclusions refer to joints made in soft steel plate with steel rivets, the holes drilled, and the plates in their natural state (unannealed). The rivet or shearing area has been assumed to be that of the holes, not the area of the rivets themselves. The strength of the metal in the joint has been compared with that of strips cut from the same plates.

The metal between the rivet-holes has a considerably greater tensile resistance per square inch than the unperforated metal. This excess tenacity amounted to more than 20%, both in  $\frac{3}{8}$ -inch and  $\frac{3}{4}$ -inch plates, when the pitch of the rivet was about 1.9 diameters. In other cases  $\frac{3}{8}$ -inch plate gave an excess of 15% at fracture with a pitch of 2 diameters, of 10% with a pitch of 3.6 diameters, and of 6.6%, with a pitch of 3.9 diameters; and  $\frac{3}{4}$ -inch plate gave 7.8% excess with a pitch of 2.8 diameters.

In single-riveted joints it may be taken that about 22 tons per square inch is the shearing resistance of rivet steel, when the pressure on the rivets does not exceed about 40 tons per square inch. In double-riveted joints, with rivets of about  $\frac{3}{4}$ -inch diameter, most of the experiments gave about 24 tons per square inch as the shearing resistance, but the joints in one series went at 22 tons. [Tons of 2240 lbs.]

The ratio of shearing resistance to tenacity is not constant, but diminishes very markedly and not very irregularly as the tenacity increases.

The size of the rivet heads and ends plays a most important part in the strength of the joints — at any rate in the case of single-riveted joints. An increase of about one-third in the weight of the rivets (all this increase, of course, going to the heads and ends) was found to add about 8 $\frac{1}{2}$ % to the resistance of the joint, the plates remaining unbroken at the full shearing resistance of 22 tons per square inch, instead of tearing at a shearing stress of only a little over 20 tons. The additional strength is probably due to the prevention of the distortion of the plates by the great tensile stress in the rivets.

The intensity of bearing pressure on the rivet exercises, with joints proportioned in the ordinary way, a very important influence on their strength. So long as it does not exceed 40 tons per square inch (measured on the projected area of the rivets), it does not seem to affect their strength; but pressures of 50 to 55 tons per square inch seem to cause the rivets to shear in most cases at stresses varying from 16 to 18 tons per square inch. For ordinary joints, which are to be made equally strong in plate and in rivets, the bearing pressure should therefore probably not exceed 42 or 43 tons per square inch. For double-riveted butt-joints perhaps, as will be noted later, a higher pressure may be allowed, as the shearing stress may probably not be more than 16 or 18 tons per square inch when the plate tears.

A margin (or net distance from outside of holes to edge of plate) equal to the diameter of the drilled hole has been found sufficient in all cases hitherto tried.

To attain the maximum strength of a joint, the breadth of lap must be such as to prevent it from breaking zigzag. It has been found that the net metal measured zigzag should be from 30% to 35% in excess of that measured straight across, in order to insure a straight fracture. This corresponds to a diagonal pitch of  $\frac{2}{3}p + d/3$ , if  $p$  be the straight pitch and  $d$  the diameter of the rivet-hole.

Visible slip or "give" occurs always in a riveted joint at a point very much below its breaking load, and by no means proportional to that load. A collation of the results obtained in measuring the slip indicates that it depends upon the number and size of the rivets in the joint, rather than upon anything else; and that it is tolerably constant for a given size of rivet in a given type of joint. The loads per rivet at which a joint will commence to slip visibly are approximately as follows:

Diameter of Rivet.	Type of Joint.	Riveting.	Slipping Load per Rivet.
$\frac{3}{4}$ inch	Single-riveted	Hand	2.5 tons
$\frac{3}{4}$ "	Double-riveted	Hand	3.0 to 3.5 tons
$\frac{3}{4}$ "	Double-riveted	Machine	7 tons
1 inch	Single-riveted	Hand	3.2 tons
1 "	Double-riveted	Hand	4.3 tons
1 "	Double-riveted	Machine	8 to 10 tons

To find the probable load at which a joint of any breadth will commence to slip, multiply the number of rivets in the given breadth by the proper figure taken from the last column of the table above. The above figures are not given as exact; but they represent the results of the experiments.

The experiments point to simple rules for the proportioning of joints of maximum strength. Assuming that a bearing pressure of 43 tons per square inch may be allowed on the rivet, and that the excess tenacity of the plate is 10% of its original strength, the following table gives the values of the ratios of diameter  $d$  of hole to thickness  $t$  of plate ( $d + t$ ), and of pitch  $p$  to diameter of hole ( $p \div d$ ) in joints of maximum strength in  $3/8$ -inch plate.

For Single-riveted Plates.

Original Tenacity of Plate.		Shearing Resistance of Rivets.		Ratio. $d+t$	Ratio. $p \div d$	Ratio. $\frac{\text{Plate Area}}{\text{Rivet Area}}$
Tons per Sq. In.	Lbs. per Sq. In.	Tons per Sq. In.	Lbs. per Sq. In.			
30	67,200	22	49,200	2.48	2.30	0.667
28	62,720	22	49,200	2.48	2.40	0.785
30	67,200	24	53,760	2.28	2.27	0.713
28	62,720	24	53,760	2.28	2.36	0.690

This table shows that the diameter of the hole should be  $2\frac{1}{3}$  times the thickness of the plate, and the pitch of the rivets  $2\frac{3}{8}$  times the diameter of the hole. Also, it makes the mean plate area 71% of the rivet area. If a smaller rivet be used than that here specified, the joint will not be of uniform, and therefore not of maximum, strength; but with any other size of rivet the best result will be got by use of the pitch obtained from the simple formula  $p = ad^2/t + d$ , where, as before,  $d$  is the diameter of the hole.

The value of the constant  $a$  in this equation is as follows:

For 30-ton plate and 22-ton rivets, $a = 0.524$
“ 28 “ “ “ 22 “ “ “ 0.558
“ 30 “ “ “ 24 “ “ “ 0.570
“ 28 “ “ “ 24 “ “ “ 0.606

Or, in the mean, the pitch  $p = 0.56 \frac{d^2}{t} + d$ . With too small rivets this gives pitches often considerably smaller in proportion than  $2\frac{3}{8}$  times the diameter.

For double-riveted lap-joints a similar calculation to that given above, but with a somewhat smaller allowance for excess tenacity, on account of the large distance between the rivet-holes, shows that for joints of maximum strength the ratio of diameter to thickness should remain precisely as in single-riveted joints; while the ratio of pitch to diameter of hole should be 3.64 for 30-ton plates and 22 or 24 ton rivets, and 3.82 for 28-ton plates with the same rivets.

Here, still more than in the former case, it is likely that the prescribed size of rivet may often be inconveniently large. In this case the diameter of rivet should be taken as large as possible; and the strongest joint for a given thickness of plate and diameter of hole can then be obtained by using the pitch given by the equation  $p = ad^2/t + d$ , where the values of the constant  $a$  for different strengths of plates and rivets may be taken as follows, for any thickness of plate from  $3/8$  to  $3/4$ -inch:

For 30-ton plate and 24-ton rivets } $p = 1.16 \frac{d^2}{t} + d$ ;
“ 28 “ “ “ 22 “ “ } $p = 1.06 \frac{d^2}{t} + d$ ;
“ 30 “ “ “ 22 “ “ } $p = 1.24 \frac{d^2}{t} + d$ .
“ 28 “ “ “ 24 “ “ } $p = 1.24 \frac{d^2}{t} + d$ .



In double-riveted butt-joints it is impossible to develop the full shearing resistance of the joint without getting excessive bearing pressure, because the shearing area is doubled without increasing the area on which the pressure acts. Considering only the plate resistance and the bearing pressure, and taking this latter as 45 tons per square inch, the best pitch would be about 4 times the diameter of the hole. We may probably say with some certainty that a pressure of from 45 to 50 tons per square inch on the rivets will cause shearing to take place at from 16 to 18 tons per square inch. Working out the equations as before, but allowing excess strength of only 5% on account of the large pitch, we find that the proportions of double-riveted butt-joints of maximum strength, under given conditions, are those of the following table:

Double-riveted Butt-joints.

Original Tenacity of Plate, Tons per Sq. In.	Shearing Resistance of Rivets, Tons per Sq. In.	Bearing Pressure, Tons per Sq. In.	Ratio $\frac{d}{t}$	Ratio $\frac{p}{d}$
30	16	45	1.80	3.85
28	16	45	1.80	4.06
30	18	48	1.70	4.03
28	18	48	1.70	4.27
30	16	50	2.00	4.20
28	16	50	2.00	4.42

Practically, therefore, it may be said that we get a double-riveted butt-joint of maximum strength by making the diameter of hole about 1.8 times the thickness of the plate, and making the pitch 4.1 times the diameter of the hole.

The proportions just given belong to joints of maximum strength. But in a boiler the one part of the joint, the plate, is much more affected by time than the other part, the rivets. It is therefore not unreasonable to estimate the percentage by which the plates might be weakened by corrosion, etc., before the boiler would be unfit for use at its proper steam-pressure, and to add correspondingly to the plate area. Probably the best thing to do in this case is to proportion the joint, not for the actual thickness of plate, but for a nominal thickness less than the actual by the assumed percentage. In this case the joint will be approximately one of uniform strength by the time it has reached its final workable condition; up to which time the joint as a whole will not really have been weakened, the corrosion only gradually bringing the strength of the plates down to that of rivets.

#### Efficiencies of Joints.

The average results of experiments by the committee gave: For double-riveted lap-joints in  $\frac{3}{8}$ -inch plates, efficiencies ranging from 67.1% to 81.2%. For double-riveted butt-joints (in double shear) 61.4% to 71.3%. These low results were probably due to the use of very soft steel in the rivets. For single-riveted lap-joints of various dimensions the efficiencies varied from 54.8% to 60.8%. The shearing resistance of steel did not increase nearly so fast as its tensile resistance. With very soft steel, for instance, of only 26 tons tenacity, the shearing resistance was about 80% of the tensile resistance, whereas with very hard steel of 52 tons tenacity the shearing resistance was only somewhere about 65% of the tensile resistance.

#### Proportions of Pitch and Overlap of Plates to Diameter of Rivet-Hole and Thickness of Plate.

(Prof. A. B. W. Kennedy, *Proc. Inst. M. E.*, April, 1885.)

- $t$  = thickness of plate;
- $d$  = diameter of rivet (actual) in parallel hole;
- $p$  = pitch of rivets, center to center;
- $s$  = space between lines of rivets;
- $l$  = overlap of plate.



(1) Lloyd's Rules. (2) Liverpool Rules. (3) English Dock-yards. (4) French Veritas. (5) Hartford Steam Boiler Inspection and Insurance Co., double riveted lap-joints. (6) Ditto, triple-riveted butt-joints. (7) F. E. Cardullo. ( $\frac{1}{16}$  less than diam. of hole.)

**Calculated Efficiencies — Steel Plates and Steel Rivets.**— The following table has been calculated by the author on the assumptions that the excess strength of the perforated plate is 10%, and that the shearing strength of the rivets per square inch is four-fifths of the tensile strength of the plate (or, if no allowance is made for excess strength of the perforated plate that the shearing strength is 72.7% of the tensile strength). If  $t$  = thickness of plate,  $d$  = diameter of rivet-hole,  $p$  = pitch, and  $T$  = tensile strength per square inch, then for single-riveted plates

$$(p - d)t \times 1.10T = \frac{\pi}{4} d^2 \times \frac{4}{5} T, \text{ whence } p = 0.571 \frac{d^2}{t} + d.$$

$$\text{For double-riveted lap-joints, } p = 1.142 \frac{d^2}{t} + d.$$

The coefficients 0.571 and 1.142 agree closely with the averages of those given in the report of the committee of the Institution of Mechanical Engineers, quoted on page 427, *ante*.

Thickness.	Diam. of Rivet-hole.	Pitch.		Efficiency.		Thickness.	Diam. of Rivet-hole.	Pitch.		Efficiency.	
		Single Riveting.	Double Riveting.	Single Riveting.	Double Riveting.			Single Riveting.	Double Riveting.	Single Riveting.	Double Riveting.
in.	in.	in.	in.	%	%	in.	in.	in.	in.	%	%
$\frac{3}{16}$	$\frac{7}{16}$	1.020	1.603	57.1	72.7	$\frac{1}{2}$	$\frac{3}{4}$	1.392	2.035	46.1	63.1
$\frac{3}{16}$	$\frac{1}{2}$	1.261	2.023	60.5	75.3	$\frac{1}{2}$	$\frac{7}{8}$	1.749	2.624	50.0	66.6
$\frac{1}{4}$	$\frac{1}{2}$	1.071	1.642	53.3	69.6	$\frac{1}{2}$	1	2.142	3.284	53.3	70.0
$\frac{1}{4}$	$\frac{9}{16}$	1.285	2.008	56.2	72.0	$\frac{1}{2}$	$\frac{11}{8}$	2.570	4.016	56.2	72.0
$\frac{5}{16}$	$\frac{9}{16}$	1.137	1.712	50.5	67.1	$\frac{5}{16}$	$\frac{3}{4}$	1.321	1.892	43.2	60.3
$\frac{5}{16}$	$\frac{5}{8}$	1.339	2.053	53.3	69.5	$\frac{9}{16}$	$\frac{7}{8}$	1.652	2.429	47.0	64.0
$\frac{5}{16}$	$\frac{11}{16}$	1.551	2.415	55.7	71.5	$\frac{9}{16}$	1	2.015	3.030	50.4	67.0
$\frac{3}{8}$	$\frac{5}{8}$	1.218	1.810	48.7	65.5	$\frac{9}{16}$	$\frac{11}{8}$	2.410	3.694	53.3	69.5
$\frac{3}{8}$	$\frac{3}{4}$	1.607	2.463	53.3	69.5	$\frac{9}{16}$	$\frac{11}{4}$	2.836	4.422	55.9	71.5
$\frac{3}{8}$	$\frac{7}{8}$	2.041	3.206	57.1	72.7	$\frac{5}{8}$	$\frac{3}{4}$	1.264	1.778	40.7	57.8
$\frac{7}{16}$	$\frac{5}{8}$	1.136	1.647	45.	62.0	$\frac{5}{8}$	$\frac{7}{8}$	1.575	2.274	44.4	61.5
$\frac{7}{16}$	$\frac{3}{4}$	1.484	2.218	49.5	66.2	$\frac{7}{16}$	1	1.914	2.827	47.7	64.6
$\frac{7}{16}$	$\frac{7}{8}$	1.869	2.864	53.2	69.4	$\frac{5}{8}$	$\frac{11}{8}$	2.281	3.438	50.7	67.3
$\frac{7}{16}$	1	2.305	3.610	56.6	72.3	$\frac{5}{8}$	$\frac{11}{4}$	2.678	4.105	53.3	69.5

### Apparent Shearing Resistance of Rivet Iron and Steel.

(*Proc. Inst. M. E.*, 1879, *Engineering*, Feb. 20, 1880.)

The true shearing resistance of the rivets cannot be ascertained from experiments on riveted joints (1) because the uniform distribution of the load to all the rivets cannot be insured; (2) because of the friction of the plates, which has the effect of increasing the apparent resistance to shearing in an element uncertain in amount. Probably in the case of single-riveted joints the shearing resistance is not much affected by the friction.

Fairbairn's experiments show that a rivet is  $6\frac{1}{2}\%$  weaker in a drilled than in a punched hole. By rounding the edge of the rivet-hole, the apparent shearing resistance is increased 12%. Messrs. Greig and Eyth's experiments indicate a greater resistance of the rivets in punched holes than in drilled holes.

If the apparent shearing resistance is less for double than for single shear, it is probably due to unequal distribution of the stress on the two rivet sections.



The shearing resistance of a bar, when sheared in circumstances which prevent friction, is usually less than the tenacity of the bar. The following results show the decrease:

Harkort, iron.....	Tenacity, 26.4	Shearing, 16.5	Ratio, 0.62
Lavalley, iron.....	" 25.4	" 20.2	" 0.79
Greig and Eyth, iron.	" 22.2	" 19.0	" 0.85
Greig and Eyth, steel	" 28.8	" 22.1	" 0.77

In Wöhler's researches (in 1870) the shearing strength of iron was found to be four-fifths of the tenacity. Later researches of Bauschinger confirm this result generally, but they show that for iron the ratio of the shearing resistance and tenacity depends on the direction of the stress relatively to the direction of rolling. The above ratio is valid only if the shear is in a plane perpendicular to the direction of rolling, and if the tension is applied parallel to the direction of rolling. If the plane of shear is parallel to the breadth of the bar, the resistance is only half as great as in a plane perpendicular to the fibers.

**THE STRENGTH OF RIVETED JOINTS.**

**Joint of Maximum Efficiency.** — (F. E. Cardullo.) If a riveted joint is made with sufficient lap, and a proper distance between the rows of rivets, it will break in one of the three following ways:

1. By tearing the plate along a line, through the outer row of rivets.
2. By shearing the rivets.
3. By crushing the plate or the rivets.

Let  $t$  = the thickness of the main plates.

$d$  = the diameter of the rivet-holes.

$f$  = the tensile strength of the plate in pounds per sq. in.

$s$  = the shearing strength of the rivets in pounds per sq. in. when in single shear.

$p$  = the distance between the centers of rivets of the outer row (see Figs. 96 and 97) = the pitch in single and double lap riveting = twice

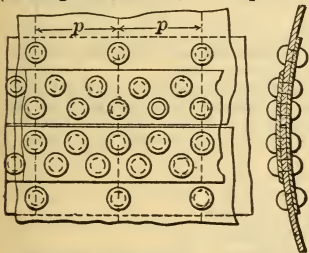

FIG. 96.  
TRIPLE RIVETING.

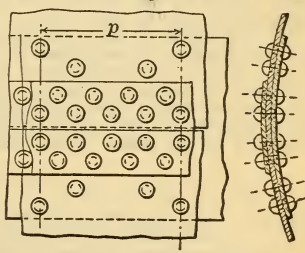

FIG. 97.  
QUADRUPLE RIVETING.

the pitch of the inner rows in triple butt strap riveting, in which alternate rivets in the outer row are omitted, = four times the pitch in quadruple butt strap riveting, in which the outer row has one-fourth of the number of rivets of the two inner rows.

$c$  = the crushing strength of the rivets or plates in pounds per sq. in.

$n$  = the number of rivets in each group in single shear. (A group is the number of rivets on one side of a joint corresponding to the distance  $p$ ; = 1 rivet in single riveting, 2 in double riveting, 5 in triple butt strap riveting, and 11 in quadruple butt strap riveting.)

$m$  = the number of rivets in each group in double shear.

$s'$  = the shearing strength of rivets in double shear, in pounds per sq. in., the rivet section being counted once.

$T$  = the strength of the plate at the weakest section. =  $ft(p - d)$ .

$S$  = the strength of the rivets against shearing, =  $0.7854 d^2 (ns + ms')$ .

$C$  = the strength of the rivets or the plates against crushing, =  $d^2 c (n + m)$ .

In order that the joint shall have the greatest strength possible, the tearing, shearing, and crushing strength must all be equal. In order to make it so,

1. Substitute the known numerical values, equate the expressions for shearing and crushing strength, and find the value of  $d$ , taking it to the nearest  $\frac{1}{16}$  in.

2. Next find the value of  $S$  in the second equation, and substitute it for  $T$  in the first equation. Substitute numerical values for the other factors in the first equation, and solve for  $p$ .

The efficiency of a riveted joint in tearing, shearing and crushing, is equal to the tearing, shearing or crushing strength, divided by the quantity  $ftp$ , or the strength of the solid plate.

The efficiency in tearing is also equal to  $(p - d) \div p$ .

The maximum possible efficiency for a well-designed joint is

$$E = \frac{m + n}{m + n + (f \div c)}$$

Empirical formula for the diameter of the rivet-hole when the crushing strength is unknown. Assuming that  $c = 1.4f$ , and  $s'' = 1.75s$ , we have by equating  $C$  and  $S$ , and substituting,

$$d = 1.782t \frac{f(n + m)}{s(n + 1.75m)}$$

Margin. The distance from the center of any rivet-hole to the edge of the plate should be not less than  $1\frac{1}{2}d$ . The distance between two adjacent rivet centers should be not less than  $2d$ . It is better to increase each of these dimensions by  $\frac{1}{8}$  in.

The distance between the rows of rivets should be such that the net section of plate material along any broken diagonal through the rivet-holes should be not less than 30 per cent greater than the plate section along the outer line of rivets.

The thickness of the inner cover strap of a butt joint should be  $\frac{3}{4}$  of the thickness of the main plate or more. The thickness of the outer strap should be  $\frac{5}{8}$  of the thickness of the main plate or more.

Steam Tightness. It is of great importance in boiler riveting that the joint be steam tight. It is therefore necessary that the pitch of the rivets nearest to the calked edge be limited to a certain function of the thickness of the plate. The Board of Trade rule for steam tightness is

$$p = Ct + 1\frac{5}{8} \text{ in.}$$

where  $p$  = the maximum allowable pitch in inches.

$t$  = the thickness of main plate in inches.

$C$  = a constant from the following table.

No. of Rivets per Group...	1	2	3	4	5
Lap Joints.....	$C = 1.31$	2.62	3.47	4.14	...
Double-straped Joints....	$C = 1.75$	3.50	4.63	5.52	6.00

The pitch should not exceed ten inches under any circumstances.

When the joint has been designed for strength, it should be checked by the above formula. Should the pitch for strength exceed the pitch for steam tightness, take the latter, substitute it in the formula

$$ft(p - d) = 0.7854d^2(ns + ms''),$$

and solve for  $d$ . If the value of  $d$  so obtained is not the diameter of some standard size rivet, take the next larger  $\frac{1}{16}$  in.

**Calculation of Triple-riveted Butt and Strap Joints.** — Formulæ:  $T = ft(p - d)$ ,  $S = 0.7854d^2(ns + ms'')$ ,  $C = dtc(m + n)$  (notation on preceding page),  $n = 1$ ,  $m = 4$ .

Take  $f = 55,000$ ;  $s = 0.8f$ ,  $= 44,000$ ;  $s'' = 1.75s = 77,000$ ,  $c = 1.4f = 77,000$ .

Then  $T = 55,000t(p - d)$ ,  $S = 276,460d^2$ ,  $C = 385,000dt$ .

For maximum strength,  $T = S = C$ ; dividing by  $55,000t$ ,  $(p - d) = 5.027d = 7d$ ; whence  $d = 1.3925t$ ;  $p = 8d$ .

Thickness of plate, $t = \frac{5}{16}$	$\frac{3}{8}$	$\frac{7}{16}$	$\frac{1}{2}$	$\frac{9}{16}$	$\frac{5}{8}$	
Diam. rivet hole, $d = 1.3925t$ . . . . .	0.4353	0.5222	0.6092	0.6962	0.7833	0.8703
Pitch of outer row, $p = 8d$ . . . . .	3.4816	4.1776	4.8736	5.5696	6.2664	6.9624
$T = 55,000t(p - d)$	52,360	75,390	102,610	134,020	169,630	209,420
$S = 276,460d^2$ . . . . .	52,330	75,360	102,570	133,970	169,560	209,330
$C = 385,000d^2$ . . . . .	52,350	75,390	102,620	134,030	169,630	209,420

Calculations by logarithms, to nearest 10 pounds.

Efficiency of all joints  $(p - d) \div p = 87.5$  per cent.

Maximum efficiency by Cardullo's formula,  $\frac{n + m}{n + m + f/c} = \frac{5}{5 + 1/1.4} = 87.5$  per cent.

Diameter of rivet-hole, next largest 16th,  $\frac{7}{16}$   $\frac{9}{16}$   $\frac{5}{8}$   $\frac{3}{4}$   $\frac{13}{16}$   $\frac{7}{8}$   
 For the same thickness of plates the Hartford Steam Boiler Inspection and Insurance Co. gives the following proportions:

Thickness, $t$ ,	$\frac{5}{16}$	$\frac{3}{8}$	$\frac{7}{16}$	$\frac{1}{2}$	$\frac{9}{16}$	$\frac{5}{8}$
Diam. rivet-hole, $d$ ,	$\frac{3}{4}$	$\frac{13}{16}$	$\frac{15}{16}$	1	$\frac{11}{16}$	$\frac{11}{16}$
Pitch of outer row, $p$ ,	$6\frac{1}{4}$	$6\frac{1}{2}$	$6\frac{3}{4}$	$7\frac{1}{2}$	$7\frac{3}{4}$	$7\frac{3}{4}$

Using the same values for  $f$ ,  $s$ ,  $s''$  and  $c$ , we obtain:

$T =$ . . . . .	94,530	117,300	139,860	178,750	207,850	229,880
$S =$ . . . . .	155,400	168,400	194,300	207,300	220,200	220,200
$C =$ . . . . .	90,030	117,300	157,900	192,500	230,000	255,500

Strength of solid plate, $fpt =$ . . . . .	107,360	134,060	162,420	206,250	239,770	266,400
--	---------	---------	---------	---------	---------	---------

Efficiency $T, S$ or $C$ , lowest $\div fpt$ , per cent . . . . .	83.9	87.5	86.1	86.7	86.7	82.6
---	------	------	------	------	------	------

The  $\frac{5}{16}$  in. plate fails by crushing, the  $\frac{5}{8}$  by shearing, the others by tearing.

**Calculation of Quadruple Riveting.** — In this case there are 11 rivets in the group. If the upper strap plate contains all the rivets except the outer row, then  $n = 1$ ,  $m = 10$ . Using the same values for  $f$ ,  $s$ ,  $s''$  and  $c$  as above, we have  $ns + ms'' = 814,000$ ;  $T = 55,000t(p - d)$ ;  $S = 639,315d^2$ ;  $C = 847,000dt$ .

For maximum strength,  $t(p - d) = 11.624d^2 = 15.4dt$ ; whence  $d = 1.32485t$ ,  $p = 16.4d$ . Efficiency  $(p - d) \div p = 93.9$  per cent. Check by

Cardullo's formula  $\frac{n + m}{n + m + f/c} = \frac{11}{11 + 10/14} = 93.9$  per cent.

**British Board of Trade and Lloyd's Rules for Riveted Joints.** — *Board of Trade.* — Tensile strength of rivet bars between 26 and 30 tons, el. in 10" not less than 25%, and contr. of area not less than 50%.

The shearing resistance of the rivet steel to be taken at 23 tons per square inch, 5 to be used for the factor of safety independently of any addition to this factor for the plating. Rivets in double shear to have only 1.75 times the single section taken in the calculation instead of 2. The diameter must not be less than the thickness of the plate, and the pitch never greater than  $8\frac{1}{2}"$ . The thickness of double butt-straps (each) not to be less than  $\frac{5}{8}$  the thickness of the plate; single butt-straps not less than  $\frac{9}{8}$ .

Distance from center of rivet to edge of hole = diameter of rivet  $\times 1\frac{1}{2}$ .

Distance between rows of rivets

=  $2 \times$  diam. of rivet or =  $[(\text{diam.} \times 4) + 1] \div 2$ , if chain, and

=  $\frac{\sqrt{[(\text{pitch} \times 11) + (\text{diam.} \times 4)] \times (\text{pitch} + \text{diam.} \times 4)}}{10}$  if zigzag.

Diagonal pitch =  $(\text{pitch} \times 6 + \text{diam.} \times 4) \div 10$ .

*Lloyd's.* — T. S. of rivet bars, 26 to 30 tons; el. not less than 20% in 8". The material must stand bending to a curve, the inner radius of which is



not greater than  $1\frac{1}{2}$  times the thickness of the plate, after having been uniformly heated to a low cherry-red, and quenched in water at  $82^{\circ}$  F.

Rivets in double shear to have only 1.75 times the single section taken in the calculation instead of 2. The shearing strength of rivet steel to be taken at 85% of the T. S. of the material of shell plates. In any case where the strength of the longitudinal joint is satisfactorily shown by experiment to be greater than given by the formula, the actual strength may be taken in the calculation.

### Proportions of Riveted Joints. (Hartford S. B. Insp. and Ins. Co.)

#### Single-riveted Girth Seams of Boilers.

Thickness.	$\frac{1}{4}$		$\frac{5}{16}$		$\frac{3}{8}$		$\frac{7}{16}$		$\frac{1}{2}$	
Diam. rivet-hole.	$\frac{3}{4}$	$\frac{11}{16}$	$\frac{13}{16}$	$\frac{3}{4}$	$\frac{15}{16}$	$\frac{13}{16}$	1	$\frac{15}{16}$	$\frac{11}{16}$	1
Pitch.....	$\frac{21}{16}$	$\frac{21}{16}$	$\frac{21}{8}$	$\frac{21}{8}$	$\frac{23}{8}$	$\frac{21}{8}$	$\frac{27}{16}$	$\frac{23}{8}$	$\frac{21}{2}$	$\frac{21}{2}$
Center to edge..	$\frac{11}{8}$	$\frac{11}{32}$	$\frac{17}{32}$	$\frac{11}{8}$	$\frac{113}{32}$	$\frac{17}{32}$	$\frac{11}{2}$	$\frac{113}{32}$	$\frac{19}{32}$	$\frac{11}{2}$

#### Double-riveted Lap Joints.

Thickness of plate.....	$\frac{1}{4}$	$\frac{5}{16}$	$\frac{3}{8}$	$\frac{7}{16}$	$\frac{1}{2}$
Diam. rivet-hole.....	$\frac{3}{4}$	$\frac{13}{16}$	$\frac{15}{16}$	1	$\frac{11}{16}$
Pitch.....	$\frac{27}{8}$	$\frac{27}{8}$	$\frac{31}{4}$	$\frac{31}{4}$	3.32
Dist. bet. rows.....	$\frac{115}{16}$	$\frac{115}{16}$	$\frac{23}{16}$	$\frac{23}{16}$	2.2
Dist. inner row to edge.....	$\frac{11}{8}$	$\frac{17}{32}$	$\frac{17}{32}$	$\frac{113}{32}$	$\frac{119}{32}$
Efficiency.....	0.74	0.72	0.70	0.70	0.68

#### Triple-riveted Lap Joints.

Thickness.....	$\frac{1}{4}$	$\frac{5}{16}$	$\frac{3}{8}$	$\frac{7}{16}$	$\frac{1}{2}$
Diam. rivet-hole.....	$\frac{11}{16}$	$\frac{3}{4}$	$\frac{13}{16}$	$\frac{15}{16}$	1
Pitch.....	3	$\frac{31}{8}$	$\frac{31}{4}$	$\frac{33}{4}$	$\frac{315}{16}$
Dist. bet. rows.....	2	$\frac{21}{16}$	$\frac{23}{16}$	$\frac{21}{2}$	$\frac{25}{8}$
Inner row to edge.....	$\frac{11}{32}$	$\frac{11}{8}$	$\frac{17}{32}$	$\frac{113}{32}$	$\frac{11}{2}$
Efficiency.....	0.77	0.76	0.75	0.75	0.75

#### Triple-riveted Butt-strap Joints.

Thickness.....	$\frac{5}{16}$	$\frac{3}{8}$	$\frac{7}{16}$	$\frac{1}{2}$	$\frac{9}{16}$	$\frac{5}{8}$
Diam. rivet-hole.....	$\frac{3}{4}$	$\frac{13}{16}$	$\frac{15}{16}$	1	$\frac{11}{16}$	$\frac{11}{16}$
Pitch, inner rows.....	$\frac{31}{8}$	$\frac{31}{4}$	$\frac{33}{8}$	$\frac{33}{4}$	$\frac{37}{8}$	$\frac{37}{8}$
Dist. bet. inner rows.....	$\frac{21}{8}$	$\frac{23}{16}$	$\frac{21}{4}$	$\frac{23}{8}$	$\frac{25}{8}$	$\frac{25}{8}$
Dist. outer to 2d row.....	$\frac{23}{8}$	$\frac{21}{2}$	$\frac{23}{4}$	3	$\frac{33}{16}$	$\frac{33}{16}$
Edge to nearest row.....	$\frac{11}{4}$	$\frac{17}{32}$	$\frac{113}{32}$	$\frac{11}{2}$	$\frac{119}{32}$	$\frac{119}{32}$
Efficiency %.....	88 (?)	87.5	86	86.6	85.4	84 (?)

The distance to the edge of the plate is from the center of rivet-holes.

**Pressure Required to Drive Hot Rivets.** — R. D. Wood & Co. Philadelphia, give the following table (1897):

**POWER TO DRIVE RIVETS HOT.**

Size.	Girder-work.	Tank-work.	Boiler-work.	Size.	Girder-work.	Tank-work.	Boiler-work.
in.	tons.	tons.	tons.	in.	tons.	tons.	tons.
1/2	9	15	20	11/8	38	60	75
5/8	12	18	25	11/4	45	70	100
3/4	15	22	33	11/2	60	85	125
7/8	22	30	45	13/4	75	100	150
1	30	45	60				

The above is based on the rivet passing through only two thicknesses of plate which together exceed the diameter of the rivet but little, if any.

As the plate thickness increases the power required increases approximately in proportion to the square root of the increase of thickness. Thus, if the total thickness of plate is four times the diameter of the rivet, we should require twice the power given above in order to thoroughly fill the rivet-holes and do good work. Double the thickness of plate would increase the necessary power about 40%.

It takes about four or five times as much power to drive rivets cold as to drive them hot. Thus, a machine that will drive 3/4-in. rivets hot will usually drive 3/8-in. rivets cold (steel). Baldwin Locomotive Works drive 1/2-in. soft-iron rivets cold with 15 tons.

**Riveting Pressure Required for Bridge and Boiler Work.**

(Wilfred Lewis, Engineers' Club of Philadelphia, Nov., 1893.)

A number of 3/8-inch rivets were subjected to pressures between 10,000 and 60,000 lbs. At 10,000 lbs. the rivet swelled and filled the hole without forming a head. At 20,000 lbs. the head was formed and the plates were slightly pinched. At 30,000 lbs. the rivet was well set. At 40,000 lbs. the metal in the plate surrounding the rivet began to stretch, and the stretching became more and more apparent as the pressure was increased to 50,000 and 60,000 lbs. From these experiments the conclusion might be drawn that the pressure required for cold riveting was about 300,000 lbs. per square inch of rivet section. In hot riveting, until recently there was never any call for a pressure exceeding 60,000 lbs., but now pressures as high as 150,000 lbs. are not uncommon, and even 300,000 lbs. have been contemplated as desirable.

**Pressure Required for Heading Cold Rivets.** — Experiments made by the author in 1906 on 1/2 and 5/8 in. soft steel rivets showed that the pressure required to head a rivet cold, with a hemispherical heading die, was a function of the final or maximum diameter of the head. The metal began to flow and fill the hole at about 50,000 lbs. per sq. in. pressure, but it hardened and increased its resistance as it flowed until it reached a maximum of about 100,000 lbs. per sq. in. of the maximum area of the head.

**Chemical and Physical Tests of Soft Steel Rivets.** — Ten rivet bars and ten rivets selected from stock of the Champion Rivet Co., Cleveland, O., were analyzed by Oscar Textor, with results as follows:

P. 0.008 to 0.027, av. 0.015; Mn, 0.31 to 0.69, av. 0.46; S, 0.023 to 0.044, av. 0.033; Si, 0.001 to 0.008, av. 0.005; C, 0.06 to 0.19, av. 0.11. Only four of the 20 samples were over 0.14 C. and these were made for high strength. Ten bars and two rivets gave tensile strength, 46,735 to 55,380, av. 52,195 lbs. per sq. in.; elastic limit, 31,350 to 43,150, av. 35,954; elongation, bars only, 28 to 35, av. 31.9% in 8 ins.; reduction of area, 65.6%. Eight bars in single shear gave shearing strength 35,660 to 50,190, av. 44,478 lbs. per sq. in.; seven bars in double shear gave 39,170 to 53,900, av. 45,720 lbs. The shearing strength averaged 86.3% of the tensile strength.

## IRON AND STEEL.

## CLASSIFICATION OF IRON AND STEEL.

(W. Kent, *Railroad and Engineering Journal*, April, 1887.)

Generic Term.	Or obtained from a fluid mass.		Or welded from a pasty mass.
	<i>Non-malleable.</i>	<i>Cast, Malleable.</i>	
How Obtained.			<i>Wrought,</i>
Distinguishing Quality.			Will Not Harden.
Species.	CAST IRON.		(7) WROUGHT IRON.
	(1) Ordinary castings.	(2) Malleable cast iron obtained from No. 1 by annealing in oxides.	(8) WROUGHT STEEL.
Varieties.	CAST STEEL.		Obtained by direct or indirect process, as German, shear, blister, and puddled steels.
	(3) Crucible, (4) Bessemer, and (5) Open-hearth steels.	(6) Mitis.*	

\* No. 6. Mitis is the name given to a new product (having the same general properties and produced by the same processes as soft cast steels) made by adding an alloy of aluminum to melted wrought iron or soft steel before pouring.

† No. 8. Wrought steel is almost an obsolete product, having been replaced in commerce by cast steel. Blister steel, however, is still made as an intermediate product for remelting in the crucible.

Sub-varieties of Nos. 3, 4, and 5, soft, mild, medium, and hard steels, according to percentage of carbon, the divisions between them not being well defined.

Cast iron usually contains over 3% of carbon; cast steel anywhere from 0.06% to 1.50%, according to the purpose for which it is used; wrought iron from 0.02% to 0.10%. The quality of hardening and tempering which formerly distinguished steel from wrought iron is now no longer the dividing line between them, since soft steels are now produced which, by the ordinary blacksmith's tests, will not harden. All products of the crucible, Bessemer, and open-hearth processes are now commercially known as steel.



## CAST IRON.

**The Manufacture of Cast Iron.** — Pig iron is the name given to the crude form of iron as it is produced in the blast furnace. This furnace is a tall shaft, lined with fire brick, often as large as 100 ft. high and 20 ft. in diameter at its widest part, called the "bosh." The furnace is kept filled with alternate layers of fuel (coke, anthracite or charcoal), while a melting temperature is maintained at the bottom by a strong blast. The iron ore as it travels down the furnace is decarbonized by the carbon monoxide gas produced by the incomplete combustion of the fuel, and as it travels farther, into a zone of higher temperature, it absorbs carbon and silicon. The phosphorus originally in the ore remains in the iron. The sulphur present in the ore and in the fuel may go into combination with the lime in the slag, or into the iron, depending on the constitution of the slag and on the temperature. The silica and alumina in the ore unite with the lime to form a fusible slag, which rests on the melted iron in the hearth. The iron is tapped from the furnace several times a day, while in large furnaces the slag is usually run off continuously.

**Grading of Pig Iron.** — Pig iron is approximately graded according to its fracture, the number of grades varying in different districts. In Eastern Pennsylvania the principal grades recognized are known as No. 1 and 2 foundry, gray forge or No. 3, mottled or No. 4, and white or No. 5. Intermediate grades are sometimes made, as No. 2 X, between No. 1 and No. 2, and special names are given to irons more highly silicized than No. 1, as No. 1 X, silver-gray, and soft. Charcoal foundry pig iron is graded by numbers 1 to 5, but the quality is very different from the corresponding numbers in anthracite and coke pig. Southern coke pig iron is graded into ten or more grades. Grading by fracture is a fairly satisfactory method of grading irons made from uniform ore mixtures and fuel, but is unreliable as a means of determining quality of irons produced in different sections or from different ores. Grading by chemical analysis, in the latter case, is the only satisfactory method. The following analyses of the five standard grades of northern foundry and mill pig irons are given by J. M. Hartman (*Bull. I. & S. A.*, Feb., 1892):

	No. 1.	No. 2.	No. 3.	No. 4.	No. 4 B.	No. 5.
Iron.....	92.37	92.31	94.66	94.48	94.08	94.68
Graphitic carbon.....	3.52	2.99	2.50	2.02	2.02	.....
Combined carbon.....	0.13	0.37	1.52	1.98	1.43	5.83
Silicon.....	2.44	2.52	0.72	0.56	0.92	0.41
Phosphorus.....	1.25	1.08	0.26	0.19	0.04	0.04
Sulphur.....	0.02	0.02	trace	0.08	0.04	0.02
Manganese.....	0.28	0.72	0.34	0.67	2.02	0.98

## CHARACTERISTICS OF THESE IRONS.

**No. 1. Gray.** — A large, dark, open-grain iron, softest of all the numbers and used exclusively in the foundry. Tensile strength low. Elastic limit low. Fracture rough. Turns soft and tough.

**No. 2. Gray.** — A mixed large and small dark grain, harder than No. 1 iron, and used exclusively in the foundry. Tensile strength and elastic limit higher than No. 1. Fracture less rough than No. 1. Turns harder, less tough, and more brittle than No. 1.

**No. 3. Gray.** — Small, gray, close grain, harder than No. 2 iron, used either in the rolling-mill or foundry. Tensile strength and elastic limit higher than No. 2. Turns hard, less tough, and more brittle than No. 2.

**No. 4. Mottled.** — White background, dotted closely with small black spots of graphitic carbon; little or no grain. Used exclusively in the rolling-mill. Tensile strength and elastic limit lower than No. 3. Turns with difficulty; less tough and more brittle than No. 3. The manganese in the B pig iron replaces part of the combined carbon, making the iron harder and closing the grain. Notwithstanding the lower combined carbon,

No. 5. *White*. — Smooth, white fracture, no grain, used exclusively in the rolling mill. Tensile strength and elastic limit much lower than No. 4. Too hard to turn and more brittle than No. 4.

Southern pig irons are graded as follows, beginning with the highest in silicon: Nos. 1 and 2 silvery, Nos. 1 and 2 soft, all containing over 3% of silicon; Nos. 1, 2, and 3 foundry, respectively about 2.75%, 2.5% and 2% silicon; No. 1 mill, or "foundry forge;" No. 2 mill, or gray forge; mottled; white.

**Chemistry of Cast Iron.** — Abbreviations, TC, total carbon; GC, graphitic carbon; CC, combined carbon. Numerous researches have been made and many papers written, especially between the years 1895 and 1908, on the relation of the physical properties to the chemical constitution of cast iron. Much remains to be learned on the subject, but the following is a brief summary of prevailing opinions.

**CARBON.** — Carbon exists in three states in cast iron: 1, Combined carbon, which has the property of making iron white and hard; 2, Graphitic carbon or graphite, which is not alloyed with the iron, but exists in it as a separate body, since it may be removed from the fractured surface of pig iron by a brush; 3, a third form, called by Ledebur "tempering graphite carbon," into which combined carbon may be changed by prolonged heating. The relative percentages in which GC and CC may be found in cast iron differ with the rate of cooling from the liquid state, so that in a large casting, cooled slowly, nearly all the C may be GC, while in a small casting from the same ladle cooled quickly, it may be nearly all CC. The total C in cast iron usually is between 3 and 4%.

**COMBINED CARBON.** — CC increases hardness, brittleness and shrinkage. Up to about 1% it increases strength, then decreases it. The presence of S tends to increase the CC in a casting, while Si tends to change CC to GC.

**GRAPHITE.** — GC in a casting causes softness and weakness when above 3%; softness and strength when added to irons low in GC and over 1% in CC. It increases with the size of the casting, with slow cooling, or rather with holding a long time in the mold at a high temperature.

**SILICON.** — Si acts as a softener by counteracting the hardening effect of S, and by changing CC into GC, changes white iron to gray, increases fluidity and lessens shrinkage. When added to hard brittle iron, high in CC, it may increase strength by removing hard brittleness, but when it reduces the CC to 1% and less it weakens the iron. Above 3.5 or 4% it changes the fracture to silvery gray, and the iron becomes brittle and weak. The softening effect of Si is modified by S and Mn.

**SULPHUR.** — S causes the C to take the form of CC, increases hardness, brittleness, and shrinkage, and also has a weakening effect of its own. Above about 0.1% it makes iron very weak and brittle. When Si is below 1%, even 0.06 S makes the iron dangerously brittle.

**MANGANESE.** — Mn in small amount, less than 0.5%, counteracts the hardening influence of S; in larger amounts it changes GC into CC, and acts as a hardener. Above 2% it makes the iron very hard. Mn combines with iron in almost all proportions. When it is from 10 to 30% the alloy is called spiegeleisen, from the German word for mirror, and has large, bright crystalline faces. Above 50% it is known as ferro-manganese. Mn has the property of increasing the solubility of iron for carbon; ordinary pig iron containing rarely over 4.2% C, while spiegeleisen may have 5%, and ferro-manganese as high as 6%. Cast iron with 1% Mn is used in making chilled rolls, in which a hard chill is desired. When softness is required in castings, Mn over 0.4% has to be avoided. Mn increases shrinkage. It also decreases the magnetism of iron. Iron with 25% Mn loses all its magnetism. It therefore has to be avoided in castings for dynamo fields and other pieces of electrical machinery.

**PHOSPHORUS.** — P increases fluidity, and is therefore valuable for thin and ornamental castings in which strength is not needed. It increases softness and decreases shrinkage. Below 0.7% it does not appear to decrease strength, but above 1% it is a weakener.

**COPPER.** — Cu is found in pig irons made from ores containing Cu. From 0.1 to 1% it closes the grain of cast iron, but does not appreciably cause brittleness.

**ALUMINUM.**—Al from 0.2 to 1.0% (added to the ladle in the form of a FeAl alloy) increases the softness and strength of white iron; added to gray iron it softens and weakens it. Where loss is occasioned by defective castings, or where iron does not flow well, the addition of Al will give sounder, closer grained castings. In proportions of 2% and over Al will decrease the shrinkage of cast iron.

**TITANIUM.**—An addition of 2 to 3% of a TiFe alloy containing 10% Ti caused an increase of 20 to 30% in strength of cast iron. A. J. Rossi, *A.I.M.E.*, xxxiii, 194. Ti reacts with any O or N present in the metal and thus purifies it, and does not remain in the metal. After enough Ti for deoxidation has been added, further additions have no effect. R. Moldenke, *A.I.M.E.*, xxxv, 153.

**VANADIUM.**—Va to the extent of 0.15% added to the ladle in the form of a ground FeVa alloy greatly increases the strength of cast iron. It acts as a deoxidizer and also by alloying.

**OXIDE OF IRON.**—The cause of the difference in strength of charcoal and coke irons of identical composition is believed by Dr. Moldenke (*A.I.M.E.*, xxxi, 988) to be the degree of oxidation to which they have been subjected in making or remelting. Since Mn, Ti, and Va all act as deoxidizers, it should be possible by additions to the ladle of alloys of FeMn, FeVa, or FeTi, to make the two irons of equal strength.

**Temper Carbon.** The main part of the C in white cast iron is the carbide  $Fe_3C$ . This breaks down under annealing to what Ledebur calls "temper carbon," and in annealing in oxides, as in making malleable iron, it is oxidized to CO. The C remaining in the casting at the end of the process is nearly all GC, since the latter is very slowly oxidized.

**Influence of Various Elements on Cast Iron.**—W. S. Anderson, *Castings*, Sept., 1908, gives the following:

Fluidity, increased by	Si, P, G.C.	Reduced by S, C.C.
Shrinkage, increased by	S, Mn, C.C.	Reduced by Si, P, G.C.
Strength, increased by	Mn, C.C.	Reduced by Si, S, P, G.C.
Hardness, increased by	S, Mn, C.C.	Reduced by Si, G.C.
Chill, increased by	S, Mn, C.C.	Reduced by Si, P, G.C.

**Microscopic Constituents.** (See also Metallography, under Steel.)

**Ferrite**, iron free from carbon. It is found in mild steel in small amounts in gray cast iron, and in malleable cast iron.

**Cementite**,  $Fe_3C$ . Fe with 6.67% C. Harder than hardened steel. Hardness U on the mineralogical scale. Found in high C steel, and in white and mottled pig.

**Pearlite**, a compound made up of alternate laminae of ferrite and cementite, in the ratio of 7 ferrite to 1 cementite, and containing therefore 0.83% C. Found in iron and steel cooled very slowly from a high temperature. In steel of 0.83 C it composes the entire mass. Steels lower or higher than 0.83 C contain pearlite mixed with ferrite or with cementite.

**Martensite**, the hardening component of steel. Found in iron and steel quenched above the recalescence point, and in tempered steel. It forms the entire structure of 0.83 C steel quenched.

**Analyses of Cast Iron.** (Notes of the table on page 440.)

1 to 7. R. Moldenke, Pittsbg. F'drymen's Assn., 1898; 1 to 5, pig irons; 6, white iron cast in chills; 7, gray iron cast in sand from the same ladle. The temperatures were taken with a Le Chatelier pyrometer. For comparison, steel, 1.18 C, melted at 2450° F.; silico-spiegel, 12.30 Si, 16.98 Mn, at 2190°; ferro-silicon, 12.01 Si, 2.17 CC, at 2040°; ferro-tungsten, 39.02 W, at 2280°; ferro-manganese, 81.4 Mn, at 2255°; ferro-chrome, 62.7 Cr, at 2400°; ditto, 5.4 Cr., at 2180°.

8. Gray foundry Swedish pig, very strong. 9. Pig to be used in mixtures of gray pig and scrap, for castings requiring a hard close grain, machining to a fine surface, and resisting wear. 8 to 15, from paper by F. M. Thomas, *Castings*, July, 1908.

16. Specification by J. E. Johnston, Jr., *Am. Mach.*, Oct. 15, 1903. The results were excellent. Si might have been 0.75 to 1.25 if S had been kept below 0.035.

17 to 22. G. R. Henderson, *Trans. A.S.M.E.*, vol. xx. The chill is to be measured in a test bar 2 × 2 × 24 in., the chill piece being so placed as to form part of one side of the mold. The actual depth of white iron will be measured.



## Analyses of Cast Iron.

(Abbreviations, TC, total carbon; GC, graphitic carbon; CC, combined carbon.)

No.	TC	GC	CC	Silicon.	Man- ganese.	Phos- phorus.	Sul- phur.	
1	3.98	0.39	3.59	0.38	0.13	0.20	0.038	Melts at 2048° F.
2	3.78	1.76	2.01	0.69	0.44	0.53	0.031	Melts at 2156° F.
3	3.88	2.60	1.28	1.52	0.49	0.45	0.035	Melts at 2211° F.
4	4.03	3.47	0.56	2.01	0.49	0.39	0.034	Melts at 2248° F.
5	3.56	3.43	0.13	2.40	0.90	0.08	0.032	Melts at 2280° F.
6	4.39	0.13	4.26	0.65	0.40	0.25	0.038	Melts at 2000° F.
7	4.45	2.99	1.46	0.67	0.41	0.26	0.039	Melts at 2237° F.
8	3.30	2.80	0.50	2.00	0.60	0.08	0.03	Swedish char- coal pig.
9	....	2.25-2.5	0.6-0.8	0.8-1.2	0.4-0.8	0.15-0.4	.....	For engine cylin- ders.
10	3.40	3.40	trace	2.90	0.50	1.65	0.04	English, high P. No. 1.
11	3.40	3.20	0.20	2.60	0.50	1.58	0.04	English, high P. No. 3.
12	....	3.2-3.6	0.1-0.15	2.5-2.8	up to 1.0	1.3-1.5	.03-.04	For thin orna- mental work.
13	....	3.0-3.2	0.4-0.5	2-2.3	up to 1.0	1-1.3	.06-.08	For medium size castings.
14	....	2.8-3.0	0.4-0.6	1.2-1.5	0.6-0.9	0.4-0.6	.06-.08	Heavy machin- ery castings.
15	....	2.5-2.8	0.6-0.8	1.0-1.3	0.5-0.7	0.4-0.7	.08-.12	Cylinders and hydraulic work.
16	.....	.....	.....	1.2-1.8	0.4-1.0	0.4-0.7	to .06	For hydraulic cylinders.
17	....	2.7-3.0	0.5-0.8	0.5-0.7	0.3-0.5	0.3-0.5	.05-.07	For car wheels.
18	....	2.6-3.1	0.6-1.0	0.6-0.7	0.1-0.3	0.3-0.5	.05-.08	For car wheels.
19	....	2.5-3.0	0.4-0.9	1.3-1.7	0.5-1.0	0.3-0.4	.03 max	Charcoal pig. 1/4 in. chill.
20	....	2.3-2.7	0.5-1.0	1.0-1.5	0.5-1.0	0.3-0.4	.03	" Ditto 1/2 in. chill.
21	....	2.0-2.5	0.8-1.2	0.8-1.2	0.5-1.0	0.3-0.4	.035	" Ditto 3/4 in. chill.
22	....	1.8-2.2	0.9-1.4	0.5-1.0	0.3-0.7	0.3-0.4	.035	" Ditto 1 in. chill.
23	3.87	3.44	0.43	1.67	0.29	0.095	0.032	Series A. Am. F'dmen's Assn.
24	3.82	3.23	0.59	1.95	0.39	0.405	0.042	Series B. ditto.
25	3.84	3.52	0.32	2.04	0.39	0.578	0.044	Series C. ditto.
26	....	2.8-3.2	0.5-0.7	1.3-1.5	0.3-0.6	0.5-0.8	.06-.10	For locomotive cylinders.
27	....	2.3-2.4	0.8-1.0	1.8-2.0	0.8-1.0	0.6-0.8	.06-.10	" Semi-steel."
28	....	2.4-2.6	0.8-1.0	0.9-1.0	0.6-0.7	0.1-0.3	.04-.06	" Semi-steel."
29	4.33	3.08	1.25	0.73	0.44	0.43	0.08	A strong car wheel, Cu, 0.03.
30	3.17	2.72	0.45	1.99	0.39	0.65	0.13	Automobile cyl- inders.
31	3.34	2.57	0.77	1.89	0.39	0.70	0.09	Ditto.
32	3.5	2.9	0.6	0.7	0.4	0.5	0.08	Good car wheel.
33	3.55	3.0	0.55	2.75	2.39	0.86	0.014	Scotch irons.
34	.....	.....	.....	3.10	1.80	0.90	.....	" Am. Scotch " Ohio irons.
35	.....	.....	.....	0.75-1.5	to 0.6	to 0.22	to 0.04	Pig for malle- able castings.
36	.....	.....	.....	2-25	to 0.7	to 0.7	to 0.15	Brake-shoes.
37	.....	.....	.....	1.2-1.5	0.5-0.8	0.35-0.6	to 0.09	Hard iron for heavy work.
38	.....	.....	.....	1.5-2	0.5-0.8	0.35-0.6	to 0.08	Medium iron for general work.
39	.....	.....	.....	2.2-2.8	to 0.7	to 0.7	to 0.085	Soft iron cast'gs

23 to 25. Series of bars tested by a committee of the association. See results of tests on page 419. Series A, soft Bessemer mixture; B, dynamo-frame iron; C, light machinery iron. Samples for analysis were taken from the 1-in. square dry sand bars.

26. Specifications by a committee of the Am. Ry. Mast. Mechs. Assn., 1906. T.S., 25,000; transverse test, 3000 lb. on 1 $\frac{1}{4}$ -in. round bar, 12 in. between supports; deflection, 0.1 in. minimum; shrinkage,  $\frac{1}{8}$  in. max. 27, soft "semi-steel;" 28, harder do. They approach air-furnace iron in most respects, and excel it in strength; test bars 2 X 1 X 24 in. of the low Si semi-steel showing 2800 to 3000 lb. transverse strength, with  $\frac{7}{16}$  in. deflection. M. B. Smith, *Eng. Digest*, Aug., 1908. 29. J. M. Hartman, *Bull. I. & S. Assn.*, Feb., 1892. The chill was very hard,  $\frac{1}{4}$  in. deep at root of flange,  $\frac{1}{2}$  in. deep on tread. 30, 31. Strong and shock-resisting. T.S., 38,000. *Castings*, June, 1908. 32. Com. of A.S.T.M., 1905, *Proc.*, v. 65. Successful wheels varying quite considerably from these figures may be made. 33, 34. C. A. Meissner, *Iron Age*, 1890. Average of several. 35. R. Moldenke, *A.S.M.E.*, 1908. 36-39. J. W. Keep, *A.S.M.E.*, 1907.

A *Chilling Iron* is one which when cooled slowly has a gray fracture, but when cast in a mold one side of which is a thick mass of cast-iron, called a chill, the fractured surface shows white iron for some depth on the side that was rapidly cooled by the chill. See Table Nos. 19-22.

**Specifications for Castings**, recommended by a committee of the A.S.T.M., 1908. S in gray iron castings, light, not over 0.08; medium, not over 0.10; heavy, not over 0.12. A light casting is one having no section over  $\frac{1}{2}$  in. thick, a heavy casting one having no section less than 2 in. thick, and a medium casting one not included in the classification of light or heavy. The transverse strength of the arbitration bar shall not be under 2500 lb. for light, 2900 lb. for medium, and 3300 lb. for heavy castings; in no case shall the deflection be under 0.10 in. When a tensile test is specified this shall run not less than 18,000 lb. per sq. in. for light, 21,000 lb. for medium, and 24,000 lb. for heavy castings.

The "arbitration bar" is 1 $\frac{1}{4}$  in. diam., 15 in. long, cast in a thoroughly dried and cold sand mold. The transverse test is made with supports 12 in. apart. The moduli of rupture corresponding to the figures for transverse strength are respectively 39115, 45373, and 51632, being the product of the figures given and the constant 15.646, the factor for  $R/P$  for a 1 $\frac{1}{4}$ -in. round bar 12 in. between supports.\* The standard form of tensile test piece is 0.8 in. diam., 1 in. long between shoulders, with a fillet  $\frac{7}{32}$  in. radius, and ends 1 in. long, 1 $\frac{1}{4}$  in. diam., cut with standard thread, to fit the holders of the testing machine.

Specifications by J. W. Keep, *A.S.M.E.*, 1907. See Table of Analyses, Nos. 37-39, page 417. Transverse test, 1 X 1 X 12-in. bar, hard iron castings. No. 37, 2400 to 2600 lb.; tensile test of same bar, 22,000 to 25,000 lb. No. 38, medium, transverse, 2200 to 2400; tensile, 20,000 to 23,000. No. 39, soft, transverse, 2000 to 2200; tensile, 18,000 to 20,000.

**Specifications for Metal for Cast-iron Pipe.**—*Proc. A.S.T.M.*, 1905, *A.I.M.E.*, xxxv, 166. Specimen bars 2 in. wide X 1 in. thick X 24 in. between supports, loaded in the center, for pipes 12 in. or less in diam. shall support 1900 lb. and show a deflection of not less than 0.30 in. before breaking. For pipes larger than 12 in., 2000 lb. and 0.32 in. The corresponding moduli of rupture are respectively 34,200 and 36,000 lb. Four grades of pig are specified: No. 1, Si, 2.75; S, 0.035. No. 2, Si, 2.25; S, 0.045. No. 3, Si, 1.75; S, 0.055. No. 4, Si, 1.25; S, 0.065. A variation of 10% of the Si either way, and of 0.01 in the S above the standard, is allowed.

**Chemical Standards for Iron Castings.**—The following analyses are tentative standards, or probable best analyses, suggested by the Committee on Standards for Iron Castings, American Foundrymen's Association, June, 1910. "Heavy" castings are those in which no section is less than 2 in. thick; "light" castings are those having any section less than  $\frac{1}{2}$ -in. thick; "medium" castings are those not included in the definition of light and heavy castings. The desirable

\* Formula,  $\frac{1}{4}Pl = RI/c$ ; see page 283.  $I = \frac{1}{64}\pi d^4$ ;  $c = \frac{1}{2}d$ ;  $d = 1\frac{1}{4}$  in.;  $l = 12$  in.  $I = 0.11983$ ;  $R/P = \frac{1}{4} \times 12 \times \frac{1}{8} \div 0.11983 = 15.646$ .

percentage of silicon depends largely on the thickness of the casting and the practice followed in shaking out. These factors, being in many cases undetermined, are allowed for by giving fairly wide limits to this element. The effect of purifying alloys and the use of steel scrap have not been taken into account. In many cases a wide range of composition is compatible with the best results, and in such cases the question of cost will be the first element to be considered.

	Si.	S.	P.	Mn.	C. (Comb.)	C. (Total)
Acid - resisting castings (stills, eggs, etc.) . . . . .	1.00-2.00	0.05-*	0.40-*	1.00-1.50		3.00-3.50
Agricultural machinery, ordinary . . . . .	2.00-2.50	0.06-0.08	0.60-0.80	0.60-0.80		
Agricultural machinery, very thin . . . . .	2.25-2.75	0.06-0.08	0.70-0.90	0.50-0.70		
Annealing boxes, etc. . . . .	1.40-1.60	0.06-	0.20-	0.60-1.00		
Automobile castings . . . . .	1.75-2.25	0.08-	0.40-0.50	0.60-0.80		
Balls for ball mills . . . . .	1.00-1.25	0.08-	0.20-	0.60-1.00		
Boiler castings . . . . .	2.00-2.50	0.06-	0.20-	0.60-1.00		
Car castings, gray iron . . . . .	1.50-2.25	0.08-	0.40-0.60	0.60-1.00		
Chilled castings . . . . .	0.75-1.25	0.08-0.10	0.20-0.40	0.80-1.20		
Chills . . . . .	1.75-2.25	0.07-	0.20-0.40	0.60-1.00		
Crusher jaws . . . . .	0.80-1.00	0.08-0.10	0.20-0.40	0.80-1.20		
Cutting-tools, chilled . . . . .	1.00-1.25	0.08-	0.20-0.40	0.60-0.80		
Cylinders:						
Air and ammonia . . . . .	1.00-1.75	0.09-	0.30-0.50	0.70-0.90		3.00-3.30
Automobile . . . . .	1.75-2.00	0.08-	0.40-0.50	0.60-0.80	0.55-0.65	3.00-3.25
Gas engine . . . . .	1.00-1.75	0.08-	0.20-0.40	0.70-0.90		3.00-3.30
Hydraulic, heavy . . . . .	0.80-1.20	0.10-	0.20-0.40	0.80-1.00		low
Hydraulic, medium . . . . .	1.20-1.60	0.09-	0.30-0.50	0.70-0.90		low
Locomotive . . . . .	1.00-1.50	0.08-0.10	0.30-0.50	0.80-1.00		
Steam engine, heavy . . . . .	1.00-1.25	0.10-	0.20-0.40	0.80-1.00		low
Steam engine, medium . . . . .	1.25-1.75	0.09-	0.30-0.50	0.70-0.90		
Dies, drop-hammer . . . . .	1.25-1.50	0.07-	0.20-	0.60-0.80		low
Diamond polishing wheels† . . . . .	2.70	0.063	0.30	0.44	1.60	2.97
Electrical machinery (frames, bases, spiders), large . . . . .	2.00-2.50	0.08-	0.50-0.80	0.30-0.40	0.20-0.30	low
Electrical machinery, small . . . . .	2.50-3.00	0.08-	0.50-0.80	0.30-0.40	0.20-0.30	low
Engine castings:						
Bedplates . . . . .	1.25-1.75	0.10-	0.30-0.50	0.60-0.80		
Flywheels . . . . .	1.50-2.25	0.08-	0.40-0.60	0.50-0.70		
Do., automobile . . . . .	2.25-2.50	0.07-	0.40-0.50	0.50-0.70		
Frames . . . . .	1.25-2.00	0.09-	0.30-0.50	0.60-1.00		
Pillow blocks . . . . .	1.50-1.75	0.08-	0.40-0.50	0.60-0.80		
Piston rings . . . . .	1.50-2.00	0.08-	0.30-0.50	0.40-0.60		low
Fire pots and furnace castings . . . . .	2.00-2.50	0.06-	0.20-	0.60-1.00		low
Grate bars . . . . .	2.00-2.50	0.06-	0.20-	0.60-1.00	0.30-	low
Grinding machinery, chilled castings for . . . . .	0.50-0.75	0.15-0.20	0.20-0.40	1.50-2.00		
Gun carriages . . . . .	1.00-1.25	0.06-	0.20-0.30	0.80-1.00		low
Gun iron . . . . .	1.00-1.25	0.06-	0.20-0.30		0.80-1.00	low
Hardware (light) and hollow ware . . . . .	2.25-2.75	0.08-	0.50-0.80	0.50-0.70		
Heat resistant iron (re- torts) . . . . .	1.25-2.50	0.06-	0.20-	0.60-1.00	0.30-	low
Ingot molds and stools . . . . .	1.25-1.50	0.06-	0.20-	0.60-1.00		
Locomotive castings, heavy . . . . .	1.25-1.50	0.08-	0.30-0.50	0.70-0.90		

\* Affixed hyphens indicate that the percentages present should be under those given.



	Si.	S.	P.	Mn.	C. (Comb.)	C. (Total)
Loco. Castings, light....	1.50-2.00	0.08*	0.40-0.60	0.60-0.80	.....	.....
Machinery castings, heavy.....	1.00-1.50	0.10-	0.30-0.50	0.80-1.00	.....	low
Do., medium.....	1.50-2.00	0.09-	0.40-0.60	0.60-0.80	.....	.....
Do., light.....	2.00-2.50	0.08-	0.50-0.70	0.50-0.70	.....	.....
Friction clutches.....	1.75-2.00	0.08-0.10	0.30-	0.50-0.70	.....	low
Gears, heavy.....	1.00-1.50	0.08-0.10	0.30-0.50	0.80-1.00	.....	low
Do., medium.....	1.50-2.00	0.09-	0.40-0.60	0.70-0.90	.....	.....
Do., small.....	2.00-2.50	0.08-	0.50-0.70	0.60-0.80	.....	.....
Pulleys, heavy.....	1.75-2.25	0.09-	0.50-0.70	0.60-0.80	.....	.....
Do., light.....	2.25-2.75	0.08-	0.60-0.80	0.50-0.70	.....	.....
Shaft collars and couplings.....	1.75-2.00	0.08-	0.40-0.50	0.60-0.80	.....	.....
Shaft hangers.....	1.50-2.00	0.08-	0.40-0.50	0.60-0.80	.....	.....
Ornamental work.....	2.25-2.75	0.08-	0.60-1.00	0.50-0.70	.....	.....
Permanent molds.....	2.00-2.25	0.07-	0.20-0.40	0.60-1.00	.....	.....
Permanent mold castings.	1.50-3.00	0.06-	.....	0.40-	.....	.....
Piano plates.....	2.00-2.25	0.07-	0.40-0.60	0.60-0.80	.....	.....
Pipe.....	1.50-2.00	0.10-	0.50-0.80	0.60-0.80	.....	.....
Pipe fittings.....	1.75-2.50	0.08-	0.50-0.80	0.60-0.80	.....	.....
Do., for superheated steam lines.....	1.50-1.75	0.08-	0.20-0.40	0.70-0.90	.....	low
Plow points, chilled.....	0.75-1.25	0.08-	0.20-0.30	0.80-1.00	.....	.....
Propeller wheels.....	1.00-1.75	0.10-	0.20-0.40	0.60-1.00	.....	low
Pumps, hand.....	2.00-2.25	0.08-	0.60-0.80	0.50-0.70	.....	.....
Radiators.....	2.00-2.25	0.08-	0.60-0.80	0.50-0.70	0.50-0.60	.....
Railroad castings.....	1.50-2.25	0.08-	0.40-0.60	0.60-0.80	.....	.....
Rolling mill machinery: Housings.....	1.00-1.25	0.08-	0.20-0.30	0.80-1.00	.....	low
Rolls, chilled.....	0.60-0.80	0.06-0.08	0.20-0.40	1.00-1.20	.....	3.00-3.25
Rolls, unchilled (sand- cast)†.....	0.75	0.03	0.25	0.66	1.20	4.10
Scales.....	2.00-2.30	0.08-	0.60-1.00	0.50-0.70	.....	.....
Slag car castings.....	1.75-2.00	0.07-	0.30-	0.70-0.90	.....	.....
Soil pipe and fittings.....	1.75-2.25	0.09-	0.50-0.80	0.60-0.80	.....	.....
Stove plate.....	2.25-2.75	0.08-	0.60-0.90	0.60-0.80	.....	.....
Valves, large.....	1.25-1.75	0.09-	0.20-0.40	0.80-1.00	.....	.....
Do., small.....	1.75-2.25	0.08-	0.30-0.50	0.60-0.80	.....	low
Water heaters.....	2.00-2.25	0.08-	0.30-0.50	0.60-0.80	.....	.....
Wheels, large.....	1.50-2.00	0.09-	0.30-0.40	0.60-0.80	.....	.....
Do., small.....	1.75-2.00	0.08-	0.40-0.50	0.50-0.70	.....	.....
White iron castings†.....	0.50-0.90	0.15-0.25	0.20-0.70	0.17-0.50	2.90	2.50

\* Affixed hyphens indicate that the percentages present should be under those given.

† But one or two analyses available—no suggestion made.

### Standard Specifications for Foundry Pig Iron.

(American Foundrymen's Association, May, 1909.)

**ANALYSIS.**—It is recommended that foundry pig be bought by analysis.

**SAMPLING.**—Each carload or its equivalent shall be considered as a unit. One pig of machine-cast, or one-half pig of sand-cast iron shall be taken to every four tons in the car, and shall be so chosen from different parts of the car as to represent as nearly as possible the average quality of the iron. Drillings shall be taken so as to fairly represent the composition of the pig as cast. An equal quantity of the drillings from each pig shall be thoroughly mixed to make up the sample for analysis.

**PERCENTAGE OF ELEMENTS.**—When the elements are specified the following percentages and variations shall be used. Opposite each percentage of the different elements a syllable has been affixed so that buyers, by combining these syllables, can form a code word to be used in telegraphing.

SILICON		SULPHUR		TOTAL CARBON		MANGANESE		PHOSPHORUS	
%	Code	(max.)	Code	(min.)	Code	%	Code	%	Code
1.00	La	0.04	Sa	3.00	Ca	0.20	Ma	0.20	Pa
1.50	Le	0.05	Se	3.20	Ce	0.40	Me	0.40	Pe
2.00	Li	0.06	Si	3.40	Ci	0.60	Mi	0.60	Pi
2.50	Lo	0.07	So	3.60	Co	0.80	Mo	0.80	Po
3.00	Lu	0.08	Su	3.80	Cu	1.00	Mu	1.00	Pu
		0.09	Sy			1.25	My	1.25	Py
		0.10	Sh			1.50	Mh	1.50	Ph

Percentages of any element specified one-half way between the above shall be designated by the addition of the letter *x* to the next lower symbol, thus Lex means 1.75 Si.

Allowed variation: Si, 0.25; P, 0.20; Mn, 0.20. The percentages of P and Mn may be used as maximum or minimum figures when so specified.

Example: — Le-sa-pi-me represents 1.50 Si, 0.04 S, 0.60 P, 0.40 Mn.

BASE OR QUOTING PRICE.—For market quotations an iron of 2.00 Si (with variation 0.25 either way) and S 0.05 (max.) shall be taken as the base. The following table may be filled out, and become a part of a contract; "B," or Base, represents the price agreed upon for a pig of 2.00 Si and under 0.05 S. "C" is a constant differential to be determined at the time the contract is made.

Sulphur	Silicon									
	3.25	3.00	2.75	2.50	2.25	2.00	1.75	1.50	1.25	1.00
0.04	B+6C	B+5C	B+4C	B+3C	B+2C	B+C	B	B-1C	B-2C	B-3C
0.05	B+5C	B+4C	B+3C	B+2C	B+1C	B	B-1C	B-2C	B-3C	B-4C
0.06	B+4C	B+3C	B+2C	B+1C	B	B	B-1C	B-2C	B-3C	B-4C
0.07	B+3C	B+2C	B+1C	B	B	B-1C	B-2C	B-3C	B-4C	B-5C
0.08	B+2C	B+1C	B	B	B-1C	B-2C	B-3C	B-4C	B-5C	B-6C
0.09	B+1C	B	B-1C	B-2C	B-3C	B-4C	B-5C	B-6C	B-7C	B-8C
0.10	B	B-1C	B-2C	B-3C	B-4C	B-5C	B-6C	B-7C	B-8C	B-9C

**Tensile Tests of Cast-iron Bars.**

(American Foundrymen's Association, 1899.)

Size, in...	Square Bars.				Round Bars.			
	0.5x0.5	1x1	1.5x1.5	2x2	0.56	1.13	1.69	2.15
(A) g. c. . . . .	15,900	13,900	12,100	10,600	16,000	13,800	12,000	11,000
" g. m. . . . .	15,900	15,400	12,900	10,900	14,300	13,800	13,500	12,200
" d. s. . . . .	14,600	12,900	12,300	9,800	14,300	13,700	11,700	10,500
" d. m. . . . .	14,600	13,800	13,400	12,100	14,300	13,600	13,200	10,600
(B) g. c. . . . .	17,100	15,200	12,900	11,500	16,500	15,900	13,100	11,400
" g. m. . . . .	17,100	17,600	15,000	11,800	16,500	19,000	15,400	12,500
" d. c. . . . .	16,300	15,100	13,300	11,100	16,700	16,200	13,200	11,000
" d. m. . . . .	16,300	18,400	15,000	12,100	16,700	16,900	15,100	13,100
(C) g. c. . . . .	17,700	16,000	12,500	11,100	17,800	15,900	14,200	12,000
" g. m. . . . .	17,700	18,500	15,100	11,700	17,800	17,400	15,000	11,600
" d. c. . . . .	16,400	16,000	12,200	11,300	16,400	15,900	14,000	11,600
" d. m. . . . .	16,400	17,100	14,100	9,800	16,400	17,700	15,900	10,400
av. g. . . . .	13,600	16,100	13,400	11,300	13,400	16,000	13,900	11,600
av. d. . . . .	15,800	15,500	13,400	11,000	15,800	15,700	13,800	11,200
av. c. . . . .	14,700	14,800	12,500	10,900	16,300	15,200	13,000	11,200
av. m. . . . .	14,700	16,800	14,200	11,400	16,400	16,400	14,600	11,700

**Compression Tests of Cast-iron Bars.**

Size, in...	0.5x0.5	1x1	1.5x1.5	2x2	2.5x2.5	3x3	3.5x3.5	4x4
(A) (1) . . . . .	29,570	20,010	17,180	13,810	10,950	9,830	9,350	9,100
" (2) . . . . .	29,570	21,990	17,920	13,750	12,040	11,200	10,770	10,340
" (3) . . . . .	29,570	21,990	17,180	13,880	11,430	10,270	9,830	9,950
" (4) . . . . .	29,570	21,990	17,180	13,880	10,950	10,430	9,540	9,570
(B) (1) . . . . .	38,360	23,000	20,980	18,130	15,060	13,790	13,160	12,430
" (2) . . . . .	38,360	12,440	24,820	21,640	18,270	17,000	15,970	16,140
" (3) . . . . .	38,360	12,440	20,980	18,740	15,940	14,410	15,200	13,950
" (4) . . . . .	38,360	12,440	20,980	18,740	15,940	13,900	13,560	13,760
(C) (1) . . . . .	38,360	24,890	20,750	18,010	17,840	15,950	15,880	14,220
" (2) . . . . .	38,360	27,900	22,060	21,750	19,800	18,170	17,100	16,410
" (3) . . . . .	38,360	27,900	20,750	19,340	18,050	16,850	16,510	15,250
" (4) . . . . .	38,360	27,900	20,750	17,840	18,050	16,040	16,080	14,880

Transverse Tests of Cast-Iron Bars. Modulus of Rupture.

Size *	0.5×0.5	1×1	1.5×1.5	2×2	2.5×2.5	3×3	3.5×3.5	4×4
Diam. †	0.56	1.13	1.69	2.15	2.82	3.38	3.95	4.51
(A) r. d. c.	31,100	33,400	33,900	31,700	27,000	26,600	23,400	22,600
" r. d. m.		27,800	38,000	32,300	28,000	28,600	22,400	22,900
(B) s. g. c.	44,400	39,100	39,500	33,900	31,900	29,700	27,200	27,600
" s. g. m.		37,400	40,300	34,700	35,800	33,500	30,100	27,100
" s. d. c.	35,500	38,300	34,000	32,900	31,900	30,200	29,300	25,900
" s. d. m.		30,200	36,200	33,300	35,200	30,900	28,100	25,800
" r. g. c.	36,400	46,200	41,200	41,400	41,300	36,300	34,800	31,000
" r. g. m.		40,000	44,800	38,800	37,100	32,900	32,700	32,300
" r. d. c.	37,800	49,000	44,300	39,200	40,700	31,800	35,300	31,100
" r. d. m.		39,100	37,800	37,700	33,900	32,800	32,000	31,200
(C) s. g. c.	51,800	39,200	33,600	37,900	32,200	31,100	31,300	29,200
" s. g. m.			40,200	37,000	33,700	33,300	32,300	27,900
" s. d. c.	48,000	39,100	38,800	35,100	31,200	29,300	29,300	27,800
" s. d. m.			38,900	35,400	33,500	32,700	29,100	25,500
" r. g. c.	62,800	48,500	39,000	44,500	41,400	41,200	35,000	32,300
" r. g. m.		55,700	49,200	42,900	41,500	36,500	34,100	36,000
" r. d. c.	53,000	50,400	44,000	40,200	39,500	37,800	35,200	32,100
" r. d. m.		47,900	51,300	38,000	38,900	36,300	32,200	33,500
Av. (B) s.	39,900	36,200	37,500	33,700	33,700	31,100	28,700	26,600
" (B) r.	37,100	43,600	42,000	39,300	38,200	33,400	33,700	31,400
" (C) s.	49,900	39,100	37,900	36,300	32,600	31,600	30,500	27,600
" (C) r.	57,900	50,600	45,900	41,400	40,400	37,900	34,100	33,200
" (B) & (C) g.	48,800	43,100	41,000	38,800	36,800	33,900	32,200	30,400
" (B) & (C) d.	43,300	41,600	40,700	36,500	35,600	32,700	31,300	30,400
Gen'l av.	46,100	42,400	40,800	37,700	36,200	33,400	31,700	29,900
Equiv. load.	320	2356	7650	16,756	31,424	50,100	75,516	106,311

\* Size of square bars as cast. in. † Diam. of round bars as cast. in.

NOTES ON THE TABLES OF TESTS.—The machined bars were cut to the next size smaller than the size they were cast. The transverse bars were 12 in. long between supports. (A), (B), (C), three qualities of iron; for analyses see page 417; r, round bars; s, square bars; d, cast in dry sand; g, cast in green sand; c, bar tested as cast; m, bar machined to size. The general average (next to last line of the first table) is the average of the six lines preceding. The equivalent load (last line) is the calculated total load that would break a square bar whose modulus of rupture is that of the general average.

COMPRESSION TESTS.—The figures given are the crushing strengths, in pounds, of ½ in. cubes cut from the bars. Multiply by 4 to obtain lbs. per sq. in. (1) Cube cut from the middle of the bar; (2) first ½ in. from edge; (3) second ½ in. from edge; (4) third ½ in. from edge.

Some Tests of Cast Iron. (G. Lanza, *Trans. A.S.M.E.*, x, 187.)—The chemical analyses were as follows: Gun iron: TC, 3.51; GC, 2.80; S, 0.133; P, 0.155; Si, 1.140. Common iron: S, 0.173; P, 0.413; Si, 1.89.

The test specimens were 26 in. long; those tested with the skin on being very nearly 1 in. square, and those tested with the skin removed being cast nearly 1¼ in. square, and afterwards planed down to 1 in. square.

Tensile Elastic Modulus  
Strength. Limit. of

	T.S.	Av.	Elasticity.
Unplaned common..	20,200 to 23,000	= 22,066	6,500 13,194,233
Planed common....	20,300 to 20,800	" " = 20,520	5,833 11,943,953
Unplaned gun.....	27,000 to 28,775	" " = 28,175	11,000 16,130,300
Planed gun.....	29,500 to 31,000	" " = 30,500	8,500 15,932,880

The elastic limit is not clearly defined in cast iron, the elongations increasing faster than the increase of the loads from the beginning of the test. The modulus of elasticity is therefore variable, decreasing as the loads increase.

The Strength of Cast Iron depends on many other things besides its chemical composition. Among them are the size and shape of the casting, the temperature at which the metal is poured, and the rapidity of cooling. Internal stresses are apt to be induced by rapid cooling, and slow cooling tends to cause segregation of the chemical constituents and



opening of the grain of the metal, making it weak. The author recommends that in making experiments on the strength of cast iron, bars of several different sizes, such as  $\frac{1}{2}$ , 1,  $1\frac{1}{2}$ , and 2 in. square (or round), should be taken, and the results compared. Tests of bars of one size only do not furnish a satisfactory criterion of the quality of the iron of which they are made. *Trans. A.I.M.E.*, xxvi, 1017.

**Theory of the Relation of Strength to Chemical Constitution.** — J. E. Johnston, Jr. (*Am. Mach.*, April 5 and 12, 1900), and H. M. Howe (*Trans. A.I.M.E.*, 1901) have presented a theory to explain the variation in strength of cast iron with the variation in combined carbon. It is that cast iron is steel of CC ranging from 0 to 4%, with particles of graphite, which have no strength, enmeshed with it. The strength of the cast iron therefore is that of the steel or graphiteless iron containing the same percentage of CC, weakened in some proportion to the percentage of GC. The tensile strength of steel ranges approximately from 40,000 lb. per sq. in. with 0 C to 125,000 lb. with 1.20 C. With higher C it rapidly becomes weak and brittle. White cast iron with 3% CC is about 30,000 T.S., and with 4% about 18,000. The amount of weakening due to GC is not known, but by making a few assumptions we may construct a table of hypothetical strengths of different compositions, with which results of actual tests may be compared. Suppose the strength of the steel-white cast-iron series is as given below for different percentages of CC, that 6.25% GC entirely destroys the strength, and that the weakening effect of other percentages is proportional to the ratio of the square root of that percentage to the square root of 6.25, that the TC. in two irons is respectively 3% and 4%, then we have the following:

Per cent CC..	0	0.2	0.4	0.6	0.8	1.0	1.2	1.5	2.0	2.5	3	3.5	4
Steel, T.S....	40	60	80	100	110	120	125	110	60	40	30	22	18
Cast iron, 4%													
TC .....	8	13.2	19.2	26	31.2	37	41.5	40.5	26	20.7	18	15.8	18
Cast iron, 3%													
TC.....	15.4	19.9	28.5	38	42.9	52.1	58	56.1	36	28.7	30	....	..

The figures for strength are in thousands of pounds per sq. in. The table is calculated as follows: Take 0.6 CC; with 4% TC., this leaves 3.4 GC, and with 3% TC, 2.4 GC. The sq. root of 3.4 is 1.9, and of 2.4 is 1.55. The ratio of these to  $\sqrt{6.25}$  is respectively 74 and 62%, which subtracted from 100 leave 26 and 38% as the percentage of strength of the 0.6 C steel remaining after the effect of the GC is deducted. The table indicates that strength is increased as total C is diminished, and this agrees with general experience.

**Relation of Strength to Size of Bar as Cast.** — If it is desired that a test bar shall fairly represent a casting made from the same iron, then the dimensions of the bar as cast should correspond to the dimensions of the casting, so as to have about the same ratio of cooling surface to volume that the casting has. If the test bar is to represent the strength of a plate, it should be cut from the plate itself if possible or else cut from a cylindrical shell made of considerable diameter and of a thickness equal to that of the casting. If the test is for distinguishing the quality of the iron, then at least two test bars should be cast, one say  $\frac{1}{2}$  or  $\frac{5}{8}$  in. and one say 2 or  $2\frac{1}{2}$  in. diameter, in order to show the effect of rapid and slow cooling.

In 1904 the author made some tests of four bars of "semi-steel" advertised to have a strength of over 30,000 lb. per sq. in. The bars were cast  $\frac{1}{2}$ , 1, 2, and 3 in. diam., and turned to 0.46, 0.69, 1.6, and 1.85 in. respectively. The results of transverse and tensile tests were:

Mod. of rupture.	$\frac{1}{2}$ in.,	100,000;	1 in.,	61,613;	2 in.,	67,619;	3 in.,	58,543
T.S. per sq. in...	"	38,510;	"	37,005;	"	25,685;	"	20,375

The  $\frac{1}{2}$ -in. piece was so hard that it could not be turned in a lathe and had to be ground.

**Influence of Length of Bar upon the Modulus of Rupture.** — (R. Moldenke, *Jour. Am. Foundrymen's Assn.*, Sept., 1899.) Seven sets, each of five 2-in. square bars, made of a heavy machinery mixture, and cast on end, were broken transversely, the distance between supports ranging from 6 to 16 ins. The average results were:

Dist. bet. supports, ins....	6	8	10	12	14	16
Modulus of rupture.....	40,000	39,000	35,600	37,000	36,000	34,400

The 10-in. bar in six out of seven cases gave a lower result than the 12-in. It appears that the ordinary formulas used in calculating the cross breaking strength of beams are not only incorrect for cast iron, on account of the chemical differences in the iron itself when in different cross sections, but that with the cross sections identical the distance between the supports must be specially provided for by suitable constants in whatever formulae may be developed. As seen from the above results, the doubling of the distance between supports means a drop in the modulus of rupture in the same sized bar of nearly 10 per cent.

**Strength in Relation to Silicon and Cross-section.**— In castings one half-inch square in section the strength increases as silicon increases from 1.00 to 3.50; in castings 1 in. square in section the strength is practically independent of silicon, while in larger castings the strength decreases as silicon increases.

The following table shows values taken from Mr. Keep's curves of the approximate transverse strength of cast bars of different sizes reduced to the equivalent strength of a 1/2-in. × 12-in. bar.

Silicon, Per cent.	Size of Square Cast Bars.					Silicon, Per cent.	Size of Square Cast Bars.				
	1/2 in.	1 in.	2 in.	3 in.	4 in.		1/2 in.	1 in.	2 in.	3 in.	4 in.
	Strength of a 1/2-in. × 12-in. section, lb.						Strength of a 1/2-in. × 12-in. section, lb.				
1.00	290	260	232	222	220	2.50	392	278	212	190	184
1.50	324	272	228	212	208	3.00	426	276	202	180	172
2.00	358	278	220	202	196	3.50	446	264	192	168	160

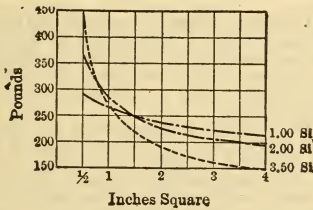

FIG. 98.

Fig. 98 shows the relation of the strength to the size of the cast-iron bar and to Si, according to the figures in the above table. Comparing the 2-in. bars with the 1/2-in. bars, we find

Si, per cent. ....	1	1.5	2	2.5	3	3.5
2-in. weaker than 1/2-in., per cent. . .	20	30	35	46	53	57

The fact that with the 1-in. bar the strength is nearly independent of Si, shows that it is the worst size of bar to use to distinguish the quality of the metal. If two bars were used, say 1/2-in. and 2-in., the drop in strength would be a better index to the quality than the test of any single bar could be.

**Shrinkage of Cast Iron.**— W. J. Keep (*A. S. M. E.* xvi., 1082) gives a series of curves showing that shrinkage depends on silicon and on the cross-section of the casting, decreasing as the silicon and the section increase. The following figures are obtained by inspection of the curves:

Silicon, Per cent.	Size of Square Bars.					Silicon, Per cent.	Size of Square Bars.				
	1/2 in.	1 in.	2 in.	3 in.	4 in.		1/2 in.	1 in.	2 in.	3 in.	4 in.
	Shrinkage, In. per Foot.						Shrinkage, In. per Foot.				
1.00	0.178	0.158	0.129	0.112	0.102	2.50	0.142	0.121	0.091	0.072	0.060
1.50	.166	.145	.116	.099	.088	3.00	.130	.109	.078	.058	.046
2.00	.154	.133	.104	.086	.074	3.50	.118	.097	.065	.045	.032

Mr. Keep says: "The measure of shrinkage is practically equivalent to a chemical analysis of silicon. It tells whether more or less silicon is

needed to bring the quality of the casting to an accepted standard of excellence."

A shrinkage of  $\frac{1}{8}$  in. per ft. is commonly allowed by pattern makers. According to the table, this shrinkage will be obtained by varying the Si in relation to the size of the bar as follows:  $\frac{1}{2}$  in., 3.25 Si; 1 in., 2.4 Si; 2 in., 1.1 Si; 3 and 4, less than 1.0 Si.

**Shrinkage and Expansion of Cast Iron in Cooling.** (T. Turner, *Proc. I. & S. I.*, 1906.)—Some irons show the phenomenon of expanding immediately after pouring, and then contracting. Four irons were tested, analyzing as follows: (1) "Washed" white iron, CC 2.73; Si, 0.01; P, 0.01; Mn and S, traces. (2) Gray hematite, GC, 2.53; CC, 0.86; Si, 3.47; Mn, 0.55; P, 0.04; S, 0.03. (3) Northampton, GC, 2.60; CC, 0.15; Si, 3.98; Mn, 0.50; P, 1.25; S, 0.03. (4) Cast iron, GC, 2.73; CC, 0.79; Si, 1.41; Mn, 0.43; P, 0.96; S, 0.07. No. 1 was stationary for 5 seconds after pouring, shrunk 125 sec., stationary 10 sec., then shrunk till cold. No. 2 expanded 15 sec., shrunk 20 sec. to original size, continued shrinking 90 sec. longer, stationary 10 sec., expanded 30 sec., then shrunk till cold. No. 3 expanded irregularly with three expansions and two shrinkages, until 125 sec. after pouring the total expansion was 0.019 in. in 12 in., then shrunk till cold. No. 4 expanded 0.08 in. in 50 sec., then shrunk till cold.

**Shrinkage Strains Relieved by Uniform Cooling.** (F. Schumann, *A.S.M.E.*, xvii, 433.)—Mr. Jackson in 1873 cast a flywheel with a very large rim and extremely small straight arms. Cast in the ordinary way, the arms broke either at the rim or at the hub. Then the same pattern was molded so that large chunks of iron were cast between the arms, a thickness of sand separating them. Cast in this way, all the arms remained unbroken.

**Deformation of Castings from Unequal Shrinkage.**—(F. Schumann, *A. S. M. E.*, vol. xvii.) A prism cast in a sand mold will maintain its alignment, after cooling in the mold, provided all parts around its center of gravity of cross section cool at the same rate as to time and temperature. Deformation is due to unequal contraction, and this is due chiefly to unequal cooling.

Modifying causes that effect contraction are: Imperfect alloying of two or more different irons having different rates of contraction; variations in the thickness of sand forming the mold; unequal dissipation of heat, the upper surface dissipating the greater amount of heat; position and form of cores, which tend to resist the action of contraction, also the difference in conducting power between moist sand and dry-baked cores; differences in the degree of moisture of the sand; unequal exposure by the removal of the sand while yet in the act of contracting; flanges, ribs, or gussets that project from the side of the prism, of sufficient area to cause the sand to act as a buttress, and thus prevent the natural longitudinal adjustment due to contraction; in light castings of sufficient length the unyielding sand between the flanges, etc., may cause rupture.

**Irregular Distribution of Silicon in Pig Iron.**—J. W. Thomas (*Iron Age*, Nov. 12, 1891) finds in analyzing samples taken from every other bed of a cast of pig iron that the silicon varies considerably, the iron coming first from the furnace having generally the highest percentage. In one series of tests the silicon decreased from 2.040 to 1.713 from the first bed to the eleventh. In another case the third bed had 1.260 Si, the seventh 1.718, and the eleventh 1.101. He also finds that the silicon varies in each pig, being higher at the point than at the butt. Some of his figures are: Point of pig, 2.328 Si; butt of pig, 2.157; point of pig, 1.834; butt of pig, 1.787.

**White Iron Converted into Gray by Heating.** (A. E. Outerbridge, Jr., *Proc. Am. Socy. for Testing Mat's*, 1902, p. 229.)—When white chilled iron containing a considerable amount of Si and low in GC is heated to about 1850° F. from  $3\frac{1}{2}$  to 10 hours the CC is changed into C, which differs materially from graphite, and a metal is formed which has properties midway between those of steel and cast iron. The specific gravity is raised from 7.2 to about 7.8; the fracture is of finer grain than normal gray iron; and the metal is capable of being forged, hardened, and taking a sharp cutting edge, so that it may be used for axes, hatchets, etc. It differs from malleable cast iron, since the latter has its carbon removed by oxidation, while the converted cast iron retains its original total



carbon, although in a changed form. The tensile strength of the new metal is high, 40,000 to 50,000 lb. per sq. in., with very small elongation. The peculiar change from white to gray iron does not take place if Si is low. The analysis of the original castings should be about TC, 3.4 to 3.8; Si, 0.9 to 1.2; Mn, 0.35 to 0.20; S, 0.05 to 0.04; P, 0.04 to 0.03. The following shows the change effected by the heat treatment:

Before annealing, GC, 0.72; CC, 2.60; Si, 0.71; Mn, 0.11; S, 0.045; P, 0.04  
 After annealing, GC, 2.75; CC, 0.82; Si, 0.73; Mn, 0.11; S, 0.040; P, 0.04

The GC after annealing is, however, not ordinary graphite, but an allotropic form, evidently identical with what Ledebur calls "tempering graphite carbon."

**Change of Combined to Graphitic Carbon by Heating.**—(H. M. Howe, *Trans. A. I. M. E.*, 1908, p. 483.) On heating white cast iron to different temperatures for some hours, the carbon changes from the combined to the graphitic state to a degree which increases in general with the temperature and with the silicon-content. With 0.05 Si, a little graphite formed at 1832° F.; with 0.13 Si, at 1652° F.; with 2.12 Si, graphite formed at a moderate rate at 1112°, and with 3.15 Si, it formed rapidly at 1112° F. In iron free from Si, with 4.271 comb. C. and 0.255 graphitic, none of the C. was changed to graphite on long heating to from 1680° to 2040° F., but in iron with 0.75 Si the graphite, originally 0.938%, rose to 1.69% on heating to 1787°, and to 2.795% on heating to 2057° F. On the other hand, when carbon enters iron, as in the cementation process in making blister-steel, it appears chiefly as cementite (combined carbon). Also on heating iron containing graphite to high temperatures and cooling quickly, some of the graphite is changed to cementite.

**Mobility of Molecules of Cast Iron.** (A. E. Outerbridge, Jr., *A. I. M. E.*, xxvi, 176; xxxv, 223.)—Within limits, cast iron is materially strengthened by being subjected to repeated shocks or blows. Six bars 1 in. sq., 15 in. long, subjected for about 4 hours to incessant blows in a tumbling barrel, were 10 to 15% stronger than companion bars not thus treated. Six bars were struck 1000 blows on one end only with a hand hammer, and they showed a like gain in strength. The increase is greater in hard mixtures, or strong iron, than in soft mixtures, or weak iron; greater in 1-in. bars than in 1/2-in., and somewhat greater in 2-in. than in 1-in. bars. Bars were treated in a machine by dropping a 14-lb. weight on the middle of a 1-in. bar, supports 12 in. apart. Six bars were first broken by having the weight fall a sufficient distance to break them at the first blow, then six companion bars were subjected to from 10 to 50 blows of the same weight falling one-half the former distance, and then the weight was allowed to fall from the height at which the first bars broke. Not one of the bars broke at the first blow; and from 2 to 10, and in one case 15 blows from the extreme height were required to break them. Mr. Outerbridge believes that every casting when first made is under a condition of strain, due to the difference in the rate of cooling at the surface and near the center, and that it is practicable to relieve these strains by repeatedly tapping the casting, allowing the particles to rearrange themselves and assume a new condition of molecular equilibrium. The results, first reported in 1896, were corroborated by other experimenters. A report in *Jour. Frank. Inst.*, 1898, gave tests of 82 bars, in which the maximum gain in strength compared with untreated bars was 40%, and the maximum increase in deflection was 41%.

In his second paper, 1904, Mr. Outerbridge describes another series of tests which showed that 1-in. sq. bars 15 in. long subjected to repeated heating and cooling grew longer and thicker with each successive operation. One bar heated about an hour each day to about 1450° F. in a gas furnace for 27 times increased its length 1 11/16 in. and its cross-section 1/8 in. Soft iron expands more rapidly than hard iron. White iron does not expand sufficiently to cover the original shrinkage. Wrought iron and steel bars similarly treated in a closed tube all contracted slightly, the average contraction after 60 heatings being 1/8 in. per foot. The strength and deflection of the cast-iron bars was greatly decreased by the treatment, 1250 as compared with 2150 lb., and 0.1 in. deflection as compared with 0.15 in. The specific gravity of the expanded bars was 5.49 to 6.01, as compared with 7.13 for the untreated bars.

Grate bars of boiler furnaces grow larger in use, as do also cast-iron pipes in ovens for heating air.

**Castings from Blast Furnace Metal.** Castings are frequently made from iron run directly from the blast furnace, or from a ladle filled with furnace metal. Such metal, if high in Si, is more apt to throw out "kish" or loose particles of graphite than cupola metal. With the same percentage of Si, it is softer than cupola metal, which is due to two causes: 1, lower S; 2, higher temperature. T. D. West, *A.I.M.E.*, xxxv, 211, reports an example of furnace metal containing Si, 0.51; S, 0.045; Mn, 0.75; P, 0.094; which was easily planed, whereas if it had been cupola metal it would have been quite hard. J. E. Johnson, Jr., *ibid.*, p 213, says that furnace metal with S, 0.03, and Si, 0.7, makes good castings, not too hard to be machined. Should the metal contain over 0.9 Si, difficulty is experienced in preventing holes and soft places in the castings, caused by the deposition of kish or graphite during or after pouring. The best way to prevent this is to pour the iron very hot when making castings of small or moderate size.

**Effect of Cupola Melting.** (G. R. Henderson, *A.S.M.E.*, xx, 621.)—27 car-wheels were analyzed in the pig and also after remelting. The P remains constant, as does Si when under 1%. Some of the Mn always disappears. The total C remains the same, but the GC and CC vary in an erratic manner. The metal charged into the cupola should contain more GC, Si and Mn than are desired in the castings. Fairbairn (*Manufacture of Iron*, 1865) found that remelting up to 12 times increased the strength and the deflection, but after 18 remeltings the strength was only  $\frac{5}{8}$  and the deflection  $\frac{1}{3}$  of the original. The increase of strength in the first remeltings was probably due to the change of GC into CC, and the subsequent weakening to the increase of S absorbed from the fuel.

**Hard Castings from Soft Pig.** (B. F. Fackenthal, Jr., *A.I.M.E.*, xxxv, 993.)—Samples from a car load of pig gave Si, 2.61; S, 0.023. Castings from the same iron gave 2.33 and 2.26 Si, and 0.26 and 0.25 S, or 12 times the S in the original pig; probably due to fuel too high in S, but more probably to the use of too little fuel in remelting.

The loss of Si in remelting, and the consequent hardening, is affected by the amount of Mn, as shown below:

Mn, per cent. . . . .	0.04	0.20	0.43	0.53
Si lost in remelting, per cent. . . . .	34	23	12	4

**Difficult Drilling due to Low Mn.**—H. Souther, *A.S.T.M.*, v, 219, reports a case where thin castings drilled easily while thick parts on the same castings rapidly dulled  $\frac{1}{2}$  and  $\frac{3}{4}$ -in. drills. The chemical constitution was normal except Mn; Si, 2.5; P, 0.7; S about 0.08; C, 3.5; Mn, 0.16. When the Mn was raised to 0.5 the trouble disappeared.

**Addition of Ferro-silicon in the Ladle.** (A. E. Outerbridge, *Proc. A.S.T.M.*, vi, 263.)—Half a pound of FeSi, containing 50% Si, added to a 200-lb. ladle of soft cast iron used for making pulleys with rims  $\frac{1}{4}$  in. thick, prevented the chilling of the surface of the casting, and enabled the pulleys to be turned more rapidly. Analysis showed that the actual increase of the Si in the casting was less than the calculated increase. Tests of the metal treated with FeSi as compared with untreated metal showed a gain in strength of from 2 to 26%, and a gain in deflection of 2 to 3%. The reason assigned for the increase of strength with increase of softness is that cupola iron contains a small amount of iron oxide, which reacts with the Si added in the ladle, forming SiO<sub>2</sub>, which goes into the slag.

**Additions of Vanadium and Manganese.**—R. Moldenke, Am. Fdrymen's Assn., 1908, *Am. Mach.*, Feb. 20, '08. Experiments were made by adding to melted cast iron in the ladle a ground alloy of ferro-vanadium, containing 14.67 Va, 6.36 C, and 0.18 Si. In other experiments ferro-manganese (80% Mn) was added, together with the vanadium. Four kinds of iron were used: burnt gray iron (gratebars, stove iron, etc.), burnt white iron, gray machinery iron (Si, 2.72, S, 0.065, P, 0.068, Mn, 0.54) and remelted car wheels (white, two samples analyzed: Si, 0.60 and 0.53, S, 0.122, 0.138; P, 0.399, 0.374; Mn, 0.38, 0.44). The bars were  $\frac{1}{4}$  in. diam., 12 in. between supports. The burnt gray iron was increased in breaking strength from 1310 to 2220 lb. by the addition of 0.05% Va, and the burnt white iron from 1440 to 1910 lb. by the addition of 0.05 Va and 0.50 Mn. The following are average results:

Gray Machinery Iron.				Remelted Car Wheels.			
Added Per cent.		Breaking Strength, Lb.	Deflection, In.	Added Per cent.		Breaking Strength, Lb.	Deflection, In.
Va.	Mn.			Va.	Mn.		
0.0	0.0	1980	0.105	0.0	0.0	1470	0.050
0.0	0.50	1970	0.100	.....	0.50	2790	0.070
0.05	.....	1980	0.100	0.05	.....	3020	0.060
0.05	0.50	2130	0.100	0.05	0.50	2970	0.090
0.10	.....	2372	0.090	0.10	.....	2800	0.055
0.10	0.50	2530	0.120	0.10	0.50	3030	0.090
0.15	.....	2360	0.100	0.15	.....	2950	0.070
	bars	.....	.....	0.15	0.50	3920	0.095
Average treated		2224				3069	
Mod. of rupture... 35,800				48,020			

Experiments with Titanium added to cast iron in the ladle are reported by R. Moldenke, *Proc. Am. Foundrymen's Assn.*, 1908. Two irons were used: gray, with 2.58 Si, 0.042 S, 0.54 P, 0.74 Mn; and white, with 0.85 Si, 0.07 S, 0.42 P, 0.6 Mn. Two Fe Ti alloys with 10% Ti were used, one containing no C, and the other 5% C. The latter has the lower melting point. The results were as below:

		Gray Iron.			White Iron.	Lb.
Original iron.....	9 tests	1720-2260 av.	2020	8 tests	1920-2110 av.	2050
Plus 0.05 Ti.....	4 tests	2750-3140 "	3100	11 tests	2210-2660 "	2400
Plus 0.10 Ti.....	3 tests	2880-3150 "	3030	.....	.....	.....
Plus 0.05 Ti and C	6 tests	2850-3230 "	3070	9 tests	2230-2720 "	2420
Plus 0.10 Ti and C	6 tests	2850-3150 "	2990	10 tests	2320-2460 "	2400
Plus 0.15 Ti and C	4 tests	3030-3270 "	3190	10 tests	2280-2620 "	2520
Average of treated iron.....		3070				2430
Increase over original.....		52%				18%
Modulus of rupture, treated iron..... 48,030				38,020		

The test bars were 1 1/4 in. diam. 12 in. between supports. The improvement is as marked whether 0.05, 0.10, or 0.15% Ti is used, which indicates that if sufficient Ti is used for deoxidation of the iron, any additional Ti is practically wasted.

Ti lessens the chilling action, yet whatever chill remains shows much harder iron. Test pieces made with iron which chilled 1 1/2 in. deep gave but 1 in. chill when the iron was treated in the ladle. The original iron crushed at 173,000 lbs. per sq. in. and stood 445 in Brinel's test for hardness, soft steel running about 105. The treated piece ran 298,000 lbs. per sq. in. and showed a hardness of 557. Testing the soft metal below the chilled portion for hardness gave 332 for the original and 322 for the treated piece.

**Strength of Cast-Iron Beams.**—C. H. Benjamin, *Mach'y*, May, 1906. Numerous tests were made of beams of different sections including hollow rectangles and cylinders, I and T-shapes, etc. All the sections were made approximately the same area, about 4.4 sq. in., and all were tested by transverse loading, with supports 18 in. apart. The results, when reduced by the ordinary formula for stress on the extreme fiber,  $S = My/I$ , showed an extraordinary variation, some of the values being as follows: Square bar, 23,300; Round bar, 25,000. Hollow round, 3.4 in. outside and 2.5 in. inside diam., 26,450, and 35,800. Hollow ellipse, 3 in. wide, 3.9 in. high, 0.9 in. thick, 36,000. I-beam, 4 in. high, web 0.44 in. thick, 17,700. The hollow cylindrical and elliptical sections are much stronger than the solid sections. This is due to the thinner metal, the greater surface of hard skin, and freedom from shrinkage strains. Professor Benjamin's conclusions from these tests are:

- (1) The commonly accepted formulas for the strength and stiffness of beams do not apply well to cored and ribbed sections of cast iron.
- (2) Neither the strength nor the stiffness of a section increases in proportion to the increase in the section modulus or the moment of inertia.
- (3) The best way to determine these qualities for a cast-iron beam is by experiment with the particular section desired and not by reasoning from any other section.



**Bursting Strength of Cast-Iron Cylinders.** — C. H. Benjamin, *A. S. M. E.*, XIX, 597; *Mach'y*, Nov., 1905. Four cylinders, 20 in. long, 10 1/8 in. int. diam., 3/4 in. thick, with flanged ends and bolted covers, burst at 1350, 1400, 1350, and 1200 lbs. per sq. in. hydraulic pressure, the corresponding fiber stress, from the formula  $S = pd/2t$ , being 9040, 10,200, 9735 and 9080. Pieces cut from the shell had an average tensile strength of 14,000 lbs. per sq. in., and a modulus of rupture in transverse tests of 30,000.

**Transverse Strength of Cast-Iron Water-pipe.** (*Technology Quarterly*, Sept., 1897.)—Tests of 31 cast-iron pipes by transverse stress gave a maximum outside fibre stress, calculated from maximum load, assuming each half of pipe as a beam fixed at the ends, ranging from 12,800 lb. to 26,300 lb. per sq. in.

Bars 2 in. wide cut from the pipes gave moduli of rupture ranging from 28,400 to 51,400 lb. per sq. in. Four of the tests, bars and pipes:

Moduli of rupture of bar.....	28,400	34,400	40,000	51,400
Fibre stress of pipe.....	18,300	12,800	14,500	26,300

These figures show a great variation in the strength of both bars and pipes, and also that the strength of the bar does not bear any definite relation to the strength of the pipe.

**Bursting Strength of Flanged Fittings.** — *Power*, Feb. 4, 1908. The Crane Company, Chicago, published in the *Valve World* records of tests of tees and ells, standard and extra heavy, which show that the bursting strength of such fittings is far less than is given by the standard formulæ for thick cylinders. As a result of the tests they give the following empirical formula:  $B = TS/D$ , in which  $B$  = bursting pressures, lbs. per sq. in.,  $T$  = thickness of metal,  $D$  = inside diam., and  $S$  = 65% of the tensile strength of the metal for pipes up to 12 in. diam., for larger sizes use 60%. The pipes were made of "ferro-steel" of 33,000 lbs. T. S., and of cast iron of 22,000 lbs. as tested in bars. The following are the principal results of tests of extra heavy tees and ells compared with results of calculation by the Crane Company's formula:

**BURSTING STRENGTH OF PIPE-FITTINGS. POUNDS PER SQUARE INCH.**

Inside Diam. Thickness.	6	8	10	12	14	16	18	20	24
	3/4	13/16	15/16	1	1 1/8	1 3/16	1 1/4	1 5/16	1 1/2
B, Ferro-steel.....	2733	2250	2160	2033	1825	1700	1450	1275	1300
calculated.....	2680	2180	2010	1870	1570	1450	1350	1280	1220
B, Cast iron.....	1687	1350	1306	1380	1100	1025	600	750	700
calculated.....	1790	1450	1340	1190	1060	980	920	870	820
Ells, ferro steel....	3266	2725	2350	2133	.....	.....	.....	.....	.....
" cast-iron.....	2275	1625	1541	1275	1075	1250	.....	.....	.....

**Specific Gravity and Strength.** (Major Wade, 1856.)

Third-class guns: Sp. Gr. 7.087, T. S. 20,148. Another lot: least Sp. Gr. 7.163, T. S. 22,402.

Second-class guns: Sp. Gr. 7.154, T. S. 24,767. Another lot: mean Sp. Gr. 7.302, T. S. 27,232.

First-class guns: Sp. Gr. 7.204, T. S. 28,805. Another lot: greatest Sp. Gr. 7.402, T. S. 31,027.

**Strength of Charcoal Pig Iron.** — Pig iron made from Salisbury ores, in furnaces at Wassaic and Millerton, N. Y., has shown over 40,000 lbs. T. S. per square inch, one sample giving 42,281 lbs. Muirkirk, Md., iron tested at the Washington Navy Yard showed: average for No. 2 iron, 21,601 lbs.; No. 3, 23,959 lbs.; No. 4, 41,329 lbs.; average density of No. 4, 7.336 (*J. C. I. W.*, v. p. 44).

Nos. 3 and 4 charcoal pig iron from Chapinville, Conn., showed a tensile strength per square inch of from 34,761 lbs. to 41,882 lbs. Charcoal pig iron from Shelby, Ala. (tests made in August, 1891), showed a strength of 34,800 lbs. for No. 3; No. 4, 39,675 lbs.; No. 5, 46,450 lbs.; and a mixture of equal parts of Nos. 2, 3, 4, and 5, 41,470 lbs. (*Bull. I. & S. A.*)

**Variation of Density and Tenacity of Gun-Irons.** — An increase of density invariably follows the rapid cooling of cast iron, and as a general rule the tenacity is increased by the same means. The tenacity generally increases quite uniformly with the density, until the latter ascends

to some given point; after which an increased density is accompanied by a diminished tenacity.

The turning-point of density at which the best qualities of gun-iron attain their maximum tenacity appears to be about 7.30. At this point of density, or near it, whether in proof-bars or gun-heads, the tenacity is greatest.

As the density of iron is increased its liquidity when melted is diminished. This causes it to congeal quickly, and to form cavities in the interior of the casting. (Pamphlet of Builders' Iron Foundry, 1893.)

"Semi-steel" is a trade name given by some founders to castings made from pig iron melted in the cupola with additions of from 20 to 30 per cent of steel scrap. Ferro-manganese is also added either in the cupola or in the ladle. The addition of the steel dilutes the Si of the pig iron, and changes some of the C from GC to CC, but the TC is unchanged, for any reduction made by the steel is balanced by absorption of C from the fuel. Semi-steel therefore is nothing more than a strong cast iron, low in Si and containing some Mn, and the name given it is a misnomer.

**Mixture of Cast Iron with Steel.** — Car wheels are sometimes made from a mixture of charcoal iron, anthracite iron, and Bessemer steel. The following shows the tensile strength of a number of tests of wheel mixtures, the average tensile strength of the charcoal iron used being 22,000 lbs. (*Jour. C. I. W.*, iii, p. 184):

	lbs. per sq. in.
Charcoal iron with 21/2% steel .....	22,467
" " " 33/4% steel .....	26,733
" " " 61/4% steel and 61/4% anthracite .....	24,400
" " " 71/3% steel and 71/2% anthracite .....	28,150
" " " 21/2% steel, 21/2% wro't iron, and 61/4% anth. ....	25,550
" " " 5 % steel, 5% wro't iron, and 10% anth....	26,500

**Cast Iron Partially Bessemerized.** — Car wheels made of partially Bessemerized iron (blown in a Bessemer converter for 31/2 minutes), chilled in a chill test mold over an inch deep, just as a test of cold blast charcoal iron for car wheels would chill. Car wheels made of this blown iron have run 250,000 miles. (*Jour. C. I. W.*, vi, p. 77.)

**Bad Cast Iron.** — On October 15, 1891, the cast-iron fly-wheel of a large pair of Corliss engines belonging to the Amoskeag Mfg. Co., of Manchester, N.H., exploded from centrifugal force. The fly-wheel was 30 feet diameter and 110 inches face, with one set of 12 arms, and weighed 116,000 lbs. After the accident, the rim castings, as well as the ends of the arms, were found to be full of flaws, caused chiefly by the drawing and shrinking of the metal. Specimens of the metal were tested for tensile strength, and varied from 15,000 lbs. per square inch in sound pieces to 1000 lbs. in spongy ones. None of these flaws showed on the surface, and a rigid examination of the parts before they were erected failed to give any cause to suspect their true nature. Experiments were carried on for some time after the accident in the Amoskeag Company's foundry in attempting to duplicate the flaws, but with no success in approaching the badness of these castings.

**Permanent Expansion of Cast Iron by Heating.** (*Valve World*, Sept., 1908.) — Cast iron subjected to continued temperatures of approximately 500° to 600° took a permanent expansion and did not return to its original volume when cooled.

As steam is being superheated quite commonly to temperatures above 575°, this fact is of great interest inasmuch as it modifies our ideas about the proper material to be used in the construction of valves and fittings for service under high temperatures. A permanent volumetric expansion is followed by a loss of strength, the loss in cast iron being fully 40 per cent in four years.

Crane Co. made an attempt to determine whether cast steel was affected in the same manner as cast iron. Three flanges were taken, one of cast iron, one of ferrosteel, and the third of cast steel. These flanges were exposed for a total period of 130 hours to temperatures ranging as follows:

Less than 500°, 18 hours; 500° to 700°, 97 hours; 710° to 800°, 12 hours; over 800°, 3 hours. Average temp., 583°.

The outside diameter in each case was 12 1/2 in. and the bore 6 29/64 in. The results were: Cast-steel flange, no change. Cast-iron flange, outside diam. increased 0.019 in., inside diam. increased 0.007 in. Ferro-steel flange, outside diam. increased 0.033 in., inside diam. increased 0.017 in.

If the permanent expansion of cast iron stopped at the figures given above, it would not be a serious matter; but all evidence points toward a steady increase as time goes on, as was shown by one of Crane Co.'s 14-in. valves, which originally was 22 $\frac{1}{2}$  in. face to face, and increased  $\frac{5}{16}$  in. in length in four years under an average temperature of about 590°.

### MALLEABLE CAST IRON.\*

There are four great classes of work for whose requirements malleable cast iron (commonly called "malleable iron" in America) is especially adapted. These are agricultural implements, railway supplies, carriage and harness castings and pipe fittings. Besides these main classes there are innumerable other unclassified uses. The malleable casting is seldom over 175 lb. in weight, or 3 ft. in length, or  $\frac{3}{4}$  in. thick. The great majority of even the heavier castings do not exceed 10 lb.

When properly made, malleable cast iron should have a tensile strength of 42,000 to 48,000 lb. per sq. in., with an elongation of 5% in 2 in. Bars 1 in. square and on supports 12 in. apart should show a transverse strength of 2500 to 3500 lb., with a deflection of at least  $\frac{1}{2}$  in.

While the strength of malleable iron should be as stated, much of it will fall as low as 35,000 lb. per sq. in., and this will still be good for such work as pipe fittings, hardware castings and the like. On the other hand, even 63,000 lb. per sq. in. has been reached, with a load of 5000 lb. and a deflection of 2  $\frac{1}{2}$  in. in the transverse test. This high strength is not desirable, as the softness of the casting is sacrificed, and its resistance to continued shock is lessened. For the repeated stresses of severe service the malleable casting ranks ahead of steel, and only where a high tensile strength is essential must it be replaced by that material.

The process of making malleable iron may be summarized as follows: The proper cast irons are melted in either the crucible, the air furnace, the open-hearth furnace, or the cupola. The metal when cast into the sand molds must chill white or not more than just a little mottled. After removing the sand from the hard castings they are packed in iron scale, or other materials containing iron oxide, and subjected to a red heat (1250 to 1350° F.) for over 60 hours. They are then cooled slowly, cleaned from scale, chipped or ground, and straightened. Much of the malleable iron made to-day (1915) is annealed for a shorter time and at higher temperatures. The safe method, however, is the one given above.

When hard, or just from the sand, the composition of the iron should be about as follows: Si, from 0.35 up to 1.00, depending upon the thickness and the purpose the casting is to be used for; P not over 0.225, Mn not over 0.20, S not over 0.08. The total carbon can be from 2.75 upward, 4.15 being about the highest that can be carried. The lower the carbon the stronger the casting subsequently. Below 2.75 there is apt to be trouble in the anneal, the black-heart structure may not appear, and the castings remain weak. A casting 1 in. thick would necessitate silicon at 0.35, and the use of chills in the mold in addition, to get the iron white. For a casting  $\frac{1}{2}$  in. thick, Si about 0.60 is the proper limit, except where great strength is desired, when it can be dropped to 0.45. Above 0.60 there is danger of getting heavily-mottled if not gray iron from the sand molds, and this material, when annealed the long time required for the white castings, would be ruined. For very thin castings, Si can run up to 1.25 and still leave the metal white in fracture.

**Pig Iron for Malleable Castings.**—The specifications run as follows: Si, 0.75, 1.00, 1.25, 1.50, 1.75, 2.00%, as required; Mn, not over 0.60; P, not over 0.225; S, not over 0.05.

Works making heavy castings almost exclusively specify Si to include 0.75 up to 1.50%. Makers of very light work take 1.25 to 2.00%.

**The Melting Furnace.**—Malleable iron is melted in the reverberatory furnace, the open-hearth furnace, and the cupola, the reverberatory being the most extensively used. About 85 per cent of the entire output of the United States is melted by this process. Prior to about 1885, the standard furnace was one of 5 tons capacity. At present (1915) we

\* References.—R. Moldenke, *Cass Mag.*, 1907, and *Iron Trade Review*, 1908; E. C. Wheeler, *Iron Age*, Nov. 9, 1899; C. H. Gale, *Indust. World*, April 13, 1908; W. H. Hatfield, *ibid.* G. A. Akerlund, *Iron Tr. Rev.*, Aug. 23, 1906; C. H. Day, *Am. Mach.*, April 5, 1906.



have furnaces of 25 and 30 tons capacity, though furnaces of from 10 to 15 tons are the most popular and give more uniform results than those of larger capacity.

The adoption of the open-hearth furnace for malleable iron dates back to about 1893. It is used largely in the Pittsburg district.

Cupola-melted iron does not possess the tensile strength nor ductility of iron melted in the reverberatory or open-hearth furnace, due partly to the higher carbon and sulphur caused by the metal being in contact with the fuel. This feature is rather an advantage than otherwise, as most of the product of cupola-melted iron consists of pipe fittings, castings that are not subjected to any great stress or shock. The castings are threaded, and a strong, tough malleable iron does not cut a clean, smooth thread, but rather will rough up under the cutting tool.

In the reverberatory and open-hearth furnaces the metal may be partly desilicized at will, by an oxidizing flame or by additions of scrap or other low-silicon material, while the total carbon can be lowered by scrap steel additions. Manganese is also oxidized in the furnace.

The composition of good castings in American practice is: Si. from 0.45 to 1.00%; Mn. up to 0.30%; P, up to 0.225%; S, up to 0.08%; total carbon in the hard casting, above 2.75%.

In special cases, especially for very small castings, the silicon may go up as high as 1.25%, while for very heavy work it may drop down to 0.35% with very good results. In the case of charcoal iron this figure gives the strongest castings. With coke irons, however, especially when steel scrap additions are the rule, 0.45 should be the lower limit, and 0.65 is the best silicon for all-around medium and heavy work, such as railroad castings.

In American practice phosphorus is required not to exceed 0.225%, and is preferred lower. In European practice it is required as low as 0.10%, but castings have been made successfully with P as high as 0.40%.

The heat treatment of metal during melting has an important bearing upon its tensile strength, elongation, etc. Excessive temperatures promote the chances of burning. Iron is burnt mainly through the generation in melting furnaces of higher temperatures than those prevailing during the initial casting at blast furnaces and an excess of air in the flame. The choicest irons may thus turn out poor material.

**Shrinkage of the Casting.** — The shrinkage of the hard casting is about 1/4 in. to the foot, or double that of gray iron. In annealing about half of this is recovered, and hence the net result is the same as in ordinary foundry pattern practice. The effect of this great shrinkage is to cause shrinkage cracks or sponginess in the interior of the casting. As soon as the liquid metal sets against the surface of the mold and the source of supply is cut off, the contraction of the metal in the interior as it cools causes the particles to be torn apart and to form minute cracks or cavities. "Every test bar, and for that matter every casting may be regarded as a shell of fairly continuous metal with an interior of slight planes of separation at right angles to the surface. This characteristic of malleable iron forms the basis of many a mysterious failure." (*Moldenke.*)

**Packing for Annealing.** — After the castings have been chipped and sorted they are packed in iron annealing pots, holding about 800 pounds of iron, together with a packing composed of iron ore, hammer and rolling mill scale, turnings, borings, etc. The turnings, etc., were formerly treated with a solution of salammoniac or muriatic acid to form a heavy coating of oxide, but such treatment is now considered unnecessary. Blast furnace slag, coke, sand, and fire clay have also been used for packing. The changes in chemical composition of the castings when annealed in slag and in coke are given as follows by C. H. Gale:

	Si.	S.	P.	Mn.	C. C.	G. C.
Hard iron . . . . .	0.63	0.043	0.147	0.21	2.54	Trace
Annealed in slag . . . . .	0.61	0.049	0.145	0.21	0.24	1.65
Annealed in coke . . . . .	0.61	0.065	0.150	0.21	0.25	2.00

**The Annealing Process.**—The effect of the annealing is to oxidize and remove the carbon from the surface of the casting, to remove it to a greater or less degree below the surface, and to convert the remain-

ing carbon from the combined form into the amorphous form called a "temper carbon" by Professor Ledebur, the German metallurgist. It differs from the graphite found in pig iron, but is usually reported as graphitic carbon by the chemists. In the original malleable process, invented by Reaumur, in 1722, the castings were packed in iron ore and annealed thoroughly, so that most of the carbon was probably oxidized, but in American practice the annealing process is rather a heat treatment than an oxidizing process, and its effect is to precipitate the carbon rather than to eliminate it. According to the analysis quoted above, the metal annealed in slag lost 0.65% of its total C, while that annealed in coke lost only 0.29%. In the former, S increased 0.006% and in the latter 0.022%. The Si decreased 0.02% in both cases, while the P and Mn remained constant.

As to the distribution of carbon in an annealed casting, Dr. Moldenke says: "Take a flat piece of malleable and plane off the skin, say  $\frac{1}{16}$  in. deep and gather the chips for analysis. The carbon will be found, say, 0.15% perhaps even less. Cut in another  $\frac{1}{16}$  in. and the total C will be nearer 0.60%. Now go down successively by sixteenths and the total C will range from, say, 1.70 to 3.65% and will then remain constant until the center is reached." "The malleable casting is for practical purposes a poor steel casting with a lot of graphite, not crystallized, between the crystals or groups of crystals of the steel."

The heat in the annealing process must be maintained for from two to four days, depending upon the thickness of sections of the castings and the compactness with which the castings or annealing boxes are placed in the furnace. An annealing temperature 1550° to 1600° Fahr. is often used, but it is not essential, as the annealing can be accomplished at 1300°, but the time required will be longer than that at the higher temperature. Burnt iron in the anneal is no uncommon feature, and, generally speaking, it is the result of carelessness. The most carefully prepared metal from melting furnaces can here be turned into worthless castings by some slight inattention of detail. The highest temperature for annealing should be registered in each foundry, and kept there by the daily and frequent use of a thermometer constructed for that sole purpose. Steady, continued heat insures soft castings, while unequal temperatures destroy all chances for successful work, although the initial metal was of the most excellent quality.

**After annealing**, the castings are cleaned by tumblers or the sand blast; they are carefully examined for cracks or other defects, and if sprung out of shape are hammered or forced by hydraulic power to the correct shape. Such parts as are produced in great quantities are placed in a drop hammer and one or two blows will insure a correct form. They may be drop-forged or even welded when the iron has been made for that purpose. Castings are sometimes dipped into asphaltum diluted with benzine to give them a better finish.

Malleable castings must never be straightened hot, especially when thick. In the case of very thin castings there is some latitude, as the material is so decarbonized that it is nearer a steel than genuine malleable cast iron. In heating portions of castings that were badly warped, it seems that the amorphous carbon in them was combined again, and while the balance of the casting remained black and sound, the heated parts became white and brittle, as in the original hard casting. Hence the advice to straighten the castings cold, preferably with a drop hammer and suitable dies, or still better in the hydraulic press. (R. Moldenke. *Proc. A. S. T. M.*, vi, 244.)

**Physical Characteristics.** — The characteristic that gives malleable iron its greatest value as compared with gray iron is its ability to resist shocks. Malleability in a light casting  $\frac{1}{4}$  in. thick and less means a soft, pliable condition and the ability to withstand considerable distortion without fracture, while in the heavy sections,  $\frac{1}{2}$  in. and over, it means the ability to resist shocks without bending or breaking.

For general purposes it is not altogether desirable to have a metal very high in tensile strength, but rather one which has a high transverse strength, and especially a good deflection. It is not always that a strong and at the same time soft material can be produced in a foundry operating on the lighter grades of castings. The purchaser, therefore, unless he requires very stiff material, should rather look upon the deflection of

the metal coupled with the weight it took to do this bending before failure, than for a high tensile strength.

The ductility of the malleable casting permits the driving of rivets, which cannot so readily be done with gray cast iron; and for certain parts of cars, like the journal boxes, malleable cast iron may be considered supreme, leaving cast iron and "semi-steel" far behind.

It was formerly the general belief that the strength of malleable iron was largely in the white skin always found on this material, but it has been demonstrated that the removal of the skin does not proportionately lessen the strength of the casting.

**Test Bars.** — The rectangular shape is used for test bars in preference to the round section, because the latter is more apt to have serious cracks in the center, due to shrinkage, especially if the diameter is large. A round section, unless in very light hardware, is to be avoided, as the shrinkage crack in the center may have an outlet to the skin, and cause failure in service.

It is customary to provide for two sizes of test bars, the heavy and the light. Thus the 1-in. square bar represents work  $\frac{1}{2}$  an inch thick and over, and a  $1 \times \frac{1}{2}$ -in. section bar cares for the lighter castings. Both are 14 inches long. They should be cast at the beginning and at the end of each heat.

**Design of Malleable Castings.** — As white cast iron shrinks a great deal more than gray iron, and as the sections of malleable castings are lighter than those of similar castings of gray iron, fractures are very common. It is therefore the designer's aim to distribute the metal so as to meet these conditions. In long pieces the stiffening ribs should extend lengthways so as to produce as little resistance as possible to the contraction of the metal at the time of solidification. If this be not possible, the molder provides a "crush core" whose interior is filled with crushed coke. When the metal solidifies in the flask the core is crushed by the casting and thus prevents shrinkage cracks. At other times a certain corner or juncture of ribs in the casting will be found cracked. In order to prevent this a small piece of cast iron (chill) is embedded in the sand at this critical point, and the metal will cool here more quickly than elsewhere, and thus fortify this point, although it may happen that some other part of the casting will be found fractured instead, and in many cases the locations and the shape of strengthening ribs in the casting must be altered until a casting is procured free from shrinkage cracks. In designing of malleable cast-iron details the following rules should be observed:

(1) Endeavor to keep the metal in different parts of the casting at a uniform thickness. In a small casting, of, say, 10 lbs. weight,  $\frac{1}{4}$ -in. metal is about the practical thickness,  $\frac{5}{16}$  in. for a casting of 15 to 20 lbs., and  $\frac{3}{8}$  to  $\frac{1}{2}$  in. for castings of 40 lbs. and over. (2) Endeavor to avoid sharp junctions of ribs or parts, and if the casting is long, say 24 inches or more, the ends should be made of such shape as to offer as little resistance as possible to the contraction of metal when cooling in the mold.

**Specifications for Malleable Iron.** — The tensile strength of malleable iron varies with the thickness of the metal, the lighter sections having a greater strength per square inch than the heavier sections. An Eastern railroad designates the tensile strength desired as follows: Sections  $\frac{3}{8}$  in. thick or less should have a tensile strength of not less than 40,000 lbs. per sq. in.;  $\frac{3}{8}$  to  $\frac{3}{4}$  in. thick, not less than 38,000; and over  $\frac{3}{4}$  in., not less than 36,000 lbs. per sq. in. Test bars  $\frac{5}{8}$  and  $\frac{7}{8}$  in. diam. were made in the same mold and poured from the same ladle, and annealed together. The average tensile strength of five pairs of bars so treated, representing five heats, was,  $\frac{5}{8}$ -in. bars, 45,095;  $\frac{7}{8}$ -in. bars, 41,316 lbs. per sq. in. Average elongation in 6 in.:  $\frac{5}{8}$ -in. bars 5.3%;  $\frac{7}{8}$ -in. bars 4.2%.

A very high tensile strength can be obtained approaching that of cast steel but at the expense of the malleability of the product. Malleable test bars have been made with a tensile strength of between 60,000 and 70,000 lbs. per sq. in., but the ductility and ability to resist shocks of these bars was not equal to that of bars breaking at 40,000 to 45,000 pounds per sq. in.

The British Admiralty specification is 18 tons (40,320 lbs.) per square inch, a minimum elongation of  $4\frac{1}{2}\%$  in three inches and a



bending angle of at least 90° over a 1-in. radius, the bar being  $1 \times \frac{3}{8}$  in. in section.

A committee of the American Society for Testing Materials reported, in 1915, a set of specifications for malleable castings which includes the following: The specimen for tensile strength is a round bar 12 in. long,  $\frac{3}{4}$  in. diam. at the ends, tapering to a middle portion 4 in. long,  $\frac{5}{8}$  in. diam. The transverse test specimen is 14 in. long, 1 in. wide, and  $\frac{1}{2}$ ,  $\frac{5}{8}$ , or  $\frac{3}{4}$  in. thick, according to the thickness of the casting it represents. Specimens are to be cast without chills, with the ends free in the mold. The tensile strength shall be not less than 38,000 lb. per sq. in. with an elongation not less than 5% in 2 in. The transverse strength, the bar being tested with cope side up, on supports 12 in. apart, pressure being applied at the center shall be respectively 900, 1400, and 2000 lb. with deflections 1.25, 1.00, and 0.75 in the  $\frac{1}{2}$ ,  $\frac{5}{8}$ , and  $\frac{3}{4}$  in. test specimens. The specifications are intended to cover railroad malleable irons and the softer grades only. They include directions as to the casting of the test specimens and as to inspection.

**Improvement in Quality of Castings.** (Moldenke.)—The history of improvement in the malleable casting is admirably reflected in the test records of any works that has them. Going back to the early 90's, the average tensile strength of malleable cast iron was about 35,000 lbs. per sq. in., with an elongation of about 2% in 2 in. The transverse strength was perhaps 2800 lbs., with a deflection of  $\frac{1}{2}$  in. Toward the close of the 90's a fair average of the castings then made would run about 44,000 lbs. per sq. in., with an elongation of 5% in 2 in., and the transverse strength, about 3500 lbs., with a deflection of  $\frac{1}{2}$  inch. These average figures were greatly exceeded in establishments where special attention was given to the niceties of the process. The tensile strength here would run 52,000 lbs. per sq. in. regularly, with 7% elongation in 2 in., and the transverse strength, 5000 and over, with  $1\frac{1}{2}$  in. deflection.

**Further Progress Desirable.** (Moldenke.)—We do not know at the present time why cupola malleables require an annealing heat several hundred degrees higher than air or open-hearth furnace iron. The underlying principles of the oxidation of the bath, which is a frequent cause of defective iron, is practically unknown to the majority of those engaged in this industry. Heats are frequently made that will not pour nor anneal properly, but the causes are still being sought. To produce castings from successive heats, so that with the same composition they will have the same physical strength regardless of how they are tested, is a problem partially solved for steel, but not yet approached for malleable cast iron.

Sufficient progress in the study of iron with the microscope has been made to warrant the belief that in the not distant future we may be able to distinguish the constituents of the material by means of etching with various chemicals. When the sulphides and phosphides of iron, or the manganese-sulphur compounds, can be seen directly under the microscope, it is probable that a method may be found by which the dangerous ingredients may be so scattered or arranged that they will do the least harm.

The high sulphur in European malleable accounts to some extent for the comparatively low strength when contrasted with our product. Their castings being all very light, so long as they bend and twist properly, the purpose is served, and hence until heavier castings become the rule instead of the exception, "white heart" and steely-looking fractures will remain the characteristic feature of European work.

### STRENGTH OF MALLEABLE CAST IRON.

**Tests of Square Bars,**  $\frac{1}{2}$  in. and 1 in., by tension, compression and transverse stress, by M. H. Miner and F. E. Blake (*Railway Age*, Jan. 25, 1901).

**TENSION.** Six  $\frac{1}{2}$ -in. and six 1-in. round bars, also two 1-in. bars turned to remove the skin, from each of four makers. Average results:

T. S.,  $\frac{1}{2}$ -in. bars, 37,470–42,950, av. 40,960; E. L., 16,500–21,100, av. 19,176.

T. S., 1-in. bars, 35,750–40,530, av. 38,300; E. L., 14,860–19,900, av. 17,181.

Tensile strength, turned bars. av. 35,090: Elastic limit. av. 15,660.

Elong. in 8 in., 1/2-in. bars, 4.75 %; 1-in. bars, 4.32 %; turned bars, 3.73 %. Modulus of elasticity, 1/2-in. bars, 22,289,000; 1-in. bars, 21,677,000. COMPRESSION. 16 short blocks, 2 in. long, 1 in. and 1/2 in. square respectively.

8 long columns, 15 in. long, 1 in. sq., and 7.5 in. long, 1/2 in. sq. respectively.

Averages of blocks from each of four makers:

Short blocks, 1/2-in. sq., 93,000 to 114,500 lbs. per sq. in. Mean, 101,900 lbs. per sq. in.

Short blocks, 1 in. sq., 137,600 to 165,300 lbs. per sq. in. Mean, 152,800 lbs. per sq. in.

Ratio of final to original length, 1/2 in., 61.7 %; 1 in., 52.6 %. A small part of the shortening was due to sliding on the 45° plane of fracture.

Long columns: 1/2 in. × 7.5 in. Mean, 29,400 lbs. per sq. in.: 1 in. × 15 in., 27,500 lbs. per sq. in. Ratio of final to original length, 1/2 in., 98.5 %; 1 in., 98.8 %. The long columns did not rupture, but reached the maximum stress after bending into a permanent curve.

TRANSVERSE TESTS. Maximum fiber stress, mean of 8 tests, 1/2-in. bars, 34,163 lbs. per sq. in. 1-in. bars, 36,125 lbs. per sq. in. Length between supports, 20 in. The bars did not break, but failed by bending. The 1/2-in. bars could be bent nearly double.

Malleable Bars cast by Buhl Malleable Co., Detroit, Mich., tested as follows. The tests were reported by Chas. H. Day, *Am. Mach.*, April 5, 1906. The castings were all made at the same time. The rectangular sections were approximately 1/4 × 3/4 in. The star sections were square crosses, 1 in. wide, with arms about 1/4 in. thick. The figures here given are the maximum and minimum results from three bars of each section.

TENSILE TESTS.

COMPRESSION TESTS.

Section.	Area, sq. in.	Tensile St'gth, lbs. per sq. in.	Elong. in 8 in., %.	Red. of Area, %.	Area, sq. in.	L'gth, in.	Comp. Str., lbs. per sq. in.	Final Area, sq. in.
Round	0.817	43,000	5.87	4.76	0.847	15	31,700	0.901
"	0.801	43,400	6.21	3.98	0.801	15	33,240	0.886
"	0.219	41,130	7.70	3.40	0.209	7.5	32,600	0.221
"	0.202	44,700	13.00	3.63	0.204	7.5	34,600	0.215
Square	0.277	36,700	4.70	2.20	0.263	7.5	33,200	0.272
"	0.277	38,100	3.72	3.00	0.254	7.5	31,870	0.278
"	1.040	38,460	4.10	3.30	1.051	15	29,650	1.070
"	1.050	37,860	2.38	2.94	1.040	15	30,450	1.066
Rect.	0.239	31,200*	5.19	1.50	0.436	15	32,200	0.448
"	0.244	37,600	3.87	3.80	0.457	15	30,400	0.467
Star	0.584	34,600	4.20	3.10				
"	0.575	37,200	4.80	3.50				

\* Broke in flaw.

Tests of Rectangular Cast Bars, made by a committee of the Master Car-builders' Assn. in 1891 and 1892, gave the following results (selected to show range of variation):

Size of Section, in.	Tensile St'gth, lbs. per sq. in.	Elastic Limit, lbs. per sq. in.	Elongation, % in 4 in.	Size of Section, in.	Tensile St'gth, lbs. per sq. in.	Elastic Limit, lbs. per sq. in.	Elong. in 8 in., %.
0.25 × 1.52	34,700	21,100	2	0.29 × 2.78	28,160	22,650	0.6
0.5 × 1.53	32,800	17,000	2	0.39 × 2.82	32,060	20,595	1.5
0.78 × 2	25,100	15,400	1.5	0.53 × 2.76	27,875	19,520	1.1
0.88 × 1.54	33,600	19,300	1.5	0.8 × 2.76	25,120	18,390	1.1
1.52 × 1.54	28,200	.....	1.5	1.03 × 2.82	28,720	18,220	1.5

WROUGHT IRON.

The Manufacture of Wrought Iron. — When iron ore, which is an oxide of iron, Fe<sub>2</sub>O<sub>3</sub> or Fe<sub>3</sub>O<sub>4</sub>, containing silica, phosphorus, sulphur, etc., as impurities, is heated to a yellow heat in contact with charcoal or other fuel, the oxygen of the ore combines with the carbon of the fuel, part of the iron combines with silica to form a fusible cinder or slag, and the remainder of the iron agglutinates into a pasty mass which is intermingled with the cinder. Depending upon the time and the tempera-

ture of the operation, and on the kind and quality of the impurities present in the ore and the fuel, more or less of the sulphur and phosphorus may remain in the iron or may pass into the slag; a small amount of carbon may also be absorbed by the iron. By squeezing, hammering, or rolling the lump of iron while it is highly heated, the cinder may be nearly all expelled from it, but generally enough remains to give a bar after being rolled, cooled and broken across, the appearance of a fibrous structure. The quality of the finished bar depends upon the extent to which the chemical impurities and the intermingled slag have been removed from the iron.

The process above described is known as the direct process. It is now but little used, having been replaced by the indirect process known as puddling or boiling. In this process pig iron which has been melted in a reverberatory furnace is desiliconized and decarbonized by the oxygen derived from iron ore or iron scale in the bottom of the furnace, and from the oxidizing flame of the furnace. The temperature being too low to maintain the iron, when low in carbon, in a melted condition, it gradually "comes to nature" by the formation of pasty particles in the bath, which adhere to each other, until at length all the iron is decarbonized and becomes of a pasty condition, and the lumps so formed when gathered together make the "puddle-ball" which is consolidated into a bloom by the squeezer and then rolled into "muck-bar." By cutting the muck-bar into short lengths and making a "pile" of them, heating the pile to a welding heat and rerolling, a bar is made which is freer from cinder and more homogeneous than the original bar, and it may be further "refined" by another piling and rerolling. The quality of the iron depends on the quality of the pig-iron, on the extent of the decarbonization, on the extent of dephosphorization which has been effected in the furnace, on the greater or less contamination of the iron by sulphur derived from the fuel, and on the amount of work done on the piles to free the iron from slag. Iron insufficiently decarbonized is irregular, and hard or "steely." Iron thoroughly freed from impurities is soft and of low tensile strength. Iron high in sulphur is "hot-short," liable to break when being forged. Iron high in phosphorus is "cold-short," of low ductility when cold, and breaking with an apparently crystalline fracture.

See papers on Manufacture and Characteristics of Wrought Iron, by J. P. Roe, *Trans. A. I. M. E.*, xxxiii, p. 551; xxxvi, pp. 203, 807.

**Electrolytic Iron.** (L. Guillet, *Proc. Iron & Steel Inst.*, 1914, *Eng'g.*, Oct. 2, 1914.)—Using any pig iron in solution an iron can be obtained of the following average composition, after removal of the gases by annealing: C, 0.004; Si, 0.007; S, 0.006; P, 0.008. The metal deposited from the solution is extremely brittle and hard, due to occluded hydrogen. The deposition of the iron takes place on a revolving metal mandrel, making tubes of from 4 to 8 in. diam., 12.8 ft. long, 0.004 to 0.24 in. thick. After annealing, the metal becomes soft and ductile, with a tensile strength of from 44,000 to 47,000 lb. per sq. in. The industrial uses of electrolytic iron include the direct manufacture of tubes, sheets, rods for autogenous welding, and the preparation of raw material for the manufacture of steel. In localities where cheap electric current can be obtained the cost is estimated to be as low as \$30 to \$38 per gross ton. Patents on the process are owned by Compagnie Le Fer, Grenoble, France.

**Influence of Reduction in Rolling from Pile to Bar on the Strength of Wrought Iron.**—The tensile strength of the irons used in Beardslee's tests ranged from 46,000 to 62,700 lbs. per sq. in., brand L, which was really a steel, not being considered. Some specimens of L gave figures as high as 70,000 lbs. The amount of reduction of sectional area in rolling the bars has a notable influence on the strength and elastic limit; the greater the reduction from pile to bar, the higher the strength.

The following are a few figures from tests of one of the brands:

Size of bar, in. diam.:	4	3	2	1	1/2	1/4
Area of pile, sq. in.:	80	80	72	25	9	3
Bar per cent of pile:	15.7	8.83	4.36	3.14	2.17	1.6
Tensile strength, lb.:	46,322	47,761	48,280	51,128	52,275	59,585
Elastic limit, lb.:	23,430	26,400	31,892	36,467	39,126	—

**Influence of Chemical Composition on the Properties of Wrought Iron.** (Beardslee on Wrought Iron and Chain Cables. Abridgment by



W. Kent. Wiley & Sons, 1879.) — A series of 2000 tests of specimens from 14 brands of wrought iron, most of them of high repute, was made in 1877 by Capt. L. A. Beardslee, U.S.N., of the United States Testing Board. Forty-two chemical analyses were made of these irons, with a view to determine what influence the chemical composition had upon the strength, ductility, and welding power. From the report of these tests by A. L. Holley the following figures are taken:

Brand.	Average Tensile Strength.	Chemical Composition.					
		S.	P.	Si.	C.	Mn.	Slag.
L	66,598	trace	{ 0.065 0.084	0.080 0.105	0.212 0.512	0.005 0.029	0.192 0.452
P	54,363	{ 0.009 0.001	0.250 0.095	0.182 0.028	0.033 0.066	0.033 0.009	0.848 1.214
B	52,764	{ 0.008 0.003	0.231 0.140	0.156 0.182	0.015 0.027	0.017 trace	..... 0.678
J	51,754	{ 0.005 0.004	0.291 0.067	0.321 0.065	0.051 0.045	0.053 0.007	1.724 1.168
O	51,134	{ 0.005 0.007	0.078 0.169	0.073 0.154	0.042 0.042	0.005 0.021	0.974 .....

Where two analyses are given, they are the extremes of two or more analyses of the brand. Where one is given, it is the only analysis. Brand L should be classed as a puddled steel.

#### ORDER OF QUALITIES GRADED FROM NO. 1 TO NO. 19.

Brand.	Tensile Strength.	Reduction of Area.	Elongation.	Welding Power.
L	1	18	19	most imperfect.
P	6	6	3	badly.
B	12	16	15	best.
J	16	19	18	rather badly.
O	18	1	4	very good.
C	19	12	16	.....

The reduction of area varied from 54.2 to 25.9 per cent, and the elongation from 29.9 to 8.3 per cent.

Brand O, the purest iron of the series, ranked No. 18 in tensile strength, but was one of the most ductile; brand B, quite impure, was below the average both in strength and ductility, but was the best in welding power; P, also quite impure, was one of the best in every respect except welding, while L, the highest in strength, was not the most pure, it had the least ductility, and its welding power was most imperfect. The evidence of the influence of chemical composition upon quality, therefore, is quite contradictory and confusing. The irons differing remarkably in their mechanical properties, it was found that a much more marked influence upon their qualities was caused by different treatment in rolling than by differences in composition.

In regard to slag Mr. Holley says: "It appears that the smallest and most worked iron often has the most slag. It is hence reasonable to conclude that an iron may be dirty and yet thoroughly condensed."

In his summary of "What is learned from chemical analysis," he says: "So far, it may appear that little of use to the makers or users of wrought iron has been learned. . . . The character of steel can be surely predicated on the analyses of the materials; that of wrought iron is altered by subtle and unobserved causes."

**Specifications for Wrought Iron.** (F. H. Lewis, Engineers' Club of Philadelphia, 1891.) — 1. All wrought iron must be tough, ductile, fibrous, and of uniform quality for each class, straight, smooth, free from cinder-pockets, flaws, buckles, blisters, and injurious cracks along the edges, and must have a workmanlike finish. No specific process or provision of manufacture will be demanded, provided the material fulfills the requirements of these specifications.

2. The tensile strength, limit of elasticity, and ductility shall be determined from a standard test-piece not less than 1/4 inch thick, cut from the full-sized bar, and planed or turned parallel. The area of cross-

section shall not be less than  $\frac{1}{2}$  sq. in. The elongation shall be measured after breaking on an original length of 8 in.

3. The tests shall show not less than the following results:	El. in
	8 in.
For bar iron in tension..... T. S. = 50,000; E. L. = 26,000;	18%
For shape iron in tension..... " = 48,000; " = 26,000;	15%
For plates under 36 in. wide..... " = 48,000; " = 26,000;	12%
For plates over 36 in. wide..... " = 46,000; " = 25,000;	10%

4. When full-sized tension members are tested to prove the strength of their connections, a reduction in their ultimate strength of (500 X width of bar) pounds per square inch will be allowed.

5. All iron shall bend, cold, 180 degrees around a curve whose diameter is twice the thickness of piece for bar iron, and three times the thickness for plates and shapes.

6. Iron which is to be worked hot in the manufacture must be capable of bending sharply to a right angle at a working heat without sign of fracture.

7. Specimens of tensile iron upon being nicked on one side and bent shall show a fracture nearly all fibrous.

8. All rivet iron must be tough and soft, and be capable of bending cold until the sides are in close contact without sign of fracture on the convex side of the curve.

**Penna. R. R. Co.'s Specifications for Merchant-bar Iron (1904).**— One bar will be selected for test from each 100 bars in a pile.

All the iron of one size in the shipment will be rejected if the average tensile strength of the specimens tested full size as rolled falls below 47,000 lbs. or exceeds 53,000 lbs. per sq. in., or if a single specimen falls below 45,000 lbs. per sq. in.; or when the test specimen has been reduced by machining if the average tensile strength exceeds 53,000 or falls below 46,000, or if a single specimen falls below 44,000 lbs. per sq. in.

All the iron of one size in the shipment will be rejected if the average elongation in 8 in. falls below the following limits: Flats and rounds, tested as rolled,  $\frac{1}{2}$  in. and over, 20%; less than  $\frac{1}{2}$  in., 16%. Flats and rounds reduced by machining 16%.

*Nicking and Bending Tests.*— When necessary to make nicking and bending tests, the iron will be nicked lightly on one side and then broken by holding one end in a vise, or steam hammer, and breaking the iron by successive blows. It must when thus broken show a generally fibrous structure, not more than 25% crystalline, and must be free from admixture of steel.

**Stay-bolt Iron.** (Penna. R. R. Co.'s specifications, 1902).— Sample bars must show a tensile strength of not less than 48,000 lbs. per sq. in. and an elongation of not less than 25% in 8 in. One piece from each lot will be threaded in dies with a sharp V thread, 12 to 1 in. and firmly screwed through two holders having a clear space between them of 5 in. One holder will be rigidly secured to the bed of a suitable machine, and the other vibrated at right angles to the axis over a space of  $\frac{1}{4}$  in. or  $\frac{1}{8}$  in. each side of the center line. Acceptable iron should stand 2800 double vibrations before breakage.

Mr. Vauclain, of the Baldwin Locomotive Works, at a meeting of the American Railway Master Mechanics' Association, in 1892, says: Many advocate the softest iron in the market as the best for stay-bolts. He believed in an iron as hard as was consistent with heading the bolt nicely. The higher the tensile strength of the iron, the more vibrations it will stand, for it is not so easily strained beyond the yield-point. The Baldwin specifications for stay-bolt iron call for a tensile strength of 50,000 to 52,000 lbs. per square inch, the upper figure being preferred, and the lower being insisted upon as the minimum.

**Specifications for Wrought Iron for the World's Fair Buildings.** (*Eng'g News*, March 26, 1892.)— All iron to be used in the tensile members of open trusses, laterals, pins and bolts, except plate iron over 8 inches wide, and shaped iron, must show by the standard test-pieces a tensile strength in lbs. per square inch of:

$$52,000 - \frac{7000 \times \text{area of original bar in sq. in.}}{\text{circumference of original bar in inches}}$$

with an elastic limit not less than half the strength given by this formula. and an elongation of 20% in 8 in.





Cast iron appears to maintain its strength, with a tendency to increase, until 900° is reached, beyond which temperature the strength gradually diminishes. Under the highest temperatures, 1500° to 1600° F., numerous cracks on the cylindrical surface of the specimen were developed prior to rupture. It is remarkable that cast iron, so much inferior in strength to the steels at atmospheric temperature, under the highest temperatures has nearly the same strength the high-temper steels then have.

**Strength of Wrought Iron and Steel at High Temperatures.** (*Jour. F. I.*, cxii, 1881, p. 241.)—Kollmann's experiments at Oberhausen included tests of the tensile strength of iron and steel at temperatures ranging between 70° and 2000° F. Three kinds of metal were tested, viz., fibrous iron of 52,464 lbs. T. S., 38,280 lbs. E. L., and 17.5% elong.; fine-grained iron of 56,892 lbs. T. S., 39,113 lbs. E. L., and 20% elong.; and Bessemer steel of 84,826 lbs. T. S., 55,029 lbs. E. L., and 14.5% elong. The mean ultimate tensile strength of each material expressed in per cent of that at ordinary atmospheric temperature is given in the following table, the fifth column of which exhibits, for purposes of comparison, the results of experiments by a committee of the Franklin Institute in the years 1832-36.

Temperature Degrees F.	Fibrous Iron, %.	Fine-grained Iron, %.	Bessemer Steel, %.	Franklin Institute, %.
0	100.0	100.0	100.0	96.0
100	100.0	100.0	100.0	102.0
200	100.0	100.0	100.0	105.0
300	97.0	100.0	100.0	106.0
400	95.5	100.0	100.0	106.0
500	92.5	98.5	98.5	104.0
600	88.5	95.5	92.0	99.5
700	81.5	90.0	68.0	92.5
800	67.5	77.5	44.0	75.5
900	44.5	51.5	36.5	53.5
1000	26.0	36.0	31.0	36.0
1100	20.0	30.5	26.5	.....
1200	18.0	28.0	22.0	.....
1400	13.5	19.0	15.0	.....
1600	7.0	12.5	10.0	.....
1800	4.5	8.5	7.5	.....
2000	3.5	5.0	5.0	.....

**Effect of Cold on the Strength of Iron and Steel.**—The following conclusions were arrived at by Mr. Styffe in 1865:

(1) The absolute strength of iron and steel is not diminished by cold, even at the lowest temperature which ever occurs in Sweden.

(2) Neither in steel nor in iron is the extensibility less in severe cold than at the ordinary temperature.

(3) The limit of elasticity in both steel and iron lies higher in severe cold.

(4) The modulus of elasticity in both steel and iron is increased on reduction of temperature, and diminished on elevation of temperature; but that these variations never exceed 0.05% for a change of 1.8° F.

W. H. Barlow (*Proc. Inst. C. E.*) made experiments on bars of wrought iron, cast iron, malleable cast iron, Bessemer steel, and tool steel. The bars were tested with tensile and transverse strains, and also by impact; one-half of them at a temperature of 50° F., and the other half at 5° F.

The results of the experiments were summarized as follows:

1. When bars of wrought iron or steel were submitted to a tensile strain and broken, their strength was not affected by severe cold (5° F.), but their ductility was increased about 1% in iron and 3% in steel.

2. When bars of cast iron were submitted to a transverse strain at a low temperature, their strength was diminished about 3% and their flexibility about 16%.

3. When bars of wrought iron, malleable cast iron, steel, and ordinary cast iron were subjected to impact at 5° F., the force required to break them, and their flexibility, were reduced as follows:

	Reduction of Force of Impact, %.	Reduction of Flexibility, %.
Wrought iron, about.....	3	18
Steel (best cast tool), about.....	3 1/2	17
Malleable cast iron, about.....	4 1/2	15
Cast iron, about.....	21	not taken

The experience of railways in Russia, Canada, and other countries where the winter is severe, is that the breakages of rails and tires are far more numerous in the cold weather than in the summer. On this account a softer class of steel is employed in Russia for rails than is usual in more temperate climates.

The evidence extant in relation to this matter leaves no doubt that the capability of wrought iron or steel to resist impact is reduced by cold. On the other hand, its static strength is not impaired by low temperatures.

**Increased Strength of Steel at very Low Temperature.** — Steel of 72,300 lb. T. S. and 52,800 lb. elastic limit when tested at 76° F. gave 97,600 T. S. and 80,000 E. L. when tested at the temperature of liquid air. — Watertown Arsenal Tests, *Eng. Rec.*, July 21, 1906.

Prof. R. C. Carpenter (*Proc. A. A. A. S.* 1897) found that the strength of wrought iron at - 70° F. was 20% greater than at 70° F.

**Effect of Low Temperatures on Strength of Railroad Axles.** (Thos. Andrews, *Proc. Inst. C. E.*, 1891.) — Axles 6 ft. 6 in. long between centers of journals, total length 7 ft. 3 1/2 in., diameter at middle 4 1/2 in., at wheel-sets 5 1/8 in., journals 3 3/4 × 7 in., were tested by impact at temperatures of 0° and 100° F. Between the blows each axle was half turned over, and was also replaced for 15 minutes in the water-bath.

The mean force of concussion resulting from each impact was ascertained as follows:

Let  $h$  = height of free fall in feet,  $w$  = weight of test ball,  $hw = W$  = "energy," or work in foot-tons,  $x$  = extent of deflections between bearings

$$\text{then } F \text{ (mean force)} = W/x = hw/x .$$

The results of these experiments show that whereas at 0° F. a total average mean force of 179 tons was sufficient to cause the breaking of the axles, at 100° F. a total average mean force of 428 tons was required. In other words, the resistance to concussion of the axles at 0° F. was only about 42% of what it was at 100° F.

The average total deflection at 0° F. was 6.48 in., as against 15.06 in. with the axles at 100° F. under the conditions stated; this represents an ultimate reduction of flexibility, under the test of impact, of about 57% for the cold axles at 0° F., compared with the warm axles at 100° F.

**EXPANSION OF IRON AND STEEL BY HEAT.**

James E. Howard, engineer in charge of the U. S. testing-machine at Watertown, Mass., gives the following results of tests made on bars 35 in. long (*Iron Age*, April 10, 1890):

	C.			Coeffi. of Expansion per degree F.		C.			Coeffi. of Expansion per degree F.
	Mn.	Si.				Mn.	Si.		
Wrought iron.....	...	...	...	0.0000067302	Steel.....	0.57	0.93	.07	0.0000063891
Steel.....	0.09	0.11	...	.0000067561	".....	.71	.58	.08	.0000064716
".....	.20	.45	...	.0000066259	".....	.81	.56	.17	.0000062167
".....	.31	.57	...	.0000065149	".....	.89	.57	.19	.0000062335
".....	.37	.70	...	.0000066597	".....	.97	.80	.28	.0000061700
".....	.51	.58	.02	.0000066202	Cast (gun) iron.....	.....	.....	.....	.0000059261

**DURABILITY OF IRON, CORROSION, ETC.**

**Crystallization of Iron by Fatigue.** — Wrought iron of the best quality is very tough, and breaks, on being pulled in a testing machine or bent after nicking, with a fibrous fracture. Cold-short iron, however, is more brittle, and breaks square across the fibers with a fracture which is

commonly called crystalline although no real crystals are present. Iron which has been repeatedly overstrained, and especially iron subjected to repeated vibrations and shocks, also becomes brittle, and breaks with an apparently crystalline fracture. See "Resistance of Metals to Repeated Shocks," p. 276.

Walter H. Finley (*Am. Mach.*, April 27, 1905) relates a case of failures of  $1\frac{1}{8}$ -in. wrought-iron coupling pins on a train of 1-ton mine cars, apparently due to crystallization. After two pins were broken after a year's hard service, "several hitchings were laid on an anvil and the pin broken by a single blow from a sledge. Pieces of the broken pins were then heated to a bright red, and, after cooling slowly, were again put under the hammer, which failed entirely to break them. After cutting with a cleaver, the pins were broken, and the fracture showed a complete restoration of the fibrous structure. This annealing process was then applied to the whole supply of hitchings. Piles of twenty-five or thirty were covered by a hot wood fire, which was allowed to die down and go out, leaving the hitchings in a bed of ashes to cool off slowly. By repeating this every six months the danger of brittle pins was avoided."

**Durability of Cast Iron.** — Frederick Graff, in an article on the Philadelphia water-supply, says that the first cast-iron pipe used there was laid in 1820. These pipes were made of charcoal iron, and were in constant use for 53 years. They were uncoated, and the inside was well filled with tubercles. In salt water good cast iron, even uncoated, will last for a century at least; but it often becomes soft enough to be cut by a knife, as is shown in iron cannon taken up from the bottom of harbors after long submersion. Close-grained, hard white metal lasts the longest in sea water. (*Eng'g News*, April 23, 1887, and March 26, 1892.)

**Tests of Iron after Forty Years' Service.** — A square link 12 inches broad, 1 inch thick and about 12 feet long was taken from the Kieff bridge, then 40 years old, and tested in comparison with a similar link which had been preserved in the stock-house since the bridge was built. The following is the record of a mean of four longitudinal test-pieces,  $1 \times 1\frac{1}{8} \times 8$  inches, taken from each link (*Stahl und Eisen*, 1890):

Old Link . . . . .	T. S., 21.8 tons;	E. L., 11.1 tons;	Elong., 14.05%
New Link . . . . .	" 22.2 "	" 11.9 "	" 13.42%

**Durability of Iron in Bridges.** (G. Lindenthal, *Eng'g*, May 2, 1884, p. 139.) — The Old Monongahela suspension bridge in Pittsburg, built in 1845, was taken down in 1882. The wires of the cables were frequently strained to half of their ultimate strength, yet on testing them after 37 years' use they showed a tensile strength of from 72,700 to 100,000 lbs. per sq. in. The elastic limit was from 67,100 to 78,600 lbs. per sq. in. Reduction at point of fracture, 35% to 75%. Their diameter was 0.13 in.

A new ordinary telegraph wire of same gauge tested for comparison showed: T. S., of 100,000 lbs.; E. L., 81,550 lbs.; reduction, 57%. Iron rods used as stays or suspenders showed: T. S., 43,770 to 49,720 lbs. E. L., 26,380 to 29,200. Mr. Lindenthal draws these conclusions:

"The above tests indicate that iron highly strained for a long number of years, but still within the elastic limit, and exposed to slight vibration, will not deteriorate in quality.

"That if subjected to only one kind of strain it will not change its texture, even if strained beyond its elastic limit, for many years. It will stretch and behave much as in a testing-machine during a long test.

"That iron will change its texture only when exposed to alternate severe straining, as in bending in different directions. If the bending is slight but very rapid, as in violent vibrations, the effect is the same."

**Durability of Iron in Concrete.** — In Paris a sewer of reinforced concrete 40 years old was removed and the metal was found in a perfect state of preservation. In excavating for the foundations of the new General Post Office in London some old Roman brickwork had to be removed, and the hoop-iron bonds were still perfectly bright and good. (*Eng'g*, Aug. 16, 1907, p. 227.)

**Corrosion of Iron Bolts.** — On bridges over the Thames in London, bolts exposed to the action of the atmosphere and rain-water were eaten away in 25 years from a diameter of  $\frac{7}{8}$  in. to  $\frac{1}{2}$  in., and from  $\frac{5}{8}$  in. diameter to  $\frac{5}{16}$  in.

Wire ropes exposed to drip in colliery shafts are very liable to corrosion.

**Corrosive Agents in the Atmosphere.** — The experiments of F. Grace Calvert (*Chemical News*, March 3, 1871) show that carbonic acid,



in the presence of moisture, is the agent which determines the oxidation of iron in the atmosphere. He subjected perfectly cleaned blades of iron and steel to the action of different gases for a period of four months, with results as follows:

Dry oxygen, dry carbonic acid, a mixture of both gases, dry and damp oxygen and ammonia: no oxidation. Damp oxygen: in three experiments one blade only was slightly oxidized.

Damp carbonic acid: slight appearance of a white precipitate upon the iron, found to be carbonate of iron. Damp carbonic acid and oxygen: oxidation very rapid. Iron immersed in water containing carbonic acid oxidized rapidly.

Iron immersed in distilled water deprived of its gases by boiling rusted the iron in spots that were found to contain impurities.

**Sulphurous acid** (the product of the combustion of the sulphur in coal) is an exceedingly active corrosive agent, especially when the exposed iron is coated with soot. This accounts for the rapid corrosion of iron in railway bridges exposed to the smoke from locomotives. (See account of experiments by the author on action of sulphurous acid in *Jour. Frank. Inst.*, June, 1875, p. 437.) An analysis of sooty iron rust from a railway bridge showed the presence of sulphurous, sulphuric, and carbonic acids, chlorine, and ammonia. Bloxam states that ammonia is formed from the nitrogen of the air during the process of rusting.

**Galvanic Action** is a most active agent of corrosion. It takes place when two metals, one electro-negative to the other, are placed in contact and exposed to dampness.

**Corrosion in Steam-boilers.** — Internal corrosion may be due either to the use of water containing free acid, or water containing sulphate or chloride of magnesium, which decompose when heated, liberating the acid, or to water containing air or carbonic acid in solution. External corrosion rarely takes place when a boiler is kept hot, but when cold it is apt to corrode rapidly in those portions where it adjoins the brick-work or where it may be covered by dust or ashes, or wherever dampness may lodge. (See Impurities of Water, p. 720, and Incrustation and Corrosion, p. 927.)

**Corrosion of Iron and Steel.** — Experiments made at the Riverside Iron Works, Wheeling, W. Va., on the comparative liability to rust of iron and soft Bessemer steel: A piece of iron plate and a similar piece of steel, both clean and bright, were placed in a mixture of yellow loam and sand, with which had been thoroughly incorporated some carbonate of soda, nitrate of soda, ammonium chloride, and chloride of magnesium. The earth as prepared was kept moist. At the end of 33 days the pieces of metal were taken out, cleaned, and weighed, when the iron was found to have lost 0.84% of its weight and the steel 0.72%. The pieces were replaced and after 28 days weighed again, when the iron was found to have lost 2.06% of its original weight and the steel 1.79%. (*Eng'g*, June 26, 1891.)

**Internal Corrosion of Iron and Steel Pipes by Warm Water.** (T. N. Thomson, *Proc. A. S. H. V. E.*, 1908.) — Three short pieces of iron and three of steel pipes, 2 in. diam., were connected together by nipples and made part of a pipe line conveying water at a temperature varying from 160° to 212° F. In one year 9<sup>13</sup>/<sub>32</sub> lbs. of wrought iron lost 20<sup>3</sup>/<sub>4</sub> oz., and 9<sup>13</sup>/<sub>32</sub> lbs. of steel 24<sup>7</sup>/<sub>8</sub> oz. The pipes were sawed in two lengthwise, and the deepest pittings were measured by a micrometer. Assuming that the pitting would have continued at a uniform rate the wrought-iron pipes would have been corroded through in from 686 to 780 days, and the steel pipes from 760 to 850 days, the average being 742 days for iron and 797 days for steel. Two samples each of galvanized iron and steel pipe were also included in the pipe line, and their calculated life was: iron 770 and 1163 days; steel 619 and 1163 days. Of numerous samples of corroded pipe received from heating engineers ten had given out within four years of service, and of these six were steel and four were iron.

To ascertain whether Pipe is made of Wrought Iron or Steel, cut off a short piece of the pipe and suspend it in a solution of 9 parts of water, 3 of sulphuric acid, and 1 of hydrochloric acid in a porcelain or glass dish in such a way that the end will not touch the bottom of the dish. After 2 to 3 hours' immersion remove the pipe and wash off the acid. If the pipe is steel the end will present a bright, solid, unbroken surface, while if made of iron it will show faint ridges or rings, like the year rings in a

tree, showing the different layers of iron and streaks of cinder. In order that the scratches made by the cutting-off tool may not be mistaken for the cinder marks, file the end of the pipe straight across or grind on an emery wheel until the marks of the cutting-off tool have disappeared before putting it in the acid.

**Relative Corrosion of Wrought Iron and Steel.** (H. M. Howe, *Proc. A. S. T. M.*, 1906.)—On one hand we have the very general opinion that steel corrodes very much faster than wrought iron, an opinion held so widely and so strongly that it cannot be ignored. On the other hand we have the results of direct experiments by a great many observers, in different countries and under widely differing conditions; and these results tend to show that there is no very great difference between the corrosion of steel and wrought iron. Under certain conditions steel seems to rust a little faster than wrought iron, and under others wrought iron seems to rust a little faster than steel. Taking the tests in unconfined sea water as a whole wrought iron does constantly a little better than steel, and its advantage seems to be still greater in the case of boiling sea water. In the few tests in alkaline water wrought iron seems to have the advantage over steel, whereas in acidulated water steel seems to rust more slowly than wrought iron.

Steel which in the first few months may rust faster than wrought iron may, on greatly prolonging the experiments, or pushing them to destruction, actually rust more slowly, and *vice versa*.

Carelessly made steel, containing blowholes, may rust faster than wrought iron, yet carefully made steel, free from blowholes, may rust more slowly. Any difference between the two may be due not to the inherent and intrinsic nature of the material, but to defects to which it is subject if carelessly made. Care in manufacture, and special steps to lessen the tendency to rust, might well make steel less corrodible than wrought iron, even if steel carelessly made should really prove more corrodible than wrought iron.

For extensive discussions on this subject see *Trans. A. I. M. E.*, 1905. *Proc. A. S. T. M.*, 1906 and 1908, and Bulletins of National Tube Co.

**Corrosion of Fence Wire.** (A. S. Cushman, *Farmers' Bulletin*, No. 239, U. S. Dept. of Agriculture, 1905.)—"A large number of letters were received from all over the country in response to official inquiry, and all pointed in the same direction. As far as human testimony is capable of establishing a fact, there need be not the slightest question that modern steel does not serve the purpose as well as the older metal manufactured twenty or more years ago."

**Electrolytic Theory, and Prevention of Corrosion.** (A. S. Cushman, *Bulletin* No. 30, U. S. Dept. of Agriculture, Office of Public Roads, 1907. *The Corrosion of Iron*.)—The various kinds of merchantable iron and steel differ, within wide limits, in their resistance, not only to the ordinary processes of oxidation known as rusting, but also in other corrosive influences. Different specimens of one and the same kind of iron or steel will show great variability in resistance to corrosion under the conditions of use and service. The causes of this variability are numerous and complex, and the subject is not nearly so well understood at the present time as it should be. All investigators are agreed that iron cannot rust in air or oxygen unless water is present, and on the other hand it cannot rust in water unless oxygen is present.

From the standpoint of the modern theory of solutions, all reactions which take place in the wet way are attended with certain readjustments of the electrical states of the reacting ions. The electrolytic theory of rusting assumes that before iron can oxidize in the wet way it must first pass into solution as a ferrous ion.

Dr. Cushman then gives an account of his experiments which he considers demonstrate that iron goes into solution up to a certain maximum concentration in pure water, without the aid of oxygen, carbonic acid or other reacting substances. It is apparent that the rusting of iron is primarily due, not to attack by oxygen, but by hydrogen ions.

Solutions of chromic acid and potassium bichromate inhibit the rusting of iron. If a rod or strip of bright iron or steel is immersed for a few hours in a 5 to 10 per cent solution of potassium bichromate, and is then removed and thoroughly washed, a certain change has been produced on the surface of the metal. The surface may be thoroughly washed



and wiped with a clean cloth without disturbing this new surface condition. No visible change has been effected, for the polished surfaces examined under the microscope appear to be untouched. If, however, the polished strips are immersed in water it will be found that rusting is inhibited. An ordinary untreated polished specimen of steel will show rusting in a few minutes when immersed in the ordinary distilled water of the laboratory. Chromated specimens will stand immersion for varying lengths of time before rust appears. In some cases it is a matter of hours, in others of days or weeks before the inhibiting effect is overcome.

It would follow from the electrolytic theory that in order to have the highest resistance to corrosion a metal should either be as free as possible from certain impurities, such as manganese, or should be so homogeneous as not to retain localized positive and negative nodes for a long time without change. Under the first condition iron would seem to have the advantage over steel, but under the second much would depend upon care exercised in manufacture, whatever process was used.

There are two lines of advance by which we may hope to meet the difficulties attendant upon rapid corrosion. One is by the manufacture of better metal, and the other is by the use of inhibitors and protective coverings. Although it is true that laboratory tests are frequently unsuccessful in imitating the conditions in service, it nevertheless appears that chromic acid and its salts should under certain circumstances come into use to inhibit extremely rapid corrosion by electrolysis.

**Chrome Paints.**—G. B. Heckel (*Jour. F. I., Eng. Dig.*, Sept., 1908) quotes a letter from Mr. Cushman as follows: "My observation that chromic acid and certain of its compounds act as inhibitors has led to many experiments by other workers along the same line. I have found that the chrome compounds on the market vary very much in their action. Some of them show up as strong inhibitors, while others go to the opposite extreme and stimulate corrosion. Referring only to the labeled names of the pigments, I find among the good ones, in the order cited: Zinc chromate, American vermilion, chrome yellow orange, chrome yellow dd. Among the bad ones, also in the order given, I find: Chrome yellow medium, chrome green, chrome red. Much the worst of all is chrome yellow lemon. I presume that the difference is due to impurities that are present in the bad pigments."

Mr. Heckel suggests the following formula for a protective paint: 40 lbs. American vermilion, 10 lbs. red lead, 5 lbs. Venetian red. Zinc oxide and lamp-black to produce the required tint or shade. Grind in  $1\frac{1}{3}$  gal. of raw linseed oil — increasing the quantity as required for added zinc oxide or lamp-black — and  $\frac{1}{8}$  gal. crusher's drier. For use, thin with raw oil and very little turpentine or benzine.

He states that the substitution of zinc chrome for the American vermilion; of any high-grade finely ground iron oxide for the Venetian red; and of American vermilion for the red lead, would probably improve the protective value of the formula; that the addition of a very little kauri gum varnish, if zinc oxide is used, might be found advantageous; and that the substitution of a certain proportion of China wood oil for some of the linseed oil might improve the wearing qualities of the paint.

Dr. Cushman points out two dangers confronting us when we attempt to base an inhibitive formula on commercial products. The first is that all carbon pigments, excepting pure graphite, may contain sulphur compounds easily oxidizable to sulphuric acid when spread out as in a paint film. The second is the probability of variation in the composition of basic lead chromate or American vermilion. Because of these facts, it is necessary, before selecting any particular pigment for its inhibitive quality, to ascertain that it is free from acids or acid-forming impurities. As a result of his experiments he recommends the substitution of Prussian blue for the lamp-black in Mr. Heckel's formula, and lays down as a safe rule in the formulation of inhibitive paints, a careful avoidance of all potential stimulators of the hydrogen ions and consequently of any substance which might develop acid; preference being given to chromate pigments which are to some extent soluble in water, and to other pigments which in undergoing change tend to develop an alkaline rather than an acid reaction. Calcium sulphate, for example, in any form (as a constituent of Venetian red, for example), he deems dangerous to use because of the possibility of its developing acid. Barium sulphate, on the other hand, he regards as safe, because of its chemical stability.



**Corrosion caused by Stray Electric Currents.** (W. W. Churchill, *Science*, Sept. 28, 1906). — Surface condensers in electric lighting and other plants were abandoned on account of electrolytic corrosion. The voltage of the rails in the freight yard of the Long Island railroad at the peak of the load was 9 volts above the potential of the river, decreasing to 2 volts or less at light loads. This caused a destruction of water pipes and other things in the railroad yards. Experiments with various metal plates immersed in samples of East River water showed that it gave a more violent action than ordinary sea water. It was further observed that there was a local galvanic action going on, and that the amount of stray currents had something to do with the polarization of the surfaces, making the galvanic action exceedingly violent and destroying thin copper tubes at a very rapid rate. There was a violent local action between the zinc and the copper of the brass tubes which were in contact with the electrolyte, and this increased in the reaction as it progressed in stagnant conditions. By interposing a counter electromotive force against the galvanic couple which should exceed in pressure the voltage of the couple, the actions of the electrolytic corrosion ceased. When unconnected, or electrically separated, plates were placed in the electrolyte, if they were of composite construction and had sharp projections into the fluid, raised by cutting and prying up with a knife, they would have these projections promptly destroyed, and if an electric battery having a pressure exceeding that of the couple in the East River water was caused to act to produce a counter current, and having a pressure exceeding that of the galvanic couple (0.42 volt), the capacity of this electrolyte to drive off atoms of the mechanically combined metals in the alloys used was overcome and corrosion was arrested.

It, therefore, became desirable not only to carefully provide the balancing quantity of current to equal the stray traction currents arising from the ground returns of railway and other service, but to add to this the necessary voltage through a cathode placed in the circulating water in such a way as to bring to bear electrolytic action which would prevent the galvanic action due to this current coming into contact with alloys of mechanically combined metals such as the brass tubes (60% copper, 40% zinc).

In order to accomplish these two things, it was first necessary to so install the condensers as to prevent undue amounts of stray currents flowing through them, thus tending to reduce the amount of power required to prevent injurious action of these currents and otherwise to neutralize them. This was done by insulating the joints in the piping and from ground connections, and even lining the large water connections with glass melted on to the surface.

To furnish electromotive force, a 3-K.W. motor generator was provided. By means of a system of wiring, with ammeters and voltmeters, and a connection to an outlying anode in the condensing supply intake at its harbor end, this generator was planned to provide current to neutralize the stray currents in the condenser structure to any extent that they had passed the insulated joints in the supports and connections, as well as through the columns of water in the pipe connections, and then to adjust the additional voltage needed to counteract and prevent the galvanic action. All connections were made in a manner to insure a uniform voltage of the various parts of the condenser to prevent local action, each connection being so made and provided with such measuring instruments as to insure ready adjustment to effect this. The apparatus was designed in accordance with the above statements. Its operation has extended over fourteen months (to date, 1906), and with the exception of about ten tubes which have become pitted, the results have been satisfactory. The efficiency of the apparatus amply justifies the expense of its installation, while its operation is not expensive, and the plant described will be followed by other protecting plants of the same character.

**Electrolytic Corrosion due to Overstrain.** (C. F. Burgess, *El. Rev.*, Sept. 19, 1908.) — Mild steel bars overstrained in their middle portion were subjected to corrosion by suspension in dilute hydrochloric acid solutions, and others by making them the anode in neutral solutions of ammonium chloride and causing current to flow under low current density. In all cases a marked difference was noted in the rate at which the strained portions corroded as compared with the unstrained.

Differences of potential of from five to nine millivolts were noted between two electrodes, one of which constituted the strained portion and one the unstrained.

The more rapid electrolytic corrosion of the strained portion appears to be due to the fact that the strained metal is electropositive to the unstrained, the current finding the easier path through the surface of the electropositive metal. That the strained metal is the more electropositive is also shown by a liberation of hydrogen bubbles on the unstrained portion.

### PRESERVATIVE COATINGS.

The following notes have been furnished to the author by Prof. A. H. Sabin. (Revised, 1908.)

**Cement.** — Iron-work is often bedded in concrete; if free from cracks and voids it is an efficient protection. The metal should be cleaned and then washed with neat cement before embedding.

**Asphaltum.** — This is applied either by dipping (as water-pipe) or by pouring it on (as bridge floors). The asphalt should be slightly elastic when cold, with a high melting-point, not softening much at 100° F., applied at 300° to 400°; the surface must be dry and should be hot; the coating should be of considerable thickness.

**Paint.** — Composed of a vehicle or binder, usually linseed oil or some inferior substitute, or varnish (enamel paints); and a pigment, which is a more or less inert solid in the form of a powder, either mixed or ground together. Nearly all paint contains paint drier or japan, which is a lead or (and) manganese compound soluble in oil, and acts as a carrier of oxygen; as little should be used as possible. Boiled oil contains drier; no additional drier is needed. None should be used with varnish paints, nor with "ready-mixed paints" in general.

The principal pigments are white lead (carbonate or oxy-sulphate) and white zinc (oxide), red lead (peroxide), oxides of iron, hydrated and anhydrous, graphite, lampblack, bone black, chrome yellow, chrome green, ultramarine and Prussian blue, and various tinting colors. White lead has the greatest body or opacity of white pigments; three coats of it equal five of white zinc; zinc is more brilliant and permanent, but it is liable to peel, and it is customary to mix the two. These are the standard white paints for all uses, and the basis of all light-colored paints. Anhydrous iron oxides are brown and purplish brown, hydrated oxides are yellowish red to reddish yellow, with more or less brown; most iron oxides are mixtures of both sorts, and often contain a little manganese and much clay. They are cheap, and are serviceable paints on wood and are often used on iron, but for the latter use are falling into disrepute. Graphite used for painting iron contains from 10 to 90% foreign matter, usually silicates. It is very opaque, hence has great covering power and may be applied in a very thin coat, which is to be avoided. The best graphite paints give very good results. There are many grades of lampblack; the cheaper sorts contain oily matter and are especially hard to dry; all lampblack is slow to dry in oil. In a less degree this is true of all paints containing carbon, including graphite. Lampblack is used with advantage with red lead; it is also an ingredient of many "carbon" paints, the base of which is either bone black or artificial graphite. Red lead dries by uniting chemically with the oil to form a cement; it is heavy, and makes an expensive paint, and is often highly adulterated. Pure red lead has long had a high reputation as a paint for iron and steel, and is still used extensively, especially as a first coat; but of late years some of the new paints and varnish-like preparations have displaced it to a considerable extent even, on the most important work.

**Varnishes.** — These are made by melting fossil resin, to which is then added from half its weight to three times its weight of refined linseed oil, and the compound is thinned with turpentine; they usually contain a little drier. They are chiefly used on wood, being more durable and more brilliant than oil, and are often used over paint to preserve it. Asphaltum is sometimes substituted in part or in whole for the fossil resin, and in this way are made black varnishes which have been used on iron and steel with good results. Asphaltum and substances like it have

also been simply dissolved in solvents, as benzine or carbon disulphide, and used for the same purpose.

All these preservative coatings are supposed to form impervious films, keeping out air and moisture; but in fact all are somewhat porous. On this account it is necessary to have a film of appreciable thickness, best formed by successive coats, so that the pores of one will be closed by the next. The pigment is used to give an agreeable color, to help fill the pores of the oil film, to make the paint harder, so that it will resist abrasion, and to make a thicker film. In varnishes these results are sought to be attained by the resin which is dissolved in the oil. There is no sort of agreement among practical men as to which coating is best for any particular case; this is probably because so much depends on the preparation of the surface and the care with which the coating is applied, and also because the conditions of exposure vary so greatly.

**Methods of Application.** — From the surface of the metal mud and dirt must be first removed, then any rusty spots must be cleaned thoroughly; loose scale may be removed with wire brushes, but thick and closely adherent rust must be removed with steel scrapers, or with hammer and chisel if necessary. The sand-blast is used largely and increasingly to clean before painting, and is the best method known. Pickling is usually done with 10% sulphuric acid; the solution is made more active by heating. All traces of acid must be removed by washing, and the metal must be immediately dried and painted. Less than two coats of paint should never be used, and three or four are better. The first painting of metal is the most important. Paint is always thin on angles and edges, also on bolt and rivet heads; after the first full coat apply a partial or stripping coat, covering the angles and edges for at least an inch back from the edge, also all bolt and rivet heads. After this is dry apply the second full coat. At least a week should elapse between coats.

Cast-iron water pipes are usually coated by dipping in a hot mixture of coal-tar and coal-tar pitch; riveted steel pipes by dipping in hot asphalt or by a japan enamel which is baked on at about 400° F. Ships' bottoms are coated with a varnish paint to prevent rusting, over which is a similar paint containing a poison, as mercury chloride, or a copper compound, or else for this second coat a greasy copper soap is applied hot; this prevents the accumulation of marine growths. Galvanized iron and tin surfaces should be thoroughly cleaned with benzine and scrubbed before painting. When new they are partly covered with grease and chemicals used in coating the plates, and these must be removed or the paint will not adhere.

**Quantity of Paint for a Given Surface.** — One gallon of paint will cover 250 to 400 sq. ft. as a first coat, depending on the character of the surface, and from 350 to 500 sq. ft. as a second coat.

**Qualities of Paints.** — *The Railroad and Engineering Journal*, vols. liv. and lv., 1890 and 1891, has a series of articles on paint as applied to wooden structures, its chemical nature, application, adulteration, etc., by Dr. C. B. Dudley, chemist, and F. N. Pease, assistant chemist, of the Penna. R. R. They give the results of a long series of experiments on paints as applied to railway purposes.

**Inoxydation Processes.** (Contributed by Alfred Sang, Pittsburg, Pa., 1908.) — The black oxide of iron ( $Fe_3O_4$ ) as a continuous coating affords excellent protection against corrosion. Lavoisier (1781) noted its artificial production and its stable qualities. Faraday (1858) observed the protective properties of the coating formed by the action of steam in superheating tubes. Berthier discovered its formation by the action of highly heated air.

**Bower-Barff Process.** — Dr. Barff's method was to heat articles to be coated to about 1800° F. and inject steam heated to 1000° F. into the muffle. George and A. S. Bower used air instead of steam, then carbon monoxide (producer gas) to reduce the red oxide. In the combined process, the articles are heated to 1600° F. in a closed retort; superheated steam is injected for 20 min., then producer gas for 15 to 25 min.; the treatment can be repeated to increase the depth of oxidation. Less heat is required for wrought than for cast iron or steel. By a later improvement, steam heated above the temperature of the articles was injected during the last 1 to 2 hours. By a further improvement known as the "Wells Process," the work is finished in one operation, the steam



and producer-gas being injected together. Articles are slightly increased in size by the treatment. The surface is gray, changing to black when oiled; it will chip off if too thin; it will take paint or enamel and may be polished, but can not be either bent or machined; the coating itself is incorrodible and resists sea-water, mine-water and acid fumes; the strength of the metal is slightly reduced. The process is extensively used for small hardware. (See F. S. Barff, *Jour. I. & S. Inst.*, 1877, p. 356; A. S. Bower, *Trans. A. I. M. E.*, 1882, p. 329; B. H. Thwaite, *Proc. Inst. C. E.*, 1883, p. 255; George W. Maynard, *Trans. A. S. M. E.*, iv, 351.)

**Gesner Process.**—Dr. George W. Gesner's process is in commercial operation since 1890. The coating retort is kept at 1200° F. for 20 minutes after charging, then steam, partially decomposed by passing through a red-hot pipe, is allowed to act at intervals during 35 min.; finally, a small quantity of naphtha, or other hydrocarbon, is introduced and allowed to act for 15 min. The work is withdrawn when the heat has fallen to 800° F. The articles are neither increased in size nor distorted; the loss of strength and reduction of elongation are only slight. Large pieces can be treated. (See *Jour. I. & S. Inst.*, 1890 (ii), p. 850; *Iron Age*, 1890, p. 544.)

**Hydraesfer Process.**—An improvement of the Gesner process patented by J. J. Bradley and in commercial operation. As its name implies, the coating is thought to be an alloy of hydrogen, copper, and iron. The sulphides and phosphides are claimed to be burned out of the surface of the metal by the action of hydrogen at a high temperature giving additional rust-proof qualities. The appearance of the finished work is that of genuine Bower-Barffing.

**Russia and Planished Iron.**—Russia iron is made by cementation and slight oxidation. W. Dewees Wood (U. S. Pat. No. 252,166 of 1882) treated planished sheets with hydrocarbon vapors or gas and superheated steam within an air-tight and heated chamber.

**Niter Process.**—An old process improved by Col. A. R. Buffington in 1884. The articles are stirred about in a mixture of fused potassium nitrate (salt-peter) and manganese dioxide, then suspended in the vapors and finally dipped and washed in boiling water. Pure chemicals are essential. Used for small arms and pieces which cannot stand the high heat of other processes. (*Trans. A. S. M. E.*, vol. vi, p. 628.)

**Electric Process.**—A. de Meritens connected polished articles as anodes in a bath of warm distilled water and used a current as weak as could be conducted. A black film of oxide was formed; too strong a current produced rust. It being essential that hydrogen be occluded in the surface of the metal, it was found necessary, as a rule, to connect the articles as cathodes for a short time previous to inoxidation. (*Bull. Soc. Intle. des Electr.*, 1886, p. 230.)

**Aluminum Coatings.**—Aluminum can be deposited electrically, the main difficulties being the high voltage required and the readiness of the coating to redissolve. The metal-work of the tower of City Hall, Philadelphia, was coated by the Tacony Iron & Metal Co., Tacony, Pa., with 14 oz. per sq. ft. of copper, on which was deposited 2½ oz. of an alloy of tin and aluminum. The Reeves Mfg. Co., Canal Dover, Ohio, makes aluminum-coated conductor pipes, etc., said to be as durable as copper and as rust-proof as aluminum.

**Galvanizing** is a method of coating articles, usually of iron or steel, with zinc. Galvanized iron resists ordinary corroding agencies, the zinc becoming covered with a film of zinc carbonate, which protects the metal from further chemical action. The coating is, however, quickly destroyed by mine-water, tunnel gases, sea-water and conditions that commonly exist in tropical countries. If the work is badly done and the coating does not adhere properly, and if any acid from the pickle or any chloride from the flux remains on the iron, corrosion takes place under the zinc coating. (See M. P. Wood: *Trans. A. S. M. E.*, xvi, 350. Alfred Sang: *Trans. Am. Foundrymen's Assoc.*, 1907, *Iron Age*, May 23 and 30, 1907, and *Proc. Eng. Soc. of W. Penna.*, Nov., 1907.)

The Penna. R. R. Specifications for galvanized sheets for car roofs

(1907) prescribe that the black sheets before galvanizing should weigh 16 oz. per sq. ft., the galvanized sheet 18 oz. Sheets will not be accepted if a chemical determination shows less than 1.5 oz. of zinc per sq. ft.

**Hot Galvanizing.** — The articles to be galvanized are first cleaned by pickling and then dipped in a solution of hydrochloric acid and immersed in a bath of molten zinc at a temperature of from 800 to 900° F.; when they have reached the temperature of the bath, they are withdrawn and the coating is set in water; sal-ammoniac is used on the pot as a flux, either alone or as an emulsion with glycerine or some other fatty medium. Wire, bands and similar articles are drawn continuously through the bath, and may be passed through asbestos wipers to remove the surplus metal; in this case it is advisable to use a very soft spelter free from iron. If wire is treated slowly and passed through charcoal dust instead of wipers the product is known as "double-galvanized." Tin can be added to the bath to help bring out the spangles, but it gives a less durable coating. Aluminum is added as a Zn-Al alloy, with about 20% Al, to give fluidity. Sheets are galvanized continuously, and except in the case of so-called "flux sheets," are put through rolls as they emerge from the bath, to squeeze off the excess of zinc and improve the adherence.

**Test for Galvanized Wire.** — Sir W. Preece devised the following standard test for the British Post Office: dip for one minute in a saturated neutral solution of sulphate of copper, wash and wipe; to pass, the material must stand 3 dips.

The American standard test is as follows: prepare a neutral solution of sulphate of copper of sp. gr. 1.185, dip for one minute, wash and wipe dry; the wire must stand 4 dips without a permanent coating of copper showing on any part of the wire.

**Galvanizing by Cementation; Sherardizing.** — The alloying of metals at temperatures below their melting points has been known since 1820 or earlier. Berry (1838) invented a process of depositing zinc, in which the objects to be coated were placed in a closed retort and covered with a mixture of charcoal and powder of zinc; the retort was heated to cherry-red for a longer or shorter period, according to the bulk of the article and to the desired thickness of the coating. Dumas gave iron articles a slight coating of copper by dipping them in a solution of sulphate of copper and then heated them in a closed retort with oxide of zinc and charcoal dust. Sheet steel cowbells are coated with brass by placing them in a mixture of finely divided brass and charcoal dust and heating them to redness in an air-tight crucible.

S. Cowper-Coles's process, known as Sherardizing, patented in 1902, consists in packing the objects which are to be coated in zinc dust or pulverized zinc to which zinc oxide with a small percentage of charcoal dust is added, and heating in a closed retort to a temperature below the melting point of zinc. A large proportion of sand can be used to reduce the amount of zinc dust carried in the retort, to prevent caking and give a brighter finish; motion of the retort is in most cases necessary to obtain an even coating. The operation lasts from 30 minutes to several hours, depending on the size of the drum. Tempered steel is not affected by the process, but surfaces are hardened, there being a zinc-iron alloy formed to a depth varying with the time of treatment. This process is suitable for small work, giving a superior quality of zinc coating. (See Cowper-Coles, "Preservation and Ornamentation of Iron and Steel Surfaces," *Trans. Soc. Engrs.* 1905, p. 183; "Sherardizing," *Iron Age*, 1904, p. 12. Alfred Sang, "Theory and Practice of Sherardizing," *El. Chem. and Metall. Ind.*, May, 1907.)

**Lead Coatings.** — Lead is a good protection for iron and steel provided it is perfectly gas-tight. Electrically deposited lead does not bond well and the coating is porous. Sheets having a light coating of lead, produced by dipping in the molten metal, are known as *terne plates*; they have no lasting qualities. Lead-lined wrought pipe, fittings and valves are made for conveying acids and other corroding liquids.

## STEEL.

**The Manufacture of Steel.** (See Classification of Iron and Steel, p. 436.) Cast steel is a malleable alloy of iron, cast from a fluid mass. It is distinguished from cast iron, which is not malleable, by being much lower in carbon, and from wrought iron, which is welded from a pasty mass, by being free from intermingled slag. Blister steel is a highly carbonized wrought iron, made by the "cementation" process, which consists in keeping wrought-iron bars at a red heat for some days in contact with charcoal. Not over 2% of C is usually absorbed. The surface of the iron is covered with small blisters, supposedly due to the action of carbon on slag. Other wrought steels were formerly made by direct processes from iron ore, and by the puddling process from wrought iron, but these steels are now replaced by cast steels. Blister steel is, however, still used as a raw material in the manufacture of crucible steel. Case-hardening is a process of surface cementation.

**Crucible Steel** is commonly made in pots or crucibles holding about 80 pounds of metal. The raw material may be steel scrap; blister steel bars; wrought iron with charcoal; cast iron with wrought iron or with iron ore; or any mixture that will produce a metal having the desired chemical constitution. Manganese in some form is usually added to prevent oxidation of the iron. Some silicon is usually absorbed from the crucible, and carbon also if the crucible is made of graphite and clay. The crucible being covered, the steel is not affected by the oxygen or sulphur in the flame. The quality of crucible steel depends on the freedom from objectionable elements, such as phosphorus, in the mixture, on the complete removal of oxide, slag and blowholes by "dead-melting" or "killing" before pouring, and on the kind and quantity of different elements which are added in the mixture, or after melting, to give particular qualities to the steel, such as carbon, manganese, chromium, tungsten and vanadium.

**Bessemer Steel** is made by blowing air through a bath of melted pig iron. The oxygen of the air first burns away the silicon, then the carbon, and before the carbon is entirely burned away, begins to burn the iron. Spiegeleisen or ferro-manganese is then added to deoxidize the metal and to give it the amount of carbon desired in the finished steel. In the ordinary or "acid" Bessemer process the lining of the converter is a silicious material, which has no effect on phosphorus, and all the phosphorus in the pig iron remains in the steel. In the "basic" or Thomas and Gilchrist process the lining is of magnesian limestone, and limestone additions are made to the bath, so as to keep the slag basic, and the phosphorus enters the slag. By this process ores that were formerly unsuited to the manufacture of steel have been made available.

**Open-hearth Steel.** — Any mixture that may be used for making steel in a crucible may also be melted on the open hearth of a Siemens regenerative furnace, and may be desiliconized and decarbonized by the action of the flame and by additions of iron ore, deoxidized by the addition of spiegeleisen or ferro-manganese, and recarbonized by the same additions or by pig iron. In the most common form of the process pig iron and scrap steel are melted together on the hearth, and after the manganese has been added to the bath it is tapped into the ladle. In the Talbot process a large bath of melted material is kept in the furnace, melted pig iron, taken from a blast furnace, is added to it, and iron ore is added which contributes its iron to the melted metal while its oxygen decarbonizes the pig iron. When the decarbonization has proceeded far enough, ferro-manganese is added to destroy iron oxide, and a portion of the metal is tapped out, leaving the remainder to receive another charge of pig iron, and thus the process is continued indefinitely. In the Duplex Process melted cast iron is desiliconized in a Bessemer converter, and then run into an open hearth, where the steel-making operation is finished.

The open-hearth process, like the Bessemer, may be either acid or basic, according to the character of the lining. The basic process is a dephosphorizing one, and is the one most generally available, as it can use pig irons that are either low or high in phosphorus.



### Relation between the Chemical Composition and Physical Character of Steel.

W. R. Webster (*Trans. A. I. M. E.*, vols. xxi and xxii, 1893-4) gives results of several hundred analyses and tensile tests of basic Bessemer steel plates, and from a study of them draws conclusions as to the relation of chemical composition to strength, the chief of which are condensed as follows:

The indications are that a pure iron, without carbon, phosphorus, manganese, silicon, or sulphur, if it could be obtained, would have a tensile strength of 34,750 lbs. per sq. in., if tested in a  $\frac{3}{8}$ -in. plate. With this as a base, a table is constructed by adding the following hardening effects, as shown by increase of tensile strength, for the several elements named.

Carbon, a constant effect of 800 lbs. for each 0.01%.																					
Sulphur, " " 500 " " 0.01%.																					
Phosphorus, the effect is higher in high-carbon than in low-carbon steels.																					
With carbon hundredths %.....	9	10	11	12	13	14	15	16	17												
Each 0.01% P has an effect of lbs..	900	1000	1100	1200	1300	1400	1500	1500	1500												
Manganese, the effect decreases as the per cent of manganese increases.																					
Mn being per cent.....	.00	.15	.20	.25	.30	.35	.40	.45	.50	.55											
to	to	to	to	to	to	to	to	to	to	to											
Strength incr. for 0.01%...	240	240	220	200	180	160	140	120	100	100 lbs.											
Total increase from 0 Mn..	3600	4800	5900	6900	7800	8600	9300	9900	10,400	11,400											

Silicon is so low in this steel that its hardening effect has not been considered.

With the above additions for carbon and phosphorus the following table has been constructed (abridged from the original by Mr. Webster). To the figures given the additions for sulphur and manganese should be made as above.

#### Estimated Ultimate Strengths of Basic Bessemer-steel Plates.

For Carbon, 0.06 to 0.24; Phosphorus, .00 to .10; Manganese and Sulphur, .00 in all cases.

Carbon.	0.06	.08	.10	.12	.14	.16	.18	.20	.22	.24
Phos. .005	39,950	41,550	43,250	44,950	46,650	48,300	49,900	51,500	53,100	54,700
" .01	40,350	41,950	43,750	45,550	47,350	49,050	50,650	52,250	53,850	55,450
" .02	41,150	42,750	44,750	46,750	48,750	50,550	52,150	53,750	55,350	56,950
" .03	41,950	43,550	45,750	47,950	50,150	52,050	53,650	55,250	56,850	58,450
" .04	42,750	44,350	46,750	49,150	51,550	53,550	55,150	56,750	58,350	59,950
" .05	43,550	45,150	47,750	50,350	52,950	55,050	56,650	58,250	59,850	61,450
" .06	44,350	45,950	48,750	51,550	54,350	56,550	58,150	59,750	61,350	62,950
" .07	45,150	46,750	49,750	52,750	55,750	58,050	59,650	61,250	62,850	64,450
" .08	45,950	47,550	50,750	53,950	57,150	59,550	61,150	62,750	64,350	65,950
" .09	46,750	48,350	51,750	55,150	58,550	61,050	62,650	64,250	65,850	67,450
" .10	47,550	49,150	52,750	56,350	59,950	62,550	64,150	65,750	67,350	68,950
0.001 P. =	80 lbs.	80 lbs.	100 lb.	120 lb.	140 lb.	150 lb.	150 lb.	150 lb.	150 lb.	150 lb.

In all rolled steel the quality depends on the size of the bloom or ingot from which it is rolled, the work put on it, and the temperature at which it is finished, as well as the chemical composition.

The above table is based on tests of plates  $\frac{3}{8}$  inch thick and under 70 inches wide; for other plates Mr. Webster gives the following corrections for thickness and width. They are made necessary only by the effect of thickness and width on the finishing temperature in ordinary practice. Steel is frequently spoiled by being finished at too high a temperature.

Thickness, in. . . . .	3/4*	11/16	5/8	9/16	1/2	7/16	3/8	5/16
Correction (1) . . . . .	-2000	-1750	-1500	-1250	-1000	-500	0	+3000
Correction (2) . . . . .	-1000	-750	-500	-250	0	±500	+1000	+5000

\* And over. (1) Plates up to 70 in. wide. (2) Over 70 in. wide.

Comparing the actual result of tests of 408 plates with the calculated results, Mr. Webster found the variation to range as below.

Within lbs.	1000	2000	3000	4000	5000
Per cent. . . . .	28.4	55.1	74.7	89.9	94.9

The last figure would indicate that if specifications were drawn calling for steel plates not to vary more than 5000 lbs. T. S. from a specified figure (equal to a total range of 10,000 lbs.), there would be a probability of the rejection of 5% of the blooms rolled, even if the whole lot was made from steel of identical chemical analysis.

**Campbell's Formulæ.** (H. H. Campbell, *The Manufacture and Properties of Iron and Steel*, p. 387.) —

Acid steel, 40,000 + 1000 C + 1000 P + xMn = Ultimate strength.  
 Basic steel, 41,500 + 770 C + 1000 P + yMn = Ultimate strength.

The values of xMn and yMn are given by Mr. Campbell in a table, but they may be found from the formulæ xMn = 8 CMn - 320 C and yMn = 90 Mn + 4 CMn - 2700 - 120 C, or, combining the formulæ we have:

Ult. strength, acid steel, 40,000 + 680 C + 1000 P + 8 CMn.  
 " " basic " 38,800 + 650 C + 1000 P + 90 Mn + 4 CMn.

In these formulæ the unit of each chemical element is 0.01%.

Examples. Required the tensile strength of two steels containing respectively C, 0.10, P, 0.10, Mn, 0.30, and C, 0.20, P, 0.10, Mn, 0.65.

Answers, by Webster, 59,650 and 77,150; by Campbell, 57,700 and 72,850.

**Low Tensile Strength of Very Pure Steel.** — Swedish nail-rod open-hearth steel, tested by the author in 1881, showed a tensile strength of only 42,591 lbs. per sq. in. A piece of American nail-rod steel showed 45,021 lbs. per sq. in. Both steels contained about 0.10 C and 0.015 P, and were very low in S, Mn, and Si. The pieces tested were bars about 2 x 3/8 in. section.

R. A. Hadfield (*Jour. Iron and Steel Inst.*, 1894) gives the strength of very pure Swedish iron, remelted and tested as cast, 45,024 lbs. per sq. in.; remelted and forged, 47,040 lbs. The analysis of the cast bar was: C, 0.08; Si, 0.04; S, 0.02; P, 0.02; Mn, 0.01; Fe, 99.82.

**"Armco Ingot Iron."** — A very pure variety of open-hearth steel, made by the American Rolling Mill Co., Middletown, Ohio, has been given the trade name of Armco-American Ingot Iron. It is claimed for this product that it resists corrosion better than any other grade of wrought iron or steel. It is used chiefly in sheets. The tensile strength is given as 38,000 to 44,000 lb. per square inch; elastic limit one half the ultimate strength; elongation in 8 inches, 22%. The following analyses are given to show how Armco compares in composition with other iron products:

	S	P	C	Mn	Si	Cu	O	H	N	Fe
Armco. . . . .	.020	.003	.011	.019	.002	.025	.022	.001	.004	99.893
Puddled Iron. . . . .	.024	.155	.040	.040	.050	.025	.150	.001	.005	99.510
Mild Steel. . . . .	.050	.070	.115	.500	.005	.055	.023	.002	.009	99.171
High Carb. Steel. . . . .	.030	.030	1.000	.450	.150	.055	.025	.001	.006	98.253

**Effect of Oxygen upon Strength of Steel.** — A. Lantz, of the Peine works, Germany, in a letter to Mr. Webster, says that oxygen plays an important rôle — such that, given a like content of C, P, and Mn, a blow with greater oxygen content gives a greater hardness and less ductility than a blow with less oxygen content. The method used for determining oxygen is that of Prof. Ledebur, given in *Stahl und Eisen*, May, 1892, p. 193. The variation in O may make a difference in strength of nearly 1/2 ton per sq. in. (*Jour. I. and S. I.*, 1894.)

**Electric Conductivity of Steel.** — Louis Campredon reports in *Le Genie Civil* [prior to 1895] the results of experiments on the electric resistance of steel wires of different composition, ranging from 0.09 to 0.14 C; 0.21 to 0.54 Mn; Si, S, and P low. The figures show that the purer and



softer the steel the better is its electric conductivity, and, furthermore, that manganese is the element which most influences the conductivity. The results may be expressed by the formula  $R = 5.2 + 6.2S \pm 0.3$ ; in which  $R$  = relative resistance, copper being taken as 1, and  $S$  = the sum of the percentages of C, P, S, Si, and Mn. The conclusions are confirmed by J. A. Capp, in 1903, *Trans. A. I. M. E.*, vol. xxxiv, who made forty-five experiments on steel of a wide range of composition. His results may be expressed by the formula  $R = 5.5 + 4S \pm 1$ . High manganese increases the resistance at an increasing rate. Mr. Capp proposes the following specification for steel to make a satisfactory third rail, having a resistance eight times that of copper: C, 0.15; Mn, 0.30; P, 0.06; S, 0.06; Si, 0.05: none of these figures to be exceeded.

### Range of Variation in Strength of Bessemer and Open-Hearth Steels.

The Carnegie Steel Co. in 1888 published a list of 1057 tests of Bessemer and open-hearth steel from which the following figures are selected

Kind of Steel.	No. of Tests.	Elastic Limit.		Ultimate Strength.		Elongation, Per cent in 8 In.	
		High't.	Lowest.	High't.	Lowest.	High't.	Lowest.
(a) Bess. structural.	100	46,570	39,230	71,300	61,450	33.00	23.75
(b) " "	170	47,690	39,970	73,540	65,200	30.25	23.15
(c) " angles . . . .	72	41,890	32,630	63,450	56,130	34.30	26.25
(d) O. H. firebox . . .	25	.....	.....	62,790	50,350	36.00	25.62
(e) O. H. bridge . . .	20	.....	.....	69,940	63,970	30.00	22.75

### REQUIREMENTS OF SPECIFICATIONS.

- (a) E. L., 35,000; T. S., 62,000 to 70,000; elong., 22% in 8 in.
- (b) E. L., 40,000; T. S., 67,000 to 75,000.
- (c) E. L., 30,000; T. S., 56,000 to 64,000; elong., 20% in 8 in.
- (d) T. S., 50,000 to 62,000; elong., 26% in 4 in.
- (e) T. S., 64,000 to 70,000; elong., 20% in 8 in.

**Bending Tests of Steel.** (Pencoyd Iron Works.) — Steel below 0.10 C should be capable of doubling flat without fracture, after being chilled from a red heat in cold water. Steel of 0.15 C will occasionally submit to the same treatment, but will usually bend around a curve whose radius is equal to the thickness of the specimen; about 90% of specimens stand the latter bending test without fracture. As the steel becomes harder its ability to endure this bending test becomes more exceptional, and when the carbon becomes 0.20 little over 25% of specimens will stand the last-described bending test. Steel having about 0.40% C will usually harden sufficiently to cut soft iron and maintain an edge.

### EFFECT OF HEAT TREATMENT AND OF WORK ON STEEL.

**Low Strength Due to Insufficient Work.** (A. E. Hunt, *Trans. A. I. M. E.*, 1886.) — Soft steel ingots, made in the ordinary way for boiler plates, have only from 10,000 to 20,000 lbs. tensile strength per sq. in., an elongation of only about 10% in 8 in., and a reduction of area of less than 20%. Such ingots, properly heated and rolled down from 10 in. to 1/2 in. thickness, will give from 55,000 to 65,000 lbs. tensile strength, an elongation in 8 in. of from 23% to 33%, and a reduction of area of from 55% to 70%. Any work stopping short of the above reduction in thickness ordinarily yields intermediate results in tensile tests.

**Effect of Finishing Temperature in Rolling.** — The strength and ductility of steel depend to a high degree upon fineness of grain, and this may be obtained by having the temperature of the steel rather low, say at a dull red heat, 1300° to 1400° F., during the finishing stage of rolling. In the manufacture of steel rails a great improvement in quality has been obtained by finishing at a low temperature. An indication of the finishing temperature is the amount of shrinkage by cooling after leaving the rolls. The Phila. & Reading Railway Co.'s specification for rails (1902) says, "The temperature of the ingot or bloom shall be such that with rapid rolling and without holding before or in the finishing passes or subsequently, and without artificial cooling after leaving the



last pass, the distance between the hot saws shall not exceed 30 ft. 6 in. for a 30-ft. rail."

**Fining the Grain by Annealing.** — Steel which is coarse-grained on account of leaving the rolls at too high a temperature may be made fine-grained and have its ductility greatly increased without lowering its tensile strength by reheating to a cherry-red and cooling at once in air. (See paper on "Steel Rails," by Robert Job, *Trans. A. I. M. E.*, 1902.)

**Effect of Cold Rolling.** — Cold rolling of iron and steel increases the elastic limit and the ultimate strength, and decreases the ductility. Major Wade's experiments on bars rolled and polished cold by Lauth's process showed an average increase of load required to give a slight permanent set as follows: Transverse, 162%; torsion, 130%; compression, 161% on short columns 1½ in. long, and 64% on columns 8 in. long; tension, 95%. The hardness, as measured by the weight required to produce equal indentations, was increased 50%; and it was found that the hardness was as great in the center of the bars as elsewhere. Sir W. Fairbairn's experiments showed an increase in ultimate tensile strength of 50%, and a reduction in the elongation in 10 in. from 2 in. or 20% to 0.79 in. or 7.9%.

**Effect of Heat Treatment of a Motor-truck Axle.** — (John Younger, *Trans., A. S. M. E.*, 1915.) — Shafts 2¼ in. diam. whose analysis was approximately C, 0.20; Cr, 1.5; Mn, 0.30; Ni, 4.00; Si, 0.20; P and S below 0.04; elastic limit, 90,000; tensile strength, 105,000; reduction in area, 66%; elongation in 2 in., 25%, were found to break in service. The maximum power transmitted was about 33 H.P. at 27 r.p.m. Experiments were made with heat treatment to raise the elastic limit. The material selected had C, 0.30; Mn, 0.50; Cr, 1.5; Ni, 3.5. After heat treatment the elastic limit was 175,000 lb. per sq. in.; tensile strength, 185,000; elongation in 2 in., 14%; reduction of area, 53%. The shafts are machined from hot-rolled bars already heat-treated to show an elastic limit of about 100,000. They are then heated to between 1450° and 1500° F. and quenched in oil, then reheated to a little over 700° F. and cooled slowly in air. They warped slightly, but were straightened when hot under a press. The Brinell hardness after treatment was 402 to 444. Not one of the shafts thus treated has broken in service. Other steels, such as 5% nickel steels, chrome-vanadium steels, and air-hardening steels have been tried, and all have been standing up to service. The success seems to be due entirely to the high elastic limit. The Brinell hardness test is an unfailing indication of the success or non-success of the heat treatment.

**Effect of Annealing on Rolled Bars.** (Campbell, *Mfr. of Iron and Steel*, p. 275.)

Ultimate Strength.		Elastic Limit		Elong. in 8 in., %.		Red. Area, %.		Elas. Ratio.		
Natural.	Annealed.	Natural.	Annealed.	Natural.	Annealed.	Natural.	Annealed.	Natural.	Annealed.	
¾ in. rounds.	58,568	54,098	40,300	31,823	29.7	28.8	60.8	62.7	68.8	58.8
	62,187	58,364	42,606	35,120	28.0	28.6	62.2	63.5	68.5	60.2
	70,530	65,500	49,000	37,685	26.9	23.4	61.1	55.3	69.5	57.5
	76,616	69,402	51,108	40,505	24.5	23.0	53.7	56.5	66.7	58.4
2 × ¾ in. flats.	58,130	51,418	40,400	30,393	30.1	31.1	61.8	60.5	69.5	59.1
	62,089	55,021	42,441	31,576	30.1	30.4	60.9	60.0	68.4	57.4
	69,420	60,850	45,090	34,000	25.6	26.5	59.3	52.1	65.0	55.9
	75,865	67,618	49,691	39,403	24.7	26.3	54.4	51.4	65.5	58.3

The bars were rolled from 4 × 4-in. billets of open-hearth steel. The figures are averages of from 2 to 12 tests of each heat. In annealing the bars were heated in a muffle and withdrawn when they had reached a dull yellow heat.

**Hardening of Soft Steel.** — A. E. Hunt (*Trans. A. I. M. E.*, 1883, vol. xii) says that soft steel, no matter how low in carbon, will harden to a certain extent upon being heated red-hot and plunged into water, and that it hardens more when plunged into brine and less when quenched in oil.

A heat of open-hearth steel of 0.15% C and 0.29% Mn gave the following results upon test-pieces from the same ¼ in. thick plate,

Unhardened.....	T. S. 55,000	El. in 8 in.	27%	Red. of Area	62%
Hardened in water.....	" 74,000	"	25%	"	50%
Hardened in brine.....	" 84,000	"	22%	"	43%
Hardened in oil.....	" 67,000	"	26%	"	49%

The greatly increased tenacity after hardening indicates that there must be a considerable molecular change in the steel thus hardened, and that if such a hardening should be created locally in a steel plate, there must be very dangerous internal strains caused thereby.

**Comparative Tests of Full-sized Eye-bars and Small Samples.** (G. G. S. Morison, *A. S. C. E.*, 1893.)—17 full-sized eye-bars, of the steel used in the Memphis bridge, sections 10 in. wide  $\times$  1 to  $2\frac{3}{16}$  in. thick, and sample bars from the same melts. Average results:

Eye-bars: E. L., 32,350; T. S., 63,330; El. in full length, 13.7%; Red. of area, 36.3%.

Small bars: E. L., 40,650; T. S., 71,640; El. in 8 ins., 26.2%; Red. of area, 46.7%.

**"Recalescence" of Steel.**—If we heat a bar of copper by a flame of constant strength, and note carefully the interval of time occupied in passing from each degree to the next higher degree, we find that these intervals increase regularly, i.e., that the bar heats more and more slowly, as its temperature approaches that of the flame. If we substitute a bar of steel for one of copper, we find that these intervals increase regularly up to a certain point, when the rise of temperature is suddenly and in most cases greatly retarded or even completely arrested. After this the regular rise of temperature is resumed, though other like retardations may recur as the temperature rises farther. So if we cool a bar of steel slowly the fall of temperature is greatly retarded when it reaches a certain point in dull redness. If the steel contains much carbon, and if certain favoring conditions be maintained, the temperature, after descending regularly, suddenly rises spontaneously very abruptly, remains stationary a while and then redescends. This spontaneous reheating is known as "recalescence."

These retardations indicate that some change which absorbs or evolves heat occurs within the metal. A retardation while the temperature is rising points to a change which absorbs heat; a retardation during cooling points to some change which evolves heat. (Henry M. Howe, on "Heat Treatment of Steel," *Trans. A. I. M. E.*, vol. xxii.)

**Critical Point.** (Campbell, p. 287.)—If a piece of steel containing over 0.50 C be allowed to cool slowly from a high temperature the cooling at first proceeds at a uniformly retarded rate, but when about 700° C. is reached there is an interruption of this regularity. In some cases the rate of cooling may be very slow, in other cases the bar may not decrease in temperature at all, while in still other cases the bar may actually grow hotter for a moment. When this "critical point" is passed, the bar cools as before until it reaches the temperature of the atmosphere.

In metallography such a critical point is denoted by the letter A, and the particular one just described is known as Ar. In heating a piece of steel an opposite phenomenon is observed, there being an absorption of heat by internal molecular action, with a consequent retardation in the rise of temperature, and this point, which is some 30° C. higher than Ar, is called Ac.

In soft steels, below 0.30 C, three critical points are found in cooling a bar from a high temperature, called Ar<sub>3</sub>, Ar<sub>2</sub>, Ar<sub>1</sub>, Ar<sub>1</sub> being the lowest, and in heating the bar there are also three points, Ac<sub>1</sub>, Ac<sub>2</sub>, Ac<sub>3</sub>, the first named being the lowest. At each of the points there is a change in the micro-structure of the steel.

**Metallography.**—This is a name given to a study of the micro-structure of metals. The steel metallographist designates the different structures that are found in a polished and etched section by the names austenite, martensite, pearlite, cementite, ferrite, troostite, and sorbite. Austenite is produced by quenching steel of over 1.40 C in ice water from above 1050° C. Martensite is produced by quenching this steel from temperatures between 1050° C. and Ar<sub>1</sub>. It is also found together with cementite or ferrite in carbon steels below 1.30 C quenched at any point above Ar<sub>1</sub>. It is the constituent which confers hardness on steel. In steels cooled slowly to below Ar<sub>1</sub> the structure is composed entirely of ferrite, or entirely of pearlite, or of pearlite mixed with ferrite or cementite. Ferrite



is iron free from carbon and forms almost the whole of a low-carbon steel, while cementite is considered to be a compound of iron and carbon,  $Fe_3C$ , the C of this form being known as cement carbon. Pearlite is an intimate mixture of definite proportions of ferrite and cementite, corresponding to a pure steel of about 0.80 C, which, unhardened, consists of pearlite alone. Steels lower in C contain pearlite with ferrite, and steels higher in C contain pearlite and cementite. Troostite is a structure found when steel is quenched while cooling through the critical range, and sorbite when it is quenched at the end of the critical range. Quenching in lead or reheating quenched steel to a purple tint may also produce sorbite. (Campbell, p. 296.)

**Effect of Work on the Structure of Soft and Medium Steel.** — Steel as usually cast, cooling slowly, forms in crystals or grains. Rolling tends to break up this grain, but immediately after the cessation of work the formation of grains begins and continues until the metal has cooled to the lower critical point. Hence the lower the temperature to which the steel is worked, the more broken up the structure will be, but on the other hand if the rolling be continued below the critical point, the effect of cold work will be shown and strains will be set up which will make the piece unfit for use without annealing.

**Effect of Heat Treatment.** — In heating steel through the lowest critical point the crystalline structure is obliterated, the metal assuming the finest condition of which it is capable. Above this point the size of grain increases with the temperature.

**Effect of Heating on Crucible Steel.** (W. Campbell, *Proc. A. S. T. M.*, vi, 213.)—Six steels, containing carbon as follows: (1) 2.04, (2) 1.94, (3) 1.72, (4) 1.61, (5) 1.04, and (6) 0.70, were heated in a small gas furnace to the temperatures given in the table and allowed to cool slowly in the furnace, and were then tested, with results as below.

	As Rolled	650° C	715° C	760° C	800° C	855° C	905° C	950° C	1070° C	1200° C
(1) T. S...	144000	115400	114200	98800	95650	93800	95250	95200	99000	57400
E. L.....	104200	84600	83900	57700	57800	55500	55350	49350	49600	56000
El. in 2 in.	4.0	6.0	7.0	11.5	12.5	12.0	11.5	6.0	4.5	1.0
(2) T. S...	146400	115200	104100	95000	92000	89000	95350	91800	97000	61350
E. L.....	91000	91500	72600	68650	50500	51000	49450	49800	41750	47000
El. in 2 in.	6.3	8.0	9.5	15.0	17.0	12.5	7.0	9.5	8.5	2.0
(3) T. S...	153100	126000	114100	100300	98000	94000	94350	95000	92350	65300
E. L.....	98100	78300	75700	50500	48750	47900	48600	45200	43100	50600
El. in 2 in.	7.2	8.0	11.5	16.5	10.0	13.5	11.0	7.5	6.0	2.0
(4) T. S...	157700	128100	117000	98650	97700	95000	97350	96350	94400	69800
E. L.....	105200	85300	81300	52300	53350	51350	51350	48500	51400	.....
El. in 2 in.	6.5	.....	14.5	.....	18.5	15.0	11.5	7.5	3.5	3.0
(5) T. S...	141100	105400	97800	86800	96600	111800	115900	111500	106100	112600
E. L.....	75800	57700	55200	44850	46600	47200	50600	46800	56500	89600
El. in 2 in.	12.8	18.0	22.0	26.5	19.0	13.0	13.0	10.5	11.0	11.5
(6) T. S...	117000	95200	88700	85600	94300	91350	90300	90500	89500	90000
E. L.....	64700	53250	49700	40200	42150	42100	41400	39700	57350	58500
El. in 2 in.	17.0	23.0	27.5	27.0	19.0	18.5	18.0	16.5	18.0	16.0

The critical points  $Ar_1$  and  $Ac_1$  were determined, and the six steels gave practically identical results; thus  $Ar_1$  ranged from 696 to 708, averaging 704° C., and  $Ac_1$  ranged from 730 to 737, averaging 733° C.

The temperatures at which the finest-grained and a very coarse-grained fracture were found are as follows:

Steel No.....	1	2	3	4	5	6
Finest fracture.....	800	760	715-760	760	715	715° C
Very coarse fracture....	1070	1070	1070	1070	855	800° C

Mr. Campbell's paper gives a list of fourteen papers by different authorities on the micro-structure and the heat treatment of steel.

**Burning, Overheating, and Restoring Steel.** (G. B. Waterhouse, *A. S. T. M.*, vi, 247.)—Burnt metal is defined as coarsely crystalline and exceedingly brittle iron or steel, in consequence of excessive heating, often with some layers of oxide of iron. It cannot be effectively restored by heat treatment or mechanical work. Overheated metal is coarsely crystalline from excessive heating, but with no inter-crystalline spaces. It can be restored by heat treatment or mechanical work. Seven lots of



nickel steel bars, containing 3.8% Ni, and C as in the table, were heated to various temperatures in a muffle furnace, with results as below.

% C.	Heated to.....	1000a	1000b	1100b	1200b	1300b	1200c	1200d
0.41	T. S.....	90245	71800	71700	74000	71320	71487	74989
	El. % in 2 in.....	25.0	26.0	25.5	11.0	7.0	10.5	25.0
0.51	T. S.....	99109	78600	78800	84900	79600	81487	80795
	El. % in 2 in.....	21.0	25.0	24.0	11.5	5.0	15.5	22.5
0.63	T. S.....	115421	89000	89400	99600	85200	96040	89842
	El. % in 2 in.....	16.5	20.5	19.0	7.0	2.0	10.0	21.0
0.79	T. S.....	135194	108960	111840	109600	66800	102705	90214
	El. % in 2 in.....	14.0	15.0	14.0	3.0	0.5	6.0	21.0
0.97	T. S.....	156827	130336	138112	83117	46648	114107	103476
	El. % in 2 in.....	7.5	.....	3.5	0.5	0.0	5.5	18.0
1.24	T. S.....	168697	97510	98183	90729	60600	95103	106304
	El. in 2 in.....	3.5	15.0	1.0	0.5	0.0	1.5	3.5
1.48	T. S.....	145642	63950	66640	97894	35480	89045	74592
	El. in 2 in.....	10.5	23.6	25.0	8.0	1.0	17.5	24.0

a. Heated to 1000 C., which took 1 hr. 25 min., held there 25 min. and cooled in air. b. The time required to heat to the temperatures named was respectively 1 h. 10 m., 1 h. 45 m., 2 h. 35 m., and 2 h. 35 m. The bars were kept at the desired temperature for an hour and then cooled slowly in place. c. Reheated to 700 C. d. Reheated to 775 C.

In the steels below 1% C heating to 1200° is accompanied by an increase in ultimate strength and a drop in ductility. Heating above 1200° produces a very coarse crystallization and a great loss in strength and ductility. Reheating the overheated bars to 700° does not materially affect their structure, but reheating to 775° restores the structure nearly to that found before overheating, and completely restores the ductility. Similar results are found with carbon steel.

**Working Steel at a Blue Heat.**—Not only are wrought iron and steel much more brittle at a blue heat (i.e., the heat that would produce an oxide coating ranging from light straw to blue on bright steel, 430° to 600° F.), but while they are probably not seriously affected by simple exposure to blueness, even if prolonged, yet if they be worked in this range of temperature they remain extremely brittle after cooling, and may indeed be more brittle than when at blueness; this last point, however, is not certain. (Howe, *Metallurgy of Steel*, p. 534.)

Tests by Prof. Krohn, for the German State Railways, show that working at blue heat has a decided influence on all materials tested, the injury done being greater on wrought iron and harder steel than on the softer steel. The fact that wrought iron is injured by working at a blue heat was reported by Stromeier. (*Engineering News*, Jan. 9, 1892.)

A practice among boiler-makers for guarding against failures due to working at a blue heat consists in the cessation of work as soon as a plate which had been red-hot becomes so cool that the mark produced by rubbing a hammer-handle or other piece of wood will not glow. A plate which is not hot enough to produce this effect, yet too hot to be touched by the hand, is most probably blue hot, and should under no circumstances be hammered or bent. (C. E. Stromeier, *Proc. Inst. C. E.*, 1886.)

**Oil-tempering and Annealing of Steel Forgings.**—H. F. J. Porter says (1897) that all steel forgings above 0.1% carbon should be annealed, to relieve them of forging and annealing strains, and that the process of annealing reduces the elastic limit to 47% of the ultimate strength. Oil-tempering should only be practiced on thin sections, and large forgings should be hollow for the purpose. This process raises the elastic limit above 50% of the ultimate tensile strength, and in some alloys of steel, notably nickel steel, will bring it up to 60% of the ultimate.

**Heat Treatment of Armor Plates.** (Hadfield Process, *Iron Tr. Rev.*, Dec. 7, 1905.)—A cast armor plate of nickel-chromium steel is heated to from 950° C. to 1100° C., then cooled, preferably in air, then reheated to about 700° and cooled slowly, preferably in the furnace in which the heating was previously effected, again heated to about 700° and allowed to cool slowly to 640° C., whereupon it is suddenly cooled by spraying with water or by an air blast, but preferably in water. It is then reheated to about 600° and again suddenly cooled, preferably by quenching in water. Steel treated as described is suitable for armor plates and other articles including parts of safes. Satisfactory results

have been obtained by thus treating cast 6-in. armor plates containing about 0.3 to 0.4 C, 0.25 Mn, 1.8 Cr, and 3.3 Ni cast in a sand mold. Such a 6-in. plate attacked by armor-piercing projectiles of 4.7-in. and 6-in. calibers, stood over 15,000 foot-tons of energy without showing a crack. Also a 4-in. plate treated as described and having a carbonized or cemented face has withstood the attack of a 5.7-in. armor-piercing shell.

**Brittleness Due to Long-continued Heating.** If low-carbon steel, (say under 0.15%) is held for a very long time at temperatures between 500 and 750° C. (930 and 1380° F.), the crystals become enormous and the steel loses a large part of its strength and ductility. It takes a long time, in fact days, to produce this effect to any alarming degree, so that it is not liable to occur during manufacture or mechanical treatment, but steel is sometimes placed in positions where it may suffer this injury, for example, in the case of the tie-rods of furnaces, supports of boilers, etc., so that the danger should be borne in mind by all engineers and users of steel. A wrought-iron chain that supported one side of a 50-ton open-hearth ladle, which was heated many times to a temperature above 500° C., finally reached a condition of coarse crystallization, so that it was unable to bear the strain upon it. This phenomenon of coarse crystallization in low-carbon steel is known as "Stead's Brittleness," after J. E. Stead, who has explained its cause. The effect seems to begin at a temperature of about 500° C. and proceeds more rapidly with an increase in temperature until we reach 750° C. The damage may be repaired completely by heating the steel to a temperature between 800 and 900° C. The remedy is the same as that for coarse crystallization, due to overheating, and all steel which is placed in positions where it is liable to reach these temperatures frequently should be restored at intervals of a week or a month, or as often as may be necessary. (Stoughton.)

**Surface Decarburization of Steel Heated in Melted Salts.**—A. M. Portevin (*Proc. Iron & Steel Inst.*, 1914. *Eng'g*, Oct. 9, 1914) shows that the surface layer of steel, to a depth which varies with time and temperature, is greatly reduced in carbon when the steel is heated in a bath of molten alkaline salts. In a steel containing 0.78% C heated in melted potassium chloride at 900° C., the C at the surface was reduced in 1/4 hour to 0.5, in 2 hours to 0.3, and in 5 hours to 0.15, the thickness of the decarburized layer being for 1/4, 2, and 5 hours heating, respectively, 0.1, 0.2, and 0.3 mm. When cyanide and cyanate of potassium were added to the chloride decarburization and recarburization took place simultaneously, the percentage of carbon at the surface being 0.25 at the end of both 1/4 hour and 5 hours, the thickness of the decarburized layer increasing from 0.06 mm. to 0.69 mm.

#### **Influence of Annealing upon Magnetic Capacity.**

Prof. D. E. Hughes (*Eng'g*, Feb. 8, 1884, p. 130) has invented a "Magnetic Balance," for testing the condition of iron and steel, which consists chiefly of a delicate magnetic needle suspended over a graduated circular index, and a magnet coil for magnetizing the bar to be tested. He finds that the following laws hold with every variety of iron and steel:

1. The magnetic capacity is directly proportional to the softness, or molecular freedom.

2. The resistance to a feeble external magnetizing force is directly as the hardness, or molecular rigidity.

The magnetic balance shows that annealing not only produces softness in iron, and consequent molecular freedom, but it entirely frees it from all strains previously introduced by drawing or hammering. Thus a bar of iron drawn or hammered has a peculiar structure, say a fibrous one, which gives a greater mechanical strength in one direction than another. This bar, if thoroughly annealed at high temperatures, becomes homogeneous in all directions, and has no longer even traces of its previous strains, provided that there has been no actual separation into a distinct series of fibers.

### **TREATMENT OF STRUCTURAL STEEL.**

(James Christie, *Trans. A. S. C. E.*, 1893.)

**Effect of Punching and Shearing.** — The physical effects of punching and shearing as denoted by tensile test are for iron or steel:

Reduction of ductility; elevation of tensile strength at elastic limit; reduction of ultimate tensile strength.

In very thin material the disturbance described is less than in thick;

in fact, a degree of thinness is reached where this disturbance practically ceases. On the contrary, as thickness is increased the injury becomes more evident.

The effects described do not invariably ensue; for unknown reasons there are sometimes marked deviations from what seems to be a general result.

By thoroughly annealing sheared or punched steels the ductility is to a large extent restored and the exaggerated elastic limit reduced, the change being modified by the temperature of reheating and the method of cooling.

It is probable that the best results combined with least expenditure can be obtained by punching all holes where vital strains are not transferred by the rivets, and by reaming for important joints where strains on riveted joints are vital, or wherever perforation may reduce sections to a minimum. The reaming should be sufficient to thoroughly remove the material disturbed by punching; to accomplish this it is best to enlarge punched holes at least  $\frac{1}{8}$  in. diameter with the reamer.

**Riveting.** — It is the current practice to perforate holes  $\frac{1}{16}$  in. larger than the rivet diameter. For work to be reamed it is also a usual requirement to punch the holes from  $\frac{1}{8}$  to  $\frac{3}{16}$  in. less than the finished diameter, the holes being reamed to the proper size after the various parts are assembled.

It is also excellent practice to remove the sharp corner at both ends of the reamed holes, so that a fillet will be formed at the junction of the body and head of the finished rivets.

The rivets of either iron or mild steel should be heated to a bright red or yellow heat and subjected to a pressure of not less than 50 tons per square inch of sectional area.

For rivets of ordinary length this pressure has been found sufficient to completely fill the hole. If, however, the holes and the rivets are exceptionally long, a greater pressure and a slower movement of the closing tool than is used for shorter rivets has been found advantageous.

**Welding.** — No welding should be allowed on any steel that enters into structures. [See page 487.]

**Upsetting.** — Enlarged ends on tension bars for screw-threads, eye-bars, etc., are formed by upsetting the material. With proper treatment and a sufficient increment of enlarged sectional area over the body of the bar the result is entirely satisfactory. The upsetting process should be performed so that the properly heated metal is compelled to flow without folding or lapping.

**Annealing.** — The object of annealing structural steel is for the purpose of securing homogeneity of structure that is supposed to be impaired by unequal heating, or by the manipulation necessarily attendant on certain processes. The objects to be annealed should be heated throughout to a uniform temperature and uniformly cooled.

The physical effects of annealing, as indicated by tensile tests, depend on the grade of steel, or the amount of hardening elements associated with it; also on the temperature to which the steel is raised, and the method or rate of cooling the heated material.

The physical effects of annealing medium-grade steel, as indicated by tensile test, are reported very differently by different observers, some claiming directly opposite results from others. It is evident, when all the attendant conditions are considered, that the obtained results must vary both in kind and degree.

The temperatures employed will vary from 1000° to 1500° F. In some cases the heated steel is withdrawn at full temperature from the furnace and allowed to cool in the atmosphere; in others the mass is removed from the furnace, but covered under a muffle, to lessen the free radiation; or, again, the charge is retained in the furnace, and the whole mass cooled with the furnace, and more slowly than by either of the other methods.

The best general results from annealing will probably be obtained by introducing the material into a uniformly heated oven in which the temperature is not so high as to cause a possibility of cracking by sudden and unequal changing of temperature, then gradually raising the temperature of the material until it is uniformly about 1200° F., then withdrawing the material after the temperature is somewhat reduced and cooling under shelter of a muffle sufficiently to prevent too free and unequal cooling on the one hand or excessively slow cooling on the other.

G. G. Mehrtens, *Trans. A. S. C. E.*, 1893, says: "Annealing is of advan-



tage to all steel above 64,000 lbs. strength per square inch, but it is questionable whether it is necessary in softer steels. The distortions due to heating cause trouble in subsequent straightening, especially of thin plates.

"In a general way all unannealed mild steel for a strength of 56,000 to 64,000 lbs. may be worked in the same way as wrought iron. Rough treatment or working at a blue heat must, however, be prohibited. Shearing is to be avoided, except to prepare rough plates, which should afterwards be smoothed by machine tools or files before using. Drifting is also to be avoided, because the edges of the holes are thereby strained beyond the yield-point. Reaming drilled holes is not necessary, particularly when sharp drills are used and neat work is done. A slight counter-sinking of the edges of drilled holes is all that is necessary. Working the material while heated should be avoided as far as possible, and the engineer should bear this in mind when designing structures. Upsetting, cranking, and bending ought to be avoided, but when necessary the material should be annealed after completion.

"The riveting of a mild-steel rivet should be finished as quickly as possible, before it cools to the dangerous heat. For this reason machine work is the best. There is a special advantage in machine work from the fact that the pressure can be retained upon the rivet until it has cooled sufficiently to prevent elongation and the consequent loosening of the rivet."

**Punching and Drilling of Steel Plates.** (*Proc. Inst. M. E.*, Aug., 1887, p. 326.) — In Prof. Unwin's report the results of the greater number of the experiments made on iron and steel plates lead to the general conclusion that while thin plates, even of steel, do not suffer very much from punching, yet in those of 1/2 in. thickness and upwards the loss of tenacity due to punching ranges from 10% to 23% in iron plates and from 11% to 33% in the case of mild steel.

MISCELLANEOUS NOTES ON STEEL.

**May Carbon be Burned Out of Steel?** — Experiments made at the Laboratory of the Penna. Railroad Co. (Specifications for Springs, 1888) with the steel of spiral springs, show that the place from which the borings are taken for analysis has a very important influence on the amount of carbon found. If the sample is a piece of the round bar, and the borings are taken from the end of this piece, the carbon is always higher than if the borings are taken from the side of the piece. It is common to find a difference of 0.10% between the center and side of the bar, and in some cases the difference is as high as 0.23%. Apparently during the process of reducing the metal from the ingots to the round bar, with successive heatings, the carbon in the outside of the bar is burned out.

**Effect of Nicking a Steel Bar.** — The statement is sometimes made that, owing to the homogeneity of steel, a bar with a surface crack or nick in one of its edges is liable to fail by the gradual spreading of the nick, and thus break under a very much smaller load than a sound bar. With iron it is contended this does not occur, as this metal has a fibrous structure. Sir Benjamin Baker has, however, shown that this theory, at least so far as statical stress is concerned, is opposed to the facts, as he purposely made nicks in specimens of the mild steel used at the Forth Bridge, but found that the tensile strength of the whole was thus reduced by only about one ton per square inch of section. In an experiment by the Union Bridge Company a full-sized steel counter-bar, with a screw-turned buckle connection, was tested under a heavy statical stress, and at the same time a weight weighing 1040 lbs. was allowed to drop on it from various heights. The bar was first broken by ordinary statical strain, and showed a breaking stress of 66,800 lbs. per square inch. The longer of the broken parts was then placed in the machine and put under the following loads, whilst a weight, as already mentioned, was dropped on it from various heights at a distance of five feet from the sleeve-nut of the turn-buckle, as shown below:

Stress in pounds per sq. in.....	50,000	55,000	60,000	63,000	65,000
	ft. in.	ft. in.	ft. in.	ft. in.	ft. in.

The weight was then shifted so as to fall directly on the sleeve-nut, and the test proceeded as follows:

Stress on specimen in lbs. per square inch.....	65,350	65,350	68,800
Height of fall, feet.....	3	6	6

It will be seen that under this trial the bar carried more than when originally tested statically, showing that the nicking of the bar by screwing had not appreciably weakened its power of resisting shocks.—*Eng'g News*.

**Specific Gravity of Soft Steel.** (W. Kent, *Trans. A. I. M. E.*, xiv, 585.) — Five specimens of boiler-plate of C 0.14, P 0.03 gave an average sp. gr. of 7.932, maximum variation 0.008. The pieces were first planed to remove all possible scale indentations, then filed smooth, then cleaned in dilute sulphuric acid, and then boiled in distilled water, to remove all traces of air from the surface.

The figures of specific gravity thus obtained by careful experiment on bright, smooth pieces of steel are, however, too high for use in determining the weights of rolled plates for commercial purposes. The actual average thickness of these plates is always a little less than is shown by the calipers, on account of the oxide of iron on the surface, and because the surface is not perfectly smooth and regular. A number of experiments on commercial plates, and comparison of other authorities, led to the figure 7.854 as the average specific gravity of open-hearth boiler-plate steel. This figure is easily remembered as being the same figure with change of position of the decimal point (.7854) which expresses the relation of the area of a circle to that of its circumscribed square. Taking the weight of a cubic foot of water at 62° F. as 62.36 lbs. (average of several authorities), this figure gives 489.775 lbs. as the weight of a cubic foot of steel, or the even figure, 490 lbs., may be taken as a convenient figure, and accurate within the limits of the error of observation.

A common method of approximating the weight of iron plates is to consider them to weigh 40 lbs. per square foot one inch thick. Taking this weight and adding 2% gives almost exactly the weight of steel boiler-plate given above ( $40 \times 12 \times 1.02 = 489.6$  lbs. per cubic foot).

**Occasional Failures of Bessemer Steel.** — G. H. Clapp and A. E. Hunt, in their paper on "The Inspection of Materials of Construction in the United States" (*Trans. A. I. M. E.*, vol. xix), say: Numerous instances could be cited to show the unreliability of Bessemer steel for structural purposes. One of the most marked, however, was the following: A 12-in. I-beam weighing 30 lbs. to the foot, 20 feet long, on being unloaded from a car broke in two about 6 feet from one end.

The analyses and tensile tests made do not show any cause for the failure.

The cold and quench bending tests of both the original  $\frac{3}{4}$ -in. round test-pieces, and of pieces cut from the finished material, gave satisfactory results; the cold-bending tests closing down on themselves without sign of fracture.

Numerous other cases of angles and plates that were so hard in places as to break off short in punching, or, what was worse, to break the punches, have come under our observation, and although makers of Bessemer steel claim that this is just as likely to occur in open-hearth as in Bessemer steel, we have as yet never seen an instance of failure of this kind in open-hearth steel having a composition such as C 0.25%, Mn 0.70%, P 0.08%.

J. W. Wailes, in a paper read before the Chemical Section of the British Association for the Advancement of Science, in speaking of mysterious failures of steel, states that investigation shows that "these failures occur in steel of one class, viz., soft steel made by the Bessemer process."

**Dangerous Low Carbon Steel.**—A remarkable failure of ship-plate steel is described in *Jour. A. S. M. E.*, Jan., 1915 (from *Trans. North East Coast Institution of Engineers and Shipbuilders*). In punching the plates several of them cracked, and on riveting many of them cracked between the rivets; they also cracked on being struck with an ordinary hammer. The plates had passed all the usual chemical and physical tests of Lloyd's. A chemical analysis gave C. 0.05; Si. 0.08; Mn. 0.86; S. 0.08; P. 0.06. A micrographic examination showed numerous dove-gray areas of sulphide of manganese. Alternating stress tests on bars  $\frac{3}{8}$  in. diameter, bent  $\frac{3}{8}$  in. each way at 3 in. from the plane of maximum stress, gave only 100 alternations of stress before fracture, as compared with 300 for good steel. Prof. J. O. Arnold, of Sheffield, says the material appears to have been overheated in manufacturing the plates from the slab ingots, and that slow cooling from a high temperature after rolling, the plates being stacked in piles to cool, would make crystallization more perfect and hence more dangerous.

**Segregation in Steel Ingots.** (A. Pourcel, *Trans. A. I. M. E.*, 1893.)

— H. M. Howe, in his "Metallurgy of Steel," gives a *résumé* of observations, with the results of numerous analyses, bearing upon the phenomena of segregation.

A test-piece taken 24 inches from the head of an ingot 7.5 feet in length gave by analysis very different results from those of a test-piece taken 30 inches from the bottom.

	C.	Mn.	Si.	S.	P.
Top.....	0.92	0.535	0.043	0.161	0.261
Bottom.....	0.37	0.498	0.006	0.025	0.096

Segregation is less marked in ingots of extra-soft metal cast in cast-iron molds of considerable thickness. It is, however, still important, and explains the difference often shown by the results of tests on pieces taken from different portions of a plate. Two samples, taken from the sound part of a flat ingot, one on the outside and the other in the center, 7.9 inches from the upper edge, gave:

	C.	S.	P.	Mn.
Center.....	0.14	0.053	0.072	0.576
Exterior.....	0.11	0.036	0.027	0.610

Manganese is the element most uniformly disseminated in hard or soft steel.

For cannon of large caliber, if we reject, in addition to the part cast in sand and called the *masselotte* (sinking-head), one-third of the upper part of the ingot, we can obtain a tube practically homogeneous in composition, because the central part is naturally removed by the boring of the tube. With extra-soft steels, destined for ship- or boiler-plates, the solution for practically perfect homogeneity lies in the obtaining of a metal more closely deserving its name of extra-soft metal.

The injurious consequences of segregation must be suppressed by reducing, as far as possible, the elements subject to liquation.

**Segregation in Steel Plates.** (C. L. Huston, *Proc. A. S. T. M.*, vi, 182.)

A plate 370 × 76 × 5/16 in. was rolled from a 16 × 18-in. ingot, weighing 2800 lbs., the ladle test of which showed 0.18 C. Test pieces from the plate gave the following:

Top of Ingot:					
Tensile Strength.....	56,730	67,420	67,050	66,980	56,440
Carbon.....	0.13	0.25	0.27	0.25	0.13
Bottom of Ingot:					
Tensile Strength.....	56,120	57,720	58,400	58,140	56,900
Carbon.....	0.13	0.13	0.16	0.16	0.14
	1	2	3	4	5

Columns 1 and 5, edge of plate; 3, middle; 2 and 4, half way between middle and edge.

Other tests of low-carbon steel showed a lower degree of segregation. A plate from an ingot of 0.23 C gave minimum 0.18 C T. S., 64,580; maximum 0.38 C, T. S., 70,340. One from an ingot of 0.26 C gave maximum 0.20 C, T. S., 59,600; maximum 0.50 C, T. S., 78,600. (See also paper on this subject by H. M. Howe in vol. vii, p. 75.)

**Endurance of Steel under Repeated Alternate Stresses.** (J. E. Howard, *A. S. T. M.*, 1907, p. 252.)— Small bars were rapidly rotated in a machine while being subjected to a transverse strain. Two steels gave results as follows: (1) 0.55 C, T. S., 111,200; E. L., 59,000; Elong., 12%; Red. of area, 33.5%. (2) 0.82 C, T. S., 142,000; E. L., 64,000; Elong., 7%; Red. of area, 11.8%.

Fiber stress.....	60,000	50,000	45,000	40,000	35,000	30,000
No. of rotations before rupture.	(1) 12,490	33,160	166,240	455,000	900,000	76,326,240
	(2) 37,250	213,150	605,640	202,000,000	Not broken.	

**Welding of Steel.**— H. H. Campbell (*Manuf. of Iron and Steel*, p. 402) had numerous bars of steel welded by different skilled blacksmiths. The record of results, he says, "is extremely unsatisfactory." The worst weld by each of four workmen showed respectively 70, 54, 58, and 44% of the strength of the original bar. Forging steel showed one weld with only 48%, common soft steel 44%, and pure basic steel 59%. In a series of tests by the Royal Prussian Testing Institute, the average strength of welded bars of medium steel was 58% of the natural, the poorest bar showing only 23%. In softer steel the average was 71%.



and the poorest 33%, while in puddled iron the average was 81% and the poorest 62%. Mr. Campbell concludes: "A weld as performed by ordinary blacksmiths, whether on iron or steel, is not nearly as good as the rest of the bar; and it is still more certain that welds of large rods of common forging steel are unreliable and should not be employed in structural work. Electric methods do not offer a solution of the problem, for the metal is heated beyond the critical temperature of crystallization, and only by heavy reductions under the hammer or press can much be done towards restoring the ductility of the piece."

**Welding of Steel.**—A. E. Hunt (*A. I. M. E.*, 1892) says: "I have never seen so-called 'welded' pieces of steel pulled apart in a testing-machine or otherwise broken at the joint which have not shown a smooth cleavage plane, as it were, such as in iron would be condemned as an imperfect weld. My experience in this matter leads me to agree with the position taken by Mr. William Metcalf in his paper upon Steel (*Trans. A.S.C.E.*, vol. xvi, p. 301). Mr. Metcalf says, 'I do not believe steel can be welded'.

**The Thermit Welding Process.** (Goldschmidt Thermit Co., New York.)—When powdered or finely divided aluminum is mixed with a metallic oxide and ignited, the aluminum burns with great rapidity and intense heat, reducing the oxide to a metal and fusing it. It is said that iron oxide and aluminum will make a temperature of 5400° F., producing fused iron which will melt any iron or steel with which it comes in contact. The process is largely used for repairing breaks of large castings or forgings, such as the stern post of a steamship, a locomotive frame, etc. In the operation of welding a large fractured piece, the fracture is drilled out with a series of 3/4-in. holes close together, making a clear opening. A mold of fire-clay and sand is then made to fit all around the fracture, leaving a collar or ring surrounding it, baked in a furnace and then placed in position. The fractured section is then heated by a blow-torch inserted in the riser of the mold. A conical sheet iron crucible, lined with magnesia tar, is then inserted in the riser, and thermit (the mixture of aluminum and oxide of iron) poured into it. An ignition powder is placed on top of the thermit, and lighted with a storm match. The mixture begins to burn with great agitation; when this ceases the crucible is tapped, and white-hot fused iron or steel runs into the mold and thoroughly fuses with the pieces to be joined.

**Oxy-acetylene Welding and Cutting of Metals.**—**Autogenous Welding.**—By means of acetylene gas and oxygen, stored in tanks under pressure, and a properly constructed nozzle or torch in which the two gases are united and fired, an intense temperature said to be 6000° F., is generated, and it may be used to weld or fuse together iron, steel, aluminum, brass, copper, or other metals. The process of uniting metals by heat without using either flux or compression is called autogenous welding. The oxy-acetylene torch may also be used for cutting metals, such as steel plates, beams and large forgings, and for repairing flaws or defects, or filling cavities by melting a strip of metal and flowing it into place. The apparatus, with instruction in its use, is furnished by the Davis-Bournonville Co., Jersey City, N. J.

**Electric Welding.**—For description see Electrical Engineering.

**Hydraulic Forging.**—In the production of heavy forgings from cast ingots of mild steel it is essential that the mass of metal should be operated on as equally as possible throughout its entire thickness. When employing a steam-hammer for this purpose it has been found that the external surface of the ingot absorbs a large proportion of the sudden impact of the blow, and that a comparatively small effect only is produced on the central portions of the ingot, owing to the resistance offered by the inertia of the mass to the rapid motion of the falling hammer—a disadvantage that is entirely overcome by the slow, though powerful, compression of the hydraulic forging-press, which appears destined to supersede the steam-hammer for the production of massive steel forgings.

**Fluid-compressed Steel by the "Whitworth Process."** (*Proc. Inst. M. E.*, May, 1887, p. 167.)—In this system a gradually increasing pressure up to 6 or 8 tons per square inch is applied to the fluid ingot, and within half an hour or less after the application of the pressure the column of fluid steel is shortened 1 1/2 inches per foot or one-eighth of its length; the pressure is then kept on for several hours, the result being that the metal is compressed into a perfectly solid and homogeneous material free from blow holes.

In large gun-ring ingots during cooling the carbon is driven to the center, the center containing 0.8 carbon and the outer ring 0.3. The center is bored out until a test shows that the inside of the ring contains the same percentage of carbon as the outside.

Fluid-compressed steel is made by the Bethlehem Steel Co. for gun and other heavy forgings.

Putting sufficient pressure upon the outside of the ingot when the walls are solid but the interior is still liquid will prevent the formation of a pipe. In Whitworth's system the ingot is raised and compressed lengthwise against a solid ram situated above it, during and shortly after solidification. In Harmet's method the ingot is forced upward during solidification into its tapered mold. This causes a large radial pressure on its sides. In Lilienberg's method the ingots are stripped and then run on their cars between a solid and movable wall. The movable wall is then pressed against one side of the ingots. (Stoughton's Metallurgy of Iron and Steel.)

For other methods of compressing ingots see paper by A. J. Capron in *Jour. I. & S. I.*, 1906, *Iron Tr. Rev.*, May 24, 1906.

### STEEL CASTINGS.

(E. S. Cramp, Proc. Eng'g Congress, Dept. of Marine Eng'g, Chicago, 1893.)

In 1891 American steel-founders had successfully produced a considerable variety of heavy and difficult castings, of which the following are the most noteworthy specimens:

Bed-plates up to 24,000 lbs.; stern-posts up to 54,000 lbs.; stems up to 21,000 lbs.; hydraulic cylinders up to 11,000 lbs.; shaft-struts up to 32,000 lbs.; hawse-pipes up to 7500 lbs.; stern-pipes up to 8000 lbs.

The percentage of success in these classes of castings since 1890 has ranged from 65% in the more difficult forms to 90% in the simpler ones; the tensile strength has been from 62,000 to 78,000 lbs., elongation from 15% to 25%.

The first steel castings of which anything is generally known were crossing-frogs made for the Philadelphia & Reading R. R. in July, 1867, by the William Butcher Steel Works, now the Midvale Steel Co. The molds were made of a mixture of ground fire-brick, black-lead crucible-pots ground fine, and fire-clay, and washed with a black-lead wash. The steel was melted in crucibles, and was about as hard as tool steel. The surface of these castings was very smooth, but the interior was very much honey-combed. This was before the days when the use of silicon was known for solidifying steel. The sponginess, which was almost universal, was a great obstacle to their general adoption.

The next step was to leave the ground pots out of the molding mixture and to wash the mold with finely ground fire-brick. This was a great improvement, especially in very heavy castings; but this mixture still clung so strongly to the casting that only comparatively simple shapes could be made with certainty. A mold made of such a mixture became almost as hard as fire-brick, and was such an obstacle to the proper shrinkage of castings that, when at all complicated in shape, they had so great a tendency to crack as to make their successful manufacture almost impossible. By this time the use of silicon had been discovered, and the only obstacle in the way of making good castings was a suitable molding mixture. This was ultimately found in mixtures having the various kinds of silica sand as the principal constituent.

One of the most fertile sources of defects in castings is a bad design. Very intricate shapes can be cast successfully if they are so designed as to cool uniformly. Mr. Cramp says while he is not yet prepared to state that anything that can be cast successfully in iron can be cast in steel, indications seem to point that way in all cases where it is possible to put on suitable sinking-heads for feeding the casting.

H. L. Gantt (*Trans. A. S. M. E.*, xii, 710) says: Steel castings not only shrink much more than iron ones, but with less regularity. The amount of shrinkage varies with the composition and the heat of the metal; the hotter the metal the greater the shrinkage; and, as we get smoother castings from hot metal, it is better to make allowance for large shrinkage and pour the metal as hot as possible. Allow  $\frac{3}{16}$  or  $\frac{1}{4}$  in. per ft. in length for shrinkage, and  $\frac{1}{4}$  in. for finish on machined surfaces, except such as are cast "up." Cope surfaces which are to be machined should, in large or hard castings, have an allowance of from  $\frac{3}{8}$  to  $\frac{1}{2}$  in. for finish, as a large mass of metal

slowly rising in a mold is apt to become crusty on the surface, and such a crust is sure to be full of imperfections. On small, soft castings  $\frac{1}{8}$  in. on drag side and  $\frac{1}{4}$  in. on cope side will be sufficient. No core should have less than  $\frac{1}{4}$  in. finish on a side and very large ones should have as much as  $\frac{1}{2}$  in. on a side. Blow-holes can be entirely prevented in castings by the addition of manganese and silicon in sufficient quantities; but both of these cause brittleness, and it is the object of the conscientious steel-maker to put no more manganese and silicon in his steel than is just sufficient to make it solid. The best results are arrived at when all portions of the castings are of a uniform thickness, or very nearly so.

The following table will illustrate the effect of annealing on tensile strength and elongation of steel castings:

Carbon.	Tensile Strength.		Elongation.	
	Unannealed.	Annealed.	Unannealed.	Annealed.
0.23%	68,738	67,210	22.40%	31.40%
0.37	85,540	82,228	8.20	21.80%
0.53	90,121	106,415	2.35	9.80

The proper annealing of large castings takes nearly a week.

The proper steel for roll pinions, hammer dies, etc., seems to be that containing about 0.60% of carbon. Such castings, properly annealed, have worn well and seldom broken. Miscellaneous gearing should contain carbon 0.40% to 0.60%, gears larger in diameter being softest. General machinery castings should, as a rule, contain less than 0.40% of carbon, those exposed to great shocks containing as low as 0.20% of carbon. Such castings will give a tensile strength of from 60,000 to 80,000 lbs. per sq. in. and at least 15% extension in 2 in. Machinery and hull castings for war-vessels for the United States Navy, as well as carriages for naval guns, contain from 0.20% to 0.30% of carbon.

For description of methods of manufacture of steel castings by the Bessemer, open-hearth, and crucible processes, see paper by P. G. Salom, *Trans. A. I. M. E.*, xiv. 118.

### CRUCIBLE STEEL.

**Selection of Grades by the Eye, and Effect of Heat Treatment.** (J. W. Langley, *Amer. Chemist*, Nov., 1876.) — In the early days of steel making the grades were determined by inspection of the fractured surfaces of the cast ingots. The method of selection is described as follows:

The steel when thoroughly fluid is poured into cast-iron molds, and when cold the top of the ingot is broken off, exposing a freshly fractured surface. The appearance presented is that of confused groups of crystals, all appearing to have started from the outside and to have met in the center; this general form is common to all ingots of whatever composition, but to the trained eye, and only to one long and critically exercised, a minute but indescribable difference is perceived between varying samples of steel, and this difference is now known to be owing almost wholly to variations in the amount of combined carbon, as the following table will show. Twelve samples selected by the eye alone, and analyses of drillings taken direct from the ingot before it had been heated or hammered, gave results as below:

Ingot Nos.	1	2	3	4	5	6	7	8	9	10	11	12
C	0.302	.490	.529	.649	.801	.841	.867	.871	.955	1.005	1.058	1.079
Diff. of C		0.188	.039	.120	.152	.040	.026	.004	.084	.050	.053	.021

The C is seen to increase in quantity in the order of the numbers. The other elements, with the exception of total iron, bear no relation to the number on the samples. The mean difference of C is 0.071.

In mild steels the discrimination is less perfect.

The appearance of the fracture by which the above twelve selections were made can only be seen in the cold ingot before any operation, except the original one of casting, has been performed upon it. As soon as it is hammered, the structure changes, so that all trace of the primitive condition appears to be lost.

The specific gravity of steel is influenced not only by its chemical analysis but by the heat to which it is subjected.

The sp. gr. of the ingots in the above list ranged from 7.855 for No. 1



down to 7.803 for No. 12. Rolling into bars produced a very slight difference, — 0.005 in Nos. 5 and 6 and +0.020 in No. 12, but overheating reduced the sp. gr. of the bar 0.023 in No. 3 to 0.135 in No. 12, the sp. gr. of the burnt sample of No. 12 being only 7.690.

**Effect of Heat on the Grain of Steel.** (W. Metcalf, — Jeans on Steel, p. 642.) — A simple experiment will show the alteration produced in a high-carbon steel by different methods of hardening. If a bar of such steel be nicked at about 9 or 10 places, and about half an inch apart, a suitable specimen is obtained for the experiment. Place one end of the bar in a good fire, so that the first nicked piece is heated to whiteness, while the rest of the bar, being out of the fire, is heated up less and less as we approach the other end. As soon as the first piece is at a good white heat, which of course burns a high-carbon steel, and the temperature of the rest of the bar gradually passes down to a very dull red, the metal should be taken out of the fire and suddenly plunged in cold water, in which it should be left till quite cold. It should then be taken out and carefully dried. An examination with a file will show that the first piece has the greatest hardness, while the last piece is the softest, the intermediate pieces gradually passing from one condition to the other. On now breaking off the pieces at each nick it will be seen that very considerable and characteristic changes have been produced in the appearance of the metal. The first burnt piece is very open or crystalline in fracture; the succeeding pieces become closer and closer in the grain until one piece is found to possess that perfectly even grain and velvet-like appearance which is so much prized by experienced steel users. The first pieces also, which have been too much hardened, will probably be cracked; those at the other end will not be hardened through. Hence if it be desired to make the steel hard and strong, the temperature used must be high enough to harden the metal through, but not sufficient to open the grain.

**Heating Tool Steel.** (Crescent Steel Co., Pittsburg, Pa.) — There are three distinct stages or times of heating: First, for forging; second, for hardening; third, for tempering.

The first requisite for a good heat for forging is a clean fire and plenty of fuel, so that jets of hot air will not strike the corners of the piece; next, the fire should be regular, and give a good uniform heat to the whole part to be forged. It should be keen enough to heat the piece as rapidly as may be, and allow it to be thoroughly heated through, without being so fierce as to overheat the corners. Steel should not be left in the fire any longer than is necessary to heat it clear through, as "soaking" in fire is injurious; on the other hand, it is necessary that it should be hot through, to prevent surface cracks. By observing these precautions a piece of steel may always be heated safely, up to even a bright yellow heat, when there is much forging to be done on it.

The best and most economical of welding fluxes is clean, crude borax, which should be first thoroughly melted and then ground to fine powder.

After the steel is properly heated, it should be forged to shape as quickly as possible; and just as the red heat is leaving the parts intended for cutting edges, these parts should be refined by rapid, light blows, continued until the red disappears.

For the second stage of heating, for hardening, great care should be used: first, to protect the cutting edges and working parts from heating more rapidly than the body of the piece; next, that the whole part to be hardened be heated uniformly through, without any part becoming visibly hotter than the other. A uniform heat, as low as will give the required hardness, is the best for hardening.

For every variation of heat which is great enough to be seen there will result a variation in grain, which may be seen by breaking the piece; and for every such variation in temperature there is a very good chance for a crack to be seen. Many a costly tool is ruined by inattention to this point.

The effect of too high heat is to open the grain; to make the steel coarse. The effect of an irregular heat is to cause irregular grain, irregular strains, and cracks.

As soon as the piece is properly heated for hardening, it should be promptly and thoroughly quenched in plenty of the cooling medium, water, brine, or oil, as the case may be. An abundance of cooling bath, to do the work quickly and uniformly all over, is necessary to good and safe work.

To harden a large piece safely a running stream should be used.

Much uneven hardening is caused by the use of too small baths.

For the third stage of heating, to temper, the first important requisite is again uniformity. The next is time; the more slowly a piece is brought down to its temper, the better and safer is the operation.

When expensive tools are to be made it is a wise precaution to try small pieces of the steel at different temperatures, so as to find out how low a heat will give the necessary hardness. The lowest heat is the best for any steel. [This is true of carbon steel but not of "high speed" alloy steels.]

**Heating in a Lead Bath.** — A good method of heating steel to a uniform temperature is by means of a bath of lead kept at a red heat by a gas furnace. See Heat Treatment by the Taylor-White Process, under Machine Shop.

**Heating Steel in Melted Salts by Electric Current.** — L. M. Cohn (*Electrot. Z.*, Aug., 1906, *Mach'y*, Dec., 1906) describes a furnace patented by Gebr. Körting, Berlin, in which steel may be heated uniformly to any desired temperature up to 1300° C. (2372° F.) without danger of oxidizing.

The furnace consists mainly of a cast-iron box, lined inside with fire-clay, a second lining of fire-bricks, lined again with asbestos, and inclosing the crucible made of one piece of fireproof material. Two electrodes lead into the crucible, through which alternating current is sent. The crucible is filled with metal salts. For temperatures above 1000° C. pure chloride of barium is used, the melting-point of which is at about 950° C. (1742 F.): for lower temperatures a mixture of chloride of barium and chloride of potassium, 2 to 1, is used, melting at about 670° C. (1238 F.). Any other suitable salts may be used. A regulating transformer regulates the current, and thus also the temperature.

A test was made with a furnace, the bath of which was  $6\frac{1}{2} \times 6\frac{1}{2} \times 7$  in. A 50-period alternating current of 190-volt primary tension was used. This tension had to be reduced to from 50 to 55 volts by the regulating transformer for starting the furnace, and lowered later on. The heating lasted about half an hour. For temperatures from 750 to 1300° C., the secondary tension amounted to from 13 to 18 volts. The consumption of energy was as follows: 880° C., 5.4 Kw.; 1140° C., 8.5 Kw.; 1300° C., 12.25 Kw. A milling cutter 5 in. diam.,  $1\frac{1}{4}$  in. bore, 1 in. thick, was heated in 62 seconds to 1300° C. A bushing of tool steel  $2\frac{3}{4}$  in. diam.,  $2\frac{3}{4}$  in. long,  $\frac{5}{8}$  in. bore, was heated in 243 seconds to 850° C.

**Heating to Forge.** (Crescent Steel Co.) — The trouble in the forge fire is usually uneven heat, and not too high heat. Suppose the piece to be forged has been put into a very hot fire, and forced as quickly as possible to a high yellow heat, so that it is almost up to the scintillating point. If this be done, in a few minutes the outside will be quite soft and in a nice condition for forging, while the middle parts will not be more than red-hot. Now let the piece be placed under the hammer and forged, and the soft outside will yield so much more readily than the hard inside, that the outer particles will be torn asunder, while the inside will remain sound.

Suppose the case to be reversed and the inside to be much hotter than the outside; that is, that the inside shall be in a state of semi-fusion, while the outside is hard and firm. Now let the piece be forged, and the outside will be all sound and the whole piece will appear perfectly good until it is cropped, and then it is found to be hollow inside.

In either case, if the piece had been heated soft all through, or if it had been only red-hot all through, it would have forged perfectly sound.

In some cases a high heat is more desirable to save heavy labor, but in every case where a fine steel is to be used for cutting purposes it must be borne in mind that very heavy forging refines the bars as they slowly cool, and if the smith heats such refined bars until they are soft, he raises the grain, makes them coarse, and he cannot get them fine again unless he has a very heavy steam-hammer at command and knows how to use it well.

**Annealing.** (Crescent Steel Co.) — Annealing or softening is accomplished by heating steel to a red heat and then cooling it very slowly, to prevent it from getting hard again.

The higher the degree of heat, the more will steel be softened, until the limit of softness is reached, when the steel is melted.

It does not follow that the higher a piece of steel is heated the softer it will be when cooled, no matter how slowly it may be cooled; this is proved by the fact that an ingot is always harder than a rolled or hammered bar made from it.

Therefore there is nothing gained by heating a piece of steel hotter than

a good, bright, cherry-red; on the contrary, a higher heat has several disadvantages: First. If carried too far, it may leave the steel actually harder than a good red heat would leave it. Second. If a scale is raised on the steel, this scale will be harsh, granular oxide of iron, and will spoil the tools used to cut it. Third. A high scaling heat continued for a little time changes the structure of the steel, makes it brittle, liable to crack in hardening, and impossible to refine.

To anneal any piece of steel, heat it red-hot; heat it uniformly and heat it through, taking care not to let the ends and corners get too hot. As soon as it is hot, take it out of the fire, the sooner the better, and cool it as slowly as possible. A good rule for heating is to heat it at so low a red that when the piece is cold it will still show the blue gloss of the oxide that was put there by the hammer or the rolls. Steel annealed in this way will cut very soft; it will harden very hard, without cracking, and when tempered it will be strong, nicely refined, and will hold a keen, strong edge.

**Tempering.**—Tempering steel is the act of giving it, after it has been shaped, the hardness necessary for the work it has to do. This is done by first hardening the piece, generally a good deal harder than is necessary, and then toughening it by slow heating and gradual softening until it is just right for work.

A piece of steel properly tempered should always be finer in grain than the bar from which it is made. If it is necessary, in order to make the piece as hard as is required, to heat it so hot that after being hardened the grain will be as coarse as or coarser than the grain in the original bar, then the steel itself is of too low carbon for the desired work.

If a great degree of hardness is not desired, as in the case of taps and most tools of complicated form, and it is found that at a moderate heat the tools are too hard and are liable to crack, the smith should first use a lower heat in order to save the tools already made, and then notify the steel-maker that his steel is too high, so as to prevent a recurrence of the trouble.

For descriptions of various methods of tempering steel, see "Tempering of Metals," by Joshua Rose, in *App. Cyc. Mech.*, vol. ii, p. 863; also, "Wrinkles and Recipes," from the *Scientific American*. In both of these works Mr. Rose gives a "color scale," lithographed in colors, by which the following is a list of the tools in their order on the color scale, together with the approximate color and the temperature at which the color appears on brightened steel when heated in the air:

Scrapers for brass; <i>very pale yellow</i> , 430° F.	Hand-plane irons.
Steel-engraving tools.	Twist-drills.
Slight turning tools.	Flat drills for brass.
Hammer faces.	Wood-boring cutters.
Planer tools for steel.	Drifts.
Ivory-cutting tools.	Coopers' tools.
Planer tools for iron.	Edging cutters; <i>light purple</i> , 530° F.
Paper-cutters.	Augers.
Wood-engraving tools.	Dental and surgical instruments.
Bone-cutting tools.	Cold chisels for steel.
Milling-cutters; <i>straw yellow</i> , 460° F.	Axes; <i>dark purple</i> , 550° F.
Wire-drawing dies.	Gimlets.
Boring-cutters.	Cold chisels for cast iron.
Leather-cutting dies.	Saws for bone and ivory.
Screw-cutting dies.	Needles.
Inserted saw-teeth.	Firmer-chisels.
Taps.	Hack-saws.
Rock-drills.	Framing-chisels.
Chasers.	Cold chisels for wrought iron.
Punches and dies.	Molding and planing cutters to be filed.
Penknives.	Circular saws for metal.
Reamers.	Screw-drivers.
Half-round bits.	Springs.
Planing and molding cutters.	Saws for wood.
Stone-cutting tools; <i>brown yellow</i> , 500° F.	<i>Dark blue</i> , 570° F.
Gauges.	<i>Pale blue</i> . 610°.
	<i>Blue, tinged with green</i> , 630°.



**Uses of Crucible Steel of Different Carbons.** (Metcalf on Steel.) —  
 0.50 to 0.60 C, for hot work and for battering tools.  
 0.60 to 0.70 C, ditto, and for tools of dull edge.  
 0.70 to 0.80 C, battering tools, cold-sets, and some forms of reamers and taps.  
 0.80 to 0.90 C, cold-sets, hand-chisels, drills, taps, reamers and dies.  
 0.90 to 1.00 C, chisels, drills, dies, axes, knives, etc.  
 1.00 to 1.10 C, axes, hatchets, knives, large lathe-tools, and many kinds of dies and drills if care be used in tempering them.  
 1.10 to 1.50 C, lathe-tools, graving tools, scribes, scrapers, little drills, and many similar purposes.

The best all-around tool steel is found between 0.90 and 1.10 C; steel that can be adapted safely and successfully to more uses than any other.

**High-speed Tool Steel.** (A. L. Valentine, *Am. Mach.*, July 2, 1908.) — Eight brands of high-speed steel were analyzed with the following results:

Steel.	C.	W.	Cr.	Mn.	Si.	Mo.	P.	S.
a	0.70	14.91	2.95	0.01	.....	.....	0.013	0.008
b	0.25	17.27	2.69	Trace	0.179	.....	0.035	Trace
c	0.75	14.83	2.90	0.08	.....	5.19	0.02	0.01
d	0.49	17.60	5.11	.....	.....	.....	0.01	0.007
e	0.65	.....	.....	0.19	0.039	9.60	0.016	0.005
f	0.60	13.00	2.88	.....	.....	.....	0.019	0.01
g	0.55	17.81	2.48	0.11	0.090	.....	.....	.....
h	0.66	19.03	.....	.....	0.036	.....	0.015	.....

W, Wolfram, symbol for tungsten.

Where blanks appear in the table, the steel was not analyzed for these ingredients.

Many different brands of high-speed steel are being made. Some that have been marketed are almost worthless. From some of these steels a tool can be made from one end of a bar that is easily forged, machined and hardened, while the other end of the bar would resist almost any cutting tool and would invariably crack in hardening. Different bars of the same make also give very different results. These faults are sometimes caused by non-uniform annealing in the steels which are sent out as thoroughly annealed, and in many cases they are caused by the use of impure ingredients. A good high-speed steel will stand a temperature as high as 1200° F., or over double that of carbon steel, without losing its hardness, and experience has proven that the higher the temperature is raised over the white-heat point, the higher a temperature caused by friction the tool will withstand, before losing its intense hardness. The higher the percentage of carbon is, the more brittle and hard to work the steel will be, especially to forge. The steel which has given the best all-around results has contained about 0.40 C. The analysis of this same steel showed nearly 3% of chromium. The higher the percentage of tungsten in the steel, the better has been its cutting qualities. (See Best High-Speed Tool Steel, and description of the Taylor-White process of heat treatment, under "The Machine-Shop.")

### MANGANESE, NICKEL, AND OTHER "ALLOY" STEELS.

**Manganese Steel.** (H. M. Howe, *Trans. A. S. M. E.*, vol. xii.) — Manganese steel is an alloy of iron and manganese, incidentally, and probably unavoidably, containing a considerable proportion of carbon.

The effect of small proportions of manganese on the hardness, strength, and ductility of iron is probably slight. The point at which manganese begins to have a predominant effect is not known; it may be somewhere about 2.5%.

Manganese steel is very free from blow-holes; it welds with great difficulty; its toughness is increased by quenching from a yellow heat; its electric resistance is enormous, and very constant with changing temperature; it is low in thermal conductivity. Its remarkable combination of great hardness, which cannot be materially lessened by annealing, and great tensile strength, with astonishing toughness and ductility, at once creates and limits its usefulness.

The hardness of manganese steel seems to be of an anomalous kind. The alloy is hard, but under some conditions not rigid. It is very hard in its resistance to abrasion; it is not always hard in its resistance to impact.

Manganese steel forges readily at a yellow heat, though at a bright white heat it crumbles under the hammer. But it offers greater resistance to deformation, i.e., it is harder when hot, than carbon steel.

The most important single use for manganese steel is for the pins which hold the buckets of elevator dredges. Here abrasion chiefly is to be resisted. Another important use is for the links of common chain-elevators. As a material for stamp-shoes, for horse-shoes, for the knuckles of an automatic car-coupler, it has not met expectations.

Manganese steel has been regularly adopted for the blades of the Cyclone pulverizer. Some manganese-steel wheels are reported to have run over 300,000 miles each without turning, on a New England railroad.

**Manganese Steel and its Uses.** (E. F. Lake, *Am. Mach.*, May 16, 1907.)—When more than 2% and less than 6% of Mn is added, with C less than 0.5%, it makes steel very brittle, so that it can be powdered under a hand hammer. From 6% Mn up, this brittleness gradually disappears until 12% is reached, when the former strength returns and reaches its maximum at 15%. After this, a decrease in toughness, but not in transverse strength, takes place until 20% is reached, after which a rapid decrease in strength again takes place.

Steel with from 12 to 15% Mn and less than 0.5% of C is very hard and cannot be machined or drilled in the ordinary way; yet it is so tough that it can be twisted and bent into peculiar shapes without breaking. It is malleable enough to be used for rivets that are to be headed cold.

This hardness, toughness and malleability make manganese steel the most durable metal known, in its ability to resist wear, for such parts as the teeth on steam-shovel dippers, where they will outwear about three teeth made of the best tool steel; for plow points on road-building work; for frogs, switches and crossings in railroad construction; for fluted or toothed crushing rolls used on ore, coal and stone crushers; for gears, sprockets, link belts, etc., when used in places where they are subjected to the grinding wear of gritty particles of dust.

The higher the percentage of C in the steel, the less percentage of Mn will be required to produce brittleness. Si, however, neutralizes the injurious tendencies of Mn, and in Europe the Si-Mn alloy is used for automobile springs and gears. This steel is not high in Mn and can be rolled, while the peculiar properties given to steel by the addition of from 12 to 15% of manganese make such steel impossible to roll; therefore all parts made of this steel have to be cast, after which it can be forged and rendered tougher by quenching from a white heat.

One of its peculiarities is that it is softened by rapid cooling and can be restored to its former hardness by heating to a bright red.

It is more difficult to mold in the foundry than the ordinary cast steel, as it must be poured at a very high temperature, and in cooling it shrinks nearly twice as much. The shrinkage allowed for patterns to be cast of the ordinary cast steel is  $\frac{3}{16}$  in. per foot, and for manganese-steel castings  $\frac{5}{16}$  in. per foot.

This enormous shrinkage makes it impossible to cast in any intricate or delicate shapes, and as it is too hard to machine or drill successfully, all holes must be cored in the casting. If a close fit is desired in these they must be ground out with an emery wheel. These properties limit its use to a large extent.

The composition that seems to give the best results is: Mn, from 12 to 15%; C, not over 0.5%; P, not over 0.04%; S, not over 0.04%.

Manganese-steel castings should be annealed in order to remove any internal strains which may be caused by its high shrinkage and the fact that the outer surface cools so much quicker than the core, which leaves the center of the casting strained. This can be done by heating to 1500° F. and quenching in water, after which it can be hardened by heating to 900° and allowed to cool slowly. Manganese-steel castings, when tested in a  $\frac{7}{8}$ -inch round bar, should show:

T. S. per sq. in., not less than 140,000 lb.; E. L., not less than 90,000 lb.; Red. of area, not less than 50%; Elong. in 2 in., not less than 20%.

A new manganese steel containing between 5 and 9% of manganese, with carbon ranging from about 0.7 to about 1.3%, is described in U. S. Patent 1,113,539, Oct. 13, 1914, assigned to Taylor-Wharton Iron &

Steel Co. It is said to possess the characteristic hardness of regular manganese steel, while being cheaper.

**Chrome Steel.** (F. L. Garrison, *Jour. F. I.*, Sept., 1891.)—Chromium increases the hardness of iron, perhaps also the tensile strength and elastic limit, but it lessens its weldability.

Chromium does not appear to give steel the power of becoming harder when quenched or chilled. Howe states that chrome steels forge more readily than tungsten steels, and when not containing over 0.5 of chromium nearly as well as ordinary carbon steels of like percentage of carbon. On the whole, the status of chrome steel is not satisfactory. There are other steel alloys coming into use, which are so much better that it would seem to be only a question of time when it will drop entirely out of the race. Howe states that many experienced chemists have found no chromium, or but the merest traces, in chrome steel sold in the markets.

J. W. Langley (*Trans. A.S.C.E.*, 1892) says: Chromium, like manganese, is a true hardener of iron even in the absence of carbon. The addition of 1% or 2% of chromium to a carbon steel will make a metal which gets excessively hard. Hitherto its principal employment has been in the production of chilled shot and shell. Powerful molecular stresses result during cooling, and the shells frequently break spontaneously months after they are made.

**Tungsten Steel—Mushet Steel.** (J. B. Nau, *Iron Age*, Feb. 11, 1892.)—By incorporating simultaneously carbon and tungsten in iron, it is possible to obtain a much harder steel than with carbon alone, without danger of an extraordinary brittleness in the cold metal or an increased difficulty in the working of the heated metal.

When a special grade of hardness is required, it is frequently the custom to use a high tungsten steel, known in England as special steel. A specimen from Sheffield, used for chisels, contained 9.3% of tungsten, 0.7% of silver, and 0.6% of carbon. This steel, though used with advantage in its untempered state to turn chilled rolls, was not brittle; nevertheless it was hard enough to scratch glass.

A sample of Mushet's special steel contained 8.3% of tungsten and 1.73% of manganese.

According to analyses made by the Duc de Luynes of ten specimens of the celebrated Oriental damasked steel, eight contained tungsten, two of them in notable quantities (0.518% to 1%), while in all of the samples analyzed nickel was discovered ranging from traces to nearly 4%.

Stein & Schwartz, of Philadelphia, in a circular say: It is stated that tungsten steel is suitable for the manufacture of steel magnets, since it retains its magnetism longer than ordinary steel. Cast steel to which tungsten has been added needs a higher temperature for tempering than ordinary steel, and should be hardened only between yellow, red, and white. Chisels made of tungsten steel should be drawn between cherry-red and blue, and stand well on iron and steel. Tempering is best done in a mixture of 5 parts of yellow rosin, 3 parts of tar, and 2 parts of tallow, and then the article is once more heated and then tempered as usual in water of about 15° C.

**Aluminum Steel.** (Aluminum Co. of America, 1909.)—Aluminum is added to steel: To increase the soundness of tops of ingots, and consequently decrease the scrap losses; to quiet the ebullition in molten steel, permitting the successful pouring of "wild" steel; to prevent oxidation and increase the homogeneity of the steel; to increase tensile strength without decreasing ductility; to remove oxygen or oxides, the aluminum acting as a deoxidizer; to reduce the liability of the steel to oxidation; to produce smoother surfaced castings and ingots than is possible without the use of aluminum.

Aluminum is not a hardener of steel, and none of its alloys with steel have proved advantageous. Strictly speaking, there is no aluminum-steel in the sense that there is nickel-steel or chromium-steel. Aluminum is the principal deoxidizer of steel; 100 parts by weight of oxygen will combine with 114 parts of aluminum, 140 parts of silicon or 350 parts of manganese. The aluminum will entirely disappear if there is any oxygen present, and it only appears in completely deoxidized steel. If too much aluminum be added, the metal is liable to form deep pipes in the ingots. To add the correct quantity requires experience, but successful results have been obtained by adding from one-eighth to three-fourth pound of aluminum to the ton of steel. Steel ingots which are



to be hammered or rolled have been improved by the addition of two to four ounces of aluminum per ton of steel. For steel castings, to insure soundness and absence of blowholes, 16 to 32 ounces per ton may be advantageously added. The aluminum may be added by throwing the metal in small pieces into the ladle as the metal is poured into it, or by the use of ferro-aluminum placed in the ladle before pouring the steel. The metal is more commonly used in America, and the alloy in England.

**Nickel Steel.**—The remarkable tensile strength and ductility of nickel steel, as shown by the test-bars and the behavior of nickel-steel armor-plate under shot tests, are witness of the valuable qualities conferred upon steel by the addition of a few per cent of nickel.

Nickel steel has shown itself to be possessed of some exceedingly valuable properties; these are, resistance to cracking, high elastic limit, and homogeneity. Resistance to cracking, a property to which the name of non-fissibility has been given is shown more remarkably as the percentage of nickel increases. Bars of 27% nickel illustrate this property. A 1 1/4-in. square bar was nicked 1/4 in. deep and bent double on itself without further fracture than the splintering off, as it were, of the nicked portion. Sudden failure or rupture of this steel would be impossible; it seems to possess the toughness of rawhide with the strength of steel. With this percentage of nickel the steel is practically non-corrodible and non-magnetic. The resistance to cracking shown by the lower percentages of nickel is best illustrated in the many trials of nickel-steel armor.

In such places (shafts, axles, etc.) where failure is the result of the fatigue of the metal this higher elastic limit of nickel steel will tend to prolong indefinitely the life of the piece, and at the same time, through its superior toughness, offer greater resistance to the sudden strains of shock.

Howe states that the hardness of nickel steel depends on the proportion of nickel and carbon jointly, nickel up to a certain percentage increasing the hardness, beyond this lessening it. Thus while steel with 2% of nickel and 0.90% of carbon cannot be machined, with less than 5% nickel it can be worked cold readily, provided the proportion of carbon be low. As the proportion of nickel rises higher, cold-working becomes less easy. It forges easily whether it contain much or little nickel.

The presence of manganese in nickel steel is most important, as it appears that without the aid of manganese in proper proportions the conditions of treatment would not be successful.

**Properties of Nickel Steel.**—D. H. Browne, in *Proc. A. I. M. E.*, 1899, gives a paper of 79 pages, entitled “Nickel Steel: a synopsis of experiment and opinion,” including a bibliography containing 50 titles. Some extracts from this paper are here given.

Commercially pure nickel, containing 98.13 Ni, 1.15 Co, 0.43 Fe, 0.08 Si, 0.11 Mn, showed the following physical properties:

	L. P.*	E. L.	T. S.	M. E.*	El., % in 2 in.	
Cast bars.....	5,119	12,557	40,669	23,989,140	18.2	
Rolled. {	Raw.....	9,243	21,045	72,522	29,506,500	43.9
	Annealed.....	17,064	18,059	72,806	26,870,800	48.6
	Quenched.....	.....	16,921	71,860	.....	45.0

\* Limit of Proportionality.

\* Modulus of Elasticity.

**ANNEALED CAST BARS OF NICKEL STEEL WITH C 0.15 to 0.20.** (Hadfield.) The proportion of Ni used in soft steels for armor and for engine-forgings is from 3 to 3.5%. With 0.25 C this produces an E. L. and T. S. equal to open-hearth steel of 0.45 C without Ni, with a ductility equal to that of the lower-carbon steel.

**NICKEL STEEL, 3.25 NI, AND SIMPLE STEEL FORGINGS COMPARED.** (Bethlehem Steel Co.)

C.	Ni.	T. S.	E. L.	El., %.	Red. Area, %.	C.	Ni.	T. S.	E. L.	El., %.	Red. Area, %.
0.20	0	55000	28000	34	60	0.20	3.5	85000	48000	26	55
0.30	0	75000	37000	30	50	0.30	3.5	95000	60000	22	48
0.40	0	85000	43000	25	45	0.40	3.5	110000	72000	18	40
0.50	0	95000	48000	21	40	0.50	3.5	125000	85000	13	32

As compared with simple steels of the same tensile strength, a 3% nickel steel will have from 10 to 20% higher E. L. and from 20 to 30% greater elongation, while as compared with simple steels of the same carbon, the nickel steel, up to 5% Ni, will have about 40% greater tensile strength, with practically the same elongation and reduction of area.

Cholat and Harmet found with 0.30 C and 15% Ni a T. S. of 213,400 lbs. per sq. in.; when oil-tempered a T. S. of 277,290 and an E. L. of 166,300.

Riley states that steel of 25% Ni and 0.27 C gave a T. S. of 102,600 and elong. 29%, while steel of 25% Ni gave 94,300 T. S. and 40% elong. Steels high in Ni are entirely different in physical properties from low-nickel steels.

**EFFECT OF NI ON HARDNESS.**—Gun barrels with 4.5% Ni and 0.30 C are soft and very ductile; T. S. 80,000, elong. 25%, red. of area 45%. Rolls with 5% Ni and 1% C turned easier than simple steel of 1% C. If a steel contains less than 6% Ni the influence of the C present on the hardness produced by water quenching is strongly marked. Above 8% Ni the effect of the C seems to be masked by the Ni; steel with 18% Ni is as hard and elastic with 0.30 as with 0.75 C. If steel with 18% Ni and 0.60 C be heated and plunged in water it will be perceptibly softened, and if the Ni is raised to 25% this softening is very noticeable.

**COMPRESSION TESTS OF LOW-CARBON NICKEL STEELS. (Hadfield.)**

Carbon.....	0.13	0.14	0.19	0.18	0.17	0.16	0.18	0.23	0.19	0.16	0.14
Nickel.....	0.95	1.92	3.82	5.81	7.65	9.51	11.39	13.48	19.64	24.51	29.07
E. L., tons .....	20	27	28	40	40	70	100	80	80	50	24
Shortening* ...	49	47	41	37	33	3	1	1	3	16	41

\* Shortening by 100-ton load, %.

**SPECIFIC GRAVITY.**—The sp. gr. of low-carbon nickel steels containing up to 15% Ni is about the same as that of carbon steel, from 7.86 to 7.90; from 19 to 39% Ni it is from 7.91 to 8.08; one sample of wire of 29% Ni, however, being reported at 8.4. A 44% Ni steel, according to Guillaume, has a sp. gr. of 8.12.

**THE RESISTANCE OF CORROSION** of nickel steel increases with the percentage of Ni up to 18. "This alloy is practically non-corrodible." "Tico" resistance wire, 27.5% Ni, was very slightly rusted after a year's exposure in a wet cellar; iron wire under the same conditions was entirely changed to oxide. With the ordinary nickel steels, 3 to 3.5% Ni, corrosion is slightly less than in simple steels.

**ELECTRICAL RESISTANCE.**—All nickel steels have a high electrical resistance which does not seem to vary much with the percentage of Ni. The resistance wires, "Tico," "Superior," and "Climax," containing from 25 to 30% Ni, have about 48 times, while German silver has about 18 times the resistance of copper.

**MAGNETIC PROPERTIES.**—According to Guillaume all nickel steels below 25.7% Ni can be, at the same temperature, either magnetic or non-magnetic, according to their previous heat-treatment, and they show different properties at ascending and at descending temperatures. The low-nickel steels, 3 to 5% Ni, possess a magnetic permeability greater than that of wrought iron.

**Nickel Steel for Bridges.**—J. A. L. Waddell, *Trans. A. S. C. E.*, 1908, presents at length an argument in favor of the use of nickel steel in long-span bridges.

**Some Uses of Nickel Steel.** (F. L. Sperry, *A. I. M. E.*, xxv, 51.)—The propeller shaft of the U. S. cruiser Brooklyn was made of hollow-forged, oil-tempered nickel steel, 17 in. outside, 11 in. inside diam., length 38 ft. 11 in., weight per foot, 449 lbs. Test bars cut from the tube gave T. S., 90,350 to 94,245; E. L., 56,470 to 60,770; El. in 2 in., 25.5 to 28.0%; Red. of area, 59.8 to 61.3%. A solid shaft of the same elastic strength of simple steel, having an E. L. of  $\frac{3}{5}$  of that of the nickel steel, would be 18.9 in. diam., and would have weighed 920 lbs. per foot.

The rotating field of the 5000 H.P. electric generators of the Niagara Falls Power Co. is inclosed in a ring of forged nickel steel, outside diam. 139 $\frac{3}{8}$  in.; inside, 130 in.; width, 50 $\frac{3}{4}$  in.; weight, 28,840 lbs. It travels at the rate of nearly two miles per minute.

Nickel steel wire with 27.7% Ni and 0.40 C used for torpedo defense netting, 0.116 in. diam., gave a T. S. of 198,700; El. in 2 in., 6.25%; Red. of area, 16.5%.

Flange plate of soft nickel steel. Ni, 2.69; C, 0.08; Mn, 0.36; P, 0.045; S, 0.038, gave, average of 6 tests, T. S., 65,760; E. L., 47,080; El. in 8 in., 24.8%; Red. of area, 52.0%. For comparison: Soft carbon steel, C, 0.10; Mn, 0.27; P, 0.048; S, 0.039; T. S., 54,450; E. L., 35,240; El., 27.4%; Red. of area, 55.3%.

**Coefficients of Expansion of Nickel Steel.** (D. H. Browne, *A. I. M. E.*, 1899.)—Per degree C. (Prefix 0.0000 to the figures here given.)

% Ni.	26.	28.	28.7	30.4	31.4	34.6	35.6	37.3	39.4	44.4
Coeff.	1312	1131	1041	0458	0340	0137	0087	0356	0537	0856

For comparison: Brass, 1878; Hard steel, 1239; Soft steel, 1078; Platinum, 0884; Glass, 0861; Nickel, 1252. Ordinary commercial nickel steels, containing 3 to 4% Ni, have coefficients about the same as carbon steel. See also page 567.

*Invar* is a nickel-iron alloy, which is characterized by an extraordinarily low coefficient of expansion at ordinary temperatures. The analysis is about as follows:—carbon, 0.18; nickel, 35.5%; manganese, 0.42,—the other elements being low. Guillaume gives the mean coefficient of expansion for an alloy containing 35.6% nickel as  $(0.877 + 0.00117 t)^{10-6}$  between temperatures 0° C. and  $t^{\circ}$  C. where  $t$  does not exceed 200° C. This material is used in measuring instruments and for standards of length, chronometers, etc. Its expansion as compared with ordinary steel is about as 1:11.5; with brass, as 1:17.2; with glass, as 1:8.5. Alloys either richer or poorer in nickel show much greater expansion, and the alloy containing 47.5% nickel, known as “Platinite,” has the same coefficient of expansion as platinum and glass. See also page 567.

**Copper Steels.**—Pierre Breuil (*Jour. I. and S. I.*, 1907) gives an account of experiments on four series of copper steels containing respectively 0.15, 0.40, 0.65, and 1% of C with Cu in each ranging from 0 to 34%. An abstract of his principal conclusions is as follows:

Copper steel does not yield a metal capable of being rolled in practice, if Cu exceeds 4%.

When in the ingot state copper hardens steel in proportion as there is less C present.

Copper steels as rolled appear to be stronger in proportion as they contain more Cu. This difference is the more manifest in proportion as the C is lower:

Annealing leaves the steels with the same characteristics, but greatly reduces the differences observed in the case of the untreated steels. Quenching restores the differences encountered in the case of the steels as cast.

Copper steels equal nickel steels in tensile strength and would be less costly than the latter. They are no more brittle than nickel steels containing equivalent percentages of Ni. The steel containing 0.16% C and 4% Cu is remarkable in this respect.

The presence of copper makes the constituents of the steel finer, approximating them to classes containing higher percentages of C. While hardening the steel the presence of Cu does not render it brittle. It confers upon it a very fair degree of elasticity, while leaving the elongation good, thus conducing to the production of a most valuable metal.

Cutting tests were carried on with steels containing C about 1% and Cu 0%, 1%, and 3% respectively. The presence of Cu in no wise altered the cutting properties.

The presence of Cu was found to increase the electrical resistance, and a well-defined maximum was shown, coinciding with 2% Cu in 0.15 C, with 1.7% in 0.35% C, and with 0.5% Cu in 0.7 to 1% carbon steels.

**Nickel-Vanadium Steels.** (*Eng. Mag.*, April, 1906.)—M. Leon Guillet has investigated the influence of Ni and Va when used jointly.

In steels containing 0.20 C and from 2 to 12% of Ni, the tensile strength and the elastic limit are both materially increased by the addition of small percentages of Va. In no case should the Va exceed 1%, the best results being secured by the use of 0.7 to 1%. A steel containing 0.20 C, 2% of Ni, and 0.7% Va showed a tensile strength of 91,000 lbs., an elastic limit of 70,000 lbs., and an elongation of 23.5%. With 1% Va, the T. S. increased to 119,500 lbs., and the E. L. to 91,000 lbs., the elong. falling to 22%. A nickel steel of 0.20% C and 12% Ni gave, with 0.7 Va, a T. S. of over 200,000 lbs. and an E. L. of 172,000 lbs. per sq. in., the elong. being 6%, while with 1% Va the T. S. rose to 220,000 lbs.



and the E. L. to 176,000 lbs., the elongation remaining unchanged. When the Va is increased above 1% the tensile strength falls off, and the material begins to show evidence of brittleness. Similar effects are produced for steels of the higher carbon, but in a lesser degree.

When the nickel-vanadium steels are subjected to a tempering process the beneficial effects of the Va are still further emphasized. The tempering experiments of M. Guillet were conducted by heating the steel to a temperature of 850° C., and cooling in water at 20° C. The T. S. and the E. L. were increased, being nearly doubled for the low nickel content. Thus while the 0.20 C steel with 2% of Ni, untempered, and containing 0.7% of Va, gave a T. S. of 91,000 lbs., with an E. L. of 70,000 lbs., the same steel, tempered from 850° C., showed a T. S. of 168,000 lbs. and an E. L. of 150,000 lbs., the resistance to shock and the hardness being also increased.

**Static and Dynamic Properties of Steels.** (W. L. Turner, *Iron Age*, July 2, 1908.)—The term "crystallization" is a name given to designate phenomena due to the influences of shock and alternating stresses, whether pure or combined. The name has been advantageously altered to "intermolecular disintegration," but, whatever we choose to call it, there remains the evidence that some modification takes place in the structure of steel when the above-named forces are to be dealt with.

Resistance to fatigue is not a function of static strength.

An example of our knowledge of the "life" properties of ordinary steel is the case of the staying of a locomotive fire-box. Something is required which will possess considerable strength combined with the power to withstand a moderate degree of flexure in all directions. Experience has shown that the use of anything but the mildest steel for this work is prohibitive, and that wrought iron, or even copper, is still more satisfactory.

The writer has completed a preliminary investigation into the relative dynamic properties of iron and the various ordinary and alloy steels, the results being given in the accompanying table. The conditions of the "dynamic" tests were as follows:

A cylindrical test-piece, 6 in. long,  $\frac{3}{8}$  in. diam., finished with emery to remove all tool marks, is clamped at one end in a vise. A tool-steel head, in which there is cut a slot, is placed over the other end, the distance from the striking center of this head to the vise line being 4 in. A crank and connecting rod furnished the reciprocating motion for this head, thereby causing the test-piece to be deflected  $\frac{3}{8}$  in. each side of the neutral position. In addition to this alternating flexure, the test-piece is also subjected, at each reversal, to an impact, due to the slot on the reciprocating head. The sample undergoes 650 alternations per minute. A deflection of  $\frac{3}{8}$  in. on each side has the effect of imparting a permanent set to the test-piece.

On each class of steel a large number of dynamic tests were made, an average being taken of the results after elimination of those figures which were apparently abnormal.

It is apparent that the action of nickel is twofold: 1. It statically intensifies. 2. It dynamically "poisons." As an instance of this, take tests Nos. 13 and 15, the former being a 3.7% nickel steel and the latter a chrome-vanadium steel. In the annealed condition, the elastic limits of the two are almost identical, but at the same time the alternations of stress endured by the latter are  $2\frac{1}{4}$  times the number sustained by the nickel steel. Take again Nos. 17 and 18. The dynamic figures are more than three to one in favor of the chrome-vanadium product, whereas the difference in elastic limit is only about 3%.

It is manifest that the static action of vanadium is similar to that of nickel, but that its dynamic effects are the exact converse. The differences are markedly brought out in the quality figures, which invite attention as to comparison with those of ordinary carbon steel. Taking the latter as standard, the chrome-vanadium steels are as much above it as the nickel steels are below it.

Chromium, *per se*, does not appear to exert appreciable influence other than statically, but it is possible that the effect of this metal in a ternary steel might be very marked.

The dynamic attributes of plain carbon steel reach a maximum with about 0.25% C, falling away on both sides of this amount.

The quality figure in the case of the chrome-vanadium steel does not

Relative Strengths and Fatigue Resistance of Steels.

No.	Material.	Heat Treatment.	C.	Approximate Analysis.			Elastic Limit. (E.)	Tensile Str'gth	Elong. in 2 in. %.	Red. of Area, % (R.)	Alter-nations. (A.)	Quality. $E \times R \times A \div 10^6$
				Mn.	Cr.	Ni						
Elastic Limits, 30,000 to 60,000.												
1	Wrought iron.....	R.	0.05				32,020	49,450	42.5	53.8	583	1004
2	Mild Va steel.....	A.	0.11			0.19	32,120	54,400	44.0	60.1	1111	2143
3	Old plate.....	R.	0.24				58,160	70,840	25.5	53.4	612	1901
4	Mild steel.....	A.	0.18			0.40	39,460	60,650	35.0	62.6	871	2152
5	Mild steel.....	O. T.	0.18				45,390	70,030	33.0	64.0	777	2258
6	Forging steel.....	O. T.	0.26				43,010	61,850	34.0	63.4	1415	3858
7	Forging steel.....	A.	0.15			0.12	52,230	77,310	28.0	65.3	1175	4008
8	Va case hardening.....	A.	0.25	0.30			44,790	55,990	45.0	69.0	1958	6051
9	Cr-Ni steel.....	A.	0.36	0.95	1.70		56,520	81,370	32.0	68.5	978	3787
10	Steel casting.....	A.	0.18				34,690	58,800	28.0	44.9	269	419
11	Va steel casting.....	A.	0.19			0.076	44,340	70,250	25.5	44.9	850	1671
12	Cr-Va casting.....	A.	0.57	0.75		0.16	52,330	92,900	16.0	20.5	656	704
Elastic Limits, 60,000 to 100,000.												
13	Ni forging steel.....	A.	0.21		3.70		61,140	79,700	30.0	62.5	746	2851
14	Ni forging steel.....	O. T.	0.21		3.70		77,140	98,470	25.0	65.3	664	3345
15	Cr-Va forging.....	A.	0.26	1.00		0.16	61,920	92,900	25.0	57.3	1608	5706
16	Spring steel.....	A.	1.00				63,800	125,000	8.5	15.2	1260	1222
17	Cr-Va spring.....	A.	0.40	1.22		0.19	67,520	100,600	26.0	61.7	1406	5858
18	Cr-Ni-Va steel.....	A.	0.30	0.77	3.45	0.085	69,140	96,880	28.5	68.5	507	2402
19	Ni-Va steel.....	A.	0.24	0.72	3.40	0.15	79,260	99,700	25.0	64.0	798	4048
20	Cr-Ni-Va steel.....	A.	0.57	0.27	0.93	2.04	95,150	129,100	21.0	49.8	983	4659
21	Cr-Ni steel.....	T.	0.37	0.34	0.89	1.70	86,080	102,700	22.0	63.8	702	3855
Elastic Limits, 100,000 and Over.												
22	Spring steel.....	O. T.	1.00	0.30			101,000	186,300	9.5	16.1	561	912
23	Cr-Va spring.....	O. T.	0.40	0.77	1.22		195,300	208,500	10.0	36.3	480	3403
24	Cr-Va forging.....	O. T.	0.30	0.50	1.00	0.16	141,600	151,750	16.0	56.2	717	5705
25	Ni-Va steel.....	O. T.	0.24	0.72	3.40	0.15	129,900	134,600	18.0	64.8	626	5270
26	Cr-Ni-Va steel.....	O. T.	0.50	0.27	1.51	3.45	152,300	159,900	17.0	58.9	487	4369
27	Cr-Va spring.....	O. T.	0.40	0.77	1.22	0.19	183,400	187,600	14.0	50.6	634	5883
28	Cr-Ni steel.....	T.	0.36	0.34	0.95	1.70	134,500	150,300	15.5	53.5	579	4166

NOTES.—Static tests made on samples 1/2 in. diam. x 2 in. long. Dynamic tests made on the Landgraf-Turner alternating impact machine (old form). The quality figure is the product of: Elastic limit, representing useful strength; reduction of area, representing static ductility; dynamic figure, representing fatigue-resisting property—divided by 1,000,000 =  $E \times R \times A \div 10^6$ . Heat treatment, R., raw; A., annealed. O. T., oil tempered; T., tempered. Nos. 9, 17, 18, 20, 21, 26, 27, 28 were crucible steels, the others open-hearth.

appear to undergo much alteration in the process of oil tempering, but there are considerable variations in other cases. The dynamic test may eventually act as a reliable guide to the correct methods for the heat treatment of individual steels.

Strength for strength, the chrome-vanadium steels also have the advantage over all others as regards machining properties. Chrome-vanadium steel may be forged with the same ease as ordinary steel of similar contents, no special precaution being necessary as to temperatures.

**Comparative Effects of Cr and Va.** Sankey and J. Kent Smith, *Proc. Inst. M. E.*, 1904.

Cr.	Va.	T.S.*	E.L.*	El. in 2 in.	Red. A.	Cr.	Va.	T.S.*	E.L.*	El. in 2 in.	Red. A.
0.5	.....	34.0	22.9	33%	60.6%	1.0	0.15	48.6	36.2	24.	56.6
1.0	.....	38.2	25.0	30	57.3	1.0	0.15	†52.6	34.4	25.0	55.5
...	0.1	34.8	28.5	31	60.0	1.0	0.25	60.4	49.4	18.5	46.3
...	0.15	36.5	30.4	26	59.0	C-Mn		27.0	16.0	35.	60.0
...	0.25	39.3	34.1	24	59.0	C-Mn		†32.2	17.7	34.	52.6

\* Tons, of 2240 lbs., per sq. in. † Open-hearth steels; all the others are crucible. The last two steels in the table are ordinary carbon steels.

**Effect of Heat Treatment on Cr-Va Steel.** (H. R. Sankey and J. Kent Smith, *Proc. Inst. M. E.*, 1904, p. 1235.)—Various kinds of heat treatment were given to several Cr-Va steels, the results of which are recorded at length. The following is selected as a sample of the results obtained. Steel with C, 0.297; Si, 0.086; Mn, 0.29; Cr, 1.02; Va, 0.17. gave:

	Tens. Str.	Yield Point.	El. in 2 in.	Red. Area.	Im- pact.	Alter- na- tions.
As rolled.....	121,200	82,650	24.0%	44.9%	3.1	1906
Annealed 1/2 hr. at 800° C.....	87,360	47,260	34.5	53.1	15.6	2237
Soaked 12 hours at 800° C.....	86,020	68,100	33.7	51.5	11.2	.....
Water quenched at 800° C.....	167,100	135,070	7.5	16.6	1.2	174
Oil quenched at 800° C.....	122,080	82,880	22.0	35.2	2.4	296
Oil quenched at 800°, reheated to 350°.....	132,830	111,550	23.0	50.8	9.0	1314
Water quenched at 1200° C.....	209,440	191,520	1.2	1.5	*	*
Oil quenched at 1200° C.....	140,220	118,500	8.5	21.5	3.0	.....

\* Too hard to machine.

The impact tests were made on a machine described in *Eng'g*, Sept. 25, 1903, p. 431. The test-piece was 3/4 in. broad, notched so that 0.137 in. in depth remained to be broken through. The figures represent ft.-lbs. of energy absorbed. The piece was broken in one blow. The alternations-of-stress tests were made on Prof. Arnold's machine, described in *The Engineer*, Sept. 2, 1904, p. 227. The pieces were 3/8 in. square, one end was gripped in the machine and the free end, 4 in. long, was bent forwards and backwards about 710 times a minute, the motion of the free end being 3/4 in. on each side of the center line.

Tests by torsion of the same steel were made. The test-piece was 6 in. long, 3/4 in. diam. The results were:

	Shearing Stress			No. of Twists.
	Elastic.	Ulti- mate.	Twist Angle.	
As rolled.....	45,700	99,900	1410°	3.92
Annealed 1/2 hr. at 800° C.....	38,528	90,272	1628°	4.52



**Heat-treatment of Alloy Steels.** (E. F. Lake, *Am. Mach.*, Aug. 1, 1907.) — In working the high-grade alloy steels it is very important that they be properly heat treated, as poor workmanship in this regard will produce working parts that are no better than ordinary steel, although the stock used be the highest grade procurable. By improperly heat-treating them it is possible to make these high-grade steels more brittle than ordinary carbon steels.

The theory of heat treatment rests upon the influence of the rate of cooling on certain molecular changes in structure occurring at different temperatures. These changes are of two classes, critical and progressive; the former occur periodically between certain narrow temperature limits, while the latter proceed gradually with the rise in temperature, each change producing alterations in the physical characteristics. By controlling the rate of cooling, these changes can be given a permanent set, and the characteristics can thus be made different from those in the metal in its normal state.

The results obtained are influenced by certain factors: 1. The original chemical and physical properties of the metal; 2. The composition of the gases and other substances which come in contact with the metal in heating and cooling. 3. The time in which the temperature is raised between certain degrees. 4. The highest temperature attained. 5. The length of time the metal is maintained at the highest temperature. 6. The time consumed in allowing the temperature to fall to atmospheric.

The highest temperature that it is safe to submit a steel to for heat-treating is governed by the chemical composition of the steel. Thus pure carbon steel should be raised to about 1300° F., while some of the high-grade alloy steels may safely be raised to 1750°. The alloy steels must be handled very carefully in the processes of annealing, hardening, and tempering; for this reason special apparatus has been installed to aid in performing these operations with definite results.

The baths for quenching are composed of a large variety of materials. Some of the more commonly used are as follows, being arranged according to their intensity on 0.85% carbon steel: Mercury; water with sulphuric acid added; nitrate of potassium; sal ammoniac; common salt; carbonate of lime; carbonate of magnesia; pure water; water containing soap, sugar, dextrine or alcohol; sweet milk; various oils; beef suet; tallow; wax.

With many of these alloy steels a dual quenching gives the best results, that is, the metal is quenched to a certain temperature in one bath and then immersed in the second one until completely cooled, or it may be cooled in the air after being quenched in the first bath. For this a lead bath, heated to the proper temperature, is sometimes used for the first quenching.

With the exception of the oils and some of the greases, the quenching effect increases as the temperature of the bath lowers. Sperm and linseed oils, however, at all temperatures between 32° and 250°, act about the same as distilled water at 160°.

The more common materials used for annealing are powdered charcoal, charred bone, charred leather, fire clay, magnesia or refractory earth. The piece to be annealed is usually packed in a cast-iron box in some of these materials or combinations of them, the whole heated to the proper temperature and then set aside, with the cover left on, to cool gradually to the atmospheric temperature. For certain grades of steel these materials give good results; but for all kinds of steels and for all grades of annealing, the slow-cooling furnace no doubt gives the best satisfaction, as the temperature can be easily raised to the right point, kept there as long as necessary, and then regulated to cool down as slowly as is desired. The gas furnace is the easiest to handle and regulate.

A high-grade alloy steel should be annealed after every process in manufacturing which tends to throw it out of its equilibrium, such as forging, rolling and rough machining, so as to return it to its natural state of repose. It should also be annealed before quenching, case-hardening or carbonizing.

The wide range of strength given to some of the alloy steels by heat

treatment is shown by the table below. The composition of the alloy was: Ni, 2.43; Cr, 0.42; Si, 0.26; C, 0.23; Mn, 0.43; P, 0.025; S, 0.022.

	Quenched at 1550° F.	Tempered at 575° F.	Tempered at 800° F.	Tempered at 925° F.	Tempered at 1025° F.	Tempered at 1125° F.	Tempered at 1550° F.
Tensile Strength . . . . .	227,000	219,000	195,500	172,000	156,500	141,000	109,500
E. L. . . . .	208,000	203,500	150,000	148,500	125,000	102,000	70,500
Elong., % in 2 in.	4	6	8	11	13	15	22

### VARIOUS SPECIFICATIONS FOR STEEL.

**Structural Steel.** — There has been a change during the ten years from 1880 to 1890, in the opinions of engineers, as to the requirements in specifications for structural steel, in the direction of a preference for metal of low tensile strength and great ductility. The following specifications for tension members at different dates are given by A. E. Hunt and G. H. Clapp, *Trans. A. I. M. E.*, xix, 926:

	1879.	1881.	1882.	1885.	1887.	1888.
Elastic limit. . . . .	50,000	40 @ 45,000	40,000	40,000	40,000	38,000
Tensile strength	80,000	70 @ 80,000	70,000	70,000	67 @ 75,000	63 @ 70,000
Elongation in 8 in.	12%	18%	18%	18%	20%	22%
Reduction of area	20%	30%	45%	42%	42%	45%

F. H. Lewis (*Iron Age*, Nov. 3, 1892) says: Regarding steel to be used under the same conditions as wrought iron, that is, to be punched without reaming, there seems to be a decided opinion (and a growing one) among engineers, that it is not safe to use steel in this way, when the ultimate tensile strength is above 65,000 lbs. The reason for this is not so much because there is any marked change in the material of this grade, but because all steel, especially Bessemer steel, has a tendency to segregations of carbon and phosphorus, producing places in the metal which are harder than they normally should be. As long as the percentages of carbon and phosphorus are kept low, the effect of these segregations is inconsiderable; but when these percentages are increased, the existence of these hard spots in the metal becomes more marked, and it is therefore less adapted to the treatment to which wrought iron is subjected.

There is a wide consensus of opinion that at an ultimate of 64,000 to 65,000 lbs. the percentages of carbon and phosphorus reach a point where the steel has a tendency to crack when subjected to rough treatment.

A grade of steel, therefore, running in ultimate strength from 54,000 to 62,000 lbs., or in some cases to 64,000 lbs., is now generally considered a proper material for this class of work.

A. E. Hunt, *Trans. A. I. M. E.*, 1892, says: Why should the tests for steel be so much more rigid than for iron destined for the same purpose? Some of the reasons are as follows: Experience shows that the acceptable qualities of one melt of steel offer no absolute guarantee that the next melt to it, even though made of the same stock, will be equally satisfactory.

It is now almost universally recognized that soft steel, if properly made and of good quality, is for many purposes a safe and satisfactory substitute for wrought iron, being capable of standing the same shop-treatment as wrought iron. But the conviction is equally general, that poor steel, or an unsuitable grade of steel, is a very dangerous substitute for wrought iron even under the same unit strains.

For this reason it is advisable to make more rigid requirements in selecting material which may range between the brittleness of glass and a ductility greater than that of wrought iron.

**Specifications for Structural Steel for Bridges.** (*Proc. A. S. T. M.*, 1905.)—Steel shall be made by the open-hearth process. The chemical and physical properties shall conform to the following limits:

Elements Considered.	Structural Steel.	Rivet Steel.	Steel Castings
Phosphorus. { Basic... Max. . . . . { Acid....	0.04% 0.08%	0.04% 0.04%	0.05% 0.08%
Sulphur, Max. . . . .	0.05%	0.04%	0.05%
Tensile strength, lbs. per sq. in. . . . .	{ Desired 60,000	Desired 50,000	Not less than 65,000
Elong.: Min. % in 8 in.	{ 1,500,000* tens. str.	1,500,000 tens. str.	
Elong.: Min. % in 2 in.	22	.....	18
Fracture. . . . .	Silky	Silky	Silky or fine granular
Cold bend without fracture. . . . .	180° flat†	180° flat‡	90°. $d=3t$

\* The following modifications will be allowed in the requirements for elongation for structural steel: For each 1/16 inch in thickness below 5/16 inch, a deduction of 2 1/2 will be allowed from the specified percentage. For each 1/8 inch in thickness above 3/4 inch, a deduction of 1 will be allowed from the specified percentage.

† Plates, shapes and bars less than 1 in. thick shall bend as called for. Full-sized material for eye-bars and other steel 1 in. thick and over, tested as rolled, shall bend cold 180° around a pin of a diameter twice the thickness of the bar, without fracture on the outside of bend. When required by the inspector, angles 3/4 in. and less in thickness shall open flat, and angles 1/2 in. and less in thickness shall bend shut, cold, under blows of a hammer, without sign of fracture.

‡ Rivet steel, when nicked and bent around a bar of the same diameter as the rivet rod, shall give a gradual break and a fine, silky, uniform fracture.

If the ultimate strength varies more than 4000 lbs. from that desired, a retest may be made, at the discretion of the inspector, on the same gauge, which, to be acceptable, shall be within 5000 lbs. of the desired strength.

Chemical determinations of C, P, S, and Mn shall be made from a test ingot taken at the time of the pouring of each melt of steel. Check analyses shall be made from finished material, if called for by the purchaser, in which case an excess of 25% above the required limits will be allowed.

Specimens for tensile and bending tests for plates, shapes and bars shall be made by cutting coupons from the finished product, which shall have both faces rolled and both edges milled with edges parallel for at least 9 in.; or they may be turned 3/4 in. diam. for a length of at least 9 in., with enlarged ends. Rivet rods shall be tested as rolled. Specimens shall be cut from the finished rolled or forged bar in such manner that the center of the specimen shall be 1 in. from the surface of the bar. The specimen for tensile test shall be turned with a uniform section 2 in. long, with enlarged ends. The specimen for bending test shall be 1 x 1/2 in. in section.

**Specifications for Steel for the Manhattan Bridge.** (*Eng. News*, Aug. 3, 1905.)—

**MATERIAL FOR CABLES, SUSPENDERS AND HAND ROPES.** Open-heart steel. (The wire for serving the cables shall be made of Norway iron of approved quality.) The ladle tests of the steel shall contain not more than : C, 0.85; Mn, 0.55; Si, 0.20; P, 0.04; S, 0.04; Cu, 0.02%. The wire shall have an ultimate strength of not less than 215,000 lbs. per sq. in. before galvanizing, and an elongation of not less than 2% in 12 in. The bright wire shall be capable of bending cold around a rod 1 1/2 times its own diam. without sign of fracture. The cable wire before galvanizing shall be 0.192 in. ± 0.003 in. in diam.; after galvanizing, the wire shall have an ultimate strength of not less than 200,000 lbs. per sq. in. of gross section.



**CARBON STEEL.** The ladle tests as usually taken shall contain not more than: P, 0.04; S, 0.04; Mn, 0.60; Si, 0.10%. The ladle tests of the carbon rivet steel shall contain not more than: P, 0.035; S, 0.03. Rivet steel shall be used for all bolts and threaded rods.

**NICKEL STEEL.** The ladle test shall contain not less than 3.25 Ni, and not more than: P, 0.04; S, 0.04; Mn, 0.60; Si, 0.10; nickel rivet steel not more than: P, 0.035; S, 0.03%.

Nickel steel for plates and shapes in the finished material must show: T. S., 85,000 to 95,000 lbs. per sq. in.; E. L., 55,000 lbs. min.; elong. in 8 ins., min., = 1,600,000 ÷ T. S.; min. red. of area, 40%.

Specimens cut from the finished material shall show the following physical properties:

Material.	T. S., lbs. per sq. in.	Min. E. L., lbs. per sq. in.	Min. Elong., % in 8 in.	Min. Red. of Area, %.
Shapes and universal mill plates.....	60,000 to 68,000	33,000	1,500,000 ultimate	44
Eye-bars, pins and rollers.	64,000 to 72,000	35,000		40
Sheared plates.....	60,000 to 68,000	33,000		44
Rivet rods.....	50,000 to 58,000	30,000		50
High-carbon steel for trusses.....	85,000 to 95,000	45,000		35

Nickel rivet steel: T. S., 70,000 to 80,000; E. L., min., 45,000; elong., min., 1,600,000 ÷ T. S., % in 8 ins.

**STEEL CASTINGS.** The ladle test of steel for castings shall contain not more than: P, 0.05; S, 0.05; Mn, 0.80; Si, 0.35%. Test-pieces taken from coupons on the annealed castings shall show T. S., 65,000; E. L., 35,000; elong. 20% in 8 ins. They shall bend without cracking around a rod three times the thickness of the test-piece.

### Specifications for Steel. (Proc. A. S. T. M., 1905.)

Steel Forgings.	Kind of Steel.	Tensile Strength.	Elast. Limit.	El. in 2 in., %.	Red Area, %.
Solid or hollow forgings, no diam. or thickness of section to exceed 10 in.	S.	58,000	29,000*	28	35 (a)
	C.	75,000	37,500*	18	30 (c)
	C. A.	80,000	40,000	22	35 (b)
	N. A.	80,000	50,000	25	45 (a)
Solid or hollow forgings, diam. not to exceed 20 in. or thickness of section 15 in.	C. A.	75,000	37,500	23	35 (b)
	N. A.	80,000	45,000	25	45 (a)
Solid forgings, over 20 in.....	C. A.	70,000	35,000	24	30 (c)
Solid forgings.....	N. A.	80,000	45,000	24	40 (a)
Solid or hollow forgings, diam. or thickness not over 3 in.	C. O.	90,000	55,000	20	45 (b)
	N. O.	95,000	65,000	21	50 (b)
Solid rectangular sections, thickness not over 6 in., or hollow with walls not over 6 in. thick.	C. O.	85,000	50,000	22	45 (b)
	N. O.	90,000	60,000	22	50 (b)
Solid rect. sections, thickness not over 10 in., or hollow with walls not over 10 in. thick.	C. O.	80,000	45,000	23	40 (b)
	N. O.	85,000	55,000	24	45 (b)
Locomotive forgings .....		80,000	40,000	20	25 (d)

\* The yield point, instead of the elastic limit, is specified for soft steel and carbon steel not annealed. It is determined by the drop of the beam or halt in the gauge of the testing machine. The elastic limit, specified for all other steels, is determined by an extensometer, and is defined as that point where the proportionality changes. The standard test specimen is 1/2 in. turned diam. with a gauged length of 2 inches.

Kind of steel: S., soft or low carbon. C., carbon steel, not annealed. C. A., carbon steel, annealed. C. O., carbon steel, oil tempered. N. A., nickel steel, annealed. N. O., nickel steel, oil tempered. Bending tests: A specimen 1 × 1/2 in. shall bend cold 180° without fracture on outside of bent portion, as follows: (a) around a diam. of 1/2 in.; (b) around a diam. of 1 in.; (c) around a diam. of 1/2 in.; (d) no bending test required.

Chemical composition: P and S not to exceed 0.10 in low-carbon steel, 0.06 in carbon steel not annealed, 0.04 in carbon or nickel steel oil tempered or annealed, 0.05 in locomotive forgings. Mn not to exceed 0.60 in locomotive forgings. Ni 3 to 4% in nickel steel.

**Specifications for Steel Ship Material.** (Amer. Bureau of Shipping, 1900. *Proc. A. S. T. M.*, 1906, p. 175.) —

For Hull Construction.	Tens. Strength.	E. L.	El. in 8 in., %.
Plates, angles and shapes.....	58,000 to 60,000	1/2 T. S.	22* 18 †
Castings.....	60,000 to 75,000	.....	15
Forgings.....	55,000 to 65,000	.....	20

\* In plates 18 lbs. per sq. ft. and over. † In plates under 18 lbs.

**FOR MARINE BOILERS:** Open-hearth steel; Shell: P and S, each not over 0.04%. Fire-box, not over 0.035%. Tensile Strength: Rivet steel, 45,000 to 55,000; Fire-box, 52,000 to 62,000; Shell, 55,000 to 73,000; Braces and stays, 55,000 to 65,000; Tubes and all other steel, 52,000 to 62,000 lbs. per sq. in.

Elongation in 8 in.: Rivet steel, 28%; Plates 3/8 in. and under, 20%; 3/8 to 3/4 in., 22%; 3/4 in. and over, 25%.

**COLD BENDING AND QUENCHING TESTS.** Rivet steel and all steel of 52,000 to 62,000 lbs. T. S., 1/2 in. thick and under, must bend 180° flat on itself without fracture on outside of bent portion; over 1/2 in. thick, 180° around a mandrel 1 1/2 times the thickness of the test-piece. For hull construction a specimen must stand bending on a radius of half its thickness, without fracture on the convex side, either cold or after being heated to cherry-red and quenched in water at 80° F.

**High-strength Steel for Shipbuilding.** (*Eng'g*, Aug. 2, 1907, p. 137.)—The average tensile strength of the material selected for the *Lusitania* was 82,432 lbs. per sq. in. for normal high-tensile steel, and 81,984 lbs. for the same annealed, as compared with 66,304 lbs. for ordinary mild steel. The metal was subjected to tup tests as well as to other severe punishments, including the explosion of heavy charges of dynamite against the plates, and in every instance the results were satisfactory. It was not deemed prudent to adopt the high-tensile steel for the rivets, a point upon which there seems some difference of opinion.

**Penna. R. R. Specifications for Steel.**

	Note.	Date.	C.	Mn.	Si.	P.	S.	Cu.
Plates for steel cars.....	(1)	1899	0.12	0.35	0.05	0.04	0.03	.....
Bar spring steel.....	.....	1901	1.00	0.25	0.15	0.03	0.03	0.03
Steel for axles.....	(2)	1899	0.40	0.50	0.05	0.05	0.04	.....
Steel for crank pins.....	(3)	1904	0.45	0.60	0.05	0.03	0.04	.....
Billets or blooms for forging	(4)	1902	0.45	0.50	0.05	0.03	0.02	0.03
Boiler-shell sheets.....	(5)	1906	0.18	0.40	0.05	0.04	0.03	0.03
Fire-box sheets.....	(6)	1906	0.18	0.40	0.02	0.03	0.02	0.03

The minus sign after a figure means "or less." The figures without the minus sign represent the composition desired.

Steel castings. Desired T. S., 70,000 lbs. per sq. in.; elong. in 2 in., 15%. Will be rejected if T. S. is below 60,000, or elong. below 12%, or if the castings show blow-holes or shrinkage cracks on machining.

NOTES. (1) Tensile strength, 52,000 lbs. per sq. in.; elong. in 8 ins. =  $1,500,000 \div T. S.$  (2) Axles are also subjected to a drop test, similar to that of the A. S. T. M. specifications. Axles will be rejected if they contain C below 0.35 or above 0.50, Mn above 0.60, P above 0.07%. (3) T. S. desired, 85,000 lbs. per sq. in.; elong. in 8 ins. 18%. Pins will be rejected if the T. S. is below 80,000 or above 95,000, if the elongation is less than 12%, or if the P is above 0.05%. (4) The steel will be rejected if the C is below 0.35 or above 0.50, Si above 0.25, S above 0.05, P above 0.05, or Mn above 0.60%. (5) T. S. desired, 60,000; elong. in 8 ins. 26%. Sheets will be rejected if the T. S. is less than 55,000 or over 65,000, or if the elongation is less than the quotient of 1,400,000 divided by the T. S., or if P is over 0.05%. (6) T. S. desired, 60,000, with elong. of 28% in 8 in. Sheets will be rejected if the T. S. is less than 55,000 or above 65,000 (but if the elong. is 30% or over plates will not be rejected for high T. S.), if the elongation is less than  $1,450,000 \div T. S.$ , if a single seam or cavity more than  $\frac{1}{4}$  in. long is shown in either one of the three fractures obtained in the test for homogeneity, described below, or if on analysis C is found below 0.15 or over 0.25, P over 0.035, Mn over 0.45, Si over 0.03, S over 0.045, or Cu over 0.05%.

*Homogeneity Test for Fire-box Steel.* — This test is made on one of the broken tensile-test specimens, as follows:

A portion of the test-piece is nicked with a chisel, or grooved on a machine, transversely about a sixteenth of an inch deep, in three places about 2 in. apart. The first groove should be made on one side, 2 in. from the square end of the piece; the second, 2 in. from it on the opposite side; and the third, 2 in. from the last, and on the opposite side from it. The test-piece is then put in a vise, with the first groove about  $\frac{1}{4}$  in. above the jaws, care being taken to hold it firmly. The projecting end of the test-piece is then broken off by means of a hammer, a number of light blows being used, and the bending being away from the groove. The piece is broken at the other two grooves in the same way. The object of this treatment is to open and render visible to the eye any seams due to failure to weld up, or to foreign interposed matter, or cavities due to gas bubbles in the ingot. After rupture, one side of each fracture is examined, a pocket lens being used if necessary, and the length of the seams and cavities is determined. The sample shall not show any single seam or cavity more than  $\frac{1}{4}$  in. long in either of the three fractures.

Dr. Chas. B. Dudley, chemist of the P. R. R. (*Trans. A. I. M. E.*, 1892), referring to tests of crank-pins, says: In testing a recent shipment, the piece from one side of the pin showed 88,000 lbs. strength and 22% elongation, and the piece from the opposite side showed 106,000 lbs. strength and 14% elongation. Each piece was above the specified strength and ductility, but the lack of uniformity between the two sides of the pin was so marked that it was finally determined not to put the lot of 50 pins in use. To guard against trouble of this sort in future, the specifications are to be amended to require that the difference in ultimate strength of the two specimens shall not be more than 3000 lbs.

**Specifications for Steel Rails.** (Adopted by the manufacturers of the U. S. and Canada. In effect Jan. 1, 1909.)— Bessemer rails:

Wt. per yard, lbs.	50 to 60	61 to 70	71 to 80	81 to 90	91 to 100
Carbon, %	0.35-0.45	0.35-0.45	0.40-0.50	0.43-0.53	0.45-0.55
Manganese, %	0.70-1.00	0.70-1.00	0.75-1.05	0.80-1.10	0.84-1.14

Phosphorus not over 0.10%; silicon not over 0.20%. Drop Test: A piece of rail 4 to 6 ft. long, selected from each blow, is placed head upwards on supports 3 ft. apart. The anvil weighs at least 20,000 lbs., and the tup, or falling weight, 2000 lbs. The rail should not break when the drop is as follows:

Weight per yard, lbs.	71 to 80	81 to 90	91 to 100
Height of drop, feet	16	17	18

If any rail breaks when subjected to the drop test, two additional tests will be made of other rails from the same blow of steel, and if either of



these latter tests fail, all the rails of the blow which they represent will be rejected; but if both of these additional test-pieces meet the requirements, all the rails of the blow which they represent will be accepted.

**Shrinkage:** The number of passes and the speed of the roll train shall be so regulated that for sections 75 lbs. per yard and heavier the temperature on leaving the rolls will not exceed that which requires a shrinkage allowance at the hot saws of  $6\frac{11}{16}$  inches for a 33-ft. 75-lb. rail, with an increase of  $\frac{1}{16}$  in. for each increase of 5 lbs. in the weight of the section.

**Open-hearth rails; chemical specifications:**

Weight per yard, lbs. . . . . 50 to 60 61 to 70 71 to 80 81 to 90 90 to 100  
Carbon, % . . . . . 0.46-0.59 0.46-0.59 0.52-0.65 0.59-0.72 0.62-0.75

Manganese, 0.60 to 0.90; Phosphorus, not over 0.04; Silicon, not over 0.20. Drop Tests: 50 to 60-lb., 15 ft.; 61 to 70-lb., 16 ft.; heavier sections same as Bessemer.

**Specifications for Steel Axles.** (*Proc. A. S. T. M.*, 1905 p. 56.) —

	P. & S. †	Tens. Str.	Yield Pt.	El. in 2 in.	Red. Area.
Car and tender truck . . . . .	0.06				
Driving and engine truck, C. S.* . . . . .	0.06	80,000	40,000	20%	25%
Driving and engine truck, N. S.† . . . . .	0.04	80,000	50,000	25%	45%

\* Carbon steel.

† Nickel steel, 3 to 4 % Ni.

‡ Each not to exceed. Mn in carbon steel not over 0.60 %.

**Drop Tests.** — One drop test to be made from each melt. The axle rests on supports 3 ft. apart, the tup weighs 1640 lbs., the anvil supported on springs, 17,500 lbs.; the radius of the striking face of the tup is 5 in. The axle is turned over after the first, third and fifth blows. It must stand the number of blows named below without rupture and without exceeding, as the result of the first blow, the deflection given.

Diam. axle at center, in. . . . .	41/4	43/8	47/16	45/8	43/4	53/8	57/8
Number of blows . . . . .	5	5	5	5	5	5	7
Height of drop, ft. . . . .	24	26	28 1/2	31	34	43	43
Deflection, in. . . . .	8 1/4	8 1/4	8 1/4	8	8	7	5 1/2

**Specifications for Tires.** (*A. S. T. M.*, 1901.) — Physical requirements of test-piece 1/2 in. diam. Tires for passenger engines: T. S., 100,000; El. in 2 in., 12%. Tires for freight engines and car wheels: T. S., 110,000; El., 10%. Tires for switching engines: T. S., 120,000; El., 8%.

**Drop Test.** — If a drop test is called for, a selected tire shall be placed vertically under the drop on a foundation at least 10 tons in weight and subjected to successive blows from a tup weighing 2240 lbs. falling from increasing heights until the required deflection is obtained, without breaking or cracking. The minimum deflection must equal  $D^2 + (40T^2 + 2D)$ ,  $D$  being internal diameter and  $T$  thickness of tire at center of tread.

**Splice-bars.** (*A. S. T. M.*, 1901.) — Tensile strength of a specimen cut from the head of the bar, 54,000 to 64,000 lbs.; yield point, 32,000 lbs. Elongation in 8 in., not less than 25 per cent. A test specimen cut from the head of the bar shall bend 180° flat on itself without fracture on the outside of the bent portion. If preferred, the bending test may be made on an unpunched splice-bar, which shall be first flattened and then bent. One tensile test and one bending test to be made from each blow or melt of steel.

**Specifications for Steel Used in Automobile Construction.**  
(E. F. Lake, *Am. Mach.*, March 14, 1907.) —

	C.	Mn.	Cr.	Ni.	P.	S.	T. S.	E. L.	El. in 2 in.	R. of A.
(1)	0.40-0.55	0.40-	0.80+	1.50+	0.04-	0.04-	{ 90000+ 180000+	{ 65000+ 140000+	{ 18+ 8+	{ 35+a 20+b
(2)	0.20-0.35	0.40-	0.80+	1.50+	0.04-	0.04-	{ 85000+ 130000+	{ 65000+ 100000+	{ 20+ 12+	{ 50+a 30+b
(3)	0.25	0.40	1.50	3.50	0.015	0.025	120000	105000	20	58c
(4)	0.25-0.35	0.60	.....	1.50+	0.03	0.04	{ 85000+ 100000+	{ 60000+ 70000+	{ 25+ 20+	{ 50+a 50+b
(5)	0.45-0.55	1.1-1.3	.....	.....	0.065-	0.06-	85000+	55000+	15+	45+c
(6)	0.28-0.36	0.3-0.6	.....	.....	0.05-	0.06-	75000+	40000+	25+	40+c
(7)	0.85-1.00	0.25-0.5	.....	.....	0.03-	0.03-	.....	.....	.....	.....
(8)	0.50	1.50-	.....	30.0	0.04-	0.06-	.....	.....	.....	.....

The plus sign means "or over"; the minus sign "or less."

a, fully annealed; b, heat-treated, that is oil-quenched and partly annealed; c, as rolled.

(1) 45% carbon chrome-nickel steel, for gears of high-grade cars. When annealed this steel can be machined with a high-speed tool at the rate of 35 ft. per min., with a 1/16-in. feed and a 3/16-in. cut. It is annealed at 1400° F. 4 or 5 hours, and cooled slowly. In heat-treating it is heated to 1500°, quenched in oil or water and drawn at 500° F.

(2) 25% carbon chrome-nickel steel, for shafts, axles, pivots, etc. This steel may be machined at the same rate as (1), and it forges more easily.

(3) A foreign steel used for forgings that have to withstand severe alternating shocks, such as differential shafts, transmission parts, universal joints, axles, etc.

(4) Nickel steel, used instead of (1) in medium and low-priced cars.

(5) "Gun-barrel" steel, used extensively for rifle barrels, also in low-priced automobiles, for shafts, axles, etc. It is used as it comes from the maker, without heat-treating.

(6) Machine steel. Used for parts that do not require any special strength.

(7) Spring steel used in automobiles.

(8) Nickel steel for valves. Used for its heat-resisting qualities in valves of internal-combustion engines.

*Carbonizing or Case-hardening.* — Some makers carbonize the surface of gears made from steel (1) above. They are packed in cast-iron boxes with a mixture of bone and powdered charcoal and heated four hours at nearly the melting-point of the boxes, then cooled slowly in the boxes. They are then taken out, heated to 1400° F. for four hours to break up the coarse grain produced by the carbonizing temperature. After this the work is heat-treated as above described.

The machine steel (6) case-hardens well by the use of this process.

**Specifications for Steel Castings.** (*Proc. A. S. T. M.*, 1905, p. 53.) — Open-hearth, Bessemer, or crucible. Castings to be annealed unless otherwise specified. Ordinary castings, in which no physical requirements are specified, shall contain not over 0.04 C and not over 0.08 P. Castings subject to physical test shall contain not over 0.05 P and not over 0.05 S. The minimum requirements are:

	T. S.	Y. P.	El. in 2 in.	Red. Area.
Hard castings.....	85,000	38,250	15 %	20 %
Medium castings.....	70,000	31,500	18 %	25 %
Soft castings.....	60,000	27,000	22 %	30 %

For small or unimportant castings a test to destruction may be substituted. Three samples are selected from each melt or blow, annealed in the same furnace charge, and shall show the material to be ductile and free from injurious defects, and suitable for the purpose intended. Large castings are to be suspended and hammered all over. No cracks, flaws, defects nor weakness shall appear after such treatment. A specimen  $1 \times \frac{1}{2}$  in. shall bend cold around a diam. of 1 in. without fracture on outside of bent portion, through an angle of  $120^\circ$  for soft and  $90^\circ$  for medium castings.

Specifications for steel castings issued by the U. S. Navy Department, 1889 (abridged): Steel for castings must be made by either the open-hearth or the crucible process, and must not show more than 0.06% of phosphorus. All castings must be annealed, unless otherwise directed. The tensile strength of steel castings shall be at least 60,000 lbs., with an elongation of at least 15% in 8 in. for all castings for moving parts of machinery, and at least 10% in 8 in. for other castings. Bars 1 in. sq. shall be capable of bending cold, without fracture, through an angle of  $90^\circ$ , over a radius not greater than  $1\frac{1}{2}$  in. All castings must be sound, free from injurious roughness, sponginess, pitting, shrinkage, or other cracks, cavities, etc.

Pennsylvania Railroad specifications, 1888: Steel castings should have a tensile strength of 70,000 lbs. per sq. in. and an elongation of 15% in section originally 2 in. long. Steel castings will not be accepted if tensile strength falls below 60,000 lbs., nor if the elongation is less than 12%, nor if castings have blow-holes and shrinkage cracks. Castings weighing 80 lbs. or more must have cast with them a strip to be used as a test-piece. The dimensions of this strip must be  $\frac{3}{4}$  in. sq. by 12 in. long.

## MECHANICS.

### FORCE, STATICAL MOMENT, EQUILIBRIUM, ETC.

**MECHANICS** is the science that treats of the action of force upon bodies. Statics is the mechanics of bodies at rest relatively to the earth's surface. Dynamics is the mechanics of bodies in motion. Hydrostatics and hydrodynamics are the mechanics of liquids, and Pneumatics the mechanics of air and other gases. These are treated in other chapters.

There are four elementary quantities considered in Mechanics: *Matter, Force, Space, Time.*

**Matter.** — Any substance or material that can be weighed or measured. It exists in three forms: solid, liquid, and gaseous. A definite portion of matter is called a body.

**The Quantity of Matter** in a body may be determined either by measuring its bulk or by weighing it, but as the bulk varies with temperature, with porosity, with size, shape and method of piling its particles, etc., weighing is generally the more accurate method of determining its quantity.

**Weight. Mass.** — The word "weight" is commonly used in two senses: 1. As the measure of quantity of matter in a body, as determined by weighing it in an even balance scale or on a lever or platform scale, and thus comparing its quantity with that of certain pieces of metal called standard weights, such as the pound avoirdupois. 2. As the measure of the force which the attraction of gravitation of the earth exerts on the body, as determined by measuring that force with a spring balance. As the force of gravity varies with the latitude and elevation above sea level of different parts of the earth's surface, the weight determined in this second method is a variable, while that determined by the first method is a constant. For this reason, and also because spring balances are generally not as accurate instruments as even balances, or lever or platform scales, the word "weight," in engineering, unless otherwise specified, means the quantity of matter as determined by weighing it by the first method. The standard unit of weight is the pound.

The word "mass" is used in three senses by writers on physics and engineering: 1. As a general expression of an indefinite quantity, synonymous with lump, piece, portion, etc., as in the expression "a mass whose weight is one pound." 2. As the quotient of the weight, as



determined by the first method of weighing given above, by 32.174, the standard value of  $g$ , the acceleration due to gravity, expressed by the formula  $M = W/g$ . This value is merely the arithmetical ratio of the weight in pounds to the acceleration in feet per second per second, and it has no unit. 3. As a measure of the quantity of matter, exactly synonymous with the first meaning of the word "weight," given above. In this sense the word is used in many books on physics and theoretical mechanics, but it is not so used by engineers. The statement in such books that the engineers' unit of mass is 32.2 lbs. is an error. There is no such unit. Whenever the term "mass" is represented by  $M$  in engineering calculations it is equivalent to  $W/g$ , in which  $W$  is the quantity of matter in pounds, and  $g = 32.1740$  (or 32.2 approximate).

*Local Weight.* — The force, measured in standard pounds of force (see Unit of Force, below), with which gravity attracts a body at a locality other than one where  $g = 32.174$  is sometimes called the "local weight" of the body. It is the weight that would be indicated if the body was weighed on a spring balance calibrated for standard pounds of force. If the balance was calibrated for the particular locality, it would indicate not the local weight, but the true or standard weight, that is, the quantity of matter in pounds or the force that gravity would exert on the body at the standard locality, these being numerically identical. The difference between standard and local weight is rarely large enough to be of importance in engineering problems. In the United States (exclusive of Alaska), the range of the value of  $g$  is only from 0.9973 (at lat. 25°, 10,000 ft. above the sea) to 1.0004 (lat. 49° at the sea level) of the standard value (lat. 45° at the sea level) of 32.1740.

**A Force** is anything that tends to change the state of a body with respect to rest or motion. If a body is at rest, anything that tends to put it in motion is a force; if a body is in motion, anything that tends to change either its direction or its rate of motion is a force.

A force should always mean the pull, pressure, rub, attraction (or repulsion) of one body upon another, and always implies the existence of a simultaneous equal and opposite force exerted by that other body on the first body, i.e., the *reaction*. In no case should we call anything a force unless we can conceive of it as capable of measurement by a spring balance, and are able to say from what other body it comes. (I. P. Church.)

Forces may be divided into two classes, extraneous and molecular; extraneous forces act on bodies from without; molecular forces are exerted between the neighboring particles of bodies.

*Extraneous forces* are of two kinds, pressures and moving forces; pressures simply tend to produce motion; moving forces actually produce motion. Thus, if gravity act on a fixed body, it creates pressure; if on a free body, it produces motion.

*Molecular forces* are of two kinds, attractive and repellent: attractive forces tend to bind the particles of a body together; repellent forces tend to thrust them asunder. Both kinds of molecular forces are continually exerted between the molecules of bodies, and on the predominance of one or the other depends the physical state of a body, as solid, liquid, or gaseous.

**The Unit of Force** used in engineering, by English writers, is the pound avoirdupois. Strictly, it is the force which would give to a pound of matter an acceleration of 32.1740 feet per sec. per sec., or the force with which gravity attracts a pound of matter at 45° latitude at the sea level. In the French C. G. S. or centimeter-gram-second system, the unit of force is the force which acting on a mass of one gram will produce in one second a velocity of one centimeter per second. This unit is called a "dyne" =  $1/980.665$  gram.

An attempt has been made by some writers on physics to introduce the so-called "absolute system" into English weights and measures, and to define the "absolute unit" of force as that force which acting on the mass whose weight is one pound at London will in one second produce a velocity of one foot per second, and they have given this unit the name "poundal." The use of this unit only makes confusion for students, and it is to be hoped that it will soon be abandoned in high-school textbooks. Professor Perry, in his "Calculus for Engineers," p. 26, says,

"One might as well talk Choctaw in the shops as to speak about . . . so many poundals of force and so many foot-poundals of work."\*

**Inertia** is that property of a body by virtue of which it tends to continue in the state of rest or motion in which it may be placed, until acted on by some force.

**Newton's Laws of Motion.**— 1st Law. If a body be at rest, it will remain at rest, or if in motion it will move uniformly in a straight line till acted on by some force.

2d Law. If a body be acted on by several forces, it will obey each as though the others did not exist, and this whether the body be at rest or in motion. (This law is expressed in different forms by various authors. One of these forms is: Change of the motion of a body is proportional to the force and to the time during which the force acts, and is in the same direction as the force.)

3d Law. If a force act to change the state of a body with respect to rest or motion, the body will offer a resistance equal and directly opposed to the force. Or, to every action there is opposed an equal and opposite reaction.

**Graphic Representation of a Force.**— Forces may be represented geometrically by straight lines, proportional to the forces. A force is given when we know its intensity, its point of application, and the direction in which it acts. When a force is represented by a line, the length of the line represents its intensity; one extremity represents the point of application; and an arrow-head at the other extremity shows the direction of the force.

**Composition of Forces** is the operation of finding a single force whose effect is the same as that of two or more given forces. The required force is called the resultant of the given forces.

**Resolution of Forces** is the operation of finding two or more forces whose combined effect is equivalent to that of a given force. The required forces are called components of the given force.

The resultant of two forces applied at a point, and acting in the same direction, is equal to the sum of the forces. If two forces act in opposite directions, their resultant is equal to their difference, and it acts in the direction of the greater.

If any number of forces be applied at a point, some in one direction and others in a contrary direction, their resultant is equal to the sum of those that act in one direction, diminished by the sum of those that act in the opposite direction; or, the resultant is equal to the algebraic sum of the components.

**Parallelogram of Forces.**— If two forces acting on a point be represented in direction and intensity by adjacent sides of a parallelogram, their resultant will be represented by that diagonal of the parallelogram which passes through the point. Thus *OR*, Fig. 99, is the resultant of *OQ* and *OP*.

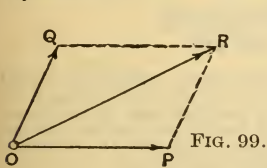

FIG. 99.

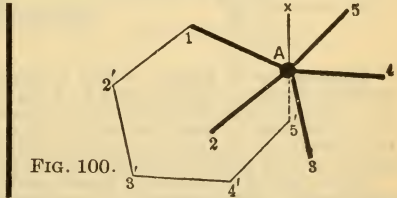

FIG. 100.

**Polygon of Forces.**— If several forces are applied at a point and act in a single plane, their resultant is found as follows:

Through the point draw a line representing the first force; through the

\* Professor Perry himself, however, makes a slip on the same page in saying: "Force in pounds is the space-rate at which work in foot-pounds is done; it is also the time-rate at which momentum is produced or destroyed." He gets this idea, no doubt, from the equations  $FT = MV$ ,  $F = MV/T$ ,  $F = \frac{1}{2} MV^2 \div S$ . Force is not these things: it is merely numerically equivalent, when certain units are chosen, to these last two quotients. We might as well say, since  $T = MV/F$ , that time is the force-rate of momentum.

extremity of this draw a line representing the second force; and so on, throughout the system; finally, draw a line from the starting-point to the extremity of the last line drawn, and this will be the resultant required.

Suppose the body *A*, Fig. 100, to be urged in the directions *A*1, *A*2, *A*3, *A*4, and *A*5 by forces which are to each other as the lengths of those lines. Suppose these forces to act successively and the body to first move from *A* to 1; the second force *A*2 then acts and finding the body at 1 would take it to 2'; the third force would then carry it to 3', the fourth to 4', and the fifth to 5'. The line *A*5' represents in magnitude and direction the resultant of all the forces considered. If there had been an additional force, *A**r*, in the group, the body would be returned by that force to its original position, supposing the forces to act successively, but if they had acted simultaneously the body would never have moved at all; the tendencies to motion balancing each other.

It follows, therefore, that if the several forces which tend to move a body can be represented in magnitude and direction by the sides of a closed polygon taken in order, the body will remain at rest; but if the forces are represented by the sides of an open polygon, the body will move and the direction will be represented by the straight line which closes the polygon.

**Twisted Polygon.**—The rule of the polygon of forces holds true even when the forces are not in one plane. In this case the lines *A*1, 1-2', 2'-3', etc., form a twisted polygon, that is, one whose sides are not in one plane.

**Parallelepipedon of Forces.**—If three forces acting on a point be represented by three edges of a parallelepipedon which meet in a common point, their resultant will be represented by the diagonal of the parallelepipedon that passes through their common point.

Thus *OR*, Fig. 101, is the resultant of *OQ*, *OS* and *OP*. *OM* is the resultant of *OP* and *OQ*, and *OR* is the resultant of *OM* and *OS*.

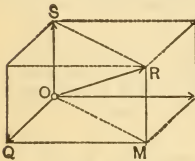

FIG. 101.

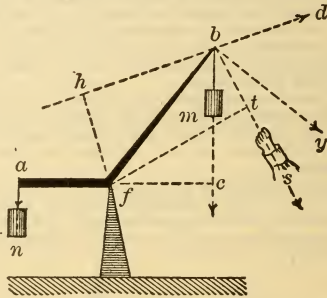

FIG. 102.

**Moment of a Force.**—The moment of a force (sometimes called statical moment), with respect to a point, is the product of the force by the perpendicular distance from the point to the direction of the force. The fixed point is called the center of moments; the perpendicular distance is the lever-arm of the force; and the moment itself measures the tendency of the force to produce rotation about the center of moments.

If the force is expressed in pounds and the distance in feet, the moment is expressed in foot-pounds. It is necessary to observe the distinction between foot-pounds of statical moment and foot-pounds of work or energy. (See Work.)

In the bent lever, Fig. 102 (from Trautwine), if the weights *n* and *m* represent forces, their moments about the point *f* are respectively  $n \times af$  and  $m \times fc$ . If instead of the weight *m* a pulling force to balance the weight *n* is applied in the direction *bs*, or *by* or *bd*, *s*, *y*, and *d* being the amounts of these forces, their respective moments are  $s \times ft$ ,  $y \times fb$ ,  $d \times fh$ .

If the forces acting on the lever are in equilibrium it remains at rest, and the moments on each side of *f* are equal, that is,  $n \times af = m \times fc$ , or  $s \times ft$ , or  $y \times fb$ , or  $d \times fh$ .

The moment of the resultant of any number of forces acting together in



the same plane is equal to the algebraic sum of the moments of the forces taken separately.

**Statical Moment. Stability.** — The statical moment of a body is the product of its weight by the distance of its line of gravity from some assumed line of rotation. The line of gravity is a vertical line drawn from its center of gravity through the body. The stability of a body is that resistance which its weight alone enables it to oppose against forces tending to overturn it or to slide it along its foundation.

To be safe against turning on an edge the moment of the forces tending to overturn it, taken with reference to that edge, must be less than the statical moment. When a body rests on an inclined plane, the line of gravity, being vertical, falls toward the lower edge of the body, and the condition of its not being overturned by its own weight is that the line of gravity must fall within this edge. In the case of an inclined tower resting on a plane the same condition holds — the line of gravity must fall within the base. The condition of stability against sliding along a horizontal plane is that the horizontal component of the force exerted tending to cause it to slide shall be less than the product of the weight of the body into the coefficient of friction between the base of the body and its supporting plane. This coefficient of friction is the tangent of the angle of repose, or the maximum angle at which the supporting plane might be raised from the horizontal before the body would begin to slide. (See Friction.)

**The Stability of a Dam** against overturning about its lower edge is calculated by comparing its statical moment referred to that edge with the resultant pressure of the water against its upper side. The horizontal pressure on a square foot at the bottom of the dam is equal to the weight of a column of water of one square foot in section, and of a height equal to the distance of the bottom below water-level; or, if  $H$  is the height, the pressure at the bottom per square foot =  $62.4 \times H$  lbs. At the water-level the pressure is zero, and it increases uniformly to the bottom, so that the sum of the pressures on a vertical strip one foot in breadth may be represented by the area of a triangle whose base is  $62.4 \times H$  and whose altitude is  $H$ , or  $62.4 H^2 \div 2$ . The center of gravity of a triangle being  $\frac{1}{3}$  of its altitude, the resultant of all the horizontal pressures may be taken as equivalent to the sum of the pressures acting at  $\frac{1}{3} H$ , and the moment of the sum of the pressures is therefore  $62.4 \times H^3 \div 6$ .

**Parallel Forces.** — If two forces are parallel and act in the same direction, their resultant is parallel to both, and lies between them, and the intensity of the resultant is equal to the sum of the intensities of the two forces. Thus in Fig. 102 the resultant of the forces  $n$  and  $m$  acts vertically downward at  $f$ , and is equal to  $n + m$ .

If two parallel forces act at the extremities of a straight line and in the same direction, the resultant divides the line joining the points of

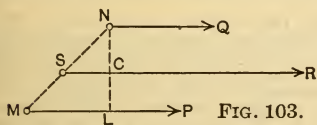

FIG. 103.

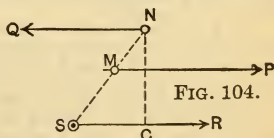

FIG. 104.

application of the components, inversely as the components. Thus in Fig. 102  $m : n :: af : fc^2$  and in Fig. 103,  $P : Q :: SN : SM$ .

The resultant of two parallel forces acting in opposite directions is parallel to both, lies without both, on the side and in the direction of the greater, and its intensity is equal to the difference of the intensities of the two forces.

Thus the resultant of the two forces  $Q$  and  $P$ , Fig. 104, is equal to  $Q - P = R$ . Of any two parallel forces and their resultant each is proportional to the distance between the other two; this in both Figs. 103 and 104,  $P : Q : R :: SN : SM : MN$ .

**Couples.** — If  $P$  and  $Q$  be equal and act in opposite directions,  $R = 0$ ; that is, they have no resultant. Two such forces constitute a couple.

The tendency of a couple is to produce rotation; the measure of this tendency, called *the moment of the couple*, is the product of one of the forces by the distance between the two.

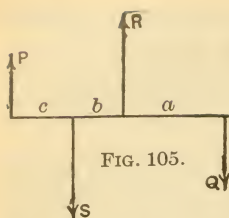

FIG. 105.

Since a couple has no single resultant, no single force can balance a couple. To prevent the rotation of a body acted on by a couple the application of two other forces is required, forming a second couple. Thus in Fig. 105,  $P$  and  $Q$ , forming a couple, may be balanced by a second couple formed by  $R$  and  $S$ . The point of application of either  $R$  or  $S$  may be a fixed pivot or axis.

Moment of the couple  $PQ = P(c + b + a) =$  moment of  $RS = Rb$ . Also,  $P + R = Q + S$ .

The forces  $R$  and  $S$  need not be parallel to  $P$  and  $Q$ , but if not, then their components parallel to  $PQ$  are to be taken instead of the forces themselves.

**Equilibrium of Forces.**—A system of forces applied at points of a solid body will be equilibrium when they have no tendency to produce motion, either of translation or of rotation.

The conditions of equilibrium are: 1. The algebraic sum of the components of the forces in the direction of any three rectangular axes must separately equal 0. 2. The algebraic sum of the moments of the forces, with respect to any three rectangular axes, must separately equal 0.

If the forces lie in a plane: 1. The algebraic sum of the components of the forces, in the direction of any two rectangular axes, must be separately equal to 0. 2. The algebraic sum of the moments of the forces, with respect to any point in the plane, must be equal to 0.

If a body is restrained by a fixed axis, as in case of a pulley, or wheel and axle, the forces will be in equilibrium when the algebraic sum of the moments of the forces with respect to the axis is equal to 0.

### CENTER OF GRAVITY.

The center of gravity of a body, or of a system of bodies rigidly connected together, is that point about which, if suspended, all the parts will be in equilibrium, that is, there will be no tendency to rotation. It is the point through which passes the resultant of the efforts of gravitation on each of the elementary particles of a body. In bodies of equal heaviness throughout, the center of gravity is the center of magnitude.

(The center of magnitude of a figure is a point such that if the figure be divided into equal parts the distance of the center of magnitude of the whole figure from any given plane is the mean of the distances of the centers of magnitude of the several equal parts from that plane.)

A body suspended at its center of gravity is in equilibrium in all positions. If suspended at a point outside of its center of gravity, it will take a position so that its center of gravity is vertically below its point of suspension.

To find the center of gravity of any plane figure mechanically, suspend the figure by any point near its edge, and mark on it the direction of a plumb-line hung from that point; then suspend it from some other point, and again mark the direction of the plumb-line in like manner. The center of gravity will be at the intersection of the two marks.

**The Center of Gravity of Regular Figures**, whether plane or solid, is the same as their geometrical center; for instance, a straight line, parallelogram, regular polygon, circle, circular ring, prism, cylinder, sphere, spheroid, middle frustums of spheroid, etc.

*Of a triangle:* On a line drawn from any angle to the middle of the opposite side, at a distance of one-third of the line from the side; or at the intersection of such lines drawn from any two angles.

*Of a trapezium or trapezoid:* Draw a diagonal, dividing it into two triangles. Draw a line joining their centers of gravity. Draw the other diagonal, making two other triangles, and a line joining their centers of gravity. The intersection of the two lines is the center of gravity.

*Of a sector of a circle:* On the radius which bisects the arc,  $2cr \div 3l$  from the center,  $c$  being the chord,  $r$  the radius, and  $l$  the arc.

*Of a semicircle:* On the middle radius,  $0.4244 r$  from the center.

*Of a quadrant:* On the middle radius,  $0.600 r$  from the center.

*Of a segment of a circle:*  $c^3 \div 12a$  from the center.  $c =$  chord,  $a =$  area.

*Of a parabolic surface:* In the axis,  $\frac{3}{5}$  of its length from the vertex.

*Of a semi-parabola (surface):*  $\frac{3}{5}$  length of the axis from the vertex, and  $\frac{3}{8}$  of the semi-base from the axis.

*Of a cone or pyramid:* In the axis,  $\frac{1}{4}$  of its length from the base.

*Of a paraboloid:* In the axis,  $\frac{2}{3}$  of its length from the vertex.

*Of a cylinder, or regular prism:* In the middle point of the axis.

*Of a frustum of a cone or pyramid:* Let  $a$  = length of a line drawn from the vertex of the cone when complete to the center of gravity of the base, and  $a'$  that portion of it between the vertex and the top of the frustum; then distance of center of gravity of the frustum from center of gravity of

$$\text{its base} = \frac{a}{4} - \frac{3a'^3}{4(a^2 + aa' + a'^2)}$$

*For two bodies,* fixed one at each end of a straight bar, the common center of gravity is in the bar, at that point which divides the distance between their respective centers of gravity in the inverse ratio of the weights. In this solution the weight of the bar is neglected. But it may be taken as a third body, and allowed for as in the following directions:

For more than two bodies connected in one system: Find the common center of gravity of two of them; and find the common center of these two jointly with a third body, and so on to the last body of the group.

*Another method,* by the principle of moments: To find the center of gravity of a system of bodies, or a body consisting of several parts, whose several centers are known. If the bodies are in a plane, refer their several centers to two rectangular coördinate axes. Multiply each weight by its distance from one of the axes, add the products, and divide the sum by the sum of the weights; the result is the distance of the center of gravity from that axis. Do the same with regard to the other axis. If the bodies are not in a plane, refer them to three planes at right angles to each other, and determine the mean distance of the sum of the weights from each plane.

**MOMENT OF INERTIA.**

The moment of inertia of the weight of a body with respect to an axis is the algebraic sum of the products of the weight of each elementary particle by the square of its distance from the axis. If the moment of inertia with respect to any axis =  $I$ , the weight of any element of the body =  $w$ , and its distance from the axis =  $r$ , we have  $I = \sum(wr^2)$ .

The moment of inertia varies, in the same body, according to the position of the axis. It is the least possible when the axis passes through the center of gravity. To find the moment of inertia of a body, referred to a given axis, divide the body into small parts of regular figure. Multiply the weight of each part by the square of the distance of its center of gravity from the axis. The sum of the products is the moment of inertia. The value of the moment of inertia thus obtained will be more nearly exact, the smaller and more numerous the divisions of the body.

**MOMENTS OF INERTIA OF REGULAR SOLIDS.** — Rod, or bar, of uniform thickness, with respect to an axis perpendicular to the length of the rod,

$$I = W \left( \frac{l^2}{3} + d^2 \right), \dots \dots \dots (1)$$

$W$  = weight of rod,  $2l$  = length,  $d$  = distance of center of gravity from axis.

Thin circular plate, axis in its own plane, }  $I = W \left( \frac{r^2}{4} + d^2 \right), \dots \dots \dots (2)$

$r$  = radius of plate.  
Circular plate, axis perpendicular to the plate, }  $I = W \left( \frac{r^2}{2} + d^2 \right) \dots \dots \dots (3)$

Circular ring, axis perpendicular to its own plane, }  $I = W \left( \frac{r^2 + r'^2}{2} + d^2 \right), \dots \dots (4)$

$r$  and  $r'$  are the exterior and interior radii of the ring.  
Cylinder, axis perpendicular to the axis of the cylinder. }  $I = W \left( \frac{r^2}{4} + \frac{l^2}{3} + d^2 \right) \dots \dots (5)$

$r$  = radius of base.  $2l$  = length of the cylinder.

By making  $d = 0$  in any of the above formulæ, we find the moment of inertia for a parallel axis through the center of gravity.

The moment of inertia,  $\sum wr^2$ , numerically equals the weight of a body which, if concentrated at the distance unity from the axis of rotation, would require the same work to produce a given increase of angular velocity that the actual body requires. It bears the same relation to angular acceleration which weight does to linear acceleration (Rankine). The term moment of inertia is also used in regard to areas, as the cross-



sections of] beams under strain. In this case  $I = \Sigma ar^2$ ,  $a$  being any elementary area, and  $r$  its distance from the center. (See Strength of Materials, p. 293.) Some writers call  $\Sigma mr^2 = \Sigma ur^2 \div g$  the moment of inertia.

### CENTERS OF OSCILLATION AND OF PERCUSSION.

**Center of Oscillation.** — If a body oscillate about a fixed horizontal axis, not passing through its center of gravity, there is a point in the line drawn from the center of gravity perpendicular to the axis whose motion is the same as it would be if the whole mass were collected at that point and allowed to vibrate as a pendulum about the fixed axis. This point is called the center of oscillation.

**The Radius of Oscillation,** or distance of the center of oscillation from the point of suspension = the square of the radius of gyration  $\div$  distance of the center of gravity from the point of suspension or axis. The centers of oscillation and suspension are convertible.

If a straight line, or uniform thin bar or cylinder, be suspended at one end, oscillating about it as an axis, the center of oscillation is at  $\frac{2}{3}$  the length of the rod from the axis. If the point of suspension is at  $\frac{1}{3}$  the length from the end, the center of oscillation is also at  $\frac{2}{3}$  the length from the axis, that is, it is at the other end. In both cases the oscillation will be performed in the same time. If the point of suspension is at the center of gravity, the length of the equivalent simple pendulum is infinite, and therefore the time of vibration is infinite.

For a sphere suspended by a cord,  $r$  = radius,  $h$  = distance of axis of motion from the center of the sphere,  $h'$  = distance of center of oscillation from center of sphere,  $l$  = radius of oscillation =  $h + h' = h + \frac{2}{5}(r^2 \div h)$ .

If the sphere vibrate about an axis tangent to its surface,  $h = r$ , and  $l = r + \frac{2}{5}r$ . If  $h = 10r$ ,  $l = 10r + (r \div 25)$ .

Lengths of the radius of oscillation of a few regular plane figures or thin plates, suspended by the vertex or uppermost point.

1st. When the vibrations are perpendicular to the plane of the figure:

In an isosceles triangle the radius of oscillation is equal to  $\frac{3}{4}$  of the height of the triangle.

In a circle,  $\frac{5}{8}$  of the diameter.

In a parabola,  $\frac{5}{7}$  of the height.

2d. When the vibrations are edgewise, or in the plane of the figure:

In a circle the radius of oscillation is  $\frac{3}{4}$  of the diameter.

In a rectangle suspended by one angle,  $\frac{2}{3}$  of the diagonal.

In a parabola, suspended by the vertex,  $\frac{5}{7}$  of the height plus  $\frac{1}{3}$  of the parameter.

In a parabola, suspended by the middle of the base,  $\frac{4}{7}$  of the height plus  $\frac{1}{2}$  the parameter.

**Center of Percussion.** — The center of percussion of a body oscillating about a fixed axis is the point at which, if a blow is struck by the body, the percussive action is the same as if the whole mass of the body were concentrated at the point. It is identical with the center of oscillation.

### CENTER AND RADIUS OF GYRATION.

The center of gyration, with reference to an axis, is a point at which, if the entire weight of a body be concentrated, its moment of inertia will remain unchanged; or, in a revolving body, the point in which the whole weight of the body may be conceived to be concentrated, as if a pound of platinum were substituted for a pound of revolving feathers, the angular velocity and the accumulated work remaining the same. The distance of this point from the axis is the *radius of gyration*. If  $W$  = the weight of a body,  $I = \Sigma wr^2$  = its moment of inertia, and  $k$  = its radius of gyration,

$$I = Wk^2 = \Sigma wr^2; \quad k = \sqrt{\frac{\Sigma wr^2}{W}}$$

The moment of inertia = the weight  $\times$  the square of the radius of gyration.

To find the radius of gyration divide the body into a considerable number of equal small parts, — the more numerous the more nearly exact is the result, — then take the mean of all the squares of the distances of the parts from the axis of revolution, and find the square root of the mean square. Or, if the moment of inertia is known, divide it by the weight and extract the square root. For radius of gyration of an area, divide the moment of inertia of the area by the area and extract the square root.

The radius of gyration is the least possible when the axis passes through the center of gravity. This minimum radius is called the principal radius of gyration. If we denote it by  $k$  and any other radius of gyration by  $k'$ , we have for the five cases given under the head of moment of inertia above the following values:

- (1) Rod, axis perpen. to length,  $\left. \begin{array}{l} \end{array} \right\} k = l \sqrt{\frac{1}{3}}; k' = \sqrt{\frac{l^2}{3} + d^2}.$
- (2) Circular plate, axis in its plane,  $\left. \begin{array}{l} \end{array} \right\} k = \frac{r}{2}; k' = \sqrt{\frac{r^2}{4} + d^2}.$
- (3) Circular plate, axis perpen. to plane,  $\left. \begin{array}{l} \end{array} \right\} k = r \sqrt{\frac{1}{2}}; k' = \sqrt{\frac{r^2}{2} + d^2}.$
- (4) Circular ring, axis perpen. to plane,  $\left. \begin{array}{l} \end{array} \right\} k = \sqrt{\frac{r^2 + r'^2}{2}}; k' = \sqrt{\frac{r^2 + r'^2}{2} + d^2}.$
- (5) Cylinder, axis perpen. to length,  $\left. \begin{array}{l} \end{array} \right\} k = \sqrt{\frac{r^2}{4} + \frac{l^2}{3}}; k' = \sqrt{\frac{r^2}{4} + \frac{l^2}{3} + d^2}.$

**Principal Radii of Gyration and Squares of Radii of Gyration.**

(For radii of gyration of sections of columns, see page 295.)

Surface or Solid.	Rad. of Gyration.	Square of R. of Gyration.
Parallelogram: } axis at its base.....	0.5773 $h$	$\frac{1}{3} h^2$
height $h$ } " mid-height.....	0.2886 $h$	$\frac{1}{12} h^2$
Straight rod: } axis at end.....	0.5773 $l$	$\frac{1}{3} l^2$
length $l$ , or thin } " mid-length.....	0.2886 $l$	$\frac{1}{12} l^2$
rectang. plate }		
Rectangular prism: axes $2a, 2b, 2c$ , referred to axis $2a$ .....	$0.577 \sqrt{b^2 + c^2}$	$(b^2 + c^2) \div 3$
Parallelepiped: length $l$ , base $b$ , axis at one end, at mid-breadth.....	$0.289 \sqrt{4l^2 + b^2}$	$\frac{4l^2 + b^2}{12}$
Hollow square tube: out. side $h$ , inner $h'$ , axis mid-length....	$0.289 \sqrt{h^2 + h'^2}$	$(h^2 + h'^2) \div 12$
very thin, side = $h$ , axis mid-length....	$.408 h$	$h^2 \div 6$
Thin rectangular tube: sides $b, h$ , axis mid-length.....	$0.289 h \sqrt{\frac{h + 3b}{h + b}}$	$\frac{h^2 \cdot h + 3b}{12 \cdot h + b}$
Thin circ. plate: rad. $r$ , diam. $h$ , ax. diam. Flat circ. ring: diams. $h, h'$ , axis diam....	$\frac{1}{4} \sqrt{h^2 + h'^2}$	$\frac{1}{4} r^2 = \frac{h^2 + 16}{(h^2 + h'^2) \div 16}$
Solid circular cylinder: length $l$ , axis diameter at mid-length.....	$0.289 \sqrt{l^2 + 3r^2}$	$\frac{l^2}{12} + \frac{r^2}{4}$
Circular plate: solid wheel of uniform thickness, or cylinder of any length, referred to axis of cyl.....	0.7071 $r$	$\frac{1}{2} r^2$
Hollow circ. cylinder, or flat ring: $l$ , length; $R, r$ , outer and inner radii. Axis, 1, longitudinal axis; 2, diam. at mid-length.....	$0.7071 \sqrt{R^2 + r^2}$ $.289 \sqrt{l^2 + 3(R^2 + r^2)}$	$\frac{(R^2 + r^2) \div 2}{l^2 + \frac{R^2 + r^2}{12}}$
Same: very thin, axis its diameter.....	$0.289 \sqrt{l^2 + 6R^2}$	$\frac{l^2}{12} + \frac{R^2}{2}$
" radius $r$ ; axis, longitudinal axis....	$r$	$r^2$
Circumf. of circle, axis its center.....	$\frac{r}{2}$	$\frac{r^2}{4}$
Sphere: radius $r$ , axis its diam.....	0.7071 $r$	$\frac{1}{2} r^2$
Spheroid: equatorial radius $r$ , revolving polar axis $a$ .....	0.6325 $r$	$\frac{2}{5} r^2$
Paraboloid: $r$ =rad. of base, rev. on axis.	0.5773 $r$	$\frac{1}{3} r^2$
Ellipsoid: semi-axes $a, b, c$ ; revolving on axis $2a$ .....	0.4472 $\sqrt{b^2 + c^2}$	$\frac{b^2 + c^2}{5}$
Spherical shell: radii $R, r$ , revolving on its diam.....	$0.6325 \sqrt{R^5 - r^5}$ $\sqrt{R^3 - r^3}$	$\frac{2R^5 - r^5}{5R^3 - r^3}$
Same: very thin, radius $r$ .....	0.8165 $r$	$\frac{2}{3} r^2$
Solid cone: $r$ =rad. of base, rev. on axis....	0.5477 $r$	$0.3 r^2$

## THE PENDULUM.

A body of any form suspended from a fixed axis about which it oscillates by the force of gravity is called a *compound pendulum*. The ideal body concentrated at the center of oscillation, suspended from the center of suspension by a string without weight, is called a *simple pendulum*. This equivalent simple pendulum has the same weight as the given body, and also the same moment of inertia, referred to an axis passing through the point of suspension, and it oscillates in the same time.

The ordinary pendulum of a given length vibrates in equal times when the angle of the vibrations does not exceed 4 or 5 degrees, that is,  $2^\circ$  or  $2\frac{1}{2}^\circ$  each side of the vertical. This property of a pendulum is called its isochronism.

The time of vibration of a pendulum varies directly as the square root of the length, and inversely as the square root of the acceleration due to gravity at the given latitude and elevation above the earth's surface.

If  $T$  = the time of vibration,  $l$  = length of the simple pendulum,  $g$  = the acceleration, then  $T = \pi \sqrt{\frac{l}{g}}$ ; since  $\pi$  is constant  $T \propto \frac{\sqrt{l}}{\sqrt{g}}$ . At a given location  $g$  is constant and  $T \propto \sqrt{l}$ . If  $l$  be constant, then for any location  $T \propto \frac{1}{\sqrt{g}}$ . If  $T$  be constant,  $g T^2 = \pi^2 l$ ;  $l \propto g$ ;  $g = \frac{\pi^2 l}{T^2}$ . From this equation the force of gravity at any place may be determined if the length of the simple pendulum, vibrating seconds, at that place is known. At New York this length is 39.1017 inches = 3.2585 ft., whence  $g = 32.16$  ft.

Time of vibration of a pendulum of a given length at New York

$$= t = \sqrt{\frac{l}{39.1017}} = \frac{\sqrt{l}}{6.253},$$

$t$  being in seconds and  $l$  in inches. Length of a pendulum having a given time of vibration,  $l = t^2 \times 39.1017$  inches.

The time of vibration of a pendulum may be varied by the addition of a weight at a point above the center of suspension, which counteracts the lower weight, and lengthens the period of vibration. By varying the height of the upper weight the time is varied.

To find the weight of the upper bob of a compound pendulum, vibrating seconds, when the weight of the lower bob and the distances of the weights from the point of suspension are given:

$$w = W \frac{(39.1 \times D) - D^2}{(39.1 \times d) + d^2}.$$

$W$  = the weight of the lower bob,  $w$  = the weight of the upper bob;  $D$  = the distance of the lower bob, and  $d$  = the distance of the upper bob from the point of suspension, in inches.

Thus, by means of a second bob, short pendulums may be constructed to vibrate as slowly as longer pendulums.

By increasing  $w$  or  $d$  until the lower weight is entirely counterbalanced the time of vibration may be made infinite.

**Conical Pendulum.**—A weight suspended by a cord and revolving at a uniform speed in the circumference of a circular horizontal plane whose radius is  $r$ , the distance of the plane below the point of suspension being  $h$ , is held in equilibrium by three forces — the tension in the cord, the centrifugal force, which tends to increase the radius  $r$ , and the force of gravity acting downward. If  $v$  = the velocity in feet per second of the center of gravity of the weight, as it describes the circumference,  $g = 32.16$ , and  $r$  and  $h$  are taken in feet, the time in seconds of performing one revolution is (at New York or other place where  $g = 32.16$ )

$$t = \frac{2\pi r}{v} = 2\pi \sqrt{\frac{h}{g}}; \quad h = \frac{gt^2}{4\pi^2} = 0.8146 t^2.$$

If  $t = 1$  second,  $h = 0.8146$  foot = 9.775 inches.

The principle of the conical pendulum is used in the ordinary fly-ball governor for steam-engines. (See Governors.)



**CENTRIFUGAL FORCE.**

A body revolving in a curved path of radius =  $R$  in feet exerts a force, called centrifugal force,  $F$ , upon the arm or cord which restrains it from moving in a straight line, or "flying off at a tangent." If  $W$  = weight of the body in pounds,  $N$  = number of revolutions per minute,  $v$  = linear velocity of the center of gravity of the body, in feet per second,  $g = 32.174$ , then

$$v = \frac{2\pi RN}{60}; F = \frac{Wv^2}{gR} = \frac{Wv^2}{32.174 R} = \frac{W4\pi^2 RN^2}{3600 g} = \frac{WRN^2}{2933.9} = .00034084 WRN^2 \text{ lbs.}$$

If  $n$  = number of revolutions per second,  $F = 1.2270 WRn^2$ .  
(For centrifugal force in fly-wheels, see Fly-wheels.)

**VELOCITY, ACCELERATION, FALLING BODIES.**

**Velocity** is the rate of motion, or the speed of a body at any instant.

If  $s$  = space in feet passed over in  $t$  seconds, and  $v$  = velocity in feet per second, if the velocity is uniform,

$$v = \frac{s}{t}; s = vt; t = \frac{s}{v}$$

If the velocity varies uniformly, the mean velocity  $v_m = 1/2(v_1 + v_2)$ , in which  $v_1$  is the velocity at the beginning and  $v_2$  the velocity at the end of the time  $t$ .

$$s = 1/2(v_1 + v_2)t \dots \dots \dots (1)$$

If  $v_1 = 0$ , then  $s = 1/2 v_2 t$ .  $v_2 = 2 s/t$ .

If the velocity varies, but not uniformly,  $v$  for an exceedingly short interval of time =  $s/t$ , or in calculus  $v = ds/dt$ .

**Acceleration** is the change in velocity which takes place in a unit of time. Unit of acceleration =  $a = 1$  foot per second in one second. For uniformly varying velocity, the acceleration is a constant quantity, and

$$a = \frac{v_2 - v_1}{t}; v_2 = v_1 + at; v_1 = v_2 - at; t = \frac{v_2 - v_1}{a} \dots \dots (2)$$

If the body start from rest,  $v_1 = 0$ ; then if  $v_m$  = mean velocity

$$v_m = \frac{v_2}{2}; v_2 = 2 v_m; a = \frac{v_2}{t}; v_2 = at; v_2 - at = 0; t = \frac{v_2}{a}$$

$$t = \frac{v}{g} = \frac{v}{32.16} = \sqrt{\frac{2h}{g}} = \frac{\sqrt{h}}{4.01} = \frac{2h}{v}$$

$u$  = space fallen through in the  $T$ th second =  $g(T - 1/2)$ .

If  $v_1 = 0$ ,  $s = 1/2 v_2 t$ .

**Retarded Motion.** — If the body start with a velocity  $v_1$  and come to rest,  $v_2 = 0$ ; then  $s = 1/2 v_1 t$ .

In any case, if the change in velocity is  $v$ ,

$$s = \frac{v}{2} t; s = \frac{v^2}{2a}; s = \frac{a}{2} t^2$$

For a body starting from or ending at rest, we have the equations

$$v = at; s = \frac{v}{2} t; s = \frac{at^2}{2}; v^2 = 2 as$$

**Falling Bodies.** — In the case of falling bodies the acceleration due to gravity, at 40° latitude, is 32.16 feet per second in one second, =  $g$ . Then if  $v$  = velocity acquired at the end of  $t$  seconds, or final velocity, and  $h$  = height or space in feet passed over in the same time,

$$v = gt = 32.16 t = \sqrt{2gh} = 8.02 \sqrt{h} = \frac{2h}{t};$$

$$h = \frac{gt^2}{2} = 16.08 t^2 = \frac{v^2}{2g} = \frac{v^2}{64.32} = \frac{vt}{2}$$

$$t = \frac{v}{g} = \frac{v}{32.16} = \sqrt{\frac{2h}{g}} = \frac{\sqrt{h}}{4.01} = \frac{2h}{v}$$

$u$  = space fallen through in the  $T$ th second =  $g(T - 1/2)$ .

From the above formulæ for falling bodies we obtain the following:

During the first second the body starting from a state of rest (resistance of the air neglected) falls  $g \div 2 = 16.08$  feet; the acquired velocity is  $g = 32.16$  ft. per sec.; the distance fallen in two seconds is  $h = \frac{gt^2}{2} = 16.08 \times 4 = 64.32$  ft.; and the acquired velocity is  $v = gt = 64.32$  ft. The acceleration, or increase of velocity in each second, is constant, and is 32.16 ft. per second. Solving the equations for different times, we find for

Seconds, $t$ .....		1	2	3	4	5	6
Acceleration, $g$ .....	$32.16 \times$	1	1	1	1	1	1
Velocity acquired at end of time, $v$ ....	$32.16 \times$	1	2	3	4	5	6
Height of fall in each second, $u$ .. .....	$\frac{32.16}{2} \times$	1	3	5	7	9	11

Total height of fall,  $h$  .....  $32.16 \div 2 \times$  1 4 9 16 25 36

**Value of  $g$ .**—The value of  $g$  increases with the latitude, and decreases with the elevation. At the latitude of Philadelphia,  $40^\circ$ , its value is 32.16. At the sea-level, Everett gives  $g = 32.173 - .082 \cos 2 \text{ lat.} - .000003$  height in feet.

At lat.  $45^\circ$  Everett's formula gives  $g = 32.173$ . The value given by the International Conference on Weights and Measures, Paris, 1901, is 32.1740.

Values of  $\sqrt{2g}$ , calculated by an equation given by C. S. Pierce, are given in a table in Smith's Hydraulics, from which we take the following:

Latitude.....	$0^\circ$	$10^\circ$	$20^\circ$	$30^\circ$	$40^\circ$	$50^\circ$	$60^\circ$
Value of $\sqrt{2g}$ ..	8.0112	8.0118	8.0137	8.0165	8.0199	8.0235	8.0269
Value of $g$ ....	32.090	32.094	32.105	32.132	32.160	32.189	32.216

The value of  $\sqrt{2g}$  decreases about .0004 for every 1000 feet increase in elevation above the sea-level.

For all ordinary calculations for the United States,  $g$  is generally taken at 32.16, and  $\sqrt{2g}$  at 8.02. In England  $g = 32.2$ ,  $\sqrt{2g} = 8.025$ . Practical limiting values of  $g$  for the United States, according to Pierce, are:

Latitude $49^\circ$ at sea-level.....	$g = 32.186$
" $25^\circ$ 10,000 feet above the sea.....	$g = 32.089$

Local values of  $g$  are used in the calculation of problems that involve local gravitational force, such as those of falling bodies, lifting loads, and power of waterfalls. In all cases in which  $g$  appears in an equation as a divisor of  $w$  (standard weight in pounds), as in the equation for centrifugal force on the preceding page, the value 32.174 should be used.

Fig. 106 represents graphically the velocity, space, etc., of a body falling for six seconds. The vertical line at the left is the time in seconds, the horizontal lines represent the acquired velocities at the end of each second =  $32.16t$ . The area of the small triangle at the top represents the height fallen through in the first second =  $\frac{1}{2}gt = 16.08$  feet, and each of the other triangles is an equal space. The number of triangles between each pair of horizontal lines represents the height of fall in each second, and the number of triangles between any horizontal line and the top is the total height fallen during the time. The figures under  $h$ ,  $u$  and  $v$  adjoining the cut are to be multiplied by 16.08 to obtain the actual velocities and heights for the given times.

**Angular and Linear Velocity of a Turning Body.**— Let  $r$  = radius of a turning body in feet,  $n$  = number of revolutions per minute,  $v$  = linear velocity of a point on the circumference in feet per second, and  $60v$  = velocity in feet per minute.

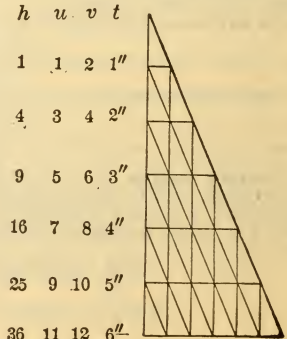

FIG. 106.

$$v = \frac{2\pi rn}{60}; \quad 60v = 2\pi rn.$$

Angular velocity is a term used to denote the angle through which any radius of a body turns in a second, or the rate at which any point in it having a radius equal to unity is moving, expressed in feet per second. The unit of angular velocity is the angle which at a distance = radius from the center is subtended by an arc equal to the radius. This unit angle =  $\frac{180}{\pi}$  degrees = 57.3°.  $2\pi \times 57.3^\circ = 360^\circ$ , or the circumference.

If  $A$  = angular velocity,  $v = Ar$ ,  $A = \frac{v}{r} = \frac{2\pi n}{60}$ . The unit angle  $\frac{180}{\pi}$  is called a *radian*.

**Height Corresponding to a Given Acquired Velocity.**

Velocity.	Height.	Velocity.	Height.	Velocity.	Height.	Velocity.	Height.	Velocity.	Height.	Velocity.	Height.
feet per sec.	feet.	feet per sec.	feet.	feet per sec.	feet.	feet per sec.	feet.	feet per sec.	feet.	feet per sec.	feet.
.25	0.0010	13	2.62	34	17.9	55	47.0	76	89.8	97	146
.50	0.0039	14	3.04	35	19.0	56	48.8	77	92.2	98	149
.75	0.0087	15	3.49	36	20.1	57	50.5	78	94.6	99	152
1.00	0.016	16	3.98	37	21.3	58	52.3	79	97.0	100	155
1.25	0.024	17	4.49	38	22.4	59	54.1	80	99.5	105	171
1.50	0.035	18	5.03	39	23.6	60	56.0	81	102.0	110	188
1.75	0.048	19	5.61	40	24.9	61	57.9	82	104.5	115	205
2	0.062	20	6.22	41	26.1	62	59.8	83	107.1	120	224
2.5	0.097	21	6.85	42	27.4	63	61.7	84	109.7	130	263
3	0.140	22	7.52	43	28.7	64	63.7	85	112.3	140	304
3.5	0.190	23	8.21	44	30.1	65	65.7	86	115.0	150	350
4	0.248	24	8.94	45	31.4	66	67.7	87	117.7	175	476
4.5	0.314	25	9.71	46	32.9	67	69.8	88	120.4	200	622
5	0.388	26	10.5	47	34.3	68	71.9	89	123.2	300	1399
6	0.559	27	11.3	48	35.8	69	74.0	90	125.9	400	2488
7	0.761	28	12.2	49	37.3	70	76.2	91	128.7	500	3887
8	0.994	29	13.1	50	38.9	71	78.4	92	131.6	600	5597
9	1.26	30	14.0	51	40.4	72	80.6	93	134.5	700	7618
10	1.55	31	14.9	52	42.0	73	82.9	94	137.4	800	9952
11	1.88	32	15.9	53	43.7	74	85.1	95	140.3	900	12,593
12	2.24	33	16.9	54	45.3	75	87.5	96	143.3	1000	15,547

**Parallelogram of Velocities.** — The principle of the composition and resolution of forces may also be applied to velocities or to distances moved in given intervals of time. Referring to Fig. 99, page 513, if a body at  $O$  has a force applied to it which acting alone would give it a velocity represented by  $OQ$  per second, and at the same time it is acted on by another force which acting alone would give it a velocity  $OP$  per second, the result of the two forces acting together for one second will carry it to  $R$ ,  $OR$  being the diagonal of the parallelogram of  $OQ$  and  $OP$ , and the resultant velocity. If the two component velocities are uniform, the resultant will be uniform and the line  $OR$  will be a straight line; but if either velocity is a varying one, the line will be a curve. Fig. 107 shows the resultant velocities, also the path traversed by a body acted on by two forces, one of which would carry it at a uniform velocity over the intervals 1, 2, 3,  $B$  and the other of which would carry it by an accelerated motion over the intervals  $a$ ,  $b$ ,  $c$ ,  $D$  in the same times. **At**

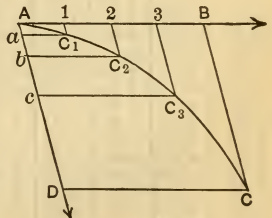

FIG. 107.



**Falling Bodies: Velocity Acquired by a Body Falling a Given Height.**

Height.	Velocity.	Height.	Velocity.	Height.	Velocity.	Height.	Velocity.	Height.	Velocity.	Height.	Velocity.
feet.	feet p.sec.	feet.	feet p.sec.	feet.	feet p.sec.	feet.	feet p.sec.	feet.	feet p.sec.	feet.	feet p.sec.
0.005	.57	0.39	5.01	1.20	8.79	5.	17.9	23.	38.5	72	68.1
0.010	.80	0.40	5.07	1.22	8.87	.2	18.3	.5	38.9	73	68.5
0.015	.98	0.41	5.14	1.24	8.94	.4	18.7	24.	39.3	74	69.0
0.020	1.13	0.42	5.20	1.26	9.01	.6	19.0	.5	39.7	75	69.5
0.025	1.27	0.43	5.26	1.28	9.08	.8	19.3	25.	40.1	76	69.9
0.030	1.39	0.44	5.32	1.30	9.15	6.	19.7	26.	40.9	77	70.4
0.035	1.50	0.45	5.38	1.32	9.21	.2	20.0	27.	41.7	78	70.9
0.040	1.60	0.46	5.44	1.34	9.29	.4	20.3	28.	42.5	79	71.3
0.045	1.70	0.47	5.50	1.36	9.36	.6	20.6	29.	43.2	80	71.8
0.050	1.79	0.48	5.56	1.38	9.43	.8	20.9	30.	43.9	81	72.2
0.055	1.88	0.49	5.61	1.40	9.49	7.	21.2	31.	44.7	82	72.6
0.060	1.97	0.50	5.67	1.42	9.57	.2	21.5	32.	45.4	83	73.1
0.065	2.04	0.51	5.73	1.44	9.62	.4	21.8	33.	46.1	84	73.5
0.070	2.12	0.52	5.78	1.46	9.70	.6	22.1	34.	46.8	85	74.0
0.075	2.20	0.53	5.84	1.48	9.77	.8	22.4	35.	47.4	86	74.4
0.080	2.27	0.54	5.90	1.50	9.82	8.	22.7	36.	48.1	87	74.8
0.085	2.34	0.55	5.95	1.52	9.90	.2	23.0	37.	48.8	88	75.3
0.090	2.41	0.56	6.00	1.54	9.96	.4	23.3	38.	49.4	89	75.7
0.095	2.47	0.57	6.06	1.56	10.0	.6	23.5	39.	50.1	90	76.1
0.100	2.54	0.58	6.11	1.58	10.1	.8	23.8	40.	50.7	91	76.5
0.105	2.60	0.59	6.16	1.60	10.2	9.	24.1	41.	51.4	92	76.9
0.110	2.66	0.60	6.21	1.65	10.3	.2	24.3	42.	52.0	93	77.4
0.115	2.72	0.62	6.32	1.70	10.5	.4	24.6	43.	52.6	94	77.8
0.120	2.78	0.64	6.42	1.75	10.6	.6	24.8	44.	53.2	95	78.2
0.125	2.84	0.66	6.52	1.80	10.8	.8	25.1	45.	53.8	96	78.6
0.130	2.89	0.68	6.61	1.90	11.1	10.	25.4	46.	54.4	97	79.0
0.14	3.00	0.70	6.71	2.	11.4	.5	26.0	47.	55.0	98	79.4
0.15	3.11	0.72	6.81	2.1	11.7	11.	26.6	48.	55.6	99	79.8
0.16	3.21	0.74	6.90	2.2	11.9	.5	27.2	49.	56.1	100	80.2
0.17	3.31	0.76	6.99	2.3	12.2	12.	27.8	50.	56.7	125	89.7
0.18	3.40	0.78	7.09	2.4	12.4	.5	28.4	51.	57.3	150	98.3
0.19	3.50	0.80	7.18	2.5	12.6	13.	28.9	52.	57.8	175	106
0.20	3.59	0.82	7.26	2.6	12.0	.5	29.5	53.	58.4	200	114
0.21	3.68	0.84	7.35	2.7	13.2	14.	30.0	54.	59.0	225	120
0.22	3.76	0.86	7.44	2.8	13.4	.5	30.5	55.	59.5	250	126
0.23	3.85	0.88	7.53	2.9	13.7	15.	31.1	56.	60.0	275	133
0.24	3.93	0.90	7.61	3.	13.9	.5	31.6	57.	60.6	300	139
0.25	4.01	0.92	7.69	3.1	14.1	16.	32.1	58.	61.1	350	150
0.26	4.09	0.94	7.78	3.2	14.3	.5	32.6	59.	61.6	400	160
0.27	4.17	0.96	7.86	3.3	14.5	17.	33.1	60.	62.1	450	170
0.28	4.25	0.98	7.94	3.4	14.8	.5	33.6	61.	62.7	500	179
0.29	4.32	1.00	8.02	3.5	15.0	18.	34.0	62.	63.2	550	188
0.30	4.39	1.02	8.10	3.6	15.2	.5	34.5	63.	63.7	600	197
0.31	4.47	1.04	8.18	3.7	15.4	19.	35.0	64.	64.2	700	212
0.32	4.54	1.06	8.26	3.8	15.6	.5	35.4	65.	64.7	800	227
0.33	4.61	1.08	8.34	3.9	15.8	20.	35.9	66.	65.2	900	241
0.34	4.68	1.10	8.41	4.	16.0	.5	36.3	67.	65.7	1000	254
0.35	4.74	1.12	8.49	.2	16.4	21.	36.8	68.	66.1	2000	359
0.36	4.81	1.14	8.57	.4	16.8	.5	37.2	69.	66.6	3000	439
0.37	4.88	1.16	8.64	.6	17.2	22.	37.6	70.	67.1	4000	507
0.38	4.94	1.18	8.72	.8	17.6	.5	38.1	71.	67.6	5000	567

the end of the respective intervals the body will be found at  $C_1, C_2, C_3, C$ , and the mean velocity during each interval is represented by the distances between these points. Such a curved path is traversed by a shot, the impelling force from the gun giving it a uniform velocity in the direction the gun is aimed, and gravity giving it an accelerated velocity downward. *The path of a projectile is a parabola.* The distance it will travel is greatest when its initial direction is at an angle  $45^\circ$  above the horizontal.

**FUNDAMENTAL EQUATIONS IN DYNAMICS.**

**(Uniformly Accelerated Motion)**

Much difficulty to students of Mechanics has resulted from the use in various text-books of such terms as "poundal" as a unit of force (see page 512), "gee-pound," "slug," or "engineers' unit of mass" (= 32.2 lbs. of matter), and by the various definitions given to the words "mass" and "weight." The following elementary treatment of the subject, in which all of these troublesome words are avoided, is taken from an article by the author in *Science*, March 19, 1915. It is urgently commended to the attention of text-book writers and teachers, and constructive criticism of it is solicited.

The fundamental problem is: Given a constant force  $F$  lbs. acting for  $T$  seconds on a quantity of matter  $W$  lbs., at rest at the beginning of the time, but free to move, what are the results, assuming that there is no frictional resistance?

The first result is motion, at a gradually increasing velocity. The relation between the elapsed time and the velocity is determined by experiment. The velocity varies directly as the time and as the force, and inversely as the quantity of matter, and the equation is  $V \propto FT/W$  or  $V = KFT/W$ ,  $K$  being a constant whose value is approximately 32, provided  $V$  is in feet per second,  $F$  and  $W$  in pounds and  $T$  in seconds.

Accurate determinations, involving precise measurements of both  $F$  and  $W$ , and of  $S$ , the distance traversed during the time  $T$ , from which  $V$  is determined, and precautions to eliminate resistance due to friction, give  $K = 32.1740$ . This figure is twice the number of feet that the body would fall *in vacuo* in one second at or near latitude  $45^\circ$  at the sea level. It is commonly represented by  $g$ , or by  $g_0$ , to distinguish it from other values of  $g$  that may be obtained by experiments on falling bodies (or on pendulums) at other latitudes and elevations. The fundamental equation then is

$$V = FTg/W \dots \dots \dots (1)$$

The quantity  $g$  is commonly called the acceleration due to gravity, but it also may be considered either as an abstract figure, the constant  $g$  in equation (1), or as the velocity acquired at the end of 1 second by a falling body, or as the distance a body would travel in 1 second at that same velocity if the force ceased to act and the velocity remained constant.

If the velocity varies directly as the time (uniformly accelerated motion), then the distance is the product of the mean velocity and the time. As the body starts from rest when the velocity is 0, and the velocity is  $V$  at the end of the time  $T$ , the mean velocity is  $1/2 V$  and the distance is  $1/2 VT$ , whence  $V = 2S/T$  and  $T = 2S/V$ .

The velocity  $V$  in feet per second, at the end of the time  $T$  is numerically equal to the number of feet the body would travel in one second after the expiration of the time  $T$  if the force had then ceased to act and the body continued to move at a uniform velocity.

In equation (1) substitute for  $V$  its value  $2S/T$  and we obtain

$$S = \frac{FT^2g}{2W} \dots \dots \dots (2)$$

We have four elementary quantities  $F, T, S, W$ , one derived quantity  $V$ , and one constant figure 32.1740. It is understood that  $F$  is measured in standard pounds of force, one pound of force being the force that gravity exerts on a pound of matter at the standard location where  $g = 32.1740$ .

Each equation contains four variables,  $V, F, T, W$ , or  $S, F, T, W$ , and in either equation if values be given to any three the fourth may be found. By transposition, or by giving new symbols to the product or

quotient of two of the variables, many different equations may be derived from them, the most important of which are given below.

From (1), let  $F = W$ , the case of a body falling at latitude  $45^\circ$  at the sea level; then  $V = gT$ . If  $T$  also = 1, then  $V = g$ , that is the velocity at the end of 1 second is  $g$ .

In the equation  $V = gT$  substitute for  $T$  its value  $2S/V$  and we have  $V = 2gS/V$ , whence  $V^2 = 2gS$ . In the case of falling bodies, the height of fall  $H$  is usually substituted for  $S$ , and we obtain

$$V = \sqrt{2gH} \dots \dots \dots (3)$$

Equation (2) with  $F = W$  gives  $V = 1/2 gT^2$ .

From (1), by transposition we obtain

$$FT = W \times V/g, \text{ or } FT = V \times W/g. \dots \dots \dots (4)$$

The product  $FT$  is sometimes called impulse, and the expression  $W \times V/g$  is called momentum. It is convenient to use the letter  $M$  instead of  $W/g$ , so that the equation becomes

$$FT = MV \dots \dots \dots (5)$$

Impulse = Momentum

In (4) we may substitute for  $T$  its value in terms of  $S$  and  $V$  above given, viz.,  $T = 2S/V$  and obtain  $F2S/V = MV$ ;

$$\text{whence } FS = 1/2 MV^2, \dots \dots \dots (6)$$

Work expended = Kinetic energy.

*Acceleration.* — The quotient  $V/T$  is called the acceleration. It is defined as the rate of increase of velocity. In the problem under consideration, the action of a force on a body free to move, with no retardation by friction, the acceleration is a constant,  $V/T = A$ . Equation (5) then may be written

$$F = MA \dots \dots \dots (7)$$

Force =  $M$  times the acceleration.\*

If a given body is acted on at two different times by two forces  $F$  and  $F_1$ , and if  $A$  and  $A_1$  are the corresponding accelerations, then

$$\frac{F}{F_1} = \frac{MA}{MA_1} \text{ whence } F/F_1 = A/A_1. \dots \dots \dots (8)$$

By the use of these eight equations and their transformations all problems relating to uniformly accelerated motion may be solved.

**Force of Acceleration.** — Force has been defined as that which causes, or tends to cause, or to destroy, motion. It may also be defined as the cause of acceleration; and the unit of force, the pound, as the force required to produce an acceleration of 32.174 ft. per second per second of one pound of matter free to move.

Force equals the product of the mass by the acceleration,\* or  $f = ma$ . Also, if  $v$  = the velocity acquired in the time  $t$ ,  $ft = mv$ ;  $f = mv \div t$ ; the acceleration being uniform.

The force required to produce an acceleration of  $g$  (that is, 32.174 ft. per sec. in one second) is  $f = mg = \frac{w}{g} g = w$ , or the weight of the body.

Also,  $f = ma = m \frac{v_2 - v_1}{t}$ , in which  $v_2$  is the velocity at the end, and  $v_1$  the velocity at the beginning of the time  $t$ , and  $f = mg = \frac{w}{g} \frac{(v_2 - v_1)}{t} =$

$\frac{w}{g} a$ ;  $\frac{f}{w} = \frac{a}{g}$ ; or, the force required to give any acceleration to a body is to the weight of the body as that acceleration is to the acceleration pro-

\* Equation (7) is sometimes read "force equals mass times acceleration," which is strictly true in the dyne-centimeter-gram-second, or "absolute" system of measurements, in which force is measured in dynes, but it is not true in the pound-foot-second system, nor in the metric system where the kilogram is used as a unit of both force and quantity of matter, unless it is understood that the word "mass" means the quotient of  $W$  divided by 32.174.



duced by gravity. In problems in which the local attraction of gravity is a factor the local value of  $g$  must be used if great accuracy is desired.

**EXAMPLE.**—Tension in a cord lifting a weight. A weight of 100 lbs. is lifted vertically by a cord a distance of 80 feet in 4 seconds, the velocity uniformly increasing from 0 to the end of the time. What tension must be maintained in the cord, assuming the local value of  $g$  to be 32.108 or 0.998 of the standard value? Mean velocity =  $v_m = 20$  ft. per sec.;

final velocity =  $v_2 = 2v_m = 40$ ; acceleration  $a = \frac{v_2}{t} = \frac{40}{4} = 10$ . Force

$f = ma = \frac{wa}{g} = \frac{100}{32.174} \times 10 = 31.08$  lbs. The standard value of  $g$ , 32.174 must be used here, for the force required for acceleration is independent of local gravitation. This is the force required to produce the acceleration only; to it must be added the force required to lift the weight without acceleration, or 100 lbs.  $\times 0.998 = 99.8$  lbs., making a total of 130.88 lbs. (The factor 0.998 is used here because the force of gravity at the given locality is 0.002 less than at the standard locality).

The *Resistance to Acceleration* is the same as the force required to produce the acceleration =  $\frac{w}{g} \frac{(v_2 - v_1)}{t}$ .

**Formulae for Accelerated Motion.**—For cases of uniformly accelerated motion other than those of falling bodies, we have the formulae already given,  $f = \frac{w}{g} a, = \frac{w}{g} \frac{v_2 - v_1}{t}$ . If the body starts from rest,  $v_1 = 0, v_2 = v$  and  $f = \frac{w}{g} \frac{v}{t}; fgt = wv$ . We also have  $s = \frac{vt}{2}$ . Transforming

and substituting for  $g$  its value 32.174, we obtain

$$f = \frac{wv^2}{64.35 s} = \frac{wv}{32.17 t} = \frac{ws}{16.09 t^2}; \quad w = \frac{32.17 ft}{v} = \frac{64.35 fs}{v^2};$$

$$s = \frac{wv^2}{64.35 f} = \frac{16.09 ft^2}{w} = \frac{vt}{2}; \quad v = 8.02 \sqrt{\frac{fs}{w}} = \frac{32.17 ft}{w};$$

$$t = \frac{wv}{32.17 f} = \frac{1}{4.01} \sqrt{\frac{ws}{f}}.$$

For any change in velocity,  $f = w \left( \frac{v_2^2 - v_1^2}{64.35 s} \right)$ .

(See also Work of Acceleration, under Work.)

**Motion on Inclined Planes.**—The velocity acquired by a body descending an inclined plane by the force of gravity (friction neglected) is equal to that acquired by a body falling freely from the height of the plane.

The times of descent down different inclined planes of the same height vary as the length of the planes.

The rules for uniformly accelerated motion apply to inclined planes. If  $a$  is the angle of the plane with the horizontal,  $\sin a =$  the ratio of the height to the length =  $\frac{h}{l}$ , and the constant accelerating force is  $g \sin a$ .

The final velocity at the end of  $t$  seconds is  $v = gt \sin a$ . The distance passed over in  $t$  seconds is  $l = \frac{1}{2} gt^2 \sin a$ . The time of descent is

$$t = \sqrt{\frac{2l}{g \sin a}} = \frac{l}{4.01 \sqrt{h}}.$$

**Momentum**, in many books erroneously defined as the quantity of motion in a body, is the product of the mass by the velocity at any instant, =  $mv = \frac{w}{g} v$ . By "mass" is meant the quotient  $w/g$ .

Since  $ft = mv$ , the product of a constant force into the time in which it acts equals numerically the momentum.

Momentum may be defined as numerically equivalent to the number of pounds of force that will stop a moving body in 1 second, or the number of pounds of force which acting during 1 second will give it the given velocity.

**Vis-viva**, or living force, is a term used by early writers on Mechanics to denote the energy stored in a moving body. The term is now obsolete, its place being taken by the word energy.

### WORK, ENERGY, POWER.

The fundamental conceptions in Mechanics are:

**Matter, Force, Time, Space**, represented by  $W, F, T, S$ .

In English units  $W$  and  $F$  are measured in pounds,  $T$  in seconds,  $S$  in feet.

**Velocity** = space divided by time,  $V = S \div T$ , if  $V$  be uniform.  $V$  at end of time  $T$  (uniformly accelerated motion) =  $2S \div T$ .

**Resistance** is that which is opposite to an acting force. It is equal and opposite to force.

**Work** is the overcoming of resistance through a certain distance. It is measured by the product of the resistance into the space through which it is overcome. It is also measured by the product of the moving force into the distance through which the force acts in overcoming the resistance. Thus in lifting a body from the earth against the attraction of gravity, the resistance is the weight of the body, and the product of this weight into the height the body is lifted is the work done.

**The Unit of Work**, in British measures, is the *foot-pound*, or the amount of work done in overcoming a pressure or weight equal to one pound through one foot of space.

The work performed by a piston in driving a fluid before it, or by a fluid in driving a piston before it, may be expressed in either of the following ways:

$$\begin{aligned} & \text{Resistance} \times \text{distance traversed} \\ & = \text{intensity of pressure} \times \text{area} \times \text{distance traversed}; \\ & = \text{intensity of pressure} \times \text{volume traversed}. \end{aligned}$$

By intensity of pressure is meant pressure per unit of area, as lbs. per sq. in.

The work performed in lifting a body is the product of the weight of the body into the height through which its center of gravity is lifted.

If a machine lifts the centers of gravity of several bodies at once to heights either the same or different, the whole quantity of work performed in so doing is the sum of the several products of the weights and heights; but that quantity can also be computed by multiplying the sum of all the weights into the height through which their common center of gravity is lifted. (Rankine.)

**Power** is the rate at which work is done, and is expressed by the quotient of the work divided by the time in which it is done, or by units of work per second, per minute, etc., as foot-pounds per second. The most common unit of power is the *horse-power*, established by James Watt as the power of a strong London draught-horse to do work during a short interval, and used by him to measure the power of his steam-engines. This unit is 33,000 foot-pounds per minute = 550 foot-pounds per second = 1,980,000 foot-pounds per hour.

Power exerted for a certain time produces work;  $PT = FS = FVT$ , if  $V$  be uniform.

**Horse-power Hours**, an expression for work measured as the product of a power into the time during which it acts, =  $PT$ . Sometimes it is the summation of a variable power for a given time, or the average power multiplied by the time.

**Energy**, or stored work, is the capacity for performing work. It is measured by the same unit as work, that is, in foot-pounds. It may be either *potential*, as in the case of a body of water stored in a reservoir, capable of doing work by means of a water-wheel, or *actual*, sometimes called *kinetic*, which is the energy of a moving body. Potential energy is measured by the product of the weight of the stored body into the distance through which it is capable of acting, or by the product of the pressure it exerts into the distance through which that pressure is capable of acting. Potential energy may also exist as stored heat, or as stored chemical energy, as in fuel, gunpowder, etc., or as electrical energy, the measure of these energies being the amount of work that they are capable of performing. Actual energy of a moving body is the work which it is capable of performing against a retarding resistance before being brought to rest, and is equal to the work which must be done upon it to bring it from a state of rest to its actual velocity.

The measure of actual energy is the product of the weight of the body into the height from which it must fall to acquire its actual velocity. If  $v$  = the velocity in feet per second, according to the principle of falling bodies,  $h$ , the height due to the velocity, =  $\frac{v^2}{2g}$ ; and if  $w$  = the weight, the energy =  $1/2 mv^2 = wv^2 \div 2g = wh$ . Since energy is the capacity for performing work, the units of work and energy are equivalent, or  $FS = 1/2 mv^2 = wh$ . Energy exerted = work done.

The actual energy of a rotating body whose angular velocity is  $A$  and moment of inertia  $\Sigma wr^2 = I$  is  $\frac{A^2 I}{2g}$ , that is, the product of the moment of inertia into the height due to the velocity,  $A$ , of a point whose distance from the axis of rotation is unity; or it is equal to  $\frac{wv^2}{2g}$ , in which  $w$  is the weight of the body and  $v$  is the velocity of the center of gyration.

**Work of Acceleration.**—The work done in giving acceleration to a body is equal to the product of the force producing the acceleration, or of the resistance to acceleration, into the distance moved in a given time. This force, as already stated, equals product of the mass into the acceleration, or  $f = ma = \frac{w}{g} \frac{v_2 - v_1}{t}$ . If the distance traversed in the time  $t = s$ , then work =  $fs = \frac{w}{g} \frac{v_2 - v_1}{t} s$ .

**EXAMPLE.**—What work is required to move a body weighing 100 lbs. horizontally a distance of 80 ft. in 4 seconds, the velocity uniformly increasing, friction neglected?

Mean velocity  $v_m = 20$  ft. per second; final velocity =  $v_2 = 2 v_m = 40$ ; initial velocity  $v_1 = 0$ ; acceleration,  $a = \frac{v_2 - v_1}{t} = \frac{40}{4} = 10$ ; force =  $\frac{w}{g} a = \frac{100}{32.17} \times 10 = 31.1$  lbs.; distance 80 ft.; work =  $fs = 31.1 \times 80 = 2488$  foot-pounds.

The energy stored in the body moving at the final velocity of 40 ft. per second is

$$1/2 mv^2 = \frac{1}{2} \frac{w}{g} v^2 = \frac{100 \times 40^2}{2 \times 32.17} = 2488 \text{ foot-pounds,}$$

which equals the work of acceleration,

$$fs = \frac{w}{g} \frac{v_2}{t} s = \frac{w}{g} \frac{v_2}{t} \frac{v_2}{2} t = \frac{1}{2} \frac{w}{g} v_2^2.$$

If a body of the weight  $W$  falls from a height  $H$ , the work of acceleration is simply  $WH$ , or the same as the work required to raise the body to the same height.

**Work of Accelerated Rotation.**—Let  $A$  = angular velocity of a solid body rotating about an axis, that is, the velocity of a particle whose radius is unity. Then the velocity of a particle whose radius is  $r$  is  $v = Ar$ . If the angular velocity is accelerated from  $A_1$  to  $A_2$ , the increase of the velocity of the particle is  $v_2 - v_1 = r(A_2 - A_1)$ , and the work of accelerating it is

$$\frac{w}{g} \times \frac{v_2^2 - v_1^2}{2} = \frac{wr^2}{g} \frac{A_2^2 - A_1^2}{2},$$

in which  $w$  is the weight of the particle.  $A$  is measured in radians.

The work of acceleration of the whole body is

$$\Sigma \left\{ \frac{w}{g} \times \frac{v_2^2 - v_1^2}{2} \right\} = \frac{A_2^2 - A_1^2}{2g} \times \Sigma wr^2.$$

The term  $\Sigma wr^2$  is the moment of inertia of the body.

**“Force of the Blow” of a Steam Hammer or Other Falling Weight.**—The question is often asked: “With what force does a falling hammer strike?” The question cannot be answered directly, and it is based upon a misconception or ignorance of fundamental mechanical



**laws.** The energy, or capacity for doing work, of a body raised to a given height and let fall cannot be expressed in pounds, simply, but only in foot-pounds, which is the product of the weight into the height through which it falls, or the product of its weight  $\div 64.32$  into the square of the velocity, in feet per second, which it acquires after falling through the given height. If  $F$  = weight of the body,  $M$  its mass,  $g$  the acceleration due to gravity,  $S$  the height of fall, and  $v$  the velocity at the end of the fall, the energy in the body just before striking is  $FS = \frac{1}{2} Mv^2 = Wv^2 \div 2g = Wv^2 \div 64.32$ , which is the general equation of energy of a moving body. Just as the energy of the body is a product of a force into a distance, so the work it does when it strikes is not the manifestation of a force, which can be expressed simply in pounds, but it is the overcoming of a resistance through a certain distance, which is expressed as the product of the average resistance into the distance through which it is exerted. If a hammer weighing 100 lbs. falls 10 ft., its energy is 1000 foot-pounds. Before being brought to rest it must do 1000 foot-pounds of work against one or more resistances. These are of various kinds, such as that due to motion imparted to the body struck, penetration against friction, or against resistance to shearing or other deformation, and crushing and heating of both the falling body and the body struck. The distance through which these resisting forces act is generally indeterminate, and therefore the average of the resisting forces, which themselves generally vary with the distance, is also indeterminate.

**Impact of Bodies.** — If two inelastic bodies collide, they will move on together as one mass, with a common velocity. The momentum of the combined mass is equal to the sum of the momenta of the two bodies before impact. If  $m_1$  and  $m_2$  are the masses of the two bodies and  $v_1$  and  $v_2$  their respective velocities before impact, and  $v$  their common velocity after impact,  $(m_1 + m_2)v = m_1v_1 + m_2v_2$ ,

$$v = \frac{m_1v_1 + m_2v_2}{m_1 + m_2}.$$

If the bodies move in opposite directions,  $v = \frac{m_1v_1 - m_2v_2}{m_1 + m_2}$ , or the velocity of two inelastic bodies after impact is equal to the algebraic sum of their momenta before impact, divided by the sum of their masses.

If two inelastic bodies of equal momenta impinge directly upon one another from opposite directions they will be brought to rest.

**Impact of Inelastic Bodies Causes a Loss of Energy,** and this loss is equal to the sum of the energies due to the velocities lost and gained by the bodies, respectively.

$\frac{1}{2} m_1v_1^2 + \frac{1}{2} m_2v_2^2 - \frac{1}{2} (m_1 + m_2)v^2 = \frac{1}{2} m_1(v_1 - v)^2 + \frac{1}{2} m_2(v_2 - v)^2$ ; in which  $v_1 - v$  is the velocity lost by  $m_1$  and  $v - v_2$  the velocity gained by  $m_2$ .

**EXAMPLE.** — Let  $m_1 = 10$ ,  $m_2 = 8$ ,  $v_1 = 12$ ,  $v_2 = 15$ .

If the bodies collide they will come to rest, for  $v = \frac{10 \times 12 - 8 \times 15}{10 + 8} = 0$ .

The energy loss is

$$\frac{1}{2} 10 \times 144 + \frac{1}{2} 8 \times 225 - \frac{1}{2} 18 \times 0 = \frac{1}{2} 10 (12 - 0)^2 + \frac{1}{2} 8 (15 - 0)^2 = 1620 \text{ ft.-lbs.}$$

What becomes of the energy lost? **Ans.** It is used doing internal work on the bodies themselves, changing their shape and heating them.

For *imperfectly elastic bodies*, let  $e$  = the elasticity, that is, the ratio which the force of restitution, or the internal force tending to restore the shape of a body after it has been compressed, bears to the force of compression; and let  $m_1$  and  $m_2$  be the masses,  $v_1$  and  $v_2$  their velocities before impact, and  $v_1'$ ,  $v_2'$  their velocities after impact; then

$$v_1' = \frac{m_1v_1 + m_2v_2}{m_1 + m_2} - \frac{m_2e(v_1 - v_2)}{m_1 + m_2};$$

$$v_2' = \frac{m_1v_1 + m_2v_2}{m_1 + m_2} + \frac{m_1e(v_1 - v_2)}{m_1 + m_2}.$$

If the bodies are perfectly elastic, their relative velocities before and after impact are the same. That is,  $v_1' - v_2' = v_2 - v_1$ .

In the impact of bodies, the sum of their momenta after impact is the same as the sum of their momenta before impact.

$$m_1v_1' + m_2v_2' = m_1v_1 + m_2v_2.$$

For demonstration of these and other laws of impact, see Smith's Mechanics; also, Weisbach's Mechanics.

**Energy of Recoil of Guns.** (*Eng'g*, Jan. 25, 1884, p. 72.) —

Let  $W$  = the weight of the gun and carriage;  
 $V$  = the maximum velocity of recoil;  
 $w$  = the weight of the projectile;  
 $v$  = the muzzle velocity of the projectile.

Then, since the momentum of the gun and carriage is equal to the momentum of the projectile (because both are acted on by equal force, the pressure of the gases in the gun, for equal time), we have  $WV = wv$ , or  $V = wv \div W$ .

Taking the case of a 10-inch gun firing a 400-lb. projectile with a muzzle velocity of 2000 feet per second, the weight of the gun and carriage being 22 tons = 50,000 lbs., we find the velocity of recoil =

$$V = \frac{2000 \times 400}{50,000} = 16 \text{ feet per second.}$$

Now the energy of a body in motion is  $WV^2 \div 2g$ .

Therefore the energy of recoil =  $\frac{50,000 \times 16^2}{2 \times 32.2} = 198,800$  foot-pounds.

The energy of the projectile is  $\frac{400 \times 2000^2}{2 \times 32.2} = 24,844,000$  foot-pounds.

**Conservation of Energy.** — No form of energy can ever be produced except by the expenditure of some other form, nor annihilated except by being reproduced in another form. Consequently the sum total of energy in the universe, like the sum total of matter, must always remain the same. (S. Newcomb.) Energy can never be destroyed or lost; it can be transformed, can be transferred from one body to another, but no matter what transformations are undergone, when the total effects of the exertion of a given amount of energy are summed up the result will be exactly equal to the amount originally expended from the source. This law is called the Conservation of Energy. (Cotterill and Slade.)

A heavy body sustained at an elevated position has potential energy. When it falls, just before it reaches the earth's surface it has actual or kinetic energy, due to its velocity. When it strikes, it may penetrate the earth a certain distance or may be crushed. In either case friction results by which the energy is converted into heat, which is gradually radiated into the earth or into the atmosphere, or both. Mechanical energy and heat are mutually convertible. Electric energy is also convertible into heat or mechanical energy, and either kind of energy may be converted into the other.

**Sources of Energy.** — The principal sources of energy on the earth's surface are the muscular energy of men and animals, the energy of the wind, of flowing water, and of fuel. These sources derive their energy from the rays of the sun. Under the influence of the sun's rays vegetation grows and wood is formed. The wood may be used as fuel under a steam-boiler, its carbon being burned to carbon dioxide. Three-tenths of its heat energy escapes in the chimney and by radiation, and seven-tenths appears as potential energy in the steam. In the steam-engine, of this seven-tenths six parts are dissipated in heating the condensing water and are wasted; the remaining one-tenth of the original heat energy of the wood is converted into mechanical work in the steam-engine, which may be used to drive machinery. This work is finally, by friction of various kinds, or possibly after transformation into electric currents, transformed into heat which is radiated into the atmosphere, increasing its temperature. Thus

all the potential heat energy of the wood is, after various transformations, converted into heat, which, mingling with the store of heat in the atmosphere, apparently is lost. But the carbon dioxide generated by the combustion of the wood is, again, under the influence of the sun's rays, absorbed by vegetation, and more wood may thus be formed having potential energy equal to the original.

**Perpetual Motion.** — The law of the conservation of energy, than which no law of mechanics is more firmly established, is an absolute barrier to all schemes for obtaining by mechanical means what is called "perpetual motion," or a machine which will do an amount of work greater than the equivalent of the energy, whether of heat, of chemical combination, of electricity, or mechanical energy, that is put into it. Such a result would be the creation of an additional store of energy in the universe, which is not possible by any human agency.

**The Efficiency of a Machine** is a fraction expressing the ratio of the useful work to the whole work performed, which is equal to the energy expended. The limit to the efficiency of a machine is unity, denoting the efficiency of a perfect machine in which no work is lost. The difference between the energy expended and the useful work done, or the loss, is usually expended either in overcoming friction or in doing work on bodies surrounding the machine from which no useful work is received. Thus in an engine propelling a vessel part of the energy exerted in the cylinder does the useful work of giving motion to the vessel, and the remainder is spent in overcoming the friction of the machinery and in making currents and eddies in the surrounding water.

A common and useful definition of efficiency is "output divided by input."

### ANIMAL POWER.

#### Work of a Man against Known Resistances. (Rankine.)

Kind of Exertion.	$R$ , lbs.	$V$ , ft. per sec.	$\frac{T''}{3600}$ (hours per day).	$RV$ , ft.-lbs. per sec.	$RVT$ , ft.-lbs. per day.
1. Raising his own weight up stair or ladder.....	143	0.5	8	71.5	2,059,200
2. Hauling up weights with rope, and lowering the rope unloaded.....	40	0.75	6	30	648,000
3. Lifting weights by hand.....	44	0.55	6	24.2	522,720
4. Carrying weights up-stairs and returning unloaded....	143	0.13	6	18.5	399,600
5. Shoveling up earth to a height of 5 ft. 3 in.....	6	1.3	10	7.8	280,800
6. Wheeling earth in barrow up slope of 1 in 12, $\frac{1}{2}$ horiz. veloc. 0.9 ft. per sec., and returning unloaded.....	132	0.075	10	9.9	356,400
7. Pushing or pulling horizontally (capstan or oar).....	26.5	2.0	8	53	1,526,400
8. Turning a crank or winch....	12.5	5.0	?	62.5	.....
	18.0	2.5	8	45	1,296,000
	20.0	14.4	2 min.	288	.....
9. Working pump.....	13.2	2.5	10	33	1,188,000
10. Hammering.....	15	?	8?	?	480,000

**EXPLANATION.** —  $R$ , resistance;  $V$ , effective velocity = distance through which  $R$  is overcome ÷ total time occupied, including the time of moving unloaded, if any;  $T''$ , time of working, in seconds per day;  $T'' \div 3600$ , same time, in hours per day;  $RV$ , effective power, in foot-pounds per second;  $RVT$ , daily work.



**Performance of a Man in Transporting Loads Horizontally.**  
(Rankine.)

Kind of Exertion.	<i>L</i> , lbs.	<i>V</i> , ft.-sec.	$\frac{T''}{3600}$ (hours per day).	<i>LV</i> , lbs. con- veyed 1 foot.	<i>LVT</i> , lbs. con- veyed 1 foot.
11. Walking unloaded, transporting his own weight . . .	140	5	10	700	25,200,000
12. Wheeling load <i>L</i> in 2-whld. barrow, return unloaded . .	224	12/3	10	373	13,428,000
13. Ditto in 1-wh. barrow, ditto . .	132	12/3	10	220	7,920,000
14. Traveling with burden . . . . .	90	21/2	7	225	5,670,000
15. Carrying burden, returning unloaded . . . . .	140	12/3	6	233	5,032,800
16. Carrying burden, for 30 seconds only . . . . .	252	0	.....	0	.....
	126	11.7	.....	1474.2	.....
	0	23.1	.....	0	.....

EXPLANATION. — *L*, load; *V*, effective velocity, computed as before; *T''*, time of working, in seconds per day;  $T'' \div 3600$ , same time in hours per day; *LV*, transport per second, in lbs. conveyed one foot; *LVT*, daily transport.

In the first line only of each of the two tables above is the weight of the man taken into account in computing the work done.

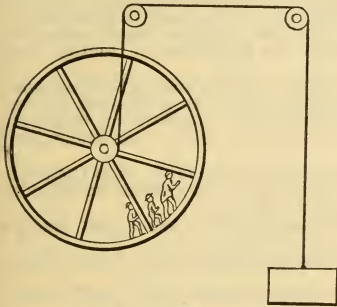

FIG. 108.

Clark says that the average net daily work of an ordinary laborer at a pump, a winch, or a crane may be taken at 3300 foot-pounds per minute, or one-tenth of a horsepower, for 8 hours a day; but for shorter periods from four to five times this rate may be exerted.

Mr. Glynn says that a man may exert a force of 25 lbs. at the handle of a crane for short periods; but that for continuous work a force of 15 lbs. is all that should be assumed, moving through 220 feet per minute.

**Man-wheel.**—Fig. 108 is a sketch of a very efficient man-power hoisting-machine which the author saw in Berne, Switzerland, in 1889.

The face of the wheel was wide enough for three men to walk abreast, so that nine men could work in it at one time.

**Work of a Horse against a Known Resistance.** (Rankine.)

Kind of Exertion.	<i>R</i> .	<i>V</i> .	$\frac{T''}{3600}$	<i>RV</i> .	<i>RVT</i> .					
1. Cantering and trotting, drawing a light railway carriage (thoroughbred) . . . . .	$\left\{ \begin{array}{l} \text{min. } 22\frac{1}{2} \\ \text{mean } 30\frac{1}{2} \\ \text{max. } 50 \end{array} \right\}$	142/3	4	4471/2	6,444,000					
2. Horse drawing cart or boat, walking (draught-horse) . . .						120	3.6	8	432	12,441,600
3. Horse drawing a gin or mill, walking . . . . .						100	3.0	8	300	8,640,000
4. Ditto, trotting . . . . .	66	6.5	41/2	429	6,950,000					

EXPLANATION. —  $R$ , resistance, in lbs.;  $V$ , velocity, in feet per second;  $T'' \div 3600$ , hours work per day;  $RV$ , work per second;  $RVT$ , work per day.

The average power of a draught-horse, as given in line 2 of the above table, being 432 foot-pounds per second, is  $\frac{432}{550} = 0.785$  of the conventional value assigned by Watt to the ordinary unit of the rate of work of prime movers. It is the mean of several results of experiments, and may be considered the average of ordinary performance under favorable circumstances.

**Performance of a Horse in Transporting Loads Horizontally.**  
(Rankine.)

Kind of Exertion.	$L$ .	$V$ .	$T$ .	$LV$ .	$LVT$ .
5. Walking with cart, always loaded.....	1500	3.6	10	5400	194,400,000
6. Trotting, ditto.....	750	7.2	41/2	5400	87,480,000
7. Walking with cart, going loaded, returning empty; $V$ , mean velocity.....	1500	2.0	10	3000	108,000,000
8. Carrying burden, walking..	270	3.6	10	972	34,992,000
9. Ditto, trotting.....	180	7.2	7	1296	32,659,200

EXPLANATION. —  $L$ , load in lbs.;  $V$ , velocity in feet per second;  $T$ , working hours per day;  $LV$ , transport per second;  $LVT$ , transport per day.

This table has reference to conveyance on common roads only, and those evidently in bad order as respects the resistance to traction upon them.

**Horse-Gin.** — In this machine a horse works less advantageously than in drawing a carriage along a straight track. In order that the best possible results may be realized with a horse-gin, the diameter of the circular track in which the horse walks should not be less than about forty feet.

**Oxen, Mules, Asses.** — Authorities differ considerably as to the power of these animals. The following may be taken as an approximative comparison between them and draught-horses (Rankine):

*Ox.* — Load, the same as that of average draught-horse; best velocity and work, two-thirds of horse.

*Mule.* — Load, one-half of that of average draught-horse; best velocity, the same as horse; work, one-half.

*Ass.* — Load, one-quarter that of average draught-horse; best velocity, the same; work, one-quarter.

**Reduction of Draught of Horses by Increase of Grade of Roads.** (*Engineering Record*, Prize Essays on Roads, 1892.) — Experiments on English roads by Gayffier & Parnell:

Calling load that can be drawn on a level 100:

On a rise of..... 1 in 100. 1 in 50. 1 in 40. 1 in 30. 1 in 26. 1 in 20. 1 in 10.  
A horse can draw only 90 81 72 64 54 40 25

**The Resistance of Carriages on Roads** is (according to Gen. Morin) given approximately by the following empirical formula:

$$R = \frac{W}{r} [a + b(u - 3.28)].$$

In this formula  $R$  = total resistance;  $r$  = radius of wheel in inches;  $W$  = gross load;  $u$  = velocity in feet per second; while  $a$  and  $b$  are constants, whose values are: For good broken-stone road,  $a = 0.4$  to  $0.55$ ,  $b = 0.024$  to  $0.026$ ; for paved roads,  $a = 0.27$ ,  $b = 0.0684$ .

Rankine states that on gravel the resistance is about double, and on sand five times, the resistance on good broken-stone roads.

## ELEMENTS OF MACHINES.

The object of a machine is usually to transform the work or mechanical energy exerted at the point where the machine receives its motion into work at the point where the final resistance is overcome. The specific result may be to change the character or direction of motion, as from circular to rectilinear, or *vice versa*, to change the velocity, or to overcome a great resistance by the application of a moderate force. In all cases the total energy exerted equals the total work done, the latter including the overcoming of all the frictional resistances of the machine as well as the useful work performed. No increase of power can be obtained from any machine, since this is impossible according to the law of conservation of energy. In a frictionless machine the product of the force exerted at the driving-point, or the distance it moves in a given interval of time, equals the product of the resistance into the distance through which the resistance is overcome in the same time.

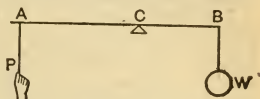

FIG. 109.

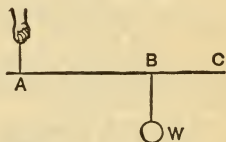

FIG. 110.

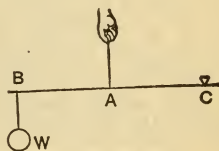

FIG. 111.

The most simple machines, or elementary machines, are reducible to three classes, viz., the Lever, the Cord, and the Inclined Plane.

The first class includes every machine consisting of a solid body capable of revolving on an axis, as the Wheel and Axle.

The second class includes every machine in which force is transmitted by means of flexible threads, ropes, etc., as the Pulley.

The third class includes every machine in which a hard surface inclined to the direction of motion is introduced, as the Wedge and the Screw.

A **Lever** is an inflexible rod capable of motion about a fixed point, called a fulcrum. The rod may be straight or bent at any angle, or curved.

It is generally regarded, at first, as without weight, but its weight may be considered as another force applied in a vertical direction at its center of gravity.

The arms of a lever are the portions of it intercepted between the force,  $P$ , and fulcrum,  $C$ , and between the weight or load,  $W$ , and fulcrum.

Lever arms are divided into three kinds or orders, according to the relative positions of the applied force, load, and fulcrum.

In a lever of the first order, the fulcrum lies between the points at which the force and load act. (Fig. 109.)

In a lever of the second order, the load acts at a point between the fulcrum and the point of action of the force. (Fig. 110.)

In a lever of the third order, the point of action of the force is between that of the load and the fulcrum. (Fig. 111.)

In all cases of levers the relation between the force exerted or the pull,  $P$ , and the load lifted, or resistance overcome,  $W$ , is expressed by the equation  $P \times AC = W \times BC$ , in which  $AC$  is the lever-arm of  $P$ , and  $BC$  is the lever-arm of  $W$ , or moment of the force = the moment of the resistance. (See Moment.)

In cases in which the direction of the force (or of the resistance) is not at right angles to the arm of the lever on which it acts, the "lever-arm" is the length of a perpendicular from the fulcrum to the line of direction of the force (or of the resistance).  $W : P :: AC : BC$ , or, the ratio of the resistance to the applied force is the inverse ratio of their lever-arms. Also, if  $Vw$  is the velocity of  $W$ , and  $Vp$  is the velocity of  $P$ ,  $W : P :: Vp : Vw$ , and  $P \times Vp = W \times Vw$ .

If  $Sp$  is the distance through which the applied force acts, and  $Sw$  is the distance the load is lifted or through which the resistance is overcome,  $W : P :: Sp : Sw$ , or  $W \times Sw = P \times Sp$ , or the load into the dis-



tance it is lifted equals the force into the distance through which it is exerted.

These equations are general for all classes of machines as well as for levers, it being understood that friction, which in actual machines increases the resistance, is not at present considered.

**The Bent Lever.** — In the bent lever (see Fig. 102, p. 514), the lever-arm of the weight  $m$  is  $cf$  instead of  $bf$ . The lever is in equilibrium when  $n \times af = m \times cf$ , but it is to be observed that the action of a bent lever may be very different from that of a straight lever. In the latter, so long as the force and the resistance act in lines parallel to each other, the ratio of the lever-arms remains constant, although the lever itself changes its inclination with the horizontal. In the bent lever, however, this ratio changes: thus, in the cut, if the arm  $bf$  is depressed to a horizontal direction, the distance  $cf$  lengthens while the horizontal projection of  $af$  shortens, the latter becoming zero when the direction of  $af$  becomes vertical. As the arm  $af$  approaches the vertical, the weight  $n$  which may be lifted with a given force  $s$  is very great, but the distance through which it may be lifted is very small. In all cases the ratio of the weight  $m$  to the weight  $n$  is the inverse ratio of the horizontal projection of their respective lever-arms.

**The Moving Strut (Fig. 112)** is similar to the bent lever, except that one of the arms is missing, and that the force and the resistance to be overcome act at the same end of the single arm. The resistance in the case shown in the cut is not the load  $W$ , but its resistance to being moved,  $R$ , which may be simply that due to its friction on the horizontal plane, or some other opposing force. When the angle between the strut and the horizontal plane changes, the ratio of the resistance to the applied force changes. When the angle becomes very small, a moderate force will overcome a very great resistance, which tends to become infinite as the angle approaches zero. If  $a$  = the angle,  $P \times \cos a = R \times \sin a$ . If  $a = 5$  degrees,  $\cos a = 0.99619$ ,  $\sin a = 0.08716$ ,  $R = 11.44 P$ .

The stone-crusher (Fig. 113) shows a practical example of the use of two moving struts.

**The Toggle-joint** is an elbow or knee-joint consisting of two bars so connected that they may be brought into a straight line and made to produce great endwise pressure when a force is applied to bring them into this position. It is a case of two moving struts placed end to end,

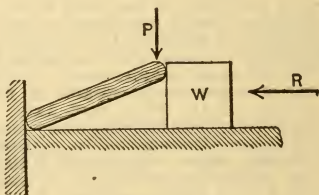

FIG. 112.

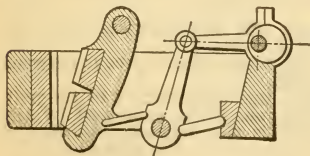

FIG. 113.

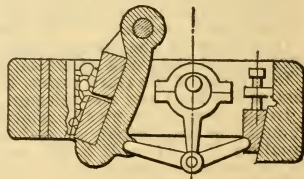

FIG. 114.

the moving force being applied at their point of junction, in a direction at right angles to the direction of the resistance, the other end of one of the struts resting against a fixed abutment, and that of the other against the body to be moved. If  $a$  = the angle each strut makes with the straight line joining the points about which their outer ends rotate, the ratio of the resistance to the applied force is  $R : P :: \cos a : 2 \sin a$ ;  $2 R \sin a = P \cos a$ . The ratio varies when the angle varies, becoming infinite when the angle becomes zero.

The toggle-joint is used where great resistances are to be overcome through very small distances, as in stone-crushers (Fig. 114).

**The Inclined Plane**, as a mechanical element, is supposed perfectly hard and smooth, unless friction be considered. It assists in sustaining a heavy body by its reaction. This reaction, however, being normal to the plane, cannot entirely counteract the weight of the body, which acts vertically downward. Some other force must therefore be made to act upon the body, in order that it may be sustained.

If the sustaining force act parallel to the plane (Fig. 115), the force is to the weight as the height of the plane is to its length, measured on the incline.

If the force act parallel to the base of the plane, the force is to the weight as the height is to the base.

If the force act at any other angle, let  $i$  = the angle of the plane with the horizon, and  $e$  = the angle of the direction of the applied force with the angle of the plane.

$$P : W :: \sin i : \cos e; P \times \cos e = W \sin i.$$

Problems of the inclined plane may be solved by the parallelogram of forces thus:

Let the weight  $W$  be kept at rest on the incline by the force  $P$ , acting in the line  $bP'$ , parallel to the plane. Draw the vertical line  $ba$  to represent the weight; also  $bb'$  perpendicular to the plane, and complete the parallelogram  $b'c$ . Then the vertical weight  $ba$  is the resultant of  $bb'$ , the measure of support given by the plane to the weight, and  $bc$ , the force of gravity tending to draw the weight down the plane. The force required to maintain the weight in equilibrium is represented by this force  $bc$ . Thus the force and the weight are in the ratio of  $bc$  to  $ba$ . Since the triangle of forces  $abc$  is similar to the triangle of the incline  $ABC$ , the latter may be substituted for the former in determining the relative magnitude of the forces, and

$$P : W :: bc : ab :: BC : AB.$$

**The Wedge** is a pair of inclined planes united by their bases. In the application of pressure to the head or butt end of the wedge, to cause it to penetrate a resisting body, the applied force is to the resistance as the thickness of the wedge is to its length. Let  $t$  be the thickness,  $l$  the length,  $W$  the resistance, and  $P$  the applied force or pressure on the head of the wedge. Then, friction neglected,  $P : W :: t : l$ ;  $P = \frac{Wt}{l}$ ;  $W = \frac{Pl}{t}$ .

**The Screw** is an inclined plane wrapped around a cylinder in such a way that the height of the plane is parallel to the axis of the cylinder. If the screw is formed upon the internal surface of a hollow cylinder, it is usually called a nut. When force is applied to raise a weight or overcome a resistance by means of a screw and nut, either the screw or the nut may be fixed, the other being movable. The force is generally applied at the end of a wrench or lever-arm, or at the circumference of a wheel. If  $r$  = radius of the wheel or lever-arm, and  $p$  = pitch of the screw, or distance between threads, that is, the height of the inclined plane for one revolution of the screw,  $P$  = the applied force, and  $W$  = the resistance overcome, then, neglecting resistance due to friction,  $2\pi r \times P = Wp$ ;  $W = 6.283 Pr \div p$ . The ratio of  $P$  to  $W$  is thus independent of the diameter of the screw. In actual screws, much of the power transmitted is lost through friction.

**The Cam** is a revolving inclined plane. It may be either an inclined plane wrapped around a cylinder in such a way that the height of the plane is radial to the cylinder, such as the ordinary lifting-cam, used in stamp-mills (Fig. 116),



FIG. 116.

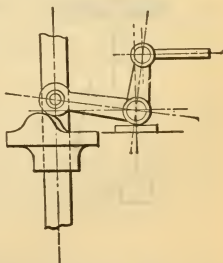

FIG. 117.

or it may be an inclined plane curved edgewise, and rotating in a plane parallel to its base (Fig. 117). The relation of the weight to the applied force is calculated in the same manner as in the case of the screw.

**Efficiency of a Screw.**—Let  $a$  = angle of the thread, that is, the angle whose tangent is the pitch of the screw divided by the circumference of a circle whose diameter is the mean of the diameters at the top and bottom of the thread. Then for a square thread

$$\text{Efficiency} = (1 - f \tan a) \div (1 + f \cotan a),$$

in which  $f$  is the coefficient of friction. (For demonstration, see Cotterill and Slade, Applied Mechanics.) Since  $\cotan = 1 \div \tan$ , we may substitute for  $\cotan a$  the reciprocal of the tangent, or if  $p$  = pitch, and  $c$  = mean circumference of the screw,

$$\text{Efficiency} = (1 - fp/c) \div (1 + fc/p).$$

**EXAMPLE.**—Efficiency of square-threaded screws of  $1/2$  inch pitch.

Diameter at bottom of thread, in. . . . .	1	2	3	4
Diameter at top of thread, in. . . . .	$1\frac{1}{2}$	$2\frac{1}{2}$	$3\frac{1}{2}$	$4\frac{1}{2}$
Mean circumference of thread, in. . . . .	3.927	7.069	10.21	13.35
Cotangent $a = c \div p$ . . . . .	=7.854	14.14	20.42	26.70
Tangent $a = p \div c$ . . . . .	=0.1273	.0707	.0490	.0375
Efficiency if $f = 0.10$ . . . . .	=55.3%	41.2%	32.7%	27.2%
Efficiency if $f = 0.15$ . . . . .	=45%	31.7%	24.4%	19.9%

The efficiency thus increases with the steepness of the pitch.

The above formulæ and examples are for square-threaded screws, and consider the friction of the screw-thread only, and not the friction of the collar or step by which end thrust is resisted, and which further reduces the efficiency. The efficiency is also further reduced by giving an inclination to the side of the thread, as in the V-threaded screw. For discussion of this subject, see paper by Wilfred Lewis, Jour. Frank. Inst. 1880; also *Trans. A. S. M. E.*, vol. xii, 784.

**Efficiency of Screw-bolts.**—Mr. Lewis gives the following approximate formula for ordinary screw-bolts (V-threads, with collars):  $p$  = pitch of screw,  $d$  = outside diameter of screw,  $F$  = force applied at circumference to lift a unit of weight,  $E$  = efficiency of screw. For an average case, in which the coefficient of friction may be assumed at 0.15,

$$F = (p + d) \div 3d, \quad E = p \div (p + d).$$

For bolts of the dimensions given above,  $1/2$ -inch pitch, and outside diameters  $1\frac{1}{2}$ ,  $2\frac{1}{2}$ ,  $3\frac{1}{2}$ , and  $4\frac{1}{2}$  inches, the efficiencies according to this formula would be, respectively, 0.25, 0.167, 0.125, and 0.10.

James McBride (*Trans. A. S. M. E.*, xii, 781) describes an experiment with an ordinary 2-inch screw-bolt, with a V-thread,  $4\frac{1}{2}$  threads per inch, raising a weight of 7500 pounds, the force being applied by turning the nut. Of the power applied 89.8 per cent was absorbed by friction of the nut on its supporting washer and of the threads of the bolt in the nut. The nut was not faced, and had the flat side to the washer.

Professor Ball in his "Experimental Mechanics" says: "Experiments showed in two cases respectively about  $2/3$  and  $3/4$  of the power was lost." Weisbach says: "The efficiency is from 19 per cent to 30 per cent."

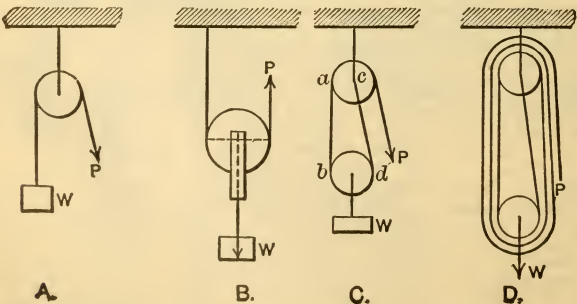

FIG. 118,



**Pulleys or Blocks.** —  $P$  = force applied, or pull;  $W$  = load lifted, or resistance. In the simple pulley  $A$  (Fig. 118) the point  $P$  on the pulling rope descends the same amount that the load is lifted, therefore  $P=W$ . In  $B$  and  $C$  the point  $P$  moves twice as far as the load is lifted, therefore  $W=2P$ . In  $B$  and  $C$  there is one movable block, and two plies of the rope engage with it. In  $D$  there are three sheaves in the movable block, each with two plies engaged, or six in all. Six plies of the rope are therefore shortened by the same amount that the load is lifted and the point  $P$  moves six times as far as the load, consequently  $W=6P$ . In general, the ratio of  $W$  to  $P$  is equal to the number of plies of the rope that are shortened, and also is equal to the number of plies that engage the lower block. If the lower block has 2 sheaves and the upper 3, the end of the rope is fastened to a hook in the top of the lower block, and then there are 5 plies shortened instead of 6, and  $W=5P$ . If  $V$  = velocity of  $W$ , and  $v$  = velocity of  $P$ , then in all cases  $VW = vP$ , whatever the number of sheaves or their arrangement. If the hauling rope, at the pulling end, passes first around a sheave in the upper or stationary block, it makes no difference in what direction the rope is led from this block to the point at which the pull on the rope is applied; but if it first passes around the movable block, it is necessary that the pull be exerted in a direction parallel to the line of action of the resistance, or a line joining the centers of the two blocks, in order to obtain the maximum effect. If the rope pulls on the lower block at an angle, the block will be pulled out of the line drawn between the load and the upper block, and the effective pull will be less than the actual pull on the rope in the ratio of the cosine of the angle the pulling rope makes with the vertical, or line of action of the resistance, to unity.

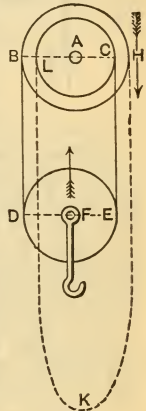

FIG. 119.

**Differential Pulley.** (Fig. 119.) — Two pulleys,  $B$  and  $C$ , of different radii, rotate as one piece about a fixed axis,  $A$ . An endless chain,  $BDECLKH$ , passes over both pulleys. The rims of the pulleys are shaped so as to hold the chain and prevent it from slipping. One of the bights or loops in which the chain hangs,  $DE$ , passes under and supports the running block  $F$ . The other loop or bight,  $HKL$ , hangs freely, and is called the hauling part. It is evident that the velocity of the hauling part is equal to that of the pitch-circle of the pulley  $B$ .

In order that the velocity-ratio may be exactly uniform, the radius of the sheave  $F$  should be an exact mean between the radii of  $B$  and  $C$ .

Consider that the point  $B$  of the cord  $BD$  moves through an arc whose length =  $AB$ , during the same time the point  $C$  or the cord  $CE$  will move downward a distance =  $AC$ . The length of the bight or loop  $BDEC$  will be shortened by  $AB - AC$ , which will cause the pulley  $F$  to be raised half of this amount. If  $P$  = the pulling force on the cord  $HK$ , and  $W$  the weight lifted at  $F$ , then  $P \times AB = W \times 1/2 (AB - AC)$ .

To calculate the length of chain required for a differential pulley, take the following sum: Half the circumference of  $A$  + half the circumference of  $B$  + half the circumference of  $F$  + twice the greatest distance of  $F$  from  $A$  + the least length of loop  $HKL$ . The last quantity is fixed according to convenience.

**A Wheel and Axle, or Windlass,** resembles two pulleys on one axis, having different diameters. If a weight be lifted by means of a rope wound over the axle, the force being applied at the rim of the wheel, the action is like that of a lever of which the shorter arm is equal to the radius of the axle plus half the thickness of the rope, and the longer arm is equal to the radius of the wheel. A wheel and axle is therefore sometimes classed as a perpetual lever. If  $P$  = the applied force,  $D$  = diameter of the wheel,  $W$  = the weight lifted, and  $d$  the diameter of the axle + the diameter of the rope,  $PD = Wd$ .

**Toothed-wheel Gearing** is a combination of two or more wheels and axles (Fig. 120). If a series of wheels and pinions gear into each other, as in the cut, friction neglected, the weight lifted, or resistance overcome, is to the force applied inversely as the distances through which

they act in a given time. If  $R, R_1, R_2$  be the radii of the successive wheels, measured to the pitch-line of the teeth, and  $r, r_1, r_2$  the radii of the corresponding pinions,  $P$  the applied force, and  $W$  the weight lifted,  $P \times R \times R_1 \times R_2 = W \times r \times r_1 \times r_2$ , or the applied force is to the weight as the product of the radii of the pinions is to the product of the radii of the wheels; or, as the product of the numbers expressing the teeth in each pinion is to the product of the numbers expressing the teeth in each wheel.

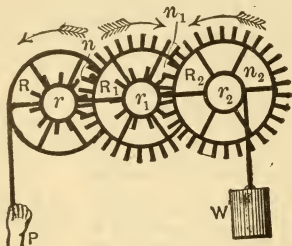

FIG. 120.

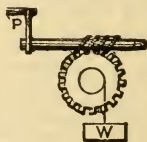

FIG. 121.

**Endless Screw, or Worm-gear.** (Fig. 121.)—This gear is commonly used to convert motion at high speed into motion at very slow speed. When the handle  $P$  describes a complete circumference, the pitch-line of the cog-wheel moves through a distance equal to the pitch of the screw, and the weight  $W$  is lifted a distance equal to the pitch of the screw multiplied by the ratio of the diameter of the axle to the diameter of the pitch-circle of the wheel. The ratio of the applied force to the weight lifted is inversely as their velocities, friction not being considered; but the friction in the worm-gear is usually very great, amounting sometimes to three or four times the useful work done.

If  $v$  = the distance through which the force  $P$  acts in a given time, say 1 second, and  $V$  = distance the weight  $W$  is lifted in the same time,  $r$  = radius of the crank or wheel through which  $P$  acts,  $t$  = pitch of the screw, and also of the teeth on the cog-wheel,  $d$  = diameter of the axle, and

$$D = \text{diameter of the pitch-line of the cog-wheel, } v = \frac{6.283 r D}{t} \times V;$$

$$V = v \times td \div 6.283 r D. \quad Pv = WV + \text{friction.}$$

**The Differential Windlass** (Fig. 122) is identical in principle with the differential pulley, the difference in construction being that in the differential windlass the running block hangs in the bight of a rope whose two parts are wound round, and have their ends respectively made fast to two barrels of different radii, which rotate as one piece about the axis  $A$ . The differential windlass is little used in practice, because of the great length of rope which it requires.

**The Differential Screw** (Fig. 123) is a compound screw of different pitches, in which the threads wind the same way.  $N_1$  and  $N_2$  are the two nuts;  $S_1S_1$ , the longer-pitched thread;  $S_2S_2$ , the shorter-pitched thread: in the figure both these threads are left-handed. At

each turn of the screw the nut  $N_2$  advances relatively to  $N_1$  through a distance equal to the difference of the pitches. The use of the differential screw is to combine the slowness of advance due to a fine pitch with the strength of thread which can be obtained by means of a coarse pitch only.

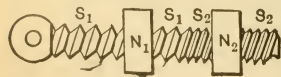

FIG. 123.

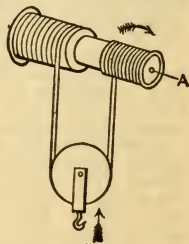

FIG. 122.

**Efficiency of a Differential Screw.**—A correspondent of the *American Machinist* describes an experiment with a differential screw-punch, consisting of an outer screw 2 inch diameter, 3 threads per inch, and an inner screw  $1\frac{3}{8}$  inch diameter,  $3\frac{1}{2}$  threads per inch. The pitch of the outer screw being  $\frac{1}{3}$  inch and that of the inner screw  $\frac{2}{7}$  inch the punch would advance in one revolution  $\frac{1}{3} - \frac{2}{7} = \frac{1}{21}$  inch. Experiments were made to determine the force required to punch an  $\frac{1}{16}$ -inch hole in iron  $\frac{1}{4}$  inch thick, the force being applied at the end of a lever-arm of  $47\frac{3}{4}$  inch. The leverage would be  $47\frac{3}{4} \times 2\pi \times 21 = 6300$ . The mean force applied at the end of the lever was 95 pounds, and the force at the punch, if there was no friction, would be  $6300 \times 95 = 598,500$  pounds. The force required to punch the iron, assuming a shearing resistance of 50,000 pounds per square inch, would be  $50,000 \times \frac{1}{16} \times \pi \times \frac{1}{4} = 27,000$  pounds, and the efficiency of the punch would be  $27,000 \div 598,500 =$  only 4.5 per cent. With the larger screw only used as a punch the mean force at the end of the lever was only 82 pounds. The leverage in this case was  $47\frac{3}{4} \times 2\pi \times 3 = 900$ , the total force referred to the punch, including friction,  $900 \times 82 = 73,800$ , and the efficiency  $27,000 \div 73,800 = 36.7$  per cent. The screws were of tool-steel, well fitted, and lubricated with lard-oil and plumbago.

### STRESSES IN FRAMED STRUCTURES.

Framed structures in general consist of one or more triangles, for the reason that the triangle is the one polygonal form whose shape cannot be changed without distorting one of its sides. Problems in stresses of simple framed structures may generally be solved either by the application of the triangle, parallelogram, or polygon of forces, by the principle of the lever, or by the method of moments. We shall give a few examples, referring the student to the works of Burr, Dubois, Johnson, and others for more elaborate treatment of the subject.

1. **A Simple Crane.** (Figs. 124 and 125.)— $A$  is a fixed mast,  $B$  a brace or boom,  $T$  a tie, and  $P$  the load. Required the strains in  $B$  and  $T$ . The weight  $P$ , considered as acting at the end of the boom, is held in equilibrium by three forces: first, gravity acting downwards; second, the tension in  $T$ ; and third, the thrust of  $B$ . Let the length of the line  $p$  represent the magnitude of the downward force exerted by the load, and draw a parallelogram with sides  $bt$  parallel, respectively, to  $B$  and  $T$ , such that  $p$  is the diagonal of the parallelogram. Then  $b$  and  $t$  are the components drawn to the same scale as  $p$ ,  $p$  being the resultant. Then if the length  $p$  represents the load,  $t$  is the tension in the tie, and  $b$  is the compression in the brace.

Or, more simply,  $T$ ,  $B$ , and that portion of the mast included between them or  $A'$  may represent a triangle of forces, and the forces are proportional to the length of the sides of the triangle; that is, if the height of the

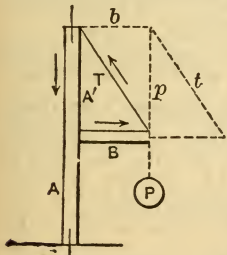

FIG. 124.

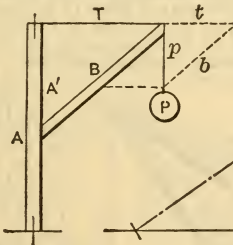

FIG. 125.

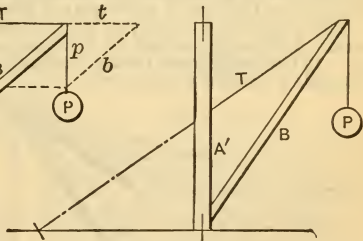

FIG. 126.

triangle  $A' =$  the load, then  $B =$  the compression in the brace, and  $T =$  the tension in the tie; or if  $P =$  the load in pounds, the tension in  $T = P \times \frac{T}{A'}$ , and the compression in  $B = P \times \frac{B}{A'}$ . Also, if  $a =$  the angle the inclined member makes with the mast, the other member being



horizontal, and the triangle being right-angled, then the length of the inclined member = height of the triangle  $\times$  secant  $a$ , and the strain in the inclined member =  $P$  secant  $a$ . Also, the strain in the horizontal member =  $P \tan a$ .

The solution by the triangle or parallelogram of forces, and the equations Tension in  $T = P \times T/A'$ , and Compression in  $B = P \times B/A'$ , hold true even if the triangle is not right-angled, as in Fig. 126; but the trigonometrical relations above given do not hold, except in the case of a right-angled triangle. It is evident that as  $A'$  decreases, the strain in both  $T$  and  $B$  increases, tending to become infinite as  $A'$  approaches zero. If the tie  $T$  is not attached to the mast, but is extended to the ground, as shown in the dotted line, the tension in it remains the same.

**2. A Guyed Crane or Derrick.** (Fig. 127.) — The strain in  $B$  is, as before,  $P \times B/A'$ ,  $A'$  being that portion of the vertical included between  $B$  and  $T$ , wherever  $T$  may be attached to  $A$ . If, however, the tie  $T$  is attached to  $B$  beneath its extremity, there may be in addition a bending strain in  $B$  due to a tendency to turn about the point of attachment of  $T$  as a fulcrum.

The strain in  $T$  may be calculated by the principle of moments. The moment of  $P$  is  $Pc$ , that is, its weight  $\times$  its perpendicular distance from the point of rotation of  $B$  on the mast. The moment of the strain on  $T$  is the product of the strain into the perpendicular distance from the line

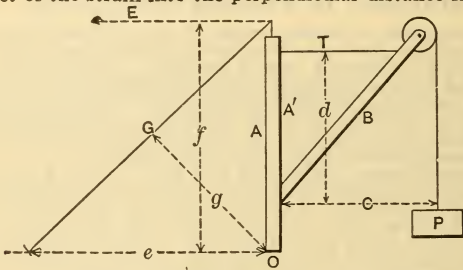

FIG. 127.

of its direction to the same point of rotation of  $B$ , or  $Td$ . The strain in  $T$  therefore =  $Pc \div d$ . As  $d$  decreases, the strain on  $T$  increases, tending to infinity as  $d$  approaches zero.

The strain on the guy-rope is also calculated by the method of moments. The moment of the load about the bottom of the mast  $O$  is, as before,  $Pc$ . If the guy is horizontal, the strain in it is  $F$  and its moment is  $Ff$ , and  $F = Pc \div f$ . If it is inclined, the moment is the strain  $G \times$  the perpendicular distance of the line of its direction from  $O$ , or  $Gg$ , and  $G = Pc \div g$ .

The guy-rope having the least strain is the horizontal one  $F$ , and the strain in  $G =$  the strain in  $F \times$  the secant of the angle between  $F$  and  $G$ . As  $G$  is made more nearly vertical  $g$  decreases, and the strain increases, becoming infinite when  $g = 0$ .

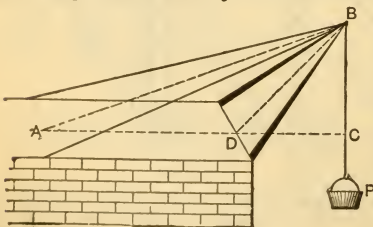

FIG. 128.

**3. Shear-poles with Guys.**

(Fig. 128.) — First assume that the two masts act as one placed at  $BD$ , and the two guys as one at  $AB$ . Calculate the strain in  $BD$  and  $AB$  as in Fig. 126. Multiply half the strain in  $BD$  (or  $AB$ ) by the secant of half the angle the two masts (or guys) make with each other to find the strain in each mast (or guy).

**Two Diagonal Braces and a Tie-rod.**

(Fig. 129.) — Suppose the braces are used to sustain a single load  $P$ . Compressive stress on  $AD = \frac{1}{2} P \times AD \div AB$ ; on  $CA = \frac{1}{2} P \times CA \div AB$ . This is true only if  $CB$  and  $BD$

sustain a single load  $P$ . Compressive stress on  $AD = \frac{1}{2} P \times AD \div AB$ ; on  $CA = \frac{1}{2} P \times CA \div AB$ . This is true only if  $CB$  and  $BD$

are of equal length, in which case  $\frac{1}{2}$  of  $P$  is supported by each abutment  $C$  and  $D$ . If they are unequal in length (Fig. 130), then, by the principle of the lever, find the reactions of the abutments  $R_1$  and  $R_2$ . If  $P$  is the load applied at the point  $B$  on the lever  $CD$ , the fulcrum being  $D$ , then  $R_1 \times CD = P \times BD$  and  $R_2 \times CD = P \times BC$ ;  $R_1 = P \times BD \div CD$ ;  $R_2 = P \times BC \div CD$ .

The strain on  $AC = R_1 \times AC \div AB$ , and on  $AD = R_2 \times AD \div AB$ .

The strain on the tie =  $R_1 \times CB \div AB = R_2 \times BD \div AB$ .

When  $CB = BD$ ,  $R_1 = R_2$ , and the strain on the tie is equal to  $\frac{1}{2}P \times \frac{1}{2}CD \div AB$ .

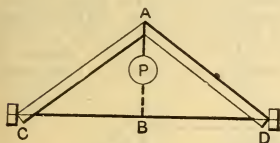

FIG. 129.

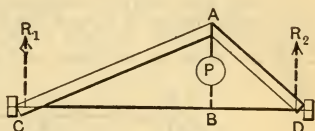

FIG. 130.

If the braces support a uniform load, as a pair of rafters, the strains caused by such a load are equivalent to that caused by one-half of the load applied at the center. The horizontal thrust of the braces against each other at the apex equals the tensile strain in the tie.

**King-post Truss or Bridge.** (Fig. 131.) — If the load is distributed over the whole length of the truss, the effect is the same as if half the load were placed at the center, the other half being carried by the abutments. Let

$P =$  one-half the load on the truss, then tension in the vertical tie  $AB = P$ . Compression in each of the inclined braces =  $\frac{1}{2}P \times AD \div AB$ . Tension in the tie  $CD = \frac{1}{2}P \times BD \div AB$ . Horizontal thrust of inclined brace  $AD$  at  $D =$  the tension in the tie. If  $W =$  the total load on one truss uniformly distributed,  $l =$  its length and  $d =$  its depth, then

the tension on the horizontal tie =  $Wl \div 8d$ .

**Inverted King-post Truss.** (Fig. 132) — If  $P =$  a load applied at  $B$ , or one-half of a uniformly distributed load, then compression on  $AB = P$  (the floor-beam  $CD$  not being considered to have any resistance to a slight bending). Tension on  $AC$  or  $AD = \frac{1}{2}P \times AD \div AB$ . Compression on  $CD = \frac{1}{2}P \times BD \div AB$ .

**Queen-post Truss.** (Fig. 133.) — If uniformly loaded, and the queen-posts divide the length into three equal bays, the load may be considered to be divided into three equal parts, two parts of which,  $P_1$  and  $P_2$ , are concentrated at the panel joints and the remainder

is equally divided between the abutments and supported by them directly. The two parts  $P_1$  and  $P_2$  only are considered to affect the members of the truss. Strain in the vertical ties  $BE$  and  $CF$  each equals  $P_1$  or  $P_2$ . Strain on  $AB$  and  $CD$  each =  $P_1 \times CD \div CF$ . Strain on the tie  $AE$  or  $ED = P_1 \times FD \div CF$ . Thrust on  $BC =$  tension on  $EF$ .

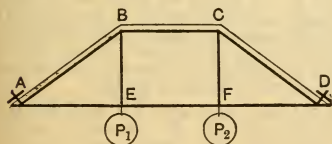

FIG. 133.

For stability to resist heavy unequal loads the queen-post truss should have diagonal braces from  $B$  to  $F$  and from  $C$  to  $E$ .

FIG. 132.

**Inverted Queen-post Truss.** (Fig. 134.) — Compression on *EB* and *FC* each =  $P_1$  or  $P_2$ . Compression on *AB* or *BC* or *CD* =  $P_1 \times AB \div EB$ . Tension on *AE* or *FD* =  $P_1 \times AE \div EB$ . Tension on *EF* = compression on *BC*. For stability to resist unequal loads, ties should be run from *C* to *E* and from *B* to *F*.

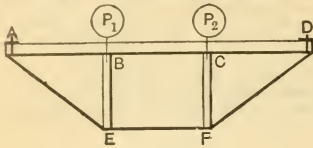

FIG. 134

and *CD* the truss may be considered as a queen-post truss, with the loads  $P_1, P_2$  concentrated at *E*, and the loads  $P_3, P_4$  concentrated at *F*. Then compressive strain on *AB* =  $(P_1 + P_2) \times AB \div BE$ . The strain on *CD* is the same if the loads and panel lengths are equal. The tensile

**Burr Truss of Five Panels.** (Fig. 135.) — Four-fifths of the load may be taken as concentrated at the points *E, K, L* and *F*, the other fifth being supported directly by the two abutments. For the strains in *BA*

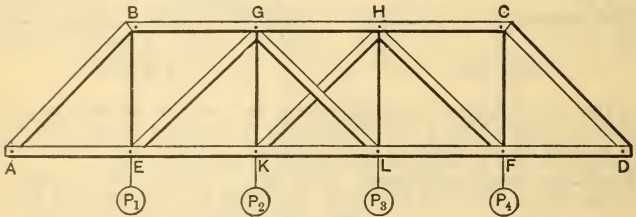

FIG. 135.

strain on *BE* or *CF* =  $P_1 + P_2$ . That portion of the truss between *E* and *F* may be considered as a smaller queen-post truss, supporting the loads  $P_2, P_3$  at *K* and *L*. The strain on *EG* or *HF* =  $P_2 \times EG \div GK$ . The diagonals *GL* and *KH* receive no strain unless the truss is unequally loaded. The verticals *GK* and *HL* each receive a tensile strain equal to  $P_2$  or  $P_3$ .

For the strain in the horizontal members: *BG* and *CH* receive a thrust equal to the horizontal component of the thrust in *AB* or *CD*, =  $(P_1 + P_2) \times \tan$  angle *ABE*, or  $(P_1 + P_2) \times AE \div BE$ . *GH* receives this thrust, and also, in addition, a thrust equal to the horizontal component of the thrust in *EG* or *HF*, or, in all,  $(P_1 + P_2 + P_3) \times AE \div BE$ .

The tension in *AE* or *FD* equals the thrust in *BG* or *HC*, and the tension in *EK, KL, and LF* equals the thrust in *GH*.

**Pratt or Whipple Truss.** (Fig. 136.) — In this truss the diagonals are ties, and the verticals are struts or columns.

*Calculation by the method of distribution of strains:* Consider first the load  $P_1$ . The truss having six bays or panels,  $5/6$  of the load is transmitted to the abutment *H*, and  $1/6$  to the abutment *O*, on the principle of the lever. As the five-sixths must be transmitted through *JA* and *AH*, write on these members the figure 5. The one-sixth is transmitted successively through *JC, CK, KD, DL*, etc., passing alternately through a tie and a strut. Write on these members, up to the strut *GO* inclusive, the figure 1. Then consider the load  $P_2$ , of which  $4/6$  goes to *AH* and  $2/6$  to *GO*. Write on *KB, BJ, JA*, and *AH* the figure 4, and on *KD, DL, LE*, etc., the figure 2. The load  $P_3$  transmits  $3/6$  in each direction; write 3 on each of the members through which this stress passes, and so on for all the loads, when the figures on the several members will appear as on the cut. Adding them up, we have the following totals:

Tension on diagonals	{	<i>AJ</i>	<i>BH</i>	<i>BK</i>	<i>CJ</i>	<i>CL</i>	<i>DK</i>	<i>DM</i>	<i>EL</i>	<i>EN</i>	<i>FM</i>	<i>FO</i>	<i>GN</i>
		15	0	10	1	6	3	3	6	1	10	0	15
Compression on verticals	{	<i>AH</i>	<i>BJ</i>	<i>CK</i>	<i>DL</i>	<i>EM</i>	<i>FN</i>	<i>GO</i>					
		15	10	7	6	7	10	15					

Each of the figures in the first line is to be multiplied by  $1/6 P \times \secant$  of angle *H AJ*, or  $1/6 P \times AJ \div AH$ , to obtain the tension, and each



figure in the lower line is to be multiplied by  $\frac{1}{6} P$  to obtain the compression. The diagonals  $HB$  and  $FO$  receive no strain.

It is common to build this truss with a diagonal strut at  $HB$  instead of the post  $HA$  and the diagonal  $AJ$ ; in which case  $\frac{5}{6}$  of the load  $P$  is carried through  $JB$  and the strut  $BH$ , which latter then receives a strain  $= \frac{15}{6} P \times \sec \text{ of } HBJ$ .

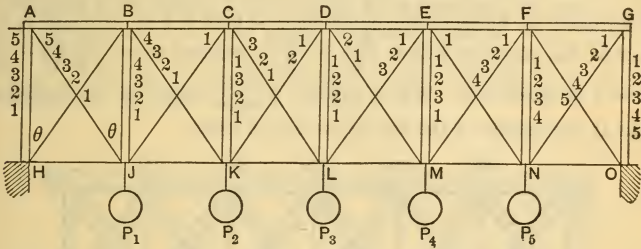

FIG. 136.

The strains in the upper and lower horizontal members or chords increase from the ends to the center, as shown in the case of the Burr truss.  $AB$  receives a thrust equal to the horizontal component of the tension in  $AJ$ , or  $\frac{15}{6} P \times \tan \text{ of } AJB$ .  $BC$  receives the same thrust + the horizontal component of the tension in  $BK$ , and so on. The tension in the lower chord of each panel is the same as the thrust in the upper chord of the same panel. (For calculation of the chord strains by the method of moments, see below.)

The maximum thrust or tension is at the center of the chords and is equal to  $\frac{WL}{8D}$ , in which  $W$  is the total load supported by the truss,  $L$  is the length, and  $D$  the depth. This is the formula for maximum stress in the chords of a truss of any form whatever.

The above calculation is based on the assumption that all the loads  $P_1, P_2$ , etc., are equal. If they are unequal, the value of each has to be taken into account in distributing the strains. Thus the tension in  $AJ$ , with unequal loads, instead of being  $15 \times \frac{1}{6} P \sec \theta$  would be  $\sec \theta \times (\frac{5}{6} P_1 + \frac{4}{6} P_2 + \frac{3}{6} P_3 + \frac{2}{6} P_4 + \frac{1}{6} P_5)$ . Each panel load,  $P_1$ , etc., includes its fraction of the weight of the truss.

**General Formula for Strains in Diagonals and Verticals.** — Let  $n$  = total number of panels,  $x$  = number of any vertical considered from the nearest end, counting the end as 1,  $r$  = rolling load for each panel,  $P$  = total load for each panel,

$$\text{Strain on verticals} = \frac{[(n-x) + (n-x)^2 - (x-1) + (x-1)^2] P}{2n} + \frac{r(x-1) + (x-1)^2}{2n}.$$

For a uniformly distributed load, leave out the last term,

$$[r(x-1) + (x-1)^2] \div 2n.$$

Strain on principal diagonals ( $AJ, GN$ , etc.) = strain on verticals  $\times \sec \theta$ , that is secant of the angle the diagonal makes with the vertical.

Strain on the counterbraces ( $BH, CJ, FO$ , etc.): The strain on the counterbrace in the first panel is 0, if the load is uniform. On the 2d, 3d, 4th, etc., it is  $P \sec \theta \times \frac{1}{n}, \frac{1+2}{n}, \frac{1+2+3}{n}$ , etc.,  $P$  being the total load in one panel.

**Strain in the Chords — Method of Moments.** — Let the truss be uniformly loaded, the total load acting on it =  $W$ . Weight supported at each end, or reaction of the abutment =  $W/2$ . Length of the truss =  $L$ . Weight on a unit of length =  $W/L$ . Horizontal distance from the nearest abutment to the point (say  $M$  in Fig. 136) in the chord where the strain is to be determined =  $x$ . Horizontal strain at that point (tension on the lower chord, compression in the upper) =  $H$ . Depth of the truss =  $D$ .

By the method of moments we take the difference of the moments, about the point  $M$ , of the reaction of the abutment and of the load between  $M$  and the abutments, and equate that difference with the moment of the resistance, or of the strain in the horizontal chord, considered with reference to a point in the opposite chord, about which the truss would turn if the first chord were severed at  $M$ .

The moment of the reaction of the abutment is  $Wx/2$ . The moment of the load from the abutment to  $M$  is  $(W/Lx) \times$  the distance of its center of gravity from  $M$ , which is  $x/2$ , or moment =  $Wx^2 \div 2L$ . Moment of the stress in the chord =  $HD = \frac{Wx}{2} - \frac{Wx^2}{2L}$ , whence  $H = \frac{W}{2D} \left( x - \frac{x^2}{L} \right)$ . If  $x = 0$  or  $L$ ,  $H = 0$ . If  $x = L/2$ ,  $H = \frac{WL}{8D}$ , which is the horizontal strain at the middle of the chords, as before given.

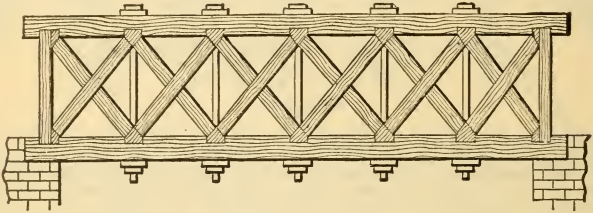

FIG. 137.

**The Howe Truss.** (Fig. 137.) — In the Howe truss the diagonals are struts, and the verticals are ties. The calculation of strains may be made in the same method as described above for the Pratt truss.

**The Warren Girder.** (Fig. 138.) — In the Warren girder, or triangular truss, there are no vertical struts, and the diagonals may transmit either tension or compression. The strains in the diagonals may be calculated by the method of distribution of strains as in the case of the rectangular truss.

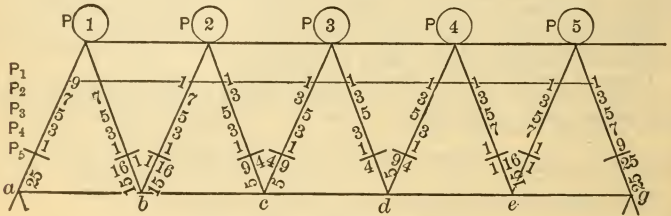

FIG. 138.

On the principle of the lever, the load  $P_1$  being  $1/10$  of the length of the span from the line of the nearest support  $a$ , transmits  $9/10$  of its weight to  $a$  and  $1/10$  to  $g$ . Write 9 on the right hand of the strut  $1a$ , to represent the compression, and 1 on the right hand of  $1b$ ,  $2c$ ,  $3d$ , etc., to represent tension, and on the left hand of  $b2$ ,  $c3$ , etc., to represent tension. The load  $P_2$  transmits  $7/10$  of its weight to  $a$  and  $3/10$  to  $g$ . Write 7 on each member from 2 to  $a$ , and 3 on each member from 2 to  $g$ , placing the figures representing compression on the right hand of the member, and those representing tension on the left. Proceed in the same manner with all the loads, then sum up the figures on each side of each diagonal, and write the difference of each sum beneath, and on the side of the greater sum, to show whether the difference represents tension or compression. The results are as follows: Compression,  $1a$ , 25;  $2b$ , 15;  $3c$ , 5;  $3d$ , 5;  $4e$ , 15;  $5g$ , 25. Tension,  $1b$ , 15;  $2c$ , 5;  $4d$ , 5;  $5e$ , 15. Each of these figures is to

be multiplied by  $1/10$  of one of the loads as  $P_1$ , and by the secant of the angle the diagonals make with a vertical line.

The strains in the horizontal chords may be determined by the method of moments as in the case of rectangular trusses.

**Roof-truss.** — *Solution by Method of Moments.* — The calculation of strains in structures by the method of statical moments consists in taking a cross-section of the structure at a point where there are not more than three members (struts, braces, or chords).

To find the strain in either one of these members take the moment about the intersection of the other two as an axis of rotation. The sum of the moments of these members must be 0 if the structure is in equilibrium. But the moments of the two members that pass through the point of reference or axis are both 0, hence one equation containing one unknown quantity can be found for each cross-section.

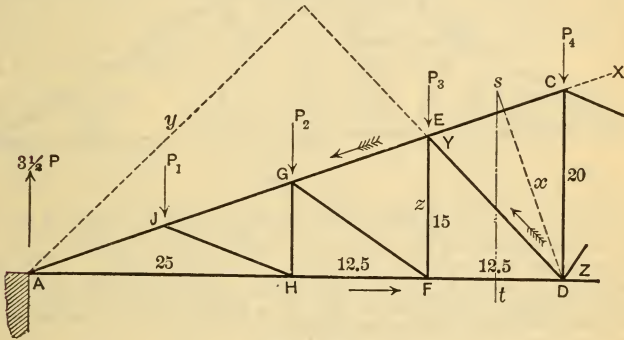

FIG. 139.

In the truss shown in Fig. 139 take a cross-section at  $ts$ , and determine the strain in the three members cut by it, viz.,  $CE$ ,  $ED$ , and  $DF$ . Let  $X$  = force exerted in direction  $CE$ ,  $Y$  = force exerted in direction  $DE$ ,  $Z$  = force exerted in direction  $FD$ .

For  $X$  take its moment about the intersection of  $Y$  and  $Z$  at  $D = Xx$ . For  $Y$  take its moment about the intersection of  $X$  and  $Z$  at  $A = Yy$ . For  $Z$  take its moment about the intersection of  $X$  and  $Y$  at  $E = Zz$ . Let  $z = 15$ ,  $x = 18.6$ ,  $y = 38.4$ ,  $AD = 50$ ,  $CD = 20$  ft. Let  $P_1, P_2, P_3, P_4$  be equal loads, as shown, and  $3\frac{1}{2}P$  the reaction of the abutment  $A$ .

The sum of all the moments taken about  $D$  or  $A$  or  $E$  will be 0 when the structure is at rest. Then  $-Xx + 3.5P \times 50 - P_3 \times 12.5 - P_2 \times 25 - P_1 \times 37.5 = 0$ .

The + signs are for moments in the direction of the hands of a watch or "clockwise" and - signs for the reverse direction or anti-clockwise. Since  $P = P_1 = P_2 = P_3$ ,  $-18.6X + 175P - 75P = 0$ ;  $-18.6X = -100P$ ;  
 $X = 100P \div 18.6 = 5.376P$ .

$-Yy + P_3 \times 37.5 + P_2 \times 25 \div P_1 \times 12.5 = 0$ ;  $38.4Y = 75$ ;  $Y = 75P \div 38.4 = 1.953P$ .

$-Zz + 3.5P \times 37.5 - P_1 \times 25 - P_2 \times 12.5 - P_3 \times 0 = 0$ ;  $15Z = 93.75P$ ;  $Z = 6.25P$ .

In the same manner the forces exerted in the other members have been found as follows:  $EG = 6.73P$ ;  $GJ = 8.07P$ ;  $JA = 9.42P$ ;  $JH = 1.35P$ ;  $GF = 1.59P$ ;  $AH = 8.75P$ ;  $HF = 7.50P$ .

**The Fink Roof-truss.** (Fig. 140.) — An analysis by Prof. P. H. Philbrick (*Van N. Mag.*, Aug., 1880) gives the following results:

$W$  = total load on roof;

$N$  = No. of panels on both rafters;

$W/N = P$  = load at each joint  $b, d, f$ , etc.;

$V$  = reaction at  $A = \frac{1}{2}W = \frac{1}{2}NP = 4P$ ;

$AD = S$ ;  $AC = L$ ;  $CD = D$ ;

$t_1, t_2, t_3$  = tension on  $De, eg, gA$ , respectively;

$c_1, c_2, c_3, c_4$  = compression on  $Cb, bd, df$ , and  $fA$ .



Strains in

- |                                       |  |
|---------------------------------------|--|
| 1, or $De = t_1 = 2 PS \div D$ ;      | 7, or $bC = c_1 = 7/2 PL/D - 3 PD/L$ ; |
| 2, " $eg = t_2 = 3 PS \div D$ ;       | 8, " $bc$ or $fg = PS \div L$ ;        |
| 3, " $gA = t_3 = 7/2 PS \div D$ ;     | 9, " $de = 2 PS \div L$ ;              |
| 4, " $Af = c_4 = 7/2 PL \div D$ ;     | 10, " $cd$ or $dg = 1/2 PS \div D$ ;   |
| 5, " $fd = c_3 = 7/2 PL/D - PD/L$ ;   | 11, " $ec = PS \div D$ ;               |
| 6, " $db = c_2 = 7/2 PL/D - 2 PD/L$ ; | 12, " $cG = 3/2 PS \div D$ .           |

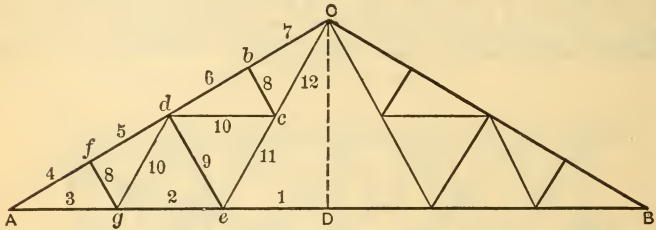

FIG. 140.

**EXAMPLE.** — Given a Fink roof-truss of span 64 ft., depth 16 ft., with four panels on each side, as in *hecut*; total load 32 tons, or 4 tons each at the points *f, d, b, C*, etc. (and 2 tons each at *A* and *B*, which transmit no strain to the truss members). Here  $W = 32$  tons,  $P = 4$  tons,  $S = 32$  ft.,  $D = 16$  ft.,  $L = \sqrt{S^2 + D^2} = 2.236 \times D$ .  $L \div D = 2.236$ ,  $D \div L = 0.4472$ ,  $S \div D = 2$ ,  $S \div L = 0.8944$ . The strains on the numbered members then are as follows:

1, $2 \times 4 \times 2 = 16$ tons;	7, $31.3 - 12 \times 0.447 = 25.94$ tons.
2, $3 \times 4 \times 2 = 24$ "	8, $4 \times 0.8944 = 3.58$ "
3, $7/2 \times 4 \times 2 = 28$ "	9, $8 \times 0.8944 = 7.16$ "
4, $7/2 \times 4 \times 2.236 = 31.3$ "	10, $2 \times 2 = 4$ "
5, $31.3 - 4 \times 0.447 = 29.52$ "	11, $4 \times 2 = 8$ "
6, $31.3 - 8 \times 0.447 = 27.72$ "	12, $6 \times 2 = 12$ "

**The Economical Angle.** — A structure of triangular form, Fig. 141, is supported at *a* and *b*. It sustains any load *L*, the elements *cc* being in compression and *t* in tension. Required the angle  $\theta$  so that the total weight of the structure shall be a minimum. F. R. Honey (*Sci. Am. Supp.*, Jan. 17, 1891) gives a solution of this problem, with the

result  $\tan \theta = \sqrt{\frac{C+T}{T}}$ , in which *C* and *T* represent

the crushing and the tensile strength respectively of the material employed. It is applicable to any material. For  $C = T$ ,  $\theta = 54\frac{3}{4}^\circ$ . For  $C = 0.4 T$  (yellow pine),  $\theta = 49\frac{3}{4}^\circ$ . For  $C = 0.8 T$  (soft steel),  $\theta = 53\frac{1}{4}^\circ$ . For  $C = 6 T$  (cast iron),  $\theta = 69\frac{1}{4}^\circ$ .

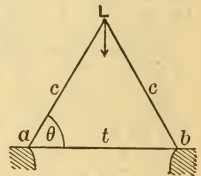

FIG. 141.

## HEAT.

### THERMOMETERS.

The Fahrenheit thermometer is generally used in English-speaking countries, and the Centigrade, or Celsius, thermometer in countries that use the metric system. In many scientific treatises in English, however, the Centigrade temperatures are also used, either with or without their Fahrenheit equivalents. The Réaumur thermometer is used to some extent on the Continent of Europe and in breweries in this country.

In the Fahrenheit thermometer the freezing-point of water is taken at 32°, and the boiling-point of water at mean atmospheric pressure at the sea-level, 14.7 lbs. per sq. in., is taken at 212°, the distance between these two points being divided into 180°. In the Centigrade and Réaumur thermometers the freezing-point is taken at 0°. The boiling-point is 100° in the Centigrade scale, and 80° in the Réaumur.

1 Fahrenheit degree	= 5/9 deg. Centigrade	= 4/9 deg. Réaumur.
1 Centigrade degree	= 9/5 deg. Fahrenheit	= 4/5 deg. Réaumur.
1 Réaumur degree	= 9/4 deg. Fahrenheit	= 5/4 deg. Centigrade.
Temperature Fahrenheit	= 9/5 × temp. C. + 32°	= 9/4 R. + 32°.
Temperature Centigrade	= 5/9 (temp. F. - 32°)	= 5/4 R.
Temperature Réaumur	= 4/5 temp. C.	= 4/9 (F. - 32°).

**HANDY RULE FOR CONVERTING CENTIGRADE TEMPERATURE TO FAHRENHEIT.** — Multiply by 2, subtract a tenth, add 32.

**EXAMPLE.** — 100° C. × 2 = 200, - 20 = 180, + 32 = 212° F.

**Mercurial Thermometer.** (Rankine, *S. E.*, p. 234.) — The rate of expansion of mercury with rise of temperature increases as the temperature becomes higher; from which it follows, that if a thermometer showing the dilatation of mercury simply were made to agree with an air thermometer at 32° and 212°, the mercurial thermometer would show lower temperatures than the air thermometer between those standard points, and higher temperatures beyond them.

For example, according to Regnault, when the air thermometer marked 350° C. (= 662° F.), the mercurial thermometer would mark 362.16° C. (= 683.89° F.), the error of the latter being in excess 12.16° C. (= 21.89° F.).

Actual mercurial thermometers indicate intervals of temperature proportional to the difference between the expansion of mercury and that of glass.

The inequalities in the rate of expansion of the glass (which are very different for different kinds of glass) correct, to a greater or less extent, the errors arising from the inequalities in the rate of expansion of the mercury.

For practical purposes connected with heat engines, the mercurial thermometer made of common glass may be considered as sensibly coinciding with the air-thermometer at all temperatures not exceeding 500° F.

If the mercury is not throughout its whole length at the same temperature as that being measured, a correction, *k*, must be added to the temperature *t* in Fahrenheit degrees;  $k = 95 D (t - t') \div 1,000,000$ , where *D* is the length of the mercury column exposed, measured in Fahrenheit degrees, and *t* is the temperature of the exposed part of the thermometer. When long thermometers are used in shallow wells in high-pressure steam pipes this correction is often 5° to 10° F. (Moyer on Steam Turbines.)

## PYROMETRY.

### Principles Used in Various Pyrometers.

Pyrometers may be classified according to the principles upon which they operate, as follows:

1. Expansion of mercury in a glass tube. When the space above the mercury is filled with compressed nitrogen, and a specially hard glass is used for the tube, mercury thermometers may be made to indicate temperatures as high as 1000° F.

TEMPERATURES, CENTIGRADE AND FAHRENHEIT.

C.	F.	C.	F.	C.	F.	C.	F.	C.	F.	C.	F.	C.	F.
-40	-40.	26	78.8	92	197.6	158	316.4	224	435.2	290	554	950	1742
-39	-38.2	27	80.6	93	199.4	159	318.2	225	437.	300	572	960	1760
-38	-36.4	28	82.4	94	201.2	160	320.	226	438.8	310	590	970	1778
-37	-34.6	29	84.2	95	203.	161	321.8	227	440.6	320	608	980	1796
-36	-32.8	30	86.	96	204.8	162	323.6	228	442.4	330	626	990	1814
-35	-31.	31	87.8	97	206.6	163	325.4	229	444.2	340	644	1000	1832
-34	-29.2	32	89.6	98	208.4	164	327.2	230	446.	350	662	1010	1850
-33	-27.4	33	91.4	99	210.2	165	329.	231	447.8	360	680	1020	1868
-32	-25.6	34	93.2	100	212.	166	330.8	232	449.6	370	698	1030	1886
-31	-23.8	35	95.	101	213.8	167	332.6	233	451.4	380	716	1040	1904
-30	-22.	36	96.8	102	215.6	168	334.4	234	453.2	390	734	1050	1922
-29	-20.2	37	98.6	103	217.4	169	336.2	235	455.	400	752	1060	1940
-28	-18.4	38	100.4	104	219.2	170	338.	236	456.8	410	770	1070	1958
-27	-16.6	39	102.2	105	221.	171	339.8	237	458.6	420	788	1080	1976
-26	-14.8	40	104.	106	222.8	172	341.6	238	460.4	430	806	1090	1994
-25	-13.	41	105.8	107	224.6	173	343.4	239	462.2	440	824	1100	2012
-24	-11.2	42	107.6	108	226.4	174	345.2	240	464.	450	842	1110	2030
-23	-9.4	43	109.4	109	228.2	175	347.	241	465.8	460	860	1120	2048
-22	-7.6	44	111.2	110	230.	176	348.8	242	467.6	470	878	1130	2066
-21	-5.8	45	113.	111	231.8	177	350.6	243	469.4	480	896	1140	2084
-20	-4.	46	114.8	112	233.6	178	352.4	244	471.2	490	914	1150	2102
-19	-2.2	47	116.6	113	235.4	179	354.2	245	473.	500	932	1160	2120
-18	-0.4	48	118.4	114	237.2	180	356.	246	474.8	510	950	1170	2138
-17	+ 1.4	49	120.2	115	239.	181	357.8	247	476.6	520	968	1180	2156
-16	3.2	50	122.	116	240.8	182	359.6	248	478.4	530	986	1190	2174
-15	5.	51	123.8	117	242.6	183	361.4	249	480.2	540	1004	1200	2192
-14	6.8	52	125.6	118	244.4	184	363.2	250	482.	550	1022	1210	2210
-13	8.6	53	127.4	119	246.2	185	365.	251	483.8	560	1040	1220	2228
-12	10.4	54	129.2	120	248.	186	366.8	252	485.6	570	1058	1230	2246
-11	12.2	55	131.	121	249.8	187	368.6	253	487.4	580	1076	1240	2264
-10	14.	56	132.8	122	251.6	188	370.4	254	489.2	590	1094	1250	2282
-9	15.8	57	134.6	123	253.4	189	372.2	255	491.	600	1112	1260	2300
-8	17.6	58	136.4	124	255.2	190	374.	256	492.8	610	1130	1270	2318
-7	19.4	59	138.2	125	257.	191	375.8	257	494.6	620	1148	1280	2336
-6	21.2	60	140.	126	258.8	192	377.6	258	496.4	630	1166	1290	2354
-5	23.	61	141.8	127	260.6	193	379.4	259	498.2	640	1184	1300	2372
-4	24.8	62	143.6	128	262.4	194	381.2	260	500.	650	1202	1310	2390
-3	26.6	63	145.4	129	264.2	195	383.	261	501.8	660	1220	1320	2408
-2	28.4	64	147.2	130	266.	196	384.8	262	503.6	670	1238	1330	2426
-1	30.2	65	149.	131	267.8	197	386.6	263	505.4	680	1256	1340	2444
0	32.	66	150.8	132	269.6	198	388.4	264	507.2	690	1274	1350	2462
+ 1	33.8	67	152.6	133	271.4	199	390.2	265	509.	700	1292	1360	2480
2	35.6	68	154.4	134	273.2	200	392.	266	510.8	710	1310	1370	2498
3	37.4	69	156.2	135	275.	201	393.8	267	512.6	720	1328	1380	2516
4	39.2	70	158.	136	276.8	202	395.6	268	514.4	730	1346	1390	2534
5	41.	71	159.8	137	278.6	203	397.4	269	516.2	740	1364	1400	2552
6	42.8	72	161.6	138	280.4	204	399.2	270	518.	750	1382	1410	2570
7	44.6	73	163.4	139	282.2	205	401.	271	519.8	760	1400	1420	2588
8	46.4	74	165.2	140	284.	206	402.8	272	521.6	770	1418	1430	2606
9	48.2	75	167.	141	285.8	207	404.6	273	523.4	780	1436	1440	2624
10	50.	76	168.8	142	287.6	208	406.4	274	525.2	790	1454	1450	2642
11	51.8	77	170.6	143	289.4	209	408.2	275	527.	800	1472	1460	2660
12	53.6	78	172.4	144	291.2	210	410.	276	528.8	810	1490	1470	2678
13	55.4	79	174.2	145	293.	211	411.8	277	530.6	820	1508	1480	2696
14	57.2	80	176.	146	294.8	212	413.6	278	532.4	830	1526	1490	2714
15	59.	81	177.8	147	296.6	213	415.4	279	534.2	840	1544	1500	2732
16	60.8	82	179.6	148	298.4	214	417.2	280	536.	850	1562	1510	2750
17	62.6	83	181.4	149	300.2	215	419.	281	537.8	860	1580	1520	2768
18	64.4	84	183.2	150	302.	216	420.8	282	539.6	870	1598	1530	2786
19	66.2	85	185.	151	303.8	217	422.6	283	541.4	880	1616	1540	2804
20	68.	86	186.8	152	305.6	218	424.4	284	543.2	890	1634	1550	2822
21	69.8	87	188.6	153	307.4	219	426.2	285	545.	900	1652	1600	2912
22	71.6	88	190.4	154	309.2	220	428.	286	546.8	910	1670	1650	3002
23	73.4	89	192.2	155	311.	221	429.8	287	548.6	920	1688	1700	3092
24	75.2	90	194.	156	312.8	222	431.6	288	550.4	930	1706	1750	3182
25	77.	91	195.8	157	314.6	223	433.4	289	552.2	940	1724	1800	3272



## TEMPERATURES, FAHRENHEIT AND CENTIGRADE.

F.	C.	F.	C.	F.	C.	F.	C.	F.	C.	F.	C.	F.	C.
-40	-40.	26	-3.3	92	33.3	158	70.	224	106.7	290	143.3	360	182.2
-39	-39.4	27	-2.8	93	33.9	159	70.6	225	107.2	291	143.9	370	187.8
-38	-38.9	28	-2.2	94	34.4	160	71.1	226	107.8	292	144.4	380	193.3
-37	-38.3	29	-1.7	95	35.	161	71.7	227	108.3	293	145.	390	198.9
-36	-37.8	30	-1.1	96	35.6	162	72.2	228	108.9	294	145.6	400	204.4
-35	-37.2	31	-0.6	97	36.1	163	72.8	229	109.4	295	146.1	410	210.
-34	-36.7	32	0.	98	36.7	164	73.3	230	110.	296	146.7	420	215.6
-33	-36.1	33	+0.6	99	37.2	165	73.9	231	110.6	297	147.2	430	221.1
-32	-35.6	34	1.1	100	37.8	166	74.4	232	111.1	298	147.8	440	226.7
-31	-35.	35	1.7	101	38.3	167	75.	233	111.7	299	148.3	450	232.2
-30	-34.4	36	2.2	102	38.9	168	75.6	234	112.2	300	148.9	460	237.8
-29	-33.9	37	2.8	103	39.4	169	76.1	235	112.8	301	149.4	470	243.3
-28	-33.3	38	3.3	104	40.	170	76.7	236	113.3	302	150.	480	248.9
-27	-32.8	39	3.9	105	40.6	171	77.2	237	113.9	303	150.6	490	254.4
-26	-32.2	40	4.4	106	41.1	172	77.8	238	114.4	304	151.1	500	260.
-25	-31.7	41	5.	107	41.7	173	78.3	239	115.	305	151.7	510	265.6
-24	-31.1	42	5.6	108	42.2	174	78.9	240	115.6	306	152.2	520	271.1
-23	-30.6	43	6.1	109	42.8	175	79.4	241	116.1	307	152.8	530	276.7
-22	-30.	44	6.7	110	43.3	176	80.	242	116.7	308	153.3	540	282.2
-21	-29.4	45	7.2	111	43.9	177	80.6	243	117.2	309	153.9	550	287.8
-20	-28.9	46	7.8	112	44.4	178	81.1	244	117.8	310	154.4	560	293.3
-19	-28.3	47	8.3	113	45.	179	81.7	245	118.3	311	155.	570	298.9
-18	-27.8	48	8.9	114	45.6	180	82.2	246	118.9	312	155.6	580	304.4
-17	-27.2	49	9.4	115	46.1	181	82.8	247	119.4	313	156.1	590	310.
-16	-26.7	50	10.	116	46.7	182	83.3	248	120.	314	156.7	600	315.6
-15	-26.1	51	10.6	117	47.2	183	83.9	249	120.6	315	157.2	610	321.1
-14	-25.6	52	11.1	118	47.8	184	84.4	250	121.1	316	157.8	620	326.7
-13	-25.	53	11.7	119	48.3	185	85.	251	121.7	317	158.3	630	332.2
-12	-24.4	54	12.2	120	48.9	186	85.6	252	122.2	318	158.9	640	337.8
-11	-23.9	55	12.8	121	49.4	187	86.1	253	122.8	319	159.4	650	343.3
-10	-23.3	56	13.3	122	50.	188	86.7	254	123.3	320	160.	660	348.9
-9	-22.8	57	13.9	123	50.6	189	87.2	255	123.9	321	160.6	670	354.4
-8	-22.2	58	14.4	124	51.1	190	87.8	256	124.4	322	161.1	680	360.
-7	-21.7	59	15.	125	51.7	191	88.3	257	125.	323	161.7	690	365.6
-6	-21.1	60	15.6	126	52.2	192	88.9	258	125.6	324	162.2	700	371.1
-5	-20.6	61	16.1	127	52.8	193	89.4	259	126.1	325	162.8	710	376.7
-4	-20.	62	16.7	128	53.3	194	90.	260	126.7	326	163.3	720	382.2
-3	-19.4	63	17.2	129	53.9	195	90.6	261	127.2	327	163.9	730	387.8
-2	-18.9	64	17.8	130	54.4	196	91.1	262	127.8	328	164.4	740	393.3
-1	-18.3	65	18.3	131	55.	197	91.7	263	128.3	329	165.	750	398.9
0	-17.8	66	18.9	132	55.6	198	92.2	264	128.9	330	165.6	760	404.4
+ 1	-17.2	67	19.4	133	56.1	199	92.8	265	129.4	331	166.1	770	410.
2	-16.7	68	20.	134	56.7	200	93.3	266	130.	332	166.7	780	415.6
3	-16.1	69	20.6	135	57.2	201	93.9	267	130.6	333	167.2	790	421.1
4	-15.6	70	21.1	136	57.8	202	94.4	268	131.1	334	167.8	800	426.7
5	-15.	71	21.7	137	58.3	203	95.	269	131.7	335	168.3	810	432.2
6	-14.4	72	22.2	138	58.9	204	95.6	270	132.2	336	168.9	820	437.8
7	-13.9	73	22.8	139	59.4	205	96.1	271	132.8	337	169.4	830	443.3
8	-13.3	74	23.3	140	60.	206	96.7	272	133.3	338	170.	840	448.9
9	-12.8	75	23.9	141	60.6	207	97.2	273	133.9	339	170.6	850	454.4
10	-12.2	76	24.4	142	61.1	208	97.8	274	134.4	340	171.1	860	460.
11	-11.7	77	25.	143	61.7	209	98.3	275	135.	341	171.7	870	465.6
12	-11.1	78	25.6	144	62.2	210	98.9	276	135.6	342	172.2	880	471.1
13	-10.6	79	26.1	145	62.8	211	99.4	277	136.1	343	172.8	890	476.7
14	-10.	80	26.7	146	63.3	212	100.	278	136.7	344	173.3	900	482.2
15	-9.4	81	27.2	147	63.9	213	100.6	279	137.2	345	173.9	910	487.8
16	-8.9	82	27.8	148	64.4	214	101.1	280	137.8	346	174.4	920	493.3
17	-8.3	83	28.3	149	65.	215	101.7	281	138.3	347	175.	930	498.9
18	-7.8	84	28.9	150	65.6	216	102.2	282	138.9	348	175.6	940	504.4
19	-7.2	85	29.4	151	66.1	217	102.8	283	139.4	349	176.1	950	510.
20	-6.7	86	30.	152	66.7	218	103.3	284	140.	350	176.7	960	515.6
21	-6.1	87	30.6	153	67.2	219	103.9	285	140.6	351	177.2	970	521.1
22	-5.6	88	31.1	154	67.8	220	104.4	286	141.1	352	177.8	980	526.7
23	-5.	89	31.7	155	68.3	221	105.	287	141.7	353	178.3	990	532.2
24	-4.4	90	32.2	156	68.9	222	105.6	288	142.2	354	178.9	1000	537.8
25	-3.9	91	32.8	157	69.4	223	106.1	289	142.8	355	179.4	1010	543.3

## Temperature Conversion Table.

(By Dr. Leonard Waldo.)

Reprint from *Metallurgical and Chemical Engineering*.

C°	0	10	20	30	40	50	60	70	80	90		
	F	F	F	F	F	F	F	F	F	F		
-200	-328	-346	-364	-382	-400	-418	-436	-454				
-100	-148	-166	-184	-202	-220	-238	-256	-274	-292	-310		
-0	+32	+14	-4	-22	-40	-58	-76	-94	-112	-130		
0	32	50	68	86	104	122	140	158	176	194		
100	212	230	248	266	284	302	320	338	356	374	C°	F°
200	392	410	428	446	464	482	500	518	536	554	1	1.8
300	572	590	608	626	644	662	680	698	716	734	2	3.6
400	752	770	788	806	824	842	860	878	896	914	3	5.4
500	932	950	968	986	1004	1022	1040	1058	1076	1094	4	7.2
600	1112	1130	1148	1166	1184	1202	1220	1238	1256	1274	5	9.0
700	1292	1310	1328	1346	1364	1382	1400	1418	1436	1454	6	10.8
800	1472	1490	1508	1526	1544	1562	1580	1598	1616	1634	7	12.6
900	1652	1670	1688	1706	1724	1742	1760	1778	1796	1814	8	14.4
1000	1832	1850	1868	1886	1904	1922	1940	1958	1976	1994	9	16.2
1100	2012	2030	2048	2066	2084	2102	2120	2138	2156	2174	10	18.0
1200	2192	2210	2228	2246	2264	2282	2300	2318	2336	2354		
1300	2372	2390	2408	2426	2444	2462	2480	2498	2516	2534		
1400	2552	2570	2588	2606	2624	2642	2660	2678	2696	2714		
1500	2732	2750	2768	2786	2804	2822	2840	2858	2876	2894		
1600	2912	2930	2948	2966	2984	3002	3020	3038	3056	3074		
1700	3092	3110	3128	3146	3164	3182	3200	3218	3236	3254	F°	C°
1800	3272	3290	3308	3326	3344	3362	3380	3398	3416	3434	1	.56
1900	3452	3470	3488	3506	3524	3542	3560	3578	3596	3614	2	1.11
2000	3632	3650	3668	3686	3704	3722	3740	3758	3776	3794	3	1.67
2100	3812	3830	3848	3866	3884	3902	3920	3938	3956	3974	4	2.22
2200	3992	4010	4028	4046	4064	4082	4100	4118	4136	4154	5	2.78
2300	4172	4190	4208	4226	4244	4262	4280	4298	4316	4334	6	3.33
2400	4352	4370	4388	4406	4424	4442	4460	4478	4496	4514	7	3.89
2500	4532	4550	4568	4586	4604	4622	4640	4658	4676	4694	8	4.44
2600	4712	4730	4748	4766	4784	4802	4820	4838	4856	4874	9	5.00
2700	4892	4910	4928	4946	4964	4982	5000	5018	5036	5054	10	5.56
2800	5072	5090	5108	5126	5144	5162	5180	5198	5216	5234	11	6.11
2900	5252	5270	5288	5306	5324	5342	5360	5378	5396	5414	12	6.67
3000	5432	5450	5468	5486	5504	5522	5540	5558	5576	5594	13	7.22
3100	5612	5630	5648	5666	5684	5702	5720	5738	5756	5774	14	7.78
3200	5792	5810	5828	5846	5864	5882	5900	5918	5936	5954	15	8.33
3300	5972	5990	6008	6026	6044	6062	6080	6098	6116	6134	16	8.89
3400	6152	6170	6188	6206	6224	6242	6260	6278	6296	6314	17	9.44
3500	6332	6350	6368	6386	6404	6422	6440	6458	6476	6494	18	10.00
3600	6512	6530	6548	6566	6584	6602	6620	6638	6656	6674		
3700	6692	6710	6728	6746	6764	6782	6800	6818	6836	6854		
3800	6872	6890	6908	6926	6944	6962	6980	6998	7016	7034		
3900	7052	7070	7088	7106	7124	7142	7160	7178	7196	7214		
C°	0	10	20	30	40	50	60	70	80	90		

EXAMPLES:  $1347^{\circ}\text{C} = 2444^{\circ}\text{F} + 12^{\circ}.6\text{F} = 2456^{\circ}.6\text{F}$ ;  $3367^{\circ}\text{F} = 1850^{\circ}\text{C} + 2^{\circ}.78\text{C} = 1852^{\circ}.78\text{C}$ . For other tables of temperatures, see pages 550 and 551.

2. Contraction of clay, as in the old Wedgwood pyrometer, at one time used by potters. This instrument was very inaccurate, as the contraction of clay varied with its nature.

3. Expansion of air, as in the air-thermometer, Wiborgh's pyrometer. Uehling and Steinbart's pyrometer, etc.

4. Pressure of vapors, as in some forms of Bristol's recording pyrometer.

5. Relative expansion of two metals or other substances, as in Brown's, Bulkeley's and other metallic pyrometers, consisting of a copper rod or tube inside of an iron tube, or *vice versa*, with the difference of expansion multiplied by gearing and indicated on a dial.

6. Specific heat of solids, as in the copper-ball and platinum-ball pyrometers.

7. Melting-points of metals, alloys, or other substances, as in approximate determination of temperature by melting pieces of zinc, lead, etc., or as in Seger's fire-clay pyrometer.

8. Time required to heat a weighed quantity of water inclosed in a vessel, as in one form of water pyrometer.

9. Increase in temperature of a stream of water or other liquid flowing at a given rate through a tube inserted into the heated chamber.

10. Changes in the electric resistance of platinum or other metal, as in the Siemens pyrometer.

11. Measurement of an electric current produced by heating the junction of two metals, as in the Le Chatelier pyrometer.

12. Dilution by cold air of a stream of hot air or gas flowing from a heated chamber and determination of the temperature of the mixture by a mercury thermometer, as in Hobson's hot-blast pyrometer.

13. Polarization and refraction by prisms and plates of light radiated from heated surfaces, as in Mesuré and Nouel's pyrometric telescope or optical pyrometer, and Wanner's pyrometer.

14. Heating the filament of an electric lamp to the same color as that of an incandescent body, so that when the latter is observed through a telescope containing the lamp the filament becomes invisible, as in Holborn and Kurlbaum's and Morse's optical pyrometers. The current required to heat the filament is a measure of the temperature.

15. The radiation pyrometer. The radiation from an incandescent surface is received in a telescope containing a thermo-couple, and the electric current generated therein is measured, as in Féry's radiation pyrometer.

(See "Optical Pyrometry" by C. W. W. Waidner and G. K. Burgess, Bulletin No. 2, Bureau of Standards, Department of Commerce and Labor; also *Eng'g*, Mar. 1, 1907.)

The "Veritas" Pyrometer (called Buller's Rings in England) is an improvement on the Wedgewood pyrometer. It is based on the contraction of a flat ring of a special clay mixture, which is made with great care to secure uniformity of composition. The contraction is found to be directly proportional to the increase of temperature above 800° C. (1472° F.) and its amount is measured by a multiplying index. The rings are 2½ in. external and ¾ in. internal diam., 5/16 in. thick. They are made by Veritas Firing System Co., Trenton, N. J., and are largely used by potters.

**Platinum or Copper Ball Pyrometer.** — A weighed piece of platinum, copper, or iron is allowed to remain in the furnace or heated chamber till it has attained the temperature of its surroundings. It is then suddenly taken out and dropped into a vessel containing water of a known weight and temperature. The water is stirred rapidly and its maximum temperature taken. Let  $W$  = weight of the water,  $w$  the weight of the ball,  $t$  = the original and  $T$  the final heat of the water, and  $S$  the specific heat of the metal; then the temperature of fire may be found from the formula

$$x = \frac{W(T - t)}{wS} + T.$$

The mean specific heat of platinum between 32° and 446° F. is 0.03333 or 1/30 that of water, and it increases with the temperature about 0.000305 for each 100° F. For a fuller description, by J. C. Hoadley, see *Trans. A. S. M. E.*, vi, 702. Compare also Henry M. Howe, *Trans. A. I. M. E.*, xviii, 728.

For accuracy corrections are required for variations in the specific heat



of the water and of the metal at different temperatures, for loss of heat by radiation from the metal during the transfer from the furnace to the water, and from the apparatus during the heating of the water; also for the heat-absorbing capacity of the vessel containing the water.

Fire-clay or fire-brick may be used instead of the metal ball.

**Le Chatelier's Thermo-electric Pyrometer.**—For a very full description, see paper by Joseph Struthers, *School of Mines Quarterly*, vol. xii, 1891; also, paper read by Prof. Roberts-Austen before the Iron and Steel Institute, May 7, 1891.

The principle upon which this pyrometer is constructed is the measurement of a current of electricity produced by heating a couple composed of two wires, one platinum and the other platinum with 10% rhodium—the current produced being measured by a galvanometer.

The composition of the gas which surrounds the couple has no influence on the indications.

When temperatures above 2500° F. are to be studied, the wires must have an isolating support and must be of good length, so that all parts of a furnace can be reached. The wires are supported in an iron tube 1/2 inch interior diameter and held in place by a cylinder of refractory clay having two holes bored through, in which the wires are placed. The shortness of time (five seconds) allows the temperature to be taken without deteriorating the tube.

Tests made by this pyrometer in measuring furnace temperatures under a great variety of conditions show that the readings of the scale uncorrected are always within 45° F. of the correct temperature, and in the majority of industrial measurements this is sufficiently accurate.

**Graduation of Le Chatelier's Pyrometer.**—W. C. Roberts-Austen in his *Researches on the Properties of Alloys*, *Proc. Inst. M. E.*, 1892, says: The electromotive force produced by heating the thermo-junction to any given temperature is measured by the movement of the spot of light on the scale graduated in millimeters. The scale is calibrated by heating the thermo-junction to temperatures which have been carefully determined by the aid of the air-thermometer, and plotting the curve from the data so obtained. Many fusion and boiling-points have been established by concurrent evidence of various kinds, and are now generally accepted. The following table contains certain of these:

Deg. F.	Deg. C.		Deg. F.	Deg. C.	
212	100	Water boils.	1733	945	Silver melts.
618	326	Lead melts.	1859	1015	Potassium sulphate melts.
676	358	Mercury boils.			
779	415	Zinc melts.	1913	1045	Gold melts.
838	448	Sulphur boils.	1929	1054	Copper melts.
1157	625	Aluminum melts.	2732	1500	Palladium melts.
1229	665	Selenium boils.	3227	1775	Platinum melts.

**The Temperatures Developed in Industrial Furnaces.**—M. Le Chatelier states that by means of his pyrometer he has discovered that the temperatures which occur in melting steel and in other industrial operations have been hitherto overestimated. He finds the melting heat of white cast iron 1135° (2075° F.), and that of gray cast iron 1220° (2228° F.). Mild steel melts at 1475° (2687° F.), and hard steel at 1410° (2570° F.). The furnace for hard porcelain at the end of the baking has a heat of 1370° (2498° F.). The heat of a normal incandescent lamp is 1800° (3272° F.), but it may be pushed to beyond 2100° (3812° F.).

Prof. Roberts-Austen (*Recent Advances in Pyrometry*, *Trans. A.I.M.E.*, Chicago Meeting, 1893) gives an excellent description of modern forms of pyrometers. The following are some of his temperature determinations.

#### TEN-TON OPEN-HEARTH FURNACE, WOOLWICH ARSENAL.

	Degrees Centigrade.	Degrees Fahr.
Temperature of steel, 0.3% carbon, pouring into ladle.	1645	2993
Steel, 0.3% carbon, pouring into large mold.	1580	2876
Reheating furnace, interior.	930	1706
Cupola furnace, No. 2 cast iron, pouring into ladle.	1600	2912

The following determinations have been effected by M. Le Chatelier:

BESSEMER PROCESS. SIX-TON CONVERTER. Deg. C. Deg F..

A. Bath of Slag.....	1580	2876
B. Metal in ladle.....	1640	2984
C. Metal in ingot mold.....	1580	2876
D. Ingot in reheating furnace.....	1200	2192
E. Ingot under the hammer.....	1080	1976

OPEN-HEARTH FURNACE (Semi-mild Steel).

A. Fuel gas near gas generator.....	720	1328
B. Fuel gas entering into bottom of regenerator chamber	400	752
C. Fuel gas issuing from regenerator chamber.....	1200	2192
Air issuing from regenerator chamber.....	1000	1832
Chimney gases. Furnace in perfect condition.....	300	590
End of the melting of pig charge.....	1420	2588
Completion of conversion.....	1500	2732
Molten steel. In the ladle—Commencement of casting.	1580	2876
End of casting.....	1490	2714
In the molds.....	1520	2768

For very mild (soft) steel the temperatures are higher by 50° C.

BLAST-FURNACE (Gray-Bessemer Pig).

Opening in face of tuyere.....	1930	3506
Molten metal—Commencement of fusion.....	1400	2552
End, or prior to tapping.....	1570	2858

HOFFMAN RED-BRICK KILN

Burning temperatures.....	1100	2012
---------------------------	------	------

R. Moldenke (*The Foundry*, Nov., 1898) determined with a Le Chatelier pyrometer the melting-point of 42 samples of pig iron of different grades. The range was from 2030° F. for pig containing 3.98% combined carbon to 2280 for pig containing 0.13 combined carbon and 3.43% graphite. The results of the whole series may be expressed within 30° F. by the formula  $\text{Temp.} = 2300^\circ - 70 \times \% \text{ of combined carbon.}$

**Hobson's Hot-blast Pyrometer** consists of a brass chamber having three hollow arms and a handle. The hot blast enters one of the arms and induces a current of atmospheric air to flow into the second arm. The two currents mix in the chamber and flow out through the third arm, in which the temperature of the mixture is taken by a mercury thermometer. The openings in the arms are adjusted so that the proportion of hot blast to the atmospheric air remains the same.

**The Wiborgh Air-pyrometer.** (E. Trotz, *Trans. A.I.M.E.*, 1892.)—The inventor using the expansion-coefficient of air, as determined by Gay-Lussac, Dulong, Rudberg, and Regnault, bases his construction on the following theory: If an air-volume,  $V$ , inclosed in a porcelain globe and connected through a capillary pipe with the outside air, be heated to the temperature  $T$  (which is to be determined) and thereupon the connection be discontinued, and there be then forced into the globe containing  $V$  another volume of air  $V'$  of known temperature  $t$ , which was previously under atmospheric pressure  $H$ , the additional pressure  $h$ , due to the addition of the air-volume  $V'$  to the air-volume  $V$ , can be measured by a manometer. But this pressure is of course a function of the temperature  $T$ . Before the introduction of  $V'$ , we have the two separate air-volumes,  $V$  at the temperature  $T$ , and  $V'$  at the temperature  $t$ , both under the atmospheric pressure  $H$ . After the forcing in of  $V'$  into the globe, we have, on the contrary, only the volume  $V$  of the temperature  $T$ , but under the pressure  $H + h$ .

**Seeger Cones.** (Stowe-Fuller Co., Cleveland, 1914). Seeger Cones were developed in 1886 in Germany, by Dr. Herman A. Seeger. They comprise a series of triangular cones, of pyramidal shape, of differing mineral compositions, each one of which requires a different amount of heat work to soften and deform it. They are used principally in the clay, pottery, and allied industries to determine the proper heat conditions of kilns, furnaces, etc. The difference in softening point between any two adjoining member of the series, is kept as nearly equal as possible, so that the cones form a sort of pyrometric scale. The softening or fusion is not altogether a matter of temperature, the element of time entering in also. A longer exposure at a slightly lower temperature will accomplish the same amount of heat work in clay-working as a shorter exposure at a somewhat higher temperature, pro-

vided it is always above the critical temperature at which chemical reactions take place in the clay. Although the time element must be considered, a melting point in degrees F. has been assigned to each cone number for convenience. For rapid burning, this temperature is fairly accurate, but in commercial clay-burning, the cones melt at lower temperatures than those given in the table. In extremely long firings the difference between the actual and assigned temperatures may be as much as 100° or 150° C. (212° to 297° F.)

Dr. Seger's original series consisted of twenty different mixtures, and covered a relatively narrow range of temperatures. Several other series have since been devised, as follows: Hecht series, used by china and glass decorators, consisting of fusible lead-soda borate glass and kaolin, the glass alone making the softest cone, successive additions of kaolin raising the fusing point. The Cremer series, used for red burning clays and for soft glazes, sewer pipe, drain tiles, roof tiles, etc., consisting of a lime-soda borate glass, oxide of iron, feldspar, carbonate of lime, potters flint and kaolin, it begins with a large amount of glass for the softest cone, and decreasing to almost none at the upper end. The Seger series, used for harder red burning wares of vitrified variety, and for all buff burning and white burning clay wares consisting of potters flint, feldspar, carbonate of lime and feldspar, oxide of iron appearing in the three lowest temperature cones; no glass is used and the proportion of kaolin and flint increases with the fusion temperature. High temperature series, used for testing refractory materials only, consisting except in the two lowest numbers of kaolin potters flint, and oxide of alumina; the highest cone consists of pure oxide of alumina. No temperatures can be assigned to this series, although 1850° C. (3362° F.) has been set as the melting point of No. 36. The table gives the approximate fusion points of the various cones.

#### Fusion Points of Seger Cones.

Symbol or Cone No.	Melting Point		Sym- bol or Cone No.	Melting Point		Sym- bol or Cone No.	Melting Point	
	Deg. C	Deg. F		Deg. C	Deg. F		Deg. C	Deg. F
<b>HECHT SERIES</b>								
022	590	1094	04	1070	1958	13	1390	2534
021	620	1148	03	1090	1994	14	1410	2570
020	650	1202	02	1110	2030	15	1430	2606
019	680	1256	01	1130	2066	16	1450	2642
<b>SEGER SERIES</b>								
018	710	1310	1	1150	2102	17	1470	2678
017	740	1364	2	1170	2138	18	1490	2714
016	770	1418	3	1190	2174	19	1510	2750
015	800	1472	4	1210	2210	20	1530	2786
012 1/2	875	1607	5	1230	2246	<b>HIGH TEMP. SERIES</b>		
<b>CREMER SERIES</b>								
010	950	1742	6	1250	2282	26	Lowest Grade for No. 2 Refractories.	
09	970	1778	7	1270	2318	30	Lowest Grade for No. 1 Refractories.	
08	990	1814	8	1290	2354	32	Good Qual. No. 1 Firebrick.	
07	1010	1850	9	1310	2390	34	Excellent Qual. No. 1 Firebrick.	
06	1030	1886	10	1330	2426	36	Melting point pure Kaolin.	
05	1050	1922	11	1350	2462	38	Melting point good qual. Bauxite.	
			12	1370	2498	42	Melting point pure Alumina.	

The German cones are manufactured by the German Government at the Royal Porcelain Factory, Charlottenburg, and can be obtained in the United States through Eimer and Amend, New York, and other chemical supply houses. In 1896, Prof. Edw. Orton, Jr., of the Ohio State University, Columbus, Ohio, began their manufacture in America. The American cones agree with the German cones in all respects, and have come into general use in America. They are not sold through dealers, but must be obtained direct from the maker.

**Mesuré and Nouel's Pyrometric Telescope.** (H. M. Howe, *E. and M. J.*, June 7, 1890)—Mesuré and Nouel's telescope gives an immediate



determination of the temperature of incandescent bodies, and is therefore better adapted to cases where a great number of observations are to be made, and at short intervals, than Seger's. The little telescope, carried in the pocket or hung from the neck, can be used by foreman or heater at any moment.

It is based on the fact that a plate of quartz, cut at right angles to the axis, rotates the plane of polarization of polarized light to a degree nearly inversely proportional to the square of the length of the waves; and, further, on the fact that while a body at dull redness merely emits red light, as the temperature rises, the orange, yellow, green, and blue waves successively appear.

If, now, such a plate of quartz is placed between two Nicol prisms at right angles, "a ray of monochromatic light which passes the first, or polarizer, and is watched through the second, or analyzer, is not extinguished as it was before interposing the quartz. Part of the light passes the analyzer, and, to again extinguish it, we must turn one of the Nicols a certain angle," depending on the length of the waves of light, and hence on the temperature of the incandescent object which emits this light. Hence the angle through which we must turn the analyzer to extinguish the light is a measure of the temperature of the object observed.

**The Uehling and Steinbart Pyrometer.** (For illustrated description see *Engineering*, Aug. 24, 1894.) — The action of the pyrometer is based on a principle which involves the law of the flow of gas through minute apertures in the following manner: If a closed tube or chamber be supplied with a minute inlet and a minute outlet aperture, and air be caused by a constant suction to flow in through one and out through the other of these apertures, the tension in the chamber between the apertures will vary with the difference of temperature between the inflowing and outflowing air. If the inflowing air be made to vary with the temperature to be measured, and the outflowing air be kept at a certain constant temperature, then the tension in the space or chamber between the two apertures will be an exact measure of the temperature of the inflowing air, and hence of the temperature to be measured.

In operation it is necessary that the air be sucked into it through the first minute aperture at the temperature to be measured, through the second aperture at a lower but constant temperature, and that the suction be of a constant tension. The first aperture is therefore located in the end of a platinum tube in the bulb of a porcelain tube over which the hot blast sweeps, or inserted into the pipe or chamber containing the gas whose temperature is to be ascertained.

The second aperture is located in a coupling, surrounded by boiling water, and the suction is obtained by an aspirator and regulated by a column of water of constant height.

The tension in the chamber between the apertures is indicated by a manometer.

**The Air-thermometer.** (Prof. R. C. Carpenter, *Eng'g News*, Jan. 5, 1893.) — Air is a perfect thermometric substance, and if a given mass of air be considered, the product of its pressure and volume divided by its absolute temperature is in every case constant. If the volume of air remain constant, the temperature will vary with the pressure; if the pressure remain constant, the temperature will vary with the volume. As the former condition is more easily attained, air-thermometers are usually constructed of constant volume, in which case the absolute temperature will vary with the pressure.

If we denote pressures by  $p$  and  $p'$ , and the corresponding absolute temperatures by  $T$  and  $T'$ , we should have

$$p : p' :: T : T' \text{ and } T' = p' \frac{T}{p}.$$

The absolute temperature  $T$  is to be considered in every case 460 higher than the thermometer-reading expressed in Fahrenheit degrees. From the form of the above equation, if the pressure  $p$  corresponding to a known absolute temperature  $T$  be known,  $T'$  can be found. The quotient  $T/p$  is a constant which may be used in all determinations with the instrument. The pressure on the instrument can be expressed in inches of mercury, and is evidently the atmospheric pressure  $b$  as shown by a barometer, plus or minus an additional amount  $h$  shown by a manometer attached to the air-thermometer. That is, in general,  $p = b \pm h$ .

The temperature of  $32^{\circ}$  F. is fixed as the point of melting ice, in which case  $T = 460 + 32 = 492^{\circ}$  F. This temperature can be produced by surrounding the bulb in melting ice and leaving it several minutes, so that the temperature of the confined air shall acquire that of the surrounding ice. When the air is at that temperature, note the reading of the attached manometer  $h$ , and that of a barometer; the sum will be the value of  $p$  corresponding to the absolute temperature of  $492^{\circ}$  F. The constant of the instrument,  $K = 492 \div p$ , once obtained, can be used in all future determinations.

**High Temperatures judged by Color.** — The temperature of a body can be approximately judged by the experienced eye unaided. M. Pouillet in 1836 constructed a table, which has been generally quoted in the text-books, giving the colors and their corresponding temperature, but which is now replaced by the tables of H. M. Howe and of Maunsel White and F. W. Taylor (*Trans. A. S. M. E.*, 1899), which are given below.

Howe.	$^{\circ}$ C.	$^{\circ}$ F.	White and Taylor.	$^{\circ}$ C.	$^{\circ}$ F.
Lowest red visible in dark..	470	878	Dark blood-red, black-red .....	....	990
Lowest red visible in daylight.....	475	887	Dark red, blood-red, low red.....	556	1050
Dull red.....	550 to 625	1022 to 1157	Dark cherry-red.....	635	1175
Full cherry.....	700	1292	Medium cherry-red.....	....	1250
Light red.....	850	1562	Cherry, full red.....	746	1375
Full yellow.....	950 to 1000	1742 to 1832	Light cherry, light red*.	843	1550
Light yellow...	1050	1922	Orange, free scaling heat	899	1650
White.....	1150	2102	Light orange.....	941	1725
			Yellow.....	996	1825
			Light yellow.....	1079	1975
			White.....	1205	2200

\* Heat at which scale forms and adheres on iron and steel, i.e., does not fall away from the piece when allowed to cool in air.

Skilled observers may vary  $100^{\circ}$  F. or more in their estimation of relatively low temperatures by color, and beyond  $2200^{\circ}$  F. it is practically impossible to make estimations with any certainty whatever. (Bulletin No. 2, Bureau of Standards, 1905.)

In confirmation of the above paragraph we have the following, in a booklet published by the Halcomb Steel Co., 1908.

$^{\circ}$ C.	$^{\circ}$ F.	Colors.	$^{\circ}$ C.	$^{\circ}$ F.	Colors.
400	752	Red, visible in the dark.	1000	1832	Bright cherry-red.
474	885	Red, visible in the twilight.	1100	2012	Orange-red.
525	975	Red, visible in the daylight.	1200	2192	Orange-yellow.
			1300	2372	Yellow-white.
581	1077	Red, visible in the sunlight.	1400	2552	White welding heat.
			1500	2732	Brilliant white.
700	1292	Dark red.	1600	2912	Dazzling white (bluish white).
800	1472	Dull cherry-red.			
900	1652	Cherry-red.			

Different substances heated to the same temperature give out the same color tints. Objects which emit the same tint and intensity of light cannot be distinguished from each other, no matter how different their texture, surface, or shape may be. When the temperature at all parts of a furnace at a low yellow heat is the same, different objects inside the furnace (firebrick, sand, platinum, iron) become absolutely invisible. (H. M. Howe.)

A bright bar of iron, slowly heated in contact with air, assumes the following tints at annexed temperatures (Claudel):

	Cent.	Fahr.		Cent.	Fahr.
Yellow at.....	225	437	Indigo at.....	288	550
Orange at.....	243	473	Blue at.....	293	559
Red at.....	265	509	Green at.....	332	630
Violet at.....	277	531	"Oxide-gray"...	400	752

The Halcomb Steel Co. (1908) gives the following heats and temper colors of steel:

Cent. Fahr.	Colors.	Cent. Fahr.	Colors.
221.1	430 Very pale yellow.	265.6	510 Spotted red-brown.
226.7	440 Light yellow.	271.1	520 Brown-purple.
232.2	450 Pale straw-yellow.	276.7	530 Light purple.
237.8	460 Straw-yellow.	282.2	540 Full purple.
243.3	470 Deep straw-yellow.	287.8	550 Dark purple.
248.9	480 Dark yellow.	293.3	560 Full blue.
254.4	490 Yellow-brown.	298.9	570 Dark blue.
260.0	500 Brown-yellow.	315.6	600 Very dark blue.

**BOILING-POINT AT ATMOSPHERIC PRESSURE.**

14.7 lb. per square inch.

Ether, sulphuric.....	100° F.	Saturated brine.....	226° F.
Carbon bisulphide.....	118	Nitric acid.....	248
Chloroform.....	140	Oil of turpentine.....	315
Bromine.....	145	Aniline.....	363
Aqua ammonia, sp.gr. 0.95.	146	Naphthaline.....	428
Wood spirit.....	150	Phosphorus.....	554
Alcohol.....	173	Sulphur.....	800
Benzine.....	176	Sulphuric acid.....	590
Water.....	212	Linseed oil.....	597
Average sea-water.....	213.2	Mercury.....	676

The boiling-points of liquids increase as the pressure increases.

**MELTING-POINTS OF VARIOUS SUBSTANCES.**

The following figures are given by Clark (on the authority of Pouillet, Claudel, and Wilson), except those marked \*, which are given by Prof. Roberts-Austen, and those marked †, which are given by Dr. J. A. Harker. These latter are probably the most reliable figures.

Sulphurous acid.....	- 148° F.	Cadmium.....	442° F.
Carbonic acid.....	- 108	Bismuth.....	504 to 507
Mercury.....	- 39, - 38†	Lead.....	618*, 620†
Bromine.....	+ 9.5	Zinc.....	779*, 786†
Turpentine.....	14	Antimony.....	1150, 1169†
Hyponitric acid.....	16	Aluminium.....	1157*, 1214†
Ice.....	32	Magnesium.....	1200
Nitro-glycerine.....	45	NaCl, common salt.....	1472†
Tallow.....	92	Calcium.....	Full red heat.
Phosphorus.....	112	Bronze.....	1692
Acetic acid.....	113	Silver.....	1733*, 1751†
Stearine.....	109 to 120	Potassium sulphate..	1859*, 1958†
Spermaceti.....	120	Gold.....	1913*, 1947†
Margaric acid....	131 to 140	Copper.....	1929*, 1943†
Potassium.....	136 to 144	Nickel.....	2600†
Wax.....	142 to 154	Cast iron, white.....	1922, 2075†
Stearic acid.....	158	“ gray.....	2012 to 2786, 2228*
Sodium.....	194 to 208	Steel.....	2372 to 2532*
Iodine.....	225	“ hard... ..	2570*; mild, 2687
Sulphur.....	239	Wrought iron.....	2732 to 2912, 2737*
Alloy, 1½ tin, 1 lead	334, 367†	Palladium.....	2732*
Tin.....	446, 449†	Platinum.....	3227*, 3110†

Cobalt and manganese, fusible in highest heat of a forge. Tungsten and chromium, not fusible in forge, but soften and agglomerate. Platinum and iridium, fusible only before the oxyhydrogen blowpipe, or in an electrical furnace. For melting-point of fusible alloys see Alloys. For boiling and freezing points of air and other gases see p. 606.

**Melting Points of Rare Metals.**—H. Von Wartenberg has determined the melting points of some rare metals. The temperature was measured by a Wanner pyrometer. The following melting points were thus obtained:

Vanadium.....	1710° C. = 3110° F.
Rhodium.....	1970° C. = 3578° F.
Iridium.....	2360° C. = 4280° F.
Molybdenum.....	over 2550° C. = 4622° F.
Tungsten.....	2900° C. = 5252° F.

The metals were as pure as possible. It is stated that the vanadium



used was of 97% purity. The results were published in a German periodical.—*Brass World*, June, 1910.

### QUANTITATIVE MEASUREMENT OF HEAT.

**Unit of Heat.**—The British thermal unit, or heat unit (B.T.U.), is the quantity of heat required to raise the temperature of 1 lb. of pure water from 62° to 63° F. (Peabody), or  $\frac{1}{180}$  of the heat required to raise the temperature of 1 lb. of water from 32° to 212° F. (Marks and Davis, see *Steam*, p. 867).

The French thermal unit, or *calorie*, is the quantity of heat required to raise the temperature of 1 kilogram of pure water from 15° to 16° C.

1 French calorie = 3.968 British thermal units; 1 B.T.U. = 0.252 calorie. The "pound calorie" is sometimes used by English writers; it is the quantity of heat required to raise the temperature of 1 lb. of water 1° C. 1 lb. calorie =  $\frac{9}{5}$  B.T.U. = 0.4536 calorie. The heat of combustion of carbon to CO<sub>2</sub> is said to be 8080 calories. This figure is used either for French calories or for pound calories, as it is the number of pounds of water that can be raised 1° C. by the complete combustion of 1 lb. of carbon, or the number of kilograms of water that can be raised 1° C. by the combustion of 1 kilo. of carbon; assuming in each case that all the heat generated is transferred to the water.

**The Mechanical Equivalent of Heat** is the number of foot-pounds of mechanical energy equivalent to one British thermal unit, heat and mechanical energy being mutually convertible. Joule's experiments, 1843-50, gave the figure 772, which is known as Joule's equivalent. More recent experiments by Prof. Rowland (1880) and others give higher figures; 778 is generally accepted, but 777.6 is probably more nearly correct. (Goodenough's "Properties of Steam and Ammonia," 1915.)

1 heat-unit is equivalent to 778 ft.-lbs. of energy. 1 ft.-lb. =  $\frac{1}{778}$  = 0.0012852 heat-unit. 1 horse-power = 33,000 ft.-lbs. per minute = 2545 heat-units per hour = 42.416 + per minute = 0.70694 per second. 1 lb. carbon burned to CO<sub>2</sub> = 14,600 heat-units. 1 lb. C per H.P. per hour =  $2545 \div 14,600 = 17.43\%$  efficiency.

### Heat of Combustion of Various Substances in Oxygen.

	Heat-units.		Authority.
	Cent.	Fahr.	
Hydrogen to liquid water at 0° C..	{ 34,462 33,808 34,342	{ 62,032 60,854 61,816	Favre and Silbermann. Andrews. Thomsen.
"    to steam at 100° C.....	28,732	51,717	Favre and Silbermann. "
Carbon (wood charcoal) to carbonic acid, CO <sub>2</sub> ; ordinary temperatures .....	{ 8,080 7,900 8,137	{ 14,544 14,220 14,647	" Andrews. Berthelot.
Carbon, diamond to CO <sub>2</sub> .....	7,859	14,146	"
"    black diamond to CO <sub>2</sub> ....	7,861	14,150	"
"    graphite to CO <sub>2</sub> .....	7,901	14,222	"
Carbon to carbonic oxide, CO.....	2,473	4,451	Favre and Silbermann. "
Carbonic oxide to CO <sub>2</sub> per unit of CO.....	{ 2,403 2,431 2,385	{ 4,325 4,376 4,293	" Andrews. Thomsen.
CO to CO <sub>2</sub> per unit of C = $2\frac{1}{3} \times 2403$	5,607	10,093	Favre and Silbermann. Thomsen.
Marsh-gas, Methane, CH <sub>4</sub> , to water and CO <sub>2</sub> .....	{ 13,120 13,108 13,063	{ 23,616 23,594 23,513	Thomsen. Andrews. Favre and Silbermann. "
Olefiant gas, Ethylene, C <sub>2</sub> H <sub>4</sub> , to water and CO <sub>2</sub> .....	{ 11,858 11,942 11,957	{ 21,344 21,496 21,523	" Andrews. Thomsen. "
Benzole gas, C <sub>6</sub> H <sub>6</sub> , to water and CO <sub>2</sub>	{ 10,102 9,915	{ 18,184 17,847	" Favre and Silbermann. N. W. Lord.
Sulphur to sulphur dioxide, SO <sub>2</sub> ...	2,250	4,050	

In calculations of the heating value of mixed fuels the value for carbon is commonly taken at 14,600 B.T.U., and that of hydrogen at 62,000. Taking the heating value of C burned to  $\text{CO}_2$  at 14,600, and that of C to CO at 4450, the difference, 10,150 B.T.U., is the heat lost by the imperfect combustion of each lb. of C burned to CO instead of to  $\text{CO}_2$ . If the CO formed by this imperfect combustion is afterwards burned to  $\text{CO}_2$  the lost heat is regained.

In burning 1 pound of hydrogen with 8 pounds of oxygen to form 9 pounds of water, the units of heat evolved are 62,000; but if the resulting product is not cooled to the initial temperature of the gases, part of the heat is rendered latent in the steam. The total heat of 1 lb. of steam at  $212^\circ\text{F}$ . is 1150.0 heat-units above that of water at  $32^\circ$ , and  $9 \times 1150 = 10,350$  heat-units, which deducted from 62,000 gives 51,650 as the heat evolved by the combustion of 1 lb. of hydrogen and 8 lbs. of oxygen at  $32^\circ\text{F}$ . to form steam at  $212^\circ\text{F}$ .

Some writers subtract from the total heating value of hydrogen only the latent heat of the 9 lbs. of steam, or  $9 \times 970.4 = 8734$  B.T.U., leaving as the "low" heating value 53,266 B.T.U.

The use of heating values of hydrogen "burned to steam," in computations relating to combustion of fuel, is inconvenient, since it necessitates a statement of the conditions upon which the figures are based; and it is, moreover, misleading, if not inaccurate, since hydrogen in fuel is not often burned in pure oxygen, but in air; the temperature of the gases before burning is not often the assumed standard temperature, and the products of combustion are not often discharged at  $212^\circ$ . In steam-boiler practice the chimney gases are usually discharged above  $300^\circ$ ; but if economizers are used, and the water supplied to them is cold, the gases may be cooled to below  $212^\circ$ , in which case the steam in the gases is condensed and its latent heat of evaporation is utilized. If there is any need at all of using figures of the "available" heating value of hydrogen, or its heating value when "burned to steam," the fact that the gas is burned in air and not in pure oxygen should be taken into consideration. The resulting figures will then be much lower than those above given, and they will vary with different conditions. (Kent, "Steam Boiler Economy," p. 23.)

Suppose that 1 lb. of H is burned in twice the quantity of air required for complete combustion, or  $2 \times (8\text{ O} + 26.56\text{ N}) = 69.12$  lbs. air supplied at  $62^\circ\text{F}$ ., and that the products of combustion escape at  $562^\circ\text{F}$ . The heat lost in the products of combustion will be

9 lbs. water heated from $62^\circ$ to $212^\circ$ .....	1352 B.T.U.
Latent heat of 9 lbs. $\text{H}_2\text{O}$ at $212^\circ$ , $9 \times 969.7$ .....	8727 "
Superheated steam, 9 lbs. $\times (562^\circ - 212^\circ) \times 0.48$ (sp. ht.)	1512 "
Nitrogen, $26.56 \times (562^\circ - 62^\circ) \times 0.2438$ .....	3238 "
Excess air, $34.56 \times (562^\circ - 62^\circ) \times 0.2375$ .....	4104 "
Total.....	18,933 "

which subtracted from 62,000 gives 43,067 B.T.U. as the net available heating value under the conditions named.

**Heating Value of Compound or Mixed Fuels.** — The heating value of a solid compound or mixed fuel is the sum of its elementary constituents, and is calculated as follows by Dulong's formula:

$$\text{B.T.U.} = \frac{1}{100} \left[ 14,600\text{ C} + 62,000 \left( \text{H} - \frac{\text{O}}{8} \right) + 4500\text{ S} \right];$$

in which C, H, O, and S are respectively the percentages of the several elements. The term  $\text{H} - \frac{1}{8}\text{O}$  is called the "available" or "disposable" hydrogen, or that which is not combined with oxygen in the fuel. For all the common varieties of coal, cannel coal and some lignites excepted, the formula is accurate within the limits of error of chemical analyses and calorimetric determinations.

**Heat Absorbed by Decomposition.** — By the decomposition of a chemical compound as much heat is absorbed or rendered latent as was evolved when the compound was formed. If 1 lb. of carbon is burned to  $\text{CO}_2$ , generating 14,600 B.T.U., and the  $\text{CO}_2$  thus formed is immediately reduced to CO in the presence of glowing carbon, by the reaction  $\text{CO}_2 + \text{C} = 2\text{CO}$ , the result is the same as if the 2 lbs. C had been burned directly to 2 CO, generating  $2 \times 4450 = 8900$  B.T.U. The 2 lbs. C burned to  $\text{CO}_2$

would generate  $2 \times 14,600 = 29,200$  B.T.U., the difference,  $29,200 - 8900 = 20,300$  B.T.U., being absorbed or rendered latent in the 2 CO, or 10,150 B.T.U. for each pound of carbon.

In like manner if 9 lbs. of water be injected into a large bed of glowing coal, it will be decomposed into 1 lb. H and 8 lbs. O. The decomposition will absorb 62,000 B.T.U., cooling the bed of coal this amount, and the same quantity of heat will again be evolved if the H is subsequently burned with a fresh supply of O. The 8 lbs. of O will combine with 6 lbs. C, forming 14 lbs. CO (since CO is composed of 12 parts C to 16 parts O), generating  $6 \times 4450 = 26,700$  B.T.U., and  $6 \times 10,150 = 60,900$  B.T.U. will be latent in this 14 lbs. CO, to be evolved later if it is burned to CO<sub>2</sub> with an additional supply of 8 lbs. O.

### SPECIFIC HEAT.

**Thermal Capacity.**—The thermal capacity of a body between two temperatures  $T_0$  and  $T_1$  is the quantity of heat required to raise the temperature from  $T_0$  to  $T_1$ . The ratio of the heat required to raise the temperature of a certain weight of a given substance one degree to that required to raise the temperature of the same weight of water from 62° to 63° F. is commonly called the *specific heat* of the substance. Some writers object to the term as being an inaccurate use of the words "specific" and "heat." A more correct name would be "coefficient of thermal capacity."

**Determination of Specific Heat.**—*Method by Mixture.*—The body whose specific heat is to be determined is raised to a known temperature, and is then immersed in a mass of liquid of which the weight, specific heat, and temperature are known. When both the body and the liquid have attained the same temperature, this is carefully ascertained.

Now the quantity of heat lost by the body is the same as the quantity of heat absorbed by the liquid.

Let  $c$ ,  $w$ , and  $t$  be the specific heat, weight, and temperature of the hot body, and  $c'$ ,  $w'$ , and  $t'$  of the liquid. Let  $T$  be the temperature the mixture assumes.

Then, by the definition of specific heat,  $c \times w \times (t - T) =$  heat-units lost by the hot body, and  $c' \times w' \times (T - t') =$  heat-units gained by the cold liquid. If there is no heat lost by radiation or conduction, these must be equal, and

$$cw(t - T) = c'w'(T - t') \text{ or } c = \frac{c'w'(T - t')}{w(t - T)}$$

*Electrical Method.* This method is believed to be more accurate in many cases than the method by mixture. It consists in measuring the quantity of current in watts required to heat a unit weight of a substance one degree in one minute, and translating the result into heat-units. 1 Watt = 0.0569 B.T.U. per minute.

### Specific Heats of Various Substances.

The specific heats of substances, as given by different authorities show considerable lack of agreement, especially in the case of gases.

The following tables give the mean specific heats of the substances named according to Regnault. (From Röntgen's Thermodynamics, p. 134.) These specific heats are average values, taken at temperatures which usually come under observation in technical application. The actual specific heats of all substances, in the solid or liquid state, increase slowly as the body expands or as the temperature rises. It is probable that the specific heat of a body when liquid is greater than when solid. For many bodies this has been verified by experiment.

#### SOLIDS.

Antimony.....	0.0508	Steel (soft).....	0.1165
Copper.....	0.0951	Steel (hard).....	0.1175
Gold.....	0.0324	Zinc.....	0.0956
Wrought iron.....	0.1138	Brass.....	0.0939
Glass.....	0.1937	Ice.....	0.5040
Cast iron.....	0.1298	Sulphur.....	0.2026
Lead.....	0.0314	Charcoal.....	0.2410
Platinum.....	0.0324	Alumina.....	0.1970
Silver.....	0.0570	Phosphorus.....	0.1887
Tin.....	0.0562		



LIQUIDS.

Water.....	1.0000	Mercury.....	0.0333
Lead (melted).....	0.0402	Alcohol (absolute).....	0.7000
Sulphur ".....	0.2340	Fusel oil.....	0.5640
Bismuth ".....	0.0308	Benzine.....	0.4500
Tin ".....	0.0637	Ether.....	0.5034
Sulphuric acid.....	0.3350		

GASES.

Constant Pressure.      Constant Volume.

Air.....	0.23751	0.16847
Oxygen.....	0.21751	0.15507
Hydrogen.....	3.40900	2.41226
Nitrogen.....	0.24380	0.17273
Superheated steam*.....	0.4805	0.346
Carbonic acid.....	0.217	0.171
Olefiant gas C <sub>2</sub> H <sub>4</sub> (ethylene), ..	0.404	0.332
Carbonic oxide.....	0.2479	0.1758
Ammonia.....	0.508	0.299
Ether.....	0.4797	0.3411
Alcohol.....	0.4534	0.399
Acetic acid.....	0.4125	.....
Chloroform.....	0.1567	.....

In addition to the above, the following are given by other authorities. (Selected from various sources.)

METALS.

Platinum, 32° to 446° F... (increased .000305 for each 100° F.)	0.0333	Wrought iron (Petit & Dulong).	
Cadmium.....	0.0567	" 32° to 212° ..	0.1098
Brass.....	0.0939	" 32° to 392° ..	0.115
Copper, 32° to 212° F.....	0.094	" 32° to 572° ..	0.1218
" 32° to 572° F.....	0.1013	" 32° to 662° ..	0.1255
Zinc, 32° to 212° F.....	0.0927	Iron at high temperatures.	
" 32° to 572° F.....	0.1015	(Pionchon, <i>Comptes Rendus</i> , 1887.)	
Nickel.....	0.1086	1382° to 1832° F.....	0.213
Aluminum, 0° F. to melting-point (A. E. Hunt).....	0.2185	1749° to 1843° F.....	0.218
		1922° to 2192° F.....	0.199

Dr.-Ing. P. Oberhoffer, in *Zeit. des Vereines Deutscher Ingenieure (Eng. Digest, Sept., 1908)*, describes some experiments on the specific heat of nearly pure iron. The following mean specific heats were obtained:

Temp. F.	500	600	800	1000	1200	1300
Sp. Ht.	0.1228	0.1266	0.1324	0.1388	0.1462	0.1601
Temp. F.	1500	1800	2100	2400	2700	
Sp. Ht.	0.1698	0.1682	0.1667	0.1662	0.1666	

The specific heat increases steadily between 500 and 1200 F. Then it increases rapidly to 1400, after which it remains nearly constant.

OTHER SOLIDS.

Brickwork and masonry, about	0.20	Coal.....	0.20 to 0.241
Marble.....	0.210	Coke.....	0.203
Chalk.....	0.215	Graphite.....	0.202
Quicklime.....	0.217	Sulphate of lime.....	0.197
Magnesian limestone.....	0.217	Magnesia.....	0.222
Silica.....	0.191	Soda.....	0.231
Corundum.....	0.198	Quartz.....	0.188
Stones generally.....	0.2 to 0.22	River sand.....	0.195

WOODS.

Oven dried, 20 varieties, sp. ht. nearly the same for all, average 0.327. (U. S. Forest Service, 1911.)

LIQUIDS.

Alcohol, density 0.793.....	0.622	Olive oil.....	0.310
Sulphuric acid, density 1.87.....	0.335	Benzine.....	0.393
" " 1.30.....	0.661	Turpentine, density 0.872..	0.472
Hydrochloric acid.....	0.600	Bromine.....	1.111

\* See Superheated Steam, page 869.

## GASES.

	At Constant Pressure.	At Constant Volume.
Sulphurous acid.....	0.1553	0.1246
Light carbureted hydrogen, marsh gas (CH <sub>4</sub> ) .	0.5929	0.4683
Blast-furnace gases.....	0.2277	.....

**Specific Heat of Water.** (Peabody's Steam Tables, from Barnes and Regnault.)

°C.	°F.	Sp. Ht.	°C.	°F.	Sp. Ht.	°C.	°F.	Sp. Ht.	°C.	°F.	Sp. Ht.
0	32	1.0094	35	95	0.99735	70	158	1.00150	120	248	1.01620
5	41	1.00530	40	104	0.99735	75	167	1.00275	140	284	1.02230
10	50	1.00230	45	113	0.99760	80	176	1.00415	160	320	1.02850
15	59	1.00030	50	122	0.99800	85	188	1.00557	180	356	1.03475
20	68	0.99895	55	131	0.99850	90	194	1.00705	200	392	1.04100
25	77	0.99806	60	140	0.99940	95	203	1.00855	220	428	1.04760
30	86	0.99759	65	149	1.00040	100	212	1.01010			

**Specific Heat of Salt Solution.** (Schuller.)

Per cent salt in solution....	5	10	15	20	25
Specific heat.....	0.9306	0.8909	0.8606	0.8490	0.8073

**Specific Heat of Air.**—Regnault gives for the mean value at constant pressure

Between - 30° C. and + 10° C.....	0.23771
“ 0° C. “ 100° C.....	0.23741
“ 0° C. “ 200° C.....	0.23751

Hanssen uses 0.1686 for the specific heat of air at constant volume. The value of this constant has never been found to any degree of accuracy by direct experiment. Prof. Wood gives  $0.2375 \div 1.406 = 0.1689$ . The ratio of the specific heat of a fixed gas at constant pressure to the sp. ht. at constant volume is given as follows by different writers (*Eng'g*, July 12, 1889): Regnault, 1.3953; Moll and Beck, 1.4085; Szathmari, 1.4027; J. Macfarlane Gray, 1.4. The first three are obtained from the velocity of sound in air. The fourth is derived from theory. Prof. Wood says: The value of the ratio for air, as found in the days of La Place, was 1.41, and we have  $0.2377 \div 1.41 = 0.1686$ , the value used by Clausius, Hanssen, and many others. But this ratio is not definitely known. Rankine in his later writings used 1.408, and Tait in a recent work gives 1.404, while some experiments give less than 1.4, and others more than 1.41. Prof. Wood uses 1.406.

**Specific Heat of Gases.**—Experiments by Mallard and Le Chatelier indicate a continuous increase in the specific heat at constant volume of steam, CO<sub>2</sub>, and even of the perfect gases, with rise of temperature. The variation is inappreciable at 100° C., but increases rapidly at the high temperatures of the gas-engine cylinder. (Robinson's Gas and Petroleum Engines.)

**Thermal Capacity and Specific Heat of Gases.** (From Damour's "Industrial Furnaces.")—The specific heat of a gas at any temperature is the first derivative of the function expressing the thermal capacity. It is not possible to derive from the specific heat of a gas at a given temperature, or even from the mean specific heat between 0° and 100° C., the thermal capacity at a temperature above 100° C. The specific heats of gases under constant pressure between 0° and 100° C., given by Regnault, are not sufficient to calculate the quantity of heat absorbed by a gas in heating or radiated in cooling, hence all calculations based on these figures are subject to a more or less grave error.

The thermal capacities of a molecular volume (22.32 liters) of gases from absolute 0° (- 273° C.) to a temperature  $T (= 273° + t)$  may be expressed by the formula  $Q = 0.001 aT + 0.000,001 bT^2$ , in which  $a$  is a constant, 6.5, for all gases, and  $b$  has the following values for different gases: O<sub>2</sub>, N<sub>2</sub>, H<sub>2</sub>, CO, 0.6; H<sub>2</sub>O vapor, 2.9; CO<sub>2</sub>, 3.7; CH<sub>4</sub>, 6.0. The tables on page 565 give the thermal capacities of different gases under varying conditions of pressure, temperature and volume.

## SPECIFIC HEATS OF GASES PER KILOGRAM.

Gases.	Under Constant Pressure.	Under Constant Volume.
Oxygen.....	0.213 + 38 × 10 <sup>-6</sup> t	0.150 + 38 × 10 <sup>-6</sup> t
Nitrogen and Carbon Monoxide..	0.243 + 42 × 10 <sup>-6</sup> t	0.171 + 42 × 10 <sup>-6</sup> t
Hydrogen.....	3.400 + 600 × 10 <sup>-6</sup> t	2.400 + 600 × 10 <sup>-6</sup> t
Water Vapor.....	0.447 + 324 × 10 <sup>-6</sup> t	0.335 + 324 × 10 <sup>-6</sup> t
Carbon Dioxide.....	0.193 + 168 × 10 <sup>-6</sup> t	0.150 + 168 × 10 <sup>-6</sup> t
Methane.....	0.608 + 748 × 10 <sup>-6</sup> t	0.491 + 748 × 10 <sup>-6</sup> t

## THERMAL CAPACITIES OF GASES PER KILOGRAM IN CENTIGRADE DEGS.

Gases.	Under Constant Pressure.	Under Constant Volume.
Oxygen.....	0.213 t + 19 × 10 <sup>-6</sup> t <sup>2</sup>	0.150 t + 19 × 10 <sup>-6</sup> t <sup>2</sup>
Nitrogen and Carbon Monoxide..	0.243 t + 21 × 10 <sup>-6</sup> t <sup>2</sup>	0.171 t + 21 × 10 <sup>-6</sup> t <sup>2</sup>
Hydrogen.....	3.400 t + 300 × 10 <sup>-6</sup> t <sup>2</sup>	2.400 t + 300 × 10 <sup>-6</sup> t <sup>2</sup>
Water Vapor.....	0.447 t + 162 × 10 <sup>-6</sup> t <sup>2</sup>	0.335 t + 162 × 10 <sup>-6</sup> t <sup>2</sup>
Carbon Dioxide.....	0.193 t + 84 × 10 <sup>-6</sup> t <sup>2</sup>	0.150 t + 84 × 10 <sup>-6</sup> t <sup>2</sup>
Methane or Marsh Gas.....	0.608 t + 374 × 10 <sup>-6</sup> t <sup>2</sup>	0.491 t + 374 × 10 <sup>-6</sup> t <sup>2</sup>

## THERMAL CAPACITIES OF GASES PER KILOGRAM.

Temperatures.	O <sub>2</sub>	N <sub>2</sub> , CO	H <sub>2</sub>	H <sub>2</sub> O	CO <sub>2</sub>	CH <sub>4</sub>
Degrees Centigrade.	0	0	0	0	0	0
200.....	47.0	50	700	100	43.1	136.6
400.....	88.0	100	1400	203	91.0	303.0
600.....	134.0	154	2150	326	145.0	499.0
800.....	181.0	207	2900	461	208.0	726.0
1000.....	232.0	264	3700	609	277.0	982.0
1200.....	284.0	325	4550	770	354.0	1269.0
1400.....	334.0	383	5350	943	435.0	1584.0
1600.....	391.0	445	6250	1130	523.0	1931.0
1800.....	444.0	508	7100	1330	618.0	2307.0
2000.....	503.0	575	8050	1542	728.0	2712.0
2200.....	558.0	637	8950	1751	840.0	3148.0
2400.....	670.0	708	9900	1985	950.0	3614.0
2600.....	681.0	777	10900	2241	1070.0	4109.0
2800.....	735.0	850	11900	2520	1200.0	4635.0
3000.....	810.0	921	12950	2799	1355.0	5190.0

## EXPANSION BY HEAT.

In the centigrade scale the coefficient of expansion of air per degree is 0.003665 = 1/273; that is, the pressure being constant, the volume of a perfect gas increases 1/273 of its volume at 0° C. for every increase in temperature of 1° C. In Fahrenheit units it increases 1/491.6 = 0.002034 of its volume at 32° F. for every increase of 1° F.

## Expansion of Gases by Heat from 32° to 212° F. (Regnault.)

	Increase in Volume, Pressure Constant. Volume at 32° Fahr. = 1.0, for		Increase in Pressure, Volume Constant. Pressure at 32° Fahr. = 1.0, for	
	100° C.	1° F.	100° C.	1° F.
Hydrogen.....	0.3661	0.002034	0.3667	0.002037
Atmospheric air.....	0.3670	0.002039	0.3665	0.002036
Nitrogen.....	0.3670	0.002039	0.3668	0.002039
Carbon monoxide.....	0.3669	0.002038	0.3667	0.002037
Carbon dioxide.....	0.3710	0.002061	0.3688	0.002039
Sulphur dioxide.....	0.3903	0.002168	0.3845	0.002136

If the volume is kept constant, the pressure varies directly as the absolute temperature.



## Lineal Expansion of Solids at Ordinary Temperatures.

(Mostly British Board of Trade; from Clark.)

	For 1° Fahr. Length = 1.	For 1° Cent. Length = 1.	Expansion from 32° to 212° F.	According to Other Author- ities.
Aluminum (drawn).....	0.00001360	0.00002450	0.002450	.....
Aluminum (cast).....	0.00001234	0.00002221	0.002221	.....
Antimony (cryst.).....	0.00000627	0.00001129	0.001129	0.001083
Brass, cast.....	0.00000957	0.00001722	0.001722	0.001838
Brass, plate.....	0.00001052	0.00001894	0.001894	.....
Brick.....	0.00000306	0.00000550	0.000550	.....
Brick (fire).....	0.00000300	0.00000540	0.000540	.....
Bronze (Copper, 17; Tin, 2 1/2; Zinc, 1).....	0.00000986	0.00001774	0.001774	.....
Bismuth.....	0.00000975	0.00001755	0.001755	0.001392
Cement, Portland (mixed), pure.....	0.00000594	0.00001070	0.001070	.....
Concrete: cement-mortar and pebbles.....	0.00000795	0.00001430	0.001430	.....
Copper.....	0.00000887	0.00001596	0.001596	0.001718
Ebonite.....	0.00004278	0.00007700	0.007700	.....
Glass, English flint.....	0.00000451	0.00000812	0.000812	.....
Glass, thermometer.....	0.00000499	0.00000897	0.000897	.....
Glass, hard.....	0.00000397	0.00000714	0.000714	.....
Granite, gray, dry.....	0.00000438	0.00000789	0.000789	.....
Granite, red, dry.....	0.00000498	0.00000897	0.000897	.....
Gold, pure.....	0.00000786	0.00001415	0.001415	.....
Iridium, pure.....	0.00000356	0.00000641	0.000641	.....
Iron, wrought.....	0.00000648	0.00001166	0.001166	0.001235
Iron, cast.....	0.00000556	0.00001001	0.001001	0.001110
Lead.....	0.00001571	0.00002828	0.002828	.....
Magnesium.....				0.002694
Marbles, various { from.....	0.00000308	0.00000554	0.000554	.....
{ to.....	0.00000786	0.00001415	0.001415	.....
Masonry, brick { from.....	0.00000256	0.00000460	0.000460	.....
{ to.....	0.00000494	0.00000890	0.000890	.....
Mercury (cubic expansion).....	0.00009984	0.0017971	0.017971	0.018018
Nickel.....	0.00000695	0.00001251	0.001251	0.001279
Pewter.....	0.00001129	0.00002033	0.002033	.....
Plaster, white.....	0.00000922	0.00001660	0.001660	.....
Platinum.....	0.00000479	0.00000863	0.000863	.....
Platinum, 85 %, Iridium, 15 %.....	0.00000453	0.00000815	0.000815	0.000884
Porcelain.....	0.00000200	0.00000360	0.000360	.....
Quartz, parallel to maj. axis, 0° to 40° C.....	0.00000434	0.00000781	0.000781	.....
Quartz, perpend. to maj. axis, 0° to 40° C.....	0.00000788	0.00001419	0.001419	.....
Silver, pure.....	0.00001079	0.00001943	0.001943	0.001908
Slate.....	0.00000577	0.00001038	0.001038	.....
Steel, cast.....	0.00000636	0.00001144	0.001144	0.001079
Steel, tempered.....	0.00000689	0.00001240	0.001240	.....
Stone (sandstone), dry.....	0.00000652	0.00001174	0.001174	.....
Stone (sandstone), Rauville.....	0.00000417	0.00000750	0.000750	.....
Tin.....	0.00001163	0.00002094	0.002094	0.001938
Wedgwood ware.....	0.00000489	0.00000881	0.000881	.....
Wood, pine.....	0.00000276	0.00000496	0.000496	.....
Zinc.....	0.00001407	0.00002532	0.002532	0.002942
Zinc, 8, Tin, 1.....	0.00001496	0.00002692	0.002692	.....

Invar (see next page), 0.000,000,374 to 0.000,000,44 for 1° C.

Cubical expansion, or expansion of volume = linear expansion  $\times$  3.

**Expansion of Steel at High Temperatures.** (Charpy and Grenet, *Comptes Rendus*, 1902.) — Coefficients of expansion (for 1° C.) of annealed carbon and nickel steels at temperatures at which there is no transforma-

tion of the steel. The results seem to show that iron and carbide of iron have appreciably the same coefficient of expansion. [See also p. 449.]

Composition of Steels.				Mean Coefficients of Expansion from			Coeffs. between	
C	Mn	Si	P	1.5° to 200°	200° to 500°	500° to 650°		
0.03	0.01	0.03	0.013	11.8 × 10 <sup>-6</sup>	14.3 × 10 <sup>-6</sup>	17.0 × 10 <sup>-6</sup>	24.5 × 10 <sup>-6</sup>	880° & 950°
0.25	0.04	0.05	0.010	11.5	14.5	17.5	23.3	800° & 950°
0.64	0.12	0.14	0.009	12.1	14.1	16.5	23.3	720° & 950°
0.93	0.10	0.05	0.005	11.6	14.9	16.0	27.5	" "
1.23	0.10	0.08	0.005	11.9	14.3	16.5	33.8	" "
1.50	0.04	0.09	0.010	11.5	14.9	16.5	36.7	" "
3.50	0.03	0.07	0.005	11.2	14.2	18.0	33.3	" "

Nickel Steels.			Mean Coefficients of Expansion from				
Ni	C	Mn	15° to 100°	100° to 200°	200° to 400°	400° to 600°	600° to 900°
26.9	0.35	0.30	11.0 × 10 <sup>-6</sup>	18.0 × 10 <sup>-6</sup>	18.7 × 10 <sup>-6</sup>	22.0 × 10 <sup>-6</sup>	23.0 × 10 <sup>-6</sup>
28.9	0.35	0.36	10.0	21.5	19.0	20.0	22.7
30.1	0.35	0.34	9.5	14.0	19.5	19.0	21.3
34.7	0.36	0.36	2.0	2.5	11.75	19.5	20.7
36.1	0.39	0.39	1.5	1.5	11.75	17.0	20.3
32.8	0.29	0.66	8.0	14.0	18.0	21.5	22.3
35.8	0.31	0.69	2.5	2.5	12.5	18.75	19.3
37.4	0.30	0.69	2.5	1.5	8.5	19.75	18.3
25.4	1.01	0.79	12.5	18.5	19.75	21.0	35.0
29.4	0.99	0.89	11.0	12.5	19.0	20.5	31.7
34.5	0.97	0.84	3.0	3.5	13.0	18.75	26.7

**Invar**, an alloy of iron with 36 per cent of nickel, has a smaller coefficient of expansion with the ordinary atmospheric changes of temperature than any other metal or alloy known. This alloy is sold under the name of "Invar," and is used for scientific instruments, pendulums of clocks, steel tape-measures for accurate survey work, etc. The Bureau of Standards found its coefficient of expansion to range from 0.000,000,374 to 0.000,000,44 for 1° C., or about 1/23 of that of steel. For all surveys except in the most precise geodetic work a tape of invar may be used without correction for temperature. (*Eng. News*, Aug. 13, 1908.)

**Platinite**, an alloy of iron with 42 per cent of nickel, has the same coefficient of expansion and contraction at atmospheric temperatures as has glass. It can, therefore, be used for the manufacture of armored glass, that is, a plate of glass into which a network of steel wire has been rolled, and which is used for fire-proofing, etc. It can also be used instead of platinum for the electric connections passing through the glass plugs in the base of incandescent electric lights. (Stoughton's "Metallurgy of Steel.")

**Expansion of Liquids from 32° to 212° F.** — Apparent expansion in glass (Clark). Volume at 212°, volume at 32° being 1:

Water.....	1.0466	Nitric acid.....	1.11
Water saturated with salt.	1.05	Olive and linseed oils.....	1.08
Mercury.....	1.0182	Turpentine and ether.....	1.07
Alcohol.....	1.11	Hydrochloric and sulphuric acids.....	1.06

For water at various temperatures, see Water.

For air at various temperatures, see Air.

**ABSOLUTE TEMPERATURE — ABSOLUTE ZERO.**

The absolute zero of a gas is a theoretical consequence of the law of expansion by heat, assuming that it is possible to continue the cooling of a perfect gas until its volume is diminished to nothing.

The volume of a perfect gas increases  $1/273.1$  of its volume at  $0^\circ\text{C}$ . for every increase of temperature of  $1^\circ\text{C}$ ., and decreases  $1/273.1$  of its volume at  $0^\circ\text{C}$ . for every decrease of temperature of  $1^\circ\text{C}$ . At  $-273.1^\circ\text{C}$ . the volume would then be reduced to nothing. This point,  $-273.1^\circ\text{C}$ . =  $-459.6^\circ\text{F}$ ., or  $491.6^\circ\text{F}$ . below the temperature of melting ice, is called the absolute zero, and absolute temperatures are measured on either the Centigrade or the Fahrenheit scale, from this zero. The freezing-point,  $32^\circ\text{F}$ ., corresponds to  $491.6^\circ\text{F}$ . absolute. If  $p_0$  be the pressure and  $v_0$  the volume of a perfect gas at  $32^\circ\text{F}$ . =  $491.6^\circ$  absolute, =  $T_0$ , and  $p$  the pressure and  $v$  the volume of the same weight of gas at any other absolute temperature  $T$ , then

$$\frac{pv}{p_0v_0} = \frac{T}{T_0} = \frac{t + 459.6}{491.6}; \quad \frac{pv}{T} = \frac{p_0v_0}{T_0} = R.$$

A cubic foot of dry air at  $32^\circ\text{F}$ . at the sea level (barometer = 29.921 in. of mercury) weighs 0.080728 lb. The volume of one pound is  $1/0.080728 = 12.387$  cu. ft. The pressure is 2116.3 lb. per sq. ft.

$$R = \frac{p_0v_0}{T_0} = \frac{2116.3 \times 12.387}{491.6} = \frac{26,214}{491.6} = 53.32$$

### LATENT HEATS OF FUSION AND EVAPORATION.

**Latent Heat** means a quantity of heat which has disappeared, having been employed to produce some change other than elevation of temperature. By exactly reversing that change, the quantity of heat which has disappeared is reproduced. Maxwell defines it as the quantity of heat which must be communicated to a body in a given state in order to convert it into another state without changing its temperature.

**Latent Heat of Fusion.**—When a body passes from the solid to the liquid state, its temperature remains stationary, or nearly stationary, at a certain melting-point during the whole operation of melting; and in order to make that operation go on, a quantity of heat must be transferred to the substance melted, being a certain amount for each unit of weight of the substance. This quantity is called the latent heat of fusion.

When a body passes from the liquid to the solid state, its temperature remains stationary or nearly stationary during the whole operation of freezing; a quantity of heat equal to the latent heat of fusion is produced in the body and rejected into the atmosphere or other surrounding bodies.

The following are examples in British thermal units per pound, as given in Landolt and Bornstein's "Physikalische-Chemische Tabellen" (Berlin, 1894).

Substances.	Latent Heat of Fusion.	Substances.	Latent Heat of Fusion.
Bismuth.....	22.75	Silver.....	37.93
Cast iron, gray...	41.4	Beeswax.....	76.14
Cast iron, white...	59.4	Paraffine.....	63.27
Lead.....	9.66	Spermaceti.....	66.56
Tin.....	25.65	Phosphorus.....	9.06
Zinc.....	50.63	Sulphur.....	16.86

The latent heat of fusion of ice is generally taken at 144 B.T.U. per lb. The U. S. Bureau of Standards (1915) gives it as 79.76  $20^\circ$ -calories per gram = 143.57 B.T.U. per lb.

**Latent Heat of Evaporation.**—When a body passes from the solid or liquid to the gaseous state, its temperature during the operation remains stationary at a certain boiling-point, depending on the pressure of the vapor produced; and in order to make the evaporation go on, a quantity of heat must be transferred to the substance evaporated, whose amount for each unit of weight of the substance evaporated depends on the temperature. That heat does not raise the temperature of the substance, but disappears in causing it to assume the gaseous state, and it is called the latent heat of evaporation.

When a body passes from the gaseous state to the liquid or solid state, its temperature remains stationary, during that operation, at the boiling-point corresponding to the pressure of the vapor: a quantity of heat equal to the latent heat of evaporation at that temperature is produced



in the body; and in order that the operation of condensation may go on, that heat must be transferred from the body condensed to some other body.

The following are examples of the latent heat of evaporation in British thermal units, of one pound of certain substances, when the pressure of the vapor is one atmosphere of 14.7 lbs. on the square inch:

Substance.	Boiling-point under one atm. Fahr.	Latent Heat in British units.
Water.....	212.0	965.7 (Regnault).
Alcohol.....	172.2	364.3 (Andrews).
Ether.....	95.0	162.8 "
Bisulphide of carbon.....	114.8	156.0 "

The latent heat of evaporation of water at a series of boiling-points extending from a few degrees below its freezing-point up to about 375 degrees Fahrenheit has been determined experimentally by M. Regnault. The results of those experiments are represented approximately by the formula, in British thermal units per pound,

$$l \text{ nearly} = 1091.7 - 0.7 (t - 32^\circ) = 965.7 - 0.7 (t - 212^\circ).$$

Henning (*Ann. der Physik*, 1906) gives for  $t$  from  $0^\circ$  to  $100^\circ$  C.

For 1 kg.,  $l = 94.210 (365 - t^\circ \text{C.}) 0.31249$ .

For 1 lb.,  $l = 141.124 (689 - t^\circ \text{F.}) 0.31249$ .

The last formula gives for the latent heat at  $212^\circ \text{F.}$ , 969.7 B.T.U.

**The Total Heat of Evaporation** is the sum of the heat which disappears in evaporating one pound of a given substance at a given temperature (or latent heat of evaporation) and of the heat required to raise its temperature, before evaporation, from some fixed temperature up to the temperature of evaporation. The latter part of the total heat is called the sensible heat.

In the case of water, the experiments of M. Regnault show that the total heat of steam from the temperature of melting ice increases at a uniform rate as the temperature of evaporation rises. The following is the formula in British thermal units per pound:

$$h = 1091.7 + 0.305 (t - 32^\circ).$$

H. N. Davis (*Trans. A. S. M. E.*, 1908) gives, in British units,  $h = 1150 + 0.3745 (t - 212) - 0.000550 (t - 212)^2$ .

For the total heat, latent heat, etc., of steam at different pressures, see table of the Properties of Saturated Steam. For tables of total heat, latent heat, and other properties of steams of ether, alcohol, acetone, chloroform, chloride of carbon, and bisulphide of carbon, see Röntgen's Thermodynamics (Dubois's translation). For ammonia and sulphur dioxide, see Wood's Thermodynamics; also, tables under Refrigerating Machinery, in this book.

**EVAPORATION AND DRYING.**

In evaporation, the formation of vapor takes place on the surface; in boiling, within the liquid: the former is a slow, the latter a quick, method of evaporation.

If we bring an open vessel with water under the receiver of an air-pump and exhaust the air, the water in the vessel will commence to boil, and if we keep up the vacuum the water will actually boil near its freezing-point. The formation of steam in this case is due to the heat which the water takes out of the surroundings.

Steam formed under pressure has the same temperature as the liquid in which it was formed, provided the steam is kept under the same pressure.

By properly cooling the rising steam from boiling water, as in the multiple-effect evaporating systems, we can regulate the pressure so that the water boils at low temperatures.

**Evaporation of Water in Reservoirs.** — Experiments at the Mount Hope Reservoir, Rochester, N. Y., in 1891, gave the following results:

	July.	Aug.	Sept.	Oct.
Mean temperature of air in shade.....	70.5	70.3	68.7	53.3
" " " water in reservoir...	68.2	70.2	66.1	54.4
" humidity of air, per cent.....	67.0	74.6	75.2	74.7
Evaporation in inches during month.....	5.59	4.93	4.05	3.23
Rainfall in inches during month.....	3.44	2.95	1.44	2.16

**Evaporation of Water from Open Channels.**—(Flynn's Irrigation Canals and Flow of Water.)—Experiments from 1881 to 1885 in Tulare County, California, showed an evaporation from a pan in the river equal to an average depth of  $\frac{1}{8}$  in. per day throughout the year.

When the pan was in the air the average evaporation was less than  $\frac{3}{16}$  in. per day. The average for the month of August was  $\frac{1}{3}$  in. per day, and for March and April  $\frac{1}{12}$  in. per day. Experiments in Colorado show that evaporation ranges from 0.088 to 0.16 in. per day during the irrigating season.

In Northern Italy the evaporation was from  $\frac{1}{12}$  to  $\frac{1}{9}$  inch per day while in the south, under the influence of hot winds, it was from  $\frac{1}{6}$  to  $\frac{1}{5}$  inch per day.

In the hot season in Northern India, with a decidedly hot wind blowing, the average evaporation was  $\frac{1}{2}$  inch per day. The evaporation increases with the temperature of the water.

**Evaporation by the Multiple System.**—A multiple effect is a series of evaporating vessels each having a steam chamber, so connected that the heat of the steam or vapor produced in the first vessel heats the second, the vapor or steam produced in the second heats the third, and so on. The vapor from the last vessel is condensed in a condenser. Three vessels are generally used, in which case the apparatus is called a *Triple Effect*. In evaporating in a triple effect the vacuum is graduated so that the liquid is boiled at a constant and low temperature.

A series distilling apparatus of high efficiency is described by W.F. M. Goss in *Trans. A. S. M. E.*, 1903. It has seven chambers in series, and is designed to distill 500 gallons of water per hour with an efficiency of approximately 60 lbs. of water per pound of coal.

Tests of Yaryan six-effect machines have shown as high as 44 lbs. of water evaporated per pound of fuel consumed.—*Mach'y*, April, 1905. A description of a large distilling apparatus, using three 125-H.P. boilers and a Lillie triple effect, with record of tests, is given in *Eng. News*, Mar. 29, 1900, and in *Jour. Am. Soc'y of Naval Engineers*, Feb., 1900.

Tests of heating and evaporating apparatus used in sugar houses, including calandrias, multiple effects, vacuum pans, and condensers, are described by E. W. Kerr in a 178-page pamphlet, Bulletin 149 of the Agricultural Experiment Station of the Louisiana State University, August, 1914.

**Resistance to Boiling.**—**Brine.** (Rankine.)—The presence in a liquid of a substance dissolved in it (as salt in water) resists ebullition, and raises the temperature at which the liquid boils, under a given pressure; but unless the dissolved substance enters into the composition of the vapor, the relation between the temperature and pressure of saturation of the vapor remains unchanged. A resistance to ebullition is also offered by a vessel of a material which attracts the liquid (as when water boils in a glass vessel), and the boiling take place by starts. To avoid the errors which causes of this kind produce in the measurement of boiling-points, it is advisable to place the thermometer, not in the liquid, but in the vapor, which shows the true boiling-point, freed from the disturbing effect of the attractive nature of the vessel. The boiling-point of saturated brine under one atmosphere is 226° F., and that of weaker brine is higher than the boiling-point of pure water by 1.2° F., for each  $\frac{1}{32}$  of salt that the water contains. Average sea-water contains  $\frac{1}{32}$ ; and the brine in marine boilers is not suffered to contain more than from  $\frac{2}{32}$  to  $\frac{3}{32}$ .

**Methods of Evaporation Employed in the Manufacture of Salt.** (F. E. Engelhardt, Chemist Onondaga Salt Springs; Report for 1889.)—  
 1. Solar heat—solar evaporation. 2. Direct fire, applied to the heating surface of the vessels containing brine—kettle and pan methods.  
 3. The steam-grainer system—steam-pans, steam-kettles, etc. 4. Use of steam and a reduction of the atmospheric pressure over the boiling brine—vacuum system.

When a saturated salt solution boils, it is immaterial whether it is done under ordinary atmospheric pressure at 228° F., or under four atmospheres with a temperature of 320° F., or in a vacuum under  $\frac{1}{10}$  atmosphere, the result will always be a fine-grained salt.

The fuel consumption is stated to be as follows: By the kettle method, 40 to 45 bu. of salt evaporated per ton of fuel, anthracite dust burned on perforated grates; evaporation, 5.53 lbs. of water per pound of coal. By

the pan method, 70 to 75 bu. per ton of fuel. By vacuum pans, single effect, 86 bu. per ton of anthracite dust (2000 lbs.). With a double effect nearly double that amount can be produced.

**Solubility of Common Salt in Pure Water. (Andræ.)**

Temp. of brine, F.....	32	50	86	104	140	176
100 parts water dissolve parts..	35.63	35.69	36.03	36.32	37.06	38.00
100 parts brine contain salt ....	26.27	26.30	26.49	26.64	27.04	27.54

According to Poggial, 100 parts of water dissolve at 229.66° F., 40.35 parts of salt, or in per cent of brine, 28.749. Gay-Lussac found that at 229.72° F., 100 parts of pure water would dissolve 40.38 parts of salt, in per cent of brine, 28.764 parts.

The solubility of salt at 229° F. is only 2.5% greater than at 32°. Hence we cannot, as in the case of alum, separate the salt from the water by allowing a saturated solution at the boiling-point to cool to a lower temperature.

**Strength of Salt Brines.** — The following table is condensed from one given in U. S. Mineral Resources for 1888, on the authority of Dr. Engelhardt.

**Relations between Sallinometer Strength, Specific Gravity, Solid Contents, etc., of Brines of Different Strengths.**

Salinometer, degrees.	Baumé, degrees.	Specific gravity.	Per cent of salt.	Weight of a gallon of this brine in pounds.	Pounds of salt in a gallon of brine of 231 cubic inches.	Gallons of brine required for a bushel of salt.	Pounds of water to be evaporated to produce a bushel of salt.	Lbs. of coal required to produce a bushel of salt, 1 lb. coal evaporating 6 lbs. of water.	Bushels of salt that can be made with a ton of coal of 2000 pounds.
1.....	0.26	1.002	0.265	8.347	0.022	2,531	21,076	3,513	0.569
2.....	0.52	1.003	0.530	8.356	0.044	1,264	10,510	1,752	1.141
4.....	1.04	1.007	1.060	8.389	0.088	629.7	5,227	871.2	2.295
6.....	1.56	1.010	1.590	8.414	0.133	418.6	3,466	577.7	3.462
8.....	2.08	1.014	2.120	8.447	0.179	312.7	2,585	430.9	4.641
10.....	2.60	1.017	2.650	8.472	0.224	249.4	2,057	342.9	5.833
12.....	3.12	1.021	3.180	8.506	0.270	207.0	1,705	284.2	7.038
14.....	3.64	1.025	3.710	8.539	0.316	176.8	1,453	242.2	8.256
16.....	4.16	1.028	4.240	8.564	0.364	154.2	1,265	210.8	9.488
18.....	4.68	1.032	4.770	8.597	0.410	136.5	1,118	186.3	10.73
20.....	5.20	1.035	5.300	8.622	0.457	122.5	1,001	176.8	11.99
30.....	7.80	1.054	7.950	8.781	0.698	80.21	648.4	108.1	18.51
40.....	10.40	1.073	10.600	8.939	0.947	59.09	472.3	78.71	25.41
50.....	13.00	1.093	13.250	9.105	1.206	46.41	366.6	61.10	32.73
60.....	15.60	1.114	15.900	9.280	1.475	37.94	296.2	49.36	40.51
70.....	18.20	1.136	18.550	9.464	1.755	31.89	245.9	40.98	48.80
80.....	20.80	1.158	21.200	9.647	2.045	27.38	208.1	34.69	57.65
90.....	23.40	1.182	23.850	9.847	2.348	23.84	178.8	29.80	67.11
100.....	26.00	1.205	26.500	10.039	2.660	21.04	155.3	25.88	77.26

**Solubility of Sulphate of Lime in Pure Water. (Marignac.)**

Temperature F. degrees..	32	64.5	89.6	100.4	105.8	127.4	186.8	212
Parts water to dissolve 1 part gypsum	} 415	386	371	368	370	375	417	452
Parts water to dissolve 1 part anhydrous CaSO <sub>4</sub>								
	525	488	470	466	468	474	528	572

In salt brine sulphate of lime is much more soluble than in pure water. In the evaporation of salt brine the accumulation of sulphate of lime tends



to stop the operation, and it must be removed from the pans to avoid waste of fuel. The average strength of brine in the New York salt districts in 1889 was 69.38 degrees of the salinometer.

**Concentration of Sugar Solutions.\*** (From "Heating and Concentrating Liquids by Steam," by John G. Hudson; *The Engineer*, June 13, 1890.) — In the early stages of the process, when the liquor is of low density, the evaporative duty will be high, say two to three (British) gallons per square foot of heating surface with 10 lbs. steam pressure, but will gradually fall to an almost nominal amount as the final stage is approached. As a generally safe basis for designing, Mr. Hudson takes an evaporation of one gallon per hour for each square foot of gross heating surface, with steam of the pressure of about 10 lbs.

As examples of the evaporative duty of a vacuum pan when performing the earlier stages of concentration, during which all the heating surface can be employed, he gives the following:

**COIL VACUUM PAN.** —  $4\frac{3}{4}$  in. copper coils, 528 square feet of surface; steam in coils, 15 lbs.; temperature in pan,  $141^{\circ}$  to  $148^{\circ}$ ; density of feed,  $25^{\circ}$  Baumé, and concentrated to  $31^{\circ}$  Baumé.

*First Trial.* — Evaporation at the rate of 2000 gallons per hour = 3.8 gallons per square foot; transmission, 376 units per degree of difference of temperature.

*Second Trial.* — Evaporation at the rate of 1503 gallons per hour = 2.8 gallons per square foot; transmission, 265 units per degree.

As regards the total time needed to work up a charge of massecuite from liquor of a given density, the following figures, obtained by plotting the results from a large number of pans, form a guide to practical working. The pans were all of the coil type, some with and some without jackets, the gross heating surface probably averaging, and not greatly differing from, 0.25 square foot per gallon capacity, and the steam pressure 10 lbs. per square inch. Both plantation and refining pans are included, making various grades of sugar:

Density of feed (degs. Baumé).....	10°	15°	20°	25°	30°
Evaporation required per gallon massecuite discharged.....	6.123	3.6	2.26	1.5	.97
Average working hours required per charge .	12.	9.	6.5	5.	4.
Equivalent average evaporation per hour per square foot of gross surface, assuming 0.25 sq. ft. per gallon capacity.....	2.04	1.6	1.39	1.2	0.97
Fastest working hours required per charge .	8.5	5.5	3.8	2.75	2.0
Equivalent average evaporation per hour per square foot.....	2.88	2.6	2.38	2.18	1.9

The quantity of heating steam needed is practically the same in vacuum as in open pans. The advantages proper to the vacuum system are primarily the reduced temperature of boiling, and incidentally the possibility of using heating steam of low pressure.

In a solution of sugar in water, each pound of sugar adds to the volume of the water to the extent of 0.061 gallon at a low density to 0.0638 gallon at high densities.

**A Method of Evaporating by Exhaust Steam** is described by Albert Stearns in *Trans. A. S. M. E.*, vol. viii. A pan  $17' 6'' \times 11' \times 1' 6''$ , fitted with cast-iron condensing pipes of about 250 sq. ft. of surface, evaporated 120 gallons per hour from clear water, condensing only about one-half of the steam supplied by a plain slide-valve engine of  $14'' \times 32''$  cylinder, making 65 revs. per min., cutting off about two-thirds stroke, with steam at 75 lbs. boiler pressure.

It was found that keeping the pan-room warm and letting only sufficient air in to carry the vapor up out of a ventilator adds to its efficiency, as the average temperature of the water in the pan was only about  $165^{\circ}$  F.

Experiments were made with coils of pipe in a small pan, first with no agitator, then with one having straight blades, and lastly with troughed blades; the evaporative results being about the proportions of one, two, and three respectively.

In evaporating liquors whose boiling-point is  $220^{\circ}$  F., or much above that of water, it is found that exhaust steam can do but little more than

\* For other sugar data, see Bagasse as Fuel, under *Fuel*.

bring them up to saturation strength, but on weak liquors, sirups, glues, etc., it should be very useful.

**Drying in Vacuum.**—An apparatus for drying grain and other substances in vacuum is described by Mr. Emil Passburg in *Proc. Inst. Mech. Engrs.*, 1889. The three essential requirements for a successful and economical process of drying are: 1. Cheap evaporation of the moisture; 2. Quick drying at a low temperature; 3. Large capacity of the apparatus.

The removal of the moisture can be effected in either of two ways: either by slow evaporation, or by quick evaporation — that is, by boiling.

*Slow Evaporation.* — The principal idea carried into practice in machines acting by slow evaporation is to bring the wet substance repeatedly into contact with the inner surfaces of the apparatus, which are heated by steam, while at the same time a current of hot air is also passing through the substances for carrying off the moisture. This method requires much heat, because the hot-air current has to move at a considerable speed in order to shorten the drying process as much as possible; consequently a great quantity of heated air passes through and escapes unused. As a carrier of moisture hot air cannot in practice be charged beyond half its full saturation; and it is in fact considered a satisfactory result if even this proportion be attained. A great amount of heat is here produced which is not used; while, with scarcely half the cost for fuel, a much quicker removal of the water is obtained by heating it to the boiling-point.

*Quick Evaporation by Boiling.* — This does not take place until the water is brought up to the boiling-point and kept there, namely, 212° F., under atmospheric pressure. The vapor generated then escapes freely. Liquids are easily evaporated in this way, because by their motion consequent on boiling the heat is continuously conveyed from the heating surfaces through the liquid, but it is different with solid substances, and many more difficulties have to be overcome, because convection of the heat ceases entirely in solids. The substance remains motionless, and consequently a much greater quantity of heat is required than with liquids for obtaining the same results.

*Evaporation in Vacuum.* — All the foregoing disadvantages are avoided if the boiling-point of water is lowered, that is, if the evaporation is carried out under vacuum.

This plan has been successfully applied in Mr. Passburg's vacuum drying apparatus, which is designed to evaporate large quantities of water contained in solid substances.

The drying apparatus consists of a top horizontal cylinder, surmounted by a charging vessel at one end, and a bottom horizontal cylinder with a discharging vessel beneath it at the same end. Both cylinders are incased in steam-jackets heated by exhaust steam. In the top cylinder works a revolving cast-iron screw with hollow blades, which is also heated by exhaust steam. The bottom cylinder contains a revolving drum of tubes, consisting of one large central tube surrounded by 24 smaller ones, all fixed in tube-plates at both ends; this drum is heated by live steam direct from the boiler. The substance to be dried is fed into the charging vessel through two manholes, and is carried along the top cylinder by the screw creeper to the back end, where it drops through a valve into the bottom cylinder, in which it is lifted by blades attached to the drum and travels forward in the reverse direction; from the front end of the bottom cylinder it falls into a discharging vessel through another valve, having by this time become dried. The vapor arising during the process is carried off by an air-pump, through a dome and air-valve on the top of the upper cylinder, and also through a throttle-valve on the top of the lower cylinder; both of these valves are supplied with strainers.

As soon as the discharging vessel is filled with dried material the valve connecting it with the bottom cylinder is shut, and the dried charge taken out without impairing the vacuum in the apparatus. When the charging vessel requires replenishing, the intermediate valve between the two cylinders is shut, and the charging vessel filled with a fresh supply of wet material; the vacuum still remains unimpaired in the bottom cylinder, and has to be restored only in the top cylinder after the charging vessel has been closed again.

In this vacuum the boiling-point of the water contained in the wet material is brought down as low as 110° F. The difference between this tem-

perature and that of the heating surfaces is amply sufficient for obtaining good results from the employment of exhaust steam for heating all the surfaces except the revolving drum of tubes. The water contained in the solid substance to be dried evaporates as soon as the latter is heated to about 110° F., and as long as there is any moisture to be removed the solid substance is not heated above this temperature.

Wet grains from a brewery or distillery, containing from 75% to 78% of water, have by this drying process been converted from a worthless incumbrance into a valuable food-stuff. The water is removed by evaporation only, no previous mechanical pressing being resorted to.

At Guinness's brewery in Dublin two of these machines are employed. In each of these the top cylinder is 20 ft. 4 in. long and 2 ft. 8 in. diam., and the screw working inside it makes 7 revs. per min.; the bottom cylinder is 19 ft. 2 in. long and 5 ft. 4 in. diam., and the drum of the tubes inside it makes 5 revs. per min. The drying surfaces of the two cylinders amount together to a total area of about 1000 sq. ft., of which about 40% is heated by exhaust steam direct from the boiler. There is only one air-pump, which is made large enough for three machines; it is horizontal, and has only one air-cylinder, which is double-acting, 17<sup>3</sup>/<sub>4</sub> in. diam. and 17<sup>3</sup>/<sub>4</sub> in. stroke; and it is driven at about 45 revs. per min. As the result of about eight months' experience, the two machines have been drying the wet grains from about 500 cwt. of malt per day of 24 hours.

Roughly speaking, 3 cwt. of malt gave 4 cwt. of wet grains, and the latter yield 1 cwt. of dried grains; 500 cwt. of malt will therefore yield about 670 cwt. of wet grains, or 335 cwt. per machine. The quantity of water to be evaporated from the wet grains is from 75% to 78% of their total weight, or, say, about 512 cwt. altogether, being 256 cwt. per machine.

### Driers and Drying.

(Contributed by W. B. Ruggles, 1909.)

Materials of different physical and chemical properties require different types of drying apparatus. It is therefore necessary to classify materials into groups, as below, and design different machines for each group.

**Group A:** Materials which may be heated to a high temperature and are not injured by being in contact with products of combustion. These include cement rock, sand, gravel, granulated slag, clay, marl, chalk, ore, graphite, asbestos, phosphate rock, slacked lime, etc.

The most simple machine for drying these materials is a single revolving shell with lifting flights on the inside, the shell resting on bearing wheels and having a furnace at one end and a stack or fan at the other. The advantage of this style of machine is its low cost of installation and the small number of parts. The disadvantages are great cost of repairs and excessive fuel consumption, due to radiation and high temperature of the stack gases. If the material is fed from the stack and towards the furnace end, the shell near the furnace gets red-hot, causing excessive radiation and frequent repairs. Should the feed be reversed the exhaust temperature must be kept above 212° F., or recondensation will take place, wetting the material.

In order to economize fuel the shell is sometimes supported at the ends and brickwork is erected around the shell, the hot gases passing under the shell and back through it. Although this method is more economical in the use of fuel, the cost of installation and the cost of repairs are greater.

**Group B:** Materials such as will not be injured by the products of combustion but cannot be raised to a high temperature on account of driving off water of crystallization, breaking up chemical combinations, or on account of danger from ignition. Included in these are gypsum, fluor-spar, iron pyrites, coal, coke, lignite, sawdust, leather scraps, cork chips, tobacco stems, fish scraps, tankage, peat, etc. Some of these materials may be dried in a single-shell drier and some in a bricked-in machine, but none of them in a satisfactory way on account of the difficulty of regulating the temperature and, in some cases, the danger of explosion of dust.

**Group C:** Materials which are not injured by a high temperature but which cannot be allowed to come into contact with products of combus-



tion. These are kaolin, ocher and other pigments, fuller's earth, which is to be used in filtering vegetable or animal oils, whitening and similar earthy materials, a large proportion of which would be lost as dust in direct-heat drying. These may be dried by passing through a single-shell drier incased in brickwork and allowing heat to come into contact with the shell only, but this is an uneconomical machine to operate, due to the high temperature of the escaping gases.

Group D: Organic materials which are used for food either by man or the lower animals, such as grain which has been wet, cotton seed, starch feed, corn germs, brewers' grains, and breakfast foods, which must be dried after cooking. These, of course, cannot be brought into contact with furnace gases and must be kept at a low temperature. For these materials a drier using either exhaust or live steam is the only practical one. This is generally a revolving shell in which are arranged steam pipes. Care should be exercised in selecting a steam drier which has perfect and automatic drainage of the pipes. The condensed steam always amounts to more than the water evaporated from the material.

Group E: Materials which are composed wholly or contain a large proportion of soluble salts, such as nitrate of soda, nitrate of potash, carbonates of soda or potash, chlorates of soda or potash, etc. These in drying form a hard scale which adheres to the shell, and a rotary drier cannot be profitably used on account of frequent stops for cleaning. The only practical machine for such materials is a semicircular cast-iron trough having a shaft through the center carrying paddles that constantly stir up the material and feed it through the drier. This machine has brick side walls and an exterior furnace; the heat from the furnace passing under the shell and back through the drying material or out through a stack or fan without passing through the material, as may be desired. Should the material also require a low temperature, the same type of drier can be used by substituting steam-jacketed steel sections instead of cast iron.

The efficiency of a drier is the ratio of the theoretical heat required to do the drying to the total heat supplied. The greatest loss is the heat carried out by the exhaust or waste gases; this may be as great as 40% of the total heat from the fuel, or with a properly designed drier may be as small as 8%. The radiation from the shell or walls may be as high as 25% or as low as 4%. The heat carried away by the dried material may amount under conditions of careless operation to as much as 25% or may be as low as nothing.

A properly designed drier of the direct-heat type for either group "A" or "B" will give an efficiency of from 75% to 85%; a bricked-in return-draught single-shell drier, from 60% to 70%; and a single-shell straight-draught dryer, from 45% to 55%. A properly designed indirect-heat drier for group "C" will give an efficiency of 50% to 60%, and a poorly designed one may not give more than 30%. The best designed steam drier for group "D" in which the losses in the boiler producing the steam must be considered, will not often give an efficiency of more than 42%; and, while a poorly designed one may have an equal efficiency, its capacity may be not more than one-half of a good drier of equal size. The drier described for group "E" will not give an efficiency of more than 55%.

PERFORMANCE OF A STEAM DRIER.

Material: Starch feed. Moisture, initial 39.8%, final 0.22%.  
 Dried material per hour, 831 lbs. Water evaporated per hour, 548 lbs.  
 Steam consumed per hour, 793 lbs. Water evaporated per pound steam, 0.691 lb. Temperature of material, moist, 58°, dry, 212°. Steam pressure, 98 lbs. gauge.

Total heat to evaporate 548 lbs. water at 58° into steam,  
 $548 \times (154.2 + 969.7) = 615,897 \text{ B.T.U.}$

Heat supplied by 793 lbs. steam condensed to water at 212°,  
 $793 \times (1188.2 - 180.3) = 799,265 \text{ B.T.U.}$

Heat used to evaporate water,  
 $(615,897 \div 799,265) = 77.1\%$

Heat used to raise temperature of material,  
 $(831 \times 154 \times 0.492) = 62,963 = 7.9\%$

Loss by radiation . . . 100 - (77.1 + 7.9) = 15%

Total efficiency . . . . . 85.0%

## Performance of Different Types of Driers.

(W. B. Ruggles.)

Type of drier .....	Double shell; direct heat.	Indirect heat; 705 sq. ft.	Single shell, bricked in; direct heat.	Single shell; direct heat.	Stationary, with paddles; direct heat.
Material.....	Sand.	Coal.	Cement slurry.	Lime- stone.	Nitrate of soda.
Moisture, initial, per cent.....	4.58	10.2	61.2	3.6	7.2
Moisture, final, per cent.....	0	0	40.7	0.5	0.3
Calorific value of fuel, B.T.U.....	12100	12290	13200	13180	13600
Fuel consumed per hour, lbs.....	398	213.6	667	460	87
Water evaporated per hour, lbs..	2196	924.2	4057	1325	349
Water evap. per pound fuel, lbs..	5.3	4.3	6.1	2.3	4.0
Material dried per hour, lbs.....	36460	8300	7680	41400	4581
Fuel per ton dried material, lbs. .	21.8	51.3	17.3	22.2	38.0
Heat lost in exhaust air, per cent	11.3	42.8	38.4	38.2	40.7
Heat lost by radiation, etc., per cent.....	7.6	7.7	12.5	15.6	13.8
Heat used to evaporate water, per cent.....	52.5	39.4	52.0	24.4	33.1
Heat used to raise temperature of material, per cent.....	28.6	10.1	7.1	21.8	12.4
Total efficiency, per cent.....	81.1	49.5	59.1	46.2	45.5

## WATER EVAPORATED AND HEAT REQUIRED FOR DRYING.

M = percentage of moisture in material to be dried.

Q = lbs. water evaporated per ton (2000 lbs.) of dry material.

H = British thermal units required for drying, per ton of dry material.

M	Q	H	M	Q	H	M	Q	H
1	20.2	85,624	14	325.6	424,884	35	1,077	1,269,240
2	40.8	108,696	15	352.9	458,248	40	1,333	1,555,960
3	61.9	130,424	16	381.0	489,720	45	1,636	1,895,320
4	83.3	156,296	17	409.6	521,752	50	2,000	2,303,000
5	105.3	180,936	18	439.0	554,680	55	2,444	2,800,280
6	127.7	206,024	19	469.1	588,392	60	3,000	3,423,000
7	150.5	231,560	20	500.0	623,000	65	3,714	4,222,680
8	173.9	257,768	21	531.6	658,392	70	4,667	5,290,040
9	197.8	284,536	22	564.1	694,792	75	6,000	6,783,000
10	222.2	311,864	23	597.4	732,088	80	8,000	9,023,000
11	247.2	339,864	24	631.6	770,392	85	11,333	12,755,960
12	272.7	368,424	25	666.7	809,704	90	18,000	20,223,000
13	298.9	397,768	30	857.0	1,022,840	95	38,000	42,623,000

$$\text{Formulæ: } Q = \frac{2000 M}{100 - M}; H = 1120 Q + 63,000.$$

The value of H is found on the assumption that the moisture is heated from 62° to 212° and evaporated at that temperature, and that the specific heat of the material is 0.21. [2000 × (212 - 62) × 0.21] = 63,000.

**Calculations for Design of Drying Apparatus.** — A most efficient system of drying of moist materials consists in a continuous circulation of a volume of warm dry air over or through the moist material, then passing the air charged with moisture over the cold surfaces of condenser coils to remove the moisture, then heating the same air by steam-heating coils or other means, and again passing it over the material. In the design of apparatus to work on this system it is necessary to know the amount of moisture to be removed in a given time, and to calculate the volume of air that will carry that moisture at the temperature at which it leaves the material, making allowance for the fact that the moist, warm air on leaving

the material may not be fully saturated, and for the fact that the cooled air is nearly or fully saturated at the temperature at which it leaves the cooling coils. A paper by Wm. M. Grosvenor, read before the Am. Inst. of Chemical Engineers (*Heating and Ventilating Mag.*, May, 1909) contains a "humidity table" and a "humidity chart" which greatly facilitate the calculations required. The table is given in a condensed form below. It is based on the following data: Density of air + 0.04% CO<sub>2</sub> =

$$0.001293052$$

(in Kg. per cu. m.). Density of water vapor =  $1 + 0.00367 \times \text{Temp. C.}$   
 =  $0.62186 \times \text{density of air.}$  Density at partial pressure  $\div$  density at 760 m.m. = partial pressure  $\div$  760 m.m. Specific heat of water vapor = 0.475; sp. ht. of air = 0.2373. Kg. per cu. meter  $\times 0.062428$  = lbs. per cu. ft. The results given in the table agree within 1/4% with the figures of the U. S. Weather Bureau. (Compare also the tables of H. M. Prevost Murphy, given under "Air," page 586.) The term "humid heat" in the heading of the table is defined as the B.T.U. required to raise 1° F. one pound of air plus the vapor it may carry when saturated at the given temperature and pressure; and "humid volume" is the volume of one pound of air when saturated at the given temperature and pressure.

Humidity Table.

Temp. F.	Vapor Tension, Millimeters of Mercury.	Lbs. Water Vapor per lb. Air.	Humid Heat, B.T.U.	Humid Volume cu. ft.	Density, lbs. per cu. ft. at 760 Millimeters.		Volume in cu. ft. per lb. of	
					Dry Air.	Sat'd Mix.	Dry Air.	Sat'd Mix.
32	4.569	0.003761	0.2391	12.462	0.080726	0.080556	12.388	12.414
35	5.152	.0042435	.2393	12.549	.080231	.080085	12.464	12.496
40	6.264	.0050463	.2398	12.695	.079420	.079181	12.590	12.629
45	7.582	.0062670	.2403	12.843	.078641	.078348	12.718	12.763
50	9.140	.0075697	.2409	12.999	.077867	.077511	12.842	12.901
55	10.980	.0091163	.2416	13.159	.077109	.076685	12.968	13.041
60	13.138	.010939	.2425	13.326	.076363	.075865	13.095	13.180
65	15.660	.013081	.2435	13.501	.075635	.075039	13.222	13.325
70	18.595	.015597	.2447	13.683	.074921	.074219	13.348	13.471
75	22.008	.018545	.2461	13.876	.074218	.073471	13.474	13.624
80	25.965	.021998	.2478	14.081	.073531	.072644	13.600	13.777
85	30.573	.026026	.2497	14.301	.072852	.071744	13.726	13.938
90	35.774	.030718	.2519	14.539	.072189	.070894	13.852	14.106
95	41.784	.036174	.2545	14.793	.071535	.070051	13.979	14.275
100	48.679	.042116	.2575	15.071	.070894	.069179	14.106	14.455
105	56.534	.049973	.2610	15.376	.070264	.068288	14.232	14.643
110	65.459	.058613	.2651	15.711	.069647	.067383	14.358	14.840
115	75.591	.068662	.2699	16.084	.069040	.066447	14.484	15.050
120	87.010	.080402	.2755	16.499	.068443	.065477	14.611	15.272
125	99.024	.094147	.2820	16.968	.067857	.064480	14.736	15.509
130	114.437	.11022	.2896	17.499	.067380	.063449	14.863	15.761
135	130.702	.12927	.2987	18.103	.066713	.062374	14.989	16.032
140	148.885	.15150	.3093	18.800	.066156	.061255	15.116	16.325
145	169.227	.17816	.3219	19.609	.065601	.060104	15.242	16.643
150	191.860	.21005	.3371	20.559	.065154	.058865	15.368	16.993
155	216.983	.24534	.3553	21.687	.064539	.057570	15.494	17.370
160	244.803	.29553	.3776	23.045	.064016	.056218	15.621	17.788
165	275.592	.35286	.4054	24.708	.063502	.054795	15.748	18.250
170	309.593	.42756	.4405	26.790	.062997	.053305	15.874	18.761
175	347.015	.52285	.4856	29.454	.062500	.051708	16.000	19.339
180	388.121	.64942	.5458	32.967	.062015	.050035	16.126	19.987
185	433.194	.82430	.6288	37.796	.061529	.048265	16.253	20.719
190	482.668	1.00805	.7519	44.918	.061053	.046391	16.379	21.557
195	536.744	1.4994	.9494	56.302	.060588	.044405	16.505	22.521
200	595.771	2.2680	1.3147	77.304	.060127	.042308	16.631	23.638
205	660.116	4.2272	2.1562	131.028	.059674	.040075	16.758	24.954
210	730.267	15.8174	15.9148	562.054	.059228	.037323	16.884	26.796



## RADIATION OF HEAT.

Radiation of heat takes place between bodies at all distances apart, and follows the laws for the radiation of light.

The heat rays proceed in straight lines, and the intensity of the rays radiated from any one source varies inversely as the square of their distance from the source.

This statement has been erroneously interpreted by some writers, who have assumed from it that a boiler placed two feet above a fire would receive by radiation only one-fourth as much heat as if it were only one foot above. In the case of boiler furnaces the side walls reflect those rays that are received at an angle,— following the law of optics, that the angle of incidence is equal to the angle of reflection,— with the result that the intensity of heat two feet above the fire is practically the same as at one foot above, instead of only one-fourth as much.

The rate at which a hotter body radiates heat, and a colder body absorbs heat, depends upon the state of the surfaces of the bodies as well as on their temperatures. The rate of radiation and of absorption are increased by darkness and roughness of the surfaces of the bodies, and diminished by smoothness and polish. For this reason the covering of steam pipes and boilers should be smooth and of a light color: uncovered pipes and steam-cylinder covers should be polished.

The quantity of heat radiated by a body is also a measure of its heat-absorbing power under the same circumstances. When a polished body is struck by a ray of heat, it absorbs part of the heat and reflects the rest. The reflecting power of a body is therefore the complement of its absorbing power, which latter is the same as its radiating power.

The relative radiating and reflecting power of different bodies has been determined by experiment, as shown in the table below, but as far as quantities of heat are concerned, says Prof. Trowbridge (Johnson's Cyclopædia, art. Heat), it is doubtful whether anything further than the said relative determinations can, in the present state of our knowledge, be depended upon, the actual or absolute quantities for different temperatures being still uncertain. The authorities do not even agree on the relative radiating powers. Thus, Leslie gives for tin plate, gold, silver, and copper the figure 12, which differs considerably from the figures in the table below, given by Clark, stated to be on the authority of Leslie, De La Provostaye and Desains, and Melloni.

## Relative Radiating and Reflecting Power of Different Substances.

	Radiating or Absorbing Power.	Reflecting Power.		Radiating or Absorbing Power.	Reflecting Power.
Lampblack.....	100	0	Zinc, polished.....	19	81
Water.....	100	0	Steel, polished.....	17	83
Carbonate of lead...	100	0	Platinum, polished.	24	76
Writing-paper.....	98	2	Platinum in sheet..	17	83
Ivory, jet, marble...	93 to 98	7 to 2	Tin.....	15	85
Ordinary glass.....	90	10	Brass, cast, dead polished.....	11	89
Ice.....	85	15	Brass, bright pol- ished.....	7	93
Gum lac.....	72	28	Copper, varnished..	14	86
Silver-leaf on glass..	27	73	Copper, hammered..	7	93
Cast iron, bright pol- ished.....	25	75	Gold, plated.....	5	95
Mercury, about.....	23	77	Gold on polished steel.....	3	97
Wrought iron, pol- ished.....	23	77	Silver, polished bright.....	3	97

Experiments of Dr. A.M. Mayer give the following: The relative radiations from a cube of cast iron, having faces rough, as from the foundry,

planed, "drawfiled," and polished, and from the same surfaces oiled, are as below (Prof. Thurston, in *Trans. A. S. M. E.*, vol. xvi):

	Rough.	Planed.	Drawfiled.	Polished.
Surface oiled.....	100	60	49	45
Surface dry.....	100	32	20	18

It here appears that the oiling of smoothly polished castings, as of cylinder-heads of steam-engines, more than doubles the loss of heat by radiation, while it does not seriously affect rough castings.

**"Black Body" Radiation. Stefan and Boltzman's Law.** (*Eng'g*, March 1, 1907.) — Kirchhoff defined a black body as one that would absorb all radiations falling on it, and would neither reflect nor transmit any. The radiation from such a body is a function of the temperature alone, and is identical with the radiation inside an inclosure all parts of which have the same temperature. By heating the walls of an inclosure as uniformly as possible, and observing the radiation through a very small opening, a practical realization of a black body is obtained. Stefan and Boltzman's law is: The energy radiated by a black body is proportional to the fourth power of the absolute temperature, or  $E = K (T^4 - T_0^4)$ , where  $E$  = total energy radiated by the body at  $T$  to the body at  $T_0$ , and  $K$  is a constant. The total radiation from other than black bodies increases more rapidly than the fourth power of the absolute temperature, so that as the temperature is raised the radiation of all bodies approaches that of the black body. A confirmation of the Stefan and Boltzman law is given in the results of experiments by Lummer and Kurlbaum, as below ( $T_0 = 290$  degrees C., abs. in all cases).

	$T = 492.$	$654.$	$795.$	$1108.$	$1481.$	$1761.$
$\frac{E}{T^4 - T_0^4}$ { Black body .....	109.1	108.4	109.9	109.0	110.7	.....
{ Polished platinum..	4.28	6.56	8.14	12.18	16.69	19.64
{ Iron oxide.....	33.1	33.1	36.6	46.9	65.3	.....

The Stefan-Boltzman law as applied to radiation from a given body may be written  $W = 5.7 e [(0.001T)^4 - (0.001 T_e)^4]$ ;  $W$  = energy in watts radiated per square centimeter of surface,  $T$  = temperature of the hot body,  $T_e$  = temperature of the surrounding space,  $e$  = relative emissivity, a characteristic of the radiating body, always less than unity. For clean polished metal surfaces  $e$  ranges from 0.02 to 0.20; for non-metallic surfaces, from about 0.3 to about 0.9.

**CONDUCTION AND CONVECTION OF HEAT.**

**Conduction** is the transfer of heat between two bodies or parts of a body which touch each other. Internal conduction takes place between the parts of one continuous body, and external conduction through the surface of contact of a pair of distinct bodies.

The rate at which conduction, whether internal or external, goes on, being proportional to the area of the section or surface through which it takes place, may be expressed in thermal units per square foot of area per hour.

**Internal Conduction** varies with the *heat conductivity*, which depends upon the nature of the substance, and is directly proportional to the difference between the temperatures of the two faces of a layer, and inversely as its thickness. The reciprocal of the conductivity is called the *internal thermal resistance* of the substance. If  $r$  represents this resistance,  $x$  the thickness of the layer in inches,  $T'$  and  $T$  the temperatures on the two faces, and  $q$  the quantity in thermal units transmitted per hour per square foot of area,  $q = \frac{T' - T}{rx}$ . (Rankine.)

Péclet gives the following values of  $r$ :

Gold, platinum, silver .....	0.0016	Lead.....	0.0090
Copper.....	0.0018	Marble.....	0.0716
Iron.....	0.0043	Brick.....	0.1500
Zinc.....	0.0045		

## Relative Heat-conducting Power of Metals.

Metals.	*C.&J.	†W.&F.	Metals.	*C.&J.	†W.&F.
Silver.....	1000	1000	Cadmium.....	577	...
Gold.....	981	532	Wrought iron.....	436	119
Gold, with 1% of silver.	840	...	Tin.....	422	145
Copper, rolled.....	845	736	Steel.....	397	116
Copper, cast.....	811	...	Platinum.....	380	84
Mercury.....	677	...	Sodium.....	365	...
Mercury, with 1.25% of tin.....	412	...	Cast iron.....	359	...
Aluminum.....	665	...	Lead.....	287	85
Zinc:			Antimony:		
cast vertically....	628	...	cast horizontally..	215	...
cast horizontally...	608	...	cast vertically....	192	...
rolled.....	641	...	Bismuth.....	61	18

\* Calvert &amp; Johnson.

† Weidemann &amp; Franz.

## INFLUENCE OF A NON-METALLIC SUBSTANCE IN COMBINATION ON THE CONDUCTING POWER OF A METAL.

Influence of carbon on iron:		Cast copper.....	811
Wrought iron.....	436	Copper with 1% of arsenic....	570
Steel.....	397	" with 0.5% of arsenic..	669
Cast iron.....	359	" with 0.25% of arsenic.	771

The Rate of External Conduction through the bounding surface between a solid body and a fluid is approximately proportional to the difference of temperature, when that is small; but when that difference is considerable, the rate of conduction increases faster than the simple ratio of that difference. (Rankine.)

If  $r$ , as before, is the coefficient of internal thermal resistance,  $e$  and  $e'$  the coefficient of external resistance of the two surfaces,  $x$  the thickness of the plate, and  $T'$  and  $T$  the temperatures of the two fluids in contact with the two surfaces, the rate of conduction is  $q = \frac{T' - T}{e + e' + rx}$ . Accord-

ing to Péclet,  $e + e' = \frac{1}{A [1 + B (T' - T)]}$ , in which the constants  $A$  and  $B$  have the following values:

$B$ for polished metallic surfaces.....	0.0028
$B$ for rough metallic surfaces and for non-metallic surfaces..	0.0037
$A$ for polished metals, about.....	0.90
$A$ for glassy and varnished surfaces.....	1.34
$A$ for dull metallic surfaces.....	1.58
$A$ for lampblack.....	1.78

When a metal plate has a liquid at each side of it, it appears from experiments by Péclet that  $B = 0.058$ ,  $A = 8.8$ .

The results of experiments on the evaporative power of boilers agree very well with the following approximate formula for the thermal resistance of boiler plates and tubes:

$$e + e' = \frac{a}{(T' - T)},$$

which gives for the rate of conduction, per square foot of surface per hour,

$$q = \frac{(T' - T)^2}{a}.$$

This formula is proposed by Rankine as a rough approximation, near enough to the truth for its purpose. The value of  $a$  lies between 160 and 200. Experiments on modern boilers usually give higher values.

**Convection**, or carrying of heat, means the transfer and diffusion of the heat in a fluid mass by means of the motion of the particles of that mass.

The conduction, properly so called, of heat through a stagnant mass of fluid is very slow in liquids, and almost, if not wholly, inappreciable in gases. It is only by the continual circulation and mixture of the particles of the fluid that uniformity of temperature can be maintained in the fluid mass, or heat transferred between the fluid mass and a solid body.

The free circulation of each of the fluids which touch the side of a solid plate is a necessary condition of the correctness of Rankine's formula for the conduction of heat through that plate; and in these formulæ it is



plied that the circulation of each of the fluids by currents and eddies is such as to prevent any considerable difference of temperature between the fluid particles in contact with one side of the solid plate and those at considerable distances from it.

When heat is to be transferred by convection from one fluid to another, through an intervening layer of metal, the motions of the two fluid masses should, if possible, be in opposite directions, in order that the hottest particles of each fluid may be in communication with the hottest particles of the other, and that the minimum difference of temperature between the adjacent particles of the two fluids may be the greatest possible.

Thus, in the surface condensation of steam, by passing it through metal tubes immersed in a current of cold water or air, the cooling fluid should be made to move in the opposite direction to the condensing steam.

**Coefficients of Heat Conduction of Different Materials.** (W. Nusselt, *Zeit des Ver. Deut. Ing.*, June, 1908. *Eng. Digest*, Aug., 1908.)—The materials were inclosed between two concentric metal vessels, the inner of which contained an electric heating device.

It was found that the materials tested all followed Fourier's law, the quantity of heat transmitted being directly proportional to the extent of surface, the duration of flow and the temperature difference between the inner and outer surfaces; and inversely proportional to the thickness of the mass of material. It was also found that the coefficient of conduction increased as the temperature increased. The table gives the British equivalents of the average coefficients obtained.

COEFFICIENTS OF HEAT CONDUCTION AT DIFFERENT TEMPERATURES FOR VARIOUS INSULATING MATERIALS.

(B.T.U. per hour = Area of surface in square feet × coefficient ÷ thickness in inches.)

Lb. per cu. ft.	Materials.	32° F.	212° F.	392° F.	572° F.	752° F.
10.	Ground cork .....	0.250	0.387	0.443	.....	.....
8.5	Sheep's wool* .....	0.266	0.403	.....	.....	.....
6.3	Silk waste .....	0.306	0.411	.....	.....	.....
9.18	Silk, tufted .....	0.314	0.419	.....	.....	.....
5.06	Cotton wool .....	0.379	0.476	.....	.....	.....
11.86	Charcoal (carbonized cabbage leaves) .....	0.403	0.508	.....	.....	.....
13.42	Sawdust (0.443 at 112° F.) .....	.....	.....	.....	.....	.....
10.	Peat refuse† (0.443 at 77° F.) .....	.....	.....	.....	.....	.....
27.85	Kieselguhr (infusorial earth), loose .....	0.419	0.532	0.596	0.629	.....
12.49	Asphalt-cork composition (0.492 at 65° F.) .....	.....	.....	.....	.....	.....
25.28	Composition,‡ loose .....	0.484	0.613	0.653	.....	.....
12.49	Kieselguhr stone§ .....	0.516	0.629	0.742	0.854	0.961
12.17	Peat refuse† (0.564 at 68° F.) .....	.....	.....	.....	.....	.....
36.2	Kieselguhr, dry and compacted (0.669 at 302° F.; 0.991 at 662° F.) .....	.....	.....	.....	.....	.....
43.07	Composition,§§ compacted (0.806 at 302° F.; 0.967 at 428° F.) .....	.....	.....	.....	.....	.....
22.47	Porous blast-furnace slag (0.766 at 112° F.) .....	.....	.....	.....	.....	.....
35.96	Asbestos (1.644 at 1112° F.) .....	1.048	1.346	1.451	1.499	1.548
34.33	Slag concrete   (1.532 at 112° F.) .....	.....	.....	.....	.....	.....
18.23	Pumice stone gravel (1.612 at 112° F.) .....	.....	.....	.....	.....	.....
128.5	Portland cement, neat (6.287 at 95° F.) .....	.....	.....	.....	.....	.....

\* Tufted, oily, and containing foreign matter. Used in Linde's apparatus. † Hygroscopic; measurements made in moist zones. ‡ Cork, asbestos, kieselguhr and chopped straw, mixed with a binder and made in sheets for application to steam pipes in successive layers, the whole being wrapped in canvas and painted. § Kieselguhr, mixed with a binder and burned; very porous and hygroscopic. §§ Ingredients of (†) mixed with water and compacted. || 1 part cement, 9 parts porous blast-furnace slag, by volume.

**Heat Resistance, the Reciprocal of Heat Conductivity.** (W. Kent, *Trans. A. S. M. E.*, xxiv, 278.)—The resistance to the passage of heat through a plate consists of three separate resistances: viz., the resistances of the two surfaces and the resistance of the body of the plate, which latter is proportional to the thickness of the plate. It is probable also that the resistance of the surface differs with the nature of the body or medium with which it is in contact.

A complete set of experiments on the heat-resisting power of heat-insulating substances should include an investigation into the difference in surface resistance when a surface is in contact with air and when it is in contact with another solid body. Suppose we find that the total resistance of a certain non-conductor may be represented by the figure 10, and that similar pieces all give the same figure. Two pieces in contact give 16. One piece of half the thickness of the others gives 8. What is the resistance of the surface exposed to the air in either piece, of the surface in contact with another surface, and of the interior of the body itself? Let the resistance of the material itself, of the regular thickness, be represented by  $A$ , that of the surface exposed to the air by  $a$ , and that of the surface in contact with another surface by  $c$ .

We then have for the three cases,

$$\begin{array}{l} \text{Resistance of one piece} \dots\dots\dots A + 2a = 10 \\ \text{" of two pieces in contact} \dots\dots\dots 2A + 2c + 2a = 16 \\ \text{" of the thin piece} \dots\dots\dots \frac{1}{2}A + 2a = 8 \end{array}$$

These three equations contain three unknown quantities. Solving the equations we find  $A = 4$ ,  $a = 3$ , and  $c = 1$ . Suppose that another experiment be made with the two pieces separated by an air space, and that the total resistance is then 22. If the resistance of the air space be represented by  $s$  we have the two equations: Resistance of one piece,  $A + 2a = 10$ ; resistance of two pieces and air space,  $2A + 4a + s = 22$ , from which we find  $s = 2$ . Having these results we can easily estimate what will be the resistance to heat transfer of any number of layers of the material, whether in contact or separated by air spaces.

The writer has computed the figures for heat resistance of several insulating substances from the figures of conducting power given in a table published by John E. Starr, in *Ice and Refrigeration*, Nov., 1901. Mr. Starr's figures are given in terms of the B.T.U. transmitted per sq. ft. of surface per day per degree of difference of temperatures of the air adjacent to each surface. The writer's figures, those in the last column of the table given on p. 583, are calculated by dividing Mr. Starr's figures by 24, to obtain the hourly rate, and then taking their reciprocals. They may be called "coefficients of heat resistance" and defined as the reciprocals of the B.T.U. per sq. ft. per hour per degree of difference of temperature.

Analyzing some of the results given in the last column of the table, we observe that, comparing Nos. 2 and 3, 1 in. added thickness of pitch increased the coefficient 0.74; comparing Nos. 4 and 5, 1½ in. of mineral wool increased the coefficient 1.11. If we assume that the 1 in. of mineral wool in No. 4 was equal in heat resistance to the additional 1½ in. added in No. 5, or 1.11 reciprocal units, and subtract this from 5.22, we get 4.11 as the resistance of two 7/8-in. boards and two sheets of paper. This would indicate that one 7/8-in. board and one sheet of paper give nearly twice as much resistance as 1 in. of mineral wool. In like manner any number of deductions may be drawn from the table, and some of them will be rather questionable, such as the comparison of No. 15 and No. 16, showing that 1 in. additional sheet cork increased the resistance given by four sheets 6.67 reciprocal units, or one-third the total resistance of No. 15. This result is extraordinary, and indicates that there must have been considerable differences of conditions during the two tests.

For comparison with the coefficients of heat resistance computed from Mr. Starr's results we may take the reciprocals of the figures given by Mr. Alfred R. Wolff as the result of German experiments on the heat transmitted through various building materials, as below:

$K =$  B.T.U. transmitted per hour per sq. ft. of surface, per degree F. difference of temperature.

$C =$  coefficient of heat resistance = reciprocal of  $K$ .

The irregularity of the differences of  $C$  computed from the original values of  $K$  for each increase of 4 inches in thickness of the brick walls indicates a difference in the conditions of the experiments. The average

HEAT CONDUCTING AND RESISTING VALUES OF DIFFERENT MATERIALS.

Insulating Material.	Conductance, B.T.U. per Sq. Ft. per Day per Deg., Difference of Temperature.	Coefficient of Heat Resistance. C.
1. 5/8-in. oak board, 1 in. lampblack, 7/8-in. pine board (ordinary family refrigerator).....	5.7	4.21
2. 7/8-in. board, 1 in. pitch, 7/8-in. board.....	4.89	4.91
3. 7/8-in. board, 2 in. pitch, 7/8-in. board.....	4.25	5.65
4. 7/8-in. board, paper, 1 in. mineral wool, paper, 7/8-in. board.....	4.6	5.22
5. 7/8-in. board, paper, 2 1/2 in. mineral wool, paper, 7/8-in. board.....	3.62	6.63
6. 7/8-in. board, paper, 2 1/2 in. calcined pumice, 7/8-in. board.....	3.38	7.10
7. Same as above, when wet.....	3.90	6.15
8. 7/8-in. board, paper, 3 in. sheet cork, 7/8-in. board.....	2.10	11.43
9. Two 7/8-in. boards, paper, solid, no air space, paper, two 7/8-in. boards.....	4.28	5.61
10. Two 7/8-in. boards, paper, 1 in. air space, paper, two 7/8-in. boards.....	3.71	6.47
11. Two 7/8-in. boards, paper, 1 in. hair felt, paper, two 7/8-in. boards.....	3.32	7.23
12. Two 7/8-in. boards, paper, 8 in. mill shavings, paper, two 7/8-in. boards.....	1.35	17.78
13. The same, slightly moist.....	1.80	13.33
14. The same, damp.....	2.10	11.43
15. Two 7/8-in. boards, paper, 3 in. air, 4 in. sheet cork, paper, two 7/8-in. boards.....	1.20	20.00
16. Same, with 5 in. sheet cork.....	0.90	26.67
17. Same, with 4 in. granulated cork.....	1.70	14.12
18. Same, with 1 in. sheet cork.....	3.30	7.27
19. Four double 7/8-in. boards (8 boards), with paper between, three 8-in. air spaces.....	2.70	8.89
20. Four 7/8-in. boards, with three quilts of 1/4-in. hair between, papers separating boards...	2.52	9.52
21. 7/8-in. board, 6 in. patented silicated straw-board, finished inside with thin cement...	2.48	9.68

difference of *C* for each 4 inches of thickness is about 0.80. Using this average difference to even up the figures we find the value of *C* is expressed by the approximate formula  $C = 0.70 + 0.20 t$ , in which *t* is the thickness in inches. The revised values of *C*, computed by this formula, and the corresponding revised values of *K*, are as follows:

Thick., In.	4	8	12	16	20	24	28	32	36	40
<i>C</i> .....	1.50	2.30	3.10	3.90	4.70	5.50	6.30	7.10	7.90	8.70
<i>K</i> , revised..	0.667	0.435	0.323	0.256	0.213	0.182	0.159	0.141	0.127	0.115
<i>K</i> , original..	0.68	0.46	0.32	0.26	0.23	0.20	0.174	0.15	0.129	0.115
Difference..	0.013	0.025	0.003	0.004	0.017	0.018	0.015	0.009	0.002	0.0

The following additional values of *C* are computed from Mr. Wolff's figures for *K*:

	<i>K</i>	<i>C</i>
Wooden beams planked over or ceiled:		
As flooring.....	0.083	12.05
As ceiling.....	0.104	9.71
Fireproof construction, floored over:		
As flooring.....	0.124	8.06
As ceiling.....	0.145	6.90
Single window.....	1.030	0.97
Single skylight.....	1.118	0.89
Double window.....	0.518	1.93
Double skylight.....	0.621	1.61
Door.....	0.414	2.42



It should be noted that the coefficient of resistance thus defined will be approximately a constant quantity for a given substance under certain fixed conditions, only when the difference of temperature of the air on its two sides is small—say less than 100° F. When the range of temperature is great, experiments on heat transmission indicate that the quantity of heat transmitted varies, not directly as the difference of temperature, but as the square of that difference. In this case a coefficient of resistance with a different definition may be found—viz., that obtained from the formula  $a = (T - t)^2 \div q$ , in which  $a$  is the coefficient,  $T - t$  the range of temperature, and  $q$  the quantity of heat transmitted, in British thermal units per square foot per hour.

### Steam-pipe Coverings.

Experiments by Prof. Ordway, *Trans. A. S. M. E.*, vi, 168; also Circular No. 27 of Boston Mfrs. Mutual Fire Ins. Co., 1890.

Substance 1 In. Thick. Applied, 310° F.	Heat	Pounds of Water Heated 10° F., per Hour, Through 1 Sq. Ft.	British Thermal Units per Sq. Ft. per Minute.	Solid Mat- ter in 1 Sq. Ft., 1 In. Thick, Parts in 1000.	Air included, Parts in 100.
1. <i>Loose wool</i> .....		8.1	1.35	56	944
2. <i>Live-geese feathers</i> .....		9.6	1.60	50	950
3. <i>Carded cotton wool</i> .....		10.4	1.73	20	980
4. <i>Hair felt</i> .....		10.3	1.72	185	815
5. <i>Loose lampblack</i> .....		9.8	1.63	56	944
6. <i>Compressed lampblack</i> .....		10.6	1.77	244	756
7. <i>Cork charcoal</i> .....		11.9	1.98	53	947
8. <i>White-pine charcoal</i> .....		13.9	2.32	119	881
9. <i>Anthracite-coal powder</i> .....		35.7	5.95	506	494
10. <i>Loose calcined magnesia</i> .....		12.4	2.07	23	977
11. <i>Compressed calcined magnesia</i> ..		42.6	7.10	285	715
12. <i>Light carbonate of magnesia</i> ...		13.7	2.28	60	940
13. <i>Compressed carb. of magnesia</i> ..		15.4	2.57	150	850
14. <i>Loose fossil-meal</i> .....		14.5	2.42	60	940
15. <i>Crowded fossil-meal</i> .....		15.7	2.62	112	888
16. <i>Ground chalk (Paris white)</i> .....		20.6	3.43	253	747
17. <i>Dry plaster of Paris</i> .....		30.9	5.15	368	632
18. <i>Fine asbestos</i> .....		49.0	8.17	81	919
19. <i>Air alone</i> .....		48.0	8.00	0	1000
20. <i>Sand</i> .....		62.1	10.35	529	471
21. <i>Best slag-wool</i> .....		13.	2.17	.....	.....
22. <i>Paper</i> .....		14.	2.33	.....	.....
23. <i>Blotting-paper wound tight</i> .....		21.	3.50	.....	.....
24. <i>Asbestos paper wound tight</i> .....		21.7	3.62	.....	.....
25. <i>Cork strips bound on</i> .....		14.6	2.43	.....	.....
26. <i>Straw rope wound spirally</i> .....		18.	3.	.....	.....
27. <i>Loose rice chaff</i> .....		18.7	3.12	.....	.....
28. <i>Paste of fossil-meal with hair</i> ...		16.7	2.78	.....	.....
29. <i>Paste of fossil-meal with asbestos</i> ..		22.	3.67	.....	.....
30. <i>Loose bituminous-coal ashes</i> ....		21.	3.50	.....	.....
31. <i>Loose anthracite-coal ashes</i> ....		27.	4.50	.....	.....
32. <i>Paste of clay and vegetable fiber</i>		30.9	5.15	.....	.....

It will be observed that several of the incombustible materials are nearly as efficient as wool, cotton, and feathers, with which they may be compared in the preceding table. The materials which may be considered wholly free from the danger of being carbonized or ignited by slow contact with pipes or boilers are printed in Roman type. Those which are more or less liable to be carbonized are printed in italics.

The results Nos. 1 to 20 inclusive were from experiments with the various non-conductors each used in a mass one inch thick, placed on a flat surface of iron kept heated by steam to 310° F. The substances

Nos. 21 to 32 were tried as coverings for two-inch steam-pipe; the results being reduced to the same terms as the others for convenience of comparison.

Experiments on still air gave results which differ little from those of Nos. 3, 4, and 6. The bulk of matter in the best non-conductors is relatively too small to have any specific effect except to trap the air and keep it stagnant. These substances keep the air still by virtue of the roughness of their fibers or particles. The asbestos, No. 18, had smooth fibers. Asbestos with exceedingly fine fiber made a somewhat better showing, but asbestos is really one of the poorest non-conductors. It may be used advantageously to hold together other incombustible substances, but the less of it the better. A "magnesia" covering, made of carbonate of magnesia with a small percentage of good asbestos fiber and containing 0.25 of solid matter, transmitted 2.5 B.T.U. per square foot per minute, and one containing 0.396 of solid matter transmitted 3.33 B.T.U.

Any suitable substance which is used to prevent the escape of steam heat should not be less than one inch thick.

Any covering should be kept perfectly dry, for not only is water a good carrier of heat, but it has been found that still water conducts heat about eight times as rapidly as still air.

**Tests of Commercial Coverings** were made by Mr. Geo. M. Brill and reported in *Trans. A. S. M. E.*, xvi, 827. A length of 60 feet of 8-inch steam-pipe was used in the tests, and the heat loss was determined by the condensation. The steam pressure was from 109 to 117 lbs. gauge, and the temperature of the air from 58° to 81° F. The difference between the temperature of steam and air ranged from 263° to 286°, averaging 272°.

The following are the principal results:

Kind of Covering.	Thickness of Covering, inches.	Lbs. Steam condensed per sq. ft. per hour.	B.T.U. per sq. ft. per minute.	B.T.U. per sq. ft. per hour per degree of average difference of temperature.	Saving due to covering, lbs. steam per hour per sq. ft.	Ratio of Heat lost, Bare to Covered Pipe, %.	H.P. lost per 100 sq. ft. of pipe (30 lbs. per hour = 1 H.P.).
Bare pipe.....	.....	0.846	12.27	2.706	.....	100.	2.819
Magnesia.....	1.25	0.120	1.74	0.384	0.726	14.2	0.400
Rock wool.....	1.60	0.080	1.16	0.256	0.766	9.5	0.267
Mineral wool.....	1.30	0.089	1.29	0.285	0.757	10.5	0.297
Fire-felt.....	1.30	0.157	2.28	0.502	0.689	18.6	0.523
Manville sectional.....	1.70	0.109	1.59	0.350	0.737	12.9	0.364
Manv. sect and hair-felt	2.40	0.066	0.96	0.212	0.780	7.8	0.221
Manville wool-cement...	2.20	0.108	1.56	0.345	0.738	12.7	0.359
Champion mineral wool.	1.44	0.099	1.44	0.317	0.747	11.7	0.330
Hair-felt.....	0.82	0.132	1.91	0.422	0.714	15.6	0.439
Riley cement.....	0.75	0.298	4.32	0.953	0.548	35.2	0.993
Fossil-meal.....	0.75	0.275	3.99	0.879	0.571	32.5	0.919

**Tests of Pipe Coverings by an Electrical Method.** (H. G. Stott, *Power*, 1902.) — A length of about 200 ft. of 2-in. pipe was heated to a known temperature by an electrical current. The pipe was covered with different materials, and the heat radiated by each covering was determined by measuring the current required to keep the pipe at a constant temperature. A brief description of the various coverings is given below.

No. 2. Solid sectional covering, 1½ in. thick, of granulated cork molded under pressure and then baked at a temperature of 500° F.; ¼ in. asbestos paper next to pipe.

No. 3. Solid 1-in. molded sectional, 85% carbonate of magnesia.

No. 4. Solid 1-in. sectional, granulated cork molded under pressure and baked at 500° F.; 1/8 in. asbestos next to pipe.

No. 5. Solid 1-in. molded sectional, 85% carbonate of magnesia; outside of sections covered with canvas pasted on.

No. 6. Laminated 1-in. sectional, nine layers of asbestos paper with granulated cork between; outside of sections covered with canvas, 1/8 in. asbestos paper next to pipe.

No. 7. Solid 1-in. molded sectional, of 85% carbonate of magnesia; outside of sections covered with light canvas.

No. 8. Laminated 1-in. sectional, seven layers of asbestos paper indented with 1/4-in. square indentations, which serve to keep the asbestos layers from coming in close contact with one another; 1/8 in. asbestos paper next to pipe.

No. 9. Laminated 1-in. sectional, 64 layers of asbestos paper, in which were embedded small pieces of sponge; outside covered with canvas.

No. 10. Laminated 1 1/2-in. sectional, 12 plain layers of asbestos paper with corrugated layers between, forming longitudinal air cells; 1/8 in. asbestos paper next to pipe; sections wired on.

No. 11. Laminated 1-in. sectional, 8 layers of asbestos paper with corrugated layers between, forming small air ducts radially around the covering.

No. 12. Laminated 1 1/4-in. sectional, 6 layers of asbestos paper with corrugated layers; outside of sections covered with two layers of canvas.

No. 15. "Remanit," composed of 2 layers wound in reverse direction with ropes of carbonized silk. Inner layer 2 1/2 in. wide and 1/2 in. thick; outer layer 2 in. wide and 3/4 in. thick, over which was wound a network of fine wire; 1/8 in. asbestos next to pipe. Made in Germany.

No. 16. 2 1/2-in. covering, 85% carbonate of magnesia, 1/2-in. blocks about 3 in. wide and 18 in. long next to pipe and wired on; over these blocks were placed solid 2-in. molded sectional covering.

No. 17. 2 1/2-in. covering, 85% magnesia. Put on in a 2-in. molded section wired on; next to the pipe and over this a 1/2-in. layer of magnesia plaster.

No. 18. 2 1/2-in. covering, 85% carbonate of magnesia. Put on in two solid 1-in. molded sections with 1/2-in. layer of magnesia plaster between; two 1-in. coverings wired on and placed so as to break joints.

No. 19. 2-in. covering, of 85% carbonate of magnesia, put on in two 1-in. layers so as to break joints.

No. 20. Solid 2-in. molded sectional, 85% magnesia.

No. 21. Solid 2-in. molded sectional, 85% magnesia.

Two samples covered with the same thickness of similar material give different results; for example, Nos. 3 and 5, and also Nos. 20 and 21. The cause of this difference was found to be in the care with which the joints between sections were made. A comparison between Nos. 19 and 20, having the same total thickness, but one applied in a solid 2-in. section, and the other in two 1-in. sections, proved the desirability of breaking joints.

An attempt was made to determine the law governing the effect of increasing the thickness of the insulating material, and for all the 85% magnesia coverings the efficiency varied directly as the square root of the thickness, but the other materials tested did not follow this simple law closely, each one involving a different constant.

To determine which covering is the most economical the following quantities must be considered: (1) Investment in covering. (2) Cost of coal required to supply lost heat. (3) Five per cent interest on capital invested in boilers and stokers rendered idle through having to supply lost heat. (4) Guaranteed life of covering. (5) Thickness of covering.

The coverings Nos. 2 to 15 were finished on the outside with resin paper and 8-ounce canvas; the others had canvas pasted on outside of the sections, and an 8-oz. canvas finish. The following is a condensed statement of the results with the temperature of the pipe corresponding to 160 lb. steam pressure.



ELECTRICAL TEST OF STEAM-PIPE COVERINGS.

No.	Covering.	Aver. Thickness.	B.T.U. Loss per Min. per sq. ft. at 160 lb. Pres.	B.T.U. per sq. ft. per Hr. per Deg. Diff. of Temp.	Per cent Heat Saved by Covering.
2	Solid cork.....	1.68	1.672	0.348	87.1
3	85% magnesia.....	1.18	2.008	0.418	84.5
4	Solid cork.....	1.20	2.048	0.427	84.2
5	85% magnesia.....	1.19	2.130	0.444	83.6
6	Laminated asbestos cork.....	1.48	2.123	0.442	83.7
7	85% magnesia.....	1.12	2.190	0.456	83.2
8	Asbestos air cell [indent].....	1.26	2.333	0.486	83.1
9	Asbestos sponge felted.....	1.24	2.552	0.532	80.3
10	Asbestos air cell [long].....	1.70	2.750	0.573	78.8
11	"Asbestoscel" [radial].....	1.22	2.801	0.584	78.5
12	Asbestos air cell [long].....	1.29	2.812	0.586	78.4
15	"Remanit" [silk] wrapped.....	1.51	1.452	0.302	88.8
16	85% magnesia, 2" sectional and 1/2" block.....	2.71	1.381	0.288	89.4
17	85% magnesia, 2" sectional and 1/2" plaster.....	2.45	1.387	0.289	88.7
18	85% magnesia, two 1" sectional.....	2.50	1.412	0.294	89.0
19	85% magnesia, two 1" sectional.....	2.24	1.465	0.305	88.7
20	85% magnesia, 2" sectional.....	2.34	1.555	0.324	88.0
21	85% magnesia, 2" sectional.....	2.20	1.568	0.314	87.9
	Bare pipe [from outside tests].....	.....	13.	2.708	.....

**Transmission of Heat, through Solid Plates, from Water to Water.** (Clark, S. E.) — M. Pécelet found, from experiments made with plates of wrought iron, cast iron, copper, lead, zinc, and tin, that when the fluid in contact with the surface of the plate was not circulated by artificial means, the rate of conduction was the same for different metals and for plates of the same metal of different thicknesses. But when the water was thoroughly circulated over the surfaces, and when these were perfectly clean, the quantity of transmitted heat was inversely proportional to the thickness, and directly as the difference in temperature of the two faces of the plate. When the metal surface became dull, the rate of transmission of heat through all the metals was very nearly the same.

It follows, says Clark, that the absorption of heat through metal plates is more active whilst evaporation is in progress — when the circulation of the water is more active — than while the water is being heated up to the boiling-point.

**Transmission from Steam to Water.** — M. Pécelet's principle is supported by the results of experiments made in 1867 by Mr. Isherwood on the conductivity of different metals. Cylindrical pots, 10 inches in diameter, 21 1/4 inches deep inside, and 1/8 inch, 1/4 inch, and 3/8 inch thick, turned and bored, were formed of pure copper, brass (60 copper and 40 zinc), rolled wrought iron, and remelted cast iron. They were immersed in a steam bath, which was varied from 220° to 320° F. Water at 212° was supplied to the pots, which were kept filled. It was ascertained that the rate of evaporation was in the direct ratio of the difference of the temperatures inside and outside of the pots; that is, that the rate of evaporation per degree of difference of temperatures was the same for all temperatures; and that the rate of evaporation was exactly the same for different thicknesses of the metal. The respective rates of conductivity of the several metals were as follows, expressed in weight of water evaporated from and at 212° F. per square foot of the interior surface of the pots per degree of difference of temperature per hour, together with the equivalent quantities of heat-units:

	Water at 212°.	Heat-units.	Ratio.
Copper.....	0.665 lb.	642.5	1.00
Brass.....	.577 "	556.8	0.87
Wrought iron.....	.387 "	373.6	.58
Cast iron.....	.327 "	315.7	.49

Whitham, "Steam Engine Design," p. 283, also *Trans. A. S. M. E.*, ix, 425, in using these data in deriving a formula for surface condensers, calls these figures those of perfect conductivity, and multiplies them by a coefficient *C*, which he takes at 0.323, to obtain the efficiency of condenser surface in ordinary use, i.e., coated with saline and greasy deposits.

**Transmission of Heat from Steam to Water through Coils of Iron Pipe.** — H. G. C. Kopp and F. J. Meystre (*Stevens Indicator*, Jan., 1894) give an account of some experiments on transmission of heat through coils of pipe. They collate the results of earlier experiments as follows, for comparison:

Experimenter.	Character of Surface.	Steam condensed per square foot per degree difference of temperature per hour.		Heat transmitted per square foot per degree difference of temperature per hour.		Remarks.
		Heating, pounds.	Evapo-rating, pounds.	Heating, B.T.U.	Evapo-rating, B.T.U.	
Laurens.	Copper coils..	0.292	0.981	315	974	{ Steam pressure = 100. { Steam pressure = 10.
"	2 Copper coils .....		1.20		1120	
Havrez..	Copper coil...	0.268	1.26	280	1200	
Perkins..	Iron coil.....		0.24		215	
"	" " .....		0.22		208.2	
Box.....	Iron tube.....	0.235		230		
" .....	" " .....	0.196		207		
" .....	" " .....	0.206		210		
Havrez..	Cast-iron boiler	0.077	0.105	82	100	

From the above it would appear that the efficiency of iron surfaces is less than that of copper coils, plate surfaces being far inferior.

In all experiments made up to the present time, it appears that the temperature of the condensing water was allowed to rise, a mean between the initial and final temperatures being accepted as the effective temperature. But as water becomes warmer it circulates more rapidly, thereby causing the water surrounding the coil to become agitated and replaced by cooler water, which allows more heat to be transmitted.

Again, in accepting the mean temperature as that of the condensing medium, the assumption is made that the rate of condensation is in direct proportion to the temperature of the condensing water.

In order to correct and avoid any error arising from these assumptions and approximations, experiments were undertaken, in which all the conditions were constant during each test.

The pressure was maintained uniform throughout the coil, and provision was made for the free outflow of the condensed steam, in order to obtain at all times the full efficiency of the condensing surface. The condensing water was continually stirred to secure uniformity of temperature, which was regulated by means of a steam-pipe and a cold-water pipe entering the tank in which the coil was placed.

The following is a condensed statement of the results.

HEAT TRANSMITTED PER SQUARE FOOT OF COOLING SURFACE, PER HOUR, PER DEGREE OF DIFFERENCE OF TEMPERATURE. (British Thermal Units.)

Temperature of Condensing Water.	1-in. Iron Pipe; Steam inside, 60 lbs. Gauge Pressure.	1 1/2-in. Pipe; Steam inside, 10 lbs. Pressure.	1 1/2-in. Pipe; Steam outside, 10 lbs. Pressure.	1 1/2-in. Pipe; Steam inside, 60 lbs. Pressure.
80	265	128	200	.....
100	269	130	230	239
120	272	137	260	247
140	277	145	267	276
160	281	158	271	306
180	299	174	270	349
200	313	.....	.....	419

The results indicate that the heat transmitted per degree of difference of temperature in general increases as the temperature of the condensing water is increased.

The amount transmitted is much larger with the steam on the outside of the coil than with the steam inside the coil. This may be explained in part by the fact that the condensing water when inside the coil flows over the surface of conduction very rapidly, and is more efficient for cooling than when contained in a tank outside of the coil.

This result is in accordance with that found by Mr. Thomas Craddock, which indicated that the rate of cooling by transmission of heat through metallic surfaces was almost wholly dependent on the rate of circulation of the cooling medium over the surface to be cooled.

**Transmission of Heat in Condenser Tubes.** (*Eng'g*, Dec. 10, 1875, p. 449.) — In 1874 B. C. Nichol made experiments for determining the rate at which heat was transmitted through a condenser tube. The results went to show that the amount of heat transmitted through the walls of the tube per estimated degree of mean difference of temperature increased considerably with this difference. For example:

Estimated mean difference of temperature between inside and outside of tube, degrees Fahr....	Vertical Tube.			Horizontal Tube.		
	128	151.9	152.9	111.6	146.2	150.4
Heat-units transmitted per hour per square foot of surface per degree of mean diff. of temp....	422	531	561	610	737	823

These results seem to throw doubt upon Mr. Isherwood's statement that the rate of evaporation per degree of difference of temperature is the same for all temperatures.

Mr. Thomas Craddock found that water was enormously more efficient than air for the abstraction of heat through metallic surfaces in the process of cooling. He proved that the rate of cooling by transmission of heat through metallic surfaces depends upon the rate of circulation of the cooling medium over the surface to be cooled. A tube filled with hot water, moved by rapid rotation at the rate of 59 ft. per second, through air, lost as much heat in one minute as it did in still air in 12 minutes. In water, at a velocity of 3 ft. per second, as much heat was abstracted in half a minute as was abstracted in one minute when it was at rest in the water. Mr. Craddock concluded, further, that the circulation of the cooling fluid became of greater importance as the difference of temperature on the two sides of the plate became less. (*Clark, R. T. D.*, p. 461.)

G. A. Orrok (*Power*, Aug. 11, 1908) gives a diagram showing the relation of the B.T.U. transmitted per hour per sq. ft. of surface per degree of difference of temperature to the velocity of the water in the condenser tubes, in feet per second, as obtained by different experimenters. Approximate figures taken from the several curves are given below.



Authority.	Tubes.	Velocity of Water, Feet per Second.						
		0.5	1	2	3	4	5	6
		B.T.U. per sq. ft. per hr. per deg. diff.						
1. Stanton.....	1/2-in. vert. copper.....	.....	325	400	465	520	550	...
2. Stanton.....	1/2-in. vert. copper.....	.....	420	470	525	560	585	...
3. Nichols.....	3/4-in. vert. brass.....	.....	340	370	405	435	460	470
4. Nichols.....	3/4-in. horiz. brass.....	.....	500	530	560	585	615	650
5. Hepburn.....	1 1/4-in. horiz. copper.....	250	365	590	.....	.....	.....	.....
6. Hepburn.....	1 1/4-in. horiz. corrugated	360	560	.....	.....	.....	.....	.....
7. Richter.....	1 1/2-in. horiz. corrugated	460	.....	.....	.....	.....	.....	.....
8. Weighton.....	5/8-in. plain tubes.....	.....	380	615	760	865	940	.....
9. Allen.....	5/8-in. horizontal.....	.....	225	290	365	.....	.....	.....

No. 1, water flowing up. Nos. 2 and 3, water flowing down.

**Transmission of Heat in Feed-water Heaters.** (W. R. Billings, *The National Engineer*, June, 1907.) — Experiments show that the rate of transmission of heat through metal surfaces from steam to water increases rapidly with the increased rate of flow of the water. Mr. Billings therefore recommends the use of small tubes in heaters in which the water is inside of the tubes. He says: A high velocity through the tubes causes friction between the water and the walls of the tubes; this friction is not the same as the friction between the particles of water themselves, and it tends to break up the column of water and bring fresh and cooler particles against the hot walls of the tubes.

The following results were obtained in tests:

1 1/4-in. smooth tubes	{	$V = 22.5$	114	137	...
	{	$U = 185$	570	670	...
1 1/2-in. corrugated tubes	{	$V = 24$	34	43	82
	{	$U = 318$	444	465	735

$V$  = velocity of the water, ft. per min.  $U$  = B.T.U. transmitted per sq. ft. per hour per degree difference of temperature. (See Condensers.)

In calculations of heat transmission in heaters it is customary to take as the mean difference of temperature the difference between the temperature of the steam and the arithmetical mean of the initial and final temperatures of the water; thus if  $S$  = steam temperature,  $I$  = initial and  $F$  = final temperature of the water, and  $D$  = mean difference, then  $D = S - 1/2(I + F)$ . Mr. Billings shows that this is incorrect, and on the assumption that the rate of transmission through any portion of the surface is directly proportional to the difference he finds the true mean

to be  $D = \frac{F - I}{\text{hyp. log} [(S - I) \div (S - F)]}$ . (This formula was derived by Cecil P. Poole in 1899, *Power*, Dec., 1906.)

The following table is calculated from the formula:

DEGREES OF DIFFERENCE BETWEEN STEAM TEMPERATURE AND ACTUAL AVERAGE TEMPERATURE OF WATER.

Initial Temperature of Water.	Vacuum Heaters Between Engine and Condenser.									
	26" Vac. Temp. 126° F.				24" Vac. Temp. 141° F.					
	Final Temp. of Water.				Final Temp. of Water.					
	105	110	115	120	105	110	115	120	125	130
40.....	46.1	41.6	36.9	30.1	62.9	60.2	55.3	50.9	46.1	40.6
50.....	42.8	38.4	33.6	27.6	59.2	56.6	51.8	47.7	43.2	37.9
60.....	39.3	35.3	30.7	25.0	55.5	52.1	48.4	44.4	40.1	35.0
70.....	35.6	31.9	27.6	22.4	51.6	48.2	45.0	41.0	36.9	32.2
80.....	31.8	28.3	24.5	19.6	47.6	44.2	41.2	37.5	33.6	29.2

Initial Temp. of Water.	Atmospheric Heaters.												
	Atmos. Press. 212° F. Temp.						Initial Temp. of Water.	Atmos. Press. 212° F. Temp.					
	Final Temp. of Water.							Final Temp. of Water.					
	192	196	200	204	208	210	192	196	200	204	208	210	
40.....	70.6	65.7	60.1	53.5	44.8	38.0	105	51.9	47.9	43.4	38.2	31.4	26.4
50.....	67.9	63.1	57.6	51.2	42.8	36.4	110	50.3	46.4	42.1	36.9	30.2	25.5
60.....	65.1	60.4	55.2	48.9	40.7	34.7	115	48.8	45.0	40.6	35.7	29.2	24.5
70.....	62.2	57.7	52.6	46.6	38.7	32.9	120	47.2	43.5	39.2	34.4	28.0	23.5
80.....	59.4	54.9	50.0	44.2	36.6	31.0	125	45.6	41.9	37.8	33.1	26.9	22.5

The error in using the arithmetic mean for the value of *D* is not important if *F* is very much lower than *S*, but if it is within 10° of *S* then the error may be a large one. With *S* = 212, *I* = 40, *F* = 110, the arithmetic mean difference is 137, and the value by the logarithmic formula 131, an error of less than 5%; but if *F* is 204, the arithmetic mean is 90, and the value by the formula 53.5.

It should be observed, however, that the formula is based on an assumption that is probably greatly in error for high temperature differences, i.e., that the transmission of heat is directly proportional to the temperature difference. It may be more nearly proportional to the square of the difference, as stated by Rankine. This seems to be indicated by the results of heating water by steam coils, given below.

**Heating Water by Steam Coils.** — A catalogue of the American Radiator Co. (1908) gives a chart showing the pounds of steam condensed per hour per sq. ft. of iron, brass and copper pipe surface, for different mean or average differences of temperature between the steam and the water. Taking the latent heat of the steam at 966 B.T.U. per lb., the following figures are derived from the table.

Mean Temp. Diff.	Lb. Steam Condensed per Hour per Sq. Ft. of Pipe.			Lb. Steam Condensed per Hour per Sq. Ft. per Deg. Diff.			B.T.U. per Sq. Ft. per Hour per Deg. Diff.		
	Iron.	Brass.	Copper	Iron.	Brass.	Copper	Iron.	Brass	Cop.
50	7.5	12.5	14.5	0.150	0.250	0.290	101	198	280
100	18.5	38	43.5	0.185	0.380	0.435	179	367	415
150	32.2	76.5	87.8	0.215	0.510	0.585	208	493	565
200	48	128	144	0.240	0.640	0.720	232	618	696

The chart is said to be plotted from a large number of tests with pipes placed vertically in a tank of water, about 20 per cent being deducted from the actual results as a margin of safety.

W. R. Billings (*Eng. Rec.*, Feb., 1898) gives as the results of one set of experiments with a closed feed-water heater:

Diff. bet. temp. of steam and final temp. of water, deg. F. ....	5	6	8	11	15	18
B.T.U. per sq. ft. per hr. per deg. mean diff. . . . .	67	79	89	114	129	139

**Heat Transmission through Cast-iron Plates Pickled in Nitric Acid.** — Experiments by R. C. Carpenter (*Trans. A. S. M. E.*, xii, 179) show a marked change in the conducting power of the plates (from steam to water), due to prolonged treatment with dilute nitric acid.

The action of the nitric acid, by dissolving the free iron and not attacking the carbon, forms a protecting surface to the iron, which is largely composed of carbon. The following is a summary of results:

Character of Plates, each plate 8.4 in. by 5.4 in., exposed surface 27 sq. ft.	Increase in Temperature of 3.125 lbs. of Water each Minute.	Proportionate Thermal Units Transmitted for each Degree of Difference of Temperature per Square Foot per Hour.	Relative Transmission of Heat.
Cast iron—untreated skin on, but clean, free from rust.....	13.90	113.2	100.0
Cast iron—nitric acid, 1% sol., 9 days..	11.5	97.7	86.3
“ “ “ 1% sol., 18 days	9.7	80.08	70.7
“ “ “ 1% sol., 40 days	9.6	77.8	68.7
“ “ “ 5% sol., 9 days..	9.93	87.0	76.8
“ “ “ 5% sol., 40 days	10.6	77.4	68.5
Plate of pine wood, same dimensions as the plate of cast iron.....	0.33	1.9	1.6

The effect of covering cast-iron surfaces with varnish has been investigated by P. M. Chamberlain. He subjected the plate to the action of strong acid for a few hours, and then applied a non-conducting varnish. One surface only was treated. Some of his results are as follows:

Heat units per sq. ft. per hour, for each degree, $\tau$	{	170. As finished — greasy.
		152. “ “ washed with benzine and dried.
		169. Oiled with lubricating oil.
		162. After exposure to nitric acid sixteen hours, then oiled (linseed oil).
		166. After exposure to hydrochloric acid twelve hours, then oiled (linseed oil).
		113. { After exposure to sulphuric acid 1, water 2, for 48 hours, then oiled, varnished, and allowed to dry for
		117. { 24 hours.

**Transmission of Heat through Solid Plates from Air or other Dry Gases to Water.** (From Clark on the Steam Engine.) — The law of the transmission of heat from hot air or other gases to water, through metallic plates, has not been exactly determined by experiment. The general results of experiments on the evaporative action of different portions of the heating surface of a steam-boiler point to the general law that the quantity of heat transmitted per degree difference of temperature is practically uniform for various differences of temperature.

The communication of heat from the gas to the plate surface is much accelerated by mechanical impingement of the gaseous products upon the surface.

Clark says that when the surfaces are perfectly clean, the rate of transmission of heat through plates of metal from air or gas to water is greater for copper, next for brass, and next for wrought iron. But when the surfaces are dimmed or coated, the rate is the same for the different metals.

With respect to the influence of the conductivity of metals and of the thickness of the plate on the transmission of heat from burnt gases to water, Mr. Napier made experiments with small boilers of iron and copper placed over a gas-flame. The vessels were 5 inches in diameter and 2 1/2 inches deep. From three vessels, one of iron, one of copper, and one of iron sides and copper bottom, each of them 1/30 inch in thickness,



equal quantities of water were evaporated to dryness, in the times as follows:

Water.	Iron Vessel.	Copper Vessel.	Iron and Copper Vessel.
4 ounces	19 minutes	18.5 minutes	.....
11 "	33 "	30.75 "	.....
5 1/2 "	50 "	44 "	.....
4 "	35.7 "	.....	36.83 minutes

Two other vessels of iron sides 1/30 inch thick, one having a 1/4-inch copper bottom and the other a 1/4-inch lead bottom, were tested against the iron and copper vessel, 1/30 inch thick. Equal quantities of water were evaporated in 54, 55, and 53 1/2 minutes respectively. Taken generally, the results of these experiments show that there are practically but slight differences between iron, copper, and lead in evaporative activity, and that the activity is not affected by the thickness of the bottom.

Mr. W. B. Johnson formed a like conclusion from the results of his observations of two boilers of 160 horse-power each, made exactly alike, except that one had iron flue-tubes and the other copper flue-tubes. No difference could be detected between the performances of these boilers.

Divergencies between the results of different experimenters are attributable probably to the difference of conditions under which the heat was transmitted, as between water or steam and water, and between gaseous matter and water. On one point the divergence is extreme: the rate of transmission of heat per degree of difference of temperature. Whilst from 400 to 600 units of heat are transmitted from water to water through iron plates, per degree of difference per square foot per hour, the quantity of heat transmitted between water and air, or other dry gas, is only about from 2 to 5 units, according as the surrounding air is at rest or in movement. In a locomotive boiler, where radiant heat was brought into play, 17 units of heat were transmitted through the plates of the fire-box per degree of difference of temperature per square foot per hour.

**Transmission of Heat through Plates from Flame to Water.** — Much controversy has arisen over the assertion by some makers of live-steam feed-water heaters that if the water fed to a boiler was first heated to the boiling point before being fed into the boiler, by means of steam taken from the boiler, an economy of fuel would result; the theory being that the rate of transmission through a plate to water was very much greater when the water was boiling than when it was being heated to the boiling point, on account of the greatly increased rapidity of circulation of the water when boiling. (See *Eng'g*, Nov. 16, 1906, and *Eng. Review* [London], Jan., 1908.) Two experiments by Sir Wm. Anderson (1872), with a steam-jacketed pan, are quoted, one of which showed an increased transmission when boiling of 133%, and the other of 80%; also an experiment by Sir F. Bramwell, with a steam-heated copper pan, which showed a gain of 164% with boiling water. On the other hand, experiments by S. B. Bilbrough (Transvaal Inst. Mining Engineers, Feb., 1908) showed in tests with a flame-heated pan that there was no difference in the rate of transmission whether the water was cold or boiling. W. M. Sawdon (*Power*, Jan. 12, 1909) objects to Mr. Bilbrough's conclusions on the ground that no corrections for radiation were made, and finds by a similar experiment, with corrections; that the increased rate of transmission with boiling water is at least 38%. All of these experiments were on a small scale, and in view of their conflict no conclusions can be drawn from them as to the value of live-steam feed-water heating in improving the economy of a steam boiler.

**A. Blechynden's Tests.** — A series of steel plates from 0.125 in. to 1.187 in. thick were tested with hot gas on one side and water on the other with differences of temperature ranging from 373° to 1318° F. (*Trans. Inst. Naval Architects*, 1894.) Mr. Blechynden found that the heat transmitted is proportional to the square of the difference between the temperatures at the two sides of the plate, or: Heat transmitted per sq. ft. ÷ (diff. of temp.)<sup>2</sup> = a constant. A study of the results of these tests is made in Kent's "Steam Boiler Economy," p. 325, and it is shown that the value of *a* in Rankine's formula  $q = (T_1 - T)^2 \div a$ , which *a* is the reciprocal of Mr. Blechynden's constant and is a function of the thickness of the plate. One of the plates, *A*, originally 1.187 in. thick, was reduced

in four successive operations, by machining to 0.125 in. Another, *B*, was tested in four thicknesses. The other plates were tested in one or two thicknesses. Each plate was found to have a law of transmission of its own. For plate *A* the value of *a* is represented closely by the formula  $a = 40 + 20t$ , in which *t* is the thickness in inches. The formula  $a = 40 + 20t \pm 10$  covers the whole range of the experiments. The whole range of values is 38.6 to 71.9, which are very low when compared with values of *a* computed from the results of boiler tests, which are usually from 200 to 400, the low values obtained by Blechynden no doubt being due to the exceptionally favorable conditions of his tests as compared with those of boiler tests. Rankine says the value of *a* lies between 160 and 200, but values below 200 are rarely found in tests of modern types of boilers. (See Steam-Boilers.)

**Cooling of Air.** — H. F. Benson (*Am. Mach.*, Aug. 31, 1905) derives the following formula for transmission of heat from air to water through copper tubes. It is assumed that the rate of transmission at any point of the surface is directly proportional to the difference of temperature between the air and water.

Let *A* = cooling surface, sq. ft.; *K* = lb. of air per hour; *S<sub>a</sub>* = specific heat of air; *T<sub>a1</sub>* = temp. of hot inlet air; *T<sub>a2</sub>* = temp. of cooled outlet air; *d* = actual average diff. of temp. between the air and the water; *U* = B.T.U. absorbed by the water per degree of diff. of temp. per sq. ft. per hour. *W* = lb. of water per hour; *T<sub>w1</sub>* = temp. of inlet water; *T<sub>w2</sub>* = temp. of outlet water. Then

$$AdU = KS_a(T_{a1} - T_{a2}); \quad A = KS_a(T_{a1} - T_{a2}) \div dU.$$

$$d = [(T_{a1} - T_{a2}) - (T_{w2} - T_{w1})] \div \log [(T_{a1} - T_{w2}) \div (T_{a2} - T_{w1})].$$

$$AU = \frac{KS_a W}{W - KS_a} \log_e \frac{T_{a1} - T_{w2}}{T_{a2} - T_{w1}}.$$

$$T_{w2} = (S_a K \div W)(T_{a1} - T_{a2}) + T_{w1}.$$

The more cooling water used, the lower is the temperature *T<sub>w2</sub>*. Also the less *T<sub>w2</sub>* is, the larger *d* becomes and the less surface is needed. About 10 is the largest value of *W/K* that it is economical to use, as there is a saving of less than 0.5% in increasing it from 10 to 15. When desirable to save water it will be advisable to make *W/K* = 5. Values of *U* obtained by experiment with a Wainwright cooler made with corrugated copper tubes are given in the following table. *K* and *W* are in lb. per minute, *B<sub>a</sub>* = B.T.U. from air per min., *B<sub>w</sub>* = B.T.U. from water per min., *Vw* = velocity of water, ft. per min.

<i>T<sub>a1</sub></i>	<i>T<sub>a2</sub></i>	<i>T<sub>w1</sub></i>	<i>T<sub>w2</sub></i>	<i>K</i>	<i>W</i>	<i>B<sub>a</sub></i>	<i>B<sub>w</sub></i>	<i>V<sub>w</sub></i>	<i>U</i>
221.0	76.3	50.0	169.0	125.2	28.50	4303	3392	2.20	6.75
217.0	64.3	45.8	146.4	122.8	36.73	4452	3695	2.84	7.12
224.0	63.3	45.7	149.2	126.3	40.30	4819	4171	3.11	7.91
209.6	54.0	43.8	125.9	122.1	50.00	4511	4105	3.86	8.81
214.5	46.3	43.0	106.2	124.6	68.95	4976	4357	5.32	10.55
234.6	63.6	52.6	120.2	124.4	73.25	5051	4852	5.65	8.41
214.2	43.5	43.0	94.7	117.3	79.84	4753	4128	6.16	14.32
242.9	61.7	55.3	114.0	133.6	92.72	5649	5443	7.15	10.01
223.0	46.0	40.1	79.1	130.5	114.80	5484	4477	8.86	7.86
239.3	57.5	51.0	95.2	130.0	125.70	5612	5556	9.70	9.38
246.0	58.0	52.3	95.1	133.8	145.90	5977	6244	11.26	10.57

Sixteen other tests were made besides those given above, and their plotted results all come within the field covered by those in the table.

There is apparently an error in the last line of the table, for the heat gained by the water could not be greater than that lost by the air. The excess lost by the air may be due to radiation, but it shows a great irregularity. It appears that for velocities of water between 2.2 and 5.3 ft. per min. the value of  $U$  increases with the velocity, but for higher velocities the value of  $U$  is very irregular, and the cause of the irregularity is not explained.

Chas. L. Hubbard (*The Engineer*, Chicago, May 18, 1902) made some tests by flowing air through a tight wooden box which contained a nest of 30 1 $\frac{1}{2}$ -in. tin tubes, of a total surface of about 20 sq. ft., through which cold water flowed. The results were as follows:

Cu. ft. of air per minute.....	268	268	469	469	636	636
Velocity over cooling surface.....	638	638	1116	1116	1514	1514
Initial temperature of air.....	72°	72°	72°	74°	74°	74°
Drop in temperature.....	8°	12°	8°	10°	8°	10°
Average temp. of water.....	50°	43°	48°	48°	50°	44°
Average temp. of air.....	68°	66°	68°	69°	70°	68°
Difference.....	18°	23°	20°	21°	20°	24°
B.T.U. per hour per sq. ft. per degree difference.....	6.5	7.6	10.2	12.1	13.8	14.4

**Transmission of Heat through Plates and Tubes from Steam or Hot Water to Air.** — The transfer of heat from steam or water through a plate or tube into the surrounding air is a complex operation, in which the internal and external conductivity of the metal, the radiating power of the surface, and the convection of heat in the surrounding air, are all concerned. Since the quantity of heat radiated from a surface varies with the condition of the surface and with the surroundings, according to laws not yet determined, and since the heat carried away by convection varies with the rate of the flow of the air over the surface, it is evident that no general law can be laid down for the total quantity of heat emitted.

The following is condensed from an article on "Loss of Heat from Steam-pipes," in *The Locomotive*, Sept. and Oct., 1892.

A hot steam-pipe is radiating heat constantly off into space, but at the same time it is cooling also by convection. Experimental data on which to base calculations of the heat radiated and otherwise lost by steam-pipes are neither numerous nor satisfactory.

In Box's "Practical Treatise on Heat" a number of results are given for the amount of heat radiated by different substances when the temperature of the air is 1° Fahr. lower than the temperature of the radiating body. A portion of this table is given below. It is said to be based on Péclet's experiments.

HEAT UNITS RADIATED PER HOUR, PER SQUARE FOOT OF SURFACE, FOR 1° FAHRENHEIT EXCESS IN TEMPERATURE.

Copper, polished.....	0.0327	Glass.....	0.5948
Tin, polished.....	0.0440	Cast iron, new.....	0.6480
Zinc and brass, polished...	0.0491	Common steam-pipe, in-	
Tinned iron, polished.....	0.0858	ferred.....	0.6400
Sheet iron, polished.....	0.0920	Cast and sheet iron, rusted..	0.6868
Sheet lead.....	0.1329	Wood, building stone, and	
Sheet iron, ordinary.....	0.5662	brick.....	0.7358

When the temperature of the air is about 50° or 60° Fahr., and the radiating body is not more than about 30° hotter than the air, we may calculate the radiation of a given surface by assuming the amount of heat given off by it in a given time to be proportional to the difference in temperature between the radiating body and the air. This is "Newton's law of cooling." But when the difference in temperature is great, Newton's law does not hold good; the radiation is no longer proportional to the difference in temperature, but must be calculated by a complex formula established experimentally by Dulong and Petit. Box has computed a table from this



formula, which greatly facilitates its application, and which is given below:

FACTORS FOR REDUCTION TO DULONG'S LAW OF RADIATION.

Differences in Temperature between Radiating Body and the Air.	Temperature of the Air on the Fahrenheit Scale.											
	32°	50°	59°	68°	86°	104°	122°	140°	158°	176°	194°	212°
Deg. Fahr.												
18	1.00	1.07	1.12	1.16	1.25	1.36	1.47	1.58	1.70	1.85	1.99	2.15
36	1.03	1.11	1.16	1.21	1.30	1.40	1.52	1.68	1.76	1.91	2.06	2.23
54	1.07	1.16	1.20	1.25	1.35	1.45	1.58	1.70	1.83	1.99	2.14	2.31
72	1.12	1.20	1.25	1.30	1.40	1.52	1.64	1.76	1.90	2.07	2.23	2.40
90	1.16	1.25	1.31	1.36	1.46	1.58	1.71	1.84	1.98	2.15	2.33	2.51
108	1.21	1.31	1.36	1.42	1.52	1.65	1.78	1.92	2.07	2.28	2.42	2.62
126	1.26	1.36	1.42	1.48	1.60	1.72	1.86	2.00	2.16	2.34	2.52	2.72
144	1.32	1.42	1.48	1.54	1.65	1.79	1.94	2.08	2.24	2.44	2.64	2.83
162	1.37	1.48	1.54	1.60	1.73	1.86	2.02	2.17	2.34	2.54	2.74	2.96
180	1.44	1.55	1.61	1.68	1.81	1.95	2.11	2.27	2.46	2.66	2.87	3.10
198	1.50	1.62	1.69	1.75	1.89	2.04	2.21	2.38	2.56	2.78	3.00	3.24
216	1.58	1.69	1.76	1.83	1.97	2.13	2.32	2.48	2.68	2.91	3.13	3.38
234	1.64	1.77	1.84	1.90	2.06	2.23	2.43	2.52	2.80	3.03	3.28	3.46
252	1.71	1.85	1.92	2.00	2.15	2.33	2.52	2.71	2.92	3.18	3.43	3.70
270	1.79	1.93	2.01	2.09	2.26	2.44	2.64	2.84	3.06	3.32	3.58	3.87
288	1.89	2.03	2.12	2.20	2.37	2.56	2.78	2.99	3.22	3.50	3.77	4.07
306	1.98	2.13	2.22	2.31	2.49	2.69	2.90	3.12	3.37	3.66	3.95	4.26
324	2.07	2.23	2.33	2.42	2.62	2.81	3.04	3.28	3.53	3.84	4.14	4.46
342	2.17	2.34	2.44	2.54	2.73	2.95	3.19	3.44	3.70	4.02	4.34	4.68
360	2.27	2.45	2.56	2.66	2.86	3.09	3.35	3.60	3.88	4.22	4.55	4.91
378	2.39	2.57	2.68	2.79	3.00	3.24	3.51	3.78	4.08	4.42	4.77	5.15
396	2.50	2.70	2.81	2.93	3.15	3.40	3.68	3.97	4.28	4.64	5.01	5.40
414	2.63	2.84	2.95	3.07	3.31	3.56	3.87	4.12	4.48	4.87	5.26	5.67
432	2.76	2.98	3.10	3.23	3.47	3.76	4.10	4.32	4.61	5.12	5.53	6.04

The loss of heat by *convection* appears to be independent of the nature of the surface, that is, it is the same for iron, stone, wood, and other materials. It is different for bodies of different shape, however, and it varies with the position of the body. Thus a vertical steam-pipe will not lose so much heat by convection as a horizontal one will; for the air heated at the lower part of the vertical pipe will rise along the surface of the pipe, protecting it to some extent from the chilling action of the surrounding cooler air. For a similar reason the shape of a body has an important influence on the result, those bodies losing most heat whose forms are such as to allow the cool air free access to every part of their surface. The following table from Box gives the number of heat units that horizontal cylinders or pipes lose by convection per square foot of surface per hour, for one degree difference in temperature between the pipe and the air.

HEAT UNITS LOST BY CONVECTION FROM HORIZONTAL PIPES, PER SQUARE FOOT OF SURFACE PER HOUR, FOR A TEMPERATURE DIFFERENCE OF 1° FAHR.

External Diameter of Pipe in Inches.	Heat Units Lost.	External Diameter of Pipe in Inches.	Heat Units Lost.	External Diameter of Pipe in Inches.	Heat Units Lost.
2	0.728	7	0.509	18	0.455
3	0.626	8	0.498	24	0.447
4	0.574	9	0.489	36	0.438
5	0.544	10	0.482	48	0.434
6	0.523	12	0.472	.....	.....

The loss of heat by convection is nearly proportional to the difference in temperature between the hot body and the air, but the experiments of Dulong and Péclet show that this is not exactly true, and we may here also resort to a table of factors for correcting the results obtained by simple proportion.

FACTORS FOR REDUCTION TO DULONG'S LAW OF CONVECTION.

Difference in Temp. between Hot Body and Air.	Factor.	Difference in Temp. between Hot Body and Air.	Factor.	Difference in Temp. between Hot Body and Air.	Factor.
18° F.	0.94	180° F.	1.62	342° F.	1.87
36°	1.11	198°	1.65	360°	1.90
54°	1.22	216°	1.68	378°	1.92
72°	1.30	234°	1.72	396°	1.94
90°	1.37	252°	1.74	414°	1.96
108°	1.43	270°	1.77	432°	1.98
126°	1.49	288°	1.80	450°	2.00
144°	1.53	306°	1.83	468°	2.02
162°	1.58	324°	1.85	.....	.....

EXAMPLE IN THE USE OF THE TABLES. — Required the total loss of heat by both radiation and convection, per foot of length of a steam-pipe  $2\frac{11}{32}$  in. external diameter, steam pressure 60 lbs., temperature of the air in the room 68° Fahr.

Temperature corresponding to 60 lbs. equals 307°; temperature difference =  $307 - 68 = 239^\circ$ .

Area of one foot length of steam-pipe =  $2\frac{11}{32} \times 3.1416 \div 12 = 0.614$  sq. ft.

Heat radiated per hour per square foot per degree of difference, from table, 0.64.

Radiation loss per hour by Newton's law =  $239^\circ \times 0.614 \text{ ft.} \times 0.64 = 93.9$  heat units. Same reduced to conform with Dulong's law of radiation: factor from table for temperature difference of 239° and temperature of air 68° = 1.93.  $93.9 \times 1.93 = 181.2$  heat units, total loss by radiation.

Convection loss per square foot per hour from a  $2\frac{11}{32}$ -inch pipe: by interpolation from table,  $2'' = 0.728$ ,  $3'' = 0.626$ ,  $2\frac{11}{32}'' = 0.693$ .

Area,  $0.614 \times 0.693 \times 239^\circ = 101.7$  heat units. Same reduced to conform with Dulong's law of convection:  $101.7 \times 1.73$  (from table) = 175.9 heat units per hour. Total loss by radiation and convection =  $181.2 + 175.9 = 357.1$  heat units per hour. Loss per degree of difference of temperature per linear foot of pipe per hour =  $357.1 \div 239 = 1.494$  heat units = 2.433 per sq. ft.

It is not claimed, says *The Locomotive*, that the results obtained by this method of calculation are strictly accurate. The experimental data are not sufficient to allow us to compute the heat-loss from steam-pipes with any great degree of refinement; yet it is believed that the results obtained as indicated above will be sufficiently near the truth for most purposes. An experiment by Prof. Ordway, in a pipe  $2\frac{11}{32}$  in. diam. under the above conditions (*Trans. A. S. M. E.*, v. 73), showed a condensation of steam of 181 grams per hour, which is equivalent to a loss of heat of 358.7 heat units per hour, or within half of one per cent of that given by the above calculation.

The quantity of heat given off by steam and hot-water radiators in ordinary practice of heating buildings by direct radiation varies from 1.25 to about 3.25 heat units per hour per square foot per degree of difference of temperature. (See Heating and Ventilation.)

THERMODYNAMICS.

Thermodynamics, the science of heat considered as a form of energy, is useful in advanced studies of the theory of steam, gas, and air engines, refrigerating machines, compressed air, etc. The method of treatment adopted by the standard writers is severely mathematical, involving constant application of the calculus. The student will find the subject

thoroughly treated in the works by Rontgen (Dubois's translation), Wood, Peabody, and Zeuner.

**First Law of Thermodynamics.** — Heat and mechanical energy are mutually convertible in the ratio of about .778 foot-pounds for the British thermal unit. (Wood.)

**Second Law of Thermodynamics.** — The second law has by different writers been stated in a variety of ways, and apparently with ideas so diverse as not to cover a common principle. (Wood, Therm., p. 389.)

It is impossible for a self-acting machine, unaided by any external agency, to convert heat from one body to another at a higher temperature. (Clausius.)

If all the heat absorbed be at one temperature, and that rejected be at one lower temperature, then will the heat which is transmuted into work be to the entire heat absorbed in the same ratio as the difference between the absolute temperature of the source and refrigerator is to the absolute temperature of the source. In other words, the second law is an expression for the efficiency of the perfect elementary engine. (Wood.)

The expression  $\frac{Q_1 - Q_2}{Q_1} = \frac{T_1 - T_2}{T_1}$  may be called the symbolical or algebraic enunciation of the second law, — the law which limits the efficiency of heat engines, and which does not depend on the nature of the working medium employed. (Trowbridge.)  $Q_1$  and  $T_1$  = quantity and absolute temperature of the heat received;  $Q_2$  and  $T_2$  = quantity and absolute temperature of the heat rejected.

The expression  $\frac{T_1 - T_2}{T_1}$  represents the efficiency of a perfect heat engine which receives all its heat at the absolute temperature  $T_1$ , and rejects heat at the temperature  $T_2$ , converting into work the difference between the quantity received and rejected.

**EXAMPLE.** — What is the efficiency of a perfect heat engine which receives heat at  $388^\circ$  F. (the temperature of steam of 200 lbs. gauge pressure) and rejects heat at  $100^\circ$  F. (temperature of a condenser, pressure 1 lb. above vacuum)?

$$\frac{388 + 459.2 - (100 + 459.2)}{388 + 459.2} = 34\%, \text{ nearly.}$$

In the actual engine this efficiency can never be attained, for the difference between the quantity of heat received into the cylinder and that rejected into the condenser is not all converted into work, much of it being lost by radiation, leakage, etc. In the steam engine the phenomenon of cylinder condensation also tends to reduce the efficiency.

**The Carnot Cycle.** — Let one pound of gas of a pressure  $p_1$ , volume  $v_1$  and absolute temperature  $T_1$  be enclosed in an ideal cylinder, having non-conducting walls but the bottom a perfect conductor, and having a moving non-conducting frictionless piston. Let the pressure and volume of the gas be represented by the point  $A$  on the  $pv$  or pressure-volume diagram, Fig. 142, and let it pass through four operations, as follows:

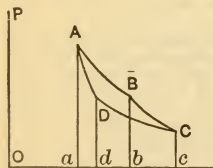

FIG. 142.

1. Apply heat at a temperature of  $T_1$  to the bottom of the cylinder and let the gas expand, doing work against the piston, at the constant temperature  $T_1$ , or isothermally, to  $p_2v_2$ , or  $B$ .

2. Remove the source of heat and put a non-conducting cover on the bottom, and let the gas expand adiabatically, or without transmission of heat, to  $p_3v_3$ , or  $C$ , while its temperature is being reduced to  $T_2$ .

3. Apply to the bottom of the cylinder a cold body, or refrigerator, of the temperature  $T_2$ , and let the gas be compressed by the piston isothermally to the point  $D$ , or  $p_4v_4$ , rejecting heat into the cold body.

4. Remove the cold body, restore the non-conducting bottom, and compress the gas adiabatically to  $A$ , or the original  $p_1v_1$ , while its temperature is being raised to the original  $T_1$ . The point  $D$  on the isothermal line  $CD$  is chosen so that an adiabatic line passing through it will also pass through  $A$ , and so that  $v_4/v_1 = v_3/v_2$ .

The area  $aABCc$  represents the work done by the gas on the piston;



the area  $CDAac$  the negative work, or the work done by the piston on the gas; the difference,  $ABCD$ , is the net work.

1a. The area  $aABBb$  represents the work done during isothermal expansion. It is equal in foot-pounds to  $W_1 = p_1 v_1 \log_e (v_2/v_1)$ , where  $p_1$  = the initial absolute pressure in lbs. per sq. ft. and  $v_1$  = the initial volume in cubic feet. It is also equal to the quantity of heat supplied to the gas, =  $U_1 = RT_1 \log_e (v_2/v_1)$ .  $R$  is a constant for a given gas, = 53.35 for air.

2a. The area  $bBCc$  is the work done during adiabatic expansion, =  $W_2 = \frac{p_2 v_2}{\gamma - 1} \left\{ 1 - \left( \frac{v_2}{v_3} \right)^{\gamma - 1} \right\}$ ,  $\gamma$  being the ratio of the specific heat at constant pressure to the specific heat at constant volume. For air  $\gamma = 1.406$ . The loss of intrinsic energy =  $K_v(T_1 - T_2)$  ft.-lbs.  $K_v$  = specific heat at constant volume  $\times 778$ .

3a.  $CDdc$  is the work of isothermal compression, =  $W_3 = p_4 v_4 \log_e (v_3/v_4)$  = heat rejected =  $U_2 = RT_2 \log_e (v_3/v_4)$ .

4a.  $DAad$  is the work of adiabatic compression

$$= W_4 = \frac{p_1 v_1}{\gamma - 1} \left\{ 1 - \left( \frac{v_1}{v_4} \right)^{\gamma - 1} \right\},$$

which is the same as  $W_2$  and therefore, being negative, cancels it, and the net work  $ABCD = W_1 - W_3$ . The gain of intrinsic energy is  $K_v(T_1 - T_2)$ .

Comparing 1a and 3a, we have  $p_1 v_1 = p_2 v_2$ ;  $p_3 v_3 = p_4 v_4$ ;  $v_2/v_3 = v_1/v_4 = r$ .

$$W_1 = p_1 v_1 \log_e r = RT_1 \log_e r; \quad W_3 = p_4 v_4 \log_e r = RT_2 \log_e r.$$

$$\begin{aligned} \text{Efficiency } \frac{W_1 - W_3}{W_1} &= \frac{R(T_1 - T_2) \log_e r}{RT_1 \log_e r} = \frac{T_1 - T_2}{T_1} = 1 - \frac{T_2}{T_1} \\ &= 1 - \left( \frac{v_2}{v_3} \right)^{\gamma - 1} = \frac{U_1 - U_2}{U_1}. \end{aligned}$$

**Entropy.**—In the  $pv$  or pressure-volume diagram, energy exerted or expended is represented by an area the lines of which show the changes of the values of  $p$  and  $v$ . In the Carnot cycle these changes are shown by curved lines. If a given quantity of heat  $Q$  is added to a substance at a constant temperature, we may represent it by a rectangular area in which the temperature is represented by a vertical line, and the base is the quotient of the area divided by the length of the vertical line. To this quotient is given the name entropy. When the temperature at which the heat is added is not constant a more general definition is needed, viz.: *Entropy is length on a diagram the area of which represents a quantity of heat, and the height at any point represents absolute temperature.* The value of the increase of entropy is given in the language of

calculus,  $E = \int_{T_2}^{T_1} \frac{dQ}{T}$ , which may be interpreted thus: increase of entropy

between the temperatures  $T_2$  and  $T_1$  equals the summation of all the quotients arising by dividing each small quantity of heat added by the absolute temperature at which it is added. It is evident that if the several small quantities of heat added are equal, while the values of  $T$  constantly increase, the quotients are not equal, but are constantly decreasing. The diagram, called the temperature-entropy diagram, or the  $\theta\phi$ , theta-phi, diagram, is one in which the abscissas, or horizontal distances, represent entropy, and vertical distances absolute temperature. The horizontal distances are measured from an arbitrary vertical line representing entropy at  $32^\circ \text{F.}$ , and values of entropy are given as values beyond that point, while the temperatures are measured above absolute zero. Horizontal lines are isothermals, vertical lines adiabatics. The usefulness of entropy in thermodynamic studies is due to the fact that in many cases it simplifies calculations and makes it possible to use algebraic or graphical methods instead of the more difficult methods of the calculus.

**The Carnot Cycle in the Temperature-Entropy Diagram.**—Let a pound of gas having a temperature  $T_1$  and entropy  $E$  be subjected to the four operations described above. (1)  $T_1$  being constant, heat (area  $aABc$ , Fig. 143) is added and the entropy increases from  $A$  to  $B$ ; isothermal expansion. (2) No heat is transferred, as heat, but the temperature is reduced from  $T_1$  to  $T_2$ ; entropy constant; adiabatic expansion. (3) Heat is rejected at the constant temperature  $T_2$ , the area  $CcaD$  being subtracted; entropy decreases from  $C$  to  $D$ ; isothermal compression. (4) Entropy constant, temperature increases from  $D$  to  $A$ , or from  $T_2$  to  $T_1$ ; no heat transferred as heat; adiabatic compression. The area  $aABc$  represents the total heat added during the cycle, the area  $cCDA$  the heat rejected; the difference, or the area  $ABCD$ , is the heat utilized or converted into work. The ratio of this area to the whole area

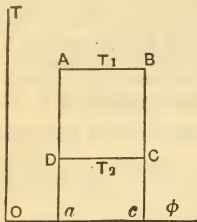

FIG. 143.

$aABc$  is the efficiency; it is the same as the ratio  $(T_1 - T_2) \div T_1$ . It appears from this diagram that the efficiency may be increased by increasing  $T_1$  or by decreasing  $T_2$ ; also that since  $T_2$  cannot be lowered by any self-acting engine below the temperature of the surrounding atmosphere, say  $460^\circ + 62^\circ \text{ F.} = 522^\circ \text{ F.}$ , it is not possible even in a perfect engine to obtain an efficiency of 50 per cent unless the temperature of the source of heat is above  $1000^\circ \text{ F.}$  It is shown also by this diagram that the Carnot cycle gives the highest possible efficiency of a heat engine working between any given temperatures  $T_1$  and  $T_2$ , and that the admission and rejection of heat each at a constant temperature gives a higher efficiency than the admission or rejection at any variable temperatures within the range  $T_1 - T_2$ .

**The Reversed Carnot Cycle—Refrigeration.**—Let a pound of cool gas whose temperature and entropy are represented by the "state-point"  $D$  on the diagram (1) receive heat at a constant temperature  $T_2$  (the temperature of a refrigerating room) until its entropy is  $C$ ; (2) then let it be compressed adiabatically (no heat transmission,  $CB$ ) to a high temperature  $T_1$ ; (3) then let it reject heat into the atmosphere at this temperature  $T_1$  (isothermal compression); (4) then let it expand adiabatically, doing work, as through a throttled expansion cock, or by pushing a piston, it will then cool to a temperature which may be far below that of the atmosphere and be used to absorb heat from the atmosphere. (See Refrigeration.)

**Principal Equations of a Perfect Gas.**—Notation:  $P$  = pressure in lb. per sq. ft.  $V$  = volume in cu. ft.  $P_0V_0$ , pressure and volume at  $32^\circ \text{ F.}$   $T$ , absolute temperature =  $t^\circ \text{ F.} + 459.6$ .  $C_p$ , specific heat at constant pressure.  $C_v$ , specific heat at constant volume.  $K_p = C_p \times 777.6$ ;  $K_v = C_v \times 777.6$ ; specific heats taken in foot-pounds of energy.  $R$ , a constant, =  $K_p - K_v$ .  $\gamma = C_p/C_v$ .  $r$  = ratio of isothermal expansion or compression =  $P_2/P_1$  or  $V_1/V_2$ .

For air:  $C_p = 0.2375$ ;  $C_v = 0.1689$ ;  $K_p = 184.8$ ;  $K_v = 131.4$ ;  $R = 53.32$ ;  $\gamma = 1.406$ .

*Boyle's Law*,  $PV = \text{constant}$  when  $T$  is constant.  $P_1V_1 = P_2V_2$ . For 1 lb. air  $P_0V_0 = 2116.3 \times 12.387 = 26,215 \text{ ft.-lb.}$

*Charles's Law*,  $P_1V_1/T_1 = P_2V_2/T_2$ ;  $P_1V_1 = P_0V_0 \times T_1/T_0$ ;  $T_0 = 32 + 459.6 = 491.6$ ;  $P_1V_1$  for air =  $26,215 \div 491.6 = 53.32$ .

*General Equation*,  $PV = RT$ .  $R$  is a constant which is different for different gases.

*Internal or Intrinsic Energy*  $K_v(T_1 - T_0) = R(T_1 - T_0) \div (\gamma - 1) = P_1V_1 \div (\gamma - 1) = \text{amount of heat in a body, measured above absolute zero.}$  For air at  $32^\circ \text{ F.}$ ,  $K_v(T_1 - T_0) = 131.4 \times 491.6 = 64,600 \text{ ft.-lb.}$  When air is expanded or compressed isothermally,  $PV = \text{constant}$ , and the internal energy remains constant, the work done in expansion = the heat added, and the work done in compression = the heat rejected.

*Work done by Adiabatic Expansion*, no transmission of heat, from  $P_1V_1$  to  $P_2V_2 = P_1V_1 \left\{ 1 - (V_1/V_2)^{\gamma-1} \right\} \div (\gamma - 1)$ ,  $= (P_1V_1 - P_2V_2) \div (\gamma - 1)$   
 $= P_1V_1 \left\{ 1 - (P_2/P_1)^{\frac{\gamma-1}{\gamma}} \right\} \div (\gamma - 1)$ .

*Work of Adiabatic Compression* from  $P_1V_1$  to  $P_2V_2$  ( $P_2$  here being the higher pressure)  $= P_1V_1 \left\{ (V_1/V_2)^{\gamma-1} - 1 \right\} \div (\gamma - 1) = (P_2V_2 - P_1V_1) \div \gamma - 1$

$$= P_1V_1 \left\{ (P_2/P_1)^{\frac{\gamma-1}{\gamma}} - 1 \right\} \div (\gamma - 1).$$

*Loss of Intrinsic Energy* in adiabatic expansion, or gain in compression  $= K_v(T_1 - T_2)$ ,  $T_1$  being the higher temperature.

*Work of Isothermal Expansion*, temperature constant, = heat expended  $= P_1V_1 \log_e V_2/V_1 = P_1V_1 \log_e r = RT \log_e r$ .

*Work of Isothermal Compression* from  $P_1$  to  $P_2 = P_1V_1 \log_e P_1/P_2 = RT \log_e r =$  heat discharged.

*Relation between Pressure, Volume and Temperature:*

$$P_2 = P_1 \left( \frac{V_1}{V_2} \right)^\gamma = P_1 \left( \frac{T_2}{T_1} \right)^{\frac{\gamma}{\gamma-1}}, \quad V_2 = V_1 \left( \frac{P_1}{P_2} \right)^{\frac{1}{\gamma}} = V_1 \left( \frac{T_1}{T_2} \right)^{\frac{1}{\gamma-1}}.$$

$$T_2 = T_1 \left( \frac{P_2}{P_1} \right)^{\frac{\gamma-1}{\gamma}} = T_1 \left( \frac{V_1}{V_2} \right)^{\gamma-1}, \quad P_1V_1^\gamma = P_2V_2^\gamma.$$

For air,  $\gamma = 1.406$ ;  $\gamma - 1 = 0.406$ ;  $1/\gamma = 0.711$ ;  $1/(\gamma - 1) = 2.463$ ;  $\gamma/(\gamma - 1) = 3.463$ ;  $(\gamma - 1)/\gamma = 0.289$ .

*Differential Equations of a Perfect Gas.*  $Q =$  quantity of heat.  $\phi =$  entropy.

$$dQ = C_v dT + (C_p - C_v) \frac{T}{V} dV, \quad d\phi = C_v \frac{dT}{T} + (C_p - C_v) \frac{dV}{V}.$$

$$dQ = C_p dT + (C_v - C_p) \frac{T}{P} dV, \quad d\phi = C_p \frac{dT}{T} + (C_v - C_p) \frac{dP}{P}.$$

$$dQ = C_v \frac{T}{P} dP + C_p \frac{T}{P} dV, \quad d\phi = C_v \frac{dP}{P} + C_p \frac{dV}{V}.$$

$$\phi_2 - \phi_1 = C_v \log_e \frac{T_2}{T_1} + (C_p - C_v) \log_e \frac{V_2}{V_1}.$$

$$\phi_2 - \phi_1 = C_p \log_e \frac{T_2}{T_1} + (C_v - C_p) \log_e \frac{P_1}{P_2}.$$

$$\phi_2 - \phi_1 = C_v \log_e \frac{P_2}{P_1} + C_p \log_e \frac{V_2}{V_1}.$$

*Work of Isothermal Expansion*,  $W = P_1V_1 \int_{V_1}^{V_2} \frac{dV}{V} = P_1V_1 \log_e \frac{V_2}{V_1}$ .

Heat supplied during isothermal expansion,

$$Q = (C_p - C_v) T_1 \int_{V_1}^{V_2} \frac{dV}{V} = (C_p - C_v) T_1 \log_e \frac{V_2}{V_1}.$$

Heat added = work done  $= ART_1 \log_e V_2/V_1 = AP_1V_1 \log_e V_2/V_1$ ; ( $A = 1/778$ ).

*Work of adiabatic expansion,*

$$W = \int_{V_1}^{V_2} P dV = V_1^\gamma P_1 \int_{V_1}^{V_2} \frac{dV}{V^\gamma} = \frac{P_1V_1}{\gamma-1} \left\{ 1 - \left( \frac{V_1}{V_2} \right)^{\gamma-1} \right\}.$$



**Construction of the Curve  $PV^n = C$ .** (*Am. Mach.*, June 21, 1900).—Referring to Fig. 144, on a system of rectangular coördinates  $YOX$  lay

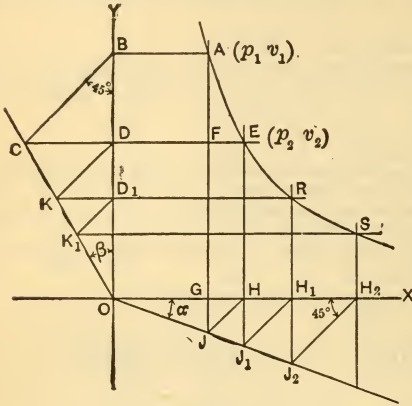

FIG. 144.

off  $OB = p_1$  and  $BA = v_1$ . Draw  $OJ$ , extended, at any convenient angle  $\alpha$ , say  $15^\circ$ , with  $OX$ , and  $OC$  at an angle  $\beta$  with  $OY$ .  $\beta$  is found from the equation  $1 + \tan \beta = [1 + \tan \alpha]^n$ . Draw  $AJ$  parallel to  $YO$ . From  $B$  draw  $BC$  at  $45^\circ$  with  $BO$ , and draw  $CE$  parallel to  $OX$ . From  $J$  draw  $JH$  at  $45^\circ$  with  $AJ$ , and draw  $HE$  and  $HJ_1$  parallel to  $YO$ . The intersection of  $CE$  and  $HE$  is the second point on the curve, or  $p_2v_2$ . From  $J_1$  draw  $J_1H_1$  at  $45^\circ$  to  $HJ_1$ , and draw the vertical  $J_2H_1R$ . Draw  $DK$  at  $45^\circ$  to  $DO_1$  and  $KR$  parallel to  $OX$ .  $R$  is the third point on the curve, and so on.

Conversely, if we have a curve for which we wish to derive an exponent, we can, by working backward, locate the lines  $OC$  and  $OJ$ , measure the angles  $\alpha$  and  $\beta$ , and solve for  $n$ .

The smaller the angle  $\alpha$  is taken the more closely the points of the curve may be located. If  $\alpha = \beta$  the curve is the isothermal curve,  $pv = \text{constant}$ . If  $\alpha = 15^\circ$  and  $\beta = 21^\circ 30'$  the curve is the adiabatic for air,  $n = 1.41$ . (See Index of the Curve of an Air Diagram, p. 636.)

**Temperature-Entropy Diagram of Water and Steam.**—The line  $OA$ , Fig. 145, is the origin from which entropy is measured on horizontal

lines, and the line  $Og$  is the line of zero temperature, absolute. The diagram represents the changes in the state of one pound of water due to the addition or subtraction of heat or to changes in temperature. Any point on the diagram is called a "state point."  $A$  is the state of 1 lb. of water at  $32^\circ$  F., or  $492^\circ$  abs.,  $B$  the state at  $212^\circ$ , and  $C$  at  $392^\circ$  F., corresponding to about 226 lbs. absolute pressure. At  $212^\circ$  F. the area  $OABb$  is the heat added, and  $Ob$  is the increase of entropy. At  $392^\circ$  F.,  $bBcC$  is the further addition of heat, and the entropy, measured from  $OA$ , is  $Oc$ . The two quantities added are nearly the same, but the second increase of entropy is the smaller, since the mean temperature at which it is added is higher. If  $Q$  = the quantity of heat added, and  $T_1$  and  $T_2$  are respectively the lower and the higher temperatures, the addition of entropy,  $\phi$ , is approximately  $Q \div \frac{1}{2}(T_2 + T_1) = 180 \div \frac{1}{2}(672 + 492) = 0.3093$ . More accurately it is  $\phi = \log_e (T_2/T_1) = 0.3119$ . In both of these expressions it is assumed that the specific heat of water = 1 at all temperatures, which is not strictly true. Accurate values of the entropy of water, taking into account the variation in specific heat, will be found in Marks and Davis's Steam Tables.

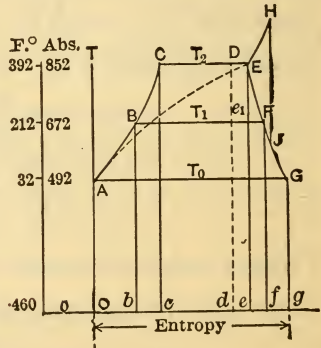

FIG. 145.

Let the 1 lb. of water at the state  $B$  have heat added to it at the con-

stant temperature of 212° F. until it is evaporated. The quantity of heat added will be the latent heat of evaporation at 212° (see Steam Table) or  $L = 970.4$  B.T.U., and it will be represented on the diagram by the rectangle  $bBFf$ . Dividing by  $T_1 = 672$ , the absolute temperature, gives  $\phi_2 - \phi_1 = 1.444 = BF$ . Adding  $\phi_1 = 0.312$  gives  $\phi_2 = 1.756$ , the entropy of 1 lb. steam at 212° F. measured from water at 32° F.

In like manner if we take  $L = 834.4$  for steam at 852° abs.,  $\phi_2 - \phi_1 = 0.980 = CE$ , and  $\phi_1 =$  entropy of water at 852° = 0.556, the sum  $\phi_2 = 1.536 = Oe$  on the diagram.

$E$  is the state point of dry saturated steam at 852° abs. and  $F$  the state point at 672°. The line  $EFG$  is the line of saturated steam and the line  $ABC$  the water line. The line  $CE$  represents the increase of entropy in the evaporation of water at 852° abs. If entropy  $CD$  only is added, or  $cCdd$  of heat, then a part of the water will remain unevaporated, viz.: the fraction  $DE/CE$  of 1 lb. The state point  $D$  thus represents wet steam having a dryness fraction of  $CD/DE$ .

If steam having a state point  $E$  is expanded adiabatically to 672° abs. its state point is then  $e_1$ , having the same entropy as at  $E$ , a total heat less by the amount represented by the area  $BCEe_1$ , and a dryness fraction  $Be_1/BF$ . If it is expanded while remaining saturated, heat must be added equal to  $eEFF$ , and the entropy increases by  $ef$ .

If heat is added to the steam at  $E$ , the temperature and the entropy both increase, the line  $EH$  representing the superheating, and the area  $EH$ , down to the line  $Og$ , is the heat added. If from the state point  $H$  the steam is expanded adiabatically, the state point follows the line  $HJ$  until it cuts the line  $EFG$ , when the steam is dry saturated, and if it crosses this line the steam becomes wet.

If the state point follows a horizontal line to the left, it represents condensation at a constant temperature, the amount of heat rejected being shown by the area under the horizontal line. If heat is rejected at a decreasing temperature, corresponding with the decreasing pressure at release in a steam engine, or condensation in a cylinder at a decreasing pressure, the state point follows a curved line to the left, as shown in the dotted curved line on the diagram.

In practical calculations with the entropy-temperature diagram it is necessary to have at hand tables or charts of entropy, total heat, etc., such as are given in Peabody's or Marks and Davis's Steam Tables, and other works. The diagram is of especial service in the study of steam turbines, and an excellent chart for this purpose will be found in Moyer's Steam Turbine. It gives for all pressures of steam from 0.5 to 300 lbs. absolute, and for different degrees of dryness up to 300° of superheating, the total heat contents in B.T.U. per pound, the entropy, and the velocity of steam through nozzles.

## PHYSICAL PROPERTIES OF GASES.

(Additional matter on this subject will be found under Heat, Air, Gas and Steam.)

When a mass of gas is inclosed in a vessel it exerts a pressure against the walls. This pressure is uniform on every square inch of the surface of the vessel; also, at any point in the fluid mass the pressure is the same in every direction.

In small vessels containing gases the increase of pressure due to weight may be neglected, since all gases are very light; but where liquids are concerned, the increase in pressure due to their weight must always be taken into account.

**Expansion of Gases, Mariotte's Law.** — The volume of a gas diminishes in the same ratio as the pressure upon it is increased, if the temperature is unchanged.

This law is by experiment found to be very nearly true for all gases, and is known as Boyle's or Mariotte's law.

If  $p =$  pressure at a volume  $v$ , and  $p_1 =$  pressure at a volume  $v_1$ ,  $p_1v_1 = pv$ ;  $p_1 = \frac{v}{v_1} p$ ;  $pv = a$  constant.

The constant,  $C$ , varies with the temperature, everything else remaining the same.

Air compressed by a pressure of seventy-five atmospheres has a volume about 2% less than that computed from Boyle's law, but this is the greatest divergence that is found below 160 atmospheres pressure.

**Law of Charles.**—The volume of a perfect gas at a constant pressure is proportional to its absolute temperature. If  $v_0$  be the volume of a gas at  $32^\circ \text{F.}$ , and  $v_1$  the volume at any other temperature,  $t_1$ , then

$$v_1 = v_0 \left( \frac{t_1 + 459.6}{491.6} \right); v_1 = \left( 1 + \frac{t_1 - 32}{491.6} \right) v_0$$

or  $v_1 = [1 + 0.002034 (t_1 - 32)] v_0$ .

If the pressure also change from  $p_0$  to  $p_1$ ,

$$v_1 = v_0 \frac{p_0}{p_1} \left( \frac{t_1 + 459.6}{491.6} \right).$$

**The Densities** of the elementary gases are simply proportional to their atomic weights. The density of a compound gas, referred to hydrogen as 1, is one-half its molecular weight; thus the relative density of  $\text{CO}_2$  is  $\frac{1}{2} (12 + 32) = 22$ .

**Avogadro's Law.**—Equal volumes of all gases, under the same conditions of temperature and pressure, contain the same number of molecules.

To find the weight of a gas in pounds per cubic foot at  $32^\circ \text{F.}$ , multiply half the molecular weight of the gas by 0.00559. Thus 1 cu. ft. of marsh-gas,  $\text{CH}_4$ ,

$$= \frac{1}{2} (12 + 4) \times 0.00559 = 0.0447 \text{ lb.}$$

When a certain volume of hydrogen combines with one-half its volume of oxygen, there is produced an amount of water vapor which will occupy the same volume as that which was occupied by the hydrogen gas when at the same temperature and pressure.

**Physical Laws of Methane Gas.**—(P. F. Walker, *Trans. A. S. M. E.*, 1914.) The specific heat of  $\text{CH}_4$  under constant pressure at temperatures from  $18^\circ$  to  $218^\circ \text{C.}$  is 0.5929 according to Landolt and Börnstein's Tables. The same tables, on the authority of Lussana, give values of 0.5915 at a pressure of 1 atmosphere and 0.6919 at 30 atmospheres. The ratio of specific heats at constant pressure and constant volume is given variously at from 1.235 to 1.315. The gas shows a considerable variation from Boyle's law.  $PV = \text{constant}$ , or  $PV = P_1V_1$ . The variation amounts to as much as 4% in the case of  $\text{CH}_4$  gas at 300 lb. per square inch reduced to the equivalent volume at atmospheric pressure. The difference is of commercial importance when natural gas is sold measured at high pressures and the price based on the equivalent volume at atmospheric pressure. The relation of pressure and volume is expressed by  $PV^n = \text{a constant}$  and the value of  $n$  for  $\text{CH}_4$  ranges from 0.98 to 0.995, varying with pressure and temperature, averaging 0.99. Sufficient data are not yet available for the construction of tables showing the variation of the pressure-volume relation from that given by Boyle's law.

**Saturation Point of Vapors.**—A vapor that is not near the saturation point behaves like a gas under changes of temperature and pressure; but if it is sufficiently compressed or cooled, it reaches a point where it begins to condense: it then no longer obeys the same laws as a gas, but its pressure cannot be increased by diminishing the size of the vessel containing it, but remains constant, except when the temperature is changed. The only gas that can prevent a liquid evaporating seems to be its own vapor.

**Dalton's Law of Gaseous Pressures.**—Every portion of a mass of gas inclosed in a vessel contributes to the pressure against the sides of the vessel the same amount that it would have exerted by itself had no other gas been present.

**Mixtures of Vapors and Gases.**—The pressure exerted against the interior of a vessel by a given quantity of a perfect gas inclosed in it is the sum of the pressures which any number of parts into which such quantity might be divided would exert separately, if each were inclosed in a vessel of the same bulk alone, at the same temperature. Although this law is not exactly true for any actual gas, it is very nearly true for many. Thus if 0.080728 lb. of air at  $32^\circ \text{F.}$ , being inclosed in a vessel of one cubic foot capacity, exerts a pressure of one atmosphere, or 14.7 pounds, on each



square inch of the interior of the vessel, then will each additional 0.080728 lb. of air which is inclosed, at 32°, in the same vessel, produce very nearly an additional atmosphere of pressure. The same law is applicable to mixtures of gases of different kinds. For example, 0.12344 lb. of carbonic-acid gas, at 32°, being inclosed in a vessel of one cubic foot in capacity, exerts a pressure of one atmosphere; consequently, if 0.080728 lb. of air and 0.12344 lb. of carbonic acid, mixed, be inclosed at the temperature of 32°, in a vessel of one cubic foot of capacity, the mixture will exert a pressure of two atmospheres. As a second example: Let 0.080728 lb. of air, at 212°, be inclosed in a vessel of one cubic foot; it will exert a pressure of

$$\frac{212 + 459.2}{32 + 459.2} = 1.366 \text{ atmospheres.}$$

Let 0.03797 lb. of steam, at 212°, be inclosed in a vessel of one cubic foot; it will exert a pressure of one atmosphere. Consequently, if 0.080728 lb. of air and 0.03797 lb. of steam be mixed and inclosed together, at 212°, in a vessel of one cubic foot, the mixture will exert a pressure of 2.366 atmospheres. It is a common but erroneous practice, in elementary books on physics, to describe this law as constituting a difference between mixed and homogeneous gases; whereas it is obvious that for mixed and homogeneous gases the law of pressure is exactly the same, viz., that the pressure of the whole of a gaseous mass is the sum of the pressures of all its parts. This is one of the laws of mixture of gases and vapors.

A second law is that the presence of a foreign gaseous substance in contact with the surface of a solid or liquid does not affect the density of the vapor of that solid or liquid unless there is a tendency to chemical combination between the two substances, in which case the density of the vapor is slightly increased. (Rankine, S. E., p. 239.)

If 0.0591 lb. of air, = 1 cu. ft. at 212° and atmospheric pressure, is contained in a vessel of 1 cu. ft. capacity, and water at 212° is introduced, heat at 212° being furnished by a steam jacket, the pressure will rise to two atmospheres.

If air is present in a condenser along with water vapor, the pressure is that due to the temperature of the vapor plus that due to the quantity of air present.

**Flow of Gases.** — By the principle of the conservation of energy, it may be shown that the velocity with which a gas under pressure will escape into a vacuum is inversely proportional to the square root of its density; that is, oxygen, which is sixteen times as heavy as hydrogen, would, under exactly the same circumstances, escape through an opening only one fourth as fast as the latter gas.

**Absorption of Gases by Liquids.** — Many gases are readily absorbed by water. Other liquids also possess this power in a greater or less degree. Water will, for example, absorb its own volume of carbonic-acid gas, 800 times its volume of ammonia,  $2\frac{1}{3}$  times its volume of chlorine, and only about  $\frac{1}{20}$  of its volume of oxygen.

The weight of gas that is absorbed by a given volume of liquid is proportional to the pressure. But as the volume of a mass of gas is less as the pressure is greater, the volume which a given amount of liquid can absorb at a certain temperature will be constant, whatever the pressure. Water, for example, can absorb its own volume of carbonic-acid gas at atmospheric pressure; it will also dissolve its own volume if the pressure is twice as great, but in that case the gas will be twice as dense, and consequently twice the weight of gas is dissolved.

**Liquefaction of Gases.—Liquid Air.** (A. L. Rice, *Trans. A. S. M. E.*, xxi, 156.)—Oxygen was first liquefied in 1877 by Cailletet and Pictet, working independently. In 1884 Dewar liquefied air, and in 1898 he liquefied hydrogen at a temperature of  $-396.4^{\circ}$  F., or only  $65^{\circ}$  above the absolute zero. The method of obtaining the low temperatures required for liquefying gases was suggested by Sir W. Siemens, in 1857. It consists in expanding a compressed gas in a cylinder doing work, or through a small orifice, to a lower pressure, and using the cold gas thereby produced to cool, before expansion, the gas coming to the apparatus. Hampson claims to have condensed about 1.2 quarts of liquid air per hour at an

expenditure of 3.5 H.P. for compression, using a pressure of 120 atmospheres expanded to 1, and getting 6.6 per cent of the air handled as liquid.

The following table gives some physical constants of the principal gases that have been liquefied. The critical temperature is that at which the properties of a liquid and its vapor are indistinguishable, and above which the vapor cannot be liquefied by compression. The critical pressure is the pressure of the vapor at the critical temperature.

		Critical Temp. Deg. F.	Critical Pressure in Atmospheres	Temp. of Saturated Vapor at Atmos. Pressure Deg. F.	Freezing Point. Deg. F.	Density of Liquid at Temperature Given.
Water.....	H <sub>2</sub> O	689	200	212	32	1 at 39° F.
Ammonia.....	NH <sub>3</sub>	266	115	-27	-107	0.6364 at 32° F.
Acetylene.....	C <sub>2</sub> H <sub>2</sub>	98.6	.....	-121	-113.8	.....
Carbon Dioxide....	CO <sub>2</sub>	88	75	-112	-69	0.83 at 32° F.
Ethylene.....	C <sub>2</sub> H <sub>4</sub>	50	51.7	-150	-272	.....
Methane.....	CH <sub>4</sub>	-115.2	54.9	-263.4	-302.4	{ 0.415 at -263° F. }
Oxygen.....	O <sub>2</sub>	-182	50.8	-294.5	.....	{ 1.124 at -294° F. }
Argon.....	A	-185.8	50.6	-304.6	-309.3	{ about 1.5 at -305° F. }
Carbon Monoxide..	CO	-219.1	35.5	-310	-340.6	.....
Air.....	.....	-220	39	-312.6	.....	{ 0.933 at -313° F. }
Nitrogen.....	N <sub>2</sub>	-231	35	-318	-353.2	{ 0.885 at -318° F. }
Hydrogen.....	H <sub>2</sub>	-389	20	-405	.....	.....

### AIR.

**Properties of Air.** — Air is a mechanical mixture of the gases oxygen and nitrogen, with about 1% by volume of argon. Atmospheric air of ordinary purity contains about 0.04% of carbon dioxide. The composition of air is variously given as follows:

	By Volume.			By Weight.		
	N	O	Ar	N	O	Ar
1.....	79.3	20.7	.....	77	23	.....
2.....	79.09	20.91	.....	76.85	23.15	.....
3.....	78.122	20.941	0.937	75.539	23.024	1.437
4.....	78.06	21.	0.94	75.5	23.2	1.3

(1) Values formerly given in works on physics. (2) Average results of several determinations, Hempel's Gas Analysis. (3) Sir. Wm. Ramsay, *Bull. U. S. Geol. Survey*, No. 330. (4) A. Leduc, *Comptes Rendus*, 1896, *Jour. F. I.*, Jan., 1898. Leduc gives for the density of oxygen relatively to air 1.10523; for nitrogen 0.9671; for argon, 1.376.

The weight of pure air at 32° F. and a barometric pressure of 29.92 inches of mercury, or 14.6963 lbs. per sq. in., or 2116.3 lbs. per sq. ft., is 0.080728 lb. per cubic foot. Volume of 1 lb. = 12.387 cu. ft. At any other temperature and barometric pressure its weight in lbs. per cubic foot is  $W = \frac{1.3253 \times B}{459.6 + T}$ , where  $B$  = height of the barometer,  $T$  = temperature Fahr., and 1.3253 = weight in lb. of 459.6 cu. ft. of air at 0° F. and one inch barometric pressure. Air expands 1/491.6 of its volume at

32° F. for every increase of 1° F., and its volume varies inversely as the pressure.

Conversion Table for Air Pressures.

	Lb. per Sq. Ft.	In. of Water.	Oz. per Sq. In.	Ft. of Water.	In. of Mercury.	Lb. per Sq. In.	Ft. of Air at 62° F.	$V = \sqrt{2gH}$ Ft. per Sec.
1 lb. per sq. ft. . .	1	0.19245	1/9	0.1604	0.01414	1/144	13.14	29.1
1 in. water at 62° F. . . . .	5.196	1	0.5774	1/12	0.07347	0.036085	68.30	66.3
1 oz. per sq. in. . .	9	1.732	1	0.1443	0.1272	1/16	118.3	87.2
1 ft. water at 62° F. . . . .	62.355	12	6.928	1	0.8816	0.43302	819.6	230
1 in. mercury at 32° F. . . . .	70.73	13.612	7.859	1.1343	1	0.49117	929.6	245
1 lb. per sq. in. . .	144	27.712	16	2.3094	2.036	1	1893	349
1 atmosphere. . . .	2116.3	407.27	.....	33.94	29.921	14.6963	27,815	1338
(1)	(2)	(3)	(4)	(5)	(6)	(7)	(8)	(9)

The figures in column (8) show the head in feet of air of uniform density at atmospheric pressure and 62° F. corresponding to the pressure in the preceding columns, and those in column (9) the theoretical velocities corresponding to these heads, or the velocities of a jet flowing from a frictionless conical orifice whose flow coefficient is unity.

**The Air-manometer** consists of a long, vertical glass tube, closed at the upper end, open at the lower end, containing air, provided with a scale, and immersed, along with a thermometer, in a transparent liquid, such as water or oil, contained in a strong cylinder of glass, which communicates with the vessel in which the pressure is to be ascertained. The scale shows the volume occupied by the air in the tube.

Let  $v_0$  be that volume, at the temperature of 32° Fahrenheit, and mean pressure of the atmosphere,  $p_0$ ; let  $v_1$  be the volume of the air at the temperature  $t$ , and under the absolute pressure to be measured  $p_1$ ; then

$$p_1 = \frac{(t + 459.6) p_0 v_0}{491.6 v_1}$$

### Pressure of the Atmosphere at Different Altitudes.

At the sea level the pressure of the air is 14.7 pounds per square inch; at 1/4 of a mile above the sea level it is 14.02 pounds; at 1/2 mile, 13.33; at 3/4 mile, 12.66; at 1 mile, 12.02; at 1 1/4 mile, 11.42; at 1 1/2 mile, 10.88; and at 2 miles, 9.80 pounds per square inch. For a rough approximation we may assume that the pressure decreases 1/2 pound per square inch for every 1000 feet of ascent. (See table, p. 608.)

It is calculated that at a height of about 3 1/2 miles above the sea level the weight of a cubic foot of air is only one-half what it is at the surface of the earth, at seven miles only one-fourth, at fourteen miles only one-sixteenth, at twenty-one miles only one sixty-fourth, and at a height of over forty-five miles it becomes so attenuated as to have no appreciable weight.

The pressure of the atmosphere increases with the depth of shafts, equal to about one inch rise in the barometer for each 900 feet increase in depth; this may be taken as a rough-and-ready rule for ascertaining the depth of shafts.

**Leveling by the Barometer and by Boiling Water.** (Trautwine.) — Many circumstances combine to render the results of this kind of leveling unreliable where great accuracy is required. It is difficult to read off from an aneroid (the kind of barometer usually employed for engineering purposes) to within from two to five or six feet, depending on its size. The moisture or dryness of the air affects the results; also winds, the vicinity of mountains, and the daily atmospheric tides, which cause incessant and irregular fluctuations in the barometer. A barometer hanging quietly in a room will often vary 1/10 of an inch within a few



hours, corresponding to a difference of elevation of nearly 100 feet. No formula can be devised that shall embrace these sources of error.

**Boiling Point of Water.**—Temperature in degrees F., barometer in in. of mercury.

In.	.0	.1	.2	.3	.4	.5	.6	.7	.8	.9
28	208.7	208.9	209.1	209.2	209.4	209.5	209.7	209.9	210.1	210.3
29	210.5	210.6	210.8	210.9	211.1	211.3	211.4	211.6	211.8	212.0
30	212.1	212.3	212.4	212.6	212.8	212.9	213.1	213.3	213.5	213.6

**To Find the Difference in Altitude of Two Places.**—Take from the table the altitudes opposite to the two boiling temperatures, or to the two barometer readings. Subtract the one opposite the lower reading from that opposite the upper reading. The remainder will be the required height, as a rough approximation. To correct this, add together the two thermometer readings, and divide the sum by 2, for their mean. From table of corrections for temperature, take the number under this mean. Multiply the approximate height just found by this number.

At 70° F. pure water will boil at 1° less of temperature for an average of about 550 feet of elevation above sea level, up to a height of 1/2 a mile. At the height of 1 mile, 1° of boiling temperature will correspond to about 560 feet of elevation. In the table the mean of the temperatures at the two stations is assumed to be 32° F., at which no correction for temperature is necessary in using the table.

Boiling-point in Deg. Fahr.	Barom., In.	Altitude above Sea level, Feet.	Boiling-point in Deg. Fahr.	Barom., In.	Altitude above Sea level, Feet.	Boiling-point in Deg. Fahr.	Barom., In.	Altitude above Sea level, Feet.
184°	16.79	15,221	196	21.71	8,481	208	27.73	2,063
185	17.16	14,649	197	22.17	7,932	208.5	28.00	1,809
186	17.54	14,075	198	22.64	7,381	209	28.29	1,539
187	17.93	13,498	199	23.11	6,843	209.5	28.56	1,290
188	18.32	12,934	200	23.59	6,304	210	28.85	1,025
189	18.72	12,367	201	24.08	5,764	210.5	29.15	754
190	19.13	11,799	202	24.58	5,225	211	29.42	512
191	19.54	11,243	203	25.08	4,697	211.5	29.71	255
192	19.96	10,685	204	25.59	4,169	212	30.00	S.L. = 0
193	20.39	10,127	205	26.11	3,642	212.5	30.30	—261
194	20.82	9,579	206	26.64	3,115	213	30.59	—511
195	21.26	9,031	207	27.18	2,589	.....	.....	.....

#### CORRECTIONS FOR TEMPERATURE.

Mean temp. F. in shade	0	10°	20°	30°	40°	50°	60°	70°	80°	90°	100°
Multiply by	.933	.954	.975	.996	1.016	1.036	1.058	1.079	1.100	1.121	1.142

#### Pressure of the Atmosphere per Square Inch and per Square Foot at Various Readings of the Barometer.

☐ RULE.—Barometer in inches  $\times$  0.4916 = pressure per square inch; pressure per square inch  $\times$  144 = pressure per square foot.

Barometer.	Pressure per Sq. In.	Pressure per Sq. Ft.	Barometer.	Pressure per Sq. In.	Pressure per Sq. Ft.
In.	Lb.	Lb.*	In.	Lb.	Lb.*
28.00	13.75	1980	29.75	14.61	2104
28.25	13.88	1998	30.00	14.73	2122
28.50	14.00	2016	30.25	14.86	2140
28.75	14.12	2033	30.50	14.98	2157
29.00	14.24	2051	30.75	15.10	2175
29.25	14.37	2069	31.00	15.23	2193
29.50	14.49	2086			

\* Decimals omitted.

For lower pressures see table of the Properties of Steam

**Barometric Readings corresponding with Different Altitudes, in French and English Measures.**

Altitude.	Reading of Barometer.	Altitude.	Reading of Barometer.	Altitude.	Reading of Barometer.	Altitude.	Reading of Barometer.
meters	mm.	feet.	inches.	meters.	mm.	feet.	inches.
0	762	0.	30.	1147	660	3763.2	25.98
21	760	68.9	29.92	1269	650	4163.3	25.59
127	750	416.7	29.52	1393	640	4568.3	25.19
234	740	767.7	29.13	1519	630	4983.1	24.80
342	730	1122.1	28.74	1647	620	5403.2	24.41
453	720	1486.2	28.35	1777	610	5830.2	24.01
564	710	1850.4	27.95	1909	600	6243.	23.62
678	700	2224.5	27.55	2043	590	6702.9	23.22
793	690	2599.7	27.16	2180	580	7152.4	22.83
909	680	2962.1	26.77	2318	570	7605.1	22.44
1027	670	3369.5	26.38	2460	560	8071.	22.04

**Weight of Air per Cubic Foot at Different Pressures and Temperatures.**

$$\text{Formula: } W = 0.080728 \times \frac{P}{14.6963} \times \frac{491.6}{T + 459.6}$$

Temperature		Gage.	1	2	5	10	20	40	60	80	100	120
Deg. F.	Ab.	P = 14.6963	P = 15.696	P = 16.696	P = 19.696	P = 24.696	P = 34.696	P = 54.696	P = 74.696	P = 94.696	P = 114.696	P = 134.696
0	459.6	.086349	.09222	.09810	.11573	.14511	.20385	.32137	.43888	.55639	.67391	.79141
32	491.6	.080728	.08622	.09171	.10819	.13566	.19059	.30045	.41031	.52017	.63004	.73990
42	501.6	.079119	.08450	.08989	.10604	.13295	.18679	.29446	.40213	.50980	.61748	.72515
52	511.6	.077572	.08285	.08813	.10396	.13035	.18314	.28871	.39427	.49984	.60541	.71097
62	521.6	.076085	.08126	.08644	.10197	.12786	.17963	.28317	.38671	.49026	.59380	.69734
70	529.6	.074936	.08004	.08513	.10043	.12592	.17691	.27887	.38087	.48285	.58483	.68681
80	539.6	.073547	.07855	.08356	.09857	.12359	.17364	.27372	.37381	.47390	.57399	.67408
90	549.6	.072209	.07712	.08204	.09678	.12134	.17048	.26874	.36701	.46528	.56355	.66182
100	559.6	.070918	.07574	.08057	.09504	.11937	.16743	.26394	.36045	.45697	.55348	.64999
120	579.6	.068471	.07313	.07779	.09177	.11506	.16165	.25483	.34802	.44120	.53438	.62756
140	599.6	.066187	.07069	.07519	.08871	.11122	.15626	.24633	.33641	.42648	.51656	.60663
160	619.6	.064051	.06841	.07277	.08584	.10763	.15122	.23838	.32555	.41272	.49988	.58705
180	639.6	.062048	.06627	.07049	.08316	.10427	.14649	.23093	.31537	.39981	.48425	.56869
200	659.6	.060167	.06426	.06835	.08064	.10111	.14205	.22393	.30581	.38769	.46957	.55145
250	709.6	.055927	.05973	.06354	.07496	.09398	.13204	.20815	.28426	.36037	.43649	.51259
300	759.6	.052245	.05580	.05936	.07002	.08779	.12335	.19445	.26555	.33665	.40775	.47885
350	809.6	.049019	.05236	.05569	.06570	.08237	.11573	.18244	.24915	.31586	.38257	.44925
400	859.6	.046168	.04931	.05245	.06188	.07758	.10900	.17183	.23466	.29748	.36032	.42314
450	909.6	.043630	.04660	.04957	.05847	.07332	.10301	.16238	.22176	.28113	.34051	.39988
500	959.6	.041357	.04417	.04699	.05543	.06950	.09764	.15392	.21020	.26648	.32277	.37905
550	1009.6	.039309	.04198	.04466	.05268	.06606	.09280	.14630	.19979	.25329	.30678	.36028
600	1059.6	.037454	.04000	.04255	.05020	.06294	.08842	.13939	.19037	.24133	.29230	.34327
650	1109.6	.035766	.03820	.04063	.04793	.06010	.08444	.13311	.18179	.23046	.27913	.32781
700	1159.6	.034224	.03655	.03888	.04587	.05751	.08080	.12737	.17395	.22052	.26710	.31367
800	1259.6	.031507	.03365	.03579	.04223	.05294	.07438	.11726	.16014	.20301	.24589	.28877
900	1359.6	.029190	.03118	.03316	.03912	.04905	.06891	.10864	.14836	.18808	.22781	.26753
1000	1459.6	.027190	.02904	.03089	.03644	.04569	.06419	.10119	.13830	.17519	.21220	.24920

**Moisture in the Atmosphere.** — Atmospheric air always contains a small quantity of carbonic acid (see Ventilation), and a varying quantity of aqueous vapor or moisture. The relative humidity of the air at any time is the percentage of moisture contained in it as compared with the amount it is capable of holding at the same temperature.

The degree of saturation or relative humidity of the air is determined by the use of the dry and wet bulb thermometer. The degree of saturation for a number of different readings of the thermometer is given in

the following table, condensed from the Hygrometric Tables of the U. S. Weather Bureau:

RELATIVE HUMIDITY, PER CENT.

Dry Ther- mometer, Deg. F.	Difference between the Dry and Wet Thermometers, Deg. F.																											
	1	2	3	4	5	6	7	8	9	10	11	12	13	14	15	16	17	18	19	20	21	22	23	24	26	28	30	
	Relative Humidity, Saturation being 100. (Barometer = 30 in.)																											
32	89	79	69	59	49	39	30	20	11	2																		
40	92	83	75	68	60	52	45	37	29	23	15	7	0															
50	93	87	80	74	67	61	55	49	43	38	32	27	21	16	11	5	0											
60	94	89	83	78	73	68	63	58	53	48	43	39	34	30	26	21	17	13	9	5	1							
70	95	90	86	81	77	72	68	64	59	55	51	48	44	40	36	33	29	25	22	19	15	12	9	6				
80	96	91	87	83	79	75	72	68	64	61	57	54	50	47	44	41	38	35	32	29	26	23	20	18	12	7		
90	96	92	89	85	81	78	74	71	68	65	61	58	55	52	49	47	44	41	39	36	34	31	29	26	22	17	13	
100	96	93	89	86	83	80	77	73	70	68	65	62	59	56	54	51	49	46	44	41	39	37	35	33	28	24	21	
110	97	93	90	87	84	81	78	75	73	70	67	65	62	60	57	55	52	50	48	46	44	42	40	38	34	30	26	
120	97	94	91	88	85	82	80	77	74	72	69	67	65	62	60	58	55	53	51	49	47	45	43	41	38	34	31	
140	97	95	92	89	87	84	82	79	77	75	73	70	68	66	64	62	60	58	56	54	53	51	49	47	44	41	38	

Mixtures of Air and Saturated Vapor.

(From Goodenough's Tables.)

Temp., ° F.	Pressure of Saturated Vapor.		Weight of Saturated Vapor.		Volume in Cu. Ft.		B.T.U. per Lb. Dry Air above 0° F.	Latent Heat of Vapor, B.T.U.	B.T.U. of 1 Lb. Dry Air with Vapor to Saturate It.
	In., Mercury.	Lb. per Sq. In.	Per Cu. Ft.	Per Lb. of Dry Air.	Of 1 Lb. Dry Air.	Of one lb. Dry Air + Vapor.			
0	0.0375	0.0184	0.0000674	0.000781	11.58	11.59	0.0	0.964	0.964
10	.0628	.0308	.0001103	.001309	11.83	11.86	2.411	1.608	4.019
20	.1027	.0504	.000177	.002144	12.09	12.13	4.823	2.623	7.446
32	.1806	.0887	.000303	.003782	12.39	12.47	7.716	4.058	11.783
35	.2036	.1000	.000340	.004268	12.47	12.55	8.44	4.57	13.02
40	.2478	.1217	.000410	.005202	12.59	12.70	9.65	5.56	15.21
45	.3003	.1475	.000492	.00632	12.72	12.85	10.86	6.73	17.59
50	.3624	.1780	.000588	.00764	12.84	13.00	12.07	8.12	20.19
55	.4356	.2140	.000699	.00920	12.97	13.16	13.28	9.76	23.04
60	.5214	.2561	.000829	.01105	13.10	13.33	14.48	11.69	26.18
65	.6218	.3054	.000979	.01323	13.22	13.50	15.69	13.96	29.65
70	.7386	.3628	.001153	.01578	13.35	13.69	16.90	16.61	33.51
75	.8744	.4295	.001352	.01877	13.48	13.88	18.11	19.71	37.81
80	1.0314	.5066	.001580	.02226	13.60	14.09	19.32	23.31	42.64
85	1.212	.5955	.001841	.02634	13.73	14.31	20.53	27.51	48.04
90	1.421	.6977	.002137	.03109	13.86	14.55	21.74	32.39	54.13
95	1.659	.8148	.002474	.03662	13.98	14.80	22.95	38.06	61.01
100	1.931	.9486	.002855	.04305	14.11	15.08	24.16	44.63	68.79
105	2.241	1.1010	.003285	.0505	14.24	15.39	25.37	52.26	77.63
110	2.594	1.274	.003769	.0593	14.36	15.73	26.58	61.11	87.69
115	2.994	1.470	.004312	.0694	14.49	16.10	27.79	71.40	99.10
120	3.444	1.692	.004920	.0813	14.62	16.52	29.00	83.37	112.37
130	4.523	2.221	.006356	.1114	14.88	17.53	31.42	113.64	145.06
140	5.878	2.887	.008130	.1532	15.13	18.84	33.85	155.37	189.22
150	7.566	3.716	.01030	.2122	15.39	20.60	36.27	214.03	250.3
160	9.649	4.739	.01294	.2987	15.64	23.09	38.69	299.55	338.2
170	12.20	5.990	.01611	.4324	15.90	26.84	41.12	431.2	472.3
180	15.29	7.51	.01991	.6577	16.16	33.04	43.55	651.9	695.5
190	19.01	9.34	.02441	1.0985	16.41	45.00	45.97	1082.3	1128.3
200	23.46	11.53	.02972	2.2953	16.67	77.24	48.40	2247.5	2296

Below 32° F. the pressure of saturated vapor in contact with ice is given. Values in the last column do not include the heat of the liquid. Below 32° F. the heat of sublimation of ice rather than the latent heat of vaporization is used.



**Moisture in Air at Different Pressures and Temperatures.** (H. M. Prevost Murphy, *Eng. News*, June 18, 1908.) — 1. The maximum amount of moisture that pure air can contain depends only on its temperature and pressure, and has an unvarying value for each condition.

2. The higher the temperature of the air, the greater is the amount of moisture that it can contain.

3. The higher the pressure of the air, the smaller is the amount of moisture that it can contain.

4. When air is compressed, the rise of temperature due to the compression, in all cases found in practice, far more than offsets the opposite effect of the rise of pressure on the moisture-carrying capacity of the air. Water is deposited, therefore, by compressed air as it passes from the compressor to the various portions of the system.

Suppose that a certain amount of atmospheric air enters a compressor and that it contains all the moisture possible at the existing outside temperature and pressure. As this air is compressed its moisture-carrying capacity rapidly increases, consequently all the moisture is retained by the air and passes with it into the main or storage reservoir. Now if this air is permitted to pass from the reservoir into the various parts of the system before being cooled to the outside temperature, it will carry more moisture than it is capable of holding when the temperature finally drops to the normal point, and this excess quantity will be deposited, because, the pressure being high, the air cannot hold as much moisture as it did at the same temperature and only atmospheric pressure.

In order to reduce the moisture to a minimum, it is desirable to cool the air to the outside temperature before it leaves the reservoir, thereby causing it to deposit all of its excess moisture, which may be easily removed by drain cocks.

Although compressed air may be properly dried before leaving the main reservoirs, some moisture may be temporarily deposited when the air is subsequently expanded to lower pressures, as its moisture-carrying capacity is usually affected more by the drop in temperature, resulting from the expansion, than by the drop in pressure, but when the air again attains the outside temperature, the moisture thus deposited will be re-absorbed if it is freely exposed to the compressed air.

In order to determine what percentage of moisture pure air can contain at various pressures and temperatures, to ascertain how low the "relative humidity" of the atmosphere must be in order that no water will be deposited in any part of a compressed-air system and also to find to what temperature air drawn from a saturated atmosphere must be cooled in order to cause the deposition of moisture to commence, the following formulæ and tables are used, based on Dalton's law of gaseous pressures, which may be stated as follows:

The total pressure exerted against the interior of a vessel by a given quantity of a mixed gas enclosed in it is the sum of the pressures which each of the component gases, or vapors, would exert separately if it were enclosed alone in a vessel of the same bulk, at the same temperature. [The derivation of the formulæ is given at length in the original paper.]

**Formulæ for the Weight, in Lbs., of 1 Cu. Ft. of Dry Air, of 1 Cu. Ft. of Saturated Steam or Water Vapor and the Maximum Weight of Water Vapor that 1 Lb. of Pure Air Can Carry at Any Pressure and Temperature.** (Copyright, 1908, by H. M. Prevost Murphy.)

The values  $K$  and  $H$  being given in the table for various temperatures,  $t$ , in Fahrenheit degrees, the formulæ are:

$$\text{Weight of 1 cu. ft. saturated steam} = \frac{1.325271 KH}{459.2 + t}$$

$H$  = elastic force or tension of water vapor or saturated steam, in in. of mercury corresponding to the temperature  $t$  (Fahr.) =  $2.036 \times$  (gauge pressure + atmospheric pressure, in pounds per square inch).

$K$  = the ratio of the weight of a volume of saturated steam to an equal volume of pure dry air at the same temperature and pressure,

$$= 0.6113 + \frac{0.092 t}{850 - t}$$

Values of  $K$  and  $H$  corresponding to the various temperatures  $t$  are given in the table on p. 612.

$$\text{Weight of 1 cu. ft. pure dry air} = \frac{1.325271 M}{459.2 + t} = \frac{2.698192 P}{459.2 + t}$$

$M$  = absolute pressure in inches of mercury.

$P$  = absolute pressure in pounds per square inch.

$W$  = maximum weight, in lbs., of water vapor, that 1 lb. of pure air can contain, when the temperature of the mixture is  $t$ , and the total, or observed, absolute pressure in pounds per square inch is  $P$ .

$$= \frac{KH}{2.036 P - H}$$

NOTE.—The results obtained by the use of any of the above formulæ agree exactly with the average data for air and steam weights as given by the most reliable authorities and careful experiments, for all pressures and temperatures; the value of  $K$  being correct for all temperatures up to the critical steam temperature of 689° F.

VALUES OF "K" AND "H" CORRESPONDING TO TEMPERATURES  $t$  FROM - 30° TO 434° F.

$t$	$K$	$H$	$t$	$K$	$H$	$t$	$K$	$H$	$t$	$K$	$H$	$t$	$K$	$H$
-30	.6082	.0099	64	.6188	.5962	158	.6323	9.177	252	.6501	62.97	344	.6739	254.2
-28	.6084	.0111	66	.6190	.6393	160	.6326	9.628	254	.6505	65.21	346	.6745	261.0
-26	.6086	.0123	68	.6193	.6848	162	.6330	10.10	256	.6510	67.49	348	.6751	268.0
-24	.6088	.0137	70	.6196	.7332	164	.6333	10.59	258	.6514	69.85	350	.6757	275.0
-22	.6090	.0152	72	.6198	.7846	166	.6336	11.10	260	.6518	72.26	352	.6763	282.2
-20	.6092	.0168	74	.6201	.8391	168	.6340	11.63	262	.6523	74.75	354	.6770	289.6
-18	.6094	.0186	76	.6203	.8969	170	.6343	12.18	264	.6528	77.30	356	.6776	297.1
-16	.6096	.0206	78	.6206	.9585	172	.6346	12.75	266	.6532	79.93	358	.6783	304.8
-14	.6098	.0227	80	.6209	1.024	174	.6350	13.34	268	.6537	82.62	360	.6789	312.6
-12	.6100	.0250	82	.6211	1.092	176	.6353	13.96	270	.6541	85.39	362	.6795	320.6
-10	.6102	.0275	84	.6214	1.165	178	.6357	14.60	272	.6546	88.26	364	.6803	328.7
- 8	.6104	.0303	86	.6217	1.242	180	.6360	15.27	274	.6551	91.18	366	.6809	337.0
- 6	.6107	.0332	88	.6219	1.324	182	.6364	15.97	276	.6555	94.18	368	.6816	345.4
- 4	.6109	.0365	90	.6222	1.410	184	.6367	16.68	278	.6560	97.26	370	.6822	354.0
- 2	.6111	.0400	92	.6225	1.501	186	.6371	17.43	280	.6565	100.4	372	.6829	362.8
0	.6113	.0439	94	.6227	1.597	188	.6374	18.20	282	.6570	103.7	374	.6836	371.8
2	.6115	.0481	96	.6230	1.698	190	.6377	19.00	284	.6575	107.0	376	.6843	380.9
4	.6117	.0526	98	.6233	1.805	192	.6381	19.83	286	.6580	110.4	378	.6850	390.2
6	.6120	.0576	100	.6236	1.918	194	.6385	20.69	288	.6584	113.9	380	.6857	399.6
8	.6122	.0630	102	.6238	2.036	196	.6389	21.58	290	.6590	117.5	382	.6865	409.3
10	.6124	.0690	104	.6241	2.161	198	.6393	22.50	292	.6594	121.2	384	.6871	419.1
12	.6126	.0754	106	.6244	2.294	200	.6396	23.46	294	.6600	125.0	386	.6879	429.1
14	.6128	.0824	108	.6247	2.432	202	.6400	24.44	296	.6604	128.8	388	.6886	439.3
16	.6131	.0900	110	.6250	2.578	204	.6404	25.47	298	.6610	132.8	390	.6893	449.6
18	.6133	.0983	112	.6253	2.731	206	.6407	26.53	300	.6615	136.8	392	.6901	460.2
20	.6135	.1074	114	.6256	2.892	208	.6411	27.62	302	.6620	141.0	394	.6908	470.9
22	.6137	.1172	116	.6258	3.061	210	.6415	28.75	304	.6625	145.3	396	.6915	481.9
24	.6140	.1279	118	.6261	3.239	212	.6419	29.92	306	.6631	149.6	398	.6923	493.0
26	.6142	.1396	120	.6264	3.425	214	.6423	31.14	308	.6636	154.1	400	.6931	504.4
28	.6144	.1523	122	.6267	3.621	216	.6426	32.38	310	.6641	158.7	402	.6939	515.9
30	.6147	.1661	124	.6270	3.826	218	.6430	33.67	312	.6647	163.3	404	.6947	527.6
32	.6149	.1811	126	.6273	4.042	220	.6434	35.01	314	.6652	168.1	406	.6955	539.5
34	.6151	.1960	128	.6276	4.267	222	.6438	36.38	316	.6658	173.0	408	.6962	551.6
36	.6154	.2120	130	.6279	4.503	224	.6442	37.80	318	.6663	178.0	410	.6970	564.0
38	.6156	.2292	132	.6282	4.750	226	.6446	39.27	320	.6669	183.1	412	.6979	576.5
40	.6158	.2476	134	.6285	5.008	228	.6451	40.78	322	.6674	188.3	414	.6987	589.3
42	.6161	.2673	136	.6288	5.280	230	.6455	42.34	324	.6680	193.7	416	.6995	602.2
44	.6163	.2883	138	.6291	5.563	232	.6458	43.95	326	.6686	199.2	418	.7003	615.4
46	.6166	.3109	140	.6294	5.859	234	.6463	45.61	328	.6691	204.8	420	.7012	628.8
48	.6168	.3350	142	.6298	6.167	236	.6467	47.32	330	.6697	210.5	422	.7021	642.5
50	.6170	.3608	144	.6301	6.490	238	.6471	49.08	332	.6703	216.4	424	.7029	656.3
52	.6173	.3883	146	.6304	6.827	240	.6475	50.89	334	.6709	222.4	426	.7037	670.4
54	.6175	.4176	148	.6307	7.178	242	.6479	52.77	336	.6715	228.5	428	.7046	684.7
56	.6178	.4490	150	.6310	7.545	244	.6484	54.69	338	.6721	234.7	430	.7055	699.2
58	.6180	.4824	152	.6313	7.929	246	.6488	56.67	340	.6727	241.1	432	.7064	713.9
60	.6183	.5180	154	.6317	8.328	248	.6492	58.71	342	.6733	247.6	434	.7073	728.9
62	.6185	.5559	156	.6320	8.744	250	.6496	60.81						

**Weights in Pounds, of Pure Dry Air, Water Vapor and Saturated Mixtures of Air and Water Vapor at Various Temperatures, at Atmospheric Pressure, 29.921 In. of Mercury or 14.6963 Lb. per Sq. In. Also the Elastic Force or Pressure of the Air and Vapor Present in Saturated Mixtures.**

(Copyright, 1908, by H. M. Prevost Murphy.)

Temperatures in Fahrenheit Degrees.	Weight of One Cubic Foot of Pure Dry Air, Lb.	Saturated Mixtures of Air and Water Vapor.					
		Elastic Force of the Vapor, In. of Mercury.	Elastic Force of the Air alone, when Saturated, Ins. of Mercury.	Weight of the Vapor in 1 Cu. Ft. of the Mixture, or Wt. of 1 Cu. Ft. of Saturated Steam.	Weight of the Air in 1 Cu. Ft. of the Mixture.	Total Weight of 1 Cu. Ft. of the Mixture.	Weight of Water Vapor Mixed with 1 lb. of Air.
0	0.086354	0.0439	29.877	0.000077	0.086226	0.086303	0.000898
12	0.084154	0.0754	29.846	0.000130	0.083943	0.084073	0.001548
22	0.082405	0.1172	29.804	0.000198	0.082083	0.082281	0.002413
32	0.080728	0.1811	29.740	0.000300	0.080239	0.080539	0.003744
42	0.079117	0.2673	29.654	0.000435	0.078411	0.078846	0.005554
52	0.077569	0.3883	29.533	0.000621	0.076563	0.077184	0.008116
62	0.076081	0.5559	29.365	0.000874	0.074667	0.075541	0.011709
72	0.074649	0.7846	29.136	0.001213	0.072690	0.073903	0.016691
82	0.073270	1.092	28.829	0.001661	0.070595	0.072256	0.023526
92	0.071940	1.501	28.420	0.002247	0.068331	0.070578	0.032877
102	0.070658	2.036	27.885	0.002999	0.065850	0.068849	0.045546
112	0.069421	2.731	27.190	0.003962	0.063085	0.067047	0.062806
122	0.068227	3.621	26.300	0.005175	0.059970	0.065145	0.086285
132	0.067073	4.750	25.171	0.006689	0.056425	0.063114	0.118548
142	0.065957	6.167	23.754	0.008562	0.052363	0.060925	0.163508
152	0.064878	7.929	21.992	0.010854	0.047686	0.058540	0.227609
162	0.063834	10.097	19.824	0.013636	0.042293	0.055929	0.322407
172	0.062822	12.749	17.172	0.016987	0.036055	0.053042	0.471146
182	0.061843	15.965	13.956	0.021000	0.028845	0.049845	0.728012
192	0.060893	19.826	10.095	0.025746	0.020545	0.046291	1.25319
202	0.059972	24.442	5.479	0.031354	0.010982	0.042336	2.85507
212	0.059079	29.921	0.000	0.037922	0.000000	0.037922	Infinite

**Applications of the Formulæ and Tables.**

**EXAMPLE 1.**—How low must the relative humidity be, when the atmospheric pressure is 14.7 lb. per sq. in. and the outside temperature is 60°, in order that no moisture may be deposited in any part of a compressed air system carrying a constant gauge pressure of 90 lb. per sq. in?

*Ans.*—The maximum amount of moisture that 1 lb. of pure air can contain at 90 lb. gauge, = 104.7 lb. (absolute pressure) and 60° F., is

$$W = \frac{KH}{2.036 P - H} = \frac{0.6183 \times 0.5180}{2.036 \times 104.7 - 0.5180} = 0.001506 \text{ lb.}$$

The maximum weight of moisture that 1 lb. of air can contain at 60° F. and 14.7 lb. (absolute pressure) is

$$W \text{ (at 14.7)} = \frac{0.618 \times 0.5180}{2.036 \times 14.7 - 0.5180} = 0.01089 \text{ lb.}$$

In order that no moisture may be deposited, the relative humidity must not be above

$$(0.001506 \div 0.01089) \times 100 = 13.83 \%$$

**NOTE.**—Air is said to be saturated with water vapor when it contains the maximum amount possible at the existing temperature and pressure.

**EXAMPLE 2.**—When compressing air into a reservoir carrying a constant gauge pressure of 75 lb., from a saturated atmosphere of 14.7 lb. abs. press. and 70° F., to what temperature must the air be cooled after compression in order to cause the deposition of moisture to commence?

*Ans.*—First find the maximum weight of moisture contained in 1 lb. of pure air at 14.7 lb. pressure and 70° F.



$$W = \frac{KH}{2.036 P - H} = \frac{0.6196 \times 0.7332}{2.036 \times 14.7 - 0.7332} = 0.01556 \text{ lb.}$$

The temperature to which the air must be cooled in order to cause the deposition of moisture may be found by placing this value of 0.01556 together with  $P$  equal to  $75 + 14.7$  in the equation thus:

$$0.01556 = \frac{KH}{2.036 \times 89.7 - H} = \frac{KH}{182.63 - H}$$

or  $H = \frac{2.842}{0.01556 + K}$ , and the temperature which satisfies this equation is found by aid of the table [by trial and error] to be approximately  $129^\circ \text{ F.}$

**EXAMPLE 3.** — When the outside temperature is  $82^\circ \text{ F.}$ , and the pressure of the atmosphere is 14.6963 lb. per sq. in., the relative humidity being 100%, how many cu. ft. of free air must be compressed and delivered into a reservoir at 100 lb. gauge in order to cause 1 lb. of water to be deposited when the air is cooled to  $82^\circ \text{ F.}$ ?

*Ans.* — Weight of moisture mixed with 1 lb. of air at  $82^\circ \text{ F.}$ , and atmospheric pressure = 0.023526 lb. For 100 lb. gauge pressure,

$$W = \frac{KH}{2.036 P - H} = \frac{0.6211 \times 1.092}{2.036 \times 114.6963 - 1.092} = 0.002918 \text{ lb.}$$

Weight of moisture deposited by each lb. of compressed air =  $0.023526 - 0.002918 = 0.020608$  lb. Each cu. ft. of the moist atmosphere contains 0.070595 lb. of pure air, therefore the number of cu. ft. that must be delivered to cause 1 lb. of water to be deposited is

$$\frac{1}{0.070595} \times \frac{1}{0.020608} = 687.37 \text{ cu. ft.}$$

**EXAMPLE 4.** — Under the same conditions as stated in Example 3, what is the loss in volumetric efficiency of the plant when the excess moisture is properly trapped in the main reservoirs?

*Ans.* — Before compression, each pound of air is mixed with 0.023526 lb. of water vapor and the weight of 1 cu. ft. of the mixture is 0.072256 lb., consequently the volume of the mixture is

$$1.023526 \div 0.072256 = 14.165 \text{ cu. ft.}$$

For 100 lb. gauge pressure and  $82^\circ \text{ F.}$  as shown in Example 3, 1 lb. of air can hold 0.002918 lb. of water in suspension, having deposited 0.020608 lb. in the reservoir. The weight of 1 cu. ft. of water vapor at  $82^\circ$  is 0.001661 lb., consequently by Dalton's law the volume of the mixture of 1 lb. of air and 0.002918 lb. of water vapor at 100 lb. gauge pressure is the same as that of the vapor or saturated steam alone; that is,

$$0.002918 \div 0.001661 = 1.757 \text{ cu. ft.}$$

By Mariotte's law, the volume of the 1.757 cu. ft. of mixed gas at 114.6963 lb. absolute when expanded to atmospheric pressure will be

$$(114.6963 \div 14.6963) \times 1.757 = 13.712 \text{ cu. ft.};$$

consequently the decrease of volume, that is, the loss of volumetric efficiency, is

$$14.165 - 13.712 = 0.453 \text{ cu. ft.}, \text{ or } (0.453 \div 14.165) \times 100 = 3.2\%.$$

This example shows that, particularly in warm, moist climates, there is a very appreciable loss in the efficiency of compressors, due to the condensation of water vapor.

#### Specific Heat of Air at Constant Volume and at Constant Pressure.

— Volume of 1 lb. of air at  $32^\circ \text{ F.}$  and pressure of 14.7 lbs. per sq. in. = 12.387 cu. ft. = a column 1 sq. ft. area  $\times$  12.387 ft. high. Raising temperature  $1^\circ \text{ F.}$  expands it  $1/492$ , or to 12.4122 ft. high, a rise of 0.02522 ft.

Work done = 2116 lbs. per sq. ft.  $\times$  .02522 = 53.37 foot-pounds, or  $53.37 \div 778 = 0.0686$  heat units.

The specific heat of air at constant pressure, according to Regnault, is 0.2375; but this includes the work of expansion, or 0.0686 heat units; hence the specific heat at constant volume =  $0.2375 - 0.0686 = 0.1689$ .

Ratio of specific heat at constant pressure to specific heat at constant volume =  $0.2375 \div 0.1689 = 1.406$ . (See Specific Heat, p. 562.)

**Flow of Air through Orifices.** — The theoretical velocity in feet per second of flow of any fluid, liquid, or gas through an orifice is  $v = \sqrt{2gh} = 8.02 \sqrt{h}$ , in which  $h$  = the "head" or height of the fluid in feet required to produce the pressure of the fluid at the level of the orifice. (For gases the formula holds good only for small difference of pressure on the two sides of the orifice.) The quantity of flow in cubic feet per second is equal to the product of this velocity by the area of the orifice, in square feet, multiplied by a "coefficient of flow," which takes into account the contraction of the vein or flowing stream, the friction of the orifice, etc.

For air flowing through an orifice or short tube, from a reservoir of the pressure  $p_1$  into a reservoir of the pressure  $p_2$ , Weisbach gives the following values for the coefficient of flow, obtained from his experiments.

FLOW OF AIR THROUGH AN ORIFICE.

Coefficient  $c$  in formula  $v = c \sqrt{2gh}$

Diam. 1 cm. = 0.394 in.:						
Ratio of pressures...	1.05	1.09	1.43	1.65	1.89	2.15
Coefficient.....	.555	.589	.692	.724	.754	.788
Diam. 2.14 cm. = 0.843 in.:						
Ratio of pressures...	1.05	1.09	1.36	1.67	2.01	....
Coefficient.....	.558	.573	.634	.678	.723	....

FLOW OF AIR THROUGH A SHORT TUBE.

Diam. 1 cm., = 0.394 in., length 3 cm. = 1.181 in.						
Ratio of pressures $p_1 \div p_2$ ...	1.05	1.10	1.30	....	....	....
Coefficient.....	.730	.771	.830	....	....	....
Diam. 1.414 cm. = 0.557 in., length 4.242 cm. = 1.670 in.:						
Ratio of pressures.....	1.41	1.69	....	....	....	....
Coefficient.....	.813	.822	....	....	....	....
Diam. 1 cm. = 0.394 in., length 1.6 cm. = 0.630 in. Orifice rounded:						
Ratio of pressures.....	1.24	1.38	1.59	1.85	2.14	....
Coefficient.....	.979	.986	.965	.971	.978	....

Clark (Rules, Tables, and Data, p. 891) gives, for the velocity of flow of air through an orifice due to small differences of pressure,

$$V = C \sqrt{\frac{2gh}{12} \times 773.2 \times \left(1 + \frac{t - 32}{493}\right) \times \frac{29.92}{p}}$$

in which  $V$  = velocity in feet per second;  $2g = 64.4$ ;  $h$  = height of the column of water in inches, measuring the difference of pressure;  $t$  = the temperature Fahr.; and  $p$  = barometric pressure in inches of mercury. 773.2 is the volume of air at 32° under a pressure of 29.92 inches of mercury when that of an equal weight of water is taken as 1.

For 62° F., the formula becomes  $V = 363 C \sqrt{h/p}$ , and if  $p = 29.92$  inches,  $V = 66.35 C \sqrt{h}$ .

The coefficient of efflux  $C$ , according to Weisbach, is:

For conoidal mouthpiece, of form of the contracted vein,	
with pressures of from 0.23 to 1.1 atmospheres....	$C = 0.97$ to $0.99$
Circular orifices in thin plates.....	$C = 0.56$ to $0.79$
Short cylindrical mouthpieces.....	$C = 0.81$ to $0.84$
The same rounded at the inner end.....	$C = 0.92$ to $0.93$
Conical converging mouthpieces.....	$C = 0.90$ to $0.99$

R. J. Durley, *Trans. A. S. M. E.*, xxvii, 193, gives the following:

The consideration of the adiabatic flow of a perfect gas through a frictionless orifice leads to the equation

$$W = A \sqrt{2g \frac{\gamma}{\gamma - 1} \cdot \frac{P_1}{V_1} \left[ \left(\frac{P_2}{P_1}\right)^{\frac{2}{\gamma}} - \left(\frac{P_2}{P_1}\right)^{\frac{\gamma + 1}{\gamma}} \right]} \dots (1)$$

$W$  = weight of gas discharged per second in pounds.

$A$  = area of cross section of jet in square feet.

$P_1$  = pressure inside orifice in pounds per square foot.

$P_2$  = pressure outside orifice.

$V_1$  = specific volume of gas inside orifice in cu. ft. per lb.

$\gamma$  = ratio of the specific heat at constant pressure to that at constant volume.

For air, where  $\gamma = 1.404$ , we have for a circular orifice of diameter  $d$  inches, the initial temperature of the air being  $60^\circ$  Fahr. (or  $521^\circ$  abs.),

$$W = 0.000491 d^2 P_1 \sqrt{\left(\frac{P_2}{P_1}\right)^{1.425} - \left(\frac{P_2}{P_1}\right)^{1.712}} \dots (2)$$

In practice the flow is not frictionless, nor is it perfectly adiabatic, and the amount of heat entering or leaving the gas is not known. Hence the weight actually discharged is to be found from the formulas by introducing a coefficient of discharge (generally less than unity) depending on the conditions of the experiment and on the construction of the particular form of orifice employed.

If we neglect the changes of density and temperature occurring as the air passes through the orifice, we may obtain a simpler though approximate formula for the ideal discharge:

$$W = 0.01369 d^2 \sqrt{\frac{iP}{T}} \dots (3)$$

in which  $d =$  diam. in inches,  $i =$  difference of pressures measured in inches of water,  $P =$  mean absolute pressure in lbs. per sq. ft., and  $T =$  absolute temperature on the Fahrenheit scale = degrees F. + 461. In the usual case, in which the discharge takes place into the atmosphere,  $P$  is approximately 2117 pounds per square foot and

$$W = 0.6299 d^2 \sqrt{\frac{i}{T}} \dots (4)$$

To obtain the actual discharge the values found by the formula are to be multiplied by an experimental coefficient  $C$ , values of which are given in the table below.

Up to a pressure of about 20 ins. of water (or 0.722 lbs. per sq. in.) above the atmospheric pressure, the results of formulæ (2) and (4) agree very closely. At higher differences of pressure divergence becomes noticeable.

They hold good only for orifices of the particular form experimented with, and bored in plates of the same thickness, viz.: iron plates 0.057 in. thick.

The experiments and curves plotted from them indicate that:—

(1) The coefficient for small orifices increases as the head increases, but at a lesser rate the larger the orifices, till for the 2-in. orifice it is almost constant. For orifices larger than 2 ins. it decreases as the head increases, and at a greater rate the larger the orifice.

(2) The coefficient decreases as the diameter of the orifice increases, and at a greater rate the higher the head.

(3) The coefficient does not change appreciably with temperature (between  $40^\circ$  and  $100^\circ$  F.).

(4) The coefficient (at heads under 6 ins.) is not appreciably affected by the size of the box in which the orifice is placed if the ratio of the areas of the box and orifice is at least 20 : 1.

MEAN DISCHARGE IN POUNDS PER SQUARE FOOT OF ORIFICE PER SECOND AS FOUND FROM EXPERIMENTS.

Diameter Orifice, Inches.	1-inch Head Discharge per Sq. Ft.	2-inch Head Discharge per Sq. Ft.	3-inch Head Discharge per Sq. Ft.	4-inch Head Discharge per Sq. Ft.	5-inch Head Discharge per Sq. Ft.
0.3125	3.060	4.336	5.395	6.188	7.024
0.5005	3.012	4.297	5.242	6.129	6.821
1.002	3.058	4.341	5.348	6.214	6.838
1.505	3.050	4.257	5.222	6.071	6.775
2.002	2.983	4.286	5.284	6.107	6.788
2.502	3.041	4.303	5.224	5.991	6.762
3.001	3.078	4.297	5.219	6.033	6.802
3.497	3.051	4.258	5.202	5.966	6.814
4.002	3.046	4.325	5.264	5.951	6.774
4.506	3.075	4.383	5.508	6.260	7.028



COEFFICIENTS OF DISCHARGE FOR VARIOUS HEADS AND DIAMETERS OF ORIFICE.

Diameter of Orifice, Inches.	1-inch Head.	2-inch Head.	3-inch Head.	4-inch Head.	5-inch Head.
5/16	0.603	0.606	0.610	0.613	0.616
1/2	0.602	0.605	0.608	0.610	0.613
1	0.601	0.603	0.605	0.606	0.607
1 1/2	0.601	0.601	0.602	0.603	0.603
2	0.600	0.600	0.600	0.600	0.600
2 1/2	0.599	0.599	0.599	0.598	0.598
3	0.599	0.598	0.597	0.596	0.596
3 1/2	0.599	0.597	0.596	0.595	0.594
4	0.598	0.597	0.595	0.594	0.593
4 1/2	0.598	0.596	0.594	0.593	0.592

CORRECTED ACTUAL DISCHARGE IN POUNDS PER SECOND AT 60° F. AND 14.7 LBS. BAROMETRIC PRESSURE FOR CIRCULAR ORIFICES IN PLATE 0.057 IN. THICK.

Head, In. of Water.	Diameter of Orifice in Inches.										
	0.3125	0.500	1.000	1.500	2.000	2.500	3.000	3.500	4.000	4.500	5.000
1/2	0.00114	0.00293	0.0117	0.0263	0.0468	0.0732	0.105	0.143	0.187	0.237	0.292
1	0.00162	0.00416	0.0166	0.0373	0.0663	0.103	0.149	0.202	0.264	0.334	0.413
1 1/2	0.00199	0.00510	0.0203	0.0457	0.0811	0.127	0.182	0.248	0.323	0.409	0.505
2	0.00231	0.00590	0.0235	0.0528	0.0937	0.146	0.210	0.285	0.373	0.471	0.582
2 1/2	0.00259	0.00662	0.0263	0.1591	0.105	0.163	0.235	0.319	0.416	0.526	0.649
3	0.00285	0.00726	0.0289	0.0648	0.115	0.179	0.257	0.349	0.455	0.575	0.710
3 1/2	0.00308	0.00786	0.0312	0.0700	0.124	0.193	0.277	0.377	0.491	0.621	0.766
4	0.00330	0.00842	0.0334	0.0749	0.133	0.206	0.296	0.402	0.525	0.663	0.817
4 1/2	0.00351	0.00895	0.0355	0.0794	0.141	0.219	0.314	0.426	0.556	0.702	0.865
5	0.00371	0.00945	0.0375	0.0838	0.148	0.231	0.331	0.449	0.586	0.739	0.912
5 1/2	0.00390	0.00993	0.0393	0.0879	0.155	0.242	0.347	0.471	0.613	0.774	0.953
6	0.00408	0.01049	0.0411	0.0918	0.162	0.252	0.362	0.492	0.640	0.808	0.995

Fliegner's Equation for Flow of Air through an Orifice.—(Peabody's "Thermodynamics," also *Trans. A. S. M. E.*, vol. 27, p. 194.)

$$W = 0.53 A \frac{P}{\sqrt{T}}$$

$W$  = flow in pounds per second;  $A$  = area of the orifice (or sum of the areas of all the orifices) in square inches;  $P$  = absolute pressure in the orifice chamber lb. per sq. in.;  $T$  = absolute temperature, deg. F., of the air in the chamber. The formula applies only when the absolute pressure in the reservoir is greater than twice the atmospheric pressure, and for orifices properly made. The orifices are in hardened steel plates 3/8 in. to 1/2 in. thick, accurately ground, with the inside orifice rounded to a radius 1/16 in. less than the thickness of the plate, leaving 1/16 in. of the hole straight.

FLOW OF AIR IN PIPES.

In the steady flow of any liquid or gas, without friction, the sum of the velocity head,  $V^2 \div 2g$ , pressure head  $p/w$ , and potential head,  $z$ , (that is the distance in feet above an assumed datum) at any section of

the pipe is a constant quantity.  $\frac{V^2}{2g} + \frac{p}{w} + z = \text{a constant}$ . This statement is known as Bernoulli's theorem.

$V$  = velocity in ft. per sec.;  $2g = 64.35$ ;  $p$  = absolute pressure in pounds per square feet;  $w$  = density, pounds per cubic feet;  $z$  = height of the section above a given datum level. When the pipe is level we may take its axis as datum, and then  $z = 0$ .

When "fluid friction" or "skin friction" is taken into account there

is a "loss of head" or "friction head" between any two selected points, such as the two ends of the pipe,  $H = f L v^2 \div R 2 g$ ; or  $H = 4 f \frac{L}{D} \frac{v^2}{2g}$ ;

$H$  is the loss of head, or head causing the flow, measured in feet of the fluid,  $f$  is a coefficient of friction and  $R$  the mean hydraulic radius, which in circular pipes =  $\frac{1}{4} D$ .  $L$  is the length of the pipe and  $D$  the diameter, both in feet. By transposition the velocity in feet per

$$\text{second is } V = \sqrt{\frac{2g}{4f} \frac{H D}{L}} = 4.0103 \sqrt{\frac{H D}{f L}}.$$

The value of  $f$  in this formula varies through a considerable range with the roughness of the pipe, with the diameter, and probably to some extent with the velocity. For a rough approximation its value for air and other gases may be taken as 0.005.

For convenience in calculation, the loss of head in feet of  $H$  may be replaced by the difference in pressure in lb. per sq. in.,  $H = 144 (p_1 - p_2) \div W$ , and the diameter  $d$  may be taken in inches. We thus obtain

$$v = 4.0103 \sqrt{\frac{144(p_1 - p_2)}{f w L} \frac{d}{12}} = 13.892 \sqrt{\frac{1}{f}} \sqrt{\frac{(p_1 - p_2) d}{w L}}.$$

The quantity of flow in cubic feet per minute,  $Q = 60 A V$ .  $A$  being the area in sq. ft. =  $60 \times 0.7854 \times d^2 \div 144$ , whence we have (by multi-

$$\text{plying } 60 \times 0.7854 \times 13.89 \div 144), Q = 4.546 \sqrt{\frac{1}{f}} \times \sqrt{\frac{p_1 - p_2 d^5}{w L}} = c \sqrt{\frac{(p_1 - p_2) d^5}{w L}}$$

which is the common formula for flow of any liquid or gas when  $Q$  is in cubic feet per minute measured at the density  $w$  corresponding to the higher pressure  $p_1$ . To reduce this to the equivalent volume of "free air" at atmospheric pressure,  $Q_a = Q \times \frac{p_1}{14.7}$ .

The weight flowing per minute is  $Q w = W = c \sqrt{\frac{w(p_1 - p_2) d^5}{L}}$ . Values of  $c$  corresponding to different values of  $f$  are as follows:

$f \dots$	0.003	.0035	.004	.0045	.005	.0055	.006	.0065	.007	.0075
$c \dots$	83.0	76.9	71.9	67.8	64.3	61.3	58.7	56.4	54.7	52.4

The experimental data from which the values of  $c$  and  $f$  for air and gas may be determined are few in number and of doubtful accuracy. Probably the most reliable are those obtained by Stockalper at the St. Gothard tunnel. Unwin found from these data that the value of  $f$  varied with the diameter and that it might be expressed by the formula  $f = 0.0028 (1 + 3.6/d)$ ,  $d$  being taken in inches.

For $d =$	1	2	3	4	6	12	24	48 In.
$f =$	0.013	.0078	.0062	.0053	.0045	.0036	.0032	.0030
$c =$	40.0	51.3	57.9	62.3	67.9	75.3	80.1	82.8

Unwin's formula may be given the form  $Q = K \sqrt{\frac{(p_1 - p_2) d^5}{w L (1 + 3.6/d)}}$ , in which  $K = 4.546 \sqrt{1 \div .0028} = 85.9$ . This is practically the same as Babcock's formula for steam, in which  $f$  is taken at 0.0027, giving  $K = 87.5$ .

**Formulae for Flow with Large Drop in Pressure.**—The above formulæ are based on the assumption that the drop in pressure is small, and that, therefore, the density remains practically constant during the flow. When the drop is large the density decreases with the pressure and the velocity increases. Church ("Mechanics of Engineering," p. 791) and Unwin (*Ency. Brit.*, 11th ed., vol. xiv., p. 67), develop formulæ for compressible fluids with large drop of pressure and increasing velocity. The temperature is assumed to be constant, the heat generated by friction balancing the cooling due to the work done in expansion.

Church's formula:  $Q = 1/4 \pi d^2 \sqrt{\frac{g d}{4 f l} \frac{1}{w p} (p_1^2 - p_2^2)}$ .

Unwin's formula:  $V = \sqrt{\frac{g R T d}{4 f l} \frac{(p_1^2 - p_2^2)}{p_1^2}}$ .

$V$  = velocity, ft. per sec.;  $Q$  = volume, cu. ft. per sec. at the pressure  $p_1$ ;  $g = 32.2$ ;  $R$  = the constant in the formula  $PV = RT$  (see Thermodynamics) = 53.32 for air;  $d$  = diam., and  $L$  = length, in feet;  $p_1, p_2$  = absolute pressures in lb. per sq. ft.;  $w$  = density, lb. per cu. ft.;  $T$  = temperature  $F. + 459.6$ . The value of  $f$  is given by Church as from 0.004 to 0.005. Unwin makes it vary with the diameter as stated above.

These two formulæ give identical results when the value of  $f$  is taken the same in both, for  $RT/p_1^2 = 1 \div w p_1$ .

J. E. Johnson, Jr. (*Am. Mach.*, July 27, 1899) gives Church's formula in a simpler form as follows:  $p_1^2 - p_2^2 = K Q^2 L \div d^5$ , in which  $p_1$  and  $p_2$  are the initial and final pressures in lb. per sq. in.,  $Q$  the volume of free air (that is the volume reduced to atmospheric pressure) in cubic feet per minute,  $d$  the diameter of the pipe in inches,  $L$  the length in feet, and  $K$  a numerical coefficient which from the Mt. Ceniz and St. Gothard experiments has a value of about 0.0006. E. A. Rix, in a paper on the Compression and Transmission of Illuminating Gas, read before the Pacific Coast Gas Ass'n, 1905, says he uses Johnson's formula, with a coefficient of 0.0005, which he considers more nearly correct than 0.0006. For gas the velocity varies inversely as the square root of the density, and for gas of a density  $G$ , relative to air as 1, Rix gives the formula  $p_1^2 - p_2^2 = 0.0005 \sqrt{G} \times Q^2 L / d^5$ .

If Church's formula is translated into the same form as Johnson's, taking  $f = 0.005, w = 0.07608$  for air at 62° F., and atmospheric pressure, 14.7 lbs. per sq. in., the value of  $K$  is 0.00054. A more convenient

form is  $Q_a = C_1 \sqrt{\frac{(p_1^2 - p_2^2) d^5}{L}}$  in which  $C_1 = \sqrt{1/K}$ . With  $K$  in Johnson's formula taken at 0.0006,  $C_1 = 40.8$ . With  $f$  in Church's formula taken at 0.005,  $C_1 = 43.0$ .

Note that Church's formula gives  $Q$  in cubic feet per second measured at the pressure  $p_1$ , while Johnson's  $Q_a$  is in cubic feet per minute reduced to atmospheric pressure.

Both Church and Johnson assume that the flow varies as  $\sqrt{d^5}$ , the coefficients  $f$  and  $K$  being independent of the diameter. In this respect their formulæ are faulty, for, as Unwin shows, the coefficient of friction is a function of the diameter.

The relation between the results given by these formulæ and those given by the common formula is the relation between  $\sqrt{p_1^2 - p_2^2}$  and  $\sqrt{p_1 - p_2}$ . Taking  $p_1$  (in any unit) as 100, and different drops in pressure, the relative results are as follows:

Pressure drop.....	1	10	20	40	60	80
Values of $p_2$ .....	99	90	80	60	40	20
$\sqrt{p_1^2 - p_2^2} \div \sqrt{p_1 - p_2}$ .....	14.1	13.8	13.4	12.2	11.8	10.8
Ratio, 14.1 = 100.....	100	97.6	95.0	86.5	83.7	76.6

It thus appears that the calculated result by Johnson's formula is not more than 5 per cent less than that calculated by the common formula, when the same value of  $f$  is used, if the drop in pressure is not greater than 20 per cent of  $p_1$ .

**Comparison of Different Formulæ.**—We may compare the several formulæ given above by applying them to the data of the St. Gothard experiments, as in table p. 620.

The value of  $Q$  is given as reduced to atmospheric pressure, 14.7 lb. per sq. in. and 62° F. The length of the pipe 7.87 in. diam. was 15,092 ft., and that of the pipe 5.91 in. diam., 1712.6 ft. The mean temperature of the air in the large pipe was 70° F. and in the small pipe 80° F.



In the table, Formula (1) is the common formula,  $Q_1 = c \sqrt{\frac{(p_1 - p_2) d^5}{w L}}$ .

Formula (2) is Unwin's,  $Q_1 = K \sqrt{\frac{(p_1 - p_2) d^5}{w L (1 + 3.6/d)}}$ .

Formula (3) is Johnson's,  $Q_a = C_1 \sqrt{\frac{(p_1^2 - p_2^2) d^5}{L}}$ .

$Q_1$  = cubic ft. per min. at pressure  $p_1$ .

$Q_a$  = cubic ft. per min. reduced to atmospheric pressure =  $Q p_1 \div 14.7$ .

Di- am- eter, in.	Mean Vel. Ft. Per Sec.	Cu. Ft. Per Min. Q	Lb. Per Sec.	Absolute Pressures. lb. per sq. in.		Coefficient in Formula.			Ratio of Coefficient to Average Value.		
				$p_1$	$p_2$	(1)	(2)	(3)	(1)	(2)	(3)
						c	K	$C_1$			
7.87	19.3	2105	2.669	82.32	77.03	76.0	89.6	51.3	1.06	1.03	1.09
7.87	16.3	1401	1.776	63.95	60.71	73.5	86.5	49.3	1.02	0.99	1.05
7.87	15.6	1169	1.483	56.45	53.66	70.2	82.8	46.0	0.98	0.95	0.98
5.91	37.1	2105	2.669	77.03	73.50	74.8	94.9	44.5	1.04	1.09	0.95
5.91	29.3	1169	1.483	53.66	52.04	65.5	83.1	43.6	0.91	0.95	0.93
Average.....						72.0	87.4	46.9			

The above comparison shows that no one of three formulæ fits the St. Gothard experiments better than any other; each one when applied with the average value of its coefficient may give a result that differs as much as 9 per cent from the observed result.

**Arson's Experiments.**—Unwin quotes some experiments by A. Arson on the flow of air through cast-iron pipes which showed that the coefficient of friction varied with the velocity. For a velocity of 100 ft. per sec., and without much error for higher velocities, Unwin finds that the values of  $f$  agree fairly with the formula  $f = 0.005 (1 + 3.6/d)$ . Translating the figures given by him for the varying values of  $f$  into values of  $c$  for use in the common formula, we have the following:

Diameter of pipe, inches.....	1.97	3.19	4.06	10	12.8	19.7		
Values of $c$ .	} $V = 10$ ft. per sec.	35.7	39.4	39.8	49.2	52.8	64.7	
		50	38.6	42.5	45.0	51.5	55.7	65.2
		100	41.3	45.5	46.0	53.6	56.4	65.4

The values of  $c$  for the same diameter with  $f = 0.0028 (1 + 3.6/d)$ , as deduced by Unwin from Stockalper's experiments are: 51.4, 57.9, 62.3, 73.7, 75.9, 79.1.

Unwin says that Stockalper's pipes were probably less rough than Arson's. The values of  $c$  according to Stockalper's experiments range from 21 to 37 per cent higher than those calculated from the formula derived from Arson's experiments.

**Use of the Formulæ.**—It is evident from the above comparisons that any formula for the flow of air or gas must be considered as only a rough approximation to the actual flow, and that an observed result may differ as much as 40 per cent from that calculated by a formula. Part of this error is due to variations in the roughness of pipes, part due to error in measurements of the actual flow, and part due to the fact that the coefficients of the several formulæ are based on too few experiments. In the light of our present knowledge, Unwin's formula

for moderate drop,  $Q = 87 \sqrt{\frac{(p_1 - p_2) d^5}{w L (1 + 3.6/d)}}$  is probably the best one to use for all cases in which the drop in pressure does not exceed 20 per cent of the absolute initial pressure, and Johnson's formula,

$Q_a = 47 \sqrt{\frac{(p_1^2 - p_2^2) d^5}{L}}$  for cases in which the drop is larger and the pipes

are not less than 12 inches diameter. For smaller pipes the term  $(1 + 3.6/d)$  had better be used after  $L$  in the denominator. These formulæ with the coefficients given apply only to straight pipes with a fairly smooth interior surface. For crooked or rough pipes it may be well to use the common formula with the coefficients derived from Arson's experiments, given above.

Another comparison of the three formulæ may be made by applying them to some extreme cases, as follows: The initial pressure is taken at 100 lb. absolute per sq. in., the corresponding density is 0.5176 lb. per cu. ft.; diameters are assumed at 1 in. and 48 in., the drop in pressure 1 lb. and 40 lb. and the length 100 ft. and 40,000 ft., making eight cases in all. A ninth case is taken with intermediate values: diameter, 10 in.; length, 1,000 ft.; and drop, 1 lb. The results are given in the following table. The results obtained by Johnson's formula have been reduced by dividing them by the ratio  $(100 \div 14.7)$  to obtain  $Q$ . The value of  $c$  in the common formula is taken at 72, the average figure from the St. Gothard experiments.

Diam., In.	1				48				10
	1		40		1		40		1
$p_1 - p_2$ , lb.									
$L$ , ft. . . . .	100	40,000	100	40,000	100	40,000	100	40,000	1,000
Formula	Cubic feet of air per minute at the pressure $p_1$ .								
Common . . . . .	10.08	0.50	63.3	3.16	159,800	7,990	1,010,000	50,500	1,008
Unwin . . . . .	5.64	0.28	35.7	1.78	186,200	9,310	1,178,000	58,900	1,037
Johnson . . . . .	9.75	0.49	55.3	2.76	155,600	7,778	882,300	44,110	974

Ratio of results to Unwin's = 1.

Common . . . . .	1.79	1.79	1.78	1.78	0.86	0.86	0.86	0.86	0.96
Johnson . . . . .	1.73	1.75	1.55	1.55	0.84	0.84	0.75	0.75	0.94

These figures show that while the three formulæ agree fairly well for the 10-in. pipe with 1-lb. drop in 1,000 ft., they show wide disagreements when a great range of diameters, lengths, and drops in pressure are taken. For the 1-in. pipe Unwin's figures are from 35 to 45 per cent lower than those given by the common formula or by Johnson's, but they are not therefore certainly too low. We have a check on them in Culley and Sabine's experiments on  $2\frac{1}{4}$ -in. lead pipes, 2000 to nearly 6000 ft. long, quoted by Unwin, which gave a value of  $f = 0.07$ . Unwin's formula,  $f = 0.0028 (1 + 3.6/d)$  gives  $f = 0.0073$ . The corresponding values of  $c$  in the common formula are 54.7 and 53.2.

**Formula for Flow of Air at Low Pressures.**—For ventilating and similar purposes, air is usually carried at pressures, but slightly above that of the atmosphere. Pressures are measured in inches of water column or in ounces per square inch above atmospheric pressure. For smooth and straight circular pipes, probably the best formula to

use is Unwin's,  $Q = 87 \sqrt{\frac{(p_1 - p_2) d^5}{w L (1 + 3.6/d)}}$ , the coefficient 87 being derived from the St. Gothard experiments on compressed air. In order to put the formula into a more convenient form for low pressures, let  $h$  = head or difference in pressures measured in inches of water column, = 27.712  $(p_1 - p_2)$ , and take  $w = 0.07493$  = density of air, lb. per cu. ft. at 70° and atmospheric pressure, then  $Q =$

$$87 \times \sqrt{\frac{h}{27.71} \frac{1}{.07493} \frac{d^5}{L (1 + 3.6/d)}} = 60.37 \sqrt{\frac{h d^5}{L (1 + 3.6/d)}}, \text{ or } Q =$$

$C \sqrt{\frac{h d^5}{L}}$ , in which  $C$  is a coefficient varying with the diameter, values for different diameters being given in the table below. For other temperatures and pressures, the flow varying inversely as the square root of the density, the figure 0.07493 in the above equation should be replaced by  $0.07493 \times \frac{p}{14.7} \times \frac{530}{460 + T}$ , in which  $p$  = absolute pressure,

lb. per sq. in., and  $T$  = degrees F.  $Q$  is the quantity in cubic feet per minute measured at the given pressure and temperature.

### Flow of Air at Low Pressures.

$Q$  = cubic feet per minute =  $C \sqrt{\frac{h d^5}{L}}$ ,  $h$  = drop in pressure, inches of water column,  $d$  = diameter in inches,  $L$  = length of pipe in feet.  $C$ , a coefficient varying with the diameter. The values of  $C$  in the table are based on air at atmospheric pressure and 70° F., and the values of  $Q$  are calculated for the same pressure and temperature and for a drop of 1-inch water column in 100 ft.

$d$ .	$C$ .	$Q$ .	$d$ .	$C$ .	$Q$ .	$d$ .	$C$ .	$Q$ .	$d$ .	$C$ .	$Q$ .
4	43.9	140	10	51.8	1,637	22	56.0	12,700	42	57.9	66,240
5	46.1	257	12	53.0	2,642	24	56.3	15,880	48	58.2	92,930
6	47.7	421	14	53.9	3,950	26	56.6	19,500	54	58.4	125,200
7	49.1	636	16	54.6	5,585	28	56.8	23,580	60	58.6	163,500
8	50.1	908	18	55.1	7,579	30	57.1	28,130	66	58.8	208,000
9	51.0	1,240	20	55.6	9,946	36	57.6	44,760	72	58.9	259,200

For any other pressure drop than 1-inch water column per 100 ft., multiply  $Q$  by the square root of the drop, or by the factor given below:  
 Drop,  $h$ ... 0.5 2 3 4 6 8 10 12 14 16 18 20  
 Factor... 0.71 1.41 1.73 2 2.45 2.83 3.16 3.46 3.74 4 4.24 4.47

For drop in ounces per square inch (1 oz. = 1.732 in. of water) the factors are:

Drop, oz.. 0.5 1 2 3 4 5 6 7 8 9 10 12  
 Factor... 0.93 1.32 1.86 2.28 2.63 2.94 3.22 3.48 3.72 3.95 4.16 4.56

**Loss of Pressure in Ounces per Square Inch.**—B. F. Sturtevant Co. gives the following formula:

$$p_1 = \frac{L v^2}{25,000 d}; v = \sqrt{\frac{25,000 d p_1}{L}}; d = \frac{0.0000025 L v^2}{p}$$

$p_1$  = loss of pressure, ounces per sq. in.;  $v$  = velocity, ft. per sec.;  $d$  = diameter, inches;  $L$  = length, ft. From the value of  $v$  we obtain the flow in cubic feet per minute.  $Q = 60 a v = 60 \times 0.7854 d^2 \div 144 \times$

$\sqrt{\frac{25,000 d p_1}{L}} = 51.74 \sqrt{\frac{p_1 d^5}{L}}$ . If the drop is taken in inches of water

column,  $h$ , then  $Q = 39.24 \sqrt{\frac{h d^5}{L}}$ . This formula gives a value of  $Q$  9 per cent less than that given in the above table for a 4-inch pipe, and 33 per cent less for a 72-inch pipe.

**Flow in Rectangular Pipes.**—It is common practice to make air pipes for ventilating purposes rectangular instead of circular section in order to economize space. No records of experiments on the flow of air in such pipes are available, but a fair estimate of their capacity as compared with that of circular pipes of the same area may be made on the assumption that they follow the law of Chezy's formula for flow of water, viz.: that the flow is proportional to the square root of the mean hydraulic radius  $r$ , which is defined as the quotient of the area divided by the perimeter of the wetted surface. For a circular pipe  $r = 1/4$  diameter in feet, and for a square pipe of the same area,  $r = 0.222d$ . For rectangles of the same area  $r$  will decrease as the ratio of the longer to the shorter side increases. For different proportions of sides, the values of  $r$  and the ratio of  $\sqrt{r}$  to the value of  $\sqrt{r_1}$ , the hydraulic radius of a circular pipe having the same area, are as below:

Ratio of sides... (circle) 1(sq.) 1.5 2 3 4 5 6  
 $r = \dots \dots \dots$  0.25 0.222 0.217 0.209 0.192 0.177 0.165 0.155  
 Ratio  $\sqrt{r} \div \sqrt{r_1}$  1 0.942 0.932 0.914 0.875 0.842 0.813 0.787

That is, a square pipe will have 94 per cent of the carrying capacity of a circular pipe of the same area, and a rectangular pipe whose sides are in the ratio of 6 to 1 will have only 79 per cent of the capacity of a circular pipe of the same area.



**Flow of Compressed Air in Pipes of Standard Lap-welded Sizes.**

For a drop in pressure of 1 lb. per 1000 ft. length. Cubic feet per minute.

Nominal Size, In.	Gage Pressure.				Actual Internal Diam., In.	Nominal Size, In.	Gage Pressure.				
	Gage Pressure.						Actual Internal Diam., In.	Gage Pressure.			
	60	70	80	90				100	60	70	80
1/2	0.5183	0.4868	0.4603	0.4378	0.4183	8	660.8	620.6	586.9	558.1	533.3
3/4	1.176	1.104	1.044	0.9929	0.9487	9	892.3	838.1	792.5	753.7	720.1
1	2.367	2.223	2.103	2.000	1.910	10	1204	1131	1070	1017	971.9
1 1/4	5.211	4.894	4.628	4.402	4.205	11	1541	1447	1369	1302	1244
1 1/2	8.096	7.604	7.191	6.838	6.534	12	1936	1818	1719	1635	1299
2	16.40	15.40	14.57	13.85	12.94	13	2506	2353	2226	2117	2022
2 1/2	24.10	22.63	21.40	20.35	19.45	14	3029	2845	2690	2559	2445
3	3.068	49.47	43.94	41.79	39.92	15	3612	3392	3208	3051	2915
3 1/2	73.92	69.43	65.66	62.44	59.66	17 O.D.	4237	3979	3763	3579	3419
4	4.026	104.5	92.85	88.30	84.36	18 O.D.	4923	4624	4372	4158	3973
4 1/2	142.0	133.4	126.2	120.0	114.6	20 O.D.	6540	6143	5809	5524	5278
5	5.047	193.5	171.9	163.5	156.2	22 O.D.	8512	7994	7560	7189	6869
6	6.065	316.5	281.1	267.3	255.4	24 O.D.	10824	10072	9643	9170	8762
7	470.0	441.4	417.4	397.0	379.3						

Formula  $Q = c \sqrt{\frac{p_1 - p_2}{wL}}$ .  $Q$  = cu. ft. per min. measured at pressure  $p_1$  and 62° F.

$p_1 - p_2$  = lbs. per sq. in.;  $w$  = density, lb. per cu. ft.;  $d$  = diam., inches;  $L$  = length, feet.

Values of  $c = 87 \sqrt{\frac{1}{1 + 3.6/d}}$

Diameter, inches.....	1/2	3/4	1	1 1/4	1 1/2	2	2 1/2	3	3 1/2	4	4 1/2	5	6	7
$c$ = .....	33.4	37.5	41.3	45.8	48.4	52.5	55.5	59.0	61.3	63.2	64.8	66.5	68.7	70.7
Diameter, inches...	8	9	10	11	12	13	14	15	17 O.D.	18 O.D.	20 O.D.	22 O.D.	24 O.D.	28 O.D.
$c$ = .....	72.2	73.4	74.5	75.5	76.3	77.1	77.7	78.2	78.7	79.1	79.8	80.4	80.9	80.9

For any other drop than 1 lb. per sq. in. in 1,000 ft. length, multiply the figures in the table by the square root of the drop.

**Volume of Air Transmitted in Cubic Feet per Minute in Pipes of Various Diameters.**

$$\text{Formula } Q = \frac{0.7854}{144} d^2v \times 60.$$

Veloc'y of Flow, Ft. per Sec.	Actual Diameter of Pipe in Inches.											
	1	2	3	4	5	6	8	10	12	16	20	24
1	0.327	1.31	2.95	5.24	8.18	11.78	20.94	32.73	47.12	83.77	130.9	188.5
2	0.655	2.62	5.89	10.47	16.36	23.56	41.89	65.45	94.25	167.5	261.8	377.0
3	0.982	3.93	8.84	15.7	24.5	35.3	62.8	98.2	141.4	251.3	392.7	565.5
4	1.31	5.24	11.78	20.9	32.7	47.1	83.8	131	188	335	523	754
5	1.64	6.54	14.7	26.2	41.0	59.0	104	163	235	419	654	942
6	1.96	7.85	17.7	31.4	49.1	70.7	125	196	283	502	785	1131
7	2.29	9.16	20.6	36.6	57.2	82.4	146	229	330	586	916	1319
8	2.62	10.5	23.5	41.9	65.4	94	167	262	377	670	1047	1508
9	2.95	11.78	26.5	47	73	106	188	294	424	754	1178	1696
10	3.27	13.1	29.4	52	82	118	209	327	471	838	1307	1885
12	3.93	15.7	35.3	63	98	141	251	393	565	1005	1571	2262
15	4.91	19.6	44.2	78	122	177	314	491	707	1256	1963	2827
18	5.89	23.5	53	94	147	212	377	589	848	1508	2356	3393
20	6.54	26.2	59	105	164	235	419	654	942	1675	2618	3770
24	7.85	31.4	71	125	196	283	502	785	1131	2010	3141	4524
25	8.18	32.7	73	131	204	294	523	818	1178	2094	3272	4712
28	9.16	36.6	82	146	229	330	586	916	1319	2346	3665	5278
30	9.8	39.3	88	157	245	353	628	982	1414	2513	3927	5655

**Effect of Bends in Pipes. (Norwalk Iron Works Co.)**

Radius of elbow, in diameter of pipe =	5	3	2	1 1/2	1 1/4	1	3/4	1/2
Equivalent lengths of straight pipe, diams.	7.85	8.24	9.03	10.36	12.72	17.51	35.09	121.2

E. A. Rix and A. E. Chodzko, in their treatise on Compressed Air (1896), give the following as the loss in pressure through 90° bends.  
 Rad. of bend ÷ internal diam. of pipe..... 1                    2                    3                    4                    5  
 Loss in lb. per sq. in. .... 0.005v<sup>2</sup>    .0022v<sup>2</sup>    .0016v<sup>2</sup>    .0013v<sup>2</sup>    .0012v<sup>2</sup>  
 v is the velocity of air at entrance, in feet per second.

**Friction of Air in Passing through Valves and Elbows.** W. L. Saunders, *Compressed Air*, Dec., 1902. — The following figures give the length in feet of straight pipe which will cause a reduction in pressure equal to that caused by globe valves, elbows, and tees in different diameters of pipe.

Diam. of pipe, in..	1	1 1/2	2	2 1/2	3	3 1/2	4	5	6	7	8	10
Globe Valves.....	2	4	7	10	13	16	20	28	36	44	53	70
Elbows and Tees .	2	3	5	7	9	11	13	19	24	30	35	47

**Measurement of the Velocity of Air in Pipes by an Anemometer.**  
 — Tests were made by B. Donkin, Jr. (*Inst. Civil Engrs.*, 1892), to compare the velocity of air in pipes from 8 in. to 24 in. diam., as shown by an anemometer 2 3/4 in. diam. with the true velocity as measured by the time of descent of a gas-holder holding 1622 cubic feet. A table of the results with discussion is given in *Eng'g News*, Dec. 22, 1892. In pipes from 8 in. to 20 in. diam. with air velocities of from 140 to 690 feet per minute the anemometer showed errors varying from 14.5% fast to 10% slow. With a 24-inch pipe and a velocity of 73 ft. per minute, the anemometer gave from 44 to 63 feet, or from 13.6 to 39.6% slow. The practical conclusion drawn from these experiments is that anemometers for the measurement of velocities of air in pipes of these diameters should be used with great caution. The percentage of error is not constant, and varies considerably with the diameter of the pipes and the speeds of air. The use of a baffle consisting of a perforated plate, which tended to equalize the velocity in the center and at the sides in some cases diminished the error.

The impossibility of measuring the true quantity of air by an anemometer held stationary in one position is shown by the following figures, given by Wm. Daniel (*Proc. Inst. M. E., 1875*), of the velocities of air found at different points in the cross-sections of two different airways in a mine.

DIFFERENCES OF ANEMOMETER READINGS IN AIRWAYS.  
8 ft. square.

1712	1795	1859	1329
1622	1685	1782	1091
1477	1344	1524	1049
1262	1356	1293	1333

Average 1469.

5 × 8 ft.

1170	1209	1288
948	1104	1177
1134	1049	1106

Average 1132.

**Equalization of Pipes.**—It is frequently desired to know what number of pipes of a given size are equal in carrying capacity to one pipe of a larger size. At the same velocity of flow the volume delivered by two pipes of different sizes is proportional to the squares of their diameters; thus, one 4-inch pipe will deliver the same volume as four 2-inch pipes. With the same head, however, the velocity is less in the smaller pipe, and the volume delivered varies about as the square root of the fifth power (i.e., as the 2.5 power). The following table has been calculated on this basis. The figures opposite the intersection of any two sizes is the number of the smaller-sized pipes required to equal one of the larger. Thus one 4-inch pipe is equal to 5.7 two-inch pipes.

Diam. In.	1	2	3	4	5	6	7	8	9	10	12	14	16	18	20	24
2	5.7	1														
3	15.6	2.8	1													
4	32.0	5.7	2.1	1												
5	55.9	9.9	3.6	1.7	1											
6	88.2	15.6	5.7	2.8	1.6	1										
7	130	22.9	8.3	4.1	2.3	1.5	1									
8	181	32.0	11.7	5.7	3.2	2.1	1.4	1								
9	243	43.0	15.6	7.6	4.3	2.8	1.9	1.3	1							
10	316	55.9	20.3	9.9	5.7	3.6	2.4	1.7	1.3	1						
11	401	70.9	25.7	12.5	7.2	4.6	3.1	2.2	1.7	1.3						
12	499	88.2	32.0	15.6	8.9	5.7	3.8	2.8	2.1	1.6	1					
13	609	108	39.1	19.0	10.9	7.1	4.7	3.4	2.5	1.9	1.2					
14	733	130	47.0	22.9	13.1	8.3	5.7	4.1	3.0	2.3	1.5	1				
15	871	154	55.9	27.2	15.6	9.9	6.7	4.8	3.6	2.8	1.7	1.2				
16	...	181	65.7	32.0	18.3	11.7	7.9	5.7	4.2	3.2	2.1	1.4	1			
17	...	211	76.4	37.2	21.3	13.5	9.2	6.6	4.9	3.8	2.4	1.6	1.2			
18	...	243	88.2	43.0	24.6	15.6	10.6	7.6	5.7	4.3	2.8	1.9	1.3	1		
19	...	278	101	49.1	28.1	17.8	12.1	8.7	6.5	5.0	3.2	2.1	1.5	1.1		
20	...	316	115	55.9	32.0	20.3	13.8	9.9	7.4	5.7	3.6	2.4	1.7	1.3	1	
22	...	401	146	70.9	40.6	25.7	17.5	12.5	9.3	7.2	4.6	3.1	2.2	1.7	1.3	
24	...	499	181	88.2	50.5	32.0	21.8	15.6	11.6	8.9	5.7	3.8	2.8	2.1	1.6	1
25	...	609	221	108	61.7	39.1	26.6	19.0	14.2	10.9	7.1	4.7	3.4	2.5	1.9	1.2
28	...	733	266	130	74.2	47.0	32.0	22.9	17.1	13.1	8.3	5.7	4.1	3.0	2.3	1.5
30	...	871	316	154	88.2	55.9	38.0	27.2	20.3	15.6	9.9	6.7	4.8	3.6	2.8	1.7
36	...	...	499	243	130	88.2	60.0	43.0	32.0	24.6	15.6	10.6	7.6	5.7	4.3	2.8
42	...	...	733	357	205	130	88.2	63.2	47.0	36.2	19.0	15.6	11.2	8.3	6.4	4.1
48	...	...	...	499	286	181	123	88.2	62.7	50.5	32.0	21.8	15.6	11.6	8.9	5.7
54	...	...	...	...	670	383	243	165	118	88.2	67.8	43.0	29.2	20.9	15.6	12.0
60	...	...	...	...	871	499	316	215	154	115	88.2	55.9	38.0	27.2	20.3	15.6



## WIND.

**Force of the Wind.** — Smeaton in 1759 published a table of the velocity and pressure of wind, as follows:

VELOCITY AND FORCE OF WIND, IN POUNDS PER SQUARE INCH.

Miles per Hour.	Feet per Second.	Force per Sq. Ft., Pounds.	Common Appellation of the Force of Wind.	Miles per Hour.	Feet per Second.	Force per Sq. Ft., Pounds.	Common Appellation of the Force of Wind.
1	1.47	0.005	Hardly perceptible.	18	26.4	1.55	} Very brisk.
2	2.93	0.020		} Just perceptible.	20	29.34	
3	4.4	0.044	25		36.67	3.075	
4	5.87	0.079	} Gentle, pleasant wind.	30	44.00	4.429	} High wind.
5	7.33	0.123		35	51.34	6.027	
6	8.8	0.177		40	58.68	7.873	} Very high storm.
7	10.25	0.241	} Pleasant, brisk gale	45	66.01	9.963	
8	11.75	0.315		50	73.35	12.30	
9	13.2	0.400	} Great storm.	55	80.7	14.9	
10	14.67	0.492		60	88.00	17.71	
12	17.6	0.708	} Hurricane.	65	95.3	20.85	
14	20.5	0.964		70	102.5	24.1	
15	22.00	1.107	} Immense hurricane.	75	110.00	27.7	
16	23.45	1.25		80	117.36	31.49	
				100	146.67	49.2	

The pressures per square foot in the above table correspond to the formula  $P = 0.005 V^2$ , in which  $V$  is the velocity in miles per hour. *Eng'g News*, Feb. 9, 1893, says that the formula was never well established, and has floated chiefly on Smeaton's name and for lack of a better. It was put forward only for surfaces for use in windmill practice. The trend of modern evidence is that it is approximately correct only for such surfaces, and that for large, solid bodies it often gives greatly too large results. Observations by others are thus compared with Smeaton's formula:

Old Smeaton formula . . . . .	$P = 0.005 V^2$
As determined by Prof. Martin . . . . .	$P = 0.004 V^2$
“ “ Whipple and Dines . . . . .	$P = 0.0029 V^2$

At 60 miles per hour these formulas give for the pressure per square foot, 18, 14.4, and 10.44 lbs., respectively, the pressure varying by all of them as the square of the velocity. Lieut. Crosby's experiments (*Eng'g*, June 13, 1890), claiming to prove that  $P = fV$  instead of  $P = fV^2$ , are discredited.

Experiments by M. Eiffel on plates let fall from the Eiffel tower in Paris gave coefficients of  $V^2$  ranging from 0.0027 for small plates to 0.0032 for plates 10 sq. ft. area. For plates larger than 10 sq. ft. the coefficient remained constant at 0.0032. — *Eng'g*, May 8, 1908.

A. R. Wolff ("The Windmill as a Prime Mover," p. 9) gives as the theoretical pressure per sq. ft. of surface,  $P = dQv/g$ , in which  $d$  = density of air in pounds per cu. ft. =  $\frac{0.018743(p+P)}{t}$ ;  $p$  being the barometric pres-

sure per square foot at any level, and temperature of 32° F.,  $t$  any absolute temperature,  $Q$  = volume of air carried along per square foot in one second,  $v$  = velocity of the wind in feet per second,  $g = 32.16$ . Since  $Q = v$  cu. ft. per sec.,  $P = dv^2/g$ . Multiplying this by a coefficient 0.93 found by experiment, and substituting the above value of  $d$ , he obtains

$$P = \frac{0.017431 \times p}{\frac{t \times 32.16}{v^2} - 0.018743}, \text{ and when } p = 2116.5 \text{ lb. per sq. ft., or average}$$

atmospheric pressure at the sea-level,  $P = \frac{36.8929}{\frac{t \times 32.16}{v^2} - 0.018743}$ , an ex-

pression in which the pressure is shown to vary with the temperature; and he gives a table showing the relation between velocity and pressure

for temperatures from  $0^{\circ}$  to  $100^{\circ}$  F., and velocities from 1 to 80 miles per hour. For a temperature of  $45^{\circ}$  F. the pressures agree with those in Smeaton's table, for  $0^{\circ}$  F. they are about 10 per cent greater, and for  $100^{\circ}$ , 10 per cent less.

Prof. H. Allen Hazen, *Eng'g News*, July 5, 1890, says that experiments with whirling arms, by exposing plates to direct wind, and on locomotives with velocities running up to 40 miles per hour, have invariably shown the resistance to vary with  $V^2$ . The coefficient of  $V^2$  has been found in some experiments with very short whirling arms and low velocities to vary with the perimeter of the plate, but this entirely disappears with longer arms or straight line motion, and the only question now to be determined is the value of the coefficient. Perhaps some of the best experiments for determining this value were tried in France in 1886 by carrying flat boards on trains. The resulting formula in this case was, for 44.5 miles per hour,  $p = 0.00535 SV^2$ .

Prof. Kernot, of Melbourne (*Eng. Rec.*, Feb. 20, 1894), states that experiments at the Forth Bridge showed that the average pressure on surfaces as large as railway carriages, houses, or bridges never exceeded two-thirds of that upon small surfaces of one or two square feet, and also that an inertia effect, which is frequently overlooked, may cause some forms of anemometer to give false results enormously exceeding the correct indication. Experiments made by Prof. Kernot at speeds varying from 2 to 15 miles per hour agreed with the earlier authorities. The pressure upon one side of a cube, or of a block proportioned like an ordinary carriage, was found to be 0.9 of that upon a thin plate of the same area. The same result was obtained for a square tower. A square pyramid, whose height was three times its base, experienced 0.8 of the pressure upon a thin plate equal to one of its sides, but if an angle was turned to the wind the pressure was increased by fully 20%. A bridge consisting of two plate-girders connected by a deck at the top was found to experience 0.9 of the pressure on a thin plate equal in size to one girder, when the distance between the girders was equal to their depth, and this was increased by one-fifth when the distance between the girders was double the depth. A lattice-work in which the area of the openings was 55% of the whole area experienced a pressure of 80% of that upon a plate of the same area. The pressure upon cylinders and cones was proved to be equal to half that upon the diametral planes, and that upon an octagonal prism to be 20% greater than upon the circumscribing cylinder. A sphere was subject to a pressure of 0.36 of that upon a thin circular plate of equal diameter. A hemispherical cup gave the same result as the sphere; when its concavity was turned to the wind the pressure was 1.15 of that on a flat plate of equal diameter. When a plane surface parallel to the direction of the wind was brought nearly into contact with a cylinder or sphere, the pressure on the latter bodies was augmented by about 20%, owing to the lateral escape of the air being checked. Thus it is possible for the security of a tower or chimney to be impaired by the erection of a building nearly touching it on one side.

**Pressures of Wind Registered in Storms.** — Mr. Frizell has examined the published records of Greenwich Observatory from 1849 to 1869, and reports that the highest pressure of wind he finds recorded is 41 lb. per sq. ft., and there are numerous instances in which it was between 30 and 40 lb. per sq. ft. Prof. Henry says that on Mount Washington, N. H., a velocity of 150 miles per hour has been observed, and at New York City 60 miles an hour, and that the highest winds observed in 1870 were of 72 and 63 miles per hour, respectively. Lieut. Dunwoody, U. S. A., says, in substance, that the New England coast is exposed to storms which produce a pressure of 50 lb. per sq. ft. — *Eng. News*, Aug. 20, 1880.

## WINDMILLS.

**Power and Efficiency of Windmills.** — Rankine, S. E., p. 215, gives the following: Let  $Q$  = volume of air which acts on the sail, or part of a sail, in cubic feet per second,  $v$  = velocity of the wind in feet per second,  $s$  = sectional area of the cylinder, or annular cylinder of wind, through which the sail, or part of the sail, sweeps in one revolution,  $c$  = a coefficient to be found by experience; then  $Q = cvs$ . Rankine, from experimental data given by Smeaton, and taking  $c$  to include an allowance for

friction, gives for a wheel with four sails, proportioned in the best manner,  $c = 0.75$ . Let  $A$  = weather angle of the sail at any distance from the axis, i.e., the angle the portion of the sail considered makes with its plane of revolution. This angle gradually diminishes from the inner end of the sail to the tip;  $u$  = the velocity of the same portion of the sail, and  $E$  = the efficiency. The efficiency is the ratio of the useful work performed to the whole energy of the stream of wind acting on the surface  $s$  of the wheel, which energy is  $Dsv^3 \div 2g$ ,  $D$  being the weight of a cubic foot of air. Rankine's formula for efficiency is

$$E = \frac{Ru}{Dsv^3/2g} = c \left\{ \frac{u}{v} \sin 2A - \frac{u^2}{v^2} (1 - \cos 2A + f) - f \right\},$$

in which  $c = 0.75$  and  $f$  is a coefficient of friction found from Smeaton's data = 0.016. Rankine gives the following from Smeaton's data:

$A$ = weather-angle . . . . .	= 7°	13°	19°
$V + v$ = ratio of speed of greatest efficiency, for a given weather-angle, to that of the wind . . . . .	= 2.63	1.86	1.41
$E$ = efficiency . . . . .	= 0.24	0.29	0.31

Rankine gives the following as the best values for the angle of weather at different distances from the axis:

Distance in sixths of total radius	1	2	3	4	5	6
Weather angle . . . . .	18°	19°	18°	16°	12 1/2°	7°

But Wolff (p. 125) shows that Smeaton did not term these the best angles but simply says they "answer as well as any," possibly any that were in existence in his time. Wolff says that they "cannot in the nature of things be the most desirable angles." Mathematical considerations, he says, conclusively show that the angle of impulse depends on the relative velocity of each point of the sail and the wind, the angle growing larger as the ratio becomes greater. Smeaton's angles do not fulfil this condition. Wolff develops a theoretical formula for the best angle of weather, and from it calculates a table of the best angles for different relative velocities of the blades and the wind, which differ widely from those given by Rankine.

A. R. Wolff, in an article in the *American Engineer*, gives the following (see also his treatise on Windmills):

Let  $c$  = velocity of wind in feet per second;

$n$  = number of revolutions of the windmill per minute;

$b_0, b_1, b_2, b_x$  be the breadth of the sail or blade at distances  $l_0, l_1, l_2, l_3$ , and  $l$ , respectively, from the axis of the shaft;

$l_0$  = distance from axis of shaft to beginning of sail or blade proper.

$l$  = distance from axis of shaft to extremity of sail proper;

$v_0, v_1, v_2, v_3, v_x$  = the velocity of the sail in feet per second at distances  $l_0, l_1, l_2, l_3, l$ , respectively, from the axis of the shaft;

$a_0, a_1, a_2, a_3, a_x$  = the angles of impulse for maximum effect at distances  $l_0, l_1, l_2, l_3, l$ , respectively, from the axis of the shaft;

$a$  = the angle of impulse when the sails or blocks are plane surfaces so that there is but one angle to be considered;

$N$  = number of sails or blades of windmill;

$K = 0.93$ ;

$d$  = density of wind (weight of a cubic foot of air at average temperature and barometric pressure where mill is erected);

$W$  = weight of wind-wheel in pounds;

$f$  = coefficient of friction of shaft and bearings;

$D$  = diameter of bearing of windmill in feet.

The effective horse-power of a windmill with plane sails will equal

$$\frac{(l - l_0) Kc^2 d N}{550 g} \times \text{mean of } \left\{ v_0 \left( \sin a - \frac{v_0}{c} \cos a \right) b_0 \cos a \right. \\ \left. v_x \left( \sin a - \frac{v_x}{c} \cos a \right) b_x \cos a \right\} - \frac{fW \times 0.05236 n D}{550}.$$



The effective horse-power of a windmill of shape of sail for maximum effect equals

$$\frac{N(l-l_0)Kdc^3}{2200g} \times \text{mean of} \left( \frac{2\sin^2 a_0 - 1}{\sin^2 a_0} b_0, \frac{2\sin^2 a_1 - 1}{\sin^2 a_1} b_1 \dots \dots \frac{2\sin^2 a_x - 1}{\sin^2 a_x} b_x \right) - \frac{fW \times 0.05236 nD}{550}$$

The mean value of quantities in brackets is to be found according to Simpson's rule. Dividing *l* into 7 parts, finding the angles and breadths corresponding to these divisions by substituting them in quantities within brackets will be found satisfactory. Comparison of these formulæ with the only fairly reliable experiments in windmills (Coulomb's) showed a close agreement of results.

Approximate formulæ of simpler form for windmills of present construction can be based upon the above, substituting actual average values for *a*, *c*, *d*, and *e*, but since improvement in the present angles is possible, it is better to give the formulæ in their general and accurate form.

Wolf gives the following table, based on the practice of an American manufacturer. Since its preparation, he says, over 1500 windmills have been sold on its guaranty (1885), and in all cases the results obtained did not vary sufficiently from those presented to cause any complaint. The actual results obtained are in close agreement with those obtained by theoretical analysis of the impulse of wind upon windmill blades.

**Capacity of the Windmill.**

Designation of Mill.	Velocity of Wind, in Miles per Hour.	Revolutions of Wheel per Minute.	Gallons of Water raised per Minute to an Elevation of						Equivalent Actual Useful Horse-power developed.	Average No. of Hours per Day during which this Result will be obtained.
			25 feet.	50 feet.	75 feet.	100 feet.	150 feet.	200 feet.		
wheel 81/2 ft.	16	70 to 75	6.162	3.016	.....	.....	.....	.....	0.04	8
10 "	16	60 to 65	19.179	9.563	6.638	4.750	.....	.....	0.12	8
12 "	16	55 to 60	33.941	17.952	11.851	8.485	5.680	.....	0.21	8
14 "	16	50 to 55	45.139	22.569	15.304	11.246	7.807	4.998	0.28	8
16 "	16	45 to 50	64.600	31.654	19.542	16.150	9.771	8.075	0.41	8
18 "	16	40 to 45	97.682	52.165	32.513	24.421	17.485	12.211	0.61	8
20 "	16	35 to 40	124.950	63.750	40.800	31.248	19.284	15.938	0.78	8
25 "	16	30 to 35	212.381	106.964	71.604	49.725	37.349	26.741	1.34	8

These windmills are made in regular sizes, as high as sixty feet diameter of wheel; but the experience with the larger class of mills is too limited to enable the presentation of precise data as to their performance.

If the wind can be relied upon in exceptional localities to average a higher velocity for eight hours a day than that stated in the above table, the performance or horse-power of the mill will be increased, and can be obtained by multiplying the figures in the table by the ratio of the cube of the higher average velocity of wind to the cube of the velocity above recorded.

He also gives the following table showing the economy of the windmill. All the items of expense, including both interest and repairs, are reduced to the hour by dividing the costs per annum by 365 × 8 = 2920; the interest, etc., for the twenty-four hours being charged to the eight hours of actual work. By multiplying the figures in the 5th column by 584, the first cost of the windmill, in dollars, is obtained.

## Economy of the Windmill.

Designation of Mill.	Gallons of Water raised 25 ft. per Hour.	Equivalent Actual Useful Horse-power developed.	Average Number of Hours per Day during which this Quantity will be raised.	Expense of Actual Useful Power Developed. in Cents, per Hour.					Expense per Horse-power, in Cents, per Hour.
				For Interest on First Cost (First Cost, including Cost of Windmill, Pump, and Tower, 5% per Annum)	For Repairs and Depreciation (5% of First Cost per Annum).	For Attendance.	For Oil.	Total.	
wheel 8 1/2 ft.	370	0.04	8	0.25	0.25	0.06	0.04	0.60	15.0
10 "	1151	0.12	8	0.30	0.30	0.06	0.04	0.70	5.8
12 "	2036	0.21	8	0.36	0.36	0.06	0.04	0.82	5.9
14 "	2708	0.28	8	0.75	0.75	0.06	0.07	1.63	5.8
16 "	3876	0.41	8	1.15	1.15	0.06	0.07	2.43	5.9
18 "	5861	0.61	8	1.35	1.35	0.06	0.07	2.83	4.6
20 "	7497	0.79	8	1.70	1.70	0.06	0.10	3.56	4.5
25 "	12743	1.34	8	2.05	2.05	0.06	0.10	4.26	3.2

Prof. De Volson Wood (*Am. Mach.*, Oct. 29, 1896) quotes some results by Thos. O. Perry on three wheels, each 5 ft. diam.: *A*, a good "stock" wheel, *B* and *C*, improved wheels. Each wheel was tested with a dynamometer placed 1 ft. from the axis of the wheel, and it registered a constant load at that point of 1.9 lbs. The velocity of the wind in each test was 8.45 miles per hour = 12.4 ft. per second. The number of turns per minute was: *A*, 30.67; *B*, 38.13; *C*, 56.50. The efficiency was: *A*, 0.142; *B*, 0.176; *C*, 0.261. The work of wheel *C* was 674.5 ft. lb. per min. = 0.020 H.P. Assuming that the power increases as the square of the diameter and as the cube of the velocity, a wheel of the quality of *C*, 12 1/2 ft. diam., with a wind velocity of 17 miles per hour, would be required for 1 H.P.; but wheel *C* had an exceptionally high efficiency, and such a high delivery would not likely be obtained in practice.

Prof. O. P. Hood (*Am. Mach.*, April 22, 1897) quotes the following results of experiments by E. C. Murphy; the mills were tested by pumping water:

Wind, miles per hour	8	12.	16.	20.	25.	30
Strokes per min., Mill No. 1, 8-ft. wheel	..	10.2	19.3	25.3	28.1	25
Strokes per min., Mill No. 2, 8-ft. wheel	8	20.2	26.1	28.	27.5	..
Strokes per min., Mill No. 3, 12-ft. wheel	..	4.8	12.7	18.8	23.3	25
Strokes per min., Mill No. 4, 12-ft. wheel	..	6.2	11.9	14.7	16.	..

Mill No. 3 was loaded nearly 90% heavier than mill No. 4.

In a 25-mile wind, seven 12-ft. mills developed, respectively, 0.379, 0.291, 0.309, 0.6, 0.247, 0.219, and 0.184 H.P.; and five 8-ft. mills, 0.043, 0.099, 0.059, 0.099, and 0.005 H.P. These effects include the effects of pumps of unknown and variable efficiency. The variations are largely due to the variable relation of the fixed load on the mill to the most favorable load which that mill might carry at each wind velocity. With each mill the efficiency is a maximum only for a certain load and a certain velocity, and for different loads and velocities the efficiency varies greatly. The useful work of mill No. 3 was equal to 0.6 H.P. in a 25-mile wind, and its efficiency was 5.8%. In a 16-mile wind the efficiency rose to 12.1%, and in a 12-mile wind it fell to 10.9%. The rule of the power developed, varying as the cube of the velocity, is far from true for a single wheel fitted with a single non-adjustable pump, and can only be true when the work of the pump per stroke is adjusted by varying the stroke of the pump, or by other means, for each change of velocity.

R. M. Dyer (*The Iowa Engineer*, July, 1906; also *Mach'y*, Aug., 1907) gives a brief review of the history of windmills, and quotes experiments by T. O. Perry, E. C. Murphy, Prof. F. H. King, and the Aermotor Co. Mr. Perry's experiments are reported in pamphlet No. 20 of the Water

Supply and Irrigation Papers of the U. S. Geological Survey, Mr. Murphy's in pamphlets Nos. 41 and 42 of the same Papers, and Prof. King's, in Bulletin No. 82 of the Agricultural Experiment Station of the University of Wisconsin. The Aermotor Co.'s experiments are described in catalogues of that company. Some of Mr. Dyer's conclusions are as follows:

Experiments showed that  $\frac{7}{8}$  of the zone of interruption could be covered with sails; that the gain in power in from  $\frac{3}{4}$  to  $\frac{7}{8}$  of the surface was so small that the use of the additional material was not justifiable; that the sail surface should extend only two-thirds the distance from the outer diameter to the center; that a wheel running behind the carrying mast is not nearly as efficient as one running in front of the mast; that there should be the least possible obstruction behind the wheel; that to be efficient the velocity of the travel of the vertical circumference of the wheel should be from 1 to  $1\frac{1}{4}$  times the velocity of the wind, hence the necessity of back gearing to reduce the pump speed to 40 strokes per minute as a maximum, which is the limit of safety at which ordinary pumps can be operated.

I hold that no manufacturer will be able to produce a marketable motor which will absorb and deliver, when acted upon by an elastic fluid, like air, in which it is entirely surrounded and submerged, more than 35% of the kinetic energy of the impinging current.

Theoretical demonstrations show that the kinetic energy of the air, impinging on the intercepted area of a wheel, varies as the cube of the wind velocity; consequently, the power of windmills of the same type varies theoretically as the square of the diameter, and as the cube of the wind velocity; but as a wheel is designed to give its best efficiency in low winds, say 10 to 15 miles per hour, we cannot expect that the same angle of sail would obtain the same percentage of efficiency in winds of considerably higher velocity.

The ordinary wheel works most efficiently under wind velocities of from 10 to 12 miles per hour; such wheels will give reasonable efficiency in from 5- to 6-mile winds, while, if the wind blows more than 12 miles per hour, there will be power to spare. Our wheel must work in light winds, such being nearly always present, while the higher velocities only occur at intervals. Mills built for grinding purposes, or geared mills, will develop power almost approaching to the cube of the wind velocity, within reasonable limits, as their speed need not be kept down to a certain number of revolutions per minute, as in the case of the pumping mill.

Should this theoretic condition hold, the following table, showing the amount of power for different sizes of mills at different wind velocities, would apply: Figures show Horse Power.

Size	5 mile.	10 mile.	15 mile.	20 mile.	25 mile.	30 mile.	35 mile.	40 mile.
8 ft. ....	0.011	0.088	0.297	0.704	1.375	2.176	....	....
12 ft. ....	0.025	0.20	0.675	1.6	3.125	5.4	8.57	12.8
16 ft. ....	0.045	0.36	1.215	2.88	5.52	9.75	15.3	21.04

These figures have been proven by laboratory tests at velocities ranging from 10 to 25 miles per hour and more practically by the Murphy tests on mills actually in use, which show very close relation at the wind velocities at which the mills are best adapted.

The Murphy figures are as follows:

Size of mill.	10 mile.	15 mile.	20 mile.
12 ft.	0.21 H.P.	0.58 H.P.	1.05 H.P.
16 ft.	0.29	0.82	1.55

For higher wind velocities the Murphy values fall much under the theoretical values, but the range of velocities over which his experiments extend does not justify any change in the general law except inasmuch as common sense teaches us that theoretic conditions can rarely be attained in actual practice.

In view of the fact that a windmill does not work as efficiently in high winds as in winds under 20 miles per hour my experience would lead me to believe that the following figures (H.P.) would be the probable extension of the Murphy tests:

Size of mill.	25 mile.	30 mile.	35 mile.	40 mile.
12 ft.	2.5	4	5	6
16 ft.	4.	6	8	10

A 20-ft. mill would deliver approximately 50% greater than a 16-ft



The foregoing table must be translated with reasonable allowances for conditions under which wind wheels must work and which cannot well be avoided, *e.g.*: Pumping mills must be made to regulate off at a certain maximum speed to prevent damage to the attached pumping devices. The regulating point is usually between 20- and 25-mile wind velocities, so that no matter how much higher the wind velocity may be the power absorbed and delivered by the wheel will be no greater than that indicated at the regulating point.

Electric storage and lighting from the power of a windmill has been tested on a large scale for several years by Charles F. Brush, at Cleveland, Ohio. In 1887 he erected on the grounds of his dwelling a windmill 56 ft. in diameter, that operates with ordinary wind a dynamo at 500 revolutions per minute, with an output of 12,000 watts — 16 electric horse-power — charging a storage system that gives a constant lighting capacity of 100 16 to 20 candle-power lamps. The current from the dynamo is automatically regulated to commence charging at 330 revolutions and 70 volts, and cutting the circuit at 75 volts. Thus, by its 24 hours' work, the storage system of 408 cells in 12 parallel series, each cell having a capacity of 100 ampere-hours, is kept in constant readiness for all the requirements of the establishment, it being fitted up with 350 incandescent lamps, about 100 being in use each evening. The plant runs at a mere nominal expense for oil, repairs, and attention. (For a fuller description of this plant, and of a more recent one at Marblehead Neck, Mass., see Lieut. Lewis's paper in *Engineering Magazine*, Dec., 1894, p. 475.)

### COMPRESSED AIR.

**Heating of Air by Compression.** — Kimball, in his treatise on Physical Properties of Gases, says: When air is compressed, all the work which is done in the compression is converted into heat, and shows itself in the rise in temperature of the compressed gas. In practice many devices are employed to carry off the heat as fast as it is developed, and keep the temperature down. But it is not possible in any way to totally remove this difficulty. But, it may be objected, if all the work done in compression is converted into heat, and if this heat is got rid of as soon as possible, then the work may be virtually thrown away, and the compressed air can have no more energy than it had before compression. It is true that the compressed gas has no more energy than the gas had before compression, if its temperature is no higher, but the advantage of the compression lies in bringing its energy into more available form.

The total energy of the compressed and uncompressed gas is the same at the same temperature, but the available energy is much greater in the former.

When the compressed air is used in driving a rock-drill, or any other piece of machinery, it gives up energy equal in amount to the work it does, and its temperature is accordingly greatly reduced.

**Causes of Loss of Energy in Use of Compressed Air.** (Zahner, on Transmission of Power by Compressed Air.) — 1. The compression of air always develops heat, and as the compressed air always cools down to the temperature of the surrounding atmosphere before it is used, the mechanical equivalent of this dissipated heat is work lost.

2. The heat of compression increases the volume of the air, and hence it is necessary to carry the air to a higher pressure in the compressor in order that we may finally have a given volume of air at a given pressure, and at the temperature of the surrounding atmosphere. The work spent in effecting this excess of pressure is work lost.

3. Friction of the air in the pipes, leakage, dead spaces, the resistance offered by the valves, insufficiency of valve-area, inferior workmanship, and slovenly attendance, are all more or less serious causes of loss of power.

The first cause of loss of work, namely, the heat developed by compression, is entirely unavoidable. The whole of the mechanical energy which the compressor-piston spends upon the air is converted into heat. This heat is dissipated by conduction and radiation, and its mechanical equivalent is work lost. The compressed air, having again reached thermal

equilibrium with the surrounding atmosphere, expands and does work in an air motor, losing temperature and intrinsic energy in proportion to the work done.

A large fall in temperature will cause any moisture in the air to freeze, and, unless the air is pre-heated before use in the motor, permitting it to expand to more than two volumes will cause difficulties. It is for this reason, and also because of the heat-losses in the compressor, that the lower the pressure at which compressed air is used for power transmission the more efficient is the system. Against the increased efficiencies of the lower pressures must be balanced the higher cost of the mechanisms, on account of size, to utilize the lower pressures.

The intrinsic energy of any gas is the energy which it is capable of exerting against a piston in changing from a given state as to temperature and volume to a total privation of heat and indefinite expansion. The intrinsic energy of 1 lb. of gas at any pressure and volume is the product of its absolute temperature and its specific heat at constant volume. (See Thermodynamics.)

**Loss due to Excess of Pressure caused by Heating in the Compression-cylinder.** — If the air during compression were kept at a constant temperature, the compression-curve of an indicator-diagram taken from the cylinder would be an isothermal curve, and would follow the law

of Boyle and Mariotte,  $p v = a$  constant, or  $p_1 v_1 = p_0 v_0$ , or  $p_1 = p_0 \frac{v_0}{v_1}$ ,  $p_0 v_0$

being the pressure and volume at the beginning of compression, and  $p_1 v_1$  the pressure and volume at the end, or at any intermediate point. But as the air is heated during compression the pressure increases faster than the volume decreases, causing the work required for any given pressure to be increased. If none of the heat were abstracted by radiation or by injection of water, the curve of the diagram would be an adiabatic

curve, with the equation  $p_1 = p_0 \left( \frac{v_0}{v_1} \right)^{1.405}$ . Cooling the air during compression, or compressing it in two cylinders, called compounding, and

cooling the air as it passes from one cylinder to the other, reduces the exponent of this equation, and reduces the quantity of work necessary to effect a given compression. F. T. Gause (*Am. Mach.*, Oct. 20, 1892), describing the operations of the Popp air-compressors in Paris, says: The greatest saving realized in compressing in a single cylinder was 33 per cent of that theoretically possible. In cards taken from the 2000 H.P. compound compressor at Quai De La Gare, Paris, the saving realized is 85 per cent of the theoretical amount. Of this amount only 8 per cent is due to cooling during compression, so that the increase of economy in the compound compressor is mainly due to cooling the air between the two stages of compression. A compression-curve with exponent 1.25 is the best result that was obtained for compression in a single cylinder and cooling with a very fine spray. The curve with exponent 1.15 is that which must be realized in a single cylinder to equal the present economy of the compound compressor at Quai De La Gare.

**Adiabatic and Isothermal Compression.**—Theoretically, air may be compressed adiabatically, in which case all the heat of compression is retained in the air, or isothermally, in which case the heat of compression is removed as rapidly as it is generated, by some refrigerating process. Adiabatic compression is impossible as some of the heat will be radiated into the compressor walls, and isothermal compression is practically impossible, as the heat must be generated before it can be absorbed. The best practical results that have been obtained by compressing air in a single stage compressor make it possible to save approximately one-third of the loss due to the heat generated in the compressor.

#### Formulae for Adiabatic Compression or Expansion of Air (or Other Sensibly Perfect Gas).

Let air at an absolute temperature  $T_1$ , absolute pressure  $p_1$ , and volume  $v_1$  be compressed to an absolute pressure  $p_2$  and corresponding volume  $v_2$  and absolute temperature  $T_2$ ; or let compressed air of an initial pressure, volume, and temperature  $p_1$ ,  $v_1$ , and  $T_1$ , there being no transmission of heat from or into the air during the operation

Then the following equations express the relations between pressure, volume, and temperature (see works on Thermodynamics):

$$\frac{v_1}{v_2} = \left(\frac{p_2}{p_1}\right)^{0.71}; \quad \frac{p_2}{p_1} = \left(\frac{v_1}{v_2}\right)^{1.41}; \quad \frac{v_1}{v_2} = \left(\frac{T_2}{T_1}\right)^{2.46};$$

$$\frac{T_2}{T_1} = \left(\frac{v_1}{v_2}\right)^{0.41}; \quad \frac{T_2}{T_1} = \left(\frac{p_2}{p_1}\right)^{0.29}; \quad \frac{p_2}{p_1} = \left(\frac{T_2}{T_1}\right)^{3.46}.$$

The exponents are derived from the ratio  $c_p \div c_v = k$  of the specific heats of air at constant pressure and constant volume. Taking  $k = 1.406$ ,  $1 \div k = 0.711$ ;  $k - 1 = 0.406$ ;  $1 \div (k - 1) = 2.463$ ;  $k + (k - 1) = 3.463$ ;  $(k - 1) \div k = 0.289$ .

**Work of Adiabatic Compression of Air.** — If air is compressed in a cylinder without clearance from a volume  $v_1$  and pressure  $p_1$  to a smaller volume  $v_2$  and higher pressure  $p_2$ , work equal to  $p_1 v_1$  is done by the external air on the piston while the air is drawn into the cylinder. Work is then done by the piston on the air, first, in compressing it to the pressure  $p_2$  and volume  $v_2$ , and then in expelling the volume  $v_2$  from the cylinder against the pressure  $p_2$ . If the compression is adiabatic,  $p_1 v_1^k = p_2 v_2^k = \text{constant}$ .  $k = 1.406$ .

The work of compression of a given quantity of air is, in foot-pounds,

$$\frac{p_1 v_1}{k - 1} \left\{ \left(\frac{v_1}{v_2}\right)^{k-1} - 1 \right\} = \frac{p_1 v_1}{k - 1} \left\{ \left(\frac{p_2}{p_1}\right)^{\frac{k-1}{k}} - 1 \right\},$$

or  $2.463 p_1 v_1 \left\{ \left(\frac{v_1}{v_2}\right)^{0.41} - 1 \right\} = 2.463 p_1 v_1 \left\{ \left(\frac{p_2}{p_1}\right)^{0.29} - 1 \right\}.$

The work of expulsion is  $p_2 v_2 = p_1 v_1 \left(\frac{p_2}{p_1}\right)^{0.29}$ .

The total work is the sum of the work of compression and expulsion less the work done on the piston during admission, and it equals

$$p_1 v_1 \left\{ \frac{k}{k - 1} \right\} \left\{ \left(\frac{p_2}{p_1}\right)^{\frac{k-1}{k}} - 1 \right\} = 3.463 p_1 v_1 \left\{ \left(\frac{p_2}{p_1}\right)^{0.29} - 1 \right\}.$$

The mean effective pressure during the stroke is

$$p_1 \frac{k}{k - 1} \left\{ \left(\frac{p_2}{p_1}\right)^{\frac{k-1}{k}} - 1 \right\} = 3.463 p_1 \left\{ \left(\frac{p_2}{p_1}\right)^{0.29} - 1 \right\}.$$

$p_1$  and  $p_2$  are absolute pressures above a vacuum, in pounds per square foot.

**EXAMPLE.** — Required the work done in compressing 1 cubic foot of air per second from 1 to 6 atmospheres, including the work of expulsion from the cylinder.

$p_2 \div p_1 = 6$ ;  $6^{0.29} - 1 = 0.681$ ;  $3.463 \times 0.681 = 2.358$  atmospheres  $\times 14.7 = 34.66$  lb. per sq. in. mean effective pressure,  $\times 144 = 4991$  lb. per sq. ft.,  $\times 1$  ft. stroke = 4991 ft.-lb.,  $\div 550$  ft.-lb. per second = 9.08 H.P.

If  $R$  = ratio of pressures =  $p_2 \div p_1$ , and if  $v_1 = 1$  cubic foot, the work done in compressing 1 cubic foot from  $p_1$  to  $p_2$  is, in foot-pounds,

$$3.463 p_1 (R^{0.29} - 1),$$

$p_1$  being taken in lb. per sq. ft. For compression at the sea level  $p_1$  may be taken at 14 lbs. per sq. in. = 2016 lb. per sq. ft., as there is some loss of pressure due to friction of valves and passages.

Horse-power required to compress and deliver 100 cubic feet of free air per minute =  $1.511 P_1 (R^{0.29} - 1)$ ;  $P_1$  being the pressure of the free air in pounds per sq. in., absolute.

**EXAMPLE.** To compress 100 cu. ft. from 1 to 6 atmospheres.  $P_1 = 14.7$ ;  $R = 6$ ;  $1.511 \times 14.7 \times 0.681 = 15.13$  H.P.

Indicator-cards from compressors in good condition and under working-speeds usually follow the adiabatic line closely. A low curve indicates piston leakage. Such cooling as there may be from the cylinder-jacket and the re-expansion of the air in clearance-spaces tends to reduce the



mean effective pressure, while the "camel-backs" in the expulsion-line, due to resistance to opening of the discharge-valve, tend to increase it.

Work of one stroke of a compressor, with adiabatic compression, in foot-pounds,

$$W = 3.463 P_1 V_1 (R^{0.29} - 1).$$

in which  $P_1$  = initial absolute pressure in lb. per sq. ft. and  $V_1$  = volume traversed by piston in cubic feet.

The work done during adiabatic compression (or expansion) of 1 pound of air from a volume  $v_1$  and pressure  $p_1$  to another volume  $v_2$  and pressure  $p_2$  is equal to the mechanical equivalent of the heating (or cooling). If  $t_1$  is the higher and  $t_2$  the lower temperature, Fahr., the work done is  $c_v J (t_1 - t_2)$  foot-pounds,  $c_v$  being the specific heat of air at constant volume = 0.1689, and  $J = 778$ ,  $c_v J = 131.4$ .

The work during compression also equals

$$\frac{c_v J}{R_a} p_1 v_1 \left[ \left( \frac{p_2}{p_1} \right)^{0.29} - 1 \right] = 2.463 p_1 v_1 \left[ \left( \frac{p_2}{p_1} \right)^{0.29} - 1 \right],$$

$R_a$  being the value of  $p v \div$  absolute temperature for 1 lb. of air = 53.32.

The work during expansion is

$$2.463 p_1 v_1 \left[ 1 - \left( \frac{p_2}{p_1} \right)^{0.29} \right] = 2.463 p_2 v_2 \left[ \left( \frac{p_1}{p_2} \right)^{0.29} - 1 \right],$$

in which  $p_1 v_1$  are the initial and  $p_2 v_2$  the final pressures and volumes.

**Compound Compression, with Air Cooled between the Two Cylinders.** (*Am. Mach.*, March 10 and 31, 1898.) — Work in low-pressure cylinder =  $W_1$ , in high-pressure cylinder  $W_2$ . Total work

$$W_1 + W_2 = 3.46 P_1 V_1 [r_1^{0.29} + R^{0.29} \times r_1^{-0.29} - 2].$$

$r_1$  = ratio of pressures in l. p. cyl.,  $r_2$  = ratio in h.p. cyl.,  $R = r_1 r_2$ . When  $r_1 = r_2 = \sqrt{R}$ , the sum  $W_1 + W_2$  is a minimum. Hence for a given total ratio of pressures,  $R$ , the work of compression, will be least when the ratios of the pressures in each of the two cylinders are equal.

The equation may be simplified, when  $r_1 = \sqrt{R}$ , to the following:

$$W_1 + W_2 = 6.92 P_1 V_1 [R^{0.145} - 1].$$

Dividing by  $V_1$  gives the mean effective pressure reduced to the low-pressure cylinder M.E.P. =  $6.92 P_1 [R^{0.145} - 1]$ .

In the above equation the compression in each cylinder is supposed to be adiabatic, but the intercooler is supposed to reduce the temperature of the air to that at which compression began.

Horse-power required to compress adiabatically 100 cu. ft. of free air per minute in two stages with intercooling, and with equal ratio of compression in each cylinder, =  $3.022 P_1 (R^{0.145} - 1)$ ;  $P_1$  being the pressure in lbs. per sq. in., absolute, of the free air, and  $R$  the total ratio of compression.

EXAMPLE. To compress 100 cu. ft. per min. from 1 to 6 atmospheres,  $P = 14.7$ ;  $R = 6$ ;  $3.022 \times 14.7 \times 0.2964 = 13.17$  H.P.

**Mean Effective Pressures of Air Compressed in Two Stages, assuming the Intercooler to Reduce the Temperature to that at which Compression Began.** (F. A. Halsey, *Am. Mach.*, Mar. 31, 1898.)

$R$ .	$R^{0.145}$ .	M.E.P. from 14 lbs. Initial.	Ultimate Saving by Compound-ing, %.	$R$ .	$R^{0.145}$ .	M.E.P. from 14 lbs. Initial.	Ultimate Saving by Com pound-ing, %.
5.0	1.263	25.4	11.5	9.0	1.375	36.3	15.8
5.5	1.280	27.0	12.3	9.5	1.386	37.3	16.2
6.0	1.296	28.6	12.8	10	1.396	38.3	16.6
6.5	1.312	30.1	13.2	11	1.416	40.2	17.2
7.0	1.326	31.5	13.7	12	1.434	41.9	17.8
7.5	1.336	32.8	14.3	13	1.451	43.5	18.4
8.0	1.352	34.0	14.8	14	1.466	45.0	19.0
8.5	1.364	35.2	15.3	15	1.481	46.4	19.4

$R$  = final  $\div$  initial absolute pressure.

M.E.P. = mean effective pressure, lb. per sq. in., based on 14 lb. absolute initial pressure reduced to the low-pressure cylinder.

To find the Index of the Curve of an Air-diagram. If  $P_1V_1$  be pressure and volume at one point on the curve, and  $PV$  the pressure and volume at another point, then  $\frac{P}{P_1} = \left(\frac{V_1}{V}\right)^x$ , in which  $x$  is the index to be found. Let  $P \div P_1 = R$ , and  $V_1 \div V = r$ ; then  $R = r^x$ ;  $\log R = x \log r$ , whence  $x = \log R \div \log r$ . (See also graphic method on page 602.)

**Pressures, Volumes, Mean Effective Pressures, and Final Temperatures, in Single-stage Compression from 1 Atmosphere and 60° Fahr.**  
(Contributed by M. C. Wilkinson, San Pedro, Cal., 1914.)

Pressure.			Volume.			M. E. P. of Stroke		Final Temperature.	
Gage.	Absolute.	Atmospheres.	Constant Temperature.	Exponent $K = 1.25$ (best practice).	Exponent $K = 1.41$ (adiabatic).	Exponent $K = 1.25$	Exponent $K = 1.41$	Exponent $K = 1.25$	Exponent $K = 1.41$
1	2	3	4	5	6	7	8	9	10
0	14.7	1.0	1.0000	1.000	1.000	0.000	0.000	60.0	60.0
1	15.7	1.068	0.9363	0.948	0.954	0.974	0.982	66.3	70.0
2	16.7	1.136	.8803	.903	.910	1.896	1.913	73.4	79.6
3	17.7	1.204	.8305	.862	.876	2.778	2.810	79.7	88.8
4	18.7	1.272	.7862	.825	.841	3.624	3.681	85.6	97.6
5	19.7	1.340	.7463	.791	.812	4.432	4.510	91.7	106.1
10	24.7	1.680	.5952	.660	.692	8.041	8.267	116.9	144.5
15	29.7	2.020	.4950	.570	.607	11.099	11.515	138.5	177.7
20	34.7	2.360	.4237	.503	.544	13.774	14.396	157.5	207.1
25	39.7	2.701	.3702	.452	.494	16.155	16.998	174.3	233.6
30	44.7	3.041	.3288	.411	.454	18.309	19.375	189.5	257.9
35	49.7	3.381	.2955	.377	.421	20.259	21.569	203.5	280.3
40	54.7	3.721	.2687	.349	.393	22.101	23.610	216.3	301.2
45	59.7	4.061	.2462	.326	.370	23.777	25.529	228.2	320.8
50	64.7	4.401	.2272	.303	.349	25.358	27.331	239.4	339.2
55	69.7	4.742	.2109	.288	.329	26.842	29.037	249.9	356.7
60	74.7	5.082	.1968	.272	.315	28.239	30.661	259.8	373.2
65	79.7	5.422	.1844	.258	.301	29.562	32.808	269.2	388.9
70	84.7	5.762	.1736	.247	.288	30.826	33.680	278.1	404.0
75	89.7	6.102	.1639	.235	.277	32.031	35.105	286.6	418.6
80	94.7	6.442	.1552	.225	.266	33.185	36.469	294.8	432.5
85	99.7	6.782	.1474	.216	.257	34.288	37.782	302.6	446.0
90	104.7	7.122	.1404	.208	.248	35.346	39.050	310.1	458.9
95	109.7	7.463	.1340	.200	.240	36.368	40.277	317.3	471.4
100	114.7	7.803	.1282	.192	.233	37.354	41.463	324.3	483.5
105	119.7	8.143	.1228	.186	.226	38.401	42.613	331.0	495.3
110	124.7	8.483	.1179	.181	.219	39.220	43.728	337.5	506.7
115	129.7	8.823	.1133	.175	.213	40.109	44.813	343.8	517.8
120	134.7	9.163	.1091	.170	.207	40.969	45.866	349.9	528.6
125	139.7	9.503	.1052	.165	.202	41.807	46.900	355.8	539.1
130	144.7	9.844	.1015	.160	.197	42.623	47.898	361.6	549.3
135	149.7	10.184	.0982	.156	.192	43.416	48.880	367.2	559.3
140	154.7	10.524	.0950	.152	.188	44.189	49.832	372.6	569.0
145	159.7	10.864	.0921	.148	.184	44.938	50.769	377.9	578.6
150	164.7	11.204	.0893	.145	.180	45.766	51.681	383.1	587.9
160	174.7	11.884	.0841	.138	.172	47.084	53.451	393.1	606.0
170	184.7	12.565	.0796	.132	.166	48.429	55.147	402.7	623.3
180	194.7	13.245	.0755	.126	.160	49.723	56.781	411.8	641.0
190	204.7	13.925	.0718	.121	.154	50.968	58.359	420.6	656.1
200	214.7	14.605	.0685	.117	.147	52.156	59.881	429.0	671.7

Columns 1, 2 and 3 give the relative pressure readings in gage, absolute and atmospheric pressures.

Column 4 gives the relative volumes of the air after compression and with the temperature reduced to 60° F. These are the volumes that are available for use in the operation of the driven mechanisms.

Column 5 gives the relative volumes of the air as the compressor has to deal with it.

Column 7 gives the mean effective pressures of a single stroke of the compressor, including the compression and expulsion of air from the cylinder. In computing the power required to operate the compressor a certain percentage (usually from 5 to 20) must be added for mechanical friction and valve resistance and other compressor characteristics.

Column 9 gives the temperature of the air as it leaves the compressor.

Columns 6, 8 and 10 give the theoretical, final volumes, mean effective pressures and final temperatures of air compressed adiabatically.

**Mean Effective Pressures of Air Compressed Adiabatically.**

(F. A. Halsey, *Am. Mach.*, Mar. 10, 1898.)

R.	$R^{0.29}$ .	M.E.P. from 14 lbs. Initial.	R.	$R^{0.29}$ .	M.E.P. from 14 lbs. Initial.
1.25	1.067	3.24	4.75	1.570	27.5
1.50	1.125	6.04	5	1.594	28.7
1.75	1.176	8.51	5.25	1.617	29.8
2	1.223	10.8	5.5	1.639	30.8
2.25	1.265	12.8	5.75	1.660	31.8
2.5	1.304	14.7	6	1.681	32.8
2.75	1.341	16.4	6.25	1.701	33.8
3	1.375	18.1	6.5	1.720	34.7
3.25	1.407	19.6	6.75	1.739	35.6
3.5	1.438	21.1	7	1.757	36.5
3.75	1.467	22.5	7.25	1.775	37.4
4	1.495	23.9	7.5	1.793	38.3
4.25	1.521	25.2	8	1.827	39.9
4.5	1.546	26.4			

$R$  = final ÷ initial absolute pressure.

M.E.P. = mean effective pressure, lb. per sq. in., based on 14 lb. initial.

**Horse-power required to compress and deliver One Cubic Foot of Free Air per minute to a given pressure with no cooling of the air during the compression; also the horse power required, supposing the air to be maintained at constant temperature during the compression.**

**H.P. required to compress and deliver One Cubic Foot of Compressed Air per minute at a given pressure (the air being measured at the atmospheric temperature) with no cooling of the air during the compression; also supposing the air to be maintained at constant temperature during the compression.**

Gauge-pressure.	Air not cooled.	Air constant temperature.
5	0.0196	0.0188
10	0.0361	0.0333
20	0.0628	0.0551
30	0.0846	0.0713
40	0.1032	0.0843
50	0.1195	0.0946
60	0.1342	0.1036
70	0.1476	0.1120
80	0.1599	0.1195
90	0.1710	0.1261
100	0.1815	0.1318

Gauge-pressure.	Air not cooled.	Air constant temperature.
5	0.0263	0.0251
10	0.0606	0.0559
20	0.1483	0.1300
30	0.2573	0.2168
40	0.3842	0.3138
50	0.5261	0.4166
60	0.6818	0.5266
70	0.8508	0.6456
80	1.0302	0.7700
90	1.2177	0.8979
100	1.4171	1.0291

The horse-power given above is the theoretical power, no allowance being made for friction of the compressor or other losses, which may amount to 10 per cent or more.



**Compressed-air Engines, Adiabatic Expansion.** — Let the initial pressure and volume taken into the cylinder be  $p_1$  lb. per sq. ft. and  $v_1$  cubic feet; let expansion take place to  $p_2$  and  $v_2$  according to the adiabatic law  $p_1 v_1^{1.41} = p_2 v_2^{1.41}$ ; then at the end of the stroke let the pressure drop to the back-pressure  $p_3$ , at which the air is exhausted. Assuming no clearance, the work done by one pound of air during admission, measured above vacuum, is  $p_1 v_1$ , the work during expansion is  $2.463 p_1 v_1 \left[ 1 - \left( \frac{p_2}{p_1} \right)^{0.29} \right]$ , and the negative or back pressure work is  $-p_3 v_2$ . The total work is  $p_1 v_1 + 2.463 p_1 v_1 \left[ 1 - \left( \frac{p_2}{p_1} \right)^{0.29} \right] - p_3 v_2$ , and the mean effective pressure is the total work divided by  $v_2$ .

If the air is expanded down to the back-pressure  $p_3$  the total work is

$$3.463 p_1 v_1 \left\{ 1 - \left( \frac{p_3}{p_1} \right)^{0.29} \right\},$$

or, in terms of the final pressure and volume,

$$3.463 p_3 v_2 \left\{ \left( \frac{p_1}{p_3} \right)^{0.29} - 1 \right\}.$$

and the mean effective pressure is

$$3.463 p_3 \left\{ \left( \frac{p_1}{p_3} \right)^{0.29} - 1 \right\}.$$

The actual work is reduced by clearance. When this is considered, the product of the initial pressure  $p_1$  by the clearance volume is to be subtracted from the total work calculated from the initial volume  $v_1$ , including clearance. (See p. 961 under "Steam-engine.")

**Mean and Terminal Pressures of Compressed Air used Expansively for Gauge Pressures from 60 to 100 lb.**

(Frank Richards, *Am. Mach.*, April 13, 1893.)

Point of Cut-off.	Initial Pressure.									
	60		70		80		90		100	
	Mean Air-pressure.	Terminal Air-pressure.	Mean Air-pressure.	Terminal Air-pressure.	Mean Air-pressure.	Terminal Air-pressure.	Mean Air-pressure.	Terminal Air-pressure.	Mean Air-pressure.	Terminal Air-pressure.
.25	23.6	<i>10.65</i>	28.74	<i>12.07</i>	33.89	<i>13.49</i>	39.04	<i>14.91</i>	44.19	1.33
.30	28.9	<i>13.77</i>	34.75	0.6	40.61	2.44	46.46	4.27	53.32	6.11
	32.13	0.96	38.41	3.09	44.69	5.22	50.98	7.35	57.26	9.48
.35	33.66	2.33	40.15	4.38	46.64	6.66	53.13	8.95	59.62	11.23
	35.85	3.85	42.63	6.36	49.41	7.88	56.2	11.39	62.98	13.89
.40	37.93	5.64	44.99	8.39	52.05	11.14	59.11	13.88	66.16	16.64
.45	41.75	10.71	49.31	12.61	56.9	15.86	64.45	19.11	72.02	22.36
.50	45.14	13.26	53.16	17.	61.18	20.81	69.19	24.56	77.21	28.33
.60	50.75	21.53	59.51	26.4	68.28	31.27	77.05	36.14	85.82	41.01
	51.92	23.69	60.84	28.85	69.76	34.01	78.69	39.16	87.61	44.32
	53.67	27.94	62.83	33.03	71.99	38.68	81.14	44.33	90.32	49.97
.70	54.93	30.39	64.25	36.44	73.57	42.49	82.9	48.54	92.22	54.59
.75	56.52	35.01	66.05	41.68	75.59	48.35	85.12	55.02	94.66	61.69
.80	57.79	39.78	67.5	47.08	77.2	54.38	86.91	61.69	96.61	68.99
	59.15	47.14	69.03	55.43	78.92	63.81	88.81	72.	98.7	80.28
.90	59.46	49.65	69.38	58.27	79.31	66.89	89.24	75.52	99.17	87.82

Pressures in italics are absolute; all others are gage pressures

**AIR COMPRESSION AT ALTITUDES.**

(Ingersoll-Rand Co. Copyright, 1906, by F. M. Hitchcock.)

**Multipliers to Determine the Volume of Free Air which, when Compressed, is Equivalent in Effect to a Given Volume of Free Air at Sea Level.**

Altitude, Feet.	Barometric Pressure.		Gauge Pressure (Pounds).				
	In. of Mercury.	Lb. per Sq. In.	60	80	100	125	150
1,000	28.88	14.20	1.032	1.033	1.034	1.035	1.036
2,000	27.80	13.67	1.064	1.066	1.068	1.071	1.072
3,000	26.76	13.16	1.097	1.102	1.105	1.107	1.109
4,000	25.76	12.67	1.132	1.139	1.142	1.147	1.149
5,000	24.79	12.20	1.168	1.178	1.182	1.187	1.190
6,000	23.86	11.73	1.206	1.218	1.224	1.231	1.234
7,000	22.97	11.30	1.245	1.258	1.267	1.274	1.278
8,000	22.11	10.87	1.287	1.300	1.310	1.319	1.326
9,000	21.29	10.46	1.329	1.346	1.356	1.366	1.374
10,000	20.49	10.07	1.373	1.394	1.404	1.416	1.424

**Horse-power Developed in Compressing One Cubic Foot of Free Air at Various Altitudes from Atmospheric to Various Pressures.**

Initial Temperature of the Air in Each Cylinder Taken as 60° F.; Jacket Cooling not Considered; Allowance made for usual losses.

Altitude, Feet.	Simple Compression.			Two Stage Compression.				
	Gauge Pressure (Pounds).			Gauge Pressure (Pounds).				
	60	80	100	60	80	100	125	150
0	0.1533	0.1824	0.2075	0.1354	0.1580	0.1765	0.1964	0.2138
1,000	0.1511	0.1795	0.2040	0.1332	0.1553	0.1734	0.1926	0.2093
2,000	0.1489	0.1766	0.2006	0.1310	0.1524	0.1700	0.1887	0.2048
3,000	0.1469	0.1739	0.1971	0.1286	0.1493	0.1666	0.1848	0.2003
4,000	0.1448	0.1712	0.1939	0.1263	0.1464	0.1635	0.1810	0.1963
5,000	0.1425	0.1685	0.1906	0.1241	0.1438	0.1600	0.1772	0.1921
6,000	0.1402	0.1656	0.1872	0.1218	0.1409	0.1566	0.1737	0.1879
7,000	0.1379	0.1628	0.1839	0.1197	0.1383	0.1536	0.1700	0.1838
8,000	0.1358	0.1600	0.1807	0.1173	0.1358	0.1504	0.1662	0.1797
9,000	0.1337	0.1572	0.1774	0.1151	0.1329	0.1473	0.1627	0.1758
10,000	0.1316	0.1547	0.1743	0.1132	0.1303	0.1442	0.1592	0.1717

**EXAMPLE.**— Required the volume of free air which when compressed to 100 lb. gauge at 9,000 ft. altitude will be equivalent to 1,000 cu. ft. of free air at sea level; also the power developed in compressing this volume to 100 lb. gauge in two stage compression at this altitude.

From first table the multiplier is 1.356. Equivalent free air = 1,000 × 1.356 = 1,356 cu. ft.

From second table, power developed in compressing 1 cu. ft. of free air is 0.1473 H.P.; 1,356 × 0.1473 = 199.73 H.P.

**The Popp Compressed-air System in Paris.**— A most extensive system of distribution of power by means of compressed air is that of M. Popp, in Paris. One of the central stations is laid out for 24,000 horse-power. For a very complete description of the system, see *Engineering*, Feb. 15, June 7, 21, and 28, 1889, and March 13 and 20, April 10, and May 1, 1891. Also *Proc. Inst. M. E.*, July, 1889. A condensed description will be found in *Modern Mechanism*, p. 12.

**Utilization of Compressed Air in Small Motors.**— In the earliest stages of the Popp system in Paris it was recognized that no good results

could be obtained if the air were allowed to expand direct into the motor; not only did the formation of ice due to the expansion of the air rapidly accumulate and choke the exhaust, but the percentage of useful work obtained, compared with that put into the air at the central station, was so small as to render commercial results hopeless.

After a number of experiments M. Popp adopted a simple form of cast-iron stove lined with fire-clay, heated either by a gas jet or by a small coke fire. This apparatus answered the desired purpose until a better arrangement was perfected, and the type was accordingly adopted throughout the whole system. The economy resulting from the use of the improved form was very marked.

It was found that more than 70% of the total heating value of the fuel employed was absorbed by the air and transformed into useful work. The efficiency of fuel consumed in this way is at least six times greater than when utilized in a boiler and steam-engine. According to Prof. Riedler, from 15% to 20% above the power at the central station can be obtained by means at the disposal of the power users. By heating the air to 480° F. an increased efficiency of 30% can be obtained.

A large number of motors in use among the subscribers to the Compressed Air Company of Paris are rotary engines developing 1 H.P. and less, and these in the early times of the industry were very extravagant in their consumption. Small rotary engines, working cold air without expansion, used as high as 2330 cu. ft. of air per brake H.P. per hour, and with heated air 1624 cu. ft. Working expansively, a 1-H.P. rotary engine used 1469 cu. ft. of cold air, or 960 cu. ft. of heated air, and a 2-H.P. rotary engine 1059 cu. ft. of cold air, or 847 cu. ft. of air, heated to about 122° F.

The efficiency of this type of rotary motors, with air heated to 122° F., may now be assumed at 43%.

Tests of a small Riedinger rotary engine, used for driving sewing-machines and indicating about 0.1 H.P., showed an air-consumption of 1377 cu. ft. per H.P. per hour when the initial pressure of the air was 86 lb. per sq. in. and its temperature 54° F., and 988 cu. ft. when the air was heated to 338° F., its pressure being 72 lb. With a 1/2-H.P. variable-expansion rotary engine the air-consumption was from 800 to 900 cu. ft. per H.P. per hour for initial pressures of 54 to 85 lb. per sq. in. with the air heated from 336° to 388° F., and 1148 cu. ft. with cold air, 46° F., and an initial pressure of 72 lb. The volumes of air were all taken at atmospheric pressure.

Trials made with an old single-cylinder 80-horse-power Farcot steam-engine, indicating 72 H.P., gave a consumption of air per brake H.P. as low as 465 cu. ft. per hour. The temperature of admission was 320° F., and of exhaust 95° F.

Prof. Elliott gives the following as typical results of efficiency for various systems of compressors and air-motors:

Simple compressor and simple motor, efficiency . . . . . 39.1%

Compound compressor and simple motor, " . . . . . 44.9

" " compound motor, efficiency.. 50.7

Triple compressor and triple motor, efficiency . . . . . 55.3

The efficiency is the ratio of the I.H.P. in the motor cylinders to the I.H.P. in the steam-cylinders of the compressor. The pressure assumed is 6 atmospheres absolute, and the losses are equal to those found in Paris over a distance of 4 miles.

#### Summary of Efficiencies of Compressed-air Transmission at Paris, between the Central Station at St. Fargeau and a 10-horse-power Motor Working with Pressure Reduced to 4 1/2 Atmospheres.

(The figures below correspond to mean results of two experiments cold and two heated.)

One indicated horse-power at central station gives 0.845 I.H.P. in compressors, and corresponds to the compression of 348 cu. ft. of air per hour from atmospheric pressure to 6 atmospheres absolute.

0.845 I.H.P. in compressors delivers as much air as will do 0.52 I.H.P. in adiabatic expansion after it has fallen to the normal temperature of the mains.

The fall of pressure in mains between central station and Paris (say 5 kilometres) reduces the possibility of work from 0.52 to 0.51 I.H.P.



The further fall of pressure through the reducing valve to 4½ atmospheres (absolute) reduces the possibility of work from 0.51 to 0.50.

Incomplete expansion, wire-drawing, and other such causes reduce the actual I.H.P. of the motor from 0.50 to 0.39.

By heating the air before it enters the motor to about 320° F., the actual I.H.P. at the motor is, however, increased to 0.54. The ratio of gain by heating the air is, therefore,  $0.54 \div 0.39 = 1.38$ .

In this process additional heat is supplied by the combustion of about 0.39 lb. of coke per I.H.P. per hour, and if this be taken into account, the real indicated efficiency of the whole process becomes 0.47 instead of 0.54.

Working with cold air the work spent in driving the motor itself reduces the available horse-power from 0.39 to 0.26.

Working with heated air the work spent in driving the motor itself reduces the available horse-power from 0.54 to 0.44.

A summary of the efficiencies is as follows:

Efficiency of main engines 0.845.

Efficiency of compressors  $0.52 \div 0.845 = 0.61$ .

Efficiency of transmission through mains  $0.51 \div 0.52 = 0.98$ .

Efficiency of reducing valve  $0.50 \div 0.51 = 0.98$ .

The combined efficiency of the mains and reducing valve between 5 and 4½ atmospheres is thus  $0.98 \times 0.98 = 0.96$ . If the reduction had been to 4, 3½, or 3 atmospheres, the corresponding efficiencies would have been 0.93, 0.89, and 0.85 respectively.

Indicated efficiency of motor  $0.39 \div 0.50 = 0.78$ .

Indicated efficiency of whole process with cold air 0.39. Apparent indicated efficiency of whole process with heated air 0.54.

Real indicated efficiency of whole process with heated air 0.47.

Mechanical efficiency of motor, cold, 0.67.

Mechanical efficiency of motor, hot, 0.81.

**Ingersoll-Rand Co.'s Air Compressors.\***

**STRAIGHT LINE POWER-DRIVEN COMPRESSORS, CLASS "ER-1."  
Air Pressure 10 to 125 Pounds per sq. in.**

Cylinders, Inches.		Piston Displacement Cu.ft. per Min.	Air Pres. Designed for Lb. Gage.	Brake H.P. at Motor, including Belt Loss.	Cylinders, Inches.		Piston Displacement Cu.ft. per Min.	Air Pres. Designed for Lb. Gage.	Brake H.P. at Motor, including Belt Loss.
Diam.	Stroke.				Diam.	Stroke.			
6	6	52	80-125	8	10	210	80-125	33-38	
7	6	72	50-100	9½	12	304	50-100	38-50	
8	6	94	25- 50	9½	14	415	20- 50	32-50	
9	6	121	10- 25	10	17	615	10- 20	27-48	
12	6	215	10-	15	-				
8	8	113	80-125	17	12	340	80-125	54-61	
9	8	145	60-100	19½	14	464	45-100	53-73	
10	8	179	25- 60	18	17	688	30- 45	55-73	
12	8	258	15- 25	20½	20	955	15- 30	35-70	
14	8	354	10- 15	21	-25				

Stroke, inches.....	6	8	10	12
Revolutions per minute..	275	250	235	220
Belt wheel.....	36 × 5½	45 × 8½	58 × 10½	72 × 14½

These machines are also built for steam-drive.

\* These tables are considerably abridged from the originals, and show only the small and medium-sized machines. Large machines up to 8,500 cu. ft. capacity are made, usually of special designs.

**"IMPERIAL XB-1" DUPLEX POWER-DRIVEN COMPRESSORS.**  
Air Pressure, 15 to 100 Pounds per sq. in.

Diam. Duplex Air Cylinders, in.	Stroke, Inches.	Piston Displacement Cu. Ft. Free Air per Min.	Air Pressure Designed for	Brake H.P. Required at Belt Wheel.	Diam. Duplex Air Cylinder.	Stroke, Inches.	Piston Displacement Cu. Ft. Free Air per Min.	Air Pressure Designed for	Brake H.P. Required at Belt Wheel.
7	10	198	60-100	27-37	14	14	916	35-40	93-102
8	10	258	40-55	29-35	16	14	1198	25-30	99-112
9	10	327	27-35	27-34	18	14	1518	15-20	87-108
10	10	405	22-25	29-33					
11	10	491	15-20	28-35	13	16	826	80-100	135-154
					14	16	959	65-75	142-155
8	12	289	75-100	47-55	15	16	1103	45-60	129-155
9	12	367	55-70	50-58	17	16	1419	30-40	129-158
10	12	454	40-50	51-58	19	16	1775	20-25	123-145
11	12	549	27-35	46-57	21	16	2171	15-20	126-157
12	12	655	22-25	47-54					
13	12	770	15-20	44-55	15	16a	1100	80-100	181-206
					16	16a	1253	55-75	188-202
9	12a	365	85-100	62-69	18	16a	1592	35-50	161-205
10	12a	453	60-80	64-75	21	16a	2168	25-30	177-202
11	12a	549	47-55	66-74	24	16a	2836	15-20	162-202
12	12a	654	37-45	67-78					
13	12a	769	25-35	63-80	15	20	1254	75-100	197-232
15	12a	1025	15-20	58-72	17	20	1615	50-70	204-251
					19	20	2020	35-45	214-242
11	14	563	80-100	94-106	22	20	2714	25-30	223-255
12	14	671	60-75	95-108	25	20	3508	15-20	203-253
13	14	789	45-55	94-106					

Stroke of cylinder, in..	10	12	12a	14	16	16a	20
Revolutions per min..	225	210	210	185	170	170	155
Belt wheel, diameter in.	54	60	72	84	96	96	108
Belt wheel, face in....	8 1/2	10 1/2	12 1/2	16 1/2	20 1/2	28 1/2	31 1/2

**"IMPERIAL XB-2" TWO-STAGE POWER-DRIVEN AIR COMPRESSORS.**  
For air pressure of 80 to 100 pounds per sq. in.—For sea level.

Diameter of Air Cylinders, Inches			Rev. per Min.	Piston Displacement, Cu. Ft. Free Air per Min.	Brake H.P. Required at Belt Wheel.		Belt Wheel.	
Low Press.	High Press.	Stroke.			Air Pressure.		Diam., Inches.	Face, Inches.
					80	100		
10	6 1/2	10	225	203	32	36	54	8 1/2
12	7 1/2	12	210	327	50	57	60	10 1/2
14	9	12	210	445	68	76	72	12 1/2
16	10	14	185	599	92	104	84	16 1/2
19	12	16	170	888	135	152	96	20 1/2
22	13	16	170	1190	183	206	96	28 1/2
23	14	20	155	1482	225	254	108	31 1/2

For 5,000 feet altitude the low-pressure cylinders are made 1 inch larger diameter, and for 10,000 feet altitude 2 inches larger.

**"IMPERIAL X-2" DUPLEX STEAM-DRIVEN TWO-STAGE AIR COMPRESSORS.**

Air cylinders of the same dimensions as the XB-2 compressors. The duplex steam cylinders have diameters 7, 8, 9, 10, 12, and 14 inches. The 14 × 20-inch cylinder is designed for 150 r. p. m.

DUPLEX STEAM-DRIVEN "IMPERIAL X-1" COMPRESSORS.

For air pressures of 15 to 100 lb. per sq. in.—Steam, 80 to 120 lb.

Cylinder Diam., In.			R. P. M.	Piston Displacement Cu.Ft. Free Air per Min.	Air Pressure Designed for	I.H.P. in Steam Cylinders.	Cylinder Diam., In.			R. P. M.	Piston Displacement Cu.Ft. Free Air per Min.	Air Pressure Designed for	I.H.P. in Steam Cylinders.
Duplex Steam.	Duplex Air.	Stroke.					Duplex Steam.	Duplex Air.	Stroke.				
7	7	10	225	198	60-100	28-38	10	14	14	185	916	35-40	96-105
7	8	10	225	258	40-55	30-36	10	16	14	185	1198	25-30	103-116
7	9	10	225	327	27-35	27-34	10	18	14	185	1518	15-20	90-112
7	10	10	225	405	22-25	29-34							
7	11	10	225	491	15-20	29-36	12	13	16	170	826	80-100	141-161
							12	14	16	170	959	65-75	149-162
8	8	12	210	289	75-100	48-57	12	15	16	170	1103	45-60	135-163
8	9	12	210	367	55-70	51-60	12	17	16	170	1419	30-40	135-165
8	10	12	210	454	40-50	53-61	12	19	16	170	1775	20-25	128-151
8	11	12	210	549	27-35	46-59	12	21	16	170	2171	15-20	131-164
8	12	12	210	655	22-25	47-56							
8	13	12	210	770	15-20	46-57	14	15	16	170	1100	80-100	186-212
							14	16	16	170	1253	55-75	173-209
9	9	12	210	365	85-100	65-72	14	18	16	170	1592	35-50	166-212
9	10	12	210	453	60-80	67-79	14	21	16	170	2168	25-30	183-208
9	11	12	210	549	47-55	69-78	14	24	16	170	2836	15-20	168-209
9	12	12	210	654	37-45	69-81							
9	13	12	210	769	25-35	66-84	14	15	20	150	1213	75-100	196-232
9	15	12	210	1025	15-20	61-76	14	17	20	150	1562	50-70	204-251
							14	19	20	150	1955	35-45	204-242
10	11	14	185	563	80-100	98-110	14	22	20	150	2626	25-30	224-255
10	12	14	185	671	60-75	98-112	14	25	20	150	3395	15-20	203-253
10	13	14	185	789	45-55	97-110							

COMPOUND STEAM CYLINDERS FOR "IMPERIAL X" COMPRESSORS.

For substituting in place of Duplex Steam Cylinders in the "Imperial X-1 and X-2" Tables for Steam-Pressures of 100 to 120 Lbs. Condensing or Non-Condensing.

Compound Engines with Plain "D" Steam Valves.			Compound Engines with Meyer Cut-off Valves.		
Standard Duplex Steam Cylinders.	Standard Compound Steam Cylinders.	Stroke.	Standard Duplex Steam Cylinders.	Standard Compound Steam Cylinders.	Stroke.
7 & 7	7 & 11	10	10 & 10	12 & 19	14
8 & 8	8 & 13	12	12 & 12	14 & 22	16
9 & 9	10 & 16	12	14 & 14	16 & 25	16
			14 & 14	16 & 25	20

**Tests of Power-driven Air Compressors.**—R. L. Webb, Portland, Ore., has furnished the author with a copy of a complete report of a test made by him in 1912, of three air compressors, two of them 18 in. diam. X 12 in. stroke, rated at 1000 cu. ft. per min. displacement, and the third 22 X 12 in., rated at 1500 cu. ft. Nos. 1 and 3 were designed for 35 to 45 lb. gage-pressure and No. 2 for 15 to 20 lb. The compressors were driven by 500 volt d.c. shunt, commutating pole motors, with a speed range of 2 to 1, through Link-Belt silent chain drives, 2 in. pitch, 9 in. wide, chain speed, 1600 ft. per min., pinions 17 and 64 teeth, chain gear efficiency about 98%; gear submerged in oil. The speed control was regulated by the air pressure. The air delivered was measured



by the orifice method, using Fliegner's equation. The results of the tests are summarized in the table below:

## TESTS OF AIR COMPRESSORS.

Revs. per Min.	Displacement, Cu. Ft. per Min.	Output, Cu. Ft. per Min.	Volumetric Efficiency, Per cent.	Electrical Input, K.W.	Electrical Horse-power.	Indicated Horse-power.	I. H.P., % E.H.P.	Lbs. Gage Pressure.
----------------	--------------------------------	--------------------------	----------------------------------	------------------------	-------------------------	------------------------	-------------------	---------------------

## Compressor No. 1, 18 × 12 in.

71.6	502.1	412.3	82.11	45.6	61.2	51.75	84.5	44.6
102.0	715.3	597.4	83.2	67.7	90.7	75.28	83.0	44.5
143.0	1002.8	873.3	87.1	87.1	133.4	106.73	80.0	44.2

## Compressor No. 2, 22 × 12 in.

70.7	749.8	657.1	85.6	42.1	56.4	48.3	85.7	19.6
103.8	1100.8	986.0	89.5	65.0	87.1	73.1	83.0	19.2
141.0	1495.3	1333.9	89.2	97.6	130.8	106.5	80.0	19.5

## Compressor No. 3, 18 × 12 in.

70.2	492.3	371.1	75.4	43.9	58.8	50.0	85.0	44.8
101.0	708.3	567.2	80.1	65.8	88.3	73.4	84.0	44.7
145.0	1016.9	837.1	82.3	100.7	135.0	109.1	80.7	44.4

**Steam Required to Compress 100 Cu. Ft. of Free Air.** (O. S. Shantz, *Power*, Feb. 4, 1908.) — The following tables show the number of pounds of steam required to compress 100 cu. ft. of free air to different gauge pressures, by means of steam engines using from 12 to 40 lbs. of steam per I.H.P. per hour. The figures assume adiabatic compression in the air cylinders, with intercooling to atmospheric temperature in the case of two-stage compression, and 90% mechanical efficiency of the compressor.

## STEAM CONSUMPTION OF AIR COMPRESSORS—SINGLE-STAGE COMPRESSION.

Air Gage Pressure.	Steam per I.H.P. Hour. Lb.												
	12	14	16	18	20	22	24	26	28	30	32	36	40
20	1.36	1.58	1.82	2.04	2.26	2.49	2.72	2.94	3.17	3.40	3.61	4.08	4.54
30	1.84	2.14	2.45	2.76	3.06	3.37	3.68	3.98	4.29	4.60	4.90	5.51	6.12
40	2.26	2.64	3.02	3.39	3.77	4.15	4.52	4.90	5.26	5.65	6.03	6.78	7.50
50	2.62	3.06	3.50	3.93	4.36	4.80	5.25	5.68	6.10	6.55	7.00	8.86	8.71
60	2.92	3.41	3.90	4.38	4.80	5.36	5.85	6.32	6.80	7.30	7.80	8.76	9.71
70	3.22	3.76	4.30	4.83	5.36	5.90	6.45	6.97	7.50	8.05	8.60	9.66	10.70
80	3.50	4.08	4.67	5.25	5.84	6.42	7.00	7.59	8.15	8.75	9.34	10.50	11.61
90	3.72	4.34	4.96	5.58	6.20	6.82	7.45	8.05	8.66	9.30	9.94	11.15	12.35
100	3.96	4.61	5.29	5.95	6.60	7.25	7.92	8.58	9.22	9.90	10.56	11.88	13.15
110	4.18	4.87	5.58	6.26	6.96	7.66	8.36	9.05	9.75	10.45	11.15	12.52	13.90
120	4.38	5.11	5.85	6.57	7.30	8.04	8.76	9.50	10.20	10.95	11.66	13.13	14.55

## TWO-STAGE COMPRESSION.

70	2.82	3.25	3.76	4.23	4.69	5.16	5.63	6.10	6.56	7.04	7.50	8.45	9.35
80	3.01	3.51	4.03	4.52	5.02	5.53	6.03	6.53	7.03	7.53	8.03	9.05	10.01
90	3.19	3.72	4.26	4.79	5.32	5.85	6.38	6.91	7.44	7.98	8.50	9.57	10.60
100	3.37	3.93	4.50	5.05	5.61	6.19	6.74	7.30	7.85	8.42	8.99	10.10	11.20
110	3.54	4.14	4.74	5.32	5.91	6.51	7.10	7.70	8.27	8.86	9.46	10.64	11.80
120	3.69	4.30	4.93	5.54	6.15	6.78	7.38	8.00	8.61	9.24	9.85	11.05	12.27
130	3.83	4.46	5.11	5.75	6.38	7.03	7.66	8.30	8.92	9.57	10.20	11.48	12.72
140	3.96	4.62	5.29	5.94	6.60	7.26	7.92	8.60	9.23	9.90	10.56	11.88	13.15
150	4.10	4.76	5.46	6.14	6.81	7.50	8.17	8.86	9.55	10.20	10.90	12.26	13.60

**Cubic Feet of Air Required to Run Rock Drills at Various Pressures and Altitudes.**

(Ingersoll-Rand Co., 1908.)

TABLE I. — CUBIC FEET OF FREE AIR REQUIRED TO RUN ONE DRILL.

Gauge Pressure, Lb. per Sq. In.	Size and Cylinder Diameter of Drill.												
	A 35	A 32 A 86	B	C	D	D	D	E	F	F	G	H	H 9
	2"	2 1/4"	2 1/2"	2 3/4"	3"	3 1/8"	3 3/16"	3 1/4"	3 1/2"	3 5/8"	4 1/4"	5"	5 1/2"
60	50	60	68	82	90	95	97	100	108	113	130	150	164
70	56	68	77	93	102	108	110	113	124	129	147	170	181
80	63	76	86	104	114	120	123	127	131	143	164	190	207
90	70	84	95	115	126	133	136	141	152	159	182	210	230
100	77	92	104	126	138	146	149	154	166	174	199	240	252

TABLE II. — MULTIPLIERS TO GIVE CAPACITY OF COMPRESSOR TO OPERATE FROM 1 TO 70 ROCK DRILLS AT VARIOUS ALTITUDES.

Altitude Above Sea Level.	Number of Drills.															
	1	2	3	4	5	6	7	8	9	10	15	20	25	30	40	50
0	1.	1.8	2.7	3.4	4.1	4.8	5.4	6.0	6.5	7.1	9.5	11.7	13.7	15.8	21.4	25.5
1000	1.03	1.85	2.78	3.5	4.22	4.94	5.56	6.18	6.69	7.3	9.78	12.05	14.1	16.3	22.0	26.26
2000	1.07	1.92	2.89	3.64	4.39	5.14	5.78	6.42	6.95	7.60	10.17	12.52	14.66	16.9	22.9	27.28
3000	1.10	1.98	2.97	3.74	4.51	5.28	5.94	6.6	7.15	7.81	10.45	12.87	15.07	17.38	23.54	28.05
5000	1.17	2.10	3.16	3.98	4.8	5.62	6.32	7.02	7.61	8.31	11.12	13.69	16.03	18.49	25.04	29.84
8000	1.26	2.27	3.40	4.28	5.17	6.05	6.8	7.56	8.19	8.95	11.97	14.74	17.26	19.9	26.96	32.13
10000	1.32	2.38	3.56	4.49	5.41	6.34	7.13	7.92	8.58	9.37	12.54	15.44	18.08	20.86	28.25	33.66
15000	1.43	2.57	3.86	4.86	5.86	6.86	7.72	8.58	9.3	10.15	13.58	16.73	19.59	22.59	30.6	36.49

EXAMPLE. — Required the amount of free air to operate thirty 5-inch "H" drills at 8,000 ft. altitude, using air at a gauge pressure of 80 lb. per sq. in. From Table I, we find that one 5-inch "H" drill operating at 80 lb. gauge pressure requires 190 cu. ft. of free air per minute. From Table II, the factor for 30 drills at 8,000 feet altitude is 19.9;  $190 \times 19.9 = 3781$  = the displacement of a compressor under average conditions, to which must be added pipe line losses.

The tables above are for fair conditions in ordinary hard rock. In soft material, where the drilling time is short more drills can be run with a given compressor than when working in hard material. In tunnel work, more rapid progress can be made if the drills are run at high air pressure, and it is advisable to have an excess of compressor capacity of about 25%. No allowance has been made in the tables for friction of pipe line losses.

**Compressed-air Table for Pumping Plants.**

(Ingersoll-Rand Co., 1908.)

The following table shows the pressure and volume of air required for any size pump for pumping by compressed air. Reasonable allowances have been made for loss due to clearances in pump and friction in pipe.

To find the amount of air and pressure required to pump a given quantity of water a given height, find the ratio of diameters between water and air cylinders, and multiply the number of gallons of water by the

figure found in the column for the required lift. The result is the number of cubic feet of free air. The pressure required on the pump will be found directly above in the same column. For example: The ratio between cylinders being 2 to 1, required to pump 100 gallons, height of lift 250 feet. We find under 250 feet at ratio 2 to 1 the figures 2.11;  $2.11 \times 100 = 211$  cubic feet of free air. The pressure required is 34.38 pounds delivered at the pump piston.

Ratio of Diameters.		Perpendicular Height, in Feet, to which the Water is to be Pumped.										
		25	50	75	100	125	150	175	200	250	300	400
1 to 1	A	13.75	27.5	41.25	55.0	68.25	82.5	96.25	110.0	.....	.....	.....
	B	0.21	0.45	0.60	0.75	0.89	1.04	1.20	1.34	.....	.....	.....
1 1/2 to 1	A	.....	12.22	18.33	24.44	30.33	36.66	42.76	48.88	61.11	73.32	97.66
	B	.....	0.65	0.80	0.95	1.09	1.24	1.39	1.53	1.83	2.12	2.70
1 3/4 to 1	A	.....	.....	13.75	19.8	22.8	27.5	32.1	36.66	45.83	55.0	73.33
	B	.....	.....	0.94	1.14	1.24	1.30	1.54	1.69	1.99	2.39	2.88
2 to 1	A	.....	.....	.....	13.75	17.19	20.63	24.06	27.5	34.38	41.25	55.0
	B	.....	.....	.....	1.23	1.37	1.52	1.66	1.81	2.11	2.40	2.98
2 1/4 to 1	A	.....	.....	.....	.....	13.75	16.5	19.25	22.0	27.5	33.0	44.0
	B	.....	.....	.....	.....	1.53	1.68	1.83	1.97	2.26	2.56	3.15
2 1/2 to 1	A	.....	.....	.....	.....	.....	13.2	15.4	17.6	22.0	26.4	35.2
	B	.....	.....	.....	.....	.....	1.79	1.98	2.06	2.34	2.62	3.18

A = air-pressure at pump. B = cubic feet of free air per gallon of water.

### Compressed-air Table for Hoisting-engines.

(Ingersoll-Rand Co., 1908.)

The following table gives an approximate idea of the volume of free air required for operating hoisting-engines, the air being delivered to the engine at 60 lbs. gauge. There are so many variable conditions to the operation of hoisting-engines in common use that accurate computations can only be offered when fixed data are given. In the table the engine is assumed to actually run but one-half of the time for hoisting, while the compressor runs continuously. If the engine runs less than one-half the time, the volume of air required will be proportionately less, and *vice versa*. The table is computed for maximum loads, which also in practice may vary widely. From the intermittent character of the work of a hoisting-engine the parts are able to resume their normal temperature between the hoists, and there is little probability of freezing up the exhaust-passages.

### Volume of Free Air Required for Operating Hoisting-engines, the Air Compressed to 60 Pounds Gauge Pressure.

#### SINGLE-CYLINDER HOISTING-ENGINE.

Diam. of Cylinder, Inches.	Stroke, Inches.	Revolutions per Minute.	Normal Horse-power.	Actual Horse-power.	Weight Lifted, Single Rope.	Cubic Ft. of Free Air Required.
5	6	200	3	5.9	600	75
5	8	160	4	6.3	1,000	80
6 1/4	8	160	6	9.9	1,500	125
7	10	125	10	12.1	2,000	151
8 1/4	10	125	15	16.8	3,000	170
8 1/2	12	110	20	18.9	5,000	238
10	12	110	25	26.2	6,000	330



## DOUBLE-CYLINDER HOISTING-ENGINE.

Diam. of Cylinder, Inches.	Stroke, Inches.	Revolutions per Minute.	Normal Horse-power.	Actual Horse-power.	Weight Lifted, Single Rope.	Cubic Ft. of Free Air Required.
5	6	200	6	11.8	1,000	150
5	8	160	8	12.6	1,650	160
6 1/4	8	160	12	19.8	2,500	250
7	10	125	20	24.2	3,500	302
8 1/4	10	125	30	33.6	6,000	340
8 1/2	12	110	40	37.8	8,000	476
10	12	110	50	52.4	10,000	660
12 1/4	15	100	75	89.2	.....	1,125
14	18	90	100	125.	.....	1,587

**Practical Results with Compressed Air.** — *Compressed-air System at the Chapin Mines, Iron Mountain, Mich.* — These mines are three miles from the falls which supply the power. There are four turbines at the falls, one of 1000 horse-power and three of 900 horse-power each. The pressure is 60 pounds at 50° Fahr. Each turbine runs a pair of compressors. The pipe to the mines is 24 ins. diameter. The power is applied at the mines to Corliss engines, running pumps, hoists, etc., and direct to rock-drills.

A test made in 1888 gave 1430.27 H.P. at the compressors, and 390.17 H.P. as the sum of the horse-power of the engines at the mines. Therefore, only 27% of the power generated was recovered at the mines. This includes the loss due to leakage and the loss of energy in heat, but not the friction in the engines or compressors. (F. A. Pocock, *Trans. A. I. M. E.*, 1890.)

W. L. Saunders (*Jour. F. I.*, 1892) says: "There is not a properly designed compressed-air installation in operation to-day that loses over 5% by transmission alone. The question is altogether one of the size of pipe; and if the pipe is large enough, the friction loss is a small item.

"The loss of power in common practice, where compressed air is used to drive machinery in mines and tunnels, is about 70%. In the best practice, with the best air-compressors, and without reheating, the loss is about 60%. These losses may be reduced to a point as low as 20% by combining the best systems of reheating with the best air-compressors."

**Gain due to Reheating.** — Prof. Kennedy says compressed-air transmission system is now being carried on, on a large commercial scale, in such a fashion that a small motor four miles away from the central station can indicate in round numbers 10 horse-power, for 20 horse-power at the station itself, allowing for the value of the coke used in heating the air.

The limit to successful reheating lies in the fact that air-engines cannot work to advantage at temperatures over 350°.

The efficiency of the common system of reheating is shown by the results obtained with the Popp system in Paris. Air is admitted to the reheater at about 83°, and passes to the engine at about 315°, thus being increased in volume about 42%. The air used in Paris is about 11 cubic feet of free air per minute per horse-power. The ordinary practice in America with cold air is from 15 to 25 cubic feet per minute per horse-power. When the Paris engines were worked without reheating the air consumption was increased to about 15 cubic feet per horse-power per minute. The amount of fuel consumed during reheating is trifling.

**Effect of Temperature of Intake upon the Discharge of a Compressor.** — Air should be drawn from outside the engine-room, and from as cool a place as possible. The gain in efficiency amounts to one per cent for every five degrees that the air is taken in lower than the temperature of the engine-room. The inlet conduit should have an area at least 50% of the area of the air-piston, and should be made of wood, brick, or other non-conductor of heat.

Discharge of a compressor having an intake capacity of 1000 cubic feet per minute, and volumes of the discharge reduced to cubic feet at atmospheric pressure and at temperature of 62 degrees Fahrenheit:

Temperature of Intake, F. . . . 0° 32° 62° 75° 80° 90° 100° 110°  
Volume discharged, cubic ft. 1135 1060 1000 975 966 949 932 916

**Compressed-Air Motors with a Return Air Circuit.**—In the ordinary use of motors, such as rock-drills, the air, after doing its work in the motor, is allowed to escape into the atmosphere. In some systems, however, notably in the electric air-drill, the air exhausted from the cylinder of the motor is returned to the air compressor. A marked increase in economy is claimed to have been effected in this way (*Cass. Mag.*, 1907).

**Intercoolers for Air Compressors.**—H. V. Haight (*Am. Mach.*, Aug. 30, 1906). In multi-stage air compressors, the efficiency is greater the more nearly the temperature of the air leaving the intercooler approaches that of the water entering it. The difference of these temperatures for given temperatures of the entering water and air is diminished by increasing the surface of the intercooler and thereby decreasing the ratio of the quantity of air cooled to the area of cooling surface. Numerous tests of intercoolers with different ratios of quantity of air to area of surface, on being plotted, approximate to a straight-line diagram, from which the following figures are taken.

Cu. ft. of free air per min. per sq. ft. of air cooling surface    5    10    15  
Diff. of temp. F° between water entering and air leaving    12.5°    25°    37.5°

**Centrifugal Air Compressors.**—The General Electric Company has placed on the market a line of single stage centrifugal air compressors with pressure ratings from 0.75 to 4 lb. per sq. in., and capacity from 500 to 10,000 cu. ft. of free air per min. The compressor consists essentially of a rotating impeller surrounded by a rigid cast-iron casing and suitable conversion nozzles to convert velocity of the air into pressure. It is similar to the centrifugal pump, efficiency depending entirely upon the design of the passages throughout the machine.

The compressors are driven by Curtis steam-turbines or by electric motors specially designed for them. The induction motors used are of the squirrel-cage type which do not permit any variation in the speed and care must be taken to specify a pressure sufficiently high to cover the operating requirements, because the pressure cannot be varied at constant speed without altering the design of the impeller. The pressure of the D. C. motor-driven unit can be changed by changing the speed of the motor by means of the field rheostat.

Motor Rating H.P.	Standard Designs, 3450 r.p.m.		Off-Standard Designs, 3450 r.p.m.		Off-Standard Designs, 3850 r.p.m.		Pipe Diam.. Inches.
	Lb. per Sq. In.	Cu. Ft. per Min.	Lb. per Sq. In.	Cu. Ft. per Min.	Lb. per Sq. In.	Cu. Ft. per Min.	
5	1	800	0.75	1,100	1.25	600	10
10	1	1,600	0.75	2,100	1.25	1,300	12
20	1	3,200	0.75	4,100	1.25	2,600	16
30	1	4,500	0.75	5,900	1.25	3,800	20
50	1	7,200	0.75	8,800	1.25	6,000	20
75	1	10,200	0.75	12,000	1.25	8,700	26
10	2	750	1.5	1,000	2.50	500	8
20	2	1,600	1.5	2,100	2.50	1,200	10
30	2	2,500	1.5	3,300	2.50	1,900	12
50	2	4,200	1.5	5,400	2.50	3,300	16
75	2	6,200	1.5	8,000	2.50	5,000	20
30	3.25	1,250	2.5	1,800	4.00	900	8
50	3.25	2,400	2.5	3,200	4.00	1,900	12
75	3.25	3,800	2.5	5,000	4.00	3,000	14

Multi-stage compressors have been built in the following sizes:

Cubic feet free air per minute. . . . . 4,500    9,000    16,000    25,000    40,000    50,000.  
Pressure, pounds per square inch. . . 6 to 35    6 to 25    8 to 25    12 to 30    12 to 30    12 to 30  
As in the case of centrifugal pumps, the pressure depends upon the

peripheral velocity of the impeller. The volume of free air delivered is limited, however, by the capacity of the driver. It must never be operated without being piped to a load sufficient to restrict the flow of air to the rated value, otherwise the driver will become seriously overloaded.

The power required to drive the centrifugal compressor varies approximately with the volume of air delivered when operating at a constant speed, between the limits of 50 per cent and 125 per cent of the rated load. This gives flexibility and economy to the centrifugal type where variable volumetric loads are required.

When the compressor is operating as an exhauster discharging against atmospheric pressure, the rated pressure  $P$ , in lb. per sq. in., must be multiplied by 14.7 and then divided by 14.7 plus  $P$  to obtain the vacuum in lbs. per sq. in. below atmosphere. The rated pressures are given for an atmospheric pressure of 14.7 lb. per sq. in. and a temperature of 60° F. When the compressors are operated at an altitude, the pressure will be reduced directly in proportion to the barometric pressure. For other temperatures, the pressures will be inversely proportioned to the absolute temperature, or  $P \times 520 \div (460 + T^\circ)$ . When operated on gas the rated pressure is to be corrected by multiplying it by the relative density of the gas, taking air = 1. A large number of machines have been installed to operate on illuminating gas, by-product coke oven gas, or producer gas. Constant suction governors controlling the speed of the turbine drivers are employed where close control of the suction head is desired, as in the case of gas exhausters.

Ten large machines (2000 to 5000 H.P.) for blowing blast furnaces have also been installed. These have steam turbines for drivers and are controlled by constant volume governors, giving a constant speed, so that a definite volume of air per minute is delivered, regardless of the resistance of the furnace.

**High-Pressure Centrifugal Fans.** — (A. Rateau, *Engg.*, Aug. 16, 1907.) In 1900, a single wheel fan driven by a steam turbine at 20,200 revs. per min. gave an air pressure of  $8\frac{1}{4}$  lbs. per sq. in.; an output of 26.7 cu. ft. free air per second; useful work in H.P. adiabatic compression, 45.5; theoretical work in H.P. of steam-flow, 162; efficiency of the set, fan and turbine, 28%. An efficiency of 30.7% was obtained with an output of 23 cu. ft. per sec. and 132 theoretical H.P. of steam. The pressure obtained with a fan is — all things being equal — proportional to the specific weight of the gas which flows through it; therefore, if, instead of air at atmospheric pressure, air, the pressure of which has already been raised, or a gas of higher density, such as carbonic acid, be used, comparatively higher pressures still will be obtained, or the engine can run at lower speeds for the same increase of pressure.

**Multiple Wheel Fans.** — The apparatus having a single impeller gives satisfaction only when the duty and speed are sufficiently high. The speed is limited by the resistance of the metal of which the impeller is made, and also by the speed of the motor driving the fan. But by connecting several fans in series, as is done with high-lift centrifugal pumps, it is possible to obtain as high a pressure as may be desired.

**Turbo-Compressor, Bethune Mines, 1906.** — This machine compresses air to 6 and 7 atmospheres by utilizing the exhaust steam from the winding-engines. It consists of four sets of multi-cellular fans through which the air flows in succession. They are fitted on two parallel shafts, and each shaft is driven by a low-pressure turbine. A high-pressure turbine is also mounted on one of the shafts, but supplies no work in ordinary times. An automatic device divides the load equally between the two shafts. Between the two compressors are fitted refrigerators, in which cold water is made to circulate by the action of a small centrifugal pump keyed at the end of the shaft. In tests at a speed of 5000 r.p.m., the volume of air drawn per second was 31.7 cu. ft. and the discharge pressure 119.5 lb. per sq. in. absolute. These conditions of working correspond to an effective work in isothermal compression of 252 H.P. The efficiency of the compressor has been as high as 70%. The results of two tests of the compressor are given below. In the first test the air discharged, reduced to atmospheric pressure, was 26 cu. ft. per sec.; in the second test it was 46 cu. ft.



## FIRST TEST.

Stages.	1st.	2d.	3d.	4th.
Abs. pressure at inlet, lbs. per sq. in. ...	15.18	23.37	38.69	66.44
Abs. pressure at discharge .....	24.10	39.98	66.44	102.60
Speed, revs. per min. ....	4660	4660	4660	4660
Temperature of air at inlet, deg. F. ...	57.2	67.8	63.	66.
Temperature of air at discharge, deg. F. 171.	205.	216.	215.6	
Adiabatic rise in temp., deg. F. ....	106.	122.	114.8	105.8
Actual rise in temperature, deg. F. ...	113.8	137.2	153.	149.6
Efficiency, per cent .....	60.5	60.5	54.	46.2

## SECOND TEST.

Stages.	1st.	2d.	3d.	4th.
Abs. pressure at inlet, lbs. per sq. in. ...	15.18	21.31	37.33	65.12
Abs. pressure at discharge .....	23.52	38.22	65.12	99.66
Speed, revs. per min. ....	5000	5000	4840	4840
Temp. of air at inlet, deg. F. ....	55.	69.8	64.4	68.5
Temp. of air at discharge, deg. F. ....	160.7	208.4	208.4	199.6
Adiabatic rise in temp., deg. F. ....	102.2	131.	123.8	100.4
Efficiency, per cent .....	62.3	66.6	58.7	48.6

The Gutehoffnungshütte Co. in Germany have in course of construction several centrifugal blowing-machines to be driven by an electric motor, and up to 2000 H.P. Several machines are now being designed for Bessemer converters, some of which will develop up to 4000 H.P. The multicellular centrifugal compressors are identical in every point with centrifugal pumps. In the new machines cooling water is introduced inside the diaphragms, which are built hollow for this purpose, and also inside the diffuser vanes. By this means it is hoped to reduce proportionally the heating of the air; thus approaching isothermal compression much more nearly than is done in the case of reciprocating compressors.

**Test of a Hydraulic Air Compressor.** — (W. O. Webber, *Trans. A. S. M. E.*, xxii, 599.) The compressor embodies the principles of the old trompe used in connection with the Catalan forges some centuries ago, modified according to principles first described by J. P. Frizell, in *Jour. F. I.*, Sept., 1880, and improved by Charles H. Taylor, of Montreal. (Patent July 23, 1895.) It consists principally of a down-flow passage having an enlarged chamber at the bottom and an enlarged tank at the top. A series of small air pipes project into the mouth of the water inlet and the large chamber at the upper end of the vertically descending passage, so as to cause a number of small jets of air to be entrained by the water. At the lower end of the apparatus, deflector plates in connection with a gradually enlarging section of the lower end of the down-flow pipe are used to decrease the velocity of the air and water, and cause a partial separation to take place. The deflector plates change the direction of the flow of the water and are intended to facilitate the escape of the air, the water then passing out at the bottom of the enlarged chamber into an ascending shaft, maintaining upon the air a pressure due to the height of the water in the uptake, the compressed air being led on from the top of the enlarged chamber by means of a pipe. The general dimensions of the compressor plant are:

Supply penstock, 60 ins. diam.; supply tank at top, 8 ft. diam. × 10 ft. high; air inlets (feeding numerous small tubes), 34 2-in. pipes; down tube, 44 ins. diam.; down tube, at lower end, 60 ins. diam.; length of taper in down tube, 20 ft.; air chamber in lower end of shaft, 16 ft. diam.; total depth of shaft below normal level of head water, about 150 ft.; normal head and fall, about 22 ft.; air discharge pipe, 7 ins. diam.

It is used to supply power to engines for operating the printing department of the Dominion Cotton Mills, Magog, P. Q., Canada.

There were three series of tests, viz.: (1) Three tests at different rates of flow of water, the compressor being as originally constructed. (2) Four tests at different rates of flow of water, the compressor inlet tubes for air being increased by 30 3/4-in. pipes. (3) Four tests at different rates of flow of water, the compressor inlet tubes for air being increased by 15 3/4-in. pipes.

The water used was measured by a weir, and the compressed air by air meters. The table on p. 623 shows the principal results:

Test 1, when the flow was about 3800 cu. ft. per min., showed a decided advantage by the use of 30 3/4-in. extra air inlet pipes. Test 5 shows, when the flow of water is about 4200 cu. ft. per min., that the economy is highest when only 15 extra air tubes are employed. Tests 8 and 9 show, when the flow is about 4600 cu. ft. per min., that there is no advantage in increasing the air-inlet area. Tests 10 and 11 show that a flow of 5000 or more cu. ft. of water is in excess of the capacity of the plant. These four tests may be summarized as follows:

The tests show: (1) That the most economic rate of flow of water with this particular installation is about 4300 cu. ft. per min. (2) That this plant has shown an efficiency of 70.7 % under such a flow, which is excellent for a first installation. (3) That the compressed air contains only from 30 to 20% as much moisture as does the atmosphere. (4) That the air is compressed at the temperature of the water.

Using an old Corliss engine without any changes in the valve gear as a motor there was recovered 81 H.P. This would represent a total efficiency of work recovered from the falling water, of 51.2%. When the compressed air was preheated to 267° F. before being used in the engine, 111 H.P. was recovered, using 115 lbs. coke per hour, which would equal about 23 H.P. The efficiency of work recovered from the falling water and the fuel burned would be, therefore, about 61 1/2%. On the basis of Prof. Riedler's experiments, which require only about 425 cu. ft. of air per B.H.P. per hour, when preheated to 300° F. and used in a hot-air jacketed cylinder, the total efficiency secured would have been about 87 1/2%.

Test No.....	1	3	4	5	7	8	10
Flow of water, cu. ft. per min...	3772	3628	4066	4,292	4408	4700	5058
Available head in ft.....	20.54	20.00	20.35	19.51	19.93	19.31	18.75
Gross water, H.P.....	146.3	136.9	156.2	158.1	165.8	171.4	179.1
Cu. ft. air, at atmos. press., per minute.....	864	901	967	1148	1091	1103	1165
Pressure of air at comp., lbs.....	51.9	53.7	53.2	53.3	53.7	52.9	53.3
Effective work in compressing, H.P.....	83.3	88.2	94.3	111.74	107	106.8	113.4
Efficiency of compressor, %.....	56.8	64.4	60.3	70.7	64.5	62.2	63.3
Temp. of external air, deg. F....	68.3	57.7	66.4	65.2	59.7	65	64.2
Temp. of water and comp. air, deg. F.....	66	65.5	66.4	66.5	67	66.5	66
Ratio of water to air, volumes...	4.37	4.03	4.20	3.74	4.04	4.26	4.34
Moisture in external air, p. c. of saturation.....	61	77.5	71	68	90	60.5	63
Moisture in comp. air, p. c. of saturation.....	51.5	44	38.5	35	29	31.2	30

Tests 1, 4, and 7 were made with the original air inlets; 2, 5, 8 and 10 with the inlets increased by 15 3/4-in. pipes, and 3, 6, 9 and 11 with the inlets increased by 30 3/4-in. pipes. Tests 2, 6, 9 and 11 are omitted here. They gave, respectively, 55.5, 61.3, 62, and 55.4% efficiency.

Three other hydraulic air-compressor plants are mentioned in Mr. Webber's paper, some of the principal data of which are given below:

	Peterboro, Ont.	Norwich, Conn.	Cascade Range, Wash.
Head of water .....	14 ft.	18 1/2 ft.	45 ft.
Gauge pressure.....	25 lbs.	85 lbs.	85 lbs.
Diam. of shaft .....	42 in.	24 ft.	...
Diam. of compressor pipe.....	18 ft.	13 ft.	3 ft.
Depth below tailrace .....	64 ft.	215 ft.	...
Horse-power .....	...	1365	200

In the Cascade Range plant there is no shaft, as the apparatus is constructed against the vertical walls of a canyon. The diameter of the up-flow pipe is 4 ft. 9 in.

A description of the Norwich plant is given by J. Herbert Shedd in a paper read before the New England Water Works Assn., 1905 (*Compressed Air*, April, 1906). The shaft, 24 ft. diam., is enlarged at the bottom into a chamber 52 ft. diam., from which leads an air reservoir 100 ft. long, 18 ft. wide and 15 to 20 ft. high. Suspended in the shaft is a downflow pipe 14 ft. diam. connected at the top with a head tank, and at the bottom with the air-chamber, from which a 16-in. main conveys the air four miles to Norwich, where it is used in engines in several establishments.

**The Mekarski Compressed-air Tramway at Berne, Switzerland.** (*Eng'g News*, April 20, 1893.) — The Mekarski system has been introduced in Berne, Switzerland, on a line about two miles long, with grades of 0.25% to 3.7% and 5.2%. The air is heated by passing it through superheated water at 330° F. It thus becomes saturated with steam, which subsequently partly condenses, its latent heat being absorbed by the expanding air. The pressure in the car reservoirs is 440 lb. per sq. in.

The engine is constructed like an ordinary steam tramway locomotive, and drives two coupled axles, the wheel-base being 5.2 ft. It has a pair of outside horizontal cylinders, 5.1 × 8.6 in.; four coupled wheels, 27.5 in. diameter. The total weight of the car, including compressed air, is 7.25 tons, and with 30 passengers, including the driver and conductor, about 9.5 tons. The authorized speed is about 7 miles per hour.

The disadvantages of this system consist in the extremely delicate adjustment of the different parts of the system, in the comparatively small supply of air carried by one motor car, which necessitates the car returning to the depot for refilling after a run of only four miles or 40 minutes, although on the Nogent and Paris lines the cars, which are, moreover, larger, and carry outside passengers on the top, run seven miles, and the loading pressure is 547 lb. per sq. in. as against only 440 lb. at Berne.

For description of the Mekarski system as used at Nantes, France, see paper by Prof. D. S. Jacobus, *Trans. A. S. M. E.*, xix. 553.

**American Experiments on Compressed Air for Street Railways.** — Experiments have been made in Washington, D. C., and in New York City on the use of compressed air for street-railway traction. The air was compressed to 2000 lb. per sq. in. and passed through a reducing-valve and a heater before being admitted to the engine. The system has since been abandoned. For an extended discussion of the relative merits of compressed air and electric traction, with an account of a test of a four-stage compressor giving a pressure of 2500 lb. per sq. in., see *Eng'g News*, Oct. 7 and Nov. 4, 1897. A summarized statement of the probable efficiency of compressed-air traction is given as follows: Efficiency of compression to 2000 lb. per sq. in. 65%. By wire-drawing to 100 lbs. 57.5% of the available energy of the air will be lost, leaving  $65 \times 0.425 = 27.625\%$  as the net efficiency of the air. This may be doubled by heating, making 55.25%, and if the motor has an efficiency of 80% the net efficiency of traction by compressed air will be  $55.25 \times 0.80 = 44.2\%$ . For a description of the Hardie compressed-air locomotive, designed for street-railway work, see *Eng'g News*, June 24, 1897. For use of compressed air in mine haulage, see *Eng'g News*, Feb. 10, 1898.

**Operation of Mine Pumps by Compressed Air.** — The advantages of compressed air over steam for the operation of mine pumps are: Absence of condensation and radiation losses in pipe lines; high efficiency of compressed-air transmission; ease of disposal of exhaust; absence of danger from broken pipes. The disadvantage is that, at a given initial pressure without reheating, a cylinder full of air develops less power than steam. The power end of the pump should be designed for the use of air, with low clearances and with proper proportions of air and water ends, with regard to the head under which the pump is to operate. Wm. Cox (*Comp. Air Mag.*, Feb., 1899) states the relations of simple or single-cylinder pumps to be  $A/W = 1/2 h/p$ , where  $A$  = area of air cylinder, sq. in.,  $W$  = area of water cylinder, sq. in.,  $h$  = head, ft., and  $p$  = air pressure, lb. per sq. in. Mr. Cox gives the volume  $V$  of free air in cu. ft. per minute to operate a direct-acting, single-cylinder pump, working without cut off, to be

$$V = 0.093 W_2 hG/P.$$

Where  $W_2$  = volume of 1 cu. ft. of free air corresponding to 1 cu. ft. of free air at pressure  $P$ ,  $G$  = gallons of water to be raised per minute,  $P$  =



receiver-gauge pressure of air to be used, and  $h$  = head in feet under which pump works. This formula is based on a piston speed of 100 ft. per minute and 15% has been added to the volume of air to cover losses. The useful work done in a pump using air at full pressure is greater at low pressures than at high, and the efficiency is increased. High pressures are not so economical for simple pumps as low pressures. As high-pressure air is required for drills, etc., and as the air for pumps is drawn from the same main, the air must either be wire-drawn into the pumps, or a reducing valve be inserted between the pump and main. Wire-drawing causes a low efficiency in the pump. If a reducing valve is used, the increase of volume will be accompanied with a drop in temperature, so that the full value of the increase is not realized. Part of the lost heat may be regained by friction, and from external sources. The efficiency of the system may be increased by the use of underground receivers for the expanded air before it passes to the pump. If the receiver be of ample size, the air will regain nearly its normal temperature, the entrained moisture will be deposited and freezing troubles avoided. By compounding the pumps, the efficiency may be increased to about 25 per cent. In simple pumps it ranges from 7 to 16 per cent. For much further information on this subject see Peele's "Compressed-Air Plant for Mines," 1908.

### FANS AND BLOWERS.

**Centrifugal Fans.**—The ordinary centrifugal fan consists of a number of blades fixed to arms revolving at high speed. The width of the blade is parallel to the shaft. The experiments of W. Buckle (*Proc. Inst. M. E.*, 1847) are often quoted as still standard. Mr. Buckle's conclusions, however, do not agree with those of modern experimenters, nor do the proportions of fans as determined by him have any similarity to those of modern fans. The experiments were made on fans of the "paddle-wheel" type, and have no bearing on the more modern multiblade fans of the "Sirocco" type.

The rules laid down by Buckle do not give a fan the highest volumetric efficiency without loss of mechanical efficiency. By volumetric efficiency is meant the ratio of the volume of air delivered per revolution to the cubical contents of the wheel, if the wheel be considered a solid whose dimensions are those of the wheel. Inasmuch as the loss due to friction of the air entering the fan will be less with a large inlet than with a small one, in a wheel of given diameter, more power will be consumed in delivering a given volume of air with a small inlet than with a larger one.

In the ordinary fan the number of blades varies from 4 to 8, while with multiblade fans it is from 48 to 64. The number of blades has a direct relation to the size of the inlet. This is made as large as possible for the reason given above. Any increase in the diameter of the inlet necessarily decreases the depth of the blade, thus diminishing the capacity and pressure. To overcome this decrease, the number of blades is increased to the limit placed by constructional considerations. A properly proportioned fan is one in which a balance is obtained between these two features of maximum inlet and maximum number of blades.

In some cases two fans mounted on one shaft may be more useful than a single wide one, as in such an arrangement twice the area of inlet opening is obtained, as compared with a single wide fan. Such an arrangement may be adopted where occasionally half the full quantity of air is required, as one of the fans may be put out of gear and thus save power.

**Rules for Fan Design.**—It is impossible to give any general rules or formulæ covering the proportions of parts of fans and blowers. There are no less than 14 variables involved in the construction and operation of fans, a slight change in any one producing wide variations in the performance. The design of a new fan by manufacturers is largely a matter of trial and error, based on experiments, until a compromise with all the variables is obtained which most nearly conforms to the given conditions.

**Pressure Due to Velocity of the Fan Blades.**—The pressure of the air due to the velocity of the fan blades may be determined by the formula

$H = \frac{v^2}{2g}$ , deduced from the law of falling bodies, in which  $H$  is the "head" or height of a homogeneous column of air one inch square whose weight is

equal to the pressure per square inch of the air leaving the fan,  $v$  is the velocity of the air leaving the fan in feet per second, and  $g$  the acceleration due to gravity. The pressure of the air is increased by increasing the number of revolutions per minute of the fan. Wolff, in his "The Wind-mill as a Prime Mover," p. 17, argues that it is an error to take  $H = v^2 \div 2g$ , the formula according to him being  $H = v^2 \div g$ . See also Trowbridge (*Trans. A. S. M. E.*, vii., 536). This law is analogous to that of the pressure of a fluid jet striking a plane surface perpendicularly and escaping at right angles to its original path, this pressure being twice that due the height calculated from the formula  $h = v^2 \div 2g$ . (See Hawksley, *Proc. Inst. M. E.*, 1882.) Buckle says: "From the experiments it appears that the velocity of the tips of the fan is equal to nine-tenths of the velocity a body would acquire in falling the height of a homogeneous column of air equivalent to the density."

To convert the head  $H$  expressed in feet to pressure in lb. per sq. in. multiply it by the weight of a cubic foot of air at the pressure and temperature of the air expelled from the fan (about 0.08 lb. usually) and divide by 144. Multiply this by 16 to obtain pressure in ounces per sq. in. or by 2.035 to obtain inches of mercury, or by 27.71 to obtain pressure in inches of water column. Taking 0.08 as the weight of 1 cu. ft. of air, and  $v = 0.9 \sqrt{2gH}$ ,

$p$ lb. per sq. in.	$= 0.00001066 v^2$ ; $v = 310 \sqrt{p}$ nearly;
$p_1$ ounces per sq. in.	$= 0.0001706 v^2$ ; $v = 80 \sqrt{p_1}$ "
$p_2$ inches of mercury	$= 0.00002169 v^2$ ; $v = 220 \sqrt{p_2}$ "
$p_3$ inches of water	$= 0.0002954 v^2$ ; $v = 60 \sqrt{p_3}$ "

in which  $v$  = velocity of tips of blades in feet per second.

Testing the above formula by one of Buckle's experiments with a vane 14 inches long, we have  $p = 0.00001066 v^2 = 9.56$  oz. The experiment gave 9.4 oz.

Taking the formula  $v = 80 \sqrt{p_1}$ , we have for different pressures in ounces per square inch the following velocities of the tips of the blades in feet per second:

$p_1$ = ounces per square inch	2	3	4	5	6	7	8	10	12	14
$v$ = feet per second. . . .	113	139	160	179	196	212	226	253	277	299

Commenting on the statements and formulæ given above, the B. F. Sturtevant Co., in a letter to the author, says: "Let us assume that the fan considered is of the centrifugal type, which is a wheel in a spiral casing. In any case of centrifugal fan the pressure at the

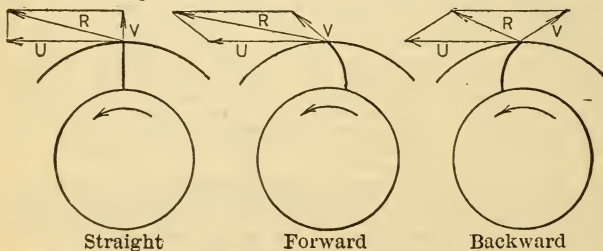

FIG. 146. TYPES OF FAN BLOWERS.

fan outlet is wholly dependent upon the load on the fan, and, therefore, the pressure cannot well be expressed by a formula, unless it includes some term which is an expression in some way of the load upon the fan. The actual pressure depends upon the design of both wheel and housing, upon the blade area and also upon the form of the blades. With a curved blade running with the concave side forward it is possible to obtain a much higher pressure than if the blade is running with the convex side forward. This can only be shown by tests, and can be figured out by blade-velocity diagrams."

It should be noted, however, that while the fan with a blade concaved in the direction of rotation has the highest efficiency, all other

things being equal, the noise of operation is increased. A blade convex in the direction of rotation runs more quietly, and in most situations it is necessary to sacrifice efficiency in order to obtain quiet operation.

Fig. 146 shows the relation of the velocity of air leaving a fan to the velocity of the tips of the blades for radial, bent forward, and bent backward blades.  $V$  represents the direction and amount of the velocity relative to the blade as the air leaves the blade,  $U$  the tangential velocity of the tip of the blade, and  $R$  the component of  $U$  and  $V$ , the velocity of the air relative to the fan casing.

The kinetic energy of the air due to its velocity as it leaves the blades is partially converted into pressure energy as the velocity is reduced in the expanding scroll casing of the fan, and in the diverging outlet of the fan if such an outlet is used. The total or dynamic pressure is the sum of the static pressure and the velocity pressure.

#### QUANTITY OF AIR OF A GIVEN DENSITY DELIVERED BY A FAN.

Total area of nozzles in square feet  $\times$  velocity in feet per minute corresponding to density (see table) = air delivered in cubic feet per minute, discharging freely into the atmosphere (approximate). See p. 670.

Density, ounces per sq. in.	Velocity, feet per minute.	Density, ounces per sq. in.	Velocity, feet per minute.	Density, ounces per sq. in.	Velocity, feet per minute.
1	5,000	5	11,000	9	15,000
2	7,000	6	12,250	10	15,800
3	8,600	7	13,200	11	16,500
4	10,000	8	14,150	12	17,300

**"Blast Area," or "Capacity Area."** When the fan outlet is small the velocity of the outflow is equal to the peripheral velocity of the fan.

Start with the outlet closed; then if the opening be slowly increased while the speed of the fan remains constant the air will continue to flow with the same velocity as the fan tips until a certain size of outlet is reached. If the outlet is still further increased the pressure within the casing will drop, and the velocity of outflow will become less than the tip velocity. The size of the outlet at which this change takes place is called the *blast area*, or *capacity area*, of the fan. This varies somewhat with different types and makes of fans, but for the common form of blower it is approximately,  $DW \div 3$ , in which  $D$  is the diameter of the fan wheel and  $W$  its width at the circumference. — (C. L. Hubbard.)

This established capacity area has no relation to the area of the outlet in the casing, which may be of any size, but is usually about twice the capacity area. The velocity of the air discharged through this latter area is practically that of the circumference of the wheel, and the pressure created is that corresponding thereto. — W. B. Snow.

**Pressure Characteristics of Fans.**—Figs. 147 and 148 show the relation of the static and total pressures, the efficiency and the horse-power, to the capacity of two fans, one a radial blade fan, and the other a multi-blade (conoidal) as determined by tests by the Buffalo Forge Co. In the test the fan was run at a uniform speed and the capacity was varied by varying the area of outlet. The characteristics of the two fans differ greatly. In the case of the radial fan the highest pressure corresponds to zero capacity, while with the multi-blade fan the static pressure increases as the capacity increases up to 100 per cent, or rated capacity, which is the point of maximum efficiency.

If a forward-curved blade fan is intended to operate at a certain pressure and capacity, and if for any reason, such as resistance greater than expected, the quantity of air handled is less than the fan's rating for the speed maintained, the total pressure will also be less than that specified. With the straight-blade fan the opposite holds true, for as the capacity is reduced the pressure will increase, at constant speed.

Care should be taken in the selection of a fan with forward-curved blades in case it is to be driven by a motor. If for any reason there



should be a tendency to operate above rated capacity, both the air quantity and the pressure will increase, which may overload the motor in case sufficient margin of motor capacity has not been provided. (Buffalo Forge Co.)

For a given fan area of outlet, piping system, and air density, the

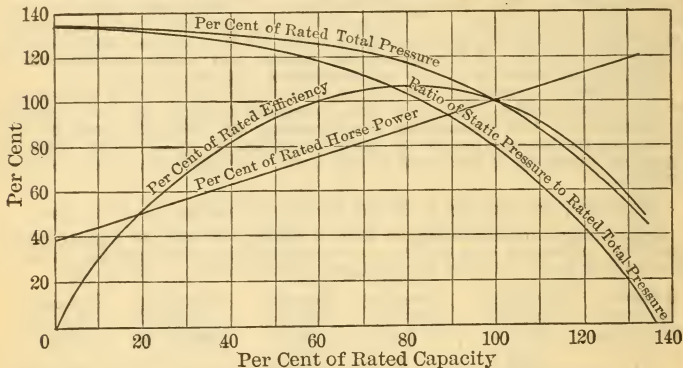

FIG. 147. CHARACTERISTICS OF A RADIAL BLADE FAN.

relations of volume delivered, pressure at the fan outlet, speed and horse-power theoretically vary as follows:

Volume delivered varies directly as speed of the fan.

Pressure varies as the square of the speed.

Horse-power varies as the cube of the speed.

For a given volume the horse-power varies as the square of the speed, showing the great advantage of large fans at slow speeds over

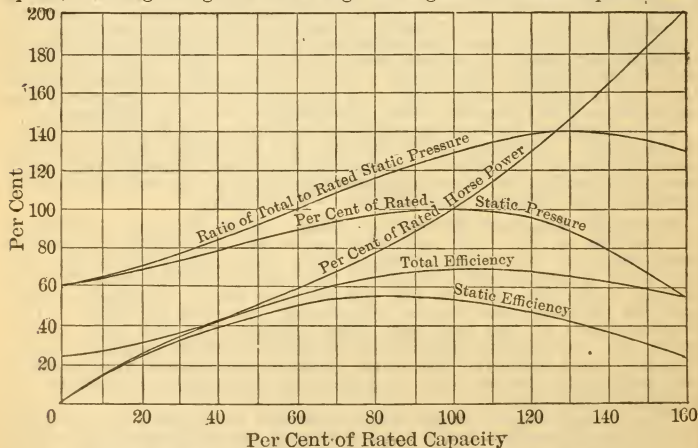

FIG. 148. CHARACTERISTICS OF A MULTI-BLADE FAN.

small fans at high speeds delivering the same volume, the type of fan being the same. The theoretical values are greatly modified by variations in practical conditions. For every fan running at constant speed there is a pressure and corresponding volume at which a fan will operate at its maximum efficiency (see characteristic curves), and a

wide variation in these conditions will give a great drop in efficiency. In selecting a fan for any purpose the catalogues and bulletins issued by manufacturers should be examined, and a tabular comparison made of the sizes, speed, etc., of different fans which may be used for the given purpose and conditions. The following is an example of such a comparison of three multi-blade fans (Sturtevant) which may be used to deliver approximately 15,000 cu. ft. of air against a resistance of 5 in. of water column.

Fan.	Wheel Diam. Inches.	Resistance, 5 in.			Size.	R.P.M.	H.P.
		Vol.	R.P.M.	H.P.			
Turbovane..	22 1/2	15,500	2210	25	Smallest	Highest	Medium
Supervane..	25	15,400	1033	23.5	Medium	Lowest	Lowest
Multivane..	26	15,900	1103	26	Largest	Medium	Highest

**Experiments on a Fan with Constant Discharge-opening and Varying Speed.**—The first four columns are given by Mr. Snell, the others are calculated by the author.

Revs. per min.	Pressure in ounces, $p$	Vol. of Air in cu. ft. per minute, $V$ .	Horse-power.	Velocity of Tips of Blades, ft. per sec.	Velocity due Pressure From Formula $v = 80 \sqrt{p}$ .	Coefficient of formula $v = x \sqrt{p}$ from Experiment.	Velocity of Air per minute in Efflux Pipe, $V \div 0.368$ .	Theoretical Horse-power.	Efficiency per cent.
600	0.50	1336	0.25	60.2	56.6	85.1	3,630	0.182	73
800	0.88	1787	0.70	80.3	75.0	85.6	4,856	0.429	61
1000	1.38	2245	1.35	100.4	94	85.4	6,100	0.845	63
1200	2.00	2712	2.20	120.4	113	85.1	7,370	1.479	67
1400	2.75	3177	3.45	140.5	133	84.8	8,633	2.283	66
1600	3.80	3670	5.10	160.6	156	82.4	9,973	3.803	74
1800	4.80	4172	8.00	180.6	175	82.4	11,337	5.462	68
2000	5.95	4674	11.40	200.7	195	85.6	12,701	7.586	67

Mr. Snell has not found any practical difference between the mechanical efficiencies of blowers with curved blades and those with straight radial ones. From these experiments, says Mr. Snell, it appears that we may expect to receive back 65% to 75% of the power expended, and no more. The great amount of power often used to run a fan is not due to the fan itself, but to the method of selecting, erecting, and piping it. (For opinions on the relative merits of fans and positive rotary blowers, see discussion of Mr. Snell's paper, *Trans. A. S. M. E.*, ix, 66, etc.)

**Comparative Efficiency of Fans and Positive Blowers.** (H. M. Howe, *Trans. A. I. M. E.*, x, 482.) — Experiments with fans and positive (Baker) blowers working at moderately low pressures, under 20 ounces, show that they work more efficiently at a given pressure when delivering large volumes (*i.e.*, when working nearly up to their maximum capacity) than when delivering comparatively small volumes. Therefore, when great variations in the quantity and pressure of blast required are liable to arise, the highest efficiency would be obtained by having a number of blowers, always driving them up to their full capacity, and regulating the amount of blast by altering the number of blowers at work, instead of having one or two very large blowers and regulating the amount of blast by the speed of the blowers.

There appears to be little difference between the efficiency of fans and of Baker blowers when each works under favorable conditions as regards quantity of work, and when each is in good order.

For a given speed of fan, any diminution in the size of the blast-orifice decreases the consumption of power and at the same time raises the pres-

sure of the blast; but it increases the consumption of power per unit of orifice for a given pressure of blast. When the orifice has been reduced to the normal size for any given fan, further diminishing it causes but slight elevation of the blast pressure; and, when the orifice becomes comparatively small, further diminishing it causes no sensible elevation of the blast pressure, which remains practically constant, even when the orifice is entirely closed.

Many of the failures of fans have been due to too low speed, to too small pulleys, to improper fastening of belts, or to the belts being too nearly vertical in brief, to bad mechanical arrangement, rather than to inherent defects in the principles of the machine.

If several fans are used, it is probably essential to high efficiency to provide a separate blast pipe for each (at least if the fans are of different size or speed), while any number of positive blowers may deliver into the same pipe without lowering their efficiency.

**The Sturtevant Multi-blade Fans.**—The B. F. Sturtevant Co. has developed three styles of fans with numerous blades which have been given the trade names Multivane, Supervane, and Turbovane. The Multivane and Supervane fans are used for the same kind of service, that is, mostly for heating, ventilating, and mechanical draught. For a given diameter, the Supervane operates at lower speed and requires less power than the Multivane. The Turbovane fan is designed for high-speed direct-connected drives, such as steam turbines. It is a very wide fan, made double inlet, and for a given volume and pressure will be smaller in diameter and operate at about twice the speed of the Multivane and require about the same power. The Turbovane and Supervane fans have blades considerably deeper than the Multivane. The curvature is also radically different in all three types. The spiral or housing is considerably different in the three types.

### Sturtevant Multivane Fan.

Size.	Height of Casing, Inches.	Resistance 1/2 in.			Resistance 2 in.			Resistance 5 in.			Wheel Diam., Inches.
		Vol., cu. ft. per min.	R.P.M.	H.P.	Vol., cu. ft. per min.	R.P.M.	H.P.	Vol., cu. ft. per min.	R.P.M.	H.P.	
2	21	1,300	705	0.220	2,850	1471	2.15	3,980	2205	6.6	13
3	26 1/2	2,030	565	0.345	4,440	1178	3.3	6,210	1764	10.0	16 1/2
4	31 1/2	2,920	470	0.495	6,400	980	4.8	8,940	1471	14.5	19 1/2
5	37	3,980	404	0.67	8,720	840	6.5	12,200	1260	20	23
6	42	5,200	353	0.88	11,400	735	8.5	15,900	1103	26	26
6 1/2	47	6,570	314	1.10	14,400	654	11.0	20,100	980	33	29 1/2
7	52 1/2	8,110	282	1.40	17,800	588	13.5	24,800	882	41	32 1/2
8	63	11,700	235	2.00	25,600	490	19	35,800	735	60	39
9	73 1/2	15,900	202	2.70	34,800	420	26	48,700	631	80	45 1/2
10	83 1/2	20,800	176	3.50	45,500	368	34	63,600	552	105	52
11	94	26,300	157	4.45	57,600	327	43	80,500	490	135	58 1/2
12	104 1/2	32,500	141	5.5	71,000	294	54	99,400	441	165	65
13	115	39,400	128	6.7	86,100	268	64	121,000	401	200	71 1/2
14	125 1/2	46,800	118	7.9	102,000	245	76	143,000	368	235	78
15	136	54,800	109	9.3	120,000	226	90	168,000	340	275	84 1/2
16	146 1/2	63,500	101	11.0	139,000	210	105	195,000	315	320	91
17	157	73,000	94	12.5	160,000	196	120	224,000	294	370	97 1/2
18	167	83,100	88	14	182,000	184	135	255,000	276	420	104
20	188	105,000	78	18	230,000	163	170	322,000	245	530	117
22	209	130,000	71	22	285,000	147	215	398,000	221	655	130
24	230	157,000	64	27	344,000	134	260	481,000	200	795	143
26	250 1/2	187,000	55	32	410,000	115	305	573,000	173	945	156



Sturtevant Supervane Fan.

Size.	Height of Casing, Inches.	Resistance 1/2 in.			Resistance 2 in.			Resistance 5 in.			Wheel Diam., Inches.
		Vol., cu. ft. per min.	R.P.M.	H.P.	Vol., cu. ft. per min.	R.P.M.	H.P.	Vol., cu. ft. per min.	R.P.M.	H.P.	
A	26	1,470	645	0.235	2,940	1290	1.90	4,160	1980	6.4	13
B	32	2,230	525	0.355	4,460	1051	2.90	6,320	1610	9.7	16
C	38	3,150	442	0.50	6,300	885	4.05	8,910	1358	13.5	19
D	44	4,200	382	0.67	8,420	764	5.4	11,900	1171	18.0	22
E	49 1/2	5,450	337	0.87	10,900	673	7.0	15,400	1033	23.5	25
F	55 1/2	6,820	300	1.10	13,600	600	8.8	19,300	921	30	28
G	63 1/2	8,900	262	1.40	17,800	525	11.5	25,200	805	38	32
H	73 1/2	11,300	233	1.80	22,600	467	14.5	32,000	716	49	36
J	79 1/2	13,900	210	2.20	27,800	420	18	39,400	645	60	40
K	91 1/2	18,500	183	2.90	36,900	365	24	52,300	560	80	46
L	103	23,500	162	3.75	47,000	323	30	66,600	496	100	52
M	115	29,300	145	4.65	58,500	290	38	83,000	444	125	58
N	127	35,600	131	5.7	71,200	263	46	101,000	403	155	64
P	139	42,700	120	6.8	85,400	240	56	121,000	368	185	70
Q	150 1/2	50,300	111	8.0	101,000	221	66	143,000	339	220	76
R	166 1/2	61,400	100	9.8	123,000	200	80	174,000	307	265	84
S	182 1/2	73,500	91	11.5	147,000	183	96	208,000	280	320	92
T	198 1/2	86,900	84	14.0	174,000	168	110	246,000	258	375	100
U	214 1/2	102,000	78	16.0	204,000	156	130	288,000	239	440	108
V	230	117,000	72	18.5	234,000	145	150	332,000	222	505	116
W	254	143,000	66	23	285,000	131	185	404,000	202	615	128
X	277 1/2	171,000	60	27	341,000	120	220	483,000	184	740	140
Y	301 1/2	201,000	55	32	401,000	111	260	569,000	170	870	152

Sturtevant Turbovane Fan.

Size.	Height of Casing, Inches.	Resistance 1 in.			Resistance 3 in.			Resistance 6 in.			Wheel Diam., Inches.
		Vol., cu. ft. per min.	R.P.M.	H.P.	Vol., cu. ft. per min.	R.P.M.	H.P.	Vol., cu. ft. per min.	R.P.M.	H.P.	
40	28	1,670	1958	0.53	2,930	3400	2.85	4,010	4760	7.8	11 1/2
45	35	2,610	1563	0.83	4,560	2720	4.4	6,250	3800	12.0	14 1/2
50	42	3,770	1300	1.20	6,600	2260	6.5	9,050	3161	17.5	17
55	49	5,100	1118	1.65	8,950	1940	8.8	12,300	2719	23.5	20
60	56	6,700	978	2.15	11,700	1700	11.0	16,100	2380	31	22 1/2
65	63	8,500	868	2.75	14,900	1510	14.5	20,400	2115	39	25 1/2
70	70	10,500	781	3.35	18,300	1358	17.5	25,100	1900	48	28 1/2
80	84	15,100	651	4.85	26,300	1131	26	36,100	1582	70	34
90	97	20,500	558	6.5	35,800	971	35	49,100	1360	92	39 1/2
100	112	26,800	490	8.5	46,800	851	45	64,000	1192	120	45
110	126	34,000	435	11.0	59,500	755	58	81,500	1058	155	51
120	140	41,800	391	13.5	73,000	679	70	101,000	950	190	56 1/2
130	154	50,500	353	16.5	88,500	617	86	122,000	865	230	62
140	168	60,500	326	19.5	106,000	566	100	145,000	792	280	67 1/2
150	182	71,000	300	22.5	124,000	521	120	170,000	729	325	73 1/2
160	196	82,000	279	26	144,000	485	140	197,000	680	380	79

**Capacity of Fans and Blowers.**—The following tables supplied (1909) by the American Blower Co., Detroit, show the capacities of exhaust fans and volume and pressure blowers. The tables are all based on curves established by experiment. The pressures, volumes and horse-powers were all actually measured with the apparatus working against maintained resistances formed by restrictions equivalent to those found in actual practice, and which experience shows will produce the best results.

### Speed, Capacity and Horse-power of Steel Plate Exhaust Fans.

(American Blower Co., Type E, 1908.)

No. of fan.	Diameter of wheel, in.	Width periphery, in.	Diameter inlet (inside), in.	1/2 oz. pressure.			3/4 oz. pressure.			1 oz. pressure.			2 oz. pressure.		
				R.P.M.	Cubic ft. per minute.	Brake horse-power.	R.P.M.	Cubic ft. per minute.	Brake horse-power.	R.P.M.	Cubic ft. per minute.	Brake horse-power.	R.P.M.	Cubic ft. per minute.	Brake horse-power.
25	16	6 1/8	10	985	1,09	0.30	1200	1,345	0.56	1390	1,555	0.85	1966	2,200	2.40
30	19	7 1/8	12	830	1,580	0.43	1012	1,940	0.80	1170	2,240	1.22	1655	3,175	3.46
35	22	8 1/8	14	715	2,155	0.59	876	2,635	1.08	1010	3,040	1.66	1430	4,310	4.70
40	25	9 3/8	16	630	2,820	0.77	772	3,450	1.41	890	3,980	2.17	1260	5,640	6.15
45	28	10 7/8	18	563	3,560	0.97	689	4,360	1.78	795	5,030	2.74	1125	7,140	7.79
50	31	12 3/8	20	508	4,400	1.20	622	5,390	2.20	719	6,220	3.39	1015	8,820	9.63
55	34	13 1/2	22	464	5,330	1.45	567	6,525	2.66	655	7,530	4.10	927	10,650	11.60
60	38	14 1/2	24	415	6,350	1.73	509	7,775	3.18	587	8,960	4.89	830	12,700	13.85
70	44	15 1/8	27	375	7,440	2.02	459	9,120	3.72	530	10,500	5.72	750	14,875	16.20
80	50	16 1/2	29	328	10,050	2.75	402	12,100	4.94	464	13,980	7.62	656	19,800	21.60

### Speed, Capacity and Horse-power of Volume Blowers.

(American Blower Co., Type V, 1909.)

No. of fan.	Diameter of wheel, in.	Width periphery, in.	Diameter inlet (inside), in.	1/2 oz. pressure.			3/4 oz. pressure.			1 oz. pressure.			1 1/2 oz. pressure.		
				R.P.M.	Cubic ft. per minute.	Brake horse-power.	R.P.M.	Cubic ft. per minute.	Brake horse-power.	R.P.M.	Cubic ft. per minute.	Brake horse-power.	R.P.M.	Cubic ft. per minute.	Brake horse-power.
1	8 1/2	2	4 1/2	1850	223	0.06	2270	273	0.11	2620	315	0.17	3210	386	0.32
2	10 1/4	2 3/8	5 1/2	1535	332	0.09	1880	407	0.17	2170	469	0.26	2660	576	0.48
3	12	3 1/4	6 1/2	1310	464	0.13	1600	569	0.23	1850	656	0.36	2275	805	0.66
4	15 1/2	4 3/2	8 1/2	1015	795	0.22	1240	975	0.40	1435	1122	0.61	1760	1377	1.13
5	19	5 1/8	10 3/8	830	1185	0.32	1013	1450	0.59	1170	1675	0.92	1435	2055	1.68
6	22 1/2	6 1/2	12 3/8	700	1686	0.46	858	2065	0.84	990	2385	1.30	1215	2930	2.40
7	26	7 1/2	14 1/4	606	2235	0.61	742	2740	1.12	858	3160	1.72	1050	3880	3.18
8	29 1/2	8 1/2	16 1/4	534	2910	0.79	654	3560	1.45	755	4110	2.24	928	5040	4.13
9	33	9 1/2	18 1/4	477	3660	1.00	585	4490	1.83	675	5175	2.82	825	6350	5.20

NOTE: This table also applies to Type V, cast-iron exhaust fans.

Steel Pressure Blowers for Cupolas (Average Application).

(American Blower Co., 1909.)

No. of blower.	Dia. of wheel. in.	Width periph'y. in.	Circum. of wheel, ft.	Dia. outlet pipes, in.	Area of outlet, sq. ft.	Oz.	2	3	4	5	6	7	8	9
						In.	3.46	5.19	6.92	8.65	10.38	12.12	13.83	15.56
						H.P. const. at 1000 cu. ft.	1.242	1.86	2.48	3.10	3.73	4.35	4.95	5.58
1	14 1/2	13/8	3.80	5 3/4	0.18	R.P.M.	1960	2400	2770	3095	3390	3666	3915	4150
						C.F.	361	434	500	560	610	665	708	752
						H.P.	0.45	0.81	1.24	1.74	2.28	2.89	3.51	4.20
2	17	15/8	4.45	6 3/4	0.2485	R.P.M.	1675	2050	2362	2645	2895	3130	3340	3540
						C.F.	498	600	691	774	843	916	978	1038
						H.P.	0.62	1.12	1.72	2.40	3.15	3.99	4.84	5.79
3	19 1/2	17/8	5.11	7 3/4	0.327	R.P.M.	1460	1785	2060	2300	2520	2730	2910	3085
						C.F.	655	789	910	1018	1110	1207	1286	1365
						H.P.	0.82	1.47	2.26	3.16	4.15	5.25	6.36	7.62
4	22	21/8	5.76	8 3/4	0.4176	R.P.M.	1292	1582	1825	2040	2235	2420	2585	2740
						C.F.	838	1006	1162	1300	1415	1540	1643	1746
						H.P.	1.04	1.87	2.88	4.03	5.28	6.70	8.14	9.74
5	24 1/2	23/8	6.41	9 3/4	0.519	R.P.M.	1162	1422	1640	1835	2010	2175	2320	2460
						C.F.	1040	1250	1442	1612	1760	1915	2040	2166
						H.P.	1.30	2.33	3.58	5.00	6.57	8.34	10.10	12.10
6	27	27/8	7.06	10 3/4	0.63	R.P.M.	1055	1290	1490	1665	1825	1975	2105	2233
						C.F.	1262	1520	1750	1960	2135	2375	2475	2630
						H.P.	1.57	2.83	4.34	6.08	7.96	10.10	12.25	14.12
7	32	33/8	8.39	12 1/2	0.852	R.P.M.	889	1087	1255	1405	1535	1660	1775	1880
						C.F.	1705	2055	2366	2650	2890	3140	3350	3555
						H.P.	2.12	3.83	5.86	8.23	10.78	13.66	16.60	19.83
8	37	37/8	9.70	14	1.069	R.P.M.	769	940	1085	1212	1328	1446	1533	1625
						C.F.	2140	2575	2970	3325	3620	3940	4200	4460
						H.P.	2.66	4.79	7.36	10.3	13.5	17.15	20.80	24.90
9	42	43/8	10.98	16	1.396	R.P.M.	679	830	958	1072	1172	1270	1355	1435
						C.F.	2800	3370	3880	4340	4730	5150	5500	5825
						H.P.	3.48	6.27	9.63	13.46	17.65	22.40	27.25	32.50
10	47	47/8	12.30	17 1/2	1.67	R.P.M.	606	742	855	956	1048	1133	1210	1280
						C.F.	3350	4025	4640	5200	5660	6160	6570	6970
						H.P.	4.17	7.5	11.5	16.12	21.12	26.80	32.55	38.90
11	52	53/8	13.6	19 1/4	2.02	R.P.M.	548	670	774	865	947	1025	1093	1160
						C.F.	4050	4870	5610	6290	6850	7450	7950	8440
						H.P.	5.03	9.06	13.9	19.5	25.55	32.40	39.33	47.10
12	57	57/8	14.92	21	2.405	R.P.M.	500	611	705	789	863	934	996	1056
						C.F.	4820	5800	6700	7490	8160	8870	9460	10040
						H.P.	6.00	10.78	16.62	23.25	30.45	38.60	46.85	56.10



Steel Pressure Blowers for Cupolas (Average Application).—  
Continued.

No. of blower.	Dia. of wheel, in.	Width, per y. in.	Circum. of wheel, ft.	Dia. outlet pipes, in.	Area of outlet, sq. ft.	Oz.	10	11	12	13	14	15	16
						In.	17.28	19.02	20.75	22.5	24.22	25.95	27.66
						H.P. const. at 1000 cu. ft.	6.20	6.82	7.44	8.07	8.69	9.30	9.92
2	17	15/8	4.45	63/4	0.2485	R.P.M.	3740	3920	4090	.....	.....	.....	.....
						C.F.	1093	1148	1196	.....	.....	.....	.....
						H.P.	6.78	7.83	8.9	.....	.....	.....	.....
3	19 1/2	17/8	5.11	73/4	0.327	R.P.M.	3255	3415	3570	3710	3955	3985	4120
						C.F.	1440	1510	1575	1642	1700	1762	1820
						H.P.	8.93	10.3	11.72	13.26	14.75	16.4	18.05
4	22	21/8	5.76	83/4	0.4176	R.P.M.	2890	3030	3163	3290	3420	3535	3650
						C.F.	1840	1930	2012	2095	2175	2250	2325
						H.P.	11.40	13.16	14.96	16.9	18.9	20.9	23.1
5	24 1/2	23/8	6.41	93/4	0.519	R.P.M.	2595	2720	2845	2960	3075	3180	3280
						C.F.	2280	2395	2500	2605	2700	2800	2885
						H.P.	14.13	16.33	18.6	21.05	23.45	26.05	28.66
6	27	27/8	7.06	103/4	0.63	R.P.M.	2355	2470	2580	2685	2790	2885	2980
						C.F.	2770	2910	3033	3165	3280	3395	3500
						H.P.	17.18	19.85	22.6	25.55	28.50	31.55	34.7
7	32	33/8	8.39	121/2	0.852	R.P.M.	1983	2080	2170	2260	2345	2430	2510
						C.F.	3750	3930	4110	4276	4430	4590	4730
						H.P.	23.25	26.80	30.6	34.5	38.5	42.7	47.
8	37	37/8	9.70	14	1.069	R.P.M.	1715	1800	1880	1955	2030	2100	2170
						C.F.	4700	4930	5150	5360	5560	5760	5940
						H.P.	29.15	33.66	38.33	43.25	48.30	53.55	59.
9	42	43/8	10.98	16	1.396	R.P.M.	1515	1590	1660	1728	1792	1855	1916
						C.F.	6150	6450	6730	7010	7270	7525	7760
						H.P.	38.15	44.00	50.15	56.60	63.2	70.	77.
10	47	47/8	12.30	171/2	1.67	R.P.M.	1352	1418	1480	1540	1600	1655	1710
						C.F.	7350	7715	8055	8390	8700	9010	9300
						H.P.	45.60	52.66	60.	67.66	75.6	83.9	92.25
11	52	53/8	13.6	191/4	2.02	R.P.M.	1222	1282	1340	1393	1447	1498	1546
						C.F.	8900	9330	9750	10140	10520	10890	11220
						H.P.	55.20	63.6	72.5	82.	91.5	101.2	111.33
12	57	57/8	14.92	21	2.405	R.P.M.	1113	1168	1220	1270	1318	1363	1410
						C.F.	10580	11100	11600	12080	12520	12960	13380
						H.P.	65.5	75.70	86.33	97.5	10.	120.5	132.75

**Caution in Regard to Use of Fan and Blower Tables.**—Many engineers report that some manufacturers' tables overrate the capacity of their fans and underestimate the horse-power required to drive them. In some cases the complaints may be due to restricted air outlets, long and crooked pipes, slipping of belts, too small engines, etc. It may also be due to the fact that the volumes are stated without being accompanied by information as to the maintained resistance, and the volumes given

may be those delivered with an unrestricted inlet and outlet. As this condition is not a practical one, the volume delivered in an installation is much smaller than that given in the tables. The underestimating of horse-power required may be due to the fact that the volumes given in tables are for operation against a practical resistance, and in an installation it might be that the resistance was low, consequently the volume and also the horse-power required would be greater.

**Capacity of Sturtevant High-Pressure Blowers (1908).**

Number of blower.	Capacity in cubic feet per minute, 1/2 lb. pressure.	Revolutions per minute.	Inside dia. of inlet and outlet, inches.	Approx. weight, pounds.*
000	1 to 5	200 to 1000	1 3/8	40
00	5 to 25	375 to 800	1 1/2	80
0	25 to 45	370 to 800	2 1/2	140
1	45 to 130	240 to 600	3	330
2	130 to 225	300 to 500	4	550
3	225 to 325	380 to 525	4	760
4	325 to 560	350 to 565	6	1,080
5	560 to 1,030	300 to 475	8	1,670
6	1,030 to 1,540	290 to 415	10	2,500
7	1,540 to 2,300	280 to 410	10	3,200
8	2,300 to 3,300	265 to 375	12	4,700
9	3,300 to 4,700	250 to 350	16	6,100
10	4,700 to 6,000	260 to 330	16	8,000
11	6,000 to 8,500	220 to 310	20	12,100
12	8,500 to 11,300	190 to 250	24	18,700
13	11,300 to 15,500	190 to 260	30	22,700

\* Of blower for 1/2 lb. pressure.

**Performance of a No. 7 Steel Pressure Blower under Varying Conditions of Outlet.**

Per cent of Rated Capacity.....	0	20	40	60	80	100	120	140	160	180	200	220	240
Per cent of Rated H.P.	28	42	57	72	86	100	116	130	144	159	173	187	202
Total pressure, oz. ...	10.2	11.4	11.9	12.0	11.9	11.4	10.9	10.3	9.7	9.1	8.5	7.9	7.2
Static pressure, oz. ..	10.2	11.2	11.6	11.4	11.0	10.2	9.2	8.0	6.6	5.0	3.5	1.9	0.3
Efficiency, per cent .....	0	26	40	50	56	60	62	61	59	56	52	48	45

The above figures are taken from a plotted curve of the results of a test by the Buffalo Forge Co. in 1905. A letter describing the test says :

The object was to determine the variation of pressure, power and efficiency obtained at a constant speed with capacities varying from zero discharge to free delivery. A series of capacity conditions were secured by restricting the outlet of the blower by a series of converging cones, so arranged as to make the convergence in each case very slight, and of sufficient length to avoid any noticeable inequality in velocities at the discharge orifice. The fan was operated as nearly at constant speed as possible. The velocity of the air at the point of discharge was measured by a Pitot tube and draft gauge of usual construction. Readings were taken over several points of the outlet and the average taken, although

the variation under nearly all conditions was scarcely perceptible. A coefficient of 93% was assumed for the discharge orifice. The pressure was taken as the reading given by the Pitot tube and draft gauge at outlet. The agreement of this reading with the static pressure in a chamber from which a nozzle was conducted had been checked by a previous test in which the two readings, *i.e.*, velocity and static pressure, were found to agree exactly within the limit of accuracy of the draft gauge, which was about 0.01 in., or, in this case, within 1%. The horsepower was determined by means of a motor which had been previously calibrated by a series of brake tests. Variations in speed were assumed to produce variation in capacity in proportion to the speed, variation in pressure to the square of the speed, and variation in H.P. in proportion to the cube of the speed. These relations had been previously shown to hold true for fans in other tests. They were also checked up by operating the fan at various speeds and plotting the capacities directly with the speed as abscissa, the pressure with the square of the speed as abscissa, and the horse power with the cube of the speed as abscissa. These were found, as in previous cases, to have a practically straight-line relation, in which the line passed through the origin.

**Effect of Resistance upon the Capacity of a Fan.** — A study of the figures in the above table shows the importance of having ample capacity in the air mains and delivery pipes, and of the absence of sharp bends or other obstructions to the flow which may increase the resistance or pressure against which the fan operates. The fan delivering its rated capacity against a static pressure of 10.2 ounces delivers only 40% of that capacity, with the same number of revolutions, if the pressure is increased to 11.6 ounces; the power is reduced only to 57%, instead of 40%, and the efficiency drops from 60% to 40%.

### Dimensions of Sirocco Fans.

(American Blower Co., 1909.)

Diameter of Wheel, in.	Width at Periphery, in.	No. of Blades.	Total Blade Area, sq. in.	Height of Housing. (Approx.)	Width bet. Sides, in.	Length of Housing.	Max. Area of Inlet, sq. ft.	Min. Area of Inlet, sq. ft.	Area of Square Outlet, sq. ft.	Area of Circular Evasé Outlet sq. ft.	Length of Evasé Cone.
6	3	48	56	11"	4	10"	.23	.123	.11	.12	3"
9	4 1/2	48	127	1' 4"	8	1' 3"	.49	.349	.25	.35	4 1/4"
12	6	64	226	1' 9"	8	1' 7"	.85	.616	.44	.60	5 3/4"
15	7 1/2	64	353	2' 4"	10	2' 0"	1.46	.957	.69	.92	7 1/4"
18	9	64	509	2' 10"	12	2' 5"	1.87	1.37	1.00	1.40	8 1/2"
21	10 1/2	64	693	3' 4"	14	2' 10"	2.40	1.87	1.34	1.87	10"
24	12	64	904	3' 8"	16	3' 3"	3.14	2.46	1.78	2.40	11 1/2"
27	13 1/2	64	1144	4' 3"	18	3' 7"	4.59	3.11	2.25	3.14	13"
30	15	64	1413	4' 7"	20	4' 0"	5.58	3.83	2.78	3.83	14 1/2"
36	18	64	2036	5' 6"	24	4' 10"	7.87	5.50	4.00	5.58	17"
42	21	64	2770	6' 5"	28	5' 7"	10.56	7.47	5.44	7.47	20"
48	24	64	3617	7' 3"	32	6' 5"	13.6	9.79	7.11	9.85	23"
54	27	64	4578	8' 2"	36	7' 3"	17.0	12.3	9.00	12.3	26"
60	30	64	5652	9' 1"	40	8' 0"	20.9	15.2	11.11	15.3	28 1/2"
66	33	64	6839	9' 11"	44	8' 10"	25.2	18.4	13.41	18.3	31 1/2"
72	36	64	8144	10' 10"	48	9' 7"	29.8	22.2	16.00	22.3	34 1/2"

**Sirocco or Multivane Fans.** — There has recently (1909) come into use a fan of radically different proportions and characteristics from the ordinary centrifugal fan. This fan is composed of a great number of shallow vanes, ranging from 48 to 64, set close together around the periphery of the fan wheel. Over a large range of sizes, 64 vanes appear to give the





best results. The vanes, measured radially, have a depth  $\frac{1}{16}$  the fan diameter. Axially, they are much longer than those of the ordinary fan, being  $\frac{3}{5}$  the fan diameter. The fan occupies about  $\frac{1}{2}$  the space, and is about  $\frac{2}{3}$  the weight of the ordinary fan. The vanes are concaved in the direction of rotation and the outer edge is set forward of the inner edge. The inlet area is of the same diameter as the inner edge of the blades. Usually the inlet is on one side of the fan only, and is unobstructed, the wheel being overhung from a bearing at the opposite end. A peculiarity of this type of fan is that the air leaves it at a velocity about 80 per cent in excess of the peripheral speed of the blades. The velocity of the air through the inlet is practically uniform over the entire inlet area. The power consumption is relatively low. This type of fan was invented by S. C. Davidson of Belfast, Ireland, and is known as the "Sirocco" fan. It is made under that name in this country by the American Blower Co., to which the author is indebted for the preceding tables.

A Test of a "Sirocco" Mine Fan at Llwnypia, Wales, is reported in *Eng'g.*, April 16, 1909. The fan is 11 ft. 8 in. diam., double inlet, direct-coupled to a 3-phase motor. Average of three tests: Revs. per min., 184; peripheral speed, 6,705 ft. per min.; water-gauge in fan drift and in main drift, each 6 in.; area of drift, 184.6 sq. ft.; av. velocity of air, 1842 ft. per min.; volume of air, 340,033 cu. ft. per min.; H.P. input at motor, 420; Brake H.P. on fan shaft, 390; Indicated H.P. in air, 321.5; efficiency of motor, 93%; mechanical efficiency of fan, 82.43%; combined mechanical efficiency of fan and motor, 76.6%.

#### High-Pressure Centrifugal Fans. (See page 648.)

**The Conoidal Fan.**—A multiblade fan in which the blades are not parallel to the shaft, but inclined to it, so that their tips form the shape of a cone, the inlet being the large diameter, is made by the Buffalo Forge Co. It is known as the Buffalo Niagara Conoidal Fan. A table of the regular sizes of these fans is given below.

#### Capacities of Buffalo Niagara Conoidal Fans.

Under Average Working Conditions at 70° F. and 30 in. Barometer. Static Pressure is 77.5% of Total Pressure. Volumes in cu. ft. per min.

Fan No.	Mean Diam. Blast Wheel.	Area of Outlet, Sq. ft.	1-in. Total Pressure, or 0.577 oz.			2-in. Total Pressure, or 1.154 oz.			4-in. Total Pressure, or 2.307 oz.		
			R.P.M.	Vol.	H.P.	R.P.M.	Vol.	H.P.	R.P.M.	Vol.	H.P.
3	15 $\frac{5}{8}$	1.31	675	2,440	0.54	955	3,450	1.54	1350	4,480	4.35
3 $\frac{1}{2}$	18 $\frac{1}{8}$	1.79	579	3,320	0.74	818	4,690	2.09	1157	6,640	5.92
4	20 $\frac{1}{2}$	2.33	506	4,340	0.97	716	6,130	2.73	1013	8,670	7.73
4 $\frac{1}{2}$	23 $\frac{1}{2}$	2.95	450	5,490	1.22	636	7,760	3.46	900	10,970	9.78
5	26 $\frac{1}{8}$	3.64	405	6,770	1.51	573	9,580	4.27	810	13,550	12.1
5 $\frac{1}{2}$	28 $\frac{3}{4}$	4.41	368	8,200	1.83	521	11,590	5.17	736	16,390	14.6
6	31 $\frac{3}{8}$	5.25	338	9,750	2.17	477	13,790	6.15	675	19,510	17.4
7	36 $\frac{1}{2}$	7.14	289	13,280	2.96	409	18,770	8.37	579	26,550	23.7
8	42	9.33	253	17,340	3.87	358	24,520	10.9	506	34,680	30.9
9	47	11.81	225	21,950	4.89	318	31,020	13.8	450	43,890	39.1
10	52	14.58	203	27,090	6.04	286	38,310	17.1	405	54,180	48.3
11	58	17.64	184	32,780	7.31	260	46,360	20.7	368	65,560	58.5
12	63	21.00	169	39,010	8.70	239	55,170	24.6	338	78,020	69.6
13	68	24.65	156	45,780	10.2	220	64,730	28.9	312	91,560	81.6
14	73	28.68	145	53,100	11.8	205	75,090	33.5	289	106,200	94.7
15	78	32.80	135	60,960	13.6	191	86,200	38.4	270	121,920	108.7
16	84	37.32	127	69,360	15.5	179	98,060	43.7	253	138,700	123.7
17	89	42.14	119	78,300	17.5	169	110,720	49.4	238	156,600	139.6
18	94	47.24	113	87,780	19.6	159	124,110	55.3	225	175,550	156.5
19	99	52.63	107	97,800	21.8	151	138,280	61.7	213	195,600	174.4
20	105	58.32	101	108,370	24.2	143	153,250	68.3	202	216,720	193.2

## METHODS OF TESTING FANS.

*Anemometer Method.*—Measurements by anemometers are liable to be very inaccurate (see page 625) and results obtained by them should be considered only as rough approximations.

*Water Gauge Readings at End of Tapered Cone.*—This method is also far from accurate on account of variable eddies in the air column.

*Pitot Tube Readings in Center of Discharge Pipe.*—This method gives fairly accurate results when the discharge pipe is the same size as the fan outlet, when the Pitot tube is placed at a distance equal to at least 15 diameters of the pipe from the fan outlet, when the tube is so made that it will give correct readings of the static pressure, and when the velocities computed from the readings are corrected by a coefficient (0.87 to 0.92 in different experiments) for the ratio between the average velocity and the velocity at the center of the tube.

*Pitot Tube Readings in Zones of Equal Area.*—More accurate results may be obtained if the tube is traversed across two diameters of the tube at right angles to each other, placing the nozzle successively at points which will divide the cross-sectional area into equal annular areas (with one central circular area). If ten such points are taken on each diameter, the radial distances of the points from the center of the pipe will be 31, 55, 71, 84, and 95% of the radius of the pipe from the center. Since the velocity at any point is proportional to the square root of the velocity head, it is necessary for accurate results to take the average of the square root of the readings, and square this average to obtain the mean velocity head of the whole area of the pipe. For low pressures an inclined manometer should be used with the Pitot tube, and it should contain gasoline instead of water, as it keeps the tubes clean, has a definite meniscus and almost no capillary attraction for the glass. The readings of the tube are to be corrected for the inclination and for the specific gravity of the gasoline to reduce them to equivalent inches of water column.

The best form of Pitot tube is one made of two thin brass tubes, the outer one  $\frac{1}{4}$ -in. and the inner one  $\frac{1}{8}$ -in. external diameter, each about 4 or 5 in. long, the two being soldered together at one end and the end then tapered down to a sharp edged nozzle. Each tube is connected near the rear end to tubes at right angles to the double tube, leading to two manometers, one for reading the total, or dynamic or impact pressure, the other the static pressure. The difference between these two readings is the velocity head. It may be obtained in one reading by connecting both parts of the tube to a single manometer. The outer, or static, tube has two or more smooth holes drilled in it, diametrically opposite, at right angles to the axis, to receive the static pressure. The exact form of the nozzle of the impact tube is not of importance, as different forms give identical readings, but care must be taken with the holes of the static tube or errors will be made in the readings due to action of the dynamic pressure on these holes if they are not properly made. A thin slot instead of the holes has been found to give inaccurate readings. (See papers by Chas. S. Treat, *Trans. A. S. M. E.*, vol. 34, and W. C. Rowse, *Jour. A. S. M. E.*, Sept., 1913.)

For accurate scientific work it is well to check the static tube readings by manometer readings from a piezometer ring, which is a narrow annular channel encircling the pipe and soldered to it to make it airtight. Six or more smooth holes are bored into the pipe at right angles to its axis, to connect the interior of the pipe with the ring. The Pitot tube may also be calibrated by means of a Thomas electric gas meter.

*The Thomas Electric Meter* for air and gas consists of an enlargement of section of the flow pipe into a chamber of a diameter equal to about two diameters of the pipe, with conical ends connecting it with the pipe. In the interior is placed an electric heater made of bare resistance wire mounted on a fiber frame and equally distributed over the section of the chamber, and also two electric resistance thermometers, one in front of and the other behind the heater. An electric current, measured by a wattmeter, is passed through the heater and the temperatures before and after the heating are measured by the thermometers. If  $T_1$  and  $T_2$  are the temperatures before and after the heating,  $H$  the heat units corresponding to the watts delivered to the heater ( $1 \text{ watt} =$



3.415 B.T.U. per hour), and  $S$  the specific heat of the air, then the weight of air heated in lb. per min. is  $W = \frac{H}{60S(T_2 - T_1)}$ .

When the Pitot tube is correctly made and used its formula is  $v = \sqrt{2gh}$ , in which  $h$  is the mean velocity head, measured as the height in feet of a column of air which would produce the observed velocity and  $v$  the velocity in ft. per sec.

To convert the velocity head as measured in the Pitot tube in inches of water column into velocity of the air in feet per min. we have the following formulæ:

$p$  = velocity pressure in inches of water gage.  
 $h$  = corresponding head in feet of a column of air.  
 $v$  = velocity of air in ft. per sec.  $V$  = velocity in ft. per min.  
 $w$  = weight of 1 cu. ft. of air under existing conditions.

$$h = \frac{62.3 p}{12 w}; v = \sqrt{\frac{64.32 \times 62.3 p}{12 w}}; v = 18.27 \sqrt{\frac{p}{w}}$$

$$V, \text{ ft. per min.} = 1096.2 \sqrt{\frac{p}{w}}$$

The average weight of 1 cu. ft. of air was found by the American Blower Co. in a large number of tests to be 0.0715 lb. per cu. ft., whence  $V = 4101\sqrt{p}$ .

The velocity of flow of air at a given density produced by a pressure of 1 in. of water is called the "velocity constant" of air at that density. A table of such constants is given by the American Blower Co., from which the following table is condensed:

AIR CONSTANTS FOR DRY AIR AT SEA LEVEL, BAR. 29.92 IN.

Temp. ° F.	K.	Ratio.	Temp. ° F.	K.	Ratio.	Temp. ° F.	K.	Ratio.	Temp. ° F.	K.	Ratio.
-40	3567	0.890	60	3968	0.990	160	4333	1.082	500	5389	1.345
-20	3651	.911	70	4006	1.000	180	4402	1.098	600	5663	1.413
0	3733	.932	80	4044	1.009	200	4470	1.114	700	5925	1.478
10	3773	.942	90	4081	1.018	250	4636	1.157	800	6177	1.542
20	3813	.952	100	4118	1.028	300	4795	1.197	900	6418	1.602
30	3852	.961	110	4155	1.037	350	4890	1.236	1000	6650	1.660
40	3891	.971	120	4191	1.046	400	5101	1.273	1100	6873	1.715
50	3930	.981	140	4263	1.064	450	5246	1.310	1200	7090	1.770

$$\text{Constant } K = \sqrt{\frac{2g \times \text{weight of 1 cu. ft. water at } 62^\circ \text{ F.}}{12 \times \text{weight of 1 cu. ft. air at temp. stated.}}}$$

The values under Ratio give ratios of fan speeds necessary at the various temperatures to produce the same water gage indication.

**Horse-power of a Fan.**—If  $C$  = cu. ft. of air delivered per minute,  $W$  = weight of 1 cu. ft. of air under existing conditions,  $H$  the height in feet of an air column equivalent to the total pressure,  $D$  the dynamic pressure in inches of water column =  $WH \div 5.2$ , the horse-power developed by the delivery of the air is  $A = CWH \div 33,000 = CD \div 6356$ . One inch water gage = 5.2 lb. per sq. ft. The total pressure  $D$  with which the fan should be credited is the difference between the total pressure in the discharge pipe and that in the inlet pipe.

The air horse-power divided by the power required to drive the fan, as measured by a dynamometer, gives the mechanical efficiency of the fan.

From the above formulæ the air horse-power is a function of two variables, volume and pressure. To obtain what is called the "static efficiency," the fan should be credited with the difference between the static pressure in the medium from which the fan is drawing air and the static pressure in the discharge pipe. To obtain the

impact or total efficiency the fan should be credited with the kinetic energy in the air in the discharge pipe or with the difference between the static pressure in the medium from which the fan is drawing air and the total or impact pressure in the discharge pipe.

The work of compression is negligible, as these methods have to do with air under low pressure. When readings are taken on the suction side of the fan, for the purpose of determining static efficiency, the fan should be credited only with the difference between the static pressure in the discharging medium and the impact pressure in the inlet pipe. If the object is to determine the impact efficiency where readings are taken at the suction side of the fan, the pressure with which the fan should be credited is the difference between the impact reading at the fan discharge and the impact reading obtained in the inlet pipe. This total pressure with which the fan is credited may also be expressed as the difference between the static pressure in the discharge pipe and the static suction in the inlet pipe, plus the increase of the velocity pressure in the outlet pipe over the velocity pressure in the inlet pipe.

**Accuracy of Pitot Tube Measurements.**—To obtain even approximately accurate results with Pitot tubes it is necessary both to have the tube properly made and to take great precautions in using it. W. C. Rowse, *Trans. A. S. M. E.*, vol. 35 (1913), p. 633, tested several forms of tube, comparing their readings with those of a Thomas electric gas meter. He found the best tube to be one made of a 1/4-in. outer and a 1/8-in. inner thin brass tube, 4 or 5 in. long, soldered together at one end, which was tapered for 3/4 in. down to the internal diameter of the inner tube, which was thus given a sharp edge. The outer tube was perforated with a small smooth hole 0.02 in. diameter on each side at the middle of its length. The rear end of the small tube and the annular space between the two tubes were each connected to 1/4 in. upright tubes, from which rubber tubes led to two manometers. The inner tube received the impact pressure and the annular space the static pressure. The difference between the two is the velocity pressure, a direct reading of which could be made by connecting the two rubber tubes, or branches from them, to the two legs of a single manometer. The manometers were U tubes, of glass about 1/2 in. internal diameter, containing gasoline, and were inclined at an angle of 1 vertical to 10 horizontal in order to magnify the readings. The scale was graduated so as to read in hundredths of an inch of water column. To obtain mean velocities and pressures the tube was traversed across two diameters of the pipe, vertical and horizontal, ten readings being taken on each diameter, at points located at the center of five annular areas into which the total area of the pipe was divided. The radial distances of these points from the center of the pipe were 32, 55, 71, 84 and 95 per cent, respectively, of the radius of the pipe. (See Appendix No. 6 of the report of the Power Test Committee of the A. S. M. E., 1915.) The results of these tests showed that accuracy within 1% could be obtained when all readings were obtained with a sufficient degree of refinement and when the Pitot tube was preceded by a length of pipe 20 to 38 times the pipe diameter in order to make the flow as nearly uniform across the section of the pipe as possible.

When readings were taken at the center of a 12-in. galvanized iron pipe the mean pressure was 0.80 of the pressure at the center, corresponding to a mean velocity of  $\sqrt{0.80}$  or 0.894 of the velocity at the center, within a limit of error of 2%. The mean velocity head was obtained by taking the square of the average of the square roots of each of the 20 readings. Tests of Pitot tubes with long narrow slots in the outer tube, instead of the small holes, gave results which were in error from 3.5 to 10%.

**The Thomas Electric Gas Meter**, referred to above, is described in *Trans. A. S. M. E.*, vol. 31, p. 655. It consists in an enlarged section of the gas or air pipe containing an electric heating device with electric instruments for determining both the increase of temperature and the energy absorbed in heating. Given the specific heat, the rise in temperature, and the watts of energy absorbed, the weight of gas flowing in a given time may be computed.

## Flow of Air through an Orifice.

VELOCITY, VOLUME, AND H.P. REQUIRED WHEN AIR UNDER GIVEN PRESSURE IN OUNCES PER SQ. IN. IS ALLOWED TO ESCAPE INTO THE ATMOSPHERE.

(B. F. Sturtevant Co.)

Pressure in ounces per sq. in.	Pressure, inches of water.	Velocity, ft. per min.	Volume through 1 sq. in. effective area, cu. ft. per min.	Horse-power to move the given volume of air.	Horse-power per 1000 cu. ft. per min.	Pressure in ounces per sq. in.	Velocity, ft. per min.	Volume through 1 sq. in. effective area, cu. ft. per min.	Horse-power to move the given volume of air.	Horse-power per 1000 cu. ft. per min.
(1)	(2)	(3)	(4)	(5)	(6)	(1)	(3)	(4)	(5)	(6)
1/8	0.216	1,828	12.69	0.00043	0.0340	2	7,284	50.59	0.02759	0.5454
1/4	0.432	2,585	17.95	0.00122	0.0680	2 1/8	7,507	52.13	0.03021	0.5795
3/8	0.648	3,165	21.93	0.00225	0.1022	2 1/4	7,722	53.63	0.03291	0.6136
1/2	0.864	3,654	25.37	0.00346	0.1363	2 3/8	7,932	55.03	0.03568	0.6476
5/8	1.080	4,084	28.36	0.00483	0.1703	2 1/2	8,136	56.50	0.03852	0.6818
3/4	1.296	4,473	31.06	0.00635	0.2044	2 5/8	8,334	57.88	0.04144	0.7160
7/8	1.512	4,830	33.54	0.00800	0.2385	2 3/4	8,528	59.22	0.04442	0.7500
1	1.728	5,162	35.85	0.00978	0.2728	2 7/8	8,718	60.54	0.04747	0.7841
1 1/8	1.944	5,473	38.01	0.01166	0.3068	3	8,903	61.83	0.05058	0.8180
1 1/4	2.160	5,768	40.06	0.01366	0.3410	3 1/8	9,084	63.08	0.05376	0.8522
1 3/8	2.376	6,048	42.00	0.01575	0.3750	3 1/4	9,262	64.32	0.05701	0.8863
1 1/2	2.592	6,315	43.86	0.01794	0.4090	3 3/8	9,435	65.52	0.06031	0.9205
1 5/8	2.808	6,571	45.63	0.02022	0.4431	3 1/2	9,606	66.71	0.06368	0.9546
1 3/4	3.024	6,818	47.34	0.02260	0.4772	3 5/8	9,773	67.87	0.06710	0.9887
1 7/8	3.240	7,055	49.00	0.02505	0.5112	3 3/4	9,938	69.01	0.07058	1.0227
						3 7/8	10,100	70.14	0.07412	1.0567

The headings of the 3d and 4th columns in the above table have been abridged from the original, which read as follows: Velocity of dry air, 50° F., escaping into the atmosphere through any shaped orifice in any pipe or reservoir in which the given pressure is maintained. Volume of air in cubic feet which may be discharged in one minute through an orifice having an effective area of discharge of one square inch. The 6th column, not in the original, has been calculated by the author. The figures represent the horse-power theoretically required to move 1000 cu. ft. of air of the given pressures through an orifice, without allowance for the work of compression or for friction or other losses of the fan. These losses may amount to 60% or more of the given horse-power.

The change in density which results from a change in pressure has been taken into account in the calculations of the table. The volume of air at a given velocity discharged through an orifice depends upon its shape, and is always less than that measured by its full area. For a given *effective* area the volume is proportional to the velocity. The power required to move air through an orifice is measured by the product of the velocity and the total resisting pressure. This power for a given orifice varies as the cube of the velocity. For a given volume it varies as the square of the velocity. In the movement of air by means of a fan there are unavoidable resistances which, in proportion to their amount, increase the actual power considerably above the amount here given.

**Pipe Lines for Fans and Blowers.** — In installing fans and blowers careful consideration should be given to the pipe line conducting the air from the fan or blower. Bends and turns in the pipe, even of long radii, will cause considerable drop in pressure, and in straight pipe the friction of the moving air is a source of considerable loss. The friction increases with the length of the pipe and is inversely as the diameter. It also varies as the square of the velocity. In long runs of pipe, the increased cost of a larger pipe can often be compensated by the decreased cost of the motor and power for operating the blower.

The advisability of using a large pipe for conveying the air is shown by



the following table which gives the size of pipe which should be used for pressure losses not exceeding one-fourth and one-half ounce per square inch. for various lengths of pipe.

**Diameters of Blast Pipes.**

(B. F. Sturtevant Co., 1908.)

Tons of iron per hour.	Inside dia. of cupola, inches.	Cubic ft. of air per minute.	Length of Pipe in Feet.													
			20		40		60		80		100		120		140	
			Diameter of Pipe with Drop of													
1/4 Oz.	1/2 Oz.	1/4 Oz.	1/2 Oz.	1/4 Oz.	1/2 Oz.	1/4 Oz.	1/2 Oz.	1/4 Oz.	1/2 Oz.	1/4 Oz.	1/2 Oz.	1/4 Oz.	1/2 Oz.	1/4 Oz.	1/2 Oz.	
1	23	500	6	5	7	6	7	6	8	7	9	8	9	8	9	8
2	27	1,000	8	7	9	8	10	9	11	9	11	10	12	11	12	11
3	30	1,500	10	8	11	10	11	10	12	11	13	11	13	12	14	12
4	32	2,000	11	9	12	11	13	12	14	12	15	13	15	14	16	14
5	36	2,500	12	10	14	12	15	13	15	14	16	14	17	15	17	15
6	39	3,000	13	11	15	13	16	14	17	15	18	15	18	16	18	16
7	42	3,500	13	12	15	13	17	15	17	15	18	16	19	17	20	18
8	45	4,000	15	12	16	15	18	15	18	16	19	17	20	18	21	18
9	48	4,500	15	13	17	15	18	16	19	17	20	18	21	19	22	19
10	54	5,000	15	13	18	15	19	17	20	18	21	18	22	19	23	20
11	54	5,500	16	14	18	16	20	17	21	18	22	19	23	20	23	20
12	60	6,000	17	14	19	17	20	17	21	19	22	20	23	21	24	21
13	60	6,500	17	14	19	17	21	18	23	19	23	20	24	21	25	22
14	60	7,000	18	15	20	18	22	19	23	20	24	21	25	22	26	23
15	66	7,500	18	16	21	18	22	19	24	21	25	22	26	22	27	23
16	66	8,000	18	16	22	18	23	20	24	22	26	22	26	23	27	24
17	66	8,500	18	16	22	18	23	20	24	22	26	22	27	24	28	24
18	72	9,000	18	17	22	18	24	21	25	22	27	23	27	24	28	25
19	72	9,500	20	17	23	20	24	22	26	23	28	23	28	25	29	26
20	72	10,000	20	18	23	20	25	22	27	23	28	24	29	25	30	26
21	78	10,500	21	18	24	21	26	23	27	23	29	25	30	26	30	26
22	78	11,000	21	18	24	21	27	23	28	24	29	26	30	27	31	27
23	78	11,500	21	19	25	21	27	24	28	25	30	26	30	27	31	27
24	84	12,000	22	19	25	22	28	24	28	25	31	26	31	27	32	28
25	84	12,500	22	19	26	22	28	24	29	26	31	27	32	28	33	28
26	84	13,000	22	19	26	22	28	24	29	26	31	27	32	28	33	28
27	90	13,500	23	20	26	23	28	24	30	26	31	27	32	28	34	28
28	90	14,000	23	20	27	23	29	25	30	27	32	28	33	29	34	29
29	90	14,500	23	20	27	23	29	26	31	27	32	28	33	29	34	30
30	90	15,000	24	21	27	24	29	26	31	27	32	28	34	30	35	30

The minimum radius of each turn should be equal to the diameter of the pipe. For each turn thus made add three feet in length, when using this table. If the turns are of less radius, the length added should be increased proportionately.

The above table has been constructed on the following basis: A loss of, say, 1/2 oz. pressure was allowed as a standard for the transmission of a given quantity of air through a given length of pipe of any diameter. The increased loss due to increasing the length of pipe was compensated for by increasing the diameter sufficiently to keep the loss still at 1/2 oz. Thus, if 2500 cu. ft. of air is to be delivered per minute through 100 ft. of pipe with a loss of not more than 1/2 oz., a 14-in. pipe will be required. If it is

necessary to increase the length of pipe to 140 ft., a pipe 15 in. diameter will be required if the loss in pressure is not to exceed  $\frac{1}{2}$  oz. In deciding the size of pipe the loss in pressure in the pipe must be added to the pressure to be maintained at the fan or blower, if the tabulated efficiency of the latter is to be secured at the delivery end of the pipe.

**Centrifugal Ventilators for Mines.**—Of different appliances for ventilating mines various forms of centrifugal machines having proved their efficiency have now almost completely replaced all others. Most if not all of the machines in use in this country are of this class, being either open-periphery fans, or closed, with chimney and spiral casing, of a more or less modified Guibal type. The theory of such machines has been demonstrated by Mr. Daniel Murgue in "Theories and Practices of Centrifugal Ventilating Machines," translated by A. L. Stevenson, and is discussed in a paper by R. Van A. Norris, *Trans. A. I. M. E.*, xx, 637. From this paper the following formulæ are taken:

Let  $a$  = area in sq. ft. of an orifice in a thin plate, of such area that its resistance to the passage of a given quantity of air equals the resistance of the mine;

$o$  = orifice in a thin plate of such area that its resistance to the passage of a given quantity of air equals that of the machine;

$Q$  = quantity of air passing in cubic feet per minute;

$V$  = velocity of air passing through  $a$  in feet per second;

$V_0$  = velocity of air passing through  $o$  in feet per second;

$h$  = head in feet air-column to produce velocity  $V$ ;

$h_0$  = head in feet air-column to produce velocity  $V_0$ .

$$Q = 0.65 a V; \quad V = \sqrt{2gh}; \quad Q = 0.65 a \sqrt{2gh};$$

$$a = \frac{Q}{0.65 \sqrt{2gh}} = \text{equivalent orifice of mine};$$

or, reducing to water-gauge in inches and quantity in thousands of cubic feet per minute,

$$a = \frac{0.403 Q}{\sqrt{W.G.}}; \quad Q = 0.65 o V_0; \quad V_0 = \sqrt{2gh_0}; \quad Q = 0.65 o \sqrt{2gh_0};$$

$$o = \sqrt{\frac{Q^2}{0.65^2 h_0 2g}} = \text{equivalent orifice of machine.}$$

The theoretical depression which can be produced by any centrifugal ventilator is double that due to its tangential speed. The formula

$$H = \frac{T^2}{2g} - \frac{V^2}{2g},$$

in which  $T$  is the tangential speed,  $V$  the velocity of exit of the air from the space between the blades, and  $H$  the depression measured in feet of air-column, is an expression for the theoretical depression which can be produced by an uncovered ventilator: this reaches a maximum when the air leaves the blades without speed, that is,  $V = 0$ , and  $H = T^2 \div 2g$ .

Hence the theoretical depression which can be produced by any uncovered ventilator is equal to the height due to its tangential speed, and one-half that which can be produced by a covered ventilator with expanding chimney. Practical considerations in the design of the fan wheel and casing will probably cause the actual results obtained with fans to vary considerably from these formulæ.

So long as the condition of the mine remains constant:

(1) The volume produced by any ventilator varies directly as the speed of rotation.

(2) The depression produced by any ventilator varies as the square of the speed of rotation.

(3) For the same tangential speed with decreased resistance the quantity of air increases and the depression diminishes.

The following table shows a few results, selected from Mr. Norris's paper, giving the range of efficiency which may be expected under different circumstances. Details of these and other fans, with diagrams of the results, are given in the paper.

Experiments on Mine-Ventilating Fans.

Fan.	Revolutions per minute, fan.	Peripheral speed, feet per min.	Cubic feet of air per minute.	Cubic feet of air per revolution.	Cubical contents of fan-blades.	Cubic feet of air per 100 ft. periphery motion.	Water-gauge, inches.	Horse-power in air.	Indicated horse-power of engine.	Efficiency of engine and fan.	Equivalent orifice of mine, square feet.
A	84	5517	236,684	2818	3040	4290	1.80	67.13	88.40	75.9	} Av'ge 80
	100	6282	336,862	3369	3040	5393	2.50	132.70	155.43	85.4	
	111	6973	347,396	3130	3040	5002	3.20	175.17	209.64	83.6	
	123	7727	394,100	3204	3040	5100	3.60	223.56	295.21	75.7	
B	100	6282	188,888	1889	1520	3007	1.40	41.67	97.99	42.5	} 22
	130	8167	274,876	2114	1520	3366	2.00	86.63	194.95	44.6	
C	59	3702	59,587	1010	1520	1610	1.20	11.27	16.76	67.83	} 32
	83	5208	82,969	1000	1520	1593	2.15	27.86	48.54	57.38	
D	40	3140	49,611	1240	3096	1580	0.87	6.80	13.82	49.2	} 83
	70	5495	137,760	1825	3096	2507	2.55	55.35	67.44	82.07	
E	50	2749	147,232	2944	1522	5356	0.50	11.60	28.55	40.63	} 26.9
	69	3793	205,761	2982	1522	5451	1.00	32.42	45.98	70.50	
F	96	5278	299,600	3121	1522	5676	2.15	101.50	120.64	84.10	} 38.3
	200	7540	133,198	666	746	1767	3.35	70.30	102.79	68.40	
	200	7540	180,809	904	746	2398	3.05	86.89	129.07	67.30	
	200	7540	209,150	1046	746	2774	2.80	92.50	150.08	61.70	
G	10	785	28,896	2890	3022	3680	0.10	0.45	1.30	35.	} 52
	20	1570	57,120	2856	3022	3637	0.20	1.80	3.70	49.	
	25	1962	66,640	2665	3022	3399	0.29	2.90	6.10	48.	
	30	2355	73,080	2436	3022	3103	0.40	4.60	9.70	47.	
	35	2747	94,080	2688	3022	3425	0.50	7.40	15.00	48.	
	40	3140	112,000	2800	3022	3567	0.70	12.30	24.90	49.	
	50	3925	132,700	2654	3022	3381	0.90	18.80	38.80	48.	
	60	4710	173,600	2893	3022	3686	1.35	36.90	66.40	55.	
	70	5495	203,280	2904	3022	3718	1.80	57.70	107.10	54.	
	80	6280	222,320	2779	3022	3540	2.25	78.80	152.60	52.	

Type of fan.	Diam.	Width.	No. inlets.	Diam. inlets.
A. Guibal, double .....	20 ft.	6 ft.	4	8 ft. 10 in.
B. Same, only left hand running	20	6	4	8 10
C. Guibal.....	20	6	2	8 10
D. Guibal.....	25	8	1	11 6
E. Guibal, double.....	17 1/2	4	4	8
F. Capell.....	12	10	2	7
G. Guibal.....	25	8	1	12

An examination of the detailed results of each test in Mr. Norris's table shows a mass of contradictions from which it is exceedingly difficult to draw any satisfactory conclusions. The following, he states, appear to be more or less warranted by some of the figures:

1. *Influence of the Condition of the Airways on the Fan.* — Mines with varying equivalent orifices give air per 100 ft. speed of tip of fan, within limits as follows, the quantity depending on the resistance of the mine:



Equivalent orifice. sq. ft.	Cu. ft. air per 100 ft. speed of fan.	Average.	Equivalent orifice. sq. ft.	Cu. ft. air per 100 ft. speed of fan.	Average.
Under 20	1100 to 1700	1300	60 to 70	3300 to 5100	4000
20 to 30	1300 to 1800	1600	70 to 80	4000 to 4700	4400
30 to 40	1500 to 2500	2100	80 to 90	3000 to 5600	4800
40 to 50	2300 to 3500	2700	90 to 100	.....	.....
50 to 60	2700 to 4800	3500	100 to 114	5200 to 6200	5700

The influence of the mine on the efficiency of the fan does not seem to be very clear. Eight fans, with equivalent orifices over 50 square feet, give efficiencies over 70%; four, with smaller equivalent mine-orifices, give about the same figures; while, on the contrary, six fans, with equivalent orifices of over 50 square feet, give lower efficiencies, as do ten fans, all drawing from mines with small equivalent orifices. It would seem that, on the whole, large airways tend to assist somewhat in attaining high efficiency.

2. *Influence of the Diameter of the Fan.* — This seems to be practically *nil*, the only advantage of large fans being in their greater width and the lower speed required of the engines.

3. *Influence of the Width of a Fan.* — This appears to be small as regards the efficiency of the machine; but the wider fans are, as a rule, exhausting more air. However, increasing the width of the fan of a given diameter causes an increase in the velocity of the air through the wheel inlet, and this increased velocity will become at a certain point a serious loss and will decrease the mechanical efficiency.

4. *Influence of Shape of Blades.* — This appears, within reasonable limits, to be practically *nil*. Thus, six fans with tips of blades curved forward, three fans with flat blades, and one with blades curved back to a tangent with the circumference, all give very high efficiencies — over 70 per cent. A prominent manufacturer claims, however, that his tests show a higher efficiency with vanes curved forward as compared with straight or backwardly curved vanes.

5. *Influence of the Shape of the Spiral Casing.* — This appears to be considerable. The shapes of spiral casing in use fall into two classes, the first presenting a large spiral, beginning at or near the point of cut-off, and the second a circular casing reaching around three-quarters of the circumference of the fan, with a short spiral reaching to the *evasée* chimney. Fans having the first form of casing appear to give in almost every case high efficiencies.

Fans that have a spiral belonging to the first class, but very much contracted, give only medium efficiencies. It seems probable that the proper shape of spiral casing would be one of such form that the air between each pair of blades could constantly and freely discharge into the space between the fan and casing, the whole being swept along to the *evasée* chimney. This would require a spiral beginning near the point of cut-off, enlarging by gradually increasing increments, to allow for the slowing of the air caused by its friction against the casing, and reaching the chimney with an area such that the air could make its exit with its then existing speed — somewhat less than the periphery-speed of the fan.

6. *Influence of the Shutter.* — The shutter certainly appears to be an advantage, as by it the exit area can be regulated to suit the varying quantity of air given by the fan, and in this way re-entries can be prevented. It is not uncommon to find shutterless fans, into the chimneys of which bits of paper may be dropped, which are drawn *into* the fan, make the circuit, and are again thrown out. This peculiarity has not been noticed with fans provided with shutters.

7. *Influence of the Speed at which a Fan is Run.* — It is noticeable that most of the fans giving high efficiency were running at a rather high periphery velocity. The best speed seems to be between 5000 and 6000 feet per minute. The fans appear to reach a maximum efficiency at somewhere about the speed given, and to decrease rapidly in efficiency when this maximum point is passed. The same manufacturer mentioned in note 4 states that the efficiency is not affected by the tip speed, providing that the comparison is always made at the same point in the efficiency curve.

In discussion of Mr. Norris's paper, Mr. A. H. Storrs says: From the "cubic feet per revolution" and "cubical contents of fan-blades," as given in the table, we find that the enclosed fans empty themselves from one-half to twice per revolution, while the open fans are emptied from one and three-quarters to nearly three times; this for fans of both types, on mines covering the same range of equivalent orifices. One open fan, on a very large orifice, was emptied nearly four times, while a closed fan, on a still larger orifice, only shows one and one-half times. For the open fans the "cubic feet per 100 ft. motion" is greater, in proportion to the fan width and equivalent orifice, than for the enclosed type. Notwithstanding this apparently free discharge of the open fans, they show very low efficiencies.

As illustrating the very large capacity of centrifugal fans to pass air, if the conditions of the mine are made favorable, a 16-ft. diam. fan, 4 ft. 6 in. wide, at 130 revolutions, passed 360,000 cu. ft. per min., and another, of same diameter, but slightly wider and with larger intake circles, passed 500,000 cu. ft., the water-gauge in both instances being about  $1\frac{1}{2}$  in.

T. D. Jones says: The efficiency reported in some cases by Mr. Norris is larger than I have ever been able to determine by experiment. My own experiments, recorded in the Pennsylvania Mine Inspectors' Reports from 1875 to 1881, did not show more than 60% to 65%.

## DISK FANS.

**Efficiency of Disk Fans.** — Prof. A. B. W. Kennedy (*Industries*, Jan. 17, 1890) made a series of tests on two disk fans, 2 and 3 ft. diameter, known as the Verity Silent Air-propeller. The principal results and conclusions are condensed as below.

	Propeller, 2 ft. diam.			Propeller, 3 ft. diam.		
Speed of fan, revolutions per minute..	750	676	577	576	459	373
Net H.P. to drive fan and belt.....	0.42	0.32	0.227	1.02	0.575	0.324
Cubic feet of air per minute.....	4,183	3,830	3,410	7,400	5,800	4,470
Mean velocity of air in 3-ft. flue, feet per minute.....	593	543	482	1,046	820	632
Mean velocity of air in flue, same diameter as fan.....	1,330	1,220	1,085	.....	.....	.....
Cu. ft. of air per min. per effective H.P	9,980	11,970	15,000	7,250	10,070	13,800
Motion given to air per rev. of fan, ft..	1.77	1.81	1.88	1.82	1.79	1.70
Cubic feet of air per rev. of fan .....	5.58	5.66	5.90	12.8	12.6	12.0

In each case the efficiency of the fan, that is, the quantity of air delivered per effective horse-power, increases very rapidly as the speed diminishes, so that lower speeds are much more economical than higher ones. On the other hand, as the quantity of air delivered per revolution is very nearly constant, the actual useful work done by the fan increases almost directly with its speed. Comparing the large and small fans with about the same air delivery, the former (running at a much lower speed, of course) is much the more economical. Comparing the two fans running at the same speed, however, the smaller fan is very much the more economical. The delivery of air per revolution of fan is very nearly directly proportional to the area of the fan's diameter.

The air delivered per minute by the 3-ft. fan is nearly  $12.5R$  cubic feet ( $R$  being the number of revolutions made by the fan per minute). For the 2-ft. fan the quantity is  $5.7R$  cubic feet. For either of these or any other similar fans of which the area is  $A$  square feet, the delivery will be about  $1.8AR$  cubic feet. Of course any change in the pitch of the blades might entirely change these figures.

The net H.P. taken up is not far from proportional to the square of the number of revolutions above 100 per minute. Thus for the 3-ft. fan the net H.P. is  $\frac{(R-100)^2}{200,000}$ , while for the 2-ft. fan the net H. P is  $\frac{(R-100)^2}{1,000,000}$ .

The denominators of these two fractions are very nearly proportional inversely to the square of the fan areas or the fourth power of the fan

diameters. The net H.P. required to drive a fan of diameter  $D$  feet or area  $A$  square feet, at a speed of  $R$  revolutions per minute, will therefore be approximately  $\frac{D^4 (R - 100)^2}{17,000,000}$  or  $\frac{A^2 (R - 100)^2}{10,400,000}$ .

The 2-ft. fan was noiseless at all speeds. The 3-ft. fan was also noiseless up to over 450 revolutions per minute.

**Experiments made with a Blackman Disk Fan, 4 ft. diam. by Geo. A. Suter,** to determine the volumes of air delivered under various conditions, and the power required; with calculations of efficiency and ratio of increase of power to increase of velocity, by G. H. Babcock. (*Trans. A. S. M. E.*, vii. 547):

Rev. per min.	Cu. ft. of Air delivered per min., $V$ .	Horse-power, HP.	Water-gauge, in., $h$ .	Ratio of Increase of Speed.	Ratio of Increase of Delivery.	Ratio of Increase of Power.	Exponent $x$ , $HP \propto V^x$ .	Exponent $y$ , $h \propto V^y$ .	Efficiency of Fan.
350	25,797	0.65	.....	.....	.....	.....	.....	.....	1.682
440	32,575	2.29	.....	1.257	1.262	3.523	5.4	.....	.9553
534	41,929	4.42	.....	1.186	1.287	1.843	2.4	.....	1.062
612	47,756	7.41	.....	1.146	1.139	1.677	3.97	.....	.9358
	For series	.....	.....	1.749	1.851	11.140	4.	.....	.....
340	20,372	0.76	.....	.....	.....	.....	.....	.....	.7110
453	26,660	1.99	.....	1.332	1.308	2.618	3.55	.....	.6063
536	31,649	3.86	.....	1.183	1.187	1.940	3.86	.....	.5205
627	36,543	6.47	.....	1.167	1.155	1.676	3.59	.....	.4802
	For series	.....	.....	1.761	1.794	8.513	3.63	.....	.....
340	9,983	1.12	0.28	.....	.....	.....	.....	.....	.3939
430	13,017	3.17	0.47	1.265	1.304	2.837	3.93	1.95	.3046
534	17,018	6.07	0.75	1.242	1.307	1.915	2.25	1.74	.3319
570	18,649	8.46	0.87	1.068	1.096	1.394	3.63	1.60	.3027
	For series	.....	.....	1.676	1.704	7.554	3.24	1.81	.....
330	8,399	1.31	0.26	.....	.....	.....	.....	.....	.2631
437	10,071	3.27	0.45	1.324	1.199	3.142	6.31	3.06	.2188
516	11,157	6.00	0.75	1.181	1.108	1.457	3.66	4.96	.2202
	For series	.....	.....	1.563	1.329	4.580	5.35	3.72	.....

*Nature of the Experiments.* — First Series: Drawing air through 30 ft. of 48-in. diam. pipe on inlet side of the fan.

Second Series: Forcing air through 30 ft. of 48-in. diam. pipe on outlet side of the fan.

Third Series: Drawing air through 30 ft. of 48-in. pipe on inlet side of the fan — the pipe being obstructed by a diaphragm of cheese-cloth.

Fourth Series: Forcing air through 30 ft. of 48-in. pipe on outlet side of fan — the pipe being obstructed by a diaphragm of cheese-cloth.

Mr. Babcock says concerning these experiments: The first four experiments are evidently the subject of some error, because the efficiency is such as to prove on an average that the fan was a source of power sufficient to overcome all losses and help drive the engine besides. The second series is less questionable, but still the efficiency in the first two experiments is larger than might be expected. In the third and fourth series the resistance of the cheese-cloth in the pipe reduces the efficiency largely, as would be expected. In this case the value has been calculated from the height equivalent to the water-pressure, rather than the actual velocity of the air.

This record of experiments made with the disk fan shows that this kind of fan is not adapted for use where there is any material resistance to the flow of the air. In the centrifugal fan the power used is nearly proportioned to the amount of air moved under a given head, while in this fan the power required for the same number of revolutions of the fan increases very materially with the resistance, notwithstanding the quantity of air moved is at the same time considerably reduced. In fact from the inspec-



tion of the third and fourth series of tests, it would appear that the power required is very nearly the same for a given pressure, whether more or less air be in motion. It would seem that the main advantage, if any, of the disk fan over the centrifugal fan for slight resistances consists in the fact that the delivery is the full area of the disk, while with centrifugal fans intended to move the same quantity of air the opening is much smaller.

It will be seen by columns 8 and 9 of the table that the power used increased much more rapidly than the cube of the velocity, as in centrifugal fans. The different experiments do not agree with each other, but a general average may be assumed as about the cube root of the eleventh power.

**Capacity of Disk Fans.** (C. L. Hubbard, *The Metal Worker*, Sept. 5, 1908.)—The rated capacities given in catalogues are for fans revolving in free air—that is, mounted in an opening without being connected with ducts or subject to other frictional resistance.

The following data, based upon tests, apply to fans working against a resistance equivalent to that of a shallow heater of open pattern, and connecting with ducts of medium length through which the air flows at a velocity not greater than 600 or 800 ft. per minute. Under these conditions a good type of fan will propel the air in a direction parallel to the shaft, a distance equal to about 0.7 of its diameter at each revolution. From this we have the equation  $Q = 0.7 D \times R \times A$ , in which  $Q =$  cu. ft. of air discharged per minute;  $D =$  diam. of fan, in ft.;  $R =$  revs. per min.;  $A =$  area of fan, in sq. ft. The following table is calculated on this basis.

Diam. of fan, in.	18	24	30	36	42	48	54	60	72	84	96
Cu. ft per rev.	1.85	4.40	8.59	14.8	23.6	35.2	50.1	68.7	118.7	188.6	281.5
Revolutions per min. for velocity of air through fan = 1000 ft. per min.	952	714	571	476	408	357	317	286	238	204	179

The velocity of the air through the fan is proportional to the number of revolutions. For the conditions stated the H.P. required per 1000 cu. ft. of air moved will be about 0.16 when the velocity through the fan is 1000 ft. per min., 0.14 for a velocity of 800 ft., and 0.18 for 1200 ft. For a fan moving in free air the required speed for moving a given volume of air will be about 0.6 of the number of revolutions given above and the H.P. about 0.3 of that required when moving against the resistance stated.

**POSITIVE ROTARY BLOWERS.**

**Rotary Blowers, Centrifugal Fans, and Piston Blowers.** (Catalogue of the Connersville Blower Co.)—In ordinary work the advantage of a positive blower over a fan begins at about 8 oz. pressure, and the efficiency of the positive blower increases from 8 oz. as the pressure goes up to a point where the ordinary centrifugal fan fails entirely. The highest efficiency of rotary blowers is when they are working against pressures ranging between 1 and 8 lbs.

Fans, when run at constant speed, cannot be made to handle a constant volume of fluid when the pressure is variable; and they cannot give a high efficiency except for low and uniform pressures.

When a fan blower is used to furnish blast for a cupola it is driven at a constant speed, and the amount of air discharged by it varies according to the resistance met with in the cupola. With a positive blower running at a constant speed, however, there is a constant volume of air forced into the cupola, regardless of changing resistance.

A rotary blower of the two-impeller type is not an economical compressor, because the impellers are working against the full pressure at all times, while in an ideal blowing engine the theoretical mean effective pressure on the piston, when discharging air at 15 lbs. pressure, is 11½ lbs. For high pressures, on account of the increase of leakage and the increase of power required because it does not compress gradually, the rotary blower must give way to the piston type of machine. Commercially, the line is crossed at about 8 lbs. pressure.

1. A fan is the cheapest in first cost, and if properly applied may be used economically for pressures up to 8 oz.

2. A rotary blower costs more than a fan, but much less than a blowing engine; is more economical than either between 8 oz. and 8 lbs. pressure, and can be arranged to give a constant pressure or a constant volume.

3. Piston machines cost much more than rotary blowers, but should be used for continuous duty for pressures above 8 lbs., and may be economical if they are properly constructed and not run at too high a piston speed.

The horse-power required to operate rotary blowers is proportional to the volume and pressure of air discharged. In making estimates for power it is safe to assume that for each 1000 cu. ft. of free air discharged, at one pound pressure, 5 H.P. should be provided.

**Test of a Rotary Blower.** (Connersville Blower Co.) — The test was made in 1904 on two 39 × 84 in. blowers coupled direct to two 12 and 24 × 36 in. compound Corliss engines. The results given below are for the combined units.

Air pressure, lbs....	0	0.05	0.5	1.0	1.5	2.	2.5	3.	3.5
Engine, I.H.P.....	19.30	23.76	52.83	100.91	132.67	176.11	223.20	256.87	287.56
Displacement, cu.ft. ....	19,212	18,727	18,508	18,344	18,200	18,028	17,966	17,863	17,863
Efficiency.....	.....	.....	68.5	79	84	85.6	86	86	85.9

In calculating the efficiency the theoretical horse-power was taken as the power required to compress adiabatically and to discharge the net amount of air at the different pressures and at the same altitude. The test was made up to 3.5 lbs. only. Estimated efficiencies for higher pressures from an extension of the plotted curve are: 6 lbs. 84%, 8 lbs. 82%, 10 lbs. 79.5%. The theoretical discharge of the blower was 19,250 cu. ft.

#### CAPACITY OF ROTARY BLOWERS FOR CUPOLAS.

Cu. ft per rev.	Revs. per min.	Tons per hour.	Suitable for cupola in. diam.*	Cu. ft. per rev.	Revs. per min.	Tons per hour.	Suitable for cupola in. diam.
1.5	{ 200 400	1 2	} 18 to 20	45	{ 135 165	12 15	} 54 to 66
3.3	{ 175 335	1 2			} 24 to 27	{ 200 130	
6	{ 185 275	2 3	} 28 to 32	57	{ 155 185	18 21	} 60 to 72
10	{ 200 250	4 5			} 32 to 38	{ 140 160	
13	{ 150 190	4 5	} 32 to 40	84	{ 185 125	24 21	} 72 to 90
	{ 175 150	6 1/2 5			{ 145 160	24 27	
17	{ 205 250	6 1/2 8 1/2	} 36 to 45	100	{ 120 135	24 27	} 84 to 96
	{ 166 200	8 10			{ 160 115	30 27	
24	{ 240 150	12 10	} 42 to 54	118	{ 130 140	30 33	} Two cupolas 60 to 66
	{ 180 210	12 14			} 48 to 60		

\* Inside diam. The capacity in tons per hour is based on 30,000 cu. ft. of air per ton of iron melted.

For smith fires: an ordinary fire requires about 60 cu. ft. per min.

For oil furnaces: an ordinary furnace burns about 2 gallons of oil per hour and 1800 cu. ft. of air should be provided for each gallon of oil. For each 100 cu. ft. of air discharged per minute at 16 oz. pressure, 1/2 H.P. should be provided.

Sizes of small blowers.	173	288	576 cu. in. per rev.
Revs. per min.....	800 to 1500	500 to 900	300 to 600
Diam. of outlet, in....	2 1/2	2 1/2	3

ROTARY GAS EXHAUSTERS.

Cu. ft. per rev.....	2/3	1 1/2	3.3	6	10	13	17	24	33
Rev. per min.....	200	180	170	160	150	150	140	130	120
Diam. of pipe opening.....	4	6	8	10	12	12	16	16	20
Cu. ft. per rev.....	45	57	65	84	100	118	155	200	300
Rev. per min.....	110	100	95	90	85	82	80	80	75
Diam. pipe opening	20	24	24	30	30	30	36	36	42

There is no gradual compressing of air in a rotary machine, and the unbalanced areas of the impellers are working against the full difference of pressure at all times. The possible efficiency of such a machine under ordinary temperature and conditions of atmosphere, assuming no mechanical friction, leakage, nor radiation of heat of compression, would be as follows:

Gauge pres. lb.....	1	2	3	4	5	10	15
Efficiency %.....	97.5	95.5	93.3	91.7	90	82.7	76.7

The proper application of rotary positive machines when operating in air or gas under differences of pressures from 8 oz. to 5 lbs. is where constant quantities of fluid are required to be delivered against a variable resistance, or where a constant pressure is required and the volume is variable. These are the requirements of gas works, pneumatic-tube transmission (both the vacuum and pressure systems), foundry cupolas, smelting furnaces, knobbling fires, sand blast, burning of fuel oil, conveying granular substances, the operation of many kinds of metallurgical furnaces, etc. — J. T. Wilkin, *Trans. A. S. M. E.*, Vol. xxiv.

STEAM-JET BLOWER AND EXHAUSTER

**The Steam-jet as a Means for Ventilation.** — Between 1810 and 1850 the steam-jet was employed to a considerable extent for ventilating English collieries, and in 1852 a committee of the House of Commons reported that it was the most powerful and at the same time the cheapest method for the ventilation of mines; but experiments made shortly afterwards proved that this opinion was erroneous, and that furnace ventilation was less than half as expensive, and in consequence the jet was soon abandoned as a permanent method of ventilation.

For an account of these experiments see *Colliery Engineer*, Feb., 1890. The jet, however, is sometimes advantageously used as a substitute, for instance, in the case of a fan standing for repairs, or after an explosion, when the furnace may not be kept going, or in the case of the fan having been rendered useless.

**A Blower and Exhauster** is made by Schutte & Koerting Co., Philadelphia, on the principle of the steam-jet ejector. The following is a table of capacities.

Diameter of Pipes, Inches.		Capacity per Hour, Cu. ft.	Diameter of Pipes, Inches.		Capacity Per Hour, Cu. ft.	Diameter of Pipes, Inches.		Capacity Per Hour, Cu. ft.
Air.	Steam.		Air.	Steam.		Air.	Steam.	
1/2	1/4	300	2	3/4	4,000	5	2	27,000
3/4	3/8	600	2 1/2	1	6,000	6	2	35,000
1	3/8	1,000	3	1 1/4	12,000	7	2 1/2	48,000
1 1/2	1/2	2,000	4	1 1/2	18,000	8	3	60,000

When used as exhausters with a steam pressure of 45 lb., these machines will produce a vacuum of 20 in. mercury (23.3 ft. water column), but they can be specially constructed to produce a vacuum of 25 in. mercury (29.3 ft. water column).



When used as compressors, they will operate against a counter-pressure equal to  $1/7$  of the steam pressure.

Another steam-jet blower is used for boiler-firing, ventilation, and similar purposes where a low counter-pressure or rarefaction meets the requirements.

The volumes as given in the following table of capacities are under the supposition of a steam-pressure of 60 lbs. and a counter-pressure of, say, from 0.5 to 2 inches of water:

Diameter in Inches.			Capacity per Hour, Cubic Feet.	Diameter in Inches.			Capacity per Hour, Cubic Feet.	Diameter in Inches.			Capacity per Hour, Cubic Feet.
Air Inlet.	Air Disch.	Steam Pipe.		Air Inlet.	Air Disch.	Steam Pipe.		Air Inlet.	Air Disch.	Steam Pipe.	
4	3	$3/8$	10,000	11	7	$3/4$	60,000	18	14	$1 1/4$	240,000
5	4	$1/2$	20,000	12	8	$3/4$	90,000	24	18	$1 1/2$	500,000
8	5	$1/2$	30,000	14	10	1	120,000	32	24	2	1,000,000
9	6	$3/4$	45,000	16	12	1	180,000	42	32	$2 1/2$	2,000,000

Maximum coal burning capacity per hour = cu. ft. air per hr.  $\div$  200.

### BLOWING-ENGINES.

**Blowing-engines.** — The following table showing dimensions, capacity, etc., of Corliss horizontal cross-compound condensing blowing engines is condensed from a table published about 1901 by the Philadelphia Engineering Works. Similar engines are built by William Tod & Co., Youngstown, Ohio, and other builders.

#### Corliss Horizontal Cross-compound Condensing Blowing-engines.

Indicated Horse-power.		Revs. per min.	Cu. ft. Free Air per min.	Blast-pressure per sq. in., lb.	h.p. Cylinder, Diam., in.	l.p. Cylinder, Diam., in.	Blast Cylinders, Diam., in.	Stroke of All Cylinders, in.	Approx. Shipping Weight, lb.	Approx. Shipping Weight of Vert. Eng., lb.
15 Exp. 125 lb. Steam.	13 Exp. 100 lb. Steam.									
1,596	2,280	60	45,600	15	44	78	(2) 84	60	505,000	605,000
	2,060	60	45,600	12	42	72	(2) 84	60	475,000	550,000
	.....	60	45,600	10	32	60	(2) 84	60	355,000	436,000
	1,980	60	39,600	15	40	72	(2) 78	60	445,000	545,000
	1,702	60	39,600	12	38	70	(2) 78	60	425,000	491,000
	1,386	60	39,600	10	36	66	(2) 78	60	415,000	450,000
	1,175	60	23,500	15	34	60	(2) 72	60	340,000	430,000
822	60	23,500	10	28	50	(2) 72	60	270,000	300,000	

Vertical engines are built of the same dimensions as above, except that the stroke is 48 in. instead of 60, and they are run at a higher number of revolutions to give the same piston-speed and the same I.H.P.

The calculations of power, capacity, etc., of blowing-engines are the same as those for air-compressors. They are built without any provision for cooling the air during compression. About 400 feet per minute is the usual piston-speed for recent forms of engines, but with positive air-valves, which have been introduced to some extent, this speed may be increased. The efficiency of the engine, that is, the ratio of the I.H.P. of the air-cylinder to that of the steam-cylinder, is usually taken at 90 per cent, the losses by friction, leakage, etc., being taken at 10 per cent.

**Horse-power of Steam Cylinders of Blowing-engines.**—(Wm. Tod & Co., 1914.) To find the indicated horse-power to be developed in the steam cylinders of a blowing-engine, multiply the number of

cubic feet of free air to be compressed per minute by the figures given below for the respective pressures named.

Gage press. lb.									
per sq. in. . . . .	5	10	15	20	25	30	35	40	
Factor . . . . .	0.0226	.0415	.0577	.0722	.0853	.0973	.1084	.1187	

These factors are based on the theoretical horse-power required to compress and deliver 1 cu. ft. of air to the pressure stated, plus an allowance of 15%, which is stated to be about right for mechanically-operated air valves. With poppet air valves the loss may be about 10%.

## HEATING AND VENTILATION.

**Ventilation.** (A. R. Wolff, *Stevens Indicator*, April, 1890.) — The popular impression that the impure air falls to the bottom of a crowded room is erroneous. There is a constant mingling of the fresh air admitted with the impure air due to the law of diffusion of gases, to difference of temperature, etc. The process of ventilation is one of dilution of the impure air by the fresh, and a room is properly ventilated in the opinion of the hygienists when the dilution is such that the carbonic acid in the air does not exceed from 6 to 8 parts by volume in 10,000. Pure country air contains about 4 parts CO<sub>2</sub> in 10,000, and badly-ventilated quarters as high as 80 parts.

An ordinary man exhales 0.6 of a cubic foot of CO<sub>2</sub> per hour. New York gas gives out 0.75 of a cubic feet of CO<sub>2</sub> for each cubic foot of gas burnt. An ordinary lamp gives out 1 cu. ft. of CO<sub>2</sub> per hour. An ordinary candle gives out 0.3 cu. ft. per hour. [The use of gaslight for interior lighting does not affect the atmosphere deleteriously. See pamphlet issued by National Commercial Gas Assn., 1914.]

To determine the quantity of air to be supplied to the inmates of an unlighted room, to dilute the air to a desired standard of purity, we can establish equations as follows:

Let  $v$  = cubic feet of fresh air to be supplied per hour.

$r$  = cubic feet of CO<sub>2</sub> in each 10,000 cu. ft. of the entering air;

$R$  = cubic feet of CO<sub>2</sub> which each 10,000 cu. ft. of the air in the room may contain for proper health conditions;

$n$  = number of persons in the room;

0.6 = cubic feet of CO<sub>2</sub> exhaled by one man per hour.

Then  $\frac{v \times r}{10,000} + 0.6 n$  equals cubic feet of CO<sub>2</sub> communicated to the room during one hour.

This value divided by  $v$  and multiplied by 10,000 gives the proportion of CO<sub>2</sub> in 10,000 parts of the air in the room, and this should equal  $R$ , the standard of purity desired. Therefore

$$R = \frac{10,000 \left[ \frac{v \times r}{10,000} + 0.6 n \right]}{v}, \text{ or } v = \frac{6000 n}{R - r}.$$

If we place  $r$  at 4 and  $R$  at 6,  $v = 6000 n \div (6 - 4) = 3000 n$ , or the quantity of air to be supplied per person is 3000 cubic feet per hour.

If the original air in the room is of the purity of external air, and the cubic contents of the room is equal to 100 cu. ft. per inmate, only  $3000 - 100 = 2900$  cu. ft. of fresh air from without will have to be supplied the first hour to keep the air within the standard purity of 6 parts of CO<sub>2</sub> in 10,000. If the cubic contents of the room equals 200 cu. ft. per inmate, only  $3000 - 200 = 2800$  cu. ft. will have to be supplied the first hour to keep the air within the standard purity, and so on.

Again, if we only desire to maintain a standard of purity of 8 parts of carbonic acid in 10,000, the equation gives as the required air-supply per hour

$$v = \frac{6000}{8 - 4} n = 1500 n, \text{ or } 1500 \text{ cu. ft. of fresh air per inmate per hour.}$$

Cubic feet of air containing 4 parts of carbonic acid in 10,000 necessary per person per hour to keep the air in room at the composition of

6 7 8 9 10 15 20 parts of CO<sub>2</sub> in 10,000.  
3000 2000 1500 1200 1000 545 375 cubic feet.

If the original air in the room is of purity of external atmosphere (4 parts of carbonic acid in 10,000), the amount of air to be supplied the first hour, for given cubic spaces per inmate, to have given standards of purity not exceeded at the end of the hour, is obtained from the following table:

Cubic Feet of Space in Room per Individual.	Proportion of Carbonic Acid in 10,000 Parts of the Air, not to be Exceeded at End of Hour.						
	6	7	8	9	10	15	20
	Cubic Feet of Air, of Composition 4 Parts of Carbonic Acid in 10,000, to be Supplied the First Hour.						
100	2900	1900	1400	1100	900	445	275
200	2800	1800	1300	1000	800	345	175
300	2700	1700	1200	900	700	245	75
400	2600	1600	1100	800	600	145	None
500	2500	1500	1000	700	500	45	.....
600	2400	1400	900	600	400	None	.....
700	2300	1300	800	500	300	.....	.....
800	2200	1200	700	400	200	.....	.....
900	2100	1100	600	300	100	.....	.....
1000	2000	1000	500	200	None	.....	.....
1500	1500	500	None	None	.....	.....	.....
2000	1000	None	.....	.....	.....	.....	.....
2500	500	.....	.....	.....	.....	.....	.....

It is exceptional that systematic ventilation supplies the 3000 cubic feet per inmate per hour, which adequate health considerations demand. For large auditoriums in which the cubic space per individual is great, and in which the atmosphere is thoroughly fresh before the rooms are occupied, and the occupancy is of two or three hours' duration, the systematic air-supply may be reduced, and 2000 to 2500 cubic feet per inmate per hour is a satisfactory allowance.

In hospitals where, on account of unhealthy excretions of various kinds, the air-dilution must be largest, an air-supply of from 4000 to 6000 cubic feet per inmate per hour should be provided, and this is actually secured in some hospitals. A report dated March 15, 1882, by a commission appointed to examine the public schools of the District of Columbia, says:

"In each class-room not less than 15 square feet of floor-space should be allotted to each pupil. In each class-room the window-space should not be less than one-fourth the floor-space, and the distance of desk most remote from the window should not be more than one and a half times the height of the top of the window from the floor. The height of the class-room should never exceed 14 feet. The provisions for ventilation should be such as to provide for each person in a class-room not less than 30 cubic feet of fresh air per minute (1800 per hour), which amount must be introduced and thoroughly distributed without creating unpleasant draughts, or causing any two parts of the room to differ in temperature more than 2° Fahr., or the maximum temperature to exceed 70° Fahr." [The provision of 30 cu. ft. per minute for each person in a class-room is now (1909) required by law in several states.]

When the air enters at or near the floor, it is desirable that the velocity of inlet should not exceed 2 feet per second, which means larger sizes of register openings and flues than are usually obtainable, and much higher velocities of inlet than two feet per second are the rule in practice. The velocity of current into vent-flues can safely be as high as 6 or even 10 feet per second, without being disagreeably perceptible.

The entrance of fresh air into a room is coincident with, or dependent on, the removal of an equal amount of air from the room. The ordinary means of removal is the vertical vent-duct, rising to the top of the build-



ing. Sometimes reliance for the production of the current in this vent-duct is placed solely on the difference of temperature of the air in the room and that of the external atmosphere; sometimes a steam coil is placed within the flue near its bottom to heat the air within the duct; sometimes steam pipes (risers and returns) run up the duct performing the same functions; or steam jets within the flue, or exhaust fans, driven by steam or electric power, act directly as exhausters; sometimes the heating of the air in the flue is accomplished by gas-jets.

The draft of such a duct is caused by the difference of weight of the heated air in the duct, and of a column of equal height and cross-sectional area of the external air.

Let  $d$  = density, or weight in pounds, of a cubic foot of the external air.

Let  $d_1$  = density, or weight in pounds, of a cubic foot of the heated air within the duct.

Let  $h$  = vertical height, in feet, of the vent-duct.

$h(d - d_1)$  = the pressure, in pounds per square foot, with which the air is forced into and out of the vent-duct.

This pressure expressed in height of a column of air of density within the vent-duct is  $h(d - d_1) \div d$ .

Or, if  $t$  = absolute temperature of external air, and  $t_1$  = absolute temperature of the air in the vent-duct, then the pressure =  $h(t_1 - t) \div t$ .

The theoretical velocity, in feet per second, with which the air would travel through the vent-duct under this pressure is

$$v = \sqrt{\frac{2gh(t_1 - t)}{t}} = 8.02 \sqrt{\frac{h(t_1 - t)}{t}}$$

The actual velocity will be considerably less than this, on account of loss due to friction. This friction will vary with the form and cross-sectional area of the vent-duct and its connections, and with the degree of smoothness of its interior surface. On this account, as well as to prevent leakage of air through crevices in the wall, tin lining of vent-flues is desirable.

The loss by friction may be estimated at approximately 50%, and the actual velocity of the air as it flows through the vent-duct is

$$v = \frac{1}{2} \sqrt{2gh \frac{(t_1 - t)}{t}}, \text{ or, approximately, } v = 4 \sqrt{h \frac{(t_1 - t)}{t}}$$

If  $V$  = velocity of air in vent-duct, in feet per minute, and the external air be at 32° Fahr., since the absolute temperature on Fahrenheit scale equals thermometric temperature plus 459.4,

$$V = 240 \sqrt{h \frac{(t_1 - t)}{491.4}}$$

from which has been computed the following table:

**Quantity of Air, in Cubic Feet, Discharged per Minute through a Ventilating Duct, of which the Cross-sectional Area is One Square Foot (the External Temperature of Air being 32° Fahr.).**

Height of Vent-duct in feet.	Excess of Temperature of Air in Vent-duct above that of External Air.								
	5°	10°	15°	20°	25°	30°	50°	100°	150°
10.....	77	108	133	153	171	188	242	342	419
15.....	94	133	162	188	210	230	297	419	514
20.....	108	153	188	217	242	265	342	484	593
25.....	121	171	210	242	271	297	383	541	663
30.....	133	188	230	265	297	325	419	593	726
35.....	143	203	248	286	320	351	453	640	784
40.....	153	217	265	306	342	375	484	683	838
45.....	162	230	282	325	363	398	514	723	889
50.....	171	242	297	342	383	419	541	760	937

Multiplying the figures in preceding table by 60 gives the cubic feet of air discharged per hour per square foot of cross-section of vent-duct. Knowing the cross-sectional area of vent-ducts we can find the total discharge; or for a desired air-removal, we can proportion the cross-sectional area of vent-ducts required.

**Heating and Ventilating of Large Buildings.** (A. R. Wolff, *Jour. Frank. Inst.*, 1893.)—The transmission of heat from the interior to the exterior of a room or building, through the walls, ceilings, windows, etc., is calculated as follows:

$S$  = amount of transmitting surface in square feet;

$t$  = temperature F. inside,  $t_0$  = temperature outside;

$K$  = a coefficient representing, for various materials composing buildings, the loss by transmission per square foot of surface in British thermal units per hour, for each degree of difference of temperature on the two sides of the material;

$Q$  = total heat transmission =  $SK(t - t_0)$ .

This quantity of heat is also the amount that must be conveyed to the room in order to make good the loss by transmission, but it does not cover the additional heat to be conveyed on account of the change of air for purposes of ventilation. (See Wolff's coefficients below, page 688.)

These coefficients are to be increased respectively as follows: 10% when the exposure is a northerly one, and winds are to be counted on as important factors; 10% when the building is heated during the daytime only, and the location of the building is not an exposed one; 30% when the building is heated during the daytime only, and the location of the building is exposed; 50% when the building is heated during the winter months intermittently, with long intervals (say days or weeks) of non-heating.

The value of the radiating-surface is about as follows: Ordinary bronzed cast-iron radiating-surfaces, in American radiators (of Bundy or similar type), located in rooms, give out about 250 heat-units per hour for each square foot of surface, with ordinary steam-pressure, say 3 to 5 lbs, per sq. in., and about 0.6 this amount with ordinary hot-water heating.

Non-painted radiating-surfaces, of the ordinary "indirect" type (Climax or pin surfaces), give out about 400 heat-units per hour for each square foot of heating-surface, with ordinary steam-pressure, say 3 to 5 lbs. per sq. in.; and about 0.6 this amount with ordinary hot-water heating.

A person gives out about 400 heat-units per hour; an ordinary gas-burner, about 4800 heat-units per hour; an incandescent electric (16 candle-power) light, about 200 heat-units per hour.

The following example is given by Mr. Wolff to show the application of the formula and coefficients:

Lecture-room  $40 \times 60$  ft., 20 ft. high, 48,000 cubic feet, to be heated to  $69^\circ$  F.; exposures as follows: North wall,  $60 \times 20$  ft., with four windows, each  $14 \times 8$  feet, outside temperature  $0^\circ$  F. Room beyond west wall and room overhead heated to  $69^\circ$ , except a double skylight in ceiling,  $14 \times 24$  ft., exposed to the outside temperature of  $0^\circ$ . Store-room beyond east wall at  $36^\circ$ . Door  $6 \times 12$  ft. in wall. Corridor beyond south wall heated to  $59^\circ$ . Two doors,  $6 \times 12$ , in wall. Cellar below, temperature  $36^\circ$ .

If we assume that the lecture-room must be heated to  $69^\circ$  F. in the daytime when unoccupied, so as to be at this temperature when first persons arrive, there will be required, ventilation not being considered, and bronzed direct low-pressure steam-radiators being the heating media, about  $113,550 \div 250 = 455$  sq. ft. of radiating-surface.

If we assume that there are 160 persons in the lecture-room, and we provide 2500 cubic feet of fresh air per person per hour, we will supply  $160 \times 2500 = 400,000$  cubic feet of air per hour (*i.e.*, over eight changes of contents of room per hour).

To heat this air from  $0^\circ$  F. to  $69^\circ$  F. will require  $400,000 \times 0.01785 \times 69 = 492,660$  thermal units per hour (0.01785 being the product of the weight of a cubic foot, 0.075, by the specific heat of air, 0.238). Accordingly there must be provided  $492,660 \div 400 = 1232$  sq. ft. of indirect

surface, to heat the air required for ventilation, in zero weather. If the room were to be warmed entirely indirectly, that is, by the air supplied to room (including the heat to be conveyed to cover loss by transmission through walls, etc.), there would have to be conveyed to the fresh-air supply  $492,660 + 118,443 = 611,103$  heat-units. This would imply the provision of an amount of indirect heating-surface of the "Climax" type of  $611,103 \div 400 = 1527$  sq. ft., and the fresh air entering the room would have to be at a temperature of about  $86^\circ$  F., viz.,

$$69^\circ + \frac{118,413}{400,000 \times 0.01785}, \text{ or } 69 + 17 = 86^\circ \text{ F.}$$

The above calculations do not, however, take into account that 160 persons in the lecture-room give out  $160 \times 400 = 64,000$  thermal units per hour; and that, say, 50 electric lights give out  $50 \times 200 = 10,000$  thermal units per hour; or, say, 50 gaslights,  $50 \times 4800 = 240,000$  thermal units per hour. The presence of 160 people and the gaslighting would diminish considerably the amount of heat required. If the 50 gaslights give out 240,000 thermal units per hour, the air supplied for ventilation must enter considerably below  $69^\circ$  Fahr., or the room will be heated to an unbearably high temperature. If 400,000 cubic feet of fresh air per hour are supplied, and 240,000 thermal units per hour generated by the gas must be abstracted, it means that the air must, under these

conditions, enter  $\frac{240,000}{400,000 \times 0.01785} = \text{about } 34^\circ$  less than  $86^\circ$ , or at about  $52^\circ$  Fahr. Recent researches show that the increase of  $\text{CO}_2$  in air due to gas lighting is not detrimental to health.

The following table shows the calculation of heat transmission (some figures changed from the original):

$t-t_0$ (Fahr. degrees).	Kind of Transmitting Surface.	Thickness of Wall in inches.	Calculation of Area of Transmitting Surface.	Square feet of Surface.	$K (t-t_0)$ .	Thermal Units.
69°	Outside wall.....	36"	$63 \times 22 - 448$	938	10	9,380
69	Four windows (single).....		$4 \times 8 \times 14$	448	83	37,186
33	Inside wall (store-room).....	36"	$42 \times 22 - 72$	852	4	3,408
33	Door.....		$6 \times 12$	72	19	1,368
10	Inside wall (corridor).....	24"	$45 \times 22 - 72$	918	2	1,836
10	Door.....		$6 \times 12$	72	5	360
10	Inside wall (corridor).....	36"	$17 \times 22 - 72$	302	1	302
10	Door.....		$6 \times 12$	72	5	360
69	Roof.....		$32 \times 42 - 336$	1,008	10	10,080
69	Double skylight.....		$14 \times 24$	336	35	11,760
33	Floor.....		$62 \times 42$	2,604	4	10,416
	Supplementary allowance, north outside wall, 10%.....					86,454
	Supplementary allowance, north outside windows, 10%.....					938
						3,718
	Exposed location and intermittent day or night use, 30%.....					91,110
						27,333
	Total thermal units.....					118,443

**Comfortable Temperatures and Humidities.**—A. G. Woodman and J. F. Norton, in a work on Air, Water, and Food (1914), give, on the authority of Hill's Recent Advances in Physiology and Biochemistry, a "curve of comfort," practically a straight line, which runs from 20% relative humidity at  $87^\circ$  F. to 75% at  $55^\circ$  F. It approximates 40, 50 and 60% respectively at  $75^\circ$ ,  $70^\circ$  and  $65^\circ$  F, showing that to secure comfort as temperature rises, the humidity must be decreased. The most comfortable conditions for indoor workers are given at 40% humidity at  $68^\circ$  and 60% at  $64^\circ$  F.

**Carbon Dioxide Allowable in Factories.**—Haldane and Osborne (London, 1902) recommend that the  $\text{CO}_2$  in the air at the breathing



line in factories, and away from the immediate influence of special sources of contamination, such as persons or gas lights, should not rise during daylight, or after dark when electric lights only are used, beyond 12 volumes in 10,000 of air, and when gas or oil is used for lighting not over 20 volumes after dark.

A pamphlet issued by the National Commercial Gas Association (1914) states that the use of gas for interior lighting does not affect the atmosphere of interiors deleteriously.

**Heat Produced by Human Beings.**—According to Landry and Roseman, the average man produces every 24 hours per kilogram of body 32 to 38 calories when at rest, 35 to 45 when in easy action, and 50 to 70 when at hard work. Translating this into British thermal units per hour, and taking the weight of an average man at 140 lb., these figures are equivalent, approximately, to a man giving off 336 to 400 B. T. U. per hour when at rest, 368 to 473 when in easy action, and 525 to 735 when at hard work.

Atwater and Rosa, average of 13 experiments, found that a man gave off 2200 cal. per 24 hours at rest and 3400 at work, equivalent to 364 and 562 B. T. U. per hour, respectively.

**Standards of Ventilation.**—(C-E.A. Winslow, N. Y. State Commission on Ventilation, *Science*, April 30, 1915.) Pettenkoffer in 1863 showed that CO<sub>2</sub> in itself is without effect in the highest concentrations which it ever attains in occupied rooms. During the last fifteen years the researches of Flügge, Haldane, Hill, Benedict and others indicate that the effects experienced in a badly ventilated room are due to the heat and moisture produced by the bodies of the occupants rather than to CO<sub>2</sub> or other substances from the breath. Subjects immured in close chambers are not at all relieved by breathing pure outdoor air through a tube, but are relieved completely by keeping the chamber artificially cool, and to a considerable extent by the mere circulating of the air by an electric fan.

The experiments of the N. Y. State Commission show that the working of the circulatory and heat regulating machinery of the body was markedly influenced by a slight increase in room temperature, as from 68° to 75° with 50% relative humidity in both cases. Psychological tests failed to show that 86° and 80% relative humidity had any effect on the power to do mental work, but with physical work (lifting dumb bells and riding a stationary bicycle), when the subjects had a choice they accomplished 15% less work at 75°, and 37% less at 86°, than they did at 68°. As to the effect of stagnant breathed air contaminated so as to show from 20 to 60 parts CO<sub>2</sub> per 10,000, the results are entirely negative so far as mental and physical tests are concerned.

In practice, an unventilated room is an overheated room. Ventilation is just as essential to remove the heat produced by human bodies as it was once thought to be to remove the CO<sub>2</sub> produced by the lungs. The quantitative standards of air change established on the old chemical basis serve very well in the new, or heat change, basis. An average adult producing 400 B.T.U. per hour will require 2000 cubic feet of air per hour at 60° to prevent the temperature rising above 70°. An ordinary gas burner produces 300 B.T.U. per candle-power hour, and requires 1500 cubic feet of air per hour per candle power. In crowded auditoria every bit of the 2000 cubic feet of air per hour per person is needed, and in many industrial processes, where the heat from human beings is reinforced by friction and other sources, even more will be required.

Recent research has on the whole strengthened the arguments for ventilation. The thermometer is the first essential; a rise above 70° must be recognized as a sign of discomfort, of decreased efficiency and lowered vitality. The standard of 30 cubic feet of air per minute per capita remains as the amount necessary to supply if an occupied room is to be kept cool and fresh.

The question of humidity remains to be solved. A lack of humidity makes hot air feel cooler and cold air feel warmer. Extreme dryness, at high or moderate temperatures, is believed by many to be in itself harmful, but there is no solid experimental evidence on this point.

**Air Washing.**—(D. D. Kimball, N. Y. State Commission on Ventilation, *Science*, April 30, 1915.) An air washer consists of a sheet-metal

chamber in which the air is passed through a heavy mist and then through baffles or eliminator plates by which the entrained moisture is removed. The base of the washer is a tank into which the spray falls and from which it is drawn by a centrifugal pump. The pump forces the water through spray nozzles in the spray chamber of the washer. Manufacturers customarily guarantee the removal of 98% of the dust in the air. Practically all the larger particles are removed, but there is always a residue of fine dust which no washer will remove. When there is very little dust in the air, as after a heavy rain, the percentage of the remaining dust that can be removed is quite small. M. C. Whipple's tests showed that the dust removed varied from 64% to 7%.

The best results in artificial humidification have been obtained by means of the air washer. The degree of humidification is controlled by thermostatic devices. The air washer may also be used for air cooling. The evaporation in the spray chamber will lower the temperature to the extent of 75% or more of the difference between the wet and dry bulb temperatures, equivalent to a temperature reduction often amounting to 10 to 15 degrees. Unfortunately cooling by means of an air washer is expensive. Roughly, the cost of cooling 10 degrees equals the cost of heating 70 degrees.

**Contamination of Air.**—The following data are found in "The Air and Ventilation of Subways," by G. A. Soper (1908).

Carbon dioxide in air in streets of European cities, 3.01 to 5.02 parts in 10,000. Center of Paris annual average varied from 3.06 to 3.44 parts. Average of 309 analyses in New York, 3.67 parts.

An average adult inhales about 396 cubic inches per minute. Analysis of inspired air: O, 20.81; N, 79.15; CO<sub>2</sub>, 0.04. Expired air: O, 16.00; N, 79.59; CO<sub>2</sub>, 4.38. Air highly charged with CO<sub>2</sub> is not dangerous to breathe for a considerable time. CO<sub>2</sub> must be present to 40 times the amount present when the room begins to smell "stuffy" before it increases the rate of breathing. Neither does a decrease of 2 or 3 per cent in the oxygen produce any immediate effect. Long before the air becomes so vitiated as this other impurities from the lungs make the air extremely unpleasant.

The CO<sub>2</sub> in badly vitiated places seldom rises above 50 parts in 10,000.

The air becomes uncomfortably close and musty when CO<sub>2</sub> exceeds 8 parts in 10,000.

Amount of CO<sub>2</sub> exhaled by a man, average per hour: at rest, 16.11 grams, or 8198 cu. cm.; at work, 30.71 grams, or 15,628 cu. cm.

## STANDARD VALUES FOR USE IN CALCULATION OF HEATING AND VENTILATING PROBLEMS.

### Heating Value of Coal.

	Volatiles Matter in the Com- bustible, Per Cent.	Heating Value per lb. Combustible, B.T.U.	Aver- age.	Moisture, in Air-dried Coal, Per Cent.	Ash in Air-dried Coal, Per Cent.
Anthracite.....	3 to 7.5	14,700 to 14,900	14,800	0.5 to 1.0	10. to 18.
Semi-anthracite..	7.5 to 12.5	14,900 to 15,500	15,200	0.5 to 1.0	10. to 10.
Semi-bituminous.	12.5 to 25	15,500 to 16,000	15,750	0.5 to 1.0	5. to 10.
Bit. eastern.....	25 to 40	14,800 to 15,000	15,150	1. to 4.	5. to 15.
Bit western.....	35 to 50	13,500 to 14,800	14,150	4. to 14.	10. to 25.
Lignite.....	Over 50	11,000 to 13,500	12,250	10. to 18.	5. to 25.

*Average Heating Value of Air-Dried Coal.*—Anthracite, 12,600; semi-anthracite, 12,950; semi-bituminous, 14,450; bituminous eastern, 13,250; bituminous western, 10,400; lignite, 9,700.

Eastern bituminous coal is that of the Appalachian coal field extending from Pennsylvania and Ohio to Alabama. Western bituminous coal is that of the great coal fields west of Ohio.

*Steam Boiler Efficiency.*—The maximum efficiency obtainable with anthracite in low-pressure steam boilers, water heaters or hot-air furnaces is about 80 per cent, when the thickness of the coal bed and the draft are such as to cause enough air to be supplied to effect complete combustion of the carbon to CO<sub>2</sub>. With coals high in volatile matter the max-

imum efficiency is probably not over 70 per cent. Very much lower efficiencies than these figures are obtained when the air supply is either deficient or greatly in excess, or when the furnace is not adapted to burn the volatile matter in the coal. D. T. Randall, in tests made in 1908 for the U. S. Geological Survey, with house-heating boilers, obtained efficiencies ranging from 0.62 with coke, 0.61 with anthracite, and 0.58 with semi-bituminous, down to 0.39 with Illinois coal.

*Available Heating Value of the Coal.*—Using the figures given above as the average heating value of coal stored in a dry cellar, the following are the probable *maximum* values in B. T.U., of the heat available for furnishing steam or heating water or air, for the several efficiencies stated:

Anthracite.	Semi-An.	Semi-Bit.	Bit. East.	Bit. West.	Lignite.
Eff'y.....0.80	0.77	0.75	0.70	0.65	0.60
B.T.U...10,080	9,933	10,837	9,275	6,760	5,820

For average values in practice, about 10 per cent may be deducted from these figures. (It is possible that an efficiency higher than 80% may be obtained with anthracite in some forms of air-heating furnaces in which the escaping chimney gases are cooled, by contact with the cold air inlet pipes, to comparatively low temperatures.)

The value 10,000 B.T.U. is usually taken as the figure to be used in calculation for design of heating and ventilating apparatus. For coals with lower available heating values proper reductions must be made.

**Heat Transmission through Walls, Windows, etc., in B.T.U. per Sq. Ft. per Hour per Degree of Difference of Temperature.**

	Wolff. B.T.U.	Hauss. B.T.U.		Wolff. B.T.U.	Hauss. B.T.U.
<b>GLASS SURFACES.</b>			<b>FLOORS.</b>		
Vault light.....	1.42	.....	Joists with double floor.....	0.10	0.07
Single window.....	1.20	1.00	Concrete floor.....	0.31	.....
Double window.....	0.56	0.46	Fireproof construction, planked over.	0.124	.....
Single skylight.....	1.03	1.06	Wooden beam construction, planked over.....	0.083	.....
Double skylight.....	0.50	0.48	Concrete floor on brick arch.....	.....	0.22
<b>DOORS.</b>			Stone floor on arches	.....	0.20
Door.....	.....	0.40	Planks laid on earth.	.....	0.16
1-in. pine.....	0.40	.....	Planks laid on asphalt.....	.....	0.20
2-in. pine.....	0.28	.....	Arch with air space..	.....	0.09
<b>PARTITIONS.</b>			Stones laid on earth.	.....	0.08
Solid plaster,	.....	.....	<b>CEILINGS.</b>		
1 3/4 to 2 1/4 in.....	.....	0.60	Joists with single floor.....	.....	0.10
2 1/2 to 3 1/4 in.....	.....	0.48	Arches with air space	.....	0.14
Fireproof.....	0.30	.....			
2-in. pine board.....	0.28	.....			

**BRICK WALLS.**

Thickness, In.	Wolff.	Hauss.	Average B.T.U.*	Thickness, In.	Wolff.	Hauss.	Average, B.T.U.*
4	0.66	.....	0.537	25	.....	0.18	0.188
4 3/4	.....	0.48	0.508	28	0.18	.....	0.172
8	0.45	.....	0.397	30	.....	0.16	0.163
10	.....	0.34	0.351	32	0.16	.....	0.154
12	0.33	.....	0.313	35	.....	0.13	0.143
15	.....	0.26	0.272	36	0.145	.....	0.140
16	0.27	.....	0.260	40	0.13	0.12	0.128
20	0.23	0.22	0.222	45	.....	0.11	0.116
24	0.20	.....	0.194				

\* The average figure for brick walls was obtained by plotting the reciprocals of Wolff's and Hauss's figures and drawing a straight line



## SOLID SANDSTONE WALLS. (HAUSS.)

Thickness, in. . . . .	12	16	20	24	28	32	36	40	44	48
B.T.U. . . . . . . . . . .	0.45	0.39	0.35	0.32	0.29	0.26	0.24	0.22	0.20	0.19

For limestone walls, add 10 per cent.

**Allowances for Exposures.** — Wolff adds 25% for north and west exposures, 15% for east, and 5% for south exposures, also 10% additional for reheating, and 10% to the transmission through floor and ceilings. The allowance for reheating Mr. Wolff explains as follows in a letter to the author, Mar. 10, 1905. The allowance is made on the basis that the apparatus will not be run continuously; in other words, that it will not be run at all, or only lightly, overnight. The rooms will cool off below the required temperature of 70°, and to be able to heat up quickly in the morning an allowance of 10% is made to the transmission figures to meet this condition. Hauss makes allowances as follows: 5% for rooms with unusual exposure; 10% where exposures are north, east, northeast, northwest and west; 31/3% where the height of ceiling is more than 13 ft.; 62/3% where it is more than 15 ft.; 10% where it is more than 18 ft. For rooms heated daily, but where heating is interrupted at night, add

$$A = 0.0025 [(N - 1) W_1] \div Z.$$

For rooms not heated daily, add  $B = [0.1 W (8 - Z)] \div Z$ .

In these formulas  $W_1 =$  B.T.U. transmitted per hour by exposed surfaces;  $W =$  total B.T.U. necessary, including that for ventilation or changes of air;  $N =$  time from cessation of heating to time of starting fire again, hours;  $Z =$  time necessary after fire is started until required room temperature is reached, hours.

**Allowance for Exposure and for Leakage.** — In calculations of the quantity of heat required by ordinary residences, the formula total heat  $= (T_1 - T_0) \left( \frac{W}{4} + G + \frac{nC}{56} \right)$  is commonly used.  $T_1 =$  temp. of room,  $T_0 =$  outside temp.,  $W =$  exposed wall surface less window surface,  $G =$  glass surface,  $C =$  cubic contents of room,  $n =$  number of changes of air per hour. The factor  $n$  is usually assumed arbitrarily or guessed at; some writers take its value at 1, others 1 for the rooms, 2 for the halls, etc.; others object to the use of  $C$  as a factor, saying that the allowance for exposure and leakage should be made proportional to the exposed wall and glass surface since it is on these surfaces that the leakage occurs, and omitting the term  $nC/56$  they multiply the remainder of the expression by a factor for exposure,  $c = 1.1$  to 1.3, depending on the direction of the exposure. To show what different results may be obtained by the use of the two methods, the following table is calculated, applying both to six rooms of widely differing sizes. Two sides of each room, north and east, are exposed.  $T_1 = 70$ ;  $T_0 = 0$ ;  $G = 1/5 (W + G)$ .

Room.	Size, ft.	$C =$ cu. ft.	Total Wall, $(W + G)$ sq. ft.	Glass, $G$ .	Ratio, $(C \div W + G)$ .	$H = 70(W/4 + G)$ .	$70 C/56$ .	$0.2 H$ .	$0.3 H$ .
A	10×10×10	1,000	20×10= 200	40	5	5,600	1,250	1,120	1,680
B	10×20×10	2,000	30×10= 300	60	62/3	8,400	2,500	1,680	2,520
C	20×20×12	4,800	40×12= 480	96	10	13,440	6,000	2,688	4,032
D	20×40×14	11,200	60×14= 840	168	171/3	23,520	14,000	4,704	7,056
E	40×40×15	24,000	80×15= 1200	240	20	33,600	30,000	6,720	10,080
F	40×80×16	51,200	120×16= 1920	384	262/3	54,460	64,000	10,892	16,338

The figures in the column headed  $H = 70 (W/4 + G)$  represent the heat transmitted through the walls, those in the column  $70 C/56$  are the

between them, representing the average heat resistances, and then taking the reciprocals of the resistances for different thicknesses. The resistance corresponds to the straight line formula  $R = 0.12 + 0.165 t$ , where  $t =$  thickness in inches. (Hauss's figures are from a paper by Chas. F. Hauss, of Antwerp, Belgium, in *Trans. A. S. H. V. E.*, 1904.)

heat required for one change of air per hour;  $0.2 H$  is the heat corresponding to an allowance of 20% for exposure and leakage, and  $0.3 H$  corresponds to an allowance of 30%. For the small rooms A and B the difference between  $70 C/56$  and  $0.2 H$  or  $0.3 H$  is not of great importance, but it becomes very important in the largest rooms; in room *F* the difference between  $70 C/56$  and  $0.2 H$  is nearly equal to the total heat transmitted through the walls, indicating that the use of the cubic contents as a factor in calculations of large rooms is likely to lead to great errors. This is due to the fact that the ratio  $C \div (W + G)$  varies greatly with different sizes of rooms.

With forced ventilation, the quantity of heat needed depends chiefly upon the number of persons to be provided for. Assuming 2000 cu. ft. per hour per person, heated from  $0^\circ$  to  $70^\circ$ , and 1, 2 and 4 persons per 100 sq. ft. of floor surface, the heat required for the air is as follows:

Room.....	A	B	C	D	E	F
1 person per 100 sq. ft.	2,500	5,000	10,000	20,000	40,000	80,000
2 persons per 100 sq. ft.	5,000	10,000	20,000	40,000	80,000	160,000
4 persons per 100 sq. ft.	10,000	20,000	40,000	80,000	160,000	320,000
Ratio of last line to $H..$	1.8	2.4	3.0	3.4	4.8	5.9

**Heating by Hot-air Furnaces.** — A simple formula for calculating the total heat in British Thermal Units required for heating and ventilating

by any system is  $H = \left[ c \left( G + \frac{W}{4} \right) + \frac{nC}{56} \right] (T_1 - T_0)$ . (See notation above.)

The formula is derived as follows: The heat transmitted through 1 sq. ft. of single glass window is approximately 1 B.T.U. per hour per degree of difference of temperature, and that through 1 sq. ft. of 16-in. brick wall about 0.25 B.T.U. (For more accurate calculations figures taken from the tables (p. 688) should be used.) The specific heat of air is taken at 0.238, and the weight of 1 cu. ft. air at  $70^\circ$  F. at 0.075 lb. per cu. ft. The product of these figures is 0.01785, and its reciprocal is 56.

For a difference  $T_1 - T_0 = 70^\circ$ ,  $0.01785 \times 70 = 1.2495$ , we may, therefore, write the formula

$$\text{Total heat} = 70 \left[ c \left( G + \frac{W}{4} \right) \right] + 1.25 A$$

= heat conducted through walls + heat exhausted in ventilation.

$A$  is the cubic feet of air (measured at  $70^\circ$ ) supplied to and exhausted from the building. This formula neglects the heat conducted through the roof, for which a proper addition should be made.

There are two methods of heating by hot-air furnaces; one in which all the air for both heating and ventilation is taken from outdoors and exhausted from the building, and the other in which only the air for ventilation is taken from outdoors, and additional air is recirculated through the furnace from the building itself. The first method is an exceedingly wasteful one in cold weather. By the second it is possible to heat a building with no greater expenditure of fuel than is required for steam or hot-water heating.

**EXAMPLE.** — Required the amount of heat and the quantity of air to be circulated by the two methods named for a building which has  $G = 400$ ,  $W = 2000$ ,  $C = 16,000$ ,  $n = 2$ ,  $T_1 = 70^\circ$ ,  $T_0 = 0^\circ$ ,  $T_2$ , the temperature at which the air leaves the furnace, being taken for three cases as  $100^\circ$ ,  $120^\circ$ , and  $140^\circ$ . Assume  $c$ , the coefficient for exposure, including heat lost through roof, = 1.2. When only enough air for ventilation is taken into and exhausted from the building, the formula gives

$$70 \times 1.2 (500 + 400) + 1.25 \times 32,000 = 115,600 \text{ B.T.U.} = 75,600 \text{ for heat} + 40,000 \text{ for ventilation.}$$

Suppose all the air required for heating is taken from outdoors at  $0^\circ$  F., and all exhausted at  $70^\circ$ , the quantity,  $A$ , then, instead of being 32,000 cu. ft., has to be calculated as follows:

$$\begin{aligned} \text{Total heat} &= c \left( G + \frac{W}{4} \right) (T_1 - T_0) + A \times 0.01785 \times (T_1 - T_0) \\ &= 0.01785 A (T_2 - T_0). \end{aligned}$$

Heat supplied by furnace = heat for conduction + heat for ventilation

from which we find  $A = c \left( G + \frac{W}{4} \right) (T_1 - T_0) \div 0.01785 (T_2 - T_1)$   
 $= 75,600 \div 0.01785 (T_2 - 70^\circ)$ .

For the value of $T_2$ .....	$T_2=100$	$T_2=120$	$T_2=140$
$A =$ cu. ft.....	141,117	84,706	60,504
Heat lost by exhausting this air at $70^\circ$ ...	176,396	105,882	75,630
Adding 75,600 loss by walls gives total...	251,996	181,482	152,230
Excess above 115,600 actually required for heating and ventilating, % .....	118.0	57.0	31.7

**British Thermal Units Absorbed in Heating 1 Cu. Ft. of Air, or given up in cooling it.** — (The air is measured at  $70^\circ$  F.)

$T_1 - T_2 =$

$10^\circ$	20	30	40	50	56	60	70	80	90	100	110	120	126	130	140
0.18	0.36	0.54	0.71	0.89	1.	1.07	1.25	1.43	1.61	1.78	1.96	2.14	2.25	2.32	2.5

**Area in Square Inches of Pipe required to Deliver 100 Cu. Ft. of Air per Minute, at Different Velocities.** — The air is measured at the temperature of the air in the pipe.

Velocity per second.....	2	3	4	5	6	7	8	9	10
Area, sq. in.....	120	80	60	48	40	34.3	30	26.7	24

The quantity of air required for ventilation or heating should be figured at a standard temperature, say  $70^\circ$  F., but when warmer air is to be delivered into the room through pipes, the area of the pipes should be calculated on the basis of the temperature of the warm air, and not on that of the room.

EXAMPLE. — A room requires to be supplied with 1000 cu. ft. per min. at  $70^\circ$  F. for ventilation, but the air is also used for heating and is delivered into the room at  $120^\circ$  F. Required, the area of the delivery pipe, if the velocity of the heated air in the pipe is 6 ft. per second.

From the table of volumes, given on the next page, 1000 cu. ft. at  $70^\circ = 1094$  cu. ft. at  $120^\circ$ . From the above table of areas, at 6 ft. velocity 40 sq. in. area is required for 100 cu. ft., therefore 1094 cu. ft. will require  $10.94 \times 40 = 437.6$  sq. in. or about 3 sq. ft.

**Carrying Capacity of Air Pipes.**

Diam.	Area in Sq. In.	Area, Sq. Ft.	Velocity, Feet per Second.					
			3	4	5	6	7	8
			Cu. Ft. per Min.					
5	19.63	.1364	24.6	32.7	40.9	49.1	57.3	65.5
6	28.27	.1963	35.3	47.1	58.9	70.7	82.4	94.2
7	38.48	.2673	48.1	64.2	80.2	96.2	112.	128.
8	50.27	.3491	62.8	83.8	105.	126.	147.	168.
9	63.62	.4418	80.0	106.	133.	159.	186.	212.
10	78.54	.5454	98.2	131.	164.	196.	229.	262.
11	95.03	.6600	119.	158.	198.	238.	277.	317.
12	113.1	.7854	141.	188.	236.	283.	330.	377.
13	132.7	.9218	166.	221.	277.	332.	387.	442.
14	153.9	1.069	192.	257.	321.	385.	449.	513.
15	176.7	1.227	221.	294.	368.	442.	515.	589.
11.3	100.	0.694	125.	167.	208.	250.	292.	333.
13.6	144.	1.	180.	240.	300.	360.	420.	480.

The figures in the table give the carrying capacity of pipes in cu. ft. of air at the temperature of the air flowing in the pipes. To reduce the figures to cu. ft. at a standard temperature (such as  $70^\circ$  F.) divide by the ratio of the volume per cu. ft. of the air in the pipe to that of the air of the standard temperature, as in the following table:



**Volume of Air at Different Temperatures.**  
(Atmospheric pressure.)

Fahr. Deg.	Cu. Ft. in 1 lb.	Comparative Volume.	Fahr. Deg.	Cu. Ft. in 1 lb.	Comparative Volume.	Fahr. Deg.	Cu. Ft. in 1 lb.	Comparative Volume
0	11.583	0.867	90	13.845	1.038	160	15.603	1.169
32	12.387	0.928	100	14.096	1.056	170	15.854	1.188
40	12.586	0.943	110	14.346	1.075	180	16.106	1.207
50	12.840	0.962	120	14.596	1.094	190	16.357	1.226
62	13.141	0.985	130	14.848	1.113	200	16.608	1.245
70	13.342	1.000	140	15.100	1.132	210	16.860	1.264
80	13.593	1.019	150	15.351	1.151	212	16.910	1.267

**Sizes of Air Pipes Used in Furnace Heating.** (W. G. Snow, *Eng. News*, April 12, 1900.)

W'th. of Room Ft.	Length of Room, Ft.										
	10	12	14	16	18	20	22	24	26	28	30
	Diameter of Pipe, Ins.										
8....	8, 7	8, 7	9, 8	9, 8	.....	.....	.....	.....	.....	.....	.....
10....	8, 7	9, 8	9, 8	10, 8	10, 8	10, 9	.....	.....	.....	.....	.....
12....	.....	9, 8	10, 8	10, 8	10, 9	11, 9	11, 9	12, 10	.....	.....	.....
14....	.....	.....	10, 8	10, 9	11, 9	11, 9	12, 10	12, 10	13, 10	13, 10	.....
16....	.....	.....	.....	11, 9	11, 9	12, 10	12, 10	13, 10	13, 10	13, 11	13, 11
18....	.....	.....	.....	.....	12, 10	12, 10	13, 11	13, 11	13, 11	14, 12	14, 12
20....	.....	.....	.....	.....	.....	13, 11	13, 11	13, 11	14, 12	14, 12	14, 12

The first figure in each column shows the size of pipe for the first floor and the second figure the size for the second floor. Temperature at register, 140°; room, 70°; outside, 0°. Rooms 8 to 16 ft. in width assumed to be 9 ft. high; 18 to 20 ft. width, 10 ft. high. When first-floor pipes are longer than 15 ft. use one size larger than that stated. For third floor, use one size smaller than for second floor. For rooms with three exposures, increase the area of pipe in proportion to the exposure.

The table was calculated on the following basis:

The loss of heat is calculated by first reducing the total exposure to equivalent glass surface. This is done by adding to the actual glass surface one-quarter the area of exposed wood and plaster or brick walls and  $\frac{1}{20}$  the area of floor or ceiling. Ten per cent is added where the exposure is severe. The window area assumed is 20% of the entire exposure of the room.

Multiply the equivalent of glass surface by 85. The product will be the total loss of heat by transmission per hour.

Assuming the temperature of the entering air to be 140° and that of the room to be 70°, the air escaping at approximately the latter temperature will carry away one-half the heat brought in. The other half, corresponding to the drop in temperature from 140° to 70°, is lost by transmission. With outside temperature zero, each cubic foot of air at 140° brings into the room 2.2 heat units. Since one-half of this, or 1.1 heat units, can be utilized to offset the loss by transmission, to ascertain the volume of air per hour at 140° required to heat a given room, divide the loss of heat by transmission by 1.1. This result divided by 60 gives the number of cubic feet per minute. In calculating the table, maximum velocities of 280 and 400 ft. were used for pipes leading to the first and second floors respectively. The size of the smaller pipes was based on lower velocities, according to their size, to allow for their greater resistance and loss of temperature.

**Furnace-Heating with Forced Air Supply.** (*The Metal Worker*, April 8, 1905.) — Tests were made of a Kelsey furnace with the air supply furnished by a 48-in. Sturtevant disk fan driven by a 5 H.P. electric motor. A connection was made from the air intake, between the fan and the furnace, to the ash pit so that the rate of combustion could be regulated independently of the chimney-draft condition. The furnace had 4.91 sq. ft. of grate surface and 238 sq. ft. of heating surface. The volume of air was determined by anemometer readings at 24 points in a cross-section of a rectangular intake of 11.88 sq. ft. area. The principal results obtained in two tests of 8 hours each are as follows:

Av. temp. of the cold air . . . . .	39°	58°
Per cent humidity of the cold air . . . . .	71	56
Av. temp. of the warm air . . . . .	135°	152°
Air delivered to heater, cu. ft. per hour . . .	250,896	249,195
B.T.U. absorbed by the dry air per hour . . .	451,872	421,496
B.T.U. absorbed by the vapor per hour . . .	2,016	3,102
Avge. no. of pounds of coal burned per hour	36	33.5
B.T.U. given by the coal per hour . . . . .	529,200	492,450
Per cent efficiency of the furnace . . . . .	85.7	86.2

**Grate Surface and Rate of Burning Coal.**

In steam boilers for power plants, which are constantly attended by firemen, coal is generally burned at between 10 and 30 lbs. per sq. ft. of grate per hour. In small boilers, house heaters and furnaces, which even in the coldest weather are supplied with fresh coal only once in several hours, it is necessary to burn the coal at very much slower rates. Taking a cubic foot of coal as weighing 60 lbs., in a bed 12 inches deep, and 1 sq. ft. of grate area, it would be one-half burned away in 7½ hours at a rate of burning of 4 lbs. per sq. ft. of grate per hour. This figure, 4 lbs., is commonly taken in designing grate surface for house-heating boilers and furnaces. Using this figure we have the following as the rated capacity of different areas of grate surface.

**Rated Capacity of Furnaces and Boilers for House Heating.**

Diam. of Round Grate.	Area in —		Coal-burning Capacity per Hour.	Capacity, B.T.U. per Hour.	Equiv. lbs. Steam Evap. 212° per Hour.	Equiv. lbs. Air per Hour Heated 100°.	Equiv. cu. ft. Air at 70° Heated 100°.
	sq. in.	sq. ft.					
ins.	sq. in.	sq. ft.	lbs.	(a)	(b)	(c)	(d)
12	113.1	.785	3.142	31,420	32.5	1,320	17,610
14	153.9	1.069	4.276	42,760	44.3	1,797	23,970
16	201.1	1.396	5.585	55,850	57.8	2,347	31,300
18	254.5	1.767	7.069	70,690	73.2	2,970	39,620
20	314.2	2.182	8.728	87,280	90.4	3,667	48,920
22	380.1	2.640	10.560	105,600	109.4	4,437	59,190
24	452.4	3.142	12.566	125,660	130.1	5,280	70,430
26	530.9	3.687	14.748	147,480	152.7	6,197	82,670
28	615.8	4.276	17.104	171,040	177.1	7,187	95,870
30	706.9	4.909	19.636	196,360	203.3	8,260	110,190
32	804.2	5.585	22.340	223,400	231.3	9,387	125,220
34	907.9	6.305	25.220	252,200	261.2	10,597	141,360
36	1017.9	7.069	28.276	282,760	292.8	11,881	158,490

Figures in column (b) = (a) ÷ 965.7.

Figures in column (c) = (a) ÷ (100 × 0.238).

Figures in column (d) = (c) × 13.34.

Latent heat of steam at 212° = 965.7 B.T.U. [new steam tables give 970.4].

Specific heat of air = 0.238.

Note that the figures in the last three columns are all based on the rate of combustion of 4 lbs. of coal per sq. ft. of grate per hour, which is taken as the standard for house heating. For heating schoolhouses and other large buildings where the furnace is fed with coal more frequently a

much higher actual capacity may be obtained from the grate surface named. A committee of the Am. Soc. H. and V. Engrs. in 1909 says:

The grate surface to be provided depends on the rate of combustion, and this in turn depends on the attendance and draft, and on the size of the boiler. Small boilers are usually adapted for intermittent attention and a slow rate of combustion. The larger the boiler, the more attention is given to it, and the more heating surface is provided per square foot of grate. The following rates of combustion are common for internally fired heating boilers:

Sq. ft. of grate . . . . .	4 to 8	10 to 18	20 to 30
Lbs. coal per sq. ft. grate per hr. not over	4	6	10

**Capacity of 1 sq. ft. and of 100 sq. in. of Grate Surface, for Steam, Hot-water, or Furnace Heating.**

(Based on burning 4 lbs. of coal per sq. ft. of grate per hour and 10,000 B.T.U. available heating value of 1 lb. of coal.)

1 sq. ft. grate equals	100 sq. ins. grate equals	
4	2.775	lbs. of coal per hour.
40,000	27,750	B.T.U. per hour.
41.25	28.61	lbs. of steam evap. from and at 212° per hr.
156.5	108.7	sq. ft. of steam radiating surface = B.T.U. ÷ 255.6*.
261.4	181.5	sq. ft. of hot-water radiating surface = B.T.U. ÷ 153 †.
22,420.	15,570.	cu. ft. of air (measured at 70° F.) per hour heated 100°.

\* Steam temperature 212°, room temperature 70°, radiator coefficient, that is the B.T.U. transmitted per sq. ft. of surface per hour per degree of difference of temperature, 1.8.

† Water temperature 160°, room temperature 70°, radiator coefficient 1.7.

For any other rate of combustion than 4 lbs., multiply the figures in the table by that rate and divide by 4.

**STEAM-HEATING.**

**The Rating of House-heating Boilers.**

(W. Kent, *Trans. A. S. H. V. E.*, 1909.)

The rating of a steam-boiler for house-heating may be based upon one or more of several data: 1, square feet of grate-surface; 2, square feet of heating-surface; 3, coal-burning capacity; 4, steam-making capacity; 5, square feet of steam-radiating-surface, including mains, that it will supply. In establishing such a rating the following considerations should be taken into account:

1. One sq. ft. of cast-iron radiator surface will give off about 250 B.T.U. per hour under ordinary conditions of temperature of steam 212°, and temperature of room 70°.

2. One pound of good anthracite or semi-bituminous coal under the best conditions of air-supply, in a boiler properly proportioned, will transmit about 10,000 B.T.U. to the boiler.

3. In order to obtain this economical result from the coal the boilers should be driven at a rate not greatly exceeding 2 lbs. of water evaporated from and at 212° per sq. ft. of heating-surface per hour, corresponding to a heat transmission of  $2 \times 970 = 1940$ , or, say, approximately 2000 B.T.U. per hour per sq. ft. of heating-surface.

4. A satisfactory boiler or furnace for house-heating should not require coal to be fed oftener than once in 8 hours; this requires a rate of burning of only 3 to 5 pounds of coal per sq. ft. of grate per hour.

5. For commercial and constructive reasons, it is not convenient to establish a fixed ratio of heating- to grate-surface for all sizes of boilers. The grate-surface is limited by the available area in which it may be placed, but on a given grate more heating-surface may be piled in one form of boiler than in another, and in boilers of one general form one boiler may be built higher than another, thus obtaining a greater amount of heating-surface.



6. The rate of burning coal and the ratio of heating- to grate-surface both being variable, the coal-burning rate and the ratio may be so related to each other as to establish condition 3, viz., a rate of evaporation of 2 lbs. of water from and at 212° per sq. ft. of heating-surface per hour.

These general considerations lead to the following calculations:

1 lb. of coal, 10,000 B.T.U. utilized in the boiler, will supply 10,000 ÷ 250 = 40 sq. ft. radiating-surface, and will require 10,000 ÷ 2000 = 5 sq. ft. boiler heating-surface. 1 sq. ft. of boiler-surface will supply 2000 ÷ 250 or 40 ÷ 5 = 8 sq. ft. radiating-surface.

	Low Boiler.	Medium.	High Boiler.
1 sq. ft. of grate should burn....	3	4	5 lb. coal per hour.
1 sq. ft. of grate should develop.	30,000	40,000	50,000 B.T.U. per hour.
1 sq. ft. of grate will require.....	15	20	25 sq. ft. heating-surf.
1 sq. ft. of grate will supply.....	120	160	200 sq. ft. radiating-sur.
Type of boiler, depending on ratio heating- ÷ grate-surface.	A.	B.	C.

TABLE OF RATINGS.

Type and No.	Sq. Ft. Grate.	Sq. Ft. Heat.- surf.	Coal Burned per Hour, lbs.	Water Evap. per Hour, lbs.	Rad.- surf., Sq. Ft.	Type and No.	Sq. Ft. Grate.	Sq. Ft. Heat.- surf.	Coal Burned per Hour, lbs.	Water Evap. per Hour, lbs.	Rad.- surf., Sq. Ft.
A 1...	1	15	3	30	120	B 8...	8	160	32	320	1,280
A 2...	2	30	6	60	240	C 6...	6	150	30	300	1,200
A 3...	3	45	9	90	360	C 7...	7	175	35	350	1,400
A 4...	4	60	12	120	480	C 8...	8	200	40	400	1,600
A 5...	5	75	15	150	600	C 10...	10	250	50	500	2,000
B 4...	4	80	16	160	640	C 12...	12	300	60	600	2,400
B 5...	5	100	20	200	800	C 14...	14	350	70	700	2,800
B 6...	6	120	24	240	960	C 16...	16	400	80	800	3,200
B 7...	7	140	28	280	1,120						

The table is based on the utilization in the boiler of 10,000 B.T.U. per pound of good coal. For poorer coal the same figures will hold good except the pounds coal burned per hour, which should be increased in the ratio of the B.T.U. of the good to that of the poor coal. Thus for coal from which 8000 B.T.U. can be utilized the coal burned per hour will be 25 per cent greater.

For comparison with the above table the following figures are taken and calculated from the catalogue of a prominent maker of cast-iron boilers:

Height.	G Grate.	H Heating-surface.	R Radiating-surface.	H/G	R/G	R/H	B.T.U. per Hour = R × 250	B.T.U. H	Coal per Hour per sq. ft. Grate *
Low.....	{ 2.1	45	210	21.5	100	4.7	52,500	1,167	2.5
	{ 4.7	90	600	19.1	128	6.7	150,000	1,667	3.2
Medium..	{ 4.2	103	600	24.5	143	5.8	150,000	1,456	3.6
	{ 8.2	195	1,500	23.8	183	7.7	375,000	1,923	4.6
High.....	{ 6.7	210	1,200	31.3	179	5.7	300,000	1,476	4.5
	{ 14.7	420	3,300	28.6	225	7.9	825,000	1,964	5.6

\* Equals B.T.U. per hour ÷ 10,000 G.

## TESTING CAST-IRON HOUSE-HEATING BOILERS.

The testing of the evaporating power and the economy of small-sized boilers is more difficult than the testing of large steam-boilers for the reason that the small quantity of coal burned in a day makes it impossible to procure a uniform condition of the coal on the grate throughout the test, and large errors are apt to be made in the calculation on account of the difference of condition at the beginning and end of a test. The following is suggested as a method of test which will avoid these errors.

(a) Measure the grate-surface and weigh out an amount of coal equal to 30, 40, or 50 lbs. per sq. ft. of grate, according to the type A, B, or C, or the ratio of heating- to grate-surface.

(b) Disconnect the steam-pipe, so that the steam may be wasted at atmospheric pressure. Fill the boiler with cold water to a marked level, and take the weight of this water and its temperature.

(c) Start a brisk fire with plenty of wood, so as to cause the coal to ignite rapidly; feed the coal as needed, and gradually increase the thickness of the bed of coal as it burns brightly on top, getting the fire-pot full as the last of the coal is fired. Then burn away all the coal until it ceases to make steam, when the test may be considered as at an end.

(d) Record the temperature of the gases of combustion in the flue every half-hour.

(e) Periodically, as needed, feed cold water, which has been weighed, to bring the water level to the original mark. Record the time and the weight.

## CALCULATIONS.

Total water fed to the boiler, including original cold water, pounds $\times$ (212° - original cold-water temperature) = .....	B.T.U.
Water apparently evaporated, pounds $\times$ 970 = .....	B.T.U.

Add correction for increased bulk of hot water:

Original water, pounds $\times \frac{(62.3 - 59.8)}{62.3} \times 970 =$ .....	B.T.U.
Total.....	B.T.U.

Divide by 970 to obtain equivalent water evaporation from and at 212° F.

Divide by the number of pounds of coal to obtain equivalent water per pound of coal.

The last result may be considerably less than 10 pounds on account of imperfect combustion at the beginning of the test, excessive air-supply when the coal bed is thin in the latter half of the test, and loss by radiation, but the results will be fairly comparable with results from other boilers of the same size and run under the same conditions. The records of water fed and of temperature of gases should be plotted, with time as the base, for comparison with other tests.

**Proportions of House-heating Boilers.** — A committee of the Am. Soc. Heating and Ventilating Engineers, reporting in 1909 on the method of rating small house-heating boilers, shows the following ratings, in square feet of radiating surface supplied by certain boilers of nearly the same nominal capacity, as given in makers' catalogues.

Boiler.....	A.	B.	C.	D.	E.	F.
Rated capacity.....	800	800	775	750	750	750
Square inches of grate.....	616	740	648	528	630	648
Ratio of grate to 100 sq. ft. of capacity	77	92.5	83.6	70.4	84	86.2
Estimated rate of combustion.....	5.1	4.2	4.65	5.63	4.4	4.5

The figures in the last line are lbs. of coal per sq. ft. of grate surface per hour, and are based on the assumptions of 10,000 B.T.U. utilized per lb. of coal and 270 B.T.U. transmitted by each sq. ft. of radiating surface per hour.

"The question of heating surface in a boiler seems to be an unknown quantity, and inquiry among the manufacturers does not produce much information on the subject."

Following is the list of sizes and ratings of the "Manhattan" sectional steam boiler. The figures for sq. ft. of grate surface and for the ratio of heating to grate surface (approx.) have been computed from the sizes given in the catalogue (1909).

Number of Sections.	Square feet of Direct Radiation Boiler will Supply	Size of Grate.		Square Feet of Surface in Boiler.	Ratio of Htg. to Grate Surface.	Number of Sections.	Square feet of Direct Radiation Boiler will Supply.	Size of Grate.		Square Feet of Surface in Boiler.	Ratio of Htg. to Grate Surface.
		ins.	sq. ft.					ins.	sq. ft.		
4	450	18×19	2.37	68	29	10	2250	24×63	10.5	212	20
5	600	18×25	3.75	84	23	6	2200	36×36	9	256	28
6	750	18×31	3.87	100	26	7	2700	36×43	11.74	298	26
7	900	18×37	4.65	116	25	8	3200	36×50	13.33	340	26
8	1050	18×43	5.37	132	25	9	3700	36×57	14.25	382	26
5	1000	24×30	5	111	22	10	4200	36×64	16	424	26
6	1250	24×36	6	128	21	11	4700	36×71	17.5	466	27
7	1500	24×43	7.16	149	21	12	5200	36×78	19.5	508	26
8	1750	24×50	8.33	170	20	13	5700	36×84	21	550	26
9	2000	24×57	9.5	191	20	14	6200	36×90	22.5	592	26

It appears from this list that there are three sets of proportions, corresponding to the three widths of grate surface. The average ratio of heating to grate surface in the three sets is respectively 25.0, 20.7, and 25.8; the rated sq. ft. of radiating surface per sq. ft. of grate is 185, 208, and 259, and the sq. ft. of radiating surface per sq. ft. of boiler heating surface is 7.4, 10.1, and 9.8. Taking 10,000 B.T.U. utilized per lb. of coal, and 250 B.T.U. emitted per sq. ft. of radiating surface per hour, the rate of combustion required to supply the radiating surface is respectively 4.62, 5.22, and 6.40 lbs. per sq. ft. of grate per hour.

**Coefficient of Heat Transmission in Direct Radiation.** — The value of *K*, or the B.T.U. transmitted per sq. ft. of radiating surface per hour per degree of difference of temperature between the steam (or hot water) and the air in the room, is commonly taken at 1.8 in steam heating, with a temperature difference of about 142°, and 1.6 in hot-water heating, with a temperature difference averaging 80°. Its value as found by test varies with the conditions; thus the total heat transmitted is not directly proportional to the temperature difference, but increases at a faster rate; single pipes exposed on all sides transmit more heat than pipes in a group; low radiators more than high ones; radiators exposed to currents of cool air more than those in relatively quiet air; radiators with a free circulation of steam throughout more than those that are partly filled with water or air, etc. The total range of the value of *K*, for ordinary conditions of practice, is probably between 1.5 and 2.0 for steam-heating with a temperature difference of 140°, averaging 1.8, and between 1.2 and 1.7, averaging 1.6, for hot-water heating, with a temperature difference of 80°.

C. F. Hauss, *Trans. A. S. H. V. E.*, 1904, gives as a basis for calculation, for a room heated to 70° with steam at 1½ lbs. gauge pressure (temperature difference 146° F.) 1 sq. ft. of single column radiator gives off 300 B.T.U. per hour; 2-column, 275; 3-column, 250; 4-column, 225.

**Value of *K* in Cast-iron Direct Radiators.** (J. R. Allen, *Trans. A. S. H. V. E.*, 1908.)  $T_s$  = temp. of steam;  $T_1$  = temp. of room.

	$T_s - T_1 = 110$	120	130	140	150	160
2-col. rad. ....	1.71	1.745	1.76	1.82	1.855	1.895
3-col. rad. ....	1.65	1.695	1.745	1.79	1.835	1.885
$T_s - T_1 = 170$	170	180	200	220	240	260
2-col. rad. ....	1.93	1.965	2.04	2.11	2.185	2.265
3-col. rad. ....	1.93	1.98	2.075	2.165	2.260	2.36



**B.T.U. Transmitted per Hour per Sq. Ft. of Heating Surface in Indirect Radiators.** (W. S. Munroe, *Eng. Rec.*, Nov. 18, 1899.)

		Cu. ft. of air per hour per sq. ft. of surface.								
		100	200	300	400	500	600	700	800	900
		B.T.U. per hour per sq. ft. of heating surface.								
"Gold Pin" radiator	(a)...	200	325	450	560	670	780	870	950	1030
	(b)...	300	550	760	950	1130	1300			
"Whittier"	(b)...	250	400	520	620	710				

		B.T.U. per hr. per sq. ft. per deg. diff. of temp.*								
Gold Pin (a).....		1.3	2.2	3.0	3.7	4.5	5.2	5.8	6.3	6.9
Gold Pin (b).....		2.0	3.7	5.1	6.3	7.7	8.7			
Whittier (b).....		1.7	2.7	3.5	4.1	4.7				

Temperature difference between steam and entering air, (a) 150; (b) 215.

\* Between steam and entering air.

**Short Rules for Computing Radiating-Surfaces.** — In the early days of steam-heating, when little was known about "British Thermal Units," it was customary to estimate the amount of radiating-surface by dividing the cubic contents of the room to be heated by a certain factor supposed to be derived from "experience." Two of these rules are as follows:

One square foot of surface will heat from 40 to 100 cu. ft. of space to 75° in — 10° latitudes. This range is intended to meet conditions of exposed or corner rooms of buildings, and those less so, as intermediate ones of a block. As a general rule, 1 sq. ft. of surface will heat 70 cu. ft. of air in outer or front rooms and 100 cu. ft. in inner rooms. In large stores in cities, with buildings on each side, 1 to 100 is ample. The following are approximate proportions:

One square foot radiating-surface will heat:

	In Dwellings, Schoolrooms, Offices, etc.	In Hall, Stores, Lofts, Factories, etc.	In Churches, Large Auditoriums, etc.
By direct radiation....	60 to 80 ft.	75 to 100 ft.	150 to 200 ft.
By indirect radiation..	40 to 50 ft.	50 to 70 ft.	100 to 140 ft.

Isolated buildings exposed to prevailing north or west winds should have a generous addition made to the heating-surface on their exposed sides.

1 sq. ft. of boiler-surface will supply from 7 to 10 sq. ft. of radiating-surface, depending upon the size of boiler and the efficiency of its surface, as well as that of the radiating-surface. Small boilers for house use should be much larger proportionately than large plants. Each horse-power of boiler will supply from 240 to 360 ft. of 1-in. steam-pipe, or 80 to 120 sq. ft. of radiating-surface. Under ordinary conditions 1 horse-power will heat, approximately, in —

Brick dwellings, in blocks, as in cities.....	15,000 to 20,000 cu. ft.
Brick stores, in blocks.....	10,000 " 15,000 "
Brick dwellings, exposed all round.....	10,000 " 15,000 "
Brick mills, shops, factories, etc.....	7,000 " 10,000 "
Wooden dwellings, exposed.....	7,000 " 10,000 "
Foundries and wooden shops.....	6,000 " 10,000 "
Exhibition buildings, largely glass, etc.....	4,000 " 15,000 "

Such "rules of thumb," as they are called, are generally supplanted by the modern "heat-unit" methods.

**Carrying Capacity of Pipes in Low-Pressure Steam Heating.** (W. Kent, *Trans. A. S. H. V. E.*, 1907.) — The following table is based on an assumed drop of 1 pound pressure per 1000 feet, not because that is the drop which should always be used — in fact the writer believes that in large installations a far greater drop is permissible — but because it gives a basis upon which the flow for any other drop may be calculated.

merely by multiplying the figures in the tables by the square root of the assigned drop. The formula from which the tables are calculated is the well known one,  $W = 60 \times c \sqrt{\frac{w (p_1 - p_2) d^5}{L}}$  in which  $W$  = weight of steam in lbs. per hour;  $w$  = weight of steam in pounds per cubic foot, at the entering pressure,  $p_1$ ;  $p_2$  the pressure at the end of the pipe;  $d$  the actual diameter of standard wrought-iron pipe in inches, and  $L$  the length in feet. The coefficients  $c$  are derived from Babcock's formula (see page 618) which is believed to be as accurate as any that has been derived from the very few recorded experiments on steam.

Nominal diam. of pipe.....	1/2	3/4	1	1 1/4	1 1/2	2	2 1/2	3	3 1/2
Value of $c$ .....	33.4	37.5	41.3	45.8	48.4	52.5	55.5	59.0	61.3
Nominal diam. of pipe.....	4	4 1/2	5	6	7	8	9	10	12
Value of $c$ .....	63.2	64.8	66.5	68.7	70.7	72.2	73.4	74.5	76.3

**Flow of Steam in Pipes for a Drop of 1 lb. per 1000 Ft. Length.**  
(Pounds per Hour.)

Nominal Diam. of Pipe, in.	Actual Internal Diam. d., in.	$p_1 = 0.3$	$p_1 = 1.3$	$p_1 = 2.3$	$p_1 = 3.3$	$p_1 = 4.3$	$p_1 = 5.3$	$p_1 = 6.3$	$p_1 = 8.3$	$p_1 = 10.3$
		$w = .03732$	$w = .04042$	$w = .04277$	$w = .04512$	$w = .04746$	$w = .04980$	$w = .05213$	$w = .05676$	$w = .0614$
1	1.049	17.1	17.8	18.3	18.8	19.2	19.7	20.2	21.0	21.9
1 1/4	1.380	37.6	39.1	40.2	41.3	42.4	43.4	44.4	46.3	48.2
1 1/2	1.610	58.4	60.7	62.5	64.1	65.8	67.4	68.9	71.9	74.8
2	2.067	118.2	123.0	126.6	130.0	133.3	136.6	139.7	145.8	151.6
2 1/2	2.469	194.9	202.8	208.7	214.3	219.7	225.1	230.3	240.3	250.0
3	3.068	356.6	371.0	381.8	392.0	402.1	411.9	421.4	439.7	457.3
3 1/2	3.548	532.7	554.5	570.5	585.8	600.8	615.4	629.8	681.5	683.8
4	4.026	753.6	784.2	807.0	828.6	849.6	870.6	890.4	929.4	966.6
4 1/2	4.506	1025.	1066.	1096.	1126.	1154.	1184.	1210.	1262.	1315.
5	5.047	1395.	1451.	1494.	1534.	1573.	1611.	1649.	1720.	1789.
6	6.065	2281.	2374.	2443.	2509.	2573.	2635.	2696.	2813.	2926.
7	7.023	3387.	3525.	3628.	3725.	3820.	3913.	4003.	4177.	4345.
8	7.981	4776.	4970.	5114.	5250.	5385.	5518.	5644.	5889.	6123.
9	8.941	6429.	6693.	6885.	7070.	7250.	7430.	7604.	7934.	8251.
10	10.020	8676.	9030.	9294.	9545.	9785.	10025.	10259.	10702.	11123.
11	11.000	11106.	11556.	11892.	12210.	12522.	12828.	13128.	13698.	14244.
12	12.000	13950.	14520.	14940.	15342.	15732.	16116.	16488.	17202.	17892.

$p_1$  = initial pressure, by gauge, lb. per sq. in.  $w$  = density, lb. per cu. ft.

For any other drop of pressure per 1000 feet length, multiply the figures in the table by the square root of that drop, or by the factor below.

Drop lb. per 1000 ft....	1/4	1/2	2	3	4	6	8	10	15	20
Factor .....	0.5	0.71	1.41	1.73	2.0	2.45	2.83	3.16	3.87	4.47

In all cases the judgment of the engineer must be used in the assumption of the drop to be allowed. For small distributing pipes it will generally be desirable to assume a drop of not more than one pound per 1000 feet to insure that each single radiator shall always have an ample supply for the worst conditions, and in that case the size of piping given in the table up to two inches may be used; but for main pipes supplying totals of more than 500 square feet, greater drops may be allowed.

### Proportioning Pipes to Radiating Surface.

FIGURES USED IN CALCULATION OF RADIATING SURFACE.

$P$  = Pressure by gauge, lbs. per sq. in.

0.    0.3    1.3    2.3    3.3    4.3    5.3    6.3    8.3    10.3

$L$  = latent heat of evaporation, B.T.U. per lb.\*

965.7 965.0 962.6 960.4 958.3 956.3 954.4 952.6 949.1 945.8

Temperature Fahrenheit,  $T_1$ .

212.    213.    216.3    219.4    222.4    225.2    227.9    230.5    235.4    240.0

$T_2 = T_1 - 70^\circ$ , difference of temperature.

142.    143.    146.3    149.4    152.4    155.2    157.9    160.5    165.4    170.0

$H_1 = T_2 \times 1.8$  = heat transmission per sq. ft. radiating surface, B.T.U. per hour.

255.6    257.4    263.3    268.9    274.3    279.2    284.2    288.9    297.7    306.0

$H_1 \div L$  = steam condensed per sq. ft. radiating surface, lbs. per hour.

0.2647    0.267    0.274    0.280    0.286    0.292    0.298    0.303    0.314    0.324

Reciprocal of above = radiating surface per lb. of steam condensed per hour.

3.78    3.75    3.65    3.57    3.50    3.42    3.36    3.30    3.18    3.09

The last three lines of figures are based on the empirical constant 1.8 for the average British thermal units transmitted per square foot of radiating surface per hour per degree of difference of temperature. This figure is approximately correct for several forms of both cast-iron radiators and pipe coils, not over 30 inches high and not over two pipes in width.

### RADIATING SURFACE SUPPLIED BY DIFFERENT SIZES OF PIPE.

On basis of steam in pipe at 0.3 and 10.3 lbs. gauge pressure, temperature of room  $70^\circ$ , heat transmitted per square foot radiating surface 257.4 and 306 British thermal units per hour, and drop of pressure in pipe at the rate of 1 lb. per 1000 feet length; = pounds of steam per hour in the table on the preceding page, 1st column,  $\times 3.75$ , and last column,  $\times 3.09$ .

Size of Pipe.	Radiating Surface, Sq. Ft.		Size of Pipe,	Radiating Surface, Sq. Ft.		Size of Pipe.	Radiating Surface, Sq. Ft.	
	0.3 lb.	10.3 lb.		In.	0.3 lb.		10.3 lb.	In.
1/2	16	16	2 1/2	734	769	6	7,541	7,901
3/4	36	38	3	1,296	1,357	7	11,010	11,535
1	71	75	3 1/2	1,895	1,986	8	15,307	16,040
1 1/4	150	157	4	2,630	2,755	9	20,482	21,451
1 1/2	230	241	4 1/2	3,520	3,686	10	27,427	28,718
2	453	475	5	4,695	4,919	12	43,312	45,423

For greater drops than 1 lb. per 1000 ft. length of pipe, multiply the figures by the square root of the drop.

\* The latest steam tables (1909) give somewhat higher figures, but the difference is unimportant here.



Sizes of Steam Pipes in Heating Plants. — G. W. Stanton, in *Heating and Ventilating Mag.*, April, 1908, gives tables for proportioning pipes to radiating surface, from which the following table is condensed:

Supply Pipe. Ins.	Radiating Surface Sq. Ft.				Returns.		Drips.		Connections.		
	A	B	C	D	B	C <sub>1</sub> D	A	B <sub>1</sub> C <sub>1</sub> D	A <sub>1</sub>	A <sub>2</sub> B <sub>1</sub> C <sub>1</sub>	B <sub>2</sub> C <sub>2</sub>
1	24	60	36	60	1	1	3/4	3/4	1 1/4	1	1
1 1/4	60	100	72	120	1	1	3/4	3/4	1 1/2	1 1/4	1
1 1/2	125	200	120	240	1 1/4	1 1/4	1	1	2	1 1/2	1 1/4
2	250	400	280	480	1 1/2	1 1/2	1 1/4	1	2 1/2	2	1 1/2
2 1/2	600	700	528	880	2	2	1 1/4	1 1/4	3	.....	.....
3	800	1,000	900	1,500	2	2 1/2	1 1/2	1 1/4	3 1/2	.....	.....
3 1/2	1,000	1,600	1,320	2,200	2 1/2	2 1/2	1 1/2	1 1/4	4	.....	.....
4	1,600	2,300	1,920	3,200	2 1/2	3	1 1/2	1 1/4	4 1/2	.....	.....
4 1/2	1,900	3,200	2,760	4,600	2 1/2	3					
5	2,300	4,100	3,720	6,200	3	3 1/2					
6	4,100	6,500	6,000	10,000	3	3 1/2					
7	6,500	9,600	9,000	15,000	3 1/2	4					
8	9,600	13,600	12,800	21,600	4	4					
9	13,600	.....	17,800	30,000	.....	4 1/2					
10	.....	.....	23,200	39,000	.....	5					
12	.....	.....	37,000	62,000	.....	6					
14	.....	.....	54,000	92,000	.....	7					
16	.....	.....	76,000	130,000	.....	8					

Supply mains and risers are of the same size. Riser connections on the two-pipe system to be the same size as the riser.

A. For single-pipe steam-heating system 0 to 5 lb. pressure. A<sub>1</sub>, riser connections. A<sub>2</sub>, radiator connections.

B. Two-pipe system 0 to 5 lb. pressure; B<sub>1</sub>, C<sub>1</sub>, radiator connections, supply; B<sub>2</sub>, C<sub>2</sub>, radiator connections, return.

C, D. Two-pipe system 2 and 5 lbs. respectively, mains and risers not over 100 ft. length. For other lengths, multiply the given radiating surface by factors, as below:

Length, ft....	200	300	400	500	600	700	800	900	1000
Factor.....	0.71	0.58	0.5	0.45	0.41	0.38	0.35	0.33	0.32

Mr. Stanton says: Theoretically both supply and return mains could be much smaller, but in practice it has been found that while smaller pipes can be used if a job is properly and carefully figured and proportioned and installed, for work as ordinarily installed it is far safer to use the sizes that have been tried and proven. By using the sizes given a job will circulate throughout with 1 lb. steam pressure at the boiler.

**Resistance of Fittings.** — Where the pipe supplying the radiation contains a large number of fittings, or other conditions make such a refinement necessary, it is advisable to add to the actual distance of the radiation from the source of supply a distance equivalent to the resistance offered by the fittings, and by the entrance to the radiator, the value of which, expressed in feet of pipe of the same diameter as the fitting, will be found in the accompanying table. *Power*, Dec., 1907.

FEET OF PIPE TO BE ADDED FOR EACH FITTING.

Size Pipe.	1	1 1/4	1 1/2	2	2 1/2	3	3 1/2	4	4 1/2	5	6	7	8	9	10
Elbows...	3	4	5	7	8	10	12	13	15	17	20	23	27	30	33
Globe V..	7	8	10	13	17	20	23	27	30	33	40	47	53	60	67
Entrance	5	6	8	10	12	15	18	20	23	25	30	35	40	45	50

**Overhead Steam-pipes.** (A. R. Wolff, *Stevens Indicator*, 1887.) — When the overhead system of steam-heating is employed, in which system direct radiating-pipes, usually  $1\frac{1}{4}$  in. in diam., are placed in rows overhead, suspended upon horizontal racks, the pipes running horizontally, and side by side, around the whole interior of the building, from 2 to 3 ft. from the walls, and from 2 to 4 ft. from the ceiling, the amount of  $1\frac{1}{4}$ -in. pipe required, according to Mr. C. J. H. Woodbury, for heating mills (for which use this system is deservedly much in vogue), is about 1 ft. in length for every 90 cu. ft. of space. Of course a great range of difference exists, due to the special character of the operating machinery in the mill, both in respect to the amount of air circulated by the machinery, and also the aid to warming the room by the friction of the journals.

**Removal of Air from Radiators. Vacuum Systems.** — In order that a steam radiator may work at its highest capacity it is necessary that it be neither water-bound nor air-bound. Proper drainage must therefore be provided, and also means for continuously, or frequently, removing air from the system, such as automatic air-valves on each radiator, an air-pump or an air-ejector on a chamber or receiver into which the returns are carried, or separate air-pipes connecting each radiator with a vacuum chamber. When a vacuum system is used, especially with a high vacuum, much lower temperatures than usual may be used in the radiators, which is an advantage in moderate weather.

#### Steam-consumption in Car-heating.

C., M. & ST. PAUL RAILWAY TESTS. (*Engineering*, June 27, 1890, p. 764.)

Outside Temperature.	Inside Temperature.	Water of Condensation per Car per Hour.
40	70	70 lbs.
30	70	85
10	70	100

**Heating a Greenhouse by Steam.** — Wm. J. Baldwin answers a question in the *American Machinist* as below: With five pounds steam-pressure, how many square feet or inches of heating-surface is necessary to heat 100 square feet of glass on the roof, ends, and sides of a greenhouse in order to maintain a night heat of  $55^{\circ}$  to  $65^{\circ}$ , while the thermometer outside ranges at from  $15^{\circ}$  to  $20^{\circ}$  below zero; also, what boiler-surface is necessary? Which is the best for the purpose to use — 2" pipe or  $1\frac{1}{4}$ " pipe?

*Ans.* — Reliable authorities agree that 1.25 to 1.50 cubic feet of air in an enclosed space will be cooled per minute per sq. ft. of glass as many degrees as the internal temperature of the house exceeds that of the air outside. Between  $+65^{\circ}$  and  $-20^{\circ}$  there will be a difference of  $85^{\circ}$ , or, say, one cubic foot of air cooled  $127.5^{\circ}$  F. for each sq. ft. of glass for the most extreme condition mentioned. Multiply this by the number of square feet of glass and by 60, and we have the number of cubic feet of air cooled  $1^{\circ}$  per hour within the building or house. Divide the number thus found by 48, and it gives the units of heat required, approximately. Divide again by 953, and it will give the number of pounds of steam that must be condensed from a pressure and temperature of five pounds above atmosphere to water at the same temperature in an hour to maintain the heat. Each square foot of surface of pipe will condense from  $\frac{1}{4}$  to nearly  $\frac{1}{2}$  lb. of steam per hour, according as the coils are exposed or well or poorly arranged, for which an average of  $\frac{1}{3}$  lb. may be taken. According to this, it will require 3 sq. ft. of pipe surface per lb. of steam to be condensed. Proportion the heating-surface of the boiler to have about one fifth the actual radiating-surface, if you wish to keep steam over night, and proportion the grate to burn not more than six pounds of coal per sq. ft. of grate per hour. With very slow combustion, such as takes place in base-burning boilers, the grate might be proportioned for four to five pounds of coal per hour. It is cheaper to make coils of  $1\frac{1}{4}$ " pipe than of 2", and there is nothing to be gained by using 2" pipe unless the coils are very long. The pipes in a greenhouse should be under or in front of the benches, with every chance for a good circulation

of air. "Header" coils are better than "return-bend" coils for this purpose.

Mr. Baldwin's rule may be given the following form: Let  $H$  = heat-units transferred per hour,  $T$  = temperature inside the greenhouse,  $t$  = temperature outside,  $S$  = sq. ft. of glass surface; then  $H = 1.5 S (T - t) \times 60 \div 48 = 1.875 S (T - t)$ . Mr. Wolff's coefficient  $K$  for single skylights gives  $H = 1.03 S (T - t)$ , and for single windows,  $1.20 S (T - t)$ .

**Heating a Greenhouse by Hot Water.** — W. M. Mackay, of the Richardson & Boynton Co., in a lecture before the Master Plumbers' Association, N. Y., 1889, says: I find that while greenhouses were formerly heated by 4-inch and 3-inch cast-iron pipe, on account of the large body of water which they contained, and the supposition that they gave better satisfaction and a more even temperature, florists of long experience who have tried 4-inch and 3-inch cast-iron pipe, and also 2-inch wrought-iron pipe for a number of years in heating their greenhouses by hot water, and who have also tried steam-heat, tell me that they get better satisfaction, greater economy, and are able to maintain a more even temperature with 2-inch wrought-iron pipe and hot water than by any other system they have used. They attribute this result principally to the fact that this size pipe contains less water and on this account the heat can be raised and lowered quicker than by any other arrangement of pipes, and a more uniform temperature maintained than by steam or any other system.

### HOT-WATER HEATING.

The following notes are from the catalogue of the Nason Mfg. Co.:

There are two distinct forms or modifications of hot-water apparatus, depending upon the temperature of the water.

In the first or open-tank system the water is never above  $212^{\circ}$  temperature, and rarely above  $200^{\circ}$ . This method always gives satisfaction where the surface is sufficiently liberal, but in making it so its cost is considerably greater than that for a steam-heating apparatus.

In the second method, sometimes called (erroneously) high-pressure hot-water heating, or the closed-system apparatus, the tank is closed. If it is provided with a safety-valve set at 10 lbs. it is practically as safe as the open-tank system.

**Law of Velocity of Flow.** — The motive power of the circulation in a hot-water apparatus is the difference between the specific gravities of the water in the ascending and the descending pipes. This effective pressure is very small, and is equal to about one grain for each foot in height for each degree difference between the pipes; thus, with a height of 1 ft. "up" pipe, and a difference between the temperatures of the up and down pipes of  $8^{\circ}$ , the difference in their specific gravities is equal to 8.16 grains (0.001166 lb.) on each square inch of the section of return-pipe, and the velocity of the circulation is proportioned to these differences in temperature and height.

Main flow-pipes from the heater, from which branches may be taken, are to be preferred to the practice of taking off nearly as many pipes from the heater as there are radiators to supply.

It is not necessary that the main flow and return pipes should equal in capacity that of all their branches. The hottest water will seek the highest level, while gravity will cause an even distribution of the heated water if the surface is properly proportioned.

It is good practice to reduce the size of the vertical mains as they ascend, say at the rate of one size for each floor.

As with steam, so with hot water, the pipes must be unconfined to allow for expansion of the pipes consequent on having their temperatures increased.

An expansion tank is required to keep the apparatus filled with water, which latter expands  $\frac{1}{24}$  of its bulk on being heated from  $40^{\circ}$  to  $212^{\circ}$ , and the cistern must have capacity to hold certainly this increased bulk. It is recommended that the supply cistern be placed on level with or above the highest pipes of the apparatus, in order to receive the air which collects in the mains and radiators, and capable of holding at least  $\frac{1}{20}$  of the water in the entire apparatus.

**Arrangement of Mains for Hot-water Heating.** (W. M. Mackay, Lecture before Master Plumbers' Assoc., N. Y., 1889). — There are two different systems of mains in general use, either of which, if properly



placed, will give good satisfaction. One is the taking of a single large-flow main from the heater to supply all the radiators on the several floors, with a corresponding return main of the same size. The other is the taking of a number of 2-inch wrought-iron mains from the heater, with the same number of return mains of the same size, branching off to the several radiators or coils with 1 $\frac{1}{4}$ -inch or 1-inch pipe, according to the size of the radiator or coil. A 2-inch main will supply three 1 $\frac{1}{4}$ -inch or four 1-inch branches, and these branches should be taken from the top of the horizontal main with a nipple and elbow, except in special cases where it is found necessary to retard the flow of water to the near radiator, for the purpose of assisting the circulation in the far radiator; in this case the branch is taken from the side of the horizontal main. The flow and return mains are usually run side by side, suspended from the basement ceiling, and should have a gradual ascent from the heater to the radiators of at least 1 inch in 10 feet. It is customary, and an advantage where 2-inch mains are used, to reduce the size of the main at every point where a branch is taken off.

The single or large main system is best adapted for large buildings; but there is a limit as to size of main which it is not wise to go beyond — generally 6-inch, except in special cases.

The proper area of cold-air pipe necessary for 100 square feet of indirect radiation in hot-water heating is 75 square inches, while the hot-air pipe should have at least 100 square inches of area. There should be a damper in the cold-air pipe for the purpose of controlling the amount of air admitted to the radiator, depending on the severity of the weather.

**Sizes of Pipe for Hot-water Heating.** — A theoretical calculation of the required size of pipe in hot-water heating may be made in the following manner. Having given the amount of heat, in B.T.U. to be emitted by a radiator per minute, assume the temperatures of the water entering and leaving, say 160° and 140°. Dividing the B.T.U. by the difference in temperatures gives the number of pounds of water to be circulated, and this divided by the weight of water per cubic foot gives the number of cubic feet per minute. The motive force to move this water, per square inch of the area of the riser, is the difference in weight per cu. ft. of water at the two temperatures, divided by 144, and multiplied by  $H$ , the height of the riser, or for  $T_1 = 160$  and  $T_2 = 140$ ,  $(61.37 - 60.98) \div 144 = 0.00271$  lb. per sq. in. for each foot of the riser. Dividing 144 by 61.37 gives 2.34, the ft. head of water corresponding to 1 lb. per sq. in., and  $0.00271 \times 2.34 = 0.0066$  ft. head, or if the riser is 20 ft. high,  $20 \times 0.0066 = 0.132$  ft. head, which is the motive force to move the water over the whole length of the circuit, overcoming the friction of the riser, the return pipe, the radiator and its connections. If the circuit has a resistance equal to that of a 50-ft. pipe, then  $50 \div 0.132 = 380$  is the ratio of length of pipe to the head, which ratio is to be taken with the number of cubic feet to be circulated, and by means of formulæ for flow of water, such as Darcy's, or hydraulic tables, the diameter of pipe required to convey the given quantity of water with this ratio of length of pipe to head is found. This tedious calculation is made more complicated by the fact that estimates have to be made of the frictional resistance of the radiator and its connections, elbows, valves, etc., so that in practice it is almost never used, and "rules of thumb" and tables derived from experience are used instead.

On this subject a committee of the Am. Soc. Heating and Ventilating Engineers reported in 1909 as follows:

The amount of water of a certain temperature required per hour by radiation may be determined by the following formula:

$$\frac{R \times X}{20 \times 60.8 \times 60} = \text{cu. ft. of water per minute.}$$

$R$  = square feet of radiation;  $X$  = B.T.U. given off per hour by 1 sq. ft. of radiation (150 for direct and 230 for indirect) with water at 170°. Twenty is the drop in temperature in degrees between the water entering the radiation and that leaving it; 60.8 is the weight of a cubic foot of water at 170 degrees; 60 is to reduce the result from hours to minutes.

The average sizes of mains, as used by seven prominent engineers in regular practice for 1800 square feet of radiation, are given below:

2-pipe open-tank system, 100 ft. mains, 5-in. pipe = 26.6 ft. per min.  
 1-pipe open-tank system, 100 ft. mains, 6-in. pipe = 18.4 ft. per min.  
 Overhead open-tank system, 100 ft. mains, 4-in. pipe = 41.8 ft. per min.  
 Overhead open-tank system, 100 ft. mains, 3-in. pipe = 72.1 ft. per min.

For 1200 sq. ft. indirect radiation with separate main, 100 ft. long, direct from boiler, open system, the bottom of the radiator being 1 ft. above the top of the boiler — 5-in. pipe = 22.4 ft. per min.

## CAPACITY OF MAINS 100 FT. LONG.

Expressed in the number of square feet of hot-water radiating surface they will supply, the radiators being placed in rooms at 70° F., and 20° drop assumed.

Diameter of Pipes, Ins.	Two-Pipe up Feed Open Tank.	One-Pipe up Feed Open Tank.	Overhead Open Tank.	Overhead Closed Tank.	Two-Pipe Open Tank.
1 1/4.....	75	45	127	250	48
1 1/2.....	107	65	181	335	69
2.....	200	121	339	667	129
2 1/2.....	314	190	533	1,060	202
3.....	540	328	916	1,800	348
3 1/2.....	780	474	1,334	2,600	502
4.....	1,060	645	1,800	3,350	684
5.....	1,860	1,130	3,150	6,200	1,200
6.....	2,960	1,800	5,000	9,800	1,910
7.....	4,280	2,700	7,200	13,900	2,760
8.....	5,850	3,500	9,900	19,500	3,778

The figures are for direct radiation except the last column which is for indirect, 12 in. above boiler.

## CAPACITY OF RISERS.

Expressed in the number of sq. ft. of direct hot-water radiating surface they will supply, the radiators being placed in rooms at 70° F., and 20° drop assumed. The figures in the last column are for the closed-tank overhead system the others are for the open-tank system.

Diameter of Riser, Inches.	1st Floor.	2d Floor.	3d Floor.	4th Floor.	Drop Risers, not exceeding 4 floors.
1.....	33	46	57	64	48
1 1/4.....	71	104	124	142	112
1 1/2.....	100	140	175	200	160
2.....	187	262	325	375	300
2 1/2.....	292	410	492	580	471
3.....	500	755	875	1,000	810

All horizontal branches from mains to risers or from risers to radiators, more than 10 ft. long (unless within 15 ft. of the boiler), should be increased one size over that indicated for risers in the above table.

For indirect radiation, the amount of surface may be computed as follows:

Temperature of the air entering the room, 110° =  $T$ .

Average temperature of the air passing through the radiator, 55°.

Temperature of the air leaving the room, 70° =  $t$ .

Velocity of the air passing through the radiator, 240 ft. per min.

Cubic feet of air to be conveyed per hour, =  $C = (H \times 55) \div (T - t)$ .

$H$  = exposure loss in B.T.U. per hour.

Heat necessary to raise this air to the entering temperature from 0° F.,  $T \times C + 55 = H$ .

The amount of radiation is found by dividing the total heat by the emission of heat by indirect radiators per square foot per hour per degree difference in temperature. This varies with the velocity, as shown below:

Velocity, ft. per min....	174	246	300	342	378	400	428	450	474	492
B.T.U.....	1.70	2.00	2.22	2.38	2.52	2.60	2.67	2.72	2.76	2.80

The difference between 170 degrees (average temperature of the water in the radiator) and 55 degrees (average temperature of the air in the radiator) being 115, the emission at 240 ft. per min. is 2. per degree difference or 230 B.T.U.

Ordinarily the amount of indirect radiation required is computed by adding a percentage to the amount of direct radiation [computed by the usual rules], and an addition of 50% has been found sufficient in many cases; but in buildings where a standard of ventilation is to be maintained, the formula mentioned seems more likely to give satisfactory results. Free area between the sections of radiation to allow passage of the required volume of air at the assumed velocity must be maintained. The cold-air supply duct, on account of less frictional resistance, may ordinarily have 80% of the area between the radiator sections. The hot-air flues may safely be proportioned for the following air velocities per minute: First floor, 200 feet; second floor, 300 feet; third floor, 400 feet.

#### PIPE SIZES FOR HOT-WATER HEATING.

Based on 20° difference in temperature between flow and return water. (C. L. Hubbard, *The Engineer* July 1, 1902.)

Diam. of Pipe.	Length of Run.										
	1	1 1/4	1 1/2	2	2 1/2	3	3 1/2	4	5	6	7
Square Feet of Direct Radiating Surface.											
100	30	60	100	200	350	550	850	1,200	.....	.....	.....
200	.....	50	75	150	250	400	600	850	1,400	.....	.....
300	.....	.....	50	125	200	300	450	700	1,150	.....	.....
400	.....	.....	.....	100	175	275	400	600	1,000	1,600	.....
500	.....	.....	.....	75	150	250	350	525	900	1,400	.....
600	.....	.....	.....	.....	125	225	325	475	850	1,300	.....
700	.....	.....	.....	.....	.....	200	300	450	775	1,200	1,700
800	.....	.....	.....	.....	.....	175	250	400	725	1,150	1,600
1000	.....	.....	.....	.....	.....	150	225	350	650	1,000	1,500
Square Feet of Indirect Radiation.											
100	15	30	50	100	200	300	400	600	1,000	.....	.....
200	.....	20	30	70	120	200	300	400	700	.....	.....
Square Feet of Direct Radiating Surface.											
1st story	30	60	100	200	350	550	850	.....	.....	.....	.....
2d "	55	90	140	275	275	.....	.....	.....	.....	.....	.....
3d "	65	110	165	375	.....	.....	.....	.....	.....	.....	.....
4th "	75	125	185	425	.....	.....	.....	.....	.....	.....	.....
5th "	85	140	210	500	.....	.....	.....	.....	.....	.....	.....
6th "	95	160	240	.....	.....	.....	.....	.....	.....	.....	.....

The size of pipe required to supply any given amount of hot-water radiating surface depends upon (1) The square feet of radiation; (2) its elevation above the boiler; (3) the difference in temperature of the water in the supply and return pipes; (4) the length of the pipe connecting the radiator with the boiler.

In estimating the length of a pipe the number of bends and valves must be taken into account. It is customary to consider an elbow as equivalent to a pipe 60 diameters in length, and a return bend to 120 diameters. A globe valve may be taken about the same as an elbow.

A series of articles on The Determination of the Sizes of Pipe for Hot Water Heating, by F. E. Geisecke, is printed in *Domestic Engineering*, beginning in May, 1909.



**Sizes of Flow and Return Pipes Approximately Proportioned to Surface of Direct Radiators for Gravity Hot-Water Heating.**  
(G. W. Stanton, *Heat. & Ventg. Mag.*, April, 1908.)

Size of Mains.	Mains.		Branches of Mains.			
	In Cellar or Basement.	On One or More Floors. Average.	First Floor 10'-15'.	Second Floor 15'-25'.	Third Floor 25'-35'.	Fourth or Fifth Floor 35'-45'.
	Square Feet of Radiating Surface.					
3/4				40	45	50
1			50	75	80	85
1 1/4	100	135	110	120	135	150
1 1/2	135	220	180	195	210	230
2	225	350	290	320	350	370
2 1/2	320	460	400	490	525	550
3	500	675	620	650	690	730
3 1/2	650	850	820	870	920	970
4	850	1,100	1,050	1,120	1,185	1,250
4 1/2	1,050	1,350	1,325	1,400	1,485	1,560
5	1,350	1,700				
6	2,900	3,600				
7	3,900	4,800				
8	5,000	6,200				
9	6,300	7,700				
10	7,900	9,800				
11	9,500	11,800				
12	11,400	14,000				

Note.—The heights of the several floors are taken as:  
1st. 10 to 15 ft.; 2d. 15 to 25 ft.  
3d. 25 to 35 ft.; 4th. 35 to 45 ft.

**Sizes of Pipe for Gravity Hot-Water Heating.** (John Jaeger, *Heating and Ventilating Mag.*, Feb., 1912.)—The assumed temperature of the water supplied to the radiators is 185°, and the drop 36°, giving a mean temperature of 170°. The temperature difference creates a water pressure of 0.148 in. of water per foot of height. With the assumed heights, *H*, between the center of the boiler and the center of the radiator on the several floors, and the assumed lengths, *L*, of the circuit, making allowance for resistance of connections, as given in the table, and using the ordinary tables for flow of water in pipes, the figures for number of square feet of radiating surface that will be supplied by different sizes of pipe are obtained, assuming that each square foot emits 170 B. T. U. per hour.

Floor	<i>H</i> . Ft.	<i>L</i> . Ft.	Size of Pipe, In.				
			1/2	3/4	1	1 1/4	1 1/2
			Sq. Ft. of Radiating Surface.				
Basement.....	3.5	80	11	32	57	127	180
First floor.....	6	100	13	39	70	156	221
Second floor.....	19	125	22	62	130	238	377
Third floor.....	31	150	26.5	74	160	290	450
Fourth floor.....	42	175	29	81	175	314	490

**Heating by Hot Water, with Forced Circulation.**—The principal defect of gravity hot-water systems, that the motive force is only the difference in weight of two columns of water of different temperatures, is overcome by giving the water a forced circulation, either by means of a pump or by a steam ejector. For large installations a pump gives facilities for forcing the hot water to any distance required. The design of such a system is chiefly a problem in hydraulics. After determining the quantity of heat to be given out by each radiator, a certain drop in temperature is assumed, and from that the volume of water required by each radiator is calculated. The piping system then has to be designed so that it will carry the proper supply of water to each radiator without short-circuiting, and with a minimum total cost for power to force the water, for loss by radiation, and for interest, etc., on cost of plant. No short rules or formulæ have been established for designing a forced hot-water system, and each case has to be studied as an original problem to

be solved by application of the laws of heat transmission and hydraulics. Forced systems using steam ejectors have come into use to some extent in Europe in small installations, and some of them are described in the Transactions of the Amer. Soc'y of Heating and Ventilating Engineers.

A system of distributing heat and power to customers by means of hot water pumped from a central station was adopted by the Boston Heating Co. in 1888. It was not commercially successful. A description of the plant is given by A. V. Abbott in *Trans. A. I. M. E.*, 1888.

**Corrosion of Pipe in Hot-Water Heating Systems.**—The chief agent of internal corrosion in hot-water pipes appears to be oxygen dissolved in the water. If this is removed corrosion is prevented. Buildings equipped with closed heating systems have suffered serious damage in six or eight years, while no such damage has been found in open or vented systems, in which the air dissolved in the water is allowed to escape in an open tank placed at the top of the system. (F. N. Speller, *Eng. News*, Feb. 13, 1913.)

### THE BLOWER SYSTEM OF HEATING.

The system provides for the use of a fan or blower which takes its supply of fresh air from the outside of the building to be heated, forces it over steam coils, located either centrally or divided up into a number of independent groups, and then into the several ducts or flues leading to the various rooms. The movement of the warmed air is positive, and the delivery of the air to the various points of supply is certain and entirely independent of atmospheric conditions.

**Advantages and Disadvantages of the Plenum System.** (Prof. W. F. Barrett, *Brit. Inst. H. & V. Engrs.*, 1905.)—Advantages: (1) The evenness of temperature produced; (2) the ventilation of the building is concurrent with its warming; (3) the air can be drawn from sources free from contamination and can be filtered from suspended impurities, warmed and brought to the proper hygrometric state before its introduction to the different rooms or wards; (4) the degree of temperature and of ventilation can be easily controlled in any part of the building, and (5) the removal of ugly pipes running through the rooms has a great architectural and esthetic advantage.

Disadvantages: (1) The most obvious is that no windows can be opened nor doors left open; double doors with an air lock between must also be provided if the doors are frequently opened and closed; (2) the mechanical arrangements are elaborate and the system requires to be used with intelligent care; (3) the whole elaborate system needs to be set going even if only one or two rooms in a large building require to be warmed, as often happens in the winter vacation of a college; (4) the temporary failure of the system, through the breakdown of the engines or other cause, throws the whole system into confusion, and if, as in the Royal Victoria Hospital, the windows are not made to open, imminent danger results; (5) then, also, in the case of hospital wards and asylums it is possible that the outlet ducts may become coated with disease germs, and unless periodically cleansed, a back current through a high wind or temporary failure of the system may bring a cloud of these disease germs back into the wards.

**Heat Radiated from Coils in the Blower System.**—The committee on Fan-blast Heating, of the A. S. H. V. E., in 1909, gives the following formula for amount of heat radiated from hot-blast coils with different velocities of air passing through the heater:  $E = B.T.U.$  per sq. ft. of surface per hour per degree of difference between the average temperature of the air and the steam temperature,  $= \sqrt{4V}$ , in which  $V =$  velocity of the air through the free area of the coil in feet per second. A plotted curve of 20 tests of different heaters shows that the formula represents the average results, but individual tests show a wide variation from the average, thus: For velocity 1000 ft. per min., average 9 B.T.U., range 7.5 to 11; 1600 ft. per min., average 10.4, range 9.5 to 12.

The committee also gives the following formula for the rise in temperature of each two-row section of a coil:

$$R = \frac{(T_s - T_a) \times H \times E}{A \times V_m \times W \times 60 \times 0.2377}$$

In which  $R =$  degrees F. rise for each two-row section;  $T_s =$  tem-

perature of steam;  $T_a$  = temperature of air;  $H$  = square feet of surface in two-row section;  $E$  = B.T.U. per degree difference between air and steam;  $E = \sqrt{4 V_s}$ , in which  $V_s$  = air velocity in ft. per sec.;  $A$  = area through heater in sq. ft.;  $V_m$  = velocity of air in ft. per min.;  $W$  = weight of 1 cu. ft. of air, lbs.

The value of  $R$  is computed for each two-row section in a coil, and the results added. From a set of curves plotted from the formula the following figures are taken.

	Number of Rows.						
	4	8	12	16	20	24	28
	Temperature Rise, Degrees.						
Steam, 80 lbs. $V_m = 1,200$ .....	43	83	115	144	167	189	209
Steam, 80 lbs. $V_m = 1,800$ .....	36	68	96	122	145	165	182
Steam, 5 lbs. $V_m = 1,200$ .....	31	53	80	100	118	133	146
Steam, 5 lbs. $V_m = 1,800$ .....	25	48	68	85	101	115	128

A formula for the rise in temperature of air in passing through the coils of a hot-blast heater is given by Perry West, *Trans. A. S. H. V. E.*, 1909, page 57, as follows:  $R = KDZ^m N \div \sqrt[n]{V}$ , in which  $R$  = rise in temperature of the air;  $K$  = a constant depending on the kind of heating surface;  $D$  = an average of the summation of temperature differences between the air and the steam =  $(T_1 - T_0) \div \log_e [(T_s - T_0) \div (T_s - T_1)]$ ;  $Z$  = number of sq. ft. of heating surface per sq. ft. of clear area per unit depth of heater.  $m$  = a power applicable to  $Z$  and depending on the type of heating surface;  $N$  = number of units in depth of heater;  $V$  = velocity of the air at 70° F. in ft. per min. through the clear area;  $n$  = a root applicable to  $V$  and depending on experiment.

For practical purposes and within the range of present knowledge on the subject the formula may be written  $R = 0.085 DZN \div \sqrt[3]{V}$ , and from this formula with  $T_s = 227^\circ$  and  $T_0 = 0^\circ$ , with different values of  $T_1$ , the temperature of the air leaving the coils, a set of curves is plotted, from which the figures in the following table are taken.

Velocity, Ft. per Min.	Sq. ft. of heating surface ÷ sq. ft. free area through heater.									
	20	30	40	50	60	70	80	90	100	120
	Rise in Temperature, Degrees F.									
500.....	43	63	79	95	108	120	131	141	151	170
800.....	38	55	70	84	97	108	118	128	138	157
1000.....	36	52	66	79	92	102	112	121	130	147
1200.....	34	49	63	75	87	98	108	117	125	140
2000.....	29	42	55	66	76	86	95	104	112	127

Burt S. Harrison (*Htg. and Ventg. Mag.*, Oct. and Nov., 1907) gives the following formula,  $R = \frac{1}{\sqrt[3]{V}} (T - t) \frac{1}{8/N + 0.24}$ , in which  $T$  = temp. of steam

in coils,  $t$  = temp. of air entering coils,  $V$  = velocity of air through coils in ft. per sec.,  $N$  = no. of rows of 1-in. pipe in depth of heater. Charts are given by means of which heaters may be designed for any set of conditions.

**Tests of Cast-iron Heaters for Hot-blast Work.** — An extensive series of tests of the Amer. Radiator Co's, "Vento" cast-iron heater is described by Theo. Weinshank in *Trans. A. S. H. V. E.*, 1908. The tests were made under the supervision of Prof. J. H. Kinealy. The principal results are given in the table on page 710.



## TESTS OF A "VENTO" CAST-IRON HEATER.

Velocity, Ft. per Min.	Number of sections heater is deep.						Number of sections heater is deep.					
	1	2	3	4	5	6	1	2	3	4	5	6
	Rise of temperature, K, per degree difference between temperature of steam and mean temperature of air for different velocities of air.						Heat units transmitted per square foot of heating surface per hour per degree difference between the temperature of the steam and the mean temperature of the air.					
1600.....	0.124	0.253	0.395	0.527	0.649	0.761	11.94	12.17	12.67	12.67	12.50	12.20
1500.....	0.132	0.261	0.403	0.535	0.657	0.769	11.91	11.76	12.11	12.06	11.86	11.56
1400.....	0.139	0.268	0.410	0.542	0.664	0.776	11.70	11.28	11.50	11.41	11.18	10.89
1300.....	0.147	0.276	0.418	0.550	0.672	0.784	11.50	10.79	10.89	10.75	10.51	10.22
1200.....	0.154	0.283	0.425	0.557	0.679	0.791	11.11	10.21	10.22	10.05	9.81	9.52
1100.....	0.162	0.291	0.433	0.565	0.687	0.799	10.72	9.63	9.55	9.34	9.09	8.82
1000.....	0.170	0.299	0.441	0.573	0.695	0.807	10.23	8.99	8.84	8.61	8.36	8.10
900.....	0.177	0.306	0.448	0.580	0.702	0.814	9.59	8.28	8.08	7.85	7.60	7.35
800.....	0.185	0.314	0.456	0.588	0.710	0.822	8.90	7.56	7.31	7.08	6.48	6.60

Velocity, Ft. per Min.	Final temperature, T, of air when entering heater at 0° F. Temperature of steam in heater, 227°.						Friction loss in inches of water due to the sections.					
1600.....	26.5	51.0	74.9	94.7	111.3	125.2	0.236	0.288	0.416	0.543	0.672	0.800
1500.....	28.1	52.4	76.3	95.8	112.4	126.0	0.207	0.253	0.366	0.477	0.590	0.703
1400.....	29.5	53.8	77.2	96.7	113.3	126.8	0.180	0.220	0.318	0.415	0.514	0.613
1300.....	31.1	55.0	77.6	97.9	114.3	127.7	0.156	0.190	0.274	0.358	0.443	0.528
1200.....	32.4	56.4	79.6	99.0	115.3	128.7	0.133	0.162	0.234	0.306	0.378	0.450
1100.....	34.0	57.7	80.5	100.0	116.2	129.6	0.111	0.136	0.197	0.257	0.318	0.378
1000.....	35.6	59.1	82.0	100.1	117.2	130.5	0.092	0.112	0.162	0.212	0.262	0.312
900.....	36.9	60.1	83.0	102.1	118.0	131.3	0.074	0.091	0.132	0.172	0.212	0.253
800.....	38.5	61.6	84.3	103.1	119.0	132.3	0.059	0.072	0.104	0.136	0.167	0.200

Formulae.— $s$  = no. of sections;  $V$  = velocity, ft. per min., air measured at 70°;  $k$  = rise of temp. per degree difference;  $t$  = final temperature.  $f$  = friction loss in in. of water.  $t = 454k \div (2 + k)$ .  $k = s(0.167 - 0.005s) - 0.061 \left( \frac{v - 800}{800} \right)$ .  $f = (0.8s + 0.2)(V/4000)^2$ .  
Values of  $k$  and  $f$  when  $s = 2$  or more.

**Factory Heating by the Fan System.**

In factories where the space provided per operative is large, warm air is recirculated, sufficient air for ventilation being provided by leakage through the walls and windows. The air is commonly heated by steam coils furnished with exhaust steam from the factory engine. When the engine is not running, or when it does not supply enough exhaust steam for the purpose, steam from the boilers is admitted to the coils through a reducing valve. The following proportions are commonly used in designing. Coils, pipes 1-in., set  $2\frac{1}{8}$  in. centers; free area through coils, 40% of cross area. Velocity of air through free area, 1200 to 1800 ft. per min.; number of coils in series 8 to 20; circumferential speed of fan, 4000 to 6000 ft. per min.; temperature of air leaving coils, 120° to 160° F.; velocity of air at outlet of coil stack, 3000 to 4000 ft. per min.; velocity in branch pipes, 2000 to 2800 ft., the lower velocities in the longest pipes.

In factories in which mechanical ventilation as well as heating is required, outlet flues at proper points must be provided, to avoid the necessity of opening windows, and the outflow of air in them may be assisted either by exhaust fans or by steam coils in the flues.

**Cooling Air for Ventilation.**

The chief difficulty in the artificial cooling of air is due to the moisture it contains, and the great quantity of heat that has to be absorbed or abstracted from the air in order to condense this moisture. The cooled

and moisture-laden air also needs to be partially reheated in order to bring it to a degree of relative humidity that will make it suitable for ventilation. To cool 1 lb. of dry air from 82° to 72° requires the abstracting of  $10 \times 0.2375$  B.T.U. (0.2375 being the specific heat at constant pressure). If the air at 82° is saturated, or 100% relative humidity, it contains 0.0235 lb. of water vapor, while 1 lb. at 72° contains 0.0167 lb., so that 0.0068 lb. will be condensed in cooling from vapor at 82° to water at 72°. The total heat (above 32°) in 1 lb. vapor at 82° is 1095.6 B.T.U. and that in 1 lb. of water at 72° is 40 B.T.U. The difference,  $1055.6 \times 0.0068 = 7.178$  B.T.U., is the amount of heat abstracted in condensing the moisture. The B.T.U. in 1 lb. vapor at 72° is 1091.2. and the B.T.U. abstracted in cooling the remaining vapor from 82° to 72° is  $0.0167 \times (1095.6 - 1091.2) = 0.073$  B.T.U. The sum, 7.251 B.T.U., is more than three times that required to cool the dry air from 82° to 72°. Expressing these principles in formulæ we have:

Let  $T_1$  = original and  $T_2$  the final temperature of the air,  
 $a$  = vapor in 1 lb. saturated air at  $T_1$ ;  $b$  = do. at  $T_2$ ,  
 $H$  = relative humidity of the air at  $T_1$ ;  $h$  = desired do. at  $T_2$ ,  
 $U$  = total heat, in B.T.U., in 1 lb. vapor at  $T_1$ ;  $u$  = do. at  $T_2$ ,  
 $w$  = total heat in water at  $T_2$ .

Then total heat abstracted in cooling air from  $T_1$  to  $T_2 = (aH - bh) \times (U - w) + bh(U - u) + 0.2375(T_1 - T_2)$ , or  $aHU - bhu - (aH - bh)w + 0.2375(T_1 - T_2)$ , or  $aH(U - w) - bh(u - w) + 0.2375(T_1 - T_2)$ .

EXAMPLE.—Required the amount of heat to be abstracted per hour in cooling the air for an audience chamber containing 1000 persons, 1500 cu. ft. (measured at 70° F.), being supplied per person per hour, the temperature of the air before cooling being 82°, with relative humidity 80%, and after cooling 72°, with humidity 70%.

$1000 \times 1500 = 1,500,000$  cu. ft., at 0.075 lb. per cu. ft.  
 = 112,500 lbs.

For 1 lb.  $aH(U - w) - bh(u - w) + 0.2375(T_1 - T_2)$ .

$0.0235 \times 0.8 \times (1095.6 - 40) - 0.0167 \times 0.7 \times (1091.2 - 40) + 2.375 = 9.932$  B.T.U.

$112,500 \times 9.932 = 1,061,100$  B.T.U.

Taking 142 B.T.U. as the latent heat of melting ice, this amount is equivalent to the heat that would melt 7472 lbs. of ice per hour.

See also paper by W. W. Macon, *Trans. A. S. H. V. E.*, 1909, and Air-cooling of the New York Stock Exchange, *Eng. Rec.*, April, 1905, and *The Metal Worker*, Aug. 5, 1905.

**Capacities of Fans or Blowers for Hot-Blast or Plenum Heating.**

(Computed by F. R. Still, American Blower Co., Detroit, Mich.)

Size of Blower-Housing.	Diam. of Fan-Wheel.	Revolutions per Minute.	H. P. Required to Drive Fan.	Cu. Ft. of Air Delivered per Minute by Fan through Heater.	Cu. Ft. of Air per Hour.	Heat Units Required per Hour to Raise Air from 0° to 120°.	Velocity of Air through Coils in Ft. per Minute.	Free Area between Pipes in Sq. Ft.	Heat Units Given off per Sq. Ft. Surface per Hour.	Sq. Ft. Heating Surface Required.
70	42	360	21/2	6,900	415,200	1,021,000	900	7.7	1760	580
80	48	320	3	8,500	510,000	1,255,000	"	9.45	"	714
90	54	280	4	10,500	630,000	1,550,000	"	11.66	"	880
100	60	250	5	12,500	750,000	1,845,000	"	13.9	"	1050
110	66	230	6	15,800	948,000	2,335,000	"	17.55	"	1325
120	72	210	8	19,800	1,118,000	2,900,000	"	22.	"	1650
140	84	180	10	25,200	1,572,000	3,870,000	"	29.1	"	2200
160	96	160	12	33,000	1,980,000	4,870,000	"	36.7	"	2770
180	108	140	15	41,600	2,496,000	6,130,000	"	46.3	"	3490
200	120	125	18	50,000	3,000,000	7,375,000	"	55.5	"	4140

**Capacities of Fans or Blowers for Hot-blast or Plenum Heating —**  
*Continued.*

Size of Blower-Housing.	Lineal Feet of One-Inch Pipe Required.	Pounds of Steam Condensed per Hour to 212°.	Size Steam-Main Required.	Size Return-Main Required.	Boiler Capacity Required, H.P.; 30 Lbs. Steam per Hour = 1 H.P.	Sq. Ft. Heating Surface in Boiler at 15 Sq. Ft. per H.P.	Sq. Ft. Grate-Surface at 35 Sq. Ft. Heating Surface to Sq. Ft. Grate.	Volume Air Will Expand to by Heating from 0° to 120° Capacity per Minute.	Area of Conduit in Sq. Ft. for 900 Ft. Velocity per Minute.	Net Volume Delivered, Allowance Being Made for Friction Equal to 100 Ft. of Conduit.
70	1,740	1055	3 1/2	2	35	525	15	8,700	9.67	8,200
80	2,142	1295	4	2	43	645	18	10,700	13.05	10,000
90	2,640	1600	4 1/2	2 1/2	53	795	23	13,200	14.72	12,500
100	3,150	1900	5	2 1/2	63	945	27	15,800	17.55	15,000
110	3,975	2410	5 1/2	3	80	1200	34	19,900	22.20	18,900
120	4,950	2990	6	3	100	1500	43	25,000	27.80	23,800
140	6,600	3990	7	3 1/2	133	1995	57	33,100	36.80	31,400
160	8,310	5025	8	4	167	2505	72	41,700	46.30	39,600
180	10,470	6325	9	4 1/2	211	3165	90	52,500	58.40	50,000
200	12,420	7560	10	5	252	3780	108	63,200	70.25	60,000

Temperature of fresh air, 0°; of air from coils, 120°; of steam, 227°; Pressure of steam, 5 lbs.

Peripheral velocity of fan-tips, 4000 ft.; number of pipes deep in coil, 24; depth of coil, 60 inches; area of coils approximately twice free area.

**Relative Efficiency of Fans and Heated Chimneys for Ventilation.** — W. P. Trowbridge, *Trans. A. S. M. E.* vii. 531, gives a theoretical solution of the relative amounts of heat expended to remove a given volume of impure air by a fan and by a chimney. Assuming the total efficiency of a fan to be only  $\frac{1}{25}$ , which is made up of an efficiency of  $\frac{1}{10}$  for the engine,  $\frac{5}{10}$  for the fan itself, and  $\frac{8}{10}$  for efficiency as regards friction, the fan requires an expenditure of heat to drive it of only  $\frac{1}{38}$  of the amount that would be required to produce the same ventilation by a chimney 100 ft. high. For a chimney 500 ft. high the fan will be 7.6 times more efficient.

The following figures are given by Atkinson (*Coll. Engr.*, 1889), showing the minimum depth at which a furnace would be equal to a ventilating-machine, assuming that the sources of loss are the same in each case, *i.e.*, that the loss of fuel in a furnace from the cooling in the upcast is equivalent to the power expended in overcoming the friction in the machine, and also assuming that the ventilating-machine utilizes 60 per cent of the engine-power. The coal consumption of the engine per I.H.P. is taken at 8 lbs. per hour.

Average temperature in upcast . . . . . 100° F.    150° F.    200° F.  
Minimum depth for equal economy.. 960 yards. 1040 yards. 1130 yards.

### PERFORMANCE OF HEATING GUARANTEE.

**Heating a Building to 70° F. Inside when the Outside Temperature is Zero.** — It is customary in some contracts for heating to guarantee that the apparatus will heat the interior of the building to 70° in zero weather. As it may not be practicable to obtain zero weather for the purpose of a test, it may be difficult to prove the performance of the guarantee unless an equivalent test may be made when the outside temperature is above zero, heating the building to a higher temperature than 70°. The following method was proposed by the author (*Eng. Rec.*,



Aug. 11, 1894) for determining to what temperature the rooms should be heated for various temperatures of the outside atmosphere and of the steam or hot water in the radiators.

Let  $S$  = sq. ft. of surface of the steam or hot-water radiator;

$W$  = sq. ft. of surface of exposed walls, windows, etc.;

$T_s$  = temp. of the steam or hot water,  $T_1$  = temp. of inside of building or room,  $T_0$  = temp. of outside of building or room;

$a$  = heat-units transmitted per sq. ft. of surface of radiator per hour per degree of difference of temperature;

$b$  = average heat-units transmitted per sq. ft. of walls per hour per degree of difference of temperature, including allowance for ventilation.

It is assumed that within the range of temperatures considered Newton's law of cooling holds good, viz., that it is proportional to the difference of temperature between the two sides of the radiating-surface.

Then  $aS(T_s - T_1) = bW(T_1 - T_0)$ . Let  $\frac{bW}{aS} = C$ ; then

$$T_s - T_1 = C(T_1 - T_0); \quad T_1 = \frac{T_s + CT_0}{1 + C}; \quad C = \frac{T_s - T_1}{T_1 - T_0}.$$

If  $T_1 = 70$ , and  $T_0 = 0$ ,  $C = \frac{T_s - 70}{70}$ .

Let  $T_s = 140^\circ \quad 160^\circ \quad 180^\circ \quad 200^\circ \quad 212^\circ \quad 220^\circ \quad 250^\circ \quad 300^\circ$

Then  $C = 1 \quad 1.286 \quad 1.571 \quad 1.857 \quad 2.029 \quad 2.143 \quad 2.571 \quad 3.286$   
and from the formula  $T_1 = (T_s + CT_0) \div (1 + C)$  we find the inside temperatures corresponding to the given values of  $T_s$  and  $T_0$  which should be produced by an apparatus capable of heating the building to  $70^\circ$  in zero weather.

For  $T_0 = \quad -20 \quad -10 \quad 0 \quad 10 \quad 20 \quad 30 \quad 40^\circ \text{ F.}$

Inside Temperatures  $T_1$ .

For $T_s = 140^\circ \text{ F.}$	60	65	70	75	80	85	90
160	58.7	64.3	70	75.6	81.3	86.9	92.5
180	57.8	63.9	70	76.1	82.2	88.4	94.5
200	57.0	63.5	70	76.5	83.0	89.5	96.0
212	56.6	63.3	70	76.7	83.4	90.1	96.8
220	56.4	63.2	70	76.8	83.6	90.5	97.3
250	55.6	62.8	70	77.2	84.4	91.6	98.8
300	54.7	62.4	70	77.7	85.3	93.0	100.7

J. R. Allen (*Trans. A. S. H. V. E.*, 1908) develops a complex formula for the inside temperature which takes into consideration the fact that the coefficient of transmission of the radiator is not constant but increases with the temperature. With  $T_s = 227$  and a two-column cast-iron radiator he finds for  $T_0 = -20 \quad -10 \quad 0 \quad 10 \quad 20 \quad 30 \quad 40$

$T_1 = \quad 58 \quad 64 \quad 70 \quad 77.5 \quad 83 \quad 90 \quad 97$

For all values of  $T_0$  between  $-10$  and  $40$  these figures are within one degree of those computed by the author's method.

## ELECTRICAL HEATING.

**Heating by Electricity.** — If the electric currents are generated by a dynamo driven by a steam-engine, electric heating will prove very expensive, since the steam-engine wastes in the exhaust-steam and by radiation about 90% of the heat-units supplied to it. In direct steam-heating, with a good boiler and properly covered supply-pipes, we can utilize about 60% of the total heat value of the fuel. One pound of coal, with a heating value of 13,000 heat-units, would supply to the radiators about  $13,000 \times 0.60 = 7800$  heat-units. In electric heating, suppose we have a first-class condensing-engine developing 1 H.P. for every 2 lbs. of coal burned per hour. This would be equivalent to 1,980,000 ft.-lbs.  $\div$

778 = 2545 heat-units, or 1272 heat-units for 1 lb. of coal. The friction of the engine and of the dynamo and the loss by electric leakage and by heat radiation from the conducting wires might reduce the heat-units delivered as electric current to the electric radiator, and there converted into heat, to 50% of this, or only 636 heat-units, or less than one twelfth of that delivered to the steam-radiators in direct steam-heating. Electric heating, therefore, will prove uneconomical unless the electric current is derived from water or wind power which would otherwise be wasted. (See Electrical Engineering.)

### MINE-VENTILATION.

**Friction of Air in Underground Passages.**—In ventilating a mine or other underground passage the resistance to be overcome is, according to most writers on the subject, proportional to the extent of the frictional surface exposed; that is, to the product  $lo$  of the length of the gangway by its perimeter, to the density of the air in circulation, to the square of its average speed,  $v$ , and lastly to a coefficient  $k$ , whose numerical value varies according to the nature of the sides of the gangway and the irregularities of its course.

The formula for the loss of head, neglecting the variation in density as unimportant, is  $p = \frac{ksv^2}{a}$ , in which  $p$  = loss of pressure in pounds per square foot,  $s$  = square feet of rubbing-surface exposed to the air,  $v$  the velocity of the air in feet per minute,  $a$  the area of the passage in square feet, and  $k$  the coefficient of friction. W. Fairley, in *Colliery Engineer*, Oct. and Nov., 1893, gives the following formulæ for all the quantities involved, using the same notation as the above, with these additions:  $h$  = horse-power of ventilation;  $l$  = length of air-channel;  $o$  = perimeter of air-channel;  $q$  = quantity of air circulating in cubic feet per minute;  $u$  = units of work, in foot-pounds, applied to circulate the air;  $w$  = water-gauge in inches. Then,

$$1. \quad a = \frac{ksv^2}{p} = \frac{ksv^2q}{u} = \frac{ksv^3}{pv} = \frac{u}{pv} = \frac{q}{v}.$$

$$2. \quad h = \frac{u}{33,000} = \frac{qp}{33,000} = \frac{5.2 qw}{33,000}.$$

$$3. \quad k = \frac{pa}{sv^2} = \frac{u}{sv^3} = \frac{p}{sv^2 + a} = \frac{5.2 w}{sv^2 + a}.$$

$$4. \quad l = \frac{s}{o} = \frac{pa}{kv^2o}.$$

$$5. \quad o = \frac{s}{l} = \frac{pa}{kv^2l}.$$

$$6. \quad p = \frac{ksv^2}{a} = \frac{u}{q} = 5.2 w = \left( \sqrt[3]{\frac{u}{ks}} \right)^2 \frac{ks}{a} = \frac{ksv^3}{q} = \frac{u}{av}.$$

$$7. \quad pa = ksv^2 = \left( \sqrt[3]{\frac{u}{ks}} \right)^2 ks = \frac{u}{v}; \quad pa^3 = ksq^2.$$

$$8. \quad q = va = \frac{u}{p} = \frac{ksv^3}{p} = \sqrt{\frac{pa}{ks}} a = \sqrt{\frac{u}{ks}} a.$$

$$9. \quad s = \frac{pa}{kv^2} = \frac{u}{kv^3} = \frac{qp}{kv^3} = \frac{vpa}{kv^3} = lo.$$

$$10. \quad u = qp = vpa = \frac{ksv^2q}{a} = ksv^3 = 5.2 qw = 33,000 h.$$

$$11. \quad v = \frac{u}{pa} = \frac{q}{a} = \sqrt[3]{\frac{u}{ks}} = \sqrt[3]{\frac{qp}{ks}} = \sqrt{\frac{pa}{ks}}.$$

$$12. \quad v^2 = \frac{pa}{ks} = \left( \sqrt[3]{\frac{u}{ks}} \right)^2.$$

$$13. v^3 = \frac{u}{ks} = \frac{qp}{ks} = \frac{vpa}{ks}.$$

$$14. w = \frac{p}{5.2} = \frac{ksv^2}{5.2a}.$$

To find the quantity of air with a given horse-power and efficiency (*e*) of engine:

$$q = \frac{h \times 33,000 \times e}{p}.$$

The value of *k*, the coefficient of friction, as stated, varies according to the nature of the sides of the gangway. Widely divergent values have been given by different authorities (see *Colliery Engineer*, Nov., 1893), the most generally accepted one until recently being probably that of J. J. Atkinson, .0000000217, which is the pressure per square foot in decimals of a pound for each square foot of rubbing-surface and a velocity of one foot per minute. Mr. Fairley, in his "Theory and Practice of Ventilating Coal-mines," gives a value less than half of Atkinson's or .00000001; and recent experiments by D. Murgue show that even this value is high under most conditions. Murgue's results are given in his paper on Experimental Investigations in the Loss of Head of Air-currents in Underground Workings, *Trans. A. I. M. E.*, 1893, vol. xxiii. 63. His coefficients are given in the following table, as determined in twelve experiments:

		Coefficient of Loss of Head by Friction.	
		French.	British.
Rock gangways.	{ Straight, normal section.....	.00092	.000,000,00486
	{ Straight, normal section.....	.00094	.000,000,00497
	{ Straight, large section.....	.00104	.000,000,00549
	{ Straight, normal section.....	.00122	.000,000,00645
Brick-lined arched gangways.	{ Straight, normal section.....	.00030	.000,000,00158
	{ Straight, normal section.....	.00036	.000,000,00190
	{ Continuous curve, normal section	.00062	.000,000,00328
	{ Sinuous, intermediate section....	.00051	.000,000,00269
Timbered gangways.	{ Sinuous, small section.....	.00055	.000,000,00291
	{ Straight, normal section.....	.00168	.000,000,00888
	{ Straight, normal section.....	.00144	.000,000,00761
	{ Slightly sinuous, small section...	.00238	.000,000,01257

The French coefficients which are given by Murgue represent the height of water-gauge in millimeters for each square meter of rubbing-surface and a velocity of one meter per second. To convert them to the British measure of pounds per square foot for each square foot of rubbing-surface and a velocity of one foot per minute they have been multiplied by the factor of conversion, .000005283. For a velocity of 1000 feet per minute, since the loss of head varies as *v*<sup>2</sup>, move the decimal point in the coefficients six places to the right.

**Equivalent Orifice.** — The head absorbed by the working-chambers of a mine cannot be computed *a priori*, because the openings, cross-passages, irregular-shaped gob-piles, and daily changes in the size and shape of the chambers present much too complicated a network for accurate analysis. In order to overcome this difficulty Murgue proposed in 1872 the method of *equivalent orifice*. This method consists in substituting for the mine to be considered the equivalent thin-lipped orifice, requiring the same height of head for the discharge of an equal volume of air. The area of this orifice is obtained when the head and the discharge are known, by means of the following formulæ, as given by Fairley:

Let *Q* = quantity of air in thousands of cubic feet per minute;  
*w* = inches of water-gauge;  
*A* = area in square feet of equivalent orifice.

Then

$$A = \frac{0.37 Q}{\sqrt{w}} = \frac{Q}{2.7 \sqrt{w}}; * \quad Q = \frac{A \times \sqrt{w}}{0.37}; \quad w = 0.1369 \times \left(\frac{Q}{A}\right)^2.$$

\* Murgue gives  $A = \frac{0.38 Q}{\sqrt{w}}$ , and Norris  $A = \frac{0.403 Q}{\sqrt{w}}$ . See page 672, *ante*.



### Motive Column or the Head of Air Due to Differences of Temperature, etc. (Fairley.)

Let  $M$  = motive column in feet;  
 $T$  = temperature of upcast;  
 $f$  = weight of one cubic foot of the flowing air;  
 $t$  = temperature of downcast;  
 $D$  = depth of downcast.

Then

$$M = D \frac{T-t}{T \times 459} \text{ or } \frac{5.2 \times w}{f}; p = f \times M; w = \frac{f \times M}{5.2} = \frac{p}{5.2}.$$

To find diameter of a round airway to pass the same amount of air as a square airway, the length and power remaining the same:

Let  $D$  = diameter of round airway,  $A$  = area of square airway;  $O$  = perimeter of square airway. Then  $D^3 = \sqrt[5]{\frac{A^3 \times 3.1416}{0.7854^3 \times O}}$ .

If two fans are employed to ventilate a mine, each of which when worked separately produces a certain quantity, which may be indicated by  $A$  and  $B$ , then the quantity of air that will pass when the two fans are worked together will be  $\sqrt[3]{A^3 + B^3}$ . (For mine-ventilating fans, see page 672.)

## WATER.

**Expansion of Water.** — The following table gives the relative volumes of water at different temperatures, compared with its volume at 4° C. according to Köpp, as corrected by Porter.

Cent.	Fahr.	Volume.	Cent.	Fahr.	Volume.	Cent.	Fahr.	Volume.
4°	39.1°	1.00000	35°	95°	1.00586	70°	158°	1.02241
5	41	1.00001	40	104	1.00767	75	167	1.02548
10	50	1.00025	45	113	1.00967	80	176	1.02872
15	59	1.00083	50	122	1.01186	85	185	1.03213
20	68	1.00171	55	131	1.01423	90	194	1.03570
25	77	1.00286	60	140	1.01678	95	203	1.03943
30	86	1.00425	65	149	1.01951	100	212	1.04332

Weight of 1 cu. ft. at 39.1° F. = 62.4245 lb. ÷ 1.04332 = 59.833, weight of 1 cu. ft. at 212° F.

**Weight of Water at Different Temperatures.** — The weight of water at maximum density, 39.1°, is generally taken at the figure given by Rankine, 62.425 lbs. per cubic foot. Some authorities give as low as 62.379. The figure 62.5 commonly given is approximate. The highest authoritative figure is 62.428. At 62° F. the figures range from 62.291 to 62.360. The figure 62.355 is generally accepted as the most accurate.

At 32° F. figures given by different writers range from 62.379 to 62.418. Hamilton Smith, Jr. (from Rosetti) gives 62.416.

**Weight of Water at Temperatures above 200° F.** (Landolt and Börnstein's Tables, 1905.)

Deg. F.	Lbs. Per Cu. Ft.	Deg. F.	Lbs. Per Cu. Ft.	Deg. F.	Lbs. Per Cu. Ft.	Deg. F.	Lbs. Per Cu. Ft.	Deg. F.	Lbs. Per Cu. Ft.	Deg. F.	Lbs. Per Cu. Ft.
200	60.12	270	58.26	340	55.94	410	53.0	480	49.7	550	45.6
210	59.88	280	57.96	350	55.57	420	52.6	490	49.2	560	44.9
220	59.63	290	57.65	360	55.18	430	52.2	500	48.7	570	44.1
230	59.37	300	57.33	370	54.78	440	51.7	510	48.1	580	43.3
240	59.11	310	57.00	380	54.36	450	51.2	520	47.6	590	42.6
250	58.83	320	56.66	390	53.94	460	50.7	530	47.0	600	41.8
260	58.55	330	56.30	400	53.5	470	50.2	540	46.3		

Weight of Water per Cubic Foot, from 32° to 212° F., and heat-units per pound, reckoned above 32° F.: The figures for weight of water in following table, made by interpolating the table given by Clark as calculated from Rankine's formula, with corrections for apparent errors, was published by the author in 1884, *Trans. A. S. M. E.*, vi. 90. The figures for heat units are from Marks and Davis's Steam Tables, 1909.

Temp., deg. F.	Weight, lbs. per cubic foot.	Heat-units.	Temperature, deg. F.	Weight, lbs. per cubic foot.	Heat-units.	Temperature, deg. F.	Weight, lbs. per cubic foot.	Heat-units.	Temperature, deg. F.	Weight, lbs. per cubic foot.	Heat-units.	Temperature, deg. F.	Weight, lbs. per cubic foot.	Heat-units.
32	62.42	0.	78	62.25	46.04	123	61.68	90.90	168	60.81	135.86			
33	62.42	1.01	79	62.24	47.04	124	61.67	91.90	169	60.79	136.86			
34	62.42	2.02	80	62.23	48.03	125	61.65	92.90	170	60.77	137.87			
35	62.42	3.02	81	62.22	49.03	126	61.63	93.90	171	60.75	138.87			
36	62.42	4.03	82	62.21	50.03	127	61.61	94.89	172	60.73	139.87			
37	62.42	5.04	83	62.20	51.02	128	61.60	95.89	173	60.70	140.87			
38	62.42	6.04	84	62.19	52.02	129	61.58	96.89	174	60.68	141.87			
39	62.42	7.05	85	62.18	53.02	130	61.56	97.89	175	60.66	142.87			
40	62.42	8.05	86	62.17	54.01	131	61.54	98.89	176	60.64	143.87			
41	62.42	9.05	87	62.16	55.01	132	61.52	99.88	177	60.62	144.88			
42	62.42	10.06	88	62.15	56.01	133	61.51	100.88	178	60.59	145.88			
43	62.42	11.06	89	62.14	57.00	134	61.49	101.88	179	60.57	146.88			
44	62.42	12.06	90	62.13	58.00	135	61.47	102.88	180	60.55	147.88			
45	62.42	13.07	91	62.12	59.00	136	61.45	103.88	181	60.53	148.88			
46	62.42	14.07	92	62.11	60.00	137	61.43	104.87	182	60.50	149.89			
47	62.42	15.07	93	62.10	60.99	138	61.41	105.87	183	60.48	150.89			
48	62.41	16.07	94	62.09	61.99	139	61.39	106.87	184	60.46	151.89			
49	62.41	17.08	95	62.08	62.99	140	61.37	107.87	185	60.44	152.89			
50	62.41	18.08	96	62.07	63.98	141	61.36	108.87	186	60.41	153.89			
51	62.41	19.08	97	62.06	64.98	142	61.34	109.87	187	60.39	154.90			
52	62.40	20.08	98	62.05	65.98	143	61.32	110.87	188	60.37	155.90			
53	62.40	21.08	99	62.03	66.97	144	61.30	111.87	189	60.34	156.90			
54	62.40	22.08	100	62.02	67.97	145	61.28	112.86	190	60.32	157.91			
55	62.39	23.08	101	62.01	68.97	146	61.26	113.86	191	60.29	158.91			
56	62.39	24.08	102	62.00	69.96	147	61.24	114.86	192	60.27	159.91			
57	62.39	25.08	103	61.99	70.96	148	61.22	115.86	193	60.25	160.91			
58	62.38	26.08	104	61.97	71.96	149	61.20	116.86	194	60.22	161.92			
59	62.38	27.08	105	61.96	72.95	150	61.18	117.86	195	60.20	162.92			
60	62.37	28.08	106	61.95	73.95	151	61.16	118.86	196	60.17	163.92			
61	62.37	29.08	107	61.93	74.95	152	61.14	119.86	197	60.15	164.93			
62	62.36	30.08	108	61.92	75.95	153	61.12	120.86	198	60.12	165.93			
63	62.36	31.07	109	61.91	76.94	154	61.10	121.86	199	60.10	166.94			
64	62.35	32.07	110	61.89	77.94	155	61.08	122.86	200	60.07	167.94			
65	62.34	33.07	111	61.88	78.94	156	61.06	123.86	201	60.05	168.94			
66	62.34	34.07	112	61.86	79.93	157	61.04	124.86	202	60.02	169.95			
67	62.33	35.07	113	61.85	80.93	158	61.02	125.86	203	60.00	170.95			
68	62.33	36.07	114	61.83	81.93	159	61.00	126.86	204	59.97	171.96			
69	62.32	37.06	115	61.82	82.92	160	60.98	127.86	205	59.95	172.96			
70	62.31	38.06	116	61.80	83.92	161	60.96	128.86	206	59.92	173.97			
71	62.31	39.06	117	61.78	84.92	162	60.94	129.86	207	59.89	174.97			
72	62.30	40.05	118	61.77	85.92	163	60.92	130.86	208	59.87	175.98			
73	62.29	41.05	119	61.75	86.91	164	60.90	131.86	209	59.84	176.98			
74	62.28	42.05	120	61.74	87.91	165	60.87	132.86	210	59.82	177.99			
75	62.28	43.05	121	61.72	88.91	166	60.85	133.86	211	59.79	178.99			
76	62.27	43.04	122	61.70	89.91	167	60.83	134.86	212	59.76	180.00			
77	62.26	45.04												

Later authorities give figures for the weight of water which differ in the second decimal place only from those given above, as follows:

Temp. F. . . . .	40	50	60	70	80	90
Lbs. per cu. ft. . . . .	62.43	62.42	62.37	62.30	62.22	62.11
Temp. F. . . . .	100	110	120	130	140	150
Lbs. per cu. ft. . . . .	62.00	61.86	61.71	61.55	61.38	61.18
Temp. F. . . . .	160	170	180	190	200	210
Lbs. per cu. ft. . . . .	61.00	60.80	60.50	60.36	60.12	59.88

### Comparison of Heads of Water in Feet with Pressures in Various Units.

One foot of water at 39.1° Fahr.	=	62.425 lbs. on the square foot;
“ “ “	=	0.4335 lbs. on the square inch;
“ “ “	=	0.0295 atmosphere;
“ “ “	=	0.8823 inch of mercury at 32°;
“ “ “	=	773.3 } feet of air at 32° and at. nospheric pressure;
One lb. on the square foot, at 39.1° Fahr.	=	0.01602 foot of water;
One lb. on the square inch, at 39.1° Fahr.	=	2.307 feet of water;
One atmosphere of 29.922 in. of mercury	=	33.9 feet of water;
One inch of mercury at 32°	=	1.133 feet of water;
One foot of air at 32°, and 1 atmosphere.	=	0.001293 feet of water;
One foot of average sea-water	=	1.026 foot of pure water;
One foot of water at 62° F.	=	62.355 lbs. per sq. foot;
One foot of water at 62° F.	=	0.43302 lb. per sq. inch;
One inch of water at 62° F.	=	0.5774 ounce = 0.036085 lb. per sq. inch;
One lb. of water on the square inch at 62° F.	=	2.3094 feet of water.
One ounce of water on the square inch at 62° F.	=	1.732 inches of water.

### Pressure in Pounds per Square Inch for Different Heads of Water.

At 62° F. 1 foot head = 0.433 lb. per square inch,  $0.433 \times 144 = 62.352$  lbs. per cubic foot.

Head, feet.	0	1	2	3	4	5	6	7	8	9
0		0.433	0.866	1.299	1.732	2.165	2.598	3.031	3.464	3.897
10	4.330	4.763	5.196	5.629	6.062	6.495	6.928	7.361	7.794	8.227
20	8.660	9.093	9.525	9.959	10.392	10.825	11.258	11.691	12.124	12.557
30	12.990	13.423	13.856	14.289	14.722	15.155	15.588	16.021	16.454	16.887
40	17.320	17.753	18.186	18.619	19.052	19.485	19.918	20.351	20.784	21.217
50	21.650	22.083	22.516	22.949	23.382	23.815	24.248	24.681	25.114	25.547
60	25.980	26.413	26.846	27.279	27.712	28.145	28.578	29.011	29.444	29.877
70	30.310	30.743	31.176	31.609	32.042	32.475	32.908	33.341	33.774	34.207
80	34.640	35.073	35.505	35.939	36.372	36.805	37.238	37.671	38.104	38.537
90	38.970	39.403	39.836	40.269	40.702	41.135	41.568	42.001	42.436	42.867

### Head in Feet of Water, Corresponding to Pressures in Pounds per Square Inch.

1 lb. per square inch = 2.30947 feet head, 1 atmosphere = 14.7 lbs. per sq. inch = 33.94 ft. head.

Pressure.	0	1	2	3	4	5	6	7	8	9
0		2.309	4.619	6.928	9.238	11.547	13.857	16.166	18.476	20.785
10	23.0947	25.404	27.714	30.023	32.333	34.642	36.952	39.261	41.570	43.880
20	46.1894	48.499	50.808	53.118	55.427	57.737	60.046	62.356	64.665	66.975
30	69.2841	71.594	73.903	76.213	78.522	80.831	83.141	85.450	87.760	90.069
40	92.3788	94.688	96.998	99.307	101.62	103.93	106.24	108.55	110.85	113.16
50	115.4735	117.78	120.09	122.40	124.71	127.02	129.33	131.64	133.95	136.26
60	138.5682	140.88	143.19	145.50	147.81	150.12	152.42	154.73	157.04	159.35
70	161.6629	163.97	166.28	168.59	170.90	173.21	175.52	177.83	180.14	182.45
80	184.7576	187.07	189.38	191.69	194.00	196.31	198.61	200.92	203.23	205.54
90	207.8523	210.16	212.47	214.78	217.09	219.40	221.71	224.02	226.33	228.64



**Pressure of Water due to its Weight.** — The pressure of still water in pounds per square inch against the sides of any pipe, channel, or vessel of any shape whatever is due solely to the "head," or height of the level surface of the water above the point at which the pressure is considered, and is equal to 0.43302 lb. per square inch for every foot of head, or 62.355 lbs. per square foot for every foot of head (at 62° F.).

The pressure per square inch is equal in all directions, downwards, upwards, or sideways, and is independent of the shape or size of the containing vessel.

The pressure against a vertical surface, as a retaining-wall, at any point is in direct ratio to the head above that point, increasing from 0 at the level surface to a maximum at the bottom. The total pressure against a vertical strip of a unit's breadth increases as the area of a right-angled triangle whose perpendicular represents the height of the strip and whose base represents the pressure on a unit of surface at the bottom; that is, it increases as the square of the depth. The sum of all the horizontal pressures is represented by the area of the triangle, and the resultant of this sum is equal to this sum exerted at a point one third of the height from the bottom. (The center of gravity of the area of a triangle is one third of its height.)

The horizontal pressure is the same if the surface is inclined instead of vertical.

(For an elaboration of these principles see Trautwine's Pocket-Book, or the chapter on Hydrostatics in any work on Physics. For dams, retaining-walls, etc., see Trautwine.)

The amount of pressure on the interior walls of a pipe has no appreciable effect upon the amount of flow.

**Buoyancy.** — When a body is immersed in a liquid, whether it float or sink, it is buoyed up by a force equal to the weight of the bulk of the liquid displaced by the body. The weight of a floating body is equal to the weight of the bulk of the liquid that it displaces. The upward pressure or buoyancy of the liquid may be regarded as exerted at the center of gravity of the displaced water, which is called the center of pressure or of buoyancy. A vertical line drawn through it is called the axis of buoyancy or of flotation. In a floating body at rest a line joining the center of gravity and the center of buoyancy is vertical, and is called the axis of equilibrium. When an external force causes the axis of equilibrium to lean, if a vertical line be drawn upward from the center of buoyancy to this axis, the point where it cuts the axis is called the *metacenter*. If the metacenter is above the center of gravity the distance between them is called the metacentric height, and the body is then said to be in stable equilibrium, tending to return to its original position when the external force is removed.

**Boiling-point.** — Water boils at 212° F. (100° C.) at mean atmospheric pressure at the sea-level, 14.696 lbs. per square inch. The temperature at which water boils at any given pressure is the same as the temperature of saturated steam at the same pressure. For boiling-point of water at other pressure than 14.696 lbs. per square inch, see table of the Properties of Saturated Steam.

**The Boiling-point of Water may be Raised.** — When water is entirely freed of air, which may be accomplished by freezing or boiling, the cohesion of its atoms is greatly increased, so that its temperature may be raised over 50° above the ordinary boiling-point before ebullition takes place. It was found by Faraday that when such air-freed water did boil the rupture of the liquid was like an explosion. When water is surrounded by a film of oil, its boiling temperature may be raised considerably above its normal standard. This has been applied as a theoretical explanation in the instance of boiler explosions.

The freezing-point also may be lowered, if the water is perfectly quiet, to -10° C., or 18° Fahrenheit below the normal freezing-point. (Hamilton Smith, Jr., on Hydraulics, p. 13.)

**Freezing-point.** — Water freezes at 32° F. at the ordinary atmospheric pressure, and ice melts at the same temperature. In the melting of 1 pound of ice into water at 32° F. about 142 heat-units are absorbed, or become latent; and in freezing 1 lb. of water into ice a like quantity of heat is given out to the surrounding medium.

**Sea-water freezes at 27° F.** The ice is fresh. (Trautwine.)

**Ice and Snow.** (From Clark.) — 1 cubic foot of ice at 32° F. weighs 57.50 lbs.; 1 pound of ice at 32° F. has a volume of 0.0174 cu. ft. = 30.067 cu. in.

Relative volume of ice to water at 32° F., 1.0855, the expansion in passing into the solid state being 8.55%. Specific gravity of ice = 0.922, water at 62° F. being 1.

At high pressures the melting-point of ice is lower than 32° F., being at the rate of 0.0133° F. for each additional atmosphere of pressure.

The specific heat of ice is 0.504, that of water being 1.

1 cubic foot of fresh snow, according to humidity of atmosphere: 5 lbs. to 12 lbs. 1 cubic foot of snow moistened and compacted by rain: 15 lbs. to 50 lbs. (Trautwine.)

The latent heat of fusion of ice is 143.6 B.T.U. per lb.

**Specific Heat of Water.** (From Davis and Marks's Steam Tables.)

Deg. F.	Sp. Ht.	Deg. F.	Sp. Ht.	Deg. F.	Sp. Ht.	Deg. F.	Sp. Ht.	Deg. F.	Sp. Ht.	Deg. F.	Sp. Ht.
20	1.0168	120	0.9974	220	1.007	320	1.035	420	1.072	520	1.123
30	1.0098	130	0.9974	230	1.009	330	1.038	430	1.077	530	1.128
40	1.0045	140	0.9986	240	1.012	340	1.041	440	1.082	540	1.134
50	1.0012	150	0.9994	250	1.015	350	1.045	450	1.086	550	1.140
60	0.9990	160	1.0002	260	1.018	360	1.048	460	1.091	560	1.146
70	0.9977	170	1.0010	270	1.021	370	1.052	470	1.096	570	1.152
80	0.9970	180	1.0019	280	1.023	380	1.056	480	1.101	580	1.158
90	0.9967	190	1.0029	290	1.026	390	1.060	490	1.106	590	1.165
100	0.9967	200	1.0039	300	1.029	400	1.064	500	1.112	600	1.172
110	0.9970	210	1.0050	310	1.032	410	1.068	510	1.117		

These figures are based on the mean value of the heat unit, that is,  $\frac{1}{180}$  of the heat needed to raise 1 lb. of water from 32° to 212°.

**Compressibility of Water.** — Water is very slightly compressible. Its compressibility is from 0.000040 to 0.000051 for one atmosphere, decreasing with increase of temperature. For each foot of pressure distilled water will be diminished in volume 0.0000015 to 0.0000013. Water is so incompressible that even at a depth of a mile a cubic foot of water will weigh only about half a pound more than at the surface.

### THE IMPURITIES OF WATER.

(A. E. Hunt and G. H. Clapp, *Trans. A. I. M. E.*, xvii. 338.)

Commercial analyses are made to determine concerning a given water: (1) its applicability for making steam; (2) its hardness, or the facility with which it will "form a lather" necessary for washing; or (3) its adaptation to other manufacturing purposes.

At the Buffalo meeting of the Chemical Section of the A. A. A. S. it was decided to report all water analyses in parts per thousand, hundred-thousand, and million.

To convert grains per imperial (British) gallon into parts per 100,000, divide by 0.7. To convert parts per 100,000 into grains per U. S. gallon, multiply by 0.5835. To convert grains per U. S. gallon into parts per million multiply by 17.14.

The most common commercial analysis of water is made to determine its fitness for making steam. Water containing more than 5 parts per 100,000 of free sulphuric or nitric acid is liable to cause serious corrosion, not only of the metal of the boiler itself, but of the pipes, cylinders, pistons, and valves with which the steam comes in contact.

The total residue in water used for making steam causes the interior linings of boilers to become coated, and often produces a dangerous hard

scale, which prevents the cooling action of the water from protecting the metal against burning.

Lime and magnesia bicarbonates in water lose their excess of carbonic acid on boiling, and often, especially when the water contains sulphuric acid, produce, with the other solid residues constantly being formed by the evaporation, a very hard and insoluble scale. A larger amount than 100 parts per 100,000 of total solid residue will ordinarily cause troublesome scale, and should condemn the water for use in steam-boilers, unless a better supply cannot be obtained.

The following is a tabulated form of the causes of trouble with water for steam purposes, and the proposed remedies, given by Prof. L. M. Norton.

CAUSES OF INCRUSTATION.

1. Deposition of suspended matter.
2. Deposition of deposited salts from concentration.
3. Deposition of carbonates of lime and magnesia by boiling off carbonic acid, which holds them in solution.
4. Deposition of sulphates of lime, because sulphate of lime is but slightly soluble in cold water, less soluble in hot water, insoluble above 270° F.
5. Deposition of magnesia, because magnesium salts decompose at high temperature.
6. Deposition of lime soap, iron soap, etc., formed by saponification of grease.

MEANS FOR PREVENTING INCRUSTATION.

1. Filtration.
2. Blowing off.
3. Use of internal collecting apparatus or devices for directing the circulation.
4. Heating feed-water.
5. Chemical or other treatment of water in boiler.
6. Introduction of zinc into boiler.
7. Chemical treatment of water outside of boiler.

TABULAR VIEW.

Troublesome Substance.	Trouble.	Remedy or Palliation.
Sediment, mud, clay, etc.	Incrustation.	Filtration; blowing off.
Readily soluble salts.	"	Blowing off.
Bicarbonates of lime, magnesia, iron.	"	{ Heating feed. Addition of caustic soda, lime, or magnesia, etc.
Sulphate of lime.	"	{ Addition of carb. soda, barium hydrate, etc.
Chloride and sulphate of magnesium.	Corrosion.	{ Addition of carbonate of soda, etc.
Carbonate of soda in large amounts.	Priming.	{ Addition of barium chloride, etc.
Acid (in mine waters).	Corrosion.	Alkali.
Dissolved carbonic acid and oxygen.	Corrosion.	{ Feed milk of lime to the boiler, to form a thin internal coating.
Grease (from condensed water).	{ Corrosion or incrustation.	} Different cases require different remedies. Consult a specialist on the subject.
Organic matter (sewage).	{ Priming, corrosion, or incrustation.	

The mineral matters causing the most troublesome boiler-scales are bicarbonates and sulphates of lime and magnesia, oxides of iron and alumina, and silica. The analyses of some of the most common and troublesome boiler-scales are given in the following table:



## Analyses of Boiler-scale. (Chandler.)

	Sulphate of Lime.	Magnesia.	Silica.	Peroxide of Iron.	Water.	Carbonate of Lime.
N. Y. C. & H. R. Ry., No. 1	74.07	9.19	0.65	0.08	1.14	14.78
" " " No. 2	71.37	.....	1.76	.....	.....	.....
" " " No. 3	62.86	18.95	2.60	0.92	1.28	12.62
" " " No. 4	53.05	.....	4.79	.....	.....	.....
" " " No. 5	46.83	.....	5.32	.....	.....	.....
" " " No. 6	30.80	31.17	7.75	1.08	2.44	26.93
" " " No. 7	4.95	2.61	2.07	1.03	0.63	86.25
" " " No. 8	0.88	2.84	0.65	0.36	0.15	93.19
" " " No. 9	4.81	.....	2.92	.....	.....	.....
" " " No. 10	30.07	.....	8.24	.....	.....	.....

## Analyses in parts per 100,000 of Water giving Bad Results in Steam-boilers. (A. E. Hunt.)

	Bicarbonate of Lime deposited on Boiling.	Bicarbonate of Magnesia deposited on Boiling.	Total Lime.	Total Magnesia.	Sulphuric Acid.	Chlorine.	Iron.	Organic Matter.	Alumina.	Chloride of Sodium.
Coal-mine water.....	110	25	119	39	890	590	780	30	640	.....
Salt-well.....	151	38	190	48	360	990	38	21	30	1310
Spring.....	75	89	95	120	310	21	75	10	80	36
Monongahela River.....	130	21	161	33	210	38	70	.....	.....	.....
" " ".....	80	70	94	81	219	210	90	.....	.....	.....
" " ".....	32	82	61	104	28	190	38	.....	.....	.....
Allegheny R., near Oil-works..	30	50	41	68	890	42	23	.....	.....	.....

Many substances have been added with the idea of causing chemical action which will prevent boiler-scale. As a general rule, these do more harm than good, for a boiler is one of the worst possible places in which to carry on chemical reaction, where it nearly always causes more or less corrosion of the metal, and is liable to cause dangerous explosions.

In cases where water containing large amounts of total solid residue is necessarily used, a heavy petroleum oil, free from tar or wax, which is not acted upon by acids or alkalis, not having sufficient wax in it to cause saponification, and which has a vaporizing-point at nearly 600° F., will give the best results in preventing boiler-scale. Its action is to form a thin greasy film over the boiler linings, protecting them largely from the action of acids in the water and greasing the sediment which is formed, thus preventing the formation of scale and keeping the solid residue from the evaporation of the water in such a plastic suspended condition that it can be easily ejected from the boiler by the process of "blowing off." If the water is not blown off sufficiently often this sediment forms into a "putty" that will necessitate cleaning the boilers. Any boiler using bad water should be blown off every twelve hours.

**Hardness of Water.** — The hardness of water, or its opposite quality, indicated by the ease with which it will form a lather with soap, depends almost altogether upon the presence of compounds of lime and magnesia. Almost all soaps consist, chemically, of oleate, stearate, and palmitate of an alkaline base, usually soda and potash. The more lime and magnesia in a sample of water, the more soap a given volume of the water will decompose, so as to give insoluble oleate, palmitate, and stearate of lime and magnesia, and consequently the more soap must be added in order that the necessary quantity of soap may remain in solution to form the lather. The relative hardness of samples of water is generally expressed in terms of the number of standard soap-measures consumed by a gallon of water in yielding a permanent lather.

In Great Britain the standard soap-measure is the quantity required to precipitate one grain of carbonate of lime; in the U. S. it is the quantity required to precipitate one milligramme.

If a water charged with a bicarbonate of lime, magnesia, or iron is boiled, it will, on the excess of the carbonic acid being expelled, deposit a considerable quantity of the lime, magnesia, or iron, and consequently the water will be softer. The hardness of the water after this deposit of lime, after long boiling, is called the *permanent hardness* and the difference between it and the total hardness is called *temporary hardness*.

Lime salts in water react immediately on soap-solutions, precipitating the oleate, palmitate, or stearate of lime at once. Magnesia salts, on the contrary, require some considerable time for reaction. They are, however, more powerful hardeners; one equivalent of magnesia salts consuming as much soap as one and one-half equivalents of lime.

The presence of soda and potash salts softens rather than hardens water. Each grain of carbonate of lime per gallon of water causes an increased expenditure for soap of about 2 ounces per 100 gallons of water. (*Eng'g News*, Jan. 31, 1885.)

Low degrees of hardness (down to 200 parts of calcium carbonate (CaCO<sub>3</sub>) per million) are usually determined by means of a standard solution of soap. To 50 c.c. of the water is added alcoholic soap solution from a burette, shaking well after each addition, until a lather is obtained which covers the entire surface of the liquid when the bottle is laid on its side and which lasts five minutes. From the number of c.c. of soap solution used, the hardness of the water may be calculated by the use of Clark's table, given below, in parts of CaCO<sub>3</sub> per million.

c.c. Soap Sol.	Pts. CaCO <sub>3</sub> .	c.c. Soap Sol.	Pts. CaCO <sub>3</sub> .	c.c. Soap Sol.	Pts. CaCO <sub>3</sub> .	c.c. Soap Sol.	Pts. CaCO <sub>3</sub> .
0.7.....	0	4.0.....	46	8.0.....	103	12.0.....	164
1.0.....	5	5.0.....	60	9.0.....	118	13.0.....	180
2.0.....	19	6.0.....	74	10.0.....	133	14.0.....	196
3.0.....	32	7.0.....	89	11.0.....	148	15.0.....	212

For waters which are harder than 200 parts per million, a solution of soap ten times as strong may be used, the end or determining point being reached when sufficient soap has been added to deaden the harsh sound produced on shaking the bottle containing the water. — A. H. Gill, Engine-Room Chemistry.

**Purifying Feed-water for Steam-boilers.** (See also Incrustation and Corrosion, p. 927.) — When the water used for steam-boilers contains a large amount of scale-forming material it is usually advisable to purify it before allowing it to enter the boiler rather than to attempt the prevention of scale by the introduction of chemicals into the boiler. Carbonates of lime and magnesia may be removed to a considerable extent by simple heating of the water in an exhaust-steam feed-water heater or, still better, by a live-steam heater. (See circular of the Hoppes Mfg. Co., Springfield, O.) When the water is very bad it is best treated

with chemicals — lime, soda-ash, caustic soda, etc. — in tanks, the precipitates being separated by settling or filtering. For a description of several systems of water purification see a series of articles on the subject by Albert A. Cary in *Eng'g Mag.*, 1897.

Mr. H. E. Smith, chemist of the Chicago, Milwaukee & St. Paul Ry. Co., in a letter to the author, June, 1902, writes as follows concerning the chemical action of soda-ash on the scale-forming substances in boiler waters:

Soda-ash acts on carbonates of lime and magnesia in boiler water in the following manner: — The carbonates are held in solution by means of the carbonic acid gas also present which probably forms bicarbonates of lime and magnesia. Any means which will expel or absorb this carbonic acid will cause the precipitation of the carbonates. One of these means is soda ash (carbonate of soda), which absorbs the gas with the formation of bicarbonate of soda. This method would not be practicable for softening cold water, but it serves in a boiler. The carbonates precipitated in this manner are in flocculent condition instead of semi-crystalline as when thrown down by heat. In practice it is desirable and sufficient to precipitate only a portion of the lime and magnesia in flocculent condition. As to equations, the following represent what occurs: —

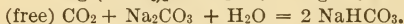
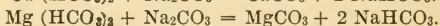
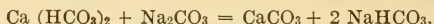

Chemical equivalents: — 106 pounds of pure carbonate of soda — equal to about 109 pounds of commercial 58 degree soda-ash — are chemically equivalent to — *i.e.*, react exactly with — the following weights of the substances named: Calcium sulphate, 136 lbs.; magnesium sulphate, 120 lbs.; calcium carbonate, 100 lbs.; magnesium carbonate, 84 lbs.; calcium chloride, 111 lbs.; magnesium chloride, 95 lbs.

Such numbers are simply the molecular weights of the substances reduced to a common basis with regard to the valence of the component atoms.

Important work in this line should not be undertaken by an amateur. "Recipes" have a certain field of usefulness, but will not cover the whole subject. In water purification, as in a problem of mechanical engineering, methods and apparatus must be adapted to the conditions presented. Not only must the character of the raw water be considered but also the conditions of purification and use.

**Water-softening Apparatus.** (From the Report of the Committee on Water Service, of the Am. Railway Eng'g and Maintenance of Way Assn., *Eng. Rec.*, April 20, 1907). — Between three and four hours is necessary for reaction and precipitation. Water taken from running streams in winter should have at least four hours' time. At least three feet of the bottom of each settling tank should be reserved for the accumulation of the precipitates.

The proper capacities for settling tanks, measured above the space reserved for sludge, can be determined as follows: *a* = capacity of softener in gallons per hour; *b* = hours required for reaction and precipitation; *c* = number of settling tanks (never less than two); *x* = number of hours required to fill the portion of settling tank above the sludge portion; *y* = number of hours required to transfer treated water from one settling tank to the storage tank (*y* should never be greater than *x*).

Where one pump alternates between filling and emptying settling tanks, *x* = *y*. Settling capacity in each tank =  $2ax = ab \div (c - 1)$ .

For plants where the quantity of water supplied to the softener and the capacity of the plant are equal, the settling capacity of each tank is equal to *ax*. The number of hours required to fill all the settling tanks should equal the number of hours required to fill, precipitate and empty one tank, as expressed by the following equation:  $cx = x + b + y$ .

$$\text{If } y = x, ax = ab \div (c - 2).$$

$$\text{If } y = 1/2 x, ax = ab + (c - 1.5).$$



An article on "The Present Status of Water Softening," by G. C. Whipple, in *Cass. Mag.*, Mar., 1907, illustrates several different forms of water-purifying apparatus. A classification of degrees of hardness corresponding to parts of carbonates and sulphates of lime and magnesia per million parts of water is given as follows: Very soft, 0 to 10 parts; soft, 10 to 20; slightly hard, 25 to 50; hard, 50 to 100; very hard, 100 to 200; excessively hard, 200 to 500; mineral water, 500 or more. The same article gives the following figures showing the quantity of chemicals required for the various constituents of hard water. For each part per million of the substances mentioned it is necessary to add the stated number of pounds per million gallons of lime and soda.

For Each Part per Million of	Pounds per Million Gallons.	
	Lime.	Soda.
Free CO <sub>2</sub> .....	10.62	0
Free acid (calculated as H <sub>2</sub> SO <sub>4</sub> ).....	4.77	9.03
Alkalinity.....	4.67	0
Incrustants.....	0.00	8.85
Magnesium.....	19.48	0

The above figures do not take into account any impurities in the chemicals. These have to be considered in actual operation.

An illustrated description of a water-purifying plant on the Chicago & Northwestern Ry. by G. M. Davidson is found in *Eng. News*, April 2, 1903. Two precipitation tanks are used, each 30 ft. diam., 16 ft. high, or 70,000 gallons each. As some water is left with the sludge in the bottom after each emptying, their net capacity is about 60,000 gallons each. The time required for filling, precipitating, settling and transferring the clear water to supply tanks is 12 hours. Once a month the sludge is removed, and it is found to make a good whitewash. Lime and soda-ash, in predetermined quantity, as found by analysis of the water, are used as precipitants. The following table shows the effect of treatment of well water at Council Bluffs, Iowa.

	Before Treatment.	After Treatment.
Total solid matter, grains per gallon.....	53.67	31.35
Carbonates of lime and magnesia.....	25.57	3.14
Sulphates of lime and magnesia.....	19.55	.....
Silica and oxides of iron and aluminum.....	1.76	0.40
Total incrusting solids.....	46.88	3.54
Alkali chlorides.....	1.21	1.27
Alkali sulphates.....	5.58	26.32
Total non-incrusting solids.....	6.79	27.81
Pounds scale-forming matter in 1000 gals.....	6.69	0.51

The minimum amount of scaling matter which will justify treatment cannot be stated in terms of analysis alone, but should be stated in terms of pounds incrusting matter held in solution in a day's supply. Besides the scale-forming solids, nearly all water contains more or less free carbonic acid. Sulphuric acid is also found, particularly in streams adjacent to coal mines. Serious trouble from corrosion will result from a small amount of this acid. In treating waters, the acids can be neutralized, and the incrusting matter can be reduced to at least 5 grains per gallon in most cases.

QUANTITY OF PURE REAGENTS REQUIRED TO REMOVE ONE POUND OF INCRUSTING OR CORROSIVE MATTER FROM THE WATER.

Incrusting or Corrosive Substance Held in Solution.	Amount of Reagent. (Pure.)	Foaming Matter Increased.
Sulphuric acid.....	0.57 lb. lime plus 1.08 lbs. soda ash	1.45 lbs.
Free carbonic acid.....	1.27 lbs. lime.....	None
Calcium carbonate.....	0.56 lb. lime.....	None
Calcium sulphate.....	0.78 lb. soda ash.....	1.04 lbs.
Calcium chloride.....	0.96 lb. soda ash.....	1.05 lbs.
Calcium nitrate.....	0.65 lb. soda ash.....	1.04 lbs.
Magnesium carbonate...	1.33 lbs. lime.....	None
Magnesium sulphate....	0.47 lb. lime plus 0.88 lb. soda ash.	1.18 lbs.
Magnesium chloride.....	0.59 lb. lime plus 1.11 lbs. soda ash	1.22 lbs.
Magnesium nitrate.....	0.38 lb. lime plus 0.72 lb. soda ash.	1.15 lbs.
Calcium carbonate.....	1.71 lbs. barium hydrate.....	None
Magnesium carbonate...	4.05 lbs. barium hydrate.....	None
Magnesium sulphate....	1.42 lbs. barium hydrate.....	None
*Calcium sulphate.....	1.26 lbs. barium hydrate.....	None

\* In precipitating the calcium sulphate, there would also be precipitated 0.74 lb. of calcium carbonate or 0.31 lb. of magnesium carbonate, the 1.26 lbs. of barium hydrate performing the work of 0.41 lb. of lime and 0.78 lb. of soda ash, or for reacting on either magnesium or calcium sulphate, 1 lb. of barium hydrate performs the work of 0.33 lb. of lime plus 0.62 lb. of soda-ash, and the lime treatment can be correspondingly reduced.

Barium hydrate has no advantage over lime as a reagent to precipitate the carbonates of lime and magnesia and should not be considered except in connection with the treating of water containing calcium sulphate.

## HYDRAULICS — FLOW OF WATER.

**Formulae for Discharge of Water through Orifices and Weirs.** — For rectangular or circular orifices, with the head measured from center of the orifice to the surface of the still water in the feeding reservoir:

$$Q = C \sqrt{2gH} \times a. \quad (1)$$

For weirs with no allowance for increased head due to velocity of approach:

$$Q = C^{2/3} \sqrt{2gH} \times LH. \quad (2)$$

For rectangular and circular or other shaped vertical or inclined orifices: formula based on the proposition that each successive horizontal layer of water passing through the orifice has a velocity due to its respective head:

$$Q = cL^{2/3} \sqrt{2g} \times (\sqrt{H_b^3} - \sqrt{H_t^3}). \quad (3)$$

For rectangular vertical weirs:

$$Q = c^{2/3} \sqrt{2gH} \times Lh. \quad (4)$$

$Q$  = quantity of water discharged in cubic feet per second;  $C$  = approximate coefficient for formulas (1) and (2);  $c$  = correct coefficient for (3) and (4).

Values of the coefficients  $c$  and  $C$  are given below.

$g = 32.16$ ;  $\sqrt{2g} = 8.02$ ;  $H$  = head in feet measured from center of orifice to level of still water;  $H_b$  = head measured from bottom of orifice;  $H_t$  = head measured from top of orifice;  $h = H$ , corrected for velocity of approach,  $V_a = H + 1.33 V_a^2 / 2g$  for weirs with no end contraction, and  $H + 1.4 V_a^2 / 2g$  for weirs with end contraction;  $a$  = area in square feet;  $L$  = length in feet.





## HYDRAULIC FORMULÆ. — FLOW OF WATER IN OPEN AND CLOSED CHANNELS.

**Flow of Water in Pipes.** — The quantity of water discharged through a pipe depends on the "head"; that is, the vertical distance between the level surface of still water in the chamber at the entrance end of the pipe and the level of the center of the discharge end of the pipe; also upon the length of the pipe, upon the character of its interior surface as to smoothness, and upon the number and sharpness of the bends; but it is independent of the position of the pipe, as horizontal, or inclined upwards or downwards.

The head, instead of being an actual distance between levels, may be caused by pressure, as by a pump, in which case the head is calculated as a vertical distance corresponding to the pressure, 1 lb. per sq. in. = 2.309 ft. head, or 1 ft. head = 0.433 lb. per sq. in.

The total head operating to cause flow is divided into three parts: 1. The *velocity-head*, which is the height through which a body must fall *in vacuo* to acquire the velocity with which the water flows into the pipe =  $v^2 \div 2g$ , in which  $v$  is the velocity in ft. per sec. and  $2g = 64.32$ ; 2. the *entry-head*, that required to overcome the resistance to entrance to the pipe. With sharp-edged entrance the entry-head = about  $1/2$  the velocity-head; with smooth rounded entrance the entry-head is inappreciable; 3. the *friction-head*, due to the frictional resistance to flow within the pipe.

In ordinary cases of pipes of considerable length the sum of the entry and velocity heads required scarcely exceeds 1 foot. In the case of long pipes with low heads the sum of the velocity and entry heads is generally so small that it may be neglected.

### General Formula for Flow of Water in Pipes or Conduits.

Mean velocity in ft. per sec. =  $c \sqrt{\text{mean hydraulic radius} \times \text{slope}}$

Do. for pipes running full =  $c \sqrt{\frac{\text{diameter}}{4} \times \text{slope}}$ ,

in which  $c$  is a coefficient determined by experiment. (See pages following.)

The mean hydraulic radius =  $\frac{\text{area of wet cross-section}}{\text{wet perimeter}}$ .

In pipes running full, or exactly half full, and in semicircular open channels running full it is equal to  $1/4$  diameter.

The slope = the head (or pressure expressed as a head, in feet)

$\div$  length of pipe measured in a straight line from end to end.

In open channels the slope is the actual slope of the surface, or its fall per unit of length, or the sine of the angle of the slope with the horizon.

**Chezy's Formula:**  $v = c \sqrt{r} \sqrt{s} = c \sqrt{rs}$ ;  $r$  = mean hydraulic radius,  $s$  = slope = head  $\div$  length,  $v$  = velocity in feet per second, all dimensions in feet.

**Quantity of Water Discharged.** — If  $Q$  = discharge in cubic feet per second and  $a$  = area of channel,  $Q = av = ac \sqrt{rs}$ .

$a \sqrt{r}$  is approximately proportional to the discharge. It is a maximum at  $308^\circ$  of the circumference, corresponding to  $19/20$  of the diameter, and the flow of a conduit  $19/20$  full is about 5 per cent greater than that of one completely filled.

**Values of the Coefficient  $c$ .** (Chiefly condensed from P. J. Flynn on Flow of Water.) — Almost all the old hydraulic formulæ for finding the

mean velocity in open and closed channels have constant coefficients, and are therefore correct for only a small range of channels. They have often been found to give incorrect results with disastrous effects. Ganguillet and Kutter thoroughly investigated the American, French, and other experiments, and they gave as the result of their labors the formula now generally known as Kutter's formula. There are so many varying conditions affecting the flow of water, that all hydraulic formulæ are only approximations to the correct result.

When the surface-slope measurement is good, Kutter's formula will give results seldom exceeding 7 1/2% error, provided the rugosity coefficient of the formula is known for the site. For small open channels Darcy's and Bazin's formulæ, and for cast-iron pipes Darcy's formulæ, are generally accepted as being approximately correct.

**Table giving Fall in Feet per Mile, the Distance on Slope corresponding to 1 Ft. Fall, the Fall in 1000 Ft., the Equivalent Loss in Pressure in Pipes per 1000 Ft. Length; also Values of  $\sqrt{s}$  for Use in the Formula  $v = c \sqrt{rs}$ .**

$s = H \div L =$  sine of angle of slope = fall of water surface ( $H$ ) in any distance ( $L$ ) divided by that distance.

Fall in Feet per Mile.	Slope, 1 Ft. In	Slope, Feet per 1000.	Loss of Pressure per 1000 Feet. Lb. per sq. in.	$\sqrt{s}$	Fall in Feet per Mile.	Slope, 1 Ft. In	Slope, Feet per 1000.	Loss of Pressure per 1000 Feet. Lb. per sq. in.	$\sqrt{s}$
0.25	21120 ft.	0.0473	0.02048	0.00688	20	264 ft.	3.7879	1.640	0.06155
.30	17600	.0568	.02459	.00754	21.12	250	4.0000	1.732	.06325
.40	13200	.0758	.03282	.00870	22	240	4.1667	1.804	.06455
.50	10560	.0947	.04101	.00973	24	220	4.5455	1.968	.06742
.60	8800	.1136	.04919	.01066	26.4	200	5.0000	2.165	.07071
.80	6600	.1515	.06560	.01231	28	188.6	5.3030	2.296	.07282
1	5280	.1894	.08201	.01376	31.68	166.7	6.0000	2.598	.07746
1.056	5000	.2000	.08650	.01414	35.20	150	6.6667	2.887	.08165
1.25	4224	.2367	.1025	.01539	42.24	125	8.0000	3.464	.08944
1.5	3520	.2841	.1230	.01685	44	120	8.3333	3.608	.09129
1.75	3017	.3314	.1435	.01821	48	110	9.0909	3.936	.09535
2	2640	.3788	.1640	.01946	52.8	100	10.000	4.330	.10000
2.5	2112	.4735	.2050	.02176	60	88	11.364	4.913	.10660
2.64	2000	.5000	.2165	.02236	63.36	83.3	12.000	5.196	.10954
3	1760	.5682	.2460	.02384	66	80	12.500	5.413	.11180
3.5	1508	.6631	.2871	.02575	70.4	75	13.333	5.773	.11547
4	1320	.7576	.3280	.02752	79.20	66.7	15.000	6.495	.12247
5	1056	.9470	.4101	.03077	88	60	16.667	7.217	.12910
5.28	1000	1.0000	.4330	.03162	105.6	50	20.000	8.660	.14142
6	880	1.1364	.4921	.03371	120	44	22.727	9.841	.15076
7	754.3	1.3257	.5740	.03642	132	40	25.000	10.83	.15811
8	660	1.5152	.6561	.03893	160	33	30.303	13.12	.17408
9	586.6	1.7044	.7380	.04129	220	24	41.667	18.04	.20412
10	528	1.8939	.8201	.04352	264	20	50.000	21.65	.22361
10.56	500	2.0000	.8660	.04472	330	16	62.500	27.06	.25000
12	440	2.2727	.9841	.04767	440	12	83.333	36.08	.28868
13	406.1	2.4621	1.066	.04962	528	10	100.00	43.30	.31623
14	377.1	2.6515	1.148	.05149	660	8	125.00	54.13	.35355
15	352	2.8409	1.230	.05330	880	6	166.67	72.17	.40825
16	330	3.0303	1.312	.05505	1056	5	200	86.60	.44721
18	293.3	3.4091	1.476	.05839	1320	4	250	108.25	.50000

**Values of  $\sqrt{r}$  for Circular Pipes, Sewers, and Conduits of Different Diameters.**

$r$  = mean hydraulic depth =  $\frac{\text{area}}{\text{perimeter}} = \frac{1}{4}$  diam. for circular pipes running full or exactly half full.

Diam., ft. in.	$\sqrt{r}$ in Feet.	Diam., ft. in.	$\sqrt{r}$ in Feet.	Diam., ft. in.	$\sqrt{r}$ in Feet.	Diam., ft. in.	$\sqrt{r}$ in Feet.
3/8	0.088	2	0.707	4 6	1.061	9	1.500
1/2	.102	2 1	.722	4 7	1.070	9 3	1.521
3/4	.125	2 2	.736	4 8	1.080	9 6	1.541
1	.144	2 3	.750	4 9	1.089	9 9	1.561
1 1/4	.161	2 4	.764	4 10	1.099	10	1.581
1 1/2	.177	2 5	.777	4 11	1.109	10 3	1.601
1 3/4	.191	2 6	.790	5	1.118	10 6	1.620
2	.204	2 7	.804	5 1	1.127	10 9	1.639
2 1/2	.228	2 8	.817	5 2	1.137	11	1.658
3	.251	2 9	.829	5 3	1.146	11 3	1.677
4	.290	2 10	.842	5 4	1.155	11 6	1.696
5	.323	2 11	.854	5 5	1.164	11 9	1.714
6	.354	3	.866	5 6	1.173	12	1.732
7	.382	3 1	.878	5 7	1.181	12 3	1.750
8	.408	3 2	.890	5 8	1.190	12 6	1.768
9	.433	3 3	.901	5 9	1.199	12 9	1.785
10	.456	3 4	.913	5 10	1.208	13	1.803
11	.479	3 5	.924	5 11	1.216	13 3	1.820
1	.500	3 6	.935	6	1.225	13 6	1.837
1 1	.520	3 7	.946	6 3	1.250	14	1.871
1 2	.540	3 8	.957	6 6	1.275	14 6	1.904
1 3	.559	3 9	.968	6 9	1.299	15	1.936
1 4	.577	3 10	.979	7	1.323	15 6	1.968
1 5	.595	3 11	.990	7 3	1.346	16	2.
1 6	.612	4	1.	7 6	1.369	16 6	2.031
1 7	.629	4 1	1.010	7 9	1.392	17	2.061
1 8	.646	4 2	1.021	8	1.414	17 6	2.091
1 9	.661	4 3	1.031	8 3	1.436	18	2.121
1 10	.677	4 4	1.041	8 6	1.458	19	2.180
1 11	.692	4 5	1.051	8 9	1.479	20	2.236

**Kutter's Formula** for measures in feet is

$$v = \left\{ \frac{\frac{1.811}{n} + 41.6 + \frac{0.00281}{s}}{1 + \left( 41.6 + \frac{0.00281}{s} \right) \times \frac{n}{\sqrt{r}}} \right\} \times \sqrt{rs},$$

in which  $v$  = mean velocity in feet per second;  $r = \frac{a}{p}$  = hydraulic mean depth in feet = area of cross-section in square feet divided by wetted perimeter in lineal feet;  $s$  = fall of water-surface ( $h$ ) in any distance ( $l$ ) divided by that distance, =  $\frac{h}{l}$ , = sine of slope;  $n$  = the coefficient of rugosity, depending on the nature of the lining or surface of the channel. If we let the first term of the right-hand side of the equation equal  $c$ , we have Chezy's formula,  $v = c \sqrt{rs} = c \times \sqrt{r} \times \sqrt{s}$ .

**Values of  $n$  in Kutter's Formula.** — The accuracy of Kutter's formula depends, in a great measure, on the proper selection of the coefficient



of roughness  $n$ . Experience is required in order to give the right value to this coefficient, and to this end great assistance can be obtained, in making this selection, by consulting and comparing the results obtained from experiments on the flow of water already made in different channels.

In some cases it would be well to provide for the contingency of future deterioration of channel, by selecting a high value of  $n$ , as, for instance, where a dense growth of weeds is likely to occur in small channels, and also where channels are likely not to be kept in a state of good repair.

The following table, giving the value of  $n$  for different materials, is compiled from Kutter, Jackson, and Hering, and this value of  $n$  applies also in each instance to the surfaces of other materials equally rough.

#### VALUE OF $n$ IN KUTTER'S FORMULA FOR DIFFERENT CHANNELS.

$n = .009$ , well-planed timber, in perfect order and alignment; otherwise, perhaps  $.01$  would be suitable.

$n = .010$ , plaster in pure cement; planed timber; glazed, coated, or enameled stoneware and iron pipes; glazed surfaces of every sort in perfect order.

$n = .011$ , plaster in cement with one-third sand, in good condition; also for iron, cement, and terra-cotta pipes, well joined, and in best order.

$n = .012$ , unplanned timber, when perfectly continuous on the inside; flumes.

$n = .013$ , ashlar and well-laid brickwork; ordinary metal; earthen and stoneware pipe in good condition, but not new; cement and terra-cotta pipe not well jointed nor in perfect order, plaster and planed wood in imperfect or inferior condition; and, generally, the materials mentioned with  $n = .010$ , when in imperfect or inferior condition.

$n = .015$ , second class or rough-faced brickwork; well-dressed stonework; foul and slightly tuberculated iron; cement and terra-cotta pipes, with imperfect joints and in bad order; and canvas lining on wooden frames.

$n = .017$ , brickwork, ashlar, and stoneware in an inferior condition; tuberculated iron pipes; rubble in cement or plaster in good order; fine gravel, well rammed,  $\frac{1}{3}$  to  $\frac{2}{3}$  inch diameter; and, generally, the materials mentioned with  $n = .013$  when in bad order and condition.

$n = .020$ , rubble in cement in an inferior condition; coarse rubble, rough set in a normal condition; coarse rubble set dry; ruined brickwork and masonry; coarse gravel well rammed, from 1 to  $1\frac{1}{3}$  inch diameter; canals with beds and banks of very firm, regular gravel, carefully trimmed and rammed in defective places; rough rubble with bed partially covered with silt and mud; rectangular wooden troughs with battens on the inside two inches apart; trimmed earth in perfect order.

$n = .0225$ , canals in earth above the average in order and regimen.

$n = .025$ , canals and rivers in earth of tolerably uniform cross-section; slope and direction, in moderately good order and regimen, and free from stones and weeds.

$n = .0275$ , canals and rivers in earth below the average in order and regimen.

$n = .030$ , canals and rivers in earth in rather bad order and regimen, having stones and weeds occasionally, and obstructed by detritus.

$n = .035$ , suitable for rivers and canals with earthen beds in bad order and regimen, and having stones and weeds in great quantities.

$n = .05$ , torrents encumbered with detritus.

Kutter's formula has the advantage of being easily adapted to a change in the surface of the pipe exposed to the flow of water, by a change in the value of  $n$ . For cast-iron pipes it is usual to use  $n = .013$  to provide for the future deterioration of the surface.

Reducing Kutter's formula to the form  $v = c \times \sqrt{r} \times \sqrt{s}$ , and taking  $n$ , the coefficient of roughness in the formula,  $= .011, .012, \text{ and } .013$ , and  $s = .001$ , we have the following values of the coefficient  $c$  of different diameters of conduit.

Values of  $c$  in Formula  $v = c \times \sqrt{r} \times \sqrt{s}$  for Metal Pipes and Moderately Smooth Conduits Generally.

By KUTTER'S FORMULA. ( $s=0.001$  or greater.)

Diameter.		$n = .011$	$n = .012$	$n = .013$	Diameter.		$n = .011$	$n = .012$	$n = .013$
ft.	in.	$c =$	$c =$	$c =$	ft.	in.	$c =$	$c =$	$c =$
0	6	87.4	77.5	69.5	8		155.4	141.9	130.4
1		105.7	94.6	85.3	9		157.7	144.1	132.7
1	6	116.1	104.3	94.4	10		159.7	146	134.5
2		123.6	111.3	101.1	11		161.5	147.8	136.2
3		133.6	120.8	110.1	12		163	149.3	137.7
4		140.4	127.4	116.5	14		165.8	152	140.4
5		145.4	132.3	121.1	16		168	154.2	142.1
6		149.4	136.1	124.8	18		169.9	156.1	144.4
7		152.7	139.2	127.9	20		171.6	157.7	146

For circular pipes the hydraulic mean depth  $r$  equals  $1/4$  of the diameter.

According to Kutter's formula the value of  $c$ , the coefficient of discharge, is the same for all slopes greater than 1 in 1000. At a slope of 1 in 5000 the value of  $c$  is slightly lower, and it further decreases as the slope becomes flatter.

The reliability of the values of the coefficient of Kutter's formula for pipes of less than 6 in. diameter is considered doubtful.

Values of  $c$  for Earthen Channels, by Kutter's Formula, for Use in Formula  $v = c \sqrt{rs}$ .

Slope, 1 in	Coefficient of Roughness, $n = .0225$ .					Coefficient of Roughness, $n = .035$ .				
	$\sqrt{r}$ in feet.					$\sqrt{r}$ in feet.				
	0.4	1.0	1.8	2.5	4.0	0.4	1.0	1.8	2.5	4.0
1,000	35.7	62.5	80.3	89.2	99.9	19.7	37.6	51.6	59.3	69.2
1,250	35.5	62.3	80.3	89.3	100.2	19.6	37.6	51.6	59.4	69.4
1,667	35.2	62.1	80.3	89.5	100.6	19.4	37.4	51.6	59.5	69.8
2,500	34.6	61.7	80.3	89.8	101.4	19.1	37.1	51.6	59.7	70.4
3,333	34.	61.2	80.3	90.1	102.2	18.8	36.9	51.6	59.9	71.0
5,000	33.	60.5	80.3	90.7	103.7	18.3	36.4	51.6	60.4	72.2
7,500	31.6	59.4	80.3	91.5	106.0	17.6	35.8	51.6	60.9	73.9
10,000	30.5	58.5	80.3	92.3	107.9	17.1	35.3	51.6	60.5	75.4
15,840	28.5	56.7	80.2	93.9	112.2	16.2	34.3	51.6	62.5	78.6
20,000	27.4	55.7	80.2	94.8	115.0	15.6	33.8	51.5	63.1	80.6

Darcy's Formula for clean iron pipes under pressure is

$$v = \left\{ \frac{rs}{0.00007726 + \frac{0.00000162}{r}} \right\}^{1/2}$$

According to Unwin and other authors Darcy's experiments are represented approximately by the formula

$$v = \sqrt{\frac{64.4}{f} \frac{h}{l} \frac{d}{4}} \text{ feet per second}$$

in which  $f$ , called the "coefficient of friction,"  $= 0.005 \left( 1 + \frac{1}{12d} \right)$ ,  $h$  being the loss of head,  $l$  the length of the pipe,  $h/l$  the slope  $s$ , and  $d/4$  the mean hydraulic radius  $r$ , of the Chezy formula. All the dimensions are in feet.

Darcy's formula, as given by J. B. Francis, for old cast-iron pipe, lined with deposit and under pressure is

$$v = \left( \frac{144d^2s}{0.00082(12d+1)} \right)^{1/2}$$

in which  $d$  = diameter in feet.

Values of  $a\sqrt{r}$  for use in Chezy's Formula,  $Q = ac\sqrt{r}\sqrt{s}$ .  
 $a$  = area in square feet,  $r$  = mean hydraulic radius =  $\frac{1}{4}$  diam. in ft.,  $s$  = sine of slope = head in ft.  $\div$  length  
 $c$  = Chezy coefficient.

Standard Welded Pipe.

Even-sized Pipe.

Nom- inal Size, In.	Inter- nal Diam., In.	Internal Area, Sq. Ft.	$a\sqrt{r}$	Diam., In.	Area, Sq. Ft.	$a\sqrt{r}$	Diam., In.	Area, Sq. Ft.	$a\sqrt{r}$	Diam., Ft. In.	Area, Sq. Ft.	$a\sqrt{r}$
1/8	0.269	0.0003958	0.00002955	1/4	0.0003409	0.00002460	11	0.6600	0.3159	6	28.274	34.63
1/4	0.364	0.007222	0.0006293	3/8	0.007670	0.0006779	11 1/2	0.7213	0.3531	6	33.183	42.30
3/8	0.493	0.01326	0.001344	1/2	0.01364	0.001392	12	0.7854	0.3927	7	38.485	50.91
1/2	0.622	0.02111	0.002402	5/8	0.02131	0.002431	13	0.9218	0.4797	7	44.179	60.49
3/4	0.824	0.03701	0.004824	3/4	0.03068	0.003835	14	1.069	0.5773	8	50.265	71.09
1	1.049	0.06000	0.008873	1	0.05454	0.007872	15	1.227	0.6860	8	56.745	82.72
1 1/4	1.380	0.1038	0.01761	1 1/4	0.08522	0.01375	16	1.396	0.8061	9	63.617	95.43
1 1/2	1.610	0.1414	0.02589	1 1/2	0.1227	0.02169	17	1.576	0.9381	9	70.882	109.2
2	2.067	0.2330	0.04836	1 3/4	0.1670	0.03189	18	1.767	1.082	10	78.540	124.2
2 1/2	2.469	0.3325	0.07541	2	0.2182	0.04453	19	1.969	1.239	10	86.590	140.3
3	3.068	0.5134	0.1298	2 1/4	0.2761	0.05978	20	2.182	1.408	11	95.033	157.6
3 1/2	3.548	0.6865	0.1867	2 1/2	0.3409	0.07780	21	2.405	1.591	11	103.87	176.1
4	4.026	0.8840	0.2560	2 3/4	0.4125	0.09873	22	2.640	1.787	12	113.10	195.9
4 1/2	4.506	1.107	0.3393	3	0.4909	0.1227	23	2.885	1.997	12	122.72	216.9
5	5.047	1.389	0.4527	3 1/2	0.6681	0.1804	24	3.142	2.221	13	132.73	239.3
6	6.065	2.006	0.7132	4	0.8726	0.2519	26	3.687	2.714	13	143.14	263.0
7	7.023	2.690	1.030	4 1/2	1.104	0.3382	28	4.276	3.266	14	153.94	288.0
8	7.981	3.474	1.416	5	1.364	0.4401	30	4.909	3.881	14	165.13	314.4
9	8.941	4.360	1.882	5 1/2	1.650	0.5585	32	5.585	4.560	15	176.71	342.2
10	10.020	5.476	2.502	6	1.963	0.6942	34	6.305	5.307	15	188.69	371.4
11	11.000	6.600	3.159	6 1/2	2.304	0.8480	36	7.069	6.122	16	201.06	402.1
12	12.000	7.854	3.927	7	2.673	1.021	38	7.876	7.008	16	213.82	434.3
13	13.250	9.575	5.031	7 1/2	3.068	1.213	40	8.726	7.966	17	226.98	467.9
14	14.250	1.108	6.034	8	3.491	1.425	42	9.621	9.000	17	240.53	503.1
15	15.250	1.268	7.150	8 1/2	3.941	1.658	44	10.559	10.111	18	254.47	539.8
17 O.D.	16.214	1.434	8.334	9	4.418	1.913	48	12.566	12.57	18	268.80	578.1
18 O.D.	17.182	1.610	9.634	9 1/2	4.922	2.190	54	15.904	16.87	19	283.53	617.9
20 O.D.	19.182	2.007	1.269	10	5.454	2.490	60	19.635	21.95	19	298.65	659.4
				10 1/2	6.013	2.812	66	23.758	27.86	20	314.16	702.5



The relation of the value of  $c$  in Chezy's formula  $V = c \sqrt{rs}$  to the value of the coefficient of friction  $f$  is  $c = \sqrt{2g/f}$ .

$f = .0035$	$.0040$	$.0045$	$.0050$	$.0055$	$.0060$	$.0065$
$c = 135.5$	$127.8$	$119.6$	$113.4$	$108.1$	$103.5$	$99.4$
$f = .0070$	$.0075$	$.0080$	$.0090$	$.010$	$.011$	$.012$
$c = 95.8$	$92.6$	$89.7$	$84.5$	$80.2$	$76.5$	$73.2$

$c = 60$	$70$	$80$	$90$	$100$	$110$	$120$	$130$	$140$	$150$
$f = .018$	$.013$	$.010$	$.008$	$.0064$	$.0053$	$.0045$	$.0038$	$.0033$	$.0029$

Unwin derives the following equations from the Darcy formula:

- Velocity, ft. per sec. . . . .  $v = 4.012 \sqrt{dh/(fl)} = 1.273 Q/d^2 = c \sqrt{d/4} \times \sqrt{s}$ .
- Diameter, ft. . . . .  $d = 0.0622 fvl/h = 1.128 \sqrt{Q/v}$ .
- Quantity, cu. ft. per sec.  $Q = 3.149 \sqrt{hd^5/fl}$ .
- Head, ft. . . . .  $h = 0.1008 fQ^2/d^5$ .

Rough preliminary calculations may be made by the following approximate formulæ. They are least accurate for small pipes.  $s = \text{slope, } = h/l$ .

New and clean pipes.	Old and incrustated pipes.
$v = 56 \sqrt{ds}$ .	$v = 40 \sqrt{ds}$ .
$Q = 44 \sqrt{d^3s}$ .	$Q = 31.4 \sqrt{d^3s}$ .
$d = 0.22 \sqrt[5]{Q^2/s}$ .	$d = 0.252 \sqrt[5]{Q^2/s}$ .

Weisbach gives  $f = 0.00644$ , which Unwin says is possibly too small for tubes of small bore, and he gives  $f = 0.006$  to  $0.01$  for 4-in. tubes and  $f = 0.0084$  to  $0.012$  for 2-in. tubes. Another formula by Weisbach is

$$h = \left( 0.0144 + \frac{0.01716}{\sqrt{v}} \right) \frac{l}{d} \frac{v^2}{2g}$$

William Cox (*Amer. Mach.*, Dec. 28, 1893) gives a simpler formula which gives almost identical results:

$$H = \text{friction-head in feet} = \frac{L}{d} \frac{4V^2 + 5V - 2}{1200} \dots \dots \dots (1)$$

$$\frac{Hd}{L} = \frac{4V^2 + 5V - 2}{1200} \dots \dots \dots (2)$$

In this formula  $H$  and  $L$  are in feet,  $d$  in inches, and  $V$  in feet per second.

**Values of the Coefficient of Friction.** Unwin's "Hydraulics" gives values of  $f$ , based on Darcy's experiments, as follows: Clean and smooth pipes,  $f = 0.005 [1 + 1/(12d)]$ . Incrustated pipes,  $f = 0.01 [1 + 1/(12d)]$ . In 1886 Unwin examined all the more carefully made experiments on flow in pipes, including those of Darcy, classifying them according to the quality and condition of their surfaces, and showing the relation of the value of  $f$  to both diameter and velocity. The results agree fairly closely with the following values,  $f = a (1 + \beta/d)$ .

Kind of Pipe.	Values of $a$ for Velocities in ft. per Second.				Values of $\beta$
	1-2	2-3	3-4	4-5	
Drawn wrought iron. . . . .	.00375	.00322	.00297	.00275	0.37
Asphalted cast iron. . . . .	.00492	.00455	.00432	.00415	0.20
Clean cast iron. . . . .	.00405	.00395	.00387	.00382	0.28
Incrusted cast iron at all velocities $a = 0.00855$					0.26

From the experiments of Clemens Herschel, 1892-6, on clean steel riveted pipes, Unwin derives the following values of  $f$  for different velocities.

Ft. per sec. . . . .	1	2	3	4	5	6
48-in. pipe, av. of 2. . . . .	.0066	.0060	.0057	.0055	.0055	.0055
42-in. pipe, av. of 2. . . . .	.0067	.0058	.0054	.0054	.0054	.0054
36-in. pipe. . . . .	.0087	.0071	.0060	.0053	.0047	.0042

Unwin attributes the anomalies in this table to errors of observation. In comparing the results with those on cast-iron pipes, the roughness of the rivet heads and joints must be considered, and the resistance can only be determined by direct experiment on riveted pipes.

Two portions of the 48-in. main were tested after being four years in use, and the coefficients derived from them differ remarkably.

Ft. per sec. ....	1	2	3	4	5	6
Upper part .....	.0106	.0080	.0075	.0073	.0072	.0072
Lower part .....	.0068	.0060	.0058	.0060	.0060	.0060

Marx, Wing, and Hopkins in 1897 and 1899 made gaugings on a 6-ft. main, part of which was of riveted steel and part of wood staves. (*Trans. A. S. C. E.*, xl, 471, and xlv, 34.) From these tests Unwin derives the following values of  $f$ .

Ft. per sec.	1	1.5	2	2.5	3	4	5	5.5
Steel pipe:								
1897... $f =$	.0053	.0052	.0053	.0055	.0055	.0052	.....	.....
1899... $f =$	.0097	.0076	.0067	.0063	.0061	.0060	.0058	.0058

Wood staves:

1897... $f =$	.0064	.0053	.0048	.....	.0043	.0041	.....	.....
1899... $f =$	.0048	.0046	.0045	.....	.0044	.0043	.0043	.0043

Freeman's experiments on fire hose pipes (*Trans. A. S. C. E.*, xxi, 303) give the following values of  $f$ .

Velocity, ft. per sec. ....	4	6	10	15	20
Unlined canvas .....	.0095	.0095	.0093	.0088	.0085
Rough rubber-lined cotton .....	.0078	.0078	.0078	.0075	.0073
Smooth rubber-lined cotton .....	.0060	.0058	.0055	.0048	.0045

**The Resistance at the Inlet of a Pipe** is equal to the frictional resistance of a straight pipe whose length is  $l_0 = (1 + f_0) d + 4 f$ . Values of  $f_0$  are: (A) for end of pipe flush with reservoir wall, 0.5; (B) pipe entering wall, straight edges, 0.56; (C) pipe entering wall, sharp edges, 1.30; (D) bell-mouthed inlet, 0.02 to 0.05. Values of  $l_0/d$  are for

$f = 0.005$	A, 53	B, 75	C, 78	D, 115
0.010	26	38	39	58

Multiplying these figures by  $d$  gives the length of straight pipe to be added to the actual length to allow for the inlet resistance. In long lengths of pipe the relative value of this length is so small that it may be neglected in practical calculations. — (Unwin.)

**Loss of Head in Pipe by Friction.** — Loss of head by friction in each 100 feet in length of riveted pipe when discharging the following quantities of water per minute (Pelton Water-wheel Co.).

$V$  = velocity in feet per second;  $h$  = loss of head in feet;  $Q$  = discharge in cubic feet per minute.

V	Inside Diameter of Pipe in Inches.											
	7		8		9		10		11		12	
	$h$	$Q$	$h$	$Q$	$h$	$Q$	$h$	$Q$	$h$	$Q$	$h$	$Q$
2.0	0.338	32.0	0.296	41.9	0.264	53	0.237	65.4	0.216	79.2	0.198	94.2
3.0	0.698	48.1	0.611	62.8	0.544	79.5	0.488	98.2	0.444	119	0.407	141
4.0	1.175	64.1	1.027	83.7	0.913	106	0.822	131	0.747	158	0.685	188
5.0	1.76	80.2	1.54	105	1.37	132	1.23	163	1.122	198	1.028	235
6.0	2.46	96.2	2.15	125	1.92	159	1.71	196	1.56	237	1.43	283
7.0	3.26	112.0	2.85	146	2.52	185	2.28	229	2.07	277	1.91	330

V	13 in.		14 in.		15 in.		16 in.		18 in.		20 in.	
	$h$	$Q$	$h$	$Q$	$h$	$Q$	$h$	$Q$	$h$	$Q$	$h$	$Q$
2.0	0.183	110	0.169	128	0.158	147	0.147	167	0.132	212	0.119	262
3.0	.375	166	.349	192	.325	221	.306	251	.271	318	.245	393
4.0	.632	221	.587	256	.548	294	.513	335	.456	424	.410	523
5.0	.949	276	.881	321	.822	368	.770	419	.685	530	.617	654
6.0	1.325	332	1.229	385	1.148	442	1.076	502	.957	636	.861	785
7.0	1.75	387	1.63	449	1.52	515	1.43	586	1.27	742	1.143	916

## Loss of Head (Continued).

V	Diameter of Pipe in Inches.											
	22 in.		24 in.		26 in.		28 in.		30 in.		36 in.	
	h	Q	h	Q	h	Q	h	Q	h	Q	h	Q
2.0	0.108	316	0.098	377	0.091	442	0.084	513	0.079	589	0.066	848
3.0	.222	475	.204	565	.188	663	.174	770	.163	883	.135	1273
4.0	.373	633	.342	754	.315	885	.293	1026	.273	1178	.228	1697
5.0	.561	792	.513	942	.474	1106	.440	1283	.411	1472	.342	2121
6.0	.782	950	.717	1131	.662	1327	.615	1539	.574	1767	.479	2545
7.0	1.040	1109	.953	1319	.879	1548	.817	1796	.762	2061	.636	2868

This table is based on Cox's reconstruction of Weisbach's formula, using the denominator 1000 instead of 1200, to be on the safe side, allowing 20% for the loss of head due to the laps and rivet-heads in the pipe.

**EXAMPLE.** — Given 200 ft. head and 600 ft. of 11-inch pipe, carrying 119 cubic feet of water per minute. To find effective head: In right-hand column, under 11-inch pipe, find 119 cubic ft.; opposite this will be found the loss by friction in 100 ft. of length for this amount of water, which is 0.444. Multiply this by the number of hundred feet of pipe, which is 6, and we have 2.66 ft., which is the loss of head. Therefore the effective head is  $200 - 2.66 = 197.34$ .

**EXPLANATION.** — The loss of head by friction in a pipe depends not only upon diameter and length, but upon the quantity of water passed through it. The head or pressure is what would be indicated by a pressure-gauge attached to the pipe near the wheel. Readings of gauge should be taken while the water is flowing from the nozzle.

To reduce heads in feet to pressure in pounds multiply by 0.433. To reduce pounds pressure to feet multiply by 2.309.

**Exponential Formulæ. Williams and Hazen's Tables.** — From Chezy's formula,  $v = c \sqrt{rs}$ , it would appear that the velocity varies as the square root of the head, or that the head varies as the square of the velocity; this is not true, however, for  $c$  is not a constant, but a variable, depending on both  $r$  and  $s$ . Hazen and Williams, as a result of a study of the best records of experiments and plotting them on logarithmic ruled paper, found an exponential formula  $v = cr^{0.63} s^{0.54}$ , in which the coefficient  $c$  is practically independent of the diameter and the slope, and varies only with the condition of the surface. In order to equalize the numerical value of  $c$  to that of the  $c$  in the Chezy formula, at a slope of 0.001, they added the factor  $0.001^{-0.04}$  to the formula, so that the working formula of Hazen and Williams is

$$v = cr^{0.63} s^{0.54} 0.001^{-0.04} = 1.318 cr^{0.63} s^{0.54}.$$

**APPROXIMATE VALUES OF C IN THE HAZEN & WILLIAMS FORMULA.**

- (a) 140 for the very best cast-iron pipe, laid straight and when new; for very smooth and clean masonry conduits;
- (b) 130 for straight lead, copper, brass, tin, and glass pipes.
- (c) 120 for good new cast-iron pipe, and other pipes under (a) when not quite smooth.\*
- (d) 110 for cast-iron pipe 5 years old, for smooth new iron pipes, smooth wooden stave pipes and ordinary masonry conduits.
- (e) 110 for new riveted steel pipe, for vitrified pipe, and for cast-iron pipe 10 years old.
- (f) 100 for ordinary iron pipes, 14 to 20 years old, for riveted steel pipe 10 years old, and for brick sewers.
- (g) 80 for old iron pipes, and for very rough cast-iron pipes over 60 inches diameter.
- (g) 60 down to 40, for very rough pipes, the lower figure for the smaller diameters.

\* 130 may also be used for straight lead, tin, and drawn copper pipes. Computations of the exponential formula are made by logarithms, or by the Hazen-Williams hydraulic slide rule. On logarithmic ruled paper values of  $v$  for different values of  $c$ ,  $r$  and  $s$  may be plotted in straight lines. (See "Hydraulic Tables," by Williams and Hazen, John Wiley & Sons.)



Values of Coefficient *K* for Reducing the Hazen and Williams Formula to the Style of Chezy's Formula  $v = c \sqrt{r} \sqrt{s}$

Diam., Ft.In.	Slope = Head ÷ Length of Pipe.										
	0.0005	0.001	0.002	0.003	0.005	0.01	0.02	0.04	0.06	0.10	0.20
0 1/2	0.5374	0.5525	0.5680	0.5773	0.5892	0.6058	0.6228	0.6403	0.6508	0.6642	0.6829
0 1	.5880	.6046	.6216	.6317	.6448	.6629	.6815	.7007	.7122	.7269	.7473
0 2	.6435	.6616	.6802	.6913	.7056	.7254	.7458	.7667	.7793	.7954	.8177
0 4	.7042	.7240	.7443	.7565	.7721	.7938	.8161	.8390	.8528	.8704	.8949
0 8	.7706	.7922	.8145	.8278	.8449	.8686	.8931	.9182	.9332	.9525	.9792
0 12	.8123	.8351	.8586	.8726	.8906	.9157	.9414	.9679	.9837	1.004	1.032
2	.8889	.9138	.9395	.9549	.9746	1.002	1.030	1.059	1.076	1.099	1.130
4	.9727	1.000	1.028	1.045	1.067	1.096	1.127	1.159	1.178	1.202	1.236
8	1.064	1.094	1.125	1.143	1.167	1.200	1.234	1.268	1.289	1.316	1.353
12	1.122	1.154	1.186	1.205	1.230	1.265	1.300	1.337	1.359	1.387	1.426
16	1.165	1.197	1.231	1.251	1.277	1.313	1.350	1.388	1.411	1.440	1.480
20	1.199	1.233	1.267	1.288	1.315	1.352	1.390	1.429	1.452	1.482	1.524

H. & W. Formula:  $V = 1.318 cr^{0.63} s^{0.54} = Kc \sqrt{r} \sqrt{s}$

$$K = \frac{1.318 cr^{0.63} s^{0.54}}{cr^{0.50} s^{0.50}} = 1.318 \left(\frac{D}{4}\right)^{0.13} s^{0.04}$$

**Short Formulæ.** E. Sherman Gould, *Eng. News*, Sept. 6, 1900, shows that Darcy's formulæ for cast-iron pipes may be reduced to the following approximate forms, in which *h* is loss of head or drop of hydraulic grade line in feet per 1000, *d* in ft., *v* in ft. per sec., *Q* in cu. ft. per sec.

- |                       |   |
|-----------------------|---|
| 8 in. to 48 in. diam. | { Rough, $Q^2 = hd^5$ ; $v = 1.27 \sqrt{dh}$ .      |
|                       | { Smooth, $Q^2 = 2hd^5$ ; $v = 1.80 \sqrt{dh}$ .    |
| 3 to 6 in. diam.      | { Rough, $Q^2 = 0.785hd^5$ ; $v = 1.13 \sqrt{dh}$ . |
|                       | { Smooth, $Q^2 = 1.57hd^5$ ; $v = 1.60 \sqrt{dh}$ . |

**FLOW OF WATER—EXPERIMENTS AND TABLES.**

The Flow of Water through New Cast-iron Pipe was measured by S. Bent Russell, of the St. Louis, Mo., Water-works. The pipe was 12 inches in diameter, 1631 feet long, and laid on a uniform grade from end to end. Under an average total head of 3.36 feet the flow was 43,200 cubic feet in seven hours; under an average head of 3.37 feet the flow was the same; under an average total head of 3.41 feet the flow was 46,700 cubic feet in 8 hours and 35 minutes. Making allowance for loss of head due to entrance and to curves, it was found that the value of *c* in the formula  $v = c \sqrt{rs}$  was from 88 to 93. (*Eng'g Record*, April 14, 1894.)

**Flow of Water in a 20-inch Pipe 75,000 Feet Long.** — A comparison of experimental data with calculations by different formulæ is given by Chas. B. Brush, *Trans. A. S. C. E.*, 1888. The pipe experimented with was that supplying the city of Hoboken, N. J.

**RESULTS OBTAINED BY THE HACKENSACK WATER CO., FROM 1882-1887, IN PUMPING THROUGH A 20-IN. CAST-IRON MAIN 75,000 FEET LONG.**

Pressure in lbs. per sq. in. at pumping-station:	95	100	105	110	115	120	125	130
Total effective head in feet:	55	66	77	89	100	112	123	135
Discharge in U. S. gallons in 24 hours, 1 = 1000:	2,848	3,165	3,354	3,566	3,804	3,904	4,116	4,255
Theoretical discharge by Darcy's formula:	2,743	3,004	3,244	3,488	3,699	3,915	4,102	4,297
Actual velocity in main in feet per second:	2.00	2.24	2.36	2.52	2.68	2.76	2.92	3.00

**Flow of Water in Circular Pipes, Sewers, etc., Flowing Full.  
Based on Kutter's Formula, with  $n = 0.013$ .**

Discharge in cubic feet per second.

Diameter.	Slope, or Head Divided by Length of Pipe.							
	1 in 40	1 in 70	1 in 100	1 in 200	1 in 300	1 in 400	1 in 500	1 in 600
5 in.	0.456	0.344	0.288	0.204	0.166	0.144	0.137	0.118
6 "	0.762	0.574	0.482	0.341	0.278	0.241	0.230	0.197
7 "	1.17	0.889	0.744	0.526	0.430	0.372	0.355	0.304
8 "	1.70	1.29	1.08	0.765	0.624	0.54	0.516	0.441
9 "	2.37	1.79	1.50	1.06	0.868	0.75	0.717	0.613
s =								
10 in.	1 in 60	1 in 80	1 in 100	1 in 200	1 in 300	1 in 400	1 in 500	1 in 600
11 "	2.59	2.24	2.01	1.42	1.16	1.00	0.90	0.82
12 "	3.39	2.94	2.63	1.86	1.52	1.31	1.17	1.07
13 "	4.32	3.74	3.35	2.37	1.93	1.67	1.5	1.37
14 "	5.38	4.66	4.16	2.95	2.40	2.08	1.86	1.70
15 "	6.60	5.72	5.15	3.62	2.95	2.57	2.29	2.09
s =								
15 in.	1 in 100	1 in 200	1 in 300	1 in 400	1 in 500	1 in 600	1 in 700	1 in 800
16 "	6.18	4.37	3.57	3.09	2.77	2.52	2.34	2.19
18 "	7.38	5.22	4.26	3.69	3.30	3.01	2.79	2.61
20 "	10.21	7.22	5.89	5.10	4.56	4.17	3.86	3.61
22 "	13.65	9.65	7.88	6.82	6.10	5.57	5.16	4.83
24 "	17.71	12.52	10.22	8.85	7.92	7.23	6.69	6.26
s =								
2 ft.	1 in 200	1 in 400	1 in 600	1 in 800	1 in 1000	1 in 1250	1 in 1500	1 in 1800
2 ft. 2 in.	15.88	11.23	9.17	7.94	7.10	6.35	5.80	5.29
2 " 4 "	19.73	13.96	11.39	9.87	8.82	7.89	7.20	6.58
2 " 6 "	24.15	17.07	13.94	12.07	10.80	9.66	8.82	8.05
2 " 8 "	29.08	20.56	16.79	14.54	13.00	11.63	10.62	9.69
2 " 10 "	34.71	24.54	20.04	17.35	15.52	13.88	12.67	11.57
s =								
2 ft. 10 in.	1 in 500	1 in 750	1 in 1000	1 in 1250	1 in 1500	1 in 1750	1 in 2000	1 in 2500
3 "	25.84	21.10	18.27	16.34	14.92	13.81	12.92	11.55
3 " 2 in.	30.14	24.61	21.31	19.06	17.40	16.11	15.07	13.48
3 " 4 "	34.90	28.50	24.68	22.07	20.15	18.66	17.45	15.61
3 " 6 "	40.08	32.72	28.34	25.35	23.14	21.42	20.04	17.93
3 " 8 "	45.66	37.28	32.28	28.87	26.36	24.40	22.83	20.41
s =								
3 ft. 8 in.	1 in 500	1 in 750	1 in 1000	1 in 1250	1 in 1500	1 in 1750	1 in 2000	1 in 2500
3 " 10 "	51.74	42.52	36.59	32.72	29.87	27.66	25.87	23.14
4 "	58.36	47.65	41.27	36.91	33.69	31.20	29.18	26.10
4 " 2 in.	65.47	53.46	46.30	41.41	37.80	34.50	32.74	29.28
4 " 4 in.	89.75	73.28	63.47	56.76	51.82	47.97	44.88	40.14
4 " 6 in.	118.9	97.09	84.08	75.21	68.65	63.56	59.46	53.18
s =								
5 ft. 6 in.	1 in 750	1 in 1000	1 in 1500	1 in 2000	1 in 2500	1 in 3000	1 in 3500	1 in 4000
6 "	125.2	108.4	88.54	76.67	68.58	62.60	57.96	54.21
6 " 6 "	157.8	136.7	111.6	96.66	86.45	78.92	73.07	68.35
7 "	195.0	168.8	137.9	119.4	106.8	97.49	90.26	84.43
7 " 6 "	237.7	205.9	168.1	145.6	130.2	118.8	110.00	102.9
8 "	285.3	247.1	201.7	174.7	156.3	142.6	132.1	123.5
s =								
8 ft.	1 in 1500	1 in 2000	1 in 2500	1 in 3000	1 in 3500	1 in 4000	1 in 4500	1 in 5000
8 " 6 in.	239.4	207.3	195.4	169.3	156.7	146.6	138.2	131.1
9 "	281.1	243.5	217.8	198.8	184.0	172.2	162.3	154.0
9 " 6 "	327.0	283.1	253.3	231.2	214.0	200.2	188.7	179.1
10 "	376.9	326.4	291.9	266.5	246.7	230.8	217.6	206.4
10 " 6 in.	431.4	373.6	334.1	305.0	282.4	264.2	249.1	236.3

For U. S. gallons multiply the figures in the table by 7.4805.

For a given diameter the quantity of flow varies as the square root of the sine of the slope. From this principle the flow for other slopes than those given in the table may be found. Thus, what is the flow for a

pipe 8 feet diameter, slope 1 in 125? From the table take  $Q = 207.3$  for slope 1 in 2000. The given slope 1 in 125 is to 1 in 2000 as 16 to 1, and the square root of this ratio is 4 to 1. Therefore the flow required is  $207.3 \times 4 = 829.2$  cu. ft.

**Circular Pipes, Conduits, etc., Flowing Full.**

Values of the factor  $ac\sqrt{r}$  in the formula  $Q = ac\sqrt{r} \times \sqrt{s}$  corresponding to different values of the coefficient of roughness,  $n$ . (Based on Kutter's formula.)

Diam., Ft. In.	Value of $ac\sqrt{r}$ .					
	$n=.010$ .	$n=.011$ .	$n=.012$ .	$n=.013$ .	$n=.015$ .	$n=.017$ .
2	307.6	274.50	247.33	224.63	188.77	164
2 3	421.9	377.07	340.10	309.23	260.47	223.9
2 6	559.6	500.78	452.07	411.27	347.28	299.3
2 9	722.4	647.18	584.90	532.76	451.23	388.8
3	911.8	817.50	739.59	674.09	570.90	493.3
3 3	1128.9	1013.1	917.41	836.69	709.56	613.9
3 6	1374.7	1234.4	1118.6	1021.1	866.91	750.8
3 9	1652.1	1484.2	1345.9	1229.7	1045	906
4	1962.8	1764.3	1600.9	1463.9	1245.3	1080.7
4 6	2682.1	2413.3	2193	2007	1711.4	1487.3
5	3543	3191.8	2903.6	2659	2272.7	1977
5 6	4557.8	4111.9	3742.7	3429	2934.8	2557.2
6	5731.5	5176.3	4713.9	4322	3702.3	3232.5
6 6	7075.2	6394.9	5825.9	5339	4588.3	4010
7	8595.1	7774.3	7087	6510	5591.6	4893.2
7 6	10296	9318.3	8501.8	7814	6717	5884.3
8	12196	11044	10083	9272	7978.3	6995.3
8 6	14298	12954	11832	10889	9377.9	8226.7
9	16604	15049	13751	12663	10917	9580
9 6	19118	17338	15847	14597	12594	11061
10	21858	19834	18134	16709	14426	12678
10 6	24823	22534	20612	18996	16412	14434
11	28020	25444	23285	21464	18555	16333
11 6	31482	28593	26179	24139	20879	18395
12	35156	31937	29254	26981	23352	20584
12 6	39104	35529	32558	30041	26012	22938
13	43307	39358	36077	33301	28850	25451
13 6	47751	43412	39802	36752	31860	28117
14	52491	47739	43773	40432	35073	30965
14 6	57496	52308	47969	44322	38454	33975
15	62748	57103	52382	48413	42040	37147
16	74191	67557	62008	57343	49823	44073
17	86769	79050	72594	67140	58387	51669
18	100617	91711	84247	77932	67839	60067
19	115769	105570	96991	89759	78201	69301
20	132133	120570	110905	102559	89423	79259

**Flow of Water in Pipes from 3/8 Inch to 12 Inches Diameter for a Uniform Velocity of 100 Ft. per Min.**

Diam. in In.	Area Sq. Ft.	Cu. Ft. per Min.	U. S. Gallons per Min.	Diam. in In.	Area Sq. Ft.	Cu. Ft. per Min.	U. S. Gallons per Min.
3/8	.00077	0.077	.57	4	.0873	8.73	65.28
1/2	.00136	0.136	1.02	5	.136	13.6	102.00
3/4	.00307	0.307	2.30	6	.196	19.6	146.88
1	.00545	0.545	4.08	7	.267	26.7	199.92
1 1/4	.00852	0.852	6.38	8	.349	34.9	261.12
1 1/2	.01227	1.227	9.18	9	.442	44.2	330.48
1 3/4	.01670	1.670	12.50	10	.545	54.5	408.00
2	.02182	2.182	16.32	11	.660	66.0	493.68
2 1/2	.0341	3.41	25.50	12	.785	78.5	587.52
3	.0491	4.91	36.72				



### Flow of Water in Circular Pipes, Conduits, etc., Flowing under Pressure.

Based on Darcy's formulæ for the flow of water through cast-iron pipes. With comparison of results obtained by Kutter's formula, with  $n = 0.013$ . (Condensed from Flynn on Water Power.)

Values of  $a$ , and also the values of the factors  $c\sqrt{r}$  and  $ac\sqrt{r}$  for use in the formulæ  $Q = av$ ;  $v = c\sqrt{r} \times \sqrt{s}$ , and  $Q = ac\sqrt{r} \times \sqrt{s}$ .

$Q$  = discharge in cubic feet per second,  $a$  = area in square feet,  $v$  = velocity in feet per second,  $r$  = mean hydraulic depth,  $\frac{1}{4}$  diam. for pipes running full,  $s$  = sine of slope.

(For values of  $\sqrt{s}$  see page 729.)

Size of Pipe.		Clean Cast-iron Pipes.		Value of $ac\sqrt{r}$ by Kutter's Formula, when $n = .013$ .	Old Cast-iron Pipes Lined with Deposit.	
$d$ = diam. in ft. in.	$a$ = area in square feet.	For Velocity, $c\sqrt{r}$ .	For Discharge, $ac\sqrt{r}$ .		For Velocity, $c\sqrt{r}$ .	For Discharge, $ac\sqrt{r}$ .
2		3.142	78.80	224.63	52.961	166.41
2	2	3.687	28.15		55.258	203.74
2	4	4.276	85.39		57.436	245.60
2	6	4.909	88.39	411.37	59.455	291.87
2	8	5.585	91.51		61.55	343.8
2	10	6.305	94.40		63.49	400.3
3		7.068	97.17	674.09	65.35	461.9
3	2	7.875	99.93		67.21	529.3
3	4	8.726	102.6		69	602
3	6	9.621	105.1	1021.1	70.70	680.2
3	8	10.559	107.6		72.40	764.5
3	10	11.541	110.2		74.10	855.2
4		12.566	112.6	1463.9	75.73	951.6
4	3	14.186	116.1		78.12	1108.2
4	6	15.904	119.6	2007	80.43	1279.2
4	9	17.721	122.8		82.20	1456.8
5		19.635	126.1	2659	84.83	1665.7
5	3	21.648	129.3		86.99	1883.2
5	6	23.758	132.4	3429	89.07	2116.2
5	9	25.967	135.4		91.08	2365
5		28.274	138.4	4322	93.08	2631.7
6	6	33.183	144.1	5339	96.93	3216.4
7		38.485	149.6	6510	100.61	3872.5
7	6	44.179	154.9	7814	104.11	4601.9
8		50.266	160	9272	107.61	5409.9
8	6	56.745	165	10889	111	6299.1
9		63.617	169.8	12663	114.2	7267.3
9	6	70.882	174.5	14597	117.4	8329.6
10		78.540	179.1	16709	120.4	9460.9
10	6	86.590	183.6	18996	123.4	10690
11		95.033	187.9	21464	126.3	12010
11	6	103.869	192.2	24139	129.3	13429
12		113.098	196.3	26981	132	14935
12	6	122.719	200.4	30041	134.8	16545
13		132.733	204.4	33301	137.5	18252
13	6	143.139	208.3	36752	140.1	20056
14		153.938	212.2	40432	142.7	21971
14	6	165.130	216.0	44322	145.2	23986
15		176.715	219.6	48413	147.7	26103
15	6	188.692	223.3	52753	150.1	28335
16		201.062	226.9	57343	152.6	30686
16	6	213.825	230.4	62132	155	33144
17		226.981	233.9	67140	157.3	35704
17	6	240.529	237.3	72409	159.6	38389
18		254.170	240.7	77932	161.9	41199
19		283.529	247.3	89759	166.4	47186
20		314.159	253.8	102559	170.7	53633

Flow of Water in Circular Pipes from 3/8 Inch to 12 Inches Diameter.

Based on Darcy's formula for clean cast-iron pipes.  $Q = ac \sqrt{r} \sqrt{s}$ .

Value of $ac\sqrt{r}$ .	Dia. in.	Slope, or Head Divided by Length of Pipe.							
		1 in 10	1 in 20	1 in 40	1 in 60	1 in 80	1 in 100	1 in 150	1 in 200
		Quantity in cubic feet per second.							
.00403	3/8	.00127	.00090	.00064	.00052	.00045	.00040	.00033	.00028
.00914	1/2	.00289	.00204	.00145	.00118	.00102	.00091	.00075	.00065
.02855	3/4	.00903	.00638	.00451	.00369	.00319	.00286	.00233	.00202
.06334	1	.02003	.01416	.01001	.00818	.00708	.00633	.00517	.00448
.11659	1 1/4	.03687	.02607	.01843	.01505	.01303	.01166	.00952	.00824
.19115	1 1/2	.06044	.04274	.03022	.02468	.02137	.01912	.01561	.01352
.28936	1 3/4	.09140	.06470	.04575	.03736	.03235	.02894	.02363	.02046
.41357	2	.13077	.09247	.06539	.05339	.04624	.04136	.03377	.02927
.74786	2 1/2	.23647	.16722	.11824	.09655	.08361	.07479	.06106	.05288
1.2089	3	.38225	.27031	.19113	.15607	.13515	.12089	.09871	.08548
2.5630	4	.81042	.57309	.40521	.33088	.28654	.25630	.20927	.18123
4.5610	5	1.4422	1.0198	.72109	.58882	.50992	.45610	.37241	.32251
7.3068	6	2.3104	1.0338	1.1552	.94331	.81690	.73068	.59660	.51666
10.852	7	3.4314	2.4265	1.7157	1.4110	1.2132	1.0852	.88607	.76734
15.270	8	4.8284	3.4143	2.4141	1.9713	1.7072	1.5270	1.2468	1.0797
20.652	9	6.5302	4.6178	3.2651	2.6662	2.3089	2.0652	1.6862	1.4603
26.952	10	8.5222	6.0265	4.2611	3.4795	3.0132	2.6952	2.2006	1.9058
34.428	11	10.886	7.6981	5.4431	4.4447	3.8491	3.4428	2.8110	2.4344
42.918	12	13.571	9.5965	6.7853	5.5407	4.7982	4.2918	3.5043	3.0347
Value of $\sqrt{s} =$		0.3162	0.2236	0.1581	0.1291	0.1118	0.1	0.08165	0.07071

Value of $ac\sqrt{r}$ .	Dia. in.	Slope, or Head Divided by Length of Pipe.							
		1 in 250	1 in 300	1 in 350	1 in 400	1 in 450	1 in 500	1 in 550	1 in 600
.00403	3/8	.00025	.00023	.00022	.00020	.00019	.00018	.00017	.00016
.00914	1/2	.00058	.00053	.00049	.00046	.00043	.00041	.00039	.00037
.02855	3/4	.00181	.00165	.00153	.00143	.00134	.00128	.00122	.00117
.06334	1	.00400	.00366	.00339	.00317	.00298	.00283	.00270	.00259
.11659	1 1/4	.00737	.00673	.00623	.00583	.00549	.00521	.00497	.00476
.19115	1 1/2	.01209	.01104	.01022	.00956	.00901	.00855	.00815	.00780
.28936	1 3/4	.01830	.01671	.01547	.01447	.01363	.01294	.01234	.01181
.41357	2	.02615	.02388	.02211	.02068	.01948	.01849	.01763	.01688
.74786	2 1/2	.04730	.04318	.03997	.03739	.03523	.03344	.03189	.03053
1.2089	3	.07645	.06980	.06462	.06045	.05695	.05406	.05155	.04935
2.5630	4	.16208	.14799	.13699	.12815	.12074	.11461	.10929	.10463
4.5610	5	.28843	.26335	.24379	.22805	.21487	.20397	.19448	.18620
7.3068	6	.46208	.42189	.39055	.36534	.34422	.32676	.31156	.29830
10.852	7	.68628	.62660	.58005	.54260	.51124	.48530	.46273	.44303
15.270	8	.96567	.88558	.81617	.76350	.71936	.68286	.65111	.62340
20.652	9	1.3060	1.1924	1.1038	1.0326	.97292	.92356	.88060	.84310
26.952	10	1.7044	1.5562	1.4405	1.3476	1.2697	1.2053	1.1492	1.1003
34.428	11	2.1772	1.9878	1.8402	1.7214	1.6219	1.5396	1.4680	1.4055
42.918	12	2.7141	2.4781	2.2940	2.1459	2.0219	1.9193	1.8300	1.7521
Value of $\sqrt{s} =$		.06324	.05774	.05345	.05	.04711	.04472	.04264	.04082

For U. S. gals. per sec., multiply the figures in the table by . . . . . 7.4805  
 " " " " min., " " " " . . . . . 448.83  
 " " " " hour, " " " " . . . . . 26929.8  
 " " " " 24 hrs., " " " " . . . . . 646315.

For any other slope the flow is proportional to the square root of the slope; thus, flow in slope of 1 in 100 is double that in slope of 1 in 400.

**Flow of Water in Standard Sizes of Lap-Welded Pipe.**  
 Calculated from the Hazen and Williams formula with  $C = 100$

		Drop in pressure, lb. per sq. in. per 1000 feet length.									
		0.001	0.002	0.004	0.008	0.016	0.032	0.050	0.100	0.200	0.400
		1000 ft.	500 ft.	250 ft.	125 ft.	62.5 ft.	31.25 ft.	20 ft.	10 ft.	5 ft.	2.5 ft.
		5.28	10.56	21.12	42.24	82.48	16.3	26.4	52.8	105.6	211.2
Pipe Sizes, Inches.	Internal Diam., Inches.	Flow in cubic feet per second.									
$\frac{1}{2}$	0.622	0.0004317	0.0006277	0.0009127	0.001327	0.001929	0.002805	0.003570	0.005191	0.007547	0.01097
$\frac{3}{4}$	0.824	0.0009046	0.001315	0.001912	0.002780	0.004043	0.005878	0.007480	0.01088	0.01581	0.02299
1	1.049	0.001707	0.002482	0.003608	0.005246	0.007628	0.01109	0.01411	0.02052	0.02984	0.04338
$1\frac{1}{4}$	1.380	0.003511	0.005105	0.007472	0.01079	0.01569	0.02281	0.02903	0.04221	0.06137	0.08924
$1\frac{1}{2}$	1.610	0.005266	0.007657	0.01113	0.01619	0.02354	0.03422	0.04355	0.06331	0.09206	0.1338
2	2.067	0.01016	0.01477	0.02148	0.03123	0.04541	0.06602	0.08401	0.1221	0.1776	0.2582
$2\frac{1}{2}$	2.469	0.01621	0.02357	0.03428	0.04984	0.07246	0.1054	0.1341	0.1949	0.2834	0.4121
3	3.068	0.02871	0.04174	0.06069	0.08824	0.1283	0.1865	0.2374	0.3451	0.5018	0.7296
$3\frac{1}{2}$	3.548	0.04207	0.06117	0.08894	0.1293	0.1880	0.2734	0.3479	0.5058	0.7155	1.069
4	4.056	0.05866	0.08529	0.1240	0.1803	0.2622	0.3812	0.4851	0.7053	1.025	1.491
$4\frac{1}{2}$	4.506	0.08073	0.1174	0.1707	0.2481	0.3608	0.5246	0.6675	0.9705	1.411	2.052
5	5.047	0.1015	0.1476	0.2146	0.3120	0.4537	0.6596	0.8394	1.220	1.775	2.580
6	6.065	0.1723	0.2506	0.3643	0.5297	0.7702	1.120	1.425	2.072	3.013	4.380
7	7.023	0.2535	0.3685	0.5358	0.7791	1.133	1.647	2.096	3.047	4.431	6.442
8	7.981	0.3548	0.5158	0.7500	1.090	1.586	2.305	2.934	4.265	6.202	9.017
9	8.941	0.4783	0.6954	1.011	1.470	2.138	3.108	3.955	5.750	8.361	12.16
10	10.02	0.6454	0.9384	1.364	1.984	2.884	4.194	5.337	7.759	11.28	16.40
11	11.00	0.8249	1.199	1.744	2.536	3.687	5.360	6.821	9.918	14.42	20.97
12	12.00	1.037	1.508	2.192	3.188	4.635	6.739	8.575	12.47	18.13	26.36
13	13.25	1.346	1.957	2.845	4.137	6.015	8.745	11.13	16.18	23.53	34.20
14	14.25	1.630	2.369	3.445	5.009	7.283	10.59	13.47	19.59	28.49	41.42
15	15.25	1.948	2.832	4.118	5.987	8.705	12.66	16.11	23.42	34.05	49.51
17 O.D.	16.214	2.289	3.327	4.838	7.034	10.23	14.87	18.92	27.51	40.00	58.17
18 O.D.	17.182	2.666	3.876	5.635	8.193	11.91	17.32	22.04	32.05	46.60	67.75
20 O.D.	19.182	3.563	5.180	7.532	10.95	15.92	23.15	29.46	42.84	62.28	90.56



**Flow of Water in Cubic Feet per Second.  
Pipes 1 Ft. to 20 Ft. Diameter.**

Calculated from the Hazen and Williams formula with  $C = 100$ .

Actual Internal Diam., In.	Fall, Feet per 1000									
	1	2	3	4	6	8	10	15	20	40
	Drop in Pressure, Lb. per Sq. In. per 1000 Ft. Length.									
	0.433	0.866	1.299	1.732	2.598	5.464	4.330	6.495	8.660	17.32
12	1.037	1.508	1.877	2.192	2.729	3.188	3.596	4.475	5.228	8.335
13	1.280	1.861	2.317	2.706	3.368	3.934	4.438	5.524	6.453	10.29
14	1.555	2.262	2.815	3.288	4.093	4.781	5.393	6.713	7.842	12.50
15	1.865	2.712	3.375	3.943	4.908	5.732	6.466	8.048	9.402	14.99
16	2.210	3.213	4.000	4.672	5.815	6.793	7.663	9.537	11.14	17.76
18	3.012	4.380	5.452	6.368	7.927	9.259	10.45	13.00	15.19	24.21
20	3.974	5.778	7.193	8.402	10.46	12.22	13.78	17.15	20.04	31.94
22	5.100	7.415	9.231	10.78	13.42	15.68	17.68	22.01	25.71	40.99
Diam., Ft.	6.420	9.334	11.62	13.57	16.89	19.73	22.26	27.70	32.36	51.60
2	6.420	9.334	11.62	13.57	16.89	19.73	22.26	27.70	32.36	51.60
2 1/2	11.54	16.79	20.89	24.41	30.38	35.48	40.03	49.80	58.20	92.79
3	18.65	27.11	33.75	39.42	49.07	57.32	64.66	80.48	94.01	149.9
3 1/2	27.97	40.67	50.62	59.13	73.60	85.97	96.98	120.7	141.0	224.8
4	39.74	57.78	71.92	84.01	104.6	122.1	137.8	171.5	200.3	319.4
4 1/2	54.17	78.76	98.04	114.5	142.5	166.5	187.8	233.8	273.1	435.4
5	71.46	103.9	129.3	151.1	188.1	219.7	247.8	308.4	360.3	574.4
5 1/2	91.82	133.5	166.2	194.1	241.7	282.2	318.4	396.3	462.9	738.0
6	115.4	167.8	208.9	244.0	303.8	354.8	400.2	498.2	581.9	927.8
6 1/2	142.5	207.2	257.9	301.2	374.9	437.9	494.0	614.9	718.3	1145
7	173.1	251.7	313.4	366.0	455.6	532.2	600.3	747.2	872.9	1392
7 1/2	207.6	301.8	375.7	438.8	546.3	638.1	719.8	859.9	1047	1668
8	246.0	357.7	445.2	520.0	647.3	756.1	852.9	1062	1240	1977
8 1/2	288.5	419.5	522.2	609.9	759.2	886.8	1000	1245	1455	2319
9	335.3	487.5	606.9	708.9	882.4	1031	1163	1447	1690	2695
10	442.4	643.2	800.6	935.2	1164	1360	1534	1909	2230	3556
11	568.4	826.4	1029	1202	1496	1747	1971	2453	2866	4568
12	714.6	1015	1293	1511	1880	2196	2478	3084	3602	5743
13	882.0	1282	1596	1865	2321	2711	3058	3807	4447	7089
14	1072	1558	1940	2266	2820	3294	3716	4625	5403	8614
15	1285	1868	2326	2717	3381	3950	4456	5546	6478	10328
16	1223	2214	2756	3219	4007	4681	5280	6572	7677	12239
17	1786	2597	3232	3776	4700	5490	6193	7708	9004	14354
18	2076	3018	3757	4388	5462	6380	7197	8958	10464	16683
19	2393	3479	4331	5059	6297	7355	8297	10327	12063	19232
20	2738	3982	4956	5789	7206	8417	9495	11818	13806	22010

**Long Pipe Lines.**—(1) Vyrnwy to Liverpool, 68 miles; 40 million gals. (British) per day. Three lines of cast-iron pipe, 42 to 39 in. diam. One of the 42-in. lines after being laid 12 years, with a hydraulic gradient of 4.5 ft. per mile, discharged 15 million gallons per day; velocity, 2.892 ft. per sec.,  $f = 0.00574$ .

(2) East Jersey riveted steel pipe line, Newark, N. J., 21 miles long, 48 in. diam., 50 million U. S. gals. per day; velocity about 6 ft. per sec.

(3) Perth to Coolgarlie, Western Australia, 351 miles, 30 in. steel pipe with lock-bar joints. Eight pumping stations in the line. Two tests showed delivery of 5 and 5.6 million gals. per day; hydraulic gradient, 2.25 and 2.8 ft. per mile; velocity, 1.889 and 2.115 ft. per sec.;  $f = 0.00480$  and 0.00486.

**Flow of Water in Riveted Steel Pipes.**—The laps and rivets tend to decrease the carrying capacity of the pipe. See paper on "New Formulas for Calculating the Flow of Water in Pipes and Channels," by W. E. Foss, *Jour. Assoc. Eng. Soc.*, xiii, 295. Also Clemens Herschel's book on "115 Experiments on the Carrying Capacity of Large Riveted Metal Conduits," John Wiley & Sons, 1897.

## Flow of Water in House-service Pipes.

Mr. E. Kuichling, C. E., furnished the following table to the Thomson Meter Co.:

Condition of Discharge.	Pressure in Main, pounds per square inch.	Discharge, or Quantity capable of being delivered, in Cubic Feet per Minute, from the Pipe, under the conditions specified in the first column.								
		Nominal Diameters of Iron or Lead Service-pipe in Inches.								
		1/2	5/8	3/4	1	1 1/2	2	3	4	6
Through 35 feet of service-pipe, no back pressure.	30	1.10	1.92	3.01	6.13	16.58	33.34	88.16	173.85	444.63
	40	1.27	2.22	3.48	7.08	19.14	38.50	101.80	200.75	513.42
	50	1.42	2.48	3.89	7.92	21.40	43.04	113.82	224.44	574.02
	60	1.56	2.71	4.26	8.67	23.44	47.15	124.68	245.87	628.81
	75	1.74	3.03	4.77	9.70	26.21	52.71	139.39	274.89	703.03
	100	2.01	3.50	5.50	11.20	30.27	60.87	160.96	317.41	811.79
	130	2.29	3.99	6.28	12.77	34.51	69.40	183.52	361.91	925.58
Through 100 feet of service-pipe, no back pressure.	30	0.66	1.16	1.84	3.78	10.40	21.30	58.19	118.13	317.23
	40	0.77	1.34	2.12	4.36	12.01	24.59	67.19	136.41	366.30
	50	0.86	1.50	2.37	4.88	13.43	27.50	75.13	152.51	409.54
	60	0.94	1.65	2.60	5.34	14.71	30.12	82.30	167.06	448.63
	75	1.05	1.84	2.91	5.97	16.45	33.68	92.01	186.78	501.58
	100	1.22	2.13	3.36	6.90	18.99	38.89	106.24	215.68	579.18
	130	1.39	2.42	3.83	7.86	21.66	44.34	121.14	245.91	660.36
Through 100 feet of service-pipe, and 15 feet vertical rise.	30	0.55	0.96	1.52	3.11	8.57	17.55	47.90	97.17	260.56
	40	0.66	1.15	1.81	3.72	10.24	20.95	57.20	116.01	311.09
	50	0.75	1.31	2.06	4.24	11.67	23.87	65.18	132.20	354.49
	60	0.83	1.45	2.29	4.70	12.94	26.48	72.28	146.61	393.13
	75	0.94	1.64	2.59	5.32	14.64	29.96	81.79	165.90	444.85
	100	1.10	1.92	3.02	6.21	17.10	35.00	95.55	193.82	519.72
	130	1.26	2.20	3.48	7.14	19.66	40.23	109.82	222.75	597.31
Through 100 feet of service-pipe, and 30 feet vertical rise.	30	0.44	0.77	1.22	2.50	6.80	14.11	38.63	78.54	211.54
	40	0.55	0.97	1.53	3.15	8.68	17.79	48.68	98.98	266.59
	50	0.65	1.14	1.79	3.69	10.16	20.82	56.98	115.87	312.08
	60	0.73	1.28	2.02	4.15	11.45	23.47	64.22	130.59	351.73
	75	0.84	1.47	2.32	4.77	13.15	26.95	73.76	149.99	403.98
	100	1.00	1.74	2.75	5.65	15.58	31.93	87.38	177.67	478.55
	130	1.15	2.02	3.19	6.55	18.07	37.02	101.33	206.04	554.96

In this table it is assumed that the pipe is straight and smooth inside; that the friction of the main and meter are disregarded; that the inlet from the main is of ordinary character, sharp, not flaring or rounded, and that the outlet is the full diameter of pipe. The deliveries given will be increased if, first, the pipe between the meter and the main is of larger diameter than the outlet; second, if the main is tapped, say for 1-inch pipe, but is enlarged from the tap to 1 1/4 or 1 1/2 inch; or, third, if pipe on the outlet is larger than that on the inlet side of the meter. The exact details of the conditions given are rarely met in practice; consequently the quantities of the table may be expected to be decreased, because the pipe is liable to be throttled at the joints, additional bends may interpose, or stop-cocks may be used, or the back-pressure may be increased.

**Friction Loss in Clean Cast-Iron Pipe.**

Compiled from Weston's "Friction of Water in Pipes" as computed from formulas of Henry Darcy.

Pounds loss per 1000 feet in pipe of given diameter. (Small lower figures give Velocity in Feet per Second.)

U. S. Gals per Min. and (Cu. Ft. per Sec.)	Diameter of Pipe in Inches.											
	3	4	5	6	8	10	12	14	16	20	24	30
<b>250</b>	60	20	6.4	2.5	0.6	0.2	0.07	0.03	0.02	0.01	0.00	.....
(0.56)	11	6.4	4.0	2.8	1.6	1.2	0.7	0.52	0.4	0.26	0.18	.....
<b>500</b>	220	82	25.8	10.0	2.3	0.7	0.29	0.13	0.07	0.02	0.01	0.00
(1.11)	23	13.0	8.2	6.0	3.2	2.4	1.4	1.04	0.8	0.51	0.35	0.23
<b>750</b>	477	184	58.0	23.0	5.0	1.6	0.66	0.30	0.15	0.05	0.02	.....
(1.67)	34	19.0	12.2	8.0	4.8	3.1	2.1	1.56	1.2	0.77	0.53	.....
<b>1,000</b>	.....	328	103.0	40.0	9.0	2.9	1.20	0.53	0.27	0.09	0.03	0.01
(2.23)	.....	26.0	16.3	11.0	6.4	4.1	2.8	2.08	1.6	1.0	0.71	0.45
<b>1,250</b>	.....	.....	161.0	63.0	14.0	4.6	1.80	0.83	0.42	0.14	0.06	.....
(2.79)	.....	.....	20.4	14.0	8.0	5.1	3.6	2.60	2.0	1.3	0.89	.....
<b>1,500</b>	.....	.....	231.9	91.0	21.0	6.6	2.60	1.10	0.61	0.20	0.08	0.03
(3.34)	.....	.....	24.5	17.0	10.0	6.1	4.3	3.13	2.4	1.5	1.06	0.68
<b>1,750</b>	.....	.....	.....	123.0	28.0	9.0	3.60	1.64	0.83	0.27	0.11	.....
(3.90)	.....	.....	.....	20.0	11.0	7.1	5.0	3.65	2.8	1.8	1.24	.....
<b>2,000</b>	.....	.....	.....	160.0	37.0	12.0	4.70	2.14	1.10	0.35	0.14	0.05
(4.46)	.....	.....	.....	23.0	13.0	8.2	5.7	4.17	3.2	2.0	1.42	0.91
<b>2,500</b>	Diam. of Pipe in In.		.....	.....	58.0	18.0	7.30	3.34	1.70	0.55	0.22	0.07
(5.57)	.....		.....	.....	16.0	10.2	7.1	5.21	4.0	2.6	1.80	1.13
<b>3,000</b>	.....		.....	.....	.....	26.0	10.00	4.81	2.40	0.79	0.32	0.10
(6.68)	<b>36</b>	<b>48</b>	.....	.....	.....	12.0	8.5	6.25	4.8	3.1	2.10	1.40
<b>4,000</b>	.....	.....	.....	.....	.....	.....	.....	8.55	4.30	1.40	0.56	0.18
(8.91)	.....	.....	.....	.....	.....	.....	.....	8.34	6.4	4.1	2.80	1.80
<b>5,000</b>	0.11	0.03	.....	.....	.....	.....	.....	.....	6.80	2.20	1.00	0.29
(11.14)	1.6	0.89	.....	.....	.....	.....	.....	.....	8.0	5.1	3.60	2.30
<b>6,000</b>	0.16	0.04	.....	.....	.....	.....	.....	.....	.....	3.20	1.30	0.41
(13.37)	1.9	1.06	.....	.....	.....	.....	.....	.....	.....	6.1	4.30	2.70
<b>7,000</b>	0.23	0.05	.....	.....	.....	.....	.....	.....	.....	4.30	1.70	0.56
(15.60)	2.2	1.2	.....	.....	.....	.....	.....	.....	.....	7.1	5.00	3.20
<b>8,000</b>	0.29	0.07	.....	.....	.....	.....	.....	.....	.....	.....	2.20	0.73
(17.82)	2.5	1.4	.....	.....	.....	.....	.....	.....	.....	.....	5.70	3.60
<b>9,000</b>	0.37	0.09	.....	.....	.....	.....	.....	.....	.....	.....	2.80	0.92
(20.05)	2.8	1.6	.....	.....	.....	.....	.....	.....	.....	.....	6.40	4.10
<b>10,000</b>	0.45	0.11	.....	.....	.....	.....	.....	.....	.....	.....	.....	1.13
(22.28)	3.1	1.8	.....	.....	.....	.....	.....	.....	.....	.....	.....	4.50

Vel. ft. per sec..	1	2	3	4	5	6	7	8	9	10	11	12
Hd. due vel. ft.	0.016	0.062	0.14	0.25	0.39	0.56	0.76	1.0	1.3	1.6	1.9	2.2
Vel. ft. per sec..	13	14	15	16	17	18	19	20	25	30	40	50
Hd. due vel. ft..	2.6	3.1	3.5	4.0	4.5	5.0	5.6	6.2	9.3	14.0	24.8	38.8

These losses are for *new, clean, straight, tar-coated, cast-iron pipes*. For pipes that have been in service a number of years the losses will be larger on account of corrosion and incrustation, and the losses in the tables should be multiplied under average conditions by the factors opposite; but they must be used with much discretion, for some waters corrode pipes much more rapidly than others.

10 years	1.3
20 "	1.6
30 "	2.0
50 "	2.6
75 "	3.4

The same figures may be used for wrought-iron pipes which are not subject to a frequent change of water.



**Approximate Hydraulic Formulæ.** (The Lombard Governor Co., Boston, Mass.)

Head ( $H$ ) in feet. Pressure ( $P$ ) in lbs. per sq. in. Diameter ( $D$ ) in feet. Area ( $A$ ) in sq. ft. Quantity ( $Q$ ) in cubic ft. per second. Time ( $T$ ) in seconds.

$$\text{Spouting velocity} = 8.02 \sqrt{H}.$$

Time ( $T_1$ ) to acquire spouting velocity in a vertical pipe, or ( $T_2$ ) in a pipe on an angle ( $\theta$ ) from horizontal:

$$T_1 = 8.02 \sqrt{H} + 32.17, \quad T_2 = 8.02 \sqrt{H} + 32.17 \sin \theta.$$

Head ( $H$ ) or pressure ( $P$ ) which will vent any quantity ( $Q$ ) through a round orifice of any diameter ( $D$ ) or area ( $A$ ):

$$H = Q^2 \div 14.1 D^4 = Q^2 \div 23.75 A^2; \quad P = Q^2 \div 34.1 D^4 = Q^2 \div 55.3 A^2.$$

Quantity ( $Q$ ) discharged through a round orifice of any diameter ( $D$ ) or area ( $A$ ) under any pressure ( $P$ ) or under any head ( $H$ ):

$$\begin{aligned} Q &= \sqrt{P \times 55.3 \times A^2} = \sqrt{P \times 34.1 \times D^4}; \\ &= \sqrt{H \times 23.75 \times A^2} = \sqrt{H \times 14.71 \times D^4}. \end{aligned}$$

Diameter ( $D$ ) or area ( $A$ ) of a round orifice to vent any quantity ( $Q$ ) under any head ( $H$ ) or under any pressure ( $P$ ):

$$D = \sqrt{Q \div 3.84 \sqrt{H}} = \sqrt{Q \div 5.8 \sqrt{P}}; \quad A = Q \div 4.89 \sqrt{H} = Q \div 7.35 \sqrt{P}.$$

Time ( $T$ ) of emptying a vessel of any area ( $A$ ) through an orifice of any area ( $a$ ) anywhere in its side:  $T = 0.416 A \sqrt{H} \div a$ .

Time ( $T$ ) of lowering a water level from ( $H$ ) to ( $h$ ) in a tank of area  $A$  through an orifice of any area ( $a$ ) in its side.  $T = 0.416 A (\sqrt{H} - \sqrt{h}) \div a$ .

Kinetic energy ( $K$ ) or foot-pounds in water in a round pipe of any diameter ( $D$ ) when moving at velocity ( $V$ ):  $K = 0.76 \times D^2 \times L \times V^2$ .

Area ( $a$ ) of an orifice to empty a tank of any area ( $A$ ) in any time ( $T$ ) from any head ( $H$ ):  $a = T \div 0.409 A \sqrt{H}$ .

Area ( $a$ ) of an orifice to lower water in a tank of area ( $A$ ) from head ( $H$ ) to ( $h$ ) in time ( $T$ ):  $a = T \div 0.409 \times A \times (\sqrt{H} - \sqrt{h})$ .

**Compound Pipes and Pipes with Branches.** (Unwin.) — Loss of head in a main consisting of different diameters. (1) Constant discharge. Total loss of head  $H = h_1 + h_2 + h_3 = 0.1008 f Q^2 (l_1/d_1^5 + l_2/d_2^5 + l_3/d_3^5)$ .

(2) Constant velocity in the main, the discharge diminishing from section to section.  $H = 0.0551 f v^{5/2} (l_1/\sqrt{Q_1} + l_2/\sqrt{Q_2} + l_3/\sqrt{Q_3})$ . Equivalent main of uniform diameter. Length of equivalent main

$$l = d^5 (l_1/d_1^5 + l_2/d_2^5 + l_3/d_3^5).$$

Loss of head in a main of uniform diameter in which the discharge decreases uniformly along its length, such as a main with numerous branch pipes uniformly spaced and delivering equal quantities:  $h = 0.0336 f Q^2 l/d^5$ ,  $Q$  being the quantity entering the pipe. The loss of head is just one-third of the loss in a pipe carrying the uniform quantity  $Q$  throughout its length.

Loss of head in a pipe that receives  $Q$  cu. ft. per sec. at the inlet, and delivers  $Q_x$  cu. ft. at  $x$  ft. from the inlet, having distributed  $qx$  cu. ft. uniformly in that distance,  $h_x = 0.1008 fx (Q_x + 0.55 qx) / d^5$ .

Delivery by two or more mains, in parallel. Total discharge  $= Q_1 + Q_2 + Q_3 = 3.149 \sqrt{h/f} (\sqrt{d_1^5/l_1} + \sqrt{d_2^5/l_2} + \sqrt{d_3^5/l_3})$ . Diameter of an equivalent main to discharge the same total quantity,  $d = (\sqrt{d_1^5} + \sqrt{d_2^5} + \sqrt{d_3^5})^{2/5}$ .

**Rifled Pipes for Conveying Heavy Oils.** (*Eng. Rec.*, May 23, 1908.) — The oil from the California fields is a heavy, viscous fluid. Attempts to handle it in long pipe lines of the ordinary type have not been practically successful. High pumping pressures are required, resulting in large expense for pipe and for pumping equipment.

The method of pumping in the rifled-pipe line is to inject about 10 per cent of water with the oil and to give the oil and water a centrifugal motion, by means of the rifled pipe, sufficient to throw the water to the outside, where it forms a thin film of lubrication between the oil and the sides of the pipe that greatly reduces the friction. The rifled pipe delivers at ordinary temperatures eight to ten times as much oil, through a long line, as does a line of ordinary pipe under similar conditions. An 8-in. rifled pipe line 282 miles in length has been built from the Kern oil fields to Porta Costa, on tidewater near San Francisco. The pipe is rifled with six helical grooves to the circumference, these grooves making a complete turn through 360 deg. in 10 ft. of length.

**Loss of Pressure Caused by Valves and Fittings** —The data given below are condensed from the results of experiments by John R. Freeman for the Inspection Department of the Assoc. Facty. Mut. Ins. Cos. The friction losses in ells and tees are approximate. Fittings of the same nominal size with the different curvatures and different smoothness as made by different manufacturers will cause materially different friction losses. The figures are the number of feet of clean, straight pipe of same size which would cause the same loss as the fitting. Grinnell dry-pipe valve, 6-in., 80 ft.; 4-in., 47 ft. Grinnell alarm check, 6-in., 100 ft.; 4-in., 47 ft. Pratt & Cady check valve, 6-in., 50 ft.; 4-in., 25 ft. 4-in. Walworth globe check valve, 6-in., 200 ft.; 4-in., 130 ft. 2 1/2 in. to 8-in. ells, long-turn, 4 ft.; short-turn 9 ft. 3-in. to 8-in. tees, long-turn, 9 ft.; short-turn, 17 ft. One-eighth bend, 5 ft.

**Effect of Bends and Curves in Pipes.** — Weisbach's rule for bends:

$$\text{Loss of head in feet} = \left[ 0.131 + 1.847 \left( \frac{r}{R} \right)^{7/2} \right] \times \frac{v^2}{64.4} \times \frac{a}{180}$$

in which  $r$  = internal radius of pipe in feet,  $R$  = radius of curvature of axis of pipe,  $v$  = velocity in feet per second, and  $a$  = the central angle, or angle subtended by the bend.

Hamilton Smith, Jr., in his work on Hydraulics, says: The experimental data at hand are entirely insufficient to permit a satisfactory analysis of this quite complicated subject; in fact, about the only experiments of value are those made by Bossut and Dubuat with small pipes.

**Curves.** — If the pipe has easy curves, say with radius not less than 5 diameters of the pipe, the flow will not be materially diminished, provided the tops of all curves are kept below the hydraulic grade-line and provision be made for escape of air from the tops of all curves. (Trautwine.)

Williams, Hubbell and Fenkel (*Trans. A. S. C. E.*, 1901) conclude from an extensive series of experiments that curves of short radius, down to about 2 1/2 diameters, offer less resistance to the flow of water than do those of longer radius, and that earlier theories and practices regarding curve resistance are incorrect. For a 90° curve in 30 in. cast-iron pipe, 6 ft. radius, they found the loss of head 15.7% greater than that of a straight pipe of equal length; with 10 ft. radius, 17.3% greater; with 25 ft. radius, 52.7% greater; and with 60 ft. radius, 90.2% greater.

**Friction Heads for Elbows. Heads Required to Overcome the Resistance of Circular 90° Bends.**  
(U. S. Cast Iron Pipe & Foundry Co.)

Velocity in Feet Per Second.	Radius of Bend in Diameters of Pipe.							
	0.5	0.75	1.00	1.25	1.5	2.0	3.0	5.0
	Head, in Feet.							
1	0.016	0.005	0.002	0.002	0.001	0.001	0.001	0.001
2	.062	.018	.009	.007	.005	.005	.004	.004
3	.140	.041	.020	.015	.012	.011	.010	.009
4	.245	.072	.036	.026	.021	.019	.017	.016
5	.388	.113	.056	.041	.033	.029	.027	.025
6	.559	.162	.081	.059	.048	.042	.038	.036
7	.761	.221	.110	.080	.066	.057	.052	.050
8	.994	.288	.144	.104	.086	.074	.069	.065
9	1.260	.365	.182	.132	.108	.094	.086	.082
10	1.550	.450	.225	.163	.134	.116	.106	.101
12	2.340	.649	.324	.236	.192	.167	.153	.145

**Loss of Head in Pipes, Tees and Elbows.**—Results of tests made on locomotive water columns by Arthur N. Talbot and Melvin L. Enger (Bulletin No. 48, Univ. of Ill. Engineering Experiment Station) may be expressed by the following formula: Loss of head in 100 ft. of new cast-iron pipe for sizes above 6 in. diam. =  $0.044 v^{1.8} \div d^{1.25}$ , in which  $v$  = velocity of flow in feet per sec., and  $d$  = internal diameter of pipe, in ft. The results for pipes from 8 to 24 in. in diameter agree closely with those obtained by Williams and Hazen for pipes after about three years of service, with the diagram given in Turneure and Russell's "Public Water Supplies," and with the formula of Unwin; they are, however, generally smaller than those given by the Ellis and Howland tables and by Darcy's formula.

The following tables are taken from diagrams included in the Bulletin; they give the values selected by the Committee on Water Service, Am. Ry. Eng'g and Maintenance of Way Association, as representing the maximum results of numerous tests.

LOSS OF HEAD IN TEES, IN FEET.

Discharge, Gal. per Min.	Cu. Ft. per Sec.	Sizes of Tees.					
		8 In.	10 In.	12 In.	14 In.	16 In.	18 In.
1000.....	20.5	1.1	0.4	0.25	.....	.....	.....
2000.....	41	4	1.7	0.95	0.40	0.25	0.13
3000.....	61.5	8.7	3.9	1.95	1.00	0.60	0.35
4000.....	82	.....	6.7	3.35	1.75	1.10	0.65
5000.....	102.5	.....	10.3	5.20	2.70	1.60	1.00
6000.....	123	.....	.....	7.30	3.90	2.30	1.45
7000.....	143.5	.....	.....	.....	5.30	3.10	2.00
8000.....	164	.....	.....	.....	6.80	3.90	2.60

LOSS OF HEAD IN ELBOWS, IN FEET.

(Radius of curvature of elbow axis =  $1.5 \times$  diameter of elbow.)

Discharge, Gal. per Min.	Cu. Ft. per Sec.	Sizes of Elbows.					
		8 In.	10 In.	12 In.	14 In.	16 In.	18 In.
1000.....	20.5	0.2	.....	.....	.....	.....	.....
2000.....	41	1.2	0.5	0.20	0.10	.....	.....
3000.....	61.5	2.8	1.1	0.50	0.25	0.15	.....
4000.....	82	.....	1.9	0.95	0.50	0.25	0.10
5000.....	102.5	.....	3.2	1.50	0.75	0.40	0.15
6000.....	123	.....	.....	2.20	1.15	0.60	0.25
7000.....	143.5	.....	.....	3.00	1.65	0.87	0.50
8000.....	164	.....	.....	.....	2.10	1.15	0.70

(Radius of curvature =  $3 \times$  diameter.)

1000.....	20.5	0.25	.....	.....	.....	.....	.....
2000.....	41	0.75	0.35	0.10	.....	.....	.....
3000.....	61.5	2.00	0.80	0.40	0.15	.....	.....
4000.....	82	4.00	1.45	0.70	0.33	0.12	.....
5000.....	102.5	.....	2.25	1.10	0.50	0.20	0.07
6000.....	123	.....	.....	1.60	0.70	0.40	0.10
7000.....	143.5	.....	.....	2.20	1.00	0.58	0.25
8000.....	164	.....	.....	3.00	1.45	0.85	0.45

**Hydraulic Grade-line.**—In a straight tube of uniform diameter throughout, running full and discharging freely into the air, the hydraulic grade-line is a straight line drawn from the discharge end to a point immediately over the entry end of the pipe and at a depth below the surface equal to the entry and velocity heads. (Trautwine.)

In a pipe leading from a reservoir, no part of its length should be above the hydraulic grade-line.

**Air-bound Pipes.**—A pipe is said to be air-bound when, in consequence of air being entrapped at the high points of vertical curves in the line, water will not flow out of the pipe, although the supply is higher than the outlet. The remedy is to provide cocks or valves at the high points,



through which the air may be discharged. The valve may be made automatic by means of a float.

**Water-Hammer.**—When selecting valves and fittings, the possibility of shock or strain due to water-hammer, in excess of the average working pressure of the line or system, should be considered. Many valves and fittings, installed where the working pressure under normal conditions would be low, have failed because of pressure due to water-hammer. This danger can be avoided by proper cushioning of the line by air chambers, or by relief valves.

When a valve in a pipe is closed while the water is flowing, the velocity of the water behind the valve is retarded and a dynamic pressure is produced. When the valve is closed quickly this dynamic pressure may be very great. It is then called "water-hammer" or "water-ram," and it causes in many cases fracture of the pipe. It is provided against by arrangements which prevent the rapid closing of the valve. Formulæ for the pressure produced by this shock are (see Merriman's Hydraulics)

$$p = 0.027 \frac{Lv}{t} - p_0 + p_1. \dots (1) \quad p = 63v - p_0 + p_1. \dots (2)$$

where  $p_0$  = the static pressure, lb. per sq. in., when there is no flow,  $p_1$  = the static pressure when the flow is in progress,  $p$  = the maximum dynamic pressure due to the water-hammer in excess over the pressure  $p_0$ ,  $v$  = the velocity in feet per second,  $L$  = length of pipe back from the valve in feet, and  $t$  = time of closing the valve in seconds. Formula (1) is to be used when  $t$  is greater than  $0.000428L$  and (2) when  $t$  is equal to or less than this.

From the first of these formulæ the value of  $t$  when  $p = 0$  is found to be  $t = 0.027 Lv \div (p_0 - p_1)$ , which is the time required for the valve closing in order that there may be no water-hammer.

**Vertical Jets.** (Molesworth.) —  $H$  = head of water,  $h$  = height of jet,  $d$  = diameter of jet,  $K$  = coefficient, varying with ratio of diameter of jet to head; then  $h = KH$ .

If $H = d \times$	300	600	1000	1500	1800	2800	3500	4500
$K =$	0.96	0.9	0.85	0.8	0.7	0.6	0.5	0.25

**Water Delivered through Meters.** (Thomson Meter Co.) — The best modern practice limits the velocity in water-pipes to 10 lineal feet per second. Assume this as a basis of delivery, and we find, for the several sizes of pipes usually metered, the following approximate results:

Nominal diameter of pipe in inches:									
	$\frac{3}{8}$	$\frac{5}{8}$	$\frac{3}{4}$	1	$1\frac{1}{2}$	2	3	4	6
Quantity delivered, in cubic feet per minute, due to said velocity:	0.46	1.28	1.85	3.28	7.36	13.1	29.5	52.4	117.9

<b>Prices Charged for Water in Different Cities.</b> (National Meter Co.)	
Average minimum price for 1000 gallons in 163 places.....	9.4 cents.
Average maximum price for 1000 gallons in 163 places.....	28 "
Extremes, $2\frac{1}{2}$ cents to.....	100 "

FIRE-STREAMS.

**Fire-Stream Tables.**—The tables on pages 750 and 751 are condensed from one contained in the pamphlet of "Fire-Stream Tables" of the Associated Factory Mutual Fire Ins. Cos., based on the experiments of John R. Freeman, *Trans. A. S. C. E.*, vol. xxi, 1889.

The pressure in the first column is that indicated by a gauge attached at the base of the play pipe and set level with the end of the nozzle. The vertical and horizontal distances, in 2d and 3d cols., are those of effective fire-streams with moderate wind. The maximum limit of a "fair stream" is about 10% greater for a vertical stream; 12% for a horizontal stream. In still air much greater distances are reached by the extreme drops. The pressures given are for the best quality of rubber-lined hose, smooth inside. The hose friction varies greatly in different kinds of hose, according to smoothness of inside surface, and pressures as much as 50% greater are required for the same delivery in long lengths of inferior rubber-lined or linen hose. The pressures at the hydrant are those while the stream is flowing, and are those required with smooth nozzles. Ring

nozzles require greater pressures. With the same pressures at the base or the play pipe, the discharge of a 3/4-in. smooth nozzle is the same as that of a 7/8-in. ring nozzle; of a 7/8-in. smooth nozzle, the same as that of a 1-in. ring nozzle.

The figures for hydrant pressure in the body of the table are derived by adding to the nozzle or play-pipe pressure the friction loss in the hose, and also the friction loss of a Chapman 4-way independent gate hydrant ranging from 0.86 lb. for 200 gals. per min. flowing to 2.31 lbs. for 600 gals.

The following notes are taken from the pamphlet referred to. The discharge as stated in Ellis's tables and in their numerous copies in trade catalogues is from 15 to 20% in error.

In the best rubber-lined hose, 2 1/2-in. diam., the loss of head due to friction, for a discharge of 240 gallons per minute, is 14.1 lbs. per 100 ft. length; in inferior rubber-lined mill hose, 25.5 lbs., and in unlined linen hose, 33.2 lbs.

Less than a 1 1/8-in. smooth-nozzle stream with 40 lbs. pressure at the base of the play pipe, discharging about 240 gals. per min., cannot be called a first-class stream for a factory fire. 80 lbs. per sq. in. is considered the best hydrant pressure for general use; 100 lbs. should not be exceeded, except for very high buildings, or lengths of hose over 300 ft.

**Hydrant Pressures Required with Different Sizes and Lengths of Hose.** (J. R. Freeman, *Trans. A. S. C. E.*, 1889.)

3/4-inch smooth nozzle.

Press. Lbs.	Fire-steam Distance.		Gal. per Min.	Hydrant Pressure with Different Lengths of Hose to Maintain Pressure at Base of Play Pipe.								
	Vert.	Hor.		50 ft.	100 ft.	200 ft.	300 ft.	400 ft.	500 ft.	600 ft.	800 ft.	1000 ft.
10	17	19	52	10	11	11	12	13	13	14	15	16
20	33	29	73	21	22	23	24	25	26	28	30	32
30	48	37	90	31	32	34	36	38	40	41	45	49
40	60	44	104	42	43	46	48	50	53	55	60	65
50	67	50	116	52	54	57	60	63	66	69	75	81
60	72	54	127	63	65	68	72	76	79	83	90	97
70	76	58	137	73	75	80	84	88	92	97	105	114
80	79	62	147	84	86	91	96	101	106	111	120	130
90	81	65	156	94	97	102	108	113	119	124	135	146
100	83	68	164	105	108	114	120	126	132	138	150	163

7/8-inch smooth nozzle.

10	18	21	71	11	11	13	14	15	16	17	19	22
20	34	33	100	22	23	25	27	30	32	34	39	43
30	49	42	123	33	34	38	41	45	48	51	58	65
40	62	49	142	43	46	50	55	59	64	68	78	87
50	71	55	159	54	57	63	69	74	80	86	97	108
60	77	61	174	65	69	75	82	89	96	103	116	130
70	81	66	188	76	80	88	96	104	112	120	136	152
80	85	70	201	87	91	101	110	119	128	137	155	173
90	88	74	213	98	103	113	123	134	144	154	174	195
100	90	76	224	109	114	126	137	148	160	171	194	216

1-inch smooth nozzle.

10	18	21	93	12	12	14	16	18	20	22	26	30
20	35	37	132	23	25	29	33	37	41	45	52	60
30	51	47	161	34	37	43	49	55	61	67	79	90
40	64	55	186	46	50	58	66	73	81	89	105	120
50	73	61	208	57	62	72	82	92	102	111	131	151
60	79	67	228	69	75	87	98	110	122	134	157	181
70	85	72	246	80	87	101	115	128	142	156	183	211
80	89	76	263	92	100	115	131	147	162	178	209	241
90	92	80	279	103	112	130	147	165	183	200	236	....
100	96	83	295	115	125	144	164	183	203	223	.....	....

**Hydrant Pressures Required with Different Sizes and Lengths of Hose.—Continued.**  
 1 1/8-inch smooth nozzle.

Press. lbs.	Fire- Steam Distance.		Gal. per min.	Hydrant Pressure with Different Lengths of Hose to Maintain Pressure at Base of Play Pipe.									
	Vert.	Hor.		50 ft.	100 ft.	200 ft.	300 ft.	400 ft.	500 ft.	600 ft.	800 ft.	1000 ft.	
10	18	22	119	12	14	17	20	24	27	30	36	43	
20	36	38	168	25	28	34	41	47	54	60	73	85	
30	52	50	206	37	42	52	61	71	80	90	109	128	
40	65	59	238	50	56	69	81	94	107	120	145	171	
50	75	66	266	62	70	86	102	118	134	150	181	213	
60	83	72	291	74	84	103	122	141	160	180	218	256	
70	88	77	314	87	98	120	143	165	187	209	254	....	
80	92	81	336	99	112	138	163	188	214	239	.....	.....	
90	96	85	356	112	126	155	183	212	241	.....	.....	.....	
100	99	89	376	124	140	172	204	236	.....	.....	.....	.....	

1 1/4-inch smooth nozzle.

10	19	22	148	14	15	21	26	31	36	41	51	61
20	37	40	209	27	32	42	52	62	72	82	101	121
30	53	54	256	41	49	63	78	93	108	123	152	182
40	67	63	296	55	65	84	104	124	144	164	203	243
50	77	70	331	68	81	106	130	155	180	204	254	....
60	85	76	363	82	97	127	156	186	216	245	.....	.....
70	91	81	392	96	113	148	182	217	252	.....	.....	.....
80	95	85	419	110	129	169	208	248	.....	.....	.....	.....
90	99	90	444	123	145	190	234	.....	.....	.....	.....	.....
100	101	93	468	137	162	211	251	.....	.....	.....	.....	.....

1 3/8-inch smooth nozzle.

10	20	23	182	16	19	27	34	42	49	56	71	86
20	38	42	257	31	39	53	68	83	98	113	143	173
30	55	56	315	47	58	80	103	125	147	169	214	259
40	69	66	363	62	77	107	137	166	196	226	.....	.....
50	79	73	406	78	96	134	171	208	245	.....	.....	.....
60	87	79	445	93	116	160	205	250	.....	.....	.....	.....
70	92	84	480	109	135	187	239	.....	.....	.....	.....	.....
80	97	88	514	124	154	214	.....	.....	.....	.....	.....	.....
90	100	92	545	140	173	240	.....	.....	.....	.....	.....	.....
100	103	96	574	156	193	.....	.....	.....	.....	.....	.....	.....

**Pump Inspection Table.**

Discharge of nozzles attached to 50 ft. of 2 1/2-in. best quality rubber-lined hose, inside smooth. (J. R. Freeman.)

Hydrant Pressure.	Size of Smooth Nozzle.								Ring Nozzle.		
	1 3/4	1 1/2	1 3/8	1 1/4	1 1/8	1	7/8	3/4	1 3/8	1 1/4	1 1/8
10	193	163	146	127	107	87	68	51	118	101	84
20	274	232	206	179	151	123	96	72	167	143	119
30	335	283	251	219	184	150	118	88	205	175	145
40	387	327	291	253	213	173	136	101	237	202	168
50	432	366	325	283	238	194	152	113	264	226	188
60	473	400	357	309	261	213	167	124	289	247	205
70	510	432	385	334	281	230	180	134	313	267	222
80	546	461	412	357	301	246	192	144	334	285	237
90	579	490	437	379	319	251	204	152	355	303	252
100	610	515	461	400	337	275	215	161	374	319	266



**Pipe Sizes for Ordinary Fire-Streams.**  
(U. S. Cast Iron Pipe & Foundry Co., 1914.)

No. of 1 1/8 In. Hose Nozzles.	40 Lb. Pressure.		50 Lb. Pressure.		60 Lb. Pressure.		70 Lb. Pressure.		80 Lb. Pressure.		90 Lb. Pressure.	
	Pipe Size, In.	Flow.	Pipe Size, In.	Flow.	Pipe Size, In.	Flow.	Pipe Size, In.	Flow.	Pipe Size, In.	Flow.	Pipe Size, In.	Flow.
1	4	20	6	23	6	25	6	27	6	29	6	30
2	6	40	8	45	8	50	8	53	8	57	8	61
3	8	61	8	68	10	74	10	80	10	86	10	91
4	10	81	10	90	10	99	10	107	12	114	12	121
5	10	101	12	113	12	124	12	134	12	143	12	152
6	12	121	12	135	12	149	14	160	14	172	14	182
7	12	141	14	158	14	174	14	187	14	200	16	212
8	12	162	14	181	14	199	16	214	16	229	16	242
9	14	182	14	203	16	223	16	241	16	257	18	273
10	14	202	16	226	16	248	16	267	18	286	18	303
11	16	222	16	248	18	273	18	294	18	314	18	333
12	16	243	18	271	18	298	18	321	20	343	20	364
13	16	263	18	293	18	323	20	348	20	372	20	394
14	18	283	18	316	20	348	20	374	20	400	20	424
15	18	303	20	339	20	372	20	401	20	429	24	455

Flow given in cubic feet per minute. Figures are based on 1 1/8-in. smooth-bore nozzles, playing simultaneously and attached to 200 ft. of best quality rubber-lined hose; pressures measured at hose connections. Velocity of water in pipe, approximately 3 ft. per second.

**Friction Loss in Rubber-Lined Cotton Hose with Smoothest Lining.**

Diam. of Hose.	Gallons per Minute Flowing.									Velocity, Ft. per Sec.	Velocity Head $V^2 \div 2g$ .	
	100	200	300	400	500	600	700	800	1000		Ft.	Lbs.
	Friction Loss, Pounds per 100 ft. Length.											
2	6.836	27.3	61.5	109	171	.....	.....	.....	.....	5	0.39	0.17
2 1/8	5.170	20.7	46.5	82.7	129	189	.....	.....	.....	10	1.6	0.69
2 1/4	3.790	15.2	34.1	60.6	94.7	136	186	.....	.....	15	3.5	1.5
2 3/8	2.895	11.6	26.1	46.3	72.4	104	138	185	.....	20	6.2	2.7
2 1/2	2.240	9.0	20.2	35.8	56.0	80.6	110	143	224	25	9.7	4.2
2 5/8	1.748	7.0	15.7	28.0	43.7	62.9	85.7	112	175	30	14.0	6.1
2 3/4	1.391	5.6	12.5	22.3	34.8	50.1	68.2	89.0	139	35	19.0	8.2
2 7/8	1.097	4.4	9.9	17.6	27.4	39.5	53.8	70.2	110	40	24.8	10.7
3	0.900	3.6	8.1	14.4	22.5	32.4	44.1	57.6	90	45	31.4	13.6
3 1/2	0.416	1.7	3.7	6.7	10.4	15.0	20.4	26.6	41.6	50	38.8	16.7
4	0.214	0.9	1.9	3.4	5.4	7.7	10.5	13.7	21.4			

The above table is computed on the basis of 14 lbs. per 100 ft. length of 2 1/2-in. hose with 250 gals. per min. flowing, as found in Freeman's tests, assuming that the loss varies as the square of the quantity, and for different diameters and the same quantity inversely as the 5th power of the diameter.

**Rated Capacities of Steam Fire-engines**, which is perhaps one third greater than their ordinary rate of work at fires, are substantially as follows:

3d size,	550 gals. per min.,	or	792,000 gals. per 24 hours.
2d "	700 "	"	1,008,000 "
1st "	900 "	"	1,296,000 "
1 ext..	1,100 "	"	1,584,000 "

Flow of Water Through Nozzles in Cubic Feet per Second. (Joshua Hendy Iron Works.)

$H$  = head in feet at the nozzle.  $P$  = pressure due to head lbs. per sq. in.  $V$  = theoretical velocity, ft. per sec.

Diam. Nozzle, In.		1	1 1/2	2	2 1/2	3	3 1/2	4	4 1/2	5	6	7	8	9	10	11	12
$H$ .	$P$ .	$V$ .															
5	2.17	17.93	0.098	0.221	0.392	0.611	1.197	1.565	2.040	2.445	3.519	4.810	6.26	7.92	9.78	12.83	14.08
10	4.33	25.36	0.138	0.312	0.553	0.864	1.694	2.213	2.875	3.459	4.978	6.778	8.85	11.20	13.83	16.74	19.92
20	8.66	35.86	0.195	0.441	0.784	1.222	2.395	3.130	4.066	4.885	7.039	9.585	12.52	15.84	19.56	23.67	28.16
30	12.99	43.92	0.241	0.540	0.957	1.497	2.156	2.933	3.834	4.980	6.621	11.739	15.33	19.40	23.95	28.99	34.49
40	17.32	50.72	0.276	0.624	1.105	1.729	2.490	3.388	4.427	5.751	6.918	9.956	13.557	17.71	22.41	27.66	33.48
50	21.65	56.71	0.311	0.697	1.236	1.933	2.784	3.788	4.950	6.429	7.735	11.152	15.158	19.80	25.05	30.93	37.43
60	25.99	62.12	0.341	0.764	1.354	2.118	3.050	4.149	5.423	7.044	8.437	12.194	16.604	21.69	27.44	33.88	41.00
70	30.32	67.10	0.369	0.825	1.464	2.288	3.294	4.482	5.857	7.609	9.152	13.171	17.935	23.42	29.64	36.60	44.29
80	34.65	71.73	0.394	0.882	1.564	2.445	3.521	4.791	6.262	8.134	9.783	14.080	19.173	25.04	31.69	39.12	47.34
90	38.98	76.08	0.418	0.936	1.659	2.594	3.735	5.082	6.641	8.627	10.377	14.934	20.346	26.56	33.61	41.49	50.21
100	43.31	80.20	0.441	0.986	1.748	2.734	3.937	5.377	7.001	9.094	10.940	15.743	21.437	28.00	35.43	43.74	52.93
120	51.97	87.88	0.489	1.080	1.866	2.996	4.314	5.870	7.671	9.965	11.986	17.250	23.490	30.68	38.83	47.93	58.00
140	60.63	94.89	0.520	1.167	2.069	3.235	4.659	6.349	8.283	10.760	12.942	18.626	25.364	33.13	41.92	51.75	62.63
160	69.29	101.45	0.557	1.248	2.212	3.459	4.981	6.776	8.856	11.504	13.837	19.914	27.117	35.42	44.82	55.33	66.96
180	77.96	107.59	0.588	1.323	2.345	3.668	5.282	7.187	9.392	12.200	14.675	21.119	28.758	37.56	47.53	58.68	71.01
200	86.62	113.41	0.621	1.394	2.472	3.867	5.568	7.575	9.900	12.860	15.469	22.262	30.314	39.59	50.10	61.85	74.85
250	108.50	126.80	0.698	1.560	2.764	4.323	6.225	8.470	11.069	14.379	17.295	24.857	33.893	44.27	56.02	69.16	83.69
300	130.15	138.91	0.761	1.709	3.028	4.736	6.820	9.270	12.126	15.712	18.899	27.268	37.130	48.49	61.37	75.76	91.68
350	150.04	150.04	0.825	1.845	3.271	5.116	7.366	10.022	13.098	17.014	20.465	29.452	40.105	52.38	66.29	81.83	99.03
400	173.60	160.40	0.883	1.973	3.497	5.469	7.875	10.714	14.008	18.189	21.878	31.486	42.874	56.00	70.86	87.48	105.86
450	195.30	170.12	0.935	2.092	3.709	5.801	8.352	11.364	14.851	19.391	23.204	33.394	45.263	59.39	75.16	92.78	112.23
500	216.00	179.33	0.986	2.206	3.909	6.118	8.805	11.979	15.655	20.336	24.460	35.202	47.934	62.60	79.23	97.81	118.36
600	260.11	196.44	1.080	2.416	4.282	6.698	9.645	13.122	17.149	22.276	26.794	38.561	52.508	68.58	86.79	107.14	129.65
700	303.80	212.18	1.167	2.610	4.626	7.235	10.418	14.173	18.523	24.061	28.941	41.650	56.715	74.07	93.74	117.72	149.04
800	347.20	226.84	1.247	2.790	4.945	7.735	11.137	15.152	19.803	25.723	30.940	44.528	60.634	79.19	100.22	123.72	149.71
900	390.60	240.60	1.323	2.959	5.245	8.204	11.813	16.072	20.804	27.284	32.817	47.229	64.312	83.59	106.30	131.22	158.80
1000	434.00	253.61	1.394	3.119	5.529	8.648	12.452	16.941	22.141	28.759	34.592	49.783	67.789	88.94	112.04	138.32	167.38
1200	520.80	277.81	1.527	3.417	6.056	9.473	13.640	18.557	24.260	31.503	37.893	54.534	74.258	96.98	122.74	151.52	183.35
1400	607.60	300.10	1.650	3.691	6.542	10.223	14.734	20.046	26.198	34.031	40.933	58.909	80.216	104.76	132.58	163.67	198.07
1600	694.40	320.80	1.764	3.946	6.993	10.930	15.751	21.429	27.907	36.378	43.757	62.973	85.749	111.99	141.73	174.96	211.73
1800	781.20	340.28	1.872	4.185	7.418	11.503	16.707	22.730	29.706	38.587	46.414	66.796	90.956	118.79	150.34	185.59	224.58
2000	868.00	358.65	1.973	4.411	7.818	12.229	17.609	23.957	31.310	40.670	48.919	70.402	95.867	125.21	158.45	195.61	236.71

## THE SIPHON.

The Siphon is a bent tube of unequal branches, open at both ends, and is used to convey a liquid from a higher to a lower level, over an intermediate point higher than either. Its parallel branches being in a vertical plane and plunged into two bodies of liquid whose upper surfaces are at different levels, the fluid will stand at the same level both within and without each branch of the tube when a vent or small opening is made at the bend. If the air be withdrawn from the siphon through this vent, the water will rise in the branches by the atmospheric pressure without, and when the two columns unite and the vent is closed, the liquid will flow from the upper reservoir as long as the end of the shorter branch of the siphon is below the surface of the liquid in the reservoir.

If the water was free from air the height of the bend above the supply level might be as great as 33 feet.

If  $A$  = area of cross-section of the tube in square feet,  $H$  = the difference in level between the two reservoirs in feet,  $D$  the density of the liquid in pounds per cubic foot, then  $ADH$  measures the intensity of the force which causes the movement of the fluid, and  $V = \sqrt{2gH} = 8.02\sqrt{H}$  is the theoretical velocity, in feet per second, which is reduced by the loss of head for entry and friction, as in other cases of flow of liquids through pipes. In the case of the difference of level being greater than 33 feet, however, the velocity of the water in the shorter leg is limited to that due to a height of 33 feet, or that due to the difference between the atmospheric pressure at the entrance and the vacuum at the bend.

**Long Siphons.** — Prof. Joseph Torrey, in the *Amer. Machinist*, describes a long siphon which was a partial failure.

The length of the pipe was 1792 feet. The pipe was 3 inches diameter, and rose at one point 9 feet above the initial level. The final level was 20 feet below the initial level. No automatic air valve was provided. The highest point in the siphon was about one third the total distance from the pond and nearest the pond. At this point a pump was placed, whose mission was to fill the pipe when necessary. This siphon would flow for about two hours and then cease, owing to accumulation of air in the pipe. When in full operation it discharged 431½ gallons per minute. The theoretical discharge from such a sized pipe with the specified head is 551½ gallons per minute.

**Siphon on the Water-supply of Mount Vernon, N. Y.** (*Eng'g News*, May 4, 1893.) — A 12-inch siphon, 925 feet long, with a maximum lift of 22.12 feet and a 45° change in alignment, was put in use in 1892 by the New York City Suburban Water Co. At its summit the siphon crosses a supply main, which is tapped to charge the siphon. The air-chamber at the siphon is 12 inches by 16 feet long. A ½-inch tap and cock at the top of the chamber provide an outlet for the collected air.

It was found that the siphon with air-chamber as described would run until 125 cubic feet of air had gathered, and that this took place only half as soon with a 14-foot lift as with the full lift of 22.12 feet. The siphon will operate about 12 hours without being recharged, but more water can be gotten over by charging every six hours. It can be kept running 23 hours out of 24 with only one man in attendance. With the siphon as described above it is necessary to close the valves at each end of the siphon to recharge it. It has been found by weir measurements that the discharge of the siphon before air accumulates at the summit is practically the same as through a straight pipe.

**A successful siphon** is described by R. S. Hale in *Jour. Assoc. Eng. Soc.*, 1900. A 2-in. galvanized pipe had been used, and it had been necessary to open a waste-pipe and thus secure a continuous flow in order to keep the siphon in operation. The trouble seemed to be due to very small air leaks in the joints. When the 2-in. iron pipe was replaced by a 1-in. lead pipe, the siphon was entirely successful. The maximum rise of the pipe above the level of the pond was 12 ft., the discharge about 350 ft. below the level, and the length 500 ft.



**VELOCITY OF WATER IN OPEN CHANNELS.**

**Irrigation Canals.**—The minimum mean velocity required to prevent the deposit of silt or the growth of aquatic plants is in Northern India taken at 1½ feet per second. It is stated that in America a higher velocity is required for this purpose, and it varies from 2 to 3½ feet per second. The maximum allowable velocity will vary with the nature of the soil of the bed. A sandy bed will be disturbed if the velocity exceeds 3 feet per second. Good loam with not too much sand will bear a velocity of 4 feet per second. The Cavour Canal in Italy, over a gravel bed, has a velocity of about 5 per second. (Flynn's "Irrigation Canals.")

**Mean Surface and Bottom Velocities.**—According to the formula of Bazin.

$$v = v_{\max} - 25.4 \sqrt{rs}; \quad v = v_b + 10.87 \sqrt{rs}.$$

∴  $v_b = v - 10.87 \sqrt{rs}$ , in which  $v$  = mean velocity in feet per second,  $v_{\max}$  = maximum surface velocity in feet per second,  $v_b$  = bottom velocity in feet per second,  $r$  = hydraulic mean depth in feet = area of cross-section in square feet divided by wetted perimeter in feet,  $s$  = sine of slope.

The least velocity, or that of the particles in contact with the bed, is almost as much less than the mean velocity as the greatest velocity is greater than the mean.

Rankine states that in ordinary cases the velocities may be taken as bearing to each other nearly the proportions of 3, 4, and 5. In very slow currents they are nearly as 2, 3, and 4.

**Safe Bottom and Mean Velocities.**—Ganguillet & Kutter give the following table of safe bottom and mean velocities in channels, calculated from the formula  $v = v_b + 10.87\sqrt{rs}$ :

Material of Channel.	Safe Bottom Velocity $v_b$ , in Feet per Second.	Mean Velocity $v$ , in Feet per Second.
Soft brown earth.....	0.249	0.328
Soft loam.....	0.499	0.656
Sand.....	1.000	1.312
Gravel.....	1.998	2.625
Pebbles.....	2.999	3.938
Broken stone, flint.....	4.003	5.579
Conglomerate, soft slate....	4.988	6.564
Stratified rock.....	6.006	8.204
Hard rock.....	10.009	13.127

Ganguillet & Kutter state that they are unable for want of observations to judge how far these figures are trustworthy. They consider them to be rather disproportionately small than too large, and therefore recommend them more confidently.

Water flowing at a high velocity and carrying large quantities of silt is very destructive to channels, even when constructed of the best masonry.

**Resistance of Soils to Erosion by Water.**—W. A. Burr, *Eng'g News*, Feb. 8, 1894, gives a diagram showing the resistance of various soils to erosion by flowing water.

Experiments show that a velocity greater than 1.1 feet per second will erode sand, while pure clay will stand a velocity of 7.35 feet per second. The greater the proportion of clay carried by any soil, the higher the permissible velocity. Mr. Burr states that experiments have shown that the line describing the power of soils to resist erosion is parabolic. From his diagram the following figures are selected as representing different classes of soils:

Pure sand resists erosion by flow of.....	1.1	feet per second.
Sandy soil, 15% clay.....	1.2	" "
Sandy loam, 40% clay.....	1.8	" "
Loamy soil, 65% clay.....	3.0	" "
Clay loam, 85% clay.....	4.8	" "
Agricultural clay, 95% clay.....	6.2	" "
Clay.....	7.35	" "

**Abrading and Transporting Power of Water.**—Prof. J. LeConte, in his "Elements of Geology," states:

The erosive power of water, or its power of overcoming cohesion, varies as the square of the velocity of the current.

The transporting power of a current varies as the sixth power of the velocity. \* \* \* If the velocity therefore be increased ten times, the transporting power is increased 1,000,000 times. A current running three feet per second, or about two miles per hour, will bear fragments of stone of the size of a hen's egg, or about three ounces weight. A current of ten miles an hour will bear fragments of one and a half tons, and a torrent of twenty miles an hour will carry fragments of 100 tons.

The transporting power of water must not be confounded with its erosive power. The resistance to be overcome in the one case is weight, in the other, cohesion; the latter varies as the square: the former as the sixth power of the velocity.

In many cases of removal of slightly cohering material, the resistance is a mixture of these two resistances, and the power of removing material will vary at some rate between  $v^2$  and  $v^6$ .

Baldwin Latham has found that in order to prevent deposits of sewage silt in small sewers or drains, such as those from 6 inches to 9 inches diameter, a mean velocity of not less than 3 feet per second should be produced. Sewers from 12 to 24 inches diameter should have a velocity of not less than  $2\frac{1}{2}$  feet per second, and in sewers of larger dimensions in no case should the velocity be less than 2 feet per second.

The specific gravity of the materials has a marked effect upon the mean velocities necessary to move them. T. E. Blackwell found that coal of a sp. gr. of 1.26 was moved by a current of from 1.25 to 1.50 ft. per second, while stones of a sp. gr. of 2.32 to 3.00 required a velocity of 2.5 to 2.75 ft. per second.

Chailly gives the following formula for finding the velocity required to move rounded stones or shingle:

$$v = 5.67 \sqrt{ag},$$

in which  $v$  = velocity of water in feet per second,  $a$  = average diameter in feet of the body to be moved,  $g$  = its specific gravity.

Geo. Y. Wisner, *Eng'g News*, Jan. 10, 1895, doubts the general accuracy of statements made by many authorities concerning the rate of flow of a current and the size of particles which different velocities will move. He says:

The scouring action of any river, for any given rate of current, must be an inverse function of the depth. The fact that some engineer has found that a given velocity of current on some stream of unknown depth will move sand or gravel has no bearing whatever on what may be expected of currents of the same velocity in streams of greater depths. In channels 3 to 5 ft. deep a mean velocity of 3 to 5 ft. per second may produce rapid scouring, while in depths of 18 ft. and upwards current velocities of 6 to 8 ft. per second often have no effect whatever on the channel bed.

**Frictional Resistance of Surfaces Moved in Water.** (*Ency. Brit.*, 11th ed. Vol. xiv, p. 58.)—Froude's experiments were made by pulling boards 19 in. wide,  $\frac{3}{8}$  in. thick, finely sharpened at both ends, set edge-wise in water. The following table gives: A, the power of the speed to which the resistance is proportional; B, the mean resistance in pounds per sq. ft. of the whole surface of a board of the lengths stated in the table, at the standard speed of 10 ft. per second.

Surface.	Length of Surface, in Feet.							
	2 ft.		8 ft.		20 ft.		50 ft.	
	A	B	A	B	A	B	A	B
Varnish.....	2.00	0.41	1.85	0.325	1.85	0.278	1.83	0.226
Paraffin.....	.....	0.38	1.94	0.314	1.93	0.271	.....	.....
Tinfoil.....	2.16	0.30	1.99	0.278	1.90	0.262	1.83	0.232
Calico.....	1.93	0.87	1.92	0.626	1.89	0.531	1.87	0.423
Fine Sand....	2.00	0.81	2.00	0.583	2.00	0.480	2.06	0.337
Medium Sand..	2.00	0.90	2.00	0.625	2.00	0.534	2.00	0.456
Coarse Sand...	2.00	1.10	2.00	0.714	2.00	0.588	.....	.....

Unwin's experiments (*Proc. Inst. Civ. Engrs.*, lxxx) were made with disks 10, 15, and 20 in. diam. rotated in water by a vertical shaft, in chambers 22 in. diam., and 3, 6, and 12 in. deep. In all cases the fric-

tional resistances increased a little as the chamber was made larger. The friction depends not only on the surface of the disk, but to some extent on the surface of the chamber in which it rotates. For the smoother surface the friction varied as the 1.85 power of the velocity. For rougher surfaces it varied as the 1.9 to the 2.1 power. The friction decreased 18 per cent with increase of temperature from 41° to 130° F. The resistances in pounds per sq. ft. at 10 ft. per second were as follows for different surfaces: Bright brass, 0.202 to 0.229; Varnish, 0.220 to 0.233; Fine sand, 0.339; Very coarse sand, 0.587 to 0.715. The results agree fairly well with those obtained by Froude with planks 50 ft. long.

**Grade of Sewers.** — The following empirical formula is given in Baumeister's "Cleaning and Sewerage of Cities," for the minimum grade for a sewer of clear diameter equal to  $d$  inches, and either circular or oval in section:

$$\text{Minimum grade, in per cent} = \frac{100}{5d + 50}.$$

As the lowest limit of grades which can be flushed, 0.1 to 0.2 per cent may be assumed for sewers which are sometimes dry, while 0.3 per cent is allowable for the trunk sewers in large cities. The sewers should run dry as rarely as possible.

## MEASUREMENT OF FLOWING WATER.

**Piezometer.** — If a vertical or oblique tube be inserted into a pipe containing water under pressure, the water will rise in the former, and the vertical height to which it rises will be the head producing the pressure at the point where the tube is attached. Such a tube is called a piezometer or pressure measure. If the water in the piezometer falls below its proper level it shows that the pressure in the main pipe has been reduced by an obstruction between the piezometer and the reservoir. If the water rises above its proper level, it indicates that the pressure there has been increased by an obstruction beyond the piezometer.

If we imagine a pipe full of water to be provided with a number of piezometers, then a line joining the tops of the columns of water in them is the hydraulic grade-line.

**Pitot Tube Gauge.** — The Pitot tube is used for measuring the velocity of fluids in motion. It has been used with great success in measuring the flow of natural gas. (S. W. Robinson, Report Ohio Geol. Survey, 1890.) (See also *Van Nostrand's Mag.*, vol. xxxv.) It is simply a tube so bent that a short leg extends into the current of fluid flowing from a tube, with the plane of the entering orifice opposed at right angles to the direction of the current. The pressure caused by the impact of the current is transmitted through the tube to a pressure-gauge of any kind, such as a column of water or of mercury, or a Bourdon spring-gauge. From the pressure thus indicated and the known density and temperature of the flowing gas is obtained the head corresponding to the pressure, and from this the velocity. In a modification of the Pitot tube described by Prof. Robinson, there are two tubes inserted into the pipe conveying the gas, one of which has the plane of the orifice at right angles to the current, to receive the static pressure plus the pressure due to impact; the other has the plane of its orifice parallel to the current, so as to receive the static pressure only. These tubes are connected to the legs of a  $U$  tube partly filled with mercury, which then registers the difference in pressure in the two tubes, from which the velocity may be calculated. Comparative tests of Pitot tubes with gas-meters, for measurement of the flow of natural gas, have shown an agreement within 3%.

It appears from experiments made by W. M. White, described in a paper before the Louisiana Eng'g Socy., 1901, by Williams, Hubbell and Finkel (*Trans. A. S. C. E.*, 1901), and by W. B. Gregory (*Trans. A. S. M. E.*, 1903), that in the formula for the Pitot tube,  $V = c\sqrt{2gH}$ , in which  $V$  is the velocity of the current in feet per second,  $H$  the head in feet of the fluid corresponding to the pressure measured by the tube, and  $c$  an experimental coefficient,  $c = 1$  when the plane at the point of



the tube is exactly at right angles with the direction of the current, and when the static pressure is correctly measured. The total pressure produced by a jet striking an extended plane surface at right angles to it, and escaping parallel to the plate, equals twice the product of the area of the jet into the pressure calculated from the "head due the velocity," and for this case  $H = 2 \times V^2/2g$  instead of  $V^2/2g$ ; but as found in White's experiments the maximum pressure at a point on the plate exactly opposite the jet corresponds to  $h = V^2/2g$ . Experiments made with four different shapes of nozzles placed under the center of a falling stream of water showed that the pressure produced was capable of sustaining a column of water almost exactly equal to the height of the source of the falling water.

Tests by J. A. Knesche (*Indust. Eng'g*, Nov., 1909), in which a Pitot tube was inserted in a 4-in. water pipe, gave  $C$  = about 0.77 for velocities of 2.5 to 8 ft. per sec., and smaller values for lower velocities. He holds that the coefficient of a tube should be determined by experiment before its readings can be considered accurate.

For a brief discussion of various theories of the Pitot tube see *Eng'g News*, April 17, June 5, and July 31, 1913.

**Maximum and Mean Velocities in Pipes.**—Williams, Hubbell and Fenkel (*Trans. A. S. C. E.*, 1901) found a ratio of 0.84 between the mean and the maximum velocities of water flowing in closed circular conduits, under normal conditions, at ordinary velocities; whereby observations of velocity taken at the center under such conditions, with a properly rated Pitot tube, may be relied on to give results within 3% of correctness.

**The Venturi Meter**, invented by Clemens Herschel, and described in a pamphlet issued by the Builders' Iron Foundry of Providence, R.I., is named from Venturi, who first called attention, in 1796, to the relation between the velocities and pressures of fluids when flowing through converging and diverging tubes. It consists of two parts—the tube, through which the water flows, and the recorder, which registers the quantity of water that passes through the tube. The tube takes the shape of two truncated cones joined in their smallest diameters by a short throat-piece. At the up-stream end and at the throat there are pressure-chambers, at which points the pressures are taken.

The action of the tube is based on that property which causes the small section of a gently expanding frustum of a cone to receive, without material resultant loss of head, as much water at the smallest diameter as is discharged at the large end, and on that further property which causes the pressure of the water flowing through the throat to be less, by virtue of its greater velocity, than the pressure at the up-stream end of the tube, each pressure being at the same time a function of the velocity at that point and of the hydrostatic pressure which would obtain were the water motionless within the pipe.

The recorder is connected with the tube by pressure-pipes which lead to it from the chambers surrounding the up-stream end and the throat of the tube. It may be placed in any convenient position within 1000 feet of the meter. It is operated by a weight and clockwork. The difference of pressure or head at the entrance and at the throat of the meter is balanced in the recorder by the difference of level in two columns of mercury in cylindrical receivers, one within the other. The inner carries a float, the position of which is indicative of the quantity of water flowing through the tube. By its rise and fall the float varies the time of contact between an integrating drum and the counters by which the successive readings are registered.

There is no limit to the sizes of the meters nor the quantity of water that may be measured. Meters with 24-inch, 36-inch, 48-inch, and even 20-foot tubes can be readily made.

**Measurement by Venturi Tubes.** (*Trans. A. S. C. E.*, Nov., 1887, and Jan., 1888.)—Mr. Herschel recommends the use of a Venturi tube, inserted in the force-main of the pumping engine, for determining the quantity of water discharged. Such a tube applied to a 24-inch main has a total length of about 20 feet. At a distance of 4 feet from the end nearest the engine the inside diameter of the tube is contracted to a throat having a diameter of about 8 inches. A pressure-gauge is attached to each of two chambers, the one surrounding and communicating with the entrance or main pipe, the other with the throat. According to experiments made

upon two tubes of this kind, one 4 in. in diameter at the throat and 12 in. at the entrance, and the other about 36 in. in diameter at the throat and 9 feet at its entrance, the quantity of water which passes through the tube is very nearly the theoretical discharge through an opening having an area equal to that of the throat, and a velocity which is that due to the difference in head shown by the two gauges. Mr. Herschel states that the coefficient for these two widely-varying sizes of tubes and for a wide range of velocity through the pipe, was found to be within two per cent, either way, of 98%. In other words, the quantity of water flowing through the tube per second is expressed within two per cent by the formula  $W = 0.98 \times A \times \sqrt{2gh}$ , in which  $A$  is the area of the throat of the tube,  $h$  the head, in feet, corresponding to the difference in the pressure of the water entering the tube and that found at the throat, and  $g = 32.16$ .

**Coefficient of Flow in Venturi Meters.**—(Allen Hazen, *Eng. News*, July 31, 1913.) The formula for flow in a Venturi meter is

$$Q = K \times C \frac{d^2}{\sqrt{\left(1 - \frac{d}{D}\right)^4}} \sqrt{h}$$

$d$  and  $D$  respectively are diameters of the throat and entrance, in inches,  $h$  is the head on the meter,  $C$  a coefficient which depends on the frictional resistance and has an average value of very close to 0.99 for ordinary waterworks conditions.  $K = 28,276$  if  $Q$  is the quantity in U. S. gallons per 24 hours and  $h$  is measured in feet of water. If  $C = 0.99$  then  $KC = 27,993$  for  $h$  in feet of water, 8081 if  $h$  is in inches of water, and 28,684 if  $h$  is in inches of mercury. For  $Q$  in cubic feet per second, divide these figures by 646,315 giving respectively  $KC = 0.04331$ , 0.01250 and 0.04438.

**Measurement of Discharge of Pumping-engines by means of Nozzles.** (*Trans. A. S. M. E.*, xii, 575.)—The measurement of water by computation from its discharge through orifices, or through the nozzles of fire-hose, furnishes a means of determining the quantity of water delivered by a pumping-engine which can be applied without much difficulty. John R. Freeman, *Trans. A. S. C. E.*, Nov., 1889, describes a series of experiments covering a wide range of pressures and sizes, and the results showed that the coefficient of discharge for a smooth nozzle of ordinary good form was within one-half of one per cent, either way, of 0.977; the diameter of the nozzle being accurately calipered, and the pressures being determined by means of an accurate gauge attached to a suitable piezometer at the base of the play-pipe.

In order to use this method for determining the quantity of water discharged by a pumping-engine, it would be necessary to provide a pressure-box, to which the water would be conducted, and attach to the box as many nozzles as would be required to carry off the water. According to Mr. Freeman's estimate, four 1 1/4-inch nozzles, thus connected, with a pressure of 80 lbs. per square inch, would discharge the full capacity of a two-and-a-half-million engine. He also suggests the use of a portable apparatus with a single opening for discharge, consisting essentially of a Siamese nozzle, so-called, the water being carried to it by three or more lines of fire-hose.

To insure reliability for these measurements, it is necessary that the shut-off valve in the force-main, or the several shut-off valves, should be tight, so that all the water discharged by the engine may pass through the nozzles.

**The Lea V-Notch Recording Water Meter** is described by D. Robert Yarnall in *Trans. A. S. M. E.*, 1912. It is extensively used in large power plants for recording the flow of boiler feed water. It consists of a metering tank or flume from which the water passes over a 90° V-notch into a catch basin below, the height of the water above the notch being recorded on a clock-driven paper chart which revolves once in 24 hours. The formula for the 90° V-notch is cu. ft. per min. =  $0.305H \sqrt{H}$ , in which  $H$  is the height in inches of the still water behind the notch measured above the level of the bottom of the notch. Tests by Mr. Yarnall of a recording meter made on this principle showed an

average error of 0.5%. The Yarnall-Waring Co., Philadelphia, makers of the meter give the following figures for the flow of water in pounds per hour corresponding to different heights of water in inches above the notch:

Height, in.:	1	2	3	4	5	6	7	8
Flow, lb. per hour:	1,140	6,480	17,830	36,610	63,940	100,860	148,290	207,060

Height, in.:	9	10	11	12	13	14	15
Flow, lb. per hour:	277,960	361,740	459,030	568,720	694,710	836,110	993,510

**Flow through Rectangular Orifices.** (Approximate. See p. 727.)

**CUBIC FEET OF WATER DISCHARGED PER MINUTE THROUGH AN ORIFICE ONE INCH SQUARE, UNDER ANY HEAD OF WATER FROM 3 TO 72 INCHES.**

For any other orifice multiply by its area in square inches.

Formula,  $Q' = 0.624 \sqrt{h''} \times a$ .  $Q'$  = cu. ft. per min.;  $a$  = area in sq. in.

Heads in inches.	Cubic Feet Discharged per min.	Heads in inches.	Cubic Feet Discharged per min.	Heads in inches.	Cubic Feet Discharged per min.	Heads in inches.	Cubic Feet Discharged per min.	Heads in inches.	Cubic Feet Discharged per min.	Heads in inches.	Cubic Feet Discharged per min.	Heads in inches.	Cubic Feet Discharged per min.
3	1.12	13	2.20	23	2.90	33	3.47	43	3.95	53	4.39	63	4.78
4	1.27	14	2.28	24	2.97	34	3.52	44	4.00	54	4.42	64	4.81
5	1.40	15	2.36	25	3.03	35	3.57	45	4.05	55	4.46	65	4.85
6	1.52	16	2.43	26	3.08	36	3.62	46	4.09	56	4.52	66	4.89
7	1.64	17	2.51	27	3.14	37	3.67	47	4.12	57	4.55	67	4.92
8	1.75	18	2.58	28	3.20	38	3.72	48	4.18	58	4.58	68	4.97
9	1.84	19	2.64	29	3.25	39	3.77	49	4.21	59	4.63	69	5.00
10	1.94	20	2.71	30	3.31	40	3.81	50	4.27	60	4.65	70	5.03
11	2.03	21	2.78	31	3.36	41	3.86	51	4.30	61	4.72	71	5.07
12	2.12	22	2.84	32	3.41	42	3.91	52	4.34	62	4.74	72	5.09

**Measurement of an Open Stream by Velocity and Cross-section.** — Measure the depth of the water at from 6 to 12 points across the stream at equal distances between. Add all the depths in feet together and divide by the number of measurements made; this will be the average depth of the stream, which multiplied by its width will give its area or cross-section. Multiply this by the velocity of the stream in feet per minute, and the result will be the discharge in cubic feet per minute of the stream.

The velocity of the stream can be found by laying off 100 feet of the bank and throwing a float into the middle, noting the time taken in passing over the 100 ft. Do this a number of times and take the average; then, dividing this distance by the time gives the velocity at the surface. As the top of the stream flows faster than the bottom or sides — the average velocity being about 83% of the surface velocity at the middle — it is convenient to measure a distance of 120 feet for the float and reckon it as 100



**Miner's Inch Measurements.** (Pelton Water Wheel Co.)

The cut, Fig.149, shows the form of measuring-box ordinarily used, and the following table gives the discharge in cubic feet per minute of a miner's inch of water, as measured under the various heads and different lengths and heights of apertures used in California.

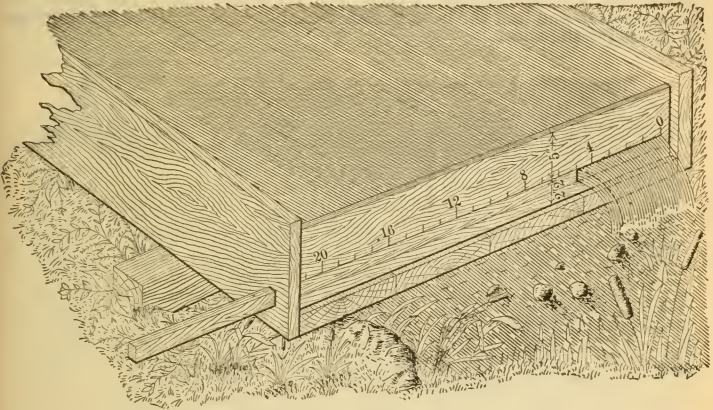

FIG. 149.

Length of Opening in inches.	Openings 2 Inches High.			Openings 4 Inches High.		
	Head to Center, 5 inches.	Head to Center, 6 inches.	Head to Center, 7 inches.	Head to Center, 5 inches.	Head to Center, 6 inches.	Head to Center, 7 inches.
	Cu. ft.	Cu. ft.	Cu. ft.	Cu. ft.	Cu. ft.	Cu. ft.
4	1.348	1.473	1.589	1.320	1.450	1.570
6	1.355	1.480	1.596	1.336	1.470	1.595
8	1.359	1.484	1.600	1.344	1.481	1.608
10	1.361	1.485	1.602	1.349	1.487	1.615
12	1.363	1.487	1.604	1.352	1.491	1.620
14	1.364	1.488	1.604	1.354	1.494	1.623
16	1.365	1.489	1.605	1.356	1.496	1.626
18	1.365	1.489	1.606	1.357	1.498	1.628
20	1.365	1.490	1.606	1.359	1.499	1.630
22	1.366	1.490	1.607	1.359	1.500	1.631
24	1.366	1.490	1.607	1.360	1.501	1.632
26	1.366	1.490	1.607	1.361	1.502	1.633
28	1.367	1.491	1.607	1.361	1.503	1.634
30	1.367	1.491	1.608	1.362	1.503	1.635
40	1.367	1.492	1.608	1.363	1.505	1.637
50	1.368	1.493	1.609	1.364	1.507	1.639
60	1.368	1.493	1.609	1.365	1.508	1.640
70	1.368	1.493	1.609	1.365	1.508	1.641
80	1.368	1.493	1.609	1.366	1.509	1.641
90	1.369	1.493	1.610	1.366	1.509	1.641
100	1.369	1.494	1.610	1.366	1.509	1.642

NOTE. — The apertures from which the above measurements were obtained were through material 1 1/4 inches thick, and the lower edge 2 inches above the bottom of the measuring-box, thus giving full contraction.

**Flow of Water Over Weirs. Weir Dam Measurement.** (Pelton Water Wheel Co.) — Place a board or plank in the stream, as shown in the sketch, at some point where a pond will form above. The length of the notch in the dam should be from two to four times its depth for small quantities and longer for large quantities. The edges of the notch should be beveled toward the intake side, as shown. The overfall below the notch should not be less than twice its depth. Francis says a fall below the crest equal to one-half the head is sufficient, but there must be a free access of air under the sheet.

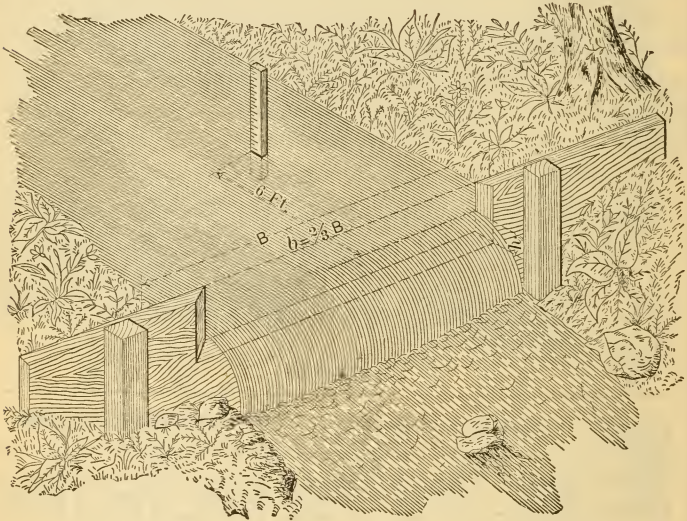

FIG. 150.

In the pond, about 6 ft. above the dam, drive a stake, and then obstruct the water until it rises precisely to the bottom of the notch and mark the stake at this level. Then complete the dam so as to cause all the water to flow through the notch, and, after time for the water to settle, mark the stake again for this new level. If preferred the stake can be driven with its top precisely level with the bottom of the notch and the depth of the water be measured with a rule after the water is flowing free, but the marks are preferable in most cases. The stake can then be withdrawn; and the distance between the marks is the theoretical depth of flow corresponding to the quantities in the weir table on the following page.

#### Francis's Formulae for Weirs.

$Q$  = discharge in cubic feet per second,  $L$  = length of the weir,  $H$  = depth of water on the weir,  $h$  = head due the velocity of approach =  $V^2 \div 64.3$ ; dimensions in feet, velocity in feet per second.

Francis's formula,  $Q = 3.33(L - 0.2H) \times H^{3/2}$ .

This formula applies to weirs having perfect contraction at each end and the velocity of approach negligible. When the velocity of approach is considered the formula is  $Q = 3.33(L - 0.2H) \times [(H + h)^{3/2} - h^{3/2}]$ . The Francis formula is not applicable when the depth on the weir exceeds one-third of the length nor to very small depths. The distance from the side of the canal to the end of the weir should not be less than three times the depth on the weir.

With both end contractions suppressed the term  $0.2 H$  is omitted from the formula, and with one end contraction suppressed it becomes  $0.1 H$ .

If  $Q'$  = discharge in cubic feet per minute, and  $l'$  and  $h'$  are taken in inches, the first of the above formulæ reduces to  $Q' = 0.4 l' h'^{3/2}$ . From this formula the following table is calculated. The values are sufficiently accurate for ordinary computations of water-power for weirs without end contraction, that is, for a weir the full width of the channel of approach. For weirs with full end contraction multiply the values taken from the table by the length of the weir crest in inches less 0.2 times the head in inches, to obtain the discharge.

### Weir Table.

GIVING CUBIC FEET OF WATER PER MINUTE THAT WILL FLOW OVER A WEIR ONE INCH WIDE AND FROM  $1/8$  TO  $207/8$  INCHES DEEP.

For other widths multiply by the width in inches.

Depth.		1/8 in.	1/4 in.	3/8 in.	1/2 in.	5/8 in.	3/4 in.	7/8 in.
in.	cu. ft.	cu. ft.	cu. ft.	cu. ft.	cu. ft.	cu. ft.	cu. ft.	cu. ft.
0	.00	.01	.05	.09	.14	.19	.26	.32
1	.40	.47	.55	.64	.73	.82	.92	1.02
2	1.13	1.23	1.35	1.46	1.58	1.70	1.82	1.95
3	2.07	2.21	2.34	2.48	2.61	2.76	2.90	3.05
4	3.20	3.35	3.50	3.66	3.81	3.97	4.14	4.30
5	4.47	4.64	4.81	4.98	5.15	5.33	5.51	5.69
6	5.87	6.06	6.25	6.44	6.62	6.82	7.01	7.21
7	7.40	7.60	7.80	8.01	8.21	8.42	8.63	8.83
8	9.05	9.26	9.47	9.69	9.91	10.13	10.35	10.57
9	10.80	11.02	11.25	11.48	11.71	11.94	12.17	12.41
10	12.64	12.88	13.12	13.36	13.60	13.85	14.09	14.34
11	14.59	14.84	15.09	15.34	15.59	15.85	16.11	16.36
12	16.62	16.88	17.15	17.41	17.67	17.94	18.21	18.47
13	18.74	19.01	19.29	19.56	19.84	20.11	20.39	20.67
14	20.95	21.23	21.51	21.80	22.08	22.37	22.65	22.94
15	23.23	23.52	23.82	24.11	24.40	24.70	25.00	25.30
16	25.60	25.90	26.20	26.50	26.80	27.11	27.42	27.72
17	28.03	28.34	28.65	28.97	29.28	29.59	29.91	30.22
18	30.54	30.86	31.18	31.50	31.82	32.15	32.47	32.80
19	33.12	33.45	33.78	34.11	34.44	34.77	35.10	35.44
20	35.77	36.11	36.45	36.78	37.12	37.46	37.80	38.15

When the velocity of the approaching water is less than  $1/2$  foot per second, the result obtained by the table is fairly accurate. When the velocity of approach is greater than  $1/2$  foot per second, a correction should be applied, see page 727.

For more accurate computations, the coefficients of flow of Hamilton Smith, Jr., or of Bazin should be used. In Smith's *Hydraulics* will be found a collection of results of experiments on orifices and weirs of various shapes made by many different authorities, together with a discussion of their several formulæ. (See also Trautwine's *Pocket Book*, Unwin's *Hydraulics*, Church's *Mechanics of Engineering*, Merriman's *Hydraulics*, Williams and Hazen's *Hydraulic Tables*, Hughes and Safford's *Hydraulics*, and Weir Experiments, Coefficients and Formulas, by R. E. Horton, Water Supply and Irrigation paper No. 200 of the U. S. Geological Survey.)

**Bazin's Experiments.**—M. Bazin (*Annales des Ponts et Chaussées*, Oct., 1888, translated by Marichal and Trautwine, *Proc. Engrs. Club of Phila.*, Jan., 1890) made an extensive series of experiments with a sharp-crested weir without lateral contraction, the air being admitted freely behind the falling sheet, and found values of  $m$  varying from 0.42 to 0.50, with variations of the length of the weir from  $19\frac{3}{4}$  to  $78\frac{3}{4}$  in., of the height of the crest above the bottom of the channel from 0.79 to 2.46 ft.,



and of the head from 1.97 to 23.62 in. From these experiments he deduces the following formula:

$$Q = \left[ 0.425 + 0.21 \left( \frac{H}{P+H} \right)^2 \right] LH \sqrt{2gH},$$

in which  $P$  is the height in feet of the crest of the weir above the bottom of the channel of approach,  $L$  the length of the weir,  $H$  the head, both in feet, and  $Q$  the discharge in cu. ft. per sec. This formula, says M. Bazin, is entirely practical where errors of 2% to 3% are admissible. The following table is condensed from M. Bazin's paper:

VALUES OF THE COEFFICIENT  $m$  IN THE FORMULA  $Q = mLH \sqrt{2gH}$ , FOR A SHARP-CRESTED WEIR WITHOUT LATERAL CONTRACTION; THE AIR BEING ADMITTED FREELY BEHIND THE FALLING SHEET.

Head, $H$ .		Height of Crest of Weir Above Bed of Channel.									
		Feet...0.66 Inches 7.87	0.98 11.81	1.31 15.75	1.64 19.69	1.97 23.62	2.62 31.50	3.28 39.38	4.92 59.07	6.56 78.76	$\infty$ $\infty$
Ft.	In.	$m$	$m$	$m$	$m$	$m$	$m$	$m$	$m$	$m$	$m$
0.164	1.97	0.458	0.453	0.451	0.450	0.449	0.449	0.449	0.448	0.448	0.4481
0.230	2.76	0.455	0.448	0.445	0.443	0.442	0.441	0.440	0.440	0.439	0.4391
0.295	3.54	0.457	0.447	0.442	0.440	0.438	0.436	0.436	0.435	0.434	0.4340
0.394	4.72	0.462	0.448	0.442	0.438	0.436	0.433	0.432	0.430	0.430	0.4291
0.525	6.30	0.471	0.453	0.444	0.438	0.435	0.431	0.429	0.427	0.426	0.4246
0.656	7.87	0.480	0.459	0.447	0.440	0.436	0.431	0.428	0.425	0.423	0.4215
0.787	9.45	0.488	0.465	0.452	0.444	0.438	0.432	0.428	0.424	0.422	0.4194
0.919	11.02	0.496	0.472	0.457	0.448	0.441	0.433	0.429	0.424	0.422	0.4181
1.050	12.60	.....	0.478	0.462	0.452	0.444	0.436	0.430	0.424	0.421	0.4168
1.181	14.17	.....	0.483	0.467	0.456	0.448	0.438	0.432	0.424	0.421	0.4156
1.312	15.75	.....	0.489	0.472	0.459	0.451	0.440	0.433	0.424	0.421	0.4144
1.444	17.32	.....	0.494	0.476	0.463	0.454	0.442	0.435	0.425	0.421	0.4134
1.575	18.90	.....	.....	0.480	0.467	0.457	0.444	0.436	0.425	0.421	0.4122
1.706	20.47	.....	.....	0.483	0.470	0.460	0.446	0.438	0.426	0.421	0.4112
1.837	22.05	.....	.....	0.487	0.473	0.463	0.448	0.439	0.427	0.421	0.4101
1.969	23.62	.....	.....	0.490	0.476	0.466	0.451	0.441	0.427	0.421	0.4092

A comparison of the results of this formula with those of experiments, says M. Bazin, justifies us in believing that, except in the unusual case of a very low weir (which should always be avoided), the preceding table will give the coefficient  $m$  in all cases within 1%; provided, however, that the arrangements of the standard weir are exactly reproduced. It is especially important that the admission of the air behind the falling sheet be perfectly assured. If this condition is not complied with,  $m$  may vary within much wider limits. The type adopted gives the least possible variation in the coefficient.

**Triangular Weir.**—For the formula of the triangular or V-notch weir, see the Lea Recorder, page 759.

**The Cippoletti, or Trapezoidal Weir.**—Cippoletti found that by using a trapezoidal weir with the sides inclined 1 horizontal to 4 vertical, with end contraction, the discharge is equal to that of a rectangular weir without end contraction (that is with the width of the weir equal to the width of the channel) and is represented by the simple formula  $Q = 3.367 LH^{3/2}$ . A. D. Flinn and C. W. D. Dyer (*Trans. A. S. C. E.*, 1894), in experiments with a trapezoidal weir, with values of  $L$  from 3 to 9 ft. and of  $H$  from 0.24 to 1.40 ft., found the value of the coefficient to average 3.334, the water being measured by a rectangular weir and the results being computed by Francis's formula, and 3.354 when Smith's formula was used. They conclude that Cippoletti's formula when applied to a properly constructed trapezoidal weir will give the discharge with an error due to combined inaccuracies, not greater than 1%.

## WATER-POWER.

**Power of a Fall of Water — Efficiency.** — The gross power of a fall of water is the product of the weight of water discharged in a unit of time into the total head, i.e., the difference of vertical elevation of the upper surface of the water at the points where the fall in question begins and ends. The term "head" used in connection with water-wheels is the difference in height from the surface of the water in the wheel-pit to the surface in the pen-stock when the wheel is running.

If  $Q$  = cubic feet of water discharged per second,  $D$  = weight of a cubic foot of water = 62.36 lbs. at 60° F.,  $H$  = total head in feet; then

$DQH$  = gross power in foot-pounds per second,  
and  $DQH \div 550 = 0.1134 QH$  = gross horse-power.

If  $Q'$  is taken in cubic feet per minute,  $H.P. = \frac{Q'H \times 62.36}{33,000} = .00189 Q'H$ .

A water-wheel or motor of any kind cannot utilize the whole of the head  $H$ , since there are losses of head at both the entrance to and the exit from the wheel. There are also losses of energy due to friction of the water in its passage through the wheel. The ratio of the power developed by the wheel to the gross power of the fall is the efficiency of the wheel. For 75% efficiency, net horse-power =  $0.00142 Q'H = \frac{Q'H}{706}$ .

A head of water can be made use of in one or other of the following ways, viz.:

- 1st. By its weight, as in the water-balance and in the overshot-wheel.
- 2d. By its pressure, as in turbines and in the hydraulic engine, hydraulic press, crane, etc.
- 3d. By its impulse, as in the undershot-wheel, and in the Pelton wheel.
- 4th. By a combination of the above.

**Horse-power of a Running Stream.** — The gross horse-power is  $H.P. = QH \times 62.36 \div 550 = 0.1134 QH$ , in which  $Q$  is the discharge in cubic feet per second actually impinging on the float or bucket, and  $H$  = theoretical head due to the velocity of the stream =  $\frac{v^2}{2g} = \frac{v^2}{64.4}$ , in which  $v$  is the velocity in feet per second. If  $Q'$  be taken in cubic feet per minute,  $H.P. = 0.00189 Q'H$ .

Thus, if the floats of an undershot-wheel driven by a current alone be 5 feet  $\times$  1 foot, and the velocity of stream = 210 ft. per minute, or  $3\frac{1}{2}$  ft. per sec., of which the theoretical head is 0.19 ft.,  $Q = 5$  sq. ft.  $\times$  210 = 1050 cu. ft. per minute;  $H.P. = 1050 \times 0.19 \times 0.00189 = 0.377$  H.P.

The wheels would realize only about 0.4 of this power, on account of friction and slip, or 0.151 H.P., or about 0.03 H.P. per square foot of float, which is equivalent to 33 sq. ft. of float per H.P.

**Current Motors.** — A current motor could only utilize the whole power of a running stream if it could take all the velocity out of the water, so that it would leave the floats or buckets with no velocity at all; or in other words, it would require the backing up of the whole volume of the stream until the actual head was equivalent to the theoretical head due to the velocity of the stream. As but a small fraction of the velocity of the stream can be taken up by a current motor, its efficiency is very small. Current motors may be used to obtain small amounts of power from large streams, but for large powers they are not practicable.

**Bernouilli's Theorem.** — **Energy of Water Flowing in a Tube.** — The head due to the velocity is  $\frac{v^2}{2g}$ ; the head due to the pressure is  $\frac{f}{w}$ ; the head due to actual height above the datum plane is  $h$  feet. The total head is the sum of these =  $\frac{v^2}{2g} + h + \frac{f}{w}$ , in feet, in which  $v$  = velocity in feet per second,  $f$  = pressure in lbs. per sq. ft.,  $w$  = weight of 1 cu. ft. of water =

62.36 lbs. If  $p$  = pressure in lbs. per sq. in.,  $\frac{f}{w} = 2.309 p$ . If a constant quantity of water is flowing through a tube in a given time, the velocity varying at different points on account of changes in the diameter, the energy remains constant (loss by friction excepted) and the sum of the three heads is constant, the pressure head increasing as the velocity decreases, and *vice-versa*. This principle is known as "Bernouilli's Theorem."

In hydraulic transmission the velocity and the height above datum are usually small compared with the pressure-head. The work or energy of a given quantity of water under pressure = its volume in cubic feet  $\times$  its pressure in lbs. per sq. ft.; or if  $Q$  = quantity in cubic feet per second, and  $p$  = pressure in lbs. per square inch,  $W = 144 pQ$ , and the H.P. =  $\frac{144 pQ}{550} = 0.2618 pQ$ .

**Maximum Efficiency of a Long Conduit.** — A. L. Adams and R. C. Gemmell (*Eng'g News*, May 4, 1893) show by mathematical analysis that the conditions for securing the maximum amount of power through a long conduit of fixed diameter, without regard to the economy of water, is that the draught from the pipe should be such that the frictional loss in the pipe will be equal to one-third of the entire static head.

**Mill-Power.** — A "mill-power" is a unit used to rate a water-power for the purpose of renting it. The value of the unit is different in different localities. The following are examples (from Emerson):

*Holyoke, Mass.* — Each mill-power at the respective falls is declared to be the right during 16 hours in a day to draw 38 cu. ft. of water per second at the upper fall when the head there is 20 feet, or a quantity proportionate to the height at the falls. This is equal to 86.2 horse-power as a maximum.

*Lowell, Mass.* — The right to draw during 15 hours in the day so much water as shall give a power equal to 25 cu. ft. a second at the great fall, when the fall there is 30 feet. Equal to 85 H.P. maximum.

*Lawrence, Mass.* — The right to draw during 16 hours in a day so much water as shall give a power equal to 30 cu. ft. per second when the head is 25 feet. Equal to 85 H.P. maximum.

*Minneapolis, Minn.* — 30 cu. ft. of water per second with head of 22 feet. Equal to 74.8 H.P.

*Manchester, N.H.* — Divide 725 by the number of feet of fall minus 1, and the quotient will be the number of cubic feet per second in that fall. For 20 feet fall this equals 38.1 cu. ft., equal to 86.4 H.P. maximum.

*Cohoes, N.Y.* — "Mill-power" equivalent to the power given by 6 cu. ft. per second, when the fall is 20 feet. Equal to 13.6 H.P., maximum.

*Passaic, N.J.* — Mill-power: The right to draw 8½ cu. ft. of water per sec., fall of 22 feet, equal to 21.2 horse-power. Maximum rental \$700 per year for each mill-power = \$33.00 per H.P.

The horse-power maximum above given is that due theoretically to the weight of water and the height of the fall, assuming the water-wheel to have perfect efficiency. It should be multiplied by the efficiency of the wheel, say 75% for good turbines, to obtain the H.P. delivered by the wheel.

**Value of a Water-power.** — In estimating the value of a water-power, especially where such value is used as testimony for a plaintiff whose water-power has been diminished or confiscated, it is a common custom for the person making such estimate to say that the value is represented by a sum of money which, when put at interest, would maintain a steam-plant of the same power in the same place.

Mr. Charles T. Main (*Trans. A. S. M. E.*, xiii. 140) points out that this system of estimating is erroneous; that the value of a power depends upon a great number of conditions, such as location, quantity of water, fall or head, uniformity of flow, conditions which fix the expense of dams, canals, foundations of buildings, freight charges for fuel, raw materials and finished product, etc. He gives an estimate of relative cost of steam and water-power for a 500 H.P. plant from which the following is condensed:

The amount of heat required per H.P. varies with different kinds of business, but in an average plain cotton-mill, the steam required for heating and slashing is equivalent to about 25% of steam exhausted from the high-pressure cylinder of a compound engine of the power required to run that mill, the steam to be taken from the receiver.



The coal consumption per H.P. per hour for a compound engine is taken at  $1\frac{3}{4}$  lbs. per hour, when no steam is taken from the receiver for heating purposes. The gross consumption when 25% is taken from the receiver is about 2.06 lbs.

75% of the steam is used as in a compound engine at 1.75 lbs. = 1.31 lbs.  
 25% of the steam is used as in a high-pressure engine at 3.00 lbs. = .75 lb.

2.06 lbs.

The running expenses per H. P. per year are as follows:  
 2.06 lbs. coal per hour = 21.115 lbs. for  $10\frac{1}{4}$  hours or one day =  
 6503.42 lbs. for 308 days, which, at \$3.00 per long ton = \$8.71  
 Attendance of boilers, one man @ \$2.00, and one man @ \$1.25 = 2.00  
 Attendance of engine, one man @ \$3.50. 2.16  
 Oil, waste, and supplies. .80

The cost of such a steam-plant in New England and vicinity of 500 H. P. is about \$65 per H. P. Taking the fixed expenses as 4% on engine, 5% on boilers, and 2% on other portions, repairs at 2%, interest at 5%, taxes at  $1\frac{1}{2}$ % on  $\frac{3}{4}$  cost, and insurance at  $\frac{1}{2}$ % on exposed portion, the total average per cent is about  $12\frac{1}{2}$ %, or  $\$65 \times 0.12\frac{1}{2} =$  8.13

Gross cost of power and low-pressure steam per H. P. \$21.80

Comparing this with water-power, Mr. Main says: "At Lawrence the cost of dam and canals was about \$650,000, or \$65 per H. P. The cost per H. P. of wheel-plant from canal to river is about \$45 per H. P. of plant, or about \$65 per H. P. used, the additional \$20 being caused by making the plant large enough to compensate for fluctuation of power due to rise and fall of river. The total cost per H. P. of developed plant is then about \$130 per H. P. Placing the depreciation on the whole plant at 2%, repairs at 1%, interest at 5%, taxes and insurance at 1%, or a total of 9%, gives:

Fixed expenses per H. P. $\$1.30 \times .09 =$	\$11.70
Running expenses per H. P. (Estimated)	2.00
	\$13.70

"To this has to be added the amount of steam required for heating purposes, said to be about 25% of the total amount used, but in winter months the consumption is at least  $37\frac{1}{2}$ %. It is therefore necessary to have a boiler plant of about  $37\frac{1}{2}$ % of the size of the one considered with the steam-plant, costing about  $\$20 \times 0.375 = \$7.50$  per H. P. of total power used. The expense of running this boiler-plant is, per H. P. of the total plant per year:

Fixed expenses $12\frac{1}{2}$ % on \$7.50.....	\$0.94
Coal.....	3.26
Labor.....	1.23
	\$5.43

Making a total cost per year for water-power with the auxiliary boiler plant  $\$13.70 + \$5.43 = \$19.13$  which deducted from \$21.80 makes a difference in favor of water-power of \$2.67, or for 10,000 H. P. a saving of \$26,700 per year.

"It is fair to say," says Mr. Main, "that the value of this constant power is a sum of money which when put at interest will produce the saving; or if 6% is a fair interest to receive on money thus invested the value would be  $\$26,700 \div 0.06 = \$445,000$ ."

Mr. Main makes the following general statements as to the value of a water-power: "The value of an undeveloped variable power is usually nothing if its variation is great, unless it is to be supplemented by a steam-plant. It is of value then only when the cost per horse-power for the double-plant is less than the cost of steam-power under the same conditions as mentioned for a permanent power, and its value can be represented in the same manner as the value of a permanent power has been represented,

"The value of a developed power is as follows: If the power can be run cheaper than steam, the value is that of the power, plus the cost of plant, less depreciation. If it cannot be run as cheaply as steam, considering its cost, etc., the value of the power itself is nothing, but the value of the plant is such as could be paid for it new, which would bring the total cost of running down to the cost of steam-power, less depreciation."

Mr. Samuel Webber, *Iron Age*, Feb. and March, 1893, writes a series of articles showing the development of American turbine wheels, and incidentally criticises the statements of Mr. Main and others who have made comparisons of costs of steam and of water-power unfavorable to the latter. He says: "They have based their calculations on the cost of steam, on large compound engines of 1000 or more H. P. and 120 pounds pressure of steam in their boilers, and by careful 10-hour trials succeeded in figuring down steam to a cost of about \$20 per H. P., ignoring the well-known fact that its average cost in practical use, except near the coal mines, is from \$40 to \$50. In many instances dams, canals, and modern turbines can be all completed for a cost of \$100 per H. P.; and the interest on that, and the cost of attendance and oil, will bring water-power up to about \$10 or \$12 per annum; and with a man competent to attend the dynamo in attendance, it can probably be safely estimated at not over \$15 per H. P."

### WATER-WHEELS.

Water-wheels are classified as vertical wheels (including current motors, undershot, breast, and overshot wheels), turbine wheels, and impulse wheels. Undershot and breast wheels give very low efficiency, and are now no longer built. The overshot wheel when made of large diameter (wheels as high as 72 ft. diameter have been made) and properly designed have given efficiencies of over 80%, but they have been almost entirely supplanted by turbines, on account of their cumbersomeness, high cost, leakage, and inability to work in back water.

Turbines are generally classified according to the direction in which the water flows through them, as follows:

Tangential flow: Barker's mill. Parallel flow: Jonval. Radial outward flow: Fourneyron. Radial inward flow: Thompson vortex; Francis. Inward and downward flow: Central discharge scroll wheels and earlier American type of wheels; Swain turbine. Inward, downward, and outward flow: The American type of turbine.

### TURBINE WHEELS.

**Proportions of Turbines.** — Prof. De Volson Wood discusses at length the theory of turbines in his paper on Hydraulic Reaction Motors, *Trans. A. S. M. E.* xiv. 266. His principal deductions which have an immediate bearing upon practice are condensed in the following:

#### Notation.

$Q$  = volume of water passing through the wheel per second;  
 $h_1$  = head in the supply chamber above the entrance to the buckets,  
 $h_2$  = head in the tail-race above the exit from the buckets,  
 $z_1$  = fall in passing through the buckets,  
 $H = h_1 + z_1 - h_2$ , the effective head,  
 $\mu_1$  = coefficient of resistance along the guides,  
 $\mu_2$  = coefficient of resistance along the buckets,  
 $r_1$  = radius of the initial rim,  
 $r_2$  = radius of the terminal rim,  
 $V$  = velocity of the water issuing from supply chamber,  
 $v_1$  = initial velocity of the water in the bucket in reference to the bucket,  
 $v_2$  = terminal velocity in the bucket,  
 $\omega$  = angular velocity of the wheel,  
 $a$  = terminal angle between the guide and initial rim =  $CAB$ , Fig. 151,  
 $\gamma_1$  = angle between the initial element of bucket and initial rim =  $EAD$ ,  
 $\gamma_2 = GFI$ , the angle between the terminal rim and terminal element of the bucket,  
 $a = eb$ , Fig. 152 = the arc subtending one gate opening,

$a_1$  = the arc subtending one bucket at entrance. (In practice  $a_1$  is larger than  $a$ .)  
 $a_2 = gh$ , the arc subtending one bucket at exit,  
 $K = bf$ , normal section of passage, it being assumed that the passages and buckets are very narrow.  
 $k_1 = bd$ , initial normal section of bucket,  
 $k_2 = gi$ , terminal normal section,  
 $\omega r_1$  = velocity of initial rim,  
 $\omega r_2$  = velocity of terminal rim,  
 $\theta = HFI$ , angle between the terminal rim and actual direction of the water at exit,  
 $Y$  = depth of  $K$ ,  $\gamma_1$  of  $a_1$ , and  $\gamma_2$  of  $K_2$ , then  
 $K = Y a \sin \alpha$ ;  $K_1 = \gamma_1 a_1 \sin \gamma_1$ ;  $K_2 = \gamma_2 a_2 \sin \gamma_2$ .

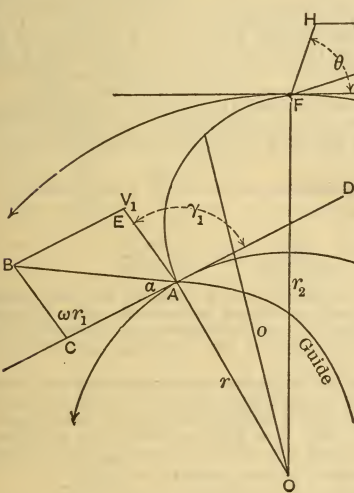

FIG. 151.

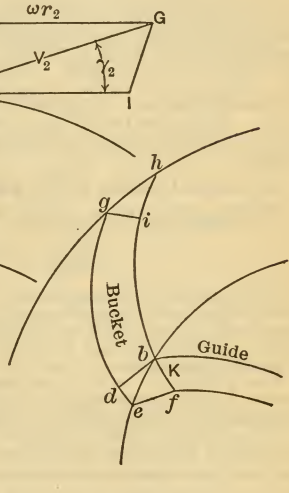

FIG. 152.

Three simple systems are recognized,  $r_1 < r_2$ , called outward flow;  $r_1 > r_2$ , called inward flow;  $r_1 = r_2$ , called parallel flow. The first and second may be combined with the third, making a mixed system.

*Value of  $\gamma_2$  (the quitting angle).* — The efficiency is increased as  $\gamma_2$  decreases, and is greatest for  $\gamma_2 = 0$ . Hence, theoretically, the terminal element of the bucket should be tangent to the quitting rim for best efficiency. This, however, for the discharge of a finite quantity of water, would require an infinite depth of bucket. In practice, therefore, this angle must have a finite value. The larger the diameter of the terminal rim the smaller may be this angle for a given depth of wheel and given quantity of water discharged. In practice  $\gamma_2$  is from  $10^\circ$  to  $20^\circ$ .

In a wheel in which all the elements except  $\gamma_2$  are fixed, the velocity of the wheel for best effect must increase as the quitting angle of the bucket decreases.

*Values of  $\alpha + \gamma_1$*  must be less than  $180^\circ$ , but the best relation cannot be determined by analysis. However, since the water should be deflected from its course as much as possible from its entering to its leaving the wheel, the angle  $\alpha$  for this reason should be as small as practicable.

In practice,  $\alpha$  cannot be zero, and is made from  $20^\circ$  to  $30^\circ$ .

The value  $r_1 = 1.4 r_2$  makes the width of the crown for internal flow about the same as for  $r_1 = r_2 \sqrt{1/2}$  for outward flow, being approximately 0.3 of the external radius.



*Values of  $\mu_1$  and  $\mu_2$ .* — The frictional resistances depend upon the construction of the wheel as to smoothness of the surfaces, sharpness of the angles, regularity of the curved parts, and also upon the speed it is run. These values cannot be definitely assigned beforehand, but Weisbach gives for good conditions  $\mu_1 = \mu_2 = 0.05$  to  $0.10$ .

They are not necessarily equal, and  $\mu_1$  may be from  $0.05$  to  $0.075$ , and  $\mu_2$  from  $0.06$  to  $0.10$  or even larger.

*Values of  $\gamma_1$*  must be less than  $180^\circ - \alpha$ .

To be on the safe side,  $\gamma_1$  may be  $20$  or  $30$  degrees less than  $180^\circ - 2\alpha$ , giving

$$\gamma_1 = 180^\circ - 2\alpha - 25 \text{ (say)} = 155^\circ - 2\alpha.$$

Then if  $\alpha = 30^\circ$ ,  $\gamma_1 = 95^\circ$ . Some designers make  $\gamma_1 90^\circ$ ; others more, and still others less, than that amount. Weisbach suggests that it be less, so that the bucket will be shorter and friction less. This reasoning appears to be correct for the inflow wheel, but not for the outflow wheel. In the Tremont turbines, described in the Lowell Hydraulic Experiments, this angle is  $90^\circ$ , the angle  $\alpha 20^\circ$ , and  $\gamma_2 10^\circ$ , which proportions insured a positive pressure in the wheel. Fourneyron made  $\gamma_1 = 90^\circ$ , and  $\alpha$  from  $30^\circ$  to  $33^\circ$  which values made the initial pressure in the wheel near zero.

*Form of Bucket.* — The form of the bucket cannot be determined analytically. From the initial and terminal directions and the volume of the water flowing through the wheel, the area of the normal sections may be found.

The normal section of the buckets will be:  $K = \frac{Q}{V}$ ;  $k_1 = \frac{Q}{v_1}$ ;  $k_2 = \frac{Q}{v_2}$ .

The depths of those sections will be:

$$Y = \frac{K}{a \sin \alpha}; \quad y_1 = \frac{k_1}{a_1 \sin \gamma_1}; \quad y_2 = \frac{k_2}{a_2 \sin \gamma_2}.$$

The changes of curvature and section must be gradual, and the general form regular, so that eddies and whirls shall not be formed. For the same reason the wheel must be run with the correct velocity to secure the best effect. In practice the buckets are made of two or three arcs of circles, mutually tangential.

*The Value of  $\omega$ .* — So far as analysis indicates, the wheel may run at any speed; but in order that the stream shall flow smoothly from the supply chamber into the bucket, the velocity  $V$  should be properly regulated.

If  $\mu_1 = \mu_2 = 0.10$ ,  $r_2 \div r_1 = 1.40$ ,  $\alpha = 25^\circ$ ,  $\gamma_1 = 90^\circ$ ,  $\gamma_2 = 12^\circ$ , the velocity of the initial rim for outward flow will be for maximum efficiency  $0.614$  of the velocity due to the head, or  $\omega r_1 = 0.614 \sqrt{2 gH}$ .

The velocity due to the head would be  $\sqrt{2 gH} = 1.414 \sqrt{gH}$ .

For an inflow wheel for the case in which  $r_1^2 = 2 r_2^2$ , and the other dimensions as given above,  $\omega r_1 = 0.682 \sqrt{2 gH}$ .

The highest efficiency of the Tremont turbine, found experimentally, was  $0.79375$ , and the corresponding velocity,  $0.62645$  of that due to the head, and for all velocities above and below this value the efficiency was less.

In the Tremont wheel  $\alpha = 20^\circ$  instead of  $25^\circ$ , and  $\gamma_2 = 10^\circ$  instead of  $12^\circ$ . These would make the theoretical efficiency and velocity of the wheel somewhat greater. Experiment showed that the velocity might be considerably larger or smaller than this amount without much diminution of the efficiency.

It was found that if the velocity of the initial (or interior) rim was not less than  $44\%$  nor more than  $75\%$  of that due to the fall, the efficiency was  $75\%$  or more. This wheel was allowed to run freely without any brake except its own friction, and the velocity of the initial rim was observed to be  $1.335 \sqrt{2 gH}$ , half of which is  $0.6675 \sqrt{2 gH}$ , which is not far from the velocity giving maximum effect; that is to say, when the gate is fully raised the coefficient of effect is a maximum when the wheel is moving with about half its maximum velocity.

*Number of Buckets.* — Successful wheels have been made in which the distance between the buckets was as small as  $0.75$  of an inch, and others as much as  $2.75$  inches. Turbines at the Centennial Exposition had buckets from  $4\frac{1}{2}$  inches to  $9$  inches from center to center. If too large they will not work properly. Neither should they be too deep. Horizontal parti-

tions are sometimes introduced. These secure more efficient working in case the gates are only partly opened. The form and number of buckets for commercial purposes are chiefly the result of experience.

*Ratio of Radii.* — Theory does not limit the dimensions of the wheel. In practice,

for outward flow,  $r_2 \div r_1$  is from 1.25 to 1.50;  
for inward flow,  $r_2 \div r_1$  is from 0.66 to 0.80.

It appears that the inflow-wheel has a higher efficiency than the outward-flow wheel. The inflow-wheel also runs somewhat slower for best effect. The centrifugal force in the outward-flow wheel tends to force the water outward faster than it would otherwise flow; while in the inward-flow wheel it has the contrary effect, acting as it does in opposition to the velocity in the buckets.

It also appears that the efficiency of the outward-flow wheel increases slightly as the width of the crown is less and the velocity for maximum efficiency is slower; while for the inflow-wheel the efficiency slightly increases for increased width of crown, and the velocity of the outer rim at the same time also increases.

*Efficiency.* — The exact value or the efficiency for a particular wheel must be found by experiment.

It seems hardly possible for the effective efficiency to equal, much less exceed, 86%, and all claims of 90 or more per cent for these motors should be discarded as improbable. A turbine yielding from 75% to 80% is extremely good. Experiments with higher efficiencies have been reported.

The celebrated Tremont turbine gave 79 $\frac{1}{4}$ % without the "diffuser," which might have added some 2%. A Jonval turbine (parallel flow) was reported as yielding 0.75 to 0.90, but Morin suggested corrections reducing it to 0.63 to 0.71. Weisbach gives the results of many experiments, in which the efficiency ranged from 50% to 84%. Numerous experiments give  $E = 0.60$  to 0.65. The efficiency, considering only the energy imparted to the wheel, will exceed by several per cent the efficiency of the wheel, for the latter will include the friction of the support and leakage at the joint between the sluice and wheel, which are not included in the former; also as a plant the resistances and losses in the supply-chamber are to be still further deducted.

*The Crowns.* — The crowns may be plane annular disks, or conical, or curved. If the partitions forming the buckets be so thin that they may be discarded, the law of radial flow will be determined by the form of the crowns. If the crowns be plane, the radial flow (or radial component) will diminish, for the outward-flow wheel, as the distance from the axis increases — the buckets being full — for the angular space will be greater.

Prof. Wood deduces from the formulæ in his paper the tables on the next page.

It appears from these tables: 1. That the terminal angle,  $\alpha$ , has frequently been made too large in practice for the best efficiency.

2. That the terminal angle,  $\alpha$ , of the guide should be for the inflow less than 10° for the wheels here considered, but when the initial angle of the bucket is 90°, and the terminal angle of the guide is 5° 28', the gain of efficiency is not 2% greater than when the latter is 25°.

3. That the initial angle of the bucket should exceed 90° for best effect for out flow-wheels.

4. That with the initial angle between 60° and 120° for best effect on inflow wheels the efficiency varies scarcely 1%.

5. In the outflow-wheel, column (9) shows that for the outflow for best effect the direction of the quitting water in reference to the earth should be nearly radial (from 76° to 97°), but for the inflow wheel the water is thrown forward in quitting. This shows that the velocity of the rim should somewhat exceed the relative final velocity backward in the bucket, as shown in columns (4) and (5).

6. In these tables the velocities given are in terms of  $\sqrt{2gh}$ , and the coefficients of this expression will be the part of the head which would produce that velocity if the water issued freely. There is only one case, column (5), where the coefficient exceeds unity, and the excess is so small it may be discarded; and it may be said that in a properly proportioned turbine with the conditions here given none of the velocities will equal that due to the head in the supply-chamber when running at best effect.

## Outward-flow Turbine.

$r_1 = r_2 \sqrt{1/2}$	$\mu_1 = \mu_2 = 0.10$	$\gamma_2 = 12^\circ$	Parallel Crowns.				$k_1 v_1 = k_2 v_2 = KV = Q = 1$ .			
Initial Angle. $\gamma_1$	Efficiency. $E$	Velocity Outer Rim. $r_2 \omega'$	Velocity Inner Rim. $r_1 \omega' = \sqrt{1/2} r_2 \omega'$	Relative Velocity of Exit. $v_2$	Relative Velocity of Entrance. $v_1$	Velocity of Exit from Supply-Chamber. $V$	Terminal Angle of Guide. $\alpha$	Direction of quitting Water. $\theta$	Head Equivalent of Energy in quitting Water. $\frac{w^2}{2g}$	$k_2 \sqrt{gH}$ .
1	2	3	4	5	6	7	8	9	10	11
60°	0.804	$0.972 \sqrt{2gH}$	$0.687 \sqrt{2gH}$	$1.048 \sqrt{2gH}$	$0.356 \sqrt{2gH}$	$0.595 \sqrt{2gH}$	31°	76°	0.051 H	0.67
90°	0.828	$0.874 \sqrt{2gH}$	$0.619 \sqrt{2gH}$	$0.931 \sqrt{2gH}$	$0.274 \sqrt{2gH}$	$0.676 \sqrt{2gH}$	23°	79°	0.039 H	0.76
120°	0.839	$0.798 \sqrt{2gH}$	$0.565 \sqrt{2gH}$	$0.843 \sqrt{2gH}$	$0.286 \sqrt{2gH}$	$0.749 \sqrt{2gH}$	19°	82°	0.031 H	0.84
150°	0.921	$0.709 \sqrt{2gH}$	$0.501 \sqrt{2gH}$	$0.707 \sqrt{2gH}$	$0.416 \sqrt{2gH}$	$0.886 \sqrt{2gH}$	13°	97°	0.022 H	1.00

## Inward-flow Turbine.

$r_1 = \sqrt{2} r_2$	$\mu_1 = \mu_2 = 0.10$	$\gamma_2 = 12^\circ$	Parallel Crowns.				$k_1 v_1 = k_2 v_2 = KV = Q = 1$ .			
$\gamma_1$	$E$	Velocity Outer Rim. $r_1 \omega'$	Velocity Inner Rim. $r_2 \omega'$	$v_2$	$v_1$	$V$	$\alpha$	$\theta$	$\frac{w^2}{2g}$	$k_2 \sqrt{gH}$ .
60°	0.920	$0.709 \sqrt{2gH}$	$0.501 \sqrt{2gH}$	$0.476 \sqrt{2gH}$	$0.089 \sqrt{2gH}$	$0.672 \sqrt{2gH}$	7°	110°	0.010 H	1.48
90°	0.920	$0.688 \sqrt{2gH}$	$0.487 \sqrt{2gH}$	$0.470 \sqrt{2gH}$	$0.069 \sqrt{2gH}$	$0.691 \sqrt{2gH}$	5°	106°	0.010 H	1.50
120°	0.919	$0.668 \sqrt{2gH}$	$0.473 \sqrt{2gH}$	$0.456 \sqrt{2gH}$	$0.077 \sqrt{2gH}$	$0.709 \sqrt{2gH}$	4°	105°	0.010 H	1.55
150°	0.918	$0.634 \sqrt{2gH}$	$0.448 \sqrt{2gH}$	$0.429 \sqrt{2gH}$	$0.126 \sqrt{2gH}$	$0.743 \sqrt{2gH}$	3°	107°	0.009 H	1.65



7. The inflow turbine presents the best conditions for construction for producing a given effect, the only apparent disadvantage being an increased first cost due to an increased depth, or an increased diameter for producing a given amount of work. The larger efficiency should, however, more than neutralize the increased first cost.

**Tests of Turbines.** — Emerson says that in testing turbines it is a rare thing to find two of the same size which can be made to do their best at the same speed. The best speed of one of the leading wheels is invariably wide from the tabled rate. It was found that a 54-in. Leffel wheel under 12 ft. head gave much better results at 78 revolutions per minute than at 90.

Overshot wheels have been known to give 75% efficiency, but the average performance is not over 60%.

A fair average for a good turbine wheel may be taken at 75%. In tests of 18 wheels made at the Philadelphia Water-works in 1859 and 1860, one wheel gave less than 50% efficiency, two between 50% and 60%, six between 60% and 70%, seven between 71% and 77%, two 82%, and one 87.77%. (Emerson.)

**Tests of Turbine Wheels at the Centennial Exhibition, 1876.** (From a paper by R. H. Thurston on The Systematic Testing of Turbine Wheels in the United States, *Trans. A. S. M. E.*, viii. 359.) — In 1876 the judges at the International Exhibition conducted a series of trials of turbines. Many of the wheels offered for tests were found to be more or less defective in fitting and workmanship. The following is a statement of the results of all turbines entered which gave an efficiency of over 75%. Seven other wheels were tested, giving results between 65% and 75%.

Maker's Name, or Name the Wheel is Known by.	Per Cent at Full Gate or Discharge.	Per Cent at about 9/10 of Full Discharge.	Per Cent at about 7/8 of Full Discharge.	Per Cent at about 3/4 of Full Discharge.	Per Cent at about 5/8 of Full Discharge.	Per Cent at about 1/2 of Full Discharge.	Per Cent at about 4/10 of Full Discharge.
Risdon.....	87.68	.....	86.20	82.41	.....	75.35	.....
National.....	83.79	.....	.....	70.79	.....	.....	.....
Geyelin (single).....	83.30	.....	.....	.....	.....	.....	.....
Thos. Tait.....	82.13	.....	.....	70.40	66.35	.....	55.00
Goldie & McCullough.....	81.21	.....	71.01	55.90	.....	.....	.....
Rodney Hunt Mach. Co.....	78.70	71.66	.....	68.60	51.03	.....	.....
Tyler Wheel.....	79.59	.....	81.24	79.92	67.23	69.59	.....
Geyelin (duplex).....	77.57	.....	.....	.....	.....	.....	.....
Knowlton & Dolan.....	77.43	74.25	.....	.....	62.75	.....	.....
E. T. Cope & Sons.....	76.94	.....	69.92	.....	.....	.....	.....
Barber & Harris.....	76.16	73.33	.....	.....	70.87	71.74	.....
York Manufacturing Co.....	75.70	.....	67.08	67.57	62.06	.....	.....
W. F. Mosser & Co.....	75.15	74.89	71.90	70.52	.....	66.04	.....

The limits of error of the tests, says Prof. Thurston, were very uncertain; they are undoubtedly considerable as compared with the later work done in the permanent flume at Holyoke — possibly as much as 4% or 5%.

Experiments with "draught-tubes," or "suction-tubes," which were actually "diffusers" in their effect, so far as Prof. Thurston has analyzed them, indicate the loss by friction which should be anticipated in such cases, this loss decreasing as the tube increased in size, and increasing as its diameter approached that of the wheel — the minimum diameter tried. It was sometimes found very difficult to free the tube from air completely, and next to impossible, during the interval, to control the speed with the brake. Several trials were often necessary before the power due to the full head could be obtained. The loss of power by gearing and by belting was variable with the proportions and arrangement of the gears and pulleys, length of belt, etc., but averaged not far from 30% for a single pair of bevel-

gears, uncut and dry, but smooth for such gearing, and but 10% for the same gears, well lubricated, after they had been a short time in operation. The amount of power transmitted was, however, small, and these figures are probably much higher than those representing ordinary practice. Introducing a second pair — spur-gears — the best figures were but little changed, although the difference between the case in which the larger gear was the driver, and the case in which the small wheel was the driver, was perceivable, and was in favor of the former arrangement. A single straight belt gave a loss of but 2% or 3%, a crossed belt 6% to 8%, when transmitting 14 horse-power with maximum tightness and transmitting power. A "quarter turn" wasted about 10% as a maximum, and a "quarter twist" about 5%.

**Dimensions of Turbines.** — For dimensions, power, etc., of standard makes of turbines consult the catalogues of different manufacturers. The wheels of different makers vary greatly in their proportions for any given capacity.

**Rating and Efficiency of Turbines.** — The following notes and tables are condensed from a pamphlet entitled "Turbine Water-wheel Tests and Power Tables," by R. E. Horton. Water-supply and Irrigation Paper No. 180, U. S. Geol. Survey, 1906.

Theory does not indicate the numbers of guides or buckets most desirable. If, however, they are too few, the stream will not properly follow the flow lines indicated by theory. If the buckets are too small and too numerous, the surface-friction factor will be large.

It is customary to make the number of guide chutes greater than the number of buckets, so that any object passing through the chutes will be likely to pass through the buckets also.

With most forms of gates the size of the jet is decreased as the gate is closed, the bucket area remaining unchanged, so that the wheel operates mostly by reaction at full gate and by impulse to an increasing extent as the gate is closed. Hence, the speed of maximum efficiency varies as the gate is closed. The ratio peripheral velocity ÷ velocity due head for maximum efficiency for a 36-inch Hercules turbine is given below:

Proportional gate opening . . . Full	0.806	0.647	0.489	0.379
Maximum efficiency . . . . . 85.6	87.1	86.3	80	73.1
Periph. vel. ÷ vel. due head. . . 0.677	0.648	0.641	0.603	0.585

American turbine practice differs from European practice in that water wheels are placed on the market in standard or stock sizes, whereas in Europe, notably on the Continent, each turbine is designed for the special conditions under which it is to operate, the designs being based on mathematical theory and following chiefly the Jonval and Fourneyron types.

Having been developed by experiment after successive Holyoke tests, American stock pattern turbines probably give their best efficiencies at about the head under which those tests are made—*i. e.*, 14 to 17 ft. The shafts, runners, and cases are so constructed as to enable stock sizes of wheels to be used under heads ranging from 6 to 60 ft. For very low heads they are perhaps unnecessarily cumbersome. For heads exceeding 60 ft. American builders commonly resort to the use of bronze buckets and "special wheels," not designed along theoretical lines, as in Europe, but representing modifications of the standard patterns.

The double Fourneyron turbine used in the first installation of the Niagara Falls Power Co. is operated under a head of about 135 ft. Two wheels are used, one being placed at the top and the other at the bottom of the globe penstock. The runner and buckets are attached to the vertical shaft. Holes are provided in the upper penstock drum to allow water under full pressure of the head to pass through and act vertically against the upper runner. In this way the vertical pressure of the great column of water is neutralized and a means is provided to counterbalance the weight of the long vertical shaft and the armature of the dynamo at its upper end. These turbines discharge 430 cu. ft. per second, make 250 rev. per min., and are rated at 5000 H.P.

A Fourneyron turbine at Trenton Falls, N. Y., operates under 265 ft. gross head and has 37 buckets, each 5½ in. deep and ¼ inch wide at the least section. The total area of outflow at the minimum section is 165 sq. in. The wheel develops 950 H.P.

The theoretical horse-power of a given quantity of water  $Q$ , in cu. ft. per min., falling through a height  $H$ , in ft., is  $H.P. = 0.00189 QH$ .

In practice the theoretical power is multiplied by an efficiency factor  $E$  to obtain the net power available on the turbine shaft as determinable by dynamometrical test.

Manufacturers' rating tables are usually based on efficiencies of about 80%. In selecting turbines from a maker's list the rated efficiency may be obtained by the following formula:

$E$  = tabled efficiency. H.P. = tabled horse-power, and  $Q$  = tabled discharge (C.F.M.) for any head  $H$ .  $E = \frac{33,000 \times \text{H.P.}}{62.4 \times Q \times H} = 528.8 \frac{\text{H.P.}}{Q \times H}$ .

*Relations of Power, Speed and Discharge.*—Nearly all American turbine builders publish rating tables showing the discharge in cu. ft. per min., rev. per min., and H.P. for each size pattern under heads varying from 3 or 4 ft. to 40 ft. or more.

Examples of each size of a number of the leading types of turbines have been tested in the Holyoke flume. For such turbines the rating tables have usually been prepared directly from the tests.

Let  $M$ ,  $R$ , and  $Q$  denote, respectively, the H.P., r.p.m., and discharge in cu. ft. per min. of a turbine, as expressed in the tables, for any head  $H$  in feet. The subscripts 1 and 16 added signify the power, speed, and discharge for the particular heads 1 and 16 ft., respectively.

Let  $P$ ,  $N$ , and  $F$  denote coefficients of power, speed, and discharge, which represent, respectively, the H.P., r.p.m., and discharge in cu. ft. per sec. under a head of 1 ft.

The speed of a turbine or the number of rev. per min. and the discharge are proportional to the square root of the head. The H.P. varies with the product of the head and discharge, and is consequently proportional to the three-halves power of the head.

Given the values of  $M$ ,  $R$ , and  $Q$  from the tables for any head  $H$ , these quantities for any other head  $h$  are:

$$M_H : M_h :: H^{3/2} : h^{3/2} ; R_H : R_h :: H^{1/2} : h^{1/2} ; Q_H : Q_h :: H^{1/2} : h^{1/2}.$$

If  $H$  and  $h$  are taken at 16 ft. and 1 ft., respectively, the values of the coefficients  $P$ ,  $N$ , and  $F$  are:

$$P = M_{16}/H^{3/2} = M_{16}/64 = 0.01562 M_{16}$$

$$N = R_{16}/H^{1/2} = R_{16}/4 = 0.25 R_{16}$$

$$F = Q_{16}/60 H^{1/2} = Q_{16}/240 = 0.00417 Q_{16}.$$

$P$ ,  $N$ , and  $F$ , when derived for a given wheel, enable the power, speed, and discharge to be calculated without the aid of the tables, and for any head  $H$ , by means of the following formulas:

$$M = M_1 H^{3/2} / H_1 = P H^{3/2}$$

$$R = R_1 \sqrt{H/H_1} = N \sqrt{H}$$

$$Q = Q_1 \sqrt{H/H_1} = 60 F \sqrt{H}.$$

Since at a head of 1 ft., and  $M_1$ ,  $R_1$ , and  $Q_1$  equal  $P$ ,  $N$ , and  $60 F$ , respectively,  $H_1^{3/2}$  and  $\sqrt{H_1}$  each equals 1. Calculations involving  $H^{3/2}$  may be facilitated by the use of the appended table of three-halves powers. Rating tables for sizes other than those tested are computed usually on the following basis:

1. The efficiency and coefficients of gate and bucket discharge for the sizes tested are assumed to apply to the other sizes also.
2. The discharge for additional sizes is computed in proportion to the measured area of the vent or discharge orifices.

Having these data, together with the efficiency, the tables of discharge and horse-power can be prepared. The peripheral speed corresponding to maximum efficiency determined from tests of one size of turbine may be assumed to apply to the other sizes also. From this datum the revolutions per minute can be computed, the number of revolutions required to give a constant peripheral speed being inversely proportional to the diameter of the turbine.

In point of discharge, the writer's observation has been that the rating tables are usually fairly accurate. In the matter of efficiency there are undoubtedly much larger discrepancies.



TABLE OF  $H^{3/2}$  FOR CALCULATING HORSE-POWER OF TURBINES.

Head Ft.	0.0	0.2	0.4	0.6	0.8	Head Ft.	0.0	0.2	0.4	0.6	0.8
0	0.00	0.09	0.25	0.46	0.72						
1	1.00	1.32	1.66	2.02	2.42	51	364.21	366.36	368.50	370.66	372.82
2	2.83	3.26	3.72	4.19	4.69	52	374.98	377.14	379.31	381.48	383.66
3	5.20	5.72	6.27	6.83	7.41	53	385.85	388.03	390.22	392.42	394.61
4	8.00	8.61	9.23	9.87	10.52	54	396.81	399.02	401.23	403.45	405.67
5	11.18	11.86	12.55	13.25	13.97	55	407.89	410.11	412.35	414.58	416.82
6	14.70	15.44	16.19	16.96	17.73	56	419.07	421.31	423.56	425.81	428.07
7	18.52	19.32	20.13	20.95	21.78	57	430.34	432.60	434.87	437.15	439.43
8	22.63	23.48	24.35	25.22	26.11	58	441.71	444.00	446.29	448.58	450.88
9	27.00	27.91	28.82	29.75	30.68	59	453.09	455.49	457.80	460.12	462.43
10	31.62	32.58	33.54	34.51	35.49	60	464.75	467.08	469.41	471.75	474.08
11	36.48	37.48	38.49	39.51	40.53	61	476.42	478.77	481.12	483.47	485.82
12	41.57	42.61	43.66	44.73	45.79	62	488.19	490.55	492.92	495.29	497.67
13	46.87	47.96	49.05	50.15	51.26	63	500.04	502.43	504.82	507.20	509.60
14	52.38	53.51	54.64	55.79	56.94	64	512.00	514.40	516.80	519.22	521.63
15	58.09	59.26	60.43	61.61	62.80	65	524.04	526.46	528.89	531.31	533.75
16	64.00	65.20	66.41	67.63	68.85	66	536.18	538.62	541.07	543.51	545.96
17	70.09	71.33	72.58	73.84	75.10	67	548.42	550.87	553.33	555.80	558.27
18	76.37	77.64	78.93	80.22	81.52	68	560.74	563.22	565.70	568.18	570.66
19	82.82	84.13	85.45	86.77	88.10	69	573.16	575.65	578.14	580.65	583.15
20	89.44	90.79	92.14	93.50	94.86	70	585.66	588.17	590.68	593.20	595.73
21	96.23	97.61	99.00	100.39	101.79	71	598.25	600.79	603.32	605.85	608.39
22	103.19	104.60	106.02	107.44	108.87	72	610.93	613.48	616.04	618.59	621.15
23	110.30	111.74	113.19	114.65	116.11	73	623.71	626.27	628.84	631.41	633.99
24	117.58	119.05	120.53	122.01	123.50	74	636.57	639.15	641.74	644.33	646.92
25	125.00	126.50	128.01	129.53	131.05	75	649.52	652.11	654.72	657.33	659.94
26	132.57	134.11	135.65	137.19	138.74	76	662.55	665.17	667.79	670.41	673.04
27	140.30	141.86	143.43	145.00	146.58	77	675.67	678.20	680.94	683.58	686.23
28	148.16	149.75	151.35	152.95	154.56	78	688.87	691.52	694.18	696.84	699.50
29	156.17	157.79	159.41	161.04	162.68	79	702.16	704.83	707.50	710.18	712.85
30	164.32	165.96	167.61	169.27	170.93	80	715.54	718.22	720.92	723.60	726.30
31	172.60	174.27	175.95	177.64	179.33	81	729.00	731.70	734.40	737.11	739.82
32	181.02	182.72	184.42	186.13	187.85	82	742.54	745.26	747.98	750.70	753.43
33	189.57	191.30	193.03	194.76	196.51	83	756.16	758.90	761.63	764.38	767.12
34	198.25	200.00	201.76	203.52	205.29	84	769.87	772.62	775.37	778.13	780.89
35	207.06	208.84	210.62	212.41	214.20	85	783.66	786.42	789.20	791.97	794.75
36	216.00	217.80	219.61	221.42	223.24	86	797.53	800.31	803.10	805.89	808.68
37	225.06	226.89	228.72	230.56	232.40	87	811.48	814.27	817.08	819.88	822.70
38	234.25	236.10	237.96	239.82	241.68	88	825.51	828.32	831.15	833.97	836.79
39	243.56	245.43	247.31	249.20	251.09	89	839.62	842.45	845.29	848.13	850.96
40	252.98	254.88	256.79	258.70	260.61	90	853.81	856.66	859.51	862.37	865.22
41	262.53	264.45	266.38	268.31	270.25	91	868.08	870.94	873.81	876.68	879.55
42	272.19	274.14	276.09	278.05	280.01	92	882.43	885.30	888.19	891.07	893.96
43	281.97	283.94	285.91	287.89	289.88	93	896.86	899.75	902.65	905.55	908.45
44	291.86	293.86	295.85	297.85	299.86	94	911.36	914.27	917.18	920.10	923.02
45	301.87	303.88	305.90	307.93	309.95	95	925.94	928.87	931.79	934.73	937.66
46	311.99	314.02	316.07	318.11	320.16	96	940.60	943.54	946.48	949.43	952.38
47	322.22	324.27	326.34	328.41	330.48	97	955.33	958.29	961.25	964.21	967.17
48	332.55	334.63	336.72	338.81	340.90	98	970.14	973.11	976.09	979.07	982.05
49	343.00	345.10	347.21	349.32	351.43	99	985.03	988.02	991.01	994.00	996.99
50	353.55	355.67	357.80	359.93	362.07	100	1000.00	.....	.....	.....	.....

### Rating Table for Turbines.

LEFFEL STANDARD (NEW TYPE). PIVOT GATE. [1900 list.]

Diameter of Runner in Inches.	Manufacturer's Rating for a Head of 16 Ft.			Coefficients.		
	H. P. (=M).	Cu. Ft. per min. (=Q).	Revs. per min. (=R).	Power (=P).	Dis- charge. (=F).	Speed (=N).
10.....	3.70	53	535	0.058	0.220	133.8
11 1/2.....	4.9	201	463	.076	.838	115.8
13 1/4.....	6.5	267	404	.101	1.113	101.0
15 1/4.....	8.4	348	351	.131	1.451	87.8
17 1/2.....	11.00	455	306	.172	1.897	76.5
20.....	14.9	602	268	.232	2.510	67
23.....	19.4	802	233	.303	3.344	58.2
26 1/2.....	25.25	1,043	202	.393	4.339	50.5
30 1/2.....	33.61	1,390	176	.524	5.796	44
35.....	44.3	1,831	153	.691	7.635	38.2
40.....	58.2	2,406	134	.908	10.033	33.5
44.....	67.75	2,800	122	1.058	11.676	30.5
48.....	84.1	3,475	110	1.312	14.490	27.5
56.....	142	5,858	96	2.215	24.428	24
61.....	168	6,950	87	2.621	28.982	21.8
66.....	202	8,340	80	3.151	34.778	20
74.....	247	10,222	72	3.853	42.623	18

LEFFEL IMPROVED SAMSON. PIVOT GATE. [1897 and 1900 lists.]

20.....	51.7	2,111	325	0.806	8.803	81.3
23.....	68.3	2,792	283	1.065	11.643	70.8
26.....	87.3	3,569	250	1.362	14.883	62.5
30.....	116	4,751	217	1.810	19.812	54.3
35.....	158	6,440	186	2.465	26.855	46.5
40.....	207	8,446	163	3.229	35.220	40.8
45.....	262	10,689	145	4.087	44.573	36.3
50.....	324	13,196	130	5.054	55.027	32.5
55.....	405	16,554	116	6.318	69.030	29.0
62.....	497	20,292	105	7.753	84.618	26.3
68.....	597	24,409	96	9.313	101.786	24.0
74.....	708	28,906	88	11.045	120.538	22.0

VICTOR HIGH PRESSURE TURBINE. CYLINDER GATE. [1903 list.]  
Ratings for 100 Ft. Head.

14.....	37	247	656	0.037	0.412	65.6
16.....	50	332	574	.050	.553	57.4
18.....	66	442	510	.066	.733	51.0
20.....	82	542	459	.082	.903	45.9
22.....	106	707	417	.106	1.178	41.7
24.....	128	850	383	.128	1.417	38.3
26.....	151	1,001	353	.151	1.668	35.3
28.....	173	1,147	328	.173	1.912	32.8
30.....	191	1,265	306	.191	2.108	30.6
33.....	228	1,512	278	.228	2.520	27.8
36.....	272	1,805	255	.272	3.008	25.5
39.....	303	2,005	235	.303	3.342	23.5
42.....	343	2,277	219	.343	3.795	21.9
45.....	387	2,563	204	.387	4.272	20.4
48.....	426	2,820	191	.426	4.700	19.1
51.....	462	3,063	180	.462	5.105	18.0
54.....	504	3,340	170	.504	5.567	17.0
57.....	544	3,605	161	.544	6.008	16.0
60.....	590	3,907	153	.590	6.512	15.3
63.....	619	4,100	146	.619	6.833	14.6
66.....	680	4,505	139	.680	7.508	13.9
69.....	742	4,910	133	.742	8.183	13.3
72.....	799	5,290	127	.799	8.817	12.7

The discharge of turbines is nearly always expressed in cubic feet per minute. The "vent" in square inches is also used by millwrights and manufacturers, although to a decreasing extent. The vent of a turbine is the area of an orifice which would, under any given head, theoretically discharge the same quantity of water that is vented or passed through a turbine under that same head when the wheel is so loaded as to be running at maximum efficiency.

If  $V$  = vent in sq. in.,  $Q$  = discharge in cu. ft. per min. under a head  $H$ ,  $F$  = discharge in cu. ft. per sec. under a head of 1 foot, then  $Q = 60 V/144 \sqrt{2gH} = 3.344 V\sqrt{H}$ , and  $V = 0.3Q/\sqrt{H}$ ; also  $V = 17.94 F$  and  $F = 0.0557 V$ .

The vent of a turbine should not be confused with the area of the outlet orifice of the buckets. The actual discharge through a turbine is commonly from 40 to 60% of the theoretical discharge of an orifice whose area equals the combined cross-sectional areas of the outlet ports measured in the narrowest section.

The high-pressure turbine is a recent design (1903), and is tabled for heads of 70 to 675 feet.

**A 10,000 H.P. Turbine at Snoqualmie, Wash.** (Arthur Giesler, *Eng. News*, Mar. 20, 1906.)—The fall is about 270 ft. high. The machinery is placed in an underground chamber excavated in the rock about 250 ft. below the surface, and 300 ft. up-stream from the crest of the falls. A tail-race tunnel runs to the lower reach of the river. The wheel was designed by the Platt Iron Works Co., Dayton, O., for an effective head of 260 ft. and 300 r.p.m., the latter being fixed by the limitations of dynamo design. There was no precedent for a generator approximating 10,000 H.P. running at such a speed. The turbine is a horizontal shaft machine, of the Francis type, radial inward flow with central axial discharge. The turbine proper has only one bearing,  $8\frac{3}{8} \times 26$  in., the generator having three bearings. The draft tube is on the generator (front) side. The shaft-bearing, thrust-bearing and thrust-balancing devices are at the back side. The wheel is 66 in. outside diam. by 9 in. wide through the vanes. It has 34 vanes which extend a short distance beyond the end plate of the wheel on the discharge side. There are 32 guide vanes, of the swivel type, connected to a rotatable ring which is actuated by a Lombard governor. The turbine wheel or runner is an annular steel casting. It is bolted to a disk 46-in. diam., which is an enlargement of the  $13\frac{1}{2}$  in. hollow nickel-steel shaft. A test for efficiency was made, in which the output was measured on the electrical side, and the input by the drop of head across the head gate. At 10,000 H.P. the efficiency shown was 84%, the figure being subject to the inaccuracy of the water measurement. The maximum capacity registered was 8250 K.W. or 11,000 H.P. With the generator and the governor disconnected, with full gates and no load, the wheel ran at 505 r.p.m.

**Turbines of 13,500 H.P.**—Four Francis turbines, with vertical shafts, rated at 13,500 H.P. each, have been built by Allis-Chalmers Co., for the Great Northern Power Co., Duluth, Minn. The available head is 365 ft., and the wheels run at 375 r.p.m.; discharging, at full load, about 400 cu. ft. per second, each. The runners are 62 in. diam. The penstock for each wheel is 84 in. diam., reduced gradually to 66 in. at the wheel. (Bulletin No. 1613, A.-C. Co.)

**The "Fall-increaser" for Turbines.**—A circular issued Nov., 1908, by Clemens Herschel, the inventor of the Venturi Meter, illustrates a device, based on the principle of the meter, for diminishing the back-water head which acts against the turbine. The surplus water, which would otherwise run to waste, is caused to flow into a tube of the Venturi shape, and the pressure in the narrow section, or throat of this tube, is less than that due to the head of the back-water into which the tube discharges. The throat is perforated with a great number of 6-in. holes, through which the discharge-water of the turbine is caused to flow, the velocity through the holes being never over 4 ft. per second. The circular says:

The fall-increaser is a form of power-house foundation construction so made that by running through it water, which would otherwise waste over the dam, the fall acting on the turbines is increased, and the output of power is kept at its maximum quantity, in spite of the back-water



which always accompanies an abundance of river flow passing down the river.

The results show that fall-increasers add about 10% to the annual output of power with no appreciable increase in operating expenses.

For half the days of the year the fall-increasers are shut down because there is not enough, or only enough, water to supply the plain turbines; but for the other half of the year the fall-increasers keep the output of power practically constant, and at the full output, where this power output would fall to half the full output or less if the fall-increasers had not been built.

An illustrated description of the fall-increaser, with results of tests, is given in the *Harvard Eng'g Journal*, June, 1908. See also U. S. Pat. No. 873,435 and *Eng. News*, June 11, 1908.

### TANGENTIAL OR IMPULSE WATER-WHEELS.

**The Pelton Water-wheel.** — Mr. Ross E. Browne (*Eng'g News*, Feb. 20, 1892) thus outlines the principles upon which this water-wheel is constructed:

The function of a water-wheel, operated by a jet of water escaping from a nozzle, is to convert the energy of the jet, due to its velocity, into useful work. In order to utilize this energy fully the wheel-bucket, after catching the jet, must bring it to rest before discharging it, without inducing turbulence or agitation of the particles.

This cannot be fully effected, and unavoidable difficulties necessitate the loss of a portion of the energy. The principal losses occur as follows: First, in sharp or angular diversion of the jet in entering, or in its course through the bucket, causing impact, or the conversion of a portion of the energy into heat instead of useful work. Second, in the so-called frictional resistance offered to the motion of the water by the wetted surfaces of the buckets, causing also the conversion of a portion of the energy into heat instead of useful work. Third, in the velocity of the water, as it leaves the bucket, representing energy which has not been converted into work.

Hence, in seeking a high efficiency: 1. The bucket-surface at the entrance will be approximately parallel to the relative course of the jet, and the bucket should be curved in such a manner as to avoid sharp angular deflection of the stream. If, for example, a jet strikes a surface at an angle and is sharply deflected, a portion of the water is backed, the smoothness of the stream is disturbed, and there results considerable loss by impact and otherwise.

2. The path of the jet in the bucket should be short; in other words, the total wetted surface of the bucket should be small, as the loss by friction will be proportional to this.

3. The discharge end of the bucket should be as nearly tangential to the wheel periphery as compatible with the clearance of the bucket which follows; and great differences of velocity in the parts of the escaping water should be avoided. In order to bring the water to rest at the discharge end of the bucket, it is shown, mathematically, that the velocity of the bucket should be one half the velocity of the jet.

A bucket, such as shown in Fig. 153, will cause the heaping of more or less dead or turbulent water at the point indicated by dark shading. This dead water is subsequently thrown from the wheel with considerable velocity, and represents a large loss of energy. The introduction of the wedge in the Pelton bucket (see Fig. 154) is an efficient means of avoiding this loss.



FIG. 153.



FIG. 154.

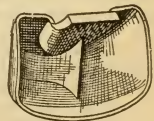

FIG. 155.

A wheel of the form of the Pelton (Fig. 155) conforms closely in construction to each of these requirements. [In wheels as now made (1909)

the sharp corners shown in this bucket are eliminated. See catalogues of the Pelton Water Wheel Co., Josbua Hendy Iron Works, and Abner Doble Co., all of San Francisco.]

**Considerations in the Choice of a Tangential Wheel** (Joshua Hendy Iron Works.) — The horse-power that can be developed by a tangential wheel does not depend upon the size of the wheel but *solely upon the head and volume of water available*. The number of revolutions per minute that a wheel makes (running under normal conditions) depends solely upon two factors, viz., its diameter and the head of water.

The choice of the diameter of a wheel is not therefore controlled by the power required but by the speed required when working under a given head. If a wheel has no load, and is not governed, it will speed up until the periphery is revolving at approximately the same velocity as the spouting velocity of the jet, but as soon as the wheel commences to develop power by driving machinery, etc., its velocity will drop. In a properly designed wheel the velocity of the rim in lineal feet per minute, at full load, will be from 48 to 50% of the spouting velocity of the jet.

The diameter of pulley wheels on wheel shaft and countershafts of machinery should be so proportioned that the water wheel shall run at the speed given in the table.

The width, area and curvature of buckets are designed to meet conditions of volume of flow under given heads. The higher the peripheral velocity of the wheel, the greater the volume of water that the buckets can handle, and consequently the same standard wheel can handle more water, the higher the head.

Standard wheels can generally be adapted one size larger or one size smaller to meet conditions of a variation of speed or volume of flow under a given head. Wheels designed for a given horse-power can be used for smaller powers (within reasonable limits) with very little loss of efficiency, but an increase in the volume to be used requires a larger bucket. If, for the purpose of maintaining the same speed conditions, the same diameter of wheel is to be adhered to, then a special wheel must be built with either very large buckets or with two or more nozzles, or else a double or multiple unit must be adopted.

It is advised to subdivide large streams between two, three or more runners, as this insures a greater freedom from breakdown and is often cheapest in the end. Single-nozzle, multiple runner units are easier to govern than multiple-nozzle, single runner units. When two or more nozzles are used in combination on one runner, the increased volume to be dealt with is divided between the different nozzles, which are so arranged that their respective jets impinge on different buckets at different parts of the periphery. Three-nozzle and five-nozzle wheels have many disadvantages, when governing is required, and should only be adopted for handling a very large volume of water when other designs cannot be used.

**Combined Heads.** — When two or more water powers are available at the same site, but under different heads, it is possible to utilize them by mounting wheels of different diameters in parallel, or, when the difference of head and volume is very great, it would even be possible to arrange for a turbine for the low head and a tangential wheel for the high head, although, in the latter case, it would probably be best to mount them independently and connect to the machinery through the medium of belts and countershafts. In either case, separate pipe lines must be employed.

**Reversible Wheels.** — In the case of reversible wheels desired for use with hoists, cableways, etc., two wheels of proper dimensions and the same type may be mounted parallel on the same shaft, one of the wheels having the buckets and nozzles arranged to run in the opposite direction to the other. Suitable valves, levers and pipe connections can be arranged to cut the water off one wheel and turn it on to the other.

**Horizontal Wheels.** — For electric generating stations, when it is desired to place the wheels below the floor of the generators, where vertical direct-connected equipments are used, tangential wheels may be mounted horizontally with vertical shafts and step bearings.

**Notes on Hydraulic Power Installations.** (Joshua Hendy Iron Works.) — Apertures of screens must be slightly smaller than the diameter of the smallest nozzle used.

When not in use, keep the pipe full by closing the valve at the lower end. There is less liability for trouble from expansion and contraction with a full pipe line.

Equip the pipe line with air valves, approximately one for every 20 ft. of head.

When operating under high heads, when no other precaution has been taken to avoid water ram during the process of governing, it is advisable to install relief valves between the lower end of the pipe line and the gates or controllers.

When operating under even moderately high heads, if no safety device or by-pass has been installed, and a plain valve is to be used, sliding gates and butterfly valves should not be employed, but only screw gates, as the former would be too rapid in their action and might set up a dangerous water ram.

The size of the nozzle that must be used on a wheel for maximum efficiency must be such as will just keep the pipe line full. If water overflows, put on a larger nozzle. If the pipe remains partly empty, put on a smaller nozzle, as otherwise the effective head is reduced, with considerable loss of efficiency.

The nozzles may be placed either above or below the wheel, depending on the direction of rotation required.

**Control of Tangential Water-Wheels.** — The methods of regulating tangential water-wheels may be classified under five heads:

1. Permanently or semi-permanently altering the area of efflux of the nozzles, with water economy and without loss of efficiency.

2. Reducing the volume of flow without altering the area of efflux, with water economy but with loss of efficiency.

3. Variable alteration of the area of efflux without loss of efficiency and with water economy.

4. Deflection of the jet, so that only a portion of its energy is transmitted to the wheel, without water economy.

5. Combined regulation of 3 and 4, producing an effect whereby the energy of the jet is reduced rapidly without water ram and the area of efflux reduced slowly to effect water economy, or by a combination of 3 with some form of by-pass.

*Governors.* — Of the five methods of control enumerated above, the first cannot be done automatically; the other four, however, are susceptible to either hand regulation or automatic regulation by means of governors, the function of the governor being merely to automatically bring into action the particular controlling device with which the wheel has been equipped. There are two leading types of governors, the hydraulic and the mechanical. In the first, the mechanism of the water-wheel regulator is actuated by a hydraulically operated piston, the motive power being taken from a small branch pipe from the main water supply, or from an independent high-pressure oil-pumping system, the position of the piston in the cylinder and consequent relative position of the controlling mechanism being dependent upon the amount of fluid under pressure admitted to the cylinder at either end. This is controlled by a main valve, operated by a very sensitive relay valve which, in turn, is directly controlled by the centrifugal balls of the governor.

The second type, or mechanically operated governor, consists of a device for automatically controlling and directing the transmission of the requisite amount of energy taken from the wheel shaft, to operate the water-regulating mechanism. The Lombard governor is a representative of the first type, and the Lombard-Replogle governor of the second.

The close regulation that can be obtained with the latter is remarkable. Any size will go into operation and make connection at so slight a deviation as one-tenth of one per cent from normal, and in installations which have been made they will not permit of a departure of more than five to eight per cent temporarily where there is an instantaneous drop from full load to practically no load. When there is sufficient fly-wheel effect, the deviation will not be over two per cent. The adoption of fly wheels greatly facilitates many problems of governing.



## Tangential Water-Wheel Table. (Joshua Hendy Iron Works.)

$P$  = horse-power,  $Q$  = cubic feet per minute,  $R$  = revs. per min. The smaller figures in the first column give the spouting velocity of the jet in feet per minute. (The table is greatly condensed from the original; 6-in., 15-in., and 30-in. wheels are also listed.  $P$  and  $Q$  are the same, with any given head, for a 30 as for a 36-in. wheel, but  $R$  is 20% greater.)

Head in Ft.		12 Inch.	18 Inch.	24 Inch.	36 Inch.	48 Inch.	60 Inch.	72 Inch.	8 Feet.	10 Feet.	12 Feet.
20 2152	P	.12	.37	.66	1.50	2.64	4.18	6.00	10.64	16.48	23.80
	Q	3.91	11.72	20.83	46.93	83.32	130.36	187.72	332.70	515.04	748.95
	R	342	228	171	114	85	70	57	43	34	29
30 2636	P	.23	.69	1.22	2.76	4.88	7.69	11.04	19.53	30.00	43.80
	Q	4.79	14.36	25.51	57.44	102.04	159.66	229.76	407.03	630.00	916.47
	R	418	279	209	139	104	83	69	52	41	35
40 3043	P	.35	1.06	1.89	4.24	7.58	11.85	16.96	30.08	46.60	67.60
	Q	5.53	16.59	29.45	66.36	107.84	184.36	265.44	470.27	728.16	1058.86
	R	484	323	242	161	121	96	80	62	49	40
50 3433	P	.49	1.49	2.65	5.98	10.60	16.63	23.93	42.05	65.00	94.50
	Q	6.18	18.54	32.93	74.17	131.72	206.13	296.70	525.90	814.32	1184.15
	R	541	361	270	180	135	108	90	69	55	46
60 3727	P	.65	1.96	3.48	7.84	13.94	21.77	31.36	55.20	85.62	124.50
	Q	6.77	20.31	36.08	81.25	144.32	225.80	325.00	576.00	892.00	1297.00
	R	592	395	296	197	148	118	98	75	60	50
70 4026	P	.82	2.47	4.39	9.88	17.58	27.51	39.52	70.00	107.80	157.50
	Q	7.31	21.94	38.97	87.76	155.88	243.89	351.04	624.00	966.24	1405.17
	R	640	427	320	2.13	160	130	106	81	64	54
80 4304	P	1.00	3.01	5.36	12.04	21.44	33.54	48.16	85.76	134.16	192.64
	Q	7.82	23.46	41.66	93.84	166.64	260.73	375.36	666.56	1042.92	1501.44
	R	684	456	342	228	171	137	114	87	69	58
90 4565	P	1.20	3.60	6.39	14.40	25.59	40.04	57.60	102.36	160.16	230.40
	Q	8.29	24.88	44.19	99.52	176.75	276.55	398.08	707.00	1106.20	1592.32
	R	726	484	363	242	181	145	121	93	73	62
100 4812	P	1.40	4.21	7.49	16.84	29.93	46.85	67.36	119.72	187.40	269.44
	Q	8.74	26.22	46.58	104.83	186.32	291.51	419.52	745.28	1166.04	1678.08
	R	765	510	382	255	191	152	127	96	77	64
120 5271	P	1.84	5.54	9.85	22.18	39.41	61.65	88.75	157.64	246.64	355.00
	Q	9.57	28.72	51.02	114.91	204.10	319.33	459.64	816.40	1277.32	1838.56
	R	838	559	419	279	209	167	139	105	83	70
140 5694	P	2.33	6.99	12.41	27.96	49.64	77.71	111.85	198.56	310.84	447.40
	Q	10.34	31.03	55.11	124.12	220.44	344.92	496.48	881.76	1379.68	1985.92
	R	906	604	453	302	226	181	151	114	90	75
160 6087	P	2.84	8.54	15.17	34.16	60.68	94.94	136.65	242.72	377.76	546.60
	Q	11.05	33.17	58.92	132.68	235.68	368.73	530.75	942.72	1474.92	2123.00
	R	969	646	484	323	242	193	161	121	97	81
180 6456	P	3.39	10.19	18.10	40.77	72.41	113.30	163.08	289.64	453.20	652.32
	Q	11.72	35.18	62.49	140.74	249.97	391.10	562.96	999.83	1564.40	2251.84
	R	1024	683	513	342	256	206	171	128	103	86
200 6805	P	3.97	11.93	21.20	47.75	84.81	132.70	191.00	339.24	530.80	764.00
	Q	12.36	37.08	65.87	148.35	263.49	412.25	593.40	1053.96	1649.00	2373.60
	R	1080	720	540	360	270	216	180	135	108	90
225 7215	P	.....	.....	.....	56.99	101.20	158.38	227.96	404.80	633.52	911.84
	Q	.....	.....	.....	157.33	279.44	437.23	629.32	1117.76	1748.92	2517.28
	R	.....	.....	.....	382	287	229	191	144	115	96
250 7698	P	5.56	16.68	29.63	66.74	118.54	185.47	266.96	474.16	741.88	1067.84
	Q	13.82	41.46	73.64	165.86	294.59	460.91	663.45	1178.36	1843.64	2653.80
	R	1209	806	605	403	302	241	202	151	121	101

Tangential Water-Wheel Table.—Continued.

Head in Ft.	Tangential Water-Wheel Table.—Continued.										
		12 Inch.	18 Inch.	24 Inch.	36 Inch.	48 Inch.	60 Inch.	72 Inch.	8 Feet.	10 Feet.	12 Feet.
275 7975	P	.....	.....	.....	77.00	136.76	214.00	308.00	547.04	856.00	1232.00
	Q	.....	.....	.....	173.94	308.92	483.39	695.76	1235.68	1933.56	2783.04
	R	.....	.....	.....	423	317	253	211	159	127	106
300 8335	P	7.31	21.93	38.95	87.73	155.83	243.82	350.94	623.32	975.28	1403.76
	Q	15.13	45.42	80.67	181.59	322.71	504.91	726.76	1290.84	2019.64	2907.04
	R	1326	884	663	442	331	265	221	166	133	111
325 8672	P	.....	.....	.....	98.93	175.68	274.94	395.72	702.72	1099.76	1582.88
	Q	.....	.....	.....	189.10	335.84	525.50	756.40	1343.36	2102.00	3025.60
	R	.....	.....	.....	460	344	276	230	172	138	115
350 9002	P	9.21	27.64	49.09	110.56	196.38	307.25	442.27	785.52	1229.00	1769.08
	Q	16.35	49.06	87.14	196.25	348.57	545.36	785.00	1394.28	2181.44	3140.00
	R	1432	955	716	477	358	275	238	179	143	119
400 9624	P	11.25	33.77	59.98	135.08	239.94	375.40	540.35	959.76	1501.60	2161.40
	Q	17.48	52.45	93.16	209.80	372.64	583.02	839.20	1490.56	2332.08	3356.80
	R	1531	1021	765	510	382	306	255	101	153	128
450 10208	P	13.43	40.79	71.57	161.19	286.31	447.95	644.78	1145.24	1791.80	2579.12
	Q	18.54	55.63	98.81	222.52	395.24	618.38	890.11	1580.96	2473.52	3560.44
	R	1624	1083	812	541	406	324	270	203	162	135
500 10760	P	15.73	47.20	83.83	188.80	335.34	524.66	755.20	1341.36	2098.64	3020.80
	Q	19.54	58.64	104.15	234.56	416.62	651.83	938.25	1666.48	2607.02	3753.00
	R	1713	1142	856	571	428	342	285	214	171	143
550 11279	P	.....	.....	.....	217.82	386.84	605.31	871.28	1547.36	2421.24	3485.12
	Q	.....	.....	.....	246.00	436.92	683.62	984.00	1747.68	2734.48	3936.00
	R	.....	.....	.....	599	449	359	299	225	179	150
600 11787	P	24.26	62.04	110.19	248.16	440.77	689.63	992.65	1763.08	2758.52	3970.60
	Q	25.12	64.24	114.09	256.95	456.38	714.05	1027.80	1825.52	2856.20	4111.20
	R	1876	1251	938	625	469	375	312	235	188	156
640 12169	P	.....	.....	.....	270.97	484.16	748.80	1083.88	1936.64	2995.20	4335.52
	Q	.....	.....	.....	264.63	466.12	731.59	1058.52	1864.48	2926.36	4234.08
	R	.....	.....	.....	644	483	387	322	242	194	161
700 12731	P	30.57	78.18	138.86	312.73	555.46	869.06	1250.92	2221.84	3476.24	5003.68
	Q	27.13	69.38	123.23	277.54	492.95	771.26	1110.16	1971.80	3085.04	4440.64
	R	2026	1351	1013	675	506	405	337	253	203	169
750 13178	P	33.91	86.70	154.00	346.83	616.03	963.82	1387.34	2464.12	3855.28	5549.36
	Q	28.08	71.82	127.56	287.28	510.25	798.33	1149.13	2041.00	3193.32	4596.52
	R	2098	1309	1049	699	524	419	349	262	210	175
800 13610	P	37.35	95.52	169.66	382.09	678.66	1061.81	1528.36	2714.64	4247.24	6113.44
	Q	29.00	74.17	131.74	296.70	526.99	824.51	1186.81	2107.96	3298.04	4747.24
	R	2166	1444	1083	722	542	433	361	271	217	181
900 14436	P	44.57	113.98	202.45	455.94	809.82	1267.02	1823.76	3239.28	5068.08	7295.04
	Q	30.76	78.67	139.74	314.70	558.96	874.53	1258.81	2235.84	3498.12	5035.24
	R	2298	1532	1149	766	574	459	383	287	229	192
1000 15217	P	52.20	133.50	237.12	534.01	948.48	1483.97	2136.04	3793.92	5935.88	8544.16
	Q	32.42	82.93	147.30	331.72	589.19	921.83	1326.91	2356.76	3687.32	5287.64
	R	2420	1615	1210	807	605	484	403	303	242	202

The above tables are compiled on the following basis:

The head ( $h$ ) is the net effective head at the nozzle. Proper allowance must be made for all losses in the pipe line.

The velocity of efflux ( $V$ ) is the approximate spouting velocity of the jet in feet per minute as it issues from the nozzle =  $\sqrt{2gh} \times 60 = 481.2\sqrt{h}$ .

The discharge in cubic feet per minute =  $Q = V \times a$ , where  $a$  equals the cross-section area of nozzle opening in sq. ft., no allowance being made for friction in the nozzle.

The weight of a cubic foot of water is taken at 39.2° Fahr. = 62.425 lbs.

The theoretical horse-power =  $Q \times 62.425 \times h \div 33.000 = 0.00189 Qh$ .

The horse-power in the tables is based on 85% mechanical efficiency for the wheels.

The diameter is the effective diameter at the line of the nozzle center, where the jet impinges on the center of the bucket.

The number of revolutions is based on a peripheral speed for the effective diameter, of half the velocity of efflux of the jet, and equals  $V \div 2 C$ , where  $C$  = the circumference (in feet) of the effective diameter.

Small wheels, up to 24-in. diam., are commonly called motors.

**Amount of Water Required to Develop a Given Horse-Power, with a Given Available Effective Head.**

Effective Head in Feet.	Horse-Power Based on 85% Efficiency of the Water Wheel.									
	10	20	30	40	50	60	70	80	90	100
	Flow in Cubic Feet of Water per Minute Required to Develop Power.									
50.....	125	250	375	500	625	750	875	1000	1125	1250
60.....	104	208	312	416	520	624	726	830	934	1038
70.....	88	177	266	355	444	532	621	709	798	886
80.....	77	155	232	311	388	466	544	622	699	876
90.....	70	140	210	280	350	420	490	560	630	700
100.....	63	125	186	248	312	372	435	498	558	622
110.....	59	118	176	234	293	350	410	467	525	585
120.....	52	104	156	208	260	312	364	415	467	520
130.....	48	96	143	192	240	287	335	385	430	478
140.....	45	89	133	178	222	266	310	355	400	443
150.....	42	83	125	166	208	250	292	332	375	416
160.....	39	78	117	155	195	233	272	312	350	388
170.....	37	73	110	146	183	220	256	293	330	365
180.....	35	69	104	138	172	207	242	276	310	345
190.....	33	65	98	132	164	198	230	262	295	326
200.....	31	62	93	124	155	186	218	248	280	310
210.....	30	59	89	118	148	177	206	236	266	295
220.....	28	57	85	113	141	169	198	225	255	283
230.....	27	54	81	108	135	162	190	216	243	270
240.....	26	52	78	104	130	155	181	207	233	258
250.....	25	50	75	100	125	149	174	199	224	248
260.....	24	48	72	96	120	144	167	191	215	238
270.....	23	46	69	92	115	138	161	184	207	230
280.....	22	45	67	89	111	133	156	178	200	222
290.....	21	43	65	86	107	129	150	172	193	215
300.....	20	42	62	83	104	124	145	166	187	208
310.....	19	41	60	80	100	120	140	160	180	200
320.....	19	40	59	78	97	117	136	156	175	194
330.....	19	38	57	76	94	113	132	151	170	188
340.....	18	37	55	74	92	110	128	146	165	183
350.....	18	36	53	71	89	106	124	142	160	178
360.....	18	35	52	69	86	102	121	138	155	172
370.....	17	34	50	67	84	100	117	134	151	168
380.....	17	33	49	66	82	98	114	130	147	164
390.....	16	32	48	64	80	96	111	127	144	160
400.....	16	31	47	63	77	94	105	124	140	156

**Efficiency of the Doble Nozzle.**—The nozzle tip is of brass, highly polished in the interior, with concave curves near the end. It contains a conical regulating needle, which is set at any desired distance from the opening to regulate the size of the opening and the diameter of the jet. A jet flowing from the nozzle has a clear, glassy appearance. Tests



by H. C. Crowell and G. C. D. Lenth, at Mass. Inst. of Tech., 1903, gave efficiencies under constant head from 96.4 to 99.3% for different settings of the needle, the coefficient of velocity being from 0.982 to 0.997. The efficiency of a jet is equal to the ratio of the velocity head in the jet to the total head at the entrance to the nozzle, and equal to the square of the coefficient of velocity. — *Bulletin of the Abner Doble Co.*, No. 6, 1904.

**Tests of a 12-in. Doble Laboratory Motor** (*Bulletin* No. 12, 1908, Abner Doble Co.).—The tests were made by students at the University of Missouri. The available head was 46 ft. The needle valve was opened two, four, six and eight turns in the four series of tests, and with each opening different loads were applied by a Prony brake. The results were recorded and plotted in curves showing the relation of speed, load and efficiency, and from these curves the following approximate figures are taken:

		Speed, Revolutions per Minute.						
		200	300	400	500	600	700	800
Valve open	.....	200	300	400	500	600	700	800
Two turns	{ B.H.P. ....	0.20	0.26	0.27	0.26	0.22	0.14	0.03
	{ Effy. % ....	62	75	80	77	64	41	13
Four turns	{ B.H.P. ....	0.36	0.45	0.51	0.50	0.42	0.30	0.12
	{ Effy. % ....	57	75	85	85	71	50	19
Six turns	{ B.H.P. ....	0.41	0.55	0.63	0.66	0.60	0.41	0.20
	{ Effy. % ....	48	64	73	76	74	66	51
Eight turns	{ B.H.P. ....	0.48	0.62	0.70	0.71	0.64	0.43	0.19
	{ Effy. % ....	53	70	79	81	72	50	23

**Water-power Plants Operating under High Pressures.**—The following notes are contributed by the Pelton Water Wheel Co.:

The Consolidated Virginia & Col. Mining Co., Virginia, Nev., has a 3-ft. steel-disk Pelton wheel operating under 2100 ft. fall, equal to 911 lbs. per sq. in. It runs at a peripheral velocity of 10,804 ft. per minute and has a capacity of over 100 H.P. The rigidity with which water under such a high pressure as this leaves the nozzle is shown in the fact that it is impossible to cut the stream with an axe, however heavy the blow, as it will rebound just as it would from a steel rod travelling at a high rate of speed.

The London Hydraulic Power Co. has a large number of Pelton wheels from 12 to 18 in. diameter running under pressure of about 1000 lbs. per sq. in. from a system of pressure-mains. The 18-in. wheels weighing 30 lbs. have a capacity of over 20 H.P. (See Blaine's "Hydraulic Machinery.")

Hydraulic Power-hoist of Milwaukee Mining Co., Idaho.—One cage travels up as the other descends; the maximum load of 5500 lbs. at a speed of 400 ft. per min. is carried by one of a pair of Pelton wheels (one for each cage). Wheels are started and stopped by opening and closing a small hydraulic valve at the engineer's stand which operates the larger valves by hydraulic pressure. An air-chamber takes up the shock that would otherwise occur on the pipe line under the pressure due to 850 ft. fall.

The Mannesmann Cycle Tube Works, North Adams, Mass., are using four Pelton wheels, having a fly-wheel rim, under a pump pressure of 600 lbs. per sq. in. These wheels are direct-connected to the rolls through which the ingots are passed for drawing out seamless tubing.

The Alaska Gold Mining Co., Douglass Island, Alaska, has a 22-ft. Pelton wheel on the shaft of a Riedler duplex compressor. It is used as a fly-wheel as well, weighing 25,000 lbs., and develops 500 H.P. at 75 revolutions. A valve connected to the pressure-chamber starts and stops the wheel automatically, thus maintaining the pressure in the air-receiver.

At Pachuca in Mexico five Pelton wheels having a capacity of 600 H.P. each under 800 ft. head are driving an electric transmission plant. These wheels weigh less than 500 lbs. each, showing over a horse-power per pound of metal.

**Formulae for Calculating the Power of Jet Water-wheels**, such as the Pelton (F. K. Blue).— $HP$  = horse-power delivered;  $\delta$  = 62.36 lbs. per cu. ft.;  $E$  = efficiency of turbine;  $q$  = quantity of water, cubic feet per minute;  $h$  = feet effective head;  $d$  = inches diameter of jet;  $p$  = pounds per square inch effective head;  $c$  = coefficient of discharge from nozzle, which may be ordinarily taken at 0.9.

$$HP = \frac{\delta Eqh}{33000} = .00189Eqh = .00436 Eqp = .00496 Ecd^2 \sqrt{h^3} = .0174 Ecd^2 \sqrt{p^3}.$$

$$q = 529.2 \frac{HP}{Eh} = 229 \frac{HP}{Ep} = 2.62 cd^2 \sqrt{h} = 3.99 cd^2 \sqrt{p}.$$

$$d^2 = 201.6 \frac{HP}{Ec \sqrt{h^3}} = 57.4 \frac{HP}{Ec \sqrt{p^3}} = 0.381 \frac{q}{c \sqrt{h}} = 0.25 \frac{q}{c \sqrt{p}}.$$

### THE POWER OF OCEAN WAVES.

Albert W. Stahl, U. S. N. (*Trans. A. S. M. E.*, xiii. 438), gives the following formulæ and table, based upon a theoretical discussion of wave motion:

The total energy of one whole wave-length of a wave  $H$  feet high,  $L$  feet long, and one foot in breadth, the length being the distance between successive crests, and the height the vertical distance between the crest and the trough, is  $E = 8 LH^2 \left(1 - 4.935 \frac{H^2}{L^2}\right)$  foot-pounds.

The time required for each wave to travel through a distance equal to its own length is  $P = \sqrt{\frac{L}{5.123}}$  seconds, and the number of waves passing any given point in one minute is  $N = \frac{60}{P} = 60 \sqrt{\frac{5.123}{L}}$ . Hence the total energy of an indefinite series of such waves, expressed in horse-power per foot of breadth, is

$$\frac{E \times N}{33,000} = 0.0329 \frac{H^2 L}{\sqrt{L}} \left(1 - 4.935 \frac{H^2}{L^2}\right).$$

By substituting various values for  $H \div L$ , within the limits of such values actually occurring in nature, we obtain the following table of

TOTAL ENERGY OF DEEP-SEA WAVES IN TERMS OF HORSE-POWER PER FOOT OF BREADTH.

Ratio of Length to Height of Waves.	Length of Waves in Feet.							
	25	50	75	100	150	200	300	400
50	0.04	0.23	0.64	1.31	3.62	7.43	20.46	42.01
40	0.06	0.36	1.00	2.05	5.65	11.59	31.95	65.58
30	0.12	0.64	1.77	3.64	10.02	20.57	56.70	116.38
20	0.25	1.44	3.96	8.13	21.79	45.98	120.70	260.08
15	0.42	2.83	6.97	14.31	39.43	80.94	223.06	457.89
10	0.98	5.53	15.24	31.29	86.22	177.00	487.75	1001.25
5	3.30	18.68	51.48	105.68	291.20	597.78	1647.31	3381.60

The figures are correct for trochoidal deep-sea waves only, but they give a close approximation for any nearly regular series of waves in deep water and a fair approximation for waves in shallow water.

The question of the practical utilization of the energy which exists in ocean waves divides itself into several parts:

1. The various motions of the water which may be utilized for power purposes.

2. The wave-motor proper. That is, the portion of the apparatus in direct contact with the water, and receiving and transmitting the energy thereof; together with the mechanism for transmitting this energy to the machinery for utilizing the same.

3. Regulating devices, for obtaining a uniform motion from the irregular and more or less spasmodic action of the waves, as well as for adjusting the apparatus to the state of the tide and condition of the sea.

4. Storage arrangements for insuring a continuous and uniform output of power during a calm, or when the waves are comparatively small.

The motions that may be utilized for power purposes are the following:

1. Vertical rise and fall of particles at and near the surface. 2. Horizontal to-and-fro motion of particles at and near the surface. 3. Varying slope of surface of wave. 4. Impetus of waves rolling up the beach in the form of breakers. 5. Motion of distorted verticals. All of these motions, except the last one mentioned, have at various times been proposed to be utilized for power purposes; and the last is proposed to be used in apparatus described by Mr. Stahl.

The motion of distorted verticals is thus defined: A set of particles, originally in the same vertical straight line when the water is at rest, does not remain in a vertical line during the passage of the wave; so that the line connecting a set of such particles, while vertical and straight in still water, becomes distorted, as well as displaced, during the passage of the wave, its upper portion moving farther and more rapidly than its lower portion.

Mr. Stahl's paper contains illustrations of several wave-motors designed upon various principles. His conclusion as to their practicability is as follows: "Possibly none of the methods described in this paper may ever prove commercially successful; indeed the problem may not be susceptible of a financially successful solution. My own investigations, however, so far as I have yet been able to carry them, incline me to the belief that wave-power can and will be utilized on a paying basis."

**Continuous Utilization of Tidal Power.** (P. Decœur, *Proc. Inst. C. E.* 1890.) — In connection with the training-walls to be constructed in the estuary of the Seine, it is proposed to construct large basins, by means of which the power available from the rise and fall of the tide could be utilized. The method proposed is to have two basins separated by a bank rising above high water, within which turbines would be placed. The upper basin would be in communication with the sea during the higher one-third of the tidal range, rising, and the lower basin during the lower one-third of the tidal range, falling. If  $H$  be the range in feet, the level in the upper basin would never fall below  $\frac{2}{3}H$  measured from low water, and the level in the lower basin would never rise above  $\frac{1}{3}H$ . The available head varies between  $0.53H$  and  $0.80H$ , the mean value being  $\frac{2}{3}H$ . If  $S$  square feet be the area of the lower basin, and the above conditions are fulfilled, a quantity  $\frac{1}{3}SH$  cu. ft. of water is delivered through the turbines in the space of  $9\frac{1}{4}$  hours. The mean flow is, therefore,  $SH \div 99,900$  cu. ft. per sec., and, the mean fall being  $\frac{2}{3}H$ , the available gross horse-power is about  $\frac{1}{30}S'H^2$ , where  $S'$  is measured in acres. This might be increased by about one-third if a variation of level in the basins amounting to  $\frac{1}{2}H$  were permitted. But to reach this end the number of turbines would have to be doubled, the mean head being reduced to  $\frac{1}{2}H$ , and it would be more difficult to transmit a constant power from the turbines. The turbine proposed is of an improved model designed to utilize a large flow with a moderate diameter. One has been designed to produce 300 horse-power, with a minimum head of 5 ft. 3 in. at a speed of 15 revolutions per minute, the vanes having 13 ft. internal diameter. The speed would be maintained constant by regulating sluices.



PUMPS AND PUMPING ENGINES.

**Theoretical Capacity of a Pump.** — Let  $Q'$  = cu. ft. per min.;  $G'$  = U. S. gals. per min. = 7.4805  $Q'$ ;  $d$  = diam. of pump in inches;  $l$  = stroke in inches;  $N$  = number of single strokes per min.

Capacity in cu. ft. per min.  $= Q' = \frac{\pi}{4} \cdot \frac{d^2}{144} \cdot \frac{lN}{12} = 0.0004545 N d^2 l$ ;

Capacity in U. S. gals. per min.  $G' = \frac{\pi}{4} \cdot \frac{N d^2 l}{231} \dots\dots = 0.0034 N d^2 l$ ;

Capacity in gals. per hour  $\dots\dots\dots = 0.204 N d^2 l$ .

Diameter required for a }  $d = 46.9 \sqrt{\frac{Q'}{Nl}} = 17.15 \sqrt{\frac{G'}{Nl}}$   
 given capacity per min. }

If  $v$  = piston speed in feet per min.,  $d = 13.54 \sqrt{\frac{Q'}{v}} = 4.95 \sqrt{\frac{G'}{v}}$ .

If the piston speed is 100 feet per min.:

$Nl = 1200$ , and  $d = 1.354 \sqrt{Q'} = 0.495 \sqrt{G'}$ ;  $G' = 4.08 d^2$  per min.

The actual capacity will be from 60% to 95% of the theoretical, according to the tightness of the piston, valves, suction-pipe, etc.

**Theoretical Horse-power Required to Raise Water to a Given Height.** — Horse-power =

Volume in cu. ft. per min.  $\times$  pressure per sq. ft.  $= \frac{\text{Weight} \times \text{height of lift}}{33,000}$ .

$Q'$  = cu. ft. per min.;  $G'$  = gals. per min.;  $W$  = wt. in lbs.;  $P$  = pressure in lbs. per sq. ft.;  $p$  = pressure in lbs. per sq. in.;  $H$  = height of lift in ft.;  $W = 62.355 Q'$ ,  $P = 144 p$ ,  $p = 0.433 H$ ,  $H = 2.3094 p$ ,  $G' = 7.4805 Q'$ .

HP.  $= \frac{Q'P}{33,000} = \frac{Q'H \times 144 \times 0.433}{33,000} = \frac{Q'H}{529.23} = \frac{G'H}{3958.9} = \frac{1.0104 G'H}{4000}$

HP.  $= \frac{WH}{33,000} = \frac{Q' \times 62.355 \times 2.3094 p}{33,000} = \frac{Q'p}{229.17} = \frac{G'p}{1714.3}$ .

For the actual horse-power required an allowance must be made for the friction, slips, etc., of engine, pump, valves, and passages.

**Depth of Suction.** — Theoretically a perfect pump will draw water from a height of nearly 34 feet, or the height corresponding to a perfect vacuum (14.7 lbs.  $\times$  2.309 = 33.95 feet); but since a perfect vacuum cannot be obtained on account of valve-leakage, air contained in the water, and the vapor of the water itself, the actual height is generally less than 30 feet. When the water is warm the height to which it can be lifted by suction decreases, on account of the increased pressure of the vapor. In pumping hot water, therefore, the water must flow into the pump by gravity. The following table shows the theoretical maximum depth of suction for different temperatures, leakage not considered:

Temp. Fahr.	Absolute Pressure of Vapor, lbs. per sq. in.	Vacuum in Inches of Mercury.	Max. Depth of Suction, feet.	Temp. Fahr.	Absolute Pressure of Vapor, lbs. per sq. in.	Vacuum in Inches of Mercury.	Max. Depth of Suction, feet.
102.1	1	27.88	31.6	182.9	8	13.63	15.4
126.3	2	25.85	29.3	188.3	9	11.60	13.1
141.6	3	23.83	27.0	193.2	10	9.56	10.8
153.1	4	21.78	24.7	197.8	11	7.52	8.5
162.3	5	19.74	22.3	202.0	12	5.49	6.2
170.1	6	17.70	20.0	205.9	13	3.45	3.9
176.9	7	15.67	17.7	209.6	14	1.41	1.6

**The Deane Single Boiler-feed or Pressure Pump.** — Suitable for pumping clear liquids at a pressure not exceeding 150 lbs.

Number.	Sizes.			Capacity per min. at Given Speed.		Length in inches.	Width in inches.	Sizes of Pipes.				
	Steam-cyl-inder.	Water-cyl-inder.	Length of Stroke.	Gallons per Stroke.	Strokes.			Gallons.	Steam.	Exhaust.	Suction.	Discharge.
0	3	2	5	.07	150	10	29 1/2	7	1/2	3/4	11/4	1
1	3 1/2	2 1/4	5	.09	150	13	33 1/2	7 1/2	1/2	3/4	11/4	1
1 1/2	4	2 3/8	5	.10	150	15	33 1/2	7 1/2	1/2	3/4	11/4	1
2	4	2 1/2	5	.11	150	16	33 1/2	7 1/2	1/2	3/4	11/4	1
2 1/2	4 3/4	3	5	.15	150	22	34	8 1/2	1/2	3/4	11/4	1 1/4
3	5	3 1/4	7	.25	125	31	43 1/2	9 1/4	3/4	1	2	1 1/2
4	5 1/2	3 3/4	7	.33	125	42	43 1/2	9 1/4	3/4	1	2	1 1/2
4 1/2	7	4 1/4	8	.49	120	58	51 1/2	12	1	1 1/2	3	2
5	7	4 1/2	10	.69	100	69	55	12	1	1 1/2	3	2
6	7 1/2	5	10	.85	100	85	55	12	1	1 1/2	3	2
6 1/2	8	5	12	1.02	100	102	63	14	1	1 1/2	3	2 1/2
7	10	6	12	1.47	100	147	69	19	1 1/2	2	4	4
8	12	7	12	2.00	100	200	69	19	2	2 1/2	5	4
9	14	8	12	2.61	100	261	69	21	2	2 1/2	5	5

**The Deane Single Tank or Light-service Pump.** — These pumps will all stand a constant working pressure of 75 lbs. on the water-cylinders.

Steam-cyl-inder.	Sizes.			Capacity per min. at Given Speed.		Length in inches.	Width in inches.	Sizes of Pipes.			
	Water-cyl-inder.	Length of Stroke.	Gallons per Stroke.	Strokes.	Gallons.			Steam.	Exhaust.	Suction.	Discharge.
4	4	5	.27	130	35	33	9 1/2	1/2	3/4	2	1 1/2
5	4	7	.38	125	48	45 1/2	15	3/4	1	3	2 1/2
5 1/2	5 1/2	7	.72	125	90	45 1/2	15	3/4	1	3	2 1/2
7 1/2	7 1/2	10	1.91	110	210	58	17	1	1 1/2	5	4
8	6	12	1.46	100	146	67	20 1/2	1	1 1/2	4	4
6	7	12	2.00	100	200	66	17	3/4	1	4	4
8	7	12	2.00	100	200	67	20 1/2	1	1 1/2	5	4
8	8	12	2.61	100	261	68	30	1	1 1/2	5	5
10	8	12	2.61	100	261	68 1/2	30	1 1/2	2	5	5
8	10	12	4.08	100	408	68	20 1/2	1	1 1/2	8	8
10	10	12	4.08	100	408	68 1/2	30	1 1/2	2	8	8
12	10	12	4.08	100	408	64	24	2	2 1/2	8	8
10	12	12	5.87	100	587	68 1/2	30	1 1/2	2	8	8
12	12	12	5.87	100	587	64	28 1/2	2	2 1/2	8	8
10	12	18	8.79	70	616	95	25	1 1/2	2	8	8
12	12	18	8.79	70	616	95	28 1/2	2	2 1/2	8	8
12	14	18	12.00	70	840	95	28 1/2	2	2 1/2	8	8
14	16	18	15.66	70	1096	95	34	2	2 1/2	12	10
16	16	18	15.66	70	1096	95	34	2	2 1/2	12	10
18	16	18	15.66	70	1096	97	34	3	3 1/2	12	10
16	18	24	26.42	50	1321	115	40	2	2 1/2	14	12
18	18	24	26.42	50	1321	135	40	3	3 1/2	14	12

**Amount of Water raised by a Single-acting Lift-pump.** — It is common to estimate that the quantity of water raised by a single-acting bucket-valve pump per minute is equal to the number of strokes in one direction per minute, multiplied by the volume traversed by the piston in a single stroke, on the theory that the water rises in the pump only when the piston or bucket ascends; but the fact is that the column of water does not cease flowing when the bucket descends, but flows on continuously through the valve in the bucket, so that the discharge of the pump, if it is operated at a high speed, may amount to considerably more than that calculated from the displacement multiplied by the number of single strokes in one direction.

**Proportioning the Steam-cylinder of a Direct-acting Pump.** — Let

$A$  = area of steam-cylinder;                       $a$  = area of pump-cylinder;  
 $D$  = diameter of steam-cylinder;               $d$  = diameter of pump-cylinder;  
 $P$  = steam-pressure, lbs. per sq. in.;       $p$  = resistance per sq. in. on pumps;  
 $H$  = head = 2.309  $p$ ;                                       $p = 0.433 H$ ;

$E$  = efficiency of the pump =  $\frac{\text{work done in pump-cylinder}}{\text{work done by the steam-cylinder}}$ .

$$A = \frac{ap}{EP}; a = \frac{EAP}{p}; D = d \sqrt{\frac{p}{EP}}; d = D \sqrt{\frac{EP}{p}}; P = \frac{ap}{EA}; p = \frac{EAP}{a}.$$

$$\frac{A}{a} = \frac{p}{EP} = \frac{0.433 H}{EP}; H = 2.309 EP \frac{A}{a}. \text{ If } E = 75\%, H = 1.732 P \frac{A}{a}.$$

$E$  is commonly taken at 0.7 to 0.8 for ordinary direct-acting pumps. For the highest class of pumping-engines it may amount to 0.9. The steam-pressure  $P$  is the mean effective pressure, according to the indicator-diagram; the water-pressure  $p$  is the mean total pressure acting on the pump plunger or piston, including the suction, as could be shown by an indicator-diagram of the water-cylinder. The pressure on the pump-piston is frequently much greater than that due to the height of the lift, on account of the friction of the valves and passages, which increases rapidly with velocity of flow.

**Speed of Water through Pipes and Pump-passages.** — The speed of the water is commonly from 100 to 200 feet per minute. If 200 feet per minute is exceeded, the loss from friction may be considerable.

The diameter of pipe required is  $4.95 \sqrt{\frac{\text{gallons per minute}}{\text{velocity in feet per minute}}}$ .

For a velocity of 200 feet per minute, diam. =  $0.35 \times \sqrt{\text{gallons per min.}}$

**Sizes of Direct-acting Pumps.** — The tables on pages 789 and 791 are selected from catalogues of manufacturers, as representing the two common types of direct-acting pump, viz., the single-cylinder and the duplex. Both types are made by most of the leading manufacturers.

**Efficiency of Small Direct-acting Pumps.** — Chas. E. Emery, in Reports of Judges of Philadelphia Exhibition, 1876, Group xx., says: "Experiments made with steam-pumps at the American Institute Exhibition of 1867 showed that average-sized steam-pumps do not, on the average, utilize more than 50 per cent of the indicated power in the steam-cylinders, the remainder being absorbed in the friction of the engine, but more particularly in the passage of the water through the pump. It may be safely stated that ordinary steam-pumps rarely require less than 120 pounds of steam per hour for each horse-power utilized in raising water, equivalent to a duty of only 15,000,000 foot-pounds per 100 pounds of coal. With larger steam-pumps, particularly when they are proportioned for the work to be done, the duty will be materially increased."



The Worthington Duplex Pump.

STANDARD SIZES FOR ORDINARY SERVICE.

Diameter of Steam-cylinders.	Diameter of Water-plungers.	Length of Stroke.	Displacement in Gallons per Stroke of One Plunger.	Proper Strokes per Minute of One Plunger, varying with kind of work and pressure.	Gallons delivered per Minute by both Plungers at stated Number of Strokes.	Diameter of Plunger required in any single-cylinder pump to do the same work at same speed.	Sizes of Pipes for Short Lengths. To be increased as length increases.			
							Steam-pipe.	Exhaust-pipe.	Suction-pipe.	Discharge-pipe.
3	2	3	.04	100 to 250	8 to 20	2 7/8	3/8	1/2	1 1/4	1
4 1/2	2 3/4	4	.10	100 to 200	20 to 40	4	1/2	3/4	2	1 1/2
5 1/4	3 1/2	5	.20	100 to 200	40 to 80	5	3/4	1 1/4	2 1/2	1 3/2
6	4	6	.33	100 to 150	70 to 100	5 5/8	1	1 1/2	3	2
7 1/2	4 1/2	6	.42	100 to 150	85 to 125	6 3/8	1 1/2	2	4	3
7 1/2	5	6	.51	100 to 150	100 to 150	7	1 1/2	2	4	3
7 1/2	4 1/2	10	.69	75 to 125	100 to 170	6 3/8	1 1/2	2	4	3
9	5 1/4	10	.93	75 to 125	135 to 230	7 1/2	2	2 1/2	4	3
10	6	10	1.22	75 to 125	180 to 300	8 1/2	2	2 1/2	5	4
10	7	10	1.66	75 to 125	245 to 410	9 7/8	2	2 1/2	6	5
12	7	10	1.66	75 to 125	245 to 410	9 7/8	2 1/2	3	6	5
14	7	10	1.66	75 to 125	245 to 410	9 7/8	2 1/2	3	6	5
12	8 1/2	10	2.45	75 to 125	365 to 610	12	2 1/2	3	6	5
14	8 1/2	10	2.45	75 to 125	365 to 610	12	2 1/2	3	6	5
16	8 1/2	10	2.45	75 to 125	365 to 610	12	2 1/2	3	6	5
18 1/2	8 1/2	10	2.45	75 to 125	365 to 610	12	3	3 1/2	6	5
20	8 1/2	10	2.45	75 to 125	365 to 610	12	4	5	6	5
12	10 1/4	10	3.57	75 to 125	530 to 890	14 1/4	2 1/2	3	8	7
14	10 1/4	10	3.57	75 to 125	530 to 890	14 1/4	2 1/2	3	8	7
16	10 1/4	10	3.57	75 to 125	530 to 890	14 1/4	2 1/2	3	8	7
18 1/2	10 1/4	10	3.57	75 to 125	530 to 890	14 1/4	3	3 1/2	8	7
20	10 1/4	10	3.57	75 to 125	530 to 890	14 1/4	4	5	8	7
14	12	10	4.89	75 to 125	730 to 1220	17	2 1/2	3	10	8
16	12	10	4.89	75 to 125	730 to 1220	17	2 1/2	3	10	8
18 1/2	12	10	4.89	75 to 125	730 to 1220	17	3	3 1/2	10	8
20	12	10	4.89	75 to 125	730 to 1220	17	4	5	10	8
18 1/2	14	10	6.66	75 to 125	990 to 1660	19 3/4	3	3 1/2	12	10
20	14	10	6.66	75 to 125	990 to 1660	19 3/4	4	5	12	10
17	10	15	5.10	50 to 100	510 to 1020	14	3	3 1/2	8	7
20	12	15	7.34	50 to 100	730 to 1460	17	4	5	12	10
20	15	15	11.47	50 to 100	1145 to 2290	21	.....	.....	.....	.....
25	15	15	11.47	50 to 100	1145 to 2290	21	.....	.....	.....	.....

Speed of Piston. — A piston speed of 100 feet per minute is commonly assumed as correct in practice, but for short-stroke pumps this gives too high a speed of rotation, requiring too frequent a reversal of the valves. For long-stroke pumps, 2 feet and upward, this speed may be considerably exceeded, if valves and passages are of ample area.

**Number of Strokes Required to Attain a Piston Speed from 50 to 125 Feet per Minute for Pumps Having Strokes from 3 to 18 Inches in Length.**

Speed of Piston, in Feet per Min.	Length of Stroke in Inches.									
	3	4	5	6	7	8	10	12	15	18
	Number of Strokes per Minute.									
50	200	150	120	100	86	75	60	50	40	33
55	220	165	132	110	94	82.5	66	55	44	37
60	240	180	144	120	103	90	72	60	48	40
65	260	195	156	130	111	97.5	78	65	52	43
70	280	210	168	140	120	105	84	70	56	47
75	300	225	180	150	128	112.5	90	75	60	50
80	320	240	192	160	137	120	96	80	64	53
85	340	255	204	170	146	127.5	102	85	68	57
90	360	270	216	180	154	135	108	90	72	60
95	380	285	228	190	163	142.5	114	95	76	63
100	400	300	240	200	171	150	120	100	80	67
105	420	315	252	210	180	157.5	126	105	84	70
110	440	330	264	220	188	165	132	110	88	73
115	460	345	276	230	197	172.5	138	115	92	77
120	480	360	288	240	206	180	144	120	96	80
125	500	375	300	250	214	187.5	150	125	100	83

**Underwriters' Pumps — Standard Sizes.**  
(National Board of Fire Underwriters, 1908.)

Pump Sizes, In.			Capacity at 100 Lb. at Pump.			Boiler Power Required.		Full Speed.	
Steam.	Water.	Stroke	No. of 1 1/2-In. Streams.	Nominal Gals. per Min.	Actual Gals. per Min.	Horse-Power.	Steam Pressure at Pump, Lb.	Revs. per Min.	Piston Speed, Ft. per Min.
14	× 7	× 12	Two	500	483	100	40	70	140
14	× 7 1/4	× 12							
16	× 9	× 12	Four	1000	999	150	45	70	140
18	× 20	× 12							
18 1/2	× 10 1/4	× 12							
20	× 12	× 16							

The standard allowance for a good 1 1/8-in. (smooth nozzle) fire-stream is 250 gal. per minute.

**Piston Speed of Pumping-engines.** — (John Birkinbine, *Trans. A. I. M. E.*, v. 459.) — In dealing with such a ponderous and unyielding substance as water there are many difficulties to overcome in making a pump work with a high piston speed. The attainment of moderately high speed is, however, easily accomplished. Well-proportioned pumping-engines of large capacity, provided with ample water-ways and properly constructed valves, are operated successfully against heavy pressures at a speed of 250 ft. per minute, without "thug," concussion, or injury to the apparatus, and there is no doubt that the speed can be still further increased.

**Speed of Water through Valves.** — If areas through valves and water passages are sufficient to give a velocity of 250 ft. per min. or less, they are ample. The water should be carefully guided and not too abruptly deflected. (F. W. Dean, *Eng. News*, Aug. 10, 1893)

**Boiler-fed Pumps.** — Practice has shown that 100 ft. of piston speed per minute is the limit, if excessive wear and tear is to be avoided.

The velocity of water through the suction-pipe must not exceed 200 ft. per minute, else the resistance of the suction is too great.

The approximate size of suction-pipe, where the length does not exceed 25 ft. and there are not more than two elbows, may be found as follows:

$\frac{7}{10}$  of the diameter of the cylinder multiplied by  $\frac{1}{100}$  of the piston speed in feet. For duplex pumps of small size, a pipe one size larger is usually employed. The velocity of flow in the discharge-pipe should not exceed 500 ft. per minute. The volume of discharge and length of pipe vary so greatly in different installations that where the water is to be forced more than 50 ft. the size of discharge-pipe should be calculated for the particular conditions, allowing no greater velocity than 500 ft. per minute. The size of discharge-pipe is calculated in single-cylinder pumps from 250 to 400 ft. per minute. Greater velocity is permitted in the larger pipes.

In determining the proper size of pump for a steam-boiler, allowance must be made for a supply of water sufficient for the maximum capacity of the boiler when over driven, with an additional allowance for feeding water beyond this maximum capacity when the water level in the boiler becomes low. The average run of horizontal tubular boilers will evaporate from 2 to 3 lbs. of water per sq. ft. of heating-surface per hour, but may be driven up to 6 lbs. if the grate-surface is too large or the draught too great for economical working.

**Pump-Valves.** — A. F. Nagle (*Trans. A. S. M. E.*, x. 521) gives a number of designs with dimensions of double-beat or Cornish valves used in large pumping-engines, with a discussion of the theory of their proportions. Mr. Nagle says: There is one feature in which the Cornish valves are necessarily defective, namely, the lift must always be quite large, unless great power is sacrificed to reduce it. A small valve presents proportionately a larger surface of discharge with the same lift than a larger valve, so that whatever the total area of valve-seat opening, its full contents can be discharged with less lift through numerous small valves than with one large one. See also Mr. Nagle's paper on Pump Valves and Valve Areas, *Trans. A. S. M. E.*, 1909.

Henry R. Worthington was the first to use numerous small rubber valves in preference to the larger metal valves. These valves work well under all the conditions of a city pumping-engine. A volute spring is generally used to limit the rise of the valve.

In the Leavitt high-duty sewerage-engine at Boston (*Am. Machinist*, May 31, 1884), the valves are of rubber,  $\frac{3}{4}$  inch thick, the opening in valve-seat being  $13\frac{1}{2} \times 4\frac{1}{2}$  inches. The valves have iron face and back-plates, and form their own hinges.

The large pumping engines at the St. Louis water works have rubber valves  $3\frac{1}{2}$  in. outside diam. There are seven valve cages in each of the suction and discharge diaphragms, each cage having 28 valves. The aggregate free area of 196 valves is 7.76 sq. ft., the area of one plunger being 6.26 sq. ft. The suction and discharge pipes are each 36 in. diam., = 7.07 sq. ft. area. (Bull. No. 1609, Allis-Chalmers Co. Such liberal proportions of valves are found usually only in the highest grade of large high-duty engines. In small and medium sized pumps a valve area equal to one-third the plunger area is commonly used.)

The Worthington "High-Duty" Pumping Engine dispenses with a fly-wheel, and substitutes for it a pair of oscillating hydraulic cylinders, which receive part of the energy exerted by the steam during the first half of the stroke, and give it out in the latter half. For description see catalogue of H. R. Worthington, New York. A test of a triple expansion condensing engine of this type is reported in *Eng. News*, Nov. 29, 1904. Steam cylinders 13, 21, 34 ins.; plungers 30 in., stroke 25 in. Steam pressure, 124 lbs. Total head, 79 ft.; capacity, 14,267,000 gal. in 24 hrs. Duty per million B.T.U., 102,224,000 ft.-lbs.

The d'Auria Pumping Engine substitutes for a fly-wheel a compensating cylinder in line with the plunger, with a piston which pushes water to and fro through a pipe connecting the ends of the cylinder. It is built by the Builders' Iron Foundry, Providence, R. I.

A 72,000,000-gallon Pumping Engine at the Calf Pasture Station of the Boston Main Drainage Works is described in *Eng. News*, July 6, 1905. It has three cylinders,  $18\frac{1}{2}$ , 33 and  $52\frac{3}{4}$  ins., and two plungers, 60-in. diam.; stroke of all, 10 ft. The piston-rods of the two smaller cylinders connect to one end of a walking beam and the rod of the third cylinder to the other. Steam pressure 185 lbs. gauge; revolutions per min. 17; static head 37 to 43 ft. Suction valves 128; ports,  $4 \times 16\frac{1}{4}$  in.:



total port area 8576 sq. in. Delivery valves, 96; ports,  $4 \times 16\frac{3}{4}$  to  $20\frac{3}{4}$  in.; total port area 7215 sq. in. The valves are rectangular, rubber flaps, backed and faced with bronze and weighted with lead. They are set with their longest dimension horizontal, on ports which incline about  $45^\circ$  to the horizontal. At 17 r.p.m. the displacement is 72,000,000 gallons in 24 hours.

**The Screw Pumping Engine** of the Kinnickinick Flushing Tunnel, Milwaukee, has a capacity of 30,000 cubic feet per minute (= 323,000,000 gal. in 24 hrs.) at 55 r.p.m. The head is  $31\frac{1}{2}$  ft. The wheel 12.5 ft. diam., made of six blades, revolves in a casing set in the tunnel lining. A cone, 6 ft. diam. at the base, placed concentric with the wheel on the approach side diverts the water to the blades. A casing beyond the wheel contains stationary deflector blades which reduce the swirling motion of the water (Allis-Chalmers Co., Bulletin No. 1610). The two screw pumping engines of the Chicago sewerage system have wheels  $14\frac{3}{4}$  ft. diam., consisting of a hexagonal hub surmounted by six blades, and revolving in cylindrical casings 16 ft. long, allowing  $\frac{1}{4}$  in. clearance at the sides. The pumps are driven by vertical triple-expansion engines with cylinders 22, 38 and 62 in. diam., and 42 in. stroke.

**Finance of Pumping Engine Economy.**—A critical discussion of the results obtained by the Nordberg and other high-duty engines is printed in *Eng. News*, Sept. 27, 1900. It is shown that the practical question in most cases is not how great fuel economy can be reached, but how economical an engine it will pay to install, taking into consideration interest, depreciation, repairs, cost of labor and of fuel, etc. The following table is given, showing that with low cost of fuel and labor it does not pay to put in a very high duty engine. Accuracy is not claimed for the figures; they are given only to show the method of computation that should be used, and to show the influence of different factors on the final result.

**TABULAR STATEMENT OF TOTAL ANNUAL COST OF PUMPING WITH AN 800-H.P. ENGINE, AS INFLUENCED BY VARYING DUTY OF ENGINE, VARYING PRICE OF FUEL, AND VARYING TIME OF OPERATION.**

	Duty per million B.T.U.				
	50.	100.	120.	150.	180.
<b>First cost:</b>					
Engine.....	\$24,000	\$48,000	\$68,000	\$118,000	\$148,000
Engine, per H.P.....	30.00	60.00	85.00	147.50	185.00
Boilers, economizers.....	27,000	13,500	11,250	9,000	7,500
Engine and boilers.....	51,000	61,500	79,250	127,000	155,500
<b>Int. and depreciation:</b>					
On engine, at 6%.....	1,440	2,880	4,080	7,080	8,880
Boilers, 8%.....	2,160	1,080	900	720	600
Total.....	3,600	3,960	4,980	7,800	9,480
Labor per annum.....	6,022	6,022	7,655	9,307	10,220
<b>Fuel cost:</b>					
4,000 hrs. per yr.:					
\$3.00 per ton.....	17,280	8,640	7,200	5,760	4,800
4.00 per ton.....	23,040	11,520	9,600	7,680	6,400
5.00 per ton.....	28,800	14,400	12,400	9,600	8,000
6,000 hrs. per yr.:					
\$3.00 per ton.....	25,920	12,960	10,800	8,640	7,200
4.00 per ton.....	34,560	17,280	14,400	11,520	9,600
5.00 per ton.....	43,200	21,600	18,600	14,400	12,000
<b>Total annual cost:</b>					
4,000 hrs. per yr.:					
Coal, \$3 per ton.....	26,902	18,622	19,835	22,867	24,500
4 per ton.....	32,662	21,502	22,235	24,787	25,100
5 per ton.....	38,422	24,382	25,035	26,707	27,700
6,000 hrs. per yr.					
Coal, \$3 per ton.....	35,522	22,942	23,435	25,747	26,900
4 per ton.....	44,182	27,262	27,035	28,627	29,300
5 per ton.....	52,822	31,582	31,235	31,507	31,700

**Cost of Electric Current for Pumping 1000 Gallons per Minute  
100 ft. High.** (Theoretical H.P. with 100% efficiency =  
 $100,000 \div 3958.9 = 25.259$  H.P.)

Assume cost of current = 1 cent per K.W. hour delivered to the motor; efficiency of motor = 90%; mechanical efficiency of triplex pumps = 80%; of centrifugal pumps = 72%; combined efficiency, triplex pumps, 72%; centrifugal, 64.8%. 1 K.W. = 1.34 electrical H.P. on wire.

Triplex,  $1.34 \times 0.72 = 0.9648$  pump H.P.;  $\times 33,000 = 31,838$  ft.-lbs. per min.

Centrifugal,  $1.34 \times 0.648 = 0.86382$  pump H.P.;  $\times 33,000 = 28,654$  ft.-lbs. per min.

1000 gallons 100 ft. high = 833,400 ft.-lbs. per min.

Triplex,  $833,400 \div 31,838 = 26.1763$  K.W.  $\times 8760$  hours per year  $\times \$0.01 = \$2293.04$ .

Centrifugal,  $833,400 \div 28,655 = 29.0840$  K.W.  $\times 8760$  hours per year  $\times \$0.01 = \$2547.76$ .

For 100% efficiency,  $\$2293.04 \times 0.72 = \$1650.00$ . For any other efficiency, divide \$1650.00 by the efficiency. For any other cost per K.W. hour, in cents, multiply by that cost.

**Cost of Fuel per Year for Pumping 1,000 Gallons per Minute  
100 Ft. High by Steam Pumps.**

(1)	(2)		(3)	(4)	(5)	(6)	(7)
	100% Effy.	90%					
10.	198.	178.2	142.56	0.5846	0.42090	153.63	460.89
11.88	166.667	150.	120.	0.6945	0.50004	182.51	547.53
14.	141.433	127.87	101.83	0.8184	0.58926	215.08	645.24
14.256	138.889	125.	100.	0.8334	0.60005	219.02	657.06
15.	132.	118.8	95.04	0.8769	0.63125	230.44	691.32
16.	123.75	111.375	89.10	0.9354	0.67344	245.80	737.40
17.82	111.111	100.	80.	1.0417	0.75006	273.77	821.31
20.	99.	89.1	71.28	1.1692	0.84180	307.26	921.78
23.76	83.333	75.	60.	1.3890	1.00008	365.03	1095.09
30.	66.	59.4	47.52	1.7538	1.26270	460.89	1382.67
35.64	55.556	50.	40.	2.0835	1.50012	547.54	1642.62
40.	49.5	44.5	35.64	2.3384	1.68360	614.52	1843.56
47.52	41.667	37.5	30.	2.7780	2.09016	730.06	2190.18
50.	39.6	35.64	28.51	2.9230	2.10450	768.15	2304.45
a	b	c	d	e	f	g	h

(1) Lbs. steam per I.H.P. per hour.

(2) Duty million ft.-lbs. per 1000 lbs. steam, b, 100% effy., c, 90%.

(3) Duty per 100 lbs. coal, 90% effy., 8 lbs. steam per lb. coal.

(4) Lbs. coal per min. for 1000 gals., 100 ft. high.

(5) Tons, 2000 lbs. in 24 hours.

(6) Tons per year, 365 days.

(7) Cost of fuel per year at \$3.00 per ton.

Factors for calculation:  $b = 1980 \div a$ ;  $c = b \times 0.9$ ;  $d = c \times 0.8$ ;

$e = 8334 \div 100 d$ ;  $f = e \times 0.72$ ;  $g = f \times 365$ ;  $h = g \times 3$ .

For any other cost of coal per ton, multiply the figures in the last column by the ratio of that cost to \$3.00.

**Cost of Pumping 1000 Gallons per Minute 100 ft. High by  
Gas Engines.**

Assume a gas engine supplied by an anthracite gas producer using 1.5 lbs. of coal per brake H.P. hour, coal costing \$3.00 per ton of 2000 lbs.

Efficiency of triplex pump 80%, of centrifugal pump, 72%.

1000 gals. per min. 100 ft. high = 833,400 ft.-lbs. per min.  $\div 33,000 = 25.2545$  H.P.

Fuel cost per brake H.P. hour 1.5 lbs.  $\times 300$  cents  $\div 2000 = 0.225$  cent  $\times 8760$  hours per year = \$19.71 per H.P.  $\times 25.2545 = \$497.766$  for 100% efficiency.

For 80% effy., \$622.21; for 72% effy., \$691.34; or the same as the cost with a steam pumping engine of 95,000,000 foot-pounds duty per 100 lbs. of coal.

**Cost of Fuel for Electric Current.**

Based on 10 lbs. steam per I.H.P. hour, 8 lbs. steam per lb. coal, or 1.25 lbs. coal per I.H.P. per hour. (Electric line loss not included.)

Efficiency of engine 0.90, of generator 0.90, combined effy. 0.81.

I.H.P. = 0.746 K.W.,  $0.746 \times 0.81 = 0.6426$  K.W. on wire for 10 lbs. steam. Reciprocal = 16.5492 lbs. steam per K.W. hour. 8 lbs. steam per lb. coal = 2.06865 lbs. coal, at \$3.00 per ton of 2,000 lbs. = 0.3103 cents per K.W. hour.

Lbs. steam per I.H.P. hr. —

12            14            16            18            20            30            40

Fuel cost, cents per K.W. hr. —

0.3724    0.4344    0.4965    0.5585    0.6206    0.9309    1.2412

**CENTRIFUGAL PUMPS.**

**Theory of Centrifugal Pumps.** — Bulletin No. 173 of the Univ. of Wisconsin, 1907, contains an investigation by C. B. Stewart of a 6-in. centrifugal pump which gave a maximum efficiency, under the best conditions of load, of only 32%, together with a discussion of the general theory of M. Combe, 1840, which has been followed by Weisbach, Rankine, and Unwin. Mr. Stewart says that the theory of the centrifugal pump, at the times of these writers, seemed practically settled, but it was found later that the pump did not follow the theoretical laws derived, and the subject is still open for investigation. The theoretical head developed by the impeller can be stated for the condition of impending delivery, but as soon as flow begins the ordinary theory does not seem to apply. Experiment shows that the main difficulty to be overcome in order to secure high efficiency with the centrifugal pump is in providing some means of transforming the portion of the energy which exists in the kinetic form, at the outlet of the impeller, to the pressure form, or of reducing the loss of head in the pump casing to a minimum. The theoretical head for impending delivery is  $V^2 \div g$ , while experiment shows that the maximum actual head approaches  $V^2 \div 2g$  as a limit. As the flow commences each pound of water discharged will possess the kinetic energy  $V^2 \div 2g$  in addition to its pressure energy. To secure high efficiency some means must be found of utilizing this kinetic energy. The use of a free vortex or whirlpool, surrounding the impeller, and this surrounded by a suitable spiral discharge chamber, is practically accepted as one means of utilizing the energy of the velocity head. Guide vanes surrounding the impeller also provide a means of changing velocity head to pressure head, but the comparative advantage of these two means cannot be stated until more experimental data are obtained.

The catalogue of the Alberger Pump Co., 1908, contains the following:

It was not until the year 1901 that the centrifugal pump was shown to be nothing more or less than a water turbine reversed, and when designed on similar lines was capable of dealing with heads as great, and with efficiencies as good, as could be obtained with the turbines themselves. Since this date great progress has been made in both the theory and design, until now it is quite possible to build a pump for any reasonable conditions and to accurately estimate the efficiency and other characteristics to be expected during actual operation.

The mechanical power delivered to the shaft of a centrifugal pump by the prime mover is transmitted to the water by means of a series of radial vanes mounted together to form a single member called the impeller, and revolved by the shaft. The water is led to the inner ends of the impeller vanes, which gently pick it up and with a rapidly accelerating motion cause it to flow radially between them so that upon reaching the outer circumference of the impeller the water, owing to the velocity and pressure acquired, has absorbed all the power transmitted to the pump shaft. The problem to be solved in impeller design is to obtain the required velocity and pressure with the minimum loss in shock and friction. Since the energy of the water on leaving the pump is required to be mostly in the form of pressure, the next problem is to transform into pressure the kinetic energy of the water due to its velocity on leaving the impeller and furthermore to accomplish this with the least possible loss.

The next consideration in impeller design is the proportions of the vanes and the water passages, and to properly solve this problem an



extensive use of intricate mathematical formulæ is necessary in addition to a wide knowledge of the practical side of the question. It is possible to obtain the same results as to capacity and head with practically an infinite number of different shapes, each of which gives a different efficiency as well as other varied characteristics. The change from velocity to pressure is accomplished by slowing down the speed of the water in an annular diffusion space extending from the impeller to the volute casing itself and so designed that there is the least loss from eddies or shock. It is necessary that this change shall take place gradually and uniformly, as otherwise most of the velocity would be consumed in producing eddies. With a proper design of the diffusion space and volute it is possible to transform practically the whole of the velocity into pressure so that the loss from this source may be very small.

It is necessary also to furnish a uniform supply of water to all parts of the inlet or suction opening of the impeller, for unless all the impeller vanes receive the same quantity of water at their inner edges, they cannot deliver an equal quantity at their outer edges, and this would seriously interfere with the continuity of the flow of water and the successful operation of the pump.

**Relation of the Peripheral Speed to the Head.**—For constant speed the discharge of a centrifugal pump for any lift varies with the square root of the difference between the actual lift and the hydrostatic head created by the pump without discharge. If any centrifugal pump connected to a source of supply and to a discharge pipe of considerable height is put in revolution, it will be found that it is necessary to maintain a certain peripheral runner speed to hold the water 1 ft. high without discharge, and that for any other height the requisite speed will be very nearly proportional to the square root of the height.

Experiments prove that the peripheral speed in ft. per min. necessary to lift water to a given height with vanes of different forms is approximately as follows:  $a$ ,  $481 \sqrt{h}$ ;  $b$ ,  $554 \sqrt{h}$ ;  $c$ ,  $610 \sqrt{h}$ ;  $d$ ,  $780 \sqrt{h}$ ;  $e$ ,  $394 \sqrt{h}$ .  $a$  is a straight radial vane,  $b$  is a straight vane bent backward,  $c$  is a curved vane, its extremity making an angle of  $27^\circ$  with a tangent to the impeller,  $d$  is a curved vane with an angle of  $18^\circ$ ,  $e$  is a vane curved in the reverse direction so that outer end is radial.

Applying the above formula, speed ft. per min. = coeff.  $\times \sqrt{h}$ , to the design of Mr. Clifford, gives  $60 \times 75.05 = C \times \sqrt{85}$ , whence  $C = 488$ . The vane angle was  $12^\circ$ . It is evident that the value of  $C$  depends on other things than the shape or angle of the vanes, such as smoothness of the vanes and other surfaces, shape and area of the diffusion vanes, and resistance due to eddies in the pump passages.

The coefficient varies with the shape of the vanes; this means that different speeds are necessary to hold water to the same heights with these different forms of vanes, and for any constant speed or lift there must be a form of vane more suitable than any other. It would seem at first glance that the runner which creates a given hydrostatic head with the least peripheral velocity must be the most efficient, but practically it is apparent from tests that the curvature of the vanes can be designed to suit the speed and lift without materially lowering the efficiency. (L. A. Hicks, *Eng. News*, Aug. 9, 1900.)

The quotient of the radial velocity of flow in a centrifugal pump divided by the peripheral velocity is a constant  $C$ . By plotting efficiency curves for various speeds in the discharge-efficiency diagram, it is found that the points of maximum efficiency of the various curves lie nearly in a straight line, hence the constant  $C$  varies but little with the speed. Examination of the data from a large number of pumps of various designs shows that high speeds are consistent with good efficiency, and that the best values for  $C$  lie between the limits of 0.12 and 0.15. There is no advantage in the use of excessively wide impellers.—(N. W. Akimoff, *Jour. Franklin Institute*, May, 1911.)

**Design of a Four-stage Turbine Pump.**—C. W. Clifford, in *Am. Mach.*, Oct. 17, 1907, describes the design of a four-stage pump of a capacity of 2300 gallons per minute = 5.124 cu. ft. per sec. Following is an abstract of the method adopted. The total head was 1000 ft. Three sets of four-stage pumps were used at elevations of 16.332, and 666 ft., the discharge of the first being the suction of the second, and so on.

The speed of the motor shaft is 850 r.p.m. This gives, for the diameter of the impeller,  $d = 12 \times 60 \times 75.05 \div 850 \pi = 20.24$  in. Circumference  $C = 63.6$  in;  $h =$  head for each impeller, in ft.

$V =$  peripheral speed  $= 1.015 \sqrt{2gh} = 75.05$  ft. per sec., 1.015 being an assumed coefficient. The velocity  $V$  is divided into two parts by the formula  $V_1 = V - V_2$ ;  $V_2 = 2gh \div 2V$ ; whence  $V_1 = 38.65$  ft. per sec. This is the tangential component of the actual velocity of the water as it leaves the vane of the impeller. The radial component, or the radial velocity, was taken approximately at 8 ft. per sec.;  $8 \div 38.65 = \text{tang. of } 11^\circ 42'$ , the calculated angle between the vane and a tangent at the periphery. Taking this at  $12^\circ$  gives  $\text{tang. } 12^\circ \times 38.65 = 8.215$  ft. per sec.  $=$  radial velocity  $V$ . The outflow area at the impeller then is  $5.124 \times 144 \div (8.215 \times 0.85) = 105$  sq. in.; the 0.85 is an allowance for contraction of area in the impeller. The thickness of the vane measured on the periphery is approximately  $1\frac{3}{4}$  in.; taking this into account the width of the impeller was made  $17\frac{7}{8}$  in. [ $105 \div (63.6 - 6 \times 1\frac{3}{4}) = 1.98$  in.]. The vanes were then plotted as shown in Fig. 156, keeping the distance between them nearly constant and of uniform section. Care was taken to increase the velocity as gradually as possible.

The suction velocity was 9.37 ft. per sec., the diam. of the opening being 10 in. This was increased to 11 ft. per sec. at the opening of the impeller, from which, after deducting the area of the shaft, the diameter,  $d$ , of the impeller inlet was found. Three long and three short vanes were used to reduce the shock.

The diffusive vanes, Fig. 157, were then designed, the object being to change the direction of the water to a radial one, and to reduce the velocity gradually to 2 ft. per sec. at the discharge through the ports.

Fig. 158 shows a cross-section of the pump. The pumps were thoroughly tested, and the following figures are derived from a mean curve of the results:

Gals. per min..	500	1000	1500	2000	2200	2400	2500	3000	3500
Efficiency, %	30	51	68	78	79	78	76	61	31

**A Combination Single-stage and Two-stage Pump,** for low and high heads, designed by Rateau, is described by J. B. Sperry in *Power*, July 13, 1909. It has two runners, one carried on the main driving-shaft, and the other on a hollow shaft, driven from the main shaft by a clutch. It has two discharge pipes, either one of which may be closed. When the hollow shaft is uncoupled, one runner only is used, and the pump is then a single-stage pump for low heads. When the shafts are coupled, the water passes through both runners, and may then be delivered against a high head.

**Tests of De Laval Centrifugal Pumps.**—The tables on pp. 800, 801 contain a condensed record of tests of three De Laval pumps made by Prof. J. E. Denton and the author in April, 1904. Two of the pumps were driven by De Laval steam turbines, and the other one by an electric motor. In the two-stage pump the small wheel was coupled direct to the high-speed shaft of the turbine, running at about 20,500 r.p.m., and the large wheel was coupled to the low-speed shaft, which is driven by the first through gears of a ratio of 1 to 10. The water delivery and the duty were computed from weir measurements, Francis's formula being used, and this was checked by calibration of the weir at different heads by a tank, the error of the formula for the weir used being less than 1%. Pitot tube measurements of the water delivered through a nozzle were also made.

One inch below the center of the nozzle was located one end of a thin half-inch brass tube, tapered so as to make an orifice of  $\frac{3}{32}$  inch diameter. The other end of this tube was connected to a vertical glass tube, fastened to the wall of the testing room, graduated in inches over a height of about 30 ft. The stream of water issuing from the nozzle impinged upon the orifice of the brass tube, and thereby maintained a height of water in the glass tube. This height afforded a "Pitot Tube Basis" of measurement of the quantity of water flowing, the reliability of which was tested by the flow as determined from the weir. The Pitot tube gave the same result as the weir from the formula  $Q_1 = C \times \text{Area of Nozzle} \times \sqrt{2gh}$  with a value of  $C$  varying only between 0.953 and 0.977 for the large nozzle, and between 0.942 and 0.960 for the small nozzle.

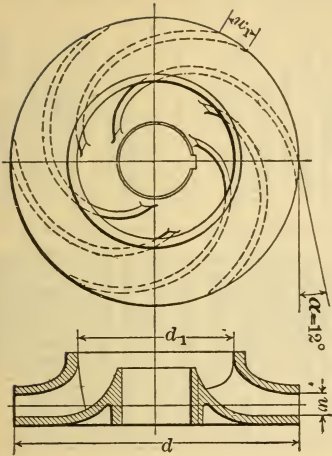

FIG. 156.



FIG. 157.

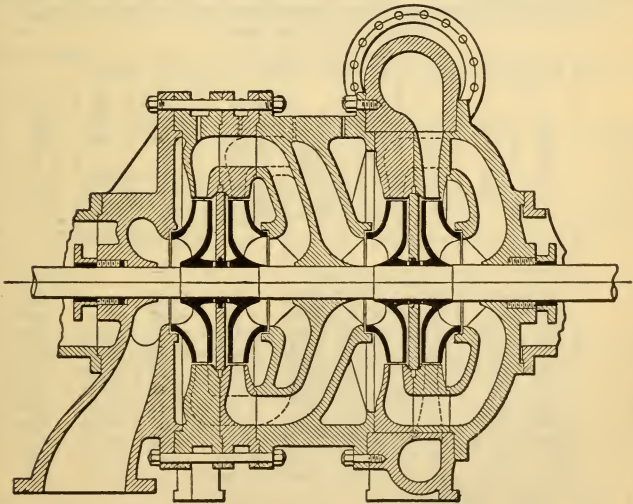

FIG. 158.



TEST OF STEAM TURBINE CENTRIFUGAL PUMP, RATED AT 1700 GAL.  
PER MIN., 100 FT. HEAD.

No. of Test.	Steam Press. at the Governor Valve. Lbs. per Sq. In.		Inches Vacuum.	Revolutions per Minute.	*Brake Horse-Power Calculated.	*Steam per Brake Horse-power.	Duty. — Millions of Foot-Lbs. per 1000 Lbs. of Steam.	Water Horse-Power.	Total Head, including Suction, Feet.	Water Pumped, Gals. per Min.	Efficiency of Pump.
	Above.	Below.									
6	190	126	251/4	1,547	47.7	25.45	37.43	22.95	45.97	1,978	0.481
10	190	148	251/2	1,536	56.65	24.42	50.44	34.95	70.75	1,958	0.617
1	188	155.2	25	1,553	59.6	24.06	61.50	44.54	94.9	1,860	0.747
2	188	153.5	251/4	1,547	58.9	24.21	61.86	44.55	100.37	1,759	0.756
3	188	150.7	251/4	1,540	57.7	24.33	61.47	43.59	106.94	1,615	0.755
4	188	143.5	251/2	1,549	54.8	24.53	60.00	40.72	115.46	1,398	0.743
5	188	161	253/8	1,540	47.5	24.5	54.47	31.80	125.85	1,001	0.676
6A	189.5	170	251/2	1,565	24.9	.....	Shut-off T.	142.15	.....	.....	.....
†7	189	169.5	.....	1,537	.....	.....	45.15	43.85	95.14	1,826	.....
†8	189	169	.....	1,535	.....	.....	45.12	43.82	99.05	1,753	.....
†9	189	169.7	.....	1,538	.....	.....	44.62	42.93	104.42	1,629	.....

\* The brake H.P. and the steam per B.H.P. hour were calculated by a formula derived from Prony brake tests of the turbine.

† Non-condensing.

TEST OF ELECTRIC MOTOR CENTRIFUGAL PUMP. DIAM. OF PUMP WHEEL  
8<sup>9</sup>/<sub>32</sub> IN. RATED AT 1200 GAL. PER MIN. — 45 FT. HEAD.  
2000 REVS. PER MIN.

No. of Test.	Volts.	Amperes.	E.H.P.	* Brake Horse-Power.	Revolutions per Minute.	Cubic Feet of Water per Sec. by Weir.	Water Horse-Power.	Total Head, Feet.	Water Pumped, Gals. per Min.	Efficiency of Pump.
1.....	242.5	55.2	17.94	15.07	2,006	3.158	10.25	28.52	1,417	0.680
2.....	242.3	54.8	17.80	14.94	1,996	3.126	10.67	30.12	1,403	0.714
3.....	242	59	19.14	16.22	1,996	2.885	11.80	36.1	1,295	0.728
4.....	242	62.4	20.24	17.27	2,005	2.826	12.18	38.05	1,268	0.706†
5.....	241.8	62.9	20.39	17.41	2,000	2.525	13.06	45.66	1,133	0.750
6.....	240.8	66	21.30	18.28	2,005	2.504	13.40	47.25	1,124	0.733†
7.....	241.4	64	20.71	17.71	2,003	2.197	13.12	52.7	986	0.742
8.....	239.7	66.3	21.30	18.28	1,997	2.179	13.15	53.28	978	0.720†
9.....	240.9	63.2	20.41	17.43	2,007	1.735	11.42	58.10	779	0.665†
10.....	242	62	20.11	17.14	2,003	1.760	11.71	58.76	790	0.683
11.....	248	34	11.30	8.74	2,040	Shut-off	.....	68.39	.....	.....

\* Brake H.P. calculated from a formula derived from a brake test of the motor.

† Tests marked † were made with the pump suction throttled so as to make the suction equal to about 22 ft. of water column. In the other tests the suction was from 5.6 to 10.9 ft.

TEST OF STEAM TURBINE TWO-STAGE CENTRIFUGAL PUMP. RATED AT 250 GALS. PER MIN. 700 FT. HEAD. LARGE PUMP WHEEL, 2050 R.P.M.; SMALL WHEEL, 20,500 R.P.M.

Steam Press. at the Governor Valve. Lbs. per Sq. In.		Pressure between Pumps. Lbs. Sq. In.	Vacuum, In.	Steam Consumption, Lbs.	Revolutions per Minute.	Cu. Ft. of Water per Sec. by Weir.	Total Head. Feet.	Water Horse-Power.	Water Quantity, Gals. per Min. by Weir.	Duty, — Millions of Ft.-Lbs. per 1000 Lbs. of Steam.	Lbs. of Steam per W.H.P. per Hour.
Above.	Below.										
186	120.7	28.1	25.25	341	2,104	0.830	135.76	12.83	373	18.63	106.2
175	138.3	27.5	24.4	...	2,092	0.799	193.85	17.54	359	...	...
181	162.3	27.05	25.5	385	2,074	0.790	288	25.78	354	28.73	68.9
178	173.7	26.2	25.5	316	2,056	0.775	358.78	31.50	347	32.9	60.2
180	180.3	26	25.3	326	2,027	0.750	420.5	35.60	336	36.00	54.9
181	182	25.3	25.25	325	2,001	0.731	494.35	40.92	328	41.55	47.7
180	182	24.9	25.35	...	1,962	0.697	585.06	46.19	312	...	...
186	188.3	25.5	26.3	331	2,014	0.664	632.6	47.58	299	47.43	41.77
185	185	30	25.3	331	2,012	0.558	756.38	47.81	251	47.67	41.5
185	184	29	26.5	325	2,029	0.544	781.4	48.15	244	48.88	40.50

**A Test of a Lea-Deagan Two-Stage Pump**, by Prof. J. E. Denton, is reported in *Eng. Rec.*, Sept. 29, 1906. The pump had a 10-in. suction and discharge line, and impellers 24 in. diam., each with 8 blades. The following table shows the principal results, as taken from plotted curves of the tests. The pump was designed to give equal efficiency at different speeds.

Gal. per min.	400	800	1200	1600	2000	2400	2800	3000	3200	3400	3600	3800
Efficiency.												
400 r.p.m.	42	61	69	75	77	77	70	...	...	...	...	...
500 "	39	56	65	71	75	77	77.6	77	74	70	...	...
600 "	35	50	62	68	71	74	76	77	78	78	76	54
Head.												
400 r.p.m.	55	55	53	51	47	42	34	...	...	...	...	...
500 "	63	86	84	82	78	73	67	63	58	51	...	...
600 "	126	127	125	122	118	115	107	104	101	97	87	55

The following results were obtained under conditions of maximum efficiency:

400 r.p.m.	77.7% effy.	2296 gals. per min.	43.6 ft. lift
500 "	77.6	2794 "	67.4 "
600 "	77.97	3235 "	100.7 "

**A High-Duty Centrifugal Pump.**—A 45,000,000 gal. centrifugal pump at the Deer Island sewage pumping station, Boston, Mass., was tested in 1896 and showed a duty of 95,867,476 ft.-lbs., based on coal fired to the boilers. — (Allis-Chalmers Co., Bulletin No. 1062.)

**Rotary Pumps.**—Pumps with two parallel geared shafts carrying vanes or impellers which mesh with each other, and other forms of positive driven apparatus, in which the water is pushed at a moderate velocity, instead of being rotated at a high velocity as in centrifugal pumps, are known as rotary pumps. They have an advantage over reciprocating pumps in being valveless, and over centrifugal pumps in working under variable heads. They are usually not economical, but when carefully designed with the impellers of the correct cycloidal shape, like those used in positive rotary blowers, they give a high efficiency. They are especially useful in handling large volumes of water at heads from 10 to 50 feet and also as vacuum pumps for condensers.

They are not well adapted for lifting small quantities of water at high pressure.

By calibrating the discharge per revolution and attaching a revolution counter a rotary pump may be used as a water meter.

An improvement in rotary pumps is to drive the two impellers by a cross-compound engine, the two cylinders of which are so set that the high-pressure piston drives one impeller and the low-pressure piston the other. In this arrangement the transmission of power from one impeller shaft to the other through gearing is avoided. (Connersville Blower Co., 1915.)

**Tests of Centrifugal and Rotary Pumps.** (W. B. Gregory, *Bull.* 183, U. S. Dept. of Agriculture, 1907.)—These pumps are used for irrigation and drainage in Louisiana. A few records of small pumps, giving very low efficiencies, are omitted. Oil was used as fuel in the boilers, except in the pump of the New Orleans drainage station No. 7 (figures in the last column), which was driven by a gas-engine.

Actual lift.....	15.5	16.2	11.2	30.2	9.5	23.7	31.7	6.8	31.6	13.4
Disch. cu. ft. per sec...	72.6	157.0	116.0	93.2	71.4	68.7	85.6	130.5	152.9	30.5
Water horse-power. ...	127.5	287.4	147.1	318.0	76.5	222.8	306.8	98.8	547.9	46.2
I.H.P.....	155.6	671.2	229.8	648.0	137.7	503.9	452.3	193.6	657.7	90.6
Effy., engine, gearing and pumps. ....	81.7	42.9	64.2	49.0	55.6	44.3	67.9	51.0	83.3	51.0
Duty, per 1000 lbs. stea.	72.1	34.3	40.7	33.8	.....	33.9	78.2	31.4	75.4	....
Duty, per million B.T.U. in fuel.....	37.8	18.3	20.7	24.2	22.1	17.3	51.1	16.7	50.1	82.4
Therm. effy. from stea.	8.16	4.23	4.68	4.16	.....	4.09	9.70	3.93	9.61	....
Kind of engine, and pump.....	a, f	b, g	b, g	b, g	c, g	b, g	a, g	d, g	a, g	e, g

*a*, Tandem compound condensing Corliss; *b*, Simple condensing Corliss; *c*, Simple non-condensing Corliss; *d*, Triple-expansion condensing, vertical; *e*, Three-cylinder vertical gas-engine, with gas-producer, 0.85 lb. coal per I.H.P. per hour; *f*, Rotary pump; *g*, Cycloidal rotary.

The relatively low duty per million B.T.U. is due to the low efficiency of the boilers. The test whose figures are given in the next to the last column is reported by Prof. Gregory in *Trans. A. S. M. E.*, to vol. xxviii.

### DUTY TRIALS OF PUMPING-ENGINES.

A committee of the *A. S. M. E.* (*Trans.*, xii. 530) reported in 1891 on a standard method of conducting duty trials. Instead of the old unit of duty of foot-pounds of work per 100 lbs. of coal used, the committee recommend a new unit, foot-pounds of work per million heat-units furnished by the boiler. The variations in quantity of coal make the old standard unfit as a basis of duty ratings. The new unit is the precise equivalent of 100 lbs. of coal in cases where each pound of coal imparts 10,000 heat-units to the water in the boiler, or where the evaporation is  $10,000 \div 970.4 = 10.305$  lbs. of water from and at 212° per pound of fuel. This evaporative result is readily obtained from all grades of Cumberland or other semi-bituminous coal used in horizontal return tubular boilers, and, in many cases, from the best grades of anthracite coal.

The committee on Power Tests (1915) reaffirmed the new unit, defining it as follows:

The duty per million heat-units is found by dividing the number of foot-pounds of work done during the trial by the total number of heat-units consumed, and multiplying the quotient by 1,000,000. The amount of work is found in the case of reciprocating pumps by multiplying the net area of the plunger in sq. in., the total head expressed in pounds per square inch\* by the length of the stroke in feet, and the total number of single strokes during the trial; finally correcting

\* The total head is determined by adding together the pressure shown by the gage on the force main, the vacuum shown by the gage on the suction main, and the vertical distance between the center of the force-main gage and the point where the suction-gage pipe connects to the suction main, all expressed in the same units (pounds per square inch or foot). A pet-cock should be attached to the gage pipe



for the percentage of leakage of the pump. In cases where the water delivered is determined by weir or other measurement, the work done is found by multiplying the weight of water discharged during the trial by the total head in feet.

The water horse-power of a pump is found by dividing the number of foot-pounds of work done per minute by 33,000.

**Capacity.**—The capacity in gallons per 24 hours for reciprocating pumps in cases where the water delivered is not measured, is found by multiplying the net area of the plunger in square inches by the length of the stroke in feet (in direct-connected engines the average length of stroke); then by the number of single strokes per minute; and the product of these three by the constant 74.8; finally correcting for the percentage of leakage of the pump.

**Leakage of Pump.**—The percentage of leakage is the percentage borne by the quantity of leakage, found on the leakage trial, to the quantity of water discharged on the duty run determined from plunger displacement.

**Leakage Test of Pump.**—The leakage of an inside plunger (the only type which requires testing) is most satisfactorily determined by making the test with the cylinder-head removed. A wide board or plank may be temporarily bolted to the lower part of the end of the cylinder, so as to hold back the water in the manner of a dam, and an opening made in the temporary head thus provided for the reception of an overflow-pipe. The plunger is blocked at some intermediate point in the stroke (or, if this position is not practicable, at the end of the stroke), and the water from the force main is admitted at full pressure behind it. The leakage escapes through the overflow-pipe, and it is collected in barrels and measured. The test should be made, if possible, with the plunger in various positions.

In the case of a pump so planned that it is difficult to remove the cylinder-head, it may be desirable to take the leakage from one of the openings which are provided for the inspection of the suction-valves, the head being allowed to remain in place.

It is assumed that there is a practical absence of valve leakage. Examination for such leakage should be made, and if it occurs, and it is found to be due to disordered valves, it should be remedied before making the plunger test. Leakage of the discharge valves will be shown by water passing down into the empty cylinder at either end when they are under pressure. Leakage of the suction-valves will be shown by the disappearance of water which covers them.

If valve leakage is found which cannot be remedied the quantity of water thus lost should also be tested. One method is to measure the amount of water required to maintain a certain pressure in the pump cylinder when this is introduced through a pipe temporarily erected, no water being allowed to enter through the discharge valves of the pump.

**Friction.**—The percentage of total friction in a reciprocating pump is the percentage of the friction horse-power to the indicated horse-power of the steam cylinders.

**Data and Results.**—The data and results should be reported in accordance with the form given herewith, adding lines for data not

---

below each gage cock, and opened occasionally so as to free the pipe of air in the case of the force-main gage and of water in the case of the suction gage. If the suction main is under a pressure instead of a vacuum the suction gage should be attached at such a level that the connecting pipe may be filled with water when the pet-cock is opened, in which case the correction for difference in elevation of gages is the vertical distance between the centers of the gages, and the reading of the suction gage is to be subtracted from that of the force-main gage.

If the water is drawn from an open well beneath the pump, the total head is that shown by the force-main gage corrected for the elevation of the center of the gage above the level of water in the pump well.

If there is a material difference in velocity of the water at the points where the two gages are attached, a correction should be made for the corresponding difference in "velocity-head."

provided for, or omitting those not required, as may conform to the object in view.

In the case of a pumping engine of the reciprocating class for which a record of the complete performance is desired, the additional engine data and results given in the Steam Engine Code may supplement those here given.

## DATA AND RESULTS OF STEAM PUMPING MACHINERY TEST.

Code of 1915.

1. Test of . . . . . pump located at . . . . .
- To determine . . . . .
- Test conducted by . . . . .

### DIMENSIONS, ETC.

2. Type of machinery . . . . .
3. Rated capacity in gallons per 24 hrs. . . . . gals.
4. Size of engine or turbine . . . . .
5. Size of pump . . . . .
6. Auxiliaries (steam or electric driven) . . . . .
7. Date . . . . .
8. Duration . . . . . hrs.

### AVERAGE PRESSURES AND TEMPERATURES.

9. Pressure in steam pipe near throttle by gage . . . . . lbs.
10. Vacuum in condenser . . . . . ins.
11. Temperature of steam, if superheated, at throttle . . . . . degs.
12. Temperature corresponding to pressure in exhaust pipe near engine or turbine . . . . . degs.
13. Pressure in force main by gage . . . . . lbs.
14. Vacuum or pressure in suction main by gage . . . . . ins. or lbs.
- (a) Correction for difference in elevation of the two gages . . . . . lbs.
15. Total head expressed in lbs. perssure per sq. in. . . . . lbs.
- (a) Total head expressed in feet . . . . . ft.

### QUALITY OF STEAM.

16. Percentage of moisture in steam, degrees superheating, % or degs.

### TOTAL QUANTITIES.

17. Total water fed to boilers . . . . . lbs.
18. Total condensed steam from surface condenser (corrected for condenser leakage) . . . . . lbs.
19. Total dry steam consumed (Item 19 or 20 less moisture in steam) . . . . . lbs.
20. Total gals. of water discharged, by measurement . . . . . gals.
- (a) Total gals. of water discharged, by plunger displacement, uncorrected . . . . . gals.
- (b) Percentage of slip  $\left( \frac{\text{Item } 20a - \text{Item } 20}{\text{Item } 20a} \right) \times 100$  . . . . . per cent.
- (c) Leakage of pump . . . . . gals.
- (d) Total gals. of water discharged, by calculation from plunger displacement, corrected for leakage . . . . . gals.
- (e) Total weight of water discharged, as measured . . . . . lbs.
- (f) Total weight of water discharged, by calculation from plunger displacement, corrected for leakage . . . . . lbs.

### HOURLY QUANTITIES.

21. Total water fed to boilers or drawn from surface condenser per hr. . . . . lbs.
22. Total dry steam consumed for all purposes per hour, (Item 19 ÷ Item 8) . . . . . lbs.

23. Steam consumed per hour for all purposes foreign to main engine..... lbs.  
 24. Dry steam consumed by engine or turbine per hour (Item 23 - Item 24)..... lbs.  
 25. Weight of water discharged per hour, by measurement.. lbs.  
 (a) Weight of water discharged per hour, calculated from plunger displacement, corrected..... lbs.

## HOURLY HEAT DATA.

26. Heat-units consumed by engine or turbine per hour (Item 24  $\times$  total heat of one lb. of steam above exhaust temperature of Item 12)..... B.T.U.

## INDICATOR DIAGRAMS.

27. Mean effective pressure, each steam cylinder..... lbs. per sq. in.  
 (a) Mean effective pressure, each water cylinder. lbs. per sq. in.

## SPEED AND STROKE.

28. Revolutions per minute..... R.P.M.  
 (a) Number of single strokes per minute..... strokes  
 (b) Average length of stroke..... feet.

## POWER.

29. Indicated horse-power developed..... I.H.P.  
 30. Water horse-power..... H.P.  
 31. Friction horse-power (Item 29 - Item 30)..... H.P.  
 32. Percentage of I.H.P. lost in friction..... per cent.

## CAPACITY.

33. Gallons of water pumped in 24 hrs., as measured..... gals.  
 (a) Gals. of water pumped in 24 hrs., calculated from plunger displacement, corrected..... gals.  
 (b) Gals. of water pumped per minute, as measured.. gals.  
 (c) Gals. of water pumped per minute, calculated from plunger displacement, corrected..... gals.

## ECONOMY RESULTS.

34. Heat-units consumed per I.H.P.-hr..... B.T.U.

## EFFICIENCY RESULTS.

35. Thermal efficiency referred to I.H.P. ( $2546.5 \div$  Item 34)  $\times 100$ ..... per cent.

## DUTY.

36. Duty per 1,000,000 heat-units..... ft.-lbs.

## WORK DONE PER HEAT-UNIT.

37. Ft.-lbs. of work per B.T.U. ( $1,980,000 \div$  Item 34)..... ft.-lbs.

**The Nordberg Pumping Engine at Wildwood, Pa.** — *Eng. News*, May 4, 1899, Aug. 23, 1900, *Trans. A. S. M. E.*, 1899. The peculiar feature of this engine is the method used in heating the feed-water. The engine is quadruple expansion, with four cylinders and three receivers. There are five feed-water heaters in series, *a, b, c, d, e*. The water is taken from the hot-well and passed in succession through *a* which is heated by the exhaust steam on its passage to the condenser; *b* receives its heat from the fourth cylinder, and *c, d* and *e* respectively from the third, second and first receivers. An approach is made to the requirement of the Carnot thermodynamic cycle, *i.e.*, that heat entering the system should be entered at the highest temperature; in this case the water receives the heat from the receivers at gradually increasing temperatures. The temperatures of the water leaving the several heaters were, on the test, 105°, 136°, 193°, 260°, and 311° F. The economy obtained with this engine was the highest on record at the date (1900) *viz.*, 162,948,824 ft. lbs. per million B.T.U., and it has not yet been exceeded (1909).



## Notable High-duty Pumping Engine Records.

	(1) 1899	(2) 1900	(3) 1900	(4) 1901	(5) 1906
Date of test.....	1899	1900	1900	1901	1906
Locality.....	Wildwood, Pa.	St. Louis (10).	Boston, Chest- nut Hill	Boston, Spot Pond.	St. Louis (3) Bissell's Point.
Capacity, mil. gal., 24 hrs...	6	15	30	30	20
Diam. of steam cylinders, in.	19.5, 29, 49.5	34, 62, 92	30, 56, 87	22, 41.5, 62	34, 62, 94
Stroke, in.....	57.5 × 42	× 42	× 66	× 60	72
No. and diam. of plungers...	(2) 143/4	(3) 29 1/2	(3) 42	(3) 30.5	(3) 33 7/8
Piston speed, ft. per min....	256	197	195	244	198
Total head, ft.....	504	292	140	125	238
Steam pressure.....	200	126	185	151	146
Indicated Horse-power.....	712	801	801	464	859
Friction, %.....	6.95	3.16	6.71	3.47	2.27
Mechanical efficiency, %.....	93.05	96.84	93.29	96.53	97.73
Dry steam per I.H.P. hr....	12.26, 11.4	10.68	10.34	11.09	.....
B.T.U. per I.H.P. per min...	186*	202	196	203	202.8
Duty, B.T.U. basis.....	162.9* 147.5†	158.07	156.8	156.59	158.85
Duty per 1000 lbs. steam....	150.2*	179.45	178.49	172.40	181.30
Thermal efficiency, %.....	22.81	21.00	21.63	20.84	20.92

\* With reheaters.

† Without reheaters.

(1), (2). From *Eng. News*, Sept. 27, 1900. (3) Do. Aug. 23, 1900. (4) Do. Nov. 4, 1901. (5) Allis-Chalmers Co., Bulletin No. 1609. The Wildwood engine has double-acting plungers.

The coal consumption of the Chestnut Hill engine was 1.062 lbs. per I.H.P. per hour, the lowest figure on record at that date, 1901.

## VACUUM PUMPS.

**The Pulsometer.** — In the pulsometer the water is raised by suction into the pump-chamber by the condensation of steam within it, and is then forced into the delivery-pipe by the pressure of a new quantity of steam on the surface of the water. Two chambers are used which work alternately, one raising while the other is discharging.

*Test of a Pulsometer.* — A test of a pulsometer is described by De Volson Wood in *Trans. A. S. M. E.*, xiii. It had a 3 1/2-inch suction-pipe, stood 40 in. high, and weighed 695 lbs.

The steam-pipe was 1 inch in diameter. A throttle was placed about 2 feet from the pump, and pressure gauges placed on both sides of the throttle, and a mercury well and thermometer placed beyond the throttle. The wire drawing due to throttling caused superheating.

The pounds of steam used were computed from the increase of the temperature of the water in passing through the pump.

Pounds of steam × loss of heat = lbs. of water sucked in × increase of temp.

The loss of heat in a pound of steam is the total heat in a pound of saturated steam as found from "steam tables" for the given pressure, plus the heat of superheating, minus the temperature of the discharged water; or

$$\text{Pounds of steam} = \frac{\text{lbs. water} \times \text{increase of temp.}}{H - 0.48 t - T}$$

The results for the four tests are given in the table on p. 807.

Of the two tests having the highest lift (54.05 ft.), that was more efficient which had the smaller suction (12.26 ft.), and this was also the most efficient of the four tests. But, on the other hand, the other two tests having the same lift (29.9 ft.), that was the more efficient which had the greater suction (19.67), so that no law in this regard was established. The pressures used, 19, 30, 43.8, 26.1, follow the order of magnitude of the total heads, but are not proportional thereto. No attempt was made to determine what pressure would give the best efficiency for any par-

## Test of a Pulsometer.

Data and Results.	1	2	3	4
Strokes per minute.....	71	60	57	64
Steam pressure in pipe before throttling.....	114	110	127	104.3
Steam pressure after throttling..	19	30	43.8	26.1
Steam temp. after throttling, °F..	270.4	277	309.0	270.1
Steam superheating, °F.....	3.1	3.4	17.4	1.4
Steam used, lbs.....	1617	931	1518	1019.9
Water pumped, lbs.....	404,786	186,362	228,425	248,053
Water temp. before entering pump	75.15	80.6	76.3	70.25
Water temperature, rise of.....	4.47	5.5	7.49	4.55
Water head by gauge on lift, ft....	29.90	54.05	54.05	29.90
Water head by gauge on suction..	12.26	12.26	19.67	19.67
Water head by gauge, total ( <i>H</i> )..	42.16	66.31	73.72	49.57
Water head by measure, total ( <i>h</i> )	32.8	57.80	66.6	41.60
Coeffi. of friction of plant, <i>h/H</i> ....	0.777	0.877	0.911	0.839
Efficiency of pulsometer.....	0.012	0.0155	0.0126	0.0138
Eff'y of plant exclusive of boiler	0.0093	0.0136	0.0115	0.0116
Eff'y of plant if that of boiler be 0.7	0.0065	0.0095	0.0080	0.0081
Duty, if 1 lb. evaporates 10 lbs. water.....	10,511,400	13,391,000	11,059,000	12,036,300

ticular head. The pressure used was intrusted to a practical runner, and he judged that when the pump was running regularly and well, the pressure then existing was the proper one. It is peculiar that, in the first test, a pressure of 19 lbs. of steam should produce a greater number of strokes and pump over 50% more water than 26.1 lbs., the lift being the same as in the fourth experiment.

Chas. E. Emery in discussion of Prof. Wood's paper says, referring to tests made by himself and others at the Centennial Exhibition in 1876 (see Report of the Judges, Group xx.), that a vacuum-pump tested by him in 1871 gave a duty of 4.7 millions; one tested by J. F. Flagg, at the Cincinnati Exposition in 1875, gave a maximum duty of 3.25 millions. Several vacuum and small steam-pumps, compared later on the same basis, were reported to have given duties of 10 to 11 millions, the steam-pumps doing no better than the vacuum-pumps. Injectors, when used for lifting water not required to be heated, have an efficiency of 2 to 5 millions; vacuum-pumps vary generally between 3 and 10; small steam-pumps between 8 and 15; larger steam-pumps, between 15 and 30, and pumping-engines between 30 and 140 millions.

A very high record of test of a pulsometer is given in *Eng'g*, Nov. 24, 1893, p. 639, viz.: Height of suction 11.27 ft.; total height of lift, 102.6 ft.; horizontal length of delivery-pipe, 118 ft.; quantity delivered per hour, 26,188 British gallons. Weight of steam used per H. P. per hour, 92.76 lbs.; work done per pound of steam 21,345 foot-pounds, equal to a duty of 21,345,000 foot-pounds per 100 lbs. of coal, if 10 lbs. of steam were generated per pound of coal.

**The Jet-pump.** — This machine works by means of the tendency of a stream or jet of fluid to drive or carry contiguous particles of fluid along with it. The water-jet pump, in its present form, was invented by Prof. James Thomson, and first described in 1852. In some experiments on a small scale as to the efficiency of the jet-pump, the greatest efficiency was found to take place when the depth from which the water was drawn by the suction-pipe was about nine tenths of the height from which the water fell to form the jet; the flow up the suction-pipe being in that case about one fifth of that of the jet, and the efficiency, consequently,  $\frac{9}{10} \times \frac{1}{5} = 0.18$ . This is but a low efficiency; but it is probable that it may be increased by improvements in proportions of the machine. (Rankine, S. E.)

**The Injector** when used as a pump has a very low efficiency. (See Injectors, under Steam-boilers.)

**GAS-ENGINE PUMPS.**

The **Humphrey Gas Pump** is a single-acting reciprocating pumping engine, the motive power of which is furnished by the explosion of a mixture of gas and air, as in a gas engine, the force of the explosion acting directly on the surface of a column of water in the vertical cylindrical part of a J or V-shaped pipe instead of on a reciprocating piston. The upper part of the cylinder contains the combustion chamber and valves similar to those of an Otto cycle gas engine. The lower part contains a suction valve box through which water enters into the "play pipe" and through which it passes to a surge tank and thence to the delivery pipe or reservoir. The charge of gas and air for starting is forced into the combustion chamber by a 2-cylinder air-compressor. When the explosion takes place the water is forced into the surge tank while the products of combustion expand to a low pressure, the inertia of the moving column of water in the play pipe causing it to continue in motion after the pressure upon it has decreased to atmospheric pressure. The scavenging valves of the gas cylinder and the suction valves of the water pump then open, admitting air and water. Most of the water follows the moving column in the play pipe while the rest rises in the explosion cylinder. After the kinetic energy in the moving column is expended in forcing water into the surge tank the column comes to rest and starts to flow back into the cylinder, the suction valves closing. When the surface reaches the level of the exhaust valves of the gas cylinder these are closed and the kinetic energy of the backward moving column is expended in compressing the imprisoned mixture of gases and scavenging air to a pressure higher than that of the surge tank, which starts the water moving downward again until the pressure is again reduced below that of the atmosphere. A fresh charge of gas and air is then drawn into the explosion chamber, compressed by the next return of the to-and-fro moving water column and then ignited. The motion of the water is similar to the swing of the pendulum of a clock, the time of vibration being nearly proportional to the square root of the length of the moving column. The pump was invented in 1906 by Mr. H. A. Humphrey. For illustrated descriptions see *Eng'g*, Nov. 26 and Dec. 3, 1909, and circulars of the Humphrey Gas Pump Co., Syracuse, N. Y., makers under the Humphrey and Smyth patents.

Tests of five pumps at Chingford, England, gave the following figures: Four pumps, capacity each 47,000 to 48,000 U. S. gal. per min.; lift 30 to 32 ft.; water H.P. developed, 301 to 323; gas used per min., 390 to 400 cu. ft. (at 60° F. and 30 in. bar.); heating value of gas (lower value) B.T.U. per cu. ft., 142 to 146; thermal efficiency, 22.19 to 24.07%; anthracite per water H.P.-hour, 0.881 to 0.957 lb. A smaller pump, capacity 26,000 U. S. gal. per min., gave a thermal efficiency of 26.63% and a coal consumption of 0.796 lb. per water H.P.-hour. The cylinders of the larger engine are 7 ft. diam., the play pipe, 6 ft. (*Eng'g*, Feb. 14, 1913).

A Humphrey gas pump of 26,000 gal. capacity per min. at 37 ft. head has been installed for irrigation purposes at Del Rio, Texas. It is guaranteed to deliver not less than 26,000 gal. per min. with a thermal efficiency of 20% when using producer gas of a heating value of not less than 100 B.T.U. per cu. ft. The principal dimensions are: Explosion cylinder, 66 in. diam. × 41 in.; water cylinder, 66 in. × 89 in. long; valve boxes, 66 in. × 73 in. long; number of 5-in. valves, 400; lift, 1 in.; total discharge area of valves, 4160 sq. in.; play pipe diam., 66 in., length, including 135° bend, 106 ft. Number of explosions, 12 to 20 per min.

Humphrey pumps without discharge valves are limited to heads of about 15 to 40 ft., but a pump with an intensifier and discharge valves is made for heads up to 150 ft.

**PUMPING BY COMPRESSED AIR—THE AIR-LIFT PUMP.**

**Air-lift Pump.**—The air-lift pump consists of a vertical water-pipe with its lower end submerged in a well, and a smaller pipe delivering air into it at the bottom. The rising column in the pipe consists of air mingled with water, the air being in bubbles of various sizes, and is therefore lighter than a column of water of the same height; consequently the



water in the pipe is raised above the level of the surrounding water. This method of raising water was proposed as early as 1797, by Loescher, of Freiberg, and was mentioned by Collon in lectures in Paris in 1876, but its first practical application probably was by Werner Siemens in Berlin in 1885. Dr. J. G. Pohle experimented on the principle in California in 1886, and U. S. patents on apparatus involving it were granted to Pohle and Hill in the same year. A paper describing tests of the air-lift pump made by Randall, Browne and Behr was read before the Technical Society of the Pacific Coast in Feb., 1890.

The diameter of the pump-column was 3 in., of the air-pipe 0.9 in., and of the air-discharge nozzle  $\frac{5}{8}$  in. The air-pipe had four sharp bends and a length of 35 ft. plus the depth of submersion.

The water was pumped from a closed pipe-well (55 ft. deep and 10 in. in diameter). The efficiency of the pump was based on the least work theoretically required to compress the air and deliver it to the receiver. If the efficiency of the compressor be taken at 70%, the efficiency of the pump and compressor together would be 70% of the efficiency found for the pump alone.

For a given submersion ( $h$ ) and lift ( $H$ ), the ratio of the two being kept within reasonable limits, ( $H$ ) being not much greater than ( $h$ ), the efficiency was greatest when the pressure in the receiver did not greatly exceed the head due to the submersion. The smaller the ratio  $H \div h$ , the higher was the efficiency.

The pump, as erected, showed the following efficiencies:

For $H \div h =$	0.5	1.0	1.5	2.0
Efficiency =	50%	40%	30%	25%

The fact that there are absolutely no moving parts makes the pump especially fitted for handling dirty or gritty water, sewage, mine water, and acid or alkali solutions in chemical or metallurgical works.

In Newark, N. J., pumps of this type are at work having a total capacity of 1,000,000 gallons daily, lifting water from three 8-in. artesian wells. The Newark Chemical Works use an air-lift pump to raise sulphuric acid of 1.72° gravity. The Colorado Central Consolidated Mining Co., in one of its mines at Georgetown, Colo., lifts water in one case 250 ft., using a series of lifts.

For a full account of the theory of the pump, and details of the tests above referred to, see *Eng'g News*, June 8, 1893.

Numerous tests of air-lift pumps are described in Greene's "Pumping Machinery." Greene says that the air pipe should be introduced near the bottom of the discharge pipe and should be immersed so that the ratio  $h_1/h$  is 3 to 1 at the start and 2.2 to 1 in operation.  $h_1$  is the depth of immersion below the water level and  $h$  the height of the discharge at the top of the well measured above the water level. Different tests give the following efficiencies for various ratios  $h_1/h$ .

$h/h_1 =$	3.1 to 2.2	0.6	1	1.4	2.4	3.9	1.5	1	0.66	0.5	0.43
Efficiency, %:	36	16 to 43	19 to 42	34 to 41	15 to 24	2	50	40	30	25	20

The efficiency is the ratio of the work done in raising the water to the work of compressing the air.

The amount of free air required varies according to different manufacturers. One gives cu. ft. air per min. =  $LW \div 19$ ; another  $LW \div 15$ ;  $L$  = lift of water above the water level, in ft.,  $W$  = cu. ft. of water per min.

**Air-Lifts for Deep Oil-Wells** are described by E. M. Ivens, in *Trans. A. S. M. E.* 1909, p. 341. The following are some results obtained in wells in Evangeline, La.:

Cu. ft. free air per minute, displacement of compressor.....	650	442	702	536
Cu. ft. oil pumped per minute.....	4.35	4.87	13.7	5.54
Air pressure at well, lbs. per sq. in.....	155	200	202	252
Pumping head, from oil level while pumping, ft.	1155	1081	1076	917
Submergence, from oil level to air entrance, ft.	358	412	419	583
Submergence $\div$ total ft. of vertical pipe, %...	23.6	27.6	28	39
Pumping efficiency, %.....	9.3	13.4	19.5	10.3

**Artesian Well Pumping by Compressed Air.**—H. Tipper, *Eng. News*, Jan. 16, 1908, mentions cases where 1-in. air lines supplied air for 6-in. wells, with the inside air-pipe system; the length of the pipe was 300 ft. from the well top, and another 350 ft. to the compressor. The wells pumped 75 gals. per min., using 200 cu. ft. of air, the efficiency being 61½%. Changing the pipes to 2½ in. above the well, and 2 in. in the well, and putting an air receiver near the compressor, raised the delivery to 180 gals. per min., with a little less air, and the efficiency to 23%. A large receiver capacity, a large pipe above ground, a submergence of 55%, well piping proportioned for a friction loss of not over 5%, with lifts not over 200 ft., gave the best results, 1 gal. of water being raised per cu. ft. of air. The utmost net efficiency of the air-lift is not over 25 to 30%.

*Eng. News*, June 18, 1908, contains an account of tests of eleven wells at Atlantic City. The Atlantic City wells were 10 in. diam., water pipes, 4 to 5¼ in., air pipes, ¾ to 1¼ in. The maximum lift of the several wells ranged from 26 to 40 ft., the submergence, 37 to 49 ft., ratio of submergence to lift, 0.9 to 1.8, submergence % of length of pipe, 53 to 64. Capacity test, 3,544,900 gals. in 24 hrs., mean lift, 26.88 ft., air pressure, 31 lbs., duty of whole plant, 19,900,000 ft. lbs. per 1000 lbs. of steam used by the compressors. Two-thirds capacity test, delivery, 2,642,900 gals., mean lift, 25.43 ft., air pressure, 26 lbs., duty, 24,207,000.

An article in *The Engineer* (Chicago), Aug. 15, 1904, gives the following formulæ and rules for the design of air-lifts of maximum efficiency. The authority is not given.

Ratio of area of air pipe to area of water pipe, 0.16.

Submerged portion = 65% of total length of pipe.

Economical range of submergence ratio, 55 to 80%.

Velocity of air in air pipe, not over 4000 ft. per min.

Volume of air to raise 1 cu. ft. of water, 3.9 to 4.5 cu. ft.

$C$  = cu. ft. of water raised per min.,  $A$  = cu. ft. of air used,  $L$  = lift above water level,  $D$  = submergence, in feet.

$A = LC \div 16.824$ ;  $C = 8.24 AD \div L^2$ .

Where  $L$  exceeds 180 ft. it will be more economical to use two or more air-lifts in series.

### THE HYDRAULIC RAM.

**Efficiency.**—The hydraulic ram is used where a considerable flow of water with a moderate fall is available, to raise a small portion of that flow to a height exceeding that of the fall. The following are rules given by Eytelwein as the results of his experiments (from Rankine):

Let  $Q$  be the whole supply of water in cubic feet per second, of which  $q$  is lifted to the height  $h$  above the pond, and  $Q - q$  runs to waste at the depth  $H$  below the pond;  $L$ , the length of the supply-pipe, from the pond to the waste-clack;  $D$ , its diameter in feet; then

$$D = \sqrt{(1.63 Q)}; L = H + h + \frac{h}{H} \times 2 \text{ feet};$$

Efficiency,  $\frac{qh}{(Q-q)H} = 1.12 - 0.2 \sqrt{\frac{h}{H}}$ , when  $\frac{h}{H}$  does not exceed 20;

or  $1 \div (1 + h/10 H)$  nearly, when  $h/H$  does not exceed 12.

D'Aubuisson gives  $\frac{q(H+h)}{QH} = 1.42 - 0.28 \sqrt{\frac{h}{H}}$ .

Clark, using five sixths of the values given by D'Aubuisson's formula, gives:

Ratio of lift to fall.	4	6	8	10	12	14	16	18	20	22	24	26
Efficiency per cent.	72	61	52	44	37	31	25	19	14	9	4	0

The efficiency as calculated by the two formulæ given above is nearly the same for high ratios of lift, but for low ratios there is considerable difference. For example:

Let $Q = 100$ , $H = 10$ , $H + h =$	20	40	100	200
Efficiency, D'Aubuisson's formula, %	80	72	44	14
$q = \text{effy.} \times QH \div (H + h) =$	40	18	4.4	0.7
Efficiency by Rankine's formula, %	66⅔	65.9	41.4	13.4

D'Aubuisson's formula is that of the machine itself, on the basis that

the energy put into the machine is that of the whole column of water,  $Q$ , falling through the height  $h$  and that the energy delivered is that of  $q$  raised through the whole height above the ram,  $H + h$ ; while Rankine's efficiency is that of the whole plant, assuming that the energy put in is only that of the water that runs to waste, and that the work done is lifting the quantity  $q$  not from the level of the ram but only from that of the supply pond. D'Aubuisson's formula is the one in harmony with the usual definition of efficiency. It also is applicable (as Rankine's is not) to the case of a ram which uses the quantity  $Q$  from one source of supply to pump water of different quality from a source at the level of the ram.

An extensive mathematical investigation of the hydraulic ram, by L. F. Harza, is contained in Bulletin No. 205 of the University of Wisconsin, 1908, together with results of tests of a Rife "hydraulic engine," which appear to verify the theory. It was found both by theory and by experiment that the efficiency bears a relation to the velocity in the drive pipe. From plotted diagrams of the results the following figures (roughly approximate) are taken: Length of 2-in. drive pipe, 85.4 ft.; supply head, 8.2 ft.

Max. vel. in drive pipe, ft. per sec. . . . .	1.5	2	3	4	5	6
	Efficiency of machine, %.					
Pumping head, ft. . . . .	2.6	30	20	15	7	0
	12.3	60	45	33	18	0
	23.2	60	65	53	40	20
	43.5	55	60	53	42	30
	63.1	60	55	50	28	0

The author of the paper concludes that the comparison of experiment and theory has demonstrated the practicability of the logical design of a hydraulic ram for any given working conditions.

An interesting historical account, with illustrations, of the development of the hydraulic ram, with a description of Pearsall's hydraulic engine, is given by J. Richards in *Jour. Assn. Eng'g Societies*, Jan., 1898. For a description of the Rife hydraulic engine see *Eng. News*, Dec. 31, 1896.

The Columbia Steel Co., Portland, Ore., furnished the author in July, 1908, records of tests of four hydraulic rams, from which the following is condensed, the efficiency, by D'Aubuisson's formula, being calculated from the data given.  $L$  = length in ft. and  $D$  = diam. in ins. of the drive pipe,  $l$  and  $d$ , length and diameter of the discharge pipe.

Size of Ram.	$H$	$\frac{h+H}{H}$	$Q^*$	$q^*$	$L$	$D$	$l$	$d$	Effy. %
Ins.	Ft.	Ft.			Ft.	Ins.	Ft.	Ins.	
3	4	28	35	3.5	28	3	1008	11/2	58.9
4 1/2	5	45	100	8	40	4 1/2	325	.....	72.0
6	12	36.4	200	50.5	60	4 1/2	945	2 1/2	76.6
6	37.6	144.1	6.26	1.15	192.5	6	1785	10†	70.4

\*  $Q$  and  $q$  are in gallons per min., except the last line, which is in cu. ft. per sec.

† Eleven rams discharge into one 10-in. jointed wood pipe. The loss of head in the drive pipe was 0.7 ft., and in the discharge pipe, 2.7 ft. On another test 1 cu. ft. per sec. was delivered with less than 5 cu. ft. entering the drive pipe. Taking 5 cu. ft. gives 76.6% efficiency.

A description and record of test of the Foster "impact engine" is given in *Eng'g News*, Aug. 3, 1905. Two engines are connected into one 8-in. delivery pipe. Using the same notation as before, the data of the tests of the two engines are as follows:  $Q$ , gal. per min., 582, 578;  $q$ , 232, 228;  $H$ , 36.75, 37.25;  $H + h$ , 84, 84; strokes per min., 130, 130; Effy. (D'Aubuisson), 91.23, 89.06%.

Prof. R. C. Carpenter (*Eng'g Mechanics*, 1894) reports the results of four tests of a ram constructed by Rumsey & Co., Seneca Falls. The supply-pipe used was 1 1/2 inches in diameter, about 50 feet long, with 3 elbows. Each run was made with a different stroke for the waste-valve, the supply and delivery head being constant; the object of the experi-



ment was to find that stroke of clack-valve which would give the highest efficiency.

Length of stroke, per cent .....	100	80	60	46
Number of strokes per minute .....	52	56	61	66
Supply head, feet of water .....	5.67	5.77	5.58	5.65
Delivery head, feet of water .....	19.75	19.75	19.75	19.75
Total water pumped, pounds .....	297	296	301	297.5
Total water supplied, pounds .....	1615	1567	1518	1455.5
Efficiency, per cent .....	64.1	64.7	70.2	71.4

The highest efficiency realized was obtained when the clack-valve traveled 60% of its full stroke, the full travel being  $15/16$  in.

### HYDRAULIC-PRESSURE TRANSMISSION.

Water under high pressure (700 to 2000 lbs. per sq. in. and upwards) affords a satisfactory method of transmitting power to a distance, especially for the movement of heavy loads at small velocities, as by cranes and elevators. The system consists usually of one or more pumps capable of developing the required pressure; accumulators, which are vertical cylinders with heavily-weighted plungers passing through stuffing-boxes in the upper end, by which a quantity of water may be accumulated at the pressure to which the plunger is weighted; the distributing-pipes; and the presses, cranes, or other machinery to be operated.

The earliest important use of hydraulic pressure probably was in the Bramah hydraulic press, patented in 1796. Sir, W. G. Armstrong in 1846 was one of the pioneers in the adaptation of the hydraulic system to cranes. The use of the accumulator by Armstrong led to the extended use of hydraulic machinery. Recent developments and applications of the system are largely due to Ralph Tweddell, of London, and Sir Joseph Whitworth. Sir Henry Bessemer, in his patent of May 13, 1856, No. 1292, first suggested the use of hydraulic pressure for compressing steel ingots while in the fluid state.

**The Gross Amount of Energy** of the water under pressure stored in the accumulator, measured in foot-pounds, is its volume in cubic feet  $\times$  its pressure in pounds per square foot. The horse-power of a given quantity steadily flowing is  $H.P. = 144 pQ/550 = 0.2618 pQ$ , in which  $Q$  is the quantity flowing in cubic feet per second and  $p$  the pressure in pounds per square inch.

The loss of energy due to velocity of flow in the pipe is calculated as follows (R. G. Blaine, *Eng'g*, May 22 and June 5, 1891):

According to Darcy, every pound of water loses  $\lambda 4L/D$  times its kinetic energy, or energy due to its velocity, in passing along a straight pipe  $L$  feet in length and  $D$  feet diameter, where  $\lambda$  is a variable coefficient. For clean cast-iron pipes it may be taken as  $\lambda = 0.005 \left(1 + \frac{1}{12D}\right)$ , or for diameter in inches =  $d$ .

$d = 1/2 \quad 1 \quad 2 \quad 3 \quad 4 \quad 5 \quad 6 \quad 7 \quad 8 \quad 9 \quad 10 \quad 12$   
 $\lambda = .015 .01 \quad .0075 \quad .00667 \quad .00625 \quad .006 \quad .00583 \quad .00571 \quad .00563 \quad .00556 \quad .0055 \quad .00542$

The loss of energy per minute is  $60 \times 62.36 Q \times \frac{\lambda 4L}{D} \frac{v^2}{2g}$ , and the

horse-power wasted in the pipe is  $W = \frac{0.6363 \lambda L (H.P.)^3}{p^3 D^5}$ , in which  $\lambda$

varies with the diameter as above.  $p$  = pressure at entrance in pounds per square inch. Values of  $0.6363 \lambda$  for different diameters of pipe in inches are:

$d = 1/2 \quad 1 \quad 2 \quad 3 \quad 4 \quad 5 \quad 6 \quad 7 \quad 8$   
 $.00954 \quad .00636 \quad .00477 \quad .00424 \quad .00398 \quad .00382 \quad .00371 \quad .00363 \quad .00358$   
 $9 \quad 10 \quad 12$   
 $.00353 \quad .00350 \quad .00345$

**Efficiency of Hydraulic Apparatus.** — The useful effect of a direct hydraulic plunger or ram is usually taken at 93%. The following is given as the efficiency of a ram with chain-and-pulley multiplying gear properly proportioned and well lubricated:

Gear 2 to 1    4 to 1    6 to 1    8 to 1    10 to 1    12 to 1    14 to 1    16 to 1  
 Eff'y 0.80    0.76    0.72    0.67    0.63    0.59    0.54    0.50

With large sheaves, small steel pins, and wire rope for multiplying gear the efficiency has been found as high as 66% for a multiplication of 20 to 1.

Henry Adams gives the following formula for effective pressure in cranes and hoists:  $P$  = accumulator pressure in pounds per square inch;  $m$  = ratio of multiplying power;  $E$  = effective pressure in pounds per square inch, including all allowances for friction;

$$E = P (0.84 - 0.02 m).$$

J. E. Tuit (*Eng'g*, June 15, 1888) describes some experiments on the friction of hydraulic jacks from 3 $\frac{1}{4}$  to 13 $\frac{5}{8}$ -inch diameter, fitted with cupped leather packings. The friction loss varied from 5.6% to 18.8% according to the condition of the leather, the distribution of the load on the ram, etc. The friction increased considerably with eccentric loads. With hemp packing a plunger, 14-inch diameter, showed a friction loss of from 11.4% to 3.4%, the load being central, and from 15.0% to 7.6% with eccentric load, the percentage of loss decreasing in both cases with increase of load.

**Thickness of Hydraulic Cylinders.** — Sir W. G. Armstrong gives the following, for cast-iron cylinders, for a pressure of 1000 lbs. per sq. in.:

Diam. of cylinder, inches —	2	4	6	8	10	12	16	20	24
Thickness, inches —	0.832	1.146	1.552	1.875	2.222	2.578	3.19	3.69	4.11

For any other pressure multiply by the ratio of that pressure to 1000. These figures correspond nearly to the formula  $t = 0.175 d + 0.48$ , in which  $t$  = thickness and  $d$  = diameter in inches, up to 16 inches diameter, but for 20 inches diameter the addition 0.48 is reduced to 0.19 and at 24 inches it disappears. For formulæ for thick cylinders see page 339.

Cast iron should not be used for pressures exceeding 2000 lbs. per square inch. For higher pressures steel castings or forged steel should be used. For working pressures of 750 lbs. per square inch the test pressure should be 2500 lbs. per square inch, and for 1500 lbs. the test pressure should not be less than 3500 lbs.

**Speed of Hoisting by Hydraulic Pressure.** — The maximum allowable speed for warehouse cranes is 6 feet per second; for platform cranes 4 feet per second; for passenger and wagon hoists, heavy loads, 2 feet per second. The maximum speed under any circumstances should never exceed 10 feet per second.

**The Speed of Water Through Valves** should never be greater than 100 feet per second.

**Speed of Water Through Pipes.** — Experiments on water at 1600 lbs. pressure per square inch flowing into a flanging-machine ram, 20-inch diameter, through a  $\frac{1}{2}$ -inch pipe contracted at one point to  $\frac{1}{4}$ -inch, gave a velocity of 114 feet per second in the pipe, and 456 feet at the reduced section. Through a  $\frac{1}{2}$ -inch pipe reduced to  $\frac{3}{8}$ -inch at one point the velocity was 213 feet per second in the pipe and 381 feet at the reduced section. In a  $\frac{1}{2}$ -inch pipe without contraction the velocity was 355 feet per second.

For many of the above notes the author is indebted to Mr. John Platt, consulting engineer, of New York.

**High-pressure Hydraulic Presses in Iron-works** are described by R. M. Daelen, of Germany, in *Trans. A. I. M. E.*, 1892. The following distinct arrangements used in different systems of high-pressure hydraulic work are discussed and illustrated:

1. Steam-pump, with fly-wheel and accumulator.
2. Steam-pump, without fly-wheel and with accumulator.
3. Steam-pump, without fly-wheel and without accumulator.

In these three systems the valve-motion of the working press is operated in the high-pressure column. This is avoided in the following:

4. Single-acting steam-intensifier without accumulator.
5. Steam-pump with fly-wheel, without accumulator and with pipe-circuit.
6. Steam-pump with fly-wheel, without accumulator and without pipe-circuit.

The disadvantages of accumulators are thus stated: The weighted

plungers which formerly served in most cases as accumulators, cause violent shocks in the pipe-line when changes take place in the movement of the water, so that in many places, in order to avoid bursting from this cause, the pipes are made exclusively of forged and bored steel. The seats and cones of the metallic valves are cut by the water (at high speed), and in such cases only the most careful maintenance can prevent great losses of power.

**Hydraulic Power in London.** — The general principle involved is pumping water into mains laid in the streets, from which service-pipes are carried into the houses to work lifts or three-cylinder motors when rotary power is required. In some cases a small Pelton wheel has been tried, working under a pressure of over 700 lbs. on the square inch. Over 55 miles of hydraulic mains are at present laid (1892).

The reservoir of power consists of capacious accumulators, loaded to 800 lbs. per sq. in.

The engine-house contains six sets of triple-expansion pumping engines. Each pump will deliver 300 gallons of water per minute.

The water delivered from the main pumps passes into the accumulators. The rams are 20 inches in diameter, and have a stroke of 23 feet. They are each loaded with 110 tons of slag, contained in a wrought-iron cylindrical box suspended from a cross-head on the top of the ram. One of the accumulators is loaded a little more heavily than the other, so that they rise and fall successively; the more heavily loaded actuates a stop-valve on the main steam-pipe.

The mains in the public streets are so constructed and laid as to be perfectly trustworthy and free from leakage. Every pipe and valve used throughout the system is tested to 2500 lbs. per sq. in. before being placed on the ground and again tested to a reduced pressure in the trenches to insure the perfect tightness of the joints. The jointing material used is gutta-percha.

The average rate obtained by the company is about 3 shillings per thousand gallons. The principal use of the power is for intermittent work in cases where direct pressure can be employed, as, for instance, passenger elevators, cranes, presses, warehouse hoists, etc.

An important use of the hydraulic power is its application to the extinguishing of fire by means of Greathead's injector hydrant. By the use of these hydrants a continuous fire-engine is available.

**Hydraulic Riveting-machines.** — Hydraulic riveting was introduced in England by Mr. R. H. Tweddell. Fixed riveters were first used about 1868. Portable riveting-machines were introduced in 1872.

The riveting of the large steel plates in the Forth Bridge was done by small portable machines working with a pressure of 1000 lbs. per square inch. In exceptional cases 3 tons per inch were used. (*Proc. Inst. M. E.*, May, 1889.)

An application of hydraulic pressure invented by Andrew Higginson, of Liverpool, dispenses with the necessity of accumulators. It consists of a three-throw pump driven by shafting or worked by steam and depends partially upon the work accumulated in a heavy fly-wheel. The water in its passage from the pumps and back to them is in constant circulation at a very feeble pressure, requiring a minimum of power to preserve the tube of water ready for action at the desired moment, when by the use of a tap the current is stopped from going back to the pumps, and is thrown upon the piston of the tool to be set in motion. The water is now confined, and the driving-belt or steam-engine, supplemented by the momentum of the heavy fly-wheel, is employed in closing up the rivet, or bending or forging the object subjected to its operation.

#### Hydraulic Forging-press.

For a very complete illustrated account of the development of the hydraulic forging-press, see a paper by R. H. Tweddell in *Proc. Inst. C. E.*, vol. cxvii. 1893-4.

In the Allen forging-press the force-pump and the large or main cylinder of the press are in direct and constant communication. There are no intermediate valves of any kind, nor has the pump any check-valves, but it simply forces its cylinder full of water direct into the cylinder of the press, and receives the same water, as it were, back again on the return



stroke. Thus, when both cylinders and the pipe connecting them are full, the large ram of the press rises and falls simultaneously with each stroke of the pump, keeping up a continuous oscillating motion, the ram, of course, traveling the shorter distance, owing to the larger capacity of the press cylinder. (*Journal Iron and Steel Institute*, 1891. See also illustrated article in "Modern Mechanism," page 668.)

A 2000-ton forging-press erected at the Couillet forges in Belgium is described in *Eng. and M. Jour.*, Nov. 25, 1893. The press is composed essentially of two parts — the press itself and the compressor. The compressor is formed of a vertical steam-cylinder and a hydraulic cylinder. The piston-rod of the former forms the piston of the latter. The hydraulic piston discharges the water into the press proper. The distribution is made by a cylindrical balanced valve; as soon as the pressure is released the steam-piston falls automatically under the action of gravity. During its descent the steam passes to the other face of the piston to reheat the cylinder, and finally escapes from the upper end.

When steam enters under the piston of the compressor-cylinder the piston rises, and its rod forces the water into the press proper. The pressure thus exerted on the piston of the latter is transmitted through a cross-head to the forging which is upon the anvil. To raise the cross-head two small single-acting steam-cylinders are used, their piston-rods being connected to the cross-head: steam acts only on the pistons of these cylinders from below. The admission of steam to the cylinders, which stand on top of the press frame, is regulated by the same lever which directs the motions of the compressor. The movement given to the dies is sufficient for all the ordinary purposes of forging.

A speed of 30 blows per minute has been attained. A double press on the same system, having two compressors and giving a maximum pressure of 6000 tons, has been erected in the Krupp works, at Essen.

**Hydraulic Engine driving an Air-compressor and a Forging-hammer.** (*Iron Age*, May 12, 1892.) — The great hammer in Terni, near Rome, is one of the largest in existence. Its falling weight amounts to 100 tons, and the foundation belonging to it consists of a block of cast iron of 1000 tons. The stroke is 16 feet  $4\frac{3}{4}$  inches; the diameter of the cylinder 6 feet  $3\frac{1}{2}$  inches; diameter of piston-rod  $13\frac{3}{4}$  inches; total height of the hammer, 62 feet 4 inches. The power to work the hammer, as well as the two cranes of 100 and 150 tons respectively, and other auxiliary appliances belonging to it, is furnished by four air-compressors coupled together and driven directly by water-pressure engines, by means of which the air is compressed to 73.5 pounds per square inch. The cylinders of the water-pressure engines, which are provided with a bronze lining, have a  $13\frac{3}{4}$ -inch bore. The stroke is  $47\frac{3}{4}$  inches, with a pressure of water on the piston amounting to 264.6 pounds per square inch. The compressors are bored out to  $31\frac{1}{2}$  inches diameter, and have  $47\frac{3}{4}$ -inch stroke. Each of the four cylinders requires a power equal to 280 horse-power. The compressed air is delivered into huge reservoirs, where a uniform pressure is kept up by means of a suitable water-column.

**The Hydraulic Forging Plant at Bethlehem, Pa.**, is described in a paper by R. W. Davenport, read before the Society of Naval Engineers and Marine Architects, 1893. It includes two hydraulic forging-presses complete, with engines and pumps, one of 1500 and one of 4500 tons capacity, together with two Whitworth hydraulic traveling forging-cranes and other necessary appliances for each press; and a complete fluid-compression plant, including a press of 7000 tons capacity and a 125-ton hydraulic traveling crane for serving it (the upper and lower heads of this press weighing respectively about 135 and 120 tons).

A later forging-press designed by John Fritz, for the Bethlehem Works, of 14,000 tons capacity, is run by engines and pumps of 15,000 horse-power. The plant is served by four open-hearth steel furnaces of a united capacity of 120 tons of steel per heat.

**The Davy High-speed Steam-hydraulic Forging Press** is described in the *Iron Age*, April 15, 1909. It is built in sizes ranging from 150 to 12,000 tons capacity. In the four-column type, in which all but the smaller sizes are built, there is a central press operated by hydraulic pressure from a steam intensifier, and two steam balance cylinders carried on top of the entablature. A single lever controls the press. The operator admits steam to the balance cylinders, lifting the cross-

head and the main plunger, and forcing the water from the press cylinder into the water cylinder of the intensifier. Exhausting the steam from the balance cylinders, allows the plunger to descend and rest on the forging. To and fro motions of the lever, slow or fast as the operator desires, up to 120 a minute, then are made to reduce the forging. The smaller, or single frame, type has only one balance cylinder, immediately above the press cylinder. The Davy press is made in the United States by the United Engineering & Foundry Co., Pittsburgh.

**Some References on Hydraulic Transmission.** — Reuleaux's "Constructor;" "Hydraulic Motors, Turbines, and Pressure-engines," G. Bodmer, London, 1889; Robinson's "Hydraulic Power and Hydraulic Machinery," London, 1888; Colyer's "Hydraulic Steam, and Hand-power Lifting and Pressing Machinery," London, 1881. See also *Engineering* (London), Aug. 1, 1884, p. 99; March 13, 1885, p. 262; May 22 and June 5, 1891, pp. 612, 665; Feb. 19, 1892, p. 25; Feb. 10, 1893, p. 170.

## FUEL.

**Theory of Combustion of Solid Fuel.** (From Rankine, somewhat altered.) — The ingredients of every kind of fuel commonly used may be thus classed: (1) Fixed or free carbon, which is left in the form of charcoal or coke after the volatile ingredients of the fuel have been distilled away. These ingredients burn either wholly in the solid state ( $C$  to  $CO_2$ ), or part in the solid state and part in the gaseous state ( $CO + O = CO_2$ ), the latter part being first dissolved by previously formed carbon dioxide by the reaction  $CO_2 + C = 2CO$ . Carbon monoxide,  $CO$ , is produced when the supply of air to the fire is insufficient.

(2) Hydrocarbons, such as olefiant gas, pitch, tar, naphtha, etc., all of which must pass into the gaseous state before being burned.

If mixed on their first issuing from amongst the burning carbon with a large quantity of hot air, these inflammable gases are completely burned with a transparent blue flame, producing carbon dioxide and steam. When mixed with cold air they are apt to be chilled and pass off unburned. When raised to a red heat, or thereabouts, before being mixed with a sufficient quantity of air for perfect combustion, they disengage carbon in fine powder, and pass to the condition partly of marsh gas,  $CH_4$  and partly of free hydrogen; and the higher the temperature, the greater is the proportion of carbon thus disengaged.

If the disengaged carbon is cooled below the temperature of ignition before coming in contact with oxygen, it constitutes, while floating in the gas, smoke, and when deposited on solid bodies, soot.

But if the disengaged carbon is maintained at the temperature of ignition and supplied with oxygen sufficient for its combustion, it burns while floating in the inflammable gas, and forms red, yellow, or white flame. The flame from fuel is the larger the more slowly its combustion is effected. The flame itself is apt to be chilled by radiation, as into the heating surface of a steam-boiler, so that the combustion is not completed, and part of the gas and smoke pass off unburned.

(3) Oxygen or hydrogen either actually forming water, or existing in combination with the other constituents in the proportions which form water. Such quantities of oxygen and hydrogen are to be left out of account in determining the heat generated by the combustion. If the quantity of water actually or virtually present in each pound of fuel is so great as to make its latent heat of evaporation worth considering, that heat is deducted from the total available heat of combustion of the fuel.

(4) Nitrogen, either free or in combination with other constituents. This substance is simply inert.

(5) Sulphide of iron, which exists in coal and is detrimental, as tending to cause spontaneous combustion.

(6) Other inert mineral compounds of various kinds form the ash left after complete combustion of the fuel, and also the clinker or glassy material produced by fusion of the ash, which tends to choke the grate.

The imperfect combustion of carbon, making carbon monoxide, produces less than one-third of the heat which is yielded by the complete combustion, making carbon dioxide.

The total heat of combustion of any compound of hydrogen and carbon is nearly the sum of the quantities of heat which the constituents would produce separately by their combustion. (Marsh-gas is an exception.)

In computing the total heat of combustion of compounds containing oxygen as well as hydrogen and carbon, the following principle is to be observed: When hydrogen and oxygen exist in a compound in the proper proportion to form water (that is, by weight one part of hydrogen to eight of oxygen), these constituents have no effect on the total heat of combustion. If hydrogen exists in a greater proportion, only the surplus of hydrogen above that which is required by the oxygen is to be taken into account.

The following is a general formula (Dulong's) for the total heat of combustion of any compound of carbon, hydrogen, and oxygen:

Let *C*, *H*, and *O* be the fractions of one pound of the compound, which consists respectively of carbon, hydrogen, and oxygen, the remainder being nitrogen, ash, and other impurities. Let *h* be the total heat of combustion of one pound of the compound in British thermal units.

Then 
$$h = 14,600 C + 62,000 (H - \frac{1}{8} O).$$

**Oxygen and Air Required for the Combustion of Carbon, Hydrogen, etc.**

Chemical Reaction.	Lbs. O per lb. Fuel.	Lbs. N = 3.32 O	Air per lb. = 4.32 O.	Gaseous Products per lb.	Heat of Combustion, B.T.U. per lb.
C to CO <sub>2</sub> C + 2O = CO <sub>2</sub>	2 2/3	8.85	11.52	12.52	14,600
C to CO        C + O = CO	1 1/3	4.43	5.76	6.76	4,450
CO to CO <sub>2</sub> CO + O = CO <sub>2</sub>	4/7	1.90	2.47	3.47	4,350
H to H <sub>2</sub> O      2H + O = H <sub>2</sub> O	8	26.56	34.56	35.56	62,000
CH <sub>4</sub> to CO <sub>2</sub> } and H <sub>2</sub> O }    CH <sub>4</sub> + 4O = CO <sub>2</sub> + 2H <sub>2</sub> O	4	13.28	17.28	18.28	23,600
S to SO <sub>2</sub> S + 2O = SO <sub>2</sub>	1	3.32	4.32	5.32	4,050

CO to CO<sub>2</sub>, per lb. of C or per 2 1/3 lb. of CO, 14,600 - 4,450 = 10,150.

For heat of combustion of various fuels see Heat, page 560.

**Analyses of Gases of Combustion.**—The following are selected from a large number of analyses of gases from locomotive boilers, to show the range of composition under different circumstances (P. H. Dudley, *Trans. A. I. M. E.*, iv, 250):

Test.	CO <sub>2</sub>	CO	O	N	
1	13.8	2.5	2.5	81.6	No smoke visible.
2	11.5	.....	6	82.5	Old fire, escaping gas white, engine working hard.
3	8.5	.....	8	83	Fresh fire, much black gas, engine working hard.
4	2.3	.....	17.2	80.5	Old fire, damper closed, engine standing still.
5	5.7	.....	14.7	79.6	" " smoke white, engine working hard.
6	8.4	1.2	8.4	82	New fire, engine not working hard.
7	12	1	4.4	82.6	Smoke black, engine not working hard.
8	3.4	.....	16.8	76.8	" dark, blower on, engine standing still.
9	6	.....	13.5	81.5	" white, engine working hard.

In analyses on the Cleveland and Pittsburgh road, in every instance when the smoke was the blackest, there was found the greatest percentage of unconsumed oxygen in the product, showing that something besides the mere presence of oxygen is required to effect the combustion of the volatile carbon of fuels. (What is needed is thorough mixture of the oxygen with the volatile gases in a hot combustion chamber.)

**Temperature of the Fire.** (Rankine, S. E., p. 283.) — By temperature of the fire is meant the temperature of the products of combustion at the instant that the combustion is complete. The elevation of that temperature above the temperature at which the air and the fuel are supplied to the furnace may be computed by dividing the total heat of



combustion of one lb. of fuel by the weight and by the mean specific heat of the whole products of combustion, and of the air employed for their dilution under constant pressure.

**Temperature of the Fire, the Fuel Containing Hydrogen and Water.** — The following formula is developed in the author's "Steam-boiler Economy" on the assumptions that all the hydrogen and the water exist in the combustion chamber as superheated steam at the temperature of the fire, and that the specific heat of the gases is a constant, = 0.237. The last assumption is probably largely in error, since it is now known that the specific heat of gases increases with the temperature. (See page 564.) The formula will give approximate results, however, and is sufficiently accurate when relative figures only are desired.

Let *C*, *H*, *O*, and *W* represent respectively the percentages of carbon, hydrogen, oxygen, and water in a fuel, and *f* the pounds of dry gas per pound of fuel, =  $CO_2 + N + \text{excess air}$ , then the theoretical elevation of the temperature of the fire above the temperature of the atmosphere,

$$T = \frac{616 C + 2200 H - 327 O - 44 W}{f + 0.02 W + 0.18 H}$$

**EXAMPLE.** — Required the maximum temperature obtainable by burning moist wood of the composition *C*, 38; *H*, 5; *O*, 32; ash, 1; moisture 24; the dry gas being 15 lbs. per pound of wood, and the temperature of the atmosphere 62°.

$$T = \frac{616 \times 38 + 2220 \times 5 - 327 \times 32 - 44 \times 24}{15 + 0.02 \times 24 + 0.18 \times 5} = 1403, \text{ add } 62^\circ = 1465^\circ.$$

**Rise of Temperature in Combustion of Gases.** (*Eng'g*, March 12 and April 2, 1886.) — It is found that the temperatures obtained by experiment fall short of those obtained by calculation. Three theories have been given to account for this: 1. The cooling effect of the sides of the containing vessel; 2. The retardation of the evolution of heat caused by dissociation; 3. The increase of the specific heat of the gases at very high temperatures. The calculated temperatures are obtainable only on the condition that the gases shall combine instantaneously and simultaneously throughout their whole mass. This condition is practically impossible in experiments. The gases formed at the beginning of an explosion dilute the remaining combustible gases and tend to retard or check the combustion of the remainder.

### CLASSIFICATION OF SOLID FUELS.

Gruner classifies solid fuels as follows (*Eng'g and M'g Jour.*, July, 1874).

Name of Fuel.	Ratio $\frac{O}{H}$ or $\frac{O+N^*}{H}$ .	Proportion of Coke or Charcoal yielded by the Dry Pure Fuel.
Pure cellulose.....	8.	0.28 @ 0.30
Wood (cellulose and encasing matter)..	7	.30 @ .35
Peat and fossil fuel.....	6 @ 5	.35 @ .40
Lignite, or brown coal.....	5	.40 @ .50
Bituminous coals.....	4 @ 1	.50 @ .90
Anthracite.....	1 @ 0.75	.90 @ .92

\* The nitrogen rarely exceeds 1 per cent of the weight of the fuel.

### Progressive Change from Wood to Graphite.

(J. S. Newberry in Johnson's Cyclopedia.)

	Wood.	Loss.	Lignite.	Loss.	Bituminous Coal.	Loss.	Anthracite.	Loss.	Graphite.
Carbon.....	49.1	18.65	30.45	12.35	18.10	3.57	14.53	1.42	13.11
Hydrogen.....	6.3	3.25	3.05	1.85	1.20	0.93	0.27	0.14	0.13
Oxygen.....	44.6	24.40	20.20	18.13	2.07	1.32	0.65	0.65	0.00
	100.0	46.30	53.70	32.33	21.37	5.82	15.45	2.21	13.24

**Classification of Coals.**

It is convenient to classify the several varieties of coal according to the relative percentages of carbon and volatile matter contained in their combustible portion as determined by proximate analysis. The following is the classification given in the author's "Steam-boiler Economy":

	Fixed Carbon.	Volatile Matter.	Heating Value per lb. of Combustible B.T.U.	Relative Value of Combustible. Semi-bit. = 100
Anthracite.....	97 to 90	3 to 10	14800 to 15400	93
Semi-anthracite.....	90 to 85	10 to 15	15400 to 15500	97
Semi-bituminous.....	85 to 70	15 to 30	15400 to 16000	100
Bituminous, Eastern..	70 to 55	30 to 45	14800 to 15600	96
Bituminous, Western .	65 to 50	35 to 50	12500 to 14800	90
Lignite.....	under 50	over 50	11000 to 13500	77

The anthracites, with some unimportant exceptions, are confined to three small fields in eastern Pennsylvania. The semi-anthracites are found in a few small areas in the western part of the anthracite field. The semi-bituminous coals are found on the eastern border of the great Appalachian coal field, extending from north central Pennsylvania across the southern boundary of Virginia into Tennessee, a distance of over 300 miles. They include the coals of Clearfield, Cambria, and Somerset counties, Pennsylvania, and the Cumberland, Md., the Pocahontas, Va., and the New River, W. Va., coals.

It is a peculiarity of the semi-bituminous coals that their combustible portion is of remarkably uniform composition, the volatile matter usually ranging between 18 and 22% of the combustible, and approaching in its analysis marsh gas, CH<sub>4</sub>, with very little oxygen. They are usually low also in moisture, ash, and sulphur, and rank among the best steaming coals in the world.

The eastern bituminous coals occupy the remainder of the Appalachian coal field, from Pennsylvania and eastern Ohio to Alabama. They are higher in volatile matter, ranging from 30 to over 40%, the higher figures in the western portion of the field. The volatile matter is of lower heating value, being higher in oxygen. The western bituminous coals are found in most of the states west of Ohio. They are higher in volatile matter and in oxygen and moisture than the bituminous coals of the Appalachian field, and usually give off a denser smoke when burned in ordinary furnaces.

A later classification by the author (*Trans. A. S. M. E.*, 1914; "Steam-boiler Economy," 2d edition, 1915) is given in the table below. It divides the bituminous coals into three grades, high, medium and low, the chief distinction between them being the percentage of moisture found in the coal after it is air-dried. The coals highest in inherent moisture are also highest in oxygen.

Classes: I. Anthracite. II. Semi-anthracite. III. Semi-bituminous. IV. Cannel. V. Bituminous, high grade. VI. Bituminous, medium grade. VII. Bituminous, low grade. VIII. Sub-bituminous and lignite.

Class.	Volatile Matter, % of Combustible.	Oxygen in Combustible Per Cent.	Moisture in Air-dry, Ash-free Coal, %	B.T.U. per lb. Combustible.	B.T.U. per lb. Air-dry, Ash-free Coal
I	less than 10	1 to 4	less than 1.8	14,800 to 15,400	14,600 to 15,400
II	10 to 15	1 to 5	less than 1.8	15,400 to 15,500	15,200 to 15,500
III	15 to 30	1 to 6	less than 1.8	15,400 to 16,050	15,300 to 16,000
IV*	45 to 60	5 to 8	less than 1.8	15,700 to 16,200	15,500 to 16,050
V	30 to 45	5 to 14	1 to 4	14,800 to 15,600	14,350 to 14,400
VI	32 to 50	6 to 14	2.5 to 6.5	13,800 to 15,100	11,300 to 14,400
VII	32 to 50	7 to 14	5 to 12	12,400 to 14,600	11,300 to 13,400
VIII	27 to 60	10 to 33	7 to 26	9,600 to 13,250	7,400 to 11,650

\* Eastern cancell. The Utah cancell is much lower in heating value.

The U. S. Geological Survey classifies coals into six groups, as follows: (1) anthracite; (2) semi-anthracite; (3) semi-bituminous; (4) bituminous; (5) sub-bituminous, or black lignite; and (6) lignite.

Classes 5 and 6 are described as follows:

Sub-bituminous coal is commonly known as "lignite," "lignitic coal," "black lignite," "brown coal," etc. It is generally black and shining, closely resembling bituminous coal, but it weathers more rapidly on exposure and lacks the prismatic structure of bituminous coal. Its calorific value is generally less than that of bituminous coal. The localities in which this sub-bituminous coal is found include Montana, Idaho, Washington, Oregon, California, Wyoming, Utah, Colorado, New Mexico, and Texas.

Lignite is commonly known as "lignite," "brown lignite," or "brown coal." It usually has a woody structure and is distinctly brown in color, even on a fresh fracture. It carries a higher percentage of moisture than any other class of coals, its mine samples showing from 30 to 40% of moisture. The localities in which lignite is found are chiefly North Dakota, South Dakota, Texas, Arkansas, Louisiana, Mississippi, and Alabama.

The following analyses of representative coals of the six classes are given by Prof. N. W. Lord:

Class 1 — Anthracite Culm. Penna.

Class 2 — Semi-anthracite. Arkansas.

Class 3 — Semi-bituminous. W. Va.

Class 4(a) — Bituminous coking. Connellsville, Pa.

Class 4(b) — Bituminous non-coking. Hocking Valley, Ohio.

Class 5 — Sub-bituminous. Wyoming, black lignite.

Class 6 — Lignite. Texas.

COMPOSITION OF ILLUSTRATIVE COALS—CAR-LOAD SAMPLES.

Proximate Analysis of "Air-dried" Sample.

Class.....	1	2	3	4a	4b	5	6
Moisture.....	2.08	1.28	0.65	0.97	7.55	8.68	9.88
Vol. comb.....	7.27	12.82	18.80	29.09	34.03	41.31	36.17
Fixed carbon.....	74.32	73.69	75.92	60.85	52.57	46.49	43.65
Ash.....	16.33	12.21	4.63	9.09	5.85	3.52	10.30
Loss on air-drying .	3.40	1.10	1.10	4.20	Undet.	11.30	23.50

Ultimate Analysis of Coal Dried at 105° C.

Hydrogen.....	2.63	3.63	4.54	4.57	5.06	5.31	4.47
Carbon.....	76.86	78.32	86.47	77.10	75.82	73.31	64.84
Oxygen.....	2.27	2.25	2.68	6.67	10.47	15.72	16.52
Nitrogen.....	0.82	1.41	1.08	1.58	1.50	1.21	1.30
Sulphur.....	0.78	2.03	0.57	0.90	0.82	0.60	1.44
Ash.....	16.64	12.36	4.66	9.18	6.33	3.85	11.43

Results Calculated to an Ash and Moisture-Free Basis.

Volatile comb.....	8.91	14.82	19.85	32.34	39.30	47.05	45.31
Fixed carbon.....	91.09	85.18	80.15	67.66	60.70	52.95	54.69

Ultimate Analysis.

Hydrogen.....	3.16	4.14	4.76	5.03	5.41	5.50	5.05
Carbon.....	92.20	89.36	90.70	84.89	80.93	76.35	73.21
Oxygen.....	2.72	2.57	2.81	7.34	11.18	16.28	18.65
Nitrogen.....	0.98	1.61	1.13	1.74	1.61	1.25	1.47
Sulphur.....	0.94	2.32	0.60	1.00	0.87	0.62	1.62

Calorific Value in B.T.U. per lb., by Dulong's formula.

Air-dried coal.....	12,472	13,406	15,190	13,951	12,510	11,620	10,288
Combustible.....	15,286	15,496	16,037	15,511	14,446	13,235	12,889

**Caking and Non-caking Coals.** — Bituminous coals are sometimes classified as caking and non-caking coals, according to their behavior when subjected to the process of coking. The former undergo an incipient fusion or softening when heated, so that the fragments coalesce and yield a compact coke, while the latter (also called free-burning) preserve their form, producing a coke which is only serviceable when made from



large pieces of coal, the smaller pieces being incoherent. The reason of this difference is not clearly understood, as non-caking coals are often of similar ultimate chemical composition to caking coals. Some coals which cannot be made into coke in a bee-hive oven are easily coked in gas-heated ovens.

**Cannel Coals** are coals that are higher in hydrogen than ordinary coals. They are valuable as enrichers in gas-making. The following are some ultimate analyses:

	C.	H.	O+N.	S.	Ash.	Combustible.		
						C.	H.	O+N.
Boghead, Scotland.....	63.10	8.91	7.25	0.96	19.78	79.61	11.24	9.15
Albertite, Nova Scotia..	82.67	9.14	8.19	.....	.....	82.67	9.14	8.19
Tasmanite, Tasmania...	79.34	10.41	4.93	5.32	.....	83.80	10.99	5.21

**Rhode Island Graphitic Anthracite.** — A peculiar variety of coal is found in the central part of Rhode Island and in Eastern Massachusetts. It resembles both graphite and anthracite coal, and has about the following composition (A. E. Hunt, *Trans. A. I. M. E.*, xvii. 678: Graphitic carbon, 78%; volatile matter, 2.60%; silica, 15.06%; phosphorus, .045%. It burns with extreme difficulty.

**ANALYSIS AND HEATING VALUE OF COALS.**

Coal is composed of four different things, which may be separated by proximate analysis, viz.: fixed carbon, volatile hydrocarbon, ash and moisture. In making a proximate analysis of a weighed quantity, such as a gram of coal, the moisture is first driven off by heating it to about 250° F. then the volatile matter is driven off by heating it in a closed crucible to a red heat, then the carbon is burned out of the remaining coke at a white heat, with sufficient air supplied, until nothing is left but the ash.

The fixed carbon has a constant heating value of about 14,600 B.T.U. per lb. The value of the volatile hydrocarbon depends on its composition, and that depends chiefly on the district in which the coal is mined. It may be as high as 21,000 B.T.U. per lb., or about the heating value of marsh gas, in the best semi-bituminous coals, which contain very small percentages of oxygen, or as low as 12,000 B.T.U. per lb., as in those from some of the western states, which are high in oxygen. The ash has no heating value, and the moisture has in effect less than none, for its evaporation and the superheating of the steam made from it to the temperature of the chimney gases, absorb some of the heat generated by the combustion of the fixed carbon and volatile matter.

The analysis of a coal may be reported in three different forms, as percentages of the moist coal, of the dry coal or of the combustible, as in the following table. By "combustible" is always meant the sum of the fixed carbon and volatile matter, the moisture and ash being excluded. By some-writers it is called "coal dry and free from ash" and by others "pure coal."

	Moist Coal.	Dry Coal.	Combustible.
Moisture.....	10	.....	.....
Volatile matter.....	30	33.33	37.50
Fixed carbon.....	50	55.56	62.50
Ash.....	10	11.11	.....
	100	100.00	100.00

The sulphur, commonly reported with a proximate analysis, is determined separately. In the proximate analysis part of it escapes with the volatile matter and the rest of it is found in the ash as sulphide of iron. The sulphur should be given separately in the report of the analysis.

The relation of the volatile matter and of the fixed carbon in the combustible portion of the coal enables us to judge the class to which the coal belongs, as anthracite, semi-anthracite, semi-bituminous, bituminous,

or lignite. Coals containing less than 10 per cent volatile matter in the combustible would be classed as anthracite, between 10 and 15 per cent as semi-anthracite, between 15 and 30 per cent as semi-bituminous, between 30 and 50 per cent as bituminous, and over 50 per cent as lignitic coals or lignites. In the classification of the U. S. Geological Survey the sub-bituminous coals and lignites are distinguished by their structure and color rather than by analysis.

The figures in the second column, representing the percentages in the dry coal, are useful in comparing different lots of coal of one class, and they are better for this purpose than the figures in the first column, for the moisture is a variable constituent, depending to a large extent on the weather to which the coal has been subjected since it was mined, on the amount of moisture in the atmosphere at the time when it is analyzed, and on the extent to which it may have accidentally been dried during the process of sampling.

The heating value of a coal depends on its percentage of total combustible matter, and on the heating value per pound of that combustible. The latter differs in different districts and bears a relation to the percentage of volatile matter. It is highest in the semi-bituminous coals, being nearly constant at about 15,750 B.T.U. per pound. It is between 14,800 and 15,500 B.T.U. in anthracite, and ranges from 15,500 down to 13,000 in the bituminous coals, decreasing usually as we go westward, and as the volatile matter contains an increasing percentage of oxygen. In some lignites it is as low as 10,000.

In reporting the heating value of a coal, the B.T.U. per pound of combustible should always be stated, for convenient comparison with other reports.

In 1892 the author deduced from Mahler's tests on European coals the following table of the approximate heating value of coals of different composition.

APPROXIMATE HEATING VALUES OF COALS.

Per Cent Volatile Matter in Coal Dry and Free from Ash.	Heating Value, B.T.U. per lb. Combustible.	Equivalent Water Evaporation from and at 212° per lb. Combustible.	Per Cent Volatile Matter in Coal Dry and Free from Ash.	Heating Value, B.T.U. per lb. Combustible.	Equivalent Water Evaporation from and at 212° per lb. Combustible.
0	14,580	15.09	32	15,480	16.03
3	14,940	15.47	37	15,120	15.65
6	15,210	15.75	40	14,760	15.28
10	15,480	16.03	43	14,220	14.72
13	15,660	16.21	45	13,860	14.35
20	15,840	16.40	47	13,320	13.79
28	15,660	16.21	49	12,420	12.86

The experiments of Lord and Haas on American coals (*Trans. A.I.M.E.*, 1897) practically confirm these figures for all coals in which the percentage of fixed carbon is 60% and over of the combustible, but for coals containing less than 60% fixed carbon or more than 40% volatile matter in the combustible, they are liable to an error in either direction of about 4%. It appears from these experiments that the coal of one seam in a given district has the same heating value per pound of combustible within one or two per cent [true only of some districts], but coals of the same proximate analysis, and containing over 40% volatile matter, but mined in different districts, may vary 6 or 8% in heating value.

The coals containing from 72 to 87 per cent of fixed carbon in the combustible have practically the same heating value. This is confirmed by Lord and Haas's tests of Pocahontas coal. A study of these tests and of Mahler's indicates that the heating value of all the semi-bituminous coals, 75 to 87.5% fixed carbon, is within 1½% of 15,750 B.T.U. per pound.

The heating value of any coal may also be calculated from its ultimate analysis, with a probable error not exceeding 2%, by Dulong's formula:

$$\text{Heating value per lb.} = 146 C + 620 \left( H - \frac{O}{8} \right) + 40 S$$

in which C, H, S, and O are respectively the percentages of carbon, hydrogen, sulphur and oxygen. Its approximate accuracy is proved by both Mahler's and Lord and Haas's experiments, and any deviation of the calorimetric determination of any coals (cannel coals and lignites excepted) more than 2% from that calculated by the formula, is more likely to proceed from an error in either the calorimetric test or the analysis, than from an error in the formula.

**Average Results of Lord and Haas's Tests.**—("Steam Boiler Economy," p. 156.)

Name of Coal.	C.	H.	O.	N.	S.	Ash.	Moist.	Vol. Mat.	Fixed C.	Vol. Mat. % of Comb.	B.T.U.*
Pocahontas, Va.	84.87	4.20	2.84	0.85	0.59	5.89	0.76	18.51	74.84	19.82	15766
Thacker, W. Va.	78.65	5.00	6.01	1.41	1.28	6.27	1.38	35.68	56.67	38.62	15237
Pittsburg, Pa. . . .	75.24	5.01	7.04	1.51	1.79	8.02	1.37	36.80	53.81	40.61	14963
Middle Kittanning, Pa. . . . .	75.19	4.91	7.47	1.46	1.98	7.18	1.81	36.32	54.69	39.91	14800
Upper Freeport, Pa. and O. . . . .	72.65	4.82	7.26	1.34	2.89	9.10	1.93	37.35	51.63	41.98	14755
Mahoning, O. . . . .	71.13	4.56	7.17	1.23	1.86	10.90	3.15	35.00	50.95	40.72	14728
Jackson Co., O. . . . .	70.72	4.45	10.82	1.47	1.13	3.25	8.17	35.79	52.78	40.41	14141
Hocking Valley, O. . . . .	68.03	4.97	9.87	1.44	1.59	8.00	6.59	35.77	49.64	41.84	14040

\* Per lb. of combustible, by the Mahler calorimeter. The average figures calculated from the ultimate analyses agreed within 0.5%, except in the case of the Jackson Co. coal, in which the calorimetric result was 1.6% higher than that computed from the analysis.

**Sizes of Anthracite Coal.**—When anthracite is mined it is crushed in a "breaker," and passed over screens separating it into different sizes, which are named as follows:

Lump, passes over bars set 3 1/2 to 5 in. apart; steamboat, over 3 1/2 in. and out of screen; broken, through 4 1/2 in., over 3 1/4 in.; egg, 3 1/4 to 2 5/16 in.; stove, 2 5/16 to 1 5/8 in.; chestnut, 1 5/8 to 7/8 in.; pea, 7/8 to 9/16 in.; buckwheat, No. 1, 9/16 to 5/16 in.; No. 2, 5/16 to 3/16; No. 3, 3/16 to 3/32 in.; culm, through 3/32 in.

The terms "buckwheat," "rice" and "barley" are used in some localities instead of No. 1, No. 2 and No. 3 buckwheat.

When coal is screened into sizes for shipment the purity of the different sizes as regards ash varies greatly. Samples from one mine gave results as follows:

Name of Coal.	Screened.		Analyses.	
	Through Inches.	Over Inches.	Fixed Carbon.	Ash.
Egg. . . . .	2.5	1.75	88.49	5.66
Stove. . . . .	1.75	1.25	83.67	10.17
Chestnut. . . . .	1.25	0.75	80.72	12.67
Pea. . . . .	0.75	0.50	79.05	14.66
Buckwheat . . . . .	0.50	0.25	76.92	16.62

**Space Occupied by Anthracite Coal.** (*J. C. I. W.*, vol. iii.)—The cubic contents of 2240 lb. of hard Lehigh coal is a little over 36 feet; an average Schuylkill white-ash, 37 to 38 feet; Shamokin, 38 to 39 feet; Lorberry, nearly 41.

According to measurements made with Wilkes-Barre anthracite coal from the Wyoming Valley, it requires 32.2 cu. ft. of lump, 33.9 cu. ft.



broken, 34.5 cu. ft. egg, 34.8 cu. ft. of stove, 35.7 cu. ft. of chestnut, and 36.7 cu. ft. of pea, to make one ton of coal of 2240 lb.; while it requires 28.8 cu. ft. of lump, 30.3 cu. ft. of broken, 30.8 cu. ft. of egg, 31.1 cu. ft. of stove, 31.9 cu. ft. of chestnut, or 32.8 cu. ft. of pea, for one ton (2000 lb.)

#### Bernice Basin, Pa., Coals.

	Water	Vol.	H.C.	Fixed C.	Ash.	Sulphur.
Bernice Basin, Sullivan } and Lycoming Cos.; } range of 8. . . . . }	0.96 to 1.97	3.56 to 8.56		82.52 to 89.39	3.27 to 9.34	0.24 to 1.04

This coal is on the dividing-line between the anthracites and semi-anthracites, and is similar to the coal of the Lykens Valley district.

More recent analyses (*Trans. A. I. M. E.*, xiv. 721) give:

	Water	Vol.	H.C.	Fixed C.	Ash.	Sulphur
Working seam. . . . .	0.65	9.40		83.69	5.34	0.91
60 ft. below seam. . . . .	3.67	15.42		71.34	8.97	0.59

The first is a semi-anthracite, the second a semi-bituminous.

**Connellsville Coal and Coke.** (*Trans. A. I. M. E.*, xiii. 332.)—The Connellsville coal-field, in the southwestern part of Pennsylvania, is a strip about 3 miles wide and 60 miles in length. The mine workings are confined to the Pittsburgh seam, which here has its best development as to size, and its quality best adapted to coke-making. It generally affords from 7 to 8 feet of coal.

The following analyses by T. T. Morrell show about its range of composition:

	Moisture.	Vol. Mat.	Fixed C.	Ash.	Sulphur.	Phosph's.
Herold Mine	1.26	28.83	60.79	8.44	0.67	0.013
Kintz Mine.	0.79	31.91	56.46	9.52	1.32	0.02

In comparing the composition of coals across the Appalachian field, in the western section of Pennsylvania, it will be noted that the Connellsville variety occupies a peculiar position between the rather dry semi-bituminous coals eastward of it and the fat bituminous coals flanking it on the west.

**Indiana Coals.** (J. S. Alexander, *Trans. A. I. M. E.*, iv. 100.)—The typical block coal of the Brazil (Indiana) district differs in chemical composition but little from the coking coals of Western Pennsylvania. The physical difference, however, is quite marked; the latter has a cuboid structure made up of bituminous particles lying against each other, so that under the action of heat fusion throughout the mass readily takes place, while block coal is formed of alternate layers of rich bituminous matter and a charcoal-like substance, which is not only very slow of combustion, but so retards the transmission of heat that agglutination is prevented, and the coal burns away layer by layer, retaining its form until consumed.

**Illinois Coals.** The Illinois coals are generally high in moisture, volatile matter, ash and sulphur, and the volatile matter is high in oxygen; consequently the coals are low in heating value. The range of quality is a wide one. The Big Muddy coal of Jackson Co., which has a high reputation as a steam coal in the St. Louis market, has about 36% of volatile matter in the combustible, while a coal from Staunton, Macoupin Co., tested by the author in 1883 (*Trans. A. S. M. E.*, v. 266) had 68%. A boiler test with this coal gave only 6.19 lbs. of water evaporated from and at 212° per lb. of combustible, in the same boiler that had given 9.88 lbs. with Jackson, O., nut.

Prof. S. W. Parr, in Bulletin No. 3 of the Ill. State Geol. Survey, 1906, reports the analyses and calorimetric tests of 150 Illinois coals. The two having the lowest and the highest value per pound of combustible have the following analysis:

	Air-dried Coal.					Pure Coal.		
	Moist.	Ash.	Vol.	Fixed C.	S.	Vol.	Fixed C.	B.T.U. per lb.
Lowest..	9.90	5.02	40.75	44.33	2.00	47.90	52.10	12,162
Highest.	5.68	8.90	33.32	52.10	1.18	39.02	60.98	14,830

The poorest coal of the series had a heating value of only 8645 B.T.U.

per lb., air dry; it contained 9.70 moisture and 31.18 ash, and the B.T.U. per lb. combustible was 14,623. The best coal had a heating value of 13,303 per lb.; moisture 4.20, ash 5.50, B.T.U. per lb. combustible, 14,734.

Of the 150 coals, 28 gave between 14,500 and 14,830 B.T.U. per lb. combustible; 82 between 14,000 and 14,500; 32 between 13,500 and 14,000; 6 between 13,000 and 13,500; one 12,535 and one 12,162. The average is about 14,200. The volatile matter ranged from 36.24% to 53.80% of the combustible; the sulphur from 0.62 to 4.96%; the ash from 2.32 to 31.18%, and the moisture from 3.28 to 12.74%, all calculated from the air-dried samples. The moisture in the coal as mined is not stated, but was no doubt considerably higher. The author has found over 14% moisture in a lump of Illinois coal that was apparently dry, having been exposed to air, under cover, for more than a month.

**Colorado Coals.**—The Colorado coals are of extremely variable composition, ranging all the way from lignite to anthracite. G. C. Hewitt (*Trans. A. I. M. E.*, xvii. 377) says: The coal seams, where unchanged by heat and flexure, carry a lignite containing from 5% to 20% of water. In the southeastern corner of the field the seams have been metamorphosed so that in four miles the same seams are an anthracite, coking, and dry coal. The dry seams also present wide chemical and physical changes in short distances. A soft and loosely bedded coal has in a hundred feet become compact and hard without the intervention of a fault. A couple of hundred feet has reduced the water of combination from 12% to 5%.

**Western Arkansas and Oklahoma (formerly Indian Territory).** (H. M. Chance, *Trans. A. I. M. E.*, 1890.)—The western Arkansas coals are dry semi-bituminous or semi-anthracitic coals, mostly non-coking, or with quite feeble coking properties, ranging from 14% to 16% in volatile matter, the highest percentage yet found, according to Mr. Winslow's Arkansas report, being 17.65.

In the Mitchell basin, about 10 miles west from the Arkansas line, the coal shows 19% volatile matter; the Mayberry coal, about 8 miles farther west, contains 23%; and the Bryan Mine coal, about the same distance west, shows 26%. About 30 miles farther west, the coal shows from 38% to 41.5% volatile matter, which is also about the percentage in coals of the McAlester and Lehigh districts.

**Analyses of Foreign Coals.** (Selected from D. L. Barnes's paper on American Locomotive Practice, *Trans. A. S. C. E.*, 1893.)

	Volatile Matter.	Fixed Carbon.	Ash.		Volatile Matter.	Fixed Carbon.	Ash.
Great Britain:				South America:			
South-Wales....	8.5	88.3	3.2	Chili, Chiroqui..	24.11	38.98	36.91
South-Wales....	6.2	92.3	1.5	Patagonia.....	24.35	62.25	13.4
Lancashire, Eng.	17.2	80.1	2.7	Brazil.....	40.5	57.9	1.6
Derbyshire, .....	17.7	79.9	2.4	Canada:			
Durham, " * .....	15.05	86.8	1.1	Nova Scotia....	26.8	60.7	12.5
Staffordshire, " .....	20.4	78.6	1.0	Cape Breton....	26.9	67.6	5.5
Scotland†.....	17.1	63.1	19.8	Australia:			
Scotland‡.....	17.5	80.1	2.4	Lignite.....	15.8	64.3	10.0
South America:				Sydney, N.S.W..	14.98	82.39	2.04
Chili.....	21.93	70.55	7.52	Borneo.....	26.5	70.3	14.2
				Tasmania.....	6.16	63.4	30.45

\* Semi-bit, coking coal.

† Boghead cannel gas coal.

‡ Semi-bit, steam-coal.

An analysis of Pictou, N. S., coal, in *Trans. A. I. M. E.*, xiv. 560, is: vol., 29.63; carbon, 56.98; ash, 13.39; and one of Sydney, Cape Breton, coal is: vol., 34.07; carbon, 61.43; ash, 4.50.

**Sampling Coal for Analysis.**—J. P. Kimball, *Trans. A. I. M. E.*, xii. 317, says: The unsuitable sampling of a coal-seam, or the improper preparation of the sample in the laboratory, often gives rise to errors in

determinations of the ash so wide in range as to vitiate the analysis for all practical purposes; every other single determination, excepting moisture, showing its relative part of the error. The determinations of sulphur and ash are especially liable to error, as they are intimately associated in the slates.

Wm. Forsyth, in his paper on *The Heating Value of Western Coals* (*Eng'g News*, Jan. 17, 1895), says: This trouble in getting a fairly average sample of anthracite coal has compelled the Reading R. R. Co., in getting its samples, to take as much as 300 lb. for one sample, drawn direct from the chutes, as it stands ready for shipment.

The directions for collecting samples of coal for analysis at the C., B. & Q. laboratory are as follows:

Two samples should be taken, one marked "average," the other "select." Each sample should contain about 10 lb., made up of lumps about the size of an orange taken from different parts of the dump or car, and so selected that they shall represent as nearly as possible, first, the average lot; second, the best coal.

An example of the difference between an "average" and a "select" sample, taken from Mr. Forsyth's paper, is the following of an Illinois coal:

	Moisture.	Vol. Mat.	Fixed Carbon.	Ash.
Average.....	1.36	27.69	35.41	35.54
Select.....	1.90	34.70	48.23	15.17

The theoretical evaporative power of the former was 9.13 lbs. of water from and at 212° per lb. of coal, and that of the latter 11.44 lbs.

For methods of sampling see Kent's "Steam Boiler Economy," 2d edition (1915), also Report of the Power Test Committee, *A. S. M. E.*, 1915, and Technical Paper No. 8 of the U. S. Bureau of Mines, 1913.

### RELATIVE VALUE OF STEAM COALS.

The heating value of a coal may be determined, with more or less approximation to accuracy, by three different methods.

1st, by chemical analysis; 2d, by combustion in a coal calorimeter; 3d, by actual trial in a steam-boiler.

The accuracy of the first two methods depends on the precision of the method of analysis or calorimetry adopted, and upon the care and skill of the operator. The results of the third method are subject to numerous sources of variation and error, and may be taken as approximately true only for the particular conditions under which the test is made. Analysis and calorimetry give with considerable accuracy the heating value which may be obtained under the conditions of perfect combustion and complete absorption of the heat produced. A boiler test gives the actual result under conditions of more or less imperfect combustion, and of numerous and variable wastes. It may give the highest practical heating value, if the conditions of grate-bars, draft, extent of heating surface, method of firing, etc., are the best possible for the particular coal tested, and it may give results far beneath the highest if these conditions are adverse or unsuitable to the coal.

In a paper entitled *Proposed Apparatus for Determining the Heating Power of Different Coals* (*Trans. A. I. M. E.*, xiv. 727) the author described and illustrated an apparatus designed to test fuel on a large scale, avoiding the errors of a steam-boiler test. It consists of a fire-brick furnace enclosed in a water casing, and two cylindrical shells containing a great number of tubes, which are surrounded by cooling water and through which the gases of combustion pass while being cooled. No steam is generated in the apparatus, but water is passed through it and allowed to escape at a temperature below 200° F. The product of the weight of the water passed through the apparatus by its increase in temperature is the measure of the heating value of the fuel.

A study of M. Mahler's calorimetric tests shows that the maximum difference between the results of these tests and the calculated heating power by Dulong's law in any single case is only a little over 3%, and the results of 31 tests show that Dulong's formula gives an average of only 47 thermal units less than the calorimetric tests, the



average total heating value being over 14,000 B.T.U., a difference of less than 0.4%.\*

The close agreement of the results of calorimetric tests when properly conducted, and of the heating power calculated from the ultimate chemical analysis indicates that either the chemical or the calorimetric method may be accepted as correct enough for all practical purposes for determining the total heating power of coal. The results obtained by either method may be taken as a standard by which the results of a boiler test are to be compared, and the difference between the total heating power and the result of the boiler test is a measure of the inefficiency of the boiler under the conditions of any particular test.

The heating value that can be obtained in boiler practice from any given coal depends upon the efficiency of the boiler, and this largely upon the difficulty of thoroughly burning the volatile combustible matter in the boiler furnace.

With the best anthracite coal, in which the combustible portion is, say, 97% fixed carbon and 3% volatile matter, the highest result that can be expected in a boiler-test with all conditions favorable is 12.2 lb. of water evaporated from and at 212° per lb. of combustible, which is 79% of 15.47 lb., the theoretical heating-power. With the best semibituminous coals, such as Cumberland and Pocahontas, in which the fixed carbon is 80% of the total combustible, 12.5 lb., or 76% of the theoretical 16.4 lb., may be obtained. For Pittsburgh coal, with a fixed carbon ratio of 68%, 11 lb., or 69% of the theoretical 16.03 lb., is about the best practically obtainable with the best boilers when hand-fired, with ordinary furnaces. (The author has obtained 78% with an automatic stoker set in a "Dutch oven" furnace.) With some good Ohio coals, with a fixed carbon ratio of 60%, 10 lb., or 66% of the theoretical 15.28 lb., has been obtained, under favorable conditions, with a fire-brick arch over the furnace. With coals mined west of Ohio, with lower carbon ratios, the boiler efficiency is not apt to be as high as 60% unless a special furnace, adapted to the coal, is used.

From these figures a table of probable maximum boiler-test results with ordinary furnaces from coals of different fixed carbon ratios may be constructed as follows:

Fixed carbon ratio . . . . .	97	80	68	60	54	50
Evap. from and at 212° per lb. combustible, maximum in boiler-tests:	12.2	12.5	11	10	8.3	7.0
Boiler efficiency, per cent. . . . .	80	76	69	66	60	55
Loss, chimney, radiation, imperfect combustion, etc.:	20	24	31	34	40	45

The difference between the loss of 20% with anthracite and the greater losses with the other coals is chiefly due to imperfect combustion of the bituminous coals, the more highly volatile coals sending up the chimney the greater quantity of smoke and unburned hydrocarbon gases. It is a measure of the inefficiency of the boiler furnace and of the inefficiency of heating-surface caused by the deposition of soot, the latter being primarily caused by the imperfection of the ordinary furnace and its unsuitability to the proper burning of bituminous coal. If in a boiler-test with an ordinary furnace lower results are obtained than those in the above table, it is an indication of unfavorable conditions, such as bad firing, wrong proportions of boiler, defective draft, a rate of driving beyond the capacity of the furnace, or beyond the capacity of the boiler to absorb the heat produced in the furnace. It is quite possible, however, with automatic stokers and fire-brick combustion chambers to obtain an efficiency of 70% with the highly volatile western coals.

Under exceptionally good conditions, with mechanical stokers, very large combustion chambers, and the air supply controlled according to the indications of gas analyses, as high as 81% efficiency has been obtained. See under Steam-Boilers, page 898.

\* The formula commonly used in the United States is  $14,600 C + 62,000 (H - 1/8O) + 4050 S$ . For a description of the Mahler calorimeter and its method of operation see the author's "Steam Boiler Economy." Prof. S. W. Parr, of the University of Illinois, has put a calorimeter on the market which gives results practically equal to those obtained with Mahler's instrument.

## Classified List of Coals.

	As Received.			Combustible.				Air-dry, Ash-free	
	Moist.	Ash.	B.T.U.	Vol.	S.	O.	B.T.U.	Moist.	B.T.U.
I. ANTHRACITE.									
Alaska.	7.43	14.36	11,891	8.8	0.73	4.04	15,203	1.55	14,968
Colo...	2.70	5.83	14,099	3.6	0.87	1.32	15,413	1.08	15,247
Pa.....	2.80	7.83	13,298	1.3	1.00	2.13	14,882	1.43	14,666
Pa.....	3.30	9.12	13,351	3.7	0.68	2.41	15,248	0.83	15,123
Wash...	.....	.....	.....	8.5	0.72	2.67	15,410	0.80	15,367
II. SEMI-ANTHRACITE.									
Ark....	2.36	12.08	13,259	14.8	2.33	2.57	15,496	1.45	15,272
Pa.....	3.38	11.50	13,156	10.0	0.74	2.17	15,457	0.91	15,398
Va....	4.80	18.03	11,961	13.1	0.82	4.18	15,500	0.90	15,439
III. SEMI-BITUMINOUS.									
Ala....	3.08	3.75	14,681	28.8	0.59	4.45	15,757	1.15	15,577
Ala....	2.38	4.88	14,487	27.9	1.58	3.42	15,620	0.94	15,475
Alaska.	5.14	5.00	14,065	15.5	1.29	3.02	15,651	0.60	15,559
Ark....	2.77	9.07	13,774	16.7	3.16	1.69	15,624	0.86	15,525
Ark....	3.21	9.29	13,588	17.0	3.57	1.25	15,530	0.92	15,387
Colo...	0.96	8.62	14,330	23.8	0.58	4.34	15,849	0.83	15,716
Colo...	3.07	9.16	13,990	25.8	0.72	2.29	15,939	1.43	15,712
Ga....	3.80	14.49	12,791	19.4	1.55	5.96	15,653	0.74	15,540
Md....	3.20	6.70	14,100	16.0	1.02	2.54	15,640	1.10	15,478
Md....	2.60	6.80	14,360	17.5	0.98	2.47	15,856	0.66	15,746
Mont..	2.05	8.31	14,092	18.3	0.96	2.93	15,721	0.61	15,625
Okla...	2.37	8.83	13,840	21.7	1.15	2.87	15,586	0.53	15,504
Okla...	5.11	8.03	13,662	15.7	1.36	1.87	15,728	0.70	15,619
Pa.....	4.25	7.87	13,513	24.8	1.81	5.50	15,376	0.40	15,316
Pa.....	1.10	7.41	14,499	17.3	1.63	2.82	15,847	0.65	15,744
Va....	4.00	4.31	14,520	19.0	0.68	3.42	15,840	0.54	15,750
Va....	4.10	3.18	14,740	17.5	0.68	2.23	15,910	0.64	15,795
Wash..	5.81	17.04	11,776	16.3	0.48	3.97	15,264	1.67	15,013
W.Va..	3.71	3.39	14,306	25.3	0.86	4.13	15,399	1.18	15,218
W.Va..	1.75	4.58	15,023	19.9	0.60	2.80	16,038	0.69	15,998
IV. CANNEL.*									
Ky....	2.36	10.49	13,770	55.5	1.38	7.57	15,800	0.92	15,646
Ky....	1.70	9.31	14,251	57.0	1.15	7.61	16,013	1.44	15,784
W.Va..	1.80	3.44	15,330	47.4	0.92	5.34	16,176	0.84	16,042
Utah...	7.35	23.24	10,355	67.6	2.32	13.68	14,918	8.26	13,686
V. BITUMINOUS, HIGH-GRADE.									
Ala....	2.18	2.79	14,816	33.4	1.13	6.99	15,590	1.23	15,400
Ala....	3.83	5.48	13,799	35.3	1.07	7.00	15,214	1.77	14,947
Colo...	2.64	5.21	13,529	31.3	0.72	9.38	14,681	1.01	14,533
Colo...	2.28	9.16	13,781	33.7	0.56	8.77	15,559	0.87	15,423
Ill....	7.81	8.38	12,418	40.0	2.82	9.74	14,818	2.34	14,470
Kan....	2.50	12.45	12,900	39.8	6.68	5.26	15,167	2.86	14,734
Kan....	9.04	15.72	11,142	39.5	4.93	7.27	14,809	2.49	14,436
Ky....	3.41	5.73	13,928	35.3	0.58	8.05	15,328	1.64	15,095
N.Mex.	2.78	14.57	12,294	41.5	0.74	8.79	14,875	1.64	14,630
N.Mex.	2.45	17.40	12,200	34.4	0.96	6.93	15,221	0.80	15,099
Ohio...	3.53	9.12	13,072	42.9	3.97	7.04	14,965	2.38	14,642
Ohio...	5.59	8.29	12,773	42.8	3.66	9.01	14,832	3.83	14,431
Okla...	2.09	20.07	11,695	35.5	7.36	3.71	15,025	1.38	14,814
Okla...	2.81	8.75	13,320	40.8	2.06	7.35	15,061	1.57	14,825
Pa.....	2.61	6.17	13,997	38.3	1.38	6.94	15,345	1.42	15,127
Pa.....	5.13	8.71	13,365	32.4	1.00	7.35	15,511	1.07	15,346
Tenn...	6.39	9.53	12,578	38.4	1.17	7.94	14,960	1.97	14,665
Tenn...	3.89	14.43	12,514	33.8	0.95	6.70	15,320	1.08	15,137
Va....	4.44	5.98	13,363	40.2	0.85	12.18	14,918	2.52	14,381
Va....	3.31	3.76	14,209	35.3	0.97	5.65	15,291	1.49	15,069
Wash..	2.32	13.58	12,443	44.0	5.23	13.93	14,796	1.55	14,569
W.Va..	4.21	7.22	13,379	40.0	0.72	10.10	15,107	2.11	14,787
W.Va..	2.86	5.83	14,105	36.4	0.73	5.14	15,448	1.36	15,237
Wyo...	5.49	3.12	13,570	39.3	0.99	11.40	14,848	2.13	14,552

\* H in combustible: Ky., 7.13, and 7.46; W. Va., 7.13; Utah, 7.73. The highest H in the other coals is 5.78, a Missouri bituminous.

## Classified List of Coals.—Continued.

	As Received.			Combustible.				Air-dry, Ash-free	
	Moist.	Ash.	B.T.U.	Vol.	S.	O.	B.T.U.	Moist.	B.T.U.
VI. BITUMINOUS MEDIUM GRADE									
Ala. . . .	3.95	14.59	11,785	37.7	1.37	10.45	14,467	2.69	14,078
Alaska . .	7.06	21.78	9,846	44.2	1.83	14.11	13,838	2.55	13,484
Cal. . . .	6.95	6.23	12,447	53.8	4.80	11.47	14,336	5.19	13,593
Ill. . . . .	8.12	8.63	12,064	41.4	1.36	12.02	14,492	5.15	13,745
Ill. . . . .	8.86	11.66	11,702	39.3	3.10	9.03	14,724	3.71	14,177
Ind. . . . .	16.91	17.37	9,524	40.9	2.88	9.50	14,492	5.48	13,698
Ind. . . . .	7.88	14.20	11,146	47.3	6.60	9.96	14,305	5.01	13,576
Iowa. . . .	13.88	14.01	10,244	51.2	8.53	8.96	14,206	5.35	13,445
Iowa. . . .	8.24	16.00	11,027	40.6	6.64	8.03	14,555	6.24	13,647
Kan. . . . .	6.95	12.19	11,905	44.2	9.94	5.64	14,724	4.09	14,121
Kan. . . . .	2.50	12.45	12,900	39.8	5.22	5.98	14,922	4.30	14,269
Ky. . . . .	7.92	10.06	12,022	44.0	4.29	8.90	14,657	6.52	13,702
Ky. . . . .	5.27	14.18	11,950	43.5	5.64	7.46	14,836	2.98	14,394
Mich. . . .	11.91	6.84	11,781	38.8	1.53	9.54	14,499	4.70	13,818
Mich. . . .	11.55	3.25	12,442	37.1	1.11	10.51	14,603	5.59	13,786
Mo. . . . .	17.30	23.38	8,240	44.6	4.96	11.83	13,892	3.42	13,416
Mo. . . . .	12.67	4.83	12,487	50.2	6.21	6.12	15,134	5.68	14,276
Mont. . . .	3.51	19.50	10,881	34.3	4.86	9.50	14,134	2.42	13,791
Mont. . . .	5.77	10.57	12,281	39.6	0.60	9.77	14,681	2.30	14,342
N.Mex. . . .	5.02	12.00	12,064	44.3	0.68	12.70	14,539	3.06	14,093
Ohio. . . .	4.14	9.38	12,874	37.8	0.63	11.58	14,269	4.69	14,152
Ohio. . . .	7.71	11.95	11,515	47.7	5.74	9.44	14,332	3.30	13,523
Okla. . . .	7.04	10.01	12,202	41.7	2.31	9.26	14,711	4.31	14,075
Utah. . . .	5.58	8.99	12,170	45.6	0.60	13.30	14,245	4.98	13,536
Utah. . . .	6.05	4.87	13,151	47.2	0.62	10.93	14,764	2.47	14,399
Wash. . . .	6.02	19.35	10,708	41.8	0.57	12.38	14,348	3.26	13,879
Wyo. . . . .	3.96	4.77	13,502	39.6	0.84	9.25	14,793	2.73	14,391
VII. BITUMINOUS LOW GRADE.									
Alaska. . .	10.77	14.87	9,641	40.8	0.94	18.83	12,964	5.42	12,261
Ill. . . . .	11.35	13.40	10,733	46.0	6.33	10.53	14,263	6.75	13,300
Ill. . . . .	14.43	13.28	10,064	40.8	5.55	12.02	13,921	6.02	13,084
Ind. . . . .	12.11	6.83	11,952	42.2	1.78	10.55	14,746	9.60	13,329
Ind. . . . .	13.18	15.63	10,030	44.8	6.73	9.69	14,089	6.17	13,220
Iowa. . . .	14.08	10.96	10,723	47.5	5.69	9.73	14,305	11.33	12,684
Mo. . . . .	15.36	10.99	10,460	47.3	4.85	10.68	14,202	7.37	13,156
Mont. . . .	9.76	16.42	10,235	37.5	0.86	16.21	13,865	7.58	12,813
Mont. . . .	10.88	26.88	7,742	32.6	2.88	16.14	12,438	8.09	11,432
N.Mex. . . .	12.29	6.99	11,252	42.8	0.78	14.00	13,939	11.70	12,309*
N.Mex. . . .	15.79	9.37	9,970	46.8	2.38	15.69	13,322	7.87	12,008*
Okla. . . .	8.29	25.05	9,110	45.9	5.93	10.62	13,667	7.74	12,609
Ore. . . . .	.....	.....	.....	48.1	1.65	.....	14,618	11.88	12,882
Utah. . . .	10.35	9.62	10,874	45.4	7.27	10.05	13,586	9.65	12,276
Utah. . . .	14.19	9.92	9,927	44.0	7.10	14.18	13,081	11.47	11,374
Wash. . . .	12.05	10.41	10,414	47.5	0.44	17.11	13,423	6.56	12,548
VIII. SUB-BITUMINOUS AND LIGNITE.									
Ark. . . . .	39.43	9.71	6,356	52.1	0.96	21.17	12,497	22.00	9,750
Cal. . . . .	18.51	15.49	8,507	53.5	4.62	16.79	12,890	10.95	11,478
Colo. . . .	19.65	6.00	8,638	41.4	0.44	16.97	11,619	8.21	10,664
Colo. . . .	19.28	4.70	9,064	45.5	0.51	16.52	13,239	15.35	10,094
Mont. . . .	30.00	11.90	6,914	69.0	1.86	23.47	11,900	15.55	10,143
Mont. . . .	24.59	14.01	6,208	54.1	0.67	26.64	10,211	25.02	7,656
N.Dak. . . .	35.96	7.75	7,069	56.7	2.04	17.69	12,557	26.20	8,886
N.Dak. . . .	38.92	5.39	6,739	45.9	0.86	22.67	12,101	11.66	10,885
Ore. . . . .	16.10	13.17	9,031	44.0	1.15	19.68	12,769	10.16	11,471
Ore. . . . .	13.77	7.46	9,054	47.0	5.52	.....	11,493	7.05	10,684
S. Dak. . . .	30.45	12.15	6,944	40.0	0.68	.....	12,098	15.77	10,189
Tex. . . . .	34.70	11.20	7,056	59.6	1.46	18.99	13,043	15.73	11,077
Tex. . . . .	33.71	7.28	7,348	49.6	0.90	20.54	12,452	11.82	11,036

(Table continued on p. 830.)



## Classified List of Coals.—Continued.

	As Received.			Combustible.				Air-dry, Ash-free	
	Moist.	Ash.	B.T.U.	Vol.	S.	O.	B.T.U.	Moist.	B.T.U.
VIII. SUB-BITUMINOUS AND LIGNITE.—Continued.									
Utah...	16.59	13.44	7,882	46.6	4.88	22.14	11,264	15.35	9,535
Wash..	27.17	10.92	7,569	54.6	0.53	22.06	12,226	17.21	10,122
Wyo...	10.26	9.83	10,354	27.8	1.09	10.94	12,956	9.56	11,573
Wyo...	31.37	10.12	5,634	50.6	2.17	29.86	9,630	22.69	7,458†
NOT CLASSIFIED.‡									
R. I. . .	23.68	30.77	5,976	6.6	0.05	5.59	13,120	1.26	12,955
R. I. . .	2.41	19.06	10,996	6.3	0.09	3.27	14,002	0.52	13,930
Alaska..	5.71	34.15	8,386	21.7	10.76	5.28	13,945	4.77	13,279
Ark....	5.26	24.81	10,451	21.0	1.43	6.44	14,945	1.77	14,722
Idaho..	34.28	13.38	8,613	50.9	4.77	.....	16,457	16.42	13,757

\* These two samples are classed as sub-bituminous by the Bureau of Mines.

† Sample from surface exposure; coal badly weathered.

‡ The Rhode Island coals are graphitic and are not used as fuel. The two samples from Alaska and Arkansas may be classed as semi-bituminous by their percentage of volatile matter, but they are higher in oxygen and in moisture, and lower in heating value than other semi-bituminous coals. The Idaho coal is apparently a cannel coal very high in moisture, but the ultimate analysis is lacking.

**Purchase of Coal under Specifications.**—It is customary for large users of coal to purchase it under specifications of its analysis or heating value with a penalty attached for failure to meet the specifications. The following standards for a specification were given by the author in his "Steam Boiler Economy," 1901. (Revised in 2d edition, 1915):

*Anthracite and Semi-anthracite.*—The standard is a coal containing 5% volatile matter, not over 2% moisture, and not over 10% ash. A premium of 0.5% on the price will be given for each per cent of volatile matter above 5% up to and including 15%, and a reduction of 2% on the price will be made for each 1% of moisture and ash above the standard.

*Semi-bituminous and Bituminous.*—The standard is a semi-bituminous coal containing not over 20% volatile matter, 2% moisture, 6% ash. A reduction of 1% in the price will be made for each 1% of volatile matter in excess of 25%, and of 2% for each 1% of ash and moisture in excess of the standard.

For western coals in which the volatile matter differs greatly in its percentage of oxygen, the above specification based on proximate analysis may not be sufficiently accurate, and it is well to introduce either the heating value as determined by a calorimeter or the percentage of oxygen. The author has proposed the following for Illinois coal:

The standard is a coal containing not over 6% moisture and 10% ash in an air-dried sample, and whose heating value is 14,500 B.T.U. per pound of combustible. For lower heating value per lb. of the combustible, the price shall be reduced proportionately, and for each 1% increase in ash or moisture above the specified figures, 2% of the price shall be deducted.

Several departments of the U. S. government now purchase coal under specifications. See paper on the subject by D. T. Randall, Bulletin No. 339, U. S. Geological Survey, 1908, also "Steam Boiler Economy," 2d edition.

**Weathering of Coal.** (I. P. Kimball, *Trans. A. I. M. E.*, viii, 204.)—The effect of the weathering of coal, while sometimes increasing its weight, is to diminish the carbon and disposable hydrogen and to increase the oxygen and indisposable hydrogen. Hence a reduction in the calorific value. An excess of pyrites in coal tends to produce rapid oxidation and mechanical disintegration of the mass, with development of heat, loss of coking power, and spontaneous ignition.

The only appreciable results of the weathering of anthracite are con-

fined to the oxidation of its accessory pyrites. In coking coals, however, weathering reduces and finally destroys the coking power.

Richters found that at a temperature of 158° to 180° Fahr., three coals lost in fourteen days an average of 3.6% of calorific power. It appears from the experiments of Richters and Reder that when there is no rise of temperature of coal piled in heaps and exposed to the air for nine to twelve months, it undergoes no sensible change, but when the coal becomes heated it suffers loss of C and H by oxidation and increases in weight by the fixation of oxygen. (See also paper by R. P. Rothwell, *Trans. A. I. M. E.*, iv. 55.)

Experiments by S. W. Parr and N. D. Hamilton (Bull. No. 17 of Univ'y of Ill. Eng'g Experiment Station, 1907) on samples of about 100 lb. each, show that no appreciable change takes place in coal submerged in water. Their conclusions are:

- (a) Submerged coal does not lose appreciably in heat value.
- (b) Outdoor exposure results in a loss of heat value varying from 2 to 10 per cent.
- (c) Dry storage has no advantage over storage in the open except with high sulphur coals, where the disintegrating effect of sulphur in the process of oxidation facilitates the escape or oxidation of the hydrocarbons.
- (d) In most cases the losses in storage appear to be practically complete at the end of five months. From the seventh to the ninth month the loss is inappreciable.

This paper contains also a historical review of the literature on weathering and on spontaneous combustion, with a summary of the opinions of various authorities.

Later experiments on storing carload lots of Illinois coals (W. F. Wheeler, *Trans. A. I. M. E.*, 1908) confirms the above conclusions, except that 4 per cent seems to be amply sufficient to cover the losses sustained by Illinois coals under regular storage-conditions, the larger losses indicated in the former series being probably due to the small size of the samples exposed.

Investigations by the U. S. Bureau of Mines in 1910 (Technical Paper No. 2) showed that New River (Va.) coal lost less than 1% in heating value in one year by weathering in the open, and Pocahontas coal less than 0.4%.

**Pressed Fuel.** (E. F. Loiseau, *Trans. A. I. M. E.*, viii. 314).—Pressed fuel has been made from anthracite dust by mixing the dust with ten per cent of its bulk of dry pitch, which is prepared by separating from tar at a temperature of 572° F. the volatile matter it contains. The mixture is kept heated by steam to 212°, at which temperature the pitch acquires its cementing properties, and is passed between two rollers, on the periphery of which are milled out a series of semi-oval cavities. The lumps of the mixture, about the size of an egg, drop out under the rollers on an endless belt, which carries them to a screen in eight minutes, which time is sufficient to cool the lumps, and they are then ready for delivery.

The enterprise of making the pressed fuel above described was not commercially successful, on account of the low price of other coal. In France, however, "*briquettes*" are regularly made of coal-dust (bituminous and semi-bituminous).

Experiments with briquets for use in locomotives have been made by the Penna. R. R. Co., with favorable results, which were reported at the convention on the Am. Ry. Mast. Mechs. Assn. (*Eng. News*, July 2, 1908). A rate of evaporation as high as 19 lb. per sq. ft. of heating surface per hour was reached. The comparative economy of raw coal and of briquets was as follows:

Evap. per sq. ft. heat. surf. per hr., lbs.	8	10	12	14	16	
Evap. from and at 212° per lb. of fuel	{ Lloydell coal... { Briquetted coal.	9.5	8.8	8.0	7.3	6.6
		10.7	10.2	9.7	9.2	8.7

The fuel consumed per draw-bar horse-power with the locomotive running at 37.8 miles per hour and a cut-off of 25% was: with raw coal, 4.48 lbs.; with round briquets, 3.65 lbs.

Experiments on different binders for briquets are discussed by J. E. Mills in Bulletin No. 343 of the U. S. Geological Survey, 1908.

Briquetting tests made at the St. Louis exhibition, 1904, with

descriptions of the machines used are reported in Bulletin No. 261 of the U. S. Geological Survey, 1905. See also paper on Coal Briquetting in the U. S., by E. W. Parker, *Trans. A. I. M. E.*, 1907.

**Spontaneous Combustion of Coal.** (Technical Paper 16, U. S. Bureau of Mines, 1912.)—Spontaneous combustion is brought about by slow oxidation in an air supply sufficient to support the oxidation, but insufficient to carry away all the heat formed. Mixed lump and fine, i. e., run-of-mine, with a large percentage of dust, and piled so as to admit to the interior a limited supply of air, make ideal conditions for spontaneous heating. High volatile matter does not of itself increase the liability to spontaneous heating.

Pocahontas coal gives a great deal of trouble with spontaneous fires in the large storage piles at Panama. The high-volatile coals of the west are usually very liable to spontaneous heating.

The influence of moisture and that of sulphur upon spontaneous heating of coal are questions not yet settled. Observation by the Bureau of Mines in many actual cases has not developed any instances where moisture could be proven to promote heating. Sulphur has been shown to have, in most cases, only a minor influence. On the other hand, a Boston company, using Nova Scotia coal of 3 to 4 per cent sulphur, has much trouble with spontaneous fires in storage.

Freshly mined coal and even fresh surfaces exposed by crushing lump coal exhibit a remarkable avidity for oxygen, but after a time become coated with oxidized material, "seasoned," as it were, so that the action of the air becomes much less vigorous. It is found that if coal which has been stored for six weeks or two months and has even become already somewhat heated, be rehandled and thoroughly cooled by the air, spontaneous heating rarely begins again.

While the following recommendations may under certain conditions be found impracticable, they are offered as being advisable precautions for safety in storing coal whenever their use does not involve an unreasonable expense.

1. Do not pile over 12 feet deep nor so that any point in the interior will be over 10 feet from an air-cooled surface.
2. If possible, store only in lump.
3. Keep dust out as much as possible; therefore reduce handling to a minimum.
4. Pile so that lump and fine are distributed as evenly as possible; not, as is often done, allowing lumps to roll down from a peak and form air passages at the bottom.
5. Rehandle and screen after two months.
6. Keep away external sources of heat even though moderate in degree.
7. Allow six weeks' "seasoning" after mining before storing.
8. Avoid alternate wetting and drying.
9. Avoid admission of air to interior of pile through interstices around foreign objects such as timbers or irregular brick work; also through porous bottoms such as coarse cinders.
10. Do not try to ventilate by pipes, as more harm is often done than good.

## COKE.

Coke is the solid material left after evaporating the volatile ingredients of coal, either by means of partial combustion in furnaces called coke ovens, or by distillation in the retorts of gas-works.

Coke made in ovens is preferred to gas coke as fuel. It is of a dark gray color, with slightly metallic luster, porous, brittle, and hard.

The proportion of coke yielded by a given weight of coal is very different for different kinds of coal, ranging from 0.9 to 0.35.

Being of a porous texture, it readily attracts and retains water from the atmosphere, and sometimes, if it is kept without proper shelter, from 0.15 to 0.20 of its gross weight consists of moisture.



## Analyses of Coke.

(From report of John R. Proctor, Kentucky Geological Survey.)

Where Made.		Fixed Carb'n.	Ash.	Sulphur.
Connellsville, Pa.	(Average of 3 samples)	88.96	9.74	0.810
Chattanooga, Tenn.	" " 4 "	80.51	16.34	1.595
Birmingham, Ala.	" " 4 "	87.29	10.54	1.195
Pocahontas, Va.	" " 3 "	92.53	5.74	0.597
New River, W. Va.	" " 8 "	92.38	7.21	0.562
Big Stone Gap, Ky.	" " 7 "	93.23	5.69	0.749

## Experiments in Coking. CONNELLSVILLE REGION.

(John Fulton, *Amer. Mfr.*, Feb. 10, 1893.)

No. of Test.	Time in Oven.	Coal Charged.	Ash made.	Fine Coke made.	Market Coke made.	Total Coke made.	Per cent of Yield.				Per Cent Lost.
							Ash.	Fine Coke.	Market Coke.	Total Coke.	
	h. m.	lb.	lb.	lb.	lb.	lb.					
1	67 00	12,420	99	385	7,518	7,903	0.80	3.10	60.53	63.63	35.57
2	68 00	11,090	90	359	6,580	6,939	0.81	3.24	59.33	62.57	36.62
3	45 00	9,120	77	272	5,418	5,690	0.84	2.98	59.41	62.39	36.77
4	45 00	9,020	74	349	5,334	5,683	0.82	3.87	59.13	63.00	36.18

These results show, in a general average, that Connellsville coal carefully coked in a modern beehive oven will yield 66.17% of marketable coke, 2.30% of small coke or breeze, and 0.82% of ash.

The total average loss in volatile matter expelled from the coal in coking amounts to 30.71%.

The beehive coke oven is 12 feet in diameter and 7 feet high at crown of dome. It is used in making 48 and 72 hour coke. [The Belgian type of beehive oven is rectangular in shape.]

In making these tests the coal was weighed as it was charged into the oven; the resultant marketable coke, small coke or breeze and ashes weighed dry as they were drawn from the oven.

**Coal Washing.**—In making coke from coals that are high in ash and sulphur, it is advisable to crush and wash the coal before coking it. A coal-washing plant at Brookwood, Ala., has a capacity of 50 tons per hour. The average percentage of ash in the coal during ten days' run varied from 14% to 21%, in the washed coal from 4.8% to 8.1%, and in the coke from 6.1% to 10.5%. During three months the average reduction of ash was 60.9%. (*Eng. and Mining Jour.*, March 25, 1893.)

An experiment on washing Missouri No. 3 slack coal is described in Bulletin No. 3 of the Engineering Experiment Station of Iowa State College, 1905. The raw coal analyzed: moisture, 14.37; ash, 28.39; sulphur, 4.30; and the washed coal, moisture, 23.90; ash, 7.59; sulphur, 2.89. Nearly 25% of the coal was lost in the operation.

**Recovery of By-products in Coke Manufacture.**—In Germany considerable progress has been made in the recovery of by-products. The Hoffman-Otto oven has been most largely used, its principal feature being that it is connected with regenerators. In 1884 40 ovens on this system were running, and in 1892 the number had increased to 1209.

A Hoffman-Otto oven in Westphalia takes a charge of 6¼ tons of dry coal and converts it into coke in 48 hours. The product of an oven annually is 1025 tons in the Ruhr district, 1170 tons in Silesia, and 960 tons in the Saar district. The yield from dry coal is 75% to 77% of coke, 2.5% to 3% of tar, and 1.1% to 1.2% of sulphate of ammonia in the Ruhr district; 65% to 70% of coke, 4% to 4.5% of tar, and 1% to 1.25% of sulphate of ammonia in the Upper Silesia region, and 68% to 72% of coke, 4% to 4.3% of tar and 1.8% to 1.9% of sulphate of

ammonia in the Saar district. A group of 60 Hoffman ovens, therefore, yields annually the following:

District.	Coke, tons.	Tar, tons.	Sulphate Ammonia, tons.
Ruhr.....	51,300	1,860	780
Upper Silesia.....	48,000	3,000	840
Saar.....	40,500	2,400	492

An oven which has been introduced lately into Germany in connection with the recovery of by-products is the Semet-Solvay, which works hotter than the Hoffman-Otto, and for this reason 73% to 77% of gas coal can be mixed with 23% to 27% of coal low in volatile matter, and yet yield a good coke. Mixtures of this kind yield a larger percentage of coke, but, on the other hand, the amount of gas is lessened, and therefore the yield of tar and ammonia is not so great.

The yield of coke by the beehive and the retort ovens respectively is given as follows in a pamphlet of the Solvay Process Co.: Connellsville coal: beehive, 66%, retort, 73%; Pocahontas: beehive, 62%, retort, 83%; Alabama: beehive, 60%, retort, 74%. (See article in *Mineral Industry*, vol. viii. 1900.)

References: F. W. Luerman, Verein Deutscher Eisenhuettenleute 1891, *Iron Age*, March 31, 1892; *Amer. Mfr.*, April 28, 1893. An excellent series of articles on the manufacture of coke, by John Fulton, of Johnstown, Pa., is published in the *Colliery Engineer*, beginning in January, 1893.

Since the above was written, great progress in the introduction of coke ovens with by-product attachments has been made in the United States, especially by the Semet-Solvay Co., Syracuse, N. Y. See paper on The Development of the Modern By-product Coke-oven, by C. G. Atwater, *Trans. A. I. M. E.*, 1902.

**Generation of Steam from Waste Heat and Gases of Coke-ovens.** (Erskine Ramsey, *Amer. Mfr.*, Feb. 16, 1894.)—The gases from a number of adjoining ovens of the beehive type are led into a long horizontal flue, and thence to a combustion-chamber under a battery of boilers. Two plants are in satisfactory operation at Tracy City, Tenn., and two at Pratt Mines, Ala.

**A Bushel of Coal.**—The weight of a bushel of coal in Indiana is 70 lbs.; in Penna., 76 lbs.; in Ala., Colo., Ga., Ill., Ohio, Tenn., and W. Va., it is 80 lbs.

**A Bushel of Coke** is almost uniformly 40 lbs., but in exceptional cases, when the coal is very light, 38, 36, and 33 lbs. are regarded as a bushel, in others from 42 to 50 lbs. are given as the weight of a bushel; in this case the coke would be quite heavy.

**Products of the Distillation of Coal.**—S. P. Sadler's Handbook of Industrial Organic Chemistry gives a diagram showing over 50 chemical products that are derived from distillation of coal. The first derivatives are coal-gas, gas-liquor, coal-tar, and coke. From the gas-liquor are derived ammonia and sulphate, chloride and carbonate of ammonia. The coal-tar is split up into oils lighter than water or crude naphtha, oils heavier than water—otherwise dead oil or tar, commonly called creosote,—and pitch. From the two former are derived a variety of chemical products.

From the coal-tar there comes an almost endless chain of known combinations. The greatest industry based upon their use is the manufacture of dyes, and the enormous extent to which this has grown can be judged from the fact that there are over 600 different coal-tar colors in use, and many more which as yet are too expensive for this purpose. Many medicinal preparations come from the series, pitch for paving purposes, and chemicals for the photographer, the rubber manufacturers and tanners, as well as for preserving timber and cloths.

The composition of the hydrocarbons in a soft coal is uncertain and quite complex; but the ultimate analysis of the average coal shows that it approaches quite nearly to the composition of CH<sub>4</sub> (marsh-gas). (W. H. Blauvelt, *Trans. A. I. M. E.*, xx. 625.)

## WOOD AS FUEL.

Wood, when newly felled, contains a proportion of moisture which varies very much in different kinds and in different specimens, ranging between 30% and 50%, and being on an average about 40%. After 8 or 12 months ordinary drying in the air the proportion of moisture is from 20 to 25%. This degree of dryness, or almost perfect dryness if required, can be produced by a few days' drying in an oven supplied with air at about 240° F. When coal or coke is used as the fuel for that oven, 1 lb. of fuel suffices to expel about 3 lb. of moisture from the wood. This is the result of experiments on a large scale by Mr. J. R. Napier. If air-dried wood were used as fuel for the oven, from 2 to 2½ lb. of wood would probably be required to produce the same effect.

The specific gravity of different kinds of wood ranges from 0.3 to 1.2. Perfectly dry wood contains about 50% of carbon, the remainder consisting almost entirely of oxygen and hydrogen in the proportions which form water. The coniferous family contains a small quantity of turpentine, which is a hydrocarbon. The proportion of ash in wood is from 1% to 5%. The total heat of combustion of all kinds of wood, when dry, is almost exactly the same, and is that due to the 50% of carbon.

The above is from Rankine: but according to the table by S. P. Sharpless in *Jour. C. I. W.*, iv. 36, the ash varies from 0.03% to 1.20% in American woods, and the fuel value, instead of being the same for all woods, ranges from 3667 (for white oak) to 5546 calories (for long-leaf pine) = 6600 to 9883 British thermal units for dry wood, the fuel value of 0.50 lb. carbon being 7300 B.T.U.

**Heating Value of Wood.**—The following table is given in several books of reference, authority and quality of coal referred to not stated.

The weight of one cord of different woods (thoroughly air-dried) in pounds is about as follows:

Hickory or hard maple..	4500	equal to	1800	coal.	(Others give 2000.)
White oak.....	3850	"	1540	"	( " 1715.)
Beech, red and black oak	3250	"	1300	"	( " 1450.)
Poplar, chestnut, & elm..	2350	"	940	"	( " 1050.)
The average pine.....	2000	"	800	"	( " 925.)

Referring to the figures in the last column, it is said:

From the above it is safe to assume that 2¼ lb. of dry wood are equal to 1 lb. average quality of soft coal and that the full value of the same weight of different woods is very nearly the same—that is, a pound of hickory is worth no more for fuel than a pound of pine, assuming both to be dry. It is important that the wood be dry, as each 10% of water or moisture in wood will detract about 12% from its value as fuel.

Taking an average wood of the analysis C 51%, H 6.5%, O 42.0%, ash 0.5%, perfectly dry, its fuel value per pound, according to Dulong's

formula,  $V = \left[ 14,600 C + 62,000 \left( H - \frac{O}{8} \right) \right]$ , is 8221 British thermal

units. If the wood, as ordinarily dried in air, contains 25% of moisture, then the heating value of a pound of such wood is three quarters of 8221 = 6165 heat-units, less the heat required to heat and evaporate the ¼ lb. of water from the atmospheric temperature, and to heat the steam made from this water to the temperature of the chimney gases, say 150 heat-units per pound to heat the water to 212°, 970 units to evaporate it at that temperature, and 100 heat-units to raise the temperature of the steam to 420° F., or 1220 in all = 305 for ¼ lb., which, subtracted from the 6165, leaves 5860 heat-units as the net fuel value of the wood per pound, or about 0.4 that of a pound of carbon.

**Composition of Wood.**

(Analysis of Woods, by M. Eugene Chevandier.)

Woods.	Carbon.	Hydrogen.	Oxygen.	Nitrogen.	Ash.
Beech.....	49.36%	6.01%	42.69%	0.91%	1.06%
Oak.....	49.64	5.92	41.16	1.29	1.97
Birch.....	50.20	6.20	41.62	1.15	0.81
Poplar.....	49.37	6.21	41.60	0.96	1.86
Willow.....	49.96	5.96	39.56	0.96	3.37
Average.....	49.70%	6.06%	41.30%	1.05%	1.80%



The following table, prepared by M. Violette, shows the proportion of water expelled from wood at gradually increasing temperatures:

Temperature.	Water Expelled from 100 Parts of Wood.			
	Oak.	Ash.	Elm.	Walnut.
257° Fahr. ....	15.26	14.78	15.32	15.55
302° Fahr. ....	17.93	16.19	17.02	17.43
347° Fahr. ....	32.13	21.22	36.94 ?	21.00
392° Fahr. ....	35.80	27.51	33.38	41.77 ?
437° Fahr. ....	44.31	33.38	40.56	36.56

The wood operated upon had been kept in store during two years. When wood which has been strongly dried by means of artificial heat is left exposed to the atmosphere, it reabsorbs about as much water as it contains in its air-dried state.

A cord of wood =  $4 \times 4 \times 8 = 128$  cu. ft. About 56% solid wood and 44% interstitial spaces. (Marcus Bull, Phila., 1829. *J. C. I. W.*, vol. i. p. 293.)

B. E. Fernow gives the percentage of solid wood in a cord as determined officially in Prussia (*J. C. I. W.*, vol. iii. p. 20):

- Timber cords, 74.07% = 80 cu. ft. per cord;
- Firewood cords (over 6" diam.), 69.44% = 75 cu. ft. per cord;
- "Billet" cords (over 3" diam.), 55.55% = 60 cu. ft. per cord;
- "Brush" woods less than 3" diam., 18.52%; Roots, 37.00%.

### CHARCOAL.

Charcoal is made by evaporating the volatile constituents of wood and peat, either by a partial combustion of a conical heap of the material to be charred, covered with a layer of earth, or by the combustion of a separate portion of fuel in a furnace, in which are placed retorts containing the material to be charred.

According to Peclet, 100 parts by weight of wood when charred in a heap yield from 17 to 22 parts by weight of charcoal, and when charred in a retort from 28 to 30 parts.

This has reference to the ordinary condition of the wood used in charcoal-making, in which 25 parts in 100 consist of moisture. Of the remaining 75 parts the carbon amounts to one half, or 37½% of the gross weight of the wood. Hence it appears that on an average nearly half of the carbon in the wood is lost during the partial combustion in a heap, and about one quarter during the distillation in a retort.

To char 100 parts by weight of wood in a retort, 12½ parts of wood must be burned in the furnace. Hence in this process the whole expenditure of wood to produce from 28 to 30 parts of charcoal is 112½ parts; so that if the weight of charcoal obtained is compared with the whole weight of wood expended, its amount is from 25% to 27% and the proportion lost is on an average  $11\frac{1}{2} \div 37\frac{1}{2} = 0.3$ , nearly.

According to Peclet, good wood charcoal contains about 0.07 of its weight of ash. The proportion of ash in peat charcoal is very variable and is estimated on an average at about 0.18. (Rankine.)

Much information concerning charcoal may be found in the Journal of the Charcoal-iron Workers' Assn., vols. i. to vi. From this source the following notes have been taken:

**Yield of Charcoal from a Cord of Wood.**—From 45 to 50 bushels to the cord in the kiln, and from 30 to 35 in the meler. Prof. Egleston in *Trans. A. I. M. E.*, viii, 395, says the yield from kilns in the Lake Champlain region is often from 50 to 60 bushels for hard wood and 50 for soft wood; the average is about 50 bushels.

The apparent yield per cord depends largely upon whether the cord is a full cord of 128 cu. ft. or not.

In a four months' test of a kiln at Goodrich, Tenn., Dr. H. M. Pierce found results as follows: Dimensions of kiln—inside diameter of base, 28 ft. 8 in.; diam. at spring of arch, 26 ft. 8 in.; height of walls, 8 ft.; rise of arch, 5 ft.; capacity, 30 cords. Highest yield of charcoal per cord of wood (measured) 59.27 bushels, lowest 50.14 bushels, average 53.65 bushels. No. of charges 12, length of each turn or period from one charging to another 11 days. (*J. C. I. W.*, vol. vi. p. 26.)

Results from Different Methods of Charcoal-making.

Coaling Methods.	Character of Wood Used.	Yield.		Bushels of Charcoal per Cord of Wood.	Weight in Lbs. per Bushel of Charcoal.
		In Volume per cent.	In Weight per cent.		
Odelstjerna's experiments	Birch dried at 230 F. ....	....	35.9	.....	.....
Mathieu's retorts, fuel excluded	{ Air dry, av. good yellow pine weighing abt. 28 lbs. per cu. ft. }	77.0	28.3	63.4	15.7
Mathieu's retorts, fuel included		65.8	24.2	54.2	15.7
Swedish ovens, av. results	{ Good dry fir and pine, mixed. }	81.0	27.7	66.7	13.3
Swedish ovens, av. results	{ Poor wood, mixed fir and pine. }	70.0	25.8	62.0	13.3
Swedish meilers exceptional	{ Fir and white-pine wood, mixed. Av. 25 lbs. per cu. ft. }	72.2	24.7	59.5	13.3
Swedish meilers, av. results	{ Av. good yellow pine weighing abt. 25 lbs. per cu. ft. }	52.5	18.3	43.9	13.3
American kilns, av. results	{ Av. good yellow pine weighing abt. 25 lbs. per cu. ft. }	54.7	22.0	45.0	17.5
American meilers, av. results		42.9	17.1	35.0	17.5

**Consumption of Charcoal in Blast-furnaces per Ton of Pig Iron:** average consumption according to census of 1880, 1.14 tons charcoal per ton of pig. The consumption at the best furnaces is much below this average. As low as 0.853 ton is recorded of the Morgan furnace; Bay furnace, 0.858; Elk Rapids, 0.884. (1892.)

**Absorption of Water and of Gases by Charcoal.**—Svedlius, in his hand-book for charcoal-burners, prepared for the Swedish Government, says: Fresh charcoal, also reheated charcoal, contains scarcely any water, but when cool it absorbs it very rapidly, so that, after twenty-four hours, it may contain 4% to 8% of water. After the lapse of a few weeks the moisture of charcoal may not increase perceptibly, and may be estimated at 10% to 15%, or an average of 12%. A thoroughly charred piece of charcoal ought, then, to contain about 84 parts carbon, 12 parts water, 3 parts ash, and 1 part hydrogen.

M. Saussure, operating with blocks of fine boxwood charcoal, freshly burnt, found that by simply placing such blocks in contact with certain gases they absorbed them in the following proportion:

	Volumes.		Volumes.
Ammonia	90.00	Carbonic oxide	9.42
Hydrochloric-acid gas	85.00	Oxygen	9.25
Sulphurous acid	65.00	Nitrogen	6.50
Sulphuretted hydrogen	55.00	Carburetted hydrogen	5.00
Nitrous oxide (laughing-gas)	40.00	Hydrogen	1.75
Carbonic acid	35.00		

It is this enormous absorptive power that renders of so much value a comparatively slight sprinkling of charcoal over dead animal matter, as a preventative of the escape of odors arising from decomposition.

In a box or case containing one cubic foot of charcoal may be stored without mechanical compression a little over nine cubic feet of oxygen, representing a mechanical pressure of one hundred and twenty-six pounds to the square inch. From the store thus preserved the oxygen can be drawn by a small hand-pump.

MISCELLANEOUS SOLID FUELS.

**Dust Fuel—Dust Explosions.**—Dust when mixed in air burns with such extreme rapidity as in some cases to cause explosions. Explosions of flour-mills have been attributed to ignition of the dust in confined passages. Experiments in England in 1876 on the effect of coal-dust in carrying flame in mines showed that in a dusty passage the flame from a

blown-out shot may travel 50 yards. Prof. F. A. Abel (*Trans. A. I. M. E.*, xiii, 260) says that coal-dust in mines much promotes and extends explosions, and that it may readily be brought into operation as a fiercely burning agent which will carry flame rapidly as far as its mixture with air extends, and will operate as an explosive agent through the medium of a very small proportion of fire-damp in the air of the mine. The explosive violence of the combustion of dust is largely due to the instantaneous heating and consequent expansion of the air. (See also paper on "Coal Dust as an Explosive Agent," by Dr. R. W. Raymond, *Trans. A. I. M. E.*, 1894.) Experiments made in Germany in 1893 show that pulverized fuel may be burned without smoke, and with high economy. The fuel, instead of being introduced into the fire-box in the ordinary manner, is first reduced to a powder by pulverizers of any construction. In the place of the ordinary boiler fire-box there is a combustion chamber in the form of a closed furnace lined with fire-brick and provided with an air-injector. The nozzle throws a constant stream of fuel into the chamber, scattering it throughout the whole space of the fire-box. When this powder is once ignited, and it is very readily done by first raising the lining to a high temperature by an open fire, the combustion continues in an intense and regular manner under the action of the current of air which carries it in. (*Mfrs. Record*, April, 1893.)

Records of tests with the Wegener powdered-coal apparatus, which is now (1900) in use in Germany, are given in *Eng. News*, Sept. 16, 1897. Illustrated descriptions of different forms of apparatus are given in the author's "Steam Boiler Economy." Coal-dust fuel is now extensively used in the United States in rotary kilns for burning Portland cement.

Powdered fuel was used in the Crompton rotary puddling-furnace at Woolwich Arsenal, England, in 1873. (*Jour. I. & S. I.*, i, 1873, p. 91.) Numerous experiments on the use of powdered fuel for steam boilers were made in the U. S. between 1895 and 1905, but they were not commercially successful.

**Peat or Turf**, as usually dried in the air, contains from 25% to 30% of water, which must be allowed for in estimating its heat of combustion. This water having been evaporated, the analysis of M. Regnault gives, in 100 parts of perfectly dry peat of the best quality: C, 58%; H, 6%; O, 31%; Ash, 5%. In some examples of peat the quantity of ash is greater, amounting to 7% and sometimes to 11%.

The specific gravity of peat in its ordinary state is about 0.4 or 0.5. It can be compressed by machinery to a much greater density. (Rankine.)

Clark (*Steam-engine*, i, 61) gives as the average composition of dried Irish peat: C, 59%; H, 6%; O, 30%; N, 1.25%; Ash, 4%.

Applying Dulong's formula to this analysis, we obtain for the heating value of perfectly dry peat 10,260 heat-units per pound, and for air-dried peat containing 25% of moisture, after making allowance for evaporating the water, 7,391 heat-units per pound.

A paper on Peat in the U. S., by M. R. Campbell, will be found in *Mineral Resources of the U. S.* (U. S. Geol. Survey) for 1905, p. 1319.

**Sawdust as Fuel.**—The heating power of sawdust is naturally the same per pound as that of the wood from which it is derived, but if allowed to get wet it is more like spent tan (which see below). The conditions necessary for burning sawdust are that plenty of room should be given it in the furnace, and sufficient air supplied on the surface of the mass, preferably by means of a fan-blast. The same applies to shavings, refuse lumber, etc. Sawdust is frequently burned in saw-mills, etc., by being blown into the furnace by a fan-blast.

**Wet Tan Bark as Fuel.**—Tan, or oak bark, after having been used in the processes of tanning, is burned as fuel. The spent tan consists of the fibrous portion of the bark. The principal cause of poor economy in the burning of tan bark besides the difficulty of securing good combustion in the furnace, is the amount of heat that is carried away in the shape of superheated steam in the chimney gases. If the bark, after partial drying by compression, were further dried in a rotary drier by waste heat from the chimney gases, there would be an important gain in economy. For calculations showing the advantages of drying, and for illustrations of tan-bark furnaces, see "Steam Boiler Economy."

D. M. Myers (*Trans. A. S. M. E.*, 1909) describes some experiments on tan as a boiler fuel. One hundred lb. of air-dried bark fed to the mill will produce 213 lb. of spent tan containing 65% moisture. Tak-



ing 9500 B.T.U. as the heating value per lb. of dry tan and 500° F. as the temperature of the chimney gases, the available heat in 1 lb. of wet tan is 2665 B.T.U. Based on this value as much as 71% efficiency has been obtained in a boiler test with a special furnace, or 1.93 lb. of water evaporated from and at 212° per lb. of wet tan. The average heating value of dry hemlock tan, as found by a bomb calorimeter in six tests by Dr. Sherman, is 9504 B.T.U. The composition of dry tan is Ash, 1.42; C, 51.80; H, 6.04; O, 40.74. By Dulong's formula the heating value would be 8152 B.T.U.

**Straw as Fuel.** (*Eng'g Mechanics*, Feb. 1893, p. 55.)—Experiments in Russia showed that winter-wheat straw, dried at 230° F., had the following composition, C, 46.1; H, 5.6; N, 0.42; O, 43.7; Ash, 4.1. Heating value in British thermal units: dry straw, 6290; with 6% water, 5770; with 10% water, 5448. With straws of other grains the heating value of dry straw ranged from 5590 for buckwheat to 6750 for flax.

Clark (S. E., vol. 1, p. 62) gives the mean composition of wheat and barley straw as C, 36; H, 5; O, 38; N, 0.50; Ash, 4.75; Water, 15.75, the two straws varying less than 1%. The heating value of straw of this composition, according to Dulong's formula, and deducting the heat lost in evaporating the water, is 5155 heat-units. Clark erroneously gives it as 8144 heat-units.

**Bagasse as Fuel in Sugar Manufacture.**—Bagasse is the name given to refuse sugar-cane, after the juice has been extracted. Prof. L. A. Becuel, in a paper read before the Louisiana Sugar Chemists' Association, in 1892, says: "With tropical cane containing 12.5% woody fibre, a juice containing 16.13% solids, and 83.87% water, bagasse of, say, 66% and 72% mill extraction has the following percentage composition:

66% bagasse: Woody Fibre, 37; Combustible Salts, 10; Water, 53.

72% bagasse: Woody Fibre, 45; Combustible Salts, 9; Water, 46.

"Assuming that the woody fibre contains 51% carbon, the sugar and other combustible matters an average of 42.1%, and that 12,906 units of heat are generated for every pound of carbon consumed, the 66% bagasse is capable of generating 297,834 heat-units per 100 lb. as against 345,200, or a difference of 47,366 units in favor of the 72% bagasse.

"Assuming the temperature of the waste gases to be 450° F., that of the surrounding atmosphere and water in the bagasse at 86° F., and the quantity of air necessary for the combustion of one pound of carbon at 24 lb., the lost heat will be as follows: In the waste gases, heating air from 86° to 450°F., and in vaporizing the moisture, etc., the 66% bagasse will require 112,546 heat-units, and 116,150 for the 72% bagasse.

"Subtracting these quantities from the above, we find that the 66% bagasse will produce 185,288 available heat-units per 100 lb., or nearly 24% less than the 72% bagasse, which gives 229,050 units. Accordingly one ton of cane of 2000 lb. at 66% mill extraction will produce 680 lb. bagasse, equal to 1,259,958 available heat-units, while the same cane at 72% extraction will produce 560 lb. bagasse, equal to 1,282,680 units.

"A similar calculation for the case of Louisiana cane containing 10% woody fibre, and 16% total solids in the juice, assuming 75% mill extraction, shows that bagasse from one ton of cane contains 1,573,956 heat-units, from which 561,465 have to be deducted, which makes such bagasse worth on an average nearly 92 lb. coal per ton of cane ground.

"It appears that with the best boiler plants, those taking up all the available heat generated, by using this heat economically the bagasse can be made to supply all the fuel required by our sugar-houses."

The figures below are from an article by Samuel Vickess (*The Engineer*, Chicago, April 1, 1903).

When canes with 12% fibre are ground, the juice extractions and liquid left in the residual bagasse are generally as follows:

With	Per Cent of Normal Juice Extracted on Weight of Cane.	Per Cent of Liquid Left in Bagasse on Weight of Bagasse.
Double crushing.....	70	60
Single crushing.....	62	68
Crusher and double crushing.....	72	57
Triple Crushing.....	76	50
Crusher and triple crushing with saturation.....	82	50

The value of bagasse as a fuel depends upon the amount of woody fibre it contains, and the amount of combustible matter (sucrose, glucose, and gums), held in the liquid it retains. 100 lb. cane with triple crushing gives 76 lb. juice, and 24 lb. bagasse, which consists of 12 lb. fibre and 12 lb. juice. The 12 lb. of juice contains 16% or 1.92 lb. sucrose, 0.5% or 0.06 lb. glucose, 2.5% other organic matter and 1% or 0.12 lb. ash, making a total of 20% or 2.4 lb. of solid matter, and 80% or 9.6 lb. of water. Reducing these figures to quantities corresponding to 1 lb. of bagasse, and multiplying by the heating values of the several substances as given by Stohlmann, viz.: fibre, 7461; sucrose, 6957; glucose, 6646; organic matter, 7461, we find the heating value of the combustible in 1 lb. of bagasse to be 4397 B.T.U. This is the gross heating value which would be obtained in a calorimeter in which the products of combustion were cooled to the temperature of the atmosphere. To find approximately the heat available for generating steam in a boiler we may assume that 10 lb. of air is used in burning each pound of bagasse, that the atmospheric temperature is 82° and the flue gas temperature 462°, and that in addition to the 0.4 lb. water per lb. bagasse half of the remaining 0.6 lb. is oxygen and hydrogen in proportions which form water, making 0.7 lb. water which escapes in the flue gas as superheated steam. The heat lost in the flue gases per pound of bagasse is  $10 \times 0.24 \times (462 - 82) + 0.7 [(212 - 82) + 970 + 0.5 (462 - 212)] = 1770$  B.T.U., which subtracted from 4397 leaves 2627 B.T.U. as the net or available heating value, which is equivalent to an evaporation of 2.7 lb. of water from and at 212°. Mr. Vickess states that in practice 1 lb. of such green bagasse evaporates 2 to 2¼ lb. from feed water at 100° into steam at 90 lb. pressure. This is equivalent to from 2.31 to 2.59 lb. from and at 212°.

E. W. Kerr, in Bulletin No. 117 of the Louisiana Agricultural Experiment Station, Baton Rouge, La., gives the results of a study of many different forms of bagasse furnaces. An equivalent evaporation of 2¼ lb. of steam from and at 212° was obtained from 1 lb. of wet bagasse of a net calorific value of 3256 B.T.U. This net value is that calculated from the analysis by Dulong's formula, minus the heat required to evaporate the moisture and to heat the vapor to the temperature of the escaping chimney gases, 594° F. The approximate composition of bagasse of 75% extraction is given as 51% free moisture, and 28% of water combined with 21% of carbon in the fibre and sugar. For the best results the bagasse should be burned at a high rate of combustion, at least 100 lb. per sq. ft. of grate per hour. Not more than 1.5 lb. of bagasse per sq. ft. of heating surface per hour should be burned under ordinary conditions, and not less than 1.5 boiler horse-power should be provided per ton of cane per 24 hours.

For illustrations of bagasse furnaces see "Steam Boiler Economy."

## LIQUID FUEL.

### Products of the Distillation of Crude Petroleum.

Crude American petroleum of sp. gr. 0.800 may be split up by fractional distillation as follows ("Robinson's Gas and Petroleum Engines"):

Temp. of Distillation Fahr.	Distillate.	Per-cent-ages.	Specific Gravity.	Flashing Point. Deg. F.
113°	Rhigolene. }	traces.	.590 to .625	.....
113 to 140°	Chymogene. }			
140 to 158°	Gasoline (petroleum spirit) ..	1.5	.636 to .657	.....
158 to 248°	Benzine, naphtha C, benzolene	10.	.680 to .700	14
248°	{ Benzine, naphtha B.....	2.5	.714 to .718	.....
to	{ Benzine, naphtha A.....	2.	.725 to .737	32
347°	{ Polishing oils.....	.....	.....	.....
338° and } upwards. }	Kerosene (lamp-oil).....	50.	.802 to .820	100 to 122
482°	Lubricating oil.....	15.	.850 to .915	230
.....	Paraffine wax.....	2.	.....	.....
.....	Residue and Loss.....	16.	.....	.....

**Lima Petroleum**, produced at Lima, Ohio, is of a dark green color, very fluid, and marks 48° Baumé at 15° C. (sp. gr., 0.792).

The distillation in fifty parts, each part representing 2% by volume, gave the following results:

Per cent.	Sp. Gr.	Per cent.	Sp. Gr.	Per cent.	Sp. Gr.	Per cent.	Sp. Gr.	Per cent.	Sp. Gr.	Per cent.	Sp. Gr.
2	0.680	18	0.720	34	0.764	50	0.802	68	0.820	88	0.815
4	.683	20	.728	36	.768	52	.806	70	.825	90	.815
6	.685	22	.730	38	.772	to		72	.830	92 to 100	Residuum
8	.690	24	.735	40	.778	58		73	.830		
10	.694	26	.740	42	.782	60	.800	.810			
12	.698	28	.742	44	.788	62	.804	.820	.818	.816	
14	.700	30	.746	46	.792	64	.808	.818			
16	.706	32	.760	48	.800	66	.812	.816			

## RETURNS.

16 per cent naphtha, 70° Baumé.      6 per cent paraffine oil.  
68 per cent burning oil.              10 per cent residuum.

The distillation started at 23° C., this being due to the large amount of naphtha present, and when 60% was reached, at a temperature of 310° C. the hydrocarbons remaining in the retort were dissociated, when gases escaped, lighter distillates were obtained, and, as usual in such cases, the temperature decreased from 310° C. down gradually to 200° C., until 75% of oil was obtained, and from this point the temperature remained constant until the end of the distillation. Therefore these hydrocarbons in *statu moriendi* absorbed much heat. (*Jour. Am. Chem. Soc.*)

There is not a good agreement between the character of the materials designated gasoline, kerosene, etc., and the temperature of distillation and densities employed in different places. The following table shows one set of values that is probably as good as any.

Name.	Boiling Point.	Specific Gravity.	Density at 59° F.
	° F.		° Baumé.
Petroleum ether.....	104-158	0.650-0.660	85-80
Gasoline.....	158-176	.660- .670	80-78
Naphtha C.....	176-212	.670- .707	78-68
Naphtha B.....	212-248	.707- .722	68-64
Naphtha A.....	248-302	.722- .737	64-60
Kerosene.....	302-572	.753- .864	56-32

Gasoline is different from a simple substance with a fixed boiling point, and therefore theoretical calculations on the heat of combustion, air necessary, and conditions for vaporizing or carbureting air are of little value. (C. E. Lucke.)

**Value of Petroleum as Fuel.**—Thos. Urquhart, of Russia (*Proc. Inst. M. E.*, Jan., 1889), gives the following table of the theoretical evaporative power of petroleum in comparison with that of coal, as determined by Messrs. Favre and Silbermann:

Fuel.	Specific Gravity at 32° F., Water = 1,000	Chem. Comp.			Heating power, British Thermal Units.	Theoret. Evap., Lb. of Water per lb. Fuel, from and at 212° F.
		C.	H.	O.		
Penna. heavy crude oil....	0.886	84.9	13.7	1.4	20,736	21.48
Caucasian light crude oil..	0.884	86.3	13.6	0.1	22,027	22.79
Caucasian heavy crude oil..	0.938	86.6	12.3	1.1	20,138	20.85
Petroleum refuse.....	0.928	87.1	11.7	1.2	19,832	20.53
Good English coal.....	1.380	80.0	5.0	8.0	14,112	14.61

In experiments on Russian railways with petroleum as fuel Mr. Urquhart obtained an actual efficiency equal to 82% of the theoretical



heating-value. The petroleum is fed to the furnace by means of a spray-injector driven by steam. An induced current of air is carried in around the injector-nozzle, and additional air is supplied at the bottom of the furnace.

Beaumont, Texas, oil analyzed as follows (*Eng. News*, Jan. 30, 1902): C, 84.60; H, 10.90; S, 1.63; O, 2.87. Sp. gr., 0.92; flash point, 142° F.; burning point, 181° F.; heating value per lb., by oxygen calorimeter, 19,060 B.T.U. A test of a horizontal tubular boiler with this oil, by J. E. Denton gave an efficiency of 78.5%. As high as 82% has been reported for California oil.

Bakersfield, Cal., oil: Sp. gr. 16° Baumé; Moisture, 1%; Sulphur, 0.5%. B.T.U. per lb., 18,500.

Redondo, Cal., oil, six lots: Moisture, 1.82 to 2.70%; Sulphur, 2.17 to 2.60%; B.T.U. per lb., 17,717 to 17,966. Kilowatt-hours generated per barrel (334 lb.) of oil in a 5000 K.W. plant, using water-tube boilers, and reciprocating engines and generators having a combined efficiency of 90.2 to 94.75% (boiler economy and steam-rate of engine not stated). 2000 K.W. load, 237.3; 3000 K.W., 256.7; 5000 K.W., 253.4; variable load, 24 hours, 243.8. (C. R. Weymouth, *Trans. A. S. M. E.*, 1908.)

The following table shows the relative values of petroleum and coal. It is based on the following assumed data: B.T.U. per lb. of oil, 19,000; sp. gr., 0.90 = 7.57 lb. per gal; 1 barrel = 42 gal. = 315 lb.

Coal, B.T.U. per lb.	1 lb. oil = lb. coal.	1 barrel oil = lb. coal.	1 ton coal = barrels oil.
10,000	1.9	598	3.34
11,000	1.727	544	3.68
12,000	1.583	499	4.01
13,000	1.462	460	4.34
14,000	1.357	427	4.68
15,000	1.267	399	5.01

From this table we see that if coal of a heating value of only 10,000 B.T.U. per lb. costs \$3.34 per ton, and coal of 14,000 B.T.U. per lb. costs \$4.68 per ton, then the price of oil will have to be as low as \$1 a barrel to compete with coal; or, if the poorer coal is \$3.34 and the better coal \$4.68 per ton, then oil will be the cheaper fuel if it is below \$1 per barrel.

### Heating Values of California Fuel Oils.

(R. W. Fenn, *Eng. News*, May 13, 1909.)

Degree Baumé.	Specific Gravity.	Weight per bbl.	B.T.U. per lb.	Thousands B.T.U. per bbl.	Degree Baumé.	Specific Gravity.	Weight per bbl.	B.T.U. per lb.	Thousands B.T.U. per bbl.
10	1.000	350	18,380	6442	28	0.887	311	19,460	6051
12	0.986	346	18,500	6394	30	0.875	307	19,580	6008
14	0.972	341	18,620	6345	32	0.865	303	19,700	5973
16	0.959	336	18,740	6302	34	0.854	299	19,820	5935
18	0.947	332	18,860	6257	36	0.844	296	19,940	5901
20	0.934	327	18,980	6212	38	0.835	293	20,050	5865
22	0.922	323	19,100	6173	40	0.825	289	20,150	5827
24	0.910	319	19,220	6133	42	0.816	286	20,250	5789
26	0.899	315	19,340	6093	44	0.806	283	20,350	5751

**Fuel Oil Burners.**—A great variety of burners are on the market, most of them based on the principle of using a small jet of steam at the boiler pressure to inject the oil into the furnace, in the shape of finely divided spray, and at the same time to draw in the air supply and mix it intimately with the oil. So far as economy of oil is concerned these burners are all of about equal value, but their successful operation depends on the construction of the furnace. This should have a large combustion chamber, entirely surrounded with fire brick, and the jet should be so directed that it will strike a fire-brick surface and rebound before touching the heating surface of the boiler. Burners

using air at high pressure, 40 lb. per sq. in., without steam, have been used with advantage. Lower pressures have been found not sufficient to atomize the oil. Mechanical atomizers have now (1915) largely replaced steam jet oil burners. See "Steam Boiler Economy."

When boilers are forced, with a combustion chamber too small to allow the oil spray to be completely burned in it before passing to the boiler surface, dense clouds of smoke result, with a deposit of lampblack or soot.

**Crude Petroleum vs. Indiana Block Coal for Steam-raising at the South Chicago Steel Works.**—(E. C. Potter, *Trans. A. I. M. E.*, xvii. 807.)—With coal, 14 tubular boilers 16 ft.  $\times$  5 ft. required 25 men to operate them; with fuel oil, 6 men were required, a saving of 19 men at \$2 per day, or \$38 per day.

For one week's work 2731 barrels of oil were used, against 848 tons of coal required for the same work, showing 3.22 barrels of oil to be equivalent to 1 ton of coal. With oil at 60 cents per barrel and coal at \$2.15 per ton, the relative cost of oil to coal is as \$1.93 to \$2.15. No evaporation tests were made.

**Petroleum as a Metallurgical Fuel.**—C. E. Felton (*Trans. A. I. M. E.*, xvii. 809) reports a series of trials with oil as fuel in steel-heating and open-hearth steel-furnaces, and in raising steam, with results as follows: 1. In a run of six weeks the consumption of oil, partly refined (the paraffine and some of the naphtha being removed), in heating 14-inch ingots in Siemens furnaces was about 6 $\frac{1}{2}$  gallons per ton of blooms. 2. In melting in a 30-ton open-hearth furnace 48 gallons of oil were used per ton of ingots. 3. In a six weeks' trial with Lima oil from 47 to 54 gallons of oil were required per ton of ingots. 4. In a six months' trial with Siemens heating-furnaces the consumption of Lima oil was 6 gallons per ton of ingots. Under the most favorable circumstances, charging hot ingots and running full capacity, 4 $\frac{1}{2}$  to 5 gallons per ton were required. 5. In raising steam in two 100-H.P. tubular boilers, the feed-water being supplied at 160° F., the average evaporation was about 12 pounds of water per pound of oil, the best 12 hours' work being 16 pounds.

**Specifications for the Purchase of Fuel Oil.**—The U. S. government specifications for the purchase of fuel oil (1914) contain the following requirements:

The oil should not have been distilled at a temperature high enough to burn it, nor at a temperature so high that flecks of carbonaceous matter begin to separate.

It should not flash below 140° F., in a closed Abel-Pensky or Pensky-Martins tester.

The specific gravity should range from 0.85 to 0.96 at 59° F.

It should flow readily, at ordinary atmospheric temperatures and under a head of 1 ft. of oil, through a 4-in. pipe 10 ft. in length.

It should not congeal nor become too sluggish to flow at 32° F.

It should have a calorific value of not less than 18,000 B.T.U. per lb. A bonus is to be paid or a penalty deducted as the fuel oil delivered is above or below the standard.

It should be rejected if it contains more than 2% water, more than 1% sulphur, or more than a trace of sand, clay or dirt.

## ALCOHOL AS FUEL.

Denatured alcohol is a grain or ethyl alcohol mixed with a denaturant in order to make it unfit for beverage or medicinal purposes. Under acts of Congress of June 7, 1906, and March 2, 1907, denatured alcohol became exempt from internal revenue taxation, when used in the industries.

The Government formulæ for completely denatured alcohol are:

1. To every 100 gal. of ethyl or grain alcohol (of not less than 180% proof) there shall be added 10 gal. of approved methyl or wood alcohol and  $\frac{1}{2}$  gal. of approved benzine. (180% proof = 90% alcohol, 10% water, by volume.)

2. To every 100 gal. of ethyl alcohol (of not less than 180% proof) there shall be added 2 gal. of approved methyl alcohol and  $\frac{1}{2}$  gal. of approved pyridin (a petroleum product) bases.

Methyl alcohol, benzine and pyridin used as denaturants must conform to specifications of the Internal Revenue Department.

The alcohol which it is proposed to manufacture under the present law is ethyl alcohol,  $C_2H_5OH$ . This material is seldom, if ever, obtained pure, it being generally diluted with water and containing other alcohols when used for engines.

SPECIFIC GRAVITY OF ETHYL ALCOHOL AT 60° F. COMPARED WITH WATER AT 60°. (Smithsonian Tables.)

Sp. Gr.	Per cent Alcohol.		Sp. Gr.	Per cent Alcohol.		Sp. Gr.	Per cent Alcohol.	
	Weight.	Vol.		Weight.	Vol.		Weight.	Vol.
0.834	85.8	90.0	0.826	88.9	92.3	0.818	91.9	94.5
.832	86.6	90.6	.824	89.6	92.9	.816	92.6	95.0
.830	87.4	91.2	.822	90.4	93.4	.814	93.3	95.5
.828	88.1	91.8	.820	91.1	94.0	.812	94.0	96.0

The heat of combustion of ethyl alcohol, 94% by volume, as determined by the calorimeter, is 11,900 B.T.U. per lb.—a little more than half that of gasoline (Lucke). Favre and Silbermann obtained 12,913 B.T.U. for absolute alcohol. Dulong's formula for  $C_2H_5OH$  gives 13,010 B.T.U.

The products of complete combustion of alcohol are  $H_2O$  and  $CO_2$ . Under certain conditions, with an insufficient supply of air, acetic acid is formed, which causes rusting of the parts of an alcohol engine. This may be prevented by addition to the alcohol of benzol or acetylene.

With any good small stationary engine as small a consumption as 0.70 lb. of gasoline, or 1.16 lb. of alcohol per brake H.P. hour may reasonably be expected under favorable conditions (Lucke).

References.—H. Diederichs, *Intl. Marine Eng'g*, July, 1906; *Machy.*, Aug., 1906. C. E. Lucke and S. M. Woodward, *Farmer's Bulletin*, No. 277, U. S. Dept. of Agriculture, 1907. *Eng. Rec.*, Nov. 2, 1907. T. L. White, *Eng. Mag.*, Sept., 1908.

VAPOR PRESSURE OF SATURATION FOR VARIOUS LIQUIDS, IN MILLIMETERS OF MERCURY.

(To convert into pounds per sq. in., multiply by 0.01934; to convert into inches of mercury, multiply by 0.03937.)

Temperature.	Pure Ethyl Alcohol.	Pure Methyl Alcohol.	Water.	Gasoline.	Temperature.		Pure Ethyl Alcohol.	Pure Methyl Alcohol.	Water.	Gasoline.	
					° C.	° F.					
0	32	12	30	5	99	35	95	103	204	42	301
5	41	17	40	7	115	40	104	134	259	55	360
10	50	24	54	9	133	45	113	172	327	71	422
15	59	32	71	13	154	50	122	220	409	92	493
20	68	44	94	17	179	55	131	279	508	117	561
25	77	59	123	24	210	60	140	350	624	149	648
30	86	78	159	32	251	65	149	437	761	187	739

VAPOR TENSION OF ALCOHOL AND WATER, AND DEGREE OF SATURATION OF AIR WITH THESE VAPORS.

Temp., Degr. F.	Vapor Tension, Inches Mercury.		1 Pound of Air Contains in Saturated Condition, in Pounds.			
	Alcohol Vapor.	Water Vapor.	At 28.95 Inches.		At 26.05 Inches.	
			Alcohol Vapor.	Water Vapor.	Alcohol Vapor.	Water Vapor.
50	0.950	0.359	0.055	0.008	0.061	0.009
59	1.283	0.500	0.075	0.011	0.084	0.013
68	1.723	0.687	0.104	0.016	0.117	0.018
77	2.325	0.925	0.144	0.022	0.162	0.025
86	3.090	1.240	0.200	0.031	0.227	0.036
104	5.270	2.162	0.390	0.063	0.450	0.072
122	8.660	3.620	0.827	0.135	1.002	0.164



FUEL GAS.

The following notes are extracted from a paper by W. J. Taylor on "The Energy of Fuel" (*Trans. A. I. M. E.*, xviii. 205):

**Carbon Gas.**—In the old Siemens producer, practically all the heat of primary combustion—that is, the burning of solid carbon to carbon monoxide, or about 30% of the total carbon energy—was lost, as little or no steam was used in the producer, and nearly all the sensible heat of the gas was dissipated in its passage from the producer to the furnace, which was usually placed at a considerable distance.

Modern practice has improved on this plan, by introducing steam with the air blown into the producer, and by utilizing the sensible heat of the gas in the combustion-furnace. It ought to be possible to oxidize one out of every four lbs. of carbon with oxygen derived from water-vapor. The thermic reactions in this operation are as follows:

	Heat-units.
4 lbs. C burned to CO (3 lbs. gasified with air and 1 lb. with water) develop.....	17,600
1.5 lbs. of water (which furnish 1.33 lbs. of oxygen to combine with 1 lb. of carbon) absorb by dissociation.....	10,333
The gas, consisting of 9.333 lbs. CO, 0.167 lb. H, and 13.39 lbs. N, heated 600°, absorbs.....	3,748
Leaving for radiation and loss.....	3,519
	17,600

The steam which is blown into a producer with the air is almost all condensed into finely-divided water before entering the fuel, and consequently is considered as water in these calculations.

The 1.5 lbs. of water liberates 0.167 lb. of hydrogen, which is delivered to the gas, and yields in combustion the same heat that it absorbs in the producer by dissociation. According to this calculation, therefore, 60% of the heat of primary combustion is theoretically recovered by the dissociation of steam, and, even if all the sensible heat of the gas be counted, with radiation and other minor items, as loss, yet the gas must carry  $4 \times 14,500 - (3748 + 3519) = 50,733$  heat-units, or 87% of the calorific energy of the carbon. This estimate shows a loss in conversion of 13%, without crediting the gas with its sensible heat, or charging it with the heat required for generating the necessary steam, or taking into account the loss due to oxidizing some of the carbon to CO<sub>2</sub>. In good producer-practice the proportion of CO<sub>2</sub> in the gas represents from 4% to 7% of the C burned to CO<sub>2</sub>, but the extra heat of this combustion should be largely recovered in the dissociation of more water-vapor, and therefore does not represent as much loss as it would indicate. As a conveyer of energy, this gas has the advantage of carrying 4.46 lbs. less nitrogen than would be present if the fourth pound of coal had been gasified with air; and in practical working the use of steam reduces the amount of clinking in the producer.

**Anthracite Gas.**—In anthracite coal there is a volatile combustible varying in quantity from 1.5% to over 7%. The amount of energy derived from the coal is shown in the following theoretical gasification made with coal of assumed composition: Carbon, 85%; vol. HC, 5%; ash, 10%; 80 lbs. carbon assumed to be burned to CO; 5 lbs. carbon burned to CO<sub>2</sub>; three fourths of the necessary oxygen derived from air, and one fourth from water.

Process.	Products.		
	Pounds.	Cubic Feet.	Anal. by Vol.
80 lbs. C burned to CO .....	186.66	2529.24	33.4
5 lbs. C burned to CO <sub>2</sub> .....	18.33	157.64	2.0
5 lbs. vol. HC (distilled).....	5.00	116.60	1.6
120 lbs. oxygen are required, of which 30 lbs. from H <sub>2</sub> O liberate H .....	3.75	712.50	9.4
90 lbs. from air are associated with N.....	301.05	4064.17	53.6
	514.79	7580.15	100.0

Energy in the above gas obtained from 100 lbs. anthracite:

186.66 lbs CO .....	807,304	heat-units.
5.00 " CH <sub>4</sub> .....	117,500	"
3.75 " H .....	232,500	"
	<hr/>	
	1,157,304	"
Total energy in gas per lb .....	2,248	"
Total energy in 100 lbs. of coal....	1,349,500	"
Efficiency of the conversion.....	86%	

The sum of CO and H exceeds the results obtained in practice. The sensible heat of the gas will probably account for this discrepancy and, therefore, it is safe to assume the possibility of delivering at least 82% of the energy of the anthracite.

**Bituminous Gas.** — A theoretical gasification of 100 lbs of coal, containing 55% of carbon and 32% of volatile combustible (which is above the average of Pittsburgh coal), is made in the following table. It is assumed that 50 lbs. of C are burned to CO and 5 lbs. to CO<sub>2</sub>; one fourth of the O is derived from steam and three fourths from air; the heat value of the volatile combustible is taken at 20,000 heat-units to the pound. In computing volumetric proportions all the volatile hydrocarbons, fixed as well as condensing, are classed as marsh-gas, since it is only by some such tentative assumption that even an approximate idea of the volumetric composition can be formed. The energy, however, is calculated from weight:

Process.	Products.		
	Pounds.	Cubic Feet.	Anal. by Vol.
50 lbs. C burned to CO .....	116.66	1580.7	27.8
5 lbs. C burned to CO <sub>2</sub> .....	18.33	157.6	2.7
32 lbs. vol. HC (distilled) .....	32.00	746.2	13.2
80 lbs. O are required, of which 20 lbs., derived from H <sub>2</sub> O, liberate H .....	2.5	475.0	8.3
60 lbs. O, derived from air, are associated with N .....	200.70	2709.4	47.8
	<hr/>	<hr/>	<hr/>
	370.19	5668.9	99.8

Energy in 116.66 lbs. CO .....	504,554	heat-units.
" " 32.00 lbs. vol. HC .....	640,000	"
" " 2.50 lbs. H .....	155,000	"
	<hr/>	
	1,299,554	"
Energy in coal .....	1,437,500	"
Per cent of energy delivered in gas .....	90.0	
Heat-units in 1 lb. of gas .....	3,484	

**Water-gas.** — Water-gas is made in an intermittent process, by blowing up the fuel-bed of the producer to a high state of incandescence (and in some cases utilizing the resulting gas, which is a lean producer-gas), then shutting off the air and forcing steam through the fuel, which dissociates the water into its elements of oxygen and hydrogen, the former combining with the carbon of the coal, and the latter being liberated.

This gas can never play a very important part in the industrial field, owing to the large loss of energy entailed in its production, yet there are places and special purposes where it is desirable, even at a great excess in cost per unit of heat over producer-gas; for instance, in small high-temperature furnaces, where much regeneration is impracticable, or where the "blow-up" gas can be used for other purposes instead of being wasted.

The reactions and energy required in the production of 1000 feet of water-gas, composed, theoretically, of equal volumes of CO and H, are as follows:

500 cubic feet of H weigh .....	2.635	lbs.
500 cubic feet of CO weigh .....	36.89	"

Total weight of 1000 cubic feet .....

39.525 lbs.  
Now, as CO is composed of 12 parts C to 16 of O, the weight of C in 36.89 lbs. is 15.81 lbs. and of O 21.08 lbs. When this oxygen is derived

from water it liberates, as above, 2.635 lbs. of hydrogen. The heat developed and absorbed in these reactions (roughly, as we will not take into account the energy required to elevate the coal from the temperature of the atmosphere to, say, 1800°) is as follows:

	Heat-units.
2.635 lbs. H. absorb in dissociation from water	$2.635 \times 62,000 = 163,370$
15.81 lbs. C burned to CO develops	$15.81 \times 4400 = 69,564$
Excess of heat-absorption over heat-development	= 93,806

If this excess could be made up from C burnt to CO<sub>2</sub> without loss by radiation, we would only have to burn an additional 4.83 lbs. C to supply this heat, and we could then make 1000 feet of water-gas from 20.64 lbs. of carbon (equal 24 lbs. of 85% coal). This would be the perfection of gas-making, as the gas would contain really the same energy as the coal; but instead, we require in practice more than double this amount of coal and do not deliver more than 50% of the energy of the fuel in the gas, because the supporting heat is obtained in an indirect way and with imperfect combustion. Besides this, it is not often that the sum of CO and H exceed 90%, the balance being CO<sub>2</sub> and N. But water-gas should be made with much less loss of energy by burning the "blow-up" (producer) gas in brick regenerators, the stored-up heat of which can be returned to the producer by the air used in blowing-up.

The following table shows what may be considered average volumetric analyses, and the weight and energy of 1000 cubic feet, of the four types of gases used for heating and illuminating purposes:

	Natural Gas.	Coal-gas.	Water-gas.	Producer-gas.	
				Anthra.	Bitu.
CO.....	0.50	6.0	45.0	27.0	27.0
H.....	2.18	46.0	45.0	12.0	12.0
CH <sub>4</sub> .....	92.6	40.0	2.0	1.2	2.5
C <sub>2</sub> H <sub>4</sub> .....	0.31	4.0	.....	.....	0.4
CO <sub>2</sub> .....	0.26	0.5	4.0	2.5	2.5
N.....	3.61	1.5	2.0	57.0	56.2
O.....	0.34	0.5	0.5	0.3	0.3
Vapor.....	.....	1.5	1.5	.....	.....
Pounds in 1000 cubic feet.....	45.6	32.0	45.6	65.6	65.9
Heat-units in 1000 cubic feet....	1,100,000	735,000	322,000	137,455	156,917

**Natural Gas in Ohio and Indiana.**

(Eng. and M. J., April 21, 1894.)

	Fos-toria, O.	Find-lay, O.	St. Mary's, O.	Muncie, Ind.	Ander-son, Ind.	Koko-mo, Ind.	Mar-ri-son, Ind.
Hydrogen.....	1.89	1.64	1.94	2.35	1.86	1.42	1.20
Marsh-gas.....	92.84	93.35	93.85	92.67	93.07	94.16	93.57
Olefiant gas.....	.20	.35	.20	.25	.47	.30	.15
Carbon monoxide.	.55	.41	.44	.45	.73	.55	.60
Carbon dioxide....	.20	.25	.23	.25	.26	.29	.30
Oxygen.....	.35	.39	.35	.35	.42	.30	.55
Nitrogen.....	3.82	3.41	2.98	3.53	3.02	2.80	3.42
Hydrogen sulphide	.15	.20	.21	.15	.15	.18	.20

**Natural Gas as a Fuel for Boilers.** — J. M. Whitham (*Trans. A. S. M. E.*, 1905) reports the results of several tests of water-tube boilers with natural gas. The following is a condensed statement of the results:

Kind of Boiler.	Cook Vertical.		Heine.			Cahall Vert.	
Rated H.P. of boilers.....	1500	1500	200	200	200	300	300
H.P. developed.....	1642	1507	155	218	258	340	260
Temperature at chimney	521	494	386	450	465	406	374
Gas pressure at burners, oz.	6.9	6.4	...	...	...	4.8	7 to 30
Cu. ft. of gas per boiler..							
H.P.-hour.....	44.9*	41.0*	46.0†	40.7†	38.3†	42.3	34
Boiler efficiency. %.....	72.7	...	65.8	...	74.9	...	...

\*Reduced to 4 oz. press. and 62° F. †Reduced to atmos. press. and 32° F.



Six tests by Daniel Ashworth on 2-flue horizontal boilers gave cu. ft. of gas per boiler H.P. hour, 58.0; 59.7; 67.0; 63.0; 74.0; 47.0.

On the first Cook boiler test, the chimney gas, analyzed by the Orsat apparatus, showed 7.8 CO<sub>2</sub>; 8.05 O; 0.0 CO; 84.15 N. This shows an excessive air supply.

*White versus Blue Flame.* — Tests were made with the air supply throttled at the burners, so as to produce a white flame, and also unthrottled, producing a blue flame with the following results:

Pressure of gas at burners, oz.....	4		6		8	
	White	Blue	White	Blue	White	Blue
Kind of flame.....	247	213	297	271	255	227
Boiler H.P. made per 250-H.P. boiler						
Cu. ft. of gas (at 4 oz. and 60° F.) per						
H.P. hour.....	41	41	41.6	37.9	40	43.1
Chimney temperature.....	436	503	478	511	502	508

Average of 6 tests — White, 266 H.P., 43.6 cu. ft.; Blue, 237 H.P., 43.8 cu. ft., showing that the economy is the same with each flame, but the capacity is greatest with the white flame. Mr. Whitham's principal conclusions from these tests are as follows:

- (1) There is but little advantage possessed by one burner over another.
- (2) As good economy is made with a blue as with a white or straw flame, and no better.
- (3) Greater capacity may be made with a straw-white than with a blue flame.
- (4) An efficiency as high as from 72 to 75 per cent in the use of gas is seldom obtained under the most expert conditions.
- (5) Fuel costs are the same under the best conditions with natural gas at 10 cents per 1000 cu. ft. and semi-bituminous coal at \$2.87 per ton of 2240 lbs.
- (6) Considering the saving of labor with natural gas, as compared with hand-firing of coal, in a plant of 1500 H.P., and coal at \$2 per ton of 2240 lbs., gas should sell for about 10 cents per 1000 cu. ft.

#### ANALYSES OF NATURAL GAS.

Illuminants.....	0.45	0.15	0.50	1.6
Carbonic oxide.....	0.00	0.00	0.15	1.8
Hydrogen.....	0.20	0.30	0.25	0.3
Marsh gas.....	81.05	83.20	83.40	81.9
Ethane.....	17.60	15.55	15.40	13.2
Carbonic acid.....	0.00	0.20	0.00	0.0
Oxygen.....	0.15	0.10	0.00	0.4
Nitrogen.....	0.55	0.50	0.30	0.8
B.T.U. per cu. ft. at 60° F. and				
14.7 lbs. barometer.....	1030	1020	1026	1098

The first three analyses are of the gas from nine wells in Lewis Co., W. Va.; the last is from a mixture from fields in three states supplying Pittsburg, Pa., used in the tests of the Cook boiler.

#### Producer-gas from One Ton of Coal.

(W. H. Blauvelt, *Trans. A. I. M. E.*, xviii, 614.)

Analysis by Vol.	Per Cent.	Cubic Feet.	Lbs.	Equal to —
CO.....	25.3	33,213.84	2451.20	1050.51 lbs. C + 1400.7 lbs. O.
H.....	9.2	12,077.76	63.56	63.56 " H.
CH <sub>4</sub> .....	3.1	4,069.68	174.66	174.66 " CH <sub>4</sub> .
C <sub>2</sub> H <sub>4</sub> .....	0.8	1,050.24	77.78	77.78 " C <sub>2</sub> H <sub>4</sub> .
CO <sub>2</sub> .....	3.4	4,463.52	519.02	141.54 " C + 377.44 lbs. O.
N (by difference)	58.2	76,404.96	5659.63	7350.17 " Air.
	100.0	131,280.00	8945.85	

Calculated upon this basis, the 131,280 ft. of gas from the ton of coal contained 20,311,162 B.T.U., or 155 B.T.U. per cubic ft., or 2270 B. T.U. per lb.

The composition of the coal from which this gas was made was as follows: Water, 1.26%; volatile matter, 36.22%; fixed carbon, 57.98%; sulphur, 0.70%; ash, 3.78%. One ton contains 1159.6 lbs. carbon and 724.4 lbs. volatile combustible, the energy of which is 31,302,200 B.T.U. Hence, in the processes of gasification and purification there was a loss of 35.2% of the energy of the coal.

The composition of the hydrocarbons in a soft coal is uncertain and quite complex; but the ultimate analysis of the average coal shows that it approaches quite nearly to the composition of CH<sub>4</sub> (marsh-gas).

Mr. Blauvelt emphasizes the following points as highly important in soft-coal producer-practice:

First. That a large percentage of the energy of the coal is lost when the gas is made in the ordinary low producer and cooled to the temperature of the air before being used. To prevent these sources of loss, the producer should be placed so as to lose as little as possible of the sensible heat of the gas, and prevent condensation of the hydrocarbon vapors. A high fuel-bed should be carried, keeping the producer cool on top, thereby preventing the breaking-down of the hydrocarbons and the deposit of soot, as well as keeping the carbonic acid low.

Second. That a producer should be blown with as much steam mixed with the air as will maintain incandescence. This reduces the percentage of nitrogen and increases the hydrogen, thereby greatly enriching the gas. The temperature of the producer is kept down, diminishing the loss of heat by radiation through the walls, and in a large measure preventing clinkers.

**The Combustion of Producer-gas.** (H. H. Campbell, *Trans. A. I. M. E.*, xix, 128.) — The combustion of the components of ordinary producer-gas may be represented by the following formulæ:

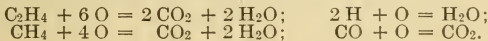

AVERAGE COMPOSITION BY VOLUME OF PRODUCER-GAS: A, MADE WITH OPEN GRATES, NO STEAM IN BLAST; B, OPEN GRATES, STEAM-JET IN BLAST. 10 SAMPLES OF EACH.

	CO <sub>2</sub> .	O.	C <sub>2</sub> H <sub>4</sub> .	CO.	H.	CH <sub>4</sub> .	N.
A min.....	3.6	0.4	0.2	20.0	5.3	3.0	58.7
A max.....	5.6	0.4	0.4	24.8	8.5	5.2	61.4
A average.....	4.84	0.4	0.34	22.1	6.8	3.74	61.78
B min.....	4.6	0.4	0.2	20.8	6.9	2.2	57.2
B max.....	6.0	0.8	0.4	24.0	9.8	3.4	62.0
B average.....	5.3	0.54	0.36	22.74	8.37	2.56	60.13

The coal used contained carbon 82%, hydrogen 4.7%.

The following are analyses of products of combustion:

	CO <sub>2</sub> .	O.	CO.	CH <sub>4</sub> .	H.	N.
Minimum.....	15.2	0.2	trace.	trace.	trace.	80.1
Maximum.....	17.2	1.6	2.0	0.6	2.0	83.6
Average.....	16.3	0.8	0.4	0.1	0.2	82.2

**Proportions of Gas Producers and Scrubbers.** (F. C. Tryon, *Power*, Dec. 1, 1908.) — Small inside diameter means excessive draft through the fire. If a fire is forced, as will be necessary with too small an inside diameter, the results will be clinkers and blow-holes or chimneys through the fire bed, with excess CO<sub>2</sub> and weak gas; clinkers fused to the lining, and burning out of grates. If sufficient steam is used to keep down the excessive heat, the result is likely to be too much hydrogen in the gas, with the attendant engine troubles.

The lining should never be less than 9 in. thick even in the smaller sizes, and a 100-H.P., or larger, producer should have at least 12 in. of generator lining. The lining next to the fire bed should be of the best quality of refractory material. A good lining consists of a course of soft common bricks put in edgewise next to the steel shell of the generator, laid in Portland cement; then a good firebrick 6 in. thick laid inside to fit the circle, the bricks being dipped as laid in a fine grouting of ground firebrick.

If we take 11¼ lbs. of coal per H.P.-hour as a fair average and 10 lbs. of

coal per hour per square foot of internal fuel-bed cross-section, with 9 in. of refractory lining up to 100 H.P. and at least 12 in. of lining on larger sizes, the generator will give good gas without forcing and without excessive heat in the zone of complete combustion. A 200-H.P. producer on this basis consumes 250 lbs. of coal at full load, and at 10 lbs. per sq. ft. internal area 25 sq. ft. will be necessary. With a 12-in. lining the outside diameter will be 92 in.

Practice has shown that the depth of the fuel bed should never be less than the inside diameter up to 6 ft.; above this size the depth can be adjusted as experience indicates the best working results. Assuming for a 200-H.P. producer 18 in. for the ashpit below the grate, 12 in. for the thickness of the grate and the ashes to protect it, 68 in. depth of fuel bed, 24 in. above the fuel to the gas outlet, the height will be 10 ft. 4 in. to the top of the generator; above this the coal-feeding hopper, say 32 in. high, is mounted; this makes the height over all 13 ft.

The wet scrubber of a gas producer should be of ample size to cool the gas to atmospheric temperature and wash out most of the impurities. A good rule is to make its diameter three-fourths that of the inside diameter of the generator and the height one and one-half times the height of the generator shell. For a 100-H.P. producer, 4 ft. inside diam., the wet scrubber should be 3 ft. inside diam., and if the generator shell is 8 ft. 6 in. high, the scrubber should be 12 ft. 9 in. high. When filled with the proper amount of baffling and scrubbing material (coke is commonly used), the scrubber will have space for about 30 cu. ft. of gas. A 100-H.P. gas engine using 12,000 B.T.U. per H.P.-hour will use 160 cu. ft. of 125-B.T.U. gas per minute. The wet scrubber will therefore be emptied  $5\frac{1}{3}$  times every minute, and would require about  $8\frac{1}{3}$  gallons of water per minute; if the diameter of the scrubber were reduced one-third the volume of water necessary to cool and scrub the gas would have to be doubled. Gas must be cooled below 90° F. to enable it to give up the impurities it carries in suspension, and even lower than this to condense its moisture.

A separate dry scrubber with two compartments should always be provided and the piping between the two scrubbers so arranged that the gas can be turned into either part of the dry scrubber at will. The dry scrubber should be equal in area to the inside of the generator, and the depth of each part should be sufficient to accommodate at least 2 cu. ft. of scrubbing material and give 1 cu. ft. of space next to the outlet. Oil-soaked excelsior is a good scrubbing material and should be packed as closely as possible.

Taking as the standard the dimensions above stated for the different parts of a producer-gas plant, a list of dimensions for different horse-power capacities would be about as in the following table.

DIMENSIONS OF GAS PRODUCERS AND SCRUBBERS.

H.P.	Producers.			Wet Scrubbers.		Dry Scrubbers.	
	Inside Diam.	Outside Diam.	Height.	Diam.	Height.	Diam.	Height.
25	24	42	6 6	18	9 9	Single...	24 3 0
35	28	46	6 10	21	10 3	...do....	28 3 0
50	34	52	7 4	26	11 0	Double.	34 6 0
60	37	55	7 7	28	11 5	...do....	37 6 0
75	42	60	8 0	32	12 0	...do....	42 6 0
100	48	72	8 6	36	12 9	...do....	48 7 0
125	54	78	9 6	41	14 3	...do....	52 7 0
150	58	82	9 10	44	14 9	...do....	58 7 6
175	63	87	10 3	48	15 5	...do....	63 7 6
200	68	92	10 8	51	16 0	...do....	68 7 6

The inside diameter of the producers corresponds to the formula  
 $H.P. = 6.25d^2$ .



**Gas Producer Practice.** — The following notes on gas producers are condensed from the catalogue of the Morgan Construction Co.

The Morgan Continuous Gas Producer is made in the following sizes:

Diam. inside of lining, ft.....	6	8	10	12
Area of gas-making surface, sq. ft.....	28	50	78.5	113
24-hour capacity with good coal, tons.....	4	7	10	15
Diam. of outlet, in. ....	20	27	33	40

The best coal to buy for a producer in any locality is that which by analysis or calorimeter test shows the most heat units for a dollar. It rarely pays to buy gas coal unless it can be had at a moderate cost over the ordinary steam bituminous grade. For very high temperature melting operations a fairly high percentage of volatile matter is necessary to give a luminous flame and intensify the radiation from the roof of the furnace. Freely burning gas coals are the most easily gasified, and the capacity of the producer to handle these coals is twice as great as when a slaty, dirty coal, high in ash and sulphur, is used. It is usually best to use "run-off-mine" coal, crushed at the mine to pass a 4-in. ring. It never pays to use slack coal, for it cuts down the capacity by choking the blast, which has to be run at high pressure to get through the fire, overheating the gas and lowering the efficiency of the producer.

There is always a certain amount of CO<sub>2</sub> formed, even in the best practice; in fact, it is inevitable, and if kept within proper limits does not constitute a net loss of efficiency, especially with very short gas flues, because the energy of the fuel so burned is represented in the sensible heat or temperature of the gas, and results in delivering a hot gas to the furnace. The best result is at about 4% CO<sub>2</sub>, a gas temperature between 1100° and 1200° F., and flues less than 100 ft. long.

The amount of steam required to blow a gas producer is from 33% to 40% of the weight of the fuel gasified. If 30 lbs. of steam is called a standard horse-power, we have therefore to provide about 1 H.P. of steam for every 80 lbs. of coal gasified per hour or for every ton of coal gasified in 24 hours.

In the original Siemens air-blown producer about 70% of the whole gas was inert and 30% combustible. Then with the advent of steam-blown producers the dilution was reduced to about 60%, with 40% combustible. Now, under the system of automatic feed, uniform conditions, perfect distribution and adjustment of the steam blast here presented, we are able to reduce the nitrogen to 50% and sometimes less.

In the best practice the volume of gas from the producer is now reduced to about 60 cu. ft. per pound of coal, of which 30 cu. ft. are nitrogen. These volumes are measured at 60° F.

The temperature of the gas leaving the producer under best modern conditions is about 1200° F. It can be run cooler than this, but not much, except at a sacrifice of both quantity and quality. At this temperature, the sensible heat carried by the gas is  $1200 \times 0.35$  (average specific heat) = 420 B.T.U. per pound. As one pound of good gas is about 16 cu. ft. and carries about  $16 \times 180 = 2880$  heat units at normal temperature, we see that the sensible heat carried away represents about one-seventh, or over 14% of the combustive energy, which is much too large a percentage to lose whenever it can be utilized by using the gas at the temperature at which it is made.

**Capacity of Producers.** — The capacity of a gas producer is a varying quantity, dependent upon the construction of the producer and upon the quality of the coal supplied to it. The point is, not to push the producer so hard as to burn up the gas within it; also to avoid blowing dust through into the flues. These two limitations in a well-constructed automatically fed gas producer occur at about the same rate of gasification, namely, at about 10 lbs. per sq. ft. of surface per hour with bituminous coal carrying 10% of ash and 1½% of sulphur. With gas coal, having high volatile percentage and low ash, this rate can be safely increased to 12 lbs. and in some cases to 15 lbs. per sq. ft. At 10 lbs. per sq. ft., the capacity of a gas producer 8 ft. internal diameter is 500 lbs. per hour, which with gas coals may be increased to a maximum of about 700 lbs. It frequently happens that the cheapest coal available is of such quality that neither of these figures can be reached, and the gasification per sq. ft. has to be cut down to 6 or 7 lbs. per hour to get the best results.

**Flues.** — It is necessary to provide large flue capacity and to carry the full area right up to the furnace ports, which latter may be slightly reduced to give the gas a forward impetus. Generally speaking, the net area of a flue should not be less than  $\frac{1}{16}$  of the area of the gas-making surface in the producers supplying it. Or it may be stated thus: — The carrying capacity of a hot gas flue is equivalent to 200 lbs. of coal per hour per sq. ft. of section.

**Loss of Energy in a Gas Producer.** — The total loss from all sources in the gasification of fuel in a gas producer under fairly good conditions, when the gas is used cold or when its sensible heat is not utilized, ranges between 20% and 25%, which under very bad conditions may be increased to 50%. The loss under favorable conditions, using the gas hot, is reduced to as low as 10%, which also includes the heat of the steam used in blowing.

**Test of a Morgan Producer.** — The following is the record of a test made in Chicago by Robert W. Hunt & Co. The coal used was Illinois "New Kentucky" run-of-mine of the following analysis: —

Fixed carbon, 50.87; volatile matter, 37.32; moisture, 5.08; ash (1.12 sulphur), 6.73. The average of all the gas analyses by volume is as follows: CO, 24.5; H, 17.8; CH<sub>4</sub> and C<sub>2</sub>H<sub>4</sub>, 6.8; total combustibles, 49.1%; CO<sub>2</sub>, 3.7; O, 0.4; N, 46.8; total non-combustibles, 50.9%.

Average depth of fuel bed, 3 ft. 4 in. Average pressure of steam on blower, 4.7 lbs. per sq. in. Analysis of ash: combustible, 4.66%; non-combustible, 95.34%. Percentage of fuel lost in the ash,  $4.66 \times 6.73 \div 100 = 0.3\%$ .

**High Temperature Required for Production of CO.** — In an ordinary coal fire, with an excess of air CO<sub>2</sub> is produced, with a high temperature. When the thickness of the coal bed is increased so as to choke the air supply CO is produced, with a decreased temperature. It appears, however, that if the temperature is greatly lowered, CO<sub>2</sub> instead of CO will be produced notwithstanding the diminished air supply. Herr Ernst (*Eng'g*, April 4, 1893) holds that the oxidation of C begins at 752° F., and that CO<sub>2</sub> is then formed as the main product, with only a small amount of CO, whether the air be admitted in large or in small quantities. When the rate of combustion is increased and the temperature rises to 1292° F. the chief product is CO<sub>2</sub> even when the exhaust gases contain 20% by volume of CO<sub>2</sub>, which is practically the maximum limit, proving that all the oxygen has been consumed. Above 1292° F. the proportion of CO rapidly increases until 1823° F. is reached, when CO is exclusively produced.

Experiments reported by J. K. Clement and H. A. Grine in Bulletin No. 393 of the U. S. Geological Survey, 1909, show that with the rate of flow of gas and the depth of fuel bed which obtain in a gas producer a temperature of 1100° C. (2012° F.) or more is required for the formation of 90% CO gas from CO<sub>2</sub> and charcoal, and 1300° (2372° F.) for the same percentage from CO<sub>2</sub> and coke, and from CO<sub>2</sub> and anthracite coal. With a temperature 100° C. (180° F.) lower than these the resultant gas will contain about 50% CO. It follows that the temperature of the fuel bed of the gas producer must be at least 1300° C. in order to yield the highest possible percentage of CO.

**The Mond Gas Producer** is described by H. A. Humphrey in *Proc. Inst. C. E.*, vol. cxxix, 1897. The producer, which is combined with a by-product recovery plant, uses cheap bituminous fuel and recovers from it 90 lbs. of sulphate of ammonia per ton, and yields a gas suitable for gas engines and all classes of furnace work. The producer is worked at a much lower temperature than usual, due to the large quantity of superheated steam introduced with the air, amounting to more than twice the weight of the fuel. The gas containing the ammonia is passed through an absorbing apparatus, and treated so that 70% of the original nitrogen of the fuel is recovered. The result of a test showed that for every ton of fuel about 2.5 tons of steam and 3 tons of air are blown through the grate, the mixture being at a temperature of about 480° F. The greater part of this steam passes through the producer undecomposed, its heat being used in a regenerator to furnish fresh steam for the producer. More than 0.5 ton of steam is decomposed in passing through the hot fuel, and nearly 4.5 tons of gas are produced from a ton of coal, equal to about 160,000 cu. ft. at ordinary atmospheric temperature. The gas has a calorific power of 81% of that of the original fuel. Mr. Humphrey gives the following table showing the relative value of different gases.

Volume per cent.	Mond Producer Gas from Bituminous Fuel.	Siemens Producer Gas.	Dowson Producer Gas from Anthracite.	Lenceauez Producer Gas from Anthracite.	Solvay Coke-Oven Gas.	Coal-Gas (Illuminating).	Pittsburgh Natural Gas.
Hydrogen (H).....	24.8	8.6	18.73	20.0	56.9	48.0	22.0
Marsh gas (CH <sub>4</sub> ).....	2.3	2.4	0.31	.....	22.6	39.5	67.0
C <sub>n</sub> H <sub>2n</sub> gases.....	nil	nil	0.31	4.0(?)	3.0	3.8	6.0
Carbonic oxide (CO).....	13.2	24.4	25.07	21.0	8.7	7.5	0.6
Nitrogen (N).....	46.8	59.4	48.98	49.5	5.8	0.5	3.0
Carbonic acid (CO <sub>2</sub> ).....	12.9	5.2	6.57	5.0	3.0	nil	0.6
Total volume.....	100.0	100.0	100.0	100.0	100.0	100.0	100.0
Total combustible gases.....	40.3	35.4	44.42	45.0	91.2	98.8	95.6
<b>Theoretical.</b>							
Air required for combustion....	112.4	101.4	113.2	154.0	410.0	581.0	806.0
Calorific value per cu. ft., } in lb. ° C. units.....	85.9	74.7	88.9	115.3	284.0	381.0	495.8
Do., B.T.U. per cu. ft.....	154.6	134.5	160.0	207.5	511.2	658.8	892.4
Do., per litre, gram ° C. units ...	1,374	1,195	1,432	1,845	4,544	6,096	7,932

NOTE. — Where the volume per cent does not add up to 100 the slight difference is due to the presence of oxygen.

The following is the analysis of gas made in a Mond producer at the works of the Solvay Process Co. in Detroit, Mich. (*Mineral Industry*, vol. viii, 1900): CO<sub>2</sub>, 14.1; O, 0.3; N, 42.9; H, 25.9; CH<sub>4</sub>, 4.1; CO, 12.7. Combustible, 42.7%. Calories per litre, 1540, = 173 B.T.U. per cu. ft.

**Relative Efficiencies of Different Coals in Gas Producer and Engine Tests.** — The following is a condensed statement of the principal results obtained in the gas-producer tests of the U. S. Geological Survey at St. Louis in 1904. (R. H. Fernald, *Trans. A. S. M. E.*, 1905.)

Sample.	B.t.u. per lb. combustible.	Pounds per electrical H.P. hour at switchboard.			Sample.	B.t.u. per lb. combustible.	Pounds per electrical H.P. hour at switchboard.		
		Coal as fired.	Dry coal.	Combustible.			Coal as fired.	Dry coal.	Combustible.
Ala. No. 2...	14820	1.71	1.64	1.53	Ky. No. 3..	14650	2.05	1.91	1.72
Colo. No. 3...	13210	2.14	1.71	1.58	Mo. No. 2..	14280	1.94	1.71	1.43
Ill. No. 3.....	14560	1.93	1.79	1.60	Mont. No. 1	13580	2.54	2.25	1.98
Ill. No. 4.....	14344	2.01	1.76	1.57	N.Dak.No.2	12600	3.80	2.29	2.05
Ind. No. 1....	14720	2.17	1.93	1.71	Texas No. 1	12945	3.34	2.22	1.88
Ind. No. 2....	14500	1.68	1.55	1.39	Texas No. 2	12450	2.58	1.71	1.52
Okla. No. 1...	14800	1.92	1.83	1.66	W.Va. No. 1	15350	1.60	1.57	1.48
Okla. No. 4...	13890	1.57	1.43	1.17	W.Va. No. 4	15600	1.32	1.29	1.17
Iowa No. 2...	13950	2.07	1.73	1.30	W.Va. No. 7	15800	1.53	1.50	1.40
Kan. No. 5...	15200	1.69	1.62	1.43	Wyo. No. 2	13820	2.28	2.07	1.60

The gas was made in a Taylor pressure producer rated at 250 H.P. Its inside diam. was 7 ft., area of fuel bed 38.5 sq. ft., height of casing 15 ft.; rotative ash table; centrifugal tar extractor. The engine was a 3-cylinder



vertical Westinghouse, 19 in. diam., 22 in. stroke, 200 r.p.m., rated at 235 B. H. P. Comparing the results of the W. Va. No. 7 coal, the best on the list, with the North Dakota coal, the one which gave the poorest results, the heat values per lb. combustible of the coals are as 1 to 0.808; reciprocal, 1 to 1.24; the lbs. combustible per E. H. P. hour as 1 to 1.75, and lbs. coal as fired per E. H. P. hour as 1 to 2.88. The relative thermal efficiencies of the engine with the two coals are as 2.05 to 1.17, or as 1 to 0.578. The analyses by volume of the dry gas obtained from the two coals was:

	CO <sub>2</sub>	O	CO	H	CH <sub>4</sub>	N	Total combustible.
W. Va.....	10.16	0.24	15.82	11.16	3.74	58.88	30.72
N. Dak.....	8.69	0.23	20.90	14.33	4.85	51.00	40.06

The dry-gas analysis shows the North Dakota gas to be by far the best; its much lower result in the engine test is due to the smaller quantity of gas produced per lb. of coal, which was 22.7 cu. ft. per lb. of coal as fired, as compared with 70.6 cu. ft. for the W. Va. coal, measured at 62° F. and 14.7 lb. absolute pressure.

**Use of Steam in Producers and in Boiler-furnaces.** (R. W. Raymond, *Trans. A. I. M. E.*, xx, 635.) — No possible use of steam can cause a gain of heat. If steam be introduced into a bed of incandescent carbon it is decomposed into hydrogen and oxygen.

The heat absorbed by the reduction of one pound of steam to hydrogen is much greater in amount than the heat generated by the union of the oxygen thus set free with carbon, forming either carbonic oxide or carbonic acid. Consequently, the effect of steam alone upon a bed of incandescent fuel is to chill it. In every water-gas apparatus, designed to produce by means of the decomposition of steam a fuel-gas relatively free from nitrogen, the loss of heat in the producer must be compensated by some reheating device.

This loss may be recovered if the hydrogen of the steam is subsequently burned, to form steam again. Such a combustion of the hydrogen is contemplated, in the case of fuel-gas, as secured in the subsequent use of that gas. Assuming the oxidation of H to be complete, the use of steam will cause neither gain nor loss of heat, but a simple transference, the heat absorbed by steam decomposition being restored by hydrogen combustion. In practice, it may be doubted whether this restoration is ever complete. But it is certain that an excess of steam would defeat the reaction altogether, and that there must be a certain proportion of steam, which permits the realization of important advantages, without too great a net loss in heat.

The advantage to be secured (in boiler furnaces using small sizes of anthracite) consists principally in the transfer of heat from the lower side of the fire, where it is not wanted, to the upper side, where it is wanted. The decomposition of the steam below cools the fuel and the grate-bars, whereas a blast of air alone would produce, at that point, intense combustion (forming at first CO<sub>2</sub>), to the injury of the grate, the fusion of part of the fuel, etc.

**Gas Analyses by Volume and by Weight.** — To convert an analysis of a mixed gas by volume into analysis by weight: Multiply the percentage of each constituent gas by its relative density, viz: CO<sub>2</sub> by 11, O by 8, CO and N each by 7, and divide each product by the sum of the products. Conversely, to convert analysis by weight into analysis by volume, divide the percentage by weight of each gas by its relative density, and divide each quotient by the sum of the quotients.

**Gas-fuel for Small Furnaces.** — E. P. Reichhelm (*Am. Mach.*, Jan. 10, 1895) discusses the use of gaseous fuel for forge fires, for drop-forging, in annealing-ovens and furnaces for melting brass and copper, for case-hardening, muffle-furnaces, and kilns. Under ordinary conditions, in such furnaces he estimates that the loss by draught, radiation, and the heating of space not occupied by work is, with coal, 80%, with petroleum 70%, and with gas above the grade of producer-gas 25%. He gives the following table of comparative cost of fuels, as used in these furnaces:

Kind of Gas.	No. of Heat-units in 1000 cu. ft. used.	No. of Heat-units in Furnaces after Deducting 25% Loss.	Average Cost per 1000 Ft.	Cost of 1,000 Heat-units Obtained in Furnaces.
Natural gas.....	1,000,000	750,000		
Coal-gas, 20 candle-power.....	675,000	506,250	\$1.25	\$2.46
Carburetted water-gas.....	646,000	484,500	1.00	2.06
Gasolene gas, 20 candle-power.....	690,000	517,500	.90	1.73
Water-gas from coke.....	313,000	234,750	.40	1.70
Water-gas from bituminous coal.....	377,000	282,750	.45	1.59
Water-gas and producer-gas mixed....	185,000	138,750	.20	1.44
Producer-gas.....	150,000	112,500	.15	1.33
Naphtha-gas, fuel 2 1/2 gals. per 1000 ft..	306,365	229,774	.15	.65
Coal, \$4 per ton, per 1,000,000 heat-units utilized.....				.73
Crude petroleum, 3 cts. per gal., per 1,000,000 heat-units.....				.73

Mr. Reichhelm gives the following figures from practice in melting brass with coal and with naphtha converted into gas: 1800 lbs. of metal require 1080 lbs. of coal, at \$4.65 per ton, equal to \$2.51, or, say, 15 cents per 100 lbs. Mr. T.'s report: 2500 lbs. of metal require 47 gals. of naphtha, at 6 cents per gal., equal to \$2.82, or, say, 11 1/4 cents per 100 lbs.

**Blast-Furnace Gas.**—The waste-gases from iron blast furnaces were formerly utilized only for heating the blast in the hot-blast ovens and for raising steam for the blowing-engine pumps, hoists and other auxiliary apparatus. Since the introduction of gas engines for blowing and other purposes it has been found that there is a great amount of surplus gas available for other uses, so that a large power plant for furnishing electric current to outside consumers may easily be run by it. H. Freyn, in a paper presented before the Western Society of Engineers (*Eng. Rec.*, Jan. 13, 1906), makes an elaborate calculation for the design of such a plant in connection with two blast furnaces of a capacity of 400 tons of pig iron each per day. Some of his figures are as follows: The two furnaces would supply 4,350,000 cu. ft. of gas per hour, of 90 B.T.U. average heat value per cu. ft. The hot-blast stoves would require 30% of this, or 1,305,000 cu. ft.; the gas-blowing engines 720,000 cu. ft.; pumps, hoists and lighting machinery, 120,000 cu. ft.; gas-cleaning machinery, 120,000 cu. ft.; losses in piping, 48,000 cu. ft.; leaving available for outside uses, in round numbers, 2,000,000 cu. ft. per hour. At the rate of 100 cu. ft. of gas per brake H.P. hour this would supply engines of 20,000 H.P., but assuming that on account of irregular working of the furnaces only half this amount would be available for part of the time, a 10,000-H.P. plant could be run with the surplus gas of the two furnaces. Taking into account the cost of the plant, figured at \$61.60 per B.H.P., interest, depreciation, labor, etc., the annual cost of producing one B.H.P., 24 hours a day, is \$17.88, no value being placed on the blast-furnace gas, and 1 K.W. hour would cost 0.295 cent, which is far below the lowest figure ever reached with a steam-engine power plant.

Blast-furnace gas is composed of nitrogen, carbon dioxide and carbon monoxide, the latter being the combustible constituent. An analysis reported in *Trans. A.I.M.E.*, xvii, 50, is, by volume, CO<sub>2</sub>, 7.08; CO, 27.80; O, 0.10; N, 65.02. The relative proportions of CO<sub>2</sub> and CO vary considerably with the conditions of the furnace.

## ACETYLENE AND CALCIUM CARBIDE.

**Acetylene**, C<sub>2</sub>H<sub>2</sub>, contains 12 parts C and 1 part H, or 92.3% C, 7.7% H. It is described as follows in a paper on Calcium Carbide and Acetylene by J. M. Morehead (*Am. Gas Light Jour.*, July 10, 1905. Revised, Jan., 1915).

Acetylene is a colorless and tasteless gas. When pure it has a sweet ethereal odor, but in the commercial form it carries small percentages of phosphoreted and sulphureted hydrogen which give it a pungent odor.

Pure acetylene is without toxic or physiological effect. It may be inhaled or swallowed with impunity. One cu. ft. requires 11.91 cu. ft. of air for its complete combustion. Its specific gravity is 0.92, air being 1. It is the nearest approach to gaseous carbon, and it possesses a higher candle power and flame temperature than any other known substance, 240 candles for 5 cu. ft., 4078° F. when burned in air, 7878° F. in oxygen. Its ignition temperature with air is 804° F., with oxygen 782° F. It is soluble in its own volume of water, and in varying proportions in ether, alcohol, turpentine, and acetone. The solubility increases with pressure. It liquefies under a pressure of 700 lbs. per sq. in. at 70° F. The pressure necessary for liquefaction varies directly with the temperature up to 98°, which is its critical temperature, beyond which it is impossible to liquefy the gas at any pressure.

When calcium carbide is brought into contact with water, the calcium robs the water of its oxygen and forms lime and thus frees the hydrogen, which combines with the carbon of the carbide to form acetylene. Sixty-four lbs. of calcium carbide combine with thirty-six lbs. of water and produce twenty-six lbs. of acetylene and 74 lbs. of pure slacked lime. [The chemical reaction is  $\text{CaC}_2 + 2\text{H}_2\text{O} = \text{C}_2\text{H}_2 + \text{Ca}(\text{OH})_2$ .]

Chemically pure calcium carbide will yield at 70° F. and 30 in. mercury 5.83 cu. ft. acetylene per pound of carbide. Commercially pure carbide is guaranteed to yield 5 cu. ft. of acetylene per pound, and usually exceeds the guarantee by a few per cent. The reaction between calcium carbide and water, and the subsequent slacking of the calcium oxide produced, give rise to considerable heat. This heat from one pound of chemically pure calcium carbide amounts to sufficient to raise the temperature of 4.1 lbs. of water from the freezing to the boiling point.

There are two types of generators; one in which a varying quantity of water is dropped on to the carbide, the other in which the carbide is dropped into a large excess of water. Owing to the large amount of heat generated by the reaction, and the susceptibility of the acetylene to heat, the first, or dry type, is confined to lamps and to small machines.

Acetylene produces 1475 B.T.U. per cubic foot (at 70° F. and 30 in.), as compared with 1000 for natural gas and 600 for coal or water gas. At the present state of development of the acetylene industry and the calcium carbide manufacture, this gas will not compete with coal gas or water gas, or with electricity as supplied in our cities.

The explosive limits of acetylene and air are from 3% acetylene and 97% air to 24% acetylene and 76% air, the point of maximum explosibility being 7.7% acetylene and 92.3% air.

The combustion of acetylene requires theoretically  $2\frac{1}{2}$  volumes of oxygen for 1 volume of acetylene. In autogenous welding and other oxy-acetylene processes, however, a considerable part of the necessary oxygen is taken from the air, and hence only from 1.25 to 1.75 cubic feet of oxygen per cubic foot of acetylene need be supplied.

Of the 1475 heat units contained in a cubic foot of acetylene, 227 are endothermic energy, which it is believed is higher than that for any other substance. The balance of the energy is derived from the combination of the carbon and hydrogen of the acetylene with oxygen, as is the case with other combustible gases.

Due to the extraordinary endothermic energy of acetylene the gas will explode of itself if it is ignited while at a pressure slightly in excess of 15 lbs. to the square inch. The compression, storage, use and transportation of unabsorbed acetylene at pressures in excess of this figure are forbidden by the fire, police, insurance and transportation authorities in practically all cities. Danger of explosion from compressed acetylene is removed and the use of compressed acetylene is rendered safe and feasible for motor car, yacht, railroad train and all other portable uses by absorbing the acetylene in acetone, which is itself absorbed in turn in asbestos, Keisselgour or other non-inflammable substances.

Calcium carbide was discovered on May 4, 1892, at the plant of the Willson Aluminum Co., in North Carolina. It is a crystalline body, hard, brittle and varying in color from almost black to brick red. Its specific gravity is 2.26. A cubic foot of crushed carbide weighs 138 lbs., and in weight, color and most of its physical characteristics is about like granite. If broken hot, the fracture shows a handsome, bluish purple iridescence and the crystals are apt to be quite large.



Calcium carbide,  $\text{CaC}_2$ , contains 62.5% Ca and 37.5% C. It is insoluble in most acids and in all alkalis; it is non-inflammable, infusible, non-explosive, unaffected by jars, concussions or time, and, except for the property of giving off acetylene when brought in contact with water, it is an inert and stable body. It is made by the reduction in an electric arc furnace of a mixture of finely pulverized and intimately mixed calcium oxide or quicklime and carbon in the shape of coke ( $\text{CaO} + 3\text{C} = \text{CaC}_2 + \text{CO}$ ). The furnaces employ from 12,000 to 15,000 electric H.P. each and produce from 50 to 75 tons per day. The output is crushed to different sizes and it is sold in steel drums for \$70 per ton at the works.

The entire use for calcium carbide is for the production of acetylene. [Wohler, in 1862, obtained calcium carbide by heating an alloy of calcium and zinc together with carbon to a very high temperature.]

**Acetylene Generators and Burners.**—Lewes classifies acetylene generators under four types: (1) Those in which water drips or flows slowly on a mass of carbide; (2) those in which water rises, coming in contact with a mass of carbide; (3) those in which water rises, coming in contact with successive layers of carbide; (4) those in which the carbide is dropped or plunged into an excess of water. He shows that the first two classes are dangerous; that some generators of the third class are good, but that those of the fourth are the best.

Of the various burners used for acetylene, those of the Naphey type are among the most satisfactory. Two tubes leading from the base of the burner are so adjusted as to cause two jets of flame to impinge upon each other at some little distance from the nozzles, and mutually to splay each other out into a flat flame. The tips of the nozzles, usually of steatite, are formed on the principle of the Bunsen burner, insuring a thorough mixture of the acetylene with enough air to give the best illumination. (H. C. Biddle, *Cal. Jour. of Tech.*, 1907.)

Acetylene gas is an endothermic compound. In its formation heat is absorbed, and there resides in the acetylene molecule the power of spontaneously decomposing and liberating this heat if it is subjected to a temperature or pressure beyond the capacity of its unstable nature to withstand. (Thos. L. White, *Eng. Mag.*, Sept., 1908.) Mr. White recommends the use of acetylene for carbureting the alcohol used in alcohol motors for automobiles.

**The Acetylene Blowpipe.**—(*Machy.*, July, 1907.)—The acetylene is produced in a generator and stored in a tank at a pressure of 2.2 to 3 lbs. per sq. in. The oxygen is compressed in a tank at about 150 lbs. pressure. The acetylene is conveyed to the burner through a 1-in. pipe with one  $\frac{3}{8}$ -in. branch leading to each blowpipe connection. The oxygen is conveyed through  $\frac{3}{8}$ -in. pipe with  $\frac{1}{4}$ -in. branches. The blowpipe is of brass, made on the injector principle. As acetylene is so rich in carbon—containing 92.3%—it is possible, when mixed with air in a Bunsen burner, to obtain  $3100^\circ \text{F.}$ , and when combined with oxygen,  $6300^\circ \text{F.}$ , which is the hottest flame known as a product of combustion, and nearly equals the electric arc. This is about  $1200^\circ$  higher than the oxygen-hydrogen blowpipe flame.

In lighting the blowpipe, the acetylene is first turned on full; then the oxygen is added until the flame is only a single cone. At the apex of this cone is a temperature of  $6300^\circ \text{F.}$  In welding, this point is held from  $\frac{1}{8}$  to  $\frac{1}{4}$  in. distant from the metal to be welded. Too much acetylene produces two cones and a white color; an excess of oxygen is indicated by a violet tint.

Theoretically,  $2\frac{1}{2}$  volumes of oxygen are required for complete combustion of 1 volume of acetylene. Practically, however, with the blowpipe, the best welding results are obtained with 1.7 volumes of oxygen to 1 volume of acetylene. The acetylene is, therefore, not completely burned with the blowpipe, according to the reaction:

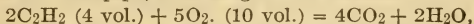

but it is incompletely burned according to the reaction:

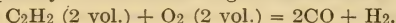

The Theory and Practice of Oxy-Acetylene Welding is described in an illustrated article by J. F. Springer in *Indust. Eng'g.*, Oct., 1909.

The Levoisite process of making oxygen (99.9% pure), used in acety-

lene welding, is described by Max Mauran in *Met. and Chem. Eng'g.*, June, 1914.

### IGNITION TEMPERATURE OF GASES.

Mayer and Münch (*Bericht der deutscher Gesellschaft*, xxvi, 2241) give the following:

Marsh-gas,	$C_2H_4$ ,	667° C.	1233° F.
Ethane,	$C_2H_6$ ,	616	1141
Propane,	$C_3H_8$ ,	547	1017
Acetylene,	$C_2H_2$ ,	580	1076
Propylene,	$C_3H_6$ ,	504	939

Very different figures are given by other authorities. A French Commission obtained for hydrogen 1071° F.;  $CH_4$ , 1436°;  $C_2H_4$ , 1022°; CO, 1202; CO in presence of a large quantity of  $CO_2$ , 1292° F. Vivian Lewes gives for the ignition temperature of cannel coal 668° F.; bituminous, 766°, semi-bituminous 870° F. W. S. Hutton gives for anthracite, 925° F.

### ILLUMINATING-GAS.

**Coal-gas** is made by distilling bituminous coal in retorts. The retort is usually a long horizontal semi-cylindrical or  $\square$  shaped chamber, holding from 160 to 300 lbs. of coal. The retorts are set in "benches" of from 3 to 9, heated by one fire, which is generally of coke. The vapors distilled from the coal are converted into a fixed gas by passing through the retort, which is heated almost to whiteness.

The gas passes out of the retort through an "ascension-pipe" into a long horizontal pipe called the hydraulic main, where it deposits a portion of the tar it contains; thence it goes into a condenser, a series of iron tubes surrounded by cold water, where it is freed from condensable vapors, as ammonia-water, then into a washer, where it is exposed to jets of water, and into a scrubber, a large chamber partially filled with trays made of wood or iron, containing coke, fragments of brick or paving-stones, which are wet with a spray of water. By the washer and scrubber the gas is freed from the last portion of tar and ammonia and from some of the sulphur compounds. The gas is then finally purified from sulphur compounds by passing it through lime or oxide of iron. The gas is drawn from the hydraulic main and forced through the washer, scrubber, etc., by an exhauster or gas pump.

The kind of coal used is generally caking bituminous, but as usually this coal is deficient in gases of high illuminating power, there is added to it a portion of cannel coal or other enricher.

The following table, abridged from one in Johnson's *Cyclopedia*, shows the analysis, candle-power, etc., of some gas-coals and enrichers:

Gas-coals, etc.	Vol. Matter.	Fixed Carb.	Ash.	Gas per ton of 2240 lbs. in cu. ft.	Cand.-power of Gas.	Coke per ton of 2240 lbs.		Gas purified by 1 bush. of lime, in cu. ft.
						lbs.	bush.	
Pittsburgh, Pa.....	36.76	51.93	7.07	.....	.....	.....	.....	.....
Westmoreland, Pa.....	36.00	58.00	6.00	10,642	16.62	1544	40	6420
Sterling, O.....	37.50	56.90	5.60	10,528	18.81	1480	36	3993
Despard, W. Va.....	40.00	53.30	6.70	10,765	20.41	1540	36	2494
Darlington, O.....	43.00	40.00	17.00	9,800	34.98	1320	32	2806
Petonia, W. Va.....	46.00	41.00	13.00	13,200	42.79	1380	32	4510
Grahamite, W. Va.....	53.50	44.50	2.00	15,000	28.70	1056	44	.....

The products of the distillation of 100 lbs. of average gas-coal are about as follows. They vary according to the quality of coal and the temperature of distillation.

Coke, 64 to 65 lbs.; tar, 6.5 to 7.5 lbs.; ammonia liquor, 10 to 12 lbs.; purified gas, 15 to 12 lbs.; impurities and loss, 4.5% to 3.5%.

The composition of the gas by volume ranges about as follows: Hydro-

gen, 38% to 48%; carbonic oxide, 2% to 14%; marsh-gas (Methane,  $\text{CH}_4$ ), 43% to 31%; heavy hydrocarbons ( $\text{C}_n\text{H}_{2n}$ , ethylene, propylene, benzole vapor, etc.), 7.5% to 4.5%; nitrogen, 1% to 3%.

In the burning of the gas the nitrogen is inert; the hydrogen and carbonic oxide give heat but no light. The luminosity of the flame is due to the decomposition by heat of the heavy hydrocarbons into lighter hydrocarbons and carbon, the latter being separated in a state of extreme subdivision. By the heat of the flame this separated carbon is heated to intense whiteness, and the illuminating effect of the flame is due to the light of incandescence of the particles of carbon.

The attainment of the highest degree of luminosity of the flame depends upon the proper adjustment of the proportion of the heavy hydrocarbons (with due regard to their individual character) to the nature of the diluent mixed therewith.

Investigations of Percy F. Frankland show that mixtures of ethylene and hydrogen cease to have any luminous effect when the proportion of ethylene does not exceed 10% of the whole. Mixtures of ethylene and carbonic oxide cease to have any luminous effect when the proportion of the former does not exceed 20%, while all mixtures of ethylene and marsh-gas have more or less luminous effect. The luminosity of a mixture of 10% ethylene and 90% marsh-gas being equal to about 18 candles, and that of one of 20% ethylene and 80% marsh-gas about 25 candles. The illuminating effect of marsh-gas alone, when burned in an argand burner, is by no means inconsiderable.

For further description, see the treatises on gas by King, Richards, and Hughes; also Appleton's *Cyc. Mech.*, vol. i. p. 900.

**Water-gas.** — Water-gas is obtained by passing steam through a bed of coal, coke, or charcoal heated to redness or beyond. The steam is decomposed, its hydrogen being liberated and its oxygen burning the carbon of the fuel, producing carbonic-oxide gas. The chemical reaction is,  $\text{C} + \text{H}_2\text{O} = \text{CO} + 2\text{H}$ , or  $2\text{C} + 2\text{H}_2\text{O} = \text{C} + \text{CO}_2 + 4\text{H}$ , followed by a splitting up of the  $\text{CO}_2$ , making  $2\text{CO} + 4\text{H}$ . By weight the normal gas  $\text{CO} + 2\text{H}$  is composed of  $\text{C} + \text{O} + \text{H} = 28$  parts  $\text{CO}$  and 2 parts  $\text{H}$ ,

$$12 + 16 + 2$$

or 93.33%  $\text{CO}$  and 6.67%  $\text{H}$ ; by volume it is composed of equal parts of carbonic oxide and hydrogen. Water-gas produced as above described has great heating-power, but no illuminating-power. It may, however, be used for lighting by causing it to heat to whiteness some solid substance, as is done in the Welsbach incandescent light.

An illuminating-gas is made from water-gas by adding to it hydrocarbon gases or vapors, which are usually obtained from petroleum or some of its products. A history of the development of modern illuminating water-gas processes, together with a description of the most recent forms of apparatus, is given by Alex. C. Humphreys, in a paper on "Water-gas in the United States," read before the Mechanical Section of the British Association for Advancement of Science, in 1889. After describing many earlier patents, he states that success in the manufacture of water-gas may be said to date from 1874, when the process of T. S. C. Lowe was introduced. All the later most successful processes are the modifications of Lowe's, the essential features of which were "an apparatus consisting of a generator and superheater internally fired; the superheater being heated by the secondary combustion from the generator, the heat so stored up in the loose brick of the superheater being used, in the second part of the process, in the fixing or rendering permanent of the hydrocarbon gases; the second part of the process consisting in the passing of steam through the generator fire, and the admission of oil or hydrocarbon at some point between the fire of the generator and the loose filling of the superheater."

The water-gas process thus has two periods: first the "blow," during which air is blown through the bed coal in the generator, and the partially burned gaseous products are completely burned in the superheater, giving up a great portion of their heat to the fire-brick work contained in it, and then pass out to a chimney; second, the "run" during which the air blast is stopped, the opening to the chimney closed, and steam is blown through the incandescent bed of fuel. The resulting water-gas passing into the carburetting chamber in the base of the superheater is there charged with hydrocarbon vapors, or spray (such as naphtha and other distillates or crude oil), and passes through the superheater, where



the hydrocarbon vapors become converted into fixed illuminating gases. From the superheater the combined gases are passed, as in the coal-gas process, through washers, scrubbers, etc., to the gas-holder. In this case, however, there is no ammonia to be removed.

The specific gravity of water-gas increases with the increase of the heavy hydrocarbons which give illuminating power. The following figures, taken from different authorities, are given by F. H. Shelton in a paper on "Water-gas," read before the Ohio Gas Light Association, in 1894:

Candle-power.... 19.5 20. 22.5 24. 25.4 26.3 28.3 29.6 .30 to 31.9  
Sp. gr. (Air=1).. .571 .630 .589 .60 to .67 .64 .602 .70 .65 .65 to .71

#### Analyses of Water-gas and Coal-gas Compared.

The following analyses are taken from a report of Dr. Gideon E. Moore on the Granger Water-gas, 1885:

	Composition by Vol.			Composition by Weight.		
	Water-gas.		Coal-gas. Heidel- berg.	Water-gas.		Coal-gas.
	Wor- cester.	Lake.		Wor- cester.	Lake.	
Nitrogen.....	2.64	3.85	2.15	0.04402	0.06175	0.04559
Carbonic acid.....	0.14	0.30	3.01	0.00365	0.00753	0.09992
Oxygen.....	0.06	0.01	0.65	0.00114	0.00018	0.01569
Ethylene.....	11.29	12.80	2.55	0.18759	0.20454	0.05389
Propylene.....	0.00	0.00	1.21			0.03834
Benzole vapor.....	1.53	2.63	1.33	0.07077	0.11700	0.07825
Carbonic oxide.....	28.26	23.58	8.88	0.46934	0.37664	0.18758
Marsh-gas.....	18.88	20.95	34.02	0.17928	0.19133	0.41087
Hydrogen.....	37.20	35.88	46.20	0.04421	0.04103	0.06987
	100.00	100.00	100.00	1.00000	1.00000	1.00000
Density: Theory.....	0.5825	0.6057	0.4580			
Practice.....	0.5915	0.6018				
B.T.U. from 1 cu. ft.:						
Water liquid.....	650.1	688.7	642.0			
" vapor.....	597.0	646.6	577.0			
Flame-temperature, °F ...	5311.2	5281.1	5202.9			
Average candle-power.....	22.06	26.31				

The heating-values (B.T.U.) of the gases are calculated from the analysis by weight, by using the multipliers given below (computed from results of J. Thomsen), and multiplying the result by the weight of 1 cu. ft. of the gas at 62° F., and atmospheric pressure.

The flame-temperatures (theoretical) are calculated on the assumption of complete combustion of the gases in air, without excess of air.

The candle-power was determined by photometric tests, using a pressure of 1/2-in. water-column, a candle consumption of 120 grains of spermaceti per hour, and a meter rate of 5 cu. ft. per hour, the result being corrected for a temperature at 62° F. and a barometric pressure of 30 in. It appears that the candle-power may be regulated at the pleasure of the person in charge of the apparatus, the range of candle-power being from 20 to 29 candles, according to the manipulation employed.

#### Calorific Equivalents of Constituents of Illuminating-gas.

	Heat-units from 1 lb.		Heat-units from 1 lb.	
	Water Liquid.	Water Vapor.	Water Liquid.	Water Vapor.
Ethylene.....	21,524.4	20,134.8	Carbonic oxide .	4,395.6
Propylene.....	21,222.0	19,834.2	Marsh-gas.....	24,021.0
Benzole vapor.	18,954.0	17,847.0	Hydrogen.....	61,524.0
				51,804.0

**Efficiency of a Water-gas Plant.**—The practical efficiency of an illuminating water-gas setting is discussed in a paper by A. G. Glasgow (*Proc. Am. Gaslight Assn.*, 1890) from which the following is abridged:

The results refer to 1000 cu. ft. of unpurified carburetted gas, reduced to 60° F. The total anthracite charged per 1000 cu. ft. of gas was 33.4 lbs., ash and unconsumed coal removed, 9.9 lbs., leaving total combustible consumed, 23.5 lbs., which is taken to have a fuel-value of 14,500 B.T.U. per pound, or a total of 340,750 heat-units.

		Com- posi- tion by Vol.	Weight per 100 Cu. Ft.	Com- posi- tion by W'ht.	Specific Heat.	
I. Carburetted Water-gas..	{	CO <sub>2</sub> + H <sub>2</sub> S	3.8	.465842	0.09647	0.02088
		C <sub>n</sub> H <sub>2n</sub> . . . . .	14.6	1.139968	.23607	.08720
		CO . . . . .	28.0	2.1868	.45285	.11226
		CH <sub>4</sub> . . . . .	17.0	.75854	.15710	.09314
		H . . . . .	35.6	.1991464	.04124	.14041
		N . . . . .	1.0	.078596	.01627	.00397
		100.0	4.8288924	1.00000	.45786	
II. Uncarburetted gas . . . . .	{	CO <sub>2</sub> . . . . .	3.5	.429065	.1019	.02205
		CO . . . . .	43.4	3.389540	.8051	.19958
		H . . . . .	51.8	.289821	.0688	.23424
		N . . . . .	1.3	.102175	.0242	.00591
		100.0	4.210601	1.0000	.46178	
III. Blast products escap- ing from superheater..	{	CO <sub>2</sub> . . . . .	17.4	2.133066	.2464	.05342
		O . . . . .	3.2	.2856096	.0329	.00718
		N . . . . .	79.4	6.2405224	.7207	.17585
			100.0	8.6591980	1.0000	.23645
IV. Generator blast-gases..	{	CO <sub>2</sub> . . . . .	9.7	1.189123	.1436	.031075
		CO . . . . .	17.8	1.390180	.1680	.041647
		N . . . . .	72.5	5.698210	.6884	.167970
			100.0	8.277513	1.0000	.240692

The heat-energy absorbed by the apparatus is  $23.5 \times 14,500 = 340,750$  heat-units = *A*. Its disposition is as follows:

*B*, the energy of the CO produced;

*C*, the energy absorbed in the decomposition of the steam;

*D*, the difference between the sensible heat of the escaping illuminating-gases and that of the entering oil;

*E*, the heat carried off by the escaping blast products;

*F*, the heat lost by radiation from the shells;

*G*, the heat carried away from the shells by convection (air-currents);

*H*, the heat rendered latent in the gasification of the oil;

*I*, the sensible heat in the ash and unconsumed coal recovered from the generator.

The heat equation is  $A = B + C + D + E + F + G + H + I$ : *A* being known. A comparison of the CO in Tables I and II show that  $\frac{280}{434}$ ,

or 64.5% of the volume of carburetted gas, is pure water-gas, distributed thus: CO<sub>2</sub>, 2.3%; CO, 28.0%; H, 33.4%; N, 0.8%; = 64.5%. 1 lb. of CO at 60° F. = 13,531 cu. ft. CO per 1000 cu. ft. of gas =  $280 \div 13.531 = 20.694$  lbs. Energy of the CO =  $20.694 \times 4395.6 = 91,043$  heat-units = *B*. 1 lb. of H at 60° F. = 189.2 cu. ft. H per M of gas =  $334 \div 189.2 = 1.7653$  lbs. Energy of the H per lb. (according to Thomsen, considering the steam generated by its combustion to be condensed to water at 75° F.) = 61,524 B.T.U. In Mr. Glasgow's experiments the steam entered the generator at 331° F.; the heat required to raise the product of combustion of 1 lb. of H, viz., 8.98 lbs. H<sub>2</sub>O, from water at 75° to steam at 331° must therefore be deducted from Thomsen's figure, or  $61,524 - (8.98 \times 1140.2) = 51,285$  B.T.U. per lb. of H. Energy of the H, then, is  $1.7653 \times 51,285 = 90,533$  heat-units = *C*. The best

lost due to the sensible heat in the illuminating-gases, their temperature being  $1450^{\circ}\text{F.}$ , and that of the entering oil  $235^{\circ}\text{F.}$ , is  $48.29$  (weight)  $\times .45786$  (sp. heat)  $\times 1215$  (rise of temperature) =  $26,864$  heat-units =  $D$ .  
 (The specific heat of the entering oil is approximately that of the issuing gas.)

The heat carried off in 1000 cu. ft. of the escaping blast products is  $86.592$  (weight)  $\times .23645$  (sp. heat)  $\times 1474^{\circ}$  (rise of temp.) =  $30,180$  heat-units: the temperature of the escaping blast gases being  $1550^{\circ}\text{F.}$ , and that of the entering air  $76^{\circ}\text{F.}$  But the amount of the blast gases, by registration of an anemometer, checked by a calculation from the analyses of the blast gases, was  $2457$  cubic feet for every 1000 cubic feet of carburetted gas made. Hence the heat carried off per M. of carburetted gas is  $30,180 \times 2.457 = 74,152$  heat-units =  $E$ .

Experiments made by a radiometer covering four square feet of the shell of the apparatus gave figures for the amount of heat lost by radiation =  $12,454$  heat-units =  $F$ , and by convection =  $15,696$  heat-units =  $G$ .

The heat rendered latent by the gasification of the oil was found by taking the difference between all the heat fed into the carburetter and superheater and the total heat dissipated therefrom to be  $12,841$  heat-units =  $H$ . The sensible heat in the ash and unconsumed coal is  $9.9$  lbs.  $\times 1500^{\circ}$   $\times .25$  (sp. ht.) =  $3712$  heat-units =  $I$ .

The sum of all the items  $B + C + D + E + F + G + H + I = 327,295$  heat-units, which subtracted from the heat-energy of the combustible consumed,  $340,750$  heat-units, leaves  $13,455$  heat-units, or 4 per cent unaccounted for.

Of the total heat-energy of the coal consumed, or  $340,750$  heat-units, the energy wasted is the sum of items  $D, E, F, G,$  and  $I$ , amounting to  $132,878$  heat-units, or 39 per cent; the remainder, or  $207,872$  heat-units, or 61 per cent, being utilized. The efficiency of the apparatus as a heat machine is therefore 61 per cent.

Five gallons, or 35 lbs. of crude petroleum, were fed into the carburetter per 1000 cu. ft. of gas made; deducting 5 lbs. of tar recovered, leaves 30 lbs.  $\times 20,000 = 600,000$  heat-units as the net heating-value of the petroleum used. Adding this to the heating-value of the coal,  $340,750$  B.T.U., gives  $940,750$  heat-units, of which there is found as heat-energy in the carburetted gas, as in the table below,  $764,050$  heat-units, or 81 per cent, which is the commercial efficiency of the apparatus, i.e., the ratio of the energy contained in the finished product to the total energy of the coal and oil consumed.

The heating-power per M. cu. ft. of the carburetted gas is		The heating-power per M. of the uncarburetted gas is	
CO <sub>2</sub>	38.0	CO <sub>2</sub>	35.0
C <sub>3</sub> H <sub>8</sub> *	$146.0 \times .117220 \times 21222.0 = 363200$	CO	$434.0 \times .078100 \times 4395.6 = 148991$
CO	$280.0 \times .078100 \times 4395.6 = 96120$	H	$518.0 \times .005594 \times 61524.0 = 178277$
CH <sub>4</sub>	$170.0 \times .044620 \times 24021.0 = 182210$	N	13.0
H	$356.0 \times .005594 \times 61524.0 = 122520$		
N	10.0		
	<hr/>		<hr/>
	1000.0		1000.0
	<hr/>		<hr/>
	764050		327268

The candle-power of the gas is 31, or 6.2 candle-power per gallon of oil used. The calculated specific gravity is .6355, air being 1.

For description of the operation of a modern carburetted water-gas plant, see paper by J. Stelfox, *Eng'g*, July 20, 1894, p. 89.

**Space Required for a Water-gas Plant.** — Mr. Shelton, taking 15 modern plants of the form requiring the most floor-space, figures the average floor-space required per 1000 cubic feet of daily capacity as follows:

Water-gas Plants of Capacity in 24 hours of	Require an Area of Floor-space for each 1000 cu. ft. of about
100,000 cubic feet	4 square feet.
200,000 " "	3.5 " "
400,000 " "	2.75 " "
600,000 " "	2 to 2.5 sq. ft.
7 to 10 million cubic feet	1.25 to 1.5 sq. ft.

\* The heating-value of the illuminants  $C_nH_{2n}$  is assumed to equal that of  $C_3H_8$ .



These figures include scrubbing and condensing rooms, but not boiler and engine rooms. In coal-gas plants of the most modern and compact forms one with 16 benches of 9 retorts each, with a capacity of 1,500,000 cubic feet per 24 hours, will require 4.8 sq. ft. of space per 1000 cu. ft. of gas, and one of 6 benches of 6 retorts each, with 300,000 cu. ft. capacity per 24 hours, will require 6 sq. ft. of space per 1000 cu. ft. The storage-room required for the gas-making materials is: for coal-gas, 1 cubic foot of room for every 232 cubic feet of gas made; for water-gas made from coke, 1 cubic foot of room for every 373 cu. ft. of gas made; and for water-gas made from anthracite, 1 cu. ft. of room for every 645 cu. ft. of gas made.

The comparison is still more in favor of water-gas if the case is considered of a water-gas plant added as an auxiliary to an existing coal-gas plant; for, instead of requiring further space for storage of coke, part of that already required for storage of coke produced and not at once sold can be cut off, by reason of the water-gas plant creating a constant demand for more or less of the coke so produced.

Mr. Shelton gives a calculation showing that a water-gas of 0.625 sp. gr. would require gas-mains eight per cent greater in diameter than the same quantity coal-gas of 0.425 sp. gr. if the same pressure is maintained at the holder. The same quantity may be carried in pipes of the same diameter if the pressure is increased in proportion to the specific gravity. With the same pressure the increase of candle-power about balances the decrease of flow. With five feet of coal-gas, giving, say, eighteen candle-power, 1 cubic foot equals 3.6 candle-power; with water-gas of 23 candle-power, 1 cubic foot equals 4.6 candle-power, and 4 cubic feet gives 18.4 candle-power, or more than is given by 5 cubic feet of coal-gas. Water-gas may be made from oven-coke or gas-house coke as well as from anthracite coal. A water-gas plant may be conveniently run in connection with a coal-gas plant, the surplus retort coke of the latter being used as the fuel of the former.

In coal-gas making it is impracticable to enrich the gas to over twenty candle-power without causing too great a tendency to smoke, but water-gas of as high as thirty candle-power is quite common. A mixture of coal-gas and water-gas of a higher C.P. than 20 can be advantageously distributed.

**Fuel-value of Illuminating-gas.** — E. G. Love (*School of Mines Qlty*, January, 1892) describes F. W. Hartley's calorimeter for determining the calorific power of gases, and gives results obtained in tests of the carbureted water-gas made by the municipal branch of the Consolidated Co. of New York. The tests were made from time to time during the past two years, and the figures give the heat-units per cubic foot at 60° F. and 30 inches pressure: 715, 692, 725, 732, 691, 738, 735, 703, 734, 730, 731, 727. Average, 721 heat-units. Similar tests of mixtures of coal- and water-gases made by other branches of the same company give 694, 715, 684, 692, 727, 665, 695, and 686 heat-units per foot, or an average of 694.7. The average of all these tests was 710.5 heat-units, and this we may fairly take as representing the calorific power of the illuminating gas of New York. One thousand feet of this gas, costing \$1.25, would therefore yield 710,500 heat-units, which would be equivalent to 568,400 heat-units for \$1.00.

The common coal-gas of London, with an illuminating power of 16 to 17 candles, has a calorific power of about 668 units per foot, and costs from 60 to 70 cents per thousand.

The product obtained by decomposing steam by incandescent carbon, as effected in the Motay process, consists of about 40% of CO, and a little over 50% of H.

This mixture would have a heating-power of about 300 units per cubic foot, and if sold at 50 cents per 1000 cubic feet would furnish 600,000 units for \$1.00, as compared with 568,400 units for \$1.00 from illuminating gas at \$1.25 per 1000 cubic feet. This illuminating-gas if sold at \$1.15 per thousand would therefore be a more economical heating agent than the fuel-gas mentioned, at 50 cents per thousand, and be much more advantageous than the latter, in that one main, service, and meter could be used to furnish gas for both lighting and heating.

A large number of fuel-gases tested by Mr. Love gave from 184 to 470 heat-units per foot, with an average of 309 units.

Taking the cost of heat from illuminating-gas at the lowest figure given

by Mr. Love, viz., \$1.00 for 600,000 heat-units, it is a very expensive fuel, equal to coal at \$40 per ton of 2000 lbs., the coal having a calorific power of only 12,000 heat-units per pound, or about 83% of that of pure carbon.

$$600,000 : (12,000 \times 2000) :: \$1 : \$40.$$

**FLOW OF GAS IN PIPES.**

The rate of flow of gases of different densities, the diameter of pipes required, etc., are given in King's Treatise on Coal Gas, vol. ii, 374, as follows:

$$\left. \begin{array}{l} \text{If } d = \text{diameter of pipe in inches,} \\ Q = \text{quantity of gas in cu. ft. per} \\ \text{hour,} \\ l = \text{length of pipe in yards,} \\ h = \text{pressure in inches of water,} \\ s = \text{specific gravity of gas, air} \\ \text{being 1,} \end{array} \right\} \begin{array}{l} d = \sqrt[5]{\frac{Q^2sl}{(1350)^2h}}, \\ h = \frac{Q^2sl}{(1350)^2d^5}, \\ Q = 1350d^2 \sqrt{\frac{dh}{sl}} = 1350 \sqrt{\frac{d^5h}{sl}}. \end{array}$$

Molesworth gives  $Q = 1000 \sqrt{\frac{d^5h}{sl}}$ .

J. P. Gill, *Am. Gas-light Jour.*, 1894, gives  $Q = 1291 \sqrt{\frac{d^5h}{s(l+d)}}$ .

This formula is said to be based on experimental data, and to make allowance for obstructions by tar, water, and other bodies tending to check the flow of gas through the pipe.

King's formula translated into the form of the common formula for the flow of compressed air or steam in pipes,  $Q = c \sqrt{(p_1 - p_2) d^5/wL}$ , in which  $Q =$  cu. ft. per min.,  $p_1 - p_2 =$  difference in pressure in lbs. per sq. in.;  $w =$  density in lbs. per cu. ft.,  $L =$  length in ft.,  $d =$  diam. in ins., gives 56.6 for the value of the coefficient  $c$ , which is nearly the same as that commonly used (60) in calculations of the flow of air in pipes. For values of  $c$  based on Darcy's experiments on flow of water in pipes see Flow of Steam.

An experiment made by Mr. Clegg, in London, with a 4-in. pipe, 6 miles long, pressure 3 in. of water, specific gravity of gas 0.398, gave a discharge into the atmosphere of 852 cu. ft. per hour, after a correction of 33 cu. ft. was made for leakage.

Substituting this value, 852 cu. ft., for  $Q$  in the formula  $Q = C \sqrt{d^5h \div sl}$ , we find  $C$ , the coefficient, = 997, which corresponds nearly with the formula given by Molesworth.

Wm. Cox (*Am. Mach.*, Mar. 20, 1902) gives the following formula for flow of gas in long pipes.

$$Q = 3000 \sqrt{\frac{d^5 \times (p_1^2 - p_2^2)}{l}} = 41.3 \sqrt{\frac{d^5 \times (p_1^2 - p_2^2)}{L}}$$

$Q =$  discharge in cu. ft. per hour at atmospheric pressure;  $d =$  diam. of pipe in ins.;  $p_1 =$  initial and  $p_2 =$  terminal absolute pressure, lbs. per sq. in.;  $l =$  length of pipe in feet,  $L =$  length in miles. For  $p_1^2 - p_2^2$  may be substituted  $(p_1 + p_2)(p_1 - p_2)$ . The specific gravity of the gas is assumed to be 0.65, air being 1. For fluids of any other sp. gr.,  $s$ , multiply the coefficients 3000 or 41.3 by  $\sqrt{0.65/s}$ . For air,  $s = 1$ , the coefficients become 2419 and 33.3. J. E. Johnson Jr.'s formula for air, page 619, translated into the same notation as Mr. Cox's, makes the coefficients 2449 and 33.5.

**Services for Lamps. (Molesworth.)**

Lamps.	Ft. from Main.	Require Pipe-bore.	Lamps.	Ft. from Main.	Require Pipe-bore.
2.....	40	3/8 in.	15.....	130	1 in.
4.....	40	1/2 in.	20.....	150	1 1/4 in.
6.....	50	5/8 in.	25.....	180	1 1/2 in.
10.....	100	3/4 in.	30.....	200	1 3/4 in.

(In cold climates no service less than 3/4 in. should be used.)

**Factors for Reducing Volumes of Gas to Equivalent Volumes at 60° F. and 30-inches Barometer.**

(Multiply the observed volume by the factor to obtain the equivalent volume.)

Temp. Deg. F.	Barometer.										
	30.0	29.8	29.6	29.4	29.2	29.0	28.8	28.6	28.4	28.2	28.0
-30	1.2095	1.2014	1.1934	1.1853	1.1772	1.1692	1.1611	1.1530	1.1450	1.1369	1.1288
-25	1.1956	1.1876	1.1796	1.1716	1.1637	1.1557	1.1476	1.1398	1.1318	1.1238	1.1159
-20	1.1820	1.1741	1.1662	1.1583	1.1505	1.1426	1.1347	1.1268	1.1189	1.1111	1.1032
-15	1.1687	1.1609	1.1531	1.1453	1.1375	1.1297	1.1219	1.1141	1.1064	1.0986	1.0908
-10	1.1557	1.1480	1.1403	1.1326	1.1249	1.1172	1.1095	1.1018	1.0941	1.0863	1.0786
-5	1.1430	1.1354	1.1277	1.1201	1.1125	1.1049	1.0973	1.0896	1.0820	1.0744	1.0668
0	1.1306	1.1230	1.1155	1.1079	1.1004	1.0929	1.0853	1.0778	1.0703	1.0627	1.0552
5	1.1184	1.1109	1.1035	1.0960	1.0885	1.0811	1.0736	1.0662	1.0587	1.0513	1.0438
10	1.1065	1.0991	1.0917	1.0843	1.0770	1.0696	1.0622	1.0548	1.0474	1.0401	1.0327
15	1.0948	1.0875	1.0802	1.0729	1.0656	1.0585	1.0510	1.0437	1.0364	1.0291	1.0218
20	1.0834	1.0762	1.0689	1.0617	1.0545	1.0473	1.0401	1.0328	1.0256	1.0184	1.0112
25	1.0722	1.0651	1.0579	1.0508	1.0436	1.0365	1.0293	1.0222	1.0150	1.0079	1.0007
30	1.0613	1.0542	1.0471	1.0401	1.0330	1.0259	1.0188	1.0118	1.0047	0.9976	0.9905
35	1.0506	1.0435	1.0365	1.0295	1.0225	1.0155	1.0085	1.0015	0.9945	0.9875	0.9805
40	1.0400	1.0331	1.0261	1.0192	1.0123	1.0053	0.9984	0.9915	0.9845	0.9776	0.9707
45	1.0297	1.0229	1.0160	1.0091	1.0023	0.9954	0.9885	0.9817	0.9748	0.9679	0.9611
50	1.0196	1.0128	1.0060	0.9992	0.9924	0.9856	0.9788	0.9720	0.9652	0.9584	0.9516
55	1.0097	1.0030	0.9962	0.9895	0.9828	0.9761	0.9693	0.9626	0.9559	0.9491	0.9424
60	1.0000	0.9933	0.9867	0.9800	0.9733	0.9667	0.9600	0.9533	0.9467	0.9400	0.9333
65	0.9905	0.9838	0.9772	0.9706	0.9640	0.9574	0.9508	0.9442	0.9376	0.9310	0.9244
70	0.9811	0.9746	0.9680	0.9615	0.9550	0.9484	0.9419	0.9353	0.9288	0.9223	0.9157
75	0.9719	0.9655	0.9590	0.9525	0.9460	0.9395	0.9331	0.9266	0.9201	0.9136	0.9071
80	0.9629	0.9565	0.9501	0.9437	0.9373	0.9308	0.9244	0.9180	0.9116	0.9052	0.8987
85	0.9541	0.9477	0.9414	0.9350	0.9286	0.9223	0.9159	0.9096	0.9032	0.8968	0.8905
90	0.9454	0.9391	0.9328	0.9265	0.9202	0.9139	0.9076	0.9013	0.8950	0.8887	0.8824
95	0.9369	0.9306	0.9244	0.9181	0.9119	0.9056	0.8994	0.8931	0.8869	0.8807	0.8744
100	0.9285	0.9223	0.9161	0.9099	0.9037	0.8976	0.8914	0.8852	0.8790	0.8728	0.8666
105	0.9203	0.9141	0.9080	0.9019	0.8957	0.8896	0.8835	0.8773	0.8712	0.8651	0.8589
110	0.9122	0.9061	0.9000	0.8940	0.8879	0.8818	0.8757	0.8696	0.8636	0.8575	0.8514
115	0.9043	0.8982	0.8922	0.8862	0.8801	0.8741	0.8681	0.8621	0.8560	0.8500	0.8440
120	0.8965	0.8905	0.8845	0.8785	0.8726	0.8666	0.8606	0.8546	0.8486	0.8427	0.8367

Formula: Equivalent volume = observed volume  $\times \frac{519.6}{t + 459.6} \times \frac{B}{30}$

**Maximum Supply of Gas through Pipes in cu. ft. per Hour, Specific Gravity being taken at 0.45, calculated from the Formula  $Q = 1000 \sqrt{d^5 h} \div sl.$  (Molesworth.)**

LENGTH OF PIPE = 10 YARDS.

Diameter of Pipe in Inches.	Pressure by the Water-gage in Inches.									
	0.1	0.2	0.3	0.4	0.5	0.6	0.7	0.8	0.9	1.0
1/2	26	37	46	53	59	64	70	74	79	83
3/4	73	103	126	145	162	187	192	205	218	230
1	149	211	258	298	333	365	394	422	447	471
1 1/4	260	368	451	521	582	638	689	737	781	823
1 1/2	411	581	711	821	918	1006	1082	1162	1232	1299
2	843	1192	1460	1686	1886	2066	2231	2385	2530	2667

(Continued on p. 866)



Maximum Supply of Gas through Pipes in cu. ft. per Hour,  
Specific Gravity being taken at 0.45, calculated from the  
Formula  $Q = 1000 \sqrt{d^5 h \div sl}$ . (Molesworth.)—(Continued)

LENGTH OF PIPE = 100 YARDS.

Diam. of Pipe, Inches.	Pressure by the Water-gage in Inches.										
	0.1	0.2	0.3	0.4	0.5	0.75	1.0	1.25	1.5	2	2.5
$\frac{3}{4}$	23	32	42	46	51	63	73	81	89	103	115
1	47	67	82	94	105	129	149	167	183	211	236
$1\frac{1}{4}$	82	116	143	165	184	225	260	291	319	368	412
$1\frac{1}{2}$	130	184	225	260	290	356	411	459	503	581	649
2	267	377	462	533	596	730	843	943	1033	1193	1333
$2\frac{1}{2}$	466	659	807	932	1042	1276	1473	1647	1804	2083	2329
3	735	1039	1270	1470	1643	2012	2323	2593	2846	3286	3674
$3\frac{1}{2}$	1080	1528	1871	2161	2416	2958	3416	3820	4184	4831	5402
4	1508	2133	2613	3017	3373	4131	4770	5333	5842	6746	7542

LENGTH OF PIPE = 1000 YARDS.

Diam. of Pipe, Inches.	Pressure by the Water-gage in Inches.						
	0.5	0.75	1.0	1.5	2.0	2.5	3.0
1	33	41	47	58	67	75	82
$1\frac{1}{2}$	92	113	130	159	184	205	226
2	189	231	267	327	377	422	462
$2\frac{1}{2}$	329	403	466	571	659	737	807
3	520	636	735	900	1039	1162	1273
4	1067	1306	1508	1847	2133	2385	2613
5	1863	2282	2635	3227	3727	4167	4564
6	2939	3600	4157	5091	5879	6573	7200

LENGTH OF PIPE = 5000 YARDS.

Diameter of Pipe in Inches.	Pressure by the Water-gage in Inches.				
	1.0	1.5	2.0	2.5	3.0
2	119	146	169	189	207
3	329	402	465	520	569
4	675	826	955	1067	1168
5	1179	1443	1667	1863	2041
6	1859	2277	2629	2939	3220
7	2733	3347	3865	4321	4734
8	3816	4674	5397	6034	6610
9	5123	6274	7245	8100	8873
10	6667	8165	9428	10541	11547
12	10516	12880	14872	16628	18215

Mr. A. C. Humphreys says his experience goes to show that these tables give too small a flow, but it is difficult to accurately check the tables, on account of the extra friction introduced by rough pipes, bends, etc. For bends, one rule is to allow  $\frac{1}{42}$  of an inch pressure for each right-angle bend.

Where there is apt to be trouble from frost it is well to use no service of less diameter than  $\frac{3}{4}$  in., no matter how short it may be. In extremely cold climates this is now often increased to 1 in., even for a single lamp. The best practice in the U. S. now condemns any service less than  $\frac{3}{4}$  in.

STEAM.

**The Temperature of Steam** in contact with water depends upon the pressure under which it is generated. At the ordinary atmospheric pressure (14.7 lb. per sq. in.) its temperature is 212° F. As the pressure is increased, as by the steam being generated in a closed vessel, its temperature, and that of the water in its presence, increases.

**Saturated Steam** is steam of the temperature due to its pressure—not superheated.

**Superheated Steam** is steam heated to a temperature above that due to its pressure.

**Dry Steam** is steam which contains no moisture. It may be either saturated or superheated.

**Wet Steam** is steam containing intermingled moisture, mist, or spray. It has the same temperature as dry saturated steam of the same pressure.

Water introduced into the presence of superheated steam will flash into steam until the temperature of the steam is reduced to that due its pressure. Water in the presence of saturated steam has the same temperature as the steam. Should cold water be introduced, lowering the temperature of the whole mass, some of the steam will be condensed, reducing the pressure and temperature of the remainder, until equilibrium is established.

**Total Heat of Saturated Steam** (above 32° F.).—According to Marks and Davis, the formula for total heat of steam, based on researches by Henning, Knoblauch, Linde and Klebe, is  $H = 1150.3 + 0.3745(t - 212) - 0.000550(t - 212)^2$ , in which  $H$  is the total heat in B.T.U. above water at 32° F. and  $t$  is the temperature Fahrenheit.

**Latent Heat of Steam.**—The latent heat, or heat of vaporization, is obtained by subtracting from the total heat at any given temperature the heat of the liquid, or total heat above 32° in water of the same temperature.

The total heat in steam (above 32°) includes three elements:

1st. The heat required to raise the temperature of the water to the temperature of the steam.

2d. The heat required to evaporate the water at that temperature, called internal latent heat.

3d. The latent heat of volume, or the external work done by the steam in making room for itself against the pressure of the superincumbent atmosphere (or surrounding steam if inclosed in a vessel).

The sum of the last two elements is called the latent heat of steam.

**Heat required to Generate 1 lb. of Steam from water at 32° F.**

	Heat-units.
Sensible heat, to raise the water from 32° to 212° = . . . . .	180.0
Latent heat, 1, of the formation of steam at 212° = . . . . .	897.6
2, of expansion against the atmospheric pressure, 2116.4 lb. per sq. ft. × 26.79 cu. ft. = 55,786 foot-pounds ÷ 778 = . . . . .	72.8
	970.4
Total heat above 32° F. . . . .	1150.4

**The Heat-Unit, or British Thermal Unit.**—The old definition of the heat-unit (Rankine), viz., the quantity of heat required to raise the temperature of 1 lb. of water 1° F., at or near its temperature of maximum density (39.1° F.), is now (1909) no longer used. Peabody defines it as the heat required to raise a pound of water from 62° to 63° F., and Marks and Davis as  $1/180$  of the heat required to raise 1 lb. of water from 32° to 212° F. By Peabody's definition the heat required to raise 1 lb. of water from 32° to 212° is 180.3 instead of 180 units, and the heat of vaporization at 212° is 969.7 instead of 970.4 units.

**Specific Heat of Saturated Steam.**—When a unit weight of saturated steam is increased in temperature and in pressure, the volume decreasing so as to just keep it saturated, the specific heat is negative, and decreases as temperature increases. (See Wood, Thermodynamics, p. 147; Peabody, Thermodynamics, p. 93.)

**Absolute Zero.**—The value of the absolute zero has been variously given as from 459.2 to 460.66 degrees below the Fahrenheit zero. Marks and Davis, comparing the results of Berthelot (1903), Buckingham, 1907, and Ross-Innes, 1908, give as the most probable value—459.64° F. The value—460° is close enough for all engineering calculations.

**The Mechanical Equivalent of Heat.**—The value generally accepted, based on Rowland's experiments, is 778 ft.-lb. Marks and Davis give the value 777.52 standard ft.-lb., based on later experiments, and on the value of  $g = 980.665$  cm. per sec.<sup>2</sup>, = 32.174 ft. per sec.<sup>2</sup>, fixed by international agreement (1901). [With this value of  $g$  and the mean gram-calorie being taken as equivalent to  $4.1834 \times 10^7$  dyne-centimeters, the equivalent of 1 B.T.U. is 777.54 ft.-lb.] These values of the absolute zero and of the mechanical equivalent of heat have been used by Marks and Davis in the computation of their steam tables. In refined investigations involving the value of the mechanical equivalent of heat the value of  $g$  for the latitude in which the experiments are made must be considered.

Marks and Davis give the value of the mean gram-calorie as 4.1834 joules, which is equivalent to 777.54 ft.-lb. = 1 B.T.U. Goodenough, taking 1 mean calorie = 4.184 joules, gives 1 mean B.T.U. = 777.64 ft.-lb.

**Pressure of Saturated Steam.**—Holborn and Henning, *Zeit. des Ver. deutscher Ingenieure*, Feb. 20, 1909, report results of measurements of the pressures of saturated steam at temperatures ranging from 50° to 200° C. (112° to 392° F.). Their values agree closely with those obtained in 1905 by Knoblauch, Linde and Klebe. From a table in the article giving pressures for each degree from 0° to 200° C., the following values have been transformed into English measurements (*Eng. Digest*, April, 1909).

Deg. F.	Lb. per sq. in.	Deg. F.	Lb. per sq. in.	Deg. F.	Lb. per sq. in.
32	0.0885	150	3.715	300	66.972
68	0.3386	200	11.527	350	134.508
100	0.9462	250	29.819	400	248.856

**Volume of Saturated Steam.**—The values of specific volumes of saturated steam are computed by Clapeyron's equation (Marks and Davis's Tables), which gives results remarkably close to those found in the experiments of Knoblauch, Linde and Klebe.

**Goodenough's Steam Tables.** (Properties of Steam and Ammonia, John Wiley & Sons, 1915.)—These tables are based on the same original data as those of Marks and Davis, and on some later ones. They adopt the same definition of the thermal unit, the mean B.T.U. or  $1/180$  of the heat required to raise the temperature of 1 lb. of water from 32° to 212° F. The differences between the figures given in the two sets of tables are in general small; the most important being that the latent heat of steam at 212° F. is given as 971.7 B.T.U. instead of 970.4, the figure given by Marks and Davis. A comparison of some figures from the two tables is given on p. 869, Goodenough's values being given in the upper lines (G), and Marks and Davis's in the lower lines (M), only the digits which differ from those in the upper lines being given.

**Properties of Saturated Steam at High Temperatures.**—(From G. A. Goodenough's Properties of Steam and Ammonia, 1915.)

Temp. ° F.	Pressure Lb. per Sq. in.	Volume of 1 Lb., Cu. ft.	Weight of 1 Cu. ft., Lb.	Heat of Liquid B.T.U.	Heat of Vapor, B.T.U.	Latent Heat, B.T.U.
600	1540	0.272	3.68	604.5	1164.2	488.9
620	1784	0.226	4.43	633	1151	452
640	2057	0.186	5.38	664	1134	409
660	2361	0.151	6.60	700	1112	358
680	2699	0.118	8.5	745	1080	290
700	3075	0.080	12.5	820	1018	171
706.3	3200	0.048	20.90	921	921	0



**Properties of Saturated Steam.**

Comparison of Goodenough and Marks and Davis (see p. 868.)

	Absolute Pressure.	Temperature ° F.	Total Heat Above 32°.		Latent Heat.	Volume, Cu. Ft. in 1 Lb.	Weight of 1 Cu.Ft.	Entropy.	
			In Water.	In Steam.				Water.	Vaporization.
G.	0.0887	32	0	1073.0	1073.0	3296	0.000304	0	2.1826
M.	"	"	"	.4	.4	4	"	"	32
G.	0.949	100	68.00	1104.6	1036.6	350.3	0.002855	0.1296	1.8523
M.	"	"	7.97	3.6	5.6	.8	1	5	05
G.	14.7	212	180	1151.7	971.7	26.81	0.03730	0.3120	1.4469
M.	"	"	"	0.4	0.4	.79	2	18	47
G.	50	281	249.8	1175.6	925.9	8.53	0.1173	0.4108	1.2501
M.	"	"	50.1	3.6	3.5	1	5	13	468
G.	100	327.8	297.9	1188.4	890.5	4.442	0.2251	0.4736	1.1309
M.	"	"	8.3	6.3	88.0	29	8	43	277
G.	150	358.5	329.8	1194.7	864.9	3.020	0.3311	0.5131	1.0573
M.	"	"	30.2	3.4	3.2	12	20	42	50
G.	200	381.9	354.5	1198.5	844.0	2.292	0.4364	0.5426	1.0030
M.	"	"	.9	.1	3.2	0	70	37	19
G.	250	401.1	374.9	1200.6	825.8	1.846	0.542	0.5663	0.9595
M.	"	"	5.2	1.5	6.3	50	1	76	600
G.	300	417.5	392.4	1201.9	809.4	1.545	0.647	0.5863	0.9229
M.	"	"	.7	4.1	11.3	51	5	78	51
G.	400	444.8	422.0	1202.5	780.6	1.162	0.860	0.6190	0.8631
M.	"	"	"	8.	6.	70	"	210	80
G.	500	467.2	446.6	1201.7	755.0	0.928	1.077	0.6455	0.8146
M.	"	.3	8.	10.	62.	30	80	80	220
G.	600	486.5	468.0	1199.8	731.8	0.770	1.30	0.6679	0.7735
M.	"	.6	9.	210.	41.	60	2	700	830

**Volume of Superheated Steam.**—Linde's equation (1905),

$$pv = 0.5962 T - p (1 + 0.0014 p) \left( \frac{150,300,000}{T^3} - 0.0833 \right),$$

in which *p* is in lb. per sq. in., *v* is in cu. ft. and *T* is the absolute temperature on the Fahrenheit scale, has been used in the computation of Marks and Davis's tables.

**Specific Heat of Superheated Steam.**—Mean specific heats from the temperature of saturation to various temperatures at several pressures English and metric units.—Knoblauch and Jakob (from Peabody's Tables).

Kg. per sq. cm.	1	2	4	6	8	10	12	14	16	18	20
Lb. per sq. in.	14.2	28.4	56.9	85.3	113.3	142.2	170.6	199.1	227.5	256.0	284.4
Temp., sat. °C.	99	120	143	158	169	179	187	194	200	206	211
Temp., sat. °F.	210	248	289	316	336	350	368	381	392	403	412
° F.	° C.										
212	100	0.463									
302	150	.462	0.478	0.515							
392	200	.462	.475	.502	0.530	0.560	0.597	0.635	0.677		
482	250	.463	.474	.495	.514	.532	.552	.570	.588	0.609	0.635
572	300	.464	.475	.492	.505	.517	.530	.541	.550	.561	.572
662	350	.468	.477	.492	.503	.512	.522	.529	.536	.543	.550
752	400	.473	.481	.494	.504	.512	.520	.526	.531	.537	.542

**Properties of Superheated Steam.**—See the table on page 871, condensed from Marks and Davis's tables.

**The Specific Density of Gaseous Steam,** that is, steam considerably superheated, is 0.622, that of air being 1. That is to say, the weight of a cubic foot of gaseous steam is about five-eighths of that of a cubic foot of air, of the same pressure and temperature.

The density or weight of a cubic foot of gaseous steam is expressible by the same formula as that of air, except that the multiplier or coefficient is less in proportion to the less specific density. Thus,

$$D = \frac{2.7074 p \times 0.622}{t + 460} = \frac{1.684 p}{t + 460},$$

in which  $D$  is the weight of a cubic foot,  $p$  the total pressure per square inch and  $t$  the temperature Fahrenheit. (Clark's Steam-engine.)

H. M. Prevost Murphy (*Eng. News*, June 18, 1908) shows that the specific density is not a constant, but varies with the temperature, and that the correct value is  $0.6113 + \frac{0.092t}{850 - t}$ .

**The Rationalization of Regnault's Experiments on Steam.**—(J. McFarlane Gray, *Proc. Inst. M. E.*, July, 1889.)—The formulæ constructed by Regnault are strictly empirical, and were based entirely on his experiments. They are therefore not valid beyond the range of temperatures and pressures observed.

Mr. Gray has made a most elaborate calculation, based not on experiments but on fundamental principles of thermodynamics, from which he deduces formulæ for the pressure and total heat of steam, and presents tables calculated therefrom which show substantial agreement with Regnault's figures. He gives the following examples of steam-pressures calculated for temperatures beyond the range of Regnault's experiments.

Temperature.		Pounds per Sq. In.	Temperature.		Pounds per Sq. In.
C.	Fahr.		C.	Fahr.	
230	446	406.9	340	644	2156.2
240	464	488.9	360	680	2742.5
250	482	579.9	380	716	3448.1
260	500	691.6	400	752	4300.2
280	536	940.0	415	779	5017.1
300	572	1261.8	427	800.6	5659.9
320	608	1661.9			

These pressures are higher than those obtained by Regnault's formula, which gives for 415° C. only 4067.1 lbs. per square inch.

**Available Energy in Expanding Steam.**—Rankine Cycle. (J. B. Stanwood, *Power*, June 9, 1908.)—A simple formula for finding, with the aid of the steam and entropy tables, the available energy per pound of steam in B.T.U. when it is expanded adiabatically from a higher to a lower pressure is:

$$U = H - H_1 + T(N_1 - N).$$

$U$  = available B.T.U. in 1 lb. of expanding steam;  $H$  and  $H_1$  total heat in 1 lb. steam at the two pressures;  $T$  = absolute temperature at the lower pressure;  $N - N_1$ , difference of entropy of 1 lb. of steam at the two pressures.

**EXAMPLE.**—Required the available B.T.U. in 1 lb. steam expanded from 100 lbs. to 14.7 lbs. absolute.  $H = 1186.3$ ;  $H_1 = 1150.4$ ;  $T = 672$ ;  $N = 1.602$ ;  $N_1 = 1.756$ .  $35.9 + 103.5 = 138.4$ .

**Efficiency of the Cycle.**—Let the steam be made from feed-water at 212°. Heat required =  $1186.3 - 180 = 1006.3$ ; efficiency =  $138.4 \div 1006.3 = 0.1375$ .

**Rankine Cycle.**—This efficiency is that of the Rankine cycle, which assumes that the steam is expanded adiabatically to the exhaust pressure and temperature, and that the feed-water from which the steam is made is introduced into the system at the temperature of the exhaust.

**Carnot Cycle.**—The Carnot ideal cycle, which assumes that all the heat entering the system enters at the highest temperature, and in which the efficiency is  $(T_1 - T_2) \div T_1$ , gives  $(327.8 - 212) \div (327.8 + 460) = 0.1470$  and the available energy in B.T.U. =  $0.1470 \times 1006.3 = 147.9$  B.T.U.

### Properties of Saturated Steam.

(Condensed from Marks and Davis's Steam Tables and Diagrams, 1909,  
by permission of the publishers, Longmans, Green & Co.)

Vacuum, Inches of Mercury.	Absolute Pressure, Lbs. per Sq. In.	Temperature, Fahrenheit.	Total Heat above 32° F.		Latent Heat, $L$ $= H - h$ Units.	Volume, Cu. Ft. in 1 Lb. of Steam.	Weight of 1 Cu. Ft. Steam, Lb.	Entropy of the Water.	Entropy of Evap- oration.
			in the Water $h$ Heat-Units.	in the Steam $H$ Heat-Units.					
29.74	0.0886	32	0.00	1073.4	1073.4	3294	0.000304	0.0000	2.1832
29.67	0.1217	40	8.05	1076.9	1068.9	2438	0.000410	0.0162	2.1394
29.56	0.1780	50	18.08	1081.4	1063.3	1702	0.000587	0.0361	2.0865
29.40	0.2562	60	28.08	1085.9	1057.8	1208	0.000828	0.0555	2.0358
29.18	0.3626	70	38.06	1090.3	1052.3	871	0.001148	0.0745	1.9868
28.89	0.505	80	48.03	1094.8	1046.7	636.8	0.001570	0.0932	1.9398
28.50	0.696	90	58.00	1099.2	1041.2	469.3	0.002131	0.1114	1.8944
28.00	0.946	100	67.97	1103.6	1035.6	350.8	0.002851	0.1295	1.8505
27.88	1	101.83	69.8	1104.4	1034.6	333.0	0.003000	0.1327	1.8427
25.85	2	126.15	94.0	1115.0	1021.0	173.5	0.00576	0.1749	1.7431
23.81	3	141.52	109.4	1121.6	1012.3	118.5	0.00845	0.2008	1.6840
21.78	4	153.01	120.9	1126.5	1005.7	90.5	0.01107	0.2198	1.6416
19.74	5	162.28	130.1	1130.5	1000.3	73.33	0.01364	0.2348	1.6084
17.70	6	170.06	137.9	1133.7	995.8	61.89	0.01616	0.2471	1.5814
15.67	7	176.85	144.7	1136.5	991.8	53.56	0.01867	0.2579	1.5582
13.63	8	182.86	150.8	1139.0	988.2	47.27	0.02115	0.2673	1.5380
11.60	9	188.27	156.2	1141.1	985.0	42.36	0.02361	0.2756	1.5202
9.56	10	193.22	161.1	1143.1	982.0	38.38	0.02606	0.2832	1.5042
7.52	11	197.75	165.7	1144.9	979.2	35.10	0.02849	0.2902	1.4895
5.49	12	201.96	169.9	1146.5	976.6	32.36	0.03090	0.2967	1.4760
3.45	13	205.87	173.8	1148.0	974.2	30.03	0.03330	0.3025	1.4639
1.42	14	209.55	177.5	1149.4	971.9	28.02	0.03569	0.3081	1.4523
lbs. gage.	14.70	212	180.0	1150.4	970.4	26.79	0.03732	0.3118	1.4447
0.3	15	213.0	181.0	1150.7	969.7	26.27	0.03806	0.3133	1.4416
1.3	16	216.3	184.4	1152.0	967.6	24.79	0.04042	0.3183	1.4311
2.3	17	219.4	187.5	1153.1	965.6	23.38	0.04277	0.3229	1.4215
3.3	18	222.4	190.5	1154.2	963.7	22.16	0.04512	0.3273	1.4127
4.3	19	225.2	193.4	1155.2	961.8	21.07	0.04746	0.3315	1.4045
5.3	20	228.0	196.1	1156.2	960.0	20.08	0.04980	0.3355	1.3965
6.3	21	230.6	198.8	1157.1	958.3	19.18	0.05213	0.3393	1.3887
7.3	22	233.1	201.3	1158.0	956.7	18.37	0.05445	0.3430	1.3811
8.3	23	235.5	203.8	1158.8	955.1	17.62	0.05676	0.3465	1.3739
9.3	24	237.8	206.1	1159.6	953.5	16.93	0.05907	0.3499	1.3670
10.3	25	240.1	208.4	1160.4	952.0	16.30	0.0614	0.3532	1.3604
11.3	26	242.2	210.6	1161.2	950.6	15.72	0.0636	0.3564	1.3542
12.3	27	244.4	212.7	1161.9	949.2	15.18	0.0659	0.3594	1.3483
13.3	28	246.4	214.8	1162.6	947.8	14.67	0.0682	0.3623	1.3425
14.3	29	248.4	216.8	1163.2	946.4	14.19	0.0705	0.3652	1.3367
15.3	30	250.3	218.8	1163.9	945.1	13.74	0.0728	0.3680	1.3311
16.3	31	252.2	220.7	1164.5	943.8	13.32	0.0751	0.3707	1.3257
17.3	32	254.1	222.6	1165.1	942.5	12.93	0.0773	0.3733	1.3205
18.3	33	255.8	224.4	1165.7	941.3	12.57	0.0795	0.3759	1.3155
19.3	34	257.6	226.2	1166.3	940.1	12.22	0.0818	0.3784	1.3107
20.3	35	259.3	227.9	1166.8	938.9	11.89	0.0841	0.3808	1.3060
21.3	36	261.0	229.6	1167.3	937.7	11.58	0.0863	0.3832	1.3014
22.3	37	262.6	231.3	1167.8	936.6	11.29	0.0886	0.3855	1.2969
23.3	38	264.2	232.9	1168.4	935.5	11.01	0.0908	0.3877	1.2925
24.3	39	265.8	234.5	1168.9	934.4	10.74	0.0931	0.3899	1.2882
25.3	40	267.3	236.1	1169.4	933.3	10.49	0.0953	0.3920	1.2841
26.3	41	268.7	237.6	1169.8	932.2	10.25	0.0976	0.3941	1.2800
27.3	42	270.2	239.1	1170.3	931.2	10.02	0.0998	0.3962	1.2759
28.3	43	271.7	240.5	1170.7	930.2	9.80	0.1020	0.3982	1.2720
29.3	44	273.1	242.0	1171.2	929.2	9.59	0.1043	0.4002	1.2681
30.3	45	274.5	243.4	1171.6	928.2	9.39	0.1065	0.4021	1.2644



## Properties of Saturated Steam. (Continued.)

Gauge Pressure, Lbs. per Sq. In.	Absolute Pressure, Lbs. per Sq. In.	Temperature, Fahrenheit.	Total Heat above 32° F.		Latent Heat, $L$ $= H - h$ Heat- Units.	Volume, Cu. Ft. in 1 Lb. of Steam.	Weight of 1 Cu. Ft. Steam, Lb.	Entropy of the Water.	Entropy of Evap- oration.
			In the Water $h$ Heat-Units.	In the Steam $H$ Heat-Units.					
31.3	46	275.8	244.8	1172.0	927.2	9.20	0.1087	0.4040	1.2607
32.3	47	277.2	246.1	1172.4	926.3	9.02	0.1109	0.4059	1.2571
33.3	48	278.5	247.5	1172.8	925.3	8.84	0.1131	0.4077	1.2536
34.3	49	279.8	248.8	1173.2	924.4	8.67	0.1153	0.4095	1.2502
35.3	50	281.0	250.1	1173.6	923.5	8.51	0.1175	0.4113	1.2468
36.3	51	282.3	251.4	1174.0	922.6	8.35	0.1197	0.4130	1.2432
37.3	52	283.5	252.6	1174.3	921.7	8.20	0.1219	0.4147	1.2405
38.3	53	284.7	253.9	1174.7	920.8	8.05	0.1241	0.4164	1.2370
39.3	54	285.9	255.1	1175.0	919.9	7.91	0.1263	0.4180	1.2339
40.3	55	287.1	256.3	1175.4	919.0	7.78	0.1285	0.4196	1.2309
41.3	56	288.2	257.5	1175.7	918.2	7.65	0.1307	0.4212	1.2278
42.3	57	289.4	258.7	1176.0	917.4	7.52	0.1329	0.4227	1.2248
43.3	58	290.5	259.8	1176.4	916.5	7.40	0.1350	0.4242	1.2218
44.3	59	291.6	261.0	1176.7	915.7	7.28	0.1372	0.4257	1.2189
45.3	60	292.7	262.1	1177.0	914.9	7.17	0.1394	0.4272	1.2160
46.3	61	293.8	263.2	1177.3	914.1	7.06	0.1416	0.4287	1.2132
47.3	62	294.9	264.3	1177.6	913.3	6.95	0.1438	0.4302	1.2104
48.3	63	295.9	265.4	1177.9	912.5	6.85	0.1460	0.4316	1.2077
49.3	64	297.0	266.4	1178.2	911.8	6.75	0.1482	0.4330	1.2050
50.3	65	298.0	267.5	1178.5	911.0	6.65	0.1503	0.4344	1.2024
51.3	66	299.0	268.5	1178.8	910.2	6.56	0.1525	0.4358	1.1998
52.3	67	300.0	269.6	1179.0	909.5	6.47	0.1547	0.4371	1.1972
53.3	68	301.0	270.6	1179.3	908.7	6.38	0.1569	0.4385	1.1946
54.3	69	302.0	271.6	1179.6	908.0	6.29	0.1590	0.4398	1.1921
55.3	70	302.9	272.6	1179.8	907.2	6.20	0.1612	0.4411	1.1896
56.3	71	303.9	273.6	1180.1	906.5	6.12	0.1634	0.4424	1.1872
57.3	72	304.8	274.5	1180.4	905.8	6.04	0.1656	0.4437	1.1848
58.3	73	305.8	275.5	1180.6	905.1	5.96	0.1678	0.4449	1.1825
59.3	74	306.7	276.5	1180.9	904.4	5.89	0.1699	0.4462	1.1801
60.3	75	307.6	277.4	1181.1	903.7	5.81	0.1721	0.4474	1.1778
61.3	76	308.5	278.3	1181.4	903.0	5.74	0.1743	0.4487	1.1755
62.3	77	309.4	279.3	1181.6	902.3	5.67	0.1764	0.4499	1.1730
63.3	78	310.3	280.2	1181.8	901.7	5.60	0.1786	0.4511	1.1712
64.3	79	311.2	281.1	1182.1	901.0	5.54	0.1808	0.4523	1.1687
65.3	80	312.0	282.0	1182.3	900.3	5.47	0.1829	0.4535	1.1665
66.3	81	312.9	282.9	1182.5	899.7	5.41	0.1851	0.4546	1.1644
67.3	82	313.8	283.8	1182.8	899.0	5.34	0.1873	0.4557	1.1623
68.3	83	314.6	284.6	1183.0	898.4	5.28	0.1894	0.4568	1.1602
69.3	84	315.4	285.5	1183.2	897.7	5.22	0.1915	0.4579	1.1581
70.3	85	316.3	286.3	1183.4	897.1	5.16	0.1937	0.4590	1.1561
71.3	86	317.1	287.2	1183.6	896.4	5.10	0.1959	0.4601	1.1540
72.3	87	317.9	288.0	1183.8	895.8	5.05	0.1980	0.4612	1.1520
73.3	88	318.7	288.9	1184.0	895.2	5.00	0.2001	0.4623	1.1500
74.3	89	319.5	289.7	1184.2	894.6	4.94	0.2023	0.4633	1.1481
75.3	90	320.3	290.5	1184.4	893.9	4.89	0.2044	0.4644	1.1461
76.3	91	321.1	291.3	1184.6	893.3	4.84	0.2065	0.4654	1.1442
77.3	92	321.8	292.1	1184.8	892.7	4.79	0.2087	0.4664	1.1423
78.3	93	322.6	292.9	1185.0	892.1	4.74	0.2109	0.4674	1.1404
79.3	94	323.4	293.7	1185.2	891.5	4.69	0.2130	0.4684	1.1385
80.3	95	324.1	294.5	1185.4	890.9	4.65	0.2151	0.4694	1.1367
81.3	96	324.9	295.3	1185.6	890.3	4.60	0.2172	0.4704	1.1348
82.3	97	325.6	296.1	1185.8	889.7	4.56	0.2193	0.4714	1.1330
83.3	98	326.4	296.8	1186.0	889.2	4.51	0.2215	0.4724	1.1312
84.3	99	327.1	297.6	1186.2	888.6	4.47	0.2237	0.4733	1.1295
85.3	100	327.8	298.3	1186.3	888.0	4.429	0.2258	0.4743	1.1277
87.3	102	329.3	299.8	1186.7	886.9	4.347	0.2300	0.4762	1.1242
89.3	104	330.7	301.3	1187.0	885.8	4.268	0.2343	0.4780	1.1208

## Properties of Saturated Steam. (Continued.)

Gauge Pressure, Lbs. per Sq. In.	Absolute Pressure, Lbs. per Sq. In.	Temperature, Fahrenheit.	Total Heat above 32° F.		Latent Heat, $L$ $= H - h$ Units.	Volume, Cu. Ft. in 1 Lb. of Steam.	Weight of 1 Cu. Ft. Steam, Lb.	Entropy of the Water.	Entropy of Evap- oration.
			In the Water $h$ Heat-Units.	In the Steam $H$ Heat-Units.					
91.3	106	332.0	302.7	1187.4	884.7	4.192	0.2336	0.4798	1.1174
93.3	108	333.4	304.1	1187.7	883.6	4.118	0.2429	0.4816	1.1141
95.3	110	334.8	305.5	1188.0	882.5	4.047	0.2472	0.4834	1.1108
97.3	112	336.1	306.9	1188.4	881.4	3.978	0.2514	0.4852	1.1076
99.3	114	337.4	308.3	1188.7	880.4	3.912	0.2556	0.4869	1.1045
101.3	116	338.7	309.6	1189.0	879.3	3.848	0.2599	0.4886	1.1014
103.3	118	340.0	311.0	1189.3	878.3	3.786	0.2641	0.4903	1.0984
105.3	120	341.3	312.3	1189.6	877.2	3.726	0.2683	0.4919	1.0954
107.3	122	342.5	313.6	1189.8	876.2	3.668	0.2726	0.4935	1.0924
109.3	124	343.8	314.9	1190.1	875.2	3.611	0.2769	0.4951	1.0895
111.3	126	345.0	316.2	1190.4	874.2	3.556	0.2812	0.4967	1.0865
113.3	128	346.2	317.4	1190.7	873.3	3.504	0.2854	0.4982	1.0837
115.3	130	347.4	318.6	1191.0	872.3	3.452	0.2897	0.4998	1.0809
117.3	132	348.5	319.9	1191.2	871.3	3.402	0.2939	0.5013	1.0782
119.3	134	349.7	321.1	1191.5	870.4	3.354	0.2981	0.5028	1.0755
121.3	136	350.8	322.3	1191.7	869.4	3.308	0.3023	0.5043	1.0728
123.3	138	352.0	323.4	1192.0	868.5	3.263	0.3065	0.5057	1.0702
125.3	140	353.1	324.6	1192.2	867.6	3.219	0.3107	0.5072	1.0675
127.3	142	354.2	325.8	1192.5	866.7	3.175	0.3150	0.5086	1.0649
129.3	144	355.3	326.9	1192.7	865.8	3.133	0.3192	0.5100	1.0624
131.3	146	356.3	328.0	1192.9	864.9	3.092	0.3234	0.5114	1.0599
133.3	148	357.4	329.1	1193.2	864.0	3.052	0.3276	0.5128	1.0574
135.3	150	358.5	330.2	1193.4	863.2	3.012	0.3320	0.5142	1.0550
137.3	152	359.5	331.4	1193.6	862.3	2.974	0.3362	0.5155	1.0525
139.3	154	360.5	332.4	1193.8	861.4	2.938	0.3404	0.5169	1.0501
141.3	156	361.6	333.5	1194.1	860.6	2.902	0.3446	0.5182	1.0477
143.3	158	362.6	334.6	1194.3	859.7	2.868	0.3488	0.5195	1.0454
145.3	160	363.6	335.6	1194.5	858.8	2.834	0.3529	0.5208	1.0431
147.3	162	364.6	336.7	1194.7	858.0	2.801	0.3570	0.5220	1.0409
149.3	164	365.6	337.7	1194.9	857.2	2.769	0.3612	0.5233	1.0387
151.3	166	366.5	338.7	1195.1	856.4	2.737	0.3654	0.5245	1.0365
153.3	168	367.5	339.7	1195.3	855.5	2.706	0.3696	0.5257	1.0343
155.3	170	368.5	340.7	1195.4	854.7	2.675	0.3738	0.5269	1.0321
157.3	172	369.4	341.7	1195.6	853.9	2.645	0.3780	0.5281	1.0300
159.3	174	370.4	342.7	1195.8	853.1	2.616	0.3822	0.5293	1.0278
161.3	176	371.3	343.7	1196.0	852.3	2.588	0.3864	0.5305	1.0257
163.3	178	372.2	344.7	1196.2	851.5	2.560	0.3906	0.5317	1.0235
165.3	180	373.1	345.6	1196.4	850.8	2.533	0.3948	0.5328	1.0215
167.3	182	374.0	346.6	1196.6	850.0	2.507	0.3989	0.5339	1.0195
169.3	184	374.9	347.6	1196.8	849.2	2.481	0.4031	0.5351	1.0174
171.3	186	375.8	348.5	1196.9	848.4	2.455	0.4073	0.5362	1.0154
173.3	188	376.7	349.4	1197.1	847.7	2.430	0.4115	0.5373	1.0134
175.3	190	377.6	350.4	1197.3	846.9	2.406	0.4157	0.5384	1.0114
177.3	192	378.5	351.3	1197.4	846.1	2.381	0.4199	0.5395	1.0095
179.3	194	379.3	352.2	1197.6	845.4	2.358	0.4241	0.5405	1.0076
181.3	196	380.2	353.1	1197.8	844.7	2.335	0.4283	0.5416	1.0056
183.3	198	381.0	354.0	1197.9	843.9	2.312	0.4325	0.5426	1.0038
185.3	200	381.9	354.9	1198.1	843.2	2.290	0.437	0.5437	1.0019
190.3	205	384.0	357.1	1198.5	841.4	2.237	0.447	0.5463	0.9973
195.3	210	386.0	359.2	1198.8	839.6	2.187	0.457	0.5488	0.9928
200.3	215	388.0	361.4	1199.2	837.9	2.138	0.468	0.5513	0.9885
205.3	220	389.9	363.4	1199.6	836.2	2.091	0.478	0.5538	0.9841
210.3	225	391.9	365.5	1199.9	834.4	2.046	0.489	0.5562	0.9799
215.3	230	393.8	367.5	1200.2	832.8	2.004	0.499	0.5586	0.9758
220.3	235	395.6	369.4	1200.6	831.1	1.964	0.509	0.5610	0.9717
225.3	240	397.4	371.4	1200.9	829.5	1.924	0.520	0.5633	0.9676
230.3	245	399.3	373.3	1201.2	827.9	1.887	0.530	0.5655	0.9638

## Properties of Saturated Steam. (Continued.)

Gauge Pressure, Lbs. per Sq. In.	Absolute Pressure, Lbs. per Sq. In.	Temperature, Fahrenheit.	Total Heat above 32° F.		Latent Heat, $L$ $= H - h$ Units.	Volume, Cu. Ft. in 1 Lb. of Steam.	Weight of 1 Cu. Ft. Steam, Lb.	Entropy of the Water.	Entropy of Evap- oration.
			In the Water $h$ Heat-Units.	In the Steam $H$ Heat-Units.					
235.3	250	401.1	375.2	1201.5	826.3	1.850	0.541	0.5676	0.9600
245.3	260	404.5	378.9	1202.1	823.1	1.782	0.561	0.5719	0.9525
255.3	270	407.9	382.5	1202.6	820.1	1.718	0.582	0.5760	0.9454
265.3	280	411.2	386.0	1203.1	817.1	1.658	0.603	0.5800	0.9385
275.3	290	414.4	389.4	1203.6	814.2	1.602	0.624	0.5840	0.9316
285.3	300	417.5	392.7	1204.1	811.3	1.551	0.645	0.5878	0.9251
295.3	310	420.5	395.9	1204.5	808.5	1.502	0.666	0.5915	0.9187
305.3	320	423.4	399.1	1204.9	805.8	1.456	0.687	0.5951	0.9125
315.3	330	426.3	402.2	1205.3	803.1	1.413	0.708	0.5986	0.9065
325.3	340	429.1	405.3	1205.7	800.4	1.372	0.729	0.6020	0.9006
335.3	350	431.9	408.2	1206.1	797.8	1.334	0.750	0.6053	0.8949
345.3	360	434.6	411.2	1206.4	795.3	1.298	0.770	0.6085	0.8894
355.3	370	437.2	414.0	1206.8	792.8	1.264	0.791	0.6116	0.8840
365.3	380	439.8	416.8	1207.1	790.3	1.231	0.812	0.6147	0.8788
375.3	390	442.3	419.5	1207.4	787.9	1.200	0.833	0.6178	0.8737
385.3	400	444.8	422	1208	786	1.17	0.86	0.621	0.868
435.3	450	456.5	435	1209	774	1.04	0.96	0.635	0.844
485.3	500	467.3	448	1210	762	0.93	1.08	0.648	0.822
535.3	550	477.3	459	1210	751	0.83	1.20	0.659	0.801
585.3	600	486.6	469	1210	741	0.76	1.32	0.670	0.783

## Properties of Superheated Steam, Marks &amp; Davis and Goodenough Compared.

$v$  = volume, cu. ft. per lb.;  $h$  = total heat above 32° F.;  $n$  = entropy.

The figures in the upper lines are from Marks and Davis's tables, those in the lower lines (the differing digits only being given) are interpolated from Goodenough's tables, in which the figures are for steam of given temperatures, not even degrees of superheat.

Absolute Pressure.	Temp. Sat. Steam.	Superheat, Degrees Fahrenheit.								
		50	100	150	200	250	300	400	500	
20	228.0	$v$	21.69	23.25	24.80	26.33	27.85	29.37	32.39	35.40
			8	3	.77	.29	1	1	1	30
		$h$	1179.9	1203.5	1227.1	1250.6	1274.1	1297.6	1344.8	1392.2
			7.3	6.0	9.8	3.5	7.0	300.7	8.5	7.0
		$n$	1.7652	1.7961	1.8251	1.8524	1.8781	1.9026	1.9479	1.9893
			86	8000	92	64	823	69	530	956
100	327.8	$v$	4.79	5.14	5.47	5.80	6.12	6.44	7.07	7.69
			"	3	6	.79	0	1	3	4
		$h$	1213.8	1239.7	1264.7	1289.4	1313.6	1337.8	1385.9	1434.1
			5.9	42.5	8.3	93.6	8.7	43.7	93.6	43.9
		$n$	1.6358	1.6658	1.6933	1.7188	1.7428	1.7656	1.8079	1.8468
			84	91	74	235	84	720	159	566
200	381.9	$v$	2.49	2.68	2.86	3.04	3.21	3.38	3.71	.....
			.50	9	5	2	.18	4	.66	.....
		$h$	1229.8	1257.1	1282.6	1307.7	1332.4	1357.0	1405.9	.....
			1	8.0	5.7	12.7	9.0	65.1	16.8	.....
		$n$	1.5823	1.6120	1.6385	1.6632	1.6862	1.7082	1.7493	.....
			09	5	411	76	922	156	596	.....
300	417.5	$v$	1.69	1.83	1.96	2.09	2.21	2.33	2.55	.....
			"	2	4	6	.18	.29	0	.....
		$h$	1240.3	1268.2	1294.0	1319.3	1344.3	1369.2	1418.6	.....
			35.0	5.9	5.2	23.3	51.0	78.1	31.5	.....
		$n$	1.5530	1.5824	1.6082	1.6323	1.6550	1.6765	1.7168	.....
			458	784	76	44	94	829	265	.....



Properties of Superheated Steam.

(Condensed from Marks and Davis's Steam Tables and Diagrams.)

$v$  = specific volume in cu. ft. per lb.,  $h$  = total heat, from water at 32° F. in B.T.U. per lb.,  $n$  = entropy, from water at 32°.

Press. Abs. Lbs. per Sq. In.	Temp. Sat. Steam.	Degrees of Superheat.									
		0	20	50	100	150	200	250	300	400	500
20	228.0	v 20.08	20.73	21.69	23.25	24.80	26.33	27.85	29.37	32.39	35.40
		h 1156.2	1165.7	1179.9	1203.5	1227.1	1250.6	1274.1	1297.6	1344.8	1392.2
40	267.3	n 1.7320	1.7456	1.7652	1.7961	1.8251	1.8524	1.8781	1.9026	1.9479	1.9893
		v 10.49	10.83	11.33	12.13	12.93	13.70	14.48	15.25	16.78	18.30
60	292.7	h 1169.4	1179.3	1194.0	1218.4	1242.4	1266.4	1290.3	1314.1	1361.6	1409.3
		n 1.6761	1.6895	1.7089	1.7392	1.7674	1.7940	1.8189	1.8427	1.8867	1.9271
80	312.0	v 7.17	7.40	7.75	8.30	8.84	9.36	9.89	10.41	11.43	12.45
		h 1177.0	1187.3	1202.6	1227.6	1252.1	1276.4	1300.4	1324.3	1372.2	1420.0
100	327.8	n 1.6432	1.6568	1.6761	1.7062	1.7342	1.7603	1.7849	1.8081	1.8511	1.8908
		v 5.47	5.65	5.92	6.34	6.75	7.17	7.56	7.95	8.72	9.49
120	341.3	h 1182.3	1193.0	1208.8	1234.3	1259.0	1283.6	1307.8	1331.9	1379.8	1427.9
		n 1.6200	1.6338	1.6532	1.6833	1.7110	1.7368	1.7612	1.7840	1.8265	1.8658
140	353.1	v 4.43	4.58	4.79	5.14	5.47	5.80	6.12	6.44	7.07	7.69
		h 1186.3	1197.5	1213.8	1239.7	1264.7	1289.4	1313.6	1337.8	1385.9	1434.1
160	363.6	n 1.6020	1.6160	1.6358	1.6658	1.6933	1.7188	1.7428	1.7656	1.8079	1.8468
		v 3.73	3.85	4.04	4.33	4.62	4.89	5.17	5.44	5.96	6.48
180	373.1	h 1189.6	1201.1	1217.9	1244.1	1269.3	1294.1	1318.4	1342.7	1391.0	1439.4
		n 1.5873	1.6016	1.6216	1.6517	1.6789	1.7041	1.7280	1.7505	1.7924	1.8311
200	381.9	v 3.22	3.32	3.49	3.75	4.00	4.24	4.48	4.71	5.16	5.61
		h 1192.2	1204.3	1221.4	1248.0	1273.3	1298.2	1322.6	1346.9	1395.4	1443.8
220	389.9	n 1.5747	1.5894	1.6096	1.6395	1.6666	1.6916	1.7152	1.7376	1.7792	1.8177
		v 2.83	2.93	3.07	3.30	3.53	3.74	3.95	4.15	4.56	4.95
240	397.4	h 1194.5	1207.0	1224.5	1251.3	1276.8	1301.7	1326.2	1350.6	1399.3	1447.9
		n 1.5639	1.5789	1.5993	1.6292	1.6561	1.6810	1.7043	1.7266	1.7680	1.8063
260	404.5	v 2.53	2.62	2.75	2.96	3.16	3.35	3.54	3.72	4.09	4.44
		h 1196.4	1209.4	1227.2	1254.3	1279.9	1304.8	1329.5	1353.9	1402.7	1451.4
280	411.2	n 1.5543	1.5697	1.5904	1.6201	1.6468	1.6716	1.6948	1.7169	1.7581	1.7962
		v 2.29	2.37	2.49	2.68	2.86	3.04	3.21	3.38	3.71	4.03
300	417.5	h 1198.1	1211.6	1229.8	1257.1	1282.6	1307.7	1332.4	1357.0	1405.9	1454.7
		n 1.5456	1.5614	1.5823	1.6120	1.6385	1.6632	1.6862	1.7082	1.7493	1.7872
320	424.1	v 2.09	2.16	2.28	2.45	2.62	2.78	2.94	3.10	3.40	3.69
		h 1199.6	1213.6	1232.2	1259.6	1285.2	1310.3	1335.1	1359.8	1408.8	1457.7
340	431.9	n 1.5379	1.5541	1.5753	1.6049	1.6312	1.6558	1.6787	1.7005	1.7415	1.7792
		v 1.92	1.99	2.09	2.26	2.42	2.57	2.71	2.85	3.13	3.40
360	439.4	h 1200.9	1215.4	1234.3	1261.9	1287.6	1312.8	1337.6	1362.3	1411.5	1460.5
		n 1.5309	1.5476	1.5690	1.5985	1.6246	1.6492	1.6720	1.6937	1.7344	1.7721
380	447.2	v 1.78	1.84	1.94	2.10	2.24	2.39	2.52	2.65	2.91	3.16
		h 1202.1	1217.1	1236.4	1264.1	1289.9	1315.1	1340.0	1364.7	1414.0	1463.2
400	455.0	n 1.5244	1.5416	1.5631	1.5926	1.6186	1.6430	1.6658	1.6874	1.7280	1.7655
		v 1.66	1.72	1.81	1.95	2.09	2.22	2.35	2.48	2.72	2.95
420	462.7	h 1203.1	1218.7	1238.4	1266.2	1291.9	1317.2	1342.2	1367.0	1416.4	1465.7
		n 1.5185	1.5362	1.5580	1.5873	1.6133	1.6375	1.6603	1.6818	1.7223	1.7597
440	470.4	v 1.55	1.60	1.69	1.83	1.96	2.09	2.21	2.33	2.55	2.77
		h 1204.1	1220.2	1240.3	1268.2	1294.0	1319.3	1344.3	1369.2	1418.6	1468.0
460	478.1	n 1.5129	1.5310	1.5530	1.5824	1.6082	1.6323	1.6550	1.6765	1.7168	1.7541
		v 1.33	1.38	1.46	1.58	1.70	1.81	1.92	2.02	2.22	2.41
480	485.8	h 1206.1	1223.9	1244.6	1272.7	1298.7	1324.1	1349.3	1374.3	1424.0	1473.7
		n 1.5002	1.5199	1.5423	1.5715	1.5971	1.6210	1.6436	1.6650	1.7052	1.7422
500	493.5	v 1.17	1.21	1.28	1.40	1.50	1.60	1.70	1.79	1.97	2.14
		h 1207.7	1227.2	1248.6	1276.9	1303.0	1328.6	1353.9	1379.1	1429.0	1478.9
520	501.2	n 1.4894	1.5107	1.5336	1.5625	1.5880	1.6117	1.6342	1.6554	1.6955	1.7323
		v 1.04	1.08	1.14	1.25	1.35	1.44	1.53	1.61	1.77	1.93
540	508.9	h 1209	1231	1252	1281	1307	1333	1358	1383	1434	1484
		n 1.479	1.502	1.526	1.554	1.580	1.603	1.626	1.647	1.687	1.723
560	516.6	v 0.93	0.97	1.03	1.13	1.22	1.31	1.39	1.47	1.62	1.76
		h 1210	1233	1256	1285	1311	1337	1362	1388	1438	1489
580	524.3	n 1.470	1.496	1.519	1.548	1.573	1.597	1.619	1.640	1.679	1.715

## FLOW OF STEAM.

**Flow of Steam through a Nozzle.** (From Clark on the Steam-engine.) — The flow of steam of a greater pressure into an atmosphere of a less pressure increases as the difference of pressure is increased, until the external pressure becomes only 58% of the absolute pressure in the boiler. The flow of steam is neither increased nor diminished by the fall of the external pressure below 58%, or about  $\frac{4}{7}$  of the inside pressure, even to the extent of a perfect vacuum. In flowing through a nozzle of the best form, the steam expands to the external pressure, and to the volume due to this pressure, so long as it is not less than 58% of the internal pressure. For an external pressure of 58%, and for lower percentages, the ratio of expansion is 1 to 1.624.

When steam of varying initial pressures is discharged into the atmosphere — the atmospheric pressure being not more than 58% of the initial pressure — the velocity of outflow at constant density, that is, supposing the initial density to be maintained, is given by the formula  $V = 3.5953 \sqrt{h}$ .  $V$  = velocity in feet per second, as for steam of the initial density;

$h$  = the height in feet of a column of steam of the given initial pressure, the weight of which is equal to the pressure on the unit of base.

The lowest initial pressure to which the formula applies, when the steam is discharged into the atmosphere at 14.7 lbs. per sq. in., is  $(14.7 \times 100/58) = 25.37$  lbs. per sq. in.

From the contents of the table below it appears that the velocity of outflow into the atmosphere, of steam above 25 lbs. per sq. in. absolute pressure, increases very slowly with the pressure, because the density, and the weight to be moved, increase with the pressure. An average of 900 ft. per sec. may, for approximate calculations, be taken for the velocity of outflow as for constant density, that is, taking the volume of the steam at the initial volume. For a fuller discussion of this subject see "Steam Turbines, page 1085.

**Outflow of Steam into the Atmosphere.** — External pressure per square inch, 14.7 lbs. absolute. Ratio of expansion in nozzle, 1.624.

Absolute Initial Pressure per square inch.	Velocity of Outflow as at Constant Density.	Actual Velocity of Outflow Expanded.	Discharge per square inch of Orifice per min.	Horse-power per sq. in. of Orifice if H.P. = 30 lbs. per hour.	Absolute Initial Pressure per square inch.	Velocity of Outflow as at Constant Density.	Actual Velocity of Outflow Expanded.	Discharge per square inch of Orifice per minute.	Horse-power per sq. in. of Orifice if H.P. = 30 lbs. per hour.
lbs.	feet p.sec.	feet per sec.	lbs.	H.P.	lbs.	feet p.sec.	feet per sec.	lbs.	H.P.
25.37	863	1401	22.81	45.6	90	895	1454	77.94	155.9
30	867	1408	26.84	53.7	100	898	1459	86.34	172.7
40	874	1419	35.18	70.4	115	902	1466	98.76	197.5
50	880	1429	44.06	88.1	135	906	1472	115.61	231.2
60	885	1437	52.59	105.2	155	910	1478	132.21	264.4
70	889	1444	61.07	122.1	165	912	1481	140.46	280.9
75	891	1447	65.30	130.6	215	919	1493	181.58	363.2

**Rateau's Formula.** — A. Rateau, in 1895-6, made experiments with converging nozzles 0.41, 0.59 and 0.95 in. diam., on steam of pressures from 1.4 to 170 lbs. per sq. in. In his paper read at the Intl. Eng'g. Congress at Glasgow (*Eng. Rec.*, Oct. 16, 1901) he gives the following formula, applicable when the final pressure, absolute, is less than 58% of the initial. Pounds per hour per sq. in. area of orifice =  $3.6 P (16.3 - 0.96 \log P)$ .  $P$  = absolute pressure, lbs. per sq. in.

**Napier's Approximate Rule.** — Flow in pounds per second = absolute pressure  $\times$  area in square inches  $\div$  70. This rule gives results

which closely correspond with those in the above table, and with results computed by Rateau's formula, as shown below.

Abs. press., lbs. per sq. in. ....	25.37	40	60	75	100	135	165	215
Discharge per min., by table, lbs. ....	22.81	35.18	52.59	65.30	86.34	115.61	140.46	181.58
By Rateau's for- mula. ....	22.76	35.43	52.49	65.25	86.28	115.47	140.28	181.39
By Napier's rule.	21.74	34.29	51.43	64.29	85.71	115.71	141.43	184.29

**Flow of Steam in Pipes.**—The commonly accepted formula for

flow of air, steam or gas in pipes is  $W = c \sqrt{\frac{w (p_1 - p_2) d^5}{L}}$ , in which

$W$  = the weight in pounds per minute,  $p_1$  and  $p_2$  = initial and final pressures in pounds per square inch,  $w$  = density in pounds per cubic foot,  $d$  = internal diameter of the pipe in inches, and  $L$  = length in feet, and  $c$  an experimental coefficient, which varies with the diameter of the pipe. It varies also with the velocity and with the smoothness of the pipe, but there are no authentic data for the amount of the variations due to these causes. For the derivation of the formula, see *Ency. Brit.*, 11th ed., vol. xiv, p. 67, also "Steam," 1913 edition, published by the Babcock & Wilcox Co.

The value of the coefficient  $c$ , as deduced by G. H. Babcock from a study of published experiments, is  $87 \sqrt{\frac{1}{1 + 3.6/d}}$ . It is probably as

nearly correct as can be derived from the few experimental records that are available. For the different standard sizes of lap welded pipe the value of  $c$  computed from Babcock's formula are as below:

VALUES OF  $c$  FOR STANDARD SIZES OF LAP-WELDED PIPE.

Size, In.	Inter. Diam., In.	$c$	Size, In.	Inter. Diam., In.	$c$	Size, In.	Inter. Diam., In.	$c$
1/2	0.622	33.4	4	4.026	63.2	12	12.00	76.3
3/4	0.824	37.5	4 1/2	4.506	64.8	13	13.25	77.1
1	1.049	41.3	5	5.047	66.5	14	14.25	77.7
1 1/4	1.380	45.8	6	6.065	68.7	15	15.25	78.2
1 1/2	1.610	48.4	7	7.023	70.7	17 O.D.	16.214	78.7
2	2.067	52.5	8	7.981	72.2	18 O.D.	17.182	79.1
2 1/2	2.469	55.5	9	8.941	73.4	20 O.D.	19.182	79.8
3	3.068	59.0	10	10.02	74.5	22 O.D.	21.25	80.4
3 1/2	3.548	61.3	11	11.00	75.5	24 O.D.	23.25	81.0

The table, page 878, calculated from the formula with the above values of  $c$  gives the flow of steam in pounds per minute for a drop of 1 lb. pressure per 1000 ft. of length. For any other ratio of drop to length multiply the figures in the table by the factors given below.

FACTORS FOR CORRECTION OF TABLE OF FLOW OF STEAM.

Drop lb. per 1000 ft.	1/4	1/2	2	3	4	6	8	10	15	20	25
Factor	0.5	0.707	1.414	1.732	2	2.45	2.83	3.16	3.87	4.47	5

For Flow of Steam at low pressures, see Heating and Ventilation, page 699.

**Flow of Steam in Long Pipes. Ledoux's Formula.**—In the flow of steam or other gases in long pipes, the volume and the velocity are increased as the drop in pressure increases. Taking this into account a correct formula for flow would be an exponential one. Ledoux gives

$$d = 0.699 \sqrt[5]{\frac{W^2 L}{p_1^{1.94} - p_2^{1.94}}}$$

his notation being reduced to English measures. (*Annales des Mines*, 1892; *Trans. A. S. M. E.*, xx., 365; *Power*, June, 1907.) See Johnson's formula for flow of air, page 619.



Flow of Steam in Pipes, for a drop of 1 lb. per 1000 ft. length. Pounds per minute.  
 ( $p_1$  = initial pressure, by gauge, lb. per sq. in.;  $w$  = density, lb. per cu. ft. For formula see p. 877.)

Nomi- nal Diam. of Pipe, In.	Actual Inter- nal Diam. $d$	$p_1 = 0.3$ $w = .03732$	$p_1 = 2.3$ $w = .04277$	$p_1 = 5.3$ $w = .04980$	$p_1 = 10.3$ $w = .0614$	$p_1 = 50.3$ $w = .1503$	$p_1 = 100.3$ $w = .2577$	$p_1 = 150.3$ $w = .3633$	$p_1 = 200.3$ $w = .468$	$p_1 = 250.3$ $w = .571$
1/2	0.622	0.017	0.067	0.072	0.080	0.123	0.163	0.195	0.222	0.245
3/4	0.824	.039	.151	.163	.181	.283	.380	.442	.500	.552
1	1.049	.079	.305	.328	.365	.571	.747	.887	1.007	1.112
1 1/4	1.380	.173	.670	.723	.803	1.256	1.645	1.953	2.217	2.448
1 1/2	1.610	.269	1.041	1.123	1.247	1.952	2.556	3.034	3.444	3.804
2	2.067	.545	2.110	2.276	2.527	3.954	5.177	6.147	6.977	7.706
2 1/2	2.469	.898	3.478	3.751	4.166	6.517	8.534	10.13	11.50	12.70
3	3.068	1.642	6.364	6.865	7.622	11.93	15.62	18.54	21.04	23.24
3 1/2	3.548	2.450	9.508	10.26	11.40	17.81	23.32	27.71	31.43	34.74
4	4.026	3.471	13.45	14.51	16.11	25.20	33.00	39.18	44.47	49.12
4 1/2	4.506	4.712	18.27	19.73	21.91	34.28	44.88	53.29	60.48	66.81
5	5.047	6.425	24.90	26.85	29.82	46.65	61.09	72.53	82.32	90.93
6	6.065	10.51	40.72	43.92	48.77	76.30	99.91	118.6	134.6	148.7
7	7.023	15.60	60.46	65.21	72.41	113.3	148.3	176.1	199.9	220.8
8	7.981	22.00	85.23	91.97	102.0	159.7	209.2	248.4	281.9	311.2
9	8.941	29.63	114.7	123.8	137.5	215.1	281.6	334.4	379.6	418.8
10	10.020	39.98	154.9	167.0	185.5	290.3	380.1	451.3	512.2	565.8
11	11.000	51.16	198.2	213.8	237.4	371.5	486.4	577.5	655.5	723.2
12	12.000	64.26	249.0	268.6	298.2	466.6	611.0	725.5	823.4	909.5
13	13.250	83.20	322.3	347.7	386.1	604.1	791.0	939.2	1066.	1177.
14	14.250	100.6	389.6	420.3	466.7	730.2	956.1	1135.	1288.	1423.
15	15.250	119.9	464.6	501.2	556.5	870.7	1140.	1354.	1538.	1697.
17 O.D.	16.214	140.6	544.9	587.9	652.7	1021.	1337.	1588.	1802.	1990.
18 O.D.	17.182	163.4	634.7	683.1	758.5	1187.	1554.	1845.	2094.	2313.
20 O.D.	19.182	217.1	841.4	907.6	1008.	1577.	2065.	2451.	2782.	3074.
22 O.D.	21.250	282.6	1095.	1181.	1311.	2052.	2687.	3190.	3621.	3999.
24 O.D.	23.250	356.5	1381.	1490.	1654.	2588.	3389.	4024.	4567.	5045.

**Carrying Capacity of Extra Heavy Steam Pipes.**  
(Power Specialty Co.)

Nominal size of pipe, in.	Actual in-side area in sq. in.	200	150	100	50	Nominal size of pipe, in.	Actual in-side area in sq. in.	200	150	100	50
		lbs.	lbs.	lbs.	lbs.			lbs.	lbs.	lbs.	lbs.
Pounds of steam per hour.						Pounds of steam per hour.					
1	0.71	1210	872	618	362	6	25.93	40800	31600	22600	13210
1 1/4	1.27	2000	1555	1105	646	7	34.47	54600	42250	30000	17600
1 1/2	1.75	2750	2140	1525	894	8	44.18	69500	54000	38400	22450
2	2.93	4610	3590	2550	1525	9	58.42	92000	71500	50800	29800
2 1/2	4.20	6610	5150	3660	2140	10	74.66	117300	91500	65000	38100
3	6.56	10300	8050	5720	3450	11	90.76	142800	111500	79200	46300
3 1/2	8.85	13900	10820	7720	4520	12	108.43	170500	133000	94750	55400
4	11.44	18000	14000	10000	5850	14	153.94	242000	188200	133900	78600
4 1/2	14.18	22300	17350	12320	7230	16	176.71	277500	216200	153800	90500
5	18.19	28610	22250	15800	9300	18	226.98	357000	278000	197500	115700

The quantities in the above table are based on the following velocities:  
 Steam superheated degrees F. 0 50 100 150 200 250  
 Velocity, ft. per min. . . . . 8000 8500 8950 9450 9900 10450

**Resistance to Flow by Bends, Valves, etc.** (From Briggs on Warming Buildings by Steam.) — The resistance at the entrance to a tube when no special bell-mouth is given consists of two parts. The head  $v^2 \div 2g$  is expended in giving the velocity of flow; and the head  $0.505 v^2 \div 2g$  in overcoming the resistance of the mouth of the tube. Hence the whole loss of head at the entrance is  $1.505 v^2 \div 2g$ . This resistance is equal to the resistance of a straight tube of a length equal to about 60 times its diameter. The loss at each sharp right-angled elbow is the same as in flowing through a length of straight tube equal to about 40 times its diameter. For a globe steam stop-valve the resistance is taken to be  $1\frac{1}{2}$  times that of the right-angled elbow.

**Sizes of Steam-pipes for Stationary Engines.** — An old common rule is that steam-pipes supplying engines should be of such size that the mean velocity of steam in them does not exceed 6000 feet per minute, in order that the loss of pressure due to friction may not be excessive. The velocity is calculated on the assumption that the cylinder is filled at each stroke. In modern practice with large engines and high pressures, this rule gives unnecessarily large and costly pipes. For such engines the allowable drop in steam pressure should be assumed and the diameter calculated by means of the formulæ given above.

An article in *Power*, May, 1893, on proper area of supply-pipes for engines gives a table showing the practice of leading builders. To facilitate comparison, all the engines have been rated in horse-power at 40 pounds mean effective pressure. The table contains all the varieties of simple engines, from the slide-valve to the Corliss, and it appears that there is no general difference in the sizes of pipe used in the different types.

The averages selected from this table are as follows:  
**DIAMETERS OF CYLINDERS CORRESPONDING TO VARIOUS SIZES OF STEAM-PIPES BASED ON PISTON-SPEED OF ENGINE OF 600 FT. PER MINUTE, AND ALLOWABLE MEAN VELOCITY OF STEAM IN PIPE OF 4000, 6000, AND 8000 FT. PER MINUTE. (STEAM ASSUMED TO BE ADMITTED DURING FULL STROKE.)**

Diam. of pipe, inches. . . . .	2	2 1/2	3	3 1/2	4	4 1/2	5	6
Vel. 4000 . . . . .	5.2	6.5	7.7	9.0	10.3	11.6	12.9	15.5
Vel. 6000 . . . . .	6.3	7.9	9.5	11.1	12.6	14.2	15.8	19.0
Vel. 8000 . . . . .	7.3	9.1	10.9	12.8	14.6	16.4	18.3	21.9
Horse-power, approx. . . . .	20	31	45	62	80	100	125	180
Diam. of pipes, inches. . . . .	7	8	9	10	11	12	13	14
Vel. 4000 . . . . .	18.1	20.7	23.2	25.8	28.4	31.0	33.6	36.1
Vel. 6000 . . . . .	22.1	25.3	28.5	31.6	34.8	37.9	41.1	44.3
Vel. 8000 . . . . .	25.6	29.2	32.9	36.5	40.2	43.8	47.5	51.1
Horse-power, approx. . . . .	245	320	406	500	606	718	845	981

Formula. Area of pipe =  $\frac{\text{Area of cylinder} \times \text{piston-speed.}}{\text{mean velocity of steam in pipe}}$   
 For piston-speed of 600 ft. per min. and velocity in pipe of 4000, 6000,

and 8000 ft. per min., area of pipe = respectively 0.15, 0.10, and  $0.075 \times$  area of cylinder. Diam. of pipe = respectively 0.3873, 0.3162, and  $0.2739 \times$  diam. of cylinder. The reciprocals of these are 2.582, 3.162 and 3.651.

The first line in the above table may be used for proportioning exhaust pipes, in which a velocity not exceeding 4000 ft. per minute is advisable. The last line, approx. H.P. of engine, is based on the velocity of 6000 ft. per min. in the pipe, using the corresponding diameter of piston, and taking  $H.P. = \frac{1}{2} (\text{diam. of piston in inches})^2$ .

**Sizes of Steam-pipes for Marine Engines.** — In marine-engine practice the steam-pipes are generally not as large as in stationary practice for the same sizes of cylinder. Seaton gives the following rules:

*Main Steam-pipes* should be of such size that the mean velocity of flow does not exceed 8000 ft. per min.

In large engines, 1000 to 2000 H.P., cutting off at less than half stroke, the steam-pipe may be designed for a mean velocity of 9000 ft., and 10,000 ft. for still larger engines.

In small engines and engines cutting off later than half stroke, a velocity of less than 8000 ft. per minute is desirable.

Taking 8100 ft. per min. as the mean velocity,  $S$  speed of piston in feet per min., and  $D$  the diameter of the cylinder,

$$\text{Diam. of main steam-pipe} = \sqrt{D^2 S \div 8100} = D \sqrt{S \div 90}.$$

*Stop and Throttle Valves* should have a greater area of passages than the area of the main steam-pipe, on account of the friction through the circuitous passages. The shape of the passages should be designed so as to avoid abrupt changes of direction and of velocity of flow as far as possible.

*Area of Steam Ports and Passages* =

$$\frac{\text{Area of piston} \times \text{speed of piston in ft. per min.}}{6000} = \frac{(\text{Diam.})^2 \times \text{speed}}{7639}.$$

*Opening of Port to Steam.* — To avoid wire-drawing during admission the area of opening to steam should be such that the mean velocity of flow does not exceed 10,000 ft. per min. To avoid excessive clearance the width of port should be as short as possible, the necessary area being obtained by length (measured at right angles to the line of travel of the valve). In practice this length is usually 0.6 to 0.8 of the diameter of the cylinder, but in long-stroke engines it may equal or even exceed the diameter.

*Exhaust Passages and Pipes.* — The area should be such that the mean velocity of the steam should not exceed 6000 ft. per min., and the area should be greater if the length of the exhaust-pipe is comparatively long. The area of passages from cylinders to receivers should be such that the velocity will not exceed 5000 ft. per min.

The following table is computed on the basis of a mean velocity of flow of 8000 ft. per min. for the main steam-pipe, 10,000 for opening to steam, and 6000 for exhaust.  $A$  = area of piston,  $D$  its diameter.

STEAM AND EXHAUST OPENINGS.

Piston-speed, ft. per min.	Diam. of Steam-pipe $\div D$ .	Area of Steam-pipe $\div A$ .	Diam. of Exhaust $\div D$ .	Area of Exhaust $\div A$ .	Opening to Steam $\div A$ .
300	0.194	0.0375	0.223	0.0500	0.03
400	0.224	0.0500	0.258	0.0667	0.04
500	0.250	0.0625	0.288	0.0833	0.05
600	0.274	0.0750	0.316	0.1000	0.06
700	0.296	0.0875	0.341	0.1167	0.07
800	0.316	0.1000	0.365	0.1333	0.08
900	0.335	0.1125	0.387	0.1500	0.09
1000	0.353	0.1250	0.400	0.1667	0.10

**Proportioning Steam-Pipes for Minimum Total Loss by Radiation and Friction.** — For a given size of pipe and quantity of steam to be carried the loss of pressure due to friction is calculated by formulæ given above, or taken from the tables. The work of friction, being converted into heat, tends to dry or superheat the steam, but its influence is usually so small that it may be neglected. The loss of heat by radiation tends to destroy the superheat and condense some of the steam into water. For



well-covered steam-pipes this loss may be estimated at about 0.3 B.T.U. per sq. ft. of external surface of the pipe per hour per degree of difference of temperature between that of the steam and that of the surrounding atmosphere (see Steam-pipe Coverings, p. 584).

A practical problem in power-plant design is to find the diameter of pipe to carry a given quantity of steam with a minimum total loss of available energy due to both radiation and friction, considering also the money loss due to interest and depreciation on the value of the pipe and covering as erected. Each case requires a separate arithmetical computation, no formula yet being constructed to fit the general case. An approximate method of solution, neglecting the slight gain of heat by the steam from the work of friction, and assuming that the water condensed by radiation of heat is removed by a separator and lost, is as follows: Calculate the amount of steam required by the engine, in pounds per minute. From a steam pipe formula or table find the several drops of pressure, in lbs. per sq. in., in pipes of different assumed diameters, for the given quantity of steam and the given length of pipe. Compute from a theoretical indicator diagram of steam expanding in the engine the loss of available work done by 1 lb. of steam, due to the several drops already found, and the corresponding fraction of 1 lb. of steam that will have to be supplied to make up for this loss of work. State this loss as equivalent to so many pounds of steam per 1000 lbs. of steam carried. Calculate the loss in lbs. of steam condensed by radiation in the pipes of the different diameters, per 1000 lbs. carried. Add the two losses together for each assumed size of pipe, and by inspection find which pipe gives the lowest total loss. The money loss due to cost and depreciation may also be figured approximately in the same unit of lbs. of steam lost per 1000 lbs. carried, by taking the cost of the covered pipe, assuming a rate of interest and depreciation, finding the annual loss in cents, then from the calculated value of steam, which depends on the cost of fuel, find the equivalent quantity of steam which represents this money loss, and the equivalent lbs. of steam per 1000 lbs. carried. This is to be added to the sum of the losses due to friction and radiation, and it will be found to modify somewhat the conclusion as to the diameter of pipe and the drop which corresponds to a minimum total loss.

Instead of determining the loss of available work per pound of steam from theoretical indicator diagrams, it may be computed approximately on the assumption, based on the known characteristics of the engine, that its efficiency is a certain fraction of that of an engine working between the same limits of temperature on the ideal Carnot cycle, as shown in the table below, and from the efficiency thus found, compared with the efficiency at the given initial pressure less the drop, the loss of work may be calculated.

AVAILABLE MAXIMUM THERMAL EFFICIENCY OF STEAM EXPANDED BETWEEN THE GIVEN PRESSURES AND 1 LB. ABSOLUTE, BASED ON THE CARNOT CYCLE.  $(E = T_1 - T_2) \div T_1$ .

Initial Pressure less than Maxi- mum, Lbs.	Maximum Initial Absolute Pressures.									
	100	125	150	175	200	225	250	275	300	
	Maximum Thermal Efficiency.									
0	0.287	0.302	0.314	0.324	0.333	0.341	0.348	0.354	0.360	
2	.286	.301	.313	.323	.332	.340	.347	.354	.359	
5	.284	.299	.312	.322	.331	.339	.346	.353	.359	
10	.280	.296	.309	.320	.329	.337	.345	.352	.358	
20	.272	.290	.304	.316	.326	.335	.342	.349	.356	

This table shows that if the initial steam pressure is lowered from 100 lbs. to 80 lbs., the efficiency of the Carnot cycle is reduced from 0.287 to 0.272, or over 5%, but if steam of 300 lbs. is lowered to 280 lbs. the efficiency is reduced only from 0.360 to 0.356 or 1.1%. With high-pressure steam, therefore, much greater loss of pressure by friction of steam pipes, valves and ports is allowable than with steam of low pressure.

Theoretically the loss of efficiency due to drop in pressure on account of friction of pipes should be less than that indicated in the above table, since the work of friction tends to superheat the steam, but practically most, if not all, of the superheating is lost by radiation.

By a method of calculation somewhat similar to that above outlined, the following figures were found, in a certain case, of the cost per day of the transmission of 50,000 lbs. of steam per hour a distance of 1000 feet, with 100 lbs. initial pressure.

Diameter of Pipe.	6 in.	7 in.	8 in.	10 in.	12 in.
1. Interest, etc., 12% per annum..	\$0.39	\$0.46	\$0.53	\$0.66	\$0.84
2. Condensation.....	1.51	1.76	2.01	2.51	3.02
3. Friction.....	0.86	0.38	0.19	0.06	0.02
Total per day.....	\$2.76	\$2.60	\$2.73	\$3.23	\$3.88

### STEAM-PIPES.

**Bursting-tests of Copper Steam-pipes.** (From Report of Chief Engineer Melville, U. S. N., for 1892.) — Some tests were made at the New York Navy Yard which show the unreliability of brazed seams in copper pipes. Each pipe was 8 in. diameter inside and 3 ft. 1<sup>5</sup>/<sub>8</sub> in. long. Both ends were closed by ribbed heads and the pipe was subjected to a hot-water pressure, the temperature being maintained constant at 371° F. Three of the pipes were made of No. 4 sheet copper (Stubs gauge) and the fourth was made of No. 3 sheet.

The following were the results, in lbs. per sq. in., of bursting-pressure:

Pipe number.....	1	2	3	4	4'
Actual bursting-strength..	835	785	950	1225	1275
Calculated " ".....	1336	1336	1569	1568	1568
Difference.....	501	551	619	343	293

The tests of specimens cut from the ruptured pipes show the injurious action of heat upon copper sheets; and that, while a white heat does not change the character of the metal, a heat of only slightly greater degree causes it to lose the fibrous nature that it has acquired in rolling, and a serious reduction in its tensile strength and ductility results.

**A Failure of a Brazed Copper Steam-pipe on the British steamer *Prodano*** was investigated by Prof. J. O. Arnold. He found that the brazing was originally sound, but that it had deteriorated by oxidation of the zinc in the brazing alloy by electrolysis, which was due to the presence of fatty acids produced by decomposition of the oil used in the engines. A full account of the investigation is given in *The Engineer*, April 15, 1898.

**Reinforcing Steam-pipes.** (*Eng.*, Aug. 11, 1893.) — In the Italian Navy copper pipes above 8 in. diam. are reinforced by wrapping them with a close spiral of copper or Delta-metal wire. Two or three independent spirals are used for safety in case one wire breaks. They are wound at a tension of about 1<sup>1</sup>/<sub>2</sub> tons per sq. in.

**Materials for Pipes and Valves for Superheated Steam.** (M. W. Kellogg, *Trans. A. S. M. E.*, 1907.) — The latest practice is to do away with fittings entirely on high-pressure steam lines and put what are known as "nozzles" on the piping itself. This is accomplished by welding wrought-steel pipe on the side of another section, so as to accomplish the same result as a fitting. In this way rolled or cast steel flanges and a Rockwood or welded joint can be used. This method has three distinct advantages: 1. The quality of the metal used. 2. The lightening of the entire work. 3. The doing away with a great many joints.

As a general average, at least 50% of the joints can be left out; sometimes the proportion runs up as high as 70%.

Above 575° F. the limit of elasticity in cast iron is reached with a pressure varying from 140 to 175 pounds. Under such conditions the material is strained and does not resume its former shape, eventually showing surface cracks which increase until the pipe breaks. [This statement concerning cast iron does not seem to agree with the one on page 439, to the effect that no diminution in its strength takes place under 900° F.]

Tests by Bach on cast steel show that at 572° F. the reduction in breaking strength amounts only to 1.1% and at 752° F. to about 8%.

The effect of temperature on nickel is similar to that on cast steel and in consequence this material is very suitable for use in connection with

highly superheated steam. Bach recommends that bronze alloys be done away with for use on steam lines above a temperature of about 390° F.

The old-fashioned screwed joint, no matter how well made, is not suitable for superheated steam work.

In making up a joint, the face of all flanges or pipe where a joint is made should be given a fine tool finish and a plane surface, and a gasket should be used. The best results have been obtained with a corrugated soft Swedish steel gasket with "Smooth-on" applied, and with the McKim gasket, which is of copper or bronze surrounding asbestos. On superheated steam lines a corrugated copper gasket will in time pit out in some part of the flange nearly through the entire gasket.

Specifications for pipes and fittings for superheated steam service were published by Crane Co., Chicago, in the *Valve World*, 1907.

**Riveted Steel Steam-pipes** have been used for high pressures. See paper on A Method of Manufacture of Large Steam-pipes, by Chas. H. Manning, *Trans. A. S. M. E.*, vol. xv.

**Valves in Steam-pipes.** — Should a globe-valve on a steam-pipe have the steam-pressure on top or underneath the valve is a disputed question. With the steam-pressure on top, the stuffing-box around the valve-stem cannot be repacked without shutting off steam from the whole line of pipe; on the other hand, if the steam-pressure is on the bottom of the valve it all has to be sustained by the screw-thread on the valve-stem, and there is danger of stripping the thread.

A correspondent of the *American Machinist*, 1892, says that it is a very uncommon thing in the ordinary globe-valve to have the thread give out, but by water-hammer and merciless screwing the seat will be crushed down quite frequently. Therefore with plants where only one boiler is used he advises placing the valve with the boiler-pressure underneath it. On plants where several boilers are connected to one main steam-pipe he would reverse the position of the valve, then when one of the valves needs repacking the valve can be closed and the pressure in the boiler whose pipe it controls can be reduced to atmospheric by lifting the safety-valve. The repacking can then be done without interfering with the operation of the other boilers of the plant.

He proposes also the following other rules for locating valves: Place valves with the stems horizontal to avoid the formation of a water-pocket. Never put the junction-valve close to the boiler if the main pipe is above the boiler, but put it on the highest point of the junction-pipe. If the other plan is followed, the pipe fills with water whenever this boiler is stopped and the others are running, and breakage of the pipe may cause serious results. Never let a junction-pipe run into the bottom of the main pipe, but into the side or top. Always use an angle-valve where convenient, as there is more room in them. Never use a gate valve under high pressure unless a by-pass is used with it. Never open a blow-off valve on a boiler a little and then shut it; it is sure to catch the sediment and ruin the valve; throw it well open before closing. Never use a globe-valve on an indicator-pipe. For water, always use gate or angle valves or stop-cocks to obtain a clear passage. Buy if possible valves with renewable disks. Lastly, never let a man go inside a boiler to work, especially if he is to hammer on it, unless you break the joint between the boiler and the valve and put a plate of steel between the flanges.

The "Steam-Loop" is a system of piping by which water of condensation in steam-pipes is automatically returned to the boiler. In its simplest form it consists of three pipes, which are called the riser, the horizontal, and the drop-leg. When the steam-loop is used for returning to the boiler the water of condensation and entrainment from the steam-pipe through which the steam flows to the cylinder of an engine, the riser is generally attached to a separator; this riser empties at a suitable height into the horizontal, and from thence the water of condensation is led into the drop-leg, which is connected to the boiler, into which the water of condensation is fed as soon as the hydrostatic pressure in the drop-leg in connection with the steam-pressure in the pipes is sufficient to overcome the boiler-pressure. The action of the device depends on the following principles: Difference of pressure may be balanced by a water-column; vapors or liquids tend to flow to the point of lowest pressure; rate of flow depends on difference of pressure and mass; decrease of static pressure in a steam-pipe or chamber is proportional to rate of conden-



sation; in a steam-current water will be carried or swept along rapidly by friction. (Illustrated in *Modern Mechanism*, p. 807. Patented by J. H. Blessing, Feb. 13, 1872, Dec. 28, 1883.) Mr. Blessing thus describes the operation of the loop in *Eng. Review*, Sept., 1907.

The heating system is so arranged that the water of condensation from the radiators gravitates towards some low point and thence is led into the top of a receiver. After this is done it is found that owing to friction caused by the velocity of the steam passing through the different pipes and condensation due to radiation, the steam pressure in the small drip receiver is much less than that in the boiler. This difference will determine the height, or the length of the loop, that must be employed so that the water will gravitate through it into the boiler; that is to say, if there is 10 lbs. difference in pressure, the descending leg of the loop should extend about 30 feet above the water-level in the boiler, since a column of water 2.3 ft. is equal to 1 lb. pressure, and a difference in pressure of 10 lbs. would require a column 23 ft. high. If we make the loop 30 feet high we shall have an additional length of 7 ft. with which to overcome friction. The water, after it reaches the top of the loop, composed of a larger section of pipe, will flow into the boiler through the descending leg with a velocity due to the extra 7 ft. added to the discharging leg.

**Loss from an Uncovered Steam-pipe.** (Bjorling on Pumping-engines.) — The amount of loss by condensation in a steam-pipe carried down a deep mine-shaft has been ascertained by actual practice at the Clay Cross Colliery, near Chesterfield, where there is a pipe 7½ in. internal diam., 1100 ft. long. The loss of steam by condensation was ascertained by direct measurement of the water deposited in a receiver, and was found to be equivalent to about 1 lb. of coal per I.H.P. per hour for every 100 ft. of steam-pipe; but there is no doubt that if the pipes had been in the up-cast shaft, and well covered with a good non-conducting material, the loss would have been less. (For Steam-pipe Coverings, see p. 584, *ante*.)

**Condensation in an Underground Pipe Line.** (W. W. Christie, *Eng. Rec.*, 1904.) — A length of 300 ft. of 4-in. pipe, enclosed in a box of 1¼-in. planks, 10 ins. square inside, and packed with mineral wool, was laid in a trench, the upper end being 1 ft. and the lower end 5 ft. below the surface. With 80 lbs. gauge pressure in the pipe the condensation was equivalent to 0.275 B.T.U. per minute per sq. ft. of pipe surface when the outside temperature was 31° F., and 0.222 per min. when the temperature was 62° F.

**Steam Receivers on Pipe Lines.** (W. Andrews, *Steam Eng'g*, Dec. 10, 1902.) — In the four large power houses in New York City, with an ultimate capacity of 60,000 to 100,000 H.P. each, the largest steam mains are not over 20 ins. in diameter. Some of the best plants have pipes which run from the header to the engine two sizes smaller than that called for by the engine builders. These pipes before reaching the engine are carried into a steel receiver, which acts also as a separator. This receiver has a cubical capacity of three times that of the high-pressure cylinder and is placed as close as possible to the cylinder. The pipe from the receiver to the cylinder is of the full size called for by the engine builder. The objects of this arrangement are: First, to have a full supply of steam to the throttle; second, to provide a cushion near the engine on which the cut-off in the steam chest may be spent, thereby preventing vibrations from being transmitted through the piping system; and third, to produce a steady and rapid flow of steam in one direction only, by having a small pipe leading into the receiver. The steam flows rapidly enough to make good the loss caused during the first quarter of the stroke. Plants fitted up in this way are successfully running where the drop in steam pressure is not greater than 4 lbs., although the engines are 500 ft. away from the boilers.

**Equation of Pipes.** — For determining the number of small sized pipes that are equal in carrying capacity to one of greater size the table given under *Flow of Air*, page 625, is commonly used. It is based on the equation  $N = \sqrt{d^5 + d_1^5}$ , in which  $N$  is the number of smaller pipes of diameter  $d_1$  equal in capacity to one pipe of diameter  $d$ . A more accurate equation, based on Unwin's formula for flow of fluids, is  $N = \frac{d^3 \sqrt{d_1 + 3.6}}{d_1^3 \sqrt{d + 3.6}}$ ; ( $d$  and  $d_1$  in inches). For  $d = 2d_1$ , the first formula gives

$N = 5.7$ , and the second  $N = 6.15$ , an unimportant difference, but for  $d = 8d_1$ , the first gives  $N = 181$  and the second  $N = 274$ , a considerable difference. (G. F. Gebhardt, *Power*, June, 1907).

**Identification of Power House Piping by Different Colors.** (W. H. Bryan, *Trans. A. S. M. E.*, 1908.) — In large power plants the multiplicity of pipe lines carrying different fluids causes confusion and may lead to danger by an operator opening a wrong valve. It has therefore become customary to paint the different lines of different colors. The paper gives several tables showing color schemes that have been adopted in different plants. The following scheme, adopted at the New York Edison Co.'s Waterside Station, is selected as an example.

Pipe Lines.	Colors of Pipe.	Bands, Couplings, Valves, etc.
Steam, high pressure to engines, boiler cross-overs, leaders and headers.....	Black	Brass
All other steam lines.....	Buff	Black
Steam, exhaust.....	Orange	Red
Steam, drips including traps.....	Orange	Black
Steam trap discharge.....	Green	Black
Blow-offs, drips from water columns and low-pressure drips.....	Slate	Red
Drains from crank pits.....	Dark Brown	Blue
Cold water to primary heaters and jacket pumps.....	Blue	Red
Feed-water, pumps to boilers.....	Maroon	Same
Hot-water mains, primary heaters to pumps, and cooling-water returns....	Green	Red
Air pump discharge to hot well.....	Slate	Black
Cooling water, pumps to engines.....	Blue	Black
Fire lines.....	Vermilion	Same
Cylinder oil, high pressure.....	Brown	Black
Cylinder oil, low pressure.....	Brown	Green
Engine oil.....	Brown	Red
Pneumatic system.....	Black	Same

## THE STEAM-BOILER.

**The Horse-power of a Steam-boiler.** — The term horse-power has two meanings in engineering: *First*, an absolute unit or measure of the rate of work, that is, of the work done in a certain definite period of time, by a source of energy, as a steam-boiler, a waterfall, a current of air or water, or by a prime mover, as a steam-engine, a water-wheel, or a wind-mill. The value of this unit, whenever it can be expressed in foot-pounds of energy, as in the case of steam-engines, water-wheels, and waterfalls, is 33,000 foot-pounds per minute. In the case of boilers, where the work done, the conversion of water into steam, cannot be expressed in foot-pounds of available energy, the usual value given to the term horse-power is the evaporation of 30 lbs. of water of a temperature of 100° F. into steam at 70 lbs. pressure above the atmosphere. Both of these units are arbitrary; the first, 33,000 foot-pounds per minute, first adopted by James Watt, being considered equivalent to the power exerted by a good London draught-horse, and the 30 lbs. of water evaporated per hour being considered to be the steam requirement per indicated horse-power of an average engine (in 1876).

The Committee of Judges of the Centennial Exhibition, 1876, in reporting the trials of competing boilers at that exhibition adopted the unit, 30 lb. of water evaporated into dry steam per hour from feed-water at 100° F., and under a pressure of 70 lb. per square inch above the atmosphere, these conditions being considered by them to represent fairly average practice.

The A. S. M. E. Committee on Boiler Tests, 1884, accepted the same unit, and defined it as equivalent to 34.5 lb. evaporated per hour from a

feed-water temperature of 212° into steam at the same temperature. The committee of 1899 adopted 34.5 lb. per hour, from and at 212°, as the unit of commercial horse-power, and it was reaffirmed in the Boiler Code of the Power Test Committee, 1915. Using the figures for total heat of steam given in Marks and Davis's steam tables (1909), 34 ½ lb. from and at 212°, is equivalent to 33,479 B.T.U. per hour, or to an evaporation of 30.018 lb. from 100° feed-water temperature into steam at 70 lb. pressure.

The second definition of the term horse-power is an approximate measure of the size, capacity, value, or "rating" of a boiler, engine, water-wheel, or other source or conveyer of energy, by which measure it may be described, bought and sold, advertised, etc. No definite value can be given to this measure, which varies largely with local custom or individual opinion of makers and users of machinery. The nearest approach to uniformity which can be arrived at in the term "horse-power," used in this sense, is to say that a boiler, engine, water-wheel, or other machine, "rated" at a certain horse-power, should be capable of steadily developing that horse-power for a long period of time under ordinary conditions of use and practice, leaving to local custom, to the judgment of the buyer and seller, to written contracts of purchase and sale, or to legal decisions upon such contracts, the interpretation of what is meant by the term "ordinary conditions of use and practice." (*Trans. A. S. M. E.*, vol. vii, p. 226.)

Contracts for power-plant apparatus should specify the leading dimensions of the apparatus and its rated capacity. If a specific guarantee of capacity is made, either working or maximum capacity, the operating conditions under which the guarantee is to be met should be clearly set forth; such, for example, as steam pressure, speed, vacuum, quality of fuel, force of draft, etc. Likewise if a contract contains a guarantee of economy all the conditions should be fully specified.

The commercial rating of capacity determined on for power-plant apparatus, whether for the purpose of contracts for sale or otherwise, should be such that a sufficient reserve capacity beyond the rating is available to meet the contingencies of practical operation; such contingencies, for example, as the loss of steam pressure and capacity due to cleaning fires, inferior coal, oversight of the attendants, sudden demand for an unusual output of steam or power, etc.

The Committee of 1899 says: A boiler rated at any stated capacity should develop that capacity when using the best coal ordinarily sold in the market where the boiler is located, when fired by an ordinary fireman, without forcing the fires, while exhibiting good economy; and further, the boiler should develop at least one-third more than the stated capacity when using the same fuel and operated by the same fireman, the full draught being employed and the fires being crowded; the available draught at the damper, unless otherwise understood, being not less than ½ inch water column.

**Unit of Evaporation.** (Abbreviation, U. E.)—It is the custom to reduce results of boiler-tests to the common standard of the equivalent evaporation from and at the boiling-point at atmospheric pressure, or "from and at 212° F." This unit of evaporation, or one pound of water evaporated from and at 212°, is equivalent to 970.4 British thermal units. 1 B.T.U. = the mean quantity of heat required to raise 1 lb. of water 1° F. between 32° and 212°.

**Measures for Comparing the Duty of Boilers.**—The measure of the efficiency of a boiler is the number of pounds of water evaporated per pound of combustible (coal less moisture and ash), the evaporation being reduced to the standard of "from and at 212°."

The measure of the capacity of a boiler is the amount of "boiler horse-power" developed, a horse-power being defined as the evaporation of 34.5 lb. per hour from and at 212°.

The measure of relative rapidity of steaming of boilers is the number of pounds of water evaporated from and at 212° per hour per square foot of water-heating surface.

The measure of relative rapidity of combustion of fuel in boiler-furnaces is the number of pounds of coal burned per hour per square foot of grate-surface.



**STEAM-BOILER PROPORTIONS.**

**Proportions of Grate and Heating Surface required for a given Horse-power.**—The term horse-power here means capacity to evaporate 34.5 lb. of water from and at 212° F.

Average proportions for maximum economy for land boilers fired with good anthracite coal (ordinary hand firing):

Heating surface per horse-power.....	11.5 sq. ft.
Grate surface per horse-power.....	1/3 "
Ratio of heating to grate surface.....	34.5
Water evap'd from and at 212° per sq. ft. H.S. per hr...	3 lb.
Combustible burned per H.P. per hour.....	3 "
Coal with 1/6 refuse, lb. per H.P. per hour.....	3.6 "
Combustible burned per sq. ft. grate per hour.....	9 "
Coal with 1/6 refuse, lb. per sq. ft. grate per hour....	10.8 "
Water evap'd from and at 212° per lb. combustible....	11.5 "
Water evap'd from and at 212° per lb. coal (1/6 refuse).	9.6 "

**Heating-surface.**— For maximum economy with any kind of fuel a boiler should be proportioned so that at least one square foot of heating-surface should be given for every 3 lbs. of water to be evaporated from and at 212° F. per hour. Still more liberal proportions are required if a portion of the heating-surface has its efficiency reduced by: 1. Tendency of the heated gases to short-circuit, that is, to select passages of least resistance and flow through them with high velocity, to the neglect of other passages. 2. Deposition of soot from smoky fuel. 3. Incrustation. If the heating-surfaces are clean, and the heated gases pass over it uniformly, little if any increase in economy can be obtained by increasing the heating-surface beyond the proportion of 1sq. ft. to every 3 lbs. of water to be evaporated, and with all conditions favorable but little decrease of economy will take place if the proportion is 1 sq. ft. to every 4 lbs. evaporated; but in order to provide for driving of the boiler beyond its rated capacity, and for possible decrease of efficiency due to the causes above named, it is better to adopt 1 sq. ft. to 3 lbs. evaporation per hour as the minimum standard proportion.

Where economy may be sacrificed to capacity, as where fuel is very cheap, it is customary to proportion the heating-surface much less liberally. The following table shows approximately the relative results that may be expected with different rates of evaporation, with anthracite coal.

Lbs. water evapor'd from and at 212° per sq. ft. heating-surface per hour:										
2	2.5	3	3.5	4	5	6	7	8	9	10
Sq. ft. heating-surface required per horse-power:										
17.3	13.8	11.5	9.8	8.6	6.8	5.8	4.9	4.3	3.8	3.5
Ratio of heating to grate surface if 1/3 sq. ft. of G.S. is required per H.P.:										
52	41.4	34.5	29.4	25.8	20.4	17.4	13.7	12.9	11.4	10.5
Probable relative economy:										
100	100	100	95	90	85	80	75	70	65	60
Probable temperature of chimney gases, degrees F.:										
450	450	450	518	585	652	720	787	855	922	990

The relative economy will vary not only with the amount of heating-surface per horse-power, but with the efficiency of that heating-surface as regards its capacity for transfer of heat from the heated gases to the water, which will depend on its freedom from soot and incrustation, and upon the circulation of the water and the heated gases.

With bituminous coal the efficiency will largely depend upon the thoroughness with which the combustion is effected in the furnace.

The efficiency with any kind of fuel will greatly depend upon the amount of air supplied to the furnace in excess of that required to support combustion. With strong draught and thin fires this excess may be great, causing a serious loss of economy. The subject is further discussed below.

**Measurement of Heating-surface.**—The usual rule is to consider as heating-surface all the surfaces that are surrounded by water on one side and by flame or heated gases on the other, using the external instead of the internal diameter of tubes, for greater convenience in calculation, external diameters of boiler-tubes usually being made in even inches or half inches. This method, however, is inaccurate, for the true heating-surface of a tube is the side exposed to the hot gases, the inner surface in a fire-tube boiler and the outer surface in a water-tube boiler. The re-

sistance to the passage of heat from the hot gases on one side of a tube or plate to the water on the other consists almost entirely of the resistance to the passage of the heat from the gases into the metal, the resistance of the metal itself and that of the wetted surface being practically nothing. See paper by C. W. Baker, *Trans. A. S. M. E.*, vol. xix.

**RULE for finding the heating-surface of vertical tubular boilers:** Multiply the circumference of the fire-box (in inches) by its height above the grate; multiply the combined circumference of all the tubes by their length, and to these two products add the area of the lower tube-sheet; from this sum subtract the area of all the tubes, and divide by 144: the quotient is the number of square feet of heating-surface.

**RULE for finding the heating-surface of horizontal tubular boilers:** Take the dimensions in inches. Multiply two-thirds of the circumference of the shell by its length; multiply the sum of the circumferences of all the tubes by their common length; to the sum of these products add two thirds of the area of both tube-sheets; from this sum subtract twice the combined area of all the tubes; divide the remainder by 144 to obtain the result in square feet.

**RULE for finding the square feet of heating-surface in tubes:** Multiply the number of tubes by the diameter of a tube in inches, by its length in feet, and by 0.2618.

**Horse-power, Builder's Rating, Heating-surface per Horse-power.** — It is a general practice among builders to furnish about 10 square feet of heating-surface per horse-power, but as the practice is not uniform, bids and contracts should always specify the amount of heating-surface to be furnished. Not less than one-third square foot of grate-surface should be furnished per horse-power with ordinary chimney draught, not exceeding 0.3 in. of water column at the damper, for anthracite coal, and for poor varieties of soft coal high in ash, with ordinary furnaces. A smaller ratio of grate surface may be allowed for high grade soft coal and for forced draught.

**Horse-power of Marine and Locomotive Boilers.** — The term horse-power is not generally used in connection with boilers in marine practice, or with locomotives. The boilers are designed to suit the engines, and are rated by extent of grate and heating-surface only.

**Grate-surface.** — The amount of grate-surface required per horse-power, and the proper ratio of heating-surface to grate-surface are extremely variable, depending chiefly upon the character of the coal and upon the rate of draught. With good coal, low in ash, approximately equal results may be obtained with large grate-surface and light draught and with small grate-surface and strong draught, the total amount of coal burned per hour being the same in both cases. With good bituminous coal, like Pittsburgh, low in ash, the best results apparently are obtained with strong draught and high rates of combustion, provided the grate-surfaces are cut down so that the total coal burned per hour is not too great for the capacity of the heating-surface to absorb the heat produced.

With coals high in ash, especially if the ash is easily fusible, tending to choke the grates, large grate-surface and a slow rate of combustion are required, unless means, such as shaking grates, are provided to get rid of the ash as fast as it is made. The amount of grate-surface required per horse-power under various conditions may be estimated as follows:

	Lbs. Water from and at 212° per lb., Coal.	Lbs. Coal per H.P. per hour.	Pounds of Coal burned per square foot of Grate per hour.									
			8	10	12	15	20	25	30	35	40	
			Sq. Ft. Grate per H.P.									
Good coal and boiler,	10	3.45	.43	.35	.28	.23	.17	.14	.11	.10	.09	
			.48	.38	.32	.25	.19	.15	.13	.11	.10	
Fair coal or boiler,	8.61	4.	.50	.40	.33	.26	.20	.16	.13	.12	.10	
			.54	.43	.36	.29	.22	.17	.14	.13	.11	
			.62	.49	.41	.33	.24	.20	.17	.14	.12	
Poor coal or boiler,	6.9	5.	.63	.50	.42	.34	.25	.20	.17	.15	.13	
			.72	.58	.48	.38	.29	.23	.19	.17	.14	
			.86	.69	.58	.46	.35	.28	.23	.22	.17	
Lignite and poor boiler,	3.45	10.	1.25	1.00	.83	.67	.50	.40	.33	.29	.25	

In designing a boiler for a given set of conditions, the grate-surface should be made as liberal as possible, say sufficient for a rate of combustion of 10 lbs. per square foot of grate for anthracite, and 15 lbs. per square foot for bituminous coal, and in practice a portion of the grate-surface may be bricked over if it is found that the draught, fuel, or other conditions render it advisable.

**Proportions of Areas of Flues and other Gas-passages.** — Rules are usually given making the area of gas-passages bear a certain ratio to the area of the grate-surface; thus a common rule for horizontal tubular boilers is to make the area over the bridge wall  $\frac{1}{7}$  of the grate-surface, the flue area  $\frac{1}{8}$ , and the chimney area  $\frac{1}{9}$ .

For average conditions with anthracite coal and moderate draught, say a rate of combustion of 12 lbs. coal per square foot of grate per hour, and a ratio of heating to grate surface of 30 to 1, this rule is as good as any, but it is evident that if the draught were increased so as to cause a rate of combustion of 24 lbs., requiring the grate-surface to be cut down to a ratio of 60 to 1, the areas of gas-passages should not be reduced in proportion. The amount of coal burned per hour being the same under the changed conditions, and there being no reason why the gases should travel at a higher velocity, the actual areas of the passages should remain as before, but the ratio of the area to the grate-surface would in that case be doubled.

Mr. Barrus states that the highest efficiency with anthracite coal is obtained when the tube area is  $\frac{1}{9}$  to  $\frac{1}{10}$  of the grate-surface, and with bituminous coal when it is  $\frac{1}{8}$  to  $\frac{1}{7}$ , for the conditions of medium rates of combustion, such as 10 to 12 lbs. per square foot of grate per hour, and 12 square feet of heating-surface allowed to the horse-power.

The tube area should be made large enough not to choke the draught and so lessen the capacity of the boiler; if made too large the gases are apt to select the passages of least resistance and escape from them at a high velocity and high temperature.

This condition is very commonly found in horizontal tubular boilers where the gases go chiefly through the upper rows of tubes; sometimes also in vertical tubular boilers, where the gases are apt to pass most rapidly through the tubes nearest to the center. It may to some extent be remedied by placing retarders in those tubes in which the gases travel the quickest.

**Air-passages through Grate-bars.** — The usual practice is, air-opening = 30% to 50% of area of the grate; the larger the better, to avoid stoppage of the air-supply by clinker; but with coal free from clinker much smaller air-space may be used without detriment. See paper by F. A. Scheffer, *Trans. A. S. M. E.*, vol. xv, p. 503.

**Distance from Dead Plate to Shell in Horizontal Tubular Boiler Settings.**—Rules of the Department of Smoke Inspection, Chicago, 1912.

Diameter of shell, in. . . .	72	66	60	54	48	42	36
Dead plate to shell, in. . .	42	40	38	36	34	32	30

The department has required that all boilers be set higher than has formerly been the practice in order to provide greater combustion space and to allow the installation of proper furnaces.

### PERFORMANCE OF BOILERS.

The performance of a steam-boiler comprises both its capacity for generating steam and its economy of fuel. Capacity depends upon size, both of grate-surface and of heating-surface, upon the kind of coal burned, upon the draught, and also upon the economy. Economy of fuel depends upon the completeness with which the coal is burned in the furnace, on the proper regulation of the air-supply to the amount of coal burned, and upon the thoroughness with which the boiler absorbs the heat generated in the furnace. The absorption of heat depends on the extent of heating-surface in relation to the amount of coal burned or of water evaporated, upon the arrangement of the gas-passages, and upon the cleanness of the surfaces. The capacity of a boiler may increase with increase of economy when this is due to more thorough combustion of the coal or to better regulation of the air-supply, or it may increase at the expense of economy when the increased capacity is due to overdriving, causing an increased loss of heat in the chimney gases. The relation of capacity to economy is therefore a complex one, depending on many variable conditions.



A formula expressing the relation between capacity, rate of driving, or evaporation per square foot of heating-surface, to the economy, or evaporation per pound of combustible is given on page 893.

Selecting the highest results obtained at different rates of driving with anthracite coal in the Centennial tests (in 1876) and the highest results with anthracite reported by Mr. Barrus in his book on Boiler Tests, the author has plotted two curves showing the maximum results which may be expected with anthracite coal, the first under exceptional conditions such as obtained in the Centennial tests, and the second under the best conditions of ordinary practice. (*Trans. A. S. M. E.*, xviii, 354). From these curves the following figures are obtained.

Lbs. water evaporated from and at 212° per sq. ft. heating-surface per hour:

1.6 1.7 2 2.6 3 3.5 4 4.5 5 6 7 8

Lbs. water evaporated from and at 212° per lb. combustible:

Centennial...	11.8	11.9	12.0	12.1	12.05	12	11.85	11.7	11.5	10.85	9.8	8.5
Barrus.....	11.4	11.5	11.55	11.6	11.6	11.5	11.2	10.9	10.6	9.9	9.2	8.5
Avg. Cent'l..	...	...	12.0	11.6	11.2	10.8	10.4	10.0	9.6	8.8	8.0	7.2

The figures in the last line are taken from a straight line drawn as nearly as possible through the average of the plotting of all the Centennial tests. The poorest results are far below these figures. It is evident that no formula can be constructed that will express the relation of economy to rate of driving as well as do the three lines of figures given above.

For semi-bituminous and bituminous coals the relation of economy to the rate of driving no doubt follows the same general law that it does with anthracite, i. e., that beyond a rate of evaporation of 3 or 4 lbs. per sq. ft. of heating-surface per hour there is a decrease of economy, but the figures obtained in different tests will show a wider range between maximum and average results on account of the fact that it is more difficult with bituminous than with anthracite coal to secure complete combustion in the furnace.

The amount of the decrease in economy due to driving at rates exceeding 4 lbs. of water evaporated per square foot of heating-surface per hour differs greatly with different boilers, and with the same boiler it may differ with different settings and with different coal. The arrangement and size of the gas-passages seem to have an important effect upon the relation of economy to rate of driving.

A comparison of results obtained from different types of boilers leads to the general conclusion that the economy with which different types of boilers operate depends much more upon their proportions and the conditions under which they work, than upon their type; and, moreover, that when the proportions are correct, and when the conditions are favorable, the various types of boilers give substantially the same economic result.

**Conditions of Fuel Economy in Steam-boilers.**—1. That the boiler has sufficient heating surface to absorb from 75 to 80% of all the heat generated by the fuel. 2. That this surface is so placed, and the gas passages so controlled by baffles, that the hot gases are forced to pass uniformly over the surface, not being short-circuited. 3. That the furnace is of such a kind, and operated in such a manner, that the fuel is completely burned in it, and that no unburned gases reach the heating surface of the boiler. 4. That the fuel is burned with the minimum supply of air required to insure complete combustion, thereby avoiding the carrying of an excessive quantity of heated air out of the chimney.

There are two indices of high economy. 1. High temperature, approaching 3000° F. in the furnace, combined with low temperature, below 600° F., in the flue. 2. Analysis of the flue gases showing between 4 and 8% of free oxygen. Unfortunately neither of these indices is available to the ordinary fireman; he cannot distinguish by the eye any temperature above 2000°, and he cannot know whether or not an excessive amount of oxygen is passing through the fuel. The ordinary haphazard way of firing therefore gives an average of about 10% lower economy than can be obtained when the firing is controlled, as it is in many large plants, by recording furnace pyrometers, or by continuous gas analysis, or by both. Low CO<sub>2</sub> in the flue gases may indicate either excessive air supply in the furnace, or leaks of air into the setting, or deficient air supply with the presence of CO, and therefore imperfect combustion. The latter, if exces-

sive, is indicated by low furnace temperature. The analysis for CO<sub>2</sub> should be made both of the gas sampled just beyond the furnace and of the gas sampled at the flue. Diminished CO<sub>2</sub> in the latter indicates air-leakage.

Less than 4% of free oxygen in the gases is usually accompanied with CO, and it therefore indicates imperfect combustion from deficient air supply. More than 8% means excessive air supply and corresponding waste of heat.

**Air Leakage** or infiltration of air through the firebrick setting is a common cause of poor economy. It may be detected by analysis as above stated, and should be prevented by stopping all visible cracks in the brick-work, and by covering it with a coating impervious to air.

**Autographic CO<sub>2</sub> Recorders** are used in many large boiler plants for the continuous recording of the percentage of carbon dioxide in the gases. When the percentage of CO<sub>2</sub> is between 12 and 16, it indicates good furnace conditions, when below 12 the reverse.

**Continuous Records** are an important element in securing maximum economy in modern boiler plants. They include records of coal and water consumption, of draft at the furnace and the chimney, of the analyses of the gases, of the flue temperature, and of the steam delivered. For description of steam flow meters and other recording apparatus see *Steam Boiler Economy*, 2d edition.

**Efficiency of a Steam-boiler.**—The efficiency of a boiler is the percentage of the total heat generated by the combustion of the fuel which is utilized in heating the water and in raising steam. With anthracite coal the heating-value of the combustible portion is very nearly 14,800 B.T.U. per lb., equal to an evaporation from and at 212° of 14,800 ÷ 970 = 15.26 lbs. of water. A boiler which when tested with anthracite coal shows an evaporation of 12 lbs. of water per lb. of combustible, has an efficiency of 12 ÷ 15.26 = 78.6%, a figure which is approximated, but scarcely ever quite reached, in the best practice. With bituminous coal it is necessary to have a determination of its heating-power made by a coal calorimeter before the efficiency of the boiler using it can be determined, but a close estimate may be made from the chemical analysis of the coal. (See Coal.)

The difference between the efficiency obtained by test and 100% is the sum of the numerous wastes of heat, the chief of which is the necessary loss due to the temperature of the chimney-gases. If we have an analysis and a calorimetric determination of the heating-power of the coal (properly sampled), and an average analysis of the chimney-gases, the amounts of the several losses may be determined with approximate accuracy by the method described below.

Data given:

1. ANALYSIS OF THE COAL.		2. ANALYSIS OF THE DRY CHIMNEY-GASES, BY WEIGHT.			
Cumberland Semi-bituminous.					
Carbon	80.55		C.	O.	N.
Hydrogen	4.50	CO <sub>2</sub> = 13.6	= 3.71	9.89	.....
Oxygen	2.70	CO = 0.2	= 0.09	0.11	.....
Nitrogen	1.08	O = 11.2	= ....	11.20	.....
Moisture	2.92	N = 75.0	= ....	.....	75.00
Ash	8.25				
	100.00	100.0	3.80	21.20	75.00

Heating-value of the coal by Dulong's formula, 14,243 heat-units.

The gases being collected over water, the moisture in them is not determined.

3. Ash and refuse as determined by boiler-test, 10.25, or 2% more than that found by analysis, the difference representing carbon in the ashes obtained in the boiler-test.

4. Temperature of external atmosphere, 60° F.

5. Relative humidity of air, 60%, corresponding (see air tables) to 0.007 lb. of vapor in each lb. of air.

6. Temperature of chimney-gases, 560° F.

Calculated results:

The carbon in the chimney-gases being 3.8% of their weight, the total weight of dry gases per lb. of carbon burned is 100 ÷ 3.8 = 26.32 lbs. Since the carbon burned is 80.55 - 2 = 78.55% of the weight of the coal, the weight of the dry gases per lb. of coal is 26.32 × 78.55 ÷ 100 = 20.67 lbs.

Each pound of coal furnishes to the dry chimney-gases 0.7855 lb. C, 0.0108 N, and  $(2.70 - \frac{4.50}{8}) \div 100 = 0.0214$  lb. O; a total of 0.8177, say 0.82 lb. This subtracted from 20.67 lbs. leaves 19.85 lbs. as the quantity of dry air (not including moisture) which enters the furnace per pound of coal, not counting the air required to burn the available hydrogen, that is, the hydrogen minus one-eighth of the oxygen chemically combined in the coal. Each lb. of coal burned contained 0.045 lb. H, which requires  $0.045 \times 8 = 0.36$  lb. O for its combustion. Of this, 0.027 lb. is furnished by the coal itself, leaving 0.333 lb. to come from the air. The quantity of air needed to supply this oxygen (air containing 23% by weight of oxygen) is  $0.333 \div 0.23 = 1.45$  lb., which added to the 19.85 lbs. already found gives 21.30 lbs. as the quantity of dry air supplied to the furnace per lb. of coal burned.

The air carried in as vapor is 0.0071 lb. for each lb. of dry air, or  $21.3 \times 0.0071 = 0.15$  lb. for each lb. of coal. Each lb. of coal contained 0.029 lb. of moisture, which was evaporated and carried into the chimney-gases. The 0.045 lb. of H per lb. of coal when burned formed  $0.045 \times 9 = 0.405$  lb. of  $H_2O$ .

From the analysis of the chimney-gas it appears that  $0.09 \div 3.80 = 2.37\%$  of the carbon in the coal was burned to CO instead of to  $CO_2$ .

We now have the data for calculating the various losses of heat, as follows, for each pound of coal burned:

	Heat-units.	Per cent of Heat-value of the Coal.
20.67 lbs. dry gas $\times (560^\circ - 60^\circ) \times$ sp. heat 0.24 =	2480.4	17.41
0.15 lb. vapor in air $\times (560^\circ - 60^\circ) \times$ sp. ht. 0.48 =	36.0	0.25
0.029 lb. moist. in coal heated from $60^\circ$ to $212^\circ$ =	4.4	0.03
0.029 lb. evap. from and at $212^\circ$ ; $0.029 \times 966$ =	28.0	0.20
0.029 lb. steam (heated $212^\circ$ to $560^\circ$ ) $\times 348 \times 0.48$ =	4.8	0.03
0.405 lb. $H_2O$ from H in coal $\times (152 + 966 + 348 \times 0.48)$ =	520.4	3.65
0.0237 lb. C burned to CO; loss by incomplete combustion, $0.0237 \times (14544 - 4451)$ =	239.2	1.68
0.02 lb. coal lost in ashes; $0.02 \times 14544$ =	290.9	2.04
Radiation and unaccounted for, by difference =	624.0	4.38
	<hr/> 4228.1	<hr/> 29.69
Utilized in making steam, equivalent evaporation 10.37 lbs. from and at $212^\circ$ per lb. of coal =	10,014.9	70.31
	<hr/> 14,243.0	<hr/> 100.00

The heat lost by radiation from the boiler and furnace is not easily determined directly, especially if the boiler is enclosed in brickwork, or is protected by non-conducting covering. It is customary to estimate the heat lost by radiation by difference, that is, to charge radiation with all the heat lost which is not otherwise accounted for. One method of determining the loss by radiation is to block off a portion of the grate-surface and build a small fire on the remainder, and drive this fire with just enough draught to keep up the steam-pressure and supply the heat lost by radiation without allowing any steam to be discharged, weighing the coal consumed for this purpose during a test of several hours' duration.

Estimates of radiation by difference are apt to be greatly in error, as in this difference are accumulated all the errors of the analyses of the coal and of the gases. An average value of the heat lost by radiation from a boiler set in brickwork is about 3%. When several boilers are in a battery and enclosed in a boiler-house the loss by radiation may be very much less, since much of the heat radiated from the boiler is returned to it in the air supplied to the furnace, which is taken from the boiler-room.

An important source of error in making a "heat balance" such as the one above given, especially when highly bituminous coal is used, may be due to the non-combustion of part of the hydrocarbon gases distilled from the coal immediately after firing, when the temperature of the furnace may be reduced below the point of ignition of the gases. Each pound of hydrogen which escapes burning is equivalent to a loss of heat in the furnace of



62,000 heat-units. Another source of error, especially with bituminous slack coal high in moisture, is due to the formation of water-gas,  $\text{CO} + \text{H}$ , by the decomposition of the water, and the consequent absorption of heat, this water-gas escaping unburned on account of the choking of the air supply when fine fresh coal is supplied to the fire.

In analyzing the chimney-gases by the usual method the percentages of the constituent gases are obtained by volume instead of by weight. To reduce percentages by volume to percentages by weight, multiply the percentage by volume of each gas by its specific gravity as compared with air, and divide each product by the sum of the products.

Instead of using the percentages by weight of the gases, the percentage by volume may be used directly to find the weight of gas per pound of carbon by the formula given below.

If  $\text{O}$ ,  $\text{CO}$ ,  $\text{CO}_2$ , and  $\text{N}$  represent the percentages by volume of oxygen, carbonic oxide, carbonic acid, and nitrogen, respectively, in the gases of combustion:

$$\left. \begin{array}{l} \text{Lb. of air required to burn} \\ \text{one pound of carbon} \end{array} \right\} = \frac{3.032 \text{ N}}{\text{CO}_2 + \text{CO}}$$

$$\text{Ratio of total air to the theoretical requirement} = \frac{\text{N}}{\text{N} - 3.782 (\text{O} - 1/2 \text{CO})}$$

$$\left. \begin{array}{l} \text{Lb. of air per pound} \\ \text{of coal} \end{array} \right\} = \left\{ \begin{array}{l} \text{Lb. of air per pound} \\ \text{of carbon} \end{array} \right\} \times \left\{ \begin{array}{l} \text{Per cent of car-} \\ \text{bon in coal} \end{array} \right\}$$

$$\text{Lb. dry gas produced per pound of carbon} = \frac{11 \text{ CO}_2 + 8 \text{ O} + 7 (\text{CO} + \text{N})}{3 (\text{CO}_2 + \text{CO})}$$

**Relation of Boiler Efficiency to the Rate of Driving, Air Supply, etc.**—In the author's Steam Boiler Economy (p. 294) a formula is developed showing the efficiency that may be expected, when the combustion of the coal is complete, under different conditions. The formula is

$$\frac{E_a}{E_p} = \frac{K - tcf}{K (1 + RS/W)} - \frac{970}{K} \frac{ac^2f^2}{(K - tcf)} \frac{W}{S}$$

$K$  = heating value per lb. of combustible;  $E_a$  = actual evaporation from and at  $212^\circ$  per lb. of combustible;  $E_p$  = possible evaporation =  $K \div 970$ ;  $t$  = elevation of the temperature of the water in the boiler above the atmospheric temperature;  $c$  = specific heat of the chimney gases, taken at 0.24;  $f$  = weight of flue gases per lb. of combustible;  $S$  = square feet of heating surface;  $W$  = pounds of water evaporated per hour;  $W/S$  = rate of driving;  $R$  = radiation loss, in units of evaporation per sq. ft. of heating-surface per hour;  $a$  is a coefficient found by experiment; it may be called a coefficient of inefficiency of the boiler, and it depends on and increases with the resistance to the passage of heat through the metal, soot or scale on the metal, imperfect combustion, short-circuiting, air leakage, or any other defective condition, not expressed in terms in the formula, which may tend to lower the efficiency. Its value is between 200 and 400 when records of tests show high efficiency, and above 400 for lower efficiencies.

The coefficient  $a$  is a criterion of performance of a boiler when all the other terms of the formula are known as the results of a test. By transposition its value is

$$a = \left[ \frac{K - tcf}{970 (1 + RS/W)} - E_a \right] \div \frac{c^2f^2}{(K - tcf)} \frac{W}{S}$$

On the diagram below (Fig. 159), with abscissas representing rates of driving and ordinates representing efficiencies are plotted curves showing the relation of the efficiency to rate of driving for values of  $a = 100$  to 400 and values of  $f$  from 20 to 35, together with a broken line showing the maximum efficiencies obtained by six boilers at the Centennial Exhibition, and other lines showing the poor results obtained from five other boilers. The curves are also based on the following values,  $K = 14,800$ ;  $c = 0.24$ ;  $t = 300$  (except one curve,  $t = 250$ );  $R = 0.1$ .

An inspection of the curves shows the following. 1. The maximum Centennial results all lie below the curve  $f = 20$ ,  $a = 200$ , by 2 to 4%, but they follow the general direction of the curve. This curve may

therefore be taken as representing the maximum possible boiler performance with anthracite coal, as the results obtained in 1876 have never been exceeded with anthracite.

2. With  $f = 20$  and  $a = 200$  the efficiency for maximum performance, according to the curve, is a little less than 82% at 2 lbs. evaporation per sq. ft. of heating-surface per hour, but it decreases very slowly at higher rates, so that it is 80% at  $3\frac{1}{2}$  lbs., and 76% at  $5\frac{3}{4}$  lbs.

With  $a = 200$  and  $f$  greater than 20, the efficiency has a lower maximum, reaches the maximum at a lower rate of driving, and falls off rapidly as the rate increases, the more rapidly the higher the value of  $f$ , showing excessive air supply to be a potent cause of low economy.

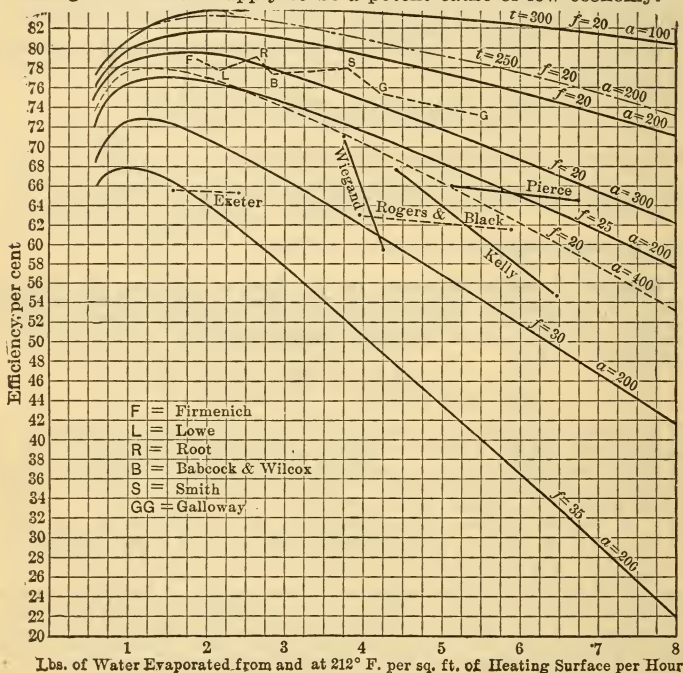

FIG. 159.

3. An increase in the value of  $a$  from 200 to 400 with  $f = 20$  is much less detrimental to efficiency than an increase in  $f$  from 20 to 30.

In the diagram, Fig. 160, are plotted, together with the curve for  $f = 20$ ,  $a = 200$ ,  $t = 300$ , and  $K = 15,750$ , marked  $R = 0.1$ , a straight line,  $R = 0$ , showing the theoretical maximum efficiency when there is no loss by radiation, and the plottings of the results of two series of tests, one of a Thornycroft boiler, with  $W/S$  from 1.24 to 8.5, and the other of a Babcock & Wilcox marine boiler with  $W/S$  from 5.18 to 13.67, together with the maximum Centennial tests. The calculated value of  $a$  in all these tests except one ranged from 191 to 454, the highest values being those showing the largest departure from the curve  $R = 0.1$ . The one exception is the Thornycroft test showing over 86% efficiency; this gives a value of  $a = 57$ , which indicates an error in the test, as such a low value is far below the lowest recorded in any other test.

In the second edition of Steam Boiler Economy (page 316), there is developed a modification of the efficiency formula, so that it takes

account, in addition to the other variables, of hydrogen and moisture in the coal and of incomplete combustion. It is

$$\frac{E_a}{E_p} = \frac{K_1 - tcf_1}{K + (1RS/W)} - \frac{970.4}{K} \frac{a_1 c^2 f_1^2}{K (K_1 - tcf_1)} \frac{W}{S}$$

The notation is the same as in the original formula except that  $K_1 = K - 101.5 C \frac{CO}{CO + CO_2} - 970.4 (0.09 H + 0.01 M)$  in which C, H and M are respectively the percentages of carbon, hydrogen and moisture in the coal, and CO and CO<sub>2</sub> percentages by volume of the dry flue gases, and  $f_1 = f + 0.28H + 0.03 M$ .

Computing the results of six series of boiler tests, 47 tests in all, which have given high efficiencies, the value of  $a_1$  is found to average about 200. Values from 160 to 240 may be obtained in duplicate tests

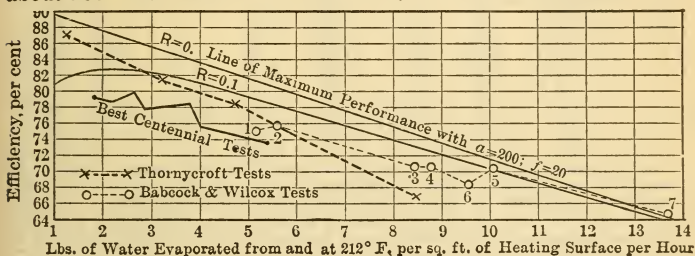

FIG. 160.

in which all the conditions, as far as known, are identical, the difference between individual and average values being probably due to errors. Values above 300, if not due to errors, represent defective performance which may be due to short-circuiting or to unclean heating surfaces.

**Effect of Quality of Coal upon Efficiency.**—Calculations have been made, using the formula given above, of the theoretical efficiencies obtainable from five different kinds of coal and an average fuel oil, the analyses of which are given below, on the assumption of complete combustion with 20% excess air supply,  $a_1 = 200$ ,  $t = 300$ ,  $c = 0.24$  and rates of driving  $W/S$  from 1 to 14 lb. The results are shown in the table.

ANALYSES OF FUELS.

Anthracite Dry and Free from Ash.	Semi-bitum.	Pittsburgh Ash and Sul. Free.	Illinois	Lignite.	California Fuel Oil.
C 94.3	Moist. 1.7	Moist. 2.0	Moist. 10.8	Moist. 27.0	0.2
H 2.3	N.S. Ash 4.6	C 83.0	C 61.0	C 47.4	84.9
O 2.4	C 85.0	H 5.5	H 4.2	H 3.3	11.9
N 1.0	H 4.5	O 8.0	O 9.6	O 12.0	1.9
	O 3.2	N 1.0	N 1.2	N 1.0	S 1.1
			Ash, S 13.2		
B.T.U. per lb. 15,000	14,950	14,908	10,640	8,250	19,600

RELATION OF EFFICIENCY TO QUALITY OF COAL.

Rate of Driving, W/S.	1	2	3	4	6	8	10	12	14
	Efficiencies								
Anthracite.....	81.85	84.56	84.71	84.16	82.39	80.25	77.95	75.59	73.19
Semi-bitum.....	80.41	82.96	83.00	82.38	80.42	78.10	75.64	73.12	70.54
Pittsburgh bitum..	79.78	82.30	82.34	81.71	79.76	77.45	75.01	72.48	69.92
Illinois.....	78.28	80.59	80.44	79.64	77.34	74.71	71.93	69.09	66.20
Lignite.....	75.83	77.76	77.51	76.52	73.98	70.90	67.79	64.62	61.40
Fuel Oil.....	78.78	81.61	82.01	81.74	80.52	78.97	77.26	75.48	73.58



**Effect of Imperfect Combustion and Excess Air Supply.**—Taking a Pittsburgh bituminous coal, having a composition, free from sulphur and ash, of 83 C, 5.5 H, 8 O, 1.5 N, and 2 Moisture, and a heating value of 14,908 B.T.U. per lb. fuel = 15,222 B.T.U. per lb. combustible, and assuming it to be burned with different quantities of air, as in the table below, we may compute the weight of air supplied per pound of fuel and per pound of carbon, and the analysis by volume of the gases, giving results as follows:

Case.	Per Cent of C Burned to CO <sub>2</sub> .	Per Cent Excess Air.	Dry Gas per lb. Fuel = <i>f</i> .	Dry Gas per lb. Carbon.	Analysis of Dry Gas by Volume.			
					CO <sub>2</sub> .	CO.	O.	N.
(1).....	0	0	11.60	13.98	18.45	0	0	81.55
(2).....	0	20	13.83	16.66	15.30	0	3.56	81.14
(3).....	0	50	17.16	20.67	12.18	0	7.09	80.73
(4).....	0	100	22.72	27.37	9.10	0	10.57	80.33
A.....	5	0	11.36	13.69	17.85	0.94	0	81.21
B.....	5	20	13.23	15.93	15.18	0.80	3.12	80.90
C.....	10	0	11.12	13.40	17.21	1.92	0	80.87
D.....	20	0	10.65	12.83	15.88	3.97	0	80.15

H<sub>2</sub>O in gases per lb. fuel = 0.09 H + 0.01 M, in all cases = 0.515 lb. Case (1) is an ideal but not a practicable case, since it is not possible in practice to burn all the C to CO<sub>2</sub> without excess of air. Cases (2), (3), (4), A and B are all within the range of ordinary practice (which sometimes shows 200% or more excess air) and cases C and D represent either the condition of too heavy firing and choked air supply, or the condition existing for a minute or two after firing of fine moist slack coal, which temporarily chokes the air supply and causes the formation of a great volume of smoky gas.

Cases 2 and A represent the best possible practice, reached only when all conditions are most favorable.

Applying the formula given above, we take  $K = 14,908$ ;  $t = 300$ ;  $c = 0.24$ ;  $R = 0.1$ ;  $a_1 = 200$ ;  $f =$  the values given in the table;  $K_1$  and  $f_1 =$  values given by the formulæ in the preceding paragraph, and  $W/S$  different values from 0.5 to 14, and obtain the theoretical efficiencies given below:

THEORETICAL EFFICIENCIES WITH PITTSBURGH COAL UNDER DIFFERENT CONDITIONS.

Case.....	(1)	(2)	(3)	(4)	A	B	C	D
Per cent C to CO <sub>2</sub> .....	0	0	0	0	5	5	10	20
Per cent excess air.....	0	20	50	100	0	20	0	0
$W/S =$	Efficiencies, Per Cent.							
0.5	74.76	73.68	72.05	68.97	72.53	71.61	69.77	65.79
1	81.13	79.78	77.73	73.72	78.69	77.54	76.23	71.34
2	84.06	82.30	79.60	73.90	81.53	80.02	78.98	73.87
3	84.49	82.34	79.02	71.72	81.91	80.09	79.35	74.16
4	84.24	81.71	77.79	68.91	81.64	79.50	79.09	73.85
6	83.03	79.76	74.65	62.60	80.43	77.65	77.91	72.64
8	81.47	77.45	71.17	55.87	78.87	75.48	76.39	71.11
10	79.77	75.01	67.55	49.20	77.17	73.15	74.74	69.45
12	77.99	72.48	63.86	42.37	75.41	70.76	73.02	67.72
14	76.16	69.92	60.12	35.48	73.58	68.32	71.27	65.97

The figures in the table show the great falling off in efficiency at high rates of driving when the air supply is excessive, and the necessity of gas analysis (or of a CO<sub>2</sub> or an oxygen indicator) if high efficiencies are to be obtained at high rates of driving.

**The Straight-line Formula for Efficiency.**—An examination of the curves plotted from the table given above shows that when the rate of driving is in excess of 3 lb. per sq. ft. of heating surface per hour, and the effect of the radiation loss is therefore of small importance, the curves become approximately straight lines, the formula of which is

$E = E_{max} - C(W/S - 3)$ , in which  $E$  is the efficiency at any rate of driving above  $W/S = 3$ ,  $E_{max}$  is the efficiency when  $W/S = 3$ , and  $C$  is a constant which depends on the quality of the coal and on the furnace conditions. Taking from the above table the efficiencies at  $W/S = 3$  and  $W/S = 14$  and calculating the value of  $C$  in the above equation of a straight line between these points, we obtain the following formulæ for efficiency for the several cases named:

Cases.	Per Cent C to CO <sub>2</sub>	Per Cent Excess Air.	Formula.
1	0	0	$E = 84.5 - 0.76(W/S - 3)$
2	0	20	$E = 82.3 - 1.13(W/S - 3)$
3	0	50	$E = 79.0 - 1.72(W/S - 3)$
4	0	100	$E = 71.7 - 3.39(W/S - 3)$
A	5	0	$E = 81.9 - 0.76(W/S - 3)$
B	5	20	$E = 80.1 - 1.07(W/S - 3)$
C	10	0	$E = 79.4 - 0.74(W/S - 3)$
D	20	0	$E = 74.2 - 0.75(W/S - 3)$

The efficiencies calculated by these formulæ in every case in which  $W/S$  is between 3 and 14 are slightly lower than those calculated from the complex formula, but in no case is the difference as great as 1%. It must be noted that all the efficiencies are theoretical ones, based on the assumptions that there are no leaks of air into the boiler setting, no loss due to unburned hydrocarbons, and no short circuiting or deposit of soot on the tubes. In cases 1, A, C and D, in which there is no excess air supply, there would in practice be probably some loss from unburned hydrocarbons.

The straight line formulæ obtained from the figures in the table showing the relation of quality of coal to efficiency, assuming complete combustion and 20% excess air supply, are

Anthracite.....	$E = 84.7 - 1.05(W/S - 3)$
Semi-bituminous.....	$E = 83.0 - 1.13(W/S - 3)$
Pittsburgh bituminous.....	$E = 82.3 - 1.13(W/S - 3)$
Illinois bituminous.....	$E = 80.4 - 1.29(W/S - 3)$
Lignite.....	$E = 77.5 - 1.46(W/S - 3)$
Fuel oil.....	$E = 82.0 - 0.77(W/S - 3)$

**Efficiencies Obtained in Practice.**—In the best modern practice, under the most favorable furnace conditions, the highest figures in the above tables have almost been reached. A few tests with fuel oil have shown figures slightly higher than those given above. The best record yet obtained with coal is that of the ten best out of the sixteen tests at the Delray station of the Detroit Edison Co., reported by D. S. Jacobus in *Trans. A. S. M. E.*, 1911. A straight line drawn through the plotting of these tests corresponds to the formula

$$E = 81 - 1.33(W/S - 3).$$

No account is taken in the above calculation of any loss due to unconsumed hydrogen or hydrocarbons, nor of absorption of heat by decomposition of moisture in the coal by the reaction  $C + H_2O = 2H + CO$ . Serious losses may be due to these causes if the air supply is deficient and the furnace temperature low from the firing of a thick layer of fresh and moist coal, or if the combustible gases are chilled by the surface of the boiler to a temperature below that of ignition. No account, either, has been taken of the loss due to moisture in the air, which loss is usually not over 0.5%, but may reach 2% with excessive air supply of high temperature and humidity.

The highest efficiencies are obtained with low rates of driving, say 3 to 4 lb. evaporated from and at 212° per sq. ft. of heating surface per hour. With higher rates of driving high efficiencies can be obtained only when the air supply is carefully regulated according to the indications of gas analyses, when the coal is nearly dry, when it is fed at a regular rate by a mechanical stoker, and when the gases from the coal are completely burned in a large fire-brick combustion chamber before they are chilled by the comparatively cool surfaces of the boiler. Modern practice tends to extremely large combustion chambers.

With water-tube boilers of the Babcock & Wilcox type the tubes are often placed 12 feet or more above the grate bars. In the Stirling boilers of the Detroit Edison Co. the combustion chambers are over 25 ft. high.

The range of efficiency between the highest possible and that which may be found in ordinary practice is very large. While 80 per cent efficiency is possible with anthracite and semi-bituminous coals, and with bituminous coals containing not over 3% moisture and not over 35% volatile matter in the combustible, it is difficult to get over 65% with Illinois coals, high in volatile matter and in moisture, even with mechanical stokers and with gas analysis. With ordinary hand-firing the average efficiency is apt to be at least 15% lower than these figures. For numerous records of boiler tests under various conditions, with a discussion of the results, see "Steam Boiler Economy," 2d edition.

**Maximum Boiler Efficiencies at Different Rates of Driving.**—The ten best tests of the large boilers of the Detroit Edison Co., reported by D. S. Jacobus in *Jour. A. S. M. E.*, Nov., 1911, with rates of driving from 3.24 to 7.29 lb. water evaporated from and at 212° per sq. ft. of heating surface per hour gave efficiencies which are represented (within 1%) by the formula  $E = 81 - 1.33(R - 3)$ , in which  $E$  is the efficiency per cent and  $R$  the rate of driving. Eight tests of Babcock & Wilcox marine boilers built for the U. S. war-vessels *Cincinnati* and *Wyoming* (*Indust. Eng'g*, March, 1911), at rates of driving from 8.42 to 14.76 lb. correspond within 3% with the formula  $E = 80 - 1.43(R - 3)$ . The Detroit tests were made with bituminous coal, low in moisture, containing about 30% volatile matter, with mechanical stokers and very large combustion chambers. The marine boiler tests were made with semi-bituminous coal containing about 20% volatile matter, with hand-firing. These tests establish a world's record for boiler efficiencies. The formulæ give the following efficiencies for the several rates of driving named, the first being used for rates of driving of 3 to 7 lb. and the second for rates of 7 to 15 lb.

$R =$	3	4	5	6	7	8	10	12	14	15
$E =$	81	79.7	78.3	77.0	75.7	72.9	70.0	67.1	64.3	62.8

**Some High Rates of Evaporation.**—*Eng'g*, May 9, 1884, p. 415.

	Locomotive.		Torpedo-boat.	
Water evap. per sq. ft. H.S. per hour.	12.57	13.73	12.54	20.74
Water evap. per lb. fuel from and at 212°	8.22	8.94	8.37	7.04
Thermal units transf'd per sq. ft. of H.S.	12,142	13,263	12,113	20,034
Efficiency	0.586	0.637	0.542	0.468

It is doubtful if these figures were corrected for moisture in the steam.

### BOILERS USING WASTE GASES.

**Steam-boilers Fired with Waste Gases from Puddling and Heating-Furnaces.**—The *Iron Age*, April 6, 1893, contains a report of a number of tests of steam-boilers utilizing the waste heat from puddling and heating-furnaces in rolling-mills. The following principal data are selected: in Nos. 1, 2, and 4 the boiler is a Babcock & Wilcox water-tube boiler, and in No. 3 it is a plain cylinder boiler, 42 in. diam. and 26 ft. long. No. 4 boiler was connected with a heating-furnace, the others with puddling furnaces.

	No. 1	No. 2	No. 3	No. 4
Heating-surface, sq. ft.	1026	1196	143	1380
Grate-surface, sq. ft.	19.9	13.6	13.6	16.7
Ratio H.S. to G.S.	52	87.2	10.5	82.8
Water evap. per hour, lbs.	3358	2159	1812	3055
Water evap. per sq. ft. H.S. per hr. lbs.	3.3	1.8	12.7	2.2
Water evap. per lb. coal from and at 212°	5.9	6.24	3.76	6.34
Water evap. per lb. combustible from and at 212°		7.20	4.31	8.34

In No. 2, 1.38 lb. of iron were puddled per lb. of coal.

In No. 3, 1.14 lb. of iron were puddled per lb. of coal.

No. 3 shows that an insufficient amount of heating-surface was provided for the amount of waste heat available.



**Water-tube Boilers using Blast-furnace Gases.**—D. S. Jacobus (*Trans. A. I. M. E.*, xvii, 50) reports a test of a water-tube boiler using blast-furnace gas as fuel. The heating-surface was 2535 sq. ft. It developed 328 H.P., or 5.01 lb. of water from and at 212° per sq. ft. of heating-surface per hour. Some of the principal data obtained were as follows: Calorific value of 1 lb. of the gas, 1413 B.T.U., including the effect of its initial temperature, which was 650° F. Amount of air used to burn 1 lb. of the gas = 0.9 lb. Chimney draught, 1 1/3 in. of water. Area of gas inlet 300 sq. in.; of air inlet, 100 sq. in. Temperature of the chimney gases, 775° F. Efficiency of the boiler calculated from the temperatures and analyses of the gases at exit and entrance, 61%. The average analyses were as follows, hydrocarbons being included in the nitrogen:

	By Weight.		By Volume.	
	At Entrance.	At Exit.	At Entrance.	At Exit.
CO <sub>2</sub> .....	10.69	26.37	7.08	18.64
O.....	0.11	3.05	0.10	2.96
CO.....	26.71	1.78	27.80	1.98
Nitrogen.....	62.48	68.80	65.02	76.42
C in CO <sub>2</sub> .....	2.92	7.19	.....	.....
C in CO.....	11.45	0.76	.....	.....
Total C.....	14.37	7.95	.....	.....

**RULES FOR CONDUCTING BOILER TESTS.**

**Object of an Evaporation Test.**—The principal object of an evaporation test of a steam-boiler is to find out how many pounds of water it evaporates under a certain set of conditions in a given time and how many pounds of coal are required to effect this evaporation. The test may be made for one or more of several purposes, viz:

1. To determine whether or not the stipulations of a contract between the seller and the buyer of a boiler (or of an appendage to the boiler, such as a furnace) have been performed.
2. To determine the relative economy of different kinds of fuel, of different kinds of furnaces, or of different methods of driving.
3. To determine whether or not the boilers, as ordinarily run under the every-day conditions of the plant, are operated as economically as they should be.
4. To determine, in case the boilers either fail to furnish easily the quantity of steam desired, or else furnish it at what is supposed to be an excessive cost for fuel, whether any additional boilers are needed or whether some change in the conditions of running is a sufficient remedy for the difficulty.

For the first of the above-named purposes, it is necessary that the test should be made with every precaution to insure accuracy, such as those described in the Code of the Committee of the American Society of Mechanical Engineers,\* which is printed in abridged form below.

**INSTRUCTIONS REGARDING TESTS IN GENERAL.**

(Code of 1915).

**OBJECT.**

Ascertain the specific object of the test, and keep this in view not only in the work of preparation, but also during the progress of the test.

If questions of fulfillment of contract are involved, there should be

\* *Trans. A.S.M.E.*, 1914, Reprinted in pamphlet form by the Society. The first committee of the society on boiler-tests reported in 1885, the second in 1899. In 1909 a committee on Tests of Power Plant Apparatus was appointed; its preliminary report was published in 1912. and its final report in 1914.

a clear understanding between all the parties, preferably in writing, as to the operating conditions which should obtain during the trial, the methods of testing to be followed, corrections to be made in case the conditions actually existing during the test differ from those specified, and all other matters about which dispute may arise, unless these are already expressed in the contract itself.

#### PREPARATIONS.

*Dimensions.*—Measure the dimensions of the principal parts of the apparatus to be tested, so far as they bear on the objects in view, or determine them from working drawings. Notice the general features of the apparatus, both exterior and interior, and make sketches, if needed, to show unusual points of design.

The areas of the heating surfaces of boilers and superheaters to be found are those of surfaces in contact with the fire or hot gases. The submerged surfaces in boilers at the mean water level should be considered as water-heating surfaces, and other surfaces which are exposed to the gases as superheating surfaces.

*Examination of Plant.*—Make a thorough examination of the physical condition of all parts of the plant or apparatus which concern the object in view, and record the conditions found.

In boilers examine for leakage of tubes and riveted or other metal joints. Note the condition of brick furnaces, grates and baffles. Examine brick walls and cleaning doors for air leaks, either by shutting the damper and observing the escaping smoke or by candle-flame test. Determine the condition of heating surfaces with reference to exterior deposits of soot and interior deposits of mud or scale.

If the object of the test is to determine the highest efficiency or capacity obtainable, any physical defects, or defects of operation, tending to make the result unfavorable should first be remedied; all fouled parts being cleaned, and the whole put in first-class condition. If, on the other hand, the object is to ascertain the performance under existing conditions, no such preparation is either required or desired.

*Precautions against Leakage.*—In steam tests make sure that there is no leakage through blow-offs, drips, etc., or any steam or water connections, which would in any way affect the results. All such connections should be blanked off, or satisfactory assurance should be obtained that there is leakage neither out nor in.

*Apparatus and Instruments.*—See that the apparatus and instruments are substantially reliable, and arrange them in such a way as to obtain correct data.

*Weighing Scales.*—For determining the weight of coal, oil, water, etc., ordinary platform scales serve every purpose. Too much dependence, however, should not be placed upon their reliability without first calibrating them by the use of standard weights, and carefully examining the knife-edges, bearing plates, and ring suspensions, to see that they are all in good order.

For testing locomotives and some classes of marine boilers, where room is lacking, sacks or bags are sometimes required to facilitate the handling of coal, the sacks being weighed at the time of filling.

#### SAMPLING AND DRYING COAL.

Select a representative shovelful from each barrow-load as it is drawn from the coal-pile or other source of supply, and store the samples in a cool place in a covered metal receptacle. When all the coal has thus been sampled, break up the lumps, thoroughly mix the whole quantity, and finally reduce it by the process of repeated quartering and crushing to a sample weighing about 5 lbs., the largest pieces being about the size of a pea. From this sample two 1-qt. air-tight glass fruit-jars, or other air-tight vessels, are to be promptly filled and preserved for subsequent determinations of moisture, calorific value, and chemical composition.

When the sample lot of coal has been reduced by quartering to

say 100 lbs., a portion weighing say 15 to 20 lbs. should be withdrawn for the purpose of immediate moisture determination. This is placed in a shallow iron pan and dried on the hot iron boiler flue for at least 12 hours, being weighed before and after drying on scales reading to quarter ounces.

The moisture thus determined is approximately reliable for anthracite and semi-bituminous coals, but not for coals containing much inherent moisture. For such coals, and for all absolutely reliable determinations the method to be pursued is as follows:

Take one of the samples contained in the glass jars, and subject it to a thorough air drying, by spreading it in a thin layer and exposing it for several hours to the atmosphere of a warm room, weighing it before and after, thereby determining the quantity of surface moisture it contains. Then crush the whole of it by running it through an ordinary coffee mill or other suitable crusher adjusted so as to produce somewhat coarse grains (less than  $\frac{1}{16}$  in.), thoroughly mix the crushed sample, select from it a portion of from 10 to 50 grams (say  $\frac{1}{2}$  oz. to 2 oz.), weigh it in a balance which will easily show a variation as small as 1 part in 1000, and dry it for one hour in an air or sand bath at a temperature between 240 and 280° F. Weigh it and record the loss, then heat and weigh again until the minimum weight has been reached. The difference between the original and the minimum weight is the moisture in the air-dried coal. The sum of the moisture thus found and that of the surface moisture is the total moisture.

If a larger drying oven is available the moisture may be determined by heating one of the glass jars full of coal, the cover being removed, at a temperature between 240° and 280° F. until it reaches the minimum weight.

#### SAMPLING STEAM.

Construct a sampling pipe or nozzle made of  $\frac{1}{2}$ -in. iron pipe and insert it in the steam main at a point where the entrained moisture is likely to be most thoroughly mixed. The inner end of the pipe, which should extend nearly across to the opposite side of the main, should be closed and the interior portion perforated with not less than twenty  $\frac{1}{8}$ -in. holes equally distributed from end to end and preferably drilled in irregular or spiral rows, with the first hole not less than half an inch from the wall of the pipe.

The sampling pipe should not be placed near a point where water may pocket or where such water may affect the amount of moisture contained in the sample.

### RULES FOR CONDUCTING EVAPORATIVE TESTS OF BOILERS.

#### OBJECT AND PREPARATIONS.

Determine the object of the test, take the dimensions, note the physical conditions, examine for leakages, install the testing appliances, etc., as pointed out in the general instructions and make preparations for the test accordingly.

#### FUEL.

Determine the character of fuel to be used. For tests of maximum efficiency or capacity of the boiler to compare with other boilers, the coal should be of some kind which is commercially regarded as a standard for the locality where the test is made.

A coal selected for maximum efficiency and capacity tests should be the best of its class, and especially free from slagging and unusual clinker-forming impurities.

For guarantee and other tests with a specified coal containing not more than a certain amount of ash and moisture, the coal selected should not be higher in ash and in moisture than the stated amounts



because any increase is liable to reduce the efficiency and capacity more than the equivalent proportion of such increase.

#### OPERATING CONDITIONS.

Determine what the operating conditions and method of firing should be to conform to the object in view, and see that they prevail throughout the trial, as nearly as possible.

#### DURATION.

The duration of tests to determine the efficiency of a hand-fired boiler should be at least ten consecutive hours. In case the rate of combustion is less than 25 lbs. per sq. ft. of grate per hour the tests should be continued for such a time as may be required to burn a total of 250 lbs. of coal per square foot of grate. Tests of longer duration than 10 hours are advisable in order to obtain greater accuracy.

In the case of a boiler using a mechanical stoker, the duration, where practicable, should be at least 24 hours. If the stoker is of a type that permits the quantity and condition of the fuel bed at beginning and end of the test to be accurately estimated, the duration may be reduced to 10 hours, or such time as may be required to burn the total of 250 lbs. per square foot.

#### STARTING AND STOPPING.

The conditions regarding the temperature of the furnace and boiler, the quantity and quality of the live coal and ash on the grates, the water level, and the steam pressure, should be as nearly as possible the same at the end as at the beginning of the test.

To secure the desired equality of conditions with hand-fired boilers, the following method should be employed:

The furnace being well heated by a preliminary run, burn the fire low, and thoroughly clean it, leaving enough live coal spread evenly over the grate (say 2 to 4 ins.),\* to serve as a foundation for the new fire. Note quickly the thickness of the coal bed as nearly as it can be estimated or measured, also the water level,† the steam pressure, and the time, and record the latter as the starting time. Fresh coal should then be fired from that weighed for the test, the ash-pit thoroughly cleaned and the regular work of the test proceeded with.

Before the end of the test the fire should again be burned low and cleaned in such a manner as to leave the same amount of live coal on the grate as at the start. When this condition is reached, observe quickly the water level,† the steam pressure, and the time, and record the latter as the stopping time. If the water level is lower than at the beginning, a correction should be made by computation, rather than by feeding additional water. Finally remove the ashes and refuse from the ashpit.

In a plant containing several boilers where it is not practicable to clean them simultaneously, the fires should be cleaned one after the other as rapidly as may be, and each one after cleaning charged with enough coal to maintain a thin fire in good working condition. After the last fire is cleaned and in working condition, burn all the fires low (say 4 to 6 ins.), note quickly the thickness of each, also the water levels, steam pressure, and time, which last is taken as the starting time. Likewise when the time arrives for closing the test, the fires should be quickly cleaned one by one, and when this work is completed they should all be burned low the same as at the start and the various observations made as noted.

---

\* 1 to 2 ins. for small anthracite coals.

† Do not blow down the water-glass column for at least one hour before these readings are taken. An erroneous indication may otherwise be caused by a change of temperature and density of the water within the column and connecting pipe.

In the case of a large boiler having several furnace doors requiring the fire to be cleaned in sections one after the other, the above directions pertaining to starting and stopping in a plant of several boilers may be followed.

To obtain the desired equality of conditions of the fire when a mechanical stoker other than a chain grate is used, the procedure should be modified where practicable as follows:

Regulate the coal feed so as to burn the fire to the low condition required for cleaning. Shut off the coal-feeding mechanism and fill the hoppers level full. Clean the ash or dump plate, note quickly the depth and condition of the coal on the grate, the water level, the steam pressure, and the time, and record the latter as the starting time. Then start the coal-feeding mechanism, clean the ash-pit, and proceed with the regular work of the test.

When the time arrives for the close of the test, shut off the coal-feeding mechanism, fill the hoppers and burn the fire to the same low point as at the beginning. When this condition is reached, note the water level, the steam pressure, and the time, and record the latter as the stopping time. Finally clean the ash plate and haul the ashes.

In the case of chain-grate stokers, the desired operating conditions should be maintained for half an hour before starting a test and for a like period before its close, the height of the stoker gate or throat plate and the speed of the grate being the same during both these periods.

#### RECORDS.

Half-hourly readings of the instruments are usually sufficient. If there are sudden and wide fluctuations, the readings in such cases should be taken every fifteen minutes, and in some instances oftener.

The coal should be weighed and delivered to the firemen in portions sufficient for one hour's run, thereby ascertaining the degree of uniformity of firing. An ample supply of coal should be maintained at all times, but the quantity on the floor at the end of each hour should be as small as practicable, so that the same may be readily estimated and deducted from the total weight.

The records should be such as to ascertain also the consumption of feed-water each hour, and thereby determine the degree of uniformity of evaporation.

#### QUALITY OF STEAM.

If the boiler does not produce superheated steam the percentage of moisture in the steam should be determined by the use of a throttling or separating calorimeter. If the boiler has superheating surface, the temperature of the steam should be determined by the use of a thermometer inserted in a thermometer well.

#### SAMPLING AND DRYING COAL.

During the progress of the test the coal should be regularly sampled for the purpose of analysis and determination of moisture.

#### ASHES AND REFUSE.

The ashes and refuse withdrawn from the furnace and ash-pit during the progress of the test and at its close should be weighed so far as possible in a dry state. If wet, the amount of moisture should be ascertained and allowed for, a sample being taken and dried for this purpose. This sample may serve also for analysis and the determination of unburned carbon.

#### CALORIFIC TESTS AND ANALYSES OF COAL.

The quality of the fuel should be determined by calorific tests and analyses of the coal sample above referred to.

## ANALYSES OF FLUE GASES.

For approximate determinations of the composition of the flue gases, the Orsat apparatus, or some modification thereof, should be employed. If momentary samples are obtained the analyses should be made as frequently as possible, say every 15 to 30 minutes, depending on the skill of the operator, noting at the time the sample is drawn the furnace and firing conditions. If the sample drawn is a continuous one, the intervals may be made longer.

## SMOKE OBSERVATIONS.

In tests of bituminous coals requiring a determination of the amount of smoke produced, observations should be made regularly throughout the trial at intervals of five minutes (or if necessary every minute), noting at the same time the furnace and firing conditions. For tests of furnaces, methods of firing, or smoke prevention devices, observations every 10 or 15 seconds, continued during an hour, are advisable.

## CALCULATION OF RESULTS.

- (a) *Corrections for Quality of Steam.*—When the percentage of moisture is less than 2 per cent it is sufficient merely to deduct the percentage from the weight of water fed, in which case the factor of correction for quality is

$$1 - \frac{\% \text{ moisture}}{100}.$$

When the percentage is greater than 2 per cent, or if extreme accuracy is required, the factor of correction is

$$1 - P \frac{H - h_1}{H - h}$$

in which  $P$  is the proportion of moisture,  $H$  the total heat of 1 lb. of saturated steam,  $h_1$  the heat in water at the temperature of saturated steam, and  $h$  the heat in water at the feed temperature.

When the steam is superheated the factor of correction for quality of steam is

$$\frac{H_s - h}{H - h}$$

in which  $H_s$  is the total heat of 1 lb. of superheated steam of the observed temperature and pressure.

- (b) *Correction for Live Steam, if any, used for Aiding Combustion.*—The quantity of steam or power, if any, used for producing blast, injecting fuel, or aiding combustion should be determined and recorded in the table of data and results.
- (c) *Equivalent Evaporation.*—The equivalent evaporation from and at  $212^\circ$  is obtained by multiplying the weight of water evaporated, corrected for moisture in steam, by the "factor of evaporation." The latter equals

$$\frac{H - h}{970.4}$$

in which  $H$  and  $h$  are respectively the total heat of saturated steam and of the feed-water entering the boiler.

The "factor of evaporation" and the "factor of correction for quality of steam" may be combined into one expression in the case of superheated steam as follows:

$$\frac{H_s - h}{970.4}$$

- (d) *Efficiency.*—The "efficiency of boiler, furnace and grate" is the relation between the heat absorbed per pound of coal fired, and the calorific value of 1 lb. of coal.

The "efficiency based on combustible" is the relation between



the heat absorbed per pound of combustible burned, and the calorific value of 1 lb. of combustible. This expression of efficiency furnishes a means for comparing the results of different tests, when the losses of unburned coal due to grates, cleanings, etc., are eliminated.

The "combustible burned" is determined by subtracting from the weight of coal supplied to the boiler, the moisture in the coal, the weight of ash and unburned coal withdrawn from the furnace and ash-pit, and the weight of dust, soot, and refuse, if any, withdrawn from the tubes, flues, and combustion chambers, including ash carried away in the gases, if any, determined from the analyses of coal and ash. The "combustible" used for determining the calorific value is the weight of coal less the moisture and ash found by analysis.

The "heat absorbed" per pound of coal or combustible is calculated by multiplying the equivalent evaporation from and at 212° per pound of coal or combustible by 970.4.

CHART.

In trials having for an object the determination and exposition of the complete boiler performance, the entire log of readings and data should be plotted on a chart and represented graphically.

Data and Results of Evaporative Test.\*

1. Test of . . . . . boiler located at . . . . .
2. Number and kind of boilers . . . . .
3. Kind of furnace . . . . .
4. Grate surface (width . . . . . length . . . . .) . . . . . sq. ft.
5. Water heating surface . . . . . sq. ft.
6. Superheating surface . . . . . sq. ft.
7. Total heating surface . . . . . sq. ft.
  - e. Distance from center of grate to nearest heating surface . . . . . ft.

DATE, DURATION, ETC.

8. Date . . . . .
9. Duration . . . . . hrs.
10. Kind and size of coal . . . . .

AVERAGE PRESSURES, TEMPERATURES, ETC.

11. Steam pressure by gage . . . . . lbs. per sq. in.
12. Temperature of steam, if superheated . . . . . degs.
13. Temperature of feed-water entering boiler . . . . . degs.
14. Temperature of escaping gases leaving boiler . . . . . degs.
15. Force of draft between damper and boiler . . . . . ins.
  - c. Draft in furnace . . . . . ins.
  - d. Draft or blast in ash-pit . . . . . ins.
16. State of weather . . . . .
  - a. Temperature of external air . . . . . degs.
  - b. Temperature of air entering ash-pit . . . . . degs.
  - c. Relative humidity of air entering ash-pit . . . . . degs.

QUALITY OF STEAM

17. Percentage of moisture in steam or degrees of superheating . . . . . % or degs.
18. Factor of correction for quality of steam . . . . . % or degs.

TOTAL QUANTITIES.

19. Total weight of coal as fired . . . . . lbs.
20. Percentage of moisture in coal as fired . . . . . per cent.
21. Total weight of dry coal fired . . . . . lbs.

\* This table contains the principal items of the table in the Code of 1915 of the A.S.M.E. Committee on Power Tests.

22. Total ash, clinkers, and refuse (dry).....	lbs.
23. Total combustible burned (Item 21—Item 22) .....	lbs.
24. Percentage of ash and refuse in dry coal.....	per cent.
25. Total weight of water fed to boiler.....	lbs.
26. Total water evaporated, corrected for quality of steam (Item 25 × Item 18) .....	lbs.
27. Factor of evaporation based on temperature of water entering boiler.....	
28. Total equivalent evaporation from and at 212° (Item 26 × Item 27).....	lbs.

## HOURLY QUANTITIES AND RATES.

29. Dry coal per hour.....	lbs.
30. Dry coal per square foot of grate surface per hour.....	lbs.
31. Water evaporated per hour, corrected for quality of steam.....	lbs.
32. Equivalent evaporation per hour from and at 212°.....	lbs.
33. Equivalent evaporation per hour from and at 212° per square foot of water-heating surface.....	lbs.

## CAPACITY.

34. Evaporation per hr. from and at 212° (same as Item 32) lbs.	
<i>a.</i> Boiler horse-power developed (Item 34 ÷ 34 <sup>1/2</sup> )....	Bl. H.P.
35. Rated capacity per hour, from and at 212°.....	lbs.
<i>a.</i> Rated boiler horse-power.....	Bl. H.P.
36. Percentage of rated capacity developed.....	per cent.

## ECONOMY.

37. Water fed per pound of coal as fired (Item 25 ÷ Item 19)	lbs.
38. Water evaporated per pound of dry coal (Item 26 ÷ Item 21).....	lbs.
39. Equivalent evaporation from and at 212° per pound of coal as fired (Item 28 ÷ Item 19).....	lbs.
40. Equivalent evaporation from and at 212° per pound of dry coal (Item 28 ÷ Item 21).....	lbs.
41. Equivalent evaporation from and at 212° per pound of combustible (Item 28 ÷ Item 23).....	lbs.

## EFFICIENCY.

42. Calorific value of 1 lb. of dry coal by calorimeter.....	B.T.U.
43. Calorific value of 1 lb. of combustible by calorimeter..	B.T.U.
44. Efficiency of boiler, furnace and grate.....	per cent.

$$100 \times \frac{\text{Item 40} \times 970.4}{\text{Item 42}}$$

45. Efficiency based on combustible.....	per cent.
--	-----------

$$100 \times \frac{\text{Item 41} \times 970.4}{\text{Item 43}}$$

## COST OF EVAPORATION.

46. Cost of coal per ton of... lbs. delivered in boiler room.	dollars.
47. Cost of coal required for evaporating 1000 lbs. of water under observed conditions.....	dollars.
48. Cost of coal required for evaporating 1000 lbs. of water from and at 212°.....	dollars.

## SMOKE DATA.

49. Percentage of smoke as observed.....	per cent.
--	-----------

## FIRING DATA.

50. Kind of firing, whether spreading, alternate, or coking <i>a.</i> Average interval between times of leveling or breaking up.....	min.
--	------

ANALYSES AND HEAT BALANCE.

51. Analysis of dry gases by volume.
- a. Carbon dioxide (CO<sub>2</sub>)..... per cent.
  - b. Oxygen (O)..... per cent.
  - c. Carbon monoxide (CO)..... per cent.
  - d. Hydrogen and hydrocarbons..... per cent.
  - e. Nitrogen, by difference (N)..... per cent.

52. Proximate analysis of coal

	As Fired.	Dry Coal.	Combustible.
a. Moisture		-----	-----
b. Volatile Matter		-----	-----
c. Fixed carbon		-----	-----
d. Ash		-----	-----
	-----	-----	-----
	100%	100%	100%

e. Sulphur, separately determined, referred to dry coal. per cent.

53. Ultimate analysis of dry coal.
- a. Carbon (C)..... per cent.
  - b. Hydrogen (H)..... per cent.
  - c. Oxygen (O)..... per cent.
  - d. Nitrogen (N)..... per cent.
  - e. Sulphur (S)..... per cent.
  - f. Ash..... per cent.

54. Analysis of ash and refuse, etc. ....

55. Heat balance, based on dry coal and combustible.

	Dry Coal. $\frac{1}{2}$	
	B.T.U.	Per cent.
a. Heat absorbed by the boiler (Item 40 or $41 \times 970.4$ ).....		
b. Loss due to evaporation of moisture in coal.....		
c. Loss due to heat carried away by steam formed by the burning of hydrogen.....		
d. Loss due to heat carried away in the dry flue gases.....		
e. Loss due to carbon monoxide.....		
f. Loss due to combustible in ash and refuse.....		
g. Loss due to heating moisture in air.....		
h. Loss due to unconsumed hydrogen and hydrocarbons, to radiation, and unaccounted for.....		
i. Total calorific value of 1 lb. of dry coal or combustible. (Items 42 and 43).....		-----
		100

If it is desired that the heat balance be based on coal "as fired," or on combustible burned, the items in the first column are multiplied by  $(100 - \text{Item } 20) \div 100$  for coal as fired or by  $100 \div (100 - \text{Item } 55 f,$  per cent) for combustible.

PRINCIPAL DATA AND RESULTS OF BOILER TEST.

1. Grate surface (width.....length.....)..... sq. ft.
2. Total heating surface..... sq. ft.
3. Date.....
4. Duration..... hrs.
5. Kind and size of coal.....



6. Steam pressure by gage.....	lbs. per sq. in.
7. Temperature of feed water entering boiler.....	degs.
8. Percentage of moisture in steam or number of degrees of superheating.....	% or deg.
9. Percentage of moisture in coal.....	per cent.
10. Dry coal consumed per hour.....	lbs.
11. Dry coal consumed per square foot of grate surface per hour.....	lbs.
12. Equivalent evaporation per hour from and at 212°.....	lbs.
13. Equivalent evaporation per hour from and at 212° per square foot of heating surface.....	lbs.
14. Rated capacity per hour, from and at 212°.....	lbs.
15. Percentage of rated capacity developed.....	per cent.
16. Equivalent evaporation from and at 212° per pound of dry coal.....	lbs.
17. Equivalent evaporation from and at 212° per pound of combustible.....	lbs.
18. Calorific value of 1 lb. of dry coal by calorimeter.....	B.T.U.
19. Calorific value of 1 lb. of combustible by calorimeter..	B.T.U.
20. Efficiency of boiler, furnace and grate.....	per cent.
21. Efficiency based on combustible.....	per cent.

### FACTORS OF EVAPORATION.

The figures in the table on the next four pages are calculated from the formula  $F = (H - h) \div 970.4$ , in which  $H$  is the total heat above 32° of 1 lb. of steam of the observed pressure,  $h$  the total heat above 32° of the feed-water, and 970.4 the heat of vaporization, or latent heat, of steam at 212° F. The values of these total heats and of the latent heat are those given in Marks and Davis's steam tables.

The factors are given for every 3° of feed-water temperature between 32° and 212°, and for every 5 or 10 lbs. steam pressure within the ordinary working limits of pressure. Intermediate values correct to the third decimal place may easily be found by interpolation.

The factors in the table are for dry saturated steam only.

### STRENGTH OF STEAM-BOILERS. VARIOUS RULES FOR CONSTRUCTION.

There is a great lack of uniformity in the rules prescribed by different writers and by legislation governing the construction of steam-boilers. In the United States, boilers for merchant vessels must be constructed according to the rules and regulations prescribed by the Board of Supervising Inspectors of Steam Vessels; in the U. S. Navy, according to rules of the Navy Department, and in some cases according to special acts of Congress. On land, in some States, such as Massachusetts and Ohio, and in some cities in other States, the construction of boilers is governed by local laws; but in many places there are no laws upon the subject, and boilers are constructed according to the idea of individual engineers and boiler-makers. In recent years, however, there has been a great improvement in this matter. The wide publication of the Massachusetts boiler rules, the activity of the American Boiler Manufacturers' Association, of the American Society for Testing Materials, and the work of a committee of the American Society of Mechanical Engineers, which completed its "Boiler Code" in 1915 (issued in pamphlet form by the Society), have all tended to bring about a great degree of uniformity in the materials and the methods of boiler construction. The matter on the following pages consists chiefly of extracts from the Massachusetts rules and the A. S. M. E. Boiler Code, and is condensed from a fuller treatment of the subject in the second edition of the author's "Steam Boiler Economy."

**Materials Used in Boilers.**—For the shells, tubes, rivets and braces the material now in almost universal use is a special kind of soft open-hearth steel, low in sulphur and phosphorus and of a tensile strength not exceeding 65,000 lb. per sq. in. for shell plates and not exceeding 55,000 lb. per sq. in. for rivets.

Cast iron is used for fire-doors, grate-bars, manhole and handhole

(Continued on p. 913.)

	Lbs.									
Gauge press. . . 0.3	10.3	20.3	30.3	40.3	50.3	60.3	70.3	80.3	85.3	100.
Abs. press. . . 15.	25.	35.	45.	55.	65.	75.	85.	95.	100.	
Feed water.	Factors of Evaporation.									
212° F.	1.0003	1.0103	1.0169	1.0218	1.0258	1.0290	1.0316	1.0340	1.0361	1.0370
209	34	34	1.0200	50	89	1.0321	47	71	92	1.0401
206	65	65	31	81	1.0320	52	79	1.0402	1.0423	32
203	96	96	62	1.0312	51	83	1.0410	33	54	63
200	1.0127	1.0227	93	43	82	1.0414	41	64	85	94
197	58	58	1.0324	74	1.0413	45	72	95	1.0516	1.0525
194	89	89	55	1.0405	44	76	1.0503	1.0526	47	56
191	1.0220	1.0320	86	36	75	1.0507	34	57	78	87
188	51	51	1.0417	67	1.0506	38	65	88	1.0609	1.0618
185	82	82	48	98	37	69	96	1.0619	40	49
182	1.0313	1.0413	79	1.0529	68	1.0600	1.0627	50	71	80
179	44	44	1.0510	60	99	31	58	81	1.0702	1.0711
176	75	75	41	91	1.0630	62	89	1.0712	33	42
173	1.0406	1.0506	72	1.0622	61	93	1.0720	43	64	73
170	37	37	1.0603	53	92	1.0724	51	74	95	1.0804
167	68	68	34	84	1.0723	55	82	1.0805	1.0826	35
164	99	99	65	1.0715	54	86	1.0812	36	57	66
161	1.0530	1.0630	96	45	85	1.0817	43	67	88	97
158	61	61	1.0727	76	1.0816	47	74	98	1.0919	1.0928
155	92	92	58	1.0807	46	78	1.0905	1.0929	50	59
152	1.0623	1.0723	89	38	77	1.0909	36	60	80	90
149	54	54	1.0820	69	1.0908	40	67	91	1.1011	1.1021
146	85	85	51	1.0900	39	71	98	1.1022	42	52
143	1.0715	1.0815	81	31	70	1.1002	1.1029	52	73	82
140	46	46	1.0912	62	1.1001	33	60	83	1.1104	1.1113
137	77	77	43	93	32	64	91	1.1114	35	44
134	1.0808	1.0908	74	1.1023	63	95	1.1121	45	66	75
131	39	39	1.1005	54	93	1.1125	52	76	97	1.1206
128	70	70	36	85	1.1124	56	83	1.1207	1.1227	37
125	1.0901	1.1001	67	1.1116	55	87	1.1214	38	58	68
122	31	31	97	47	86	1.1218	45	69	89	98
119	62	62	1.1128	78	1.1217	49	76	99	1.1320	1.1329
116	93	93	59	1.1209	48	80	1.1306	1.1330	51	60
113	1.1024	1.1124	90	39	79	1.1310	37	61	82	91
110	55	55	1.1221	70	1.1309	41	68	92	1.1412	1.1422
107	86	86	52	1.1301	40	72	99	1.1423	43	53
104	1.1116	1.1216	82	32	71	1.1403	1.1430	53	74	83
101	47	47	1.1313	63	1.1402	34	61	84	1.1505	1.1514
98	78	78	44	93	33	65	91	1.1515	36	45
95	1.1209	1.1309	75	1.1424	63	95	1.1522	46	66	76
92	40	40	1.1406	55	94	1.1526	53	77	97	1.1607
89	71	71	37	86	1.1525	57	84	1.1608	1.1628	37
86	1.1301	1.1401	67	1.1518	56	88	1.1615	38	59	68
83	32	32	98	48	87	1.1619	46	69	90	99
80	63	63	1.1529	78	1.1618	50	76	1.1700	1.1721	1.1730
77	94	94	60	1.1609	48	80	1.1707	31	51	61
74	1.1425	1.1525	91	40	79	1.1711	38	62	82	92
71	55	55	1.1621	71	1.1710	42	69	92	1.1813	1.1822
68	86	86	52	1.1702	41	73	1.1800	1.1823	44	53
65	1.1517	1.1617	83	33	72	1.1804	30	54	75	84
62	48	48	1.1714	63	1.1803	35	61	85	1.1906	1.1915
59	79	79	45	94	33	65	92	1.1916	37	46
56	1.1610	1.1710	76	1.1825	64	96	1.1923	47	67	77
53	41	41	1.1807	56	95	1.1927	54	78	98	1.2008
50	72	72	38	87	1.1926	58	85	1.2009	1.2029	39
47	1.1703	1.1803	69	1.1918	57	89	1.2016	40	60	70
44	34	34	1.1900	49	88	1.2020	47	71	91	1.2101
41	65	65	31	80	1.2019	51	78	1.2102	1.2122	32
38	96	96	62	1.2011	50	82	1.2109	33	53	63
35	1.1827	1.1927	93	42	81	1.2113	40	64	84	94
32	58	58	1.2024	73	1.2113	44	71	95	1.2216	1.2225

Gauge press. 90.3 Abs. press. 105.		Lbs. 95.3 110.	100.3 115.	105.3 120.	110.3 125.	115.3 130.	120.3 135.	125.3 140.	130.3 145.	135.3 150.	140.3 155.
Feed water.	Factors of Evaporation.										
212° F.	1.0379	1.0387	1.0396	1.0404	1.0411	1.0418	1.0425	1.0431	1.0437	1.0443	1.0449
209	1.0410	1.0419	1.0427	35	42	49	56	62	68	74	80
206	41	50	58	66	73	81	87	93	99	1.0505	1.0511
203	72	81	89	97	1.0504	1.0512	1.0518	1.0524	1.0530	36	43
200	1.0504	1.0512	1.0520	1.0528	35	43	49	55	61	67	74
197	35	43	51	59	66	74	80	86	92	98	1.0605
194	66	74	82	90	97	1.0605	1.0611	1.0617	1.0623	1.0629	36
191	97	1.0605	1.0613	1.0621	1.0629	36	42	48	54	60	67
188	1.0628	36	44	52	60	67	73	79	85	91	98
185	59	67	75	83	91	98	1.0704	1.0710	1.0716	1.0722	1.0729
182	90	98	1.0706	1.0714	1.0721	1.0729	35	41	47	53	60
179	1.0721	1.0729	37	45	52	60	66	72	78	84	91
176	52	60	68	76	83	91	97	1.0803	1.0809	1.0815	1.0822
173	82	91	99	1.0807	1.0814	1.0822	1.0828	34	40	46	53
170	1.0813	1.0822	1.0830	38	45	53	59	65	71	77	83
167	44	53	61	69	76	84	90	96	1.0902	1.0908	1.0914
164	75	84	92	1.0900	1.0907	1.0914	1.0921	1.0927	33	39	45
161	1.0906	1.0914	1.0923	31	38	45	52	58	64	70	76
158	37	45	54	62	69	76	82	89	95	1.1001	1.1007
155	68	76	85	93	1.1000	1.1007	1.1013	1.1020	1.1026	32	38
152	99	1.1007	1.1015	1.1024	31	38	44	51	57	63	69
149	1.1030	38	46	55	62	69	75	81	88	94	1.1100
146	61	69	77	86	93	1.1100	1.1106	1.1112	1.1119	1.1125	31
143	92	1.1100	1.1108	1.1116	1.1124	31	37	43	49	56	62
140	1.1123	31	39	47	54	62	68	74	80	86	93
137	53	62	70	78	85	93	99	1.1205	1.1211	1.1217	1.1224
134	84	93	1.1201	1.1209	1.1216	1.1223	1.1230	36	42	48	54
131	1.1215	1.1223	32	40	47	54	60	67	73	79	85
128	46	54	62	71	78	85	91	98	1.1304	1.1310	1.1316
125	77	85	93	1.1302	1.1309	1.1316	1.1322	1.1328	35	41	47
122	1.1308	1.1316	1.1324	32	40	47	53	59	65	71	78
119	39	47	55	63	70	78	84	90	95	1.1402	1.1409
116	69	78	86	94	1.1401	1.1408	1.1415	1.1421	1.1427	33	39
113	1.1400	1.1408	1.1417	1.1425	32	39	45	52	58	64	70
110	31	39	47	56	63	70	76	82	89	95	1.1501
107	62	70	78	87	94	1.1501	1.1507	1.1513	1.1519	1.1526	32
104	92	1.1501	1.1509	1.1517	1.1525	32	38	44	50	56	63
101	1.1523	32	40	48	55	63	69	75	81	87	93
98	54	62	71	79	86	93	1.1600	1.1606	1.1612	1.1618	1.1624
95	85	93	1.1602	1.1610	1.1617	1.1624	30	37	43	49	55
92	1.1616	1.1624	32	41	48	55	61	67	74	80	86
89	47	55	63	71	79	86	92	98	1.1704	1.1711	1.1717
86	78	86	94	1.1702	1.1710	1.1717	1.1723	1.1729	35	41	48
83	1.1708	1.1717	1.1725	33	40	48	54	60	65	72	78
80	39	47	56	64	71	78	85	91	97	1.1803	1.1809
77	70	78	86	95	1.1802	1.1809	1.1815	1.1822	1.1828	34	40
74	1.1801	1.1809	1.1817	1.1826	33	40	46	52	59	65	71
71	32	40	48	56	64	71	77	83	89	95	1.1902
68	62	71	79	87	94	1.1902	1.1908	1.1914	1.1920	1.1926	33
65	93	1.1902	1.1910	1.1918	1.1925	33	39	45	51	57	63
62	1.1924	32	41	49	56	63	70	76	82	88	94
59	55	63	72	80	87	94	1.2000	1.2007	1.2013	1.2019	1.2025
56	86	94	1.2002	1.2011	1.2018	1.2025	31	38	44	50	56
53	1.2017	1.2025	33	42	49	56	62	68	75	81	87
50	48	56	64	73	80	87	93	99	1.2106	1.2112	1.2118
47	79	87	95	1.2104	1.2111	1.2118	1.2124	1.2130	37	43	49
44	1.2110	1.2118	1.2126	35	42	49	55	61	68	74	80
41	41	49	57	66	73	80	86	92	99	1.2205	1.2211
38	72	80	88	97	1.2204	1.2211	1.2217	1.2223	1.2230	36	42
35	1.2203	1.2211	1.2219	1.2228	35	42	48	55	61	67	73
32	34	42	51	59	66	73	79	86	92	98	1.2304



Gauge press.	Lbs.										
	145.3	150.3	155.3	160.3	165.3	170.3	175.3	180.3	185.3	190.3	195.3
Abs. press.	.160.	165.	170.	175.	180.	185.	190.	195.	200.	205.	210
Feed water.	Factors of Evaporation.										
212° F.	1.0454	1.0460	1.0464	1.0469	1.0474	1.0478	1.0483	1.0487	1.0492	1.0496	1.0499
209	86	91	95	1.0500	1.0505	1.0509	1.0514	1.0519	1.0523	1.0527	1.0530
206	1.0517	1.0522	1.0526	31	36	40	45	50	54	58	61
203	48	53	57	62	67	71	77	81	85	89	92
200	79	84	88	93	98	1.0602	1.0608	1.0612	1.0616	1.0620	1.0623
197	1.0610	1.0615	1.0619	1.0624	1.0629	33	39	43	47	51	54
194	41	46	50	55	60	64	70	74	78	82	85
191	72	77	81	86	91	95	1.0701	1.0705	1.0709	1.0713	1.0716
188	1.0703	1.0708	1.0712	1.0717	1.0722	1.0727	32	36	40	44	47
185	34	39	43	48	53	58	63	67	71	75	78
182	65	70	74	79	84	88	94	98	1.0802	1.0806	1.0809
179	96	1.0801	1.0805	1.0810	1.0815	1.0819	1.0825	1.0829	33	37	40
176	1.0827	32	36	41	46	50	56	60	64	68	71
173	58	63	67	72	77	81	87	91	95	99	1.0902
170	89	94	98	1.0903	1.0908	1.0912	1.0917	1.0922	1.0926	1.0930	33
167	1.0920	1.0925	1.0929	34	39	43	48	53	57	61	64
164	51	56	60	65	70	74	79	84	88	92	95
161	81	87	91	96	1.1001	1.1005	1.1010	1.1014	1.1019	1.1023	1.1026
158	1.1012	1.1018	1.1022	1.1027	32	36	41	45	49	54	57
155	43	48	53	58	63	67	72	76	80	85	88
152	74	79	83	89	94	98	1.1103	1.1107	1.1111	1.1115	1.1119
149	1.1105	1.1110	1.1114	1.1120	1.1125	1.1129	34	38	42	46	49
146	36	41	45	50	56	60	65	69	73	77	80
143	67	72	76	81	86	91	96	1.1200	1.1204	1.1208	1.1211
140	98	1.1203	1.1207	1.1212	1.1217	1.1221	1.1227	31	35	39	42
137	1.1229	34	38	43	48	52	58	62	66	70	73
134	59	65	69	74	79	83	88	92	97	1.1301	1.1304
131	90	95	1.1300	1.1305	1.1310	1.1314	1.1319	1.1323	1.1327	32	35
128	1.1321	1.1326	30	36	41	45	50	54	58	62	66
125	52	57	61	66	72	76	81	85	89	93	96
122	83	88	92	97	1.1402	1.1407	1.1412	1.1416	1.1420	1.1424	1.1427
119	1.1414	1.1419	1.1423	1.1428	33	37	43	47	51	55	58
116	45	50	54	59	64	68	73	78	82	86	89
113	75	81	85	90	95	99	1.1504	1.1508	1.1512	1.1515	1.1520
110	1.1506	1.1511	1.1515	1.1521	1.1526	1.1530	35	39	43	47	50
107	37	42	46	51	57	61	66	70	74	78	81
104	68	73	77	82	87	92	97	1.1601	1.1605	1.1609	1.1612
101	99	1.1604	1.1608	1.1613	1.1618	1.1622	1.1627	32	36	40	43
98	1.1629	35	39	44	49	53	58	62	67	71	74
95	60	65	70	75	80	84	89	93	97	1.1701	1.1705
92	91	96	1.1700	1.1705	1.1711	1.1715	1.1720	1.1724	1.1728	32	35
89	1.1722	1.1727	31	36	42	46	51	55	59	63	66
86	53	58	62	67	72	76	82	86	90	94	97
83	84	89	93	98	1.1803	1.1807	1.1812	1.1817	1.1821	1.1825	1.1828
80	1.1814	1.1820	1.1824	1.1829	34	38	43	47	52	56	59
77	45	50	54	60	65	69	74	78	82	86	90
74	76	81	85	90	96	1.1900	1.1905	1.1909	1.1913	1.1917	1.1920
71	1.1907	1.1912	1.1916	1.1921	1.1926	31	36	40	44	48	51
68	38	43	47	52	57	61	67	71	75	79	82
65	69	74	78	83	88	92	97	1.2002	1.2006	1.2010	1.2013
62	99	1.2005	1.2009	1.2014	1.2019	1.2023	1.2028	32	36	41	44
59	1.2030	35	40	45	50	54	59	63	67	72	75
56	61	66	70	76	81	85	90	94	98	1.2102	1.2106
53	92	97	1.2101	1.2107	1.2112	1.2116	1.2121	1.2125	1.2129	33	36
50	1.2123	1.2128	32	37	43	47	52	56	60	64	67
47	54	59	63	68	74	78	83	87	91	95	98
44	85	90	94	1.2200	1.2205	1.2209	1.2214	1.2218	1.2222	1.2226	1.2229
41	1.2216	1.2221	1.2225	31	36	40	45	49	53	57	60
38	47	52	56	62	67	71	76	80	84	88	91
35	78	83	88	93	98	1.2302	1.2307	1.2311	1.2315	1.2320	1.2323
32	1.2309	1.2315	1.2319	1.2324	1.2329	33	38	42	46	51	54

	Lbs. Gauge press. 200.3	205.3	210.3	215.3	220.3	225.3	230.3	235.3	240.3	245.3	250.3
	Abs. press. . . 215.	220.	225.	230.	235.	240.	245.	250.	255.	260.	265.
Feed water.	Factors of Evaporation.										
212° F.	1.0503	1.0507	1.0510	1.0513	1.0517	1.0520	1.0523	1.0527	1.0529	1.0533	1.0535
209	34	38	41	44	48	52	55	58	60	64	66
206	65	69	72	75	79	83	86	89	91	95	97
203	96	1.0600	1.0603	1.0606	1.0611	1.0614	1.0617	1.0620	1.0622	1.0626	1.0629
200	1.0627	31	34	37	42	45	48	51	53	57	60
197	58	62	65	68	73	76	79	82	84	88	91
194	89	93	96	1.0700	1.0704	1.0707	1.0710	1.0713	1.0715	1.0719	1.0722
191	1.0720	1.0724	1.0727	31	35	38	41	44	46	50	53
188	51	55	58	62	66	69	72	75	78	81	84
185	82	86	89	93	97	1.0800	1.0803	1.0806	1.0809	1.0812	1.0815
182	1.0813	1.0817	1.0820	1.0823	1.0828	31	34	37	39	43	46
179	44	48	51	54	59	62	65	68	70	74	77
176	75	79	82	86	90	93	96	99	1.0901	1.0905	1.0908
173	1.0906	1.0910	1.0913	1.0916	1.0921	1.0924	1.0927	1.0930	32	36	39
170	37	41	44	47	51	55	58	61	63	67	69
167	68	72	75	78	82	86	89	92	94	98	1.1001
164	99	1.1003	1.1006	1.1009	1.1013	1.1016	1.1019	1.1023	1.1025	1.1029	31
161	1.1030	34	37	40	44	47	50	54	56	60	62
158	61	65	68	71	75	78	81	85	87	91	93
155	92	96	99	1.1102	1.1106	1.1109	1.1112	1.1115	1.1118	1.1122	1.1124
152	1.1123	1.1127	1.1130	33	37	40	43	46	49	53	55
149	54	58	61	64	68	71	74	77	80	83	86
146	84	89	92	95	99	1.1202	1.1205	1.1208	1.1211	1.1214	1.1217
143	1.1215	1.1219	1.1223	1.1226	1.1230	33	36	39	42	45	48
140	46	50	53	56	61	64	67	70	72	76	79
137	77	81	84	87	92	95	98	1.1301	1.1303	1.1307	1.1310
134	1.1308	1.1312	1.1315	1.1318	1.1322	1.1326	1.1329	32	34	38	40
131	39	43	46	49	53	56	59	62	65	69	71
128	70	74	77	80	84	87	90	93	96	1.1400	1.1402
125	1.1400	1.1405	1.1408	1.1411	1.1415	1.1418	1.1421	1.1424	1.1427	30	33
122	31	35	39	42	46	49	52	55	58	61	64
119	62	66	69	72	77	80	83	86	88	92	95
116	93	97	1.1500	1.1503	1.1507	1.1511	1.1514	1.1517	1.1519	1.1523	1.1525
113	1.1524	1.1528	31	34	38	41	44	48	50	54	56
110	55	59	62	65	69	72	75	78	81	85	87
107	85	90	93	96	1.1600	1.1603	1.1606	1.1609	1.1612	1.1615	1.1618
104	1.1616	1.1620	1.1624	1.1627	31	34	37	40	43	46	49
101	47	51	54	57	61	65	68	71	73	77	80
98	78	82	85	88	92	95	98	1.1702	1.1704	1.1708	1.1710
95	1.1709	1.1713	1.1716	1.1719	1.1723	1.1726	1.1729	32	35	39	41
92	39	44	47	50	54	57	60	63	66	69	72
89	70	75	78	81	85	88	91	94	97	1.1800	1.1803
86	1.1801	1.1805	1.1808	1.1812	1.1816	1.1819	1.1822	1.1825	1.1827	31	34
83	32	36	39	42	46	50	53	56	58	62	64
80	63	67	70	73	77	80	83	87	89	93	95
77	94	98	1.1901	1.1904	1.1908	1.1911	1.1914	1.1917	1.1920	1.1924	1.1926
74	1.1924	1.1929	32	35	39	42	45	48	51	54	57
71	55	59	63	66	70	73	76	79	82	85	88
68	86	90	93	96	1.2001	1.2004	1.2007	1.2010	1.2012	1.2016	1.2019
65	1.2017	1.2021	1.2024	1.2027	31	35	38	41	43	47	49
62	48	52	55	58	62	65	68	72	74	78	80
59	79	83	86	89	93	96	99	1.2102	1.2105	1.2109	1.2111
56	1.2110	1.2114	1.2117	1.2120	1.2124	1.2127	1.2130	33	36	40	42
53	41	45	48	51	55	58	61	64	67	70	73
50	71	76	79	82	86	89	92	95	98	1.2201	1.2204
47	1.2202	1.2207	1.2210	1.2213	1.2217	1.2220	1.2223	1.2226	1.2229	32	35
44	34	38	41	44	48	51	54	57	60	63	66
41	65	69	72	75	79	82	85	88	91	94	97
38	96	1.2300	1.2303	1.2306	1.2310	1.2313	1.2316	1.2319	1.2322	1.2325	1.2328
35	1.2327	31	34	37	41	44	47	50	53	57	59
32	58	62	65	68	72	75	78	82	84	88	90

plates, headers of water-tube boilers (for pressures under 160 lb.), mud drums (not exceeding 18 in. diameter), and nozzles for pipe attachments, but there is a tendency to substitute rolled or forged steel for all these purposes except grate-bars.

**Quality of Steel.** (A. S. M. E. Boiler Code, 1915.)

FLANGE.		FIREBOX.		
Carbon . . . . .	. . . . .	} Plates 3/4 in. thick and under . . . . .	0.12—0.25 %	
				} Plates over 3/4 in. thick . . . . .
Manganese . . . . .	0.30—0.60 %	0.30—0.50		
Phosphorus {	Acid . . . . .	Not over 0.05	Not over . . . . .	0.04
	Basic . . . . .	Not over 0.04	Not over . . . . .	0.035
Sulphur . . . . .	Not over 0.05	Not over . . . . .	Not over . . . . .	0.04
Copper . . . . .		Not over . . . . .	Not over . . . . .	0.05
Tensile strength, lb. per sq. in. . . . .	55,000—65,000	55,000—63,000		
Yield point, min., lb. per sq. in. . . . .	0.5 tens. str.	0.5 tens. str.		
Elongation in 8-in., min., per cent	1,500,000	1,500,000		
	Tens. str.	Tens. str.		

For material over 3/4 in. in thickness a deduction of 0.5 from the percentage of elongation shall be made for each increase of 1/8 in. in thickness above 3/4 in., to a minimum of 20%.

Cold bending and quench bending tests are also required, and for fire-box steel a homogeneity test (see page 507).

Rivet steel: Tensile strength, 45,000-55,000, Elongation in 8 in. 1,500,000 ÷ tensile strength, but need not exceed 30%. Stay bolt steel, T. S., 50,000-60,000.

**Quench-bend Tests.**—The test specimen, when heated to a light cherry red as seen in the dark (not less than 1200° F.), and quenched at once in water the temperature of which is between 80° and 90°, shall bend through 180° without cracking on the outside of the bent portion, as follows: For material 1 in. or under in thickness, flat on itself; for material over 1 in. in thickness, around a pin of a diameter equal to the thickness.

Boiler tubes are now generally made of soft steel, but charcoal iron tubes are still preferred by some users.

**Shells; Water and Steam Drums.**—The cylindrical structure, including the ends, of a fire-tube boiler, is usually called the shell. The cylinder superposed on the tubes of a water-tube boiler is called a water and steam drum. Shells of marine boilers of the Scotch type have been built of diameters as large as 16 ft. Water and steam drums of water-tube boilers are rarely made of greater diameter than 42 in.

The thickness of shell for a given pressure is found from the common formula for safe strength of thin cylinders,

$$P = 2tTf \div dF; \text{ whence } t = PdF \div 2Tf.$$

$P$  = safe working pressure;  $T$  = tensile strength of plate, both in lb. per sq. in.,  $t$  = thickness of plate in inches;  $f$  = ratio of the strength of a riveted joint to that of the solid plate;  $F$  = factor of safety allowed; and  $d$  = diameter of shell or drum in inches.

The value taken for  $T$  is commonly that stamped on the plates by the manufacturer,  $f$  is taken from tables of strength of riveted joints or is computed, and  $F$  must be taken at a figure not less than is prescribed by local or State laws, or, in the case of marine boilers, by the rules of the U. S. Board of Supervising Inspectors, and may be more than this figure if a greater margin of safety is desired.

**Strength of Circumferential Seam.**—Safe working pressure  $P = 4tTf \div dF$ ;  $t = PdF \div 4Tf$ , notation as above. The strength of a shell against rupture on a circumferential line is twice that against rupture on a longitudinal line, therefore single riveting is sufficient on the circumferential seams while double, triple or quadruple riveting is used for the longitudinal seams.

**Thickness of Plates; Riveting.** (Mass. Boiler Rules, 1910).—The longitudinal joints of a boiler, the shell or drum of which exceeds 36 in. diameter, shall be of butt and double strap construction; if it does not



exceed 36 in. lap-riveted construction may be used, the maximum pressure on such shells being 100 lb. per sq. in.

Minimum thickness of plates in flat-stayed surfaces,  $\frac{5}{16}$  in.

The ends of staybolts shall be riveted over or upset.

Rivets shall be of sufficient length to completely fill the rivet holes and form a head equal in strength to the body of the rivet.

Rivets shall be machine driven wherever possible, with sufficient pressure to fill the rivet holes, and shall be allowed to cool and shrink under pressure.

Rivet holes shall be drilled full size with plates, butt straps and heads bolted in position; or they may be punched not to exceed  $\frac{1}{4}$  in. less than full size for plates over  $\frac{5}{16}$  in. thick, and  $\frac{1}{8}$  in. or less for plates not exceeding  $\frac{5}{16}$  in. thick, and then drilled or reamed to full size with plates, butt straps and heads bolted up in position.

The longitudinal joints of horizontal return-tubular boilers shall be located above the fire-line of the setting.

The thickness of plates in a shell or drum shall be of the same gage. Minimum thickness of shell plates (Mass. Rules and A. S. M. E. Code): Diam. 36 in. or under,  $\frac{1}{4}$  in.; over 36 to 54 in.,  $\frac{5}{16}$  in.; over 54 to 72 in.,  $\frac{3}{8}$  in.; over 72 in.,  $\frac{1}{2}$  in.

Minimum thickness of butt straps:

Plates, in.	$\frac{1}{4}$ to $\frac{11}{32}$	$\frac{3}{8}$ to $\frac{13}{32}$	$\frac{7}{16}$ to $\frac{15}{32}$	$\frac{1}{2}$ to $\frac{9}{16}$	$\frac{5}{8}$ to $\frac{3}{4}$	$\frac{7}{8}$	$\frac{11}{8}$	$\frac{11}{4}$
Straps, in.	$\frac{1}{4}$	$\frac{5}{16}$	$\frac{3}{8}$	$\frac{7}{16}$	$\frac{1}{2}$	$\frac{5}{8}$	$\frac{3}{4}$	$\frac{7}{8}$

Minimum thickness of tube sheets:

Diam. of tube sheet, in. . . . .	42 or under	Over 42 to 54	Over 54 to 72	Over 72
Thickness, in. . . . .	$\frac{3}{8}$	$\frac{7}{16}$	$\frac{1}{2}$	$\frac{9}{16}$

**Convex or Bumped Heads.**—Minimum thickness of convex heads,  $t = \frac{1}{4}d F P \div T$ ;  $d$  = diameter in inches;  $F = 5$  = factor of safety;  $P$  = working pressure, lb. per sq. in.;  $T$  = tensile strength stamped on the head.

When a convex head has a manhole opening the thickness is to be increased not less than  $\frac{1}{8}$  in.

When the head is of material of the same quality and thickness as that of the shell, the head is of equal strength with the shell when the radius of curvature of the head equals the diameter of the shell, or when the rise of the curve = 0.134 diam. of shell.

[The A. S. M. E. Boiler Code specifies a higher factor of safety, 5.5, and adds  $\frac{1}{8}$  in. to the thickness, making the formula  $t = 2.75 PR/T + \frac{1}{8}$  in.,  $R$  being the radius to which the head is dished, in inches. When  $R$  is less than  $0.8 d$  the thickness shall be at least that found by the formula when  $R = 0.8 d$ . Dished heads with the pressure on the convex side are allowed a maximum working pressure equal to 60% of that for heads of the same dimensions with the pressure on the concave side. When the dished head has a manhole opening the thickness as found by these rules shall be increased by not less than  $\frac{1}{8}$  in. The corner radius of a dished head shall be not less than  $1\frac{1}{2}$  in. nor more than 4 in., and not less than  $0.03R$ . A manhole opening in a dished head shall be flanged to a depth not less than three times the thickness of the head measured from the outside.]

**Efficiency of Riveted Joints.** (Mass. Boiler Rules, 1910.)\*

$X$  = efficiency = ratio of strength of unit length of riveted joint to the strength of the same length of a solid plate.

$T$  = tensile strength of the material, in pounds per square inch.

$t$  = thickness of plate, in inches.

$b$  = thickness of butt strap, in inches.

$P$  = pitch of rivets, in inches, on the row having the greatest pitch.

$d$  = diameter of rivet, after driving, in inches.

$a$  = cross-section of rivet after driving, in square inches.

$s$  = strength of rivet in single shear, in pounds per square inch.

$S$  = strength of rivet in double shear, in pounds per square inch.

\* The same rules are given in the A. S. M. E. Boiler Code of 1914, which was modeled on the Massachusetts Rules.

$c$  = crushing strength of rivet, in pounds per square inch.  
 $n$  = number of rivets in single shear in a length of joint equal to  $P$ .  
 $N$  = number of rivets in double shear in the same length of joint.

For single-riveted lap joints:

$A$  = strength of solid plate =  $PtT$ .

$B$  = strength of plate between rivet holes =  $(P - d)tT$ .

$C$  = shearing strength of one rivet =  $nsa$ .

$D$  = crushing strength of plate in front of one rivet =  $dtc$ .

$X = \frac{B}{A}$  or  $\frac{C}{A}$  or  $\frac{D}{A}$ , whichever is least.

For double-riveted lap joints:

$A$  and  $B$  as above,  $C$  and  $D$  to be taken for two rivets.

$X = B, C, \text{ or } D$  (whichever is least) divided by  $A$ .

For butt and double strap joint, double-riveted:

$A$  = strength of solid plate =  $PtT$ .

$B$  = strength of plate between rivet holes in the outer row =  $(P - d)tT$ .

$C$  = shearing strength of two rivets in double shear, plus shearing strength of one rivet in single shear =  $NSa + nsa$ .

$D$  = strength of plate between rivet holes in the second row, plus the shearing strength of one rivet in single shear in the outer row =  $(P - 2d)tT + nsa$ .

$E$  = strength of plate between rivet holes in the second row, plus the crushing strength of butt strap in front of one rivet in the outer row =  $(P - 2d)tT + dbc$ .

$F$  = crushing strength of plate in front of two rivets, plus the crushing strength of butt strap in front of one rivet =  $Ndtc + ndbc$ .

$G$  = crushing strength of plate in front of two rivets, plus the shearing strength of one rivet in single shear =  $Ndtc + nsa$ .

$X = B, C, D, E, F, \text{ or } G$  (whichever is least) divided by  $A$ .

For butt and double strap joint, triple-riveted:

The same as for double-riveted, except that four rivets instead of two are taken for  $N$  in computing  $C, F, \text{ and } G$ .

For butt and double strap joint, quadruple-riveted:

$A, B, \text{ and } D$  the same as for double-riveted joints.

$C$  = shearing strength of eight rivets in double shear and three rivets in single shear =  $NSa + nsa$ .

$E$  = strength of plate between rivet holes in the third row (the outer row being the first) plus the shearing strength in single shear of two rivets in the second row and one rivet in the outer row =  $(P - 4d)tT + nsa$ .

$F$  = strength of plate between rivet holes in the second row, plus the crushing strength of butt strap in front of one rivet in the outer row =  $(P - 2d)tT + dbc$ .

$G$  = strength of plate between rivet holes in the third row, plus the crushing strength of butt strap in front of two rivets in the second row and one rivet in the outer row =  $(P - 4d)tT + ndbc$ .

$H$  = crushing strength of plate in front of eight rivets, plus the crushing strength of butt strap in front of three rivets =  $Ndtc + ndbc$ .

$I$  = crushing strength of plate in front of eight rivets, plus the shearing strength in single shear of two rivets in the second row and one in the outer row =  $Ndtc + nsa$ .

$X = B, C, D, E, F, G, H, \text{ or } I$  (whichever is least) divided by  $A$ .

The Massachusetts Rules allow the crushing strength of mild steel to be taken at 95,000 lb. per sq. in. The maximum shearing strength of rivets, in lb. per sq. in. of cross-section, is taken as follows:

In single shear, iron, 38,000; steel, 42,000.

In double shear, iron, 70,000; steel, 78,000.

The A. S. M. Boiler Code also allows 95,000 lb. per sq. in. for crushing strength, but for shearing strength of rivets allows:

In single shear, iron 38,000; steel 44,000.

In double shear, iron 76,000; steel 88,000.

**Allowable Stresses on Braces and Staybolts.** (Massachusetts Rules.)—The maximum allowable stress per square inch net cross-sectional area of stays and staybolts shall be as follows: Weldless mild steel, head to head or through stays, 8000 lb., 9000 lb.; diagonal or crow-foot stays, 7500 lb., 8000 lb.; mild steel or wrought-iron staybolts 6500 lb., 7000 lb. The first figure in each case is for size up to  $1\frac{1}{4}$  in. diameter or equivalent area, the second for size over  $1\frac{1}{4}$  in. or equivalent area.

The A. S. M. E. Boiler Code allows for welded stays 6000 lb. per sq. in.; for unwelded stays (a) 7500; (b) 9500; (c) 8500. (a) less than 20 diameters long, screwed through plates with ends riveted over; (b) lengths between supports not exceeding 120 diameters; (c) exceeding 120 diameters.

**Allowable Pressure on Staybolted Surfaces.**—The U. S. Supervising Inspectors' rule (for steamboat service) is:

$$P = kt^2 \div S^2$$

$P$  = allowable pressure, lb. per sq. in.,  $S$  = maximum pitch in inches,  $t$  = thickness in sixteenths of an inch,  $k$  = 112 for plates up to  $\frac{7}{16}$  in., and 120 for plates over  $\frac{7}{16}$  in.

The A. S. M. E. Boiler Code gives the same formula with the following values of the constants: For stays screwed through plates with ends riveted over, plates not over  $\frac{7}{16}$  in. thick,  $C = 112$ ; over  $\frac{7}{16}$  in. thick,  $C = 120$ ; for stays screwed through plates and fitted with single nuts outside of plate,  $C = 135$ ; for stays fitted with inside nuts and outside washers, the diameters of washers not less than  $0.4 S$  and thickness not less than  $t$ ,  $C = 175$ .

**Staybolts.**—Staybolts in water-legs are subject not only to longitudinal stress due to the boiler pressure, and to corrosion, but also to bending stress caused by relative motions of the outer and inner sheets of the furnace or waterleg due to the variations in temperature to which the two are subjected. A staybolt usually fails by transverse fracture close to the outer sheet, which is supposed to be due to the fact that the fire-box sheet is generally thinner than the outer sheet, and therefore holds the end of the stay less rigidly. Staybolts are sometimes drilled with a small hole at one end through which water will be blown out as soon as a fracture extends far enough across the section to reach the hole, thus calling attention to the failure of the stay. A better form is one in which the hole extends the whole length of the stay. The inner portion of the stay is turned to  $\frac{1}{8}$  in. smaller diameter than the ends, in order to make the stay more flexible and diminish the chances of fracture.

**Tube Spacing in Horizontal Tubular Boilers.**—In modern practice the tubes are arranged in vertical and horizontal rows (not staggered as in earlier practice), with not less than 1 in. space between adjacent tubes, not less than 2 in. between the two central vertical rows, and not less than  $2\frac{1}{2}$  in. between the shell and the nearest tube. In boilers 60 in. diameter and larger a manhole is put in the front head beneath the central rows of tubes.

**Tubes and Tube Holes.** (Mass. Boiler Rules.)—Tube holes shall be drilled full size, or they may be punched not to exceed  $\frac{1}{2}$  in. less than the full size, and then drilled, reamed or finished full size with a rotating cutter. The edge of tube holes shall be chamfered to a radius of about  $\frac{1}{16}$  in. A fire-tube boiler shall have the ends of the tubes substantially beaded. The ends of all tubes, suspension tubes and nipples shall be flared not less than  $\frac{1}{8}$  in. over the diameter of the tube hole on all water-tube boilers and superheaters, and shall project through the tube sheets or headers not less than  $\frac{1}{4}$  in. nor more than  $\frac{1}{2}$  in. Separately fired superheaters shall have the tube ends protected by refractory material where they connect with drums or headers.

**Holding Power of Expanded Tubes.** (*The Locomotive*, Sept., 1893.)—Tubes 3 in. external diameter, 0.109 in. thick were expanded in a  $\frac{3}{8}$ -in. plate by rolling with a Dudgeon expander, without the projecting part being flared or beaded. Stress was applied to draw the tubes out of the plates. The observed stress which caused yielding was, in three specimens, 6500, 5000 and 7500 lb. Two other specimens were flared so that the diameter of the extreme end of the tube pro-



jecting  $\frac{3}{16}$  in. beyond the plate was 3.2 in., the diameter of the tube where it entered the plate being 3.1 in. The observed stress which caused the yielding of these specimens was 21,000 and 19,500 lb. *The Locomotive* estimates that the factor of safety of the plain rolled tubes is nearly 4 and that of the flared tubes about 15 against the stress to which they are subjected in a boiler at 100 lb. gage pressure. It is considered that the tubes act as stays for that portion of the flat head that is within two inches of the upper row of tubes, and that the segment above this (except that portion that lies with 3 in. of the shell) requires to be braced.

**Size of Boiler Tubes.**—The following table gives the dimensions of the tubes commonly used in steam-boilers, together with their calculated surface per foot of length, and the length per square foot of surface, internal and external:

Dimensions of Standard Boiler Tubes

External Diameter, In.	Standard Thickness, In.	Inside Diameter, In.	Inside Surface per Foot of Length.	Length per Sq. ft. of Inside Surface.	Outside Surface per Foot of Length, Sq. ft.	Length, per Sq. ft. Outside Surface, Ft.	Internal Area, Sq. ft.	External Area, Sq. ft.
2	0.095	1.810	0.4738	2.110	0.5236	1.910	0.0179	0.0218
2 $\frac{1}{4}$	.095	2.060	.5393	1.854	.5890	1.698	.0231	.0276
2 $\frac{1}{2}$	.109	2.282	.5974	1.674	.6545	1.528	.0284	.0341
2 $\frac{3}{4}$	.109	2.532	.6629	1.508	.7199	1.389	.0350	.0412
3	.109	2.782	.7283	1.373	.7854	1.273	.0422	.0491
3 $\frac{1}{4}$	.120	3.010	.7880	1.269	.8508	1.175	.0494	.0576
3 $\frac{1}{2}$	.120	3.260	.8535	1.172	.9163	1.091	.0580	.0668
3 $\frac{3}{4}$	.120	3.510	.9189	1.088	.9817	1.018	.0672	.0767
4	.134	3.732	.9770	1.024	1.0472	0.955	.0760	.0873

**Flues Subjected to External Pressure.**—The rules of the U. S. Board of Supervising Inspectors, Steamboat Inspection Service, 1909, give the following rules for flues subjected to external pressure only:

Plain lap-welded flues 7 to 13 in. diameter.

**Furnaces.**—The tensile strength of steel used in the construction of corrugated or ribbed furnaces shall not exceed 67,000, and be not less than 54,000 lb.; and in all other furnaces the minimum tensile strength shall not be less than 58,000, and the maximum not more than 67,000 lb. The minimum elongation in 8 inches shall be 20%.

All corrugated furnaces having plain parts at the ends not exceeding 9 inches in length (except flues especially provided for), when new, and made to practically true circles, shall be allowed a steam pressure in accordance with the formula  $P = C \times T \div D$ .

$P$  = pressure in lb. per sq. in.,  $T$  = thickness in inches,  $C$  = a constant, as below.

Leeds suspension bulb furnace...  $C = 17,000$ ,  $T$  not less than  $\frac{5}{16}$  in.

Morison corrugated type...  $C = 15,600$ ,  $T$  not less than  $\frac{5}{16}$  in.

Fox corrugated type...  $C = 14,000$ ,  $T$  not less than  $\frac{5}{16}$  in.

Purves type, rib projections...  $C = 14,000$ ,  $T$  not less than  $\frac{7}{16}$  in.

Brown corrugated type...  $C = 14,000$ ,  $T$  not less than  $\frac{5}{16}$  in.

Type having sections 18 ins. long  $C = 10,000$ ,  $T$  not less than  $\frac{7}{16}$  in.

Limiting dimensions from center of the corrugations or projecting ribs, and of their depth, are given for each furnace.

**Working Pressure on Boilers with Triple Riveted Joints.**—A triple riveted double butt and strap joint, carefully designed, may be made to have an efficiency something higher than 85 per cent. Good boiler plate steel may be considered to have a tensile strength of 55,000 lb. per sq. in. Taking these figures and a factor of safety of 5, we have safe working pressure

$$P = \frac{2Tt}{dF} = \frac{2 \times 55,000 \times t \times 0.85}{5d} = \frac{18700t}{d},$$

from which the following table is calculated.

## Safe Working Pressure for Shells with Joints of 85% Efficiency.

Thickness, In. . .	1/4	5/16	3/8	7/16	1/2	9/16	5/8	11/16	3/4	13/16	7/8	15/16	1
Diameter, In.													
24.....	195	247											
30.....	156	195	234										
36.....	130	162	195	227	260								
42.....	111	139	167	195	223	250							
48.....		122	146	170	195	219	243						
54.....		108	130	151	173	195	216	238					
60.....			117	136	156	175	195	214	233				
66.....			106	124	142	159	177	195	212	230			
72.....				114	130	146	162	179	195	211	227		
78.....					120	135	150	165	180	195	210	225	
84.....						125	139	153	167	181	195	209	223
90.....						117	130	143	156	169	182	195	208
96.....							121	134	146	158	170	183	195

Shells of externally fired boilers are rarely made over  $\frac{9}{16}$  in. thick.

**Pressures Allowed on Boilers.** (Mass. Boiler Rules.)—The pressure allowed on a boiler constructed wholly of cast iron shall not exceed 25 lb. per sq. in.

The pressure allowed on a boiler the tubes of which are secured to cast-iron headers shall not exceed 160 lb. per sq. in.

The maximum pressure to be allowed on a shell or drum of a boiler shall be determined from the minimum thickness of the shell plates, the lowest tensile strength stamped on the plates by the manufacturer, the efficiency of the longitudinal joint or of the ligament between the tube holes, whichever is least, the inside diameter of the outside course, and a factor of safety not less than five.

The lowest factor of safety to be used for boilers the shells or drums of which are exposed to the products of combustion, and the longitudinal joints of which are lap riveted, shall be as follows: 5 for boilers not over 10 years old; 5.5 for boilers over 10 and not over 15 years old; 5.75 for boilers over 15 and not over 20 years old; 6 for boilers over 20 years old. The lowest factor of safety to be used for boilers the longitudinal joints of which are of butt and double strap construction is 4.5.

A hydrostatic test is to be applied if in the judgment of the inspector or of the insurance company it is advisable. The maximum pressure in a hydrostatic test shall not exceed  $1\frac{1}{2}$  times the maximum allowable working pressure, except that twice the maximum allowable working pressure may be applied on boilers permitted to carry not over 25 lb. pressure, or on pipe boilers.

**Fusible Plugs.**—(A. S. M. E. Code.) Fusible plugs, if used, shall be filled with tin with a melting point between 400 and 500° F. The least diameter of fusible metal shall be not less than  $\frac{1}{2}$  in., except for maximum allowable working pressures of over 175 lb. per sq. in. or when it is necessary to place a fusible plug in a tube, in which case the least diameter of fusible metal shall be not less than  $\frac{3}{8}$  in.

**Steam-domes.**—Steam-domes or drums were formerly almost universally used on horizontal boilers, but their use is now generally discontinued, as they are considered a useless appendage to a steam-boiler, and unless properly designed and constructed are an element of weakness.

## IMPROVED METHODS OF FEEDING COAL.

**Mechanical Stokers.** (William R. Roney, *Trans. A. S. M. E.*, vol. xii.)—Mechanical stokers have been used in England to a limited extent since 1785. In that year one was patented by James Watt. (See D. K. Clark's *Treatise on the Steam-engine.*)

After 1840 many styles of mechanical stokers were patented in England, but nearly all were variations and modifications of the two forms of stokers patented by John Jukes in 1841 and by E. Henderson in 1843.

The Jukes stoker consisted of longitudinal fire-bars, connected by

links, so as to form an endless chain. The small coal was delivered from a hopper on the front of the boiler, on to the grate, which, slowly moving from front to rear, gradually advanced the fuel into the furnace and discharged the ash and clinker at the back.

The Henderson stoker consists primarily of two horizontal fans revolving on vertical spindles, which scatter the coal over the fire.

The first American stoker was the Murphy stoker, brought out in 1878. It consists of two coal magazines placed in the side walls of the boiler furnace, and extending back from the boiler front 6 or 7 feet. In the bottom of these magazines are rectangular iron boxes, which are moved from side to side by means of a rack and pinion, and serve to push the coal upon the grates, which incline at an angle of about 35° from the inner edge of the coal magazines, forming a V-shaped receptacle for the burning coal. The grates are composed of narrow parallel bars, so arranged that each alternate bar lifts about an inch at the lower end, while at the bottom of the V, and filling the space between the ends of the grate-bars, is placed a cast-iron toothed bar, arranged to be turned by a crank. The purpose of this bar is to grind the clinker coming in contact with it. Over this V-shaped receptacle is sprung a fire-brick arch.

In the Roney mechanical stoker the fuel to be burned is dumped into a hopper on the boiler front. Set in the lower part of the hopper is a "pusher," which, by a vibratory motion, gradually forces the fuel over the "dead-plate" and on the grate. The grate-bars in their normal condition form a series of steps. Each bar is capable of a rocking motion through an adjustable angle. All the grate-bars are coupled together by a "rocker-bar." A variable back-and-forth motion being given to the "rocker-bar," through a connecting-rod, the grate-bars rock in unison, now forming a series of steps, and now approximating to an inclined plane, with the grates partly overlapping, like shingles on a roof. When the grate-bars rock forward the fire will tend to work down in a body. But before the coal can move too far the bars rock back to the stepped position, checking the downward motion. The rocking motion is slow, being from 7 to 10 strokes per minute, according to the kind of coal. This alternate starting and checking motion is continuous, and finally lands the cinder and ash on the dumping-grate below.

**The Hawley Down-draught Furnace.**—A foot or more above the ordinary grate there is carried a second grate, composed of a series of water-tubes, opening at both ends into steel drums or headers, through which water is circulated. The coal is fed on this upper grate, and as it is partially consumed falls through it upon the lower grate, where the combustion is completed in the ordinary manner. The draught through the coal on the upper grate is downward through the coal and the grate. The volatile gases are therefore carried down through the bed of coal, where they are thoroughly heated, and are burned in the space beneath, where they meet the excess of hot air drawn through the fire on the lower grate. In tests in Chicago, from 30 to 45 lb. of coal were burned per square foot of grate upon this system, with good economical results. (See catalogue of the Hawley Down-draught Furnace Co., Chicago.)

**The Chain Grate Stoker**, made by Jukes in 1841, is now (1909) widely used in the United States. It is made by the Babcock & Wilcox Co., Green Engineering Co., and others.

**Under-feed Stokers.**—Results similar to those that may be obtained with downward draught are obtained by feeding the coal at the bottom of the bed, pushing upward the coal already on the bed which has had its volatile matter distilled from it. The volatile matter of the freshly fired coal then has to pass through a body of ignited coke, where it meets a supply of hot air. (See circular of The Underfeed Stoker Co., Chicago.)

**The Taylor Gravity Stoker** is a combination of an underfeed stoker containing two horizontal rows of pushers with an inclined or step grate through which air is blown by a fan.

**The Riley Stoker** is an underfeed stoker with a single horizontal row of pushers in combination with moving grate-bars, and moving pushers at the rear of the furnace for continuously dumping the refuse.



**SMOKE PREVENTION.**

The following article was contributed by the author to a "Report on Smoke Abatement," presented by a committee to the Syracuse Chamber of Commerce, published by the Chamber in 1907.

Smoke may be made in two ways: (1) By direct distillation of tarry condensible vapors from coal without burning; (2) By the partial burning or splitting up of hydrocarbon gases, the hydrogen burning and the carbon being left unburned as smoke or soot. These causes usually act conjointly.

The direct cause of smoke is that the gases distilled from the coal are not completely burned in the furnace before coming in contact with the surface of the boiler, which chills them below the temperature of ignition.

The amount and quality of smoke discharged from a chimney may vary all the way from a dense cloud of jet-black smoke, which may be carried by a light wind for a distance of a mile or more before it is finally dispersed into the atmosphere, to a thin cloud, which becomes invisible a few feet from the chimney. Often the same chimney will for a few minutes immediately after firing give off a dense black cloud and then a few minutes later the smoke will have entirely disappeared.

The quantity and density of smoke depend upon many variable causes. Anthracite coal produces no smoke under any conditions of furnace. Semi-bituminous, containing 12.5 to 25% of volatile matter in the combustible part of the coal, will give off more or less smoke, depending on the conditions under which it is burned, and bituminous coal, containing from 25 to 50% of volatile matter, will give off great quantities of smoke with all of the usual old-style furnaces, even with skillful firing, and this smoke can only be prevented by the use of special devices, together with proper methods of firing the fuel and of admission of air.

Practically the whole theory of smoke production and prevention may be illustrated by the flame of an ordinary gas burner or gas stove. When the gas is turned down very low every particle of gas, as it emerges from the burner, is brought in contact with a sufficient supply of hot air to effect its complete and instantaneous combustion, with a pale blue or almost invisible flame. Turn on the gas a little more and a white flame appears. The gas is imperfectly burned in the center of the flame. Particles of carbon have been separated which are heated to a white heat. If a cold plate is brought in contact with the white flame, these carbon particles are deposited as soot. Turn on the gas still higher, and it burns with a dull, smoky flame, although it is surrounded with an unlimited quantity of air. Now, carry this smoky flame into a hot fire-brick or porcelain chamber, where it is brought in contact with very hot air, and it will be made smokeless by the complete burning of the particles.

We thus see: (1) That smoke may be prevented from forming if each particle of gas, as it is made by distillation from coal, is immediately mixed thoroughly with hot air, and (2) That even if smoke is formed by the absence of conditions for preventing it, it may afterwards be burned if it is thoroughly mixed with air at a sufficiently high temperature. It is easy to burn smoke when it is made in small quantities, but when made in great volumes it is difficult to get the hot air mixed with it unless special apparatus is used. In boiler firing the formation of smoke must be prevented, as the conditions do not usually permit of its being burned. The essential conditions for preventing smoke in boiler fires may be enumerated as follows:

1. The gases must be distilled from the coal at a uniform rate.
2. The gases, when distilled, must be brought into intimate mixture with sufficient hot air to burn them completely.
3. The mixing should be done in a fire-brick chamber.
4. The gases should not be allowed to touch the comparatively cold surfaces of the boiler until they are completely burned. This means that the gases shall have sufficient space and time in which to burn before they are allowed to come in contact with the boiler surface.

Every one of these four conditions is violated in the ordinary method of burning coal under a steam boiler. (1) The coal is fired intermittently and often in large quantities at a time, and the distillation proceeds at so rapid a rate that enough air cannot be introduced into the furnace to burn the gas. (2) The piling of fresh coal on the grate in itself chokes the air

supply. (3) The roof of the furnace is the cold shell, or tubes, of the boiler, instead of a fire-brick arch, as it should be, and the furnace is not of a sufficient size to allow the gases time and space in which to be thoroughly mixed with the air supply.

In order to obtain the conditions for preventing smoke it is necessary: (1) That the coal be delivered into the furnace in small quantities at a time. (2) That the draught be sufficient to carry enough air into the furnace to burn the gases as fast as they are distilled. (3) That the air itself be thoroughly heated either by passing through a bed of white-hot coke or by passing through channels in hot brickwork, or by contact with hot fire-brick surfaces. (4) That the gas and the air be brought into the most complete and intimate mixture, so that each particle of carbon in the gas meets, before it escapes from the furnace, its necessary supply of air. (5) That the flame produced by the burning shall be completely extinguished by the burning of every particle of the carbon into invisible carbon dioxide.

If a white flame touches the surface of a boiler, it is apt to deposit soot and to produce smoke. A white flame itself is the visible evidence of incomplete combustion.

The first remedy for smoke is to obtain anthracite coal. If this is not commercially practicable, then obtain, if possible, coal with the smallest amount of volatile matter. Coal of from 15 to 25% of volatile matter makes much less smoke than coals containing higher percentages. Provide a proper furnace for burning coal. Any furnace is a proper furnace which secures the conditions named in the preceding paragraphs. Next, compel the firemen to follow instructions concerning the method of firing.

It is impossible with coal containing over 30% of volatile matter and with a water-tube boiler, with tubes set close to the grate and vertical gas passages, as in an anthracite setting, to prevent smoke even by the most skillful firing. This style of setting for a water-tube boiler should be absolutely condemned. A Dutch oven setting, or a longitudinal setting with fire-brick baffle walls, is highly recommended as a smoke-preventing furnace, but with such a furnace it is necessary to use considerable skill in firing.

Mechanical mixing of the gases and the air by steam jets is sometimes successful in preventing smoke, but it is not a universal preventive, especially when the coal is very high in volatile matter, when the firing is done unskillfully, or when the boiler is being driven beyond its normal capacity. It is essential to have sufficient draught to burn the coal properly and this draught may be obtained either from a chimney or a fan. There is no especial merit in forced draught, except that it enables a larger quantity of coal to be burned and the boiler to be driven harder in case of emergency, and usually the harder the boiler is driven, the more difficult it is to suppress smoke.

Down-draught furnaces and mechanical stokers of many different kinds are successfully used for smoke prevention, and when properly designed and installed and handled skillfully, and usually at a rate not beyond that for which they are designed, prevent all smoke. If these appliances are found giving smoke, it is always due either to overdriving or to unskillful handling. It is necessary, however, that the design of these stokers be suited to the quality of the coal and the quantity to be burned, and great care should be taken to provide a sufficient size of furnace with a fire-brick roof and means of introducing air to make them completely successful.

**Burning Illinois Coal without Smoke.** (L. P. Breckenridge, Bulletin No. 15 of the Univ. of Ill. Eng'g Experiment Station, 1907.) — Any fuel may be burned economically and without smoke if it is mixed with the proper amount of air at a proper temperature. The boiler plant of the University of Illinois consists of nine units aggregating 2000 H.P. Over 200 separate tests have been made. The following is a condensed statement of the results in regard to smoke prevention.

Boilers Nos. 1 and 2. Babcock & Wilcox. Chain-grate stoker. Usual vertical baffling. Can be run without smoke at from 50 to 120% of rated capacity.

No. 3. Stirling boiler. Chain-grate stoker. Usual baffling and com-

bustion arches. Can be run without smoke at capacities of 50 to 140%.

No. 4. National water-tube. Chain-grate stoker. Vertical baffling. No smoke at capacities of 50 to 120%. With the Murphy furnace it was smokeless except when cleaning fires.

No. 5. Babcock & Wilcox. Roney stoker. Vertical baffling. Nearly smokeless (maximum No. 2 on a chart in which 5 represents black smoke) up to 100% of rating, but cannot be run above 100% without objectionable smoke.

No. 6. Babcock & Wilcox. Roney stoker. Horizontal tile-roof baffling. Can be run without smoke at capacities of 50 to 100% of rating.

Nos. 7 and 8. Stirling, equipped with Stirling bar-grate stoker. Usual baffling and combustion arches. Can be run without smoke at 50 to 140% of rating.

No. 9. Heine boiler. Chain-grate stoker. Combustion arch and tile-roof furnace. Can be run without smoke at capacities of 50 to 140%. It is almost impossible to make smoke with this setting under any condition of operation. As much as 46 lbs. of coal per sq. ft. of grate surface has been burned without smoke.

**Conditions of Smoke Prevention.** — Bulletin No. 373 of the U. S. Geological Survey, 1909 (188 pages), contains a report of an extensive research by D. T. Randall and J. T. Weeks on The Smokeless Combustion of Coal in Boiler Plants. A brief summary of the conclusions reached is as follows:

Smoke prevention is both possible and economical. There are many types of furnaces and stokers that are operated smokelessly.

Stokers or furnaces must be set so that combustion will be complete before the gases strike the heating surfaces of the boiler. When partly burned gases at a temperature of say 2500° F. strike the tubes of a boiler at say 350° F., combustion may be entirely arrested.

The most economical hand-fired plants are those that approach most nearly to the continuous feed of the mechanical stoker. The fireman is so variable a factor that the ultimate solution of the problem depends on the mechanical stoker — in other words, the personal element must be eliminated.

A well designed and operated furnace will burn many coals without smoke up to a certain number of pounds per hour, the rate varying with different coals. If more than this amount is burned, the efficiency will decrease and smoke will be made, owing to the lack of furnace capacity to supply air and mix gases.

High volatile matter in the coal gives low efficiency, and vice versa. When the furnace was forced the efficiency decreased.

With a hand-fired furnace the best results were obtained when firing was done most frequently, with the smallest charge.

Small sizes of coal burned with less smoke than large sizes, but developed lower capacities.

Peat, lignite, and sub-bituminous coal burned readily in the tile-roofed furnace and developed the rated capacity, with practically no smoke.

Coals which smoked badly gave efficiencies three to five per cent lower than the coals burning with little smoke.

Briquets were found to be an excellent form for using slack coal in a hand-fired plant.

In the average hand-fired furnace washed coal burns with lower efficiency and makes more smoke than raw coal. Moreover, washed coal offers a means of running at high capacity, with good efficiency, in a well-designed furnace.

Forced draught did not burn coal any more efficiently than natural draught. It supplied enough air for high rates of combustion, but as the capacity of the boiler increased, the efficiency decreased and the percentage of black smoke increased.

Fire-brick furnaces of sufficient length and a continuous, or nearly continuous, supply of coal and air to the fire make it possible to burn most coals efficiently and without smoke.

Coals containing a large percentage of tar and heavy hydrocarbons are difficult to burn without smoke and require special furnaces and more than ordinary care in firing.



**FORCED COMBUSTION IN STEAM-BOILERS.**

For the purpose of increasing the amount of steam that can be generated by a boiler of a given size, forced draught is of great importance. It is universally used in the locomotive, the draught being obtained by a steam-jet in the smoke-stack. It is now largely used in ocean steamers, especially in ships of war, and to a small extent in stationary boilers. Economy of fuel is generally not attained by its use, its advantages being confined to the securing of increased capacity from a boiler of a given bulk, weight, or cost.

There are three different modes of using the fan for promoting combustion: 1, blowing direct into a closed ash-pit; 2, exhausting the gases by the suction of the fan; 3, forcing air into an air-tight boiler-room or stoke-hold. Each of these three methods has its advantages and disadvantages.

In the use of the closed ash-pit the blast-pressure frequently forces the gases of combustion from the joint around the furnace doors in so great a quantity as to affect both the efficiency of the boiler and the health of the firemen.

The chief defect of the second plan is the great size of the fan required to produce the necessary exhaustion, on account of the higher exit temperature enlarging the volume of the waste gases.

The third method that of forcing cold air by the fan into an air-tight boiler-room—the closed stoke-hold system—though it overcame the difficulties in working belonging to the two forms first tried, has serious defects of its own, as it cannot be worked, even with modern high-class boiler-construction, much, if at all, above the power of a good chimney draught, in most boilers, without damaging them. (J. Howden, Proc. Eng'g Congress at Chicago, in 1893.)

In 1880 Mr. Howden designed an arrangement intended to overcome the defects of both the closed ash-pit and the closed stoke-hold systems.

An air-tight chamber is placed on the front end of the boiler and surrounding the furnaces. This reservoir, which projects from 8 to 10 inches from the end of the boiler, receives the air under pressure, which is passed by valves into the ash-pits and over the fires in proportions suited to the kind of fuel and the rate of combustion. The air used above the fires is admitted to a space between the outer and inner furnace-doors, the inner having perforations and an air-distributing box through which the air passes under pressure. By means of the balance of pressure above and below the fires all tendency of the fire to blow out at the door is removed.

A feature of the system is the combination of the heating of the air of combustion by the waste gases with the controlled and regulated admission of air to the furnaces. This arrangement is effected most conveniently by passing the hot fire-gases after they leave the boiler through stacks of vertical tubes enclosed in the uptake, their lower ends being immediately above the smoke-box doors. Installations on Howden's system have been arranged for a rate of combustion to give an average of from 18 to 22 I.H.P. per square foot of fire-grate with fire-bars from 5 to 5½ ft. in length. It is believed that with suitable arrangement of proportions even 30 I.H.P. per square foot can be obtained.

For an account of uses of exhaust-fans for increasing draught, see paper by W. R. Roney, *Trans. A. S. M. E.*, vol. xv.

**Calculations for Forced Draft.**—In designing a forced draft installation the principal data needed are: 1, The maximum number of pounds of coal that will have to be burned per hour at the most rapid rate of driving, when the efficiency of the boiler, furnace and grate is lowest; 2, the number of pounds of air used per pound of coal. If C, H and O are respectively the carbon, hydrogen and oxygen in 1 lb. of coal, then the number of pounds of air required, theoretically, for complete combustion is  $34.56(C/3 + H + O/8)$ . With mechanical stokers and CO<sub>2</sub> apparatus for control of the air supply 50% excess air supply is ample, but with ordinary hand-firing the actual air supply may be 100% or more in excess. In the author's "Steam Boiler Economy," 2d ed. 1915, p. 242, there is given a calculation of the number of cubic feet of air per minute required per boiler horsepower developed, giving results as follows:

## CUBIC FEET OF AIR PER MINUTE AT 70° F. PER BOILER HORSEPOWER.

Fuel	Anth.	Semi-bit.	East. Bitu.	West. Bitu.	Lignite	Oil
Air 50% excess.....	11.52	11.30	10.99	11.86	13.63	11.13
Air 100% excess.....	15.36	15.07	14.65	15.82	16.17	14.84

Note that these figures are based not upon the rated horse-power of the boiler, but upon that actually developed, which may be far in excess of the rated power. For induced draft the figures given should be multiplied by  $(T + 460) \div 530$ , in which  $T$  is the temperature of the gases to be handled by the induced draft fan.

## FUEL ECONOMIZERS.

Economizers for boiler plants are usually made of vertical cast-iron tubes contained in a long rectangular chamber of brickwork. The feed-water enters the bank of tubes at one end, while the hot gases enter the chamber at the other end and travel in the opposite direction to the water. The tubes are made of cast iron because it is more non-corrosive than wrought iron or steel when exposed to gases of combustion at low temperatures. An automatic scraping device is usually provided for the purpose of removing dust from the outer surface of the tubes.

The amount of saving of fuel that may be made by an economizer varies greatly according to the conditions of operation. With a given quantity of chimney gases to be passed through it, its economy will be greater (1) the higher the temperature of these gases; (2) the lower the temperature of the water fed into it; and (3) the greater the amount of its heating surface. From (1) it is seen that an economizer will save more fuel if added to a boiler that is overdriven than if added to one driven at a nominal rate. From (2) it appears that less saving can be expected from an economizer in a power plant in which the feed-water is heated by exhaust steam from auxiliary engines than when the feed-water entering it is taken directly from the condenser hot-well. The amount of heating surface that should be used in any given case depends not only on the saving of fuel that may be made, but also on the cost of coal, and on the annual costs of maintenance, including interest, depreciation, etc.

The following table shows the theoretical results possibly attainable from economizers under the conditions specified. It is assumed that the coal has a heating value of 15,000 B.T.U. per lb. of combustible; that it is completely burned in the furnace at a temperature of 2500° F.; that the boiler gives efficiencies ranging from 60 to 75% according to the rate of driving; and that sufficient economizer surface is provided to reduce the temperature of the gases in all cases to 300° F. Assuming the specific heat of the gases to be constant, and neglecting the loss of heat by radiation, the temperature of the gases leaving the boiler and entering the economizer is directly proportional to  $(100 - \% \text{ of boiler efficiency})$ , and the combined efficiency of boiler and economizer is  $(2500 - 300) \div 2500 = 88\%$ , which corresponds to an evaporation of  $(15,000 \div 970) \times 0.88 = 13.608$  lb. from and at 212° per lb. of combustible; or assuming the feed-water enters the economizer at 100° F. and the boiler makes steam of 150 lb. absolute pressure, to an evaporation of 11.729 lb. under these conditions. Dividing this figure into the number of heat units utilized by the economizer per lb. of combustible gives the heat-units added to the water, from which, by reference to a steam table, the temperature may be found. With these data we obtain the results given in the table below.

Boiler Efficiency, per cent.	60	65	70	75
B.T.U. absorbed by boiler per lb. combustible.....	9000	9750	10500	11250
B.T.U. in chimney gases leaving boiler.....	6000	5250	4500	3750
Estimated temp. of gases leaving boiler.....	1000°	875°	750°	625°
Estimated temp. of gases leaving economizer.....	300°	300°	300°	300°
B.T.U. saved by economizer.....	4200	3450	2700	1950
Efficiency gained by economizer, per cent.....	28	23	18	13
Equivalent water evap. per lb. comb. in boiler.....	9.278	10.051	10.824	11.598
B.T.U. saved by econ. equivalent to evap. of lb.....	4.330	3.557	2.884	2.010
Temp. of water leaving economizer.....	448°	389°	327°	265°
Efficiency of the economizer, per cent.....	70	65.7	60	52

**Equation of the Economizer.**—Let  $W$  = lb. of water evaporated by the boiler, under actual conditions of feed-water temperature and steam pressure, per lb. of combustible;  $G$  = lb. of flue-gas per lb. combustible;  $T_1$  and  $T_2$  = temperatures of gas entering and leaving the economizer;  $t_1$  and  $t_2$  = temperatures of water entering and leaving the economizer; then assuming no loss by radiation and leakage, and taking the specific heat of the gas at 0.24 and that of the water at 1,

$$t_2 - t_1 = \frac{0.24G}{W} (T_1 - T_2) = F(T_1 - T_2),$$

in which  $F$  has the values in the following table for given values of  $W$  and  $G$ .

$W =$	8	9	10	11	12
$F = 0.24 G/W.$					
$G = 18$	0.54	0.48	0.43	0.39	0.36
21	0.63	0.56	0.50	0.46	0.42
24	0.72	0.64	0.58	0.52	0.48
27	0.81	0.72	0.65	0.59	0.54
30	0.90	0.80	0.72	0.65	0.60

$T_1$  is usually fixed by the operating conditions of the boiler, and  $t_1$  by the condenser and feed-water heater conditions.

Taking  $T_1$  at 800°, 700° and 600°, corresponding values of  $F$  at 0.49, 0.39 and 0.36, and  $t_1 = 100°$ ,

$$t_2 - 100 = 0.43(800 - T_2); \text{ let } T_2 = 300, \text{ then } t_2 = 0.43(500) + 100 = 315°$$

$$0.39(700 - T_2); \quad 250, \quad 0.39(450) + 100 = 266°$$

$$0.36(600 - T_2); \quad 220, \quad 0.36(380) + 100 = 237°$$

The mean temperature difference between the flue gas and the water,

$$t_m = \frac{T_1 + T_2}{2} - \frac{t_2 + t_1}{2} = \frac{T_1 - t_2 + T_2 - t_1}{2}.$$

For the three cases given  $t_m = 343°$ ,  $292°$ ,  $242°$ .

If  $w$  = lb. of water heated by the economizer per hour from  $t_1$  to  $t_2$ ,  $S$  = sq. ft. of economizer surface, and  $C$  = heat-units transmitted per square foot of surface per hour per degree of mean temperature difference, then  $w(t_2 - t_1) = SCt_m$ . The value of  $C$  is given by manufacturers as ranging between 2 and 4 for different conditions of practice. It probably increases in some proportion to the increase of  $t_m$ , but no records of experiments have been published from which the law of this increase may be determined.

**Amount of Heating Surface.**—The Fuel Economizer Co. says: We have found in practice that by allowing 4 sq. ft. of heating surface per boiler H.P. (34½ lb. evap. from and at 212° = 1 H.P.) we are able to raise the feed-water 60° F. for every 100° reduction in the temperature, the gases entering the economizer at 450° to 600°. With gases at 600° to 700° we have allowed a heating surface of 4½ to 5 sq. ft. per H.P., and for every 100° reduction in temperature of the gases we have obtained about 65° rise in temperature of the water; the feed-water entering at 60 to 120°. With 5000 sq. ft. of boiler-heating surface (plain cylinder boilers) developing 1000 H.P. we should recommend 5 sq. ft. of economizer surface per boiler H. P. developed, or an economizer of about 500 tubes, and it should heat the feed-water about 300°.

**Heat Transmission in Economizers.** (Carl S. Dow, *Indust. Eng'g*, April, 1909.)—The rate of heat transmission ( $C$ ) per sq. ft. per hour per degree of difference between the average temperatures of the gases and the water passing through the economizer varies with the mean temperature of the gas about as follows: Gas, 600°,  $C = 3.25$ ; gas 500°,  $C = 3$ ; gas 400°,  $C = 2.75$ ; gas 300°,  $C = 2.25$ .

**Calculation of the Saving made by an Economizer.**—The usual method of calculating the saving of fuel by an economizer when the boiler and the economizer are tested together as a unit is by the formula  $(H_1 - h) \div (H_2 - h)$ , in which  $h$  is the total heat above 32° of 1 lb. of



water entering,  $H_1$  the total heat of 1 lb. of water leaving the economizer, and  $H_2$  the total heat above  $32^\circ$  of 1 lb. of steam at the boiler pressure. If  $h = 100$ ,  $H_1 = 210$ ,  $H_2 = 1200$ , then the saving according to the formula is  $(210 - 100) \div 1100 = 10\%$ . This is correct if the saving is defined as the ratio of the heat absorbed by the economizer to the total heat absorbed by the boiler and economizer together, but it is not correct if the saving is defined as the saving of fuel made by running the combined unit as compared with running the boiler alone making the same quantity of steam from feed-water at the low temperature, so as to cause the boiler to furnish  $H_2 - h$  heat-units per lb. instead of  $H_2 - H_1$ . In this case the boiler is called on to do more work, and in doing it it may be overdriven and work with lower efficiency.

In a test made by F. G. Gasche, in Kansas City in 1897, using Missouri coal analyzing moisture 7.58; volatile matter, 36.69; fixed carbon, 35.02; ash, 15.69; sulphur, 5.12, he obtained an evaporation of 5.17 lb. from and at  $212^\circ$  per lb. of coal with the boiler alone, and when the boiler and economizer were tested together the equivalent evaporation credited to the boiler was 5.55, to the economizer 0.72, and to the combined unit 6.27, the saving by the combined unit as compared with the boiler alone being  $(6.27 - 5.17) \div 6.27 = 17.5\%$ , while the saving of heat shown by the economizer in the combined test is only  $(6.27 - 5.55) \div 6.27 = 11.5\%$ , or as calculated by Mr. Gasche from the formula  $(H_1 - h) \div (H_2 - h)$ ,  $(172.1 - 39.3) \div (1181.8 \div 39.3) = 11.6\%$ .

The maximum saving of fuel which may be made by the use of an economizer when attached to boilers that are working with reasonable economy is about 15%. Take the case of a condensing engine using steam of 125 lb. gage pressure, and with a hot-well or feed-water temperature of  $100^\circ$  F. The economizer may be expected under the best conditions to raise this temperature about  $170^\circ$  or to  $270^\circ$ . Then  $h = 68$ ,  $H_1 = 239$ ,  $H_2 = 1190$ .  $(H_1 - h) \div (H_2 - h) = 171 \div 1122 = 15.24\%$ .

If the boilers are not working with fair economy on account of being overdriven, then the saving made by the addition of an economizer may be much greater.

**Test of a Large Economizer.** (R. D. Tomlinson, *Power*, Feb., 1904.)—Two tests were made of one of the sixteen Green economizers at the 74th St. Station of the Rapid Transit Railway, New York City. Four 520-H.P. B. & W. boilers were connected to the economizer. It had 512 tubes, 10 ft. long,  $4\frac{9}{16}$  in. external diam.; total heating surface 6760 sq. ft., or 3.25 sq. ft. per rated H.P. of the boilers. Draught area through economizer, 3 sq. in. per H. P. The stack for each 16 boilers and four economizers was 280 ft. high, 17 ft. internal diam. The first test was made with the boilers driven at 94% of rating, the second at 113%. The results are given below, the figures of the second test being in parentheses.

Water entering economizer  $96^\circ$  ( $93.5^\circ$ ); leaving  $200^\circ$  ( $203.8^\circ$ ); rise 104 (110.3).

Gases entering economizer  $548^\circ$  ( $603^\circ$ ); leaving 295 (325); drop 253 (278).

Steam, gage pressure, 166 (165). Total B. T.U. per lb. from feed temp. 1132 (1134).

Saving of heat by economizer, per cent, 9.17 (9.73).

Reduction of draught in passing through economizer, in. of water, 0.16 (0.23).

**Results from Seven Tests of Sturtevant Economizers** (Catalogue of B. F. Sturtevant Co.)

Plants Tested,	Gases Entering. Deg. F.	Gases Leaving. Deg. F.	Water Entering. Deg. F.	Water Leaving. Deg. F.	Increase in Temperature.
1	650	275	180	340	160
2	575	290	160	320	160
3	470	230	130	260	130
4	500	240	110	230	120
5	460	200	90	230	140
6	440	220	120	236	116
7	525	225	180	320	140

**Explosions of Economizers.**—Explosions of economizers are rare, but their possibility should be recognized and guarded against. They may occur from over-pressure, due to closing of the outlet valve or other causes, which may be prevented by means of a safety valve. When the gas inlet damper is closed there is a possibility that it may leak combustible gas into the economizer flue, making an explosive mixture which might be ignited by a lighted torch. The headers or tubes may be weakened by internal or external corrosion, and a rupture might occur at the normal working pressure. This should be guarded against by annual inspection and hydraulic test at 50 per cent in excess of the working pressure.

### THERMAL STORAGE.

In Druitt Halpin's steam storage system (*Industries and Iron*, Mar. 22, 1895) he employs only sufficient boilers to supply the mean demand, and storage tanks sufficient to supply the maximum demand. These latter not being subjected to the fire suffer but little deterioration. The boilers working continuously at their most economical rate have their excess of energy during light load stored up in the water of the tank, from which it may be drawn at will during heavy load. He proposes that the boilers and tanks shall work under a pressure of 265 lbs. per square inch when fully charged, which corresponds to a temperature of 406° F., and that the engines be worked at 130 lbs. per square inch, which corresponds to 347° F. The total available heat stored when the reservoirs are charged is that due to a range of 59°. The falling in temperature of 14 $\frac{1}{4}$  lbs. of water from 407° to 347° will yield 1 lb. of steam. To allow for radiation of loss and imperfect working, this may be taken at 16 lbs. of water per pound of steam. The steam consumption per effective H.P. may be taken at 18 lbs. per hour in condensing and 25 lbs. per hour in non-condensing engines. The storage-room per effective H.P. by this method would, therefore, be  $(16 \times 18) \div 62.5 = 4.06$  cu. ft. for condensing and  $(16 \times 25) \div 62.5 = 6.4$  cu. ft. for non-condensing engines.

Gas storage, assuming that illuminating gas is used, would require about 20 cu. ft. of storage room per effective H.P. hour stored, and if ordinary fuel gas were stored it would require about four times this capacity. In water storage 317 cu. ft. would be required at an elevation of 100 ft. to store one H.P. hour, so that of the three methods of storing energy the thermal method is by far the most economical of space.

In the steam storage method the boiler is completely filled with water and the storage tank nearly so. The two are in free communication by means of pipes, and a constant circulation of water is maintained between the two, but the steam for the engines is taken only from the top of the storage tank through a reducing valve.

In the feed storage system, the excess of energy during light load is stored in the tank as before, but the boilers are not completely filled. In this system the steam is taken exclusively from the boilers, the superheated water of the storage tanks being used during heavy load as feed-water to the boilers.

A third method is a combination of these two. In the "combined" feed and steam storage system the pressure in boiler and storage tank is equalized by connecting the steam spaces in both by pipe, and the steam for the engines is, therefore, taken from both. In other words they work in parallel.

### INCRUSTATION AND CORROSION.

**Incrustation or Scale.**—Incrustation (as distinguished from mere sediments due to dirty water, which are easily blown out, or gathered up, by means of sediment-collectors) is due to the presence of salts in the feed-water (carbonates and sulphates of lime and magnesia for the most part), which are precipitated when the water is heated, and form hard deposits upon the boiler-plates. (See Impurities in Water, p. 720, *ante*.)

Where the quantity of these salts is not very large (12 grains per gallon, say) scale preventives may be found effective. The chemical preventives either form with the salts other salts soluble in hot water; or precipitate them in the form of soft mud, which does not adhere to the plates, and can be washed out from time to time. The selection of the chemical must depend upon the composition of the water, and it should be introduced regularly with the feed.

**EXAMPLES.**—Sulphate-of-lime scale prevented by carbonate of soda: The sulphate of soda produced is soluble in water; and the carbonate of lime falls down in grains, does not adhere to the plates, and may therefore be blown out or gathered into sediment-collectors. The chemical reaction is:

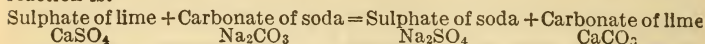

Where the quantity of salts is large, scale preventives are not of much use. Some other source of supply must be sought, or the bad water purified before it is allowed to enter the boilers. The damage done to boilers by unsuitable water is enormous.

Pure water may be obtained by collecting rain, or condensing steam by means of surface condensers. The water thus obtained should be mixed with a little bad water, or treated with a little alkali, as undiluted, pure water corrodes iron; or, after each periodic cleaning, the bad water may be used for a day or two to put a skin upon the plates.

Carbonate of lime and magnesia may be precipitated either by heating the water or by mixing milk of lime (Porter-Clark process) with it, the water being then filtered.

Corrosion may be produced by the use of pure water, or by the presence of acids in the water, caused perhaps in the engine-cylinder by the action of high-pressure steam upon the grease, resulting in the production of fatty acids. Acid water may be neutralized by the addition of lime.

**Amount of Sediment** which may collect in a 100-H.P. steam-boiler, evaporating 3000 lbs. of water per hour, the water containing different amounts of impurity in solution provided that no water is blown off:

Grains of solid impurities per U. S. gallon:										
5	10	20	30	40	50	60	70	80	90	100
Equivalent parts per 100,000:										
8.57	17.14	34.28	51.42	68.56	85.71	102.85	120	137.1	154.3	171.4
Sediment deposited in 1 hour, pounds:										
0.257	0.514	1.028	1.542	2.056	2.571	3.085	3.6	4.11	4.63	5.14
In one day of 10 hours, pounds:										
2.57	5.14	10.28	15.42	20.56	25.71	30.85	36.0	41.1	46.3	51.4
In one week of 6 days, pounds:										
15.43	30.85	61.7	92.55	123.4	154.3	185.1	216.0	246.8	277.6	308.5

If a 100-H.P. boiler has 1200 sq. ft. heating-surface, one week's running without blowing off, with water containing 100 grains of solid matter per gallon in solution, would make a scale nearly 0.02 in. thick, if evenly deposited all over the heating-surface, assuming the scale to have a sp. gr. of 2.5 = 156 lbs. per cu. ft.:  $0.02 \times 1200 \times 156 \times \frac{1}{12} = 312$  lbs.

**Effect of Scale on Boiler Efficiency.**—The following statement, or a similar one, has been published and republished for 40 years or more by makers of "boiler compounds," feed-water heaters and water-purifying apparatus, but the author has not been able to trace it to its original source:\*

"It has been estimated that scale  $\frac{1}{50}$  of an inch thick requires the burning of 5 per cent of additional fuel; scale  $\frac{1}{25}$  of an inch thick requires 10 per cent more fuel;  $\frac{1}{16}$  of an inch of scale requires 15 per cent additional fuel;  $\frac{1}{8}$  of an inch, 30 per cent., and  $\frac{1}{4}$  of an inch, 66 per cent."

The absurdity of the last statement may be shown by a simple calculation. Suppose a clean boiler is giving 75% efficiency with a furnace temperature of 2400° F. above the atmospheric temperature. Neglecting the radiation and assuming a constant specific heat for the gases, the temperature of the chimney gases will be 600°. A certain amount of fuel and air supply will furnish 100 lbs. of gas. In the boiler with  $\frac{1}{4}$  in.

\* A committee of the Am. Ry. Mast. Mechs. Assn. in 1872 quoted from a paper by Dr. Jos. G. Rodgers before the Am. Assn. for Adv. of Science (date not stated): "It has been demonstrated [how and by whom not stated] that a scale  $\frac{1}{16}$  in. thick requires the expenditure of 15% more fuel. As the scale thickens the ratio increases; thus when it is  $\frac{1}{4}$  in. thick, 60% more is required."



scale 66% more fuel will make 66 lbs. more gas. As the extra fuel does no work in evaporating water, its heat must all go into the chimney gas. We have then in the chimney gases

100 lbs. at 600° F., product	60,000
66 lbs. at 2400° F., product	<u>158,400</u>
	218,400

which divided by 166 gives 1370° above atmosphere as the temperature of the chimney gas, or more than enough to make the flue connection and damper red hot. (Makers of boiler compounds, etc., please copy.)

Another writer says: "Scale of  $\frac{1}{16}$  inch thickness will reduce boiler efficiency  $\frac{1}{8}$ , and the reduction of efficiency increases as the square of the thickness of the scale."

This is still more absurd, for according to it if  $\frac{1}{16}$  in. scale reduces the efficiency  $\frac{1}{8}$ , then  $\frac{3}{16}$  in. will reduce it  $\frac{9}{8}$ , or to below zero.

From a series of tests of locomotive tubes covered with different thicknesses of scale up to  $\frac{1}{8}$  in. Prof. E. C. Schmidt (Bull. No. 11 Univ. of Ill. Experiment Station, 1907) draws the following conclusions:

1. Considering scale of ordinary thickness, say varying up to  $\frac{1}{8}$  inch, the loss in heat transmission due to scale may vary in individual cases from insignificant amounts to as much as 10 or 12 per cent.

2. The loss increases somewhat with the thickness of the scale.

3. The mechanical structure of the scale is of as much or more importance than the thickness in producing this loss.

4. Chemical composition, except in so far as it affects the structure of the scale, has no direct influence on its heat-transmitting qualities.

In 1896 the author made a test of a water-tube boiler at Aurora, Ill., which had a coating of scale about  $\frac{1}{4}$  in. thick throughout its whole heating surface, and obtained practically the same evaporation as in another test, a few days later, after the boiler had been cleaned. This is only one case, but the result is not unreasonable when it is known that the scale was very soft and porous, and was easily removed from the tubes by scraping.

Prof. R. C. Carpenter (*Am. Electrician*, Aug., 1900) says: So far as I am able to determine by tests, a lime scale, even of great thickness, has no appreciable effect on the efficiency of a boiler, as in a test which was conducted by myself the results were practically as good when the boiler was thickly covered with lime scale as when perfectly clean. . . . Observations and experiments have shown that any scale porous to water has little or no detrimental effect on economy of the boiler. There is, I think, good philosophy for this statement; the heating capacity is affected principally by the rapidity with which the heated gases will surrender heat, as the water and the metal have capacities for absorbing heat more than a hundred times faster than the air will surrender heat.

A thin film of grease, being impermeable to water, keeps the latter from contact with the metal and generally produces disastrous results. It is much more harmful than a very thick scale of carbonate of lime.

**Boiler-scale Compounds.**—The Bavarian Steam-boiler Inspection Assn. in 1885 reported as follows:

Generally the unusual substances in water can be retained in soluble form or precipitated as mud by adding caustic soda or lime. This is especially desirable when the boilers have small interior spaces.

It is necessary to have a chemical analysis of the water in order to fully determine the kind and quantity of the preparation to be used for the above purpose.

All secret compounds for removing boiler-scale should be avoided. (A list of 27 such compounds manufactured and sold by German firms is then given which have been analyzed by the association.)

Such secret preparations are either nonsensical or fraudulent, or contain either one of the two substances recommended by the association for removing scale, generally soda, which is colored to conceal its presence, and sometimes adulterated with useless or even injurious matter.

These additions as well as giving the compound some strange, fanciful name, are meant simply to deceive the boiler owner and conceal from him the fact that he is buying colored soda or similar substances, for which he is paying an exorbitant price.

**Kerosene and other Petroleum Oils: Foaming.**—Kerosene has been recommended as a scale preventive. See paper by L. F. Lyne

(*Trans. A. S. M. E.*, ix. 247). The *Am. Mach.*, May 22, 1890, says: Kerosene used in moderate quantities will not make the boiler foam; it is recommended and used for loosening the scale and for preventing the formation of scale. The presence of oil in combination with other impurities increases the tendency of many boilers to foam, as the oil with the impurities impedes the free escape of steam from the water surface. The use of common oil not only tends to cause foaming, but is dangerous otherwise. The grease appears to combine with the impurities of the water, and when the boiler is at rest this compound sinks to the plates and clings to them in a loose, spongy mass, preventing the water from coming in contact with the plates, and thereby producing overheating, which may lead to an explosion. Foaming may also be caused by forcing the fire, or by taking the steam from a point over the furnace or where the ebullition is violent; the greasy and dirty state of new boilers is another good cause for foaming. Kerosene should be used at first in small quantities, the effect carefully noted, and the quantity increased if necessary for obtaining the desired results.

R. C. Carpenter (*Trans. A. S. M. E.*, vol. xi) says: The boilers of the State Agricultural College at Lansing, Mich., were badly incrustated with a hard scale. It was fully  $\frac{3}{8}$  in. thick in many places. The first application of the oil was made while the boilers were being but little used, by inserting a gallon of oil, filling with water, heating to the boiling-point and allowing the water to stand in the boiler two or three weeks before removal. By this method fully one-half the scale was removed during the warm season and before the boilers were needed for heavy firing. The oil was then added in small quantities when the boiler was in actual use. For boilers 4 ft. in diam. and 12 ft. long the best results were obtained by the use of 2 qts. for each boiler per week, and for each boiler 5 ft. in diam. 3 qts. per week. The water used in the boilers has the following analysis:  $\text{CaCO}_3$ , 206 parts in a million;  $\text{MgCO}_3$ , 78 parts;  $\text{Fe}_2\text{CO}_3$ , 22 parts; traces of sulphates and chlorides of potash and soda. Total solids, 325 parts in 1,000,000.

**Petroleum Oils** heavier than kerosene have been used with good results. Crude oil should never be used. The more volatile oils it contains make explosive gases, and its tarry constituents are apt to form a spongy incrustation.

**Removal of Hard Scale.** — When boilers are coated with a hard scale difficult to remove the addition of  $\frac{1}{4}$  lb. caustic soda per horse-power, and steaming for some hours, according to the thickness of the scale, just before cleaning, will greatly facilitate that operation, rendering the scale soft and loose. This should be done, if possible, when the boilers are not otherwise in use. (*Steam.*)

**Corrosion in Marine Boilers.** (*Proc. Inst. M. E.*, Aug., 1884.) — The investigations of the Committee on Boilers served to show that the internal corrosion of boilers is greatly due to the combined action of air and sea-water when under steam, and when not under steam to the combined action of air and moisture upon the unprotected surfaces of the metal. There are other deleterious influences at work, such as the corrosive action of fatty acids, the galvanic action of copper and brass, and the inequalities of temperature; these latter, however, are considered to be of minor importance.

Of the several methods recommended for protecting the internal surfaces of boilers, the three found most effectual are: First, the formation of a thin layer of hard scale, deposited by working the boiler with sea-water; second, the coating of the surfaces with a thin wash of Portland cement, particularly wherever there are signs of decay; third, the use of zinc slabs suspended in the water and steam spaces.

As to general treatment for the preservation of boilers when laid up in the reserve, either of the two following methods is adopted. First, the boilers are dried as much as possible by airing-stoves, after which 2 to 3 cwt. of quicklime is placed on trays at the bottom of the boiler and on the tubes. The boiler is then closed and made as air-tight as possible. Inspection is made every six months, when if the lime be found slacked it is renewed. Second, the boilers are filled with sea or fresh water, having added soda to it in the proportion of 1 lb. to every 100 or 120 lbs. of water. The sufficiency of the saturation can be tested by introducing a piece of clean new iron and leaving it in the boiler for ten or twelve

hours: if it shows signs of rusting, more soda should be added. It is essential that the boilers be entirely filled, to the complete exclusion of air.

Mineral oil has for many years been exclusively used for internal lubrication of engines, with the view of avoiding the effects of fatty acid, as this oil does not readily decompose and possesses no acid properties.

Of all the preservative methods adopted in the British service, the use of zinc properly distributed and fixed has been found the most effectual in saving the iron and steel surfaces from corrosion, and also in neutralizing by its own deterioration the hurtful influences met with in water as ordinarily supplied to boilers. The zinc slabs now used in the navy boilers are 12 in. long, 6 in. wide, and  $\frac{1}{2}$  in. thick; this size being found convenient for general application. The amount of zinc used in new boilers at present is one slab of the above size for every 20 I.H.P., or about 1 sq. ft. of zinc surface to 2 sq. ft. of grate surface. Rolled zinc is found the most suitable for the purpose. Especial care must be taken to insure perfect metallic contact between the slabs and the stays or plates to which they are attached. The slabs should be placed in such positions that all the surfaces in the boiler are protected. Each slab should be periodically examined to see that its connection remains perfect, and to renew any that may have decayed; this examination is usually made at intervals not exceeding three months. Under ordinary circumstances of working these zinc slabs may be expected to last in fit condition from 60 to 90 days, immersed in hot sea-water; but in new boilers they at first decay more rapidly. The slabs are generally secured by means of iron straps 2 in.  $\times$   $\frac{3}{8}$  in., and long enough to reach the nearest stay, to which the strap is attached by screw-bolts.

To promote the proper care of boilers when not in use the following order has been issued to the French Navy by the Government: On board all ships in the reserve, as well as those which are laid up, the boilers will be completely filled with fresh water. In the case of large boilers with large tubes there will be added to the water a certain amount of milk of lime, or a solution of soda. In the case of tubulous boilers with small tubes milk of lime or soda may be added, but the solution will not be so strong as in the case of the larger tube, so as to avoid any danger of contracting the effective area by deposit from the solution; but the strength of the solution will be just sufficient to neutralize any acidity of the water. (*Iron Age*, Nov. 2, 1893.)

**Use of Zinc.**—Zinc is often used in boilers to prevent the corrosive action of water on the metal. The action appears to be an electrical one, the iron being one pole of the battery and the zinc being the other. The hydrogen goes to the iron shell and escapes as a gas into the steam. The oxygen goes to the zinc.

On account of this action it is generally believed that zinc will always prevent corrosion, and that it cannot be harmful to the boiler or tank. Some experiences go to disprove this belief, and in numerous cases zinc has not only been of no use, but has even been harmful. In one case a tubular boiler had been troubled with a deposit of scale consisting chiefly of organic matter and lime, and zinc was tried as a preventive. The beneficial action of the zinc was so obvious that its continued use was advised, with frequent opening of the boiler and cleaning out of detached scale until all the old scale should be removed and the boiler become clean. Eight or ten months later the water-supply was changed, it being now obtained from another stream supposed to be free from lime and to contain only organic matter. Two or three months after its introduction the tubes and shell were found to be coated with an obstinate adhesive scale, composed of zinc oxide and the organic matter or sediment of the water used. The deposit had become so heavy in places as to cause overheating and bulging of the plates over the fire. (*The Locomotive*.)

**Effect of Deposit on the Fire-surface of Flues.** (Rankine.)—An external crust of a carbonaceous kind is often deposited from the flame and smoke of the furnaces in the flues and tubes, and if allowed to accumulate, seriously impairs the economy of fuel. It is removed from time to time by means of scrapers and wire brushes. The accumulation of this crust is the probable cause of the fact that in some steamships the consumption of coal per I.H.P. per hour goes on gradually increasing



until it reaches one and a half times its original amount, and sometimes more.

**Dangerous Steam-boilers discovered by Inspection.**—The Hartford Steam-boiler Inspection and Insurance Co. reported in *The Locomotive* the following summary of defects in boilers discovered by its inspectors in the year 1912:

Number of visits of inspection made.....	183,519
Total number of boilers examined.....	337,178
Number found uninsurable.....	977

Nature of Defects	Whole Number	Dangerous
Cases of sediment or loose scale.....	26,299	1,553
Cases of adhering scale.....	40,336	1,436
Cases of grooving.....	2,700	252
Cases of internal corrosion.....	15,403	823
Cases of external corrosion.....	10,411	895
Cases of defective bracing.....	1,391	331
Cases of defective staybolting.....	1,712	345
Settings defective.....	8,119	768
Fractured plates and heads.....	3,288	510
Burned plates.....	4,965	517
Laminated plates.....	445	55
Cases of defective riveting.....	1,816	405
Cases of leakage around tubes.....	10,159	1,607
Cases of defective tubes or flues.....	11,488	4,780
Cases of leakage at seams.....	5,304	401
Water-gages defective.....	3,663	816
Blow-offs defective.....	4,429	1,398
Cases of low water.....	447	151
Safety-valves overloaded.....	1,349	380
Safety-valves defective.....	1,534	419
Pressure-gages defective.....	6,765	568
Boilers without pressure-gages.....	633	102
Miscellaneous defects.....	2,268	420
<b>Total.....</b>	<b>164,924</b>	<b>18,932</b>

The above-named company publishes annually a summary like the above, and also a classified list of boiler-explosions, compiled chiefly from newspaper reports, showing that from 200 to 300 explosions take place in the United States every year, killing from 200 to 300 persons, and injuring from 300 to 450. The lists are not pretended to be complete, and may include only a fraction of the actual number of explosions.

**Steam-boilers as Magazines of Explosive Energy.**—Prof. R. H. Thurston (*Trans. A. S. M. E.*, vol. vi), in a paper with the above title, presents calculations showing the stored energy in the hot water and steam of various boilers. Concerning the plain tubular boiler of average form and dimensions he says: It is 60 in. in diameter, containing 66 3-in. tubes, and is 15 ft. long. It has 850 sq. ft. of heating and 30 sq. ft. of grate surface; is rated at 60 H.P., but is oftener driven up to 75; weighs 9500 lb., and contains nearly its own weight of water, but only 21 lb. of steam when under a pressure of 75 lb. per sq. in., which is below its safe allowance. It stores 52,000,000 foot-pounds of energy, of which but 4% is in the steam, and this is enough to drive the boiler just about one mile into the air, with an initial velocity of nearly 600 ft. per second.

## SAFETY-VALVES.

### Calculation of Weight, etc., for Lever Safety-valves.

Let  $W$  = weight of ball at end of lever;  $w$  = weight of lever itself;  $V$  = weight of valve and spindle, all in pounds;  $L$  = distance between fulcrum and center of ball;  $l$  = distance between fulcrum and center of valve;  $g$  = distance between fulcrum and center of gravity of lever, all in inches;  $A$  = area of valve, in sq. in.;  $P$  = pressure of steam, in lb. per sq. in., at which valve will open.

Then  $PA \times l = W \times L + w \times g + V \times l$ ;  
whence  $P = (WL + wg + Vl) \div Al$ ;  $W = (PA l - wg - Vl) \div L$ ;  $L = (PA l - wg - Vl) \div W$ .

EXAMPLE.—Diameter of valve, 4 in.; distance from fulcrum to center of ball, 36 in.; to center of valve, 4 in.; to center of gravity of lever,  $15\frac{1}{2}$  in.; weight of valve and spindle, 3 lb.; weight of lever, 7 lb.; required the weight of ball to make the blowing-off pressure 80 lb. per sq. in.; area of 4-in. valve = 12.566 sq. in. Then

$$W = \frac{PA l - wg - Vl}{L} = \frac{80 \times 12.566 \times 4 - 7 \times 15\frac{1}{2} - 3 \times 4}{36} = 108.4 \text{ lb.}$$

By the rules of the U. S. Supervising Inspectors of Steam Vessels the use of lever safety-valves is prohibited on all boilers built for steam vessels after June 30, 1906.

A method for calculating the size of safety-valve is given in *The Locomotive*, July, 1892, based on the assumption that the actual opening should be sufficient to discharge all the steam generated by the boiler. Napier's rule for flow of steam is taken, viz., flow through aperture of one sq. in. in lbs. per second = absolute pressure  $\div$  70, or in lbs. per hour =  $51.43 \times$  absolute pressure.

If the angle of the seat is  $45^\circ$ , the area of opening in sq. in. = circumference of the disk  $\times$  the lift  $\times$  0.71, 0.71 being the cosine of  $45^\circ$ ; or diameter of disk  $\times$  lift  $\times$  2.23.

### Spring-loaded Safety-Valves.

Spring-loaded safety-valves to be used on U. S. merchant vessels must conform to the rules prescribed by the Board of Supervising Inspectors, and on vessels for the U. S. Navy to specifications made by the Bureau of Steam Engineering, U. S. N. Valves to be used on stationary boilers must conform in many cases to the special laws made by various states. Few of these rules are on a logical basis, in that they take no account of the lift of the valve, and it is quite clear that the rate of steam discharge through a safety-valve depends upon the area of opening, which varies with the circumference of the valve and the lift. Experiments made by the Consolidated Safety Valve Co. showed that valves made by the different manufacturers and employing various combinations of springs with different designs of valve lips and huddling chambers give widely different lifts. Lifts at popping point of different makes of safety-valves, at 200 lbs. pressure, are as follows:

- 4-in. stationary valves, in., 0.031, 0.056, 0.064, 0.082, 0.094, 0.094, 0.137.  
Av. 0.079 in.  
3 $\frac{1}{2}$ -in. locomotive valves, in., 0.040, 0.051, 0.065, 0.072, 0.076, 0.140 ins.  
Av. 0.074 in.

*United States Supervising Inspectors' Rule* (adopted in 1904).  $A = 0.2074 W/P$ .  $A$  = area of safety valve in sq. in. per sq. ft. of grate surface;  $W$  = lbs. of water evaporated per sq. ft. of grate surface per hour;  $P$  = boiler pressure, absolute, lbs. per sq. in. This rule assumes a lift of  $\frac{1}{32}$  of the nominal diameter, and 75% of the flow calculated by Napier's rule. This 75% corresponds nearly to the cosine of  $45^\circ$ , or 0.707.

*Massachusetts Rule of 1909*.  $A = 770 W/P$ , in which  $W$  = lbs. evaporated per sq. ft. of grate per second;  $A$  and  $P$  as above. This is the same as the U. S. rule with a 3.2% larger constant.

*Philadelphia Rule*. —  $A = 22.5 G \div (P + 8.62)$ .  $A$  = total area of valve or valves, sq. in.;  $G$  = grate area, sq. ft.;  $P$  = boiler pressure (gauge). This rule came from France in 1868. It was recommended to the city of Philadelphia by a committee of the Franklin Institute, although the committee "had not found the reasoning upon which the rule had been based."

Philip G. Darling (*Trans. A. S. M. E.*, 1909) commenting on the above rules says: The principal defect of these rules is that they assume that valves of the same nominal size have the same capacity, and they rate them the same without distinction, in spite of the fact that in actual practice some have but one-third of the capacity of others. There are other defects, such as varying the assumed lift as the valve diameter, while in

reality with a given design the lifts are more nearly the same in the different sizes, not varying nearly as rapidly as the diameters. And further than this, the actual lifts assumed for the larger valves are nearly double the actual average obtained in practice. The direct conclusion is that existing rules and statutes are not safe to follow.

**Rules of the A. S. M. E. Boiler Code Committee.**—In 1914 the Committee had several conferences with the principal safety-valve manufacturers of the country and an agreement was finally reached on the rules given in condensed form below. The discharging capacity of a valve is based on Napier's rule with a coefficient of discharge of 0.96. The formula being  $W = 3600 \times 3.1416 \times D L \times 0.96 \times 0.707 \times P/70$  or  $W = 109.66 D L P$  pounds per hour for a 45° bevel seat valve. For flat seat valves the factor 0.707 is omitted and the formula becomes  $W = 155.11 D L P$  pounds per hour. The following table is calculated from the first formula.

**Discharge Capacities of Direct Spring-Loaded Pop Safety-Valves with 45° Bevel Seats. Pounds per Hour.**

Gage Pres. lb. per sq. in.	Diam. 1 in.			Diam. 1½ in.			Diam. 2 in.			Diam. 2½ in.		
	Lift, in.											
	Min. 0.02	Int. 0.04	Max. 0.05	Min. 0.03	Int. 0.05	Max. 0.06	Min. 0.04	Int. 0.06	Max. 0.07	Min. 0.04	Int. 0.06	Max. 0.08
15	65	131	163	146	245	293	261	391	456	326	488	651
25	87	174	218	196	326	392	349	523	610	435	653	871
50	142	284	354	320	532	639	568	851	994	710	1064	1419
75	197	393	492	443	738	886	787	1181	1377	984	1475	1968
100	252	503	629	566	944	1133	1007	1510	1761	1258	1887	2516
125	307	613	767	689	1149	1379	1224	1836	2145	1532	2299	3064
150	362	723	904	813	1355	1625	1438	2158	2529	1806	2710	3613
175	416	833	1040	936	1561	1872	1664	2497	2913	2081	3121	4161
200	471	941	1178	1060	1766	2119	1884	2826	3296	2354	3532	4709
225	526	1052	1315	1183	1972	2366	2104	3154	3680	2629	3944	5258
250	581	1161	1451	1307	2177	2613	2322	3484	4064	2903	4355	5807
275	635	1271	1589	1430	2383	2860	2542	3813	4448	3177	4766	6355
300	698	1397	1746	3155	2589	3107	2762	4143	4832	3452	5177	6903

**Capacities of Safety-Valves.—Continued.**

Gage Pres. lb. per sq. in.	Diam. 3 in.			Diam. 3½ in.			Diam. 4 in.			Diam. 4½ in.		
	Lift, in.											
	Min. 0.05	Int. 0.08	Max. 0.10	Min. 0.06	Int. 0.09	Max. 0.11	Min. 0.07	Int. 0.10	Max. 0.12	Min. 0.08	Int. 0.11	Max. 0.13
15	489	782	977	684	1026	1254	912	1303	1564	1173	1613	1906
25	653	1046	1307	914	1372	1676	1219	1742	2090	1568	2156	2547
50	1064	1703	2129	1490	2235	2732	1987	2839	3406	2555	3513	4151
75	1475	2361	2951	2066	3099	3788	2754	3935	4722	3542	4870	5756
100	1887	3019	3774	2642	3963	4843	3522	5032	6038	4529	6227	7358
125	2299	3677	4596	3218	4826	5899	4290	6128	7354	5516	7583	8963
150	2710	4335	5419	3794	5690	6954	5058	7226	8670	6503	8940	10566
175	3121	4993	6242	4369	6553	8010	5824	8320	9984	7490	10298	12173
200	3532	5651	7064	4946	7418	9068	6593	9420	11305	8475	11655	13773
225	3944	6310	7890	5521	8280	10120	7361	10514	12616	9465	13013	15383
250	4355	6968	8708	6097	9143	11175	8130	11614	13938	10448	14366	16980
275	4766	7620	9533	6672	10005	12333	8895	12707	15248	11438	15728	18585
300	5177	8280	10358	7248	10875	13290	9668	13807	16568	12428	17088	20195

**Safety-Valve Requirements.**—Each boiler shall have two or more safety-valves, except a boiler for which one safety-valve 3-in. size or smaller is required by these Rules.

The safety-valve capacity for each boiler shall be such that the safety-valve or valves will discharge all the steam that can be generated



by the boiler without allowing the pressure to rise more than 6% above the maximum allowable working pressure, or more than 6% above the highest pressure to which any valve is set.

One or more safety-valves on every boiler shall be set at or below the maximum allowable working pressure. The remaining valves may be set within a range of 3% above the maximum allowable working pressure, but the range of setting of all of the valves on a boiler shall not exceed 10% of the highest pressure to which any valve is set.

Safety-valves shall be of the direct spring-loaded pop type. The vertical lift of the valve disk may be made any amount desired up to a maximum of 0.15 in. The diameter measured at the inner edge of the valve seat shall be not less than 1 in. or more than  $4\frac{1}{2}$  in.

Each safety-valve shall have plainly stamped or cast on the body: (a) The name or trade-mark of the manufacturer. (b) The nominal diameter with the words "Bevel Seat" or "Flat Seat." (c) The steam pressure at which it is set to blow. (d) The lift of the valve disk from its seat, measured immediately after the sudden lift due to the pop. (e) The weight of steam discharged in pounds per hour at the pressure for which it is set to blow.

The minimum capacity of a safety-valve or valves to be placed on a boiler shall be determined on the basis of 6 lb. of steam per hour per sq. ft. of boiler heating surface for water tube boilers, and 5 lb. for all other types of power boilers, and upon the relieving capacity marked on the valves by the manufacturer, provided such marked capacity does not exceed that given in the table, in which case the minimum safety-valve capacity shall be determined on the basis of the maximum relieving capacity given in the table for the particular size of valve and working pressure for which it was constructed. The heating surface shall be computed for that side of the boiler surface exposed to the products of combustion, exclusive of the superheating surface.

Valves  $1\frac{1}{4}$  in. diam. with lifts 0.03, 0.04 and 0.05 in. give a discharge for 0.04-in. lift the same as that of a 1-in. valve with 0.05-in. lift; with 0.03-in. lift 25% less and with 0.05-in. lift 25% greater.

The discharge capacity of a flat seat valve is 1.41 times that of a 45° bevel seat valve of the same diameter and lift.

**Safety-Valves for Locomotives.**—A Committee of the American Railway Master Mechanics Association presented a report on safety-valves in 1912, giving the following formula for 45° bevel seat valves:  $DL P = 0.036 H$ , in which  $D$  = total of the diameters of the inner edge of the seats of the valves required;  $L$  = vertical lift in inches;  $P$  = absolute pressure, lb. per sq. in.;  $H$  = total heating surface of boiler, sq. ft. (superheating surface not included). Every locomotive should be equipped with not less than two and not more than three safety-valves, the size to be determined by the formula. The valves are to be set as follows: The first at boiler pressure, second 2 lb. in excess, third 3 lb. in excess of the second. Manufacturers should be required to stamp on the valve the lift in inches as determined by actual test.

The formula corresponds to the discharge calculated by Napier's rule with a coefficient of flow of 0.973 and an evaporation of 4 lb. per square foot of heating surface per hour. It is evident that safety-valves proportioned according to this formula will have a relieving capacity much less than the evaporative capacity of locomotive boilers with large fire-boxes and short flues. The Consolidated Safety Valve Co. suggests the formula  $DL P = C_1 H_1 + C_2 H_2$  in which  $H_1$  is fire-box and  $H_2$  flue heating-surface, sq. ft., and  $C_1$  and  $C_2$  are constants to be determined by experiment,  $C_1$  being considerably larger than  $C_2$ .

Unequal expansion of safety-valve parts under steam temperatures tends to cause leakage, and as this temperature effect becomes more serious in the large sizes the manufacturers do not recommend the use of valves larger than  $4\frac{1}{2}$  ins. If greater relieving capacity be required it is the best practice to use duplex valves or additional single valves.

For an extended discussion on safety-valves, see *Trans. A. S. M. E.*, 1909.

**THE INJECTOR.**

**Equation of the Injector.**

- Let *S* be the number of pounds of steam used;  
*W* the number of pounds of water lifted and forced into the boiler;  
*h* the height in feet of a column of water, equivalent to the absolute pressure in the boiler;  
*h*<sub>0</sub> the height in feet the water is lifted to the injector;  
*t*<sub>1</sub> the temperature of the water before it enters the injector;  
*t*<sub>2</sub> the temperature of the water after leaving the injector;  
*H* the total heat above 32° F. in one pound of steam in the boiler, in heat-units;  
*L* the work in friction and the equivalent lost work due to radiation and lost heat;  
 778 the mechanical equivalent of heat.

Then

$$S[H - (t_2 - 32^\circ)] = W(t_2 - t_1) + \frac{(W + S)h + Wh_0 + L}{778}$$

An equivalent formula, neglecting *Wh*<sub>0</sub> + *L* as small, is

$$S = \left[ W(t_2 - t_1) + \frac{W + S}{d} \cdot p \cdot \frac{144}{778} \right] \frac{1}{H - (t_2 - 32^\circ)}$$

or  $S = \frac{W[(t_2 - t_1)d + 0.1851 p]}{[H - (t_2 - 32^\circ)]d - 0.1851 p}$

In which *d* = weight of 1 cu. ft. of water at temperature *t*<sub>2</sub>; *p* = absolute pressure of steam, lbs. per sq. in.

The rule for finding the proper sectional area for the narrowest part of the nozzles is given as follows by Rankine, S. E., p. 477:

$$\text{Area in square inches} = \frac{\text{cubic feet per hour gross feed-water}}{800 \sqrt{\text{pressure in atmospheres}}}$$

An important condition which must be fulfilled in order that the injector will work is that the supply of water must be sufficient to condense the steam. As the temperature of the supply or feed-water is higher, the amount of water required for condensing purposes will be greater.

The table below gives the calculated value of the maximum ratio of water to the steam, and the values obtained on actual trial, also the highest admissible temperature of the feed-water as shown by theory and the highest actually found by trial with several injectors.

Gauge-pressure, pounds per sq. in.	Maximum Ratio Water to Steam.			Gauge-pressure, pounds per sq. in.	Maximum Temperature of Feed-Water.						
	Calculated from Theory.	Actual Experiment.			Theoretical.		Experimental Results.				
		H.	P.		M.	Temp. discharge 180°.	Temp. discharge 212°.	H.	P.	M.	S.
10	36.5	30.9	.....	.....	10	.....	.....	.....	.....	.....	132°
20	25.6	22.5	19.9	21.5	20	142°	173°	135°	120°	130°	134
30	20.9	19.0	17.2	19.0	30	132	162	.....	.....	.....	134
40	17.87	15.8	15.0	15.86	40	126	156	140	113	125	132
50	16.2	13.3	14.0	13.3	50	120	150	.....	.....	.....	131
60	14.7	11.2	11.2	12.6	60	114	143	.....	115	123	130
70	13.7	12.3	11.7	12.9	70	109	139	141*	.....	123	130
80	12.9	11.4	11.2	.....	80	105	134	141*	118	122	131
90	12.1	.....	.....	.....	90	99	129	.....	.....	.....	132*
100	11.5	.....	.....	.....	100	95	125	.....	.....	.....	132*
					120	87	117	.....	.....	.....	134*
					150	77	107	.....	.....	.....	121*

\* Temperature of delivery above 212°. Waste-valve closed.

H, Hancock inspirator; P, Park injector; M, Metropolitan injector; S, Sellers 1876 injector.

**Efficiency of the Injector.** — Experiments at Cornell University described by Prof. R. C. Carpenter, in *Cassier's Magazine*, Feb., 1892 show that the injector, when considered merely as a pump, has an exceedingly low efficiency, the duty ranging from 161,000 to 2,752,000 under different circumstances of steam and delivery pressure. Small direct-acting pumps, such as are used for feeding boilers, show a duty of from 4 to 8 million ft.-lbs., and the best pumping-engines from 100 to 140 million. When used for feeding water into a boiler, however, the injector has a thermal efficiency of 100%, less the trifling loss due to radiation, since all the heat rejected passes into the water which is carried into the boiler.

The loss of work in the injector due to friction reappears as heat which is carried into the boiler, and the heat which is converted into useful work in the injector appears in the boiler as stored-up energy.

Although the injector thus has a perfect efficiency as a boiler-feeder, it is not the most economical means for feeding a boiler, since it can draw only cold or moderately warm water, while a pump can feed water which has been heated by exhaust steam which would otherwise be wasted.

**Performance of Injectors.** — In *Am. Mach.*, April 13, 1893, are a number of letters from different manufacturers of injectors in reply to the question: "What is the best performance of the injector in raising or lifting water to any height?" Some of the replies are tabulated below.

W. Sellers & Co. — 25.51 lbs. water delivered to boiler per lb. of steam; temperature of water, 64°; steam pressure, 65 lbs.

Schaeffer & Budenberg — 1 gal. water delivered to boiler for 0.4 to 0.8 lb. steam.

Injector will lift by suction water of

	140° F.	136° to 133°	122° to 118°	113° to 107°
If boiler pres. is 30 to 60 lbs.	60 to 90 lbs.	90 to 120 lbs.	120 to 150 lbs.	

If the water is not over 80° F., the injector will force against a pressure 75 lbs. higher than that of the steam.

Hancock Inspirator Co.:

Lift in feet.....	22	22	22	11
Boiler pressure, absolute, lbs.....	75.8	54.1	95.5	75.4
Temperature of suction... ..	34.9°	35.4°	47.3°	53.2°
Temperature of delivery.....	134°	117.4°	173.7°	131.1°
Water fed per lb. of steam, lbs....	11.02	13.67	8.18	13.3

The theory of the injector is discussed in Wood's, Peabody's, and Rontgen's treatises on Thermodynamics. See also "Theory and Practice of the Injector," by Strickland L. Kneass, New York, 1910.

**Boiler-feeding Pumps.** — Since the direct-acting pump, commonly used for feeding boilers, has a very low efficiency, or less than one-tenth that of a good engine, it is generally better to use a pump driven by belt from the main engine or driving shaft. The mechanical work needed to feed a boiler may be estimated as follows: If the combination of boiler and engine is such that half a cubic foot, say 32 lbs. of water, is needed per horse-power, and the boiler-pressure is 100 lbs. per sq. in., then the work of feeding the quantity of water is 100 lbs. × 144 sq. in. × 1/2 ft.-lb. per hour = 120 ft.-lbs. per min. = 120/33,000 = .0036 H.P., or less than 4/10 of 1% of the power exerted by the engine. If a direct-acting pump, which discharges its exhaust steam into the atmosphere, is used for feeding, and it has only 1/10 the efficiency of the main engine, then the steam used by the pump will be equal to nearly 4% of that generated by the boiler.

The low efficiency of boiler-feeding pumps, and of other small auxiliary steam-driven machinery, is, however, of no importance if all the exhaust steam from these pumps is utilized in heating the feed-water.

The following table by Prof. D. S. Jacobus gives the relative steam consumption of steam and power pumps and injector, with and without heater, as used upon a boiler with 80 lbs. gauge-pressure, the pump having a duty of 10,000,000 ft.-lbs. per 100 lbs. of coal when no heater is used; the injector heating the water from 60° to 150° F.

Direct-acting pump feeding water at 60°, without a heater.....	1.000
Injector feeding water at 150°, without a heater.....	0.985
Injector feeding water through a heater in which it is heated from 150° to 200°.....	0.938



Direct-acting pump feeding water through a heater, in which it is heated from 60° to 200°.....	0.879
Geared pump, run from the engine, feeding water through a heater, in which it is heated from 60° to 200°.....	0.868

**Gravity Boiler-feeders.** — If a closed tank be placed above the level of the water in a boiler and the tank be filled or partly filled with water, then on shutting off the supply to the tank, admitting steam from the boiler to the upper part of the tank, so as to equalize the steam-pressure in the boiler and in the tank, and opening a valve in a pipe leading from the tank to the boiler, the water will run into the boiler. An apparatus of this kind may be made to work with practically perfect efficiency as a boiler-feeder, as an injector does, when the feed-supply is at ordinary atmospheric temperature, since after the tank is emptied of water and the valves in the pipes connecting it with the boiler are closed the condensation of the steam remaining in the tank will create a vacuum which will lift a fresh supply of water into the tank. The only loss of energy in the cycle of operations is the radiation from the tank and pipes, which may be made very small by proper covering.

When the feed-water supply is hot, such as the return water from a heating system, the gravity apparatus may be made to work by having two receivers, one at a low level, which receives the returns or other feed-supply, and the other at a point above the boilers. A partial vacuum being created in the upper tank, steam-pressure is applied above the water in the lower tank by which it is elevated into the upper. The operation of such a machine may be made automatic by suitable arrangement of valves.

**FEED-WATER HEATERS.**

**Percentage of Saving for Each Degree of Increase in Temperature of Feed-water Heated by Waste Steam.**

Initial Temp. of Feed.	Steam Pressure in Boiler, lbs. per sq. in. above Atmosphere.											Initial Temp.
	0	20	40	60	80	100	120	140	160	180	200	
32°	.0872	.0861	.0855	.0851	.0847	.0844	.0841	.0839	.0837	.0835	.0833	32°
40	.0878	.0867	.0861	.0856	.0853	.0850	.0847	.0845	.0843	.0841	.0839	40
50	.0886	.0875	.0868	.0864	.0860	.0857	.0854	.0852	.0850	.0848	.0846	50
60	.0894	.0883	.0876	.0872	.0867	.0864	.0862	.0859	.0856	.0855	.0853	60
70	.0902	.0890	.0884	.0879	.0875	.0872	.0869	.0867	.0864	.0862	.0860	70
80	.0910	.0898	.0891	.0887	.0883	.0879	.0877	.0874	.0872	.0870	.0868	80
90	.0919	.0907	.0900	.0895	.0888	.0887	.0884	.0883	.0879	.0877	.0875	90
100	.0927	.0915	.0908	.0903	.0899	.0895	.0892	.0890	.0887	.0885	.0883	100
110	.0936	.0923	.0916	.0911	.0907	.0903	.0900	.0898	.0895	.0893	.0891	110
120	.0945	.0932	.0925	.0919	.0915	.0911	.0908	.0906	.0903	.0901	.0899	120
130	.0954	.0941	.0934	.0928	.0924	.0920	.0917	.0914	.0912	.0909	.0907	130
140	.0963	.0950	.0943	.0937	.0932	.0929	.0925	.0923	.0920	.0918	.0916	140
150	.0973	.0959	.0951	.0946	.0941	.0937	.0934	.0931	.0929	.0926	.0924	150
160	.0982	.0968	.0961	.0955	.0950	.0946	.0943	.0940	.0937	.0935	.0933	160
170	.0992	.0978	.0970	.0964	.0959	.0955	.0952	.0949	.0946	.0944	.0941	170
180	.1002	.0988	.0981	.0973	.0969	.0965	.0961	.0958	.0955	.0953	.0951	180
190	.1012	.0998	.0989	.0983	.0978	.0974	.0971	.0968	.0964	.0962	.0960	190
200	.1022	.1008	.0999	.0993	.0988	.0984	.0980	.0977	.0974	.0972	.0969	200
210	.1033	.1018	.1009	.1003	.0998	.0994	.0990	.0987	.0984	.0981	.0979	210
220	.....	.1029	.1019	.1013	.1008	.1004	.1000	.0997	.0994	.0991	.0989	220
230	.....	.1039	.1031	.1024	.1018	.1012	.1010	.1007	.1003	.1001	.0999	230
240	.....	.1050	.1041	.1034	.1029	.1024	.1020	.1017	.1014	.1011	.1009	240
250	.....	.1062	.1052	.1045	.1040	.1035	.1031	.1027	.1025	.1022	.1019	250

An approximate rule for the conditions of ordinary practice is that a saving of 1% is made by each increase of 11° in the temperature of the feed-water. This corresponds to 0.0909% per degree.

The calculation of saving is made as follows: Boiler-pressure, 100 lbs. gauge; total heat in steam above 32° = 1185 B.T.U. Feed-water, original temperature 60°, final temperature 209° F. Increase in heat-units, 150.

Heat-units above 32° in feed-water of original temperature = 28. Heat-units in steam above that in cold feed-water, 1185 - 28 = 1157. Saving by the feed-water heater = 150/1157 = 12.96%. The same result is obtained by the use of the table. Increase in temperature 150° × tabular figure 0.0864 = 12.96%. Let total heat of 1 lb. of steam at the boiler-pressure =  $H$ ; total heat of 1 lb. of feed-water before entering the heater =  $h_1$ , and after passing through the heater =  $h_2$ ; then the saving made by the heater is  $\frac{h_2 - h_1}{H - h_1}$ .

**Strains Caused by Cold Feed-water.** — A calculation is made in *The Locomotive* of March, 1893, of the possible strains caused in the section of the shell of a boiler by cooling it by the injection of cold feed-water. Assuming the plate to be cooled 200° F., and the coefficient of expansion of steel to be 0.0000067 per degree, a strip 10 in. long would contract 0.013 in., if it were free to contract. To resist this contraction, assuming that the strip is firmly held at the ends and that the modulus of elasticity is 29,000,000, would require a force of 37,700 lbs. per sq. in. Of course this amount of strain cannot actually take place, since the strip is not firmly held at the ends, but is allowed to contract to some extent by the elasticity of the surrounding metal. But, says *The Locomotive*, we may feel pretty confident that in the case considered a longitudinal strain of somewhere in the neighborhood of 8,000 or 10,000 lbs. per sq. in. may be produced by the feed-water striking directly upon the plates; and this, in addition to the normal strain produced by the steam-pressure, is quite enough to tax the girth-seams beyond their elastic limit, if the feed-pipe discharges anywhere near them. Hence it is not surprising that the girth-seams develop leaks and cracks in 99 cases out of every 100 in which the feed discharges directly upon the fire-sheets.

**Capacity of Feed-water Heaters.** (W. R. Billings, *Eng. Rec.*, Feb., 1898.) — Closed feed-water heaters are seldom provided with sufficient surface to raise the feed temperature to more than 200°. The rate of heat transmission may be measured by the number of British thermal units which pass through a square foot of tubular surface in one hour for each degree of difference in temperature between the water and the steam. One set of experiments gave results as below:

Difference between final temperatures of water and steam	}	5° F. ....	67 B.T.U.	}	Transmitted in one hour by each sq. ft. of surface for each degree of average difference in temper- atures.
		6° " .....	79 "		
		8° " .....	89 "		
		11° " .....	114 "		
		15° " .....	129 "		
		18° " .....	139 "		

Even with the rate of transmission as low as 67 B.T.U. the water was still 5° from the temperature of the steam. At what rate would the heat have been transmitted if the water could have been brought to within 2° of the temperature of the steam, or to 210° when the steam is at 212°?

For commercial purposes feed-water heaters are given a H.P. rating which allows about one-third of a square foot of surface per H.P. — a boiler H.P. being 30 lbs. of water per hour. If the figures given in the table above are accepted as substantially correct, a heater which is to raise 3000 lbs. of water per hour from 60° to 207°, using exhaust steam at 212° as a heating medium, should have nearly 84 sq. ft. of heating surface or nearly a square foot of surface per H.P. That feed-water heaters do not carry this amount of heating surface is well known.

**Calculation of Surface of Heaters and Condensers.** — (H. L. Hepburn, *Power*, April, 1902.) Let  $W$  = lbs. of water per hour;  $A$  = area of surface in sq. ft.;  $T_s$  = temperature of the steam;  $I$  = initial temperature of the water;  $F$  = final temperature of the water;  $S$  = lbs. of steam per hour;  $H$  = B.T.U. above 32° F. in 1 lb. of steam;  $N$  = B.T.U. in 1 lb. of condensed steam;  $U$  = B.T.U. transmitted per sq. ft. per hr. per deg. of mean difference of temperature between the steam and the water.

Then  $AU = W \log_e \frac{T_s - I}{T_s - F}$ , for heaters.

$AU = S \frac{H - N}{F - I} \times \log_e \frac{T_s - I}{T_s - F}$ , for condensers.

The value of  $U$  varies widely according to the condition of the surface whether clean or coated with grease or scale, and also with the velocity of the water over the surfaces. Values of 300 to 350 have been obtained in experiments with corrugated copper tubes, but ordinary heaters give much lower values. From the experiments of Loring and Emery on the U. S. S. *Dallas*, Mr. Hepburn finds  $U = 192$ . Using this value he finds the number of square feet of heating surface required per 1000 lbs. of feed-water per hour to be as follows, the temperature of the entering water being 60° F.

Steam Temperature, 212°.				Steam 25 in. Vacuum.			
$F$	$S$	$F$	$S$	$F$	$S$	$F$	$S$
194	11.11	204	15.34	90	2.38	115	6.78
196	11.73	206	16.85	95	3.03	120	8.60
198	12.44	208	18.93	100	3.76	125	11.15
200	13.20	210	22.52	105	4.62	130	16.25
202	14.17	212	Infinite	110	5.65	133	Infinite

$F$  = final temperature of feed-water,  $S$  = sq. ft. of surface. From this table it is seen that if 30 lbs. of water per hour is taken to equal 1 H.P. and a feed-water heater is made with  $\frac{1}{3}$  sq. ft. per H.P., it may be expected to heat the feed-water from 60° to something less than 194°, or if made with  $\frac{1}{2}$  sq. ft. per H.P. it may heat the water to 204° F.

For a further discussion of this subject, see Heat, pages 587 to 591.

**Proportions of Open Type Feed-water Heaters.** — C. L. Hubbard (*Practical Engineer*, Jan. 1, 1909) gives the following:

Exhaust heaters should be proportioned according to the quality of the water to be used, the size being increased with the amount of mud or scale-producing properties which the water contains regardless of the quantity of water to be heated. The general proportions of an open heater will depend somewhat upon the arrangement of the trays or pans, but an approximation of the size of shell for a cylindrical heater is as follows:  $A = H \div aL$ ;  $L = H \div aA$ ; in which  $A$  = sectional area of shell in sq. ft.;  $L$  = length of shell in linear ft.;  $H$  = total weight of water to be heated per hour divided by the weight of steam used per horse-power per hour by the engine;  $a = 2.15$  for very muddy water, 6.0 for slightly muddy water, and 8.0 for clear water.

The pan or tray surface varies according to the quality of the water, both as regards the amount of mud and the scale-making ingredients. The surface in square feet for each 1000 lbs. of water heated per hour may be taken as follows, for the vertical and horizontal types respectively:

Very bad water.....	8.5 and 9.1
Medium muddy water.....	6 and 6.5
Clear and little scale.....	2 and 2.2

The space between the pans is made not less than 0.1 the width for rectangular and 0.25 the diameter for round pans. Under ordinary circumstances it is not customary to use more than six pans in a tier, in order to obtain a low velocity over each pan. The size of the storage or settling chamber in the horizontal type varies from 0.25 to 0.4 of the volume of the shell, depending on the quality of the water; 0.33 is about the average. In the case of vertical heaters, this varies from 0.4 to 0.6 of the volume of the shell. Filters occupy from 10 to 15% of the volume of the shell in the horizontal type and from 15 to 20% in the vertical.

**Open versus Closed Feed-water Heaters.** (W. E. Harrington, *St. Rwy. Jour.*, July 22, 1905.) — There still exists some difference of opinion as to the relative desirability of open or closed type of feed-water heater, but the degree of perfection which the open heater has attained has eliminated formerly objectionable features. The chief objection which attended the early use of the open heater, namely, that the oil from the exhaust steam was carried into the boiler, did much to discourage its more general adoption. This objection does not hold good against the better designs of open heaters now on the market. There are thousands of installations in which the open heater is now being used where no difficulty is experienced from the contamination of the feed-water by oil. The perfection of oil separators for use in the exhaust steam connection to the heater has rendered this possible.



**STEAM SEPARATORS.**

If moist steam flowing at a high velocity in a pipe has its direction suddenly changed, the particles of water are by their momentum projected in their original direction against the bend in the pipe or wall of the chamber in which the change of direction takes place. By making proper provision for drawing off the water thus separated the steam may be dried to a greater or less extent. For long steam-pipes a large drum should be provided near the engine for trapping the water condensed in the pipe. A drum 3 ft. diameter, 15 ft. high, has given good results in separating the water of condensation of a steam-pipe 10 in. diameter and 800 ft. long.

**Efficiency of Steam Separators.**—Prof. R. C. Carpenter, in 1891, made a series of tests of six steam separators, furnishing them with steam containing different percentages of moisture, and testing the quality of steam before entering and after passing the separator. A condensed table of the principal results is given below.

Make of Separator.	Test with Steam of about 10% of Moisture.			Tests with Varying Moisture.		
	Quality of Steam before.	Quality of Steam after.	Efficiency, per cent.	Quality of Steam before.	Quality of Steam after.	Av'ge Efficiency.
B	87.0%	98.8%	90.8	66.1 to 97.5%	97.8 to 99%	87.6
A	90.1	98.0	80.0	51.9 " 98	97.9 " 99.1	76.4
D	89.6	95.8	59.6	72.2 " 96.1	95.5 " 98.2	71.7
C	90.6	93.7	33.0	67.1 " 96.8	93.7 " 98.4	63.4
E	88.4	90.2	15.5	68.6 " 98.1	79.3 " 98.5	36.9
F	88.9	92.1	28.8	70.4 " 97.7	84.1 " 97.9	28.4

Conclusions from the tests were: 1. That no relation existed between the volume of the several separators and their efficiency. 2. No marked decrease in pressure was shown by any of the separators, the most being 1.7 lbs. in E. 3. Although changed direction, reduced velocity, and perhaps centrifugal force are necessary for good separation, still some means must be provided to lead the water out of the current of the steam. The high efficiency obtained from B and A was largely due to this feature. In B the interior surfaces are corrugated and thus catch the water thrown out of the steam and readily lead it to the bottom. In A, as so on as the water falls or is precipitated from the steam, it comes in contact with the perforated diaphragm through which it runs into the space below, where it is not subjected to the action of the steam. Experiments made by Prof. Carpenter on a "Stratton" separator in 1894 showed that the moisture in the steam leaving the separator was less than 1% when that in the steam supplied ranged from 6% to 21%.

Experiments by Prof. G. F. Gebhardt (*Power*, May 11, 1909) on six separators of different makes led to the following conclusions: (1) The efficiency of separation decreases as the velocity of the steam increases. (2) The efficiency increases as the percentage of moisture in the entering steam increases. (3) The drop in pressure increases rapidly with the increase in velocity. The six separators are described as follows:

U: 2-in. vertical; no baffles; current reversed once.

V: 4-in. horizontal with single baffle plate of the fluted type; current reversed once.

W: 4-in. vertical with two baffle plates of the smooth type; current reversed once.

X: 3-in. horizontal; several fluted baffle plates; no reversal of current.

Y: 6-in. vertical; centrifugal type; current reversed once.

Z: 3-in. horizontal; current reversed twice; steam impinges on horizontal fluted baffle during reversal.

The efficiency is defined as the ratio of the water removed from the steam by the separator to the water injected into the dry steam for the purpose of the test. With steam at 100 lbs. pressure containing 10% water, the efficiencies, taken from plotted curves, were as follows:

	U	V	W	X	Y	Z
At 2000 ft. per min.....	64	69	86	88	79	66
At 3000 ft. per min.....	37	45	80	60	61	48

### DETERMINATION OF THE MOISTURE IN STEAM—STEAM CALORIMETERS.

In all boiler-tests it is important to ascertain the quality of the steam, i.e., 1st, whether the steam is "saturated" or contains the quantity of heat due to the pressure according to standard experiments; 2d, whether the quantity of heat is deficient, so that the steam is wet; and 3d, whether the heat is in excess and the steam superheated. The best method of ascertaining the quality of the steam is undoubtedly that employed by a committee which tested the boilers at the American Institute Exhibition of 1871-2, of which Prof. Thurston was chairman, i.e., condensing all the water evaporated by the boiler by means of a surface condenser, weighing the condensing water, and taking its temperature as it enters and as it leaves the condenser; but this plan cannot always be adopted.

A substitute for this method is the barrel calorimeter, which with careful operation and fairly accurate instruments may generally be relied on to give results within two per cent of accuracy (that is, a sample of steam which gives the apparent result of 2% of moisture may contain anywhere between 0 and 4%). This calorimeter is described as follows: A sample of the steam is taken by inserting a perforated 1/2-inch pipe into and through the main pipe near the boiler, and led by a hose, thoroughly felted, to a barrel, holding preferably 400 lbs. of water, which is set upon a platform scale and provided with a cock or valve for allowing the water to flow to waste, and with a small propeller for stirring the water.

To operate the calorimeter the barrel is filled with water, the weight and temperature ascertained, steam blown through the hose outside the barrel until the pipe is thoroughly warmed, when the hose is suddenly thrust into the water, and the propeller operated until the temperature of the water is increased to the desired point, say about 110° usually. The hose is then withdrawn quickly, the temperature noted, and the weight again taken.

An error of 1/10 of a pound in weighing the condensed steam, or an error of 1/2 degree in the temperature, will cause an error of over 1% in the calculated percentage of moisture. See *Trans. A. S. M. E.*, vi, 293.

The calculation of the percentage of moisture is made as below:

$$Q = \frac{1}{H - T} \left[ \frac{W}{w} (h_1 - h) - (T - h_1) \right]$$

$Q$  = quality of the steam, dry saturated steam being unity.

$H$  = total heat of 1 lb. of steam at the observed pressure.

$T$  = total heat of 1 lb. of water at the temperature of steam of the observed pressure.

$h$  = total heat of 1 lb. of condensing water, original.

$h_1$  = total heat of 1 lb. of condensing water, final.

$W$  = weight of condensing water, corrected for water-equivalent of the apparatus.

$w$  = weight of the steam condensed.

Percentage of moisture =  $1 - Q$ .

If  $Q$  is greater than unity, the steam is superheated, and the degrees of superheating =  $2.0833 (H - T) (Q - 1)$ .

**Difficulty of Obtaining a Correct Sample.** — Experiments by Prof. D. S. Jacobus (*Trans. A. S. M. E.*, xvi, 1017), show that it is practically impossible to obtain a true average sample of the steam flowing in a pipe. For accurate determinations all the steam made by the boiler should be passed through a separator, the water separated should be weighed and a calorimeter test made of the steam just after it has passed the separator.

**Coil Calorimeters.** — Instead of the open barrel in which the steam is condensed, a coil acting as a surface-condenser may be used, which is placed in the barrel, the water in coil and barrel being weighed separately. For a description of an apparatus of this kind designed by the author, which he has found to give results with a probable error not exceeding 1/2 per cent of moisture, see *Trans. A. S. M. E.*, vi, 294. This calorimeter may be used continuously, if desired, instead of intermittently. In this case a continuous flow of condensing water into and out of the barrel must be established, and the temperature of inflow and outflow and of the condensed steam read at short intervals of time.

**Throttling Calorimeter.**—For percentages of moisture not exceeding 3 per cent the throttling calorimeter is most useful and convenient and remarkably accurate. In this instrument the steam which reaches it in a 1/2-inch pipe is throttled by an orifice 1/16 inch diameter, opening into a chamber which has an outlet to the atmosphere. The steam in this chamber has its pressure reduced nearly or quite to the pressure of the atmosphere, but the total heat in the steam before throttling causes the steam in the chamber to be superheated more or less according to whether the steam before throttling was dry or contained moisture. The only observations required are those of the temperature and pressure of the steam on each side of the orifice.

The author's formula for reducing the observations of the throttling calorimeter is as follows (Experiments on Throttling Calorimeters, *Am. Mach.*, Aug. 4, 1892):

$$w = 100 \times \frac{H - h - K(T - t)}{L}$$

in which  $w$  = percentage of moisture in the steam;  $H$  = total heat, and  $L$  = latent heat of steam in the main pipe;  $h$  = total heat due the pressure in the discharge side of the calorimeter, = 1150.4 at atmospheric pressure;  $K$  = specific heat of superheated steam;  $T$  = temperature of the throttled and superheated steam in the calorimeter;  $t$  = temperature due to the pressure in the calorimeter, = 212° at atmospheric pressure.

Taking  $K$  at 0.46 and the pressure in the discharge side of the calorimeter as atmospheric pressure, the formula becomes

$$w = 100 \times \frac{H - 1150.4 - 0.46(T - 212^\circ)}{L}$$

From this formula the following table is calculated:

MOISTURE IN STEAM—DETERMINATIONS BY THROTTLING CALORIMETER.

Degree of Super-heating $T - 212^\circ$ .	Gauge-pressures.											
	5	10	20	30	40	50	60	70	75	80	85	90
	Per Cent of Moisture in Steam.											
0°	0.51	0.90	1.54	2.06	2.50	2.90	3.24	3.56	3.71	3.86	3.99	4.13
10°	0.01	0.39	1.02	1.54	1.97	2.36	2.71	3.02	3.17	3.32	3.45	3.58
20°	.....	.....	0.51	1.02	1.45	1.83	2.17	2.48	2.63	2.77	2.90	3.03
30°	.....	.....	0.00	0.50	0.92	1.30	1.64	1.94	2.09	2.23	2.35	2.49
40°	.....	.....	.....	.....	0.39	0.77	1.10	1.40	1.55	1.69	1.80	1.94
50°	.....	.....	.....	.....	.....	0.24	0.57	0.87	1.01	1.15	1.26	1.40
60°	.....	.....	.....	.....	.....	.....	0.03	0.33	0.47	0.60	0.72	0.85
70°	.....	.....	.....	.....	.....	.....	.....	.....	.....	0.06	0.17	0.31
Dif. p. deg...	.0503	.0507	.0515	.0521	.0526	.0531	.0535	.0539	.0541	.0542	.0544	.0546

Degree of Super-heating $T - 212^\circ$ .	Gauge-pressures.											
	100	110	120	130	140	150	160	170	180	190	200	250
	Per Cent of Moisture in Steam.											
0°	4.39	4.63	4.85	5.08	5.29	5.49	5.68	5.87	6.05	6.22	6.39	7.16
10°	3.84	4.08	4.29	4.52	4.73	4.93	5.12	5.30	5.48	5.65	5.82	6.58
20°	3.29	3.52	3.74	3.96	4.17	4.37	4.56	4.74	4.91	5.08	5.25	6.00
30°	2.74	2.97	3.18	3.41	3.61	3.80	3.99	4.17	4.34	4.51	4.67	5.41
40°	2.19	2.42	2.63	2.85	3.05	3.24	3.43	3.61	3.78	3.94	4.10	4.83
50°	1.64	1.87	2.08	2.29	2.49	2.68	2.87	3.04	3.21	3.37	3.53	4.25
60°	1.09	1.32	1.52	1.74	1.93	2.12	2.30	2.48	2.64	2.80	2.96	3.67
70°	0.55	0.77	0.97	1.18	1.38	1.56	1.74	1.91	2.07	2.23	2.38	3.09
80°	0.00	0.22	0.42	0.63	0.82	1.00	1.18	1.34	1.50	1.66	1.81	2.51
90°	.....	.....	.....	0.07	0.26	0.44	0.61	0.78	0.94	1.09	1.24	1.93
100°	.....	.....	.....	.....	.....	.....	0.05	0.21	0.37	0.52	0.67	1.34
110°	.....	.....	.....	.....	.....	.....	.....	.....	.....	.....	0.10	0.76
Dif. p. deg...	.0549	.0551	.0554	.0556	.0559	.0561	.0564	.0566	.0568	.0570	.0572	.0581

**Separating Calorimeters.**—For percentages of moisture beyond the range of the throttling calorimeter the separating calorimeter is used,



which is simply a steam separator on a small scale. An improved form of this calorimeter is described by Prof. Carpenter in *Power*, Feb., 1893.

For fuller information on various kinds of calorimeters, see papers by Prof. Peabody, Prof. Carpenter, and Mr. Barrus in *Trans. A. S. M. E.*, vols. x, xi, xii, 1889 to 1891; Appendix to Report of Com. on Boiler Tests, *A. S. M. E.*, vol. vi, 1884; Circular of Schaeffer & Budenberg, N. Y., "Calorimeters, Throttling and Separating."

**Identification of Dry Steam by Appearance of a Jet.** — Prof. Denton (*Trans. A. S. M. E.*, vol. x) found that jets of steam show unmistakable change of appearance to the eye when steam varies less than 1% from the condition of saturation in the direction of either wetness or of superheating.

If a jet of steam flow from a boiler into the atmosphere under circumstances such that very little loss of heat occurs through radiation, etc., and the jet be transparent close to the orifice, or be even a grayish-white color, the steam may be assumed to be so nearly dry that no portable condensing calorimeter will be capable of measuring the amount of water in the steam. If the jet be strongly white, the amount of water may be roughly judged up to about 2%, but beyond this only a calorimeter can determine the exact amount of moisture.

A common brass pet-cock may be used as an orifice, but it should, if possible, be set into the steam-drum of the boiler and never be placed further away from the latter than 4 feet, and then only when the intermediate reservoir or pipe is well covered.

**Usual Amount of Moisture in Steam Escaping from a Boiler.** — In the common forms of horizontal tubular land boilers and water-tube boilers with ample horizontal drums, and supplied with water free from substances likely to cause foaming, the moisture in the steam does not generally exceed 2% unless the boiler is overdriven or the water-level is carried too high.

## CHIMNEYS.

**Chimney Draught Theory.** — The commonly accepted theory of chimney draught, based on Peclet's and Rankine's hypotheses (Rankine, S. E.), is discussed by Prof. De Volson Wood, *Trans. A. S. M. E.*, vol. xi.

Peclet represented the law of draught by the formula

$$h = \frac{u^2}{2g} \left( 1 + G + \frac{fl}{m} \right)$$

in which  $h$  is the "head," defined as such a height of hot gases as, if added to the column of gases in the chimney, would produce the same pressure at the furnace as a column of outside air, of the same area of base, and a height equal to that of the chimney;

$u$  is the required velocity of gases in the chimney;

$G$  a constant to represent the resistance to the passage of air through the coal;

$l$  the length of the flues and chimney;

$m$  the mean hydraulic depth or the area of a cross-section divided by the perimeter;

$f$  a constant depending upon the nature of the surfaces over which the gases pass, whether smooth, or sooty and rough.

Rankine's formula (*Steam Engine*, p. 288), derived by giving certain values to the constants (so-called) in Peclet's formula, is

$$h = \frac{\tau_0}{\tau_2} (0.0807) H - H = \left( 0.96 \frac{\tau_1}{\tau_2} - 1 \right) H;$$

$$\frac{\tau_0}{\tau_1} (0.084)$$

in which  $H$  = the height of the chimney in feet;

$\tau_0$  = 493° F., absolute (temperature of melting ice);

$\tau_1$  = absolute temperature of the gases in the chimney;

$\tau_2$  = absolute temperature of the external air.

Prof. Wood derives from this a still more complex formula which gives the height of chimney required for burning a given quantity of coal per second, and from it he calculates the following table, showing the height of chimney required to burn respectively 24, 20, and 16 lbs. of coal per square foot of grate per hour, for the several temperatures of the chimney gases given.

Outside Air. $\tau_2$ .	Chimney Gas.		Coal per sq. ft. of grate per hour, lbs.		
	$\tau_1$ Absolute.	Temp. Fahr.	24	20	16
			Height $H$ , feet.		
520°	700	239	250.9	157.6	67.8
absolute or	800	339	172.4	115.8	55.7
59° F.	1000	539	149.1	100.0	48.7
	1100	639	148.8	98.9	48.2
	1200	739	152.0	100.9	49.1
	1400	939	159.9	105.7	51.2
	1600	1139	168.8	111.0	53.5
	2000	1539	206.5	132.2	63.0

Rankine's formula gives a maximum draught when  $\tau = 2\frac{1}{2} \tau_2$ , or 622° F., when the outside temperature is 60°. Prof. Wood says: "This result is not a fixed value, but departures from theory in practice do not affect the result largely. There is, then, in a properly constructed chimney properly working, a temperature giving a maximum draught,\* and that temperature is not far from the value given by Rankine, although in special cases it may be 50° or 75° more or less."

All attempts to base a practical formula for chimneys upon the theoretical formula of Peclet and Rankine have failed on account of the impossibility of assigning correct values to the so-called "constants"  $G$  and  $f$ . (See *Trans. A. S. M. E.*, xi, 984.)

**Force or Intensity of Draught.** — The force of the draught is equal to the difference between the weight of the column of hot gases inside of the chimney and the weight of a column of the external air of the same height. It is measured by a draught-gauge, usually a U-tube partly filled with water, one leg connected by a pipe to the interior of the flue, and the other open to the external air.

If  $D$  is the density of the air outside,  $d$  the density of the hot gas inside, in lbs. per cubic foot,  $h$  the height of the chimney in feet, and 0.192 the factor for converting pressure in lbs. per sq. ft. into inches of water column, then the formula for the force of draught expressed in inches of water is,

$$F = 0.192 h (D - d).$$

The density varies with the absolute temperature (see Rankine).

$$d = \frac{\tau_0}{\tau_1} 0.084; D = 0.0807 \frac{\tau_0}{\tau_2},$$

where  $\tau_0$  is the absolute temperature at 32° F., = 493,  $\tau_1$  the absolute temperature of the chimney gases and  $\tau_2$  that of the external air. Substituting these values the formula for force of draught becomes

$$F = 0.192 h \left( \frac{39.79}{\tau_2} - \frac{41.41}{\tau_1} \right) = h \left( \frac{7.64}{\tau_2} - \frac{7.95}{\tau_1} \right).$$

\* Much confusion to students of the theory of chimneys has resulted from their understanding the words maximum draught to mean maximum intensity or pressure of draught, as measured by a draught-gauge. It here means maximum quantity or weight of gases passed up the chimney. The maximum intensity is found only with maximum temperature, but after the temperature reaches about 622° F. the density of the gas decreases more rapidly than its velocity increases, so that the weight is a maximum about 622° F., as shown by Rankine. — W. K.

To find the maximum intensity of draught for any given chimney, the heated column being 600° F., and the external air 60°, multiply the height above grate in feet by 0.0073, and the product is the draught in inches of water.

### Height of Water Column Due to Unbalanced Pressure in Chimney 100 Feet High. (*The Locomotive*, 1884.)

Temp. in the Chimney.	Temperature of the External Air — Barometer, 14.7 lbs. per sq. in.										
	0°	10°	20°	30°	40°	50°	60°	70°	80°	90°	100°
200	0.453	0.419	0.384	0.353	0.321	0.292	0.263	0.234	0.209	0.182	0.157
220	.488	.453	.419	.388	.355	.326	.298	.269	.244	.217	.192
240	.520	.488	.451	.421	.388	.359	.330	.301	.276	.250	.225
260	.555	.528	.484	.453	.420	.392	.363	.334	.309	.282	.257
280	.584	.549	.515	.482	.451	.422	.394	.365	.340	.313	.288
300	.611	.576	.541	.511	.478	.449	.420	.392	.367	.340	.315
320	.637	.603	.568	.538	.505	.476	.447	.419	.394	.367	.342
340	.662	.638	.593	.563	.530	.501	.472	.443	.419	.392	.367
360	.687	.653	.618	.588	.555	.526	.497	.468	.444	.417	.392
380	.710	.676	.641	.611	.578	.549	.520	.492	.467	.440	.415
400	.732	.697	.662	.632	.598	.570	.541	.513	.488	.461	.436
420	.753	.718	.684	.653	.620	.591	.563	.534	.509	.482	.457
440	.774	.739	.705	.674	.641	.612	.584	.555	.530	.503	.478
460	.793	.758	.724	.694	.660	.632	.603	.574	.549	.522	.497
480	.810	.776	.741	.710	.678	.649	.620	.591	.566	.540	.515
500	.829	.791	.760	.730	.697	.669	.639	.610	.586	.559	.534

For any other height of chimney than 100 ft. the height of water column is found by simple proportion, the height of water column being directly proportioned to the height of chimney.

The calculations have been made for a chimney 100 ft. high, with various temperatures outside and inside of the flue, and on the supposition that the temperature of the chimney is uniform from top to bottom. This is the basis on which all calculations respecting the draught-power of chimneys have been made by Rankine and other writers, but it is very far from the truth in most cases. The difference will be shown by comparing the reading of the draught-gauge with the table given. In one case a chimney 122 ft. high showed a temperature at the base of 320°, and at the top of 230°.

Box, in his "Treatise on Heat," gives the following table:

### DRAUGHT POWERS OF CHIMNEYS, ETC., WITH THE INTERNAL AIR AT 552° AND THE EXTERNAL AIR AT 62°, AND WITH THE DAMPER NEARLY CLOSED.

Height of Chimney in feet.	Draught Power in ins. of water.	Theoretical Velocity in feet per second.		Height of Chimney in feet.	Draught Power in ins. of water.	Theoretical Velocity in feet per second.	
		Cold Air Entering.	Hot Air at Exit.			Cold Air Entering.	Hot Air at Exit.
10	0.073	17.8	35.6	80	0.585	50.6	101.2
20	0.146	25.3	50.6	90	0.657	53.7	107.4
30	0.219	31.0	62.0	100	0.730	56.5	113.0
40	0.292	35.7	71.4	120	0.876	62.0	124.0
50	0.365	40.0	80.0	150	1.095	69.3	138.6
60	0.438	43.8	87.6	175	1.277	74.3	149.6
70	0.511	47.3	94.6	200	1.460	80.0	160.0



**Rate of Combustion Due to Height of Chimney.** — Trowbridge's "Heat and Heat Engines" gives the following figures for the heights of chimney for producing certain rates of combustion per sq. ft. of grate. They may be approximately true for anthracite in moderate and large sizes, but greater heights than are given in the table are needed to secure the given rates of combustion with small sizes of anthracite, and for bituminous coal smaller heights will suffice if the coal is reasonably free from ash — 5% or less.

Height, feet.	Lbs. of Coal per Sq. Ft. of Grate.	Height, feet.	Lbs. of Coal per Sq. Ft. of Grate.	Height, feet.	Lbs. of Coal per Sq. Ft. of Grate.	Height, feet.	Lbs. of Coal per Sq. Ft. of Grate.
20	7.5	45	12.4	70	15.8	95	18.5
25	8.5	50	13.1	75	16.4	100	19.0
30	9.5	55	13.8	80	16.9	105	19.5
35	10.5	60	14.5	85	17.4	110	20.0
40	11.6	65	15.1	90	18.0	.....	.....

W. D. Ennis (*Eng. Mag.*, Nov., 1907), gives the following as the force of draught required for burning No. 1 buckwheat coal:

Draught, in. of water .....	0.3	0.45	0.7	1.0
Lbs. coal per sq. ft. grate per hour.....	10	15	20	25

Thurston's rule for rate of combustion effected by a given height of chimney (*Trans. A. S. M. E.*, xi, 991) is: Subtract 1 from twice the square root of the height, and the result is the rate of combustion in pounds per square foot of grate per hour, for anthracite. Or rate =  $2\sqrt{h} - 1$ , in which  $h$  is the height in feet. This rule gives the following:

$h = 50$	60	70	80	90	100	110	125	150	175	200
$2\sqrt{h} - 1 = 13.14$	14.49	15.73	16.89	17.97	19	19.97	21.36	23.49	25.45	27.28

The results agree closely with Trowbridge's table given above. In practice the high rates of combustion for high chimneys given by the formula are not generally obtained, for the reason that with high chimneys there are usually long horizontal flues, serving many boilers, and the friction and the interference of currents from the several boilers are apt to cause the intensity of draught in the branch flues leading to each boiler to be much less than that at the base of the chimney. The draught of each boiler is also usually restricted by a damper and by bends in the gas-passages. In a battery of several boilers connected to a chimney 150 ft. high, the author found a draught of 3/4-inch water-column at the boiler nearest the chimney, and only 1/4-inch at the boiler farthest away. The first boiler was wasting fuel from too high temperature of the chimney-gases, 900°, having too large a grate-surface for the draught, and the last boiler was working below its rated capacity and with poor economy, on account of insufficient draught.

The effect of changing the length of the flue leading into a chimney 60 ft. high and 2 ft. 9 in. square is given in the following table, from Box on "Heat":

Length of Flue in feet.	Horse-power.	Length of Flue in feet.	Horse-power.
50	107.6	800	56.1
100	100.0	1,000	51.4
200	85.3	1,500	43.3
400	70.8	2,000	38.2
600	62.5	3,000	31.7

The temperature of the gases in this chimney was assumed to be 552° F., and that of the atmosphere 62°.

**High Chimneys not Necessary.** — Chimneys above 150 ft. in height are very costly, and their increased cost is rarely justified by increased efficiency. In recent practice it has become somewhat common to build two or more smaller chimneys instead of one large one. A notable example is the Spreckels Sugar Refinery in Philadelphia, where three separate chimneys are used for one boiler-plant of 7500 H.P. The three chimneys are said to have cost several thousand dollars less than a single chimney of their combined capacity would have cost. Very tall chimneys have been characterized by one writer as "monuments to the folly of their builders."

**Heights of Chimney required for Different Fuels.** — The minimum height necessary varies with the fuel, wood requiring the least, then good bituminous coal, and fine sizes of anthracite the greatest. It also varies with the character of the boiler — the smaller and more circuitous the gas-passages the higher the stack required; also with the number of boilers, a single boiler requiring less height than several that discharge into a horizontal flue. No general rule can be given.

C. L. Hubbard (*Am. Electrician*, Mar., 1904) says: The following heights have been found to give good results in plants of moderate size, and to produce sufficient draught to force the boilers from 20 to 30 per cent above their rating:

With free-burning bituminous coal, 75 feet; with anthracite of medium and large size, 100 feet; with slow-burning bituminous coal, 120 feet; with anthracite pea coal, 130 feet; with anthracite buckwheat coal, 150 feet. For plants of 700 or 800 horse-power and over, the chimney should not be less than 150 feet high regardless of the kind of coal to be used.

### SIZE OF CHIMNEYS.

The formula given below, and the table calculated therefrom for chimneys up to 96 in. diameter and 200 ft. high, were first published by the author in 1884 (*Trans. A. S. M. E.*, vi, 81). They have met with much approval since that date by engineers who have used them, and have been frequently published in boiler-makers' catalogues and elsewhere. The table is now extended to cover chimneys up to 12 ft. diameter and 300 ft. high. The sizes corresponding to the given commercial horse-powers are believed to be ample for all cases in which the draught areas through the boiler-flues and connections are sufficient, say not less than 20% greater than the area of the chimney, and in which the draught between the boilers and chimney is not checked by long horizontal passages and right-angled bends.

*Note that the figures in the table correspond to a coal consumption of 5 lbs. of coal per horse-power per hour.* This liberal allowance is made to cover the contingencies of poor coal being used, and of the boilers being driven beyond their rated capacity. In large plants, with economical boilers and engines, good fuel and other favorable conditions, which will reduce the maximum rate of coal consumption at any one time to less than 5 lbs. per H.P. per hour, the figures in the table may be multiplied by the ratio of 5 to the maximum expected coal consumption per H.P. per hour. Thus, with conditions which make the maximum coal consumption only 2.5 lbs. per hour, the chimney 300 ft. high  $\times$  12 ft. diameter should be sufficient for  $6155 \times 2 = 12,310$  horse-power. The formula is based on the following data:

1. The draught power of the chimney varies as the square root of the height.

2. The retarding of the ascending gases by friction may be considered as equivalent to a diminution of the area of the chimney, or to a lining of the chimney by a layer of gas which has no velocity. The thickness of this lining is assumed to be 2 inches for all chimneys, or the diminution of area equal to the perimeter  $\times$  2 inches (neglecting the overlapping of the corners of the lining). Let  $D$  = diameter in feet,  $A$  = area, and  $E$  = effective area in square feet:

$$\text{For square chimneys, } E = D^2 - \frac{8D}{12} = A - \frac{2}{3}\sqrt{A}.$$

$$\text{For round chimneys, } E = \frac{\pi}{4} \left( D^2 - \frac{8D}{12} \right) = A - 0.591\sqrt{A}.$$

For simplifying calculations, the coefficient of  $\sqrt{A}$  may be taken as 0.6 for both square and round chimneys, and the formula becomes

$$E = A - 0.6 \sqrt{A}.$$

3. The power varies directly as this effective area  $E$ .

4. A chimney should be proportioned so as to be capable of giving sufficient draught to cause the boiler to develop much more than its rated power, in case of emergencies, or to cause the combustion of 5 lbs. of fuel per rated horse-power of boiler per hour.

5. The power of the chimney varying directly as the effective area,  $E$ , and as the square root of the height,  $H$ , the formula for horse-power of boiler for a given size of chimney will take the form  $H.P. = CE \sqrt{H}$ , in which  $C$  is a constant, the average value of which, obtained by plotting the results obtained from numerous examples in practice, the author finds to be 3.33.

The formula for horse-power then is

$$H.P. = 3.33 E \sqrt{H}, \text{ or } H.P. = 3.33 (A - 0.6 \sqrt{A}) \sqrt{H}.$$

If the horse-power of boiler is given, to find the size of chimney, the height being assumed,

$$E = 0.3 H.P. \div \sqrt{H}; = A - 0.6 \sqrt{A}.$$

For round chimneys, diameter of chimney = diam. of  $E + 4''$ .

For square chimneys, side of chimney =  $\sqrt{E} + 4''$ .

If effective area  $E$  is taken in square feet, the diameter in inches is  $d = 13.54 \sqrt{E} + 4''$ , and the side of a square chimney in inches is  $s = 12 \sqrt{E} + 4''$ .

If horse-power is given and area assumed, the height  $H = \left( \frac{0.3 H.P.}{E} \right)^2$ .

An approximate formula for chimneys above 1000 H.P. is  $H.P. = 2.5 D^2 \sqrt{H}$ . This gives the H.P. somewhat greater than the figures in the table.

In proportioning chimneys the height should first be assumed, with due consideration of the heights of surrounding buildings or hills near to the proposed chimney, the length of horizontal flues, the character of coal to be used, etc.; then the diameter required for the assumed height and horse-power is calculated by the formula or taken from the table.

**For Height of Chimneys** see pages 947 and 948. No formula for height can be given which will be satisfactory for different classes of coal, kinds and amounts of ash, styles of grate-bars, etc. A formula in "Ingenieurs Taschenbuch," translated into English measures, is  $h = 0.216 R^2 + 6 d$ .  $h$  = height in ft;  $R$  = lbs. coal burned per sq. ft. of grate per hour;  $d$  = diam. in ft. This formula gives an insufficient height for small sizes of anthracite, and a height greater than is necessary for free-burning bituminous coal low in ash.

**The Protection of Tall Chimney-shafts from Lightning.** — C. Molyneux and J. M. Wood (*Industries*, March 23, 1890) recommend for tall chimneys the use of a coronal or heavy band at the top of the chimney, with copper points 1 ft. in height at intervals of 2 ft. throughout the circumference. The points should be gilded to prevent oxidation. The most approved form of conductor is a copper tape about  $\frac{3}{4}$  in. by  $\frac{1}{8}$  in. thick, weighing 6 ozs. per ft. If iron is used it should weigh not less than  $2\frac{1}{4}$  lbs. per ft. There must be no insulation, and the copper tape should be fastened to the chimney with holdfasts of the same material, to prevent voltaic action. An allowance for expansion and contraction should be made, say 1 in. in 40 ft. Slight bends in the tape, not too abrupt, answer the purpose. For an earth terminal a plate of metal at least 3 ft. sq. and  $\frac{1}{16}$  in. thick should be buried as deep as possible in a damp spot. The plate should be of the same metal as the conductor, to which it should be soldered. The best earth terminal is water, and when a deep well or other large body of water is at hand, the conductor should be carried down into it. Right-angled bends in the conductor should be avoided. No bend in it should be over  $30^\circ$ .



Size of Chimneys for Steam-boilers.  
 Formula, H.P. = 3.33 (A - 0.6 √A) √H. (Assuming 1 H.P. = 5 lbs. of coal burned per hour.)

Diam. inches.	Area A. sq. ft.	Effective Area. $E = A - \frac{0.6 \sqrt{A}}{sq. ft.}$	Height of Chimney.										Equivalent Square Chimney. Side of Square $\sqrt{E + 4 ins.}$												
			Commercial Horse-power of Boiler.																						
			50 ft.	60 ft.	70 ft.	80 ft.	90 ft.	100 ft.	110 ft.	125 ft.	150 ft.	175 ft.		200 ft.	225 ft.	250 ft.	300 ft.								
18	1.77	0.97	23	25	27	29																		16	
21	2.41	1.47	35	38	41	44																			19
24	3.14	2.08	49	54	58	62	66																		22
27	3.98	2.78	65	72	78	83	88																		24
30	4.91	3.58	84	92	100	107	113																		27
33	5.94	4.48		115	125	133	141	149																	30
36	7.07	5.47		141	152	163	173	182																	32
39	8.30	6.57			183	196	208	219	229	245	268														35
42	9.62	7.76			216	231	245	258	271	289	316	342													38
48	12.57	10.44				311	330	348	365	389	426	460	492												43
54	15.90	13.51					427	449	472	503	551	595	636	675											48
60	19.64	16.98						536	565	593	632	692	748	800	848										54
66	23.76	20.83							694	728	776	849	918	981	1040	1097	1201								59
72	28.27	25.08							835	876	934	1023	1105	1181	1253	1320	1447								64
78	33.18	29.73								1038	1107	1212	1310	1400	1485	1565	1715								70
84	38.48	34.76								1214	1294	1418	1531	1637	1736	1830	2005								75
90	44.18	40.19									1496	1639	1770	1893	2008	2116	2318								80
96	50.27	46.01									1712	1876	2027	2167	2298	2423	2654								86
102	56.75	52.23									1944	2130	2300	2459	2609	2750	3012								91
108	63.62	58.83									2090	2399	2592	2771	2939	3098	3393								96
114	70.88	65.83									2685	2900	3100	3288	3466	3797									101
120	78.54	73.22									2986	3226	3448	3657	3855	4223									107
132	95.03	89.18									3637	3929	4200	4455	4696	5144									117
144	113.10	106.72									4352	4701	5026	5331	5618	6155									128

For pounds of coal burned per hour for any given size of chimney, multiply the figures in the table by 5.

**Velocity of Gas in Chimneys.**—The velocity of the heated gas, based on the chimney proportions given in the table, may be found from the following data:

A = Lb. coal per hour = boiler horsepower × 5;

B = Lb. gas per lb. coal = say 20 lb.;

C = Cu. ft. of gas per lb. of gas =  $12.4 \times (\text{temp. of gas} + 460) \div 492$ ;  
 = 25 cu. ft. for 532° F. = 500 cu. ft. per lb. coal;

$$V = \text{Velocity of gas, feet per second} = \frac{A \times B \times C}{\text{Chimney area (sq. ft.)} \times 3600}$$

Based on a gas temperature of 532° F., 5 lb. coal per hour per rated H.P., and 20 lb. gas per lb. of coal we have

Cu. ft. gas per second per lb. of coal per hour = 0.1389;

Cu. ft. gas per second per boiler horse-power = 0.6944;

and the velocities in feet per second, based on the effective areas given in the table, corresponding to different heights of chimney are:

Height, ft. . .	50	60	70	80	90	100	110	125	150	175	200	225	250	300
Velocity, ft. per sec. . .	16.3	17.8	19.4	20.7	22.0	23.2	24.3	25.9	28.3	30.6	32.7	34.7	36.6	40.1

**Chimney Table for Oil Fuel.** (C. R. Weymouth, *Journal A. S. M.E.*, October, 1912.)—Conditions: Sea level; atmospheric temperature, 80° F.; draught at chimney side of damper, 0.30 in.; excess air, less than 50%, assumed 50% for calculations of efficiency and chimney dimensions; temperature of gases leaving chimney, 500° F.; boiler efficiency, 73%; actual boiler horse-power, 150 per cent of rated; lb. gas per actual boiler H.P., 54.6; height of chimney above point of draught measurement, 12 ft. less than tabulated height. When building conditions permit select chimneys of least height in table for minimum cost of chimney. Chimney capacities stated are maximum for continuous load equally divided on all boilers. For large plants or swinging load, reduce capacity 10 to 20%. Breeching 20% in excess of stack area; length not exceeding 10 chimney diameters.

**Size of Chimneys for Oil Fuel**

Diam., In.	Area, Sq. ft.	Height in Feet above Boiler Room Floor.									
		80	90	100	110	120	130	140	150	160	
Actual Horse-power = 150 Per cent of Rated.											
18	1.77	63	75	84	91	96	101	104	108	110	
24	3.14	123	148	166	180	191	201	208	215	221	
30	4.91	206	249	280	304	324	340	354	366	377	
36	7.07	312	379	427	466	497	523	545	564	581	
42	9.62	443	539	609	665	711	749	782	810	830	
48	12.57	599	729	827	904	967	1,020	1,070	1,110	1,145	
54	15.90	779	951	1,080	1,180	1,270	1,340	1,400	1,460	1,500	
60	19.64	985	1,200	1,370	1,500	1,610	1,710	1,790	1,860	1,920	
66	23.76	1,220	1,490	1,700	1,860	2,000	2,120	2,220	2,310	2,390	
72	28.27	1,470	1,810	2,060	2,260	2,430	2,580	2,710	2,820	2,910	
78	33.18	1,750	2,150	2,460	2,710	2,910	3,000	3,250	3,380	3,500	
84	38.49	2,060	2,530	2,900	3,190	3,440	3,650	3,840	4,000	4,150	
96	50.27	2,750	3,390	3,880	4,290	4,630	4,920	5,180	5,400	5,610	
108	63.62	3,550	4,380	5,020	5,550	6,000	6,390	6,730	7,030	7,300	
120	78.54	4,440	5,490	6,310	6,990	7,560	8,060	8,490	8,890	9,240	
132	95.03	5,450	6,740	7,760	8,600	9,310	9,930	10,500	11,000	11,400	
144	113.1	6,550	8,120	9,350	10,400	11,200	12,000	12,700	13,300	13,800	
156	132.7	7,760	9,630	11,100	12,300	13,400	14,300	15,100	15,800	16,500	
168	153.9	9,060	11,300	13,000	14,400	15,700	16,800	17,700	18,600	19,400	
180	176.7	10,500	13,000	15,100	16,700	18,200	19,500	20,600	21,600	22,600	

In using the above table it must be noted that the conditions upon which it is based are all fairly good. With unskilful handling of oil

fuel the excess air is apt to be much more than 50% and the efficiency much less than 73%. In that case the actual horse-power developed by a given size of chimney may be much less than the figure given in the table

#### draught of Chimneys 100 Ft. High—Oil Fuel.

Temp. of gases entering chimney . . . . .		300	400	500	600	700
		Net chimney draught, inches of water				
Temp. of outside air. {	60° F.	0.367	0.460	0.534	0.593	0.642
	80	0.325	0.417	0.490	0.550	0.599
	100	0.284	0.377	0.451	0.510	0.559

The net draught is the theoretical draught due to the difference in weight of atmospheric air and chimney gases at the stated temperatures, multiplied by a coefficient, 0.95, for temperature drop in stack, and by  $\frac{5}{6}$  as a correction for friction. For high altitudes the draught varies directly as the normal barometer. For other heights than 100 feet (measured above the level of entrance of the gases) the draught varies as the square root of the height.

**Chimneys with Forced Draught.**—When natural, or chimney, draught only is used, the function of the chimney is 1, to produce such a difference of pressure, or intensity of draught, between the bottom of the chimney and the ash-pit as will cause the flow of the required quantity of air through the grate-bars and the fuel bed, and the flow of the gases of combustion through the gas passages, the damper and the breeching; and 2, to convey the gases above the tops of surrounding buildings and to such a height that they will not become a nuisance. With forced draught the blower produces the difference of pressure, and the only use of the chimney is that of conveying the gases to a place where they will cause no inconvenience; and in that case the height of the chimney may be much less than that of a chimney for natural draught.

With oil or natural gas for fuel, the resistance of the grates and of the fuel bed is eliminated, and the height of the chimney may be much less than that of one desired for coal firing. When oil or gas is substituted for coal, and the chimney is a high one, it may be necessary to restrict its draught power by a damper or other means, in order to prevent its creating too great a negative pressure in the furnace and thereby too great an admission of air, which will cause a decrease in efficiency.

**The Largest Chimney in the World, in 1908,** is that of the Montana smelter, at Great Falls, Mont. Height 506 ft. Internal diam. at top 50 ft. Built of Custodis radial brick. Designed to remove 4,000,000 cu. ft. of gases per minute at an average temperature of 600° F. Erected on top of a hill 500 ft. above the city, and 246 ft. above the floor of the furnaces, which are about 2000 ft. distant. Designed for a wind pressure of 33 $\frac{1}{3}$  lbs. per sq. ft. of projected area; bearing pressure limited to 21 tons per sq. ft. at any section. Foundation: 111 ft. max. diam., 221 $\frac{1}{2}$  ft. deep; bearing pressure on bottom (shale rock) 4.83 tons per sq. ft.; octagonal outside, 103 ft. across at bottom, 81 ft. at top, with inner circular opening 47 ft. diam. at bottom, 64 ft. at top; made of 1 cement, 3 sand, 5 crushed slag. Four flue openings in the base, each 15 ft. wide, 36 ft. high. The stack proper consists of an octagonal base, 46 ft. in height, which has a taper of 8%, and above this a circular barrel, the first 180 ft. above the base having a taper of 7%, the next 100 ft. of 4%, and the remaining 180 ft. to the cap 2%.

The chimney wall varies from 66 in. at the base to 181 $\frac{1}{8}$  in. at the top by uniform decrements of 2 in. per section, excepting at the section immediately above the top of the base, where the thickness decreases from 60 in. to 54 in. The outside diameters of the stack are 781 $\frac{1}{2}$  ft. at the base, 53 ft. 9 in. at the base of the cap; the inside diameters range from 661 $\frac{1}{2}$  ft. at the foundation line to 50 ft. at the top. The chimney is lined with 4-inch acid-proof brick, laid in sections carried on corbels from the main shell. A description of the methods of design and of erection of the Great Falls chimney is given in *Eng. Rec.*, Nov. 28, 1908.



## Some Tall Brick Chimneys (1895).

	Height.	Internal Diam.	Outside Diameter.		Capacity by the Author's Formula.	
			Base.	Top.	H. P.	Pounds Coal per Hour.
1. Hallsbrückner Hütte, Saxony.....	460	15.7'	33'	16'	13,221	66,105
2. Townsend's, Glasgow.....	454	.....	32	.....	.....	.....
3. Tennant's, Glasgow.....	435	13' 6"	40	.....	9,795	48,975
4. Dobson & Barlow, Bolton, Eng.....	367 1/2	13' 2"	33' 10"	.....	8,245	41,225
5. Fall River Iron Co., Boston.....	350	11	30	21	5,558	27,790
6. Clark Thread Co., Newark, N. J.....	335	11	28' 6"	14	5,435	27,175
7. Merrimac Mills, Lowell, Mass.....	282' 9"	12	.....	.....	5,980	29,900
8. Washington Mills, Lawrence, Mass.....	250	10	.....	.....	3,839	19,195
9. Amoskeag Mills, Manchester, N. H.....	250	10	.....	.....	3,839	19,195
10. Narragansett E. L. Co., Providence, R. I.....	238	14	.....	.....	7,515	37,575
11. Lower Pacific Mills, Lawrence, Mass.....	214	8	.....	.....	2,248	11,240
12. Passaic Print Works, Passaic, N. J.....	200	9	.....	.....	2,771	13,855
13. Edison Station Brooklyn, Two each.....	150	50" x 120"	.....	each	1,541	7,705

NOTES ON THE ABOVE CHIMNEYS. — 1. This chimney is situated near Freiberg, at an elevation of 219 ft. above that of the foundry works, so that its total height above the sea will be 711 3/4 ft. The furnace-gases are conveyed across river to the chimney on a bridge, through a pipe 3227 ft. long. It is built of brick, and cost about \$40,000. — *Mfr. & Bldr.*

2. Owing to the fact that it was struck by lightning, and somewhat damaged, as a precautionary measure a copper extension subsequently was added to it, making its entire height 488 feet.

1, 2, 3, and 4 were built of these great heights to remove deleterious gases from the neighborhood, as well as for draught for boilers.

5. The structure rests on a solid granite foundation, 55 x 30 feet, and 16 feet deep. In its construction there were used 1,700,000 bricks, 2000 tons of stone, 2000 barrels of mortar, 1000 loads of sand, 1000 barrels of Portland cement, and the estimated cost is \$40,000. It is arranged for two flues, 9 feet 6 inches by 6 feet, connecting with 40 boilers, which are to be run in connection with four triple-expansion engines of 1350 horse-power each.

6. It has a uniform batter of 2.85 ins. to every 10 ft. Designed for 21 boilers of 200 H.P. each. It is surmounted by a cast-iron coping which weighs six tons, and is composed of 32 sections bolted together by inside flanges so as to present a smooth exterior. The foundation is 40 ft. square and 5 ft. deep. Two qualities of brick were used; the outer portions were of the first quality North River, and the backing up was of good quality New Jersey brick. Every twenty feet in vertical measurement an iron ring, 4 ins. wide and 3/4 to 1/2 in. thick, placed edge-wise, was built into the walls about 8 ins. from the outer circle. As the chimney starts from the base it is double. The outer wall is 5 ft. 2 ins. in thickness, and inside of this is a second wall 20 ins. thick and spaced

off about 20 ins. from main wall. From the interior surface of the main wall eight buttresses are carried, nearly touching this inner or main flue wall in order to keep it in line should it tend to sag. The interior wall, starting with the thickness described, is gradually reduced until a height of about 90 ft. is reached, when it is diminished to 8 inches. At 165 ft. it ceases, and the rest of the chimney is without lining. The total weight of the chimney and foundation is 5000 tons. It was completed in September, 1888.

7. Connected to 12 boilers, with 1200 sq. ft. of grate. Draught  $1\frac{9}{16}$  ins.
8. Connected to 8 boilers, 6 ft. 8 in. diam.  $\times$  18 ft. Grate 448 sq. ft.
9. Connected to 64 Manning vertical boilers, total grate surface 1810 sq. ft. Designed to burn 18,000 lbs. anthracite per hour.
10. Designed for 12,000 H.P. of engines; (compound condensing).
11. Grate-surface 434 square feet; H.P. of boilers about 2500.
13. Eight boilers (water-tube) each 450 H.P.; 12 engines, each 300 H.P. For the first 60 feet the exterior wall is 28 ins. thick, then 24 ins. for 20 ft., 20 ins. for 30 ft., 16 ins. for 20 ft., and 12 ins. for 20 ft. The interior wall is 9 ins. thick of fire-brick for 50 ft., and then 8 ins. thick of red brick for the next 30 ft. Illustrated in *Iron Age*, Jan. 2, 1890.

A number of the above chimneys are illustrated in *Power*, Dec., 1890.

**More Recent Brick Chimneys (1909).**—Heller & Merz Co., Newark, N. J. 350 ft. high, inside diam., 8 ft. Outside diam., top 9 ft.  $10\frac{1}{4}$  in., bottom 27 ft.  $6\frac{1}{2}$  in. Outside taper 5.2 in 100. Outer shell  $7\frac{1}{8}$  in. at the top, 38 in. at the bottom. Custodis radial brick laid in mortar of 1 cement, 2 lime, 5 sand. The changes in thickness are made by 2-in. offsets on the inside every 20 ft. Iron band  $3\frac{1}{2} \times \frac{5}{16}$  in., three courses below the top. Lined with 4 in. of special brick to resist acids. The lining is sectional, being carried on corbels projecting from the shell every 20 ft. An air space of 2 ins. is left between the lining and the shell. The lining bricks are laid in a mortar made of silicate of soda and white asbestos wool, tempered to the consistency of fire-clay mortar. This mortar is acid-proof, and its binding power, which is considerable in comparison to that of fire-clay mortar, is unaffected by temperatures up to 2000° F. (*Eng. News*, Feb. 15, 1906.) Supported on 324 piles driven 60 ft. to solid rock, and covering an area 45 ft. square. Total cost \$32,000. The standard Custodis radial brick is  $4\frac{1}{2}$  in. thick and  $6\frac{1}{2}$  in. wide; radial lengths are 4,  $5\frac{1}{2}$ ,  $7\frac{1}{8}$ ,  $8\frac{5}{8}$  and  $10\frac{5}{8}$  ins. The smallest size has six vertical perforations, 1 in. square, and the largest fifteen.

Eastman Kodak Co., Rochester, N. Y. Height 366 ft.; internal diam. at top 9 ft. 10 ins., at bottom 20 ft. 10 ins.; outside diam., top 11 ft., bottom 27 ft. 10 ins. Radial brick, with 4-in. acid-resisting brick lining.

Some notable tall chimneys built by the Alphonse Custodis Chimney Construction Co. are: Dolgeville, N. Y.,  $6 \times 175$  ft.; Camden, N. J.,  $7 \times 210$  ft.; Newark, N. J.,  $8 \times 350$  ft.; Rochester, N. Y.,  $9 \times 366$  ft.; Constable Hook, N. J.,  $10 \times 365$  ft.; Providence, R. I.,  $16 \times 308$  ft.; Garfield, Utah.  $30 \times 300$  ft.; Great Falls Mont.,  $50 \times 506$  ft.

**Interior Stack of the Equitable Building, New York City** (*Eng. News*, Nov. 12, 1914).—The stack is 11 ft. outside diam., 596 ft. high, made of steel plates  $\frac{5}{16}$  in. thick. It is supported on the steelwork of the building at every other story. It has a 2-in. lining of J. & M. Vitribestos, alternate layers of plain and corrugated asbestos board coated with a supposedly vitrified compound. The rated H.P. of this chimney, taking 10 ft. 7 in. as the inside diameter, is 6710, equivalent to the burning of 33,550 lb. of coal per hour.

**Stability of Chimneys.**—Chimneys must be designed to resist the maximum force of the wind in the locality in which they are built. A general rule for diameter of base of brick chimneys, approved by many years of practice in England and the United States, is to make the diameter of the base one-tenth of the height. If the chimney is square or rectangular, make the diameter of the inscribed circle of the base one-tenth of the height. The "batter" or taper of a chimney should be from  $\frac{1}{16}$  to  $\frac{1}{4}$  inch to the foot on each side. The brickwork should be one brick (8 or 9 inches) thick for the first 25 feet from the top, increasing  $\frac{1}{2}$  brick (4 or  $4\frac{1}{2}$  inches) for each 25 feet from the top downwards. If the inside diameter exceeds 5 feet, the top length should be  $\frac{1}{2}$  bricks; and if under 3 feet, it may be  $\frac{1}{2}$  brick for ten feet.

(From *The Locomotive*, 1884 and 1886.) For chimneys of four feet in

diameter and one hundred feet high, and upwards, the best form is circular with a straight batter on the outside.

Chimneys of any considerable height are not built up of uniform thickness from top to bottom, nor with a uniformly varying thickness of wall, but the wall, heaviest of course at the base, is reduced by a series of steps.

Where practicable the load on a chimney foundation should not exceed two tons per square foot in compact sand, gravel, or loam. Where a solid rock-bottom is available for foundation, the load may be greatly increased. If the rock is sloping, all unsound portions should be removed, and the face dressed to a series of horizontal steps, so that there shall be no tendency to slide after the structure is finished.

All boiler-chimneys of any considerable size should consist of an outer stack of sufficient strength to give stability to the structure, and an inner stack or core independent of the outer one. This core is by many engineers extended up to a height of but 50 or 60 feet from the base of the chimney, but the better practice is to run it up the whole height of the chimney; it may be stopped off, say, a couple of feet below the top, and the outer shell contracted to the area of the core, but the better way is to run it up to about 8 or 12 inches of the top and *not* contract the outer shell. But under no circumstances should the core at its upper end be built into or connected with the outer stack. This has been done in several instances by bricklayers, and the result has been the expansion of the inner core which lifted the top of the outer stack squarely up and cracked the brickwork.

For a height of 100 feet we would make the outer shell in three steps, the first 20 feet high, 16 inches thick, the second 30 feet high, 12 inches thick, the third 50 feet high and 8 inches thick. These are the minimum thicknesses admissible for chimneys of this height, and the batter should be not less than 1 in 36 to give stability. The core should also be built in three steps, each of which may be about one-third the height of the chimney, the lowest 12 inches, the middle 8 inches, and the upper step 4 inches thick. This will insure a good sound core. The top of a chimney may be protected by a cast-iron cap; or perhaps a cheaper and equally good plan is to lay the ornamental part in some good cement, and plaster the top with the same material.

C. L. Hubbard (*Am. Electrician*, Mar., 1904) says: The following approximate method may be used for determining the thickness of walls. If the inside diameter at the top is less than 3 ft. the walls may be 4 ins. thick for the first 10 ft., and increased 4 ins. for each 25 ft. downward. If the inside diameter is more than 3 ft. and less than 5 ft., begin with a wall 8 ins. thick, increasing 4 ins. for each 25 ft. downward. If the diameter is over 5 ft., begin with a 12-in. wall, increasing below the first 10 ft. as before. The lining or core may be 4 ins. thick for the first 20 ft. from the top, 8 ins. for the next 30 ft., 12 ins. for the next 40 ft., 16 ins. for the next 50 ft., and 20 ins. for the next 50 ft. Using this method for an outer wall 200 ft. high and assuming a cubic foot of brickwork to weigh 130 lbs., it gives a maximum pressure of 8.2 tons per sq. ft. of section at the base; while a lining 190 ft. high would have a maximum pressure of 8.6 tons per sq. ft. The safe load for brickwork may be taken at from **8 to 10 tons per sq. ft.**, although the strength of best pressed brick will run much higher.

James B. Francis, in a report to the Lawrence Mfg. Co. in 1873 (*Eng. News*, Aug. 28, 1880), concerning the probable effects of wind on that company's chimney as then constructed, says:

The stability of the chimney to resist the force of the wind depends mainly on the weight of its outer shell, and the width of its base. The cohesion of the mortar may add considerably to its strength; but it is too uncertain to be relied upon. The inner shell will add a little to the stability, but it may be cracked by the heat, and its beneficial effect, if any, is too uncertain to be taken into account.

The effect of the joint action of the vertical pressure due to the weight of the chimney, and the horizontal pressure due to the force of the wind is to shift the center of pressure at the base of the chimney, from the axis toward one side, the extent of the shifting depending on the relative magnitude of the two forces. If the center of pressure is brought too near the side of the chimney, it will crush the brickwork on that side, and the



chimney will fall. A line drawn through the center of pressure, perpendicular to the direction of the wind, must leave an area of brickwork between it and the side of the chimney, sufficient to support half the weight of the chimney; the other half of the weight being supported by the brickwork on the windward side of the line.

Different experimenters on the strength of brickwork give very different results. Kirkaldy found the weights which caused several kinds of bricks, laid in hydraulic lime mortar and in Roman and Portland cements, to fail slightly, to vary from 19 to 60 tons (of 2000 lbs.) per sq. ft. If we take in this case 25 tons per sq. ft. as the weight that would cause it to begin to fail, we shall not err greatly.

Rankine, in a paper printed in the transactions of the Institution of Engineers, in Scotland, for 1867-68, says: "It had previously been ascertained by observation of the success and failure of actual chimneys, and especially of those which respectively stood and fell during the violent storms of 1856, that, in order that a round chimney may be sufficiently stable, its weight should be such that a pressure of wind, of about 55 lbs. per sq. ft. of a plane surface, directly facing the wind, or  $27\frac{1}{2}$  lbs. per sq. ft. of the plane projection of a cylindrical surface, . . . shall not cause the resultant pressure at any bed-joint to deviate from the axis of the chimney by more than one-quarter of the outside diameter at that joint."

**Steel Chimneys** are largely used, especially for tall chimneys of iron-works, from 150 to 300 feet in height. The advantages claimed are: greater strength and safety; smaller space required; smaller cost, by 30 to 50 per cent, as compared with brick chimneys; avoidance of infiltration of air and consequent checking of the draught, common in brick chimneys. They are usually made cylindrical in shape, with a wide curved flare for 10 to 25 feet at the bottom. A heavy cast-iron base-plate is provided, to which the chimney is riveted, and the plate is secured to a massive foundation by holding-down bolts. No guys are used.

**Design of Self-supporting Steel Chimneys.** — John D. Adams (*Eng. News*, July 20, 1905) gives a very full discussion of the design of steel chimneys, from which the following is adapted. The bell-shaped bottom of the chimney is assumed to occupy one-seventh of the total height, and the point of maximum strain is taken to be at the top of this bell portion. Let  $D$  = diam. in inches,  $H$  = height in feet,  $T$  = thickness in inches,  $S$  = safe tensile stress, lbs. per sq. in. The general formula for moment of resistance of a hollow cylinder is  $M = \frac{1}{32} \pi (D^4 - D_1^4) S/D$ . When the thickness is a small fraction of the diameter this becomes approximately  $M = 0.7854 D^2 T S$ .

With steel plate of 60,000 lbs. tensile strength, riveting of 0.6 efficiency, and a factor of safety of 4, we have  $S = 9000$  pounds per sq. in., and the safe moment of resistance =  $7070 D^2 T$ .

The effect of the wind upon a cylinder is equal to the wind pressure multiplied by one-half the diametral plane, and taking the maximum wind pressure at 50 lbs. per sq. ft., we get

$$\text{Total wind pressure} = 50 \times \frac{1}{12} D \times \frac{1}{2} \times \frac{6}{7} H = 25 DH/14.$$

The distance of the center of pressure above the top of the bell portion =  $\frac{3}{7} H$ , multiplied by the total wind pressure, gives us the bending moment due to the wind,

$$\text{inch-pounds, } 25 DH/14 \times \frac{3}{7} H \times 12 = 9.184 DH^2.$$

Equating the bending and the resisting moment we have  $T = 0.0013 H^2/D$ .

With this formula the maximum thickness of plates was calculated for different sizes of chimneys, as given in the table on p. 957.

In the above formula, no attention has been paid to the weight of the steel in the stack above the bell portion, which weight has a tendency to decrease the tension on the windward side and increase the compression on the leeward side of the stack. A column of steel 150 ft. high would exert a pressure of approximately 500 lb. per sq. in., which, with steel of 60,000 lb. tensile strength, is less than 1% of the ultimate strength, and may safely be neglected.

From the table it appears that a chimney  $12 \times 120$  ft. requires, as far as fracture by bending of a tubular section is concerned, a thickness of but little over  $\frac{1}{8}$  in. In designing a stack of such extreme proportions

as 12 × 120 ft., there are other factors besides bending to take into consideration that ordinarily could be neglected. For instance, such a stack should be provided with stiffening angles, or else made heavier, to guard against lateral flattening. Ordinarily, however, the strength of the chimney determined as a tubular section will be the prime factor in determining the maximum thickness of plates.

THICKNESS OF BASE-RING PLATES OF SELF-SUPPORTING STEEL STACKS.  
For normal wind pressure of 50 lbs. per sq. ft. on half the diametral plane  
Diameter of Stack in feet.

Hgt. ft.	3.5	4	5	6	7	8	8.5	9	9.5	10	11	12
70	0.152	.133	.106	.....	.....	.....	.....	.....	.....	.....	.....	.....
80	0.198	.182	.139	.116	.099	.....	.....	.....	.....	.....	.....	.....
90	0.224	.219	.175	.146	.125	.111	.....	.....	.....	.....	.....	.....
100	0.310	.271	.217	.181	.155	.135	.127	.120	.....	.....	.....	.....
110	0.375	.328	.262	.218	.187	.164	.154	.146	.138	.131	.119	.....
120	0.446	.390	.312	.260	.223	.195	.183	.173	.164	.156	.142	.130
130	0.523	.458	.366	.305	.262	.228	.215	.203	.193	.183	.166	.153
140	0.607	.531	.425	.354	.303	.265	.250	.236	.223	.212	.193	.180
150	0.696	.609	.487	.406	.348	.305	.286	.271	.257	.244	.222	.203
160	.....	.693	.555	.462	.396	.346	.326	.308	.292	.277	.252	.231
170	.....	.....	.626	.522	.447	.391	.368	.348	.330	.313	.285	.261
180	.....	.....	.702	.585	.501	.439	.413	.390	.370	.351	.319	.293
190	.....	.....	.....	.652	.559	.489	.460	.434	.411	.391	.356	.326
200	.....	.....	.....	.....	.620	.542	.510	.481	.456	.433	.394	.361
210	.....	.....	.....	.....	.682	.596	.562	.531	.503	.478	.434	.398
220	.....	.....	.....	.....	.....	.655	.617	.582	.552	.524	.476	.437
230	.....	.....	.....	.....	.....	.....	.717	.674	.637	.603	.521	.477
240	.....	.....	.....	.....	.....	.....	.....	.734	.693	.657	.624	.570
250	.....	.....	.....	.....	.....	.....	.....	.....	.752	.713	.677	.615

*Foundation.* — Neglecting the increase of wind area due to the flare at the base of the chimney, which has but a very small turning effect, if all dimensions be taken in feet, we have

Total wind pressure =  $\frac{1}{2} D \times H \times 50 = 25 DH$ ; lever-arm =  $\frac{1}{2} H$ ;  
hence, turning moment =  $12.5 DH^2$ .

Let  $d$  = diameter and  $h$  = height of foundation. For average conditions  $h = 0.4 d$ , then volume of foundation =  $0.7854 d^2 h$ , and for concrete at 150 lbs. per cu. ft., weight of foundation =  $W = 0.7854 d^2 h \times 150 = 47.124 d^3$ .

The stability of the foundation or the tendency to resist overturning is equal to the weight of the foundation multiplied by its radius or  $\frac{1}{2} Wd = 23.562 d^4$ . Applying a factor of safety of  $2\frac{1}{2}$ , which is indicated by current practice, gives safe stability =  $9.425 d^4$ . Equating this to the overturning moment we obtain  $d = 1.07 \sqrt[4]{DH^2}$ , in which all dimensions are in feet.

*Anchor-bolts.* — The holding power of the bolts depends on three factors: the number of bolts, the diameter of the bolt circle, and the diameter of the bolts. The number of bolts is largely conventional and may be selected so as not to necessitate bolts of too large a diameter. The diameter of the bolt circle is also more or less arbitrary. The bolts will be stretched and therefore strained, in proportion to their distance from the axis of turning, assuming, as we must, that the cast-iron ring at the base of the chimney is rigid. The leverage at which any bolt acts is also directly proportional to its distance from the axis of turning. Therefore, since the effectiveness of any one bolt, as regards overturning, depends upon the strain in that bolt, multiplied by its leverage, it is evident that the effectiveness of any bolt varies as the square of its distance from the axis of turning. If we lay out, say, 12 or 24 bolts equidistant on a circle and add all the squares of these distances, we will find that we may consider the total as though the bolts were all placed at a distance of  $\frac{3}{8}$  the diameter of the bolt circle from the axis of turning, which is the tangent to the bolt circle.

Let  $b$  = diameter of bolt in inches,  $n$  = number of bolts, diameter

of bolt circle =  $\frac{2}{3}d$ . Take safe working stress at 8000 pounds per sq. inch. Then resistance to overturning =  $0.7854 b^2 \times 8000 \times \frac{2}{3}d \times \frac{3}{8} \times N = 6283 b^2 N d / 4$ . Equating this to the turning moment,  $12.5 DH^2$ , gives  $v = 0.0257 H \sqrt{D/d}$  for 12 bolts,  $0.0222 H \sqrt{D/d}$  for 18 bolts, and  $0.0182 H \sqrt{D/d}$  for 24 bolts.

**Reinforced Concrete Chimneys** began extensively to come into use in the United States in 1901. Some hundreds of them are now (1909) in use. The following description of the method of construction of these chimneys is condensed from a circular of the Weber Chimney Co., Chicago.

The foundation is comparatively light and made of concrete, consisting of 1 cement, 3 sand, and 5 gravel or macadam. The steel reinforcement consists of two networks usually made of T steel of small size. The bars for the lower network are placed diagonally and the bars for the second network (about 4 to 6 ins. above the first one) run parallel to the sides. The vertical bars, forming the reinforcement of the chimney itself, also go down into the foundation and a number of these bars are bent in order to secure an anchorage for the chimney.

The chimney shaft consists of two parts, the lower double shell and the single shell above, which are united at the offset. The inside shell is usually 4 ins. thick, while the thickness of the outer shell depends on the height and varies from 6 to 12 ins. The single shell is from 4 to 10 ins. thick. The height of the double shell depends upon the purpose of the chimney, nature and heat of the gases, etc.

Between the two shells in the lower part there is a circular air space 4 ins. in width. An expansion joint is provided where the two shells unite.

The concrete above the ground level consists of one part Portland cement and three parts of sand. No gravel or macadam is used.

The bending forces caused by wind pressure are taken up by the vertical steel reinforcement. The resistance of the concrete itself against tension is not considered in calculation.

The vertical T bars are from  $1 \times 1 \times \frac{1}{8}$  to  $1\frac{1}{2} \times 1\frac{1}{2} \times \frac{1}{2}$  in., the weight and number depending upon the dimensions of the chimney. The bars are from 16 to 30 ft. long and overlap not less than 24 ins. They are placed at regular intervals of 18 ins. and encircled by steel rings bent to the desired circle.

The following is a list of some of the tallest concrete chimneys that have been built of their respective diameters: Butte, Mont.,  $350 \times 18$  ft.; Seattle, Wash.,  $278 \times 17$  ft.; Portland, Ore.,  $230 \times 12$  ft.; Lawrence, Mass.,  $250 \times 11$  ft.; Cincinnati, Ohio,  $200 \times 10$  ft.; Worcester, Mass.,  $220 \times 9$  ft.; Atlanta, Ga.,  $225 \times 8$  ft.; Chicago,  $175 \times 7$  ft.; Rockville, Conn.,  $175 \times 6$  ft.; Seymour, Ind.,  $150 \times 5$  ft.; Iola, Kans.,  $143 \times 4$  ft.; St. Louis, Mo.,  $130 \times 3$  ft. 4 in.; Dayton, Ohio,  $94 \times 3$  ft.

### Sizes of Foundations for Steel Chimneys.

(Selected from circular of Phila. Engineering Works.)

#### HALF-LINED CHIMNEYS.

Diameter, clear, feet.....	3	4	5	6	7	9	11
Height, feet.....	100	100	150	150	150	150	150
Least diam. foundation..	15'9"	16'4"	20'4"	21'10"	22'7"	23'8"	24'8"
Least depth foundation..	6'	6'	9'	8'	9'	10'	10'
Height, feet.....		125	200	200	250	275	300
Least diam. foundation..		18'5"	23'8"	25'	29'8"	33'6"	36'
Least depth foundation .		7'	10'	10'	12'	12'	14'

### Weight of Sheet-Iron Smoke-stacks per Foot.

(Porter Mfg. Co.)

Diam. inches.	Thick-ness. W. G.	Weight per ft.	Diam. inches.	Thick-ness. W. G.	Weight per ft.	Diam. inches.	Thick-ness. W. G.	Weight per ft.
10	No. 16	7.20	26	No. 16	17.50	20	No. 14	18.33
12	"	8.66	28	"	18.75	22	"	20.00
14	"	9.58	30	"	20.00	24	"	21.66
16	"	11.68	10	No. 14	9.40	26	"	23.33
20	"	13.75	12	"	11.11	28	"	25.00
22	"	15.00	14	"	13.69	30	"	26.66
24	"	16.25	16	"	15.00			



THE STEAM-ENGINE.

**Expansion of Steam. Isothermal and Adiabatic.** — According to Mariotte's law, the volume of a perfect gas, the temperature being kept constant, varies inversely as its pressure, or  $p \propto 1/v$ ;  $pv = \text{a constant}$ . The curve constructed from this formula is called the *isothermal* curve, or curve of equal temperatures, and is a common or rectangular hyperbola. The expansion of steam in an engine is not isothermal, since the temperature decreases with increase of volume, but its expansion curve approximates the curve of  $pv = \text{a constant}$ . The relation of the pressure and volume of saturated steam, as deduced from Regnault's experiments, and as given in steam tables, is approximately, according to Rankine (S. E., p. 403), for pressures not exceeding 120 lbs.,  $p \propto 1/v^{1\frac{1}{8}}$ , or  $p \propto v^{-1\frac{1}{8}}$  or  $pv^{1\frac{1}{8}} = pv^{1.0625} = \text{a constant}$ . Zeuner has found that the exponent 1.0646 gives a closer approximation.

When steam expands in a closed cylinder, as in an engine, according to Rankine (S. E., p. 385), the approximate law of the expansion is  $p \propto 1/v^{1\frac{10}{9}}$ , or  $p \propto v^{-1\frac{10}{9}}$ , or  $pv^{1\frac{10}{9}} = \text{a constant}$ . The curve constructed from this formula is called the *adiabatic* curve, or curve of no transmission of heat.

Peabody (Therm., p. 112) says: "It is probable that this equation was obtained by comparing the expansion lines on a large number of indicator-diagrams. . . . There does not appear to be any good reason for using an exponential equation in this connection, . . . and the action of a lagged steam-engine cylinder is far from being adiabatic. . . . For general purposes the hyperbola is the best curve for comparison with the expansion curve of an indicator-card. . . ." Wolff and Denton, *Trans. A. S. M. E.*, ii, 175, say: "From a number of cards examined from a variety of steam-engines in current use, we find that the actual expansion line varies between the 10/9 adiabatic curve and the Mariotte curve."

Prof. Thurston (*Trans. A. S. M. E.*, ii, 203) says he doubts if the exponent ever becomes the same in any two engines, or even in the same engine at different times of the day and under varying conditions of the day.

**Expansion of Steam according to Mariotte's Law and to the Adiabatic Law.** (*Trans. A. S. M. E.*, ii, 156.) — Mariotte's law  $pv =$

$p_1v_1$ ; values calculated from formula  $\frac{P_m}{p_1} = \frac{1}{R} (1 + \text{hyp log } R)$ , in which  $R = v_2 \div v_1$ ,  $p_1 =$  absolute initial pressure,  $P_m =$  absolute mean pressure,  $v_1 =$  initial volume of steam in cylinder at pressure  $p_1$ ,  $v_2 =$  final volume of steam at final pressure. Adiabatic law:  $pv^{1\frac{10}{9}} = p_1v_1^{1\frac{10}{9}}$ ; values calculated from formula  $\frac{P_m}{p_1} = 10 R^{-1} - 9 R^{-1\frac{10}{9}}$ .

Ratio of Expansion <i>R.</i>	Ratio of Mean to Initial Pressure.		Ratio of Expansion <i>R.</i>	Ratio of Mean to Initial Pressure.		Ratio of Expansion <i>R.</i>	Ratio of Mean to Initial Pressure.	
	Mar.	Adiab.		Mar.	Adiab.		Mar.	Adiab.
1.00	1.000	1.000	3.7	0.624	0.600	6.	0.465	0.438
1.25	.978	.976	3.8	.614	.590	6.25	.453	.425
1.50	.937	.931	3.9	.605	.580	6.5	.442	.413
1.75	.891	.881	4.	.597	.571	6.75	.431	.403
2.	.847	.834	4.1	.588	.562	7.	.421	.393
2.2	.813	.798	4.2	.580	.554	7.25	.411	.383
2.4	.781	.765	4.3	.572	.546	7.5	.402	.374
2.5	.766	.748	4.4	.564	.538	7.75	.393	.365
2.6	.752	.733	4.5	.556	.530	8.	.385	.357
2.8	.725	.704	4.6	.549	.523	8.25	.377	.349
3.	.700	.678	4.7	.542	.516	8.5	.369	.342
3.1	.688	.666	4.8	.535	.509	8.75	.362	.335
3.2	.676	.654	4.9	.528	.502	9.	.355	.328
3.3	.665	.642	5.0	.522	.495	9.25	.349	.321
3.4	.654	.630	5.25	.506	.479	9.5	.342	.315
3.5	.644	.620	5.5	.492	.464	9.75	.336	.309
3.6	.634	.610	5.75	.478	.450	10.	.330	.303

**Mean Pressure of Expanded Steam.** — For calculations of engines it is generally assumed that steam expands according to Mariotte's law, the curve of the expansion line being a hyperbola. The mean pressure, measured above vacuum, is then obtained from the formula

$$P_m = p_1 \frac{1 + \text{hyp log } R}{R}, \text{ or } P_m = P_t (1 + \text{hyp log } R),$$

in which  $P_m$  is the absolute mean pressure,  $p_1$  the absolute initial pressure taken as uniform up to the point of cut-off,  $P_t$  the terminal pressure, and  $R$  the ratio of expansion. If  $l$  = length of stroke to the cut-off,  $L$  = total stroke.

$$P_m = \frac{p_1 l + p_1 \text{hyp log } \frac{L}{l}}{L}; \text{ and if } R = \frac{L}{l}, P_m = p_1 \frac{1 + \text{hyp log } R}{R}.$$

**Mean and Terminal Absolute Pressures. — Mariotte's Law.** — The values in the following table are based on Mariotte's law, except those in the last column, which give the mean pressure of superheated steam, which, according to Rankine, expands in a cylinder according to the law  $p \propto v^{-\frac{1}{2}}$ . These latter values are calculated from the formula  $\frac{P_m}{p_1} = \frac{17 - 16 R^{-\frac{1}{2}}}{R}$ .  $R^{-\frac{1}{2}}$  may be found by extracting the square root of  $\frac{1}{R}$  four times. From the mean absolute pressures given deduct the mean back pressure (absolute) to obtain the mean effective pressure.

Rate of Expansion.	Cut-off.	Ratio of Mean to Initial Pressure.	Ratio of Mean to Terminal Pressure.	Ratio of Terminal to Mean Pressure.	Ratio of Initial to Mean Pressure.	Ratio of Mean to Initial Dry Steam.
30	0.033	0.1467	4.40	0.227	6.82	0.136
28	0.036	0.1547	4.33	0.231	6.46	.....
26	0.038	0.1638	4.26	0.235	6.11	.....
24	0.042	0.1741	4.18	0.239	5.75	.....
22	0.045	0.1860	4.09	0.244	5.38	.....
20	0.050	0.1998	4.00	0.250	5.00	0.186
18	0.055	0.2161	3.89	0.256	4.63	.....
16	0.062	0.2358	3.77	0.265	4.24	.....
15	0.066	0.2472	3.71	0.269	4.05	.....
14	0.071	0.2599	3.64	0.275	3.85	.....
13.33	0.075	0.2690	3.59	0.279	3.72	0.254
13	0.077	0.2742	3.56	0.280	3.65	.....
12	0.083	0.2904	3.48	0.287	3.44	.....
11	0.091	0.3089	3.40	0.294	3.24	.....
10	0.100	0.3303	3.30	0.303	3.03	0.314
9	0.111	0.3552	3.20	0.312	2.81	.....
8	0.125	0.3849	3.08	0.321	2.60	0.370
7	0.143	0.4210	2.95	0.339	2.37	.....
6.66	0.150	0.4347	2.90	0.345	2.30	0.417
6.00	0.166	0.4653	2.79	0.360	2.15	.....
5.71	0.175	0.4807	2.74	0.364	2.08	.....
5.00	0.200	0.5218	2.61	0.383	1.92	0.506
4.44	0.225	0.5608	2.50	0.400	1.78	.....
4.00	0.250	0.5965	2.39	0.419	1.68	0.582
3.63	0.275	0.6308	2.29	0.437	1.58	.....
3.33	0.300	0.6615	2.20	0.454	1.51	0.648
3.00	0.333	0.6995	2.10	0.476	1.43	.....
2.86	0.350	0.7171	2.05	0.488	1.39	0.707
2.66	0.375	0.7440	1.98	0.505	1.34	.....
2.50	0.400	0.7664	1.91	0.523	1.31	0.756
2.22	0.450	0.8095	1.80	0.556	1.24	0.800
2.00	0.500	0.8465	1.69	0.591	1.18	0.840
1.82	0.550	0.8786	1.60	0.626	1.14	0.874
1.66	0.600	0.9066	1.51	0.662	1.10	0.900
1.60	0.625	0.9187	1.47	0.680	1.09	.....
1.54	0.650	0.9292	1.43	0.699	1.07	0.926
1.48	0.675	0.9405	1.39	0.718	1.06	.....

**Calculation of Mean Effective Pressure, Clearance and Compression Considered.** — In the above tables no account is taken of

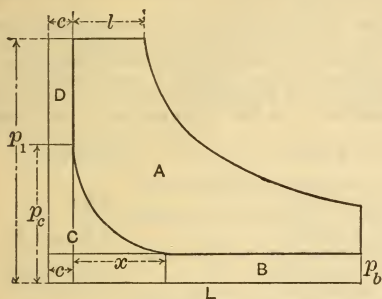

FIG. 161.

clearance, which in actual steam-engines modifies the ratio of expansion and the mean pressure; nor of compression and back-pressure, which diminish the mean effective pressure. In the following calculation these elements are considered.

$L$  = length of stroke,  $l$  = length before cut-off,  $x$  = length of compression part of stroke,  $c$  = clearance,  $p_1$  = initial pressure,  $p_b$  = back pressure,  $p_c$  = pressure of clearance steam at end of compression. All pressures are absolute, that is, measured from a perfect vacuum.

$$\text{Area of ABCD} = p_1(l+c) \left(1 + \text{hyp log } \frac{L+c}{l+c}\right);$$

$$B = p_b(L-x);$$

$$C = p_c c \left(1 + \text{hyp log } \frac{x+c}{c}\right) = p_b(x+c) \left(1 + \text{hyp log } \frac{x+c}{c}\right);$$

$$D = (p_1 - p_c)c = p_1c - p_b(x+c).$$

$$\text{Area of A} = \text{ABCD} - (B + C + D)$$

$$= p_1(l+c) \left(1 + \text{hyp log } \frac{L+c}{l+c}\right)$$

$$- \left[ p_b(L-x) + p_b(x+c) \left(1 + \text{hyp log } \frac{x+c}{c}\right) + p_1c - p_b(x+c) \right]$$

$$= p_1(l+c) \left(1 + \text{hyp log } \frac{L+c}{l+c}\right)$$

$$- p_b \left[ (L-x) + (x+c) \text{hyp log } \frac{x+c}{c} \right] - p_1c.$$

$$\text{Mean effective pressure} = \frac{\text{area of A}}{L}.$$

**EXAMPLE.** — Let  $L=1$ ,  $l=0.25$ ,  $x=0.25$ ,  $c=0.1$ ,  $p_1=60$  lbs.,  $p_b=2$  lbs.

$$\text{Area A} = 60(0.25 + 0.1) \left(1 + \text{hyp log } \frac{1.1}{0.35}\right)$$

$$- 2 \left[ (1-0.25) + 0.35 \text{hyp log } \frac{0.35}{0.1} \right] - 60 \times 0.1.$$

$$= 21(1 + 1.145) - 2[0.75 + 0.35 \times 1.253] - 6$$

$$= 45.045 - 2.377 - 6 = 36.668 = \text{mean effective pressure.}$$

The actual indicator-diagram generally shows a mean pressure considerably less than that due to the initial pressure and the rate of expansion. The causes of loss of pressure are: 1. Friction in the stop-valves and steam-pipes. 2. Friction or wire-drawing of the steam during admission and cut-off, due chiefly to defective valve-gear and contracted steam-passages. 3. Liquefaction during expansion. 4. Exhausting before the engine has completed its stroke. 5. Compression due to early closure of exhaust. 6. Friction in the exhaust-ports, passages, and pipes.



Re-evaporation during expansion of the steam condensed during admission, and valve-leakage after cut-off, tend to elevate the expansion line of the diagram and increase the mean pressure.

If the theoretical mean pressure be calculated from the initial pressure and the rate of expansion on the supposition that the expansion curve follows Mariotte's law,  $p v = a$  constant, and the necessary corrections are made for clearance and compression, the expected mean pressure in practice may be found by multiplying the calculated results by the factor (commonly called the "diagram factor") in the following table, according to Seaton.

Particulars of Engine.	Factor.
Expansive engine, special valve-gear, or with a separate cut-off valve, cylinder jacketed.....	0.94
Expansive engine having large ports, etc., and good ordinary valves, cylinders jacketed.....	0.9 to 0.92
Expansive engines with the ordinary valves and gear as in general practice, and unjacketed.....	0.8 to 0.85
Compound engines, with expansion valve to h.p. cylinder; cylinders jacketed, and with large ports, etc.....	0.9 to 0.92
Compound engines, with ordinary slide-valves, cylinders jacketed, and good ports, etc.....	0.8 to 0.85
Compound engines as in general practice in the merchant service, with early cut-off in both cylinders, without jackets and expansion-valves.....	0.7 to 0.8
Fast-running engines of the type and design usually fitted in war-ships.....	0.6 to 0.8

If no correction be made for clearance and compression, and the engine is in accordance with general modern practice, the theoretical mean pressure may be multiplied by 0.96, and the product by the proper factor in the table, to obtain the expected mean pressure.

**Given the Initial Pressure and the Average Pressure, to Find the Ratio of Expansion and the Period of Admission.**

- $P$  = initial absolute pressure in lbs. per sq. in.;
- $p$  = average total pressure during stroke in lbs. per sq. in.;
- $L$  = length of stroke in inches;
- $l$  = period of admission measured from beginning of stroke;
- $c$  = clearance in inches;

$$R = \text{actual ratio of expansion} = \frac{L + c}{l + c} \dots \dots \dots (1)$$

$$p = \frac{P (1 + \text{hyp log } R)}{R}$$

To find average pressure  $p$ , taking account of clearance,

$$p = \frac{P(l + c) + P(l + c) \text{ hyp log } R - Pc}{L}, \dots \dots \dots (2)$$

whence

$$pL + Pc = P(l + c) (1 + \text{hyp log } R);$$

$$\text{hyp log } R = \frac{pL + Pc}{Pl + Pc} - 1 = \frac{\frac{p}{P} L + c}{l + c} - 1. \dots \dots \dots (3)$$

Given  $p$  and  $P$ , to find  $R$  and  $l$  (by trial and error). — There being two unknown quantities  $R$  and  $l$ , assume one of them, viz., the period of admission  $l$ , substitute it in equation (3) and solve for  $R$ . Substitute this value of  $R$  in the formula (1), or  $l = \frac{L + c}{R} - c$ , obtained from formula (1), and find  $l$ . If the result is greater than the assumed value of  $l$ , then the assumed value of the period of admission is too long; if less, the assumed value is too short. Assume a new value of  $l$ , substitute it in formula (3) as before, and continue by this method of trial and error till the required values of  $R$  and  $l$  are obtained.

**EXAMPLE.** —  $P=70$ ,  $p=42.78$ ,  $L=60$  in.,  $c=3$  in., to find  $l$ . Assume  $l=21$  in.

$$\text{hyp log } R = \frac{\frac{p}{P} L + c}{l + c} - 1 = \frac{\frac{42.78}{70} \times 60 + 3}{21 + 3} - 1 = 1.653 - 1 = 0.653;$$

$\text{hyp log } R = 0.653$ , whence  $R = 1.92$ .

$$l = \frac{L + c}{R} - c = \frac{63}{1.92} - 3 = 29.8,$$

which is greater than the assumed value, 21 inches.

Now assume  $l = 15$  inches:

$$\text{hyp log } R = \frac{\frac{42.78}{70} \times 60 + 3}{15 + 3} - 1 = 1.204, \text{ whence } R = 3.5;$$

$$l = \frac{L + c}{R} - c = \frac{63}{3.5} - 3 = 18 - 3 = 15 \text{ inches, the value assumed.}$$

Therefore  $R = 3.5$ , and  $l = 15$  inches.

*Period of Admission Required for a Given Actual Ratio of Expansion:*

$$l = \frac{L + c}{R} - c, \text{ in inches . . . . . (4)}$$

$$\text{In percentage of stroke, } l = \frac{100 + \text{p. ct. clearance}}{R} - \text{p. ct. clearance . . . . . (5)}$$

$$\text{Terminal pressure} = \frac{P(L + c)}{L + c} = \frac{P}{R} \text{ . . . . . (6)}$$

*Pressure at any other Point of the Expansion.* — Let  $L_1 =$  length of stroke up to the given point.

$$\text{Pressure at the given point} = \frac{P(L + c)}{L_1 + c} \text{ . . . . . (7)}$$

**Mechanical Energy of Steam Expanded Adiabatically to Various Pressures.** — The figures in the following table are taken from a chart constructed by R. M. Neilson in *Power*, Mar. 16, 1909. The pressures are absolute, lbs per sq. in.

Initial Press.	Mechanical Energy, Thousands of Foot-Pounds per Lb. of Steam.											
	15	20	25	40	60	80	100	120	140	170	200	250
15	0	17	29.5	55.5	77.5	94.5	107	116.5	121	136.5	146	160
12	12	29	41	66.5	88	104	116	126	135	145	154.5	168.5
10	22	39	50.5	75.5	97	113	125	135.5	144	154	163.5	176
8	34	50	62	86.5	109	124	136	147	155	165.5	174.5	186
6	49	64	76	101	123	138	150	160	168.5	179.5	188	199
4	68	85	95.5	120	142	157	168	177.5	186	196	204.5	216
2	100	116	128	151	171	186.5	197.5	207	215	224	232.5	244
1	131	147	157.5	181.5	200.5	215	225	234.5	243	250.5	260.5	270.5

**Measures for Comparing the Duty of Engines.** — Capacity is measured in horse-powers, expressed by the initials, H.P.: 1 H.P.=33,000 ft.-lbs. per minute, = 550 ft.-lbs. per second, = 1,980,000 ft.-lbs. per hour. 1 ft.-lb. = a pressure of 1 lb. exerted through a space of 1 ft.

Economy is measured, 1, in pounds of coal per horse-power per hour; 2, in pounds of steam per horse-power per hour. The second of these measures is the more accurate and scientific, since the engine uses steam and not coal, and it is independent of the economy of the boiler. A still more accurate measure is the heat units per minute (or per hour) per horse-power.

In gas-engine tests the common measure is the number of cubic feet of gas (measured at atmospheric pressure) per horse-power, but as all gas is not of the same quality, it is necessary for comparison of tests to give the analysis of the gas. When the gas for one engine is made in one gas-producer, then the number of pounds of coal used in the producer per hour per horse-power of the engine is a measure of economy. Since different coals vary in heating value, a more accurate measure is the number of heat units required per horse-power per hour.

Economy, or duty of an engine, is also measured in the number of foot-pounds of work done per pound of fuel. As 1 horse-power is equal to 1,980,000 ft.-lbs. of work in an hour, a duty of 1 lb. of coal per H.P. per hour would be equal to 1,980,000 ft.-lbs. per lb. of fuel; 2 lbs. per H.P. per hour equals 990,000 ft.-lbs. per lb. of fuel, etc.

The duty of pumping-engines is expressed by the number of foot-pounds of work done per 100 lbs. of coal, per 1000 lbs. of steam, or per million heat units.

When the duty of a pumping-engine is given, in ft.-lbs. per 100 lbs. of coal, the equivalent number of pounds of fuel consumed per horse-power per hour is found by dividing 198 by the number of millions of foot-pounds of duty. Thus a pumping-engine giving a duty of 99 millions is equivalent to  $198/99 = 2$  lbs. of fuel per horse-power per hour.

**Efficiency Measured in Thermal Units per Minute.** — The efficiency of an engine is sometimes expressed in terms of the number of thermal units used by the engine per minute for each indicated horse-power, instead of by the number of pounds of steam used per hour.

The heat chargeable to an engine per pound of steam is the difference between the total heat in a pound of steam at the boiler-pressure and that in a pound of the feed-water entering the boiler. In the case of condensing engines, suppose we have a temperature in the hot-well of  $100^{\circ}$  F., corresponding to a vacuum of 28 in. of mercury; we may feed the water into the boiler at that temperature. In the case of a non-condensing engine, by using a portion of the exhaust steam in a good feed-water heater, at a pressure a trifle above the atmosphere (due to the resistance of the exhaust passages through the heater), we may obtain feed-water at  $212^{\circ}$ . One pound of steam used by the engine then would be equivalent to thermal units as follows:

Gauge pressure.....	50	75	100	125	150	175	200
Absolute pressure....	65	90	115	140	165	190	215
Total heat in steam above $32^{\circ}$ :							
	1178.5	1184.4	1188.8	1192.2	1195.0	1197.3	1199.2

Subtracting 68 and 180 heat-units, respectively, the heat above  $32^{\circ}$  in feed-water of  $100^{\circ}$  and  $212^{\circ}$  F., we have —

Heat given by boiler per pound of steam:

Feed at $100^{\circ}$ .....	1110.5	1116.4	1120.8	1124.2	1127.0	1129.3	1131.2
Feed at $212^{\circ}$ .....	998.5	1004.4	1008.8	1012.2	1015.0	1017.3	1019.2

Thermal units per minute used by an engine for each pound of steam used per indicated horse-power per hour:

Feed at $100^{\circ}$ .....	18.51	18.61	18.68	18.74	18.78	18.82	18.85
Feed at $212^{\circ}$ .....	16.64	16.76	16.78	16.87	16.92	16.96	16.99

**EXAMPLES.** — A triple-expansion engine, condensing, with steam at 175 lbs. gauge, and vacuum 28 in., uses 13 lbs. of water per I.H.P. per hour, and a high-speed non-condensing engine, with steam at 100 lbs. gauge, uses 30 lbs. How many thermal units per minute does each consume?

*Ans.* —  $13 \times 18.82 = 244.7$ , and  $30 \times 16.78 = 503.4$  thermal units per minute.

A perfect engine converting all the heat-energy of the steam into work would require  $33,000 \text{ ft.-lbs.} \div 777.54 = 42.44$  thermal units per minute per indicated horse-power. This figure, 42.44, therefore, divided by the number of thermal units per minute per I.H.P. consumed by an engine, gives its efficiency as compared with an ideally perfect engine. In the examples above, 42.44 divided by 244.7 and by 503.4 gives 17.34% and 8.43% efficiency, respectively.



**ACTUAL EXPANSIONS**  
**With Different Clearances and Cut-offs.**  
 Computed by A. F. Nagle.

Cut-off.	Per Cent of Clearance.										
	0	1	2	3	4	5	6	7	8	9	10
.01	100.00	50.5	34.0	25.75	20.8	17.5	15.14	13.38	12.00	10.9	10
.02	50.00	33.67	25.50	20.60	17.33	15.00	13.25	11.89	10.80	9.91	9.17
.03	33.33	25.25	20.40	17.16	14.86	13.12	11.78	10.70	9.82	9.08	8.46
.04	25.00	20.20	17.00	14.71	13.00	11.66	10.60	9.73	9.00	8.39	7.86
.05	20.00	16.83	14.57	12.87	11.55	10.50	9.64	8.92	8.31	7.79	7.33
.06	16.67	14.43	12.75	11.44	10.40	9.55	8.83	8.23	7.71	7.27	6.88
.07	14.28	12.62	11.33	10.30	9.46	8.75	8.15	7.64	7.20	6.81	6.47
.08	12.50	11.22	10.2	9.36	8.67	8.08	7.57	7.13	6.75	6.41	6.11
.09	11.11	10.10	9.27	8.58	8.00	7.50	7.07	6.69	6.35	6.06	5.79
.10	10.00	9.18	8.50	7.92	7.43	7.00	6.62	6.30	6.00	5.74	5.50
.11	9.09	8.42	7.84	7.36	6.93	6.56	6.24	5.94	5.68	5.45	5.24
.12	8.33	7.78	7.29	6.86	6.50	6.18	5.89	5.63	5.40	5.19	5.00
.14	7.14	6.73	6.37	6.06	5.78	5.53	5.30	5.10	4.91	4.74	4.58
.16	6.25	5.94	5.67	5.42	5.20	5.00	4.82	4.65	4.50	4.36	4.23
.20	5.00	4.81	4.64	4.48	4.33	4.20	4.08	3.96	3.86	3.76	3.67
.25	4.00	3.88	3.77	3.68	3.58	3.50	3.42	3.34	3.27	3.21	3.14
.30	3.33	3.26	3.19	3.12	3.06	3.00	2.94	2.90	2.84	2.80	2.75
.40	2.50	2.46	2.43	2.40	2.36	2.33	2.30	2.28	2.25	2.22	2.20
.50	2.00	1.98	1.96	1.94	1.92	1.90	1.89	1.88	1.86	1.85	1.83
.60	1.67	1.66	1.65	1.64	1.63	1.615	1.606	1.597	1.588	1.580	1.571
.70	1.43	1.42	1.42	1.41	1.41	1.400	1.395	1.390	1.385	1.380	1.375
.80	1.25	1.25	1.244	1.241	1.238	1.235	1.233	1.230	1.227	1.224	1.222
.90	1.111	1.11	1.109	1.108	1.106	1.105	1.104	1.103	1.102	1.101	1.100
1.00	1.00	1.00	1.000	1.000	1.000	1.000	1.000	1.000	1.000	1.000	1.000

**Relative Efficiency of 1 lb. of Steam with and without Clearance;**  
 back pressure and compression not considered.

$$\text{Mean total pressure} = p = \frac{P(l+c) + P(l+c) \text{ hyp log } R - Pc}{L}$$

Let  $P = 1$ ;  $L = 100$ ;  $l = 25$ ;  $c = 7$ .

$$p = \frac{32 + 32 \text{ hyp log } \frac{107}{32} - 7}{100} = \frac{32 + 32 \times 1.207 - 7}{100} = 0.636.$$

If the clearance be added to the stroke, so that clearance becomes zero, the same quantity of steam being used, admission  $l$  being then  $= l + c = 32$ , and stroke  $L + c = 107$ ,

$$p_1 = \frac{32 + 32 \text{ hyp log } \frac{107}{32} - 0}{107} = \frac{32 + 32 \times 1.207}{107} = 0.660.$$

The work of one stroke  $= p_1(L+c) = 0.660 \times 107 = 70.6$ . The amount of the clearance 7 being added to both admission and the stroke, the same quantity of steam will do more work than when the clearance is 7 in the ratio 706 : 636, or 11% more.

**Back Pressure Considered.**—If back pressure  $= 0.10$  of  $P$ , this amount has to be subtracted from  $p$  and  $p_1$  giving  $p = 0.536$ ,  $p_1 = 0.560$ , the work of a given quantity of steam used without clearance being greater than when clearance is 7% in the ratio  $(560 \times 1.07) : 536$ , or 12% more.

**Effect of Compression.**—By early closure of the exhaust, so that a portion of the exhaust-steam is compressed into the clearance-space, much of the loss due to clearance may be avoided. If expansion is continued down to the back pressure, if the back pressure is uniform throughout the exhaust-stroke, and if compression begins at such point that the

exhaust-steam remaining in the cylinder is compressed to the initial pressure at the end of the back stroke, then the work of compression of the exhaust-steam equals the work done during expansion by the clearance-steam. The clearance-space being filled by the exhaust-steam thus compressed, no new steam is required to fill the clearance-space for the next forward stroke, and the work and efficiency of the steam used in the cylinder are just the same as if there were no clearance and no compression. When, however, there is a drop in pressure from the final pressure of the expansion, or the terminal pressure, to the exhaust or back pressure (the usual case), the work of compression to the initial pressure is greater than the work done by the expansion of the clearance-steam, so that a loss of efficiency results. In this case a greater efficiency can be attained by inclosing for compression a less quantity of steam than that needed to fill the clearance-space with steam of the initial pressure. (See Clark, S. E., p. 399, *et seq.*; also F. H. Ball, *Trans. A. S. M. E.*, xiv, 1067.) It is shown by Clark that a somewhat greater efficiency is thus attained whether or not the pressure of the steam be carried down by expansion to the back exhaust-pressure.

Cylinder-condensation may have considerable effect upon the best point of compression, but it has not yet (1893) been determined by experiment. (*Trans. A. S. M. E.*, xiv, 1078.)

**Clearance in Low- and High-speed Engines.** (Harris Tabor, *Am. Mach.*, Sept. 17, 1891.) — The construction of the high-speed engine is such, with its relatively short stroke, that the clearance must be much larger than in the releasing-valve type. The short-stroke engine is, of necessity, an engine with large clearance, which is aggravated when variable compression is a feature. Conversely, the engine with releasing-valve gear is, from necessity, an engine of slow rotative speed, where great power is obtainable from long stroke, and small clearance is a feature in its construction. In one case the clearance will vary from 8% to 12% of the piston-displacement, and in the other from 2% to 3%. In the case of an engine with a clearance equaling 10% of the piston-displacement the waste room becomes enormous when considered in connection with an early cut-off. The system of compounding reduces the waste due to clearance in proportion as the steam is expanded to a lower pressure. The farther expansion is carried through a train of cylinders the greater will be the reduction of waste due to clearance. This is shown from the fact that the high-speed engine, expanding steam much less than the Corliss, will show a greater gain when changed from simple to compound than its rival under similar conditions.

**Cylinder-condensation.** — Rankine, S. E., p. 421, says: Conduction of heat to and from the metal of the cylinder, or to and from liquid water contained in the cylinder, has the effect of lowering the pressure at the beginning and raising it at the end of the stroke, the lowering effect being on the whole greater than the raising effect. In some experiments the quantity of steam wasted through alternate liquefaction and evaporation in the cylinder has been found to be greater than the quantity which performed the work.

#### Percentage of Loss by Cylinder-condensation, taken at Cut-off.

(From circular of the Ashcroft Mfg. Co. on the Tabor Indicator, 1889.)

Percentage of Stroke completed at Cut-off.	Per cent of Feed-water accounted for by the Indicator.			Per cent of Feed-water due to Cylinder-condensation.		
	Simple Engines.	Compound Engines, h.p. cyl.	Triple-expansion Engines, h.p. cyl.	Simple Engines.	Compound Engines, h.p. cyl.	Triple-expansion Engines, h.p. cyl.
5	58	.....	.....	42	.....	.....
10	66	74	.....	34	26	.....
15	71	76	78	29	24	22
20	74	78	80	26	22	20
30	78	82	84	22	18	16
40	82	85	87	18	15	13
50	86	88	90	14	12	10

**Theoretical Compared with Actual Water-consumption, Single-cylinder Automatic Cut-off Engines.** (From the catalogue of the Buckeye Engine Co.) — The following table has been prepared on the basis of the pressures that result in practice with a constant boiler-pressure of 80 lbs. and different points of cut-off, with Buckeye engines and others with similar clearance. Fractions are omitted, except in the percentage column, as the degree of accuracy their use would seem to imply is not attained or aimed at.

Cut-off Part of Stroke.	Mean Effective Pressure, lbs. per sq. in.	Total Terminal Pressure, lbs. per sq. in.	Indicated Rate, lbs. Water per I.H.P. per hour.	Assumed.		Product of Cols. 1 and 6.
				Act'l Rate.	% Loss.	
0.10	18	11	20	32	58	5.8
0.15	27	15	19	27	41	6.15
0.20	35	20	19	25	31.5	6.3
0.25	42	25	20	25	25	6.25
0.30	48	30	20	24	21.8	6.54
0.35	53	35	21	25	19	6.65
0.40	57	38	22	26	16.7	6.68
0.45	61	43	23	27	15	6.75
0.50	64	48	24	27	13.6	6.8

It will be seen that while the best indicated economy is when the cut-off is about at 0.15 or 0.20 of the stroke, giving about 30 lbs. M.E.P., and a terminal 3 or 4 lbs. above atmosphere, when we come to add the percentages due to a constant amount of unindicated loss, as per sixth column, the most economical point of cut-off is found to be about 0.30 of the stroke, giving 48 lbs. M.E.P. and 30 lbs. terminal pressure. This showing agrees substantially with modern experience under automatic cut-off regulation.

The last column shows that the actual amount of cylinder condensation is nearly a constant quantity, increasing only from 5.8% of the cylinder volume at 0.10 cut-off to 6.8% at 0.50 cut-off.

**Experiments on Cylinder-condensation.** — Experiments by Major Thos. English (*Eng'g*, Oct. 7, 1887, p. 386) with an engine 10 × 14 in., jacketed in the sides but not on the ends, indicate that the net initial condensation (or excess of condensation over re-evaporation) by the clearance surface varies directly as the initial density of the steam, and inversely as the square root of the number of revolutions per unit of time. The mean results gave for the net initial condensation by clearance-space per sq. ft. of surface at one rev. per second 6.06 thermal units in the engine when run non-condensing and 5.75 units when condensing.

G. R. Bodmer (*Eng'g*, March 4, 1892, p. 299) says: Within the ordinary limits of expansion desirable in one cylinder the expansion ratio has practically no influence on the amount of condensation per stroke, which for simple engines can be expressed by the following formula for the weight of water condensed [per minute, probably; the original does not state]:  $W = C \frac{S(T-t)}{L \sqrt[3]{N^2}}$ , where  $T$  denotes the mean admission temper-

ature,  $t$  the mean exhaust temperature,  $S$  clearance-surface (square feet),  $N$  the number of revolutions per second,  $L$  latent heat of steam at the mean admission temperature, and  $C$  a constant for any given type of engine.

Mr. Bodmer found from experimental data that for high-pressure non-jacketed engines  $C =$  about 0.11, for condensing non-jacketed engines 0.085 to 0.11, for condensing jacketed engines 0.085 to 0.053. The figures for jacketed engines apply to those jacketed in the usual way, and not at the ends.

$C$  varies for different engines of the same class, but is practically constant for any given engine. For simple high-pressure non-jacketed engines it was found to range from 0.1 to 0.112.

Applying Mr. Bodmer's formula to the case of a Corliss non-jacketed



non-condensing engine, 4-ft. stroke, 24 in. diam., 60 revs. per min., initial pressure 90 lbs. gauge, exhaust pressure 2 lbs., we have  $T - t = 112^\circ$ ,  $N = 1$ ,  $L = 880$ ,  $S = 7$  sq. ft.; and, taking  $C = 0.112$  and  $W =$  lbs. water condensed per minute,  $W = \frac{0.112 \times 112 \times 7}{1 \times 880} = 0.09$  lb. per minute, or 5.4 lbs. per hour. If the steam used per I.H.P. per hour according to the diagram is 20 lbs., the actual water consumption is 25.4 lbs., corresponding to a cylinder condensation of 27%.

### INDICATOR-DIAGRAM OF A SINGLE-CYLINDER ENGINE.

**Definitions.** — *The Atmospheric Line, AB*, is a line drawn by the pencil of the indicator when the connections with the engine are closed and both sides of the piston are open to the atmosphere.

*The Vacuum Line, OX*, is a reference line usually drawn about 14.7 pounds by scale below the atmospheric line.

*The Clearance Line, OY*, is a reference line drawn at a distance from the end of the diagram equal to the same per cent of its length as the clearance and waste room is of the piston-displacement.

*The Line of Boiler-pressure, JK*, is drawn parallel to the

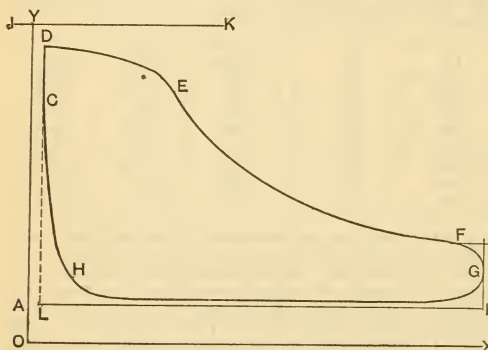

FIG. 162.

atmospheric line, and at a distance from it by scale equal to the boiler-pressure shown by the gauge.

*The Admission Line, CD*, shows the rise of pressure due to the admission of steam to the cylinder by opening the steam-valve.

*The Steam Line, DE*, is drawn when the steam-valve is open and steam is being admitted to the cylinder.

*The Point of Cut-off, E*, is the point where the admission of steam is stopped by the closing of the valve. It is often difficult to determine the exact point at which the cut-off takes place. It is usually located where the outline of the diagram changes its curvature from convex to concave.

*The Expansion Curve, EF*, shows the fall in pressure as the steam in the cylinder expands doing work.

*The Point of Release, F*, shows when the exhaust-valve opens.

*The Exhaust Line, FG*, represents the change in pressure that takes place when the exhaust-valve opens.

*The Back-pressure Line, GH*, shows the pressure against which the piston acts during its return stroke.

*The Point of Exhaust Closure, H*, is the point where the exhaust-valve closes. It cannot be located definitely, as the change in pressure is at first due to the gradual closing of the valve.

*The Compression Curve, HC*, shows the rise in pressure due to the compression of the steam remaining in the cylinder after the exhaust-valve has closed.

*The Mean Height of the Diagram* equals its area divided by its length.

*The Mean Effective Pressure* is the mean net pressure urging the piston forward = the mean height  $\times$  the scale of the indicator-spring.

*To find the Mean Effective Pressure from the Diagram.* — Divide the length,  $LB$ , into a number, say 10, equal parts, setting off half a part at  $L$ , half a part at  $B$ , and nine other parts between; erect ordinates perpendicular to the atmospheric line at the points of division of  $LB$ , cutting the diagram; add together the lengths of these ordinates intercepted

between the upper and lower lines of the diagram and divide by their number. This gives the mean height, which multiplied by the scale of the indicator-spring gives the M.E.P. Or find the area by a planimeter, or other means (see Mensuration, p. 56), and divide by the length  $LB$  to obtain the mean height.

*The Initial Pressure* is the pressure acting on the piston at the beginning of the stroke.

*The Terminal Pressure* is the pressure above the line of perfect vacuum that would exist at the end of the stroke if the steam had not been released earlier. It is found by continuing the expansion-curve to the end of the diagram.

A single indicator card shows the pressure exerted by the steam at each instant on one side of the piston; a card taken simultaneously from the opposite end of the engine shows the pressure exerted on the other side. By superposing these cards the pressure or tension on the piston rod may be determined. The pressure or pull on the crank pin at any instant is the pressure or tension in the rod modified by the angle of the connecting rod and by the effect of the inertia of the reciprocating parts. For discussion of this subject see Klein's "High-speed Steam Engine," also papers by S. A. Moss, *Trans. A. S. M. E.*, 1904, and by F. W. Hollmann, in *Power*, April 6, 1909.

**Errors of Indicators.** — The most common error is that of the spring, which may vary from its normal rating; the error may be determined by proper testing apparatus and allowed for. But after making this correction, even with the best work, the results are liable to variable errors which may amount to 2 or 3 per cent. See Barrus, *Trans. A. S. M. E.*, v, 310; Denton, *Trans. A. S. M. E.*, xi, 329; David Smith, U. S. N., *Proc. Eng'g Congress*, 1893, Marine Division.

Other errors of indicator diagrams are those due to inaccuracy of the straight-line motion of the indicator, to the incorrect design or position of the "rig" or reducing motion, to long pipes between the indicator and the engine, to throttling of these pipes, to friction or lost motion in the indicator mechanism, and to drum-motion distortion. For discussion of the last named see *Power*, April, 1909. For methods of testing indicators, see paper by D. S. Jacobus, *Trans. A. S. M. E.*, 1898.

Indicator "Rigs," or Reducing-motions; Interpretation of Diagrams for Errors of Steam-distribution, etc. For these see circulars of manufacturers of Indicators; also works on the Indicator.

**Pendulum Indicator Rig.** — *Power* (Feb., 1893) gives a graphical representation of the errors in indicator-diagrams, caused by the use of incorrect forms of the pendulum rigging. It

is shown that the "brumbo" pulley on the pendulum, to which the cord is attached, does not generally give as good a reduction as a simple pin attachment. When the end of the pendulum is slotted, working in a pin on the crosshead, the error is apt to be considerable at both ends of the card. With a vertical slot in a plate fixed to the crosshead, and a pin on the pendulum working in this slot, the reduction is perfect, when the cord is attached to a pin on the pendulum, a slight error being introduced if the brumbo pulley is used. With the connection between the pendulum and the crosshead made by means of a horizontal link, the reduction is nearly perfect, if the construction is such that the connecting link vibrates equally above and below the horizontal, and the cord is attached by a pin. If the link is horizontal at mid-stroke a serious error is introduced, which is magnified if a brumbo pulley also is used. The adjoining figures show the two forms recommended.

**The Manograph**, for indicating engines of very high speed, invented by Prof. Hospitalier, is described by Howard Greene in *Power*, June, 1907. It is made by Carpentier, of Paris. A small mirror is tilted upward and downward by a diaphragm which responds to the pressure variations in the cylinder, and the same mirror is rocked from side to side by a reducing mechanism which is geared to the engine and reproduces the reciprocations

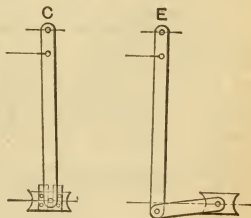

FIG. 163.

of the engine piston on a smaller scale. A beam of light is reflected by the mirror to the ground-glass screen, and this beam, by the oscillations of the mirror, is made to traverse a path corresponding to that of the pencil point of an ordinary indicator. The diagram, therefore, is made continuously but varies with varying conditions in the cylinder.

A plate-holder carrying a photographic dry plate can be substituted for the ground-glass screen, and the diagram photographed, the exposure required varying from half a second to three seconds. By the use of special diaphragms and springs the effects of low pressures and vacuums can be magnified, and thus the instrument can be made to show with remarkable clearness the action of the valves of a gas engine on the suction and exhaust strokes.

**The Lea Continuous Recorder**, for recording the steam consumption of an engine, is described by W. H. Booth in *Power*, Aug. 31, 1909. It comprises a tank into which flows the condensed steam from a condenser, a triangular notch through which the water flows from the tank, and a mechanical device through which the variations in the level of the water in the tank are translated into the motion of a pencil, which motion is made proportionate to the quantity flowing, and is recorded on paper moved by clockwork.

### INDICATED HORSE-POWER OF ENGINES, SINGLE-CYLINDER.

$$\text{Indicated Horse-power, I.H.P.} = \frac{P L a n}{33,000},$$

in which  $P$  = mean effective pressure in lbs. per sq. in.;  $L$  = length of stroke in feet;  $a$  = area of piston in square inches. For accuracy, one half of the sectional area of the piston-rod must be subtracted from the area of the piston if the rod passes through one head, or the whole area of the rod if it passes through both heads:  $n$  = No. of single strokes per min. =  $2 \times$  No. of revolutions of a double-acting engine.

$$\text{I.H.P.} = \frac{P a S}{33,000}, \text{ in which } S = \text{piston speed in feet per minute.}$$

$$\text{I.H.P.} = \frac{P L d^2 n}{42,017} = \frac{P d^2 S}{42,017} = 0.0000238 P L d^2 n = 0.0000238 P d^2 S,$$

in which  $d$  = diam. of cyl. in inches. (The figures 238 are exact, since  $7854 \div 33 = 23.8$  exactly.) If product of piston-speed  $\times$  mean effective pressure = 42,017, then the horse-power would equal the square of the diameter in inches.

**Handy Rule for Estimating the Horse-power of a Single-cylinder Engine.** — Square the diameter and divide by 2. This is correct whenever the product of the mean effective pressure and the piston-speed =  $\frac{1}{2}$  of 42,017, or, say, 21,000, viz., when M.E.P. = 30 and  $S = 700$ ; when M.E.P. = 35 and  $S = 600$ ; when M.E.P. = 38.2 and  $S = 550$ ; and when M.E.P. = 42 and  $S = 500$ . These conditions correspond to those of ordinary practice with both Corliss engines and shaft-governor high-speed engines.

**Given Horse-power, Mean Effective Pressure, and Piston-speed, to find Size of Cylinder.** —

$$\text{Area} = \frac{33,000 \times \text{I.H.P.}}{P L n} \quad \text{Diameter} = 205 \sqrt{\frac{\text{I.H.P.}}{P S}}$$

**Brake Horse-power** is the actual horse-power of the engine as measured at the fly-wheel by a friction-brake or dynamometer. It is the indicated horse-power minus the friction of the engine.

**Electrical Horse-power** is the power in an electric current, usually measured in kilowatts, translated into horse-power. 1 H.P. = 33,000 ft. lbs. per min.; 1 K.W. = 1.3405 H.P.; 1 H.P. = 0.746 kilowatts, or 746 watts.

**EXAMPLE.** — A 100-H.P. engine, with a friction loss of 10% at rated load, drives a generator whose efficiency is 90%, furnishing current to a motor of 90% effy., through a line whose loss is 5%. I.H.P. = 100; B.H.P. = 90; E.H.P. at generator 81, at end of line 76.95. H.P. delivered by motor 69.26.



**Table for Roughly Approximating the Horse-power of a Compound Engine from the Diameter of its Low-pressure Cylinder. —**

The indicated horse-power of an engine being  $\frac{Psd^2}{42,017}$ , in which  $P$  = mean effective pressure per sq. in.,  $s$  = piston-speed in ft. per min., and  $d$  = diam. of cylinder in inches; if  $s = 600$  ft. per min., which is approximately the speed of modern stationary engines, and  $P = 35$  lbs., which is an approximately average figure for the M.E.P. of single-cylinder engines, and of compound engines referred to the low-pressure cylinder, then I.H.P. =  $\frac{1}{2}d^2$ ; hence the rough-and-ready rule for horse-power given above: Square the diameter in inches and divide by 2. This applies to triple and quadruple expansion engines as well as to single cylinder and compound. For most economical loading, the M.E.P. referred to the low-pressure cylinder of compound engines is usually not greater than that of simple engines; for the greater economy is obtained by a greater number of expansions of steam of higher pressures, and the greater the number of expansions for a given initial pressure the lower the mean effective pressure. The following table gives approximately the figures of mean total and effective pressures for the different types of engines, together with the factor by which the square of the diameter is to be multiplied to obtain the horse-power at most economical loading, for a piston-speed of 600 ft. per minute.

Type of Engine.	Initial Absolute Steam-Pressure.	Number of Expansions.	Terminal Absolute Press., lbs.	Ratio Mean Total to Initial Pressure.	Mean Total Pressure, lbs.	Total Back Pressure, Mean, lbs.	Mean Effective Pressure, lbs.	Piston-speed, ft. per min.	Horse-power = diam. <sup>2</sup> ×
Non-condensing.									
Single Cylinder..	100	5.	20	0.522	52.2	15.5	36.7	600	0.524
Compound.....	120	7.5	16	.402	48.2	15.5	32.7	"	.467
Triple.....	160	10.	16	.330	52.8	15.5	37.3	"	.533
Quadruple.....	200	12.5	16	.282	56.4	15.5	40.9	"	.584
Condensing Engines.									
Single Cylinder..	100	10.	10	0.330	33.0	2	31.0	600	0.443
Compound.....	120	15.	8	.247	29.6	2	27.6	"	.390
Triple.....	160	20.	8	.200	32.0	2	30.0	"	.429
Quadruple.....	200	25.	8	.169	33.8	2	31.8	"	.454

For any other piston-speed than 600 ft. per min., multiply the figures in the last column by the ratio of the piston-speed to 600 ft.

**Horse-power Constant of a given Engine for a Fixed Speed** = product of its area of piston in square inches, length of stroke in feet and number of single strokes per minute divided by 33,000, or  $\frac{Lan}{33,000}$  =  $C$ . The product of the mean effective pressure as found by the diagram and this constant is the indicated horse-power.

**Horse-power Constant of any Engine of a given Diameter of Cylinder**, whatever the length of stroke, = area of piston ÷ 33,000 = square of the diameter of piston in inches × 0.0000238. A table of constants derived from this formula is given on page 943.

The constant multiplied by the piston-speed in feet per minute and by the M.E.P. gives the I.H.P.

**Table of Engine Constants for Use in Figuring Horse-power. —** "Horse-power constant" for cylinders from 1 inch to 60 inches in diameter, advancing by 8ths, for one foot of piston-speed per minute and one pound of M.E.P. Find the diameter of the cylinder in the column at the side. If the diameter contains no fraction the constant will be found in the column headed Even Inches. If the diameter is not in even inches, follow the line horizontally to the column corresponding to the required fraction. The constants multiplied by the piston-speed and by the M.E.P. give the horse-power.

Engine Constants, Constant  $\times$  Piston Speed  $\times$  M.E.P. = H.P.

Diam. of Cylinder.	Even Inches.	+ 1/8	+ 1/4	+ 3/8	+ 1/2	+ 5/8	+ 3/4	+ 7/8
1	.0000238	.0000301	.0000372	.0000450	.0000535	.0000628	.0000729	.0000837
2	.0000952	.0001074	.0001205	.0001342	.0001487	.0001640	.0001800	.0001967
3	.0002142	.0002324	.0002514	.0002711	.0002915	.0003127	.0003347	.0003574
4	.0003808	.0004050	.0004299	.0004554	.0004819	.0005091	.0005370	.0005656
5	.0005950	.0006251	.0006560	.0006876	.0007199	.0007530	.0007869	.0008215
6	.0008568	.0008929	.0009297	.0009672	.0010055	.0010445	.0010844	.0011249
7	.0011662	.0012082	.0012510	.0012944	.0013387	.0013837	.0014295	.0014759
8	.0015232	.0015711	.0016198	.0016693	.0017195	.0017705	.0018222	.0018746
9	.0019278	.0019817	.0020363	.0020916	.0021479	.0022048	.0022625	.0023209
10	.0023800	.0024398	.0025004	.0025618	.0026239	.0026867	.0027502	.0028147
11	.0028798	.0029456	.0030121	.0030794	.0031475	.0032163	.0032859	.0033561
12	.0034272	.0034990	.0035714	.0036447	.0037187	.0037934	.0038690	.0039452
13	.0040222	.0040999	.0041783	.0042576	.0043375	.0044182	.0044997	.0045819
14	.0046648	.0047484	.0048328	.0049181	.0050039	.0050906	.0051780	.0052661
15	.0053550	.0054446	.0055349	.0056261	.0057179	.0058105	.0059039	.0059979
16	.0060928	.0061884	.0062847	.0063817	.0064795	.0065780	.0066774	.0067774
17	.0068782	.0069797	.0070819	.0071850	.0072887	.0073932	.0074985	.0076044
18	.0077112	.0078187	.0079268	.0080360	.0081452	.0082560	.0083672	.0084791
19	.0085918	.0087052	.0088193	.0089343	.0090499	.0091663	.0092835	.0094013
20	.0095200	.0096393	.0097594	.0098803	.0100019	.0101243	.0102474	.0103712
21	.0104958	.0106211	.0107472	.0108739	.0110015	.0111299	.0112589	.0113886
22	.0115192	.0116505	.0117825	.0119152	.0120487	.0121830	.0123179	.0124537
23	.0125902	.0127274	.0128654	.0130040	.0131435	.0132837	.0134247	.0135664
24	.0137088	.0138519	.0139959	.0141405	.0142859	.0144321	.0145789	.0147266
25	.0148750	.0150241	.0151739	.0153246	.0154759	.0156280	.0157809	.0159345
26	.0160888	.0162439	.0163997	.0165563	.0167135	.0168716	.0170304	.0171899
27	.0173502	.0175112	.0176729	.0178355	.0179988	.0181627	.0183275	.0184929
28	.0186592	.0188262	.0189939	.0191624	.0193316	.0195015	.0196722	.0198436
29	.0200158	.0201887	.0203634	.0205368	.0207119	.0208879	.0210645	.0212418
30	.0214200	.0215988	.0217785	.0219588	.0221399	.0223218	.0225044	.0226877
31	.0228718	.0230566	.0232422	.0234285	.0236155	.0238033	.0239919	.0241812
32	.0243712	.0245619	.0247535	.0249457	.0251387	.0253325	.0255269	.0257222
33	.0259182	.0261149	.0263124	.0265106	.0267095	.0269092	.0271097	.0273109
34	.0275128	.0277155	.0279189	.0281231	.0283279	.0285336	.0287399	.0289471
35	.0291550	.0293636	.0295729	.0297831	.0299939	.0302056	.0304179	.0306309
36	.0308448	.0310594	.0312747	.0314908	.0317075	.0319251	.0321434	.0323624
37	.0325822	.0328027	.0330239	.0332460	.0334687	.0336922	.0339165	.0341415
38	.0343672	.0345937	.0348209	.0350489	.0352775	.0355070	.0357372	.0359681
39	.0361998	.0364322	.0366654	.0368993	.0371339	.0373694	.0376055	.0378424
40	.0380800	.0383184	.0385575	.0387973	.0390379	.0392793	.0395214	.0397642
41	.0400078	.0402521	.0404972	.0407430	.0409895	.0412368	.0414849	.0417337
42	.0419832	.0422335	.0424845	.0427362	.0429887	.0432420	.0434959	.0437507
43	.0440062	.0442624	.0445194	.0447771	.0450355	.0452947	.0455547	.0458154
44	.0460768	.0463389	.0466019	.0468655	.0471299	.0473951	.0476609	.0479276
45	.0481950	.0484631	.0487320	.0490016	.0492719	.0495430	.0498149	.0500875
46	.0503608	.0506349	.0509097	.0511853	.0514615	.0517386	.0520164	.0522949
47	.0525742	.0528542	.0531349	.0534165	.0536988	.0539818	.0542655	.0545499
48	.0548352	.0551212	.0554079	.0556953	.0559835	.0562725	.0565622	.0568526
49	.0571438	.0574357	.0577284	.0580218	.0583159	.0586109	.0589065	.0592029
50	.0595000	.0597979	.0600965	.0603959	.0606959	.0609969	.0612984	.0616007
51	.0619038	.0622076	.0625122	.0628175	.0631235	.0634304	.0637379	.0640462
52	.0643552	.0646649	.0649753	.0652867	.0655987	.0659115	.0662250	.0665392
53	.0668542	.0671699	.0674864	.0678036	.0681215	.0684402	.0687597	.0690799
54	.0694008	.0697225	.0700449	.0703681	.0706923	.0710166	.0713419	.0716681
55	.0719950	.0724226	.0728510	.0732801	.0737099	.0741406	.0745719	.0750039
56	.0746368	.0749704	.0753047	.0756398	.0759755	.0763120	.0766494	.0769874
57	.0773262	.0776657	.0780060	.0783476	.0786887	.0790312	.0793745	.0797185
58	.0806332	.0804087	.0807549	.0811019	.0814495	.0817980	.0821472	.0824971
59	.0828478	.0831992	.0835514	.0839043	.0842579	.0846123	.0849675	.0853234
60	.0856800	.0860374	.0863955	.0867543	.0871139	.0874743	.0878354	.0881973

## Horse-power per Pound Mean Effective Pressure.

Formula, Area in sq. in.  $\times$  piston-speed  $\div$  33,000.

Diam of Cylinder, inches.	Speed of Piston in feet per minute.								
	100	200	300	400	500	600	700	800	900
4	.0381	.0762	.1142	.1523	.1904	.2285	.2666	.3046	.3427
4 1/2	.0482	.0964	.1446	.1928	.2410	.2892	.3374	.3856	.4338
5	.0595	.1190	.1785	.2380	.2975	.3570	.4165	.4760	.5355
5 1/2	.0720	.1440	.2160	.2880	.3600	.4320	.5040	.5760	.6480
6	.0857	.1714	.2570	.3427	.4284	.5141	.5998	.6854	.7711
6 1/2	.1006	.2011	.3017	.4022	.5028	.6033	.7039	.8044	.9050
7	.1166	.2332	.3499	.4665	.5831	.6997	.8163	.9330	1.0496
7 1/2	.1339	.2678	.4016	.5355	.6694	.8033	.9371	1.0710	1.2049
8	.1523	.3046	.4570	.6093	.7616	.9139	1.0662	1.2186	1.3709
8 1/2	.1720	.3439	.5159	.6878	.8598	1.0317	1.2037	1.3756	1.5476
9	.1928	.3856	.5783	.7711	.9639	1.1567	1.3495	1.5422	1.7350
9 1/2	.2148	.4296	.6444	.8592	1.0740	1.2888	1.5036	1.7184	1.9332
10	.2380	.4760	.7140	.9520	1.1900	1.4280	1.6660	1.9040	2.1420
11	.2880	.5760	.8639	1.1519	1.4399	1.7279	2.0159	2.3038	2.5818
12	.3427	.6854	1.0282	1.3709	1.7136	2.0563	2.3990	2.7418	3.0845
13	.4022	.8044	1.2067	1.6089	2.0111	2.4133	2.8155	3.2178	3.6200
14	.4665	.9330	1.3994	1.8659	2.3324	2.7989	3.2654	3.7318	4.1983
15	.5355	1.0710	1.6065	2.1420	2.6775	3.2130	3.7485	4.2840	4.8195
16	.6093	1.2186	1.8278	2.4371	3.0464	3.6557	4.2650	4.8742	5.4835
17	.6878	1.3756	2.0635	2.7513	3.4391	4.1269	4.8147	5.5026	6.1904
18	.7711	1.5422	2.3134	3.0845	3.8556	4.6267	5.3978	6.1690	6.9401
19	.8592	1.7184	2.5775	3.4367	4.2959	5.1551	6.0143	6.8734	7.7326
20	.9520	1.9040	2.8560	3.8080	4.7600	5.7120	6.6640	7.6160	8.5680
21	1.0496	2.0992	3.1488	4.1983	5.2479	6.2975	7.3471	8.3966	9.4462
22	1.1519	2.3038	3.4558	4.6077	5.7596	6.9115	8.0634	9.2154	10.367
23	1.2590	2.5180	3.7771	5.0361	6.2951	7.5541	8.8131	10.072	11.331
24	1.3709	2.7418	4.1126	5.4835	6.8544	8.2253	9.5962	10.967	12.338
25	1.4875	2.9750	4.4625	5.9500	7.4375	8.9250	10.413	11.900	13.388
26	1.6089	3.2178	4.8266	6.4355	8.0444	9.6534	11.262	12.871	14.480
27	1.7350	3.4700	5.2051	6.9401	8.6751	10.410	12.145	13.880	15.615
28	1.8659	3.7318	5.5978	7.4637	9.3296	11.196	13.061	14.927	16.793
29	2.0016	4.0032	6.0047	8.0063	10.008	12.009	14.011	16.013	18.014
30	2.1420	4.2840	6.4260	8.5680	10.710	12.852	14.994	17.136	19.278
31	2.2872	4.5744	6.8615	9.1487	11.436	13.723	16.010	18.297	20.585
32	2.4371	4.8742	7.3114	9.7485	12.186	14.623	17.060	19.497	21.934
33	2.5918	5.1836	7.7755	10.367	12.959	15.551	18.143	20.735	23.326
34	2.7513	5.5026	8.2538	11.005	13.756	16.508	19.259	22.010	24.762
35	2.9155	5.8310	8.7465	11.662	14.578	17.493	20.409	23.324	26.240
36	3.0845	6.1690	9.2534	12.338	15.422	18.507	21.591	24.676	27.760
37	3.2582	6.5164	9.7747	13.033	16.291	19.549	22.808	26.066	29.324
38	3.4367	6.8734	10.310	13.747	17.184	20.620	24.057	27.494	30.930
39	3.6200	7.2400	10.860	14.480	18.100	21.720	25.340	28.960	32.580
40	3.8080	7.6160	11.424	15.232	19.040	22.848	26.656	30.464	34.272
41	4.0008	8.0016	12.002	16.003	20.004	24.005	28.005	32.006	36.007
42	4.1983	8.3866	12.585	16.783	20.982	25.180	29.378	33.577	37.775
43	4.4006	8.8012	13.202	17.602	22.003	26.404	30.804	35.205	39.606
44	4.6077	9.2154	13.823	18.431	23.038	27.646	32.254	36.861	41.469
45	4.8195	9.6390	14.459	19.278	24.098	28.917	33.737	38.556	43.376
46	5.0361	10.072	15.108	20.144	25.180	30.216	35.253	40.289	45.325
47	5.2574	10.515	15.772	21.030	26.287	31.545	36.802	42.059	47.317
48	5.4835	10.967	16.451	21.934	27.418	32.901	38.385	43.868	49.352
49	5.7144	11.429	17.143	22.858	28.572	34.286	40.001	45.715	51.429
50	5.9500	11.900	17.850	23.800	29.750	35.700	41.650	47.600	53.550
51	6.1904	12.381	18.571	24.762	30.952	37.142	43.333	49.523	55.713
52	6.4355	12.871	19.307	25.742	32.178	38.613	45.049	51.484	57.920
53	6.6854	13.371	20.056	26.742	33.427	40.113	46.798	53.483	60.169
54	6.9401	13.880	20.820	27.760	34.700	41.640	48.581	55.521	62.461
55	7.1995	14.399	21.599	28.798	35.998	43.197	50.397	57.596	64.796
56	7.4637	14.927	22.391	29.855	37.318	44.782	52.246	59.709	67.173
57	7.7326	15.465	23.198	30.930	38.663	46.396	54.128	61.861	69.597
58	8.0063	16.013	24.019	32.025	40.032	48.038	56.044	64.051	72.054
59	8.2848	16.570	24.854	33.139	41.424	49.709	57.993	66.278	74.563
60	8.5680	17.136	25.704	34.272	42.840	51.408	59.976	68.544	77.112



**Nominal Horse-power.**— The term "nominal horse-power" originated in the time of Watt, and was used to express approximately the power of an engine as calculated from its diameter, estimating the mean pressure in the cylinder at 7 lbs. above the atmosphere. It has long been obsolete.

**Horse-power Constant of a given Engine for Varying Speeds** = product of its area of piston and length of stroke divided by 33,000. This multiplied by the mean effective pressure and by the number of single strokes per minute is the indicated horse-power.

**To draw the Clearance-line on the Indicator-diagram,** the actual clearance not being known. — The clearance-line may be obtained approximately by drawing a straight line, *cbad*, across the compression

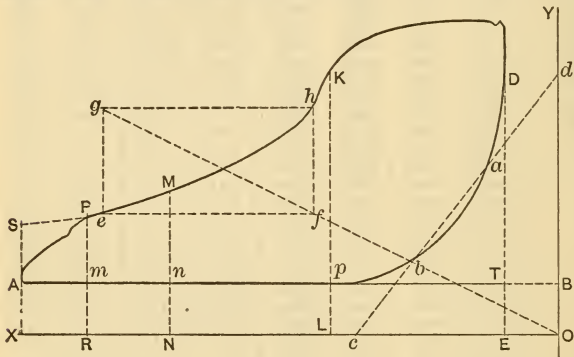

FIG. 164.

curve, first having drawn *OX* parallel to the atmospheric line and 14.7 lbs. below. Measure from *a* the distance *ad*, equal to *cb*, and draw *YO* perpendicular to *OX* through *d*; then will *TB* divided by *AT* be the percentage of clearance. The clearance may also be found from the expansion-line by constructing a rectangle *efhg*, and drawing a diagonal *gf* to intersect the line *XO*. This will give the point *O*, and by erecting a perpendicular to *XO* we obtain a clearance-line *OY*.

Both these methods for finding the clearance require that the expansion and compression curves be hyperbolas. Prof. Carpenter (*Power*, Sept., 1893) says that with good diagrams the methods are usually very accurate, and give results which check substantially.

The Buckeye Engine Co., however, says that, as the results obtained are seldom correct, being sometimes too little, but more frequently too much, and as the indications from the two curves seldom agree, the operation has little practical value, though when a clearly defined and apparently undistorted compression curve exists of sufficient extent to admit of the application of the process, it may be relied on to give much more correct results than the expansion curve.

**To draw the Hyperbolic Curve on the Indicator-diagram.** — Select

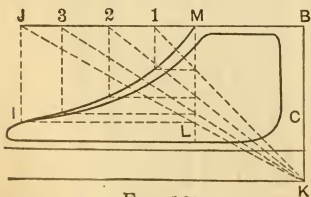

FIG. 165.

any point *I* in the actual curve, and from this point draw a line perpendicular to the line *JB*, meeting the latter in the point *J*. The line *JB* may be the line of boiler-pressure, but this is not material; it may be drawn at any convenient height near the top of the diagram and parallel to the atmospheric line. From *J* draw a diagonal to *K*, the latter point being the intersection of the vacuum and clearance lines; from *I* draw *IL* parallel with the atmospheric line. From *L*, the point of intersection of the diagonal *JK* and the horizontal line *IL*, draw the verti-

cal line  $LM$ . The point  $M$  is the theoretical point of cut-off, and  $LM$  the cut-off line. Fix upon any number of points 1, 2, 3, etc., on the line  $JB$ , and from these points draw diagonals to  $K$ . From the intersection of these diagonals with  $LM$  draw horizontal lines, and from 1, 2, 3, etc., vertical lines. Where these lines meet will be points in the hyperbolic curve.

**Theoretical Water-consumption calculated from the Indicator-card.**—The following method is given by Prof. Carpenter (*Power*, Sept., 1893):  $p$  = mean effective pressure,  $l$  = length of stroke in feet,  $a$  = area of piston in square inches,  $a \div 144$  = area in square feet,  $c$  = percentage of clearance to the stroke,  $b$  = percentage of stroke at point where water rate is to be computed,  $n$  = number of strokes per minute,  $60n$  = number per hour,  $w$  = weight of a cubic foot of steam having a pressure as shown by the diagram corresponding to that at the point where water rate is required,  $w'$  = that corresponding to pressure at end of compression.

$$\text{Number of cubic feet per stroke} = l \left( \frac{b+c}{100} \right) \frac{a}{144}$$

$$\text{Corresponding weight of steam per stroke in lbs.} = l \left( \frac{b+c}{100} \right) \frac{a}{144} w$$

$$\text{Volume of clearance} = \frac{lca}{14,400}$$

$$\text{Weight of steam in clearance} = \frac{lcaw'}{14,400}$$

$$\text{Total weight of steam per stroke} = l \left( \frac{b+c}{100} \right) \frac{wa}{144} - \frac{lcaw'}{14,400} = \frac{la}{14,400} [(b+c)w - cw']$$

$$\text{Total weight of steam from diagram per hour} = \frac{60nla}{14,400} [(b+c)w - cw']$$

The indicated horse-power is  $p l a n \div 33,000$ . Hence the steam-consumption per hour per indicated horse-power is

$$\frac{\frac{60nla}{14,400} [(b+c)w - cw']}{p l a n \div 33,000} = \frac{137.50}{p} [(b+c)w - cw']$$

Changing the formula to a rule, we have: To find the water rate from the indicator diagram at any point in the stroke.

**RULE.**—To the percentage of the entire stroke which has been completed by the piston at the point under consideration add the percentage of clearance. Multiply this result by the weight of a cubic foot of steam, having a pressure of that at the required point. Subtract from this the product of percentage of clearance multiplied by weight of a cubic foot of steam having a pressure equal to that at the end of the compression. Multiply this result by 137.50 divided by the mean effective pressure.\*

**NOTE.**—This method applies only to points in the expansion curve or between cut-off and release.

The beneficial effect of compression in reducing the water-consumption of an engine is clearly shown by the formula. If the compression is carried to such a point that it produces a pressure equal to that at the point under consideration, the weight of steam per cubic foot is equal, and  $w = w'$ . In this case the effect of clearance entirely disappears, and the formula becomes  $137.5 (bw) \div p$ .

In case of no compression,  $w'$  becomes zero, and the water-rate =

$$137.5 [(b+c)w] \div p$$

Prof. R. C. Carpenter (*Sibley Jour. of Eng'g*, Dec., 1910) states that tests of engines show that economy is really decreased by high compression. Armand Duchesne (*Power*, Jan. 10, 1911) gives as a reason for this that the steam undergoing compression is superheated and the work of compressing the superheated steam is greater than the work which it gives out later when it is in the condition of saturated steam.

\* For compound or triple-expansion engines read: divided by the equivalent mean effective pressure, on the supposition that all work is done in one cylinder.

Prof. Denton (*Trans. A. S. M. E.*, xiv, 1363) gives the following table of theoretical water-consumption for a perfect Mariotte expansion with steam at 150 lbs. above atmosphere, and 2 lbs. absolute back pressure:

Ratio of Expansion, <i>r</i> .	M.E.P., lbs. per sq. in.	Lbs. of Water per hour per horse-power, <i>W</i> .
10	52.4	9.68
15	38.7	8.74
20	30.9	8.20
25	25.9	7.84
30	22.2	7.63
35	19.5	7.45

The difference between the theoretical water-consumption found by the formula and the actual consumption as found by test represents "water not accounted for by the indicator," due to cylinder condensation, leakage through ports, radiation, etc.

**Leakage of Steam.** — Leakage of steam, except in rare instances, has so little effect upon the lines of the diagram that it can scarcely be detected. The only satisfactory way to determine the tightness of an engine is to take it when not in motion, apply a full boiler-pressure to the valve, placed in a closed position, and to the piston as well, which is blocked for the purpose at some point away from the end of the stroke, and see by the eye whether leakage occurs. The indicator-cocks provide means for bringing into view steam which leaks through the steam-valves, and in most cases that which leaks by the piston, and an opening made in the exhaust-pipe or observations at the atmospheric escape-pipe, are generally sufficient to determine the fact with regard to the exhaust-valves.

The steam accounted for by the indicator should be computed for both the cut-off and the release points of the diagram. If the expansion-line departs much from the hyperbolic curve a very different result is shown at one point from that shown at the other. In such cases the extent of the loss occasioned by cylinder condensation and leakage is indicated in a much more truthful manner at the cut-off than at the release. (Tabor Indicator Circular.)

## COMPOUND ENGINES.

**Compound, Triple- and Quadruple-expansion Engines.** — A compound engine is one having two or more cylinders, and in which the steam after doing work in the first or high-pressure cylinder completes its expansion in the other cylinder or cylinders.

The term "compound" is commonly restricted, however, to engines in which the expansion takes place in two stages only — high and low pressure, the terms triple-expansion and quadruple-expansion engines being used when the expansion takes place respectively in three and four stages. The number of cylinders may be greater than the number of stages of expansion, for constructive reasons; thus in the compound or two-stage expansion engine the low-pressure stage may be effected in two cylinders so as to obtain the advantages of nearly equal sizes of cylinders and of three cranks at angles of 120°. In triple-expansion engines there are frequently two low-pressure cylinders, one of them being placed tandem with the high-pressure, and the other with the intermediate cylinder, as in mill engines with two cranks at 90°. In the triple-expansion engines of the steamers *Camrnia* and *Lucania*, with three cranks at 120°, there were five cylinders, two high, one intermediate, and two low, the high-pressure cylinders being tandem with the low.

**Advantages of Compounding.** — The advantages secured by dividing the expansion into two or more stages are twofold: 1. Reduction of wastes of steam by cylinder-condensation, clearance, and leakage; 2. Dividing the pressures on the cranks, shafts, etc., in large engines so as to avoid excessive pressures and consequent friction. The diminished



loss by cylinder-condensation is effected by decreasing the range of temperature of the metal surfaces of the cylinders, or the difference of temperature of the steam at admission and exhaust. When high-pressure steam is admitted into a single-cylinder engine a large portion is condensed by the comparatively cold metal surfaces; at the end of the stroke and during the exhaust the water is re-evaporated, but the steam so formed escapes into the atmosphere or into the condenser, doing no work; while if it is taken into a second cylinder, as in a compound engine, it does work. The steam lost in the first cylinder by leakage and clearance also does work in the second cylinder. Also, if there is a second cylinder, the temperature of the steam exhausted from the first cylinder is higher than if there is only one cylinder, and the metal surfaces therefore are not cooled to the same degree. The difference in temperatures and in pressures corresponding to the work of steam of 150 lbs. gauge-pressure expanded 20 times, in one, two, and three cylinders, is shown in the following table, by W. H. Weightman, *Am. Mach.*, July 28, 1892:

	Single Cyl-inder.	Compound Cylinders.		Triple-expansion Cylinders.		
Diameter of cylinders, in. . . . .	60	33	61	28	46	61
Area ratios. . . . .		1	3.416	1	2.70	4.740
Expansions. . . . .	20	5	4	2.714	2.714	2.714
Initial steam-pressures — absolute — pounds. . . . .	165	165	33	165	60.8	22.4
Mean pressures, pounds. . . . .	32.96	86.11	19.68	121.44	44.75	16.49
Mean effective pressures, pounds. . . . .	28.96	53.11	15.68	60.64	22.35	12.49
Steam temperatures into cylinders. . . . .	366°	366°	259.9°	366°	293.5°	234.1°
Steam temperatures out of the cylinders. . . . .	184.2°	259.9°	184.2°	293.5°	234.1°	184.2°
Difference in temperatures	181.8	106.1	75.7	72.5	59.4	49.9

**“Woolf” and Receiver Types of Compound Engines.**—The compound steam-engine, consisting of two cylinders, is reducible to two forms, 1, in which the steam from the h.p. cylinder is exhausted direct into the l.p. cylinder, as in the Woolf engine; and 2, in which the steam from the h.p. cylinder is exhausted into an intermediate reservoir, whence the steam is supplied to, and expanded in, the l.p. cylinder, as in the “receiver-engine.”

If the steam be cut off in the first cylinder before the end of the stroke, the total ratio of expansion is the product of the two ratios of expansion; that is, the product of the ratio of expansion in the first cylinder, into the ratio of the volume of the second to that of the first cylinder.

Thus, let the areas of the first and second cylinders be as 1 to 3<sup>1</sup>/<sub>2</sub>, the strokes being equal, and let the steam be cut off in the first at 1/2 stroke; then

Expansion in the 1st cylinder . . . . .	1 to 2
Expansion in the 2d cylinder. . . . .	1 to 3 <sup>1</sup> / <sub>2</sub>

Total or combined expansion, the product of the two ratios 1 to 7

**Woolf Engine, without Clearance — Ideal Diagrams.**—The diagrams of pressure of an ideal Woolf engine are shown in Fig. 166, as they would be described by the indicator, according to the arrows. In these diagrams *pq* is the atmospheric line, *mn* the vacuum line, *cd* the admission line, *dg* the hyperbolic curve of expansion in the first cylinder, and *gh* the consecutive expansion-line of back pressure for the return-stroke of the first piston, and of positive pressure for the steam-stroke of the second piston. At the point *h*, at the end of the stroke of the second piston, the steam is exhausted into the condenser, and the pressure falls to the level of perfect vacuum, *mn*.

The diagram of the second cylinder, below *gh*, is characterized by the absence of any specific period of admission; the whole of the steam-line *gh* being expansive, generated by the expansion of the initial body of steam contained in the first cylinder into the second. When the return-stroke is completed, the whole of the steam transferred from the first is shut into the second cylinder. The final pressure and volume of the steam in the second cylinder are the same as if the whole of the initial steam had been admitted at once into the second cylinder, and then expanded to the end of the stroke in the manner of a single-cylinder engine. The net work of the steam is also the same, according to both distributions.

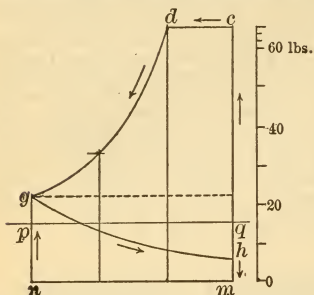

FIG. 166. — WOOLF ENGINE, IDEAL INDICATOR-DIAGRAMS.

The receiver takes the steam exhausted from the first cylinder and supplies it to the second, in which the steam is cut off and then expanded to the end of the stroke. On the assumption that the initial pressure in the second cylinder is equal to the final pressure in the first, and of course equal to the pressure in the receiver, the volume cut off in the second cylinder must be equal to the volume of the first cylinder, for the second cylinder must admit as much steam at each stroke as is discharged from the first cylinder.

In Fig. 167, *cd* is the line of admission and *hg* the exhaust-line for the first cylinder; and *dg* is the expansion-curve and *pq* the atmospheric line.

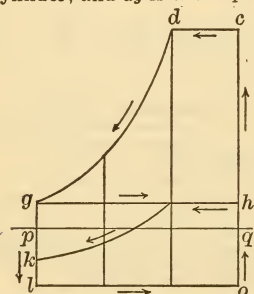

FIG. 167. — RECEIVER-ENGINE, IDEAL INDICATOR-DIAGRAM.

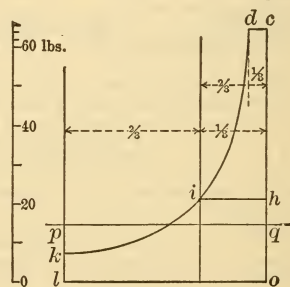

FIG. 168. — RECEIVER ENGINE, IDEAL DIAGRAMS REDUCED AND COMBINED.

In the region below the exhaust-line of the first cylinder, between it and the line of perfect vacuum, *ol*, the diagram of the second cylinder is formed; *hi*, the second line of admission, coincides with the exhaust-line *hg* of the first cylinder, showing in the ideal diagram no intermediate fall of pressure, and *ik* is the expansion-curve. The arrows indicate the order in which the diagrams are formed.

In the action of the receiver-engine, the expansive working of the steam, though clearly divided into two consecutive stages, is, as in the Woolf engine, essentially continuous from the point of cut-off in the first cylinder to the end of the stroke of the second cylinder, where it is delivered to the condenser; and the first and second diagrams may be placed together and combined to form a continuous diagram. For this purpose take the second diagram as the basis of the combined diagram, namely, *hiklo*, Fig. 168. The period of admission, *hi*, is one-third of the stroke, and as the ratios of the cylinders areas 1 to 3, *hi* is also the propor-

tional length of the first diagram as applied to the second. Produce *oh* upwards, and set off *oc* equal to the total height of the first diagram above the vacuum-line; and, upon the shortened base *hi*, and the height *hc*, complete the first diagram with the steam-line *cd* and the expansion line *di*.

It is shown by Clark (*S. E.*, p. 432 *et seq.*) in a series of arithmetical calculations, that the receiver-engine is an elastic system of compound engine, in which considerable latitude is afforded for adapting the pressure in the receiver to the demands of the second cylinder, without considerably diminishing the effective work of the engine. In the Woolf engine, on the contrary, it is of much importance that the intermediate volume of space between the first and second cylinders, which is the cause of an intermediate fall of pressure, should be reduced to the lowest practicable amount.

Supposing that there is no loss of steam in passing through the engine, by cooling and condensation, it is obvious that whatever steam passes through the first cylinder must also find its way through the second cylinder. By varying, therefore, in the receiver-engine, the period of admission in the second cylinder, and thus also the volume of steam admitted for each stroke, the steam will be measured into it at a higher pressure and of a less bulk, or at a lower pressure and of a greater bulk; the pressure and density naturally adjusting themselves to the volume that the steam from the receiver is permitted to occupy in the second cylinder. With a sufficiently restricted admission, the pressure in the receiver may be maintained at the pressure of the steam as exhausted from the first cylinder. On the contrary, with a wider admission, the pressure in the receiver may fall or "drop" to three-fourths or even one-half of the pressure of the exhaust steam from the first cylinder.

(For a more complete discussion of the action of steam in the Woolf and receiver engines, see Clark on the Steam-engine.)

**Combined Diagrams of Compound Engines.** — The only way of making a correct combined diagram from the indicator-diagrams of

the several cylinders in a compound engine is to set off all the diagrams on the same horizontal scale of volumes, adding the clearances to the cylinder capacities proper. When this is attended to, the successive diagrams fall exactly into their right places relatively to one another, and would compare properly with any theoretical expansion-curve, (Prof. A. B. W. Kennedy, *Proc. Inst. M. E.*, Oct., 1886.)

This method of combining diagrams is commonly adopted, but there are objections to its accuracy, since the whole quantity of steam consumed

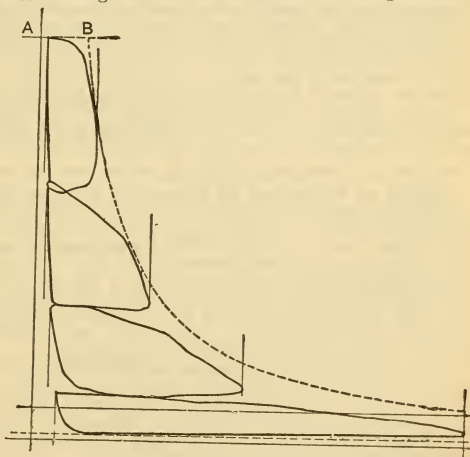

FIG. 169.

in the first cylinder at the end of the stroke is not carried forward to the second, but a part of it is retained in the first cylinder for compression. For a method of combining diagrams in which compression is taken account of, see discussions by Thomas Mudd and others, in *Proc. Inst. M. E.*, Feb., 1887, p. 48. The usual method of combining diagrams is also criticised by Frank H. Ball as inaccurate and misleading (*Am. Mach.*, April 12, 1894; *Trans. A. S. M. E.*, xiv, 1405, and xv, 403).

Figure 169 shows a combined diagram of a quadruple-expansion engine, drawn according to the usual method, that is, the diagrams are first reduced in length to relative scales that correspond with the relative



piston-displacement of the three cylinders. Then the diagrams are placed at such distances from the clearance-line of the proposed combined diagram as to represent correctly the clearance in each cylinder.

**Proportions of Cylinders in Compound Engines.** — Authorities differ as to the proportions by volume of the high and low pressure cylinders  $v$  and  $V$ . Thus Grashof gives  $V \div v = 0.85 \sqrt{r}$ ; Hrabak,  $0.90 \sqrt{r}$ ; Werner,  $\sqrt{r}$ ; and Rankine,  $\sqrt{r^2}$ ,  $r$  being the ratio of expansion. Busley makes the ratio dependent on the boiler-pressure thus:

Lbs. per sq. in. ....	60	90	105	120
$V \div v$ .....	= 3	4	4.5	5

(See Seaton's Manual, p. 95, etc., for analytical method; Sennett, p. 496, etc.; Clark's Steam-engine, p. 445, etc.; Clark's Rules, Tables, Data, p. 849, etc.)

Mr. J. McFarlane Gray states that he finds the mean effective pressure in the compound engine reduced to the low-pressure cylinder to be approximately the square root of 6 times the boiler-pressure.

**Ratio of Cylinder Capacity in Compound Marine Engines.** (Seaton.) — The low-pressure cylinder is the measure of the power of a compound engine, for so long as the initial steam-pressure and rate of expansion are the same, it signifies very little, so far as total power only is concerned, whether the ratio between the low and high pressure cylinders is 3 or 4; but as the power developed should be nearly equally divided between the two cylinders, in order to get a good and steady working engine, there is a necessity for exercising a considerable amount of discretion in fixing on the ratio.

In choosing a particular ratio the objects are to divide the power evenly and to avoid as much as possible "drop" and high initial strain. [Some writers advocate drop in the high-pressure cylinder making it smaller than is the usual practice and making the cylinder ratio as high as 6 or 7.]

If increased economy is to be obtained by increased boiler-pressures the rate of expansion should vary with the initial pressure, so that the pressure at which the steam enters the condenser should remain constant. In this case, with the ratio of cylinders constant, the cut-off in the high-pressure cylinder will vary inversely as the initial pressure.

Let  $R$  be the ratio of the cylinders;  $r$  the rate of expansion;  $p_1$  the initial pressure: then cut-off in high-pressure cylinder =  $R \div r$ ;  $r$  varies with  $p_1$ , so that the terminal pressure  $p_n$  is constant, and consequently  $r = p_1 \div p_n$ ; therefore, cut-off in high-pressure cylinder =  $R \times p_n \div p_1$ .

**Ratios of Cylinders as Found in Marine Practice.** — The rate of expansion may be taken at one-tenth of the boiler-pressure (or about one-twelfth the absolute pressure), to work economically at full speed. Therefore, when the diameter of the low-pressure cylinder does not exceed 100 inches, and the boiler-pressure 70 lbs., the ratio of the low-pressure to the high-pressure cylinder should be 3.5; for a boiler-pressure of 80 lbs., 3.75; for 90 lbs., 4.0; for 100 lbs., 4.5. If these proportions are adhered to, there will be no need of an expansion-valve to either cylinder. If, however, to avoid "drop," the ratio be reduced, an expansion-valve should be fitted to the high-pressure cylinder.

Where economy of steam is not of first importance, but rather a large power, the ratio of cylinder capacities may with advantage be decreased, so that with a boiler-pressure of 100 lbs. it may be 3.75 to 4.

In tandem engines there is no necessity to divide the work equally. The ratio is generally 4, but when the steam-pressure exceeds 90 lbs. absolute 4.5 is better, and for 100 lbs. 5.0.

When the power requires that the l.p. cylinder shall be more than 100 in. diameter, it should be divided in two cylinders. In this case the ratio of the combined capacity of the two l.p. cylinders to that of the h.p. may be 3.0 for 85 lbs. absolute, 3.4 for 95 lbs., 3.7 for 105 lbs., and 4.0 for 115 lbs.

**Receiver Space in Compound Engines** should be from 1 to 1.5 times the capacity of the high-pressure cylinder, when the cranks are at an angle of from  $90^\circ$  to  $120^\circ$ . When the cranks are at  $180^\circ$  or nearly this, the space may be very much reduced. In the case of triple-compound engines, with cranks at  $120^\circ$ , and the intermediate cylinder leading the high-pressure, a very small receiver will do. The pressure in the receiver should never exceed half the boiler-pressure. (Seaton.)

**Formula for Calculating the Expansion and the Work of Steam in Compound Engines.**

(Condensed from Clark on the "Steam-engine.")

- $a$  = area of the first cylinder in square inches;
- $a'$  = area of the second cylinder in square inches;
- $r$  = ratio of the capacity of the second cylinder to that of the first;
- $L$  = length of stroke in feet, supposed to be the same for both cylinders;
- $l$  = period of admission to the first cylinder in feet, excluding clearance;
- $c$  = clearance at each end of the cylinders, in feet;
- $L'$  = length of the stroke plus the clearance, in feet;
- $l'$  = period of admission plus the clearance, in feet;
- $s$  = length of a given part of the stroke of the second cylinder, in feet;
- $P$  = total initial pressure in the first cylinder, in lbs. per square inch, supposed to be uniform during admission;
- $P'$  = total pressure at the end of the given part of the stroke  $s$ ;
- $p$  = average total pressure for the whole stroke;
- $R$  = nominal ratio of expansion in the first cylinder, or  $L \div l$ ;
- $R'$  = actual ratio of expansion in the first cylinder, or  $L' \div l'$ ;
- $R''$  = actual combined ratio of expansion, in the first and second cylinders together;
- $n$  = ratio of the final pressure in the first cylinder to any intermediate fall of pressure between the first and second cylinders;
- $N$  = ratio of the volume of the intermediate space in the Woolf engine, reckoned up to, and including the clearance of, the second piston, to the capacity of the first cylinder plus its clearance. The value of  $N$  is correctly expressed by the actual ratio of the volumes as stated, on the assumption that the intermediate space is a vacuum when it receives the exhaust-steam from the first cylinder. In point of fact, there is a residuum of unexhausted steam in the intermediate space, at low pressure, and the value of  $N$  is thereby practically reduced below the ratio here stated.

$$N = \frac{n}{n-1} - 1.$$

$w$  = whole net work in one stroke, in foot-pounds.

Ratio of expansion in the second cylinder:

In the Woolf engine,  $\frac{\left(r \frac{L}{L'}\right) + N}{1 + N}$ ;

In the receiver-engine,  $\frac{(n-1)r}{n}$ .

Total actual ratio of expansion = product of the ratios of the three consecutive expansions, in the first cylinder, in the intermediate space, and in the second cylinder,

In the Woolf engine,  $R' \left(r \frac{L}{L'} + N\right)$ ;

In the receiver-engine,  $r \frac{L'}{l'}$ , or  $rR'$ .

Combined ratio of expansion behind the pistons =  $\frac{n-1}{n} rR' = R''$ .

Work done in the two cylinders for one stroke, with a given cut-off and a given combined actual ratio of expansion:

Woolf engine,  $w = aP [l'(1 + \text{hyp log } R'') - c]$ ;

Receiver engine,  $w = aP \left[ l' (1 + \text{hyp log } R'') - c \left( 1 + \frac{r-1}{R'} \right) \right]$ .

when there is no intermediate fall of pressure.

When there is an intermediate fall, when the pressure falls to  $\frac{3}{4}$ ,  $\frac{2}{3}$ ,  $\frac{1}{2}$  of the final pressure in the 1st cylinder, the reduction of work is 0.2%, 1.0%, 4.6% of that when there is no fall.

Total work in the two cylinders of a receiver-engine, for one stroke for any intermediate fall of pressure,

$$w = aP \left[ v' \left( \frac{n+1}{n} + \text{hyp log } R'' \right) - c \left( 1 + \frac{(n-1)(r-1)}{nR'} \right) \right].$$

EXAMPLE. — Let  $a = 1$  sq. in.,  $P = 63$  lbs.,  $v' = 2.42$  ft.,  $n = 4$ ,  $R'' = 5.969$ ,  $c = 0.42$  ft.,  $r = 3$ ,  $R' = 2.653$ :

$$w = 1 \times 63 \left[ 2.42 \left( \frac{5}{4} \text{ hyp log } 5.969 \right) - .42 \left( 1 + \frac{3 \times 2}{4 \times 2.653} \right) \right] = 421.55 \text{ ft.-lbs.}$$

**Calculation of Diameters of Cylinders** of a compound condensing engine of 2000 H.P. at a speed of 700 feet per minute, with 100 lbs. boiler-pressure.

100 lbs. gauge-pressure = 115 absolute, less drop of 5 lbs. between boiler and cylinder = 110 lbs. initial absolute pressure. Assuming terminal pressure in l.p. cylinder = 6 lbs., the total expansion of steam in both cylinders =  $110 \div 6 = 18.33$ . Hyp log 18.33 = 2.909. Back pressure in l.p. cylinder, 3 lbs. absolute.

The following formulæ are used in the calculation of each cylinder:  
 H.P.  $\times$  33,000

(1) Area of cylinder =  $\frac{\text{M.E.P.} \times \text{piston-speed}}{\text{H.P.} \times 33,000}$

(2) Mean effective pressure = mean total pressure - back pressure.

(3) Mean total pressure = terminal pressure  $\times$  (1 + hyp log  $R$ ).

(4) Absolute initial pressure = absolute terminal pressure  $\times$  ratio of expansion.

First calculate the area of the low-pressure cylinder as if all the work were done in that cylinder.

From (3), mean total pressure =  $6 \times (1 + \text{hyp log } 18.33) = 23.454$  lbs.

From (2), mean effective pressure =  $23.454 - 3 = 20.454$  lbs.

From (1), area of cylinder =  $\frac{2000 \times 33,000}{20.454 \times 700} = 4610$  sq. ins. = 76.6 ins. diam.

If half the work, or 1000 H.P., is done in the l.p. cylinder the M.E.P. will be half that found above, or 10.227 lbs., and the mean total pressure  $10.227 + 3 = 13.227$  lbs.

From (3),  $1 + \text{hyp log } R = 13.227 \div 6 = 2.2045$ .

Hyp log  $R = 1.2045$ , whence  $R$  in l.p. cyl. = 3.335.

From (4),  $3.335 \times 6 = 20.01$  lbs. initial pressure in l.p. cyl. and terminal pressure in h.p. cyl., assuming no drop between cylinders.

$110 \div 20.01 = 5.497$ ,  $R$  in h.p. cyl.

From (3), mean total pres. in h.p. cyl. =  $20.01 \times (1 + \text{hyp log } 5.497) = 54.11$ .

From (2),  $54.11 - 20.01 = 34.10$ , M.E.P. in h.p. cyl.

From (1), area of h.p. cyl. =  $\frac{1000 \times 33,000}{34.1 \times 700} = 1382$  sq. ins. = 42 ins. diam.

Cylinder ratio =  $4610 \div 1382 = 3.336$ .

The area of the h.p. cylinder may be found more directly by dividing the area of the l.p. cyl. by the ratio of expansion in that cylinder.  $4610 \div 3.335 = 1382$  sq. ins.

In the above calculation no account is taken of clearance, of compression, of drop between cylinders, nor of area of piston-rods. It also assumes that the diagram in each cylinder is the full theoretical diagram, with a horizontal steam-line and a hyperbolic expansion line, with no allowance for rounding of the corners. To make allowance for these, the mean effective pressure in each cylinder must be multiplied by a diagram factor, or the ratio of the area of an actual diagram of the class of engine considered, with the given initial and terminal pressures, to the area of the theoretical diagram. Such diagram factors will range from 0.6 to 0.94, as in the table on p. 962.

**Best Ratios of Cylinders.** — The question what is the best ratio of areas of the two cylinders of a compound engine is still (1901) a disputed one, but there appears to be an increasing tendency in favor of large



ratios, even as great as 7 or 8 to 1, with considerable terminal drop in the high-pressure cylinder. A discussion of the subject, together with a description of a new method of drawing theoretical diagrams of multiple-expansion engines, taking into consideration drop, clearance, and compression will be found in a paper by Bert C. Ball, in *Trans. A. S. M. E.*, **xxi**, 1002.

### TRIPLE-EXPANSION ENGINES.

**Proportions of Cylinders.** — H. H. Suplee, *Mechanics*, Nov., 1887, gives the following method of proportioning cylinders of triple-expansion engines:

As in the case of compound engines the diameter of the low-pressure cylinder is first determined, being made large enough to furnish the entire power required at the mean pressure due to the initial pressure and expansion ratio given; and then this cylinder is given only pressure enough to perform one-third of the work, and the other cylinders are proportioned so as to divide the other two-thirds between them.

Let us suppose that an initial pressure of 150 lbs. is used and that 900 H.P. is to be developed at a piston-speed of 800 ft. per min., and that an expansion ratio of 16 is to be reached with an absolute back-pressure of 2 lbs.

The theoretical M.E.P. with an absolute initial pressure of  $150 + 14.7 = 164.7$  lbs. initial at 16 expansions is

$$\frac{P(1 + \text{hyp log } 16)}{16} = 164.7 \times \frac{3.7726}{16} = 38.83,$$

less 2 lbs. back pressure,  $= 38.83 - 2 = 36.83$ .

In practice only about 0.7 of this pressure is actually attained, so that  $36.83 \times 0.7 = 25.781$  lbs. is the M.E.P. upon which the engine is to be proportioned.

To obtain 900 H.P. we must have  $33,000 \times 900 = 29,700,000$  foot-pounds, and this divided by the mean pressure (25.78) and by the speed in feet (800) will give 1440 sq. in. as the area of the l.p. cylinder, about equivalent to 43 in. diam.

Now as one-third of the work is to be done in the l.p. cylinder, the M.E.P. in it will be  $25.78 \div 3 = 8.59$  lbs.

The cut-off in the high-pressure cylinder is generally arranged to cut off at 0.6 of the stroke, and so the ratio of the h.p. to the l.p. cylinder is equal to  $16 \times 0.6 = 9.6$ , and the h.p. cylinder will be  $1440 \div 9.6 = 150$  sq. in. area, or about 14 in. diameter, and the M.E.P. in the h.p. cylinder is equal to  $9.6 \times 8.59 = 82.46$  lbs.

If the intermediate cylinder is made a mean size between the other two, its size would be determined by dividing the area of the l.p. cylinder by the square root of the ratio between the low and the high; but in practice this is found to give a result too large to equalize the stresses, so that instead the area of the int. cylinder is found by dividing the area of the l.p. piston by 1.1 times the square root of the ratio of l.p. to h.p. cylinder, which in this case is  $1440 \div (1.1 \sqrt{9.6}) = 422.5$  sq. in., or a little more than 23 in. diam.

The choice of expansion ratio is governed by the initial pressure, and is generally chosen so that the terminal pressure in the l.p. cylinder shall be about 10 lbs. absolute.

**Formulae for Proportioning Cylinder Areas of Triple-Expansion Engines.** — The following formulae are based on the method of first finding the cylinder areas that would be required if an ideal hyperbolic diagram were obtainable from each cylinder, with no clearance, compression, wire-drawing, drop by free expansion in receivers, or loss by cylinder condensation, assuming equal work to be done in each cylinder, and then dividing the areas thus found by a suitable diagram factor, such as those given on page 962, expressing the ratio which the area of an actual diagram, obtained in practice from an engine of the type under consideration, bears to the ideal or theoretical diagram. It will vary in different classes of engine and in different cylinders of the same engine, usual values ranging from 0.6 to 0.9. When any one of the three stages of expansion takes place in two cylinders, the combined area of these cylinders equals the area found by the formulae.

NOTATION.

- $p_1$  = initial pressure in the high-pressure cylinder.
- $p_t$  = terminal pressure in the low-pressure cylinder.
- $p_b$  = back pressure in the low-pressure cylinder.
- $p_2$  = term. press. in h.p. cyl. and initial press. in intermediate cyl.
- $p_3$  = term. press. in int. cyl. and initial press. in l.p. cyl.
- $R_1, R_2, R_3$ , ratio of exp. in h.p. int. and l.p. cyls.
- $R$  = total ratio of exp. =  $R_1 \times R_2 \times R_3$ .
- $P$  = M.E.P. of the combined ideal diagram, referred to the l.p. cyl.
- $P_1, P_2, P_3$  = M.E.P. in the h.p., int., and l.p. cyls.
- $HP$  = horse-power of the engine =  $PLA_3N \div 33,000$ .
- $L$  = length of stroke in feet;  $N$  = number of single strokes per min.
- $A_1, A_2, A_3$ , areas (sq. ins.) of h.p. int. and l.p. cyls. (ideal).
- $W$  = work done in one cylinder per foot of stroke.
- $r_2$  = ratio of  $A_2$  to  $A_1$ ;  $r_3$  = ratio of  $A_3$  to  $A_1$ .
- $F_1, F_2, F_3$ , diagram factors of h.p. int. and l.p. cyl.
- $a_1, a_2, a_3$ , areas (actual) of h.p. int. and l.p. cyl.

Formulae.

- (1)  $R = p_1 \div p_t$ .
- (2)  $P = p_t (1 + \text{hyp log } R) - p_b$ .
- (3)  $P_3 = \frac{1}{3} P$ .
- (4)  $\text{Hyp log } R_3 = (P_3 - p_t + p_b) \div p_t$ .
- (5)  $R_1 R_2 = R \div R_3$ ;  $R_1 = R_2 = \sqrt{R_1 R_2}$ .
- (6)  $p_3 = p_t \times R_3$ .
- (7)  $p_2 = p_3 \times R_2$ .
- (8)  $p_1 = p_2 \times R_1$ .
- (9)  $P_2 = p_3 (\text{hyp log } R_2) = P_3 R_3$ .
- (10)  $P_1 = p_2 (\text{hyp log } R_1) = P_2 R_2$ .
- (11)  $W = 11,000 HP \div LN$ .
- (12)  $A_1 = W \div P_1$ ;  $A_2 = W \div P_2$ ;  $A_3 = W \div P_3$ .
- (13)  $r_2 = A_2 \div A_1 = P_1 \div P_2 = R_1$  or  $R_2$ ;  $r_3 = A_3 \div A_1 = P_1 \div P_3$ .
- (14)  $a_1 = A_1 \div F_1$ ;  $a_2 = A_2 \div F_2$ ;  $a_3 = A_3 \div F_3$ .

From these formulæ the figures in the following tables have been calculated:

THEORETICAL MEAN EFFECTIVE PRESSURES, CYLINDER RATIOS, ETC., OF TRIPLE-EXPANSION ENGINES.

Back pressure, 3 lbs. Terminal pressure, 8 lbs. (absolute).

$p_1$ .	$R$ .	$P$ .	$P_3$ .	$R_3$ .	$R_1, R_2$ , or $r_2$ .	$p_3$ .	$p_2$ .	$P_2$ .	$P_1$ .	$r_3$ .
120	15	26.66	8.89	1.626	3.037	13.01	39.51	14.45	43.89	4.939
140	17.5	27.90	9.30	1.712	3.197	13.70	43.79	15.92	50.89	5.472
160	20	28.97	9.66	1.790	3.343	14.32	47.86	17.29	57.76	5.980
180	22.5	29.91	9.97	1.861	3.477	14.89	51.77	18.55	64.52	6.471
200	25	30.75	10.25	1.928	3.601	15.42	55.54	19.76	71.16	6.942
220	27.5	31.51	10.50	1.990	3.718	15.91	59.16	20.90	77.69	7.397
240	30	32.21	10.74	2.049	3.826	16.39	62.72	22.00	84.16	7.839

THEORETICAL MEAN EFFECTIVE PRESSURES, CYLINDER RATIOS, ETC., OF TRIPLE-EXPANSION ENGINES.

Back pressure, 3 lbs. Terminal pressure, 10 lbs. (absolute).

$p_1$ .	$R$ .	$P$ .	$P_3$ .	$R_3$ .	$R_1, R_2$ , or $r_2$ .	$p_3$ .	$p_2$ .	$P_2$ .	$P_1$ .	$r_3$ .
120	12	31.85	10.62	1.436	2.890	14.36	41.50	15.24	44.04	4.148
140	14	33.39	11.13	1.511	3.044	15.11	45.99	16.82	51.20	4.600
160	16	34.73	11.58	1.580	3.182	15.80	50.28	18.29	58.20	5.027
180	18	35.90	11.97	1.643	3.310	16.43	54.38	19.66	65.09	5.439
200	20	36.96	12.32	1.702	3.428	17.02	58.34	20.97	71.88	5.834
220	22	37.91	12.64	1.757	3.538	17.57	62.15	22.20	78.54	6.215
240	24	38.78	12.93	1.809	3.642	18.09	65.88	23.38	85.15	6.587

Given the required H.P. of an engine, its speed and length of stroke,

and the assumed diagram factors  $F_1$ ,  $F_2$ ,  $F_3$  for the three cylinders, the areas of the cylinders may be found by using formulæ (11), (12), and (14), and the values of  $P_1$ ,  $P_2$ , and  $P_3$  in the above table.

**A Common Rule for Proportioning the Cylinders of multiple-expansion engines is:** for two-cylinder compound engines, the cylinder ratio is the square root of the number of expansions, and for triple-expansion engines the ratios of the high to the intermediate and of the intermediate to the low are each equal to the cube root of the number of expansions, the ratio of the high to the low being the product of the two ratios, that is, the square of the cube root of the number of expansions. Applying this rule to the pressures above given, assuming a terminal pressure (absolute) of 10 lbs. and 8 lbs. respectively, we have, for triple-expansion engines:

Boiler-pressure (Absolute).	Terminal Pressure, 10 lbs.		Terminal Pressure, 8 lbs.	
	No. of Expansions.	Cylinder Ratios, areas.	No. of Expansions.	Cylinder Ratios, areas.
130	13	1 to 2.35 to 5.53	16 $\frac{1}{4}$	1 to 2.53 to 6.42
140	14	1 to 2.41 to 5.81	17 $\frac{1}{2}$	1 to 2.60 to 6.74
150	15	1 to 2.47 to 6.08	18 $\frac{3}{4}$	1 to 2.66 to 7.06
160	16	1 to 2.52 to 6.35	20	1 to 2.71 to 7.37

The ratio of the diameters is the square root of the ratios of the areas, and the ratio of the diameters of the first and third cylinders is the same as the ratio of the areas of first and second.

Seaton, in his *Marine Engineering*, says: When the pressure of steam employed exceeds 115 lbs. absolute, it is advisable to employ three cylinders, through each of which the steam expands in turn. The ratio of the low-pressure to high-pressure cylinder in this system should be 5, when the steam-pressure is 125 lbs. absolute; when 135 lbs., 5.4; when 145 lbs., 5.8; when 155 lbs., 6.2; when 165 lbs., 6.6. The ratio of low-pressure to intermediate cylinder should be about one-half that between low-pressure and high-pressure, as given above. That is, if the ratio of l.p. to h.p. is 6, that of l.p. to int. should be about 3, and consequently that of int. to h.p. about 2. In practice the ratio of int. to h.p. is nearly 2.25, so that the diameter of the int. cylinder is 1.5 that of the h.p. The introduction of the triple-compound engine has admitted of ships being propelled at higher rates of speed than formerly obtained without exceeding the consumption of fuel of similar ships fitted with ordinary compound engines; in such cases the higher power to obtain the speed has been developed by decreasing the rate of expansion, the low-pressure cylinder being only 6 times the capacity of the high-pressure, with a working pressure of 170 lbs. absolute. It is now a very general practice to make the diameter of the low-pressure cylinder equal to the sum of the diameters of the h.p. and int. cylinders; hence,

Diameter of int. cylinder = 1.5 diameter of h.p. cylinder;

Diameter of l.p. cylinder = 2.5 diameter of h.p. cylinder.

In this case the ratio of l.p. to h.p. is 6.25; the ratio of int. to h.p. is 2.25; and ratio of l.p. to int. is 2.78.

**Ratios of Cylinders for Different Classes of Engines.** (*Proc. Inst. M. E.*, Feb., 1887, p. 36.)—As to the best ratios for the cylinders in a triple engine there seems to be great difference of opinion. Considerable latitude, however, is due to the requirements of the case, inasmuch as it would not be expected that the same ratio would be suitable for an economical land engine, where the space occupied and the weight were of minor importance, as in a war-ship, where the conditions were reversed. In the land engine, for example, a theoretical terminal pressure of about 7 lbs. above absolute vacuum would probably be aimed at, which would give a ratio of capacity of high pressure to low pressure of 1 to 8 $\frac{1}{2}$  or 1 to 9; whilst in a war-ship a terminal pressure would be required of 12 to 13 lbs. which would need a ratio of capacity of 1 to 5; yet in both these instances the cylinders were correctly proportioned and suitable to the requirements of the case. It is obviously unwise, therefore, to introduce any hard-and-fast rule.

**Types of Three-stage Expansion Engines.**—1. Three cranks at



120 deg. 2. Two cranks with 1st and 2d cylinders tandem. 3. Two cranks with 1st and 3d cylinders tandem. The most common type is the first, with cylinders arranged in the sequence high, intermediate, low.

**Sequence of Cranks.** — Mr. Wyllie (*Proc. Inst. M. E.*, 1887) favors the sequence high, low, intermediate, while Mr. Mudd favors high, intermediate, low. The former sequence, high, low, intermediate, gave an approximately horizontal exhaust-line, and thus minimizes the range of temperature and the initial load; the latter sequence high, intermediate, low, increased the range and also the load.

Mr. Morrison, in discussing the question of sequence of cranks, presented a diagram showing that with the cranks arranged in the sequence high, low, intermediate, the mean compression into the receiver was  $19\frac{1}{2}$  per cent of the stroke; with the sequence high, intermediate, low, it was 57 per cent.

In the former case the compression was just what was required to keep the receiver-pressure practically uniform; in the latter case the compression caused a variation in the receiver-pressure to the extent sometimes of  $22\frac{1}{2}$  lbs.

**Velocity of Steam through Passages in Compound Engines.** (*Proc. Inst. M. E.*, Feb., 1887.) — In the *SS. Para*, taking the area of the cylinder multiplied by the piston-speed in feet per second and dividing by the area of the port the velocity of the initial steam through the high-pressure cylinder port would be about 100 feet per second; the exhaust would be about 90. In the intermediate cylinder the initial steam had a velocity of about 180, and the exhaust of 120. In the low-pressure cylinder, the initial steam entered through the port with a velocity of 250, and in the exhaust-port the velocity was about 140 feet per second.

**A Double-tandem Triple-expansion Engine**, built by Watts, Campbell & Co., Newark, N. J., is described in *Am. Mach.*, April 26, 1894. It is two three-cylinder tandem engines coupled to one shaft, cranks at  $90^\circ$ , cylinders 21, 32 and 48 by 60 in. stroke, 65 revolutions per minute, rated H.P. 2000; fly-wheel 28 ft. diameter, 12 ft. face, weight 174,000 lbs.; main shaft 22 in. diameter at the swell; main journals  $19 \times 38$  in.; crank-pins  $9\frac{1}{2} \times 10$  in.; distance between center lines of two engines 24 ft.  $7\frac{1}{2}$  in.; Corliss valves, with separate eccentrics for the exhaust-valves of the l.p. cylinder.

## QUADRUPLE-EXPANSION ENGINES.

H. H. Suplee (*Trans. A. S. M. E.*, x, 583) states that a study of 14 different quadruple-expansion engines, nearly all intended to be operated at a pressure of 180 lbs. per sq. in., gave average cylinder ratios of 1 to 2, to 3.78, to 7.70, or nearly in the proportions 1, 2, 4, 8.

If we take the ratio of areas of any two adjoining cylinders as the fourth root of the number of expansions, the ratio of the 1st to the 4th will be the cube of the fourth root. On this basis the ratios of areas for different pressures and rates of expansion will be as follows:

Gauge-pressures.	Absolute Pressures.	Terminal Pressures.	Ratio of Expansion.	Ratios of Areas of Cylinders.
160	175	{ 12	14.6	1 : 1.95 : 3.81 : 7.43
		{ 10	17.5	1 : 2.05 : 4.18 : 8.55
		{ 8	21.9	1 : 2.16 : 4.68 : 10.12
180	195	{ 12	16.2	1 : 2.01 : 4.02 : 8.07
		{ 10	19.5	1 : 2.10 : 4.42 : 9.28
		{ 8	24.4	1 : 2.22 : 4.94 : 10.98
200	215	{ 12	17.9	1 : 2.06 : 4.23 : 8.70
		{ 10	21.5	1 : 2.15 : 4.64 : 9.98
		{ 8	26.9	1 : 2.28 : 5.19 : 11.81
220	235	{ 12	19.6	1 : 2.10 : 4.43 : 9.31
		{ 10	23.5	1 : 2.20 : 4.85 : 10.67
		{ 8	29.4	1 : 2.33 : 5.42 : 12.62

Seaton says: When the pressure of steam employed exceeds 190 lbs. absolute, four cylinders should be employed, with the steam expanding

through each successively; and the ratio of l.p. to h.p. should be at least 1.5, and if economy of fuel is of prime consideration it should be 8; then the ratio of first intermediate to h.p. should be 1.8, that of second intermediate to first int. 2, and that of l.p. to second int. 2.2.

In a paper read before the North East Coast Institution of Engineers and Shipbuilders, 1890, William Russell Cummins advocates the use of a four-cylinder engine with four cranks as being more suitable for high speeds than the three-cylinder three-crank engine. The cylinder ratios, he claims, should be designed so as to obtain equal initial loads in each cylinder. The ratios determined for the triple engine are 1, 2.04, 6.54, and for the quadruple, 1, 2.08, 4.46, 10.47. He advocates long stroke, high piston-speed, 100 revolutions per minute, and 250 lbs. boiler-pressure, unjacketed cylinders, and separate steam and exhaust valves.

**ECONOMIC PERFORMANCE OF STEAM-ENGINES.**

**Economy of Expansive Working under Various Conditions, Single Cylinder.**

(Abridged from Clark on the Steam Engine.)

1. SINGLE CYLINDERS WITH SUPERHEATED STEAM, NON-CONDENSING.— Inside cylinder locomotive, cylinders and steam-pipes enveloped by the hot gases in the smoke-box. Net boiler pressure 100 lbs.; net maximum pressure in cylinders 80 lbs. per sq. in.

Cut-off, per cent . . . . .	20	25	30	35	40	50	60	70	80
Actual ratio of expansion . . . . .	3.91	3.31	2.87	2.53	2.26	1.86	1.59	1.39	1.23
Water per I.H.P. per hour, lbs. . . . .	18.5	19.4	20	21.2	22.2	24.5	27	30	33

2. SINGLE CYLINDERS WITH SUPERHEATED STEAM, CONDENSING.— The best results obtained by Hirn, with a cylinder 23<sup>3</sup>/<sub>4</sub> × 67 in. and steam superheated 150° F., expansion ratio 3<sup>3</sup>/<sub>4</sub> to 4<sup>1</sup>/<sub>2</sub>, total maximum pressure in cylinder 63 to 69 lbs., were 15.63 and 15.69 lbs. of water per I.H.P. per hour.

3. SINGLE CYLINDERS, NOT STEAM-JACKETED, CONDENSING.— The best result is from a Corliss-Wheelock engine 18 × 48 in.; cut-off, 12.5%; actual expansion ratio, 6.95; maximum absolute pressure in cylinder, 104 lbs.; steam per I.H.P. hour, 19.58 lbs. Other engines, with lower steam pressures, gave a steam consumption as high as 26.7 lbs.

**Feed-water Consumption of Different Types of Engines.**— The following tables are taken from the circular of the *Tabor Indicator* (Ashcroft Mfg. Co., 1889). In the first of the two columns under Feed-water required, in the tables for simple engines, the figures are obtained by computation from nearly perfect indicator diagrams, with allowance for cylinder condensation according to the table on page 936, but without allowance for leakage, with back-pressure in the non-condensing table taken at 16 lbs. above zero, and in the condensing table at 3 lbs. above zero. The compression curve is supposed to be hyperbolic, and commences at 0.91 of the return-stroke, with a clearance of 3% of the piston-displacement.

Table No. 2 gives the feed-water consumption for jacketed compound-condensing engines of the best class. The water condensed in the jackets is included in the quantities given. The ratio of areas of the two cylinders is as 1 to 4 for 120 lbs. pressure; the clearance of each cylinder is 3% and the cut-off in the two cylinders occurs at the same point of stroke. The initial pressure in the l.p. cylinder is 1 lb. per sq. in. below the back-pressure of the h.p. cylinder. The average back-pressure of the whole stroke in the l.p. cylinder is 4.5 lbs. for 10% cut-off; 4.75 lbs. for 20% cut-off; and 5 lbs. for 30% cut-off. The steam accounted for by the indicator at cut-off in the h.p. cylinder (allowing a small amount for leakage) is 0.74 at 10% cut-off, 0.78 at 20%, and 0.82 at 30% cut-off. The loss by condensation between the cylinders is such that the steam accounted for at cut-off in the l.p. cylinder, expressed in proportion of that shown at release in the h.p. cylinder, is 0.85 at 10% cut-off, 0.87 at 20% cut-off, and 0.89 at 30% cut-off.

TABLE No. 1.  
FEED-WATER CONSUMPTION, SIMPLE ENGINES.

NON-CONDENSING ENGINES.					CONDENSING ENGINES.				
Per cent Cut-off.	Initial Pressure above Atmosphere, lbs.	Mean Effective Pressure, lbs.	Feed-water Required per I.H.P. per Hour.		Per cent Cut-off.	Initial Pressure above Atmosphere, lbs.	Mean effective Pressure, lbs.	Feed-water Required per I.H.P. per Hour.	
			Corresponding to Diameters with no Leakage, lbs.	Corresponding to Actual Results Attained in Practice, assuming Slight Leakage.				Corresponding to Diameters with no Leakage, lbs.	Corresponding to Actual Results Attained in Practice, assuming Slight Leakage.
10	80	16.07	27.61	29.88	10	80	29.72	17.30	18.89
	90	19.76	25.43	27.43		90	33.41	17.15	18.70
	100	23.45	23.90	25.73		100	37.10	17.02	18.56
20	80	32.02	21.04	25.68	15	80	38.28	17.60	19.09
	90	37.47	23.00	24.57		90	42.92	17.45	18.91
	100	42.92	22.25	25.77		100	47.56	17.32	18.74
30	80	43.97	24.71	26.29	20	80	45.63	18.27	19.69
	90	50.73	23.91	25.38		90	51.08	18.14	19.51
	100	57.49	23.27	24.68		100	56.53	18.02	19.36
40	80	53.25	25.76	27.17	30	80	57.57	19.91	21.25
	90	61.01	25.03	26.35		90	64.32	19.78	21.06
	100	68.76	24.47	25.73		100	71.08	19.67	20.93
50	80	60.44	26.99	28.38	40	80	66.85	21.36	22.56
	90	68.96	26.32	27.62		90	74.60	21.24	22.41
	100	77.48	25.78	26.99		100	82.36	21.13	22.24

TABLE No. 2  
FEED-WATER CONSUMPTION FOR COMPOUND CONDENSING ENGINES.

Cut-off per cent.	Initial Pressure above Atmosphere.		Mean Effective Press.		Feed-water Required per I.H.P. per Hour, lb.
	h.p.Cyl., lb.	l.p.Cyl., lb.	h.p.Cyl., lb.	l.p.Cyl., lb.	
10	80	4.0	11.67	2.65	16.92
	100	7.3	15.33	3.87	15.00
	120	11.0	18.54	5.23	13.86
20	80	4.3	26.73	5.48	14.60
	100	8.1	33.13	7.56	13.67
	120	12.1	39.29	9.74	13.09
30	80	4.6	37.61	7.48	14.99
	100	8.5	46.41	10.10	14.21
	120	11.7	56.00	12.26	13.87

**Sizes and Calculated Performances of Vertical High-speed Engines.** — The following tables are taken from an old circular, describing the engines made by the Lake Erie Engineering Works, Buffalo, N. Y. The engines are fair representatives of the type largely used for driving dynamos directly without belts. The tables were calculated by E. F. Williams, designer of the engines. They are here somewhat abridged to save space.



Simple Engines — Non-condensing.

Diam. of Cylinder, ins.	Stroke, ins.	Revs. per Minute.	H.P. when cutting off at 1/5 stroke.			H.P. when cutting off at 1/4 stroke.			H.P. when cutting off at 1/3 stroke.			Dimensions of Wheels. dia. face		Steam-pipe, ins.	Exhaust-pipe.	
			70 lbs.	80 lbs.	90 lbs.	70 lbs.	80 lbs.	90 lbs.	70 lbs.	80 lbs.	90 lbs.	Ft.	In.			
7 1/2	10	370	20	25	30	26	31	36	32	37	43	4	4	2 1/2	3	
8 1/2	12	318	27	32	39	34	41	47	41	48	56	4 1/2	5	2 3/4	3 1/2	
10 1/2	14	277	41	49	60	52	62	71	63	74	85	5'9"	6 1/2	3 1/2	4	
12	16	246	53	64	77	67	81	93	82	96	111	6'8"	9	4	4 1/2	
13 1/2	18	222	66	80	96	84	100	116	102	120	138	7 1/2	11	4	5	
16	20	181	95	115	138	120	144	166	146	172	198	8'4"	15	4 1/2	6	
18	24	158	119	144	173	151	181	208	183	215	248	10	19	5	7	
22	28	138	179	216	261	227	272	313	276	324	373	11'8"	28	6	8	
24 1/2	32	120	221	267	322	281	336	386	340	400	460	13'4"	34	7	9	
27	34	112	269	325	392	342	409	470	414	487	560	14'2"	41	8	10	
M.E.P., lbs. . . .			24	29	35	30.5	36.5	42	37	43.5	50	Note. — The nominal-power rating of the engines is at 80 lbs. gauge pressure, steam cut-off at 1/4 stroke.				
Ratio of exp. . . .			5			4			3							
Term'l press. (about), lbs. .			17.9	20	22.3	22.4	25	27.6	29.8	33.3	36.8					
Cyl. cond'n, %.			26	26	26	24	24	24	21	21	21					
Steam per I.H.P. hour, lbs. . . . .			32.9	30	27.4	31.2	29.0	27.9	32	31.4	30					

Compound Engines — Non-condensing — High-pressure Cylinder and Receiver Jacketed.

Diam. Cylinder, inches.			Stroke, inches.	Revolutions per Minute.	H.P., cutting off at 1/4 Stroke in h.p. Cylinder.				H.P., cutting off at 1/3 Stroke in h.p. Cylinder.				H.P., cutting off at 1/2 Stroke in h.p. Cylinder.			
H.P.	H.P.	L.P.			Cyls. 3 1/3 : 1.		Cyls. 4 1/2 : 1.		Cyls. 3 1/3 : 1.		Cyls. 4 1/2 : 1.		Cyls. 3 1/3 : 1.		Cyls. 4 1/2 : 1.	
			80 lbs.	90 lbs.	130 lbs.	150 lbs.	80 lbs.	90 lbs.	130 lbs.	150 lbs.	80 lbs.	90 lbs.	130 lbs.	150 lbs.		
5 3/4	6 1/2	12	10	370	7	15	19	32	23	31	35	46	44	55	64	79
6 3/8	7 1/2	13 1/2	12	318	9	19	24	40	29	39	45	59	56	70	81	101
7 3/4	9	16 1/2	14	277	14	28	36	60	43	58	67	87	83	104	121	159
9	10 1/2	19	16	246	18	37	47	78	57	76	87	114	109	136	158	196
10 1/2	12	22 1/2	18	222	26	53	68	112	81	109	125	164	156	195	226	281
12	13 1/2	25	20	185	32	65	84	139	100	135	154	202	192	241	279	346
13 1/2	15 1/2	28 1/2	24	158	43	88	112	186	135	181	206	271	258	323	374	464
16	18 1/2	33 1/2	28	138	57	118	151	249	180	242	277	363	346	433	502	623
18	20 1/2	38	32	120	74	152	194	321	232	312	357	468	446	558	647	803
20	22 1/2	43	34	112	94	194	249	412	297	400	457	601	572	715	829	1030
24 1/2	28 1/2	52	42	93	138	285	365	603	436	587	670	880	838	1048	1215	1508
28 1/2	33	60	48	80	180	374	477	789	570	767	877	1151	1096	1370	1589	1973
Mean eff. pressure, lbs..					3.3	6.8	8.7	14.4	10.4	14.0	16	21	20	25	29	36
Ratio of expansion . . . .					13 1/2		18 1/4		10 1/4		13 3/4		6 3/4		9 1/4	
Cyl. condensation, % . .					14	14	16	16	12	12	13	13	10	10	11	11
Ter. pres. (abt.), lbs. . .					7.3	7.7	7.9	9	9.2	10.4	10.5	12	14	15.5	14.6	17.8
Loss from expanding below atmosphere, %					34	15	17	3	5	0	0	0	0	0	0	0
St. per I.H.P. hour, lbs.					55	42	47	29	33.3	27.7	28.7	25.4	30	26.2	21	20

## Compound Engines — Condensing — Steam-jacketed.

Diam. Cylinder, inches.			Stroke, inches.	Revolutions per Minute.	H.P. when cutting off at 1/4 Stroke in h.p. Cylinder.				H.P. when cutting off at 1/3 Stroke in h.p. Cylinder.				H.P. when cutting off at 1/2 Stroke in h.p. Cylinder.			
					Ratio, 3 1/3 : 1.		Ratio, 4 : 1.		Ratio, 3 1/3 : 1.		Ratio, 4 : 1.		Ratio, 3 1/3 : 1.		Ratio, 4 : 1.	
H.P.	H.P.	L.P.			80 lbs.	110 lbs.	115 lbs.	125 lbs.	80 lbs.	110 lbs.	115 lbs.	125 lbs.	80 lbs.	110 lbs.	115 lbs.	125 lbs.
6	6 1/2	12	10	370	44	59	53	62	55	70	68	75	70	97	95	106
6 1/2	7 1/2	13 1/2	12	318	56	76	67	76	70	90	87	95	90	123	120	134
8 1/4	9	16 1/2	14	277	83	112	100	111	104	133	129	141	133	183	179	200
9 1/2	10 1/2	19	16	246	109	147	131	152	136	174	169	185	174	239	234	261
11	12	22 1/2	18	222	156	210	187	218	195	250	242	265	250	343	335	374
12 1/2	13 1/2	25	20	185	192	260	231	269	241	308	298	327	308	423	414	462
14	15 1/2	28 1/2	24	158	258	348	310	361	323	413	400	439	413	568	555	619
17	18 1/2	33 1/2	28	138	346	467	415	484	433	554	536	588	554	761	744	830
19	20 1/2	38	32	120	446	602	535	624	558	714	691	758	714	981	959	1070
21	22 1/2	43	34	112	572	772	686	801	715	915	887	972	915	1258	1230	1373
26	28 1/2	52	42	93	838	1131	1006	1174	1048	1341	1299	1425	1341	1844	1801	2012
30	33	60	48	80	1096	1480	1316	1534	1370	1757	1699	1863	1757	2411	2356	2632
Mean eff. press., lbs.,....					20	27	24	28	25	32	31	34	32	44	43	48
Ratio of expansion .....					13 1/2		16 1/4		10		12 1/4		6 3/4		8 1/4	
Cyl. condensation, %....					18	18	20	20	15	15	18	18	12	12	14	14
St. per I.H.P. hour, lbs.					17.3	16.6	16.6	15.2	17.0	16.4	16.3	15.8	17.5	17.0	16.8	16.0

## Triple-expansion Engines, Non-condensing — Receiver only Jacketed.

Diameter Cylinders, inches.			Stroke, inches.	Revolutions per Minute.	Horse-power when cutting off at 42% of Stroke in First Cylinder.		Horse-power when cutting off at 50% of Stroke in First Cylinder.		Horse-power when cutting off at 67% of Stroke in First Cylinder.	
					180 lbs.	200 lbs.	180 lbs.	200 lbs.	180 lbs.	200 lbs.
H.P.	I.P.	L.P.								
43/4	7 1/2	12	10	370	55	64	70	84	95	108
5 1/2	8 1/2	13 1/2	12	318	70	81	90	106	120	137
6 1/2	10 1/2	16 1/2	14	277	104	121	133	158	179	204
7 1/2	12	19	16	246	136	158	174	207	234	267
9	14 1/2	22 1/2	18	222	195	226	250	296	335	382
10	16	25	20	185	241	279	308	366	414	471
11 1/2	18	28 1/2	24	158	323	374	413	490	555	632
13	22	33 1/2	28	138	433	502	554	657	744	848
15	24 1/2	38	32	120	558	647	714	847	959	1093
17	27	43	34	112	715	829	915	1089	1230	1401
20	33	52	42	93	1048	1215	1341	1592	1801	2053
23 1/2	38	60	48	80	1370	1589	1754	2082	2356	2685
Mean eff. press., lbs.,.....					25	29	32	38	43	49
No. of expansions.....					16		13		10	
Cyl. condensation, %....					14		12		10	
Steam p. I.H.P.p.hr., lbs.					20.76	19.36	19.25	17.00	17.89	17.20
Lbs. coal at 8lb. evap., lbs.					2.59	2.39	2.40	2.12	2.23	2.15

Triple-expansion Engines — Condensing — Steam-jacketed.

Diameter Cylinders, inches.			Stroke, inches.	Revolutions per Minute.	Horse-power when cutting off at 1/4 Stroke in First Cyl.			Horse-power when cutting off at 1/3 Stroke in First Cyl.			Horse-power when cutting off at 1/2 Stroke in First Cyl.			Horse-power when cutting off at 3/4 Stroke in First Cyl.		
H.P.	I.P.	L.P.			120 lbs.	140 lbs.	160 lbs.	120 lbs.	140 lbs.	160 lbs.	120 lbs.	140 lbs.	160 lbs.	120 lbs.	140 lbs.	160 lbs.
43/4	71/2	12	10	370	35	42	48	44	53	59	57	72	84	81	97	110
51/2	81/2	13 1/2	12	318	45	53	62	56	67	76	73	92	107	104	123	140
61/2	10 1/2	16 1/2	14	277	67	79	92	83	100	112	108	137	159	154	183	208
71/2	12	19	16	246	87	103	120	109	131	147	141	180	208	201	239	272
9	14 1/2	22 1/2	18	222	125	148	172	156	187	211	203	257	299	289	343	390
10	16	25	20	185	154	183	212	192	231	260	250	317	368	356	423	481
11 1/2	18	28 1/2	24	158	206	245	284	258	310	348	335	426	494	477	568	645
13	22	33 1/2	28	138	277	329	381	346	415	467	450	571	663	640	761	865
15	24 1/2	38	32	120	357	424	491	446	535	602	580	736	854	825	981	1115
17	27	43	34	112	458	543	629	572	686	772	744	944	1095	1058	1258	1430
20	33	52	42	93	670	796	922	838	1006	1131	1089	1383	1605	1551	1844	2096
23 1/2	38	60	48	80	877	1041	1206	1096	1316	1480	1424	1808	2099	2028	2411	2740
Mean eff. press., lbs. . . . .					16	19	22	20	24	27	26	33	38.3	37	44	50
No. of expansions. . . . .					26.8			20.1			13.4			8.9		
Cyl. condensation, % . . . . .					19	19	19	16	16	16	12	12	12	8	8	8
St. p. I.H.P. p. hr., lbs. . . . .					14.7	13.9	13.3	14.3	13.9	13.2	14.3	13.6	13.0	15.7	14.9	14.7
Coal at 8 lbs. evap., lbs. . . . .					1.8	1.73	1.66	1.78	1.7	1.65	1.78	1.70	1.62	1.96	1.86	1.72

The Willans Law. Total Steam Consumption at Different Loads.

— Mr. Willans found with his engine that when the total steam consumption at different loads was plotted as ordinates, the loads being abscissas, the result would be a straight inclined line cutting the axis of ordinates at some distance above the origin of coördinates, this distance representing the steam consumption due to cylinder condensation at zero load. This statement applies generally to throttling engines, and is known as the Willans law. It applies also approximately to automatic cut-off engines of the Corliss, and probably of other types, up to the most economical load. In Mr. Barrus's book there is a record of six tests of a 16 x 42-in. Corliss twin-cylinder non-condensing engine, which gave results as follows:

I.H.P. . . . . .	37	100	146	222	250*	287	342
Feed-water per I.H.P. hour. . . . .	73.63	38.28	31.47	25.83	25.0*	25.39	25.91
Total feed-water per hour. . . . .	2724	3825	4595	5734	6250	7287	8861

\* Interpolated from the plotted curve.

The first five figures in the last line plot in a straight line whose equation is  $y = 2122 + 16.55 \text{ H.P.}$ , and a straight line through the plotted position of the last two figures has the equation  $y = 28.62 \text{ H.P.} - 927$ . These two lines cross at 253 H.P., which is the most economical load, the water rate being 24.96 lbs. and the total feed 6314 lbs. The figure 2122 represents the constant loss due to cylinder condensation, which is just over one-third of the total feed-water at the most economical load.

In Geo. H. Barrus's book on "Engine Tests" there is a diagram of condensation and leakage in tight or fairly tight simple engines using saturated steam. The average curve drawn through the several observations shows the condensation and leakage to be about as follows for different percentages of cut-off:

Cut-off, % of stroke = $l$ . . . . .	5	10	15	20	25	30	35	42
Condens. and leakage, % = $p$ . . . . .	60	43	35	29	24	20	17	15
$c = l \times p \div (100 - p)$ . . . . .	7.5	7.5	8	8.2	7.9	7.5	7.2	7.4

The figures in the last line represent the condensation and leakage as a percentage of the volume of the stroke of the piston. that is, in the same



terms as the first line, instead of as a percentage of the total steam supplied, in which terms the figures of the second line are expressed. They indicate that the amount of cylinder condensation is nearly a constant quantity for a given engine with a given steam pressure and speed, whatever may be the point of cut-off.

**Economy of Engines under Varying Loads.** (From Prof. W. C. Unwin's lecture before the Society of Arts, London, 1892.) — The general result of numerous trials with large engines was that with a constant load an indicated horse-power should be obtained with a consumption of  $1\frac{1}{2}$  lbs. of coal per I.H.P. for a condensing engine, and  $1\frac{3}{4}$  lbs. for a non-condensing engine, corresponding to about  $1\frac{3}{4}$  lbs. to  $2\frac{1}{8}$  lbs. per effective H.P.

In electric-lighting stations the engines work under a very fluctuating load, and the results are far more unfavorable. An excellent Willans non-condensing engine, which on full-load trials worked with under 2 lbs. per effective H.P. hour, in the ordinary daily working of the station used  $7\frac{1}{2}$  lbs. in 1886, which was reduced to 4.3 lbs. in 1890 and 3.8 lbs. in 1891. Probably in very few cases were the engines at electric-light stations working under a consumption of  $4\frac{1}{2}$  lbs. per effective H.P. hour. In the case of small isolated motors working with a fluctuating load, still more extravagant results were obtained.

At electric-lighting stations the load factor, viz., the ratio of the average load to the maximum, is extremely small, and the engines worked under very unfavorable conditions, which largely accounted for the excessive fuel consumption at these stations.

In steam-engines the fuel consumption has generally been reckoned on the indicated horse-power. At full-power trials this was satisfactory enough, as the internal friction is then usually a small fraction of the total.

Experiment has, however, shown that the internal friction is nearly constant, and hence, when the engine is lightly loaded, its mechanical efficiency is greatly reduced. At full load small engines have a mechanical efficiency of 0.8 to 0.85, and large engines might reach at least 0.9, but if the internal friction remained constant this efficiency would be much reduced at low powers. Thus, if an engine working at 100 I.H.P. had an efficiency of 0.85, then when the I.H.P. fell to 50 the effective H.P. would be 35 H.P. and the efficiency only 0.7. Similarly, at 25 H.P. the effective H.P. would be 10 and the efficiency 0.4.

Experiments on a Corliss engine at Creusot gave the following results:

Effective power at full load.....	1.0	0.75	0.50	0.25	0.125
Condensing, mechanical efficiency.....	0.82	0.79	0.74	0.63	0.48
Non-condensing, mechanical efficiency.	0.86	0.83	0.78	0.67	0.52

**Steam Consumption of Engines of Various Sizes.** — W. C. Unwin (*Cassier's Magazine*, 1894) gives a table showing results of 49 tests of engines of different types. In non-condensing simple engines, the steam consumption ranged from 65 lbs. per hour in a 5-horse-power engine to 22 lbs. in a 134-H.P. Harris-Corliss engine. In non-condensing compound engines, the only type tested was the Willans, which ranged from 27 lbs. in a 10-H.P. slow-speed engine, 122 ft. per minute, with steam-pressure of 84 lbs., to 19.2 lbs. in a 40-H.P. engine, 401 ft. per minute, with steam-pressure 165 lbs. A Willans triple-expansion non-condensing engine, 39 H.P., 172 lbs. pressure, and 400 ft. piston speed per minute, gave a consumption of 18.5 lbs. In condensing engines, nine tests of simple engines gave results ranging only from 18.4 to 22 lbs. In compound-condensing engines over 100 H.P., in 13 tests the range is from 13.9 to 20 lbs. In three triple-expansion engines the figures are 11.7, 12.2, and 12.45 lbs., the lowest being a Sulzer engine of 360 H.P. In marine compound engines, the Fusiya and Colchester, tested by Prof. Kennedy, gave steam consumption of 21.2 and 21.7 lbs.; and the Meteor and Tartar triple-expansion engines gave 15.0 and 19.8 lbs.

Taking the most favorable results which can be regarded as not exceptional it appears that in test trials, with constant and full load, the expenditure of steam and coal is about as follows:

Kind of Engine.	lbs. Per I.H.P. hour.		Per Effective H.P. hr.	
	Coal,	Steam,	Coal,	Steam,
Non-condensing.....	1.80	16.5	2.00	18.0
Condensing.....	1.50	13.5	1.75	15.8

These may be regarded as minimum values, rarely surpassed by the most efficient machinery, and only reached with very good machinery in the favorable conditions of a test trial.

**Small Engines and Engines with Fluctuating Loads** are usually very wasteful of fuel. The following figures, illustrating their low economy, are given by Prof. Unwin, *Cassier's Magazine*, 1894. Small engines in workshops in Birmingham, Eng.

Probable I.H.P. at full load.....	12	45	60	45	75	60	60
Average I.H.P. during observation.....	2.96	7.37	8.2	8.6	23.64	19.08	20.08
Coal per I.H.P. per hour during observation, lbs.	36.0	21.25	22.61	18.13	11.68	9.53	8.50

It is largely to replace such engines as the above that power will be distributed from central stations.

Tests at Royal Agricultural Society's show at Plymouth, Eng. *Engineering*, June 27, 1890.

Rated H.P.	Compound or Simple.	Diam. of Cylinders.		Stroke, ins.	Max. Steam-pressure.	Per Brake H.P. per hour.		Water per lb. Coal.
		h.p.	l.p.			Coal.	Water.	
5	simple	7	....	10	75	12.12	78.1 lbs.	6.1 lb.
3	compound	3	6	6	110	4.82	42.03 "	8.72 "
2	simple	4 1/2	....	7 1/2	75	11.77	89.9 "	7.64 "

**Steam-consumption of Engines at Various Speeds.** (Profs. Denton and Jacobus, *Trans. A. S. M. E.*, x, 722.) — 17 × 30 in. engine, non-condensing, fixed cut-off, Meyer valve. (From plotted diagrams.)

Revs. per min..	8	12	16	20	24	32	40	48	56	72	88
1/8 cut-off, lbs...	39	35	32	30	29.3	29	28.7	28.5	28.3	28	27.7
1/4 cut-off, lbs...	39	34	31	29.5	29	28.4	28	27.5	27.1	26.3	25.6
1/2 cut-off, lbs...	39	36	34	33	32	30.8	29.8	29.2	28.8	28.7	....

Steam-consumption of same engine; fixed speed, 60 revs. per minute. Varying cut-off compared with throttling-engine for same horse-power and boiler-pressures:

Cut-off, fraction of stroke ...	0.1	0.15	0.2	0.25	0.3	0.4	0.5	0.6	0.7	0.8
Steam, 90 lbs...	29	27.5	27	27	27.2	27.8	28.5	...	...	...
Steam, 60 lbs...	39	34.2	32.2	31.5	31.4	31.6	32.2	34.1	36.5	39

Throttling-engine, 7/8 cut-off, for corresponding horse-powers.

Steam, 90 lbs...	42	37	33.8	31.5	29.8	...	...	...	...	...
Steam, 60 lbs...	...	50.1	49	46.8	44.6	41	...	...	...	...

Some of the principal conclusions from this series of tests are as follows:

1. There is a distinct gain in economy of steam as the speed increases for 1/2, 1/8, and 1/4 cut-off at 90 lbs. pressure. The loss in economy for about 1/4 cut-off is at the rate of 1/12 lb. of water per I.H.P. per hour for each decrease of a revolution per minute from 86 to 26 revolutions, and at the rate of 5/8 lb. of water below 26 revolutions. Also, at all speeds the 1/4 cut-off is more economical than either the 1/2 or 1/8 cut-off.

2. At 90 lbs. boiler-pressure and above 1/3 cut-off, to produce a given H.P. requires about 20% less steam than to cut off at 7/8 stroke and regulate by the throttle.

3. For the same conditions with 60 lbs. boiler-pressure, to obtain, by throttling, the same mean effective pressure at 7/8 cut-off that is obtained by cutting off about 1/3, requires about 30% more steam than for the latter condition.

**Capacity and Economy of Steam Fire Engines.** (*Eng. News*, Mar. 28, 1895.)—Tests of fire engines by Dexter Brackett for the Board of Fire Commissioners, Boston, Mass. are tabulated on p. 994.

## Results of Tests of Steam Fire Engines.

No. of engine.	Boiler heating Surface.	Coal per sq. ft. of grate, per hour.	Water evap. per lb. coal, from and at 212°.	Av. steam pressure.	Av. water pressure.	Duty, ft.-lbs. per 100 lbs. of coal.	Av. water pumped per min.
		lbs.	lbs.	lbs.	lbs.		galls.
1.....	101.0	191.0	2.26	90.2	143.2	7,619,800	549
1.....		184.0		92.3	124.0	9,632,700	499
2.....	85.0	191.0	2.66	78.4	123.3	5,900,000	535
3.....	74.0	141.6	3.57	75.7	113.8	5,882,000	482
4.....	86.5	138.4	2.88	71.5	136.4	8,112,900	459
5.....	86.0	163.7		102.7	121.2	8,736,300	449
5.....		103.3	5.87	72.1	119.6	14,026,000	545
6.....	86.0	181.6	3.45	92.7	143.0	9,678,400	536
7.....	112.0	117.3	4.94	68.8	119.2	10,201,600	596
8.....	140.5	172.1	3.51	101.3	112.8	7,758,300	910
9.....	174.0	142.5	4.49	76.5	111.5	7,187,400	482
10.....	225.0	91.1	4.22	59.0	102.1	6,482,100	419
10.....		151.4	4.10	87.8	126.8	7,993,400	564
11.....	229.0	148.4	3.76	74.7	128.1	7,265,000	572

Nos. 1, 2, 3 and 4, Amoskeag engines; Nos. 5, 6, 7 and 8, Clapp & Jones; Nos. 9, 10, 11, Silsby. The engines all show an exceedingly high rate of combustion, and correspondingly low boiler efficiency and pump duty.

**Economy Tests of High-speed Engines.** (F. W. Dean and A. C. Wood, *Jour. A. S. M. E.*, June, 1908.) — Some of these engines had been in service for a long time, and therefore their valves may not have been in the best condition. The results may be taken as fairly representing the economy of average engines of the type, under usual working conditions. The engines were all non-condensing. The 16 × 15-in. engine was vertical, the others horizontal. They were all direct-connected to generators.

No. of Test.	1	2	3	4
Size of engine, ins....	15 × 14	16 × 15	14 × 12	16 × 14
Hours in service.....	15,216	20,000	28,644	719
Revs. per min.....	240	240	300	270
Valves.....	1 flat	1 flat	1 flat	4 flat
Generator, K.W.....	100	2-50	2-40	125
Steam per I.H.P.-hr...	37.2, † 36.2*	36.7, † 35.8	31.7, † 32.0	37.5,* 36.7
Steam per K.W.-hr...	60.2, 58.4	61.0 59.7	57.1, 57.4	54.9, 54.7

No. of Test.	5	6	7
Size of engine, ins....	18 × 18	15 × 16	12 × 18
Hours in service.....	32,000	5,600	10,800
Revs. per min.....	220	250	190
Valves.....	1 piston	1 piston	{ 2 flat inlet 2 Corliss exh.
Generator, K.W.....	150	100	75
Steam per I.H.P.-hr...	39.8, † 34.7,* 29.5 †	36.3,* 33.6	44.0, † 36.7, 34.1 †
Steam per K.W.-hr...	61.8, 51.8, 43.4	55.2, 49.4	79.3, 60.5, 53.7

\*  $\frac{3}{4}$  load; †  $\frac{1}{2}$  load; ‡  $1\frac{1}{4}$  load; §  $1\frac{1}{2}$  load; the others full load.

Some of the conclusions of the authors from the results of these tests are as follows:

The performances of the perfectly balanced flat valve engines are so relatively poor as to disqualify them, unless this type of valve can be made with some mechanism by which wear will not increase leakage. The four valve engines, which were built to be more economical than single-valve



engines, have utterly failed in their object. The duplication of valves used in both four-valve engines simply increased the opportunity for leakage. The most economical result was obtained from a piston valve engine, No. 5, heavily loaded. With the lighter loads that are comparable the flat valve engine, No. 3, surpassed No. 5 in economy. The flat valve engines give a flatter load curve than the piston valve engines. Comparing the results of the flat valve engines, the most economical results were obtained from engine No. 3, which had a valve which automatically takes up wear, and if it does not cut, must maintain itself tight for long periods.

From the results we are justified in thinking that most high-speed engines rapidly deteriorate in economy. On the contrary, slower running Corliss or gridiron valve engines improve in economy for some time and then maintain the economy for many years. It is difficult to see that the speed is the cause of this, and it must depend on the nature of the valve.

The steam consumption of small single-valve high-speed engines non-condensing, is not often less than 30 lbs. per I.H.P. per hour. Two Watertown engines, 10 × 12 tested by J. W. Hill for the Philadelphia Dept. of Public Works in 1904, gave respectively 30.67 and 29.70 lbs. at full load, 61.8 and 63.9 I.H.P., and 28.87 and 29.54 lbs. at approximately half-load, 37.63 and 36.36 I.H.P.

**High Piston-speed in Engines.** (*Proc. Inst. M. E.*, July, 1883, p. 321.) — The torpedo boat is an excellent example of the advance towards high speeds, and shows what can be accomplished by studying lightness and strength in combination. In running at 22½ knots an hour, an engine with cylinders of 16 in. stroke will make 480 revolutions per minute, which gives 1280 ft. per minute for piston-speed; and it is remarked that engines running at that high rate work much more smoothly than at lower speeds, and that the difficulty of lubrication diminishes as the speed increases.

**A High-speed Corliss Engine.** — A Corliss engine, 20 × 42 in., has been running a wire-rod mill at the Trenton Iron Co.'s works since 1877, at 160 revolutions or 1120 ft. piston-speed per minute (*Trans. A. S. M. E.*, ii, 72). A piston-speed of 1200 ft. per min. has been realized in locomotive practice.

**The Limitation of Engine-speed.** (Chas. T. Porter, in a paper on the Limitation of Engine-speed, *Trans. A. S. M. E.*, xiv, 806.) — The practical limitation to high rotative speed in stationary reciprocating steam-engines is not found in the danger of heating or of excessive wear, nor, as is generally believed, in the centrifugal force of the fly-wheel, nor in the tendency to knock in the centers, nor in vibration. He gives two objections to very high speeds: First, that "engines ought not to be run as fast as they can be;" second, the large amount of waste room in the port, which is required for proper steam distribution. In the important respect of economy of steam, the high-speed engine has thus far proved a failure. Large gain was looked for from high speed, because the loss by condensation on a given surface would be divided into a greater weight of steam, but this expectation has not been realized. For this unsatisfactory result we have to lay the blame chiefly on the excessive amount of waste room. The ordinary method of expressing the amount of waste room in the percentage added by it to the total piston displacement, is a misleading one. It should be expressed as the percentage which it adds to the length of steam admission. For example, if the steam is cut off at 1/5 of the stroke, 8% added by the waste room to the total piston displacement means 40% added to the volume of steam admitted. Engines of four, five and six feet stroke may properly be run at from 700 to 800 ft. of piston travel per minute, but for ordinary sizes, says Mr. Porter, 600 ft. per minute should be the limit.

**British High-speed Engines.** (John Davidson, *Power*, Feb. 9, 1909.) — The following figures show the general practice of leading builders:

I.H.P.	50	100	200	500	750	1000	1500	2000
Revs. per min.,	600-700	550-600	500	350-375	325	250	200	160-180
Piston speed, ft. per min.	600	650	675	750	775	800	900	1000

Rapid strides have been made during the last few years, despite the

competition of the steam turbine. The single-acting type (Brotherhood, Willans and others) has been superseded by double-acting engines with forced lubrication. There is less wear in a high-speed than in a low-speed engine. A 500-H.P. 3-crank engine after running 7 years, 12 hours per day and 300 days per year, showed the greatest wear to be as follows: crank pins, 0.003 in.; main bearings, 0.003 in.; eccentric sheaves, 0.015 in.; crosshead pins, 0.005 in. All pins, where possible, are of steel, case-hardened. High-speed engines have at least as high economy and efficiency as any other type of engine manufactured. A triple-expansion mill engine, with steam at 175 lbs., vacuum 26 ins., superheat 100° F., gave results as shown below, [figures taken from curves in the original].

Fraction of full load.....	0.1	0.2	0.3	0.4	0.5	0.6	0.7	0.8	0.9	1.0
Lbs. steam per I.H.P. hour..	12.7	11.85	11.4	11.1	10.9	10.8	10.75	10.75	10.8	11.0
Lbs. steam per B.H.P. hour..	16.0	14.8	13.7	12.9	12.4	12.05	11.85	11.8	11.8	11.8

Owing to the forced lubrication and throttle-governing, the economical performance at light loads is relatively much better than in slow-speed engines. The piston valves render the use of superheat practicable. At 200° superheat the saving in steam consumption of a triple-expansion engine is 26%. [A curve of the relation of superheat to saving shows that the percentage of saving is almost uniformly 1.4% for each additional 10° from 0° to 160° of superheat.]

The method of governing small high-speed engines is by means of a plain centrifugal governor fixed to the crank shaft and acting directly on a throttle. Several makers use a governor which at light loads acts by throttling, and at heavy loads by altering the expansion in the high-pressure cylinder. The crank-shaft governor used in America has been found impracticable for high speeds, except perhaps for small engines.

**Advantage of High Initial and Low Back Pressure.**—The theoretical advantage due to the use of high steam pressure and low back pressure or high vacuum is shown in the following table, which gives the efficiencies of an ideal engine operating on the Rankine cycle with different initial and back pressures, using dry saturated steam. The method of calculating the Rankine cycle efficiency, and a table showing the efficiencies with superheated steam will be found under Steam Turbines, page 1089.

#### Rankine Cycle Efficiencies—Saturated Steam.

Initial Pressure, Absolute, Lb.	Vacuum, In. of Mercury.					
	0	26	27	28	28.5	29
	Efficiencies, Per Cent.					
100.....	13.9	23.6	24.8	26.3	27.4	28.9
150.....	16.7	25.9	27.0	28.4	29.4	30.8
200.....	18.7	27.4	28.5	29.9	30.9	32.2
225.....	19.4	28.0	29.1	30.5	31.4	32.7
250.....	20.0	28.6	29.7	31.0	32.0	33.2

In practice the efficiencies given in the above table cannot be reached on account of the imperfection of the engine and its losses due to cylinder condensation, leakage, radiation and friction. The relative advantages of high pressure and low back pressure are probably proportional to the figures in the table, provided the expansion is divided into two or more stages at pressures above 100 lb. The possibility of obtaining very high vacua is limited by the temperature of the condensing water available and by the imperfections of the air pump. The use of high initial pressures is limited by the safe working pressure of the boiler and engine.

**Comparison of the Economy of Compound and Single-cylinder Corliss Condensing Engines, each expanding about Sixteen Times.** (D.S. Jacobus, *Trans., A. S. M. E.*, xii, 943.)

The engines used in obtaining comparative results are located at Stations I and II of the Pawtucket Water Co.

The tests show that the compound engine is about 30% more economical than the single-cylinder engine. The dimensions of the two engines are as follows: Single 20 × 48 ins.; compound 15 and 30 1/8 × 30 ins. The steam used per I.H.P. hour was: single 20.35 lbs., compound 13.73 lbs.

Both of the engines are steam-jacketed, practically on the barrels only, with steam at full boiler-pressure, viz., single 106.3 lbs., compound 127.5 lbs.

The steam-pressure in the case of the compound engine is 127 lbs., or 21 lbs. higher than for the single engine. If the steam-pressure be raised this amount in the case of the single engine, and the indicator-cards be increased accordingly, the consumption for the single-cylinder engine would be 19.97 lbs. per hour per horse-power.

**Two-cylinder vs. Three-cylinder Compound Engine.** — A Wheelock triple-expansion engine, built for the Merrick Thread Co., Holyoke, Mass., is constructed so that the intermediate cylinder may be cut out of the circuit and the high-pressure and low-pressure cylinders run as a two-cylinder compound, using the same conditions of initial steam-pressure and load. The diameters of the cylinders are 12, 16, and 24 13/32 ins., the stroke of the first two being 36 ins. and that of the low-pressure cylinder 48 ins. The results of a test reported by S. M. Green and G. I. Rockwood, *Trans. A. S. M. E.*, vol. xiii, 647, are as follows: In lbs. of dry steam used per I.H.P. per hour, 12 and 24 13/32 in. cylinders only used, two tests 13.06 and 12.76 lbs., average 12.91. All three cylinders used, two tests 12.67 and 12.90 lbs., average 12.79. The difference is only 1%, and would indicate that more than two cylinders are unnecessary in a compound engine, but it is pointed out by Prof. Jacobus, that the conditions of the test were especially favorable for the two-cylinder engine, and not relatively so favorable for the three cylinders. The steam-pressure was 142 lbs. and the number of expansions about 25. (See also discussion on the Rockwood type of engine, *Trans. A. S. M. E.*, vol. xvi.)

**Economy of a Compound Engine.** (D. S. Jacobus, *Trans. A. S. M. E.*, 1903.) — A Rice & Sargent engine, 20 and 40 × 42 ins., was tested with steam about 149 lbs., vacuum 27.3 to 28.8 ins. or 0.82 to 1.16 lbs. absolute. r.p.m. 120 to 122. with results as follows:

I.H.P. ....	1004	853	820	627	491	340
Water per I.H.P. per hr. . .	12.75	12.33	12.55	12.10	13.92	14.58
B.T.U. per I.H.P. per min.	231.8	226.3	229.9	222.7	256.8	267.7

**The Lentz Compound Engine** is described in *The Engineer* (London), July 10, 1908. It is the latest development of the reciprocating engine with four double-seated poppet valves to each cylinder, each valve operated by a separate eccentric mounted on a lay-shaft driven by bevel-gearing from the main shaft. The throw of the high-pressure steam eccentrics is varied by slide-blocks which are caused to slide along the lay-shaft by the action of a centrifugal inertia governor, which is also mounted on the lay-shaft. No elastic packing is used in the engine, the piston-rod stuffing box being fitted with ground cast-iron rings, and the valve stems being provided with grooves and ground to fit long bushings to 0.001 in. Two tests of a Lentz engine built in England, 14 1/2 and 24 3/4 by 27 1/2 in., gave results as follows:

Saturated steam, 170 lbs., vacuum 26 in., I.H.P. 366, steam per I.H.P. per hour 12.3 lbs. Steam 170 lbs. superheated 150° F., vac. 26 in., I.H.P. 366, steam per I.H.P. per hour, 10.4 lbs. Revs. per min. in both cases 167. Piston speed 767 ft. per min. Engines are built for speeds up to 900 ft. per min., and up to 350 r.p.m. The Lentz engine is built in the United States by the Erie City Iron Works.

**The Stumpf Uniflow Engine** is a single cylinder engine with a very long piston and with exhaust ports in the middle of the cylinder which are uncovered as the piston travels beyond them. The inlet ports are at the ends. The exhaust steam therefore does not have to flow back to the ends of the cylinder in order to escape, and the cooling of the ends and of the ports is thereby avoided. It is claimed that this single cylinder engine gives a steam economy equal to that of a compound engine. Uniflow engines are built by Nordberg Mfg. Co., Milwaukee.



### Steam Consumption of Sulzer Compound and Triple-expansion Engines with Superheated Steam.

The figures in the table below were furnished to the author in 1902 by Sulzer Bros., Winterthur, Switzerland. Results of official tests:

Saturated Steam.					Engine.	Superheated Steam.				
Initial Press., Lb.	Temp. of Steam, ° F.	Vacuum, Inches.	I.H.P.	Steam per I.H.P.-Hr., Lb.		Initial Press., Lb.	Temp. of Steam, ° F.	Vacuum, Inches.	I.H.P.	Steam per I.H.P.-Hr., Lb.
130	356	26.4	850	13.30	A	132	428	26.4	842	12.05
136	357	28	481	13.00		122	482	26.6	1719	12.42
134	356	28	750	13.10	B	135	547	28	515	11.32
135	356	27.6	1078	14.10		132	533	27.8	788	11.52
130	358	28.2	1076	14.10	C	134	546	27.2	1100	11.88
129	358	28	1316	14.50		132	496	28.3	1071	11.73
190	397	27.2	2880	11.28	D	136	527	*	1021	15.37
196	381	26.2	3040	11.57	E	188	606	28	2860	8.97
135	Superheated Steam.				F G	189	613	27	2908	9.41
	557	26.4	519	10.80†		127	655	27.2	788	9.91†
554	26.4	347	10.35†	127		664	27.2	797	9.68†	
135	554	26.4	347	10.35†		128	572	27.1	788	10.70†

	Normal, H.P.	Cylinders, In.	R.P.M.
A	1500 to 1800	30.5 & 49.2 × 59.1	83
B	800 to 1000	24 & 40.4 × 51.2	83
C	950 to 1150	26 & 42.3 × 51.2	86
D	3000 triple expan.	32 <sup>1</sup> / <sub>4</sub> , 47 <sup>1</sup> / <sub>4</sub> , & 58 × 59	85
E	3000 triple expan.	34, 49, & 61 × 51	83.5
F	400 to 500	17.7 & 30.5 × 35.4	110
G	1000 to 1200	26.9 & 47.2 × 66.9	65

\* Non-condensing. † With intermediate superheating. Temperature of steam at entrance to low-pressure cylinder, 307 to 349° F.

**Test of a Non-condensing Engine with Superheated Steam.**—Prof. J. A. Moyer reports in *Power*, Dec. 2, 1913, the following results of tests of a simple Lentz horizontal engine, cylinder, 19<sup>1</sup>/<sub>32</sub> in. × 20<sup>15</sup>/<sub>16</sub> in. stroke, 207 to 211 r.p.m. Steam pressure, absolute, 170.1 to 171.9 lb. Back pressure, 0 to 0.34 in. of mercury.

Indicated horse-power.....	162.7	227.6	282.1	322.5
Steam per I.H.P. hour, lb.....	17.25	15.78	15.24	15.48
Superheat, deg. F.....	98.3	139.4	141.5	159.7

**Saving of Steam due to Superheating.**—The following figures are given by Power Specialty Co., makers of the Foster superheater.

A 3300 horse-power Lentz cross-compound engine having 37<sup>1</sup>/<sub>2</sub>-in. and 63-in. cylinders, 55-in. stroke, at Charlottenburg, Germany, with 192-lb. gage pressure, 26-in. vacuum, 107 revs. per min., gave the following steam consumption:

Temp. of Steam.	Super-heat.	Load.	1/4	1/2	3/4	1/1	5/4
			570°	185° F.	Steam per I.H.P. hr., lb....	11.1	10.1
660°	275° F.	Steam per I.H.P. hr., lb....	10.6	9.7	9.0	8.8	9.2

The saving in steam effected by superheating 100 degrees, as compared with saturated steam, is, approximately, for steam turbines, 10 per cent; triple-expansion engines, 12 per cent; compound engines, 14 per cent; simple engines, 18 per cent and over.

Tests of Buckeye engines, simple, 12 × 16 in., and compound, 10 and 17½ × 16 in., with steam at 100 to 110 lb. pressure, gave the following:

Engine.	Per Cent of Rated Load.	Degrees of Superheat.				
		0	50	100	150	200
		Lb. Steam per I.H.P. Hr.				
Simple, non-condensing . . . . .	30	35	28	24	21.5	19.5
Simple, non-condensing . . . . .	50	31.5	25.5	22	19	17.5
Simple, non-condensing . . . . .	100	28.5	24.0	20	18	17.5
Compound, non-condensing . . . . .	100	.....	.....	17.5	15.5	14.6
Compound, condensing . . . . .	100	18	16.5	14	12.5	11.5

**Steam Consumption of Different Types of Engines.**

Tests of a Ridgway 4-valve non-condensing engine, 19 × 18 in., at 200 r.p.m. and 100 lb. pressure, are reported in *Power*, June, 1909, as follows:

Load . . . . .	1/4	1/2	3/4	Full	11/4
Steam per I.H.P. hour . . . . .	30.7	24.4	23.2	23.8	25.4

The best result obtained at 130 lb. pressure was 21.6 lb.; at 115 lb. pressure, 22.6 lb.; and at 85 lb. pressure, 24.3 lb. Maintained economy in this type of engine is dependent upon reduction of unnecessary over-travel, properly fitted valves, valves which do not span a wide arc, close approach of the movement of the valves to that of a Corliss engine, and good materials.

The probable steam consumption of condensing engines of different types with different pressures of steam is given in a set of curves by R. H. Thurston and L. L. Brinsmade, *Trans. A. S. M. E.*, 1897, from which curves the following approximate figures are derived.

Steam pressure, absolute, lbs. per sq. in.

	400	300	250	200	150	100	75	50
Ideal Engine (Rankine cycle)	6.95	7.5	7.9	8.45	9.20	10.50	11.40	12.9
Quadruple Exp. Wastes 20%	8.75	9.15	9.75	10.50	11.60	13.0	14.0	15.6
Triple Exp. Wastes 25%	9.25	9.95	10.50	11.15	12.30	14.0	15.1	16.7
Compound. Wastes 33%	10.50	11.25	11.80	12.70	13.90	15.6	16.9	18.9
Simple Engine. Wastes 50%	14.00	15.00	15.80	16.80	18.40	20.4	22.7	25.2

The same authors give the records of tests of a three-cylinder engine at Cornell University, cylinders 9, 16 and 24 ins., 36-in. stroke, first as a triple-expansion engine; second, with the intermediate cylinder omitted, making a compound engine with a cylinder ratio of 7 to 1; and third, omitting the third cylinder, making a compound engine with a ratio of a little over 3 to 1. The boiler pressure in the first case was 119 lbs., in the second 115, and in the third 117 lbs. Charts are given showing the steam consumption per I.H.P. and per B.H.P. at different loads, from which the following figures are taken.

Indicated Horse-power . . . . .	Steam consumption per I.H.P. per hour.							
	40	60	80	100	110	120	130	
Triple Exp. . . . .	19.1	16.7	15.3	14.2	13.7	13.8	14.4	
Comp. 7 to 1 . . . . .	19.6	18.2	17.0	16.3	16.	15.8	15.8	
Comp. 3 to 1 . . . . .	19.7	18.4	18.1	18.5	...	...	...	
Indicated Horse-power . . . . .	Steam consumption per B.H.P. hour.							
	30.5	23.0	19.6	17.1	16.2	16.2	16.7	
	26.2	21.7	19.3	18.7	18.5	18.4	18.5	
	23.4	20.6	20.	20.	...	...	...	

The most economical performance was as follows:

	Triple	Comp. 7 to 1	Comp. 3 to 1
Indicated Horse-power . . . . .	112.7	130.0	67.7
Steam per I.H.P. hour . . . . .	13.68	15.8	18.03

A test of a 7500-H.P. engine, at the 59th St. Station of the Interborough Rapid Transit Co., New York, is reported in *Power*, Feb., 1906. It is a double cross compound engine, with horizontal h.p. and vertical l.p. cylinders. With steam at 175 lbs. gauge and vacuum 25.02 ins., 75 r.p.m. it developed 7365 I.H.P., 5079 K.W. at switchboard. Friction and electrical losses 417.3 K.W. Dry steam per K.W. hour 17.34 lbs.; per I.H.P. hour, 11.96 lbs.

A test of a Fleming 4-valve engine, 15 and 40.5 in. diam., 27-in. stroke, positive-driven Corliss valves, fly-wheel governor, is reported by B. T. Allen in *Trans. A. S. M. E.*, 1903. The following results were obtained. The speed was above 150 r.p.m. and the vacuum 26 in.

Fraction of full load about.....	1/6	5/8	7/10	Full load	1.1
Horse-power.....	87.1	321.5	348.3	501.6	553.5
Steam per I.H.P. hour.....	14.42	13.59	12.33	12.66	12.7

**Relative Economy of Compound Non-condensing Engines under Variable Loads.** — F. M. Rites, in a paper on the Steam Distribution in a Form of Single-acting Engine (*Trans. A. S. M. E.*, xiii, 537), discusses an engine designed to meet the following problem: Given an extreme range of conditions as to load or steam-pressure, either or both, to fluctuate together or apart, violently or with easy gradations, to construct an engine whose economical performance should be as good as though the engine were specially designed for a momentary condition — the adjustment to be complete and automatic. In the ordinary non-condensing compound engine with light loads the high-pressure cylinder is frequently forced to supply all the power and in addition drag along with it the low-pressure piston, whose cylinder indicates negative work. Mr. Rites shows the peculiar value of a receiver of predetermined volume which acts as a clearance chamber for compression in the high-pressure cylinder. The Westinghouse compound single-acting engine is designed upon this principle. The following results of tests of one of these engines rated at 175 H.P. for most economical load are given:

**WATER RATES UNDER VARYING LOADS, LBS. PER H.P. PER HOUR.**

Horse-power.....	210	170	140	115	100	80	50
Non-condensing.....	22.6	21.9	22.2	22.2	22.4	24.6	28.8
Condensing.....	18.4	18.1	18.2	18.2	18.3	18.3	20.4

**Efficiency of Non-condensing Compound Engines.** (W. Lee Church, *Am. Mach.*, Nov. 19, 1891.) — The compound engine, non-condensing, at its best performance will exhaust from the low-pressure cylinder at a pressure 2 to 6 pounds above atmosphere. Such an engine will be limited in its economy to a very short range of power, for the reason that its valve-motion will not permit of any great increase beyond its rated power, and any material decrease below its rated power at once brings the expansion curve in the low-pressure cylinder below atmosphere. In other words, decrease of load tells upon the compound engine somewhat sooner, and much more severely, than upon the non-compound engine. The loss commences the moment the expansion line crosses a line parallel to the atmospheric line, and at a distance above it representing the mean effective pressure necessary to carry the frictional load of the engine. When expansion falls to this point the low-pressure cylinder becomes an air-pump over more or less of its stroke, the power to drive which must come from the high-pressure cylinder alone. Under the light loads common in many industries the low-pressure cylinder is thus a positive resistance for the greater portion of its stroke. A careful study of this problem revealed the functions of a fixed intermediate clearance, always in communication with the high-pressure cylinder, and having a volume bearing the same ratio to that of the high-pressure cylinder that the high-pressure cylinder bears to the low-pressure. Engines laid down on these lines have fully confirmed the judgment of the designers. The effect of this constant clearance is to supply sufficient steam to the low-pressure cylinder under light loads to hold its expansion curve up to atmosphere, and at the same time leave a sufficient clearance volume in the high-pressure cylinder to permit of governing the engine on its compression under light loads.

Tests of two non-condensing Corliss engines by G. H. Barrus are reported in *Power*, April 27, 1909. The engines were built by Rice & Sargent. One is a simple engine 22 × 30, and the other a tandem



compound 22 and 36 × 36 ins. Both engines are jacketed in both heads, and the compound engine has a reheating receiver with 0.6 sq. ft. of brass pipes per rated H.P. (600). The guarantees were: compound engine, not to exceed 19 lbs. of steam per I.H.P. per hour, with 130 lbs. steam pressure and 1 lb. back pressure in the exhaust pipe, and the simple engine not to exceed 23 lbs. The friction load, engine run with the brushes off the generator and the field not excited, was not to exceed 4½ H.P. in either engine. The results were: compound engine, 99.2 r.p.m., 608.3 H.P.; 18.33 lbs. steam per I.H.P. per hour; friction load 3.8% of 600 H.P.; simple engine, 98.5 r.p.m.; 306.2 I.H.P.; 20.98 lbs. per I.H.P. per hour; friction 3.6% of 300 H.P.

A single-cylinder engine 12 × 12 ins., made by the Buffalo Forge Co., was tested by Profs. Reeve and Allen. (*El. World*, May 23, 1903.) Some of the results were:

I.H.P. . . . . .	16.39	37.20	56.00	69.00	74.10	81.4	89.3	125.9*	86.42†
Water-rate. . . . .	52.3	35.3	33.3	31.9	30.6	34.6	33.1	27.6	27.5

\* Steam pressure 125 lbs. gauge, all the other tests 80 lbs. † Condensing, other tests all non-condensing.

**Effect of Water contained in Steam on the Efficiency of the Steam-engine.** (From a lecture by Walter C. Kerr, before the Franklin Institute, 1891.) — Standard writers make little mention of the effect of entrained moisture on the expansive properties of steam, but by common consent rather than any demonstration they seem to agree that moisture produces an ill effect simply proportional to the percentage amount of its presence. That is, 5% moisture will increase the water rate of an engine 5%.

Experiments reported in 1893 by R. C. Carpenter and L. S. Marks, *Trans. A. S. M. E.*, xv, in which water in varying quantity was introduced into the steam-pipe, causing the quality of the steam to range from 99% to 58% dry, showed that throughout the range of qualities used the consumption of dry steam per indicated horse-power per hour remains practically constant, and indicated that the water was an inert quantity, doing neither good nor harm.

**Influence of Vacuum and Superheat on Steam Consumption.** (*Eng. Digest*, Mar., 1909.) — Herr Roginsky ("Die Turbine") discusses the economies effected by the use of superheat and high vacuums.

In a certain triple-expansion engine, working under good average conditions, there was found a saving of approximately 6% for each 10% increase in vacuum beyond 50%.

The Batulli-Tumlirz formula for superheated steam is:  $p(v + a) = RT$ , in which  $p$  = steam pressure in kgs. per sq. meter,  $v$  = cubic meters in 1 kg. of superheated steam at pressure  $p$ ,  $a = 0.0084$ ,  $R = 46.7$ , and  $T$  = absolute temperature in deg. C.

Using this expression, it is found that, neglecting the fuel used for superheating, for each 10° C. of superheat at pressures ranging from 100 to 185 lbs. per sq. in. there is an average increase of volume of 2.8%. The work done by the expansion of superheated steam, as shown by diagrams, is about 1.6% less for 10° of superheating, so that the net saving for each 10° of superheat is 2.8 - 1.6 = 1.2%, approx. (0.66% for each 10° F.).

Rateau's formula for the steam consumption ( $K$ ) per H.P.-hr. of an ideal steam turbine, in which the steam expands from pressure  $p_1$  to  $p_2$ , is

$$K = 0.85 (6.95 - 0.92 \log p_2) / (\log p_1 - \log p_2),$$

$K$  being in kilograms and  $p_1$  and  $p_2$  in kgs. per sq. meter. From this formula the following table is calculated, the values being transformed into British units.

$p_1$ Lbs. per sq. in.	Lbs. Steam at 50% Vacuum.	Reduction of Steam Consumption (%) by using a Vacuum of				
		60%	70%	80%	90%	95%
184.9	11.11	5.	11.1	18.1	27.8	34.6
156.5	11.75	5.8	11.8	19.3	28.8	36.4
128	12.57	6.6	12.9	20.5	20.8	38.5
99.6	13.84	7.6	14.4	22.	33.3	40.6

From the entropy diagram it is seen that in expanding from pressures in excess of 100 lbs. per sq.in. down to 1.42 lbs. absolute, approximately 1% more work is performed for every 10° F. of superheat. The effect of increasing the degree of vacuum is summed up in the following table:

Increasing the Vacuum from	Decreases Steam Consumption.	
	in Reciprocating Engines.	in Steam Turbines.
50% to 60%	5.8%	6.2%
50% to 70%	11.6%	12.6%
50% to 80%	17.3%	20.0%
50% to 90%	23.1%	30.1%
50% to 95%	26.0%	37.4%

In the last case (from 50% to 95%) the decrease in steam consumption is 44% greater for a steam turbine than for a reciprocating engine.

The following results of tests of a compound engine using superheated steam are reported in *Power*, Aug., 1905. The cylinders were 21 and 36 X 36 ins. The steam pressure was about 117 lbs. gauge. R.p.m. 100, vacuum 26.5 ins.

Test No.....	1	2	3	4	5	6
Indicated H.P.....	481	461	347	145	333	258
Superheat of steam entering h.p. cyl... 253° F		242°	221°	202°	232°	210°
B.T.U. supplied per I.H.P. per min....	198.2	201.7	197.6	192.1	194.0	194.0
B.T.U. theoretically required. Rankine cycle.....	142.4	142.5	130.2	128.0	126.0	128.5
Efficiency ratio.....	0.72	0.71	0.66	0.67	0.65	0.66
Thermal efficiency %	21.39	21.02	21.46	22.07	21.86	21.86
Lbs. steam per I.H.P. hour.....	9.098	9.267	8.886	8.585	8.682	8.742

**The Practical Application of Superheated Steam** is discussed in a paper by G. A. Hutchinson in *Trans. A. S. M. E.*, 1901. Many different forms of superheater are illustrated.

Some results of tests on a 3000-H.P., four-cylinder, vertical, triple-expansion Sulzer engine, using steam from Schmidt independently fired superheaters, are as follows. (*Eng. Rec.*, Oct. 13, 1900.)

Tests Using Steam.	Highly Superheated.			Mod- erately Super- heated	Saturated.	
Initial pressure in h.p. cyl. (absolute), lbs.....	187.3	195.5	188.4	190.3	194.6	195.9
Temp. of steam in valve chest, deg. F.....	582	585	614	531	381	381
Total I.H.P.....	2,900	2,779	2,868	2,850	2,951	2,999
Lbs. steam per I.H.P. hour	9.64	9.67	9.56	10.29	11.77	11.75
Watt hours per lb. of coal.	477	482	479	447	438	435

The saving due to the use of highly superheated steam is  $(482-438) \div 482 = 9.1\%$ .

Tests of a 4000-H.P. double-compound engine (Van den Kerchove, of Brussels) with superheated steam are reported in *Power*, Dec. 29, 1908. The cylinders are 34 1/4 and 60 ins., stroke 5 ft. Ratio of areas 2.97. The following are the principal results, the first figures given being for the full-load test, and the second (in parentheses) for the half-load test. Steam pressure at drier, 136.5 lbs. (137.9). R.p.m. 84.3 (84.06). Temp. of steam entering engine 519° F. (498), leaving l.p. cyl. 121.5° (121.5). Vacuum in condenser, ins., 27.5 (27). I.H.P. 3776 (2019). Steam per I.H.P. hour, lbs., 9.62 (9.60).

The saving due to the use of superheated steam is reported in numerous

tests as being all the way from less than 10% to more than 40%. The greater saving is usually found with engines that are the most inefficient with saturated steam, such as single-cylinder engines with light loads, in which the cylinder condensation is excessive.

R. P. Bolton (*Eng. Mag.*, May, 1907) states that tests of superheated steam in locomotives, by the Prussian Railway authorities in 1904, with 50°, 104° and 158° F. superheat, showed a saving of water respectively of 2.5, 10 and 16%, and a saving of coal of 2, 7 and 12%. Mr. Bolton's paper concludes with a long list of references on the subject of superheated steam. A paper by J. R. Bibbins in *Elec. Jour.*, March, 1906, gives a series of charts showing the saving made by different degrees of superheating in different types of engines, including steam turbines.

For description of the Foster superheater, see catalogue of the Power Specialty Co., New York.

The Wolf (French) semi-portable compound engine of 40 H.P. with superheater and reheater, the engine being mounted on the boiler, is reported by R. E. Mathot, *Power*, July, 1906, to have given a steam consumption as low as 9.9 lbs. per I.H.P. hour, and 10.98 lbs. per B.H.P. hour. The steam pressure in the boiler was 172.6 lbs., and was superheated initially to 657° F., and reheated to 361° before entering the l.p. cylinder. This is a remarkable record for a small engine.

A test of a Rice & Sargent cross-compound horizontal engine 16 and 28 × 42 ins., with superheated steam, is reported by D. S. Jacobus in *Trans. A. S. M. E.*, 1904. The steam pressure at the throttle was 140 lbs. gauge, the superheating was 350 to 400°, and the vacuum 25 to 26 ins., r.p.m. 102. In three tests with superheated and one with saturated, steam the results were:

I.H.P. developed.....	474.5	420.4	276.8	406.7
Water consumption per I.H.P. hour.....	9.76	9.56	9.70	13.84
Coal consumption per I.H.P. hour.....	1.265	1.257	1.288	1.497
B.T.U. per min. per I.H.P.....	205.0	203.7	208.8	248.2
Temp. of steam entering h.p. cyl.....	634	659	672	.....
Temp. of steam leaving h.p. cyl.....	346	331	288	262
Temp. of steam entering l.p. cyl.....	408	396	354	269
Temp. of steam leaving l.p. cyl.....	135	141	117	.....

**Performance of a Quadruple Engine.**—O. P. Hood (*Trans. A. S. M. E.*, 1906) describes a test of a high-duty air compressor, with four steam cylinders, 14.5, 22, 38 and 54 in. diam., 48-in. stroke. The clearances were respectively 6, 5.7, 4.4 and 3.5%. R.p.m. 57. Steam pressure, gauge, near throttle, 242.8 lbs., in 1st. receiver 120.7 lbs., in 2d, 30.8 lbs., in 3d, vac., — 1.24 ins. Moisture in steam near throttle, 5.74%. Steam in No. 1 receiver, dry; in No. 2, 17° superheat; in No. 3, 9° superheat. The engine has poppet valves on the h.p. cylinder and Corliss valves on the other cylinders. The feed-water heaters are four in number, in series, on the Nordberg system; No. 1 receives its steam from the exhaust of No. 4 cylinder; No. 2 from the jacket of No. 4 cyl.; No. 3 from the jackets of No. 3 cylinder and No. 3 reheater; No. 4 from the jacket of No. 2 cylinder. The reheaters are supplied with steam from the boilers. The temperatures of steam and water were as follows: Temperatures of steam: Fed to No. 1 engine, 403°; leaving receivers, No. 1, 351°; No. 2, 291°; No. 3, 216°. Exhaust entering preheater, 114°. Temperature corresponding to condenser pressure, 109.6°. Temperatures of water: Fed to preheater, 93°; fed to heaters, No. 1, 114°; No. 2, 173°; No. 3, 202°; No. 4, 269°; leaving heater No. 4 as boiler feed, 334°.

The principal results of the test are as follows:

Cylinder.....	1	2	3	4
I.H.P. developed in steam cylinders.....	181.47	256.96	275.71	275.56
I.H.P. used in the cylinders.....	220.04	222.12	226.20	214.84
Total indicated horse-power, steam cylinders.....	989.7			
Total horse-power used in air cylinders.....	883.2			
Total indicated horse-power of auxiliaries.....	11.0			
Horse-power representing friction of the machine.....	95.5			
Per cent of friction.....	9.65%			
Mechanical efficiency engine and compressor.....	90.35%			
Heat consumed by engine per hour per I.H.P., 10,157 B.T.U.; per B.H.P., 11,382 B.T.U. Equivalent standard coal consumption per				



hour assuming 10,000 B.T.U. imparted to the boiler per pound coal, per I.H.P., 1,016 lbs.; per B.H.P., 1,138 lbs. Dry steam per hour per I.H.P., 11.23 lbs.; per B.H.P., 12.58 lbs. Heat units consumed per minute, per I.H.P., 169.29 B.T.U.; per B.H.P., 189.70 B.T.U.

Efficiency of Carnot cycle between the temperature of incoming steam and that corresponding to pressure in the condenser...	34.0 %
Actual heat efficiency attained by this engine . . . . .	25.05 %
Relative efficiency compared with Carnot cycle . . . . .	73.69 %
Relative efficiency compared with Rankine cycle . . . . .	88.2 %
Duty, ft.-lbs. per million B.T.U. supplied . . . . .	194,930,000

This engine establishes a new low record for the heat consumed per hour per I.H.P., being 9% lower than that used by the Wildwood pumping engine reported in 1900. (See Pumping Engines.)

**The Use of Reheaters** in the receivers of multiple-expansion engines is discussed by R. H. Thurston in *Trans. A. S. M. E.*, xxi, 893. He shows that such receivers improve the economy of an engine very little unless they are also superheaters; in which case marked economy may be effected by the reduction of cylinder condensation. The larger the amount of cylinder condensation and the greater the losses, exterior and interior, the greater the effect of any given amount of superheating. The same statement will hold of the use of reheaters: the more wasteful the engine without them and the more effectively they superheat, the larger the gain by their use. A reheater should be given such area of heating surface as will insure at least moderate superheating.

**Influence of the Steam-jacket.** — Tests of numerous engines with and without steam-jackets show an exceeding diversity of results, ranging all the way from 30% saving down to zero, or even in some cases showing an actual loss. The opinions of engineers at this date (1894) is also as diverse as the results, but there is a tendency towards a general belief that the jacket is not as valuable an appendage to an engine as was formerly supposed. An extensive *résumé* of facts and opinions on the steam-jacket is given by Prof. Thurston in *Trans. A. S. M. E.*, xiv, 462. See also *Trans. A. S. M. E.*, xiv, 873 and 1340; xiii, 176; xii, 426 and 1340; and *Jour. F. I.*, April, 1891, p. 276. The following are a few statements selected from these papers.

The results of tests reported by the research committee on steam-jackets appointed by the British Institution of Mechanical Engineers in 1886, indicate an increased efficiency due to the use of the steam-jacket of from 1% to over 30%, according to varying circumstances.

Professor Unwin considers that "in all cases and on all cylinders the jacket is useful; provided, of course, ordinary, not superheated, steam is used; but the advantages may diminish to an amount not worth the interest on extra cost."

Professor Cotterill says: Experience shows that a steam-jacket is advantageous, but the amount to be gained will vary according to circumstances. In many cases it may be that the advantage is small. Great caution is necessary in drawing conclusions from any special set of experiments on the influence of jacketing.

In the Pawtucket pumping-engine, 15 and  $30\frac{1}{8} \times 30$  in., 50 revs. per min., steam-pressure 125 lbs. gauge, cut-off  $\frac{1}{4}$  in h.p. and  $\frac{1}{3}$  in l.p. cylinder, the barrels only jacketed, the saving by the jackets was from 1% to 4%.

The superintendent of the Holly Mfg. Co. (compound pumping-engines) says: "In regard to the benefits derived from steam-jackets on our steam-cylinders, I am somewhat of a skeptic. From data taken on our own engines and tests made I am yet to be convinced that there is any practical value in the steam-jacket."

Professor Schröoter from his work on the triple-expansion engines at Augsburg, and from the results of his tests of the jacket efficiency on a small engine of the Sulzer type in his own laboratory, concludes: (1) The value of the jacket may vary within very wide limits, or even become negative. (2) The shorter the cut-off the greater the gain by the use of a jacket. (3) The use of higher pressure in the jacket than in the cylinder produces an advantage. The greater this difference the better. (4) The high-pressure cylinder may be left unjacketed without great loss, but the other should always be jacketed.

The test of the Laketon triple-expansion pumping-engine showed a gain

of 8.3% by the use of the jackets, but Prof. Denton points out (*Trans. A. S. M. E.*, xiv, 1412) that all but 1.9% of the gain was ascribable to the greater range of expansion used with the jackets.

**Test of a Compound Condensing Engine with and without Jackets at different Loads.** (R. C. Carpenter, *Trans. A. S. M. E.*, xiv, 428.)—Cylinders 9 and 16 in. X 14 in. stroke; 112 lbs. boiler-pressure; rated capacity 100 H.P.; 265 revs. per min. Vacuum, 23 in. From the results of several tests curves are plotted, from which the following principal figures are taken.

Indicated H.P. ....	30	40	50	60	70	80	90	100	110	120	125
Steam per I.H.P. per hr.											
With jackets, lbs. ....	22.6	21.4	20.3	19.6	19	18.7	18.6	18.9	19.5	20.4	21.0
Without jackets, lbs. ....				22	20.5	19.6	19.2	19.1	19.3	20.1	....
Saving by jacket, %.....				10.9	7.3	4.6	3.1	1.0	-1.0	-1.5	....

This table gives a clue to the great variation in the apparent saving due to the steam-jacket as reported by different experimenters. With this particular engine it appears that when running at its most economical rate of 100 H.P., without jackets, very little saving is made by use of the jackets. When running light the jacket makes a considerable saving, but when overloaded it is a detriment.

At the load which corresponds to the most economical rate, with no steam in jackets, or 100 H.P., the use of the jacket makes a saving of only 1%; but at a load of 60 H.P. the saving by use of the jacket is about 11%, and the shape of the curve indicates that the relative advantage of the jacket would be still greater at lighter loads than 60 H.P.

**The Best Economy of the Piston Steam-Engine** at the Advent of the Steam Turbine is the subject of a paper by J. E. Denton at the International Congress of Arts and Sciences, St. Louis, 1904. (*Power* Oct. 26, 1905.) Prof. Denton says:

During the last two years the following records have been established:

(1) With an 850-H.P. Rice & Sargent compound Corliss engine, running at 120 r.p.m., having a 4 to 1 cylinder ratio, clearances of 4% and 7%, live jackets on cylinder heads and live steam in reheater, Prof. Jacobus found for 600 H.P. of load, with 150 lbs. saturated steam, 28.6 ins. vacuum, and 33 expansions, 12.1 lbs. of water per I.H.P., with a cylinder-condensation loss of 22%, and a jacket consumption of 10.7% of the total steam consumption.

(2) With a 250-H.P. Belgian poppet-valve compound engine, 126 r.p.m.. with 2.97 to 1 cylinder ratio, clearances of 4%, steam-chest jackets on barrels and head, and no reheater, Prof. Schröter, of Munich, found with 117 H.P. of load, 130 lbs. saturated steam, 27.6 ins. of vacuum, and 32 expansions, 11.98 lbs. of water per H.P. per hour, with a cylinder-condensation loss of 23.5%, and a jacket consumption of 7% of the total steam consumption in the high cylinder jacket and 7% in the low jacket.

(3) With the Westinghouse twin compound combined poppet-valve and Corliss-valve engine, at the New York Edison plant, running 76 r.p.m., with 5.8 to 1 cylinder ratio, clearances of 10.5% and 4%, without jackets or reheater, Messrs. Andrew, Whitham and Wells found for the full load of 5400 H.P., 185 lbs. steam pressure, 27.3 ins. vacuum, and 29 expansions, 11.93 lbs. of water per I.H.P. per hour, with an initial condensation of about 32%.

These facts show that the minimum water consumption of the compound engine of the present date, using saturated steam, is not dependent upon any particular cylinder ratio and clearance nor upon any system of jacketing, but that the essential condition is the use of a ratio of expansion of about 30, above which the cylinder-condensation loss is liable to prevail over the influence of the law of expansion. The conclusion appears warranted, therefore, that if this ratio of expansion is secured with any of the current cylinder and clearance ratios, and with any existing system of jackets and reheaters, or without them, a water consumption of 12.4 lbs. per horse-power is possible, and that a variation of 0.4 lb. below or above this figure may occur by the accidental favorable, or unfavorable, jacket and cylinder-wall expenses which are beyond the control of the designer.

*Compound Piston Engine Economy vs. that of Steam Turbine.*—In order to compare the economy of the piston engine with that of the steam tur-

bine, we must use the water consumption per brake horse-power, since no indicator card is possible from the turbine; and furthermore, we must use the average water consumption for the range of loads to which engines are subject in practice.

In all of the public turbine tests to date, with one exception the output was measured through the electric power of a dynamo whose efficiency is not given for the range of loading employed, so that the average brake horse-power is not known. This exception is the Dean and Main test of a 600-H.P. Westinghouse-Parsons turbine using saturated steam at 150 lbs. pressure, and a 28-in. vacuum. We may compare the results of this test with that of the 850-H.P. Rice & Sargent and of the 250-H.P. Belgian engine, by assuming that the power absorbed by friction in these engines is 3% of the indicated load plus the power shown by friction cards taken with the engine unloaded. The latter showed 5% of the rated power in the R. & S. engine and 8% in the Belgian engine. The results are:

Per cent of full load.....	41	75	100	125	Avg. 85%
	Lbs. Water per Brake H.P. Hour.				
600-H.P. Turbine.....	13.62	13.91	14.48	16.05	14.51
800-H.P. Comp. Engine.....	13.78	13.44	13.66	17.36	14.56
250 H.P. Belgian Engine.....	15.10	14.15	13.99	15.31	14.64

These figures show practical equality in economy of the types of engines. The full report of the Van den Kerchove Belgian engine is given in *Power*, June, 1903.

For large-sized units Prof. Denton compares the Elberfeld test of a Parsons turbine at the full load of 1500 electric H.P., allowing 5% for attached air pump, 95% for generator efficiency, with the 5400-H.P. Westinghouse compound engine at the New York Edison station, whose friction at full load was found to be 4%. The turbine with 150 lbs. steam and 28 ins. vacuum required 13.08 lbs. of saturated steam per B.H.P. hour, a gain of 4% over the 600-H.P. turbine. The engine with 18.5 lbs. boiler pressure gave 12.5 lbs. per B.H.P. hour. Crediting the turbine with the possible influence of the difference in size and steam pressure, there is again practical equality in economy between it and the piston engine.

*Triple-expansion Pumping Engines.* — The triple-expansion engine has failed to supplant the compound for electric light and mill service, because the gain in fuel economy due to its use was not sufficient to overcome its higher first cost, depreciation, etc. It is, however, almost universally used in marine practice, and also in large-sized pumping engines. Prof. Denton says: Pumping engines in the United States have been developed in the triple-expansion fly-wheel type to a degree of economy superior to that afforded by any compound mill or electric engine, and, for saturated steam, superior to that of the pumping engines of any other country. This is because their slow speed permits of greater benefit from jackets and reheaters and of less losses from wire-drawing and back pressure. These causes, together with the greater subdivision of the range of expansion, have resulted in records made between 1894 and 1900 of 11.22, 11.26 and 11.05 lbs. of saturated steam per I.H.P., with 175 lbs. steam pressure and from 25 to 33 expansions, in the cases of the Leavitt, Snow and Allis pumping engines, respectively, the corresponding heat consumption being by different dispositions of the jacket drainage, 204, 208 and 212 thermal units per I.H.P. minute; while later the Allis pump, with 185 lbs. steam pressure, has lowered the record to 10.33 lbs. of saturated steam per I.H.P., with 196 B.T.U. per H.P. minute.

*Gain from Superheating.* — In the Belgian compound engine above described, with steam at 130 lbs., vacuum 27.6 ins., the average consumption of saturated steam, between 45 and 125% of load, was 12.45 lbs. per I.H.P. hour, or 225 B.T.U. per I.H.P. minute. With steam superheated 224° F. the average consumption for the same loads was 10.09 lbs. per I.H.P. hour, computed to be equivalent to 209 B.T.U. per H.P. minute, a gain due to superheating of 7%. With steam superheated 307° and the load about 80% of rating the water consumption was 8.99 lbs. per I.H.P. hour, equivalent to 192 B.T.U. per H.P. minute. The same load with saturated steam requires 221 B.T.U., showing a gain due to superheating of 13%.

The best performance reported for superheated steam used in the tur-



bine is that of Brown & Boveri Parsons, Frankfort, 4000-H.P. machine, which, with 183 lbs. gauge pressure and 190° F. superheat, afforded 10.28 lbs. per B.H.P. hour, assuming a generator efficiency of 0.95. Reckoning from the feed temperature of its vacuum of 27.5 ins., the heat consumption is 214 B.T.U. per H.P. minute.

The heat consumption of the 250-H.P. Belgian compound engine per B.H.P. hour at the highest superheating of 307° F. is 220 B.T.U. The turbine, therefore, probably holds the record for brake horse-power economy over the piston engine for superheated steam by a margin of about 3%, although had the compound engine been of the same horse-power as the turbine, so that its friction load would be only 8% of its power instead of the 13% here allowed, it would have excelled the turbine in brake horse-power economy by a margin of about 2.5%.

*The Sulphur-dioxide Addendum.* — If the expansion in piston engines could continue until the pressure of 1 pound was attained before exhaust occurred, considerable more work could be obtained from the steam. This cannot be done, for two reasons: first, because the low cylinder would have to be about five times greater in volume, which is commercially impracticable; and, second, because the velocity of exit through the largest exhaust ports possible is so great that the frictional resistance of the steam makes the back pressure from 1 to 3 pounds higher than the condenser pressure in the best engines of ordinary piston speed.

All the work due to this extra expansion can be obtained by exhausting the steam at 6 lbs. pressure against a nest of tubes containing sulphur dioxide which is thereby boiled to a vapor at about 170 lbs. pressure.

Professor Josse, of Berlin, has perfected this sulphur-dioxide system of improvement, and reliable tests have shown that if cooling water of 65° is available, and to the extent of about twice the quantity usually employed for condensing steam under 28 ins. of vacuum, a sulphur-dioxide cylinder of about half the size of the high-pressure cylinder of a compound engine will do sufficient work to improve the best economy of such engines at least 15%. The steam turbine expands its steam to the pressure of its exhaust chamber, and as unlimited escape ports can be provided from this chamber to a condenser, it follows that the turbine can practically expand its steam to the pressure of the condenser. Therefore a steam turbine attached to a piston engine to operate with the latter's exhaust should effect the same saving as the sulphur-dioxide cylinder.

**Standard Dimensions of Direct-connected Generator Sets.** From a report by a committee of the A. S. M. E., 1901.

Capacity of unit, K.W.....	25	35	50	75	100	150	200
Revolutions per minute.....	310	300	290	275	260	225	200
Armature bore, center crank engines...	4	4	4 1/2	5 1/2	6	7	8
Armature bore, side-crank engines.....	4 1/2	5 1/2	6 1/2	7 1/2	8 1/2	10	11

The diameter of the engine shaft at the armature fit is 0.001 in. greater than the bore, for bores up to and including 6 ins., and 0.002 in. greater for bores 6 1/2 ins. and larger.

**Dimensions of Some Parts of Large Engines in Electric Plants.**—The *Electrical World*, Sept. 27, 1902, gives a table of dimensions of the engines in the five large power stations in New York City at that date. The following figures are selected from the table.

Name of station.....	Metro- politan.	Manhat- tan.	Kings- bridge.	Rapid Transit.	Edison.
Type of engine.....	Vert. Cross- Comp.	Double, 2 hor. 2 vert. Cyls.	Vert. Cross- Comp.	Double 2 hor. 2 vert. Cyls.	3 Cyl. Vert.
Rated H.P.....	4500	8000	4500	8900	5200
Cylinders, (60" stroke)	46, 86 in.	44, 88 in.	46, 86 in.	42, 86 in.	43 1/2, 2-75 1/2 in.
Piston rods, diam., in.	9, 10	8	9, 10	8, 10	9
Crank pins.....	14 × 14	18 × 18	14 × 14	20 × 18	22 & 16 × 14
Wrist pins.....	14 × 14	12 × 12	14 × 14	12 × 12	14 × 14
Shaft length.....	27 ft. 4 in.	25 ft. 3 in.	27 ft.	25 ft. 3 in.	35 ft.
max. diam.....	37 in.	37 in.	39 in.	37 in.	29 3/8 in.
bearings.....	34 × 60	34 × 60	34 × 60	34 × 60	26 × 60

The shafts are hollow, with a 16-in. hole, except the Edison which has 10 in. The speed of all the engines is 75 r.p.m., or 750 ft. per min. The crank-pins of the Manhattan and Rapid Transit engines each are attached to two connecting-rods, side by side, hor. and vert., each rod having a bearing 9 in. long on the pin. The crank-pins of the Edison engine are 16 in. diam. for the side-cranks, and 22 in. for the center-crank.

The four 8000-horse-power engines in the Manhattan station, new in 1902, were replaced in 1914-15, although still as good as new, by four 30,000 K.W. steam turbines occupying the same space. The turbines will have a water rate 30 per cent lower than the engines. (*Power*, April 27, 1915.)

**Some Large Rolling-Mill Engines.**

No.	Cylinders.	R.P.M.	Type.	Press. Lbs.	Fly-wheel.		Location.	Builders.
					Diam. Ft.	Wt. Lbs.		
1	44 & 82 × 60	65	Cross-C.	140	24	150,000	Republic I. & S. Co., Youngstown, Ohio.	Filer & Stowell.
2	46 & 80 × 60	80	Tandem.	150	24	110,000	Carnegie S. Co., Donora, Pa.	Wisconsin Eng. Co.
3	52 & 90 × 60	...	Tandem.	...	25	250,000	Carnegie S. Co., Youngstown, Ohio.	Wm. Tod Co.
4	2 each . . . . . 42 & 70 × 54	...	Double. Tandem.	150	none		Carnegie S. Co., S. Sharon, Pa.	Allis Chalmers Co.
5	2 each . . . . . 44 & 70 × 60	60	Double. Tandem.	150	none		{ Carnegie S. Co., Duquesne, Pa. Jones & Laughlin Steel Co., Aliquippa, Pa. }	Mackintosh, Hemp-hill & Co.

Some details: Main bearings, No. 1, 25 × 43 1/2 in.; No. 2, 30 × 52 in.; No. 3, 30 × 60 in. Shaft diam. at wheel pit, No. 1, 26 in.; No. 3, 36 in. Crank pins, No. 1, h.p. 14 × 14; l.p., 14 × 23 in.; No. 2, 18 × 18 in. Crosshead pins, No. 1, 12 × 14; No. 2, 16 × 20 in. No. 4 is a reversing engine, with the Marshall gear. No. 5 is a reversing engine with piston valves below the cylinders.

**Counterbalancing Engines.** — Prof. Unwin gives the formula for counterbalancing vertical engines:  $W_1 = W_2 r/p$ , . . . . . (1) in which  $W_1$  denotes the weight of the balance weight and  $p$  the radius to its center of gravity,  $W_2$  the weight of the crank-pin and half the weight of the connecting-rod, and  $r$  the length of the crank. For horizontal engines:

$$W_1 = 2/3 (W_2 + W_3) r/p \text{ to } 3/4 (W_2 + W_3) r/p, . . . . . (2)$$

In which  $W_3$  denotes the weight of the piston, piston-rod, cross-head, and the other half of the weight of the connecting-rod.

The *American Machinist*, commenting on these formulæ, says: For horizontal engines formula (2) is often used; formula (1) will give a counterbalance too light for vertical engines. We should use formula (2) for computing the counterbalance for both horizontal and vertical engines, excepting locomotives, in which the counterbalance should be heavier.

For an account of experiments on counterbalancing large engines, with a method of recording vibrations, see paper by D. S. Jacobus, *Trans. A. S. M. E.*, 1905.

**Preventing Vibrations of Engines.** — Many suggestions have been made for remedying the vibration and noise attendant on the working of the big engines which are employed to run dynamos. A plan which has given great satisfaction is to build hair-felt into the foundations of the engine. An electric company has had a 90-horse-power engine removed from its foundations, which were then taken up to the depth of 4 feet. A

layer of felt 5 inches thick was then placed on the foundations and run up 2 feet on all sides, and on the top of this the brickwork was built up. — *Safety Valve.*

**Steam-engine Foundations Embedded in Air.** — In the sugar-refinery of Claus Spreckels, at Philadelphia, Pa., the engines are distributed practically all over the buildings, a large proportion of them being on upper floors. Some are bolted to iron beams or girders, and are consequently innocent of all foundation. Some of these engines ran noiselessly and satisfactorily, while others produced more or less vibration and rattle. To correct the latter the engineers suspended foundations from the bottoms of the engines, so that, in looking at them from the lower floors, they were literally hanging in the air. — *Iron Age*, Mar. 13, 1890.

### COMMERCIAL ECONOMY. — COSTS OF POWER.

**The Cost of Steam Power** is an exceedingly variable quantity. The principal items to be considered in estimating total annual cost are: load factor; hours run per year; percentage of full load at different hours of the day; cost and quality of fuel; boiler efficiency and steam consumption of engines at different loads; cost of water and other supplies; cost of labor, first cost of plant, depreciation, repairs, interest, insurance and taxes.

In figuring depreciation not only should the probable life of the several parts of the plant, such as buildings, boilers, engines, condensers, etc., be considered, but also the possibility of part of the plant, or the whole of it, depreciating rapidly in value on account of obsolescence of the machinery or of changes in the conditions of the business.

When all of the heat in the exhaust steam from engines and pumps, including water of condensation, is used for heating purposes the fuel cost of steam-engine power may be practically nothing, since the exhaust contains all of the heat in the steam delivered to the engine except from 5 to 10 per cent which is converted into work, and a trifling amount lost by radiation.

**Most Economical Point of Cut-off in Steam-engines.** (See paper by Wolff and Denton, *Trans. A. S. M. E.*, vol. ii, p. 147-281; also, *Ratio of Expansion at Maximum Efficiency*, R. H. Thurston, vol. ii, p. 128.)

—The problem of the best ratio of expansion is not one of economy of consumption of fuel and economy of cost of boiler alone. The question of interest on cost of engine, depreciation of value of engine, repairs of engine, etc., enters as well; for as we increase the rate of expansion, and thus, within certain limits fixed by the back-pressure and condensation of steam, decrease the amount of fuel required and cost of boiler per unit of work, we have to increase the dimensions of the cylinder and the size of the engine, to attain the required power.

**Type of Engine to be used where Exhaust-steam is needed for Heating.** — In many factories more or less of the steam exhausted from the engines is utilized for boiling, drying, heating, etc. Where all the exhaust-steam is so used the question of economical use of steam in the engine itself is eliminated, and the high-pressure simple engine is entirely suitable. Where only part of the exhaust-steam is used, and the quantity so used varies at different times, the question of adopting a simple, a condensing, or a compound engine becomes more complex. This problem is treated by C. T. Main in *Trans. A. S. M. E.*, vol. x, p. 48. He shows that the ratios of the volumes of the cylinders in compound engines should vary according to the amount of exhaust-steam that can be used for heating. A case is given in which three different pressures of steam are required or could be used, as in a worsted dye-house: the high or boiler pressure for the engine, an intermediate pressure for crabbing, and low-pressure for boiling, drying, etc. If it did not make too much complication of parts in the engine, the boiler-pressure might be used in the high-pressure cylinder, exhausting into a receiver from which steam could be taken for running small engines and crabbing, the steam remaining in the receiver passing into the intermediate cylinder and expanded there to from 5 to 10 lbs. above the atmosphere and exhausted into a second receiver. From this receiver is drawn the low-pressure steam needed for drying, boiling, warming mills, etc., the steam remaining in the receiver passing into the condensing cylinder.

**Cost of Steam-power.** (Chas. T. Main, *Trans. A. S. M. E.*, x, 48.) — Estimated costs in New England in 1888, per horse-power, using com-



pound condensing, and non-condensing engines, and based on engines of 1000 H.P. are as follows:

	Compound Engine.	Condensing Engine.	Non-condensing Engine.
1. Cost engine and piping, complete....	\$25.00	\$20.00	\$17.50
2. Engine-house.....	8.00	7.50	7.50
3. Engine foundations.....	7.00	5.50	4.50
4. Total engine plant.....	40.00	33.00	29.50
5. Depreciation, 4% on total cost.....	1.60	1.32	1.18
6. Repairs, 2% on total cost.....	0.80	0.66	0.59
7. Interest, 5% on total cost.....	2.00	1.65	1.475
8. Taxation, 1.5% on 3/4 cost.....	0.45	0.371	0.332
9. Insurance on engine and house.....	0.165	0.138	0.125
10. Total of lines 5, 6, 7, 8, 9.....	5.015	4.139	3.702
11. Cost boilers, feed-pumps, etc.....	9.33	13.33	16.00
12. Boiler-house.....	2.92	4.17	5.00
13. Chimney and flues.....	6.11	7.30	8.00
14. Total boiler-plant.....	18.36	24.80	29.00
15. Depreciation, 5% on total cost.....	0.918	1.240	1.450
16. Repairs, 2% on total cost.....	0.367	0.496	0.580
17. Interest, 5% on total cost.....	0.918	1.240	1.450
18. Taxation, 1.5% on 3/4 cost.....	0.207	0.279	0.326
19. Insurance, 0.5% on total cost.....	0.092	0.124	0.145
20. Total of lines 15 to 19.....	2.502	3.379	3.951
21. Coal used per I.H.P. per hour, lbs. . .	1.75	2.50	3.00
22. Cost of coal per I.H.P. per day of 10 1/4 hours at \$5.00 per ton of 2240 lbs. . .	4.00	5.72	6.86
23. Attendance of engine per day.....	0.60	0.40	0.35
24. Attendance of boilers per day.....	0.53	0.75	0.90
25. Oil, waste, and supplies, per day....	0.25	0.22	0.20
26. Total daily expense.....	5.38	7.09	8.31
27. Yearly running expense, 308 days, per I.H.P.....	\$16.570	\$21.837	\$25.595
28. Total yearly expense, lines 10, 20, and 27.....	24.087	29.355	33.248
29. Total yearly expense per I.H.P. for power if 50% of exhaust-steam is used for heating.....	12.597	14.907	16.663
30. Total if all exhaust-steam is used for heating.....	8.624	7.916	7.700

When exhaust-steam or a part of the receiver-steam is used for heating, or if part of the steam in a condensing engine is diverted from the condenser, and used for other purposes than power, the value of such steam should be deducted from the cost of the total amount of steam generated in order to arrive at the cost properly chargeable to power. The figures in lines 29 and 30 are based on an assumption made by Mr. Main of losses of heat amounting to 25% between the boiler and the exhaust-pipe, an allowance which is probably too large.

See also two papers by Chas. E. Emery on "Cost of Steam Power," *Trans. A. S. M. E.*, vol. xii, Nov., 1883, and *Trans. A. I. E. E.*, vol. x, Mar., 1893.

**Cost of Coal for Steam-power.**—The following table shows the amount and the cost of coal per day and per year for various horse-powers from 1 to 1000, based on the assumption of 4 lbs. of coal being used per

hour per horse-power. It is useful, among other things, in estimating the saving that may be made in fuel by substituting more economical boilers and engines for those already in use. Thus with coal at \$3.00 per ton of 2000 lbs., a saving of \$9000 per year in fuel may be made by replacing a steam plant of 1000 H.P., requiring 4 lbs. of coal per hour per horse-power, with one requiring only 2 lbs.

Horse-power.	Coal Consumption, at 4 lbs. per H.P. hour; 10 hours a day; 300 days per Year.					\$2 per Short Ton.		\$3 per Short Ton.		\$4 per Short Ton.	
	Lbs.	Long Tons.		Short Tons.		Cost in Dollars.		Cost in Dollars.		Cost in Dollars.	
		Per Day.	Per Day.	Per Year.	Per Day.	Per Yr.	Day.	Yr.	Day.	Yr.	Day.
	1	40	0.0179	53.57	0.02	6	0.04	12	0.06	18	0.08
10	400	0.1786	53.57	0.20	60	0.40	120	0.60	180	0.80	240
25	1,000	0.4464	133.92	0.50	150	1.00	300	1.50	450	2.00	600
50	2,000	0.8928	267.85	1.00	300	2.00	600	3.00	900	4.00	1,200
75	3,000	1.3393	401.78	1.50	450	3.00	900	4.50	1,350	6.00	1,800
100	4,000	1.7857	535.71	2.00	600	4.00	1,200	6.00	1,800	8.00	2,400
150	6,000	2.6785	803.56	3.00	900	6.00	1,800	9.00	2,700	12.00	3,600
200	8,000	3.5714	1,071.42	4.00	1,200	8.00	2,400	12.00	3,600	16.00	4,800
250	10,000	4.4642	1,339.27	5.00	1,500	10.00	3,000	15.00	4,500	20.00	6,000
300	12,000	5.3571	1,607.13	6.00	1,800	12.00	3,600	18.00	5,400	24.00	7,200
350	14,000	6.2500	1,874.98	7.00	2,100	14.00	4,200	21.00	6,200	28.00	8,400
400	16,000	7.1428	2,142.84	8.00	2,400	16.00	4,800	24.00	7,200	32.00	9,600
450	18,000	8.0356	2,410.69	9.00	2,700	18.00	5,400	27.00	8,100	36.00	10,800
500	20,000	8.9285	2,678.55	10.00	3,000	20.00	6,000	30.00	9,000	40.00	12,000
600	24,000	10.7142	3,214.26	12.00	3,600	24.00	7,200	36.00	10,800	48.00	14,400
700	28,000	12.4999	3,749.97	14.00	4,200	28.00	8,400	42.00	11,600	56.00	16,800
800	32,000	14.2856	4,285.68	16.00	4,800	32.00	9,600	48.00	12,400	64.00	19,200
900	36,000	16.0713	4,821.39	18.00	5,400	36.00	10,800	54.00	14,200	72.00	21,600
1000	40,000	17.8570	5,357.10	20.00	6,000	40.00	12,000	60.00	18,000	80.00	24,000

It is usual to consider that a factory working 10 hours a day requires 10½ hours coal consumption on account of the coal used in banking or in starting the fires, and that there are 306 working days in the year. For these conditions multiply the costs given in the table by 1.071. For 24 hours a day 365 days in the year, multiply them by 2.68. For other rates of coal consumption than 4 lbs. per H.P. hour, the figures are to be modified proportionately.

**Relative Cost of Different Sizes of Steam-engines.**

(From catalogue of the Buckeye Engine Co., Part III.)

Horse-power....	50	75	100	125	150	200	250	300	350	400	500	600	700	800
Cost per H.P., \$	20	17½	16	15	14½	13½	13	12¾	12.5	12.6	12.8	13¼	14	15

**Power Plant Economics.** (H. G. Stott, *Trans. A. I. E. E.*, 1906.)—The table on the following page gives an analysis of the heat losses found in a year's operation of one of the most efficient plants in existence.

The following notes concerning power-plant economy are condensed from Mr. Stott's paper.

Item 1. B.T.U. per lb. of coal. The coal is bought and paid for on the basis of the B.T.U. found by a bomb calorimeter.

## AVERAGE LOSSES IN THE CONVERSION OF 1 LB. OF COAL INTO ELECTRICITY.

	B.T.U.	%	B.T.U.	%
1. B.T.U. per lb. of coal supplied . . . . .	14,150	100.0		
2. Loss in ashes . . . . .			340	2.4
3. Loss to stack . . . . .			3,212	22.7
4. Loss in boiler radiation and air leakage			1,131	8.0
5. Returned by feed-water heater . . . . .	441	3.1		
6. Returned by economizer . . . . .	960	6.8		
7. Loss in pipe radiation . . . . .			28	0.2
8. Delivered to circulator . . . . .			223	1.6
9. Delivered to feed pump . . . . .			203	1.4
10. Loss in leakage and high-pressure drips			152	1.1
11. Delivered to small auxiliaries . . . . .			51	0.4
12. Heating . . . . .			31	0.2
13. Loss in engine friction . . . . .			111	0.8
14. Electrical losses . . . . .			36	0.3
15. Engine radiation losses . . . . .			28	0.2
16. Rejected to condenser . . . . .			8,524	60.1
17. To house auxiliaries . . . . .			29	0.2
	15,551	109.9	14,099	99.6
	14,099	99.6		
Delivered to bus bar	1,452	10.3		

Item 3. The chimney loss is very large, due to admitting too much air to the combustion chamber. This loss can be reduced about half by the use of a CO<sub>2</sub> recorder and proper management of the fire.

Item 4. This loss is largely due to infiltration of air into the brick setting. It can be saved by having an air-tight sheet-iron casing enclosing a magnesia lining outside of the brickwork.

Item 5. All auxiliaries should be driven by steam, so that their exhaust may be utilized in the feed-water heater.

Item 6. In all cases where the load factor exceeds 25% the investment in economizers will be justified.

Item 7. The pipes are covered with two layers of covering, each about 1.5 in. thick.

Item 10. The high-pressure drips can be returned to the boiler, so practically all the loss under this heading is recoverable.

Item 13. Recent tests of a 7500-H.P. reciprocating engine show a mechanical efficiency of 93.65%, or an engine friction of 6.35%. The engine is lubricated by the flushing system.

Item 16. The maximum theoretical efficiency of an engine working between 175 lbs. gauge and 28 ins. vacuum is

$$(T_1 - T_2) \div T_1 = (837 - 560) \div 837 = 33\%.$$

The actual best efficiency of this engine is 17 lbs. per K.W.-hour = 16.7% thermal efficiency; dividing by 0.98, the generator efficiency, gives the net thermodynamic efficiency of the engine, = 17%. The difference between the theoretical and the actual efficiency is 33 - 17 = 16%, of which 6.35% is due to engine friction, and the balance, 9.65%; is due to cylinder condensation, incomplete expansion, and radiation. [Some of this difference is due to the fact that the engine does not work on the Carnot cycle, in which the heat is all received at the highest temperature, and part of this loss might be saved by the Nordberg feed-water heating system. There may also be a slight loss from leakage. W.K.] Superheated steam, to such an extent as to insure dry steam at the point of cut-off in the low-pressure cylinder, might save 5 or 6%.

The present type of power plant using reciprocating engines can be improved in efficiency as follows: Reduction of stack losses, 12%; boiler radiation and leakage, 5%; by superheating, 6%; resulting in a net increase of thermal efficiency of the entire plant of 4.14% and bringing the total from 10.3 to 14.44%.

*The Steam Turbine.* — The best results from the steam turbine up to date show that its economy on dry saturated steam is practically equal to that of the reciprocating engine, and that 200° superheat reduces its steam consumption 13.5%. The shape of the economy curve is much



**Maintenance and Operation Costs of Different Types of Plant.**

	Recip- rocating Engines.	Steam Turbines	Recip- rocating Engines and Steam Turbines.	Gas- Engine Plant.	Gas Engines and Steam Turbines.
<b>MAINTENANCE.</b>					
1. Engine room mechanical.....	2.57	0.51	1.54	2.57	1.54
2. Boiler room or producer room.....	4.61	4.30	3.52	1.15	1.95
3. Coal- and ash-handling apparatus...	0.58	0.54	0.44	0.29	0.29
4. Electrical apparatus	1.12	1.12	1.12	1.12	1.12
<b>OPERATION.</b>					
5. Coal- and ash-handling labor.....	2.26	2.11	1.74	1.13	1.13
6. Removal of ashes....	1.06	0.94	0.80	0.53	0.53
7. Dock rental.....	0.74	0.74	0.74	0.74	0.74
8. Boiler-room labor....	7.15	6.68	5.46	1.79	3.03
9. Boiler-room oil, waste, etc. ....	0.17	0.17	0.17	0.17	0.17
10. Coal.....	61.30	57.30	46.87	26.31	25.77
11. Water.....	7.14	0.71	5.46	3.57	2.14
12. Engine-room mechanical labor....	6.71	1.35	4.03	6.71	4.03
13. Lubrication.....	1.77	0.35	1.01	1.77	1.06
14. Waste, etc.....	0.30	0.30	0.30	0.30	0.30
15. Electrical labor.....	2.52	2.52	2.52	2.52	2.52
Relative cost of maintenance and operation ..	100.00	79.64	75.72	50.67	46.32
Relative investment in per cent.....	100.00	82.50	77.00	100.00	91.20

flatter [from 3300 to 8000 K.W. the range of steam consumption is between 14.6 and 15.0 lbs. per K.W.-hour], so that the all-day efficiency would be considerably better than that of the reciprocating engine, and the cost would be about 33% less for the combined steam motor and electric generator.

*High-pressure Reciprocating Engine with Low-pressure Turbine.*—The reciprocating engine is more efficient than the turbine in the higher pressures, while the turbine can expand to lower pressures and utilize the gain of full expansion. The combination of the two would therefore be more efficient than a turbine alone.

*The Gas Engine.*—The best result up to date obtained from gas producers and gas engines is about as follows: Loss in producer and auxiliaries, 20%; in jacket water, 19%; in exhaust gases, 30%; in engine friction, 6.5%; in electric generator, 0.5%. Total losses, 76%. Converted into electric energy, 24%. Only one important objection can be raised to this motor, that its range of economical load is practically limited to between 50% and full load. This lack of overload capacity is probably a fatal defect for the ordinary railway power plant acting under a violently fluctuating load, unless protected by a large storage-battery.

At light loads the economy of gas and liquid fuel engines fell off even more rapidly than in steam-engines. The engine friction was large and nearly constant, and in some cases the combustion was also less perfect at light loads. At the Dresden Central Station the gas-engines were kept working at nearly their full power by the use of storage-batteries. The results of some experiments are given below:

Brake-load, per cent of full Power.	Gas-engine, cu. ft. of Gas per Brake H.P. per hour.	Petroleum Eng., Lbs. of Oil per B.H.P. per hr.	Petroleum Eng., Lbs. of Oil per B.H.P. per hr.
100	22.2	0.96	0.88
75	23.8	1.11	0.99
59	28.0	1.44	1.20
20	40.8	2.38	1.82
12½	66.3	4.25	3.07

*Combination of Gas Engines and Turbines.* — A steam turbine unit can be designed to take care of 100% overload for a few seconds. If a plant were designed with 50% of its normal capacity in gas engines and 50% in steam turbines, any fluctuations in load likely to arise in practice could be taken care of. By utilizing the waste heat of the gas engine in economizers and superheaters there can be saved approximately 37% of this waste heat, to make steam for the turbines. The average total thermal efficiency of such a combination plant would be 24.5%. This combination offers the possibility of producing the kilowatt-hour for less than one-half its present cost.

The table on p. 1013 shows the distribution of estimated relative maintenance and operation costs of five different types of plant, the total cost of current with the reciprocating engine plant being taken at 100.

*Storing Heat in Hot Water.* — (See also p. 927.) There is no satisfactory method for equalizing the load on the engines and boilers in electric-light stations. Storage-batteries have been used, but they are expensive in first cost, repairs, and attention. Mr. Halpin, of London, proposes to store heat during the day in specially constructed reservoirs. As the water in the boilers is raised to 250 lbs. pressure, it is conducted to cylindrical reservoirs resembling English horizontal boilers, and stored there for use when wanted. In this way a comparatively small boiler-plant can be used for heating the water to 250 lbs. pressure all through the twenty-four hours of the day, and the stored water may be drawn on at any time, according to the magnitude of the demand. The steam-engines are to be worked by the steam generated by the release of pressure from this water, and the valves are to be arranged in such a way that the steam shall work at 130 lbs. pressure. A reservoir 8 ft. in diameter and 30 ft. long, containing 84,000 lbs. of heated water at 250 lbs. pressure, would supply 5250 lbs. of steam at 130 lbs. pressure. As the steam consumption of a condensing electric-light engine is about 18 lbs. per horse-power hour, such a reservoir would supply 286 effective horse-power hours. In 1878, in France, this method of storing steam was used on a tramway. M. Francq, the engineer, designed a smokeless locomotive to work by steam-power supplied by a reservoir containing 400 gallons of water at 220 lbs. pressure. The reservoir was charged with steam from a stationary boiler at one end of the tramway.

An installation of the Rateau low-pressure turbine and regenerator system at the rolling mill of the International Harvester Co., in Chicago, is described in *Power*, June, 1907. The regenerator is a cylindrical shell 11½ ft. diam., 30 ft. long, containing six large elliptical tubes perforated with many ¾-in. holes through which exhaust steam from a reversing blooming-mill engine enters the water contained in the shell. A large steam pipe leads from the shell to the turbine. A series of tests of the combination was made, giving results as follows: The 42 × 60 in. blooming mill engine developed 820 I.H.P. on the average, with a water rate of 64 lbs. per I.H.P. hour. It delivered its exhaust, averaging a little above atmospheric pressure, to the regenerator, at an irregular rate corresponding to the varying work of the rolling-mill engine. The regenerator furnished steam to the turbine, which in four different tests developed 444, 544, 727 and 869 brake H.P. at the turbine shaft, with a steam consumption of 47.7, 37.1, 30.7 and 33.7 lbs. of steam per B.H.P. hour at the turbine. Had the turbine been of sufficient capacity to use all the exhaust of the mill engine, 1510 H.P. might have been delivered at the switchboard, which added to the 820 of the mill engine would make 2330 H.P. for 52,400 lbs. of steam, or a steam rate of 22.5 lbs. per H.P. hour for the combination.

**UTILIZING THE SUN'S HEAT AS A SOURCE OF POWER.**

John Ericsson, 1868-1875, experimented on "solar engines," in which reflecting surfaces concentrated the sun's rays at a central point causing them to boil water. A large motor of this type was built at Pasadena, Cal., in 1898. The rays were concentrated upon a water heater through which ether or sulphur dioxide was pumped in pipes, and utilized in a vapor engine. The apparatus was commercially unsuccessful on account of variable weather conditions. *Eng. News*, May 13, 1909, describes the solar heat systems of F. Shuman and of H. E. Willsie and John Boyle, Jr.

In the Shuman invention a tract of land is rolled level, forming a shallow trough. This is lined with asphaltum pitch and covered with about 3 ins. of water. Over the water about  $\frac{1}{16}$  in. of paraffine is flowed, leaving between this and a glass cover about 6 ins. of dead air space. It is estimated that a power plant of this type to cover a heat-absorption area of 160,000 sq. ft., or nearly four acres, would develop about 1000 H.P. Provision is made for storing hot water in excess of the requirements of a low-pressure turbine during the day, to be utilized for running the turbine during the period when there is no absorption of heat. The heated water is run from the heat absorber to the storage tank, thence to the turbine, through a condenser and back to the heat absorber. The water enters the thermally insulated storage tank, or the turbine, at about 202° F. With a vacuum of 28 ins. in the condenser, the boiling-point of the water is reduced to 102°, and as it enters the turbine nearly 10% explodes into steam. Mr. Shuman estimates that a 1000-H.P. plant built upon his plan would cost about \$40,000.

The Willsie and Boyle plant also utilizes the indirect system of absorbing solar heat and storing the hot water in tanks. This hot water circulates in a boiler containing some volatile liquid, and the vapor generated is used to operate the engine, is condensed, and returned to the boiler to be used again. Mr. Willsie compares the cost per H.P.-hour in a 400-H.P. steam-electric and solar-electric power plant, and finds that the steam plant would have to obtain its coal for \$0.66 a ton to compete with the sun power plant in districts favorable to the latter.

**RULES FOR CONDUCTING TESTS FOR RECIPROCATING STEAM-ENGINES.**

(Abstract of the 1915 Code of the Power Test Committee of the Am. Soc. M. E.)

The code for steam engine tests applies to tests for determining the performance of the engine alone (including reheaters and jackets, if any) apart from that of steam-driven auxiliaries which are necessary to its operation. For tests of engine and auxiliaries combined, and tests of multiple expansion engines from which steam is withdrawn for heating feed water or otherwise, refer to the Code for Complete Steam Power Plants.

**OBJECT AND PREPARATIONS.**

Determine the object of the test, take the dimensions, and note the physical conditions, not only of the engine, but of all parts of the plant that are concerned in the determinations, examine for leakages, install the testing appliances, etc., and prepare for the test accordingly.

The determination of the heat and steam consumption of an engine by feed-water test requires the measurement of the various supplies of water fed to the boiler; that of the water wasted by separators and drips on the main steam line, that of steam used for other purposes than the main engine cylinders, and that of water and steam which escape by leakage of the boiler and piping; all of these last being deducted from the total feed water measured.

Where a surface condenser is provided and the steam consumption is determined from the water discharged by the air pump, no such measurement of drips and leakage is required, but assurance must be had that all the steam passing into the cylinders finds its way



into the condenser. If the condenser leaks, the defects causing such leakage should be remedied, or suitable correction should be made.

When no other method is available the steam consumption may be determined by the use of a steam meter, bearing in mind the caution that it should be calibrated under the exact conditions of use.

The steam consumed by steam-driven auxiliaries which are required for the operation of the engine should be included in the total steam from which the heat consumption is calculated and the quantity of steam thus used should be determined and reported.

#### OPERATING CONDITIONS.

Determine what the operating conditions should be to conform to the object in view, and see that they prevail throughout the trial.

#### DURATION.

A test for steam or heat consumption, with substantially constant load, should be continued for such time as may be necessary to obtain a number of successive hourly records, during which the results are reasonably uniform. For a test involving the measurement of feed-water for this purpose, five hours' duration is sufficient. Where a surface condenser is used, and the measurement is that of the water discharged by the air pump, the duration may be somewhat shorter. In this case, successive half-hourly records may be compared and the time correspondingly reduced.

When the load varies widely at different times of the day, the duration should be such as to cover the entire period of variation.

#### STARTING AND STOPPING.

The engine and appurtenances having been set to work and thoroughly heated under the prescribed conditions of test (except in cases where the object is to obtain the performance under working conditions) note the water levels in the boilers and feed reservoir, take the time and consider this the starting time. Then begin the measurements and observations and carry them forward until the end of the period determined on. When this time arrives, the water levels and steam pressure should be brought as near as practicable to the same points as at the start. This being done, again note the time and consider it the stopping time of the test. If there are differences in the water levels, proper corrections are to be applied.

Where a surface condenser is used, the collection of water discharged by the air pump begins at the starting time, and the water is thereafter measured or weighed until the end of the test.

#### RECORDS.

Half-hourly readings of the instruments are sufficient, excepting where there are wide fluctuations. A set of indicator diagrams should be obtained at intervals of 15 or 20 minutes, and oftener if the nature of the test makes it necessary. Mark on each card the cylinder and the end on which it was taken, also the time of day. Record on one card of each set the readings of the steam pressure and vacuum gages. These records should be subsequently entered on the general log, together with the areas, pressures, lengths, etc., measured from the diagrams, when these are worked up.

#### CALCULATION OF RESULTS.

*Dry Steam.*—The quantity of dry steam consumed is determined by deducting the moisture, if any, found by the calorimeter test from the total amount of feed-water (the latter being corrected for leakages and other losses) or from the amount of air-pump discharge, as the case may be. If the steam is superheated, no correction is to be made for the superheat.

*Heat Consumption.*—The number of heat-units consumed by the engine is found by multiplying the weight of feed-water consumed,

corrected for moisture in the steam, if any, and for plant leakages and other exterior losses, by the total heat of 1 lb. of steam (saturated or superheated) less the heat in 1 lb. of water at the temperature corresponding to the pressure in the exhaust pipe near the engine.

*Indicated Horse-power.*—In a single double-acting cylinder the indicated horse-power is found by using the formula

$$\frac{PLAN}{33,000}$$

in which  $P$  represents the average mean effective pressure in pounds per square inch measured from the indicator diagrams,  $L$  the length of stroke in feet,  $A$  the area of the piston less one-half the area of the piston rod, or the mean area of the rod if it passes through both cylinder heads, in square inches, and  $N$  the number of single strokes per minute.

*Brake Horse-power.*—The brake horse-power is found by multiplying the net pressure or weight in pounds on the brake arm (the gross weight minus the weight when the brake is entirely free from the pulley) in pounds, the circumference of the circle whose radius is the horizontal distance between the center of the shaft and the bearing point at the end of the brake arm in feet, and the number of revolutions of the brake shaft per minute; and dividing the product by 33,000.

*Electrical Horse-power.*—The electrical horse-power of a direct-connected generator is found by dividing the output at the terminals expressed in kilowatts, by the decimal 0.7457. With alternating current generators the net output is to be used, this being the total output less that consumed for excitation and for separately-driven ventilating fans.

*Efficiency.*—The thermal efficiency, that is, the percentage of the total heat consumption which is converted into work, is found by dividing the quantity 2546.5, which is the B.T.U. equivalent of one H.P.-hour, by the number of heat-units actually consumed per H.P.-hour.

The Rankine cycle efficiency is found by dividing the heat consumption of an ideal engine conforming to the Rankine cycle by the actual heat consumption.

*Steam Accounted for by Indicator Diagrams at Points Near Cut-off and Release.*—The steam accounted for, expressed in pounds per I.H.P. per hour, may be found by using the formula

$$\frac{13,750}{\text{M.E.P.}}[(C + E)W_c - (H + E)W_h],$$

in which

M.E.P. = mean effective pressure;

$C$  = proportion of direct stroke completed at points on expansion line near cut-off or release;

$E$  = proportion of clearance;

$H$  = proportion of return stroke uncompleted at point on compression line just after exhaust closure;

$W_c$  = weight of 1 cu. ft. steam at pressure shown at cut-off or release point;

$W_h$  = weight of 1 cu. ft. steam at pressure shown at compression point.

In multiple expansion engines the mean effective pressure to be used in the above formula is the aggregate M.E.P. referred to the cylinder under consideration. In a compound engine the aggregate M.E.P. for the h.p. cylinder is the sum of the actual M.E.P. of the h.p. cylinder and that of l.p. cylinder multiplied by the cylinder ratio. Likewise the aggregate M.E.P. for the l.p. cylinder is the sum of the actual M.E.P. of the l.p. cylinder and the M.E.P. of the h.p. cylinder divided by the cylinder ratio.

The relation between the weight of steam shown by the indicator at any point in the expansion line and the weight of the mixture of steam and water in the cylinder, may be represented graphically by plotting on the diagram a saturated steam curve showing the

total consumption per stroke (including steam retained at compression) and comparing the abscissæ of this curve with the abscissæ of the expansion line, both measured from the line of no clearance.

*Cut-off and Ratio of Expansion.*—To find the percentage of cut-off, or what may best be termed the "commercial cut-off," the following rule should be observed:

Through the point of maximum pressure during admission draw a line parallel to the atmospheric line. Through a point on the expansion line where the cut-off is complete, draw a hyperbolic curve. The intersection of these two lines is the point of commercial cut-off, and the proportion of cut-off is found by dividing the length measured on the diagram up to this point by the total length.

To find the ratio of expansion divide the volume corresponding to the piston displacement, including clearance, by the volume of the steam at the commercial cut-off, including clearance.

In a multiple expansion engine the ratio of expansion is found by dividing the volume of the l.p. cylinder, including clearance, by the volume of the h.p. cylinder at the commercial cut-off, including clearance.

#### DATA AND RESULTS.

The data and results should be reported in accordance with the form given herewith, adding lines for data not provided for, or omitting those not required, as may conform to the object in view. If the principal data and results pertaining to steam consumption only are desired, the subjoined abbreviated table may be used.

#### DATA AND RESULTS OF STEAM-ENGINE TEST

Code of 1915.

1. Test of . . . . . engine located at . . . . .  
     To determine . . . . .  
     Test conducted by . . . . .

#### DIMENSIONS, ETC.

2. Type of engine (simple or multiple expansion) . . . . .
  3. Class of service (mill, marine, electric, etc.) . . . . .
  4. Auxiliaries (steam or electric driven) . . . . .
  5. Rated power of engine . . . . .
- |  | 1st   | 2d    | 3d    |
|--|-------|-------|-------|
| 6. Diameter of cylinders . . . . . in.   | ..... | ..... | ..... |
| 7. Stroke of pistons . . . . . ft.   | ..... | ..... | ..... |
| (a) Diameter of piston-rod, each end,<br>in . . . . .                                    | ..... | ..... | ..... |
| 8. Clearance (average) in per cent of piston<br>displacement . . . . . 1 to —            | ..... | ..... | ..... |
| 9. H. P. constant 1 lb. 1 rev. . . . . H.P.  | ..... | ..... | ..... |
| (a) Cylinder ratio (based on net piston<br>displacement) . . . . . 1 to —                | ..... | ..... | ..... |
| 10. Capacity of generator or other apparatus<br>consuming power of engine . . . . . H.P. | ..... | ..... | ..... |

#### DATE AND DURATION.

11. Date . . . . .
12. Duration . . . . . hr.

#### AVERAGE PRESSURES AND TEMPERATURES.

13. Pressure in steam pipe near throttle, by gage . . . . . lbs. per sq. in.
14. Barometric pressure . . . . . ins.
15. Pressure in 1st receiver, by gage . . . . . lbs. per sq. in.
16. Pressure in 2d receiver, by gage . . . . . lbs. per sq. in.
17. Vacuum in condenser . . . . . ins.
18. Pressure in jackets and reheaters . . . . . lbs. per sq. in.
19. Temperature of steam near throttle, if superheated . . . . . degs.
20. Temperature corresponding to pressure in exhaust pipe  
    near engine . . . . . degs.



QUALITY OF STEAM.

21. Percentage of moisture in steam near throttle, or degrees of superheating..... % or deg.

TOTAL QUANTITIES.

22. Water fed to boilers, from main supply..... lbs.  
 23. Water fed to boilers from additional supplies..... lbs.  
 24. Total water fed to boilers..... lbs.  
 25. Total condensed steam from surface condenser (corrected for condenser leakage)..... lbs.  
 26. Total dry steam consumed (Item 24 to 25 less moisture in steam)..... lbs.

HOURLY QUANTITIES.

27. Water fed to boilers from main supply per hour..... lbs.  
 28. Water fed to boilers from additional supplies per hour.. lbs.  
 29. Total water fed to boilers or drawn from surface condenser per hour..... lbs.  
 30. Total dry steam consumed for all purposes per hour (Item 26 ÷ Item 12)..... lbs.  
 31. Steam consumed per hour for all purposes foreign to the main engine (including drips and leakage of plant)... lbs.  
 32. Dry steam consumed by engine per hour (Item 30 - Item 31)..... lbs.  
 33. Heat units consumed by engine per hour (Item 32 × total heat of steam per lb. above exhaust temperature of Item 20)..... B.T.U.

INDICATOR DIAGRAMS.

- |     |   |          |         |         |
|-----|---|----------|---------|---------|
|     |   | 1st Cyl. | 2d Cyl. | 3d Cyl. |
| 34. | Commercial cut-off in per cent of stroke, per cent  | .....    | .....   | .....   |
| 35. | Initial pressure above atmosphere..... lbs. per sq. in.                                       | .....    | .....   | .....   |
| 36. | Back pressure at lowest point above or below atmosphere..... lbs. per sq. in.                 | .....    | .....   | .....   |
| 37. | Mean effective pressure..... lbs. per sq. in.   | .....    | .....   | .....   |
| 38. | Aggregate M.E.P. referred to each cylinder..... lbs. per sq. in.                              | .....    | .....   | .....   |
| 39. | Steam accounted for per I.H.P.-hr. at point on expansion line shortly after cut-off..... lbs. | .....    | .....   | .....   |
| 40. | Steam accounted for per I.H.P.-hr. at point on expansion line just before release..... lbs.   | .....    | .....   | .....   |

SPEED.

41. Revolutions per minute..... R.P.M.  
 42. Piston speed per minute..... ft.  
 (a) Variation of speed between no load and full load. per cent.  
 (b) Momentary fluctuation of speed on suddenly changing from full load to half load..... per cent.

POWER.

43. Indicated H.P. developed, whole engine..... I.H.P.  
 (a) I.H.P. developed by 1st cylinder..... I.H.P.  
 (b) I.H.P. developed by 2d cylinder..... I.H.P.  
 (c) I.H.P. developed by 3d cylinder..... I.H.P.  
 44. Brake H.P..... B.H.P.  
 45. Friction of engine (Item 43 - Item 44)..... H.P.  
 (a) Friction expressed in percentage of I.H.P. (Item 45 ÷ Item 43 × 100)..... per cent.  
 (b) Indicated H.P. with no load, at normal speed.... I.H.P.

## ECONOMY RESULTS.

46. Dry steam consumed by engine per I.H.P. per hr. . . . .	lbs.
47. Dry steam consumed by engine per brake H.P.-hr. . . . .	lbs.
48. Percentage of steam consumed by engine accounted for by indicator at point near cut-off. . . . .	per cent.
49. Percentage of steam consumed near release. . . . .	per cent.
50. Heat-units consumed by engine per I.H.P.-hr. (Item 33 ÷ Item 43). . . . .	B.T.U.
51. Heat-units consumed by engine per brake H.P.-hr. (Item 33 ÷ Item 44). . . . .	B.T.U.
52. Heat-units consumed per H.P.-hr. by ideal engine, based on Rankine cycle. . . . .	B.T.U.

## EFFICIENCY RESULTS.

53. Thermal efficiency of engine referred to I.H.P. (2546.5 ÷ Item 50). . . . .	per cent.
54. Thermal efficiency of engine referred to Brake H.P. (2546.5 ÷ Item 51). . . . .	per cent.
55. Efficiency of engine based on Rankine cycle referred to I.H.P. (Item 52 ÷ Item 50). . . . .	per cent.
56. Efficiency of engine referred to Brake H.P. (Item 52 ÷ Item 51). . . . .	per cent.

## WORK DONE PER HEAT-UNIT.

57. Foot-pounds of net work per B.T.U. consumed by engine (1,980,000 ÷ Item 51). . . . .	ft.-lbs.
---	----------

## SAMPLE DIAGRAMS.

58. Sample diagrams from each cylinder . . . . .

NOTE:—For an engine driving an electric generator the form should be enlarged to include the electrical data, embracing the average voltage, number of amperes each phase, number of watts, number of watt-hours, average power factor, etc.; and the economy results based on the electric output embracing the heat-units and steam consumed per electric H.P. per hour and per kw.-hr., together with the efficiency of the generator.

Likewise, in a marine engine having a shaft dynamometer, the form should include the data obtained from this instrument, in which case the Brake H.P. becomes the Shaft H.P.

## PRINCIPAL DATA AND RESULTS OF RECIPROCATING ENGINE TEST.

1. Dimensions of cylinders. . . . .	
2. Date. . . . .	
3. Duration. . . . .	hrs.
4. Pressure in steam pipe near throttle by gage. . . . .	lbs. per sq. in.
5. Pressure in receivers. . . . .	lbs. per sq. in.
6. Vacuum in condenser. . . . .	ins.
7. Percentage of moisture in steam near throttle or number of degrees of superheating. . . . .	% or deg.
8. Net steam consumed per hour. . . . .	lbs.
9. Mean effective pressure in each cylinder. . . . .	lbs. per sq. in.
10. Revolutions per minute. . . . .	R.P.M.
11. Indicated horse-power developed. . . . .	H.P.
12. Steam consumed per I.H.P. per hr. . . . .	lbs.
13. Steam accounted for at cut-off each cylinder. . . . .	lbs.
14. Heat consumed per I.H.P. per hr. . . . .	B.T.U.

**DIMENSIONS OF PARTS OF ENGINES.**

The treatment of this subject by the leading authorities on the steam-engine is very unsatisfactory, being a confused mass of rules and formulæ based partly upon theory and partly upon practice. The practice of builders shows an exceeding diversity of opinion as to correct dimensions. The treatment given below is chiefly the result of a study of the works of Rankine, Seaton, Unwin, Thurston, Marks, and Whitham, and is largely a condensation of a series of articles by the author published in the *American Machinist*, in 1894, with many alterations and much additional matter.

(Two notable papers on the subject, however, have appeared: 1, Current Practice in Engine Proportions, by Prof. John H. Barr, 1897; and 2, Current Practice in Steam-engine Design, by Ole N. Trooien, 1909. Both of these are abstracted on pages 1039 and 1040.)

**Cylinder.** (Whitham)—Length of bore = stroke + breadth of piston-ring -  $\frac{1}{8}$  to  $\frac{1}{2}$  in.; length between heads = stroke + thickness of piston + sum of clearances at both ends; thickness of piston = breadth of ring + thickness of flange on one side to carry the ring + thickness of follower-plate.

Thickness of flange or follower...  $\frac{3}{8}$  to  $\frac{1}{2}$  in.  $\frac{3}{4}$  in. 1 in.  
 For cylinder of diameter..... 8 to 10 in. 36 in. 60 to 100 in.

**Clearance of Piston.** (Seaton.)—The clearance allowed varies with the size of the engine from  $\frac{1}{8}$  to  $\frac{3}{8}$  in. for roughness of castings and  $\frac{1}{16}$  to  $\frac{1}{8}$  in. for each working joint. Naval and other very fast-running engines have a larger allowance. In a vertical direct-acting engine the parts which wear so as to bring the piston nearer the bottom are three, viz., the shaft journals, the crank-pin brasses, and piston-rod gudgeon-brasses.

**Thickness of Cylinder.**—In the earlier editions of this book eleven formulæ, from seven different authorities, were given for thickness of cylinders and they were applied to six engines, the dimensions of which are given in the following table.

DIMENSIONS, ETC., OF ENGINES.

Engine, No.....	1 and 2.	3 and 4.	5 and 6.
Indicated horse-power.....I.H.P.	50	450	1250
Diam. of cyl., in..... <i>D</i>	10	30	50
Stroke, feet..... <i>L</i>	1 ... 2	2 $\frac{1}{2}$ ... 5	4 ... 8
Revs. per min..... <i>r</i>	250 ... 125	130 ... 65	90 ... 45
Piston speed, ft. per min..... <i>S</i>	500	650	700
Area of piston, sq. in..... <i>a</i>	78.54	706.86	1963.5
Mean effective pressure.....M.E.P.	42	32.3	30
Max. total unbalanced pressure..... <i>P</i>	7854	70,686	196,350
Max. total pressure per sq. in..... <i>p</i>	100	100	100

The thickness of the cylinders of these engines, according to the eleven formulæ, ranges for engines 1 and 2 from 0.33 to 1.13 in., for 3 and 4 from 0.99 to 2.00 in., and for 5 and 6 from 1.56 to 3.00 in. The averages of the eleven are, for 1 and 2, 0.76 in.; for 3 and 4, 1.48 in.; for 5 and 6, 2.26 in.

The average corresponds nearly to the formula  $t = 0.00037 Dp + 0.4$  in. A convenient approximation is  $t = 0.0004 Dp + 0.3$  in., which gives for

Diameters..... 10 20 30 40 50 60 in.  
 Thicknesses.....0.70 1.10 1.50 1.90 2.30 2.70 in.

The last formula corresponds to a tensile strength of cast iron of 12,500 lb., with a factor of safety of 10 and an allowance of 0.3 in. for reborring.

**Thickness of Cylinder and Its Connections for Marine Engines.** (Seaton.)—*D* = the diam. of the cylinder in inches; *p* = load on the safety-valves in lb. per sq. in.; *f*, a constant multiplier, = thickness of barrel + 0.25 in.



Thickness of metal of cylinder barrel or liner, not to be less than  $p \times D \div 3000$  when of cast iron.\*

Thickness of cylinder-barrel =  $p \times D \div 5000 + 0.6$  in.

Thickness of liner =  $1.1 \times f$

Thickness of liner when of steel =  $p \times D \div 6000 + 0.5$  in.

Thickness of metal of steam-ports =  $0.6 \times f$ .

Thickness of metal valve-box sides =  $0.65 \times f$ .

Thickness of metal of valve-box covers	=	$0.7 \times f$ .
“ “ “ cylinder bottom	=	$1.1 \times f$ , if single thickness.
“ “ “ “	=	$0.65 \times f$ , if double “
“ “ “ covers	=	$1.0 \times f$ , if single “
“ “ “ “	=	$0.6 \times f$ , if double “
“ “ cylinder flange	=	$1.4 \times f$ .
“ “ cover-flange	=	$1.3 \times f$ .
“ “ valve-box flange	=	$1.0 \times f$ .
“ “ door-flange	=	$0.9 \times f$ .
“ “ face over ports	=	$1.2 \times f$ .
“ “ “ “	=	$1.0 \times f$ , when there is a false-face.
“ “ false-face	=	$0.8 \times f$ , when cast iron.
“ “ “	=	$0.6 \times f$ , when steel or bronze.

**Cylinder-heads.**—Applying six different formulæ to the engines of 10, 30, and 50 inches diameter, with maximum unbalanced steam-pressure of 100 lb. per sq. in., we have

For cylinder 10 in. diam., 0.35 to 1.15 in.; for 30 in. diam., 0.90 to 1.75 in.; for 50-in. diam., 1.50 to 2.75 in. The averages are respectively 0.65, 1.38, and 2.10 in.

The average is expressed by the formula  $t = 0.00036 Dp + 0.31$  inch.

**Web-stiffened Cylinder-covers.**—Seaton objects to webs for stiffening cast-iron cylinder-covers as a source of danger. The strain on the web is one of tension, and if there should be a nick or defect in the outer edge of the web the sudden application of strain is apt to start a crack. He recommends that high-pressure cylinders over 24 in. and low-pressure cylinders over 40 in. diam. should have their covers cast hollow, with two thicknesses of metal. The depth of the cover at the middle should be about  $\frac{1}{4}$  the diam. of the piston for pressures of 80 lb. and upwards, and that of the low-pressure cylinder-cover of a compound engine equal to that of the high-pressure cylinder. Another rule is to make the depth at the middle not less than 1.3 times the diameter of the piston-rod. In the British Navy the cylinder-covers are made of steel castings,  $\frac{3}{4}$  to  $1\frac{1}{4}$  in. thick, generally cast without webs, stiffness being obtained by their form, which is often a series of corrugations.

**Cylinder-head Bolts.**—Diameter of bolt-circle for cylinder-head = diameter of cylinder +  $2 \times$  thickness of cylinder +  $2 \times$  diameter of bolts. The bolts should not be more than 6 in. apart (Whitham).

Marks gives for number of bolts  $b = 0.7854 D^2p \div 5000 c$ , in which  $c$  = area of a single bolt,  $p$  = boiler-pressure in lb. per sq. in.; 5000 lb. is taken as the safe strain per sq. in. on the nominal area of the bolt.

Thurston says: Cylinder flanges are made a little thicker than the cylinder, and usually of equal thickness with the flanges of the heads. Cylinder-bolts should be so closely spaced as not to allow springing of the flanges and leakage, say, 4 to 5 times the thickness of the flanges. Their diameter should be proportioned for a maximum stress of not over 4000 to 5000 lb. per square inch.

If  $D$  = diameter of cylinder,  $p$  = maximum steam-pressure,  $b$  = number of bolts,  $s$  = size or diameter of each bolt, and 5000 lb. be allowed per sq. in. of actual area at the root of the thread,  $0.7854 D^2p = 3927 bs^2$ ; whence  $bs^2 = 0.0002 D^2p$ .

$$b = 0.0002 \frac{D^2p}{s^2}; s = 0.01414 D \sqrt{\frac{p}{b}}. \text{ For the three engines we have:}$$

\* When made of exceedingly good material, at least twice melted, the thickness may be 0.8 of that given by the above rules.

Diameter of cylinder, inches . . . . .	10	30	50
Diameter of bolt-circle, approx. . . . .	13	35	57.5
Circumference of circle, approx. . . . .	40.8	110	180
Minimum no. of bolts, circ. ÷ 6 . . . . .	7	18	30

Diam of bolts,  $s = 0.01414 D \sqrt{\frac{p}{b}}$  . . . . .  $\frac{3}{4}$  in. 1.00 1.29

The diameter of bolt for the 10-inch cylinder is 0.54 in. by the formula, but  $\frac{3}{4}$  inch is as small as should be taken, on account of possible over-strain by the wrench in screwing up the nut.

**The Piston. Details of Construction of Ordinary Pistons.** (Seaton.)  
—Let  $D$  be the diameter of the piston in inches,  $p$  the effective pressure per square inch on it,  $x$  a constant multiplier, found as follows:

$$x = (D \div 50) \times \sqrt{p + 1}.$$

The thickness of front of piston near the boss	= 0.2 × $x$ .
“ “ “ “ rim	= 0.17 × $x$ .
“ back “	= 0.18 × $x$ .
“ boss around the rod	= 0.3 × $x$ .
“ flange inside packing-ring	= 0.23 × $x$ .
“ “ at edge	= 0.25 × $x$ .
“ packing-ring	= 0.15 × $x$ .
“ junk-ring at edge	= 0.23 × $x$ .
“ “ inside packing-ring	= 0.21 × $x$ .
“ “ at bolt-holes	= 0.35 × $x$ .
“ metal around piston edge	= 0.25 × $x$ .
The breadth of packing-ring	= 0.63 × $x$ .
“ depth of piston at center	= 1.4 × $x$ .
“ lap of junk-ring on the piston	= 0.45 × $x$ .
“ space between piston body and packing-ring	= 0.3 × $x$ .
“ diameter of junk-ring bolts	= 0.1 × $x$ + 0.25 in.
“ pitch of junk-ring bolts	= 10 diameters.
“ number of webs in the piston	= $(D + 20) \div 12$ .
“ thickness of webs in the piston	= 0.18 × $x$ .

Marks gives the approximate rule: Thickness of piston-head =  $\sqrt[4]{lD}$ , in which  $l$  = length of stroke, and  $D$  = diameter of cylinder in inches. Whitham says: In a horizontal engine the rings support the piston, or at least a part of it, under ordinary conditions. The pressure due to the weight of the piston upon an area equal to 0.7 the diameter of the cylinder × breadth of ring-face, should never exceed 200 lb. per sq. in. He also gives a formula much used in this country: Breadth of ring-face = 0.15 × diameter of cylinder.

For our engines we have diameter = . . . . .	10	30	50
	Thickness of piston-head.		
Marks, $\sqrt[4]{lD}$ ; long stroke . . . . .	3.31	5.48	7.00
Marks, $\sqrt[4]{lD}$ ; short stroke . . . . .	3.94	6.51	8.32
Seaton, depth at center = 1.4 $x$ . . . . .	4.20	9.80	15.40
Seaton, breadth of ring = 0.63 $x$ . . . . .	1.89	4.41	6.93
Whitham, breadth of ring = 0.15 $D$ . . . . .	1.50	4.50	7.50

**Diameter of Piston Packing-rings.**—These are generally turned, before they are cut, about  $\frac{1}{4}$  inch diameter larger than the cylinder, for cylinders up to 20 inches diameter, and then enough is cut out of the rings to spring them to the diameter of the cylinder. For larger cylinders the rings are turned proportionately larger. Seaton recommends an excess of 1% of the diameter of the cylinder.

A theoretical paper on Piston Packing Rings of Modern Steam Engines by O. C. Reymann will be found in *Jour. Frank. Inst.*, Aug., 1897.

**Cross-section of the Rings.**—The thickness is commonly made  $\frac{1}{30}$  of the diam. of cyl. +  $\frac{1}{8}$  inch, and the width = thickness +  $\frac{1}{3}$  inch. For an eccentric ring the mean thickness may be the same as for a ring of uniform thickness, and the minimum thickness =  $\frac{2}{3}$  the maximum.

A circular issued by J. H. Dunbar, manufacturer of packing-rings, Youngstown, Ohio, says: Unless otherwise ordered, the thickness of rings will be made equal to 0.03 × their diameter. This thickness has been found to be satisfactory in practice. It admits of the ring being

made about  $\frac{3}{16}$  in. to the foot larger than the cylinder, and has, when new, a tension of about two pounds per inch of circumference, which is ample to prevent leakage if the surface of the ring and cylinder are smooth.

As regards the width of rings, authorities "scatter" from very narrow to very wide, the latter being fully ten times the former. For instance, Unwin gives  $W = 0.014 d + 0.08$ . Whitham's formula is  $W = 0.15 d$ . In both formulæ  $W$  is the width of the ring in inches, and  $d$  the diameter of the cylinder in inches. Unwin's formula makes the width of a 20-in. ring  $W = 20 \times 0.014 + 0.08 = 0.36$  in., while Whitham's is  $20 \times 0.15 = 3$  in. for the same diameter of ring. There is much less difference in the practice of engine-builders in this respect, but there is still room for a standard width of ring. It is believed that for cylinders over 16 in. diameter  $\frac{3}{4}$  in. is a popular and practical width, and  $\frac{1}{2}$  in. for cylinders of that size and under.

**Fit of Piston-rod into Piston.** (Seaton.)—The most convenient and reliable practice is to turn the piston-rod end with a shoulder of  $\frac{1}{16}$  inch for small engines, and  $\frac{1}{8}$  inch for large ones, make the taper 3 in. to the foot until the section of the rod is three-fourths of that of the body, then turn the remaining part parallel; the rod should then fit into the piston so as to leave  $\frac{1}{8}$  in. between it and the shoulder for large pistons and  $\frac{1}{16}$  in. for small. The shoulder prevents the rod from splitting the piston, and allows of the rod being turned true after long wear without encroaching on the taper.

The piston is secured to the rod by a nut, and the size of the rod should be such that the strain on the section at the bottom of the thread does not exceed 5500 lb. per sq. in. for iron, 7000 lb. for steel. The depth of this nut need not exceed the diameter which would be found by allowing these strains. The nut should be locked to prevent its working loose.

**Diameter of Piston-rods.**—Taking  $d$  = diam. of piston-rod,  $D$  = diam. of piston,  $l$  = length of stroke,  $p$  = maximum unbalanced pressure, lb. per sq. in., Unwin gives, for iron rods,  $d = 0.0167 D\sqrt{p}$ ; steel,  $0.0144 D\sqrt{p}$ . Marks gives: (1)  $d = 0.0179 D\sqrt{p}$  for iron; (2)  $0.0105 D\sqrt{p}$  for steel; and (3)  $d = 0.0390 \sqrt[4]{D^2lp}$  for iron; (4)  $0.0352 \sqrt[4]{D^2lp}$  for steel. Deduce the diameter of the rod by (1) or (2) and if this diameter is less than  $\frac{1}{12}l$  then use (3) or (4). Applying these four formulæ to the six engines and taking the average results, we have the following:

**Diameter of Piston-rods.**

Diameter of Cylinder, inches.....	10		30		50	
	12	24	30	60	48	96
Stroke, inches.....	1.49	1.82	4.30	5.26	7.11	8.74
Diam. of rod, average for iron.....	1.33	1.59	3.83	4.52	6.33	7.46
“ “ average for steel.....						

An empirical formula which gives results approximating the above averages is  $d'' = c\sqrt{Dlp}$ , the values of  $c$  being for short stroke engines, iron, 0.0145; steel, 0.0129; and for long stroke engines, iron, 0.0126, steel, 0.0108.

The calculated results for this formula, for the six engines, are, respectively:

Iron.....	1.59	1.95	4.35	5.36	7.11	8.73
Steel.....	1.31	1.67	3.87	4.58	6.32	7.48

In considering an expansive engine,  $p$ , the effective pressure, should be taken as the absolute working pressure, or 15 lb. above that to which the boiler safety-valve is loaded; for a compound engine the value of  $p$  for the high-pressure piston should be taken as the absolute pressure, less 15 lb., or the same as the load on the safety-valve; for the medium-pressure the load may be taken as that due to half the absolute boiler-pressure; and for the low-pressure cylinder the pressure to which the escape-valve is loaded + 15 lb., or the maximum absolute pressure which can be got in the receiver, or about 25 lb. It is an advantage to make all the rods of a compound engine alike, and this is now the rule.

**Piston-rod Guides.**—The thrust on the guide, when the connecting-



rod is at its maximum angle with the line of the piston-rod, is found from the formula: Thrust = total load on piston  $\times$  tangent of maximum angle of connecting-rod =  $p \tan \theta$ . This angle,  $\theta$ , is the angle whose sine = half stroke of piston  $\div$  length of connecting-rod.

Ratio of length of connecting-rod to stroke..	2	2 1/2	3
Maximum angle of connecting-rod with line of piston-rod.....	14° 29'	11° 33'	9° 36'
Tangent of the angle.....	0.258	0.204	0.169
Secant of the angle.....	1.0327	1.0206	1.014

Thurston says: The rubbing surfaces of guides are so proportioned that if  $V$  be their relative velocity in feet per minute, and  $p$  be the intensity of pressure on the guide in lb. per sq. in.,  $pV < 60,000$  and  $pV > 40,000$ .

The lower is the safer limit; but for marine and stationary engines it is allowable to take  $p = 60,000 \div V$ . According to Rankine, for locomotives,  $p = \frac{44,800}{V + 20}$ , where  $p$  is the pressure in lb. per sq. in. and  $V$  the velocity of rubbing in feet per minute. This includes the sum of all pressures forcing the two rubbing surfaces together.

Some British builders of portable engines restrict the pressure between the guides and cross-heads to less than 40, sometimes 35 lb. per sq. in.

For a mean velocity of 600 feet per minute, Prof. Thurston's formulæ give,  $p < 100$ ,  $p > 66.7$ ; Rankine's gives  $p = 72.2$  lb. per sq. in.

Whitham gives,

$$A = \text{area of slides in square inches} = \frac{P}{p_0 \sqrt{n^2 - 1}} = \frac{0.7854 d^2 p_1}{p_0 \sqrt{n^2 - 1}}$$

in which  $P$  = total unbalanced pressure,  $p_1$  = pressure per square inch on piston,  $d$  = diameter of cylinder,  $p_0$  = pressure allowable per square inch on slides, and  $n$  = length of connecting-rod  $\div$  length of crank. This is equivalent to the formula,  $A = P \tan \theta \div p_0$ . For  $n = 5$ ,  $p_1 = 100$  and  $p_0 = 80$ ,  $A = 0.2004 d^2$ . For the three engines 10, 30, and 50 in. diam., this would give for area of slides,  $A = 20, 180$ , and  $500$  sq. in., respectively. Whitham says: The normal pressure on the slide may be as high as 500 lb. per sq. in., but this is when there is good lubrication and freedom from dust. Stationary and marine engines are usually designed to carry 100 lb. per sq. in., and the area in this case is reduced from 50% to 60% by grooves. In locomotive engines the pressure ranges from 40 to 50 lb. per sq. in. of slide, on account of the inaccessibility of the slide, dirt, cinder, etc.

**The Connecting-rod.** *Ratio of length of connecting-rod to length of stroke.*—Experience has led generally to the ratio of 2 or 2 1/2 to 1, the latter giving a long and easy-working rod, the former a rather short, but yet a manageable one (Thurston). Whitham gives the ratio of from 2 to 4 1/2 and Marks from 2 to 4.

*Dimensions of the Connecting-rod.*—The calculation of the diameter of a connecting-rod on a theoretical basis, considering it as a strut subject to both compressive and bending stresses, and also to stress due to its inertia, in high-speed engines, is quite complicated. See Whitham, *Steam-engine Design*, p. 217; Thurston, *Manual of S. E.*, p. 100.

Applying seven formulæ given by different authorities to the six engines the average diameters (at the middle of the rod) are given below:

**Diameter of Connecting-rods.**

Diameter of Cylinder, inches.....	10		30		50	
	12	24	30	60	48	96
Stroke, inches.....	12	24	30	60	48	96
Length of connecting-rod $l$ .....	30	60	75	150	120	240
Diameter of rod, inches.....	2.24	2.26	6.38	6.27	10.52	10.26

The average figures show but little difference in diameter between long- and short-stroke engines; this is what might be expected, for while the connecting-rod, considered simply as a column, would require an increase of diameter for an increase of length, the load remaining the

same, yet in an engine generally the shorter the connecting-rod the greater the number of revolutions, and consequently the greater the strains due to inertia. The influences tending to increase the diameter therefore tend to balance each other, and to render the diameter to some extent independent of the length. The average figures correspond nearly to the simple formula  $d = 0.021 D\sqrt{p}$ . The diameters of rod for the three diameters of engine by this formula are, respectively, 2.10, 6.30, and 10.50 in. Since the total pressure on the piston  $P = 0.7854 D^2 p$ , the formula is equivalent to  $d = 0.0237 \sqrt{P}$ .

Seaton and Sennett give the diameter at the necks of a connecting-rod = 0.9 the diam. at the middle. Whitham gives it as 1.0 to 1.1 the diam. of the piston-rod.

**Connecting-rod Ends.**—For a connecting-rod end of the marine type, where the end is secured with two bolts, each bolt should be proportioned for a safe tensile strength equal to two-thirds of the maximum pull or thrust in the connecting-rod.

The cap is to be proportioned as a beam loaded with the maximum pull of the connecting-rod, and supported at both ends. The calculation should be made for rigidity as well as strength, allowing a maximum deflection of  $1/100$  inch. For a strap-and-key connecting-rod end the strap is designed for tensile strength, considering that two-thirds of the pull on the connecting-rod may come on one arm. At the point where the metal is slotted for the key and gib, the straps must be thickened to make the cross-section equal to that of the remainder of the strap. Between the end of the strap and the slot the strap is liable to fail in double shear, and sufficient metal must be provided at the end to prevent such failure.

The breadth of the key is generally one-fourth of the width of the strap, and the length, parallel to the strap, should be such that the cross-section will have a shearing strength equal to the tensile strength of the section of the strap. The taper of the key is generally about  $5/8$  inch to the foot.

**Tapered Connecting-rods.**—In modern high-speed engines it is customary to make the connecting-rods of rectangular instead of circular section, the sides being parallel, and the depth increasing regularly from the cross-head end to the crank-pin end. According to Grashof, the bending action on the rod due to its inertia is greatest at  $6/10$  the length from the cross-head end, and, according to this theory, that is the point at which the section should be greatest, although in practice the section is made greatest at the crank-pin end.

Professor Thurston furnished the author with the following rule for tapered connecting-rods of rectangular section: Take the section as computed by the formula  $d'' = 0.1 \sqrt{DL\sqrt{p}} + 3/4$  for a circular section, and for a rod  $4/3$  the actual length, placing the computed section at  $2/3$  the length from the small end, and carrying the taper straight through this fixed section to the large end. This brings the computed section at the surge point and makes it heavier than the rod for which a tapered form is not required.

Taking the above formula, multiplying  $L$  by  $4/3$ , and changing it to  $l$  in inches, it becomes  $d = 1/30 \sqrt{Dl\sqrt{p}} + 3/4$  in. Taking a rectangular section of the same area as the round section whose diameter is  $d$ , and making the depth of the section  $h =$  twice the thickness  $t$ , we have  $0.7854 d^2 = ht = 2 t^2$ , whence  $t = 0.627$ ;  $d = 0.0209 \sqrt{Dl\sqrt{p}} + 0.47$  in., which is the formula for the thickness or distance between the parallel sides of the rod. Making the depth at the cross-head end =  $1.5 t$ , and at  $2/3$  the length =  $2 t$ , the equivalent depth at the crank end is  $2.25 t$ . Applying the formula to the short-stroke engines of our examples, we have

Diameter of cylinder, inches.....	10	30	50
Stroke, inches.....	12	30	48
Length of connecting-rod.....	30	75	120
Thickness, $t = 0.0209 \sqrt{Dl\sqrt{p}} + 0.47 =$ .....	1.61	3.60	5.59
Depth at cross-head end, $1.5 t =$ .....	2.42	5.41	8.39
Depth at crank end, $2 1/4 t$ .....	3.62	8.11	12.58

The thicknesses  $t$ , found by the formula  $t = 0.0209 \sqrt{Dl\sqrt{p}} + 0.47$ , agree closely with the more simple formula  $t = 0.01 D\sqrt{p} + 0.60$  in., the thicknesses calculated by this formula being respectively 1.6, 3.6, and 5.6 in.

**The Crank-Pin.**—A crank-pin should be designed (1) to avoid heating, (2) for strength, (3) for rigidity. The heating of a crank-pin depends on the pressure on its rubbing surface, and on the coefficient of friction, which latter varies greatly, according to the effectiveness of the lubrication. It also depends upon the facility with which the heat produced may be carried away: thus it appears that locomotive crank-pins may be prevented to some degree from overheating by the cooling action of the air through which they pass at a high speed.

Marks states as a general law, within reasonable limits as to pressure and speed of rubbing, the longer a bearing is made, for a given pressure and number of revolutions, the cooler it will work; and its diameter has no effect upon its heating.

Whitham recommends for pressure per square inch of projected area, for naval engines 500 pounds, for merchant marine engines 400 pounds, for paddle-wheel engines 800 to 900 pounds.

Thurston says the pressure on a steel crank-pin should, in the steam-engine, never exceed 1000 or 1200 pounds per square inch. He gives the formula for length of a steel pin, in inches.

$$l = PR \div 600,000,$$

in which  $P$  and  $R$  are the mean total load on the pin in pounds, and the number of revolutions per minute. For locomotives, the divisor may be taken as 500,000. Pins so proportioned, if well made and well lubricated, may always be depended upon to run cool; if not well formed, perfectly cylindrical, well finished, and kept well oiled, no crank-pin can be relied upon. It is assumed above that good bronze or white-metal bearings are used.

By calculating lengths of iron crank-pins for the engines 10, 30, and 50 inches diameter, long and short stroke, by the formulæ given by different writers, it is found that there is a great difference in the results, so that one formula in certain cases gives a length three times as great as another.

The average of the calculated lengths of iron crank-pins for the several cases by five formulæ are given in the table below, together with the calculated lengths by two formulæ for steel.

**Length of Crank-pins.**

Diameter of cylinder..... $D$	10	10	30	30	50	50
Stroke..... $L$ (ft.)	1	2	2½	5	4	8
Revolutions per minute..... $R$	250	125	130	65	90	45
Horse-power.....I.H.P.	50	50	450	450	1,250	1,250
Maximum pressure.....lbs.	7,854	7,854	70,686	70,686	196,350	196,350
Mean pressure per cent of max.....	42	42	32.3	32.3	30	30
Mean pressure..... $P$ .	3,299	3,299	22,832	22,832	58,905	58,905
Length of crank-pin, average for iron..	2.72	1.36	9.86	4.93	17.12	8.56
Unwin, best steel, $l = 0.1$ I.H.P. $\div r$ .....	0.83	0.42	3.0	1.5	5.21	2.61
Thurston, steel, $l = PR \div 600,000$ .....	1.37	0.69	4.95	2.47	8.84	4.42

The calculated lengths for the long-stroke engines are too low to prevent excessive pressures. See "Pressures on the Crank-pins," below.

**The Strength of the Crank-pin** is determined substantially as is that of the crank. In overhung cranks the load is usually assumed as carried at the middle of the pin, and, equating its moment with that of the resistance of the pin,

$$\frac{1}{2} Pl = \frac{1}{32} t\pi d^3, \text{ and } d = \sqrt[3]{\frac{5.1 Pl}{t}},$$

in which  $d$  = diameter of pin in inches,  $P$  = maximum load on the piston,  $t$  = the maximum allowable stress on a square inch of the metal. For iron it may be taken at 9000 lbs. For steel the diameters found by this formula may be reduced 10%. (Thurston.)



Unwin gives the same formula in another form, viz.:

$$d = \sqrt[3]{\frac{5.1}{t}} \sqrt[3]{Pl} = \sqrt{\frac{5.1}{t}} \sqrt{P \frac{l}{d}}$$

the last form to be used when the ratio of length to diameter is assumed.

For wrought iron,  $t = 6000$  to  $9000$  lbs. per sq. in.,

$$\sqrt[3]{5.1/t} = 0.0947 \text{ to } 0.0827; \quad \sqrt{5.1/t} = 0.0291 \text{ to } 0.0238.$$

For steel,  $t = 9000$  to  $13,000$  lbs. per sq. in.,

$$\sqrt[3]{5.1/t} = 0.0827 \text{ to } 0.0723; \quad \sqrt{5.1/t} = 0.0238 \text{ to } 0.0194.$$

Marks, calculating the diameter for rigidity, gives

$$d = 0.066 \sqrt[4]{pl^3D^2} = 0.945 \sqrt[4]{(\text{H.P.})l^3 + LN};$$

$p$  = maximum steam-pressure in pounds per square inch,  $D$  = diameter of cylinder in inches,  $L$  = length of stroke in feet,  $N$  = number of single strokes per minute. He says there is no need of an investigation of the strength of a crank-pin, as the condition of rigidity gives a great excess of strength.

Marks's formula is based upon the assumption that the whole load may be concentrated at the outer end, and cause a deflection of 0.01 in. at that point. It is serviceable, he says, for steel and for wrought iron alike.

Using the average lengths of the crank-pins already found, we have the following for our six engines:

#### Diameter of Crank-pins.

Diameter of cylinder.....	10	10	30	30	50	50
Stroke, ft.....	1	2	21/2	5	4	8
Length of crank-pin.....	2.72	1.36	9.86	4.93	17.12	8.56
Unwin, $d = \sqrt[3]{\frac{5.1 Pl}{t}}$ .....	2.29	1.82	7.34	5.82	12.40	9.84
Marks, $d = 0.066 \sqrt[4]{pl^3D^2}$ .....	1.39	0.85	6.44	3.78	12.41	7.39

**Pressures on the Crank-pins.** — If we take the mean pressure upon the crank-pin = mean pressure on piston, neglecting the effect of the varying angle of the connecting-rod, we have the following, using the average lengths already found, and the diameters according to Unwin and Marks:

Engine No.....	1	2	3	4	5	6
Diameter of cylinder, inches.....	10	10	30	30	50	50
Stroke, feet.....	1	2	21/2	5	4	8
Mean pressure on pin, pounds.....	3,299	3,299	22,832	22,832	58,905	58,905
Projected area of pin, Unwin.....	6.23	2.36	72.4	28.7	212.3	84.2
Projected area of pin, Marks.....	3.78	1.16	63.5	18.6	212.5	63.3
Pressure per square inch, Unwin.....	530	1,398	315	796	277	700
Pressure per square inch, Marks.....	873	2,845	360	1,228	277	930

The results show that the application of the formulæ for length and diameter of crank-pins give quite low pressures per square inch of projected area for the short-stroke high-speed engines of the larger sizes, but too high pressures for all the other engines. It is therefore evident that after calculating the dimensions of a crank-pin according to the formulæ given, the results should be modified, if necessary, to bring the pressure per square inch down to a reasonable figure.

In order to bring the pressures down to 500 pounds per square inch, we divide the mean pressures by 500 to obtain the projected area, or

product of length by diameter. Making  $l = 1.5 d$  for engines Nos. 1, 2, 4, and 6, the revised table for the six engines is as follows:

Engine No. . . . .	1	2	3	4	5	6
Length of crank-pin, inches..	3.15	3.15	9.86	8.37	17.12	13.30
Diameter of crank-pin.....	2.10	2.10	7.34	5.58	12.40	8.87

**Crosshead-pin or Wrist-pin.**—Seaton says the area, calculated by multiplying the diameter of the journal by its length, should be such that the pressure does not exceed 1200 lb. per sq. in., taking the maximum load on the piston as the total pressure on the pin.

For small engines with the gudgeon shrunk into the jaws of the connecting-rod, and working in brasses fitted into a recess in the piston-rod end and secured by a wrought-iron cap and two bolts, Seaton gives:

- Diameter of gudgeon =  $1.25 \times$  diam. of piston-rod,
- Length of gudgeon =  $1.4 \times$  diam. of piston-rod.

If the pressure on the section, as calculated by multiplying length by diameter, exceeds 1200 lbs. per sq. in., this length should be increased.

J. B. Stanwood, in his "Ready Reference" book, gives for length of crosshead-pin 0.25 to 0.3 diam. of piston, and diam. = 0.18 to 0.2 diam. of piston. Since he gives for diam. of piston-rod 0.14 to 0.17 diam. of piston, his dimensions for diameter and length of crosshead-pin are about 1.25 and 1.8 diam. of piston-rod respectively. Taking the maximum allowable pressure at 1200 lbs. per sq. in. and making the length of the crosshead-pin =  $\frac{4}{3}$  of its diameter, we have  $d = \sqrt{P + 40}$ ,  $l = \sqrt{P + 30}$ , in which  $P =$  maximum total load on piston in lbs.,  $d =$  diam. and  $l =$  length of pin in inches. For the engines of our example we have:

Diameter of piston, inches.....	10	30	50
Maximum load on piston, lbs.....	7854	70,686	196,350
Diameter of crosshead-pin, inches....	2.22	6.65	11.08
Length of crosshead-pin, inches.....	2.96	8.86	14.77
Stanwood's rule gives diameter, ins....	1.8 to 2	5.4 to 6	9.0 to 10
Stanwood's rule gives length, inches...	2.5 to 3	7.5 to 9	12.5 to 15
Stanwood's largest dimensions give pressure per sq. in., lbs.....	1309	1329	1309

These pressures are greater than the maximum allowed by Seaton.

**The Crank-arm.**—The crank-arm is to be treated as a lever, so that if  $a$  is the thickness in a direction parallel to the shaft-axis and  $b$  its breadth at a section  $x$  inches from the crank-pin center, then, bending moment  $M$  at that section =  $Px$ ,  $P$  being the thrust of the connecting-rod, and  $f$  the safe strain per square inch,

$$Px = \frac{fab^2}{6} \text{ and } \frac{a \times b^2}{6} = \frac{T}{f}, \text{ or } a = \frac{6 T}{b^2 \times f}; b = \sqrt{\frac{6 T}{fa}}$$

If a crank-arm were constructed so that  $b$  varied as  $\sqrt{x}$  (as given by the above rule) it would be of such a curved form as to be inconvenient to manufacture, and consequently it is customary in practice to find the maximum value of  $b$  and draw tangent lines to the curve at the points; these lines are generally, for the same reason, tangential to the boss of the crank-arm at the shaft.

The shearing strain is the same throughout the crank-arm; and, consequently, is large compared with the bending strain close to the crank-pin; and so it is not sufficient to provide there only for bending strains. The section at this point should be such that, in addition to what is given by the calculation from the bending moment, there is an extra square inch for every 8000 lbs. of thrust on the connecting-rod (Seaton).

The length of the boss  $h$  into which the shaft is fitted is from 0.75 to 1.0 of the diameter of the shaft  $D$ , and its thickness  $e$  must be calculated from the twisting strain  $PL$ . ( $L =$  length of crank.)

For different values of length of boss  $h$ , the following values of thickness of boss  $e$  are given by Seaton:

- When  $h = D$ , then  $e = 0.35 D$ ; if steel, 0.3.
- $h = 0.9D$ , then  $e = 0.38 D$ ; if steel, 0.32.
- $h = 0.8D$ , then  $e = 0.40 D$ ; if steel, 0.33.
- $h = 0.7D$ , then  $e = 0.41 D$ ; if steel, 0.34.

The crank-eye or boss into which the pin is fitted should bear the same relation to the pin that the boss does to the shaft.

The diameter of the shaft-end onto which the crank is fitted should be  $1.1 \times$  diameter of shaft.

Thurston says: The empirical proportions adopted by builders will commonly be found to fall well within the calculated safe margin. These proportions are, from the practice of successful designers, about as follows:

The hub is 1.75 to 1.8 times the least diameter of that part of the shaft carrying full load; the eye is 2.0 to 2.25 the diameter of the inserted portion of the pin, and their depths are, for the hub, 1.0 to 1.2 the diameter of shaft, and for the eye, 1.25 to 1.5 the diameter of pin. The web is made 0.7 to 0.75 the width of the adjacent hub or eye, and is given a depth of 0.5 to 0.6 that of the adjacent hub or eye.

The crank-shaft is usually enlarged at the seat of the crank to about 1.1 its diameter at the journal. The size should be nicely adjusted to allow for the shrinkage or forcing on of the crank. A difference of diameter of 0.2% will usually suffice.

The formulæ given by different writers for crank-arms practically agree, since they all consider the crank as a beam loaded at one end and fixed at the other. The relation of breadth to thickness may vary according to the taste of the designer. Calculated dimensions for our six engines are as follows:

**Dimensions of Crank-arms.**

Diam. of cylinder, ins.....	10	10	30	30	50	50
Stroke <i>S</i> , ins.....	12	24	30	60	48	96
Max. pressure on pin <i>P</i> (approx.), lbs .....	7854	7854	70,686	70,686	196,350	196,350
Diam. crank-pin <i>d</i> .....	2.10	2.10	7.34	5.58	12.40	8.87
Dia. shaft, $a \sqrt[3]{\frac{\text{I.H.P.}}{R}}$ , <i>D</i> ( <i>a</i> = 4.69, 5.09 and 5.22)....	2.74	3.46	7.70	9.70	12.55	15.82
Length of boss, 0.8 <i>D</i> .....	2.19	2.77	6.16	7.76	10.04	12.65
Thickness of boss, 0.4 <i>D</i> ....	1.10	1.39	3.08	3.88	5.02	6.32
Diam. of boss, 1.8 <i>D</i> .....	4.93	6.23	13.86	17.46	22.59	28.47
Length crank-pin eye, 0.8 <i>d</i>	1.76	1.76	5.87	4.46	9.92	7.10
Thickness of crank-pin eye, 0.4 <i>d</i> .....	0.88	0.88	2.94	2.23	4.46	3.55
Max. mom. <i>T</i> at distance $\frac{1}{2}S - \frac{1}{2}D$ from center of pin, inch-lbs .....	37,149	80,661	788,149	1,848,439	3,479,322	7,871,671
Thickness of crank-arm <i>a</i> = 0.75 <i>D</i> .....	2.05	2.60	5.78	7.28	9.41	11.87
Greatest breadth, $b = \sqrt{6 T \div 9000 a}$	3.48	4.55	9.54	13.0	15.7	21.0
Min. mom. <i>T</i> <sub>0</sub> at distance <i>d</i> from center of pin = <i>Pd</i> .	16,493	16,493	528,835	394,428	2,434,740	1,741,625
Least breadth, $b_1 = \sqrt{6 T_0 \div 9000 a}$	2.32	2.06	7.81	6.01	13.13	9.89

**The Shaft. — Twisting Resistance.** — From the general formula for torsion, we have:  $T = \frac{\pi}{16} d^3 S = 0.19635 d^3 S$ , whence  $d = \sqrt[3]{\frac{5.1 T}{S}}$ , in which *T* = torsional moment in inch-pounds, *d* = diameter in inches, and *S* = the shearing resistance of the material, lb. per sq. in.

If a constant force *P* were applied to the crank-pin tangentially to its path, the work done per minute would be

$$P \times L \times 2\pi \div 12 \times R = 33,000 \times \text{I.H.P.},$$

in which *L* = length of crank in inches, and *R* = revs. per min., and the mean twisting moment  $T = \text{I.H.P.} \div R \times 63,025$ . Therefore

$$d = \sqrt[3]{5.1 T \div S} = \sqrt[3]{321,427 \text{ I.H.P.} \div RS}.$$



This may take the form

$$d = \sqrt[3]{I.H.P. \times F/R}, \text{ or } d = a \sqrt[3]{I.H.P. \div R},$$

in which  $F$  and  $a$  are factors that depend on the strength of the material and on the factor of safety. Taking  $S$  at 45,000 pounds per square inch for wrought iron, and at 60,000 for steel, we have, for simple twisting by a uniform tangential force,

Factor of safety	=	5	6	8	10	5	6	8	10
Iron . . . . . $F$	=	35.7	42.8	57.1	71.4	$a = 3.3$	3.5	3.85	4.15
Steel . . . . . $F$	=	26.8	32.1	42.8	53.5	$a = 3.0$	3.18	3.5	3.77

Unwin, taking for safe working strength of wrought iron 9000 lbs., steel 13,500 lbs., and cast iron 4500 lbs., gives  $a = 3.294$  for wrought iron, 2.877 for steel, and 4.15 for cast iron. Thurston, for crank-axes of wrought iron, gives  $a = 4.15$  or more.

Seaton says: For wrought iron,  $f$ , the safe strain per square inch, should not exceed 9000 lbs., and when the shafts are more than 10 inches diameter, 8000 lbs. Steel, when made from the ingot and of good materials, will admit of a stress of 12,000 lbs. for small shafts, and 10,000 lbs. for those above 10 inches diameter.

The difference in the allowance between large and small shafts is to compensate for the defective material observable in the heart of large shafting, owing to the hammering failing to affect it.

The formula  $d = a \sqrt[3]{I.H.P. \div R}$  assumes the tangential force to be uniform and that it is the only acting force. For engines, in which the tangential force varies with the angle between the crank and the connecting-rod, and with the variation in steam-pressure in the cylinder, and also is influenced by the inertia of the reciprocating parts, and in which also the shaft may be subjected to bending as well as torsion, the factor  $a$  must be increased, to provide for the maximum tangential force and for bending.

Seaton gives the following table showing the relation between the maximum and mean twisting moments of engines working under various conditions, the momentum of the moving parts being neglected, which is allowable:

Description of Engine.	Steam Cut-off at	Max. Twist Divided by Mean Twist. Moment.	Cube Root of the Ratio.
Single-crank expansive . . . . .	0.2	2.625	1.38
“ “ . . . . .	0.4	2.125	1.29
“ “ . . . . .	0.6	1.835	1.22
“ “ . . . . .	0.8	1.698	1.20
Two-cylinder expansive, cranks at 90° . . . . .	0.2	1.616	1.17
“ “ “ . . . . .	0.3	1.415	1.12
“ “ “ . . . . .	0.4	1.298	1.09
“ “ “ . . . . .	0.5	1.256	1.08
“ “ “ . . . . .	0.6	1.270	1.08
“ “ “ . . . . .	0.7	1.329	1.10
“ “ “ . . . . .	0.8	1.357	1.11
Three-cylinder compound, cranks 120° . . . . .	h.p. 0.5, l.p. 0.66	1.40	1.12
Three-cylinder compound, l.p. cranks opposite one another, and h.p. midway }	“ “	1.26	1.08

For the engines we are considering it will be a very liberal allowance for ratio of maximum to mean twisting moment if we take it as equal to the ratio of the maximum to the mean pressure on the piston. The factor  $a$ , then, in the formula for diameter of the shaft will be multiplied by the cube

root of this ratio, or  $\sqrt[3]{\frac{100}{42}} = 1.34$ ,  $\sqrt[3]{\frac{100}{32.3}} = 1.45$ , and  $\sqrt[3]{\frac{100}{30}} = 1.49$

for the 10, 30, and 50-in. engines, respectively. Taking  $a = 3.5$ , which corresponds to a shearing strength of 60,000 and a factor of safety of 8 for

steel, or to 45,000 and a factor of 6 for iron, we have for the new coefficient  $a_1$  in the formula  $d_1 = a_1 \sqrt[3]{\text{I.H.P.} \div R}$ , the values 4.69, 5.08, and 5.22 from which we obtain the diameters of shafts of the six engines as follows:

Engine No.	1	2	3	4	5	6
Diam. of cyl.	10	10	30	30	50	50
Horse-power, I.H.P.	50	50	450	450	1250	1250
Revs. per min., $R$	250	125	130	65	90	45
Diam. of shaft $d =$	2.74	3.46	7.67	9.70	12.55	15.82

These diameters are calculated for twisting only. When the shaft is also subjected to bending strain the calculation must be modified as below:

**Resistance to Bending.** — The strength of a circular-section shaft to resist bending is one-half of that to resist twisting. If  $B$  is the bending moment in inch-lbs., and  $d$  the diameter of the shaft in inches,

$$B = \frac{\pi d^3}{32} \times f; \text{ and } d = \sqrt[3]{\frac{B}{f}} \times 10.2;$$

$f$  is the safe strain per square inch of the material of which the shaft is composed, and its value may be taken as given above for twisting (Seaton).

**Equivalent Twisting Moment.** — When a shaft is subject to both twisting and bending simultaneously, the combined strain on any section of it may be measured by calculating what is called the *equivalent twisting moment*; that is, the two strains are so combined as to be treated as a twisting strain only of the same magnitude and the size of shaft calculated accordingly. Rankine gave the following solution of the combined action of the two strains.

If  $T$  = the twisting moment, and  $B$  = the bending moment on a section of a shaft, then the equivalent twisting moment  $T_1 = B + \sqrt{B^2 + T^2}$ .

The two principal strains vary throughout the revolution, and the maximum equivalent twisting moment can only be obtained accurately by a series of calculations of bending and twisting moments taken at fixed intervals, and from them constructing a curve of strains.

Considering the engines of our examples to have overhung cranks, the maximum bending moment resulting from the thrust of the connecting-rod on the crank-pin will take place when the engine is passing its centers (neglecting the effect of the inertia of the reciprocating parts), and it will be the product of the total pressure on the piston by the distance between two parallel lines passing through the centers of the crank-pin and of the shaft bearing, at right angles to their axes; which distance is equal to  $1/2$  length of crank-pin bearing + length of hub +  $1/2$  length of shaft-bearing + any clearance that may be allowed between the crank and the two bearings. For our six engines we may take this distance as equal to  $1/2$  length of crank-pin + thickness of crank-arm +  $1.5 \times$  the diameter of the shaft as already found by the calculation for twisting. The calculation of diameter is then as below:

Engine No.	1	2	3	4	5	6
Diam. of cyl., in....	10	10	30	30	50	50
Horse-power.....	50	50	450	450	1250	1250
Revs. per min....	250	125	130	65	90	45
Max. press. on pis, $P$	7,854	7,854	70,686	70,686	196,350	196,350
Leverage, * $L$ in....	6.32	7.94	22.20	26.00	36.80	42.25
Bd.mo. $PL = B$ in.-lb	49,637	62,361	1,569,222	1,837,836	7,225,680	8,295,788
Twist. mom. $T$ ....	47,124	94,248	1,060,290	2,120,580	4,712,400	9,424,800
Equiv. twist mom.						
$T_1 = B + \sqrt{B^2 + T^2}$						
(approx.).....	118,000	175,000	3,463,000	4,647,000	15,840,000	20,850,000

\* Leverage = distance between centers of crank-pin and shaft bearing =  $1/2 l + 2.25 d$ .

Having already found the diameters, on the assumption that the shafts were subjected to a twisting moment  $T$  only, we may find the diameter

for resisting combined bending and twisting by multiplying the diameters already found by the cube roots of the ratio  $T_1 \div T$ , or

Giving corrected diameters  $\hat{a}_1 =$ 

1.40	1.27	1.46	1.34	1.64	1.36
3.84	4.39	11.35	12.99	20.58	21.52

By plotting these results, using the diameters of the cylinders for abscissas and diameters of the shafts for ordinates, we find that for the long-stroke engines the results lie almost in a straight line expressed by the formula, diameter of shaft = 0.43 × diameter of cylinder; for the short-stroke engines the line is slightly curved, but does not diverge far from a straight line whose equation is, diameter of shaft = 0.4 diameter of cylinder. Using these two formulas, the diameters of the shafts will be 4.0, 4.3, 12.0, 12.9, 20.0, 21.5.

J. B. Stanwood, in *Engineering*, June 12, 1891, gives dimensions of shafts of Corliss engines in American practice for cylinders 10 to 30 in. diameter. The diameters range from  $4\frac{15}{16}$  to  $14\frac{15}{16}$ , following precisely the equation, diameter of shaft =  $\frac{1}{2}$  diameter of cylinder -  $\frac{1}{16}$  inch.

**Fly-wheel Shafts.** — Thus far we have considered the shaft as resisting the force of torsion and the bending moment produced by the pressure on the crank-pin. In the case of fly-wheel engines the shaft on the opposite side of the bearing from the crank-pin has to be designed with reference to the bending moment caused by the weight of the fly-wheel, the weight of the shaft itself, and the strain of the belt. For engines in which there is an outboard bearing, the weight of fly-wheel and shaft being supported by two bearings, the point of the shaft at which the bending moment is a maximum may be taken as the point midway between the two bearings or at the middle of the fly-wheel hub, and the amount of the moment is the product of the weight supported by one of the bearings into the distance from the center of that bearing to the middle point of the shaft. The shaft is thus to be treated as a beam supported at the ends and loaded in the middle. In the case of an overhung fly-wheel, the shaft having only one bearing, the point of maximum moment should be taken as the middle of the bearing, and its amount is very nearly the product of half the weight of the fly-wheel and the shaft into the distance of the middle of its hub from the middle of the bearing. The bending moment should be calculated and combined with the twisting moment as above shown, to obtain the equivalent twisting moment, and the diameter necessary at the point of maximum moment calculated therefrom.

In the case of our six engines we assume that the weights of the fly-wheels, together with the shaft, are double the weight of fly-wheel rim obtained from the formula  $W = 785,400 \frac{d^2s}{R^2D^2}$  (given under Fly-wheels);

that the shaft is supported by an outboard bearing, the distance between the two bearings being  $2\frac{1}{2}$ , 5, and 10 feet for the 10-in., 30-in., and 50-in. engines, respectively. The diameters of the fly-wheels are taken such that their rim velocity will be a little less than 6000 feet per minute.

Engine No.	1	2	3	4	5	6
Diam. of cyl., inches....	10	10	30	30	50	50
Diam. of fly-wheel, ft....	7.5	15	14.5	29	21	42
Revs. per min.....	250	125	130	65	90	45
Half wt. fly-wheel and shaft, lbs.....	268	536	5,968	11,936	26,384	52,769
Lever arm for maximum moment, in. ....	15	15	30	30	60	60
Maximum bending moment, in.-lbs.....	4020	8040	179,040	358,080	1,583,070	3,166,140

As these are very much less than the bending moments calculated from the pressures on the crank-pin, the diameters already found are sufficient for the diameter of the shaft at the fly-wheel hub.

In the case of engines with heavy band fly-wheels and with long fly-wheel shafts it is of the utmost importance to calculate the diameter of the shaft with reference to the bending moment due to the weight of the fly-wheel and the shaft.

B. H. Coffey (*Power*, October, 1892) gives the formula for combined bending and twisting resistance,  $T_1 = 0.196 d^3S$ , in which  $T_1 = B + \sqrt{B^2 + T^2}$ ;  $T$  being the maximum, not the mean twisting moment; and



finds empirical working values for 0.196  $S$  as below. He says: Four points should be considered in determining this value: First, the nature of the material; second, the manner of applying the loads, with shock or otherwise; third, the ratio of the bending moment to the torsional moment — the bending moment in a revolving shaft produces reversed strains in the material, which tend to rupture it; fourth, the size of the section. Inch for inch, large sections are weaker than small ones. He puts the dividing line between large and small sections at 10 in. diameter, and gives the following safe values of  $S \times 0.196$  for steel, wrought iron, and cast iron, for these conditions.

VALUE OF  $S \times 0.196$ .

Ratio.	Heavy Shafts with Shock.			Light Shafts with Shock. Heavy Shafts No Shock.			Light Shafts No Shock.		
	Steel.	Wro't Iron.	Cast Iron.	Steel.	Wro't Iron.	Cast Iron.	Steel.	Wro't Iron.	Cast Iron.
$B$ to $T$ .									
3 to 10 or less.....	1045	880	440	1566	1320	660	2090	1760	880
3 to 5 or less.....	941	785	393	1410	1179	589	1882	1570	785
1 to 1 or less.....	855	715	358	1281	1074	537	1710	1430	715
$B$ greater than $T$ ...	784	655	328	1176	984	492	1568	1310	655

Mr. Coffey gives as an example of improper dimensions the fly-wheel shaft of a 1500 H.P. engine at Willimantic, Conn., which broke while the engine was running at 425 H.P. The shaft was 17 ft. 5 in. long between centers of bearings, 18 in. diam. for 8 ft. in the middle, and 15 in. diam. for the remainder, including the bearings. It broke at the base of the fillet connecting the two large diameters, or  $56\frac{1}{2}$  in. from the center of the bearing. He calculates the mean torsional moment to be 446,654 inch-pounds, and the maximum at twice the mean; and the total weight on one bearing at 87,530 lbs., which, multiplied by  $56\frac{1}{2}$  in., gives 4,945,445 in.-lbs. bending moment at the fillet. Applying the formula  $T_1 = B + \sqrt{B^2 + T^2}$ , gives for equivalent twisting moment 9,971,045 in.-lbs. Substituting this value in the formula  $T_1 = 0.196 S d^3$  gives for  $S$  the shearing strain 15,070 lbs. per sq. in., or if the metal had a shearing strength of 45,000 lb., a factor of safety of only 3. Mr. Coffey considers that 6000 lb. is all that should be allowed for  $S$  under these circumstances. This would give  $d = 20.35$  in. If we take from Mr. Coffey's table a value of 0.196  $S = 1100$ , we obtain  $d^3 = 9000$  nearly, or  $d = 20.8$  in. instead of 15 in., the actual diameter.

**Length of Shaft-bearings.**—There is as great a difference of opinion among writers, and as great a variation in practice concerning length of journal-bearings, as there is concerning crank-pins. The length of a journal being determined from considerations of its heating, the observations concerning heating of crank-pins apply also to shaft-bearings, and the formulæ for length of crank-pins to avoid heating may also be used, using for the total load upon the bearing the resultant of all the pressures brought upon it, by the pressure on the crank, by the weight of the fly-wheel, and by the pull of the belt. After determining this pressure, however, we must resort to empirical values for the so-called constants of the formulæ, really variables, which depend on the power of the bearing to carry away heat, and upon the quantity of heat generated, which latter depends on the pressure, on the number of square feet of rubbing surface passed over in a minute, and upon the coefficient of friction. This coefficient is an exceedingly variable quantity, ranging from 0.01 or less with perfectly polished journals, having end-play, and lubricated by a pad or oil-bath, to 0.10 or more with ordinary oil-cup lubrication.

Thurston says that the maximum allowable mean intensity of pressure may be, for all cases, computed by his formula for journals,  $l = PV \div 60,000 d$ , or by Rankine's,  $l = P(V + 20) \div 44,800 d$ , in which  $P$  is the mean total pressure in pounds,  $V$  the velocity of rubbing surface in feet per minute, and  $d$  the diameter of the shaft in inches. It must be borne in mind, he says, that the friction work on the main bearing next the crank is the sum of that due the action of the piston on the pin and that due

that portion of the weight of wheel and shaft and of pull of the belt which is carried there. The outboard bearing carries practically only the latter two parts of the total. The crank-shaft journals will be made longer on one side, and perhaps shorter on the other, than that of the crank-pin, in proportion to the work falling upon each, i.e., to their respective products of mean total pressure, speed of rubbing surfaces, and coefficients of friction.

Unwin says: Journals running at 150 revolutions per minute are often only one diameter long. Fan shafts running 150 revolutions per minute have journals six or eight diameters long. The ordinary empirical mode of proportioning the length of journals is to make the length proportional to the diameter, and to make the ratio of length to diameter increase with the speed. For wrought-iron journals:

Revs. per min. = 50 100 150 200 250 500 1000  $l/d = 0.004 R + 1$ .  
 Length ÷ diam. = 1.2 1.4 1.6 1.8 2.0 3.0 5.0.

Cast-iron journals may have  $l \div d = 9/10$ , and steel journals  $l \div d = 11/4$ , of the above values.

Unwin gives the following, calculated from the formula  $l = 0.4 \text{ H.P.} \div r$ , in which  $r$  is the crank radius in inches, and H.P. the horse-power transmitted to the crank-pin.

THEORETICAL JOURNAL LENGTH IN INCHES.

Load on Journal in Pounds.	Revolutions of Journal per minute.					
	50	100	200	300	500	1000
1,000	0.2	0.4	0.8	1.2	2.	4.
2,000	0.4	0.8	1.6	2.4	4.	8.
4,000	0.8	1.6	3.2	4.8	8.	16.
5,000	1.0	2.	4.	6.	10.	20.
10,000	2.	4.	8.	12.	20.	40.
15,000	3.	6.	12.	18.	30.	.....
20,000	4.	8.	16.	24.	40.	.....
30,000	6.	12.	24.	36.	.....	.....
40,000	8.	16.	32.	.....	.....	.....
50,000	10.	20.	40.	.....	.....	.....

Applying six different formulæ to our six engines, we have:

Engine No. ....	1	2	3	4	5	6
Diam. cyl. ....	10	10	30	30	50	50
Horse-power. ....	50	50	450	450	1,250	1,250
Revs. per min. ....	250	125	130	65	90	45
Mean pressure on crank-pin = $S$ ....	3,299	3,299	23,185	23,185	58,905	58,905
Half wt. of fly-wheel and shaft = $Q$ ....	268	536	5,968	11,936	26,470	52,940
Resultant pressure on bearing $\sqrt{Q^2 + S^2} = R_1$ .	3,310	3,335	23,924	26,194	64,580	79,200
Diam. of shaft journal. ....	3.84	4.39	11.35	12.99	20.58	21.52
Length of shaft journal:						
Marks, $l = 0.0000325 f R_1 N (f = 0.10)$	5.38	2.71	20.87	11.07	37.78	23.17
Whitham, $l = 0.0000515 f R_1 R (f = 0.10)$	4.27	2.15	16.53	8.77	29.95	18.35
Thurston, $l = P V \div (60,000 d)$ ....	3.61	1.82	14.00	7.43	25.36	15.55
Rankine, $l = P (V + 20) \div (44,800 d)$ ...	5.22	2.78	21.70	10.85	35.16	22.47
Unwin, $l = (0.004 R + 1) d$ ....	7.68	6.59	17.25	16.36	27.99	25.39
Unwin, $l = 0.4 \text{ H.P.} \div r$ ....	3.33	1.60	12.00	6.00	20.83	10.42
Average. ....	4.92	2.99	17.05	10.00	29.54	19.22

If we divide the mean resultant pressure on the bearing by the projected area, that is, by the product of the diameter and length of the journal, using the greatest and smallest lengths out of the seven lengths

for each journal given above, we obtain the pressure per square inch upon the bearing, as follows:

Engine No. ....	1	2	3	4	5	6
Press. per sq. in., shortest journal....	259	455	176	336	151	353
Longest journal.....	112	115	97	123	83	145
Average journal.....	175	254	124	202	106	191
Journal of length = diam.....	.....	173	.....	155	.....	175

Many of the formulæ give for the long-stroke engines a length of journal less than the diameter, but such short journals are rarely used in practice. The last line in the above table has been calculated on the supposition that the journals of the long-stroke engines are made of a length equal to the diameter.

In the dimensions of Corliss engines given by J. B. Stanwood (*Eng.*, June 12, 1891), the lengths of the journals for engines of diam. of cyl. 10 to 20 in. are the same as the diam. of the cylinder, and a little more than twice the diam. of the journal. For engines above 20 in. diam. of cyl. the ratio of length to diam. is decreased so that an engine of 30 in. diam. has a journal 26 in. long, its diameter being  $14\frac{15}{16}$  in. These lengths of journal are greater than those given by any of the formulæ above quoted.

There thus appears to be a hopeless confusion in the various formulæ for length of shaft journals, but this is no more than is to be expected from the variation in the coefficient of friction, and in the heat-conducting power of journals in actual use, the coefficient varying from 0.10 (or even 0.16 as given by Marks) down to 0.01, according to the condition of the bearing surfaces and the efficiency of lubrication. Thurston's

formula,  $l = \frac{PV}{60,000d}$ , reduces to the form  $l = 0.000004363 PR$ , in which

$P$  = mean total load on journal, and  $R$  = revolutions per minute. This is of the same form as Marks's and Whitham's formulæ, in which, if  $f$ , the coefficient of friction, be taken at 0.10, the coefficients of  $PR$  are, respectively, 0.0000065 and 0.00000515. Taking the mean of these three formulæ, we have  $l = 0.0000053 PR$ , if  $f = 0.10$  or  $l = 0.000053 fPR$  for any other value of  $f$ . The author believes this to be as safe a formula as any for length of journals, with the limitation that if it brings a result of length of journal less than the diameter, then the length should be made equal to the diameter. Whenever, with  $f = 0.10$  it gives a length which is inconvenient or impossible of construction on account of limited space, then provision should be made to reduce the value of the coefficient of friction below 0.10 by means of forced lubrication, end play, etc., and to carry away the heat, as by water-cooled journal-boxes. The value of  $P$  should be taken as the resultant of the mean pressure on the crank, and the load brought on the bearing by the weight of the shaft, fly-wheel, etc., as calculated by the formula already given, viz.,  $R_1 = \sqrt{Q^2 + S^2}$  for horizontal engines, and  $R_1 = Q + S$  for vertical engines.

For our six engines the formula  $l = 0.0000053 PR$  gives, with the limitation for the long-stroke engines that the length shall not be less than the diameter, the following:

Engine No. ....	1	2	3	4	5	6
Length of journal.....	4.39	4.39	16.48	12.99	30.80	21.52
Pressure per square inch on journal.....	196	173	128	155	102	171

**Crank-shafts with Center-crank and Double-crank Arms.**—In center-crank engines, one of the crank-arms, and its adjoining journal, called the after journal, usually transmit the power of the engine to the work to be done, and the journal resists both twisting and bending moments, while the other journal is subjected to bending moment only. For the after crank-journal the diameter should be calculated the same as for an overhung crank, using the formula for combined bending and twisting moment,  $T_1 = B + \sqrt{B^2 + T^2}$ , in which  $T_1$  is the equivalent twisting moment,  $B$  the bending moment, and  $T$  the twisting moment. This value of  $T_1$  is to be used in the formula, diameter =  $\sqrt[3]{5.1 T/S}$ . The



bending moment is taken as the maximum load on piston multiplied by one-fourth of the length of the crank-shaft between middle points of the two journal bearings, if the center is midway between the bearings, or by one-half the distance measured parallel to the shaft from the middle of the crank-pin to the middle of the after bearing. This supposes the crank-shaft to be a beam loaded at its middle and supported at the ends, but Whitham would make the bending moment only one-half of this, considering the shaft to be a beam secured or fixed at the ends, with a point of contraflexure one-fourth of the length from the end. The first supposition is the safer, but since the bending moment will in any case be much less than the twisting moment, the resulting diameter will be but little greater than if Whitham's supposition is used. For the forward journal, which is subjected to bending moment only, diameter of shaft =  $\sqrt[3]{10.2 B/S}$ , in which  $B$  is the maximum bending moment and  $S$  the safe shearing strength of the metal per square inch.

For our six engines, assuming them to be center-crank engines, and considering the crank-shaft to be a beam supported at the ends and loaded in the middle, and assuming lengths between centers of shaft bearings as given below, we have:

Engine No. ....	1	2	3	4	5	6
Length of shaft, assumed, in., $L$ ..	20	24	48	60	76	96
Max. press. on crank-pin, $P$ ....	7,854	7,854	70,686	70,686	196,350	196,350
Max. bending moment, $B = 1/4 PL$ ,	39,270	49,637	848,232	1,060,290	3,729,750	4,712,400
Twisting mom., $T$	47,124	94,248	1,060,290	2,120,580	4,712,400	9,424,800
Equiv. twist. mom.						
$B + \sqrt{B^2 + T^2}$ ...	101,000	156,000	2,208,000	3,430,000	9,740,000	15,240,000
Diam. of after jour.						
$d = \sqrt[3]{\frac{5.1 T_1}{8000}}$ ...	3.98	4.60	11.15	13.00	18.25	21.20
Diam. of forw. jour.,						
$d_1 = \sqrt[3]{\frac{10.2 B}{8000}}$ ...	3.68	3.99	10.28	11.16	16.82	18.18

The lengths of the journals would be calculated in the same manner as in the case of overhung cranks, by the formula  $l = 0.000053 fPR$ , in which  $P$  is the resultant of the mean pressure due to pressure of steam on the piston, and the load of the fly-wheel, shaft, etc., on each of the two bearings. Unless the pressures are equally divided between the two bearings, the calculated lengths of the two will be different; but it is usually customary to make them both of the same length, and in no case to make the length less than the diameter. The diameters also are usually made alike for the two journals, using the largest diameter found by calculation.

The crank-pin for a center crank should be of the same length as for an overhung crank, since the length is determined from considerations of heating, and not of strength. The diameter also will usually be the same, since it is made great enough to make the pressure per square inch on the projected area (product of length by diameter) small enough to allow of free lubrication, and the diameter so calculated will be greater than is required for strength.

**Crank-shaft with Two Cranks coupled at 90°.** — If the whole power of the engine is transmitted through the after journal of the after crank-shaft, the greatest twisting moment is equal to 1.414 times the maximum twisting moment due to the pressure on one of the crank-pins. If  $T$  = the maximum twisting moment produced by the steam-pressure on one of the pistons, then  $T_1$ , the maximum twisting moment on the after part of the crank-shaft, and on the line-shaft produced, when each crank makes an angle of 45° with the center line of the engine, is 1.414  $T$ . Substituting this value in the formula for diameter to resist simple torsion, viz.,  $d = \sqrt[3]{5.1 T \div S}$ , we have  $d = \sqrt[3]{5.1 \times 1.414 T \div S}$ , or

$d = 1.932 \sqrt[3]{T/S}$ , in which  $T$  is the maximum twisting moment produced by one of the pistons,  $d$  = diameter in inches, and  $S$  = safe working shearing strength of the material. For the forward journal of the after crank, and the after journal of the forward crank, the torsional moment is that due to the pressure of steam on the forward piston only, and for the forward journal of the forward crank, if none of the power of the engine is transmitted through it, the torsional moment is zero, and its diameter is to be calculated for bending moment only.

**For Combined Torsion and Flexure.** — Let  $B_1$  = bending moment on either journal of the forward crank due to maximum pressure on forward piston,  $B_2$  = bending moment on either journal of the after crank due to maximum pressure on after piston,  $T_1$  = maximum twisting moment on after journal of forward crank, and  $T_2$  = maximum twisting moment on after journal of after crank, due to pressure on the after piston.

Then equivalent twisting moment on after journal of forward crank =  $B_1 + \sqrt{B_1^2 + T_1^2}$ .

On forward journal of after crank =  $B_2 + \sqrt{B_2^2 + T_1^2}$ .

On after journal of after crank =  $B_2 + \sqrt{B_2^2 + (T_1 + T_2)^2}$ .

These values of equivalent twisting moment are to be used in the formula for diameter of journals  $d = \sqrt[3]{5.1 T/S}$ . For the forward journal of the forward crank-shaft  $d = \sqrt[3]{10.2 B_1/S}$ .

It is customary to make the two journals of the forward crank of one diameter, viz., that calculated for the after journal.

**For a Three-cylinder Engine** with cranks at  $120^\circ$ , the greatest twisting moment on the after part of the shaft, if the maximum pressures on the three pistons are equal, is equal to twice the maximum pressure on any one piston, and it takes place when two of the cranks make angles of  $30^\circ$  with the center line, the third crank being at right angles to it. (For demonstration, see Whitham's "Steam-engine Design," p. 252.) For combined torsion and flexure the same method as above given for two crank engines is adopted for the first two cranks; and for the third, or after crank, if all the power of the three cylinders is transmitted through it, we have the equivalent twisting moment on the forward

journal =  $B_3 + \sqrt{B_3^2 + (T_1 + T_2)^2}$ , and on the after journal =  $B_3 + \sqrt{B_3^2 + (T_1 + T_2 + T_3)^2}$ ,  $B_3$  and  $T_3$  being respectively the bending and twisting moments due to the pressure on the third piston.

**Crank-shafts for Triple-expansion Marine Engines**, according to an article in *The Engineer*, April 25, 1890, should be made larger than the formulæ would call for, in order to provide for the stresses due to the racing of the propeller in a sea-way, which can scarcely be calculated. A kind of unwritten law has sprung up for fixing the size of a crank-shaft, according to which the diameter of the shaft is made about  $0.45 D$ , where  $D$  is the diameter of the high-pressure cylinder. This is for solid shafts. When the speeds are high, as in war-ships, and the stroke short, the formula becomes  $0.4 D$ , even for hollow shafts.

**The Valve-stem or Valve-rod.** — The valve-rod should be designed to move the valve under the most unfavorable conditions, which are when the stem acts by thrusting, as a long column, when the valve is unbalanced (a balanced valve may become unbalanced by the joint leaking) and when it is imperfectly lubricated. The load on the valve is the product of the area into the greatest unbalanced pressure upon it per square inch, and the coefficient of friction may be as high as 20%. The product of this coefficient and the load is the force necessary to move the valve, which equals the maximum thrust on the valve-rod. From this force the diameter of the valve-rod may be calculated by the usual formula for columns. An empirical formula given by Seaton is: Diam. of rod =  $d = \sqrt{lp/F}$ , in which  $l$  = length, and  $b$  = breadth of valve, in inches;  $p$  = maximum absolute pressure on the valve in lb. per sq. in., and  $F$  a coefficient whose values are, for iron: long rod 10,000, short 12,000; for steel: long rod 12,000, short 14,500.

Whitham gives the short empirical rule: Diam. of valve-rod =  $1/30$  diam. of cyl. =  $1/3$  diam. of piston-rod.

**The Eccentric.**—Diam. of eccentric-sheave =  $2.4 \times$  throw of eccentric +  $1.2 \times$  diam. of shaft.  $D$  = diam. of valve rod (Seaton).

- Breadth of the sheave at the shaft..... =  $1.15 \times D + 0.65$  in.
- Breadth of the sheave at the strap..... =  $D + 0.6$  in.
- Thickness of metal around the shaft.... =  $0.7 \times D + 0.5$  in.
- Thickness of metal at circumference... =  $0.6 \times D + 0.4$  in.
- Breadth of key..... =  $0.7 \times D + 0.5$  in.
- Thickness of key..... =  $0.25 \times D + 0.5$  in.
- Diam. of bolts connecting parts of strap. =  $0.6 \times D + 0.1$  in.

THICKNESS OF ECCENTRIC-STRAP.

When of bronze or malleable cast iron:

- Thickness of eccentric-strap at the middle... =  $0.4 \times D + 0.6$  in.
- Thickness of eccentric-strap at the sides..... =  $0.3 \times D + 0.5$  in.

When of wrought iron or cast steel:

- Thickness of eccentric-strap at the middle... =  $0.4 \times D + 0.5$  in.
- Thickness of eccentric-strap at the sides..... =  $0.27 \times D + 0.4$  in.

**The Eccentric-rod.**—The diameter of the eccentric-rod in the body and at the eccentric end may be calculated in the same way as that of the connecting-rod, the length being taken from center of strap to center of pin. Diameter at the link end =  $0.8 D + 0.2$  in.

This is for wrought iron; no reduction in size should be made for steel. Eccentric-rods are often made of rectangular section.

**Reversing-gear** should be so designed as to have more than sufficient strength to withstand the strain of both the valves and their gear at the same time under the most unfavorable circumstances; it will then have the stiffness requisite for good working.

Assuming the work done in reversing the link-motion,  $W$ , to be only that due to overcoming the friction of the valves themselves through their whole travel, then, if  $T$  be the travel of valves in inches, for a compound engine

$$W = \frac{T}{12} \left( \frac{l \times b \times p}{5} \right) + \frac{T}{12} \left( \frac{l_1 \times b_1 \times p_1}{5} \right);$$

$l_1$ ,  $b_1$ , and  $p_1$  being length, breadth, and maximum steam-pressure on valve of the second cylinder; and for an expansive engine

$$W = 2 \times \frac{T}{12} \left( \frac{l \times b \times p}{5} \right); \text{ or } \frac{T}{30} (l \times b \times p).$$

To provide for the friction of link-motion, eccentrics, and other gear, and for abnormal conditions of the same, take the work at one and a half times the above amount.

To find the strain at any part of the gear having motion when reversing, divide the work so found by the space moved through by that part in feet; the quotient is the strain in pounds; the size may be found from the ordinary rules of construction for any of the parts of the gear. (Seaton.)

**Current Practice in Engine Proportions, 1897.** (Compare pages 1021 to 1039.)—A paper with this title by Prof. John H. Barr, in *Trans. A. S. M. E.*, xviii, 737, gives the results of an examination of the proportions of parts of a great number of single-cylinder engines made by different builders. The engines classed as low speed (L. S.) are Corliss or other long-stroke engines usually making not more than 100 or 125 revs. per min. Those classed as high speed (H. S.) have a stroke generally of 1 to  $1\frac{1}{2}$  diameters and a speed of 200 to 300 revs. per min. The results are expressed in formulas of rational form with empirical coefficients, and are here abridged as follows (dimensions in inches):

*Thickness of Shell*, L. S. only. —  $t = CD + B$ ;  $D$  = diam. of piston in in.;  $B = 0.3$  in.;  $C$  varies from 0.04 to 0.06, mean = 0.05.

*Flanges and Cylinder-heads.* —  $1$  to  $1.5 \times$  thickness of shell, mean  $1.2$ .

*Cylinder-head Studs.* — No studs less than  $\frac{3}{4}$  in. nor greater than  $1\frac{3}{8}$  in. diam. Least number, 8, for 10 in. diam. Average number =  $0.7 D$ . Average diam. =  $D/40 + \frac{1}{2}$  in.

*Ports and Pipes.* —  $a$  = area of port (or pipe) in sq. in.;  $A$  = area of piston, sq. in.;  $V$  = mean piston-speed, ft. per min.;  $a = AV/C$ , in which  $C$  = mean velocity of steam through the port or pipe in ft. per min.



*Ports*, H. S. (same ports for steam as for exhaust). —  $C = 4500$  to  $6500$ , mean  $5500$ . For ordinary piston-speed of  $600$  ft. per min.  $a = KA$ ;  $K = 0.09$  to  $0.13$ , mean  $0.11$ .

*Steam-ports*, L. S. —  $C = 5000$  to  $9000$ , mean  $6800$ ;  $K = 0.08$  to  $0.10$ , mean  $0.09$ .

*Exhaust-ports*, L. S. —  $C = 4000$  to  $7000$ , mean  $5500$ ;  $K = 0.10$  to  $0.125$ , mean  $0.11$ .

*Steam-pipes*, H. S. —  $C = 5800$  to  $7000$ , mean  $6500$ . If  $d =$  diam. of pipe and  $D =$  diam. of piston,  $d = 0.29 D$  to  $0.32 D$ , mean  $0.30 D$ .

*Steam-pipes*, L. S. —  $C = 5000$  to  $8000$ , mean  $6000$ ;  $d = 0.27$  to  $0.35 D$ ; mean  $0.32 D$ .

*Exhaust-pipes*, H. S. —  $C = 2500$  to  $5500$ , mean  $4400$ ;  $d = 0.33$  to  $0.50 D$ , mean  $0.37 D$ .

*Exhaust-pipes*, L. S. —  $C = 2800$  to  $4700$ , mean  $3800$ ;  $d = 0.35$  to  $0.45 D$ , mean  $0.40 D$ .

*Face of Pistons*. —  $F =$  face;  $D =$  diameter.  $F = CD$ . H. S.:  $C = 0.30$  to  $0.60$ , mean  $0.46$ . L. S.:  $C = 0.25$  to  $0.45$ , mean  $0.32$ .

*Piston-rods*. —  $d =$  diam. of rod;  $D =$  diam. of piston;  $L =$  stroke, in.:  $d = C \sqrt{DL}$ . H. S.:  $C = 0.12$  to  $0.175$ , mean  $0.145$ . L. S.:  $C = 0.10$  to  $0.13$ , mean  $0.11$ .

*Connecting-rods*. — H. S. (generally  $6$  cranks long, rectangular section):  $b =$  breadth;  $h =$  height of section;  $L_1 =$  length of connecting-rod;  $D =$  diam. of piston;  $b = C \sqrt{DL_1}$ ;  $C = 0.045$  to  $0.07$ , mean  $0.057$ ;  $h = Kb$ ;  $K = 2.2$  to  $4$ , mean  $2.7$ . L. S. (generally  $5$  cranks long, circular sections only):  $C = 0.082$  to  $0.105$ , mean  $0.092$ .

*Cross-head Slides*. — Maximum pressure in lbs. per sq. in. of shoe, due to the vertical component of the force on the connecting-rod. H. S.:  $10.5$  to  $38$ , mean  $27$ . L. S.:  $29$  to  $58$ , mean  $40$ .

*Cross-head Pins*. —  $l =$  length;  $d =$  diam.; projected area  $= a = dl = CA$ ;  $A =$  area of piston;  $l = Kd$ . H. S.:  $C = 0.06$  to  $0.11$ , mean  $0.08$ ;  $K = 1$  to  $2$ , mean  $1.25$ . L. S.:  $C = 0.054$  to  $0.10$ , mean  $0.07$ ;  $K = 1$  to  $1.5$ , mean  $1.3$ .

*Crank-pin*. — H.P. = horse-power of engine;  $L =$  length of stroke;  $l =$  length of pin;  $l = C \times \text{H.P.} / (L + B)$ ;  $d =$  diam. of pin;  $A =$  area of piston;  $dl = KA$ . H. S.:  $C = 0.13$  to  $0.46$ , mean  $0.30$ ;  $B = 2.5$  in.;  $K = 0.17$  to  $0.44$ , mean  $0.24$ . L. S.:  $C = 0.4$  to  $0.8$ , mean  $0.6$ ;  $B = 2$  in.;  $K = 0.065$  to  $0.115$ , mean  $0.09$ .

*Crank-shaft Main Journal*. —  $d = C \sqrt[3]{\text{H.P.} \div N}$ ;  $d =$  diam.;  $l =$  length;  $N =$  revs. per min.; projected area  $= MA$ ;  $A =$  area of piston. H. S.:  $C = 6.5$  to  $8.5$ , mean  $7.3$ ;  $l = Kd$ ;  $K = 2$  to  $3$ , mean  $2.2$ ;  $M = 0.37$  to  $0.70$ , mean  $0.46$ . L. S.:  $C = 6$  to  $8$ , mean  $6.8$ ;  $K = 1.7$  to  $2.1$ , mean  $1.9$ ;  $M = 0.46$  to  $0.64$ , mean  $0.56$ .

*Piston-speed*. — H. S.:  $530$  to  $660$ , mean  $600$ ; L. S.:  $500$  to  $850$ , mean  $600$ .

*Weight of Reciprocating Parts* (piston, piston-rod, cross-head, and one-half of connecting-rod). —  $W = CD^2 \div LN^2$ ;  $D =$  diam. of piston;  $L =$  length of stroke, in.;  $N =$  revs. per min. H. S. only:  $C = 1,200,000$  to  $2,300,000$ , mean  $1,860,000$ .

*Belt-surface* per I.H.P. —  $S = C \times \text{H.P.} + B$ ;  $S =$  product of width of belt in feet by velocity of belt in ft. per min. H. S.:  $C = 21$  to  $40$ , mean  $28$ ;  $B = 1800$ . L. S.:  $S = C \times \text{H.P.}$ ,  $C = 30$  to  $42$ , mean  $= 35$ .

*Fly-wheel* (H. S. only). — Weight of rim in lbs.:  $W = C \times \text{H.P.} \div D_1^2 N^3$ ;  $D_1 =$  diam. of wheel in in.;  $C = 65 \times 10^{10}$  to  $2 \times 10^{12}$  mean  $= 12 \times 10^{11}$ , or  $1,200,000,000,000$ .

*Weight of Engine* per I.H.P. in lbs., including fly-wheel. —  $W = C \times \text{H.P.}$ . H. S.:  $C = 100$  to  $135$ , mean  $115$ . L. S.:  $C = 135$  to  $240$ , mean  $175$ .

**Current Practice in Steam-engine Design, 1909.** (Ole N. Troien, *Bull. Univ'y of Wis.*, No. 252; *Am. Mach.*, April 22, 1909.) — Practice in proportioning standard steam-engine parts has settled down to certain definite values, which have by long usage been found to give satisfactory results. These values can readily be expressed in formulas showing the relation between the more important factors entering the problem of design.

These formulæ may be considered as partly rational and partly em-

pirical; rational in the sense that the variables enter in the same manner as in a strict analysis, and empirical in the sense that the constants, instead of being obtained from assumed working strength, bearing pressures etc., are derived from actual practice and include elements whose values are not accurately known but which have been found safe and economical.

The following symbols of notation are used in the formulas given:

$D$  = diameter of piston.  $A$  = area of piston.  $L$  = length of stroke.  
 $p$  = unit steam pressure, taken as 125 lbs. per sq. in. above exhaust as a standard pressure. H.P. = rated horse-power.  $N$  = revs. per min.  
 $C$  and  $K$ , constants, and  $d$  = diam. and  $l$  = length of unit under consideration. All dimensions in inches.

The commercial point of cut-off is taken at  $1/4$  of the stroke. H. S., high-speed engines. L. S., low-speed, or long-stroke engines.

*Piston Rod.* —  $d = C \sqrt{DL}$ . H. S.:  $C = 0.15$  (min., 0.125; max., 0.187); L. S.:  $C = 0.114$  (min., 0.1; max., 0.156).

*Cylinder.* — Thickness of wall in ins. =  $CD + 0.28$ .  $C = 0.054$  (min., 0.035; max., 0.072). Clearance volume 5 to 11% for H. S. engines, and from 2 to 5% for Corliss engines.

*Stud Bolts.* — Number =  $0.72 D$  for H. S. (0.65  $D$  for Corliss.) Diam. in ins. =  $0.04 D + 0.375$ .

*Ratio (C) of Stroke to Cylinder Diameter (L/D).* — For  $N > 200$ ,  $C = 1.07$  (min., 0.82; max., 1.55); for  $N = 110$  to 200,  $C = 136$  (min., 1.03; max., 1.88); for  $N < 110$  (Corliss engines),  $C = (L - 8)/D = 1.63$  (min., 1.15; max., 2.4).

*Piston.* — Width of face in ins. =  $CD + 1$ . Mean value of  $C = 0.32$  for H. S. (0.26 for Corliss). Thickness of shell = thickness of cylinder wall  $\times 0.6$  (0.7 for Corliss).

*Piston Speeds.* — H. S., 605 ft. per min. (min. 320; max., 920); Corliss, 592 ft. per min. (min., 400; max., 800).

*Cross-head.* — Area of shoes in sq. ins. =  $0.53 A$  (min., 0.37; max., 0.72).

*Cross-head Pin.* — Diameter =  $0.25 D$  (min., 0.17; max., 0.28). Length for H. S. = diam.  $\times 1.25$  (min., 1; max., 1.5); for Corliss = diam.  $\times 1.43$  (min., 1; max., 1.9).

*Connecting-rods.* — Breadth for H. S. =  $0.073 \sqrt{L_c D}$  (min., 0.55; max., 0.094). Height = breadth  $\times 2.28$  (min., 1.85; max., 3). For L. S., diam. of circular rod =  $0.092 \sqrt{L_c D}$  (min., 0.081; max., 0.104).  $L_c$  = length center to center of bearings.

*Crank-pin.* — Diam. for H. S. center-crank engines =  $0.4 D$  (min., 0.28; max., 0.526). Diam. for side-crank Corliss =  $0.27 D$  (min., 0.21; max., 0.32). Length for H. S. = diam.  $\times 0.87$  (min., 0.66; max., 1.25). Length for Corliss = diam.  $\times 1.14$  (min., 1; max., 1.3).

*Main Journals of Crank-shaft.* — For H. S. center-crank engines, diam. =  $6.6 \sqrt[3]{H.P./N}$  (min., 5.4; max., 8.2). For Corliss, diameter =  $7.2 \sqrt[3]{(H.P./N) - 0.3}$  (min., 6.4; max., 8).

*Fly-wheels.* — Total weight in pounds for H. S. up to 175 H.P. =  $1,300,000,000 H.P./D_1^2 N^3$ , where  $D_1$  = diam. of wheel in ins. (min., 660,000,000,000; max., 2,800,000,000,000). For larger H. S. engines, weight =  $(C \times H.P./D_1^2 N^3) + 1000$ , where  $C = 720,000,000,000$  (min., 330,000,000,000; max., 1,140,000,000,000). For Corliss engines, weight =  $(C \times H.P./D_1^2 N^3) - K$ , where  $C = 890,000,000,000$  (min., 625,000,000,000; max., 1,330,000,000,000), and  $K = 4000$  (min., 2,800; max., 6000). Diam. in ins. =  $4.4 \times$  length of stroke.

*Belt Surface per I.H.P.* — Square feet of belt surface per minute ( $S$ ) for H. S. =  $H.P. \times 26.5$  (min., 10; max., 55). For Corliss engines,  $S = 1000 + (21 \times H.P.)$  (min., 18.2; max., 35).

*Velocity of Wheel Rim.* — For H. S. 70 ft. per sec. (min., 48; max., 70); for Corliss, 68 ft. per sec. (min., 40; max., 68).

*Weight of Reciprocating Parts* (Piston + piston rod + crosshead +  $1/2$  connecting-rod). — Weight in lbs.  $W = (D^2/LN^2) \times 2,000,000$  (min., 1,370,000; max., 3,400,000). Balance weight opposite crank-pin =  $0.75 W$ .

*Weight of engine per I.H.P.* — Lbs. per I.H.P. for belt-connected H. S.

engines = H.P.  $\times$  82 (min., 52; max., 120). Do., for Corliss = H.P.  $\times$  132 (min., 102; max., 164).

**Shafts and Bearings of Engines.** (James Christie, *Proc. Engrs. Club of Phila.*, 1898.) — The dimensions are determined by two independent considerations: 1. Sufficient size to prevent excessive deflection or torsional yield. 2. To provide sufficient wearing surface; to prevent excessive wear of journals. Usually, when the first condition is preserved, the other is provided for. When the bearings are flexible, — and excessive deflection within the limit of ordinary safety affects nothing external to the bearings, — considerable deflection can be tolerated. When bearings are rigid, or deflection may derange external mechanism, — for example, an overhung crank, — then the deflection must be more restricted. The effect of deflection is to concentrate pressure on the ends of journals, rendering the apparent bearing surface inefficient.

In direct-driven electric generators a deflection of 0.01 in. per foot of length has caused much trouble from hot bearings. I have proportioned such shafts so that the deflection will not exceed one-half this extent.

In some shafts, especially those having an oscillating movement, torsional elasticity is a prime consideration, and the limits can be known only by experience. Reuleaux says: "Limit the torsional yield to 0.1 degree per foot of length." This in some cases can be readily tolerated; in others, it has proved excessive. I have adopted the following as a general guide: Permissible twist per foot of length = 0.10 degree for easy service, without severe fluctuation of load; 0.075 degree for fluctuating loads suddenly applied; 0.050 degree for loads suddenly reversed.

Sufficiency of wearing surface and the limitation of pressure per unit of surface are determined by several conditions: 1. Speed of movement. 2. Character of material. 3. Permissible wear of journals or bearings. 4. Constancy of pressure in one direction. 5. Alternation of the direction of pressure.

Taking the product of pressure per sq. in. of surface in lbs., and speed of movement in ft. per min., we obtain a quantity, which we can term the permissible foot-pounds per minute for each sq. in. of wearing surface. This product varies in good practice under various conditions from 50,000 to 500,000 ft.-lbs. per min. For instance, good practice, in later years, has largely increased the area of crosshead slide surfaces. For crossheads having maximum speed of 1000 feet per minute, the pressure per inch of wearing surface should not exceed 50 pounds, giving 50,000 ft.-lbs. per min.; whereas crank-pins of the requisite grade of steel, with good lining metal in the boxes and efficient lubrication, will endure 200,000 ft.-lbs. per min. satisfactorily, and more than double this when speeds are very high and the pressure intermittent. On main shafts, with pressures constant in one direction, it is advisable not to exceed 50,000 ft.-lbs. per min. for heavily loaded shafts at low velocity. This may be increased to 100,000 for lighter loads and higher velocities. It can be inferred, therefore, that the product of speed and pressure cannot be used, in any comprehensive way, as a rational basis for proportioning wearing surfaces. The pressure per unit of surface must be reduced as the speed is increased, but not in a constant ratio. A good example of journals severely tested are the recent 110,000-pound freight cars, which bear a pressure of 400 lbs. per sq. in. of journal bearing, and at a speed of ten miles per hour make about 60,000 foot-pounds per minute.

**Calculating the Dimensions of Bearings.** (F. E. Cardullo, *Mach'y*, Feb., 1907.) — The durability of the lubricating film is affected in great measure by the character of the load that the bearing carries. When the load is unvarying in amount and direction, as in the case of a shaft carrying a heavy bandwheel, the film is easily ruptured. In those cases where the pressure is variable in amount and direction, as in railway journals and crank-pins, the film is much more durable. When the journal only rotates through a small arc, as with the wrist-pin of a steam-engine, the circumstances are most favorable. It has been found that when all other circumstances are exactly similar, a car journal will stand about twice the unit pressure that a fly-wheel journal will. A crank-pin, since the load completely reverses every revolution, will stand three times, and a wrist-pin will stand four times the unit pressure that the fly-wheel journal will.



The amount of pressure that commercial oils will endure at low speeds without breaking down varies from 500 to 1000 lbs. per sq. in., where the load is steady. It is not safe, however, to load a bearing to this extent, since it is only under favorable circumstances that the film will stand this pressure without rupturing. On this account, journal bearings should not be required to stand more than two-thirds of this pressure at slow speeds, and the pressure should be reduced when the speed increases. The approximate unit pressure which a bearing will endure without seizing is  $p = PK \div (DN + K)$  (1).  $p$  = allowable pressure in lbs. per sq. in. of projected area,  $D$  = diam. of the bearing in ins.,  $N$  = r.p.m. and  $P$  and  $K$  depend upon the kind of oil, manner of lubrication, etc.

$P$  is the maximum safe unit pressure for the given circumstances, at a very slow speed. In ordinary cases, its value is 200 for collar thrust bearings, 400 for shaft bearings, 800 for car journals, 1200 for crank-pins, and 1600 for wrist-pins. In exceptional circumstances, these values may be increased by as much as 50%, but only when the workmanship is of the best, the care the most skillful, the bearing readily accessible, and the oil of the best quality, and unusually viscous. In the great units of the Subway power plant in New York, the value of  $P$  for the crank-pins is 2000.

The factor  $K$  depends upon the method of oiling, the rapidity of cooling, and the care which the journal is likely to get. It will have about the following values: Ordinary work, drop-feed lubrication, 700; first-class care, drop-feed lubrication, 1000; force-feed lubrication or ring-oiling, 1200 to 1500; extreme limit for perfect lubrication and air-cooled bearings, 2000. The value 2000 is seldom used, except in locomotive work where the rapid circulation of the air cools the journals. Higher values than this may only be used in the case of water-cooled bearings.

In case the bearing is some form of a sliding shoe, the quantity  $240 V$  should be substituted for the quantity  $DN$ ,  $V$  being the velocity of rubbing in feet per second. There are a few cases where a unit pressure sufficient to break down the oil film is allowable, such as the pins of punching and shearing machines, pivots of swing bridges, etc.

In general, the diameter of a shaft or pin is fixed from considerations of strength or stiffness. Having obtained the proper diameter, we must next make the bearing long enough so that the unit pressure shall not exceed the required value. This length may be found by the equation:

$$L = (W + PK) \times (N + K/D), \dots \dots (2)$$

where  $L$  is the length of the bearing in ins.,  $W$  the load upon it in lbs., and  $P$ ,  $K$ ,  $N$ , and  $D$  are as before.

A bearing may give poor satisfaction because it is too long, as well as because it is too short. Almost every bearing is in the condition of a loaded beam, and therefore it has some deflection.

Shafts and crank-pins must not be made so long that they will allow the load to concentrate at any point. A good rule for the length is to make the ratio of length to diameter about equal to  $1/8 \sqrt{N}$ . This quantity may be diminished by from 10 to 20% in the case of crank-pins and increased in the same proportion in the case of shaft bearings, but it is not wise to depart too far from it. In the case of an engine making 100 r.p.m., the bearings would be by this rule from  $1\frac{1}{4}$  to  $1\frac{1}{2}$  diams. in length. In the case of a motor running at 1000 r.p.m., the bearings would be about 4 diams. long.

The diameter of a shaft or pin must be such that it will be strong and stiff enough to do its work properly. In order to design it for strength and stiffness, it is first necessary to know its length. This may be assumed tentatively from the equation

$$L = 20 W \sqrt{N} + PK. \dots \dots (3)$$

The diameter may then be found by any of the standard equations for the strength of shafts or pins given in the different works on machine design. [See The Strength of the Crank-pin, page 1027.] The length is then recomputed from formula No. 2, taking this new value if it does not differ materially from the one first assumed. If it does, and especially if it is greater than the assumed length, take the mean value of the assumed and computed lengths, and try again.

EXAMPLE.—We will take the case of the crank-pin of an engine with a

20-in. cylinder, running at 80 r.p.m., and having a maximum unbalanced steam pressure of 100 lbs. per sq. in. The total steam load on the piston is 31,400 pounds.  $P$  is taken at 1200, and  $K$  as 1000. We will therefore obtain for our trial length:

$$L = (20 \times 31,400 \times \sqrt{80}) + (1200 \times 1000) = 4.7, \text{ or say } 4\frac{3}{4} \text{ ins.}$$

In order that the deflection of the pin shall not be sufficient to destroy the lubricating film we have

$$D = 0.09 \sqrt[4]{WL^3},$$

which limits the deflection to 0.003 in. This gives  $D = 3.85$  or say  $3\frac{7}{8}$  ins. With this diameter, formula No. 2 gives  $L = 8.9$ , say 9 ins.

The mean of this value and the one obtained before is about 7 ins. Substituting this in the equation for the diameter, we get  $5\frac{1}{4}$  ins. Substituting this new diameter in equation No. 2 we have  $L = 7.05$ , say 7 ins.

Probably most good designers would prefer to take about half an inch off the length of this pin, and add it to the diameter, making it  $5\frac{3}{4} \times 6\frac{1}{2}$  inches, and this will bring the ratio of the length to the diameter nearer to  $\frac{1}{8} \sqrt{N}$ .

**Engine-frames or Bed-plates.**—No definite rules for the design of engine-frames have been given by authors of works on the steam-engine. The proportions are left to the designer who uses "rule of thumb" or copies from existing engines. F. A. Halsey (*Am. Mach.*, Feb. 14, 1895) has made a comparison of proportions of the frames of horizontal Corliss engines of several builders. The method of comparison is to compute from the measurements the number of square inches in the smallest cross-section of the frame, that is, immediately behind the pillow block, also to compute the total maximum pressure upon the piston, and to divide the latter quantity by the former. The result gives the number of pounds pressure upon the piston allowed for each square inch of metal in the frame. He finds that the number of lbs. per sq. in. of smallest section of frame ranges from 217 for a  $10 \times 30$  in. engine up to 575 for a  $28 \times 48$  in. A  $30 \times 60$  in. engine shows 350 lbs., and a 32-in. engine which has been running for many years shows 667 lbs. Generally the strains increase with the size of the engine, and more cross-section of metal is allowed with relatively long strokes than with short ones.

From the above Mr. Halsey formulates the general rule that in engines of moderate speed, and having strokes up to  $1\frac{1}{2}$  times the diameter of the cylinder, the load per square inch of smallest section should be for a 10-in. engine 300 lbs., which figure should be increased for larger bores up to 500 lbs. for a 30-in. cylinder of the same relative stroke. For high speeds or for longer strokes the load per square inch should be reduced.

### FLY-WHEELS.

The function of a fly-wheel is to store up and to restore the periodical fluctuations of energy given to or taken from an engine or machine, and thus to keep approximately constant the velocity of rotation. Rankine

calls the quantity  $\frac{\Delta E}{2 E_0}$  the coefficient of fluctuation of speed or of unsteadiness, in which  $E_0$  is the mean actual energy, and  $\Delta E$  the excess of energy received or of work performed, above the mean, during a given interval. The ratio of the periodical excess or deficiency of energy  $\Delta E$  to the whole energy exerted in one period or revolution General Morin found to be from  $\frac{1}{6}$  to  $\frac{1}{4}$  for single-cylinder engines using expansion; the shorter the cut-off the higher the value. For a pair of engines with cranks coupled at  $90^\circ$  the value of the ratio is about  $\frac{1}{4}$ , and for three engines with cranks at  $120^\circ$ ,  $\frac{1}{12}$  of its value for single-cylinder engines. For tools working at intervals, such as punching, slotting and plate-cutting machines, coining-presses, etc.,  $\Delta E$  is nearly equal to the whole work performed at each operation.

A fly-wheel reduces the coefficient  $\frac{\Delta E}{2 E_0}$  to a certain fixed amount, being about  $\frac{1}{32}$  for ordinary machinery, and  $\frac{1}{50}$  or  $\frac{1}{60}$  for machinery for fine purposes.

If  $m$  be the reciprocal of the intended value of the coefficient of fluctuation of speed,  $\Delta E$  the fluctuation of energy,  $I$  the moment of inertia of the fly-wheel alone, and  $a_0$  its mean angular velocity,  $I = \frac{mg\Delta E}{a_0^2}$ . As the rim of a fly-wheel is usually heavy in comparison with the arms,  $I$  may be taken to equal  $Wr^2$ , in which  $W$  = weight of rim in pounds, and  $r$  the radius of the wheel; then  $W = \frac{mg\Delta E}{a_0^2 r^2} = \frac{mg\Delta E}{v^2}$ , if  $v$  be the velocity of the rim in feet per second. The usual mean radius of the fly-wheel in steam-engines is from three to five times the length of the crank. The ordinary values of the product  $mg$ , the unit of time being the second, lie between 1000 and 2000 feet. (Abridged from Rankine, S. E., p. 62.)

Thurston gives for engines with automatic valve-gear  $W = 250,000 \frac{ASp}{R^2 D^2}$ , in which  $A$  = area of piston in square inches,  $S$  = stroke in feet,

$p$  = mean steam-pressure in lbs. per sq. in.,  $R$  = revolutions per minute,  $D$  = outside diameter of wheel in feet. Thurston also gives for ordinary forms of non-condensing engine with a ratio of expansion between 3 and

5,  $W = \frac{aAS}{R^2 D^2}$ , in which  $a$  ranges from 10,000,000 to 15,000,000, averaging 12,000,000. For gas-engines, in which the charge is fired with every revolution, the *American Machinist* gives this latter formula, with  $a$  doubled, or 24,000,000. Presumably, if the charge is fired every other revolution,  $a$  should be again doubled.

Rankine ("Useful Rules and Tables," p. 247) gives  $W = 475,000 \frac{ASp}{VD^2 R^2}$ , in which  $V$  is the variation of speed, per cent of the mean speed.

Thurston's first rule above given corresponds with this if we take  $V = 1.9$ .

Hartnell (*Proc. Inst. M. E.*, 1882, 427) says: The value of  $V$ , or the variation permissible in portable engines, should not exceed 3% with an ordinary load, and 4% when heavily loaded. In fixed engines, for ordinary purposes,  $V = 2\frac{1}{2}$  to 3%. For good governing or special purposes, such as cotton-spinning, the variation should not exceed  $1\frac{1}{2}$  to 2%.

F. M. Rites (*Trans. A. S. M. E.*, xiv, 100) develops a new formula for weight of rim, viz.,  $W = \frac{C \times \text{I.H.P.}}{R^3 D^2}$ , and weight of rim per horse-power

$= \frac{C}{R^3 D^2}$ , in which  $C$  varies from 10,000,000,000 to 20,000,000,000; also using the latter value of  $C$ , he obtains for the energy of the fly-wheel  $Mv^2 = \frac{W}{2} \frac{(3.14)^2 D^2 R^2}{3600} = \frac{C \times \text{H.P.} (3.14)^2 D^2 R^2}{R^3 D^2 \times 64.4 \times 3600} = \frac{850,000 \text{ H.P.}}{R}$ . Fly-wheel energy per H.P. =  $850,000 \div R$ .

The limit of variation of speed with such a weight of wheel from excess of power per fraction of revolution is less than 0.0023.

The value of the constant  $C$  given by Mr. Rites was derived from practice of the Westinghouse single-acting engines used for electric-lighting. For double-acting engines in ordinary service a value of  $C = 5,000,000,000$  would probably be ample.

From these formulæ it appears that the weight of the fly-wheel for a given horse-power should vary inversely with the cube of the revolutions and the square of the diameter.

J. B. Stanwood (*Eng'g*, June 12, 1891) says: Whenever 480 feet is the lowest piston-speed probable for an engine of a certain size, the fly-wheel weight for that speed approximates closely to the formula

$$W = 700,000 d^2 s \div D^2 R^2.$$

$W$  = weight in pounds,  $d$  = diameter of cylinder in inches,  $s$  = stroke in inches,  $D$  = diameter of wheel in feet,  $R$  = revolutions per minute, corresponding to 480 feet piston-speed.

In a Ready Reference Book published by Mr. Stanwood, Cincinnati, 1892, he gives the same formula, with coefficients as follows: For slide-valve engines, ordinary duty, 350,000; same, electric lighting, 700,000; for automatic high-speed engines, 1,000,000; for Corliss engines, ordinary duty 700,000, electric lighting 1,000,000.



Thurston's formula above given,  $W = aAS \div R^2D^2$  with  $a = 12,000,000$  if reduced to terms of  $d$  and  $s$  in ins., becomes  $W = 785,400 d^2s \div R^2D^2$ .

If we reduce it to terms of horse-power, we have I.H.P. =  $2ASPR \div 33,000$ , in which  $P$  = mean effective pressure. Taking this at 40 lbs., we obtain  $W = 5,000,000,000$  I.H.P.  $\div R^3D^2$ . If mean effective pressure = 30 lbs., then  $W = 6,666,000,000$  I.H.P.  $\div R^3D^2$ .

Emil Theiss (*Am. Mach.*, Sept. 7 and 14, 1893) gives the following values of  $d$ , the coefficient of steadiness, which is the reciprocal of what Rankine calls the coefficient of fluctuation:

For engines operating—

Hammering and crushing machinery.....	$d = 5$
Pumping and shearing machinery.....	$d = 20$ to 30
Weaving and paper-making machinery.....	$d = 40$
Milling machinery.....	$d = 50$
Spinning machinery.....	$d = 50$ to 100
Ordinary driving-engines (mounted on bed-plate), belt transmission.....	$d = 35$
Gear-wheel transmission.....	$d = 50$

Mr. Theiss's formula for weight of fly-wheel in pounds is  $W = i \times \frac{d \times \text{I.H.P.}}{V^2 \times n}$ , where  $d$  is the coefficient of steadiness,  $V$  the mean velocity of the fly-wheel rim in feet per second,  $n$  the number of revolutions per minute,  $i$  = a coefficient obtained by graphical solution, the values of which for different conditions are given in the following table. In the lines under "cut-off,"  $p$  means "compression to initial pressure," and  $O$  "no compression."

#### VALUES OF $i$ . SINGLE-CYLINDER NON-CONDENSING ENGINES.

Piston-speed, ft. per min.	Cut-off, 1/6.		Cut-off, 1/4.		Cut-off, 1/3.		Cut-off, 1/2.	
	Comp. $p$	$O$	Comp. $p$	$O$	Comp. $p$	$O$	Comp. $p$	$O$
200	272,690	218,580	242,010	209,170	220,760	201,920	193,340	182,840
400	240,810	187,430	208,200	179,460	188,510	170,040	174,630	167,860
600	194,670	145,400	168,590	136,460	165,210	146,610	.....	.....
800	158,200	108,690	162,070	135,260	.....	.....	.....	.....

#### SINGLE-CYLINDER CONDENSING ENGINES.

Piston-speed, ft. per min.	Cut-off, 1/8.		Cut-off, 1/6.		Cut-off, 1/4.		Cut-off, 1/3.		Cut-off, 1/2.	
	Comp. $p$	$O$	Comp. $p$	$O$	Comp. $p$	$O$	Comp. $p$	$O$	Comp. $p$	$O$
200	265,560	176,560	234,160	173,660	204,210	167,140	189,600	161,830	172,690	156,990
400	194,550	117,870	174,380	118,350	164,720	133,080	174,630	151,680	.....	.....
600	148,780	140,090	.....	.....	.....	.....	.....	.....	.....	.....

#### TWO-CYLINDER ENGINES, CRANKS AT 90°.

Piston-speed, ft. per min.	Cut-off, 1/6.		Cut-off, 1/4.		Cut-off, 1/3.		Cut-off, 1/2.	
	Comp. $p$	$O$	Comp. $p$	$O$	Comp. $p$	$O$	Comp. $p$	$O$
200	71,980	} Mean 60,140	59,420	} Mean 54,340	49,272	} Mean 50,000	37,920	} Mean 36,950
400	70,160		57,000		49,150		35,000	
600	70,040		57,480		49,220		35,000	
800	70,040		60,140		.....		.....	

#### THREE-CYLINDER ENGINES, CRANKS AT 120°.

Piston-speed, ft. per min.	Cut-off, 1/6.		Cut-off, 1/4.		Cut-off, 1/3.		Cut-off, 1/2.	
	Comp. $p$	$O$	Comp. $p$	$O$	Comp. $p$	$O$	Comp. $p$	$O$
200	33,810	32,240	33,810	35,500	34,540	33,450	35,260	32,370
800	30,190	31,570	35,140	33,810	36,470	32,850	33,810	32,370

As a mean value of  $i$  for these engines we may use 33,810.

**Weight of Fly-wheels for Alternating-current Units.**—(J. Begtrup, *Am. Mach.*, July 10, 1902.)—

$$W D^2 + W_1 D_1^2 = \frac{14,000,000 H U}{N^3 V},$$

In which  $W$  = weight of rim of fly-wheel in pounds,  $D$  = mean diameter of rim in feet,  $W_1$  = weight of armature in pounds,  $D_1$  = mean diameter of armature in feet,  $H$  = rated horse-power of engine,  $U$  = a factor of steadiness,  $N$  = number of revolutions per minute,  $V$  = maximum instantaneous displacement in degrees, not to exceed 5 degrees divided by the number of poles on the generator, according to the rule of the General Electric Company.

For simple horizontal engines, length of connecting-rod = 5 cranks,  $U = 90$ ; (ditto, no account being taken of angularity of connecting-rod,  $U = 64$ ); cross-compound horizontal engines, connecting-rod = 5 cranks,  $U = 51$ ; ditto, vertical engines, heavy reciprocating parts, unbalanced,  $U = 78$ ; vertical compound engines, cranks 180 degrees apart, reciprocating parts balanced,  $U = 60$ .

The small periodical variation in velocity (not angular displacement) can be determined from the following formula:

$$F = \frac{387,700,000 H Z}{N^3 (W D^2 + W_1 D_1^2)},$$

In which  $H$  = rated horse-power,  $Z$  = a factor of steadiness,  $N$  = revs. per min.,  $D$  = mean diameter of fly-wheel rim in feet,  $W$  = weight of fly-wheel rim in pounds,  $D_1$  = mean diameter of armature or field in feet,  $W_1$  = weight of armature,  $F$  = variation in per cent of mean speed.

For simple engines and tandem compounds,  $Z = 16$ ; for horizontal cross-compounds,  $Z = 8.5$ ; for vertical cross-compounds, heavy reciprocating parts,  $Z = 12.5$ ; for vertical compounds, cranks opposite, weights balanced,  $Z = 14$ .  $F$  represents here the entire variation, between extremes — not variation from mean speed. It generally varies from 0.25% of mean speed to 0.75% — evidently a negligible quantity.

A mathematical treatment of this subject will be found in a paper by J. L. Astrom, in *Trans. A. S. M. E.*, 1901.

**Centrifugal Force in Fly-wheels.** — Let  $W$  = weight of rim in pounds;  $R$  = mean radius of rim in feet;  $r$  = revolutions per minute,  $g = 32.16$ ;  $v$  = velocity of rim in feet per second =  $2\pi R r \div 60$ .

$$\text{Centrifugal force of whole rim} = F = \frac{W v^2}{g R} = \frac{4 W \pi^2 R r^2}{3600 g} = 0.000341 W R r^2.$$

The resultant, acting at right angles to a diameter, of half of this force tends to disrupt one half of the wheel from the other half, and is resisted by the section of the rim at each end of the diameter. The resultant of half the radial forces taken at right angles to the diameter is  $1 \div \frac{1}{2}\pi = 2/\pi$  of the sum of these forces; hence the total force  $F$  is to be divided by  $2 \times 2 \times 1.5708 = 6.2832$  to obtain the tensile strain on the cross-section of the rim, or, total strain on the cross-section =  $S = 0.00005427 W R r^2$ . The weight  $W_1$  of a rim of cast iron 1 inch square in section is  $2 \pi R \times 3.125 = 19.635 R$  pounds, whence strain per square inch of sectional area of rim =  $S_1 = 0.0010656 R^2 r^2 = 0.0002664 D^2 r^2 = 0.0000270 V^2$ , in which  $D$  = diameter of wheel in feet, and  $V$  is velocity of rim in feet per minute.  $S_1 = 0.0972 v^2$ , if  $v$  is taken in feet per second.

For wrought iron:

$$S_1 = 0.0011366 R^2 r^2 = 0.0002842 D^2 r^2 = 0.0000288 V^2.$$

For steel:

$$S_1 = 0.0011593 R^2 r^2 = 0.0002901 D^2 r^2 = 0.0000294 V^2.$$

For wood:

$$S_1 = 0.0000888 R^2 r^2 = 0.0000222 D^2 r^2 = 0.00000225 V^2.$$

The specific gravity of the wood being taken at 0.6 = 37.5 lbs. per cu. ft., or  $1/12$  the weight of cast iron.

**EXAMPLE.**—Required the strain per square inch in the rim of a cast-iron wheel 30 ft. diameter, 60 revolutions per minute.

*Answer.*— $15^2 \times 60^2 \times 0.0010656 = 831.1$  lbs.

Required the strain per square inch in a cast-iron wheel-rim running a mile a minute. *Answer.*— $0.000027 \times 5280^2 = 752.7$  lbs.

In cast-iron fly-wheel rims, on account of their thickness, there is difficulty in securing soundness, and a tensile strength of 10,000 lbs. per sq. in. is as much as can be assumed with safety. Using a factor of safety of 10 gives a maximum allowable strain in the rim of 1000 lbs. per sq. in., which corresponds to a rim velocity of 6085 ft. per minute.

For any given material, as cast iron, the strength to resist centrifugal force depends only on the velocity of the rim, and not upon its bulk or weight.

Chas. E. Emery (*Cass. Mag.*, 1892) says: It does not appear that fly-wheels of customary construction should be unsafe at the comparatively low speeds now in common use if proper materials are used in construction. The cause of rupture of fly-wheels that have failed is usually either the "running away" of the engine, such as may be caused by the breaking or slackness of a governor-belt, or incorrect design or defective materials of the fly-wheel.

Chas. T. Porter (*Trans. A. S. M. E.*, xiv, 808) states that no case of the bursting of a fly-wheel with a solid rim in a high-speed engine is known. He attributes the bursting of wheels built in segments to insufficient strength of the flanges and bolts by which the segments are held together. [The author, however, since the above was written, saw a solid rim fly-wheel of a high-speed engine which had burst, the cause being a large shrinkage hole at the junction between one of the arms and the rim. The wheel was about 6 ft. diam. Fortunately no one was injured by the accident.] (See also Thurston, "Manual of the Steam-engine," Part II, page 413.)

**Diameters of Fly-wheels for Various Speeds.** — If 6000 feet per minute be the maximum velocity of rim allowable, then  $6000 = \pi R D$ , in which  $R$  = revolutions per minute, and  $D$  = diameter of wheel in feet, whence  $D = 6000 \div \pi R = 1910 \div R$ .

W. H. Boehm, Supt. of the Fly-wheel Dept. of the Fidelity and Casualty Co. (*Eng. News*, Oct. 2, 1902), says: For a given material there is a definite speed at which disruption will occur, regardless of the amount of material used. This mathematical truth is expressed by the formula:

$$V = 1.6 \sqrt{S/W},$$

in which  $V$  is the velocity of the rim of the wheel in feet per second at which disruption will occur,  $W$  the weight of a cubic inch of the material used, and  $S$  the tensile strength of 1 square inch of the material.

For cast-iron wheels made in one piece, assuming 20,000 lbs. per sq. in. as the strength of small test bars, and 10,000 lbs. per sq. in. in large castings, and applying a factor of safety of 10,  $V = 1.6 \sqrt{1000/0.26} = 100$  ft. per second for the safe speed. For cast steel of 60,000 lbs. per sq. in.,  $V = 1.6 \sqrt{6000 \div 0.28} = 233$  ft. per second. This is for wheels made in one piece. If the wheel is made in halves, or sections, the efficiency of the rim joint must be taken into consideration. For belt wheels with flanged and bolted rim joints located between the arms, the joints average only one-fifth the strength of the rim, and no such joint can be designed having a strength greater than one-fourth the strength of the rim. If the rim is thick enough to allow the joint to be reinforced by steel links shrunk on, as in heavy balance wheels, one-third the strength of the rim may be secured in the joint; but this construction can not be applied to belt wheels having thin rims.

For hard maple, having a tensile strength of 10,500 lbs. per sq. in., and weighing 0.0283 lb. per cu. in., we have, using a factor of safety of 20, and remembering that the strength is reduced one-half because the wheel is built up of segments,  $V = 1.6 \sqrt{262.5 \div 0.0283} = 154$  ft. per second. The stress in a wheel varies as the square of the speed, and the factor of safety on speed is the square root of the factor of safety on strength.

Mr. Boehm gives the following table of safe revolutions per minute of cast-iron wheels of different diameters. The flange joint is taken at 0.25 of the strength of a wheel with no joint, the pad joint, that is a wheel made in six segments, with bolted flanges or pads on the arms, = 0.50, and the link joint = 0.60 of the strength of a solid rim.



SAFE REVOLUTIONS PER MINUTE OF CAST-IRON FLY-WHEELS.

Diam. in Ft.	No joint.	Flange joint.	Pad joint.	Link joint.	Diam. in Ft.	No joint.	Flange joint.	Pad joint.	Link joint.
	R.P.M.	R.P.M.	R.P.M.	R.P.M.		R.P.M.	R.P.M.	R.P.M.	R.P.M.
1	1910	955	1350	1480	16	120	60	84	92
2	955	478	675	740	17	112	56	79	87
3	637	318	450	493	18	106	53	75	82
4	478	239	338	370	19	100	50	71	78
5	382	191	270	296	20	95	48	68	74
6	318	159	225	247	21	91	46	65	70
7	273	136	193	212	22	87	44	62	67
8	239	119	169	185	23	84	42	59	64
9	212	106	150	164	24	80	40	56	62
10	191	96	135	148	25	76	38	54	59
11	174	87	123	135	26	74	37	52	57
12	159	80	113	124	27	71	35	50	55
13	147	73	104	114	28	68	34	48	53
14	136	68	96	106	29	66	33	47	51
15	128	64	90	99	30	64	32	45	49

The table is figured for a margin of safety on speed of approximately 3, which is equivalent to a margin on stress developed, or factor of safety in the usual sense, of 9. (*Am. Mach.*, Nov. 17, 1904.)

**Strains in the Rims of Fly-band Wheels Produced by Centrifugal Force.** (James B. Stanwood, *Trans. A. S. M. E.*, xiv, 251.)—Mr. Stanwood mentions one case of a fly-band wheel where the periphery velocity on a 17 ft. 9 in. wheel is over 7500 ft. per minute.

In band-saw mills the blade of the saw is operated successfully over wheels 8 and 9 ft. in diameter, at a periphery velocity of 9000 to 10,000 ft. per minute. These wheels are of cast iron throughout, of heavy thickness, with a large number of arms.

In shingle-machines and chipping-machines where cast-iron disks from 2 to 5 ft. in diameter are employed, with knives inserted radially, the speed is frequently 10,000 to 11,000 ft. per minute at the periphery.

If the rim of a fly-wheel alone be considered, the tensile strain in pounds per square inch of the rim section is  $T = V^2/10$  nearly, in which  $V =$  velocity in feet per second; but this strain is modified by the resistance of the arms, which prevent the uniform circumferential expansion of the rim, and induce a bending as well as a tensile strain. Mr. Stanwood discusses the strains in band-wheels due to transverse bending of a section of the rim between a pair of arms.

When the arms are few in number, and of large cross-section, the rim will be strained transversely to a greater degree than with a greater number of lighter arms. To illustrate the necessary rim thicknesses for various rim velocities, pulley diameters, number of arms, etc., the following table is given, based upon the formula

$$t = 0.475 d \div N^2 \left( \frac{F}{V^2} - \frac{1}{10} \right),$$

in which  $t =$  thickness of rim in inches,  $d =$  diameter of pulley in inches,  $N =$  number of arms,  $V =$  velocity of rim in feet per second, and  $F =$  the greatest strain in pounds per square inch to which any fiber is subjected. The value of  $F$  is taken at 6000 lbs. per sq. in.

## THICKNESS OF RIMS IN SOLID WHEELS.

Diameter of Pulley in inches.	Velocity of Rim in feet per second.	Velocity of Rim in feet per minute.	No. of Arms.	Thickness in inches.
24	50	3,000	6	$\frac{2}{10}$
24	88	5,280	6	$\frac{15}{32}$
48	88	5,280	6	$\frac{15}{16}$
108	184	11,040	16	$\frac{21}{2}$
108	184	11,040	36	$\frac{1}{3}$

If the limit of rim velocity for all wheels be assumed to be 88 ft. per second, equal to 1 mile per minute,  $F = 6000$  lbs., the formula becomes

$$t = 0.475 d \div 0.67 N^2 = 0.7 d \div N^2.$$

When wheels are made in halves or in sections, the bending strain may be such as to make  $t$  greater than that given above. Thus, when the joint comes half way between the arms, the bending action is similar to a beam supported simply at the ends, uniformly loaded, and  $t$  is 50% greater. Then the formula becomes  $t = 0.712 d \div N^2 \left( \frac{F}{V^2} - \frac{1}{10} \right)$ , or for a fixed maximum rim velocity of 88 ft. per second and  $F = 6000$  lbs.,  $t = 1.05 d \div N^2$ . In segmental wheels it is preferable to have the joints opposite the arms. Wheels in halves, if very thin rims are to be employed, should have double arms along the line of separation.

Attention should be given to the proportions of large receiving and tightening pulleys. The thickness of rim for a 48-in. wheel (shown in table) with a rim velocity of 88 ft. per second, is  $\frac{15}{16}$  in. Many wrecks have been caused by the failure of receiving or tightening pulleys whose rims have been too thin. Fly-wheels calculated for a given coefficient of steadiness are frequently lighter than the minimum safe weight. This is true especially of large wheels. A rough guide to the minimum weight of wheels can be deduced from our formulæ. The arms, hub, lugs, etc., usually form from one-quarter to one-third the entire weight of the wheel. If  $b$  represents the face of a wheel in inches, the weight of the rim (considered as a simple annular ring) will be  $w = 0.82 dtb$  lbs. If the limit of speed is 88 ft. per second, then for solid wheels  $t = 0.7 d \div N^2$ . For sectional wheels (joint between arms)  $t = 1.05 d \div N^2$ . Weight of rim for solid wheels,  $w = 0.57 d^2b \div N^2$ , in pounds. Weight of rim in sectional wheels with joints between arms,  $w = 0.86 d^2b \div N^2$ , in pounds. Total weight of wheel: for solid wheel,  $W = 0.76 d^2b \div N^2$  to  $0.86 d^2b \div N^2$ , in pounds. For segmental wheels with joint between arms,  $W = 1.05 d^2b \div N^2$  to  $1.3 d^2b \div N^2$ , in pounds.

(This subject is further discussed by Mr. Stanwood, in vol. xv, and by Prof. Gaetano Lanza, in vol. xvi, *Trans. A. S. M. E.*)

**Arms of Fly-wheels and Pulleys.** — Professor Torrey (*Am. Mach.*, July 30, 1891) gives the following formula for arms of elliptical cross-section of cast-iron wheels:

$W$  = load in pounds acting on one arm;  $S$  = strain on belt in pounds per inch of width, taken at 56 for single and 112 for double belts;  $v$  = width of belt in inches;  $n$  = number of arms;  $L$  = length of arm in feet;  $b$  = breadth of arm at hub;  $d$  = depth of arm at hub, both in inches:  $W = Sv \div n$ ;  $b = WL \div 30 d^2$ . The breadth of the arm is its least dimension = minor axis of the ellipse, and the depth the major axis. This formula is based on a factor of safety of 10.

In using the formula, first assume some depth for the arm, and calculate the required breadth to go with it. If it gives too round an arm, assume the depth a little greater, and repeat the calculation. A second trial will almost always give a good section.

The size of the arms at the hub having been calculated, they may be somewhat reduced at the rim end. The actual amount cannot be calculated, as there are too many unknown quantities. However, the depth

and breadth can be reduced about one-third at the rim without danger, and this will give a well-shaped arm.

Pulleys are often cast in halves, and bolted together. When this is done the greatest care should be taken to provide sufficient metal in the bolts. This is apt to be the very weakest point in such pulleys. The combined area of the bolts at each joint should be about 28/100 the cross-section of the pulley at that point. (Torrey.)

Unwin gives  $d = 0.6337 \sqrt[3]{BD/n}$  for single belts;  
 $d = 0.798 \sqrt[3]{BD/n}$  for double belts;

$D$  being the diameter of the pulley, and  $B$  the breadth of the rim, both in inches. These formulæ are based on an elliptical section of arm in which  $b = 0.4 d$  or  $d = 2.5 b$  on a width of belt =  $4/5$  the width of the pulley rim, a maximum driving force transmitted by the belt of 56 lbs. per inch of width for a single belt and 112 lbs. for a double belt, and a safe working stress of cast iron of 2250 lbs. per square inch.

If in Torrey's formula we make  $b = 0.4 d$ , it reduces to

$$b = \sqrt{\frac{3WL}{187.5}}; d = \sqrt{\frac{3WL}{12}}$$

EXAMPLE. — Given a pulley 10 feet diameter; 8 arms, each 4 feet long; face, 36 inches wide; belt, 30 inches; required the breadth and depth of the arm at the hub. According to Unwin,

$d = 0.6337 \sqrt[3]{BD/n} = 0.633 \sqrt[3]{36 \times 120/8} = 5.16$  for single belt,  $b = 2.06$ ;  
 $d = 0.798 \sqrt[3]{BD/n} = 0.798 \sqrt[3]{36 \times 120/8} = 6.50$  for double belt,  $b = 2.60$ .

According to Torrey, if we take the formula  $b = WL \div 30 d^2$  and assume  $d = 5$  and  $6.5$  inches, respectively, for single and double belts, we obtain  $b = 1.08$  and  $1.33$ , respectively, or practically only one-half of the breadth according to Unwin, and, since transverse strength is proportional to breadth, an arm only one-half as strong.

Torrey's formula is said to be based on a factor of safety of 10, but this factor can be only apparent and not real, since the assumption that the strain on each arm is equal to the strain on the belt divided by the number of arms, is, to say the least, inaccurate. It would be more nearly correct to say that the strain of the belt is divided among half the number of arms. Unwin makes the same assumption in developing his formula, but says it is only in a rough sense true, and that a large factor of safety must be allowed. He therefore takes the low figure of 2250 lbs. per square inch for the safe working strength of cast iron. Unwin says that his equations agree well with practice.

**A Wooden-rim Fly-wheel**, built in 1891 for a pair of Corliss engines at the Amoskeag Mfg. Co.'s mill, Manchester, N.H., is described by C. H. Manning in *Trans. A. S. M. E.*, xiii, 618. It is 30 ft. diam. and 108 in. face. The rim is 12 inches thick, and is built up of 44 courses of ash plank, 2, 3, and 4 inches thick, reduced about  $1/2$  inch in dressing, set edgewise, so as to break joints, and glued and bolted together. There are two hubs and two sets of arms, 12 in each, all of cast iron. The weights are as follows:

Weight (calculated) of ash rim.....	31,855 lbs.
Weight of 24 arms (foundry 45,020).....	40,349 "
Weight of 2 hubs (foundry 35,030).....	31,394± "
Counter-weights in 6 arms.....	664 "
Total, excluding bolts and screws.....	104,262± "

The wheel was tested at 76 revs. per min., being a surface speed of nearly 7200 feet per minute.

**Wooden Fly-wheel of the Willimantic Linen Co.** (Illustrated in *Power*, March, 1893.) — Rim 28 ft. diam., 110 in. face. The rim is carried upon three sets of arms, one under the center of each belt, with 12 arms in each set.

The material of the rim is ordinary whitewood,  $7/8$  in. in thickness, cut into segments not exceeding 4 feet in length, and either 5 or 8 inches in



width. These were assembled by building a complete circle 13 inches in width, first with the 8-inch inside and the 5-inch outside, and then beside it another circle with the widths reversed, so as to break joints. Each piece as it was added was brushed over with glue and nailed with three-inch wire nails to the pieces already in position. The nails pass through three and into the fourth thickness. At the end of each arm four 14-inch bolts secure the rim, the ends being covered by wooden plugs glued and driven into the face of the wheel.

**Wire-wound Fly-wheels for Extreme Speeds.** (*Eng'g News*, August 2, 1890.) — The power required to produce the Mannesmann tubes is very large, varying from 2000 to 10,000 H.P., according to the dimensions of the tube. Since this power is needed for only a short time (it takes only 30 to 45 seconds to convert a bar 10 to 12 ft. long and 4 in. in diameter into a tube), and then some time elapses before the next bar is ready, an engine of 1200 H.P. provided with a large fly-wheel for storing the energy will supply power enough for one set of rolls. These fly-wheels are so large and run at such great speeds that the ordinary method of constructing them cannot be followed. A wheel at the Mannesmann Works, made in Komotau, Hungary, in the usual manner, broke at a tangential velocity of 125 ft. per second. The fly-wheels designed to hold at more than double this speed consist of a cast-iron hub to which two steel disks, 20 ft. in diameter, are bolted; around the circumference of the wheel thus formed 70 tons of No. 5 wire are wound under a tension of 50 lbs. In the Mannesmann Works at Landore, Wales, such a wheel makes 240 revolutions a minute, corresponding to a tangential velocity of 15,080 ft. or 2.85 miles per minute.

### THE SLIDE-VALVE.

**Definitions.** — *Travel* = total distance moved by the valve.

*Throw of the Eccentric* = eccentricity of the eccentric = distance from the center of the shaft to the center of the eccentric disk =  $\frac{1}{2}$  the travel of the valve.

*Lap of the valve*, also called 'outside lap or steam-lap' = distance the outer or steam edge of the valve extends beyond or laps over the steam edge of the port when the valve is in its central position.

*Inside lap*, or *exhaust-lap* = distance the inner or exhaust edge of the valve extends beyond or laps over the exhaust edge of the port when the valve is in its central position. The inside lap is sometimes made zero, or even negative, in which latter case the distance between the edge of the valve and the edge of the port is sometimes called exhaust clearance, or inside clearance.

*Lead of the valve* = the distance the steam-port is opened when the engine is on its center and the piston is at the beginning of the stroke.

*Lead-angle* = the angle between the position of the crank when the valve begins to be opened and its position when the piston is at the beginning of the stroke.

The valve is said to have lead when the steam-port opens before the piston begins its stroke. If the piston begins its stroke before the admission of steam begins, the valve is said to have negative lead, and its amount is the lap of the edge of the valve over the edge of the port at the instant when the piston stroke begins.

*Lap-angle* = the angle through which the eccentric must be rotated to cause the steam edge to travel from its central position the distance of the lap.

*Angular advance of the eccentric* = lap-angle + lead-angle.

*Linear advance* = lap + lead.

**Effect of Lap, Lead, etc., upon the Steam Distribution.** — Given valve-travel  $2\frac{3}{4}$  in., lap  $\frac{3}{4}$  in., lead  $\frac{1}{16}$  in., exhaust-lap  $\frac{1}{8}$  in., required crank position for admission, cut-off, release and compression, and greatest port-opening. (Halsey on Slide-valve Gears.) Draw a circle of diameter  $fh$  = travel of valve. From  $O$  the center set off  $Oa$  = lap and  $ab$  = lead, erect perpendiculars  $Oe$ ,  $ac$ ,  $bd$ ; then  $ec$  is the lap-angle and  $cd$  the lead-angle, measured as arcs. Set off  $fg = cd$ , the lead-angle; then  $Og$  is the position of the crank for steam admission. Set off  $2ec + cd$  from  $h$  to  $i$ ; then  $Oi$  is the crank-angle for cut-off, and  $fk + fh$  is the fraction of stroke completed at cut-off. Set off  $Ol$  = exhaust-



while the exhaust edge of the valve uncovers its lap. Release then takes place when the crank lacks one lap-angle and one lead-angle minus one exhaust-lap angle of having reached the center, and compression when the crank lacks lap-angle + lead-angle + exhaust-lap angle of having reached the center.

The above discussion of the relative position of the crank, piston, and valve for the different points of the stroke is accurate only with a connecting-rod of infinite length.

For actual connecting-rods the angular position of the rod causes a distortion of the position of the valve, causing the events to take place too late in the forward stroke and too early in the return. The correction of this distortion may be accomplished to some extent by setting the valve so as to give equal lead on both forward and return stroke, and by altering the exhaust-lap on one end so as to equalize the release and compression. F. A. Halsey, in his *Slide-valve Gears*, describes a method of equalizing the cut-off without at the same time affecting the equality of the lead. In designing slide-valves the effect of angularity of the connecting-rod should be studied on the drawing-board, and preferably by the use of a model.

**Sweet's Valve-diagram.** — To find outside and inside lap of valve for different cut-offs and compressions (see Fig. 171): Draw a circle whose diameter equals travel of valve. Draw diameter  $BA$  and continue to  $A^1$ , so that the length  $AA^1$  bears the same ratio to  $XA$  as the

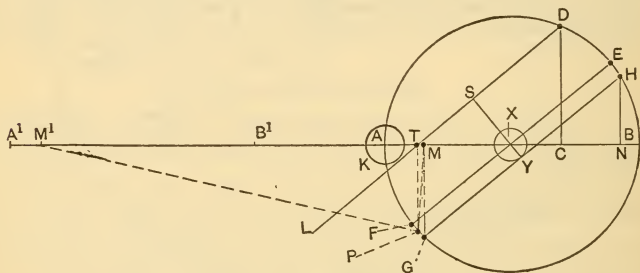

FIG. 171. — Sweet's Valve Diagram.

length of connecting-rod does to length of engine-crank. Draw small circle  $K$  with a radius equal to lead. Lay off  $AC$  so that ratio of  $AC$  to  $AB$  = cut-off in parts of the stroke. Erect perpendicular  $CD$ . Draw  $DL$  tangent to  $K$ ; draw  $XS$  perpendicular to  $DL$ ;  $XS$  is then outside lap of valve.

To find release and compression: If there is no inside lap, draw  $FE$  through  $X$  parallel to  $DL$ .  $F$  and  $E$  will be position of crank for release and compression. If there is an inside lap, draw a circle about  $X$ , in which radius  $XY$  equals inside lap. Draw  $HG$  tangent to this circle and parallel to  $DL$ ; then  $H$  and  $G$  are crank positions for release and for compression. Draw  $HN$  and  $MG$ , then  $AN$  is piston position at release and  $A'M$  piston position at compression,  $AB$  being considered stroke of engine.

To make compression alike on each stroke it is necessary to increase the inside lap on crank end of valve, and to decrease by the same amount the inside lap on back end of valve. To determine this amount, through  $M$  with a radius  $MM^1 = AA^1$ , draw arc  $MP$ , from  $P$  draw  $PT$  perpendicular to  $AB$ , then  $TM$  is the amount to be added to inside lap on crank end, and to be deducted from inside lap on back end of valve, inside lap being  $XY$ .

For the *Bilgram Valve-Diagram*, see Halsey on *Slide-valve Gears*.

**The Zeuner Valve-diagram** is given in most of the works on the steam-engine, and in treatises on valve-gears, as Zeuner's, Peabody's, and Spangler's. The following paragraphs show how the Zeuner valve-diagram may be employed as a convenient means (1) for finding the lap, lead, etc., of a slide-valve when the points of admission, cut-off, and release



are given; and (2) for obtaining the points of admission, cut-off, release, and compression, etc., when the travel, the laps, and the lead of the valve are given. In working out these two problems, the connecting-rod is supposed to be of infinite length.

*Determination of the Lap, Lead, etc., of a Slide-valve for Given Steam Distribution.* — Given the points of admission, cut-off, and release, to find the point of compression, the lap, the lead, the exhaust lap, the angular advance, and the port-openings at different fractions of the stroke.

Draw a straight line  $AA'$ , Fig. 172, to represent on any scale the travel of the valve, and on it draw a circle, with the center  $O$ , to represent the path of the center of the eccentric. The line and the circle will also represent on a different scale the length of stroke of the piston and the path of the crank-pin. On the circle, which is called the *crank circle*, mark  $B$ ,

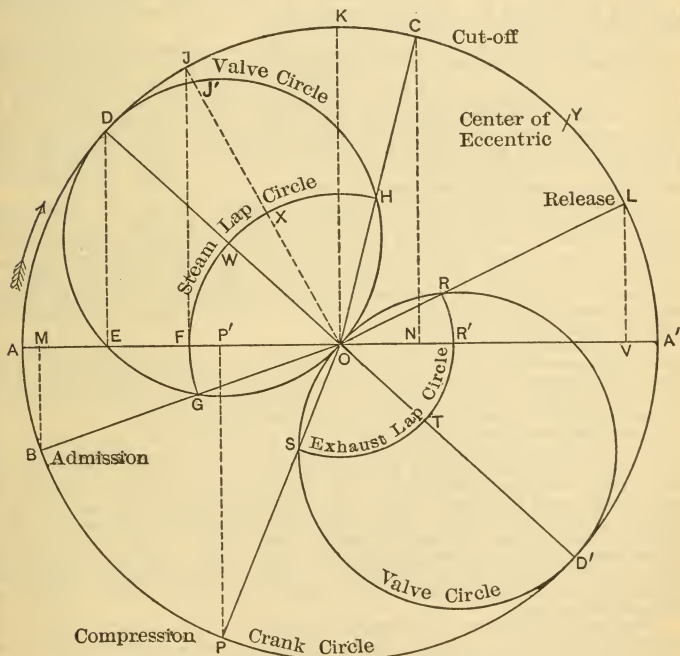

FIG. 172.—Zeuner's Valve Diagram.

the position of the crank-pin when *admission* of steam begins, the direction of motion of the crank being shown by the arrow;  $C$ , the position of the crank-pin at *cut-off*; and  $L$ , its position at *release*. From these points draw perpendiculars  $BM$ ,  $CN$ , and  $LV$ , to the line  $AA'$ ;  $M$ ,  $N$ , and  $V$  will then represent the positions of the piston at admission, cut-off, and release respectively, the admission taking place, as shown, before the piston reaches the end of the stroke in the direction  $OA$ , and release taking place before the end of the stroke in the direction  $OA'$ .

Bisect the arc  $BC$  at  $D$ , and draw the diameter  $DOD'$ . On  $DO$  draw the circle  $DHOGE$ , called the *valve circle*. Draw  $OB$ , cutting the valve circle at  $G$ ; and  $OC$ , cutting it at  $H$ . Then  $OG = OH$  is the *lap* of the valve, measured on the scale in which  $OA$  is the half-travel of the valve. With  $OG$  as radius draw the arc  $GFH$ , called the *steam-lap circle*, or, for short, the *lap circle*.

Mark the point  $E$ , at which the valve circle cuts the line  $OA$ . The distance  $FE$  represents the *lead* of the valve, and  $BG = AF$  is the *maximum port-opening*. A perpendicular drawn from  $OA$  at  $E$  will cut the valve circle and the crank circle at  $D$ , since the triangle  $DEO$  is a right-angled triangle drawn in the semicircle  $DEGO$ .

Erect the perpendicular  $FJ$ , then angle  $DOJ = AOB$  is the *lead-angle* and  $JOK$  is the *lap-angle*,  $OK$  being a perpendicular to  $AA'$  drawn from  $O$ .  $DOK$  is the sum of the lap and lead angles, that is, the *angular advance*, by which the eccentric must be set beyond  $90^\circ$  ahead of the crank. Set off  $KY = KD$ ; then  $Y$  is the position of the *center of the eccentric* when the crank is in the position  $OA$ .

To find the point of compression, set off  $D'P = D'L$ ; then  $P$  is the *point of compression*.

Draw  $OP$  and  $OL$ . On  $OD'$  draw the valve circle  $ORD'S$ , cutting  $OL$  at  $R$  and  $OP$  at  $S$ . With  $OR$  as a radius draw the arc of the *exhaust-lap circle*,  $RTS$ ;  $OR = OS$  is the *exhaust lap*.

The *port-opening* at any part of the stroke, or corresponding position of the crank, is represented by the radial distances, as  $EF$ ,  $DW$ , and  $J'X$ , intercepted between the lap and the valve circles on radii drawn from  $O$ . Thus, on the radius  $OB$ , the port-opening is zero when steam admission is about to begin; on the radius  $OA$ , when the crank is on the dead center the opening is  $EF$ , or equal to the lead of the valve; on the radius  $DO$ , midway between the point of admission and the point of cut-off, the opening is a maximum  $DW = AF = BG$ ; on the radius  $OC$  it is zero again when steam has just been cut off.

In like manner the *exhaust opening* is represented by the radial distances intercepted between the exhaust-lap circle,  $RR'TS$ , and the valve circle,  $ORD'S$ . On the radius  $OL$  it is zero when release begins; on  $OD'$  it is  $TD'$ , a maximum; and on  $OP$  it is zero again when compression begins.

*Determination of the Steam Distribution, etc., for a Given Valve.* — Given the valve travel, the lap, the lead, and the exhaust lap, to find the maximum port-opening, the angular advance, and the points of admission, cut-off, release, and compression.

This problem is the reverse of the preceding. Draw  $AOA'$  to represent the valve travel on a certain scale,  $O$  being the middle point, and on this line on the same scale set off  $OF =$  the lap,  $FE =$  the lead, and  $OR' =$  the exhaust lap.  $AF$  then will be the *maximum port-opening*. Draw the perpendiculars  $OK$  and  $ED$ .  $DOK$  is the *angular advance*.

Draw the diameter  $DOD'$ , and on  $DO$  and  $D'O$  draw the two valve circles. From  $O$ , the center, with a radius  $OF$ , the lap, draw the arc of the steam-lap circle cutting the valve circle in  $G$  and  $H$ . Through  $G$  draw  $OB$ , and through  $H$  draw  $OC$ ;  $B$  then is the *point of admission*, and  $C$  the *point of cut-off*. With  $OR$ , the exhaust lap, as a radius, draw the arc of the exhaust-lap circle,  $RTS$ , cutting the valve circle in  $R$  and  $S$ . Through  $R$  draw  $OL$ , and through  $S$  draw  $OP$ . Then  $L$  is the *point of release* and  $P$  the *point of compression*. Draw the perpendiculars  $BM$ ,  $CN$ ,  $LV$ , and  $PP'$ , to find  $M$ ,  $N$ ,  $V$ , and  $P'$ , the respective positions on the stroke of the piston when *admission*, *cut-off*, *release*, and *compression* take place.

*Practical Application of Zeuner's Diagram.* — In problems solved by means of the Zeuner diagram, the results obtained on the drawings are *relative dimensions* or the *ratios* of the several dimensions to a given dimension the scale of which is known, such as the valve travel, the maximum port-opening, or the length of stroke. In problems similar to the first problem given above, the known dimensions are usually the length of stroke, the maximum port-opening,  $AF$ , which is calculated from data of the dimensions of cylinder, the piston speed, and the allowable velocity of steam through the port. The length of the stroke being represented on a certain scale by  $AA'$ , the points of admission, cut-off, release, and compression, in fractions of the stroke, are measured respectively by  $A'M$ ,  $AN$ ,  $AV$ , and  $A'P$  on the same scale. The actual dimension of the maximum port-opening is represented on a different scale by  $AF$ , therefore the actual dimensions of the lap, lead, and exhaust lap are measured respectively by  $OF$ ,  $FE$ , and  $OR'$  on the same scale as  $AF$ ; or, in other words, the lap, lead, and exhaust lap are respectively the

ratios  $\frac{OF}{AF}$ ,  $\frac{FE}{AF}$ , and  $\frac{OR'}{AF}$ , each multiplied by the maximum port-opening.

In problems similar to the second problem, the actual dimensions of the lap, the lead, the exhaust lap, and the valve travel are all known, and are laid down on the same scale on the line  $AA'$ , representing the valve travel; and the maximum port-opening is found by the solution of the problem to be  $AF$ , measured on the same scale; or the maximum port-opening =  $\frac{1}{2}$  valve travel minus the lap. Also in this problem  $AA'$  represents the known length of stroke on a certain scale, and the points of admission, cut-off, release, and compression, in fractions of the stroke, are represented by the ratios which  $A'M$ ,  $AN$ ,  $AV$ , and  $A'P$ , respectively, bear to  $AA'$ .

**Port-opening.** — The area of port-opening is usually made such that the velocity of the steam in passing through it should not exceed 6000 ft. per min. The ratio of port area to piston area will vary with the piston-speed as follows:

For speed of piston, } ft. per min.	100	200	300	400	500	600	700	800	900	1000	1200
Port area = piston } area $\times$	0.017	.033	.05	.067	.083	.1	.107	.133	.15	.167	.2

For a velocity of 6000 ft. per min.,

$$\text{Port area} = \text{sq. of diam. of cyl.} \times \text{piston speed} \div 7639.$$

The length of the port-opening may be equal to or something less than the diameter of the cylinder, and the width = area of port-opening  $\div$  its length.

The bridge between steam and exhaust ports should be wide enough to prevent a leak of steam into the exhaust due to overtravel of the valve.

The width of exhaust port = width of steam port +  $\frac{1}{2}$  travel of valve + inside lap - width of bridge.

**Lead.** (From Peabody's Valve-gears.) — The lead, or the amount that the valve is open when the engine is on a dead point, varies, with the type and size of the engine, from a very small amount, or even nothing, up to  $\frac{3}{8}$  of an inch or more. Stationary-engines running at slow speed may have from  $\frac{1}{64}$  to  $\frac{1}{16}$  inch lead. The effect of compression is to fill the waste space at the end of the cylinder with steam; consequently, engines having much compression need less lead. Locomotive-engines having the valves controlled by the ordinary form of Stephenson link-motion may have a small lead when running slowly and with a long cut-off, but when at speed with a short cut-off the lead is at least  $\frac{1}{4}$  inch; and locomotives that have valve-gear which gives constant lead commonly have  $\frac{1}{4}$  inch lead. The lead-angle is the angle the crank makes with the line of dead points at admission. It may vary from  $0^\circ$  to  $8^\circ$ .

**Inside Lead.** — Weisbach (vol. ii, p. 296) says: Experiment shows that the earlier opening of the exhaust ports is especially of advantage, and in the best engines the lead of the valve upon the side of the exhaust, or the inside lead, is  $\frac{1}{25}$  to  $\frac{1}{15}$ ; i.e., the slide-valve at the lowest or highest position of the piston has made an opening whose height is  $\frac{1}{25}$  to  $\frac{1}{15}$  of the whole throw of the slide-valve. The outside lead of the slide-valve or the lead on the steam side, on the other hand, is much smaller, and is often only  $\frac{1}{100}$  of the whole throw of the valve.

**Effect of Changing Outside Lap, Inside Lap, Travel and Angular Advance. (Thurston.)**

	Admission.	Expansion.	Exhaust.	Compression.
Incr. O.L.	is later, ceases sooner	occurs earlier, continues longer	is unchanged	begins at same point
Incr. I.L.	unchanged	begins as before, continues longer	occurs later, ceases earlier	begins sooner, continues longer
Incr. T.	begins sooner, continues longer	begins later, ceases sooner	begins later, ceases later	begins later, ends sooner
Incr. A.A.	begins earlier, period unaltered	begins sooner, per. the same	begins earlier, per. unchanged	begins earlier, per. the same



Zeuner gives the following relations (Weisbach-Dubois, vol. ii, p. 307):

If  $S$  = travel of valve,  $p$  = maximum port opening;

$L$  = steam-lap,  $l$  = exhaust-lap;

$R$  = ratio of steam-lap to half travel =  $\frac{L}{0.5 S}$ ,  $L = \frac{R}{2} \times S$ ;

$r$  = ratio of exhaust-lap to half travel =  $\frac{l}{0.5 S}$ ,  $l = \frac{r}{2} \times S$ ;

$S = 2p + 2L = 2p + R \times S$ ;  $S = \frac{2p}{1-R}$ .

If  $\alpha$  = angle  $BOC$  between positions of crank at admission and at cut-off, and  $\beta$  = angle  $LOP$  between positions of crank at release and at compression, then  $R = 1/2 \frac{\sin(180^\circ - \alpha)}{\sin 1/2 \alpha}$ ;  $r = 1/2 \frac{\sin(180^\circ - \beta)}{\sin 1/2 \beta}$ .

### Crank-angles for Connecting-rods of Different Lengths.

#### FORWARD AND RETURN STROKES.

Fraction of Stroke from Commencement.	Ratio of Length of Connecting-rod to Length of Stroke.												Infinite For. or Ret.
	2		2 1/2		3		3 1/2		4		5		
	For.	Ret.	For.	Ret.	For.	Ret.	For.	Ret.	For.	Ret.	For.	Ret.	
.01	10.3	13.2	10.5	12.8	10.6	12.6	10.7	12.4	10.8	12.3	10.9	12.1	11.5
.02	14.6	18.7	14.9	18.1	15.1	17.8	15.2	17.5	15.3	17.4	15.5	17.1	16.3
.03	17.9	22.9	18.2	22.2	18.5	21.8	18.7	21.5	18.8	21.3	19.0	21.0	19.9
.04	20.7	26.5	21.1	25.7	21.4	25.2	21.6	24.9	21.8	24.6	22.0	24.3	23.1
.05	23.2	29.6	23.6	28.7	24.0	28.2	24.2	27.8	24.4	27.5	24.7	27.2	25.8
.10	33.1	41.9	33.8	40.8	34.3	40.1	34.6	39.6	34.9	39.2	35.2	38.7	36.9
.15	41	51.5	41.9	50.2	42.4	49.3	42.9	48.7	43.2	48.3	43.6	47.7	45.6
.20	48	59.6	48.9	58.2	49.6	57.3	50.1	56.6	50.4	56.2	50.9	55.5	53.1
.25	54.3	66.9	55.4	65.4	56.1	64.4	56.6	63.7	57.0	63.3	57.6	62.6	60.0
.30	60.3	73.5	61.5	72.0	62.2	71.0	62.8	70.3	63.3	69.8	63.9	69.1	66.4
.35	66.1	79.8	67.3	78.3	68.1	77.3	68.8	76.6	69.2	76.1	69.9	75.3	72.5
.40	71.7	85.8	73.0	84.3	73.9	83.3	74.5	82.6	75.0	82.0	75.7	81.3	78.5
.45	77.2	91.5	78.6	90.1	79.6	89.1	80.2	88.4	80.7	87.9	81.4	87.1	84.3
.50	82.8	97.2	84.3	95.7	85.2	94.8	85.9	94.1	86.4	93.6	87.1	92.9	90.0
.55	88.5	102.8	89.9	101.4	90.9	100.4	91.6	99.8	92.1	99.3	92.9	98.6	95.7
.60	94.2	108.3	95.7	107.0	96.7	106.1	97.4	105.5	98.0	105.0	98.7	104.3	101.5
.65	100.2	113.9	101.7	112.7	102.7	111.9	103.4	111.2	103.9	110.8	104.7	110.1	107.5
.70	106.5	119.7	108.0	118.5	109.0	117.8	109.7	117.2	110.2	116.7	110.9	116.1	113.6
.75	113.1	125.7	114.6	124.6	115.6	123.9	116.3	123.4	116.7	123.0	117.4	122.4	120.0
.80	120.4	132	121.8	131.1	122.7	130.4	123.4	129.9	123.8	129.6	124.5	129.1	126.9
.85	128.5	139	129.8	138.1	130.7	137.6	131.3	137.1	131.7	136.8	132.3	136.4	134.4
.90	138.1	146.9	139.2	146.2	139.9	145.7	140.4	145.4	140.8	145.1	141.3	144.8	143.1
.95	150.4	156.8	151.3	156.4	151.8	156.0	152.2	155.8	152.5	155.6	152.8	155.3	154.2
.96	153.5	159.3	154.3	158.9	154.8	158.6	155.1	158.4	155.4	158.2	155.7	158.0	156.9
.97	157.1	162.1	157.8	161.8	158.2	161.5	158.5	161.3	158.7	161.2	159.0	161.0	160.1
.98	161.3	165.4	161.9	165.1	162.2	164.9	162.5	164.8	162.6	164.7	162.9	164.5	163.7
.99	166.8	169.7	167.2	169.5	167.4	169.4	167.6	169.3	167.7	169.2	167.9	169.1	168.5
1.00	180	180	180	180	180	180	180	180	180	180	180	180	180

Ratio of Lap and of Port-opening to Valve-travel. — The table on page 1059, giving the ratio of lap to travel of valve and ratio of travel to port-opening, is abridged from one given by Buel in Weisbach-Dubois,



**Relative Motions of Crosshead and Crank.** —  $L$  = length of connecting-rod,  $R$  = length of crank,  $\theta$  = angle of crank with center line of engine,  $D$  = displacement of crosshead from the beginning of its stroke,  $V$  = velocity of crank-pin,  $V_1$  = velocity of piston.

For  $R=1$ ,  $D = \text{ver sin } \theta \pm (L - \sqrt{L^2 - \sin^2 \theta})$ ,

$$V_1 = V \sin \theta \left( 1 \pm \frac{\cos \theta}{\sqrt{L^2 - \sin^2 \theta}} \right).$$

From these formulæ Mr. A. F. Nagle computes the following:

**PISTON DISPLACEMENT AND PISTON VELOCITY FOR EACH 10° OF MOTION OF CRANK.** Length of crank = 1. Length of connecting-rod = 5. Piston velocity  $V_1$  for vel. of crank-pin = 1.

Angle of Cr'nk	Displacement.		Velocity.		Angle of Cr'nk	Displacement.		Velocity.	
	For-ward.	Back.	For-ward.	Back.		For-ward.	Back.	For-ward.	Back.
10°	0.018	0.012	0.207	.....	60°	0.576	0.424	0.954	0.778
20°	0.072	0.048	0.406	.....	70°	0.747	0.569	1.005	0.875
30°	0.159	0.109	0.587	.....	80°	0.924	0.728	1.019	0.950
40°	0.276	0.192	0.742	.....	84°	1.000	.....	1.011	.....
50°	0.416	0.298	0.865	.....	90°	1.101	0.899	1.000	1.000

### PERIODS OF ADMISSION, OR CUT-OFF, FOR VARIOUS LAPS AND TRAVELS OF SLIDE-VALVES.

The two following tables are from Clark on the Steam-engine. In the first table are given the periods of admission corresponding to travels of valve of from 12 in. to 2 in., and laps of from 2 in. to  $\frac{3}{8}$  in., with  $\frac{1}{4}$  in. and  $\frac{1}{8}$  in. of lead. With greater leads than those tabulated, the steam would be cut off earlier than as shown in the table.

The influence of a lead of  $\frac{5}{16}$  in. for travels of from  $\frac{15}{8}$  in. to 6 in., and laps of from  $\frac{1}{2}$  in. to  $1\frac{1}{2}$  in., as calculated for in the second table, is exhibited by comparison of the periods of admission in the table, for the same lap and travel. The greater lead shortens the period of admission, and increases the range for expansive working.

### Periods of Admission, or Points of Cut-off, for Given Travels and Laps of Slide-valves.

Travel of Valve.	Lead.	Periods of Admission, or Points of Cut-off, for the following Laps of Valves in inches.									
		2	13/4	11/2	11/4	1	7/8	3/4	5/8	1/2	3/8
in.	in.	%	%	%	%	%	%	%	%	%	%
12	1/4	88	90	93	95	96	97	98	98	99	99
10	1/4	82	87	89	92	95	96	97	98	98	99
8	1/4	72	78	84	88	92	94	95	96	98	98
6	1/4	50	62	71	79	86	89	91	94	96	97
5 1/2	1/8	43	56	68	77	85	88	91	94	96	97
5	1/8	32	47	61	72	82	86	89	92	95	97
4 1/2	1/8	14	35	51	66	78	83	87	90	94	96
4	1/8	.....	17	39	57	72	78	83	88	92	95
3 1/2	1/8	.....	.....	20	44	63	71	79	84	90	94
3	1/8	.....	.....	.....	23	50	61	71	79	86	91
2 1/2	1/8	.....	.....	.....	.....	27	43	57	70	80	88
2	1/8	.....	.....	.....	.....	.....	.....	33	52	70	81



Periods of Admission, or Points of Cut-off, for given Travels and Laps of Slide-valves.

Constant lead,  $\frac{5}{16}$ .

Travel. Inches.	Lap.								
	$\frac{1}{2}$	$\frac{5}{8}$	$\frac{3}{4}$	$\frac{7}{8}$	1	$1\frac{1}{8}$	$1\frac{1}{4}$	$1\frac{3}{8}$	$1\frac{1}{2}$
$1\frac{5}{8}$	19	.....	.....	.....	.....	.....	.....	.....	.....
$1\frac{3}{4}$	39	.....	.....	.....	.....	.....	.....	.....	.....
$1\frac{7}{8}$	47	17	.....	.....	.....	.....	.....	.....	.....
2	55	34	.....	.....	.....	.....	.....	.....	.....
$2\frac{1}{8}$	61	42	14	.....	.....	.....	.....	.....	.....
$2\frac{1}{4}$	65	50	30	.....	.....	.....	.....	.....	.....
$2\frac{3}{8}$	68	55	38	13	.....	.....	.....	.....	.....
$2\frac{1}{2}$	71	59	45	27	.....	.....	.....	.....	.....
$2\frac{5}{8}$	74	63	49	36	12	.....	.....	.....	.....
$2\frac{3}{4}$	76	67	56	43	26	.....	.....	.....	.....
$2\frac{7}{8}$	78	70	59	47	32	11	.....	.....	.....
3	80	73	62	50	38	23	.....	.....	.....
$3\frac{1}{8}$	81	74	65	55	44	30	10	.....	.....
$3\frac{1}{4}$	83	76	68	59	48	34	22	.....	.....
$3\frac{3}{8}$	84	78	71	62	51	40	29	9	.....
$3\frac{1}{2}$	85	80	73	64	53	45	34	20	.....
$3\frac{5}{8}$	86	81	75	66	57	49	38	26	9
$3\frac{3}{4}$	87	82	76	68	60	52	42	32	19
$3\frac{7}{8}$	87	83	78	70	63	55	46	36	25
4	88	84	79	72	66	58	49	40	29
$4\frac{1}{4}$	89	86	81	76	70	63	56	47	37
$4\frac{1}{2}$	90	87	83	79	73	67	61	54	45
$4\frac{3}{4}$	92	89	85	81	76	70	65	58	51
5	93	90	87	83	78	73	67	62	56
$5\frac{1}{2}$	94	92	89	86	82	78	73	68	63
6	95	93	91	88	85	82	78	74	69

**Piston-valve.** — The piston-valve is a modified form of the slide-valve. The lap, lead, etc., are calculated in the same manner as for the common slide-valve. The diameter of valve and amount of port-opening are calculated on the basis that the most contracted portion of the steam-passage between the valve and the cylinder should have an area such that the velocity of steam through it will not exceed 6000 ft. per minute. The area of the opening around the circumference of the valve should be about double the area of the steam-passage, since that portion of the opening that is opposite from the steam-passage is of little effect.

**Setting the Valves of an Engine.** — The principles discussed above are applicable not only to the designing of valves, but also to adjustment of valves that have been improperly set; but the final adjustment of the eccentric and of the length of the rod depends upon the amount of lost motion, temperature, etc.; and can be effected only after trial. After the valve has been set as accurately as possible when cold, the lead and lap for the forward and return strokes being equalized, indicator diagrams should be taken and the length of the eccentric-rod adjusted, if necessary, to correct slight irregularities.

**To Put an Engine on its Center.** — Place the engine in a position where the piston will have nearly completed its outward stroke, and opposite some point on the crosshead, such as a corner, make a mark upon the guide. Against the rim of the pulley or crank-disk place a pointer and mark a line with it on the pulley. Then turn the engine over the center until the crosshead is again in the same position on its inward stroke. This will bring the crank as much below the center as it was above it before. With the pointer in the same position as before make a second mark on the pulley rim. Divide the distance between the marks in two and mark the middle point. Turn the engine until the pointer is opposite this middle point, and it will then be on its center. To avoid

the error that may arise from the looseness of crank-pin and wrist-pin bearings, the engine should be turned a little above the center and then be brought up to it, so that the crank-pin will press against the same brass that it does when the first two marks are made.

**Link Motion.**—Link-motions, of which the Stephenson link is the most commonly used, are designed for two purposes: first, for reversing the motion of the engine, and second, for varying the point of cut-off by varying the travel of the valve. The Stephenson link-motion is a combination of two eccentrics, called forward and back eccentrics, with a link connecting the extremities of the eccentric-rods; so that by varying the position of the link the valve-rod may be put in direct connection with either eccentric, or may be given a movement controlled in part by one and in part by the other eccentric. When the link is moved by the reversing lever into a position such that the block to which the valve-rod is attached is at either end of the link, the valve receives its maximum travel, and when the link is in mid-gear the travel is the least and cut-off takes place early in the stroke.

In the ordinary shifting-link with open rods, that is, not crossed, the lead of the valve increases as the link is moved from full to mid-gear, that is, as the period of steam admission is shortened. The variation of lead is equalized for the front and back strokes by curving the link to the radius of the eccentric-rods concavely to the axles. With crossed eccentric-rods the lead decreases as the link is moved from full to mid-gear. In a valve-motion with stationary link the lead is constant. (For illustration see Clark's "Steam-engine," vol. ii, p. 22.)

The linear advance of each eccentric is equal to that of the valve in full gear, that is, to lap + lead of the valve, when the eccentric-rods are attached to the link in such position as to cause the half-travel of the valve to equal the eccentricity of the eccentric.

The angle between the two eccentric radii, that is, between lines drawn from the center of the eccentric disks to the center of the shaft, equals  $180^\circ$  less twice the angular advance.

Buel, in Appleton's "Cyclopedia of Mechanics," vol. ii, p. 316, discusses the Stephenson link as follows: "The Stephenson link does not give a perfectly correct distribution of steam; the lead varies for different points of cut-off. The period of admission and the beginning of exhaust are not alike for both ends of the cylinder, and the forward motion varies from the backward.

"The correctness of the distribution of steam by Stephenson's link-motion depends upon conditions which, as much as the circumstances will permit, ought to be fulfilled, namely: 1. The link should be curved in the arc of a circle whose radius is equal to the length of the eccentric-rod. 2. The eccentric-rods ought to be long, the longer they are in proportion to the eccentricity the more symmetrical will the travel of the valve be on both sides of the center of motion. 3. The link ought to be short. Each of its points describes a curve in a vertical plane, whose ordinates grow larger the farther the considered point is from the center of the link; and as the horizontal motion only is transmitted to the valve, vertical oscillation will cause irregularities. 4. The link-hanger ought to be long. The longer it is the nearer will be the arc in which the link swings to a straight line, and thus the less its vertical oscillation. If the link is suspended at its center, the curves that are described by points equidistant on both sides from the center are not alike, and hence results the variation between the forward and backward gears. If the link is suspended at its lower end, its lower half will have less vertical oscillation and the upper half more. 5. The center from which the link-hanger swings changes its position as the link is lowered or raised, and also causes irregularities. To reduce them to the smallest amount the arm of the lifting-shaft should be made as long as the eccentric-rod, and the center of the lifting-shaft should be placed at the height corresponding to the central position of the center on which the link-hanger swings."

All these conditions can never be fulfilled in practice, and the variations in the lead and the period of admission can be somewhat regulated in an artificial way, but for one gear only. This is accomplished by giving different lead to the two eccentrics, which difference will be smaller the longer the eccentric-rods are and the shorter the link, and by suspending

the link not exactly on its center line but at a certain distance from it, giving what is called "the offset."

For application of the Zeuner diagram to link-motion, see Holmes on the Steam-engine, p. 290. See also Clark's Railway Machinery (1855), Clark's Steam-engine, Zeuner's and Auchincloss's Treatises on Slide-valve Gears, and Halsey's Locomotive Link Motion. (See page 1119.)

The following rules are given by the *American Machinist* for laying out a link for an upright slide-valve engine. By the term radius of link is meant the radius of the link-arc, *ab*, Fig. 173, drawn through the center of the slot; this radius is generally made equal to the distance from the

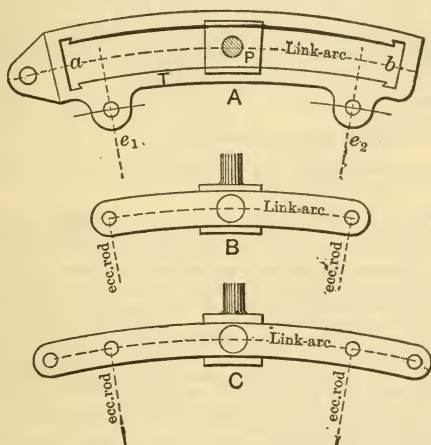

Fig. 173.

center of shaft to center of the link-block pin *P* when the latter stands midway of its travel. The distance between the centers of the eccentric-rod pins *e1 e2* should not be less than 2½ times, and, when space will permit, three times the throw of the eccentric. By the throw we mean twice the eccentricity of the eccentric. The slot link is generally suspended from the end next to the forward eccentric at a point in the link-arc prolonged. This will give comparatively a small amount of slip to the link-block when the link is in forward gear; but this slip will be increased when the link is in backward gear. This increase of slip is, however, considered of little importance, because marine engines, as a rule, work but very little in the backward gear. When it is necessary that the motion shall be as efficient in backward gear as in forward gear, then the link should be suspended from a point midway between the two eccentric-rod pins; in marine engine practice this point is generally located on the link-arc; for equal cut-offs it is better to move the point of suspension a small amount towards the eccentrics.

For obtaining the dimensions of the link in inches: Let *L* denote the length of the valve, *B* the breadth, *p* the absolute steam-pressure per sq. in., and *R* a factor of computation used as below; then  $R = 0.01 \sqrt{L \times B \times p}$

- Breadth of the link..... =  $R \times 1.6$
- Thickness *T* of the bar..... =  $R \times 0.8$
- Length of sliding-block..... =  $R \times 2.5$
- Diameter of eccentric-rod pins..... =  $(R \times 0.7) + 1/4$  in.
- Diameter of suspension-rod pin..... =  $(R \times 0.6) + 1/4$  in.
- Diameter of suspension-rod pin when overhung... =  $(R \times 0.8) + 1/4$  in.
- Diameter of block-pin when overhung..... =  $R + 1/4$  in.
- Diameter of block-pin when secured at both ends, =  $(R \times 0.8) + 1/4$  in.



The length of the link, that is, the distance from *a* to *b*, measured on a straight line joining the ends of the link-arc in the slot, should be such as to allow the center of the link-block pin *P* to be placed in a line with the eccentric-rod pins, leaving sufficient room for the slip of the block. Another type of link frequently used in marine engines is the double-bar link, and this type is again divided into two classes: one class embraces those links which have the eccentric-rod ends as well as the valve-spindle end between the bars, as shown at *B* (with these links the travel of the valve is less than the throw of the eccentric); the other class embraces those links, shown at *C*, for which the eccentric-rods are made with fork-ends, so as to connect to studs on the outside of the bars, allowing the block to slide to the end of the link, so that the centers of the eccentric-rod ends and the block-pin are in line when in full gear, making the travel of the valve equal to the throw of the eccentric. The dimensions of these links when the distance between the eccentric-rod pins is  $2\frac{1}{2}$  to  $2\frac{3}{4}$  times the throw of eccentrics can be found as follows:

Depth of bars.....	=	$(R \times 1.25) + \frac{1}{2}$ in.
Thickness of bars.....	=	$(R \times 0.5) + \frac{1}{4}$ in.
Diameter of center of sliding-block.....	=	$R \times 1.3$

When the distance between the eccentric-rod pins is equal to 3 or 4 times the throw of the eccentrics, then

Depth of bars.....	=	$(R \times 1.25) + \frac{3}{4}$ in.
Thickness of bars.....	=	$(R \times 0.5) + \frac{1}{4}$ in.

All the other dimensions may be found by the first table. These are empirical rules, and the results may have to be slightly changed to suit given conditions. In marine engines the eccentric-rod ends for all classes of links have adjustable brasses. In locomotives the slot-link is usually employed, and in these the pin-holes have case-hardened bushes driven into the pin-holes, and have no adjustable brasses in the ends of the eccentric-rods. The link in *B* is generally suspended by one of the eccentric-rod pins; and the link in *C* is suspended by one of the pins in the end of the link, or by one of the eccentric-rod pins. (See note on Locomotive Link Motion, p. 1119.)

**The Walschaerts Valve-gear.** Fig. 174.—This gear, which was invented in Belgium, has for many years been used on locomotives in Europe, and it has now (1909) come largely into use in the United States. The return crank *Q*, which takes the place of an eccentric, through the rod *B* oscillates the link on the fixed pin *F*. The block *D* is raised and lowered in the link by the reversing rod *I*, operating through the bell-

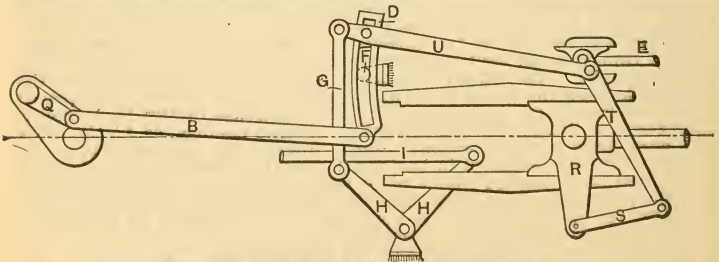

FIG. 174.—The Walschaerts Valve-gear.

crank levers *H, H*, and the supporting rod *G*. When the block is in its lowest position the radius rod *U* has a motion corresponding in direction to that of the rod *B*; when the block is at its upper position *U* moves in an opposite direction to *B*. The valve-rod *E* is moved by the combined action of *U* and a lever *T* whose lower end is connected through the rod *S* to the cross-head *R*. Constant lead is secured by this gear. (The main crank and the return crank should be shown in the cut as inclining to the right to correspond with the position of the cross-head.)

**Other Forms of Valve-gear,** as the Joy, Marshall, Hackworth, Bremme, Walschaerts, Corliss, etc., are described in Clark's Steam-engine, vol. ii. *Power*, May 11, 1909, illustrates the Stephenson, Gooch, Allen, Polenceau, Marshall, Joy, Waldegg, Walschaerts, Fink, and Baker-Pilliod gears. The design of the Reynolds-Corliss valve-gear is discussed by A. H. Eldridge in *Power*, Sept., 1893. See also Henthorn on the Corliss Engine. Rules for laying down the center lines of the Joy valve-gear are given in *American Machinist*, Nov. 13, 1890. For Joy's "Fluid-pressure Reversing-valve," see *Eng'g*, May 25, 1894.

## GOVERNORS.

**Pendulum or Fly-ball Governor.** — The inclination of the arms of a revolving pendulum to a vertical axis is such that the height of the point of suspension  $h$  above the horizontal plane in which the center of gravity of the balls revolves (assuming the weight of the rods to be small compared with the weight of the balls) bears to the radius  $r$  of the circle described by the centers of the balls the ratio

$$\frac{h}{r} = \frac{\text{weight}}{\text{centrifugal force}} = \frac{w}{\frac{wv^2}{gr}} = \frac{gr}{v^2},$$

which ratio is independent of the weight of the balls,  $v$  being the velocity of the centers of the balls in feet per second.

If  $T$  = number of revolutions of the balls in 1 second,  $v = 2\pi rT = ar$ , in which  $a$  = the angular velocity, or  $2\pi T$ , and

$$h = \frac{gr^2}{v^2} = \frac{g}{4\pi^2 T^2}, \text{ or } h = \frac{0.8146}{T^2} \text{ feet} = \frac{9.775}{T^2} \text{ inches,}$$

$g = 32.16$ . If  $N$  = revs. per minute,  $h = 35,190 \div N^2$ .

For revolutions per minute . . . . .	40	45	50	60	75
The height in inches will be . . .	21.99	17.38	14.08	9.775	6.256

Number of turns per minute required to cause the arms to take a given angle with the vertical axis: Let  $l$  = length of the arm in inches from the center of suspension to the center of gyration, and  $a$  the required angle; then

$$N = \sqrt{\frac{35190}{l \cos a}} = 187.6 \sqrt{\frac{1}{l \cos a}} = 187.6 \sqrt{\frac{l}{h}}.$$

The simple governor is not isochronous; that is, it does not revolve at a uniform speed in all positions, the speed changing as the angle of the arms changes. To remedy this defect loaded governors, such as Porter's, are used. From the balls of a common governor whose collective weight is  $A$  let there be hung by a pair of links of lengths equal to the pendulum arms a load  $B$  capable of sliding on the spindle, having its center of gravity in the axis of rotation. Then the centrifugal force is that due to  $A$  alone, and the effect of gravity is that due to  $A + 2B$ ; consequently the altitude for a given speed is increased in the ratio  $(A + 2B) : A$ , as compared with that of a simple revolving pendulum, and a given absolute variation in altitude produces a smaller proportionate variation in speed than in the common governor. (Rankine, S. E., p. 551.)

For the weighted governor let  $l$  = the length of the arm from the point of suspension to the center of gravity of the ball, and let the length of the suspending-link  $l_1$  = the length of the portion of the arm from the point of suspension of the arm to the point of attachment of the link;  $G$  = the weight of one ball,  $Q$  = half the weight of the sliding weight,  $h$  = the height of the governor from the point of suspension to the plane of revolution of the balls,  $a$  = the angular velocity =  $2\pi T$ ,  $T$  being the number of

revolutions per second; then  $a = \sqrt{\frac{32.16}{h} \left(1 + \frac{2l_1 Q}{l G}\right)}$ ;  $h = \frac{32.16}{a^2} \left(1 + \frac{2l_1 Q}{l G}\right)$  in feet, or  $h = \frac{35190}{N^2} \left(1 + \frac{2l_1 Q}{l G}\right)$  in inches,  $N$  being the number of revolutions per minute.

J. H. Barr gives  $h = \left(\frac{187.7}{N}\right)^2 \frac{B + 2W}{B}$ , in which  $B$  is the combined weight of the two balls and  $W$  the central weight.

For various forms of governor see App. Cyl. Mech., vol. ii, 61, and Clark's Steam-engine, vol. ii, p. 65.

**To Change the Speed of an Engine Having a Fly-ball Governor.** — A slight difference in the speed of a governor changes the position of its weights from that required for full load to that required for no load. It is evident therefore that, whatever the speed of the engine, the normal speed of the governor must be that for which the governor was designed; i.e., the speed of the governor must be kept the same. To change the speed of the engine the problem is to so adjust the pulleys which drive the governor that the engine at its new speed shall drive it just as fast as it was driven at its original speed. In order to increase the engine-speed we must decrease the pulley upon the shaft of the engine, i.e., the driver, or increase that on the governor, i.e., the driven, in the proportion that the speed of the engine is to be increased.

**Fly-wheel or Shaft-governors.** — At the Centennial Exhibition in 1876 there were shown a few steam-engines in which the governors were contained in the fly-wheel or band-wheel, the fly-balls or weights revolving around the shaft in a vertical plane with the wheel and shifting the eccentric so as automatically to vary the travel of the valve and the point of cut-off. This form of governor has since come into extensive use, especially for high-speed engines. In its usual form two weights are carried on arms the ends of which are pivoted to two points on the pulley near its circumference,  $180^\circ$  apart. Links connect these arms to the eccentric. The eccentric is not rigidly keyed to the shaft but is free to move transversely across it for a certain distance, having an oblong hole which allows of this movement. Centrifugal force causes the weights to fly towards the circumference of the wheel and to pull the eccentric into a position of minimum eccentricity. This force is resisted by a spring attached to each arm which tends to pull the weights towards the shaft and shift the eccentric to the position of maximum eccentricity. The travel of the valve is thus varied, so that it tends to cut off earlier in the stroke as the engine increases its speed. Many modifications of this general form are in use. In the Buckeye and the McIntosh & Seymour engines the governor shifts the eccentric around on the shaft so as to vary the angular advance. In the Sweet "Straight-line" engine and in some others a single weight and a single spring are used. For discussions of this form of governor see Hartnell, *Proc. Inst. M. E.*, 1882, p. 408; *Trans. A. S. M. E.*, ix, 300; xi, 1081; xiv, 92; xv, 929; Modern Mechanism, p. 399; Whitham's Constructive Steam Engineering; J. Begtrup, *Am. Mach.*, Oct. 19 and Dec. 14, 1893, Jan. 18 and March 1, 1894.

More recent references are: J. Richardson, *Proc. Inst. M. E.*, 1895 (includes electrical regulation of steam-engines); A. K. Mansfield, *Trans. A. S. M. E.*, 1894; F. H. Ball, *Trans. A. S. M. E.*, 1896; R. C. Carpenter, *Power*, May and June, 1898; Thos. Hall, *El. World*, June 4, 1898; F. M. Rites, *Power*, July, 1902; E. R. Briggs, *Am. Mach.*, Dec. 17, 1903

**The Rites Inertia Governor**, which is the most common form of the shaft governor at this date (1909), has a long bar, usually made heavy at the ends, like a dumb-bell, instead of the usual weights. This is carried on an arm of the fly-wheel by a pin located at some distance from the center line of the bar, and also at some distance from its middle point. To pins located at two other points are attached the valve-rod and the spring. The bar acts both by inertia and by centrifugal force. When the wheel increases its speed the inertia of the bar tends to make it fall behind, and thus to change the relative position of the fly-wheel arm and the bar, and to change the travel of the valve. A small book on "Shaft Governors" (Hill Pub. Co., 1908) describes and illustrates this and many other forms of shaft governors, and gives practical directions for adjusting them.

**Calculation of Springs for Shaft-governors.** (Wilson Hartnell, *Proc. Inst. M. E.*, Aug., 1882.) — The springs for shaft-governors may be conveniently calculated as follows, dimensions being in inches:

Let  $W$  = weight of the balls or weights, in pounds;

$r_1$  and  $r_2$  = the maximum and minimum radial distances of the center of the balls or of the centers of gravity of the weights;



$l_1$  and  $l_2$  = the leverages, i.e., the perpendicular distances from the center of the weight-pin to a line in the direction of the centrifugal force drawn through the center of gravity of the weights or balls at radii  $r_1$  and  $r_2$ ;

$m_1$  and  $m_2$  = the corresponding leverages of the springs;

$C_1$  and  $C_2$  = the centrifugal forces, for 100 revolutions per minute, at radii  $r_1$  and  $r_2$ ;

$P_1$  and  $P_2$  = the corresponding pressures on the spring;

(It is convenient to calculate these and note them down for reference.)

$C_3$  and  $C_4$  = maximum and minimum centrifugal forces;

$S$  = mean speed (revolutions per minute);

$S_1$  and  $S_2$  = the maximum and minimum number of revolutions per minute;

$P_3$  and  $P_4$  = the pressures on the spring at the limiting number of revolutions ( $S_1$  and  $S_2$ );

$P_4 - P_3 = D$  = the difference of the maximum and minimum pressures on the springs;

$V$  = the percentage of variation from the mean speed, or the sensitiveness;

$t$  = the travel of the spring;

$u$  = the initial extension of the spring;

$v$  = the stiffness in pounds per inch;

$w$  = the maximum extension =  $u + t$ .

The mean speed and sensitiveness desired are supposed to be given. Then

$$S_1 = S - \frac{SV}{100};$$

$$S_2 = S + \frac{SV}{100};$$

$$C_1 = 0.28 \times r_1 \times W;$$

$$C_2 = 0.28 \times r_2 \times W;$$

$$P_1 = C_1 \times \frac{l_1}{m_1};$$

$$P_2 = C_2 \times \frac{l_2}{m_2};$$

$$P_3 = P_1 \times \left(\frac{S_1}{100}\right)^2;$$

$$P_4 = P_2 \times \left(\frac{S_2}{100}\right)^2;$$

$$v = \frac{D}{t}, u = \frac{P_3}{v}, w = \frac{P_4}{v}.$$

It is usual to give the spring-maker the values of  $P_4$  and of  $v$  or  $w$ . To ensure proper space being provided, the dimensions of the spring should be calculated by the formulæ for strength and extension of springs, and the least length of the spring as compressed be determined.

$$\text{The governor-power} = \frac{P_3 + P_4}{2} \times \frac{t}{12}.$$

With a straight centripetal line, the governor-power

$$= \frac{C_3 + C_4}{2} \times \left(\frac{r_2 - r_1}{12}\right).$$

For a preliminary determination of the governor-power it may be taken as equal to this in all cases, although it is evident that with a curved centripetal line it will be slightly less. The difference  $D$  must be constant for the same spring, however great or little its initial compression. Let the spring be screwed up until its minimum pressure is  $P_5$ . Then to find the speed  $P_6 = P_5 + D$ ,

$$S_5 = 100 \sqrt{\frac{P_5}{P_1}}; \quad S_6 = 100 \sqrt{\frac{P_6}{P_2}}.$$

The speed at which the governor would be isochronous would be

$$100 \sqrt{\frac{D}{P_2 - P_1}}.$$

Suppose the pressure on the spring with a speed of 100 revolutions, at the maximum and minimum radii, was 200 lbs. and 100 lbs., respectively,

then the pressure of the spring to suit a variation from 95 to 105 revolutions will be  $100 \times \left(\frac{95}{100}\right)^2 = 90.2$  and  $200 \times \left(\frac{105}{100}\right)^2 = 220.5$ . That is, the increase of resistance from the minimum to the maximum radius must be  $220 - 90 = 130$  lbs.

The extreme speeds due to such a spring, screwed up to different pressures, are shown in the following table:

Revolutions per minute, balls shut.....	80	90	95	100	110	120
Pressure on springs, balls shut.....	64	81	90	100	121	144
Increase of pressure when balls open fully.....	130	130	130	130	130	130
Pressure on springs, balls open fully.....	194	211	220	230	251	274
Revolutions per minute, balls open fully.....	98	102	105	107	112	117
Variation, per cent of mean speed.....	10	6	5	3	1	-1

The speed at which the governor would become isochronous is 114.

Any spring will give the right variation at some speed; hence in experimenting with a governor the correct spring may be found from any wrong one by a very simple calculation. Thus, if a governor with a spring whose stiffness is 50 lbs. per inch acts best when the engine runs at 95, 90 being its proper speed, then  $50 \times \left(\frac{90}{95}\right)^2 = 45$  lbs. is the stiffness of spring required.

To determine the speed at which the governor acts best, the spring may be screwed up until the governor begins to "hunt" and then be slackened until it is as sensitive as is compatible with steadiness.

### CONDENSERS, AIR-PUMPS, CIRCULATING-PUMPS, ETC.

**The Jet Condenser.** — In practice the temperature in the hot-well varies from  $110^\circ$  to  $120^\circ$ , and occasionally as much as  $130^\circ$  is maintained. To find the quantity of injection-water per pound of steam to be condensed: Let  $T_1$  = temperature of steam at the exhaust pressure;  $T_0$  = temperature of the cooling-water;  $T_2$  = temperature of the water after condensation, or of the hot-well;  $Q$  = pounds of the cooling-water per lb. of steam condensed; then

$$Q = \frac{1114^\circ + 0.3 T_1 - T_2}{T_2 - T_0}.$$

Another formula is:  $Q = \frac{WH}{R}$ , in which  $W$  is the weight of steam condensed,  $H$  the units of heat given up by 1 lb. of steam in condensing, and  $R$  the rise in temperature of the cooling-water. This is applicable both to jet and to surface condensers.

**Quantity of Cooling-water.** — The quantity depends chiefly upon its initial temperature, which in Atlantic practice may vary from  $40^\circ$  in the winter of temperate zone to  $80^\circ$  in subtropical seas. To raise the temperature to  $100^\circ$  in the condenser will require three times as many thermal units in the former case as in the latter, and therefore only one-third as much cooling-water will be required in the former case as in the latter. It is usual to provide pumping power sufficient to supply 40 times the weight of steam for general traders, and as much as 50 times for ships stationed in subtropical seas, when the engines are compound. If the circulating pump is double-acting, its capacity may be  $\frac{1}{53}$  in the former and  $\frac{1}{42}$  in the latter case of the capacity of the low-pressure cylinder. (Seaton.)

The following table, condensed from one given by W. V. Terry in *Power*, Nov. 30, 1909, shows the amount of circulating water required under different conditions of vacuum, temperature of water entering the condenser, and drop. The "drop" is the difference between the temperature of steam due to a given vacuum and the temperature of the water leaving the condenser.

POUNDS OF CIRCULATING WATER PER POUND OF STEAM CONDENSED.

Vacuum. Ins.	Drop. Deg. F.	Injection Water Temperature, Deg. F.									
		45	50	55	60	65	70	75	80	85	90
29.0	6	37.5	45.7	58.3	80.8						
	12	47.8	61.8	87.5							
	18	65.7	95.5								
28.5	6	25.6	29.2	33.9	40.3	50.0	65.7	95.5			
	12	30.0	35.0	42.0	52.5	70.0					
	18	36.2	43.8	55.3	75.0						
28.0	6	21.5	23.9	26.9	30.9	36.3	43.8	55.3	75.0		
	12	24.4	27.7	31.8	37.5	45.7	58.3	80.8			
	18	28.4	32.8	38.9	47.8	61.8	87.5				
27.0	6	16.4	17.8	19.5	21.5	23.9	27.0	30.9	36.2	43.8	55.3
	12	18.1	19.8	21.9	24.4	27.7	31.8	37.5	45.7	58.3	80.8
	18	20.2	22.4	25.0	28.4	32.8	38.9	47.8	61.8	87.5	
26.0	6	14.0	15.0	16.2	17.5	19.1	21.0	23.4	26.3	30.0	35.0
	12	15.2	16.4	17.8	19.5	21.5	23.9	26.9	30.9	36.3	43.8
	18	16.8	18.1	19.8	21.9	24.4	27.7	31.8	37.5	45.7	58.3

**Ejector Condensers.** — For ejector or injector condensers (Bulkley's, Schutte's, etc.) the calculations for quantity of condensing-water is the same as for jet condensers.

**The Barometric Condenser** consists of a vertical cylindrical chamber mounted on top of a discharge pipe whose length is 34 ft. above the level of the hot well. The exhaust steam and the condensing water meet in the upper chamber, the water being delivered in such a manner as to expose a large surface to the steam. The external atmosphere maintains a column of water in the tube, as a column of mercury is maintained in a barometer, and no air pump is needed. The Bulkley condenser is the original form of the type. In some modern forms a small air pump draws from the chamber the residue of air which is not drawn out by the descending column of water, discharging it into the column below the chamber.

**The Surface Condenser — Cooling Surface.** — In practice, with the compound engine, brass condenser-tubes, 18 B.W.G. thick, 13 lbs. of steam per sq. ft. per hour, with the cooling-water at an initial temperature of 60°, is considered very fair work when the temperature of the feed-water is to be maintained at 120°. It has been found that the surface in the condenser may be half the heating surface of the boiler, and under some circumstances considerably less than this. In general practice the following holds good when the temperature of sea-water is about 60°:

Terminal pres., lbs., abs. . . . .	30	20	15	12½	10	8	6
Sq. ft. per I.H.P. . . . . .	3	2.50	2.25	2.00	1.80	1.60	1.50

For ships whose station is in the tropics the allowance should be increased by 20%, and for ships which occasionally visit the tropics 10% increase will give satisfactory results. If a ship is constantly employed in cold climates 10% less suffices. (Seaton, Marine Engineering.)

Whitham (Steam-engine Design, p. 283, also *Trans. A. S. M. E.*, ix, 431) gives the following:  $S = \frac{WL}{ck(T_1 - t)}$ , in which  $S$  = condensing-surface in

sq. ft.;  $T_1$  = temperature Fahr. of steam of the pressure indicated by the vacuum-gauge;  $t$  = mean temperature of the circulating water, or the arithmetical mean of the initial and final temperatures;  $L$  = latent heat of saturated steam at temperature  $T_1$ ;  $k$  = perfect conductivity of 1 sq. ft. of the metal used for the condensing-surface for a range of 1° F. (or 550 B.T.U. per hour for brass, according to Isherwood's experiments);  $c$  = fraction denoting the efficiency of the condensing-surface;  $W$  =



pounds of steam condensed per hour. From experiments by Loring and Emery, on U.S.S. Dallas,  $c$  is found to be 0.323, and  $ck = 180$ ; making the equation  $S = \frac{WL}{180(T_1 - t)}$ .

Whitham recommends this formula for designing engines having independent circulating-pumps. When the pump is worked by the main engine the value of  $S$  should be increased about 10%.

Taking  $T_1$  at  $135^\circ$  F., and  $L = 1020$ , corresponding to 25 in. vacuum, and  $t$  for summer temperatures at  $75^\circ$ , we have:  $S = \frac{1020W}{180(135 - 75)} = \frac{17W}{180}$ .

Much higher results than those quoted by Whitham are obtained from modern forms of condensers. The literature on the subject of condensers from 1900 to 1909 has been quite voluminous, and much difference of opinion as to rules of proportioning condensers is shown.

**Coefficient of Heat Transference in Condensers.** (Prof. E. Josse of Berlin. Condensed from an abstract in *Power*, Feb. 2, 1909. See also *Transmission of Heat from Steam to Water*, pages 587 to 589.)

The coefficient  $U$ , the number of heat units transferred per hour through 1 sq. ft. of metallic condenser wall when the temperature of the steam is  $1^\circ$  F. higher than that of the water, can be deduced from the formula

$$1/U = 1/A_1 + d/L + 1/A_2,$$

in which  $1/A_1$  is the resistance to transmission from steam to metal,  $1/A_2$  the resistance to transmission from metal to water, and  $d/L$  the resistance to transmission of heat through the metal,  $d$  being the usual thickness of condenser tubes (1 m.m. or 0.0393 in.). For this thickness the value of  $L$  is fairly well known and may be given as 18,430 for brass, 6,500 for copper, 11,270 for iron, 5740 for zinc, 11,050 for tin and 2660 for aluminum. The middle term  $d/L$  would have the value of  $1/18,430$  and be of comparatively little importance.

The term  $1/A_2$  is the most important and has been investigated with the aid of two concentric tubes, water being sent both through the inner tube and the annular jacket. The values of various experimenters differ greatly. Ser gives the approximate formula

$$A - 2 = 510 \sqrt{V},$$

where  $V$  is the velocity of water through the tubes in ft. per sec. This velocity is far more important than the material of the condenser tubes and their thickness, and also of greater consequence than the velocity of the steam, about which, or, rather, the term  $1/A_1$ , there is even less agreement. Prof. Josse adopts the figure 3900. The velocity of the steam has its influence, but the whole term does not count for much. For water flowing at the rate of 1.64 ft. per sec. Josse's formula would be:

$$1/U = 1/3900 + 1/18,430 + 1/653 = 1/445,$$

and  $U = 445$ .

If  $A_1$  be increased to twice its value  $U$  would rise only to 475, and if the tube thickness be doubled  $U$  would hardly be affected. An increase, however, in the rate of flow of water from 1.64 to 5 feet per second would raise  $U$  to 625. As an increase of the steam flow is undesirable the best plan is to accelerate the flow of the circulating water, and by introducing the baffle strips or retarders into his condenser tubes, in order to break the water currents up into vortices, Josse raised the value of  $U$  at a velocity of 3.28 feet per second from 614 to 922.

Opinions differ concerning the increase of  $U$  with greater differences of temperature. According to some the heat transferred should increase proportionately to the difference; according to Weiss and others, proportionally to the square of the temperature differences. Josse's investigations were conducted by placing thermo couples in different portions of the condenser tubes. If the heat transferred increases as a linear function of the difference, then the rise of the temperature in the cooling water should follow an exponential law, and it was found to be so.

Curves showing the relation of the extent of surface to the temperatures of steam and water show an agreement with the formula

$$\text{Surface} = S = \frac{Q}{U} \log_e \frac{t_s - t_e}{t_g - t}$$

where  $t_g$  is the saturation temperature and  $t_e$  the temperature of the cooling-water at entrance,  $t$  being the discharge temperature.

*Air Leakage.* — Air passes into the condenser with the exhaust steam, the temperature of the air being that of the steam; the pressure of the mixture will be the sum of the partial steam pressure and of the partial air pressure. The air must be withdrawn by the air-pump. If the withdrawal takes place at the temperature corresponding to the condenser pressure the partial steam pressure would be equal to the condenser pressure, and the pump would have to deal with an enormous air volume. The air temperature should, therefore, be lowered, at the spot where the air is withdrawn, below the saturation temperature of the condenser pressure.

In steam turbines it is more easy to keep air out than in reciprocating engines. Experiments with a 300-kw. Parsons turbine show that not more than  $1\frac{1}{2}$  lb. of air was delivered per hour when 6600 lbs. of steam was used per hour.

*Condenser Pumps.* — The air and condensed water may either be removed separately, by a so-called dry-air pump, or both together, by a wet-air pump. As dry-air pumps have to deal with high compression ratios, with high vacua and single-stage pumps, the clearances must be small. When the clearance amounts to 5% the vacuum cannot be maintained at more than 95%, and the clearance must be reduced, or other expedients adopted. Three are mentioned: (1) the air-pump may be built in two stages; (2) the pump may be fitted with an equalizing pipe so that the two sides of the piston are connected near the end of each stroke; the volumetric efficiency is raised by this expedient, but considerably more power is absorbed to accomplish the result; (3) with the wet-air pump the clearance space is made to receive the condensed water, which will fill at least part of it.

*Contraflow and Ordinary Flow.* — Prof. Josse questions the distinction between contraflow and ordinary flow. For the greater portion of the condenser there is a rise of temperature only on the water side; the temperature of the steam side remains that of the saturated steam, and the term "contraflow" should, strictly speaking, only be applied if there is a temperature fall in the one direction and a corresponding temperature rise in the opposite direction. As far as the condensation is concerned, it is immaterial in which direction the water flows. The contraflow principle is, however, correct and necessary for the smaller portion of the condenser in which the condensed liquid is cooled together with the air; for the air must be withdrawn from the coldest spot. It seems inadvisable to attempt to direct the flow of the steam on the contraflow principle, as that would obstruct the steam flow and create a pressure difference between different portions of the condenser which would be injurious to the maintenance of high vacua.

*The Power Used for Condensing Apparatus* varies from about  $1\frac{1}{2}$  to 5% of the indicated power of the main engine, depending on the efficiency of the apparatus, on the degree of vacuum obtained, the temperature of the cooling-water, the load on the engine, etc. J. R. Bibbins (*Power*, Feb., 1905) gives the records of test of a 300-kw. plant from which the following figures are taken. Cooling-water per lb. of steam 32 to 37 lbs. Vacuum 27.3 to 27.8 ins. Temp. cooling-water 73. Hot-well 102 to 105.

Indicated H.P.....	151	220	238	260	291	294	457	589
% of total power used...	4.69	3.51	3.22	3.22	3.08	2.97	2.80	2.47
% for air cylinder.....	1.63	1.36	1.27	1.21	1.19	1.09	0.95	0.85
% for water pump.....	3.07	2.14	1.95	2.00	1.90	1.89	1.85	1.52

*Vacuum, ins. of Mercury, and Absolute Pressures.* — The vacuum as shown by a mercury column is not a direct measure of pressure, but only of the difference between the atmospheric pressure and the absolute pressure in the vacuum chamber. Since the atmospheric pressure varies with the altitude and also with atmospheric conditions, it is necessary when accuracy is desired to give the reading of the barometer as well as that of the vacuum gauge, or preferably to give the absolute pressure in lbs. per sq. in. above a perfect vacuum.

**Temperatures, Pressures and Volumes of Saturated Air.**—(D. B. Morison, on the influence of Air on Vacuum in Surface Condensers, *Eng'g*, April 17, 1908.)

VOLUME OF 1 LB. OF AIR WITH ACCOMPANYING VAPOR.

Temp. T° F.	Pressure at T° F.	Vacuum, ins. of Mercury, and lbs. absolute.													
		24 in., 2.947.		26 in., 1.962.		27 in., 1.474.		28 in., 0.9823.		28.5 in., 0.7368.		28.8 in., 0.5894.		29 in., 0.4912.	
		P	V	P	V	P	V	P	V	P	V	P	V	P	V
50	0.17	2.78	68	1.79	105	1.30	147	0.81	233	0.57	336	0.42	450	0.32	592
60	0.25	2.70	71	1.71	113	1.22	158	0.73	263	0.49	393	0.34	566	0.24	800
70	0.36	2.59	75	1.60	124	1.11	178	0.62	315	0.38	520	0.23	852	0.13	1536
80	0.50	2.45	81	1.46	137	0.97	204	0.48	420	0.24	832	0.09	(d)	.....	.....
90	0.69	2.26	90	1.27	163	0.78	260	0.29	700	0.05	(c)	.....	.....	.....	.....
100	0.94	2.01	103	1.02	203	0.53	390	0.042	(b)	.....	.....	.....	.....	.....	.....
110	1.26	1.69	125	0.70	304	0.21	(a)	.....	.....	.....	.....	.....	.....	.....	.....
120	1.68	1.27	170	0.28	770	.....	.....	.....	.....	.....	.....	.....	.....	.....	.....

P = partial pressure of air, lbs. per sq. in. V = volume of 1 lb. of air with accompanying vapor, cu. ft. (a) over 1000; (b) nearly 5000; (c) about 4000; (d) over 2000.

TEMPERATURES AND PRESSURES OF SATURATED AIR.

Vacuum, Ins. with Barom. at 30 in.	Proportions of Air and Steam by Weight.				
	Saturated Steam.	Air, 0.25. Steam, 1.	Air, 0.5. Steam, 1.	Air, 0.75. Steam, 1.	Air, 1. Steam, 1.
29	79.5° F.	75	71	67.5	64.5
28	101.5	96.5	92.4	88.8	85.3
27	115	110	105.6	101.7	98.6
26	126	120.2	115.5	111.5	108.3
25	134	128.4	123.5	119.2	116.2
24	141	135.2	130.3	125.8	122.3

From this table it is seen that a temperature of 126° F. corresponds to a 24-in. vacuum if the steam in the condenser has 75% of its weight of air mingled with it, and to a 26-in. vacuum if it is free from air.

One cubic foot of air measured at 60° F. and atmospheric pressure becomes 10 cu. ft. at 27 in. and 30 cu. ft. at 29 in. vacuum at the same temperature; 10.9 cu. ft. at 105° and 27 in.; 30.5 cu. ft. at 70° F. and 29 in. The same cu. ft. of air saturated with water vapor at 70° F. and 29 in. becomes 124.3 cu. ft., or 44.9 cu. ft. at 105° and 27 in. vacuum. The temperatures 105° and 70° are about 10% below the temperatures of saturated steam at 27 in. and 29 in. respectively.

**Condenser Tubes** are generally made of solid-drawn brass tubes, and tested both by hydraulic pressure and steam. They are usually made of a composition of 68% of best selected copper and 32% of best Silesian spelter. The Admiralty, however, always specify the tubes to be made of 70% of best selected copper and to have 1% of tin in the composition, and test the tubes to a pressure of 300 lbs. per sq. in. (Seaton.)

The diameter of the condenser tubes varies from 1/2 in. in small condensers, when they are very short, to 1 in. in very large condensers and long tubes. In the mercantile marine the tubes are, as a rule, 3/4 in. diam. externally, and 18 B.W.G. thick (0.049 inch); and 16 B.W.G. (0.065), under some exceptional circumstances. In the British Navy the tubes are also, as a rule, 3/4 in. diam., and 18 to 19 B.W.G., tinned on both sides; when the condenser is brass the tubes are not required to be tinned. Some of the smaller engines have tubes 5/8 in. diam., and 19 B. W. G. The smaller the tubes, the larger is the surface which can be put in a certain space. (Seaton.)

In the merchant service the almost universal practice is to circulate the water through the tubes.

Whitham says the velocity of flow through the tubes should not be less than 400 nor more than 700 ft. per min.



**Tube-plates** are usually made of brass. Rolled-brass tube-plates should be from 1.1 to 1.5 times the diameter of tubes in thickness, depending on the method of packing. When the packings go completely through the plates, the latter thickness, but when only partly through, the former, is sufficient. Hence, for  $\frac{3}{4}$ -in. tubes the plates are usually  $\frac{7}{8}$  to 1 in. thick with glands and tape-packings, and 1 to  $1\frac{1}{4}$  ins. thick with wooden ferrules. The tube-plates should be secured to their seatings by brass studs and nuts, or brass screw-bolts; in fact there must be no wrought iron of any kind inside a condenser. When the tube-plates are of large area it is advisable to stay them by brass rods, to prevent them from collapsing.

**Spacing of Tubes, etc.**—The holes for ferrules, glands, or india-rubber are usually  $\frac{1}{4}$  inch larger in diameter than the tubes; but when absolutely necessary the wood ferrules may be only  $\frac{3}{32}$  inch thick.

The pitch of tubes when packed with wood ferrules is usually  $\frac{1}{4}$  inch more than the diameter of the ferrule-hole. For example, the tubes are generally arranged zigzag, and the number which may be fitted into a square foot of plate is as follows:

Pitch of Tubes, In.	No. in a Sq. Ft.	Pitch of Tubes, In.	No. in a Sq. Ft.	Pitch of Tubes, In.	No. in a Sq. Ft.
1	172	$1\frac{5}{32}$	128	$1\frac{1}{4}$	110
$1\frac{1}{16}$	150	$1\frac{3}{16}$	121	$1\frac{9}{32}$	106
$1\frac{1}{8}$	137	$1\frac{7}{32}$	116	$1\frac{5}{16}$	99

**Air-Pump.**—The air-pump in all condensers abstracts the water condensed and the air originally contained in the water when it entered the boiler. In the case of jet-condensers it also pumps out the water of condensation and the air which it contained. The size of the pump is calculated from these conditions, making allowance for efficiency of the pump.

In surface condensation allowance must be made for the water occasionally admitted to the boilers to make up for waste, and the air contained in it, also for slight leaks in the joints and glands, so that the air-pump is made about half as large as for jet-condensation.

Seaton says: The efficiency of a single-acting air-pump is generally taken at 0.5 and that of a double-acting pump at 0.35. When the temperature of the sea is  $60^\circ$ , and that of the (jet) condenser is  $120^\circ$ ,  $Q$  being the volume of the cooling-water and  $q$  the volume of the condensed water in cubic feet, and  $n$  the number of strokes per minute,

The volume of the single-acting pump =  $2.74 (Q + q) \div n$ .

The volume of the double-acting pump =  $4 (Q + q) \div n$ .

W. H. Booth, in his "Treatise on Condensing Plant," says the volume to be generated by an air-pump bucket should not be less than 0.75 cu. ft. per pound of steam dealt with by the condensing plant. Mr. R. W. Allen has made tests with as little air-pump capacity as 0.5 cu. ft. and he gives 0.6 cu. ft. as a minimum. An Edwards pump with three 14-in. barrels, 12-in. stroke, single-acting, 150 r.p.m., is rated at 45,000 lbs. of steam per hour from a surface condenser, which is equivalent to 0.66 cu. ft. per pound of feed-water.

In the Edwards pump, the base of the pump and the bottom of the piston are conical in shape. The water from the condenser flows by gravity into the space below the piston, which descending projects it through ports into the space in the barrel above the piston, whence on the ascending stroke of the piston it is discharged through the outlet valves. There are no bucket or foot-valves, and the pump may be run at much higher speeds than older forms of pump. (See Catalogue of the Wheeler Condenser and Engineering Co.)

**The Area through Valve-seats** and past the valves should not be less than will admit the full quantity of water for condensation at a velocity not exceeding 400 ft. per minute. In practice the area is generally in excess of this. (Seaton.)

Area through foot-valves =  $D^2 \times S \div 1000$  square inches.

Area through head-valves =  $D^2 \times S \div 800$  square inches.

Diameter of discharge-pipe =  $D \times \sqrt{S} \div 35$  inches.

$D$  = diam. of air-pump in inches,  $S$  = its speed in ft. per min.

James Tribe (*Am. Mach.*, Oct. 8, 1891) gives the following rule for air-

pumps used with jet-condensers: Volume of single-acting air-pump driven by main engine = volume of low-pressure cylinder in cubic feet, multiplied by 3.5 and divided by the number of cubic feet contained in one pound of exhaust steam of the given density. For a double-acting air-pump the same rule will apply, but the volume of steam for each stroke of the pump will be but one-half. Should the pump be driven independently of the engine, then the relative speed must be considered. Volume of jet-condenser = volume of air-pump  $\times 4$ . Area of injection valve = vol. of air-pump in cubic inches  $\div 520$ .

**The Work done by an Air-pump**, per stroke, is a maximum theoretically, when the vacuum is between 21 and 22 ins. of mercury. Assuming adiabatic compression, the mean effective pressure per stroke is  $P = 3.46 p_1 \left[ \left( \frac{p_2}{p_1} \right)^{0.29} - 1 \right]$ , where  $p$  = absolute pressure of the vacuum and  $p_2$  the terminal, or atmospheric, pressure, = 14.7 lbs. per sq. in. The horse-power required to compress and deliver 1 cu. ft. of air per minute, measured at the lower pressure, is, neglecting friction,  $P \times 144 \div 33,000$ .

The following table is calculated from these formulæ (R. R. Pratt, *Power* Sept. 7, 1909).

Vac. in Ins. of Mer- cury.	Abs. Press., Ins. of Mer- cury.	$\frac{p_2}{p_1}$	Theo- retic. M.E.P.	Theo- retic. H.P.	Vac. in Ins. of Mer- cury.	Abs. Press., Ins. of Mer- cury.	$\frac{p_2}{p_1}$	Theo- retic. M.E.P.	Theo- retic. H.P.
29	1	30.00	2.86	0.0124	18	12	2.50	6.21	0.0271
28	2	15.00	4.05	0.0177	16	14	2.14	5.89	0.0256
27	3	10.00	4.83	0.0211	14	16	1.87	5.42	0.0236
26	4	7.50	5.40	0.0235	12	18	1.67	4.88	0.0212
25	5	6.00	5.78	0.0252	10	20	1.50	4.23	0.0184
24	6	5.00	6.05	0.0264	8	22	1.36	3.52	0.0153
23	7	4.28	6.23	0.0271	6	24	1.25	2.73	0.0119
22	8	3.75	6.33	0.0276	4	26	1.15	1.88	0.0082
21	9	3.33	6.37	0.0278	2	28	1.07	0.96	0.0042
20	10	3.00	6.36	0.0277	1	29	1.03	0.49	0.0021

The work done by the air-pump is to compress the saturated mixture of air and water vapor at the condenser pressure to atmospheric pressure and to discharge it into the atmosphere together with the water of condensation (and with the cooling water in the case of jet condensers operated with an air-pump). The amount of air to be discharged varies with the amount of air in the feed-water and with the leakage of air through the stuffing-boxes. Geo. A. Orrok (*Jour. A. S. M. E.*, 1912, p. 1625) found the volume of air in city water at 52 deg. F. to be over 4 per cent; and in feed-water at 187 degrees less than 1 per cent. With turbines of from 5,000 to 20,000 kw. capacity the air discharged by the air-pump at atmospheric pressure and temperature varied from 1 cu. ft. per min. with the units in the best condition to 15 or 20 when ordinary leakage was present, or to 30 to 50 when the units were in bad condition. Stodola states that we may ordinarily expect the air to amount to 1.5 to 2.5 cu. ft. per min. for each 1000 kw. capacity. T. C. McBride (*Power*, July 14, 1908) gives results of tests in which the amount of air varied from 18 to 74 volumes per 10,000 volumes of exhaust steam. C. L. W. Trinks (*Proc. Engrs. Soc. of W. Penna.*, June, 1914) gives the weight of air normally expected by builders of air-pumps as 0.25 to 0.50 per cent of the weight of steam.

W. H. Herschel (*Power*, June 1, 1915), after quoting the above figures, gives the results of calculations based upon assumed air leakages of 20, 40, and 60 volumes of air per 10,000 volumes of steam, corresponding respectively to 0.31, 0.62, and 0.93 per cent of the weight of steam, or approximately to 15, 30, and 45 cu. ft. per min. for every 1000 kw. capacity, the smallest amount being that which may be obtained with stuffing-boxes in the best condition, while the largest value may be reached, or even exceeded, with stuffing-boxes in poor condition. Following are his figures for the extreme conditions:

TOTAL WORK OF AN AIR-PUMP, INCLUDING DISCHARGE OF COOLING WATER.

Temp. of Cooling Water.	Vacuum, In., Leakage 0.31%.					Temp. of Cooling Water.	Vacuum, In., Leakage 0.93%.				
	29	28.5	28	27	26		29	28.5	28	27	26
	Temperature of Condenser °F.						Temperature of Condenser °F.				
32°	63	71	78	87	96	32°	55	62	68	77	77
50°	68	77	83	92	100	50°	64	71	78	85	91
60°	71	79	86	96	104	60°	68	75	82	88	96
70°	76	83	89	100	109	70°	72	80	86	95	103
80°	.....	86	94	104	111	80°	.....	82	92	99	106
Ft.-lb. Work per Lb. Steam Condensed.						Ft.-lb. Work per Lb. Steam Condensed.					
32°	2150	1560	1280	1000	840	32°	3840	2880	2380	1840	1530
50°	3300	2120	1650	1210	990	50°	5760	3730	2920	2150	1760
60°	4820	2740	2000	1410	1120	60°	8440	4720	3450	2440	1960
70°	8220	4010	2670	1700	1280	70°	13250	6610	4410	2850	2210
80°	.....	7750	3930	2110	1530	80°	.....	11330	6960	3520	2560
Lb. Cooling Water per Lb. Steam.						Lb. Cooling Water per Lb. Steam.					
32°	32.1	25.6	21.7	18.2	15.6	32°	42.7	32.8	28.0	24.5	21.5
50°	55.0	36.7	30.2	24.7	19.9	50°	70.8	47.3	35.5	28.6	24.5
60°	89.8	52.3	37.9	27.5	22.6	60°	123.8	66.0	45.1	35.7	27.8
70°	164.0	75.8	52.2	32.8	25.2	70°	494.0	98.8	61.8	39.6	30.1
80°	.....	164.0	70.0	41.0	31.8	80°	.....	493.0	82.0	52.0	38.1

**Most Economical Vacuum for Turbines.**—Mr. Herschel, taking the air-pump work given in the above table for the several conditions named, an efficiency of 50 per cent for the air-pump, and assuming a turbine working with dry steam 150-lb. gage, without superheat, calculates the net work of the turbine in foot-pounds per lb. of steam with the most economical vacuum for different temperatures of cooling water. He compares the results with those calculated for the same air-pump conditions, but for a turbine using steam of 140 lb. superheated 218° F. The results are tabulated below, the vacuum giving the best economy being given in parentheses. The lines marked S are for the superheated steam turbine. It appears that 29 in. vacuum is the most economical only for low temperatures of cooling water, and that the vacuum giving the best economy decreases with increase of leakage and with increasing temperature of the cooling water.

Temperature of cooling water, °F.		32	50	60	70	80
Net Work of Turbine, Ft.-lb. per Lb. of Steam.						
Leakage of air, % weight of steam.	0.31%	S. 56000(29)	53700(29)	52120(28.5)	50360(28)	48980(27)
		S. 76200(29)	73900(29)	71620(28.5)	69080(28.5)	65240(28)
	0.93%	S. 52620(29)	50140(28.5)	48800(28)	47500(27)	46160(27)
		S. 72820(29)	69640(28.5)	67660(28.5)	64280(28)	62060(27)

**Circulating-pump.**—Let  $Q$  be the quantity of cooling-water in cubic feet,  $n$  the number of strokes per minute, and  $S$  the length of stroke in feet.

$$\text{Capacity of circulating-pump} = Q \div n \text{ cubic feet.}$$

$$\text{Diameter of circulating-pump} = 13.55 \sqrt{Q \div nS} \text{ inches.}$$

The clear area through the valve-seats and past the valves should be such that the mean velocity of flow does not exceed 450 feet per minute. The flow through the pipes should not exceed 500 ft. per min. in small pipes and 600 in large pipes. (Seaton.)

For Centrifugal Circulating-pumps, the velocity of flow in the inlet and outlet pipes should not exceed 400 ft. per min. The diameter of the fan-wheel is from 2 1/2 to 3 times the diam. of the pipe, and the speed at its periphery 450 to 500 ft. per min.



**The Leblanc Condenser** (made by the Westinghouse Machine Co.) accomplishes the separate removal of water and air by means of a pair of relatively small turbine-type rotors on a common shaft in a single casing, which is integral with or attached directly to the lower portion of the condensing chamber. The condensing chamber itself is but little more than an enlargement of the exhaust pipe. The injection water is projected downwards through a spray nozzle, and the combined injection water and condensed steam flow downward to a centrifugal discharge pump under a head of 2 or 3 ft., which insures the filling of the pump. The space above the water level in the condensing chamber is occupied by water vapor plus the air which entered with the injection water and with the exhaust steam, and this space communicates with the air-pump through a relatively small pipe.

The air-pump differs from pumps of the ejector type in that the vanes in traversing the discharge nozzle at high speed constitute a series of pistons, each one of which forces ahead of it a small pocket of air, the high velocity of which effectually prevents its return to the condenser. A small quantity of water is supplied to the suction side of the air-pump to assist in the performance of its functions. The power required for the pumps is said to approximate 2 to 3 per cent of the power generated by the main engine.

**Feed-pumps for Marine Engines.**— With surface-condensing engines the amount of water to be fed by the pump is the amount condensed from the main engine plus what may be needed to supply auxiliary engines and to supply leakage and waste. Since an accident may happen to the surface-condenser, requiring the use of jet-condensation, the pumps of engines fitted with surface-condensers must be sufficiently large to do duty under such circumstances. With jet-condensers and boilers using salt water the dense salt water in the boiler must be blown off at intervals to keep the density so low that deposits of salt will not be formed. Sea-water contains about  $\frac{1}{32}$  of its weight of solid matter in solution. The boiler of a surface-condensing engine may be worked with safety when the quantity of salt is four times that in sea-water. If  $Q$  = net quantity of feed-water required in a given time to make up for what is used as steam,  $n$  = number of times the saltiness of the water in the boiler is to that of sea-water, then the gross feed-water =  $nQ \div (n-1)$ . In order to be capable of filling the boiler rapidly each feed-pump is made of a capacity equal to twice the gross feed-water. Two feed-pumps should be supplied, so that one may be kept in reserve to be used while the other is out of repair. If  $Q$  be the quantity of net feed-water in cubic feet,  $l$  the length of stroke of feed-pump in feet, and  $n$  the number of strokes per minute,

$$\text{Diameter of each feed-pump plunger in inches} = \sqrt{550 Q \div nl.}$$

If  $W$  be the net feed-water in pounds,

$$\text{Diameter of each feed-pump plunger in inches} = \sqrt{8.9 W \div nl.}$$

**An Evaporative Surface Condenser** built at the Virginia Agricultural College is described by James H. Fitts (*Trans. A. S. M. E.*, xiv, 690). It consists of two rectangular end chambers connected by a series of horizontal rows of tubes, each row of tubes immersed in a pan of water. Through the spaces between the surface of the water in each pan and the bottom of the pan above air is drawn by means of an exhaust-fan. At the top of one of the end chambers is an inlet for steam, and a horizontal diaphragm about midway causes the steam to traverse the upper half of the tubes and back through the lower. An outlet at the bottom leads to the air-pump. The passage of air over the water surfaces removes the vapor as it rises and thus hastens evaporation. The heat necessary to produce evaporation is obtained from the steam in the tubes, causing the steam to condense. It was designed to condense 800 lbs. steam per hour and give a vacuum of 22 in., with a terminal pressure in the cylinder of 20 lbs. absolute. Results of tests show that the cooling-water required is practically equal in amount to the steam used by the engine. And since the consumption of steam is reduced by the application of a condenser, its use will actually reduce the total quantity of water required.

**The Continuous Use of Condensing-water** is described in a series of articles in *Power*, Aug.-Dec., 1892. It finds its application in situations where water for condensing purposes is expensive or difficult to obtain.

The different methods described include cooling pans on the roof; fountains and other spray pipes in ponds, fine spray discharged at an elevation above a pond; trickling the water discharged from the hot-well over parallel narrow metal tanks contained in a large wooden structure, while a fan blower drives a current of air against the films of water falling from the tanks, etc. These methods are suitable for small powers, but for large powers they are cumbersome and require too much space, and are practically supplanted by cooling towers.

The Increase of Power that may be obtained by adding a condenser giving a vacuum of 26 inches of mercury to a non-condensing engine may

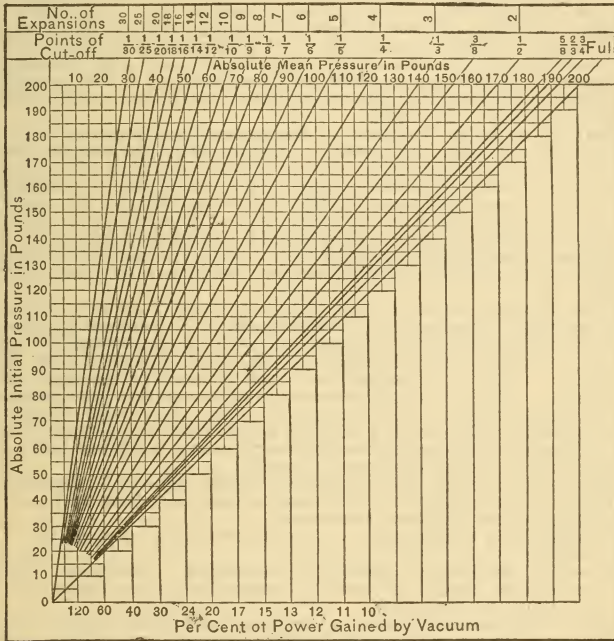

Fig. 175.

be approximated by considering it to be equivalent to a net gain of 12 lbs. mean effective pressure per sq. in. of piston area. If  $A$  = area of piston in sq. ins.,  $S$  = piston speed in ft. per min., then  $12 AS \div 33,000 = AS \div 2750 = \text{H.P. made available by the vacuum}$ . If the vacuum = 13.2 lbs. per sq. in. = 27.9 in. of mercury, then  $\text{H.P.} = AS \div 2500$ .

The saving of steam for a given horse-power will be represented approximately by the shortening of the cut-off when the engine is run with the condenser. Clearance should be included in the calculation. To the mean effective pressure non-condensing, with a given actual cut-off, clearance considered, add 3 lbs. to obtain the approximate mean total pressure, condensing. From tables of expansion of steam find what actual cut-off will give this mean total pressure. The difference between this and the original actual cut-off, divided by the latter and by 100, will give the percentage of saving.

The diagram, Fig. 175 (from catalogue of H. R. Worthington) shows the percentage of power that may be gained by attaching a condenser to a non-condensing engine assuming that the vacuum is 12 lbs. per sq.

in. The diagram also shows the mean pressure in the cylinder for a given initial pressure and cut-off, clearance and compression not considered.

The pressures given in the diagram are absolute pressures above a vacuum.

To find the mean effective pressure produced in an engine cylinder with 90 lbs. gauge (= 105 lbs. absolute) pressure, cut-off at  $\frac{1}{4}$  stroke: find 105 in the left-hand or initial-pressure column, follow the horizontal line to the right until it intersects the oblique line that corresponds to the  $\frac{1}{4}$  cut-off, and read the mean total pressure from the row of figures directly above the point of intersection, which in this case is 63 lbs. From this subtract the mean absolute back pressure (say 3 lbs. for a condensing engine and 15 lbs. for a non-condensing engine exhausting into the atmosphere) to obtain the mean effective pressure, which in this case, for a non-condensing engine, gives 48 lbs. To find the gain of power by the use of a condenser with this engine, read on the lower scale the figures that correspond in position to 48 lbs. in the upper row, in this case 25%. As the diagram does not take into consideration clearance or compression, the results are only approximate.

**Advantage of High Vacuum in Reciprocating Engines.** (R. D. Tomlinson, *Power*, Feb. 23, 1909.) — Among the transatlantic liners, the best ships with reciprocating engines are carrying from 26 to 28 and more inches of vacuum. Where the results are looked into, the engineers are required to keep the vacuum system tight and carry all the vacuum they can get, and while it is true that greater benefits can be derived from high vacua in a steam turbine than in a reciprocating engine, it is also true that, where primary heaters are not used, the higher the vacuum carried the greater is the justifiable economy which can be obtained from the plant.

The Interborough Rapid Transit Company, New York City, changed the motor-driven air-pump and jet-condenser for a barometric type of condenser and increased the vacuum on each of the 8000-H.P. Allis-Chalmers horizontal vertical engines at the 74th Street station from 26 to 28 ins., thereby increasing the power on each of the eight units approximately 275 H.P., and the economy of the station was increased nearly in the same ratio. This change was made about seven years ago and the plant is still operating with 28 ins. of vacuum, measured with mercury columns connected to the exhaust pipe at a point just below the exhaust nozzle of the low-pressure cylinders.

A careful test made on the 59th Street station showed a decrease in steam consumption of 8% when the vacuum was raised from 25 to 28 ins. These engines drive 5000-kw. generators.

**The Choice of a Condenser.** — Condensers may be divided into two general classes:

First. — Jet condensers, including barometric condensers, siphon condensers, ejector condensers, etc., in which the cooling-water mingles with the steam to be condensed.

Second. — Surface condensers, in which the cooling-water is separated from the steam, the cooling-water circulating on one side of this surface and the steam coming into contact with the other.

In the jet-condenser the steam, as soon as condensed, becomes mixed with the cooling-water, and if the latter should be unsuitable for boiler-feed because of scale-forming impurities, acids, salt, etc., the pure distilled water represented by the condensed steam is wasted, and, if it were necessary to purchase other water for boiler-feeding, this might represent a considerable waste of money. On the other hand, if the cooling-water is suitable for boiler-feeding, or if a fresh supply of good water is easily obtainable, the jet-condenser, because of its simplicity and low cost, is unexcelled.

Surface condensers are recommended where the cooling-water is unfitted for boiler-feed and where no suitable and cheap supply of pure boiler-feed is available.

Where a natural supply of cooling-water, as from a well, spring, lake or river, is not available, a water-cooling tower can be installed and the same cooling-water used over and over. (Wheeler Condenser and Eng. Co.)

Owing to their great cost as compared with jet-condensers, surface condensers should not be used except where absolutely necessary, i.e., where lack of feed-water for the boiler warrants the extra cost. Of course there are cases, such as at sea, where surface condensers are indispensable.



On land, suitable feed-water can always be obtained at some expense, and that cost capitalized makes it a simple arithmetical problem to determine the extra investment permissible in order to be able to return condensed steam as feed-water to the boiler. Unfortunately there is another point which greatly complicates the matter, and one which makes it impossible to give exact figures, viz., the corrosion and deterioration of the condenser tubes themselves, the exact cause of which is not often understood. With clean, fresh water, free from acid, the tubes of a condenser last indefinitely, but where the cooling-water contains sulphur, as in drainage from coal mines, or sea-water contaminated by sewage, such as harbor water, the deterioration is exceedingly rapid.

A better vacuum may possibly be obtained from a surface condenser where there is plenty of cooling-water easily handled. The better vacuum is due to the fact that the air-pump will have much less air to handle inasmuch as the air carried in suspension by the cooling-water does not have to be extracted as in the case of jet-condensers. Water in open rivers, the ocean, etc., is said to carry in suspension 5% by volume of air. It may be said that except for leakages, which should not exist, the air-pump will have no work to do at all inasmuch as the water will have no opportunity to become aerated. On the other hand, if the cooling-water is limited, these advantages are offset by the fact that a surface condenser cannot heat the cooling-water so near to the temperature of the exhaust steam as can a jet-condenser. (F. Hodgkinson, *El. Jour.*, Aug., 1909.)

A barometric condenser used in connection with a 15,000-k.w. steam-engine-turbine unit at the 59th St. station of the Rapid Transit Co., New York, contains approximately 25,000 sq. ft. of cooling surface arranged in the double two-pass system of water circulation, with a 30-in. centrifugal circulating pump having a maximum capacity of 30,000 gal. per hour. The dry vacuum pump is of the single-stage type, 12- and 29-in.  $\times$  24-in., with Corliss valves on the air cylinder. The condensing plant is capable of maintaining a vacuum within 1.1 in. of the barometer when condensing 150,000 lb. of steam per hour when supplied with circulating water at 70° F. — (H. G. Stott, *Jour. A.S.M.E.*, Mar., 1910.)

**Cooling Towers** are usually made in the shape of large cylinders of sheet steel, filled with narrow boards or lath arranged in geometrical forms, or hollow tile, or wire network, so arranged that while the water, which is sprayed over them at the top, trickles down through the spaces it is met by an ascending air column. The air is furnished either by disk fans at the bottom or is drawn in by natural draught. In the latter case the tower is made very high, say 60 to 100 ft., so as to act like a chimney. When used in connection with steam condensers, the water produced by the condensation of the exhaust steam is sufficient to compensate for the evaporation in the tower, and none need be supplied to the system. There is, on the contrary, a slight overflow, which carries with it the oil from the engine cylinders, and tends to clean the system of oil that would otherwise accumulate in the hot-well.

The cooling of water in a pond, spray, or tower goes on in three ways — first, by radiation, which is practically negligible; second, by conduction or absorption of heat by the air, which may vary from one-fifth to one-third of the entire effect; and, lastly, by evaporation. The latter is the chief effect. Under certain conditions the water in a cooling tower can actually be cooled below the temperature of the atmosphere, as water is cooled by exposing it in porous vessels to the winds of hot and dry climates.

The evaporation of 1 lb. of water absorbs about 1000 heat units. The rapidity of evaporation is determined, first, by the temperature of the water, and, second, by the vapor tension in the air in immediate contact with the water. In ordinary air the vapor present is generally in a condition corresponding to superheated steam, that is, the air is not saturated. If saturated air be brought into contact with colder water, the cooling of the vapor will cause some of it to be precipitated out of the air; on the other hand, if saturated air be brought into contact with warmer water, some of the latter will pass into the form of vapor. This is what occurs in the cooling tower, so that the latter is in a large measure independent of climatic conditions; for even if the air be saturated, the rise in temperature of the atmospheric air from contact with the hot water in the cooling tower will greatly increase the water-carrying capacity of the air, enabling a large amount of heat to be absorbed through the evaporation

of the water. The two things to be sought after in cooling-tower design are, therefore, first, to present a large surface of water to the air, and, second, to provide for bringing constantly into contact with this surface the largest possible volume of new air at the least possible expenditure of energy. (Wheeler Condenser and Engineering Co.)

The great advantage of the cooling tower lies in the fact that large surfaces of water can be presented to the air while the latter is kept in rapid motion.

**Calculation of the Air Supply for a Cooling Tower.**—Let  $T_1$  and  $T_2$  be the temperatures of the water entering and leaving;  $t_1$  temperature of the air supply;  $z$  its relative humidity;  $t_2$ , temperature of the air leaving;  $m_1 m_2$ , pounds of moisture in one pound of saturated air at temperatures  $t_1, t_2$ ;  $e_1, e_2$ , total heat, B.T.U., above  $32^\circ$  F. per pound of water vapor at temperatures  $t_1, t_2$ ;  $A =$  lb. of air supplied per lb. of entering water. All temperatures are in degrees F.

Then, for each 1 lb. of water entering the tower the heat (B.T.U.) carried in is: by the water,  $T_1 - 32$ ; by the air,  $0.2375 A (t_1 - 32) + A m_1 e_1 z$ . The heat carried out is: by the water,  $[1 - (m_2 - m_1 z)] \times (T_2 - 32)$ ; by the air,  $0.2375 A (t_2 - 32) + A (m_2 e_2)$ . Neglecting loss by radiation, the heat carried into the tower equals the heat leaving it. Equating these quantities and solving for  $A$  we have:

$$A = \frac{T_1 - T_2}{0.2375 (t_2 - t_1) + m_2 e_2 - m_1 e_1 z - (m_2 - m_1 z) (T_2 - 32)}$$

From this equation the table on p. 1081 has been calculated.

**Water Evaporated in a Cooling Tower.**—The following table gives the values of  $(m_2 - m_1 z)$  per pound of air in the cooling-tower formula. Multiplying these values by the number of pounds of air per pound of water for the given conditions, will give the amount of water evaporated, or make-up water required with surface condensers, per pound of the inflowing water.

**Pounds Water Evaporated per Pound of Air.**

		$t_1 = 50^\circ$			$70^\circ$			$80^\circ$		
$T_1 = 100^\circ$	$z = 0.5$	0.7	0.9	0.5	0.7	0.9	0.5	0.7	0.9	
$t_2 = \begin{cases} 92 \\ 88 \\ 84 \end{cases}$	.02912	.02761	.02610	.02455	.02120	.01786	.02188	.01748	.01308	
	.02503	.02352	.02201	.02046	.01711	.01377	.01779	.01339	.00899	
	.02141	.01990	.01839	.01684	.01349	.01015	.01417	.00977	.00537	
$T_1 = 110^\circ$	$t_1 = 50^\circ$			$70^\circ$			$90^\circ$			
$t_2 = \begin{cases} 102 \\ 98 \\ 94 \end{cases}$	.04179	.04028	.03877	.03722	.03387	.03053	.03017	.02402	.01785	
	.03626	.03475	.03324	.03169	.02834	.02500	.02464	.01848	.01232	
	.03135	.02984	.02833	.02678	.02343	.02009	.01972	.01357	.00741	
$T_1 = 120^\circ$	$t_1 = 50^\circ$			$70^\circ$			$90^\circ$			
$t_2 = \begin{cases} 112 \\ 108 \\ 104 \end{cases}$	.05905	.05754	.05603	.05448	.05113	.04779	.04743	.04127	.03511	
	.05151	.05000	.04845	.04694	.04359	.04025	.03989	.03373	.02757	
	.04482	.04331	.04180	.04025	.03690	.03356	.03320	.02704	.02088	

**Tests of a Cooling Tower and Condenser** are reported by J. H. Vail in *Trans. A. S. M. E.*, 1898. The tower was of the Barnard type, with two chambers, each 12 ft. 3 in.  $\times$  18 ft.  $\times$  29 ft. 6 in. high, containing galvanized-wire mats. Four fans supplied a strong draught to the two chambers. The rated capacity of each section was to cool the circulating water needed to condense 12,500 lbs. of steam, from  $132^\circ$  to  $80^\circ$  F., when the atmosphere does not exceed  $75^\circ$  F. nor the humidity 85%. The following is a record of some observations.

Date, 1898.	Jan.	Feb.	June	July.	Aug.	Nov.	Aug. 2.	
	31.		20.		26.	4.	Max.	Min.
Temperature atmosphere.	$30^\circ$	$36^\circ$	$78^\circ$	$96^\circ$	$85^\circ$	$59^\circ$	$103^\circ$	$83^\circ$
Temp. condenser discharge	$110^\circ$	$110^\circ$	$120^\circ$	$130^\circ$	$118^\circ$	$129^\circ$	$128^\circ$	$106^\circ$
Temp. water from tower..	$65^\circ$	$84^\circ$	$84^\circ$	$93^\circ$	$88^\circ$	$92^\circ$	$98^\circ$	$91^\circ$
Heat extracted by tower..	$45^\circ$	$26^\circ$	$36^\circ$	$37^\circ$	$30^\circ$	$37^\circ$	$32^\circ$	$21^\circ$
Speed of fans, r.p.m.....	36	0	145	162	150	148	160	140
Vacuum, inches.....	$25\frac{1}{2}$	26	25	$24\frac{1}{2}$	$25\frac{1}{2}$	25	26	26

The quantity of steam condensed or of water circulated is not stated.

**Pounds of Air per Pound of Circulating Water.**

Outflowing air saturated.

$T_1 = 100^\circ$	$t_1 = 50^\circ$			$70^\circ$			$80^\circ$			
	$T_2 \ t_2$	$z = 0.5$	0.7	0.9	0.5	0.7	0.9	0.5	0.7	0.9
70	92	0.732	0.761	0.793	0.956	1.076	1.233	1.147	1.395	1.780
	88	0.842	0.881	0.924	1.152	1.333	1.580	1.442	1.857	2.608
	84	0.984	1.027	1.085	1.415	1.698	2.120	1.879	2.650	4.500
80	92	0.492	0.511	0.532	0.642	0.723	0.828	0.771	0.938	1.196
	88	0.565	0.591	0.620	0.774	0.895	1.061	0.970	1.249	1.752
	84	0.654	0.689	0.728	0.951	1.141	1.423	1.264	1.783	3.025
90	92	0.248	0.257	0.268	0.324	0.364	0.417	0.389	0.472	0.603
	88	0.285	0.298	0.312	0.390	0.451	0.534	0.489	0.632	0.883
	84	0.329	0.347	0.367	0.479	0.575	0.717	0.638	0.899	1.524
$T_1 = 110^\circ$	$t_1 = 50^\circ$			$70^\circ$			$90^\circ$			
70	102	0.702	0.722	0.743	0.844	0.911	0.991	1.139	1.400	1.815
	98	0.799	0.824	0.852	0.988	1.082	1.196	1.419	1.847	2.646
	94	0.912	0.946	0.983	1.168	1.302	1.470	1.822	2.595	4.505
80	102	0.530	0.545	0.561	0.638	0.689	0.749	0.862	1.059	1.376
	98	0.603	0.623	0.644	0.747	0.818	0.904	1.074	1.404	2.001
	94	0.689	0.715	0.742	0.883	0.984	1.111	1.379	1.963	3.405
90	102	0.356	0.366	0.377	0.429	0.463	0.503	0.580	0.712	0.923
	98	0.402	0.418	0.432	0.502	0.549	0.607	0.722	0.944	1.345
	94	0.463	0.480	0.498	0.593	0.661	0.746	0.928	1.321	2.291
$T_1 = 120^\circ$	$t_1 = 50^\circ$			$70^\circ$			$90^\circ$			
70	112	0.640	0.654	0.667	0.730	0.770	0.814	0.890	1.007	1.160
	108	0.725	0.742	0.760	0.843	0.896	0.956	1.063	1.234	1.472
	104	0.823	0.845	0.868	0.977	1.050	1.133	1.287	1.547	1.940
80	112	0.516	0.527	0.538	0.589	0.621	0.656	0.718	0.812	0.936
	108	0.585	0.598	0.613	0.680	0.722	0.771	0.858	0.996	1.187
	104	0.663	0.681	0.699	0.788	0.846	0.914	1.038	1.248	1.564
90	112	0.390	0.398	0.406	0.445	0.469	0.496	0.543	0.613	0.707
	108	0.442	0.452	0.463	0.514	0.546	0.583	0.649	0.753	0.898
	104	0.501	0.515	0.528	0.596	0.640	0.690	0.786	0.944	1.183

**CUBIC FEET IN 1 POUND OF AIR.**

Temp. deg. F.	32	50	60	70	80	90
Cu. ft.	12.387	12.84	13.09	13.34	13.59	13.84

**Weight of Water Vapor Mixed with 1 lb. of Air at Atmospheric Pressure.**

Full Saturation. Values interpolated from table on page 613.

Deg. F.	Mois- ture, lb.	Deg. F.	Mois- ture, lb.	Deg. F.	Mois- ture, lb.	Deg. F.	Mois- ture, lb.	Deg. F.	Mois- ture, lb.
32	0.00374	54	0.00874	76	0.01917	98	0.04002	120	0.08099
34	.00406	56	.00940	78	.02054	100	.04270	122	.08629
36	.00439	58	.01012	80	.02200	102	.04555	124	.09193
38	.00475	60	.01089	82	.02353	104	.04858	126	.09794
40	.00514	62	.01171	84	.02517	106	.05182	128	.10437
42	.00555	64	.01259	86	.02692	108	.05527	130	.11123
44	.00600	66	.01353	88	.02879	110	.05893	132	.11855
46	.00648	68	.01453	90	.03077	112	.06281	134	.12637
48	.00699	70	.01557	92	.03288	114	.06695	136	.13473
50	.00753	72	.01669	94	.03511	116	.07134	138	.14367
52	.00812	74	.01789	96	.03750	118	.07601	140	.15324



but in the two tests on Aug. 2 the H.P. developed was 900 I.H.P. in the first and 400 in the second, the engine being a tandem compound, Corliss type, 20 and 36 × 42 in., 120 r.p.m.

J. R. Bibbins (*Trans. A.S.M.E.*, 1909) gives a large amount of information on the construction and performance of different styles of cooling towers. He suggests a type of combined fan and natural draft tower suited to most efficient running on peak as well as light loads.

**Evaporators and Distillers** are used with marine engines for the purpose of providing fresh water for the boilers or for drinking purposes.

*Weir's Evaporator* consists of a small horizontal boiler, contrived so as to be easily taken to pieces and cleaned. The water in it is evaporated by the steam from the main boilers passing through a set of tubes placed in its bottom. The steam generated in this boiler is admitted to the low-pressure valve-chest, so that there is no loss of energy, and the water condensed in it is returned to the main boilers.

In *Weir's Feed-heater* the feed-water before entering the boiler is heated up very nearly to boiling-point by means of the waste water and steam from the low-pressure valve-chest of a compound engine.

### ROTARY STEAM-ENGINES — STEAM TURBINES.

**Rotary Steam-engines**, other than steam turbines, have been invented by the thousands, but not one has attained a commercial success, as regards economy of steam. For all ordinary uses the possible advantages, such as saving of space, to be gained by a rotary engine are overbalanced by its waste of steam. Rotary engines are in use, however, for special purposes, such as steam fire-engines and steam feeds for sawmills, in which steam economy is not a matter of importance.

**Impulse and Reaction Turbines.**— A steam turbine of the simplest form is a wheel similar to a water wheel, which is moved by a jet of steam impinging at high velocity on its blades. Such a wheel was designed by Branca, an Italian, in 1629. The De Laval steam turbine, which is similar in many respects to a Pelton water wheel, is of this class. It is known as an impulse turbine. In a book written by Hero, of Alexandria, about 150 B.C., there is shown a revolving hollow metal ball, into which steam enters through a trunnion from a boiler beneath, and escapes tangentially from the outer rim through two arms which are bent backwards, so that the steam by its reaction causes the ball to rotate in an opposite direction to that of the escaping jets. This wheel is the prototype of a reaction turbine. In most modern steam turbines both the impulse and reaction principles are used, jets of steam striking blades or buckets inserted in the rim of a wheel, so as to give it a forward impulse, and escaping from it in a reverse direction so as to react upon it. The name impulse wheel, however, is now generally given to wheels like the De Laval, in which the pressure on the two sides of a wheel containing the blades is the same, and the name reaction wheel to one in which the steam decreases in pressure in passing through the blades. The Parsons turbine is of this class.

**The De Laval Turbine.**— The distinguishing features of this turbine are the diverging nozzles, in which the steam expands down to the atmospheric pressure in non-condensing, and to the vacuum pressure in condensing wheels; a single forged steel disk carrying the blades on its periphery; a slender, flexible shaft on which the wheel is mounted and which rotates about its center of gravity; and a set of reducing gears, usually 10 to 1 reduction, to change the very high speed of the turbine to a moderate speed for driving machinery. Following are the sizes and speeds of some De Laval turbines:

Horse-power.....	5	30	100	300
Revolutions per minute.....	30,000	20,000	13,000	10,000
Diam. to center of blades, ins.	3.94	8.86	19.68	29.92

The number and size of nozzles vary with the size of the turbine. The nozzles are provided with valves, so that for light loads some of them may be closed, and a relatively high efficiency is obtained at light loads. The taper of the nozzles differs for condensing and non-condensing turbines. Some turbines are provided with two sets of nozzles, one for condensing and the other for non-condensing operation.

The disk of the De Laval turbine is not mounted midway between the shaft bearings, but considerably nearer to the spherical bearing

at the governor end. At low speeds the shaft bends, but as the speed increases the gyroscopic action of the disk causes it to rotate in a plane at right angles to an axis through the center of gravity of the shaft and disk. The speed just below that at which this takes place, and at which the vibration of the shaft is greatest, is called the critical speed. It is about  $\frac{1}{5}$  to  $\frac{1}{8}$  of the normal speed of the turbine.

The diameter of the shaft of a De Laval 100-H.P. turbine is 1 in., and that of a 300-H.P. about  $\frac{15}{16}$  in. The teeth of the pinions of the reducing gear are cut in an enlarged section of the shaft. The pitch of the gears is very small, 0.15 in. in the smallest and 0.26 in. in the largest sizes. The shaft is said to be made of 0.60 to 0.80 C steel and the gears of 0.20 C steel.

**The Zolley or Rateau Turbine.**—The Zolley or Rateau turbines are developments of the De Laval and consist of a number of De Laval elements in series, each succeeding element utilizing the exhaust steam from the preceding. The steam is partly expanded in the first row of nozzles, strikes the first row of buckets and leaves them with practically zero velocity. It is then further expanded through the second row of nozzles, strikes a second row of moving buckets and again leaves them with zero velocity. This process is repeated until the steam is completely expanded.

**The Parsons Turbine.**—In the Parsons, or reaction type of turbine, there are a large number of rows of blades, mounted on a rotor or revolving drum. Between each pair of rows there is a row of stationary blades attached to the casing, which take the place of nozzles. A set of stationary blades and the following set of moving blades constitute what is known as a stage. The steam expands and loses pressure in both sets. The speed of rotation, the peripheral speed of the blades and the velocity of the steam through the blades are very much lower than in the De Laval turbine. The rotor, or drum, on which the moving blades are carried, is usually made in three sections of different diameters, the smallest at the high-pressure end where steam is admitted, and the largest at the exhaust end. In each section the radial length of the blades and also their width increase from one end to the other, to correspond with the increased volume of steam. The Parsons turbine is built in the United States by the Westinghouse Machine Co. and by the Allis-Chalmers Co.

**The Westinghouse Double-flow Turbine.**—For sizes above 5000 K.W. a turbine is built in which the impulse and reaction types are combined. It has a set of non-expanding nozzles, an impulse wheel with two velocity stages (that is two wheels with a set of stationary non-expanding blades between), one intermediate section and two low-pressure sections with Parsons blading. After steam has passed through the impulse wheel and the intermediate section it is divided into two parts, one going to the right and the other to the left hand low-pressure section. There is an exhaust pipe at each end. In this turbine, the end thrust, which has to be balanced in reaction turbines of the usual type, is almost entirely avoided. Other advantages are the reduction in size and weight, due to higher permissible speed; blades and casing are not exposed to high temperatures; reduction of size of exhaust pipes and of length of shaft; avoidance of large balance pistons.

**The Curtis Turbine,** made by the General Electric Company, is an impulse wheel of several stages. Steam is expanded in nozzles and enters a set of three or more blades, at least one of which is stationary. The blades are all non-expanding, and the pressure is practically the same on both sides of any row of blades. In smaller sizes of turbines, only one set of stationary and movable blades is used, but in large sizes there are from two to five sets, each forming a pressure stage, separated by diaphragms containing additional sets of nozzles. The smaller sizes have horizontal shafts, but the larger ones have vertical shafts supported on a step bearing supplied with oil or water under a pressure sufficient to support the whole weight of the shaft and its attached rotating disks. Curtis turbines are made in sizes from 15 K.W. at 3600 to 4000 revs. per minute up to 9000 K.W. at 750 revs. per minute.

**The Spiro Turbine** consists of two "herring-bone" helical gear wheels meshed together and revolving in a closely fitting casing. The steam enters through two non-expanding nozzles at mid-length of the gears, expands into the spaces between adjacent gear teeth and escapes at

the outer ends of the teeth when they pass the line of contact between the two rotors. The turbine is made in small sizes, under 100 H.P., and is used non-condensing. Its merits are compactness and simplicity, but it is not economical of steam.

**Mechanical Theory of the Steam Turbine.**—In the impulse turbine of the De Laval type, with a single disk containing blades at its rim, steam at high pressure enters the smaller end or throat of a tapering nozzle, and, as it passes through the nozzle, is expanded adiabatically down to the pressure in the casing of the turbine, that is to the pressure of the atmosphere, in a non-condensing turbine, or to the pressure of the vacuum, if the turbine is connected to a condenser. The steam thus expanded has its volume and its velocity enormously increased, its pressure energy being converted into energy of velocity. It then strikes tangentially the concave surfaces of the curved blades, and thus drives the wheel forward. In passing through the blades it has its direction reversed, and the reaction of the escaping jet also helps to drive the wheel forward. If it were possible for the direction of the jet to be completely reversed, or through an arc of  $180^\circ$ , and the velocity of the blade in the direction of the entering jet was one-half the velocity of the jet, then all the kinetic energy due to the velocity of the jet would be converted into work on the blade, and the velocity of the jet with reference to the earth would be zero. This complete reversal, however, is impossible, since room has to be allowed between the blades for the passage of the steam, and the blades, therefore, are curved through an arc considerably less than  $180^\circ$ , and the jet on leaving the wheel still has some kinetic energy, which is lost. The velocity of the entering steam jet also is so great that it is not practicable to give the wheel rim a velocity equal to one-half that of the jet, since that would be beyond a safe speed. The speed of the wheel being less than half that of the entering jet, also causes the jet to leave the wheel with some of its energy unutilized. The mechanical efficiency of the wheel, neglecting radiation, friction, and other internal losses, is expressed by the fraction  $(E_1 - E_2) \div E_1$ , in which  $E_1$  is the kinetic energy of the steam jet impinging on the wheel and  $E_2$  that of the steam as it leaves the blades.

In multiple-stage impulse turbines, the high velocity of the wheel is reduced by causing the steam to pass through two or more rows of blades, which rows are separated by a row of stationary curved blades which direct the steam from the outlet of one row to the inlet of the next. The passages through all the blades, both movable and secondary, are parallel, or non-expanding, so that the steam does not change its pressure in passing through them. The wheel with two rows of movable blades running at half the velocity of a single-stage turbine, or one with three rows at one-third the velocity, causes the same total reduction in velocity as the single-stage wheel; and a greater reduction in the velocity of the wheel can be obtained by increasing the number of rows. It is, therefore, possible by having a sufficient number of rows of blades, or velocity stages, to run a wheel at comparatively slow speed and yet have the steam escape from the last set of blades at a lower absolute velocity than is possible with a single-stage turbine. In the reaction turbine the reduction of the pressure and its conversion into kinetic energy, or energy of velocity, takes place in the blades, which are made of such shape as to allow the steam to expand while passing through them. The stationary blades also allow of expansion in volume, thus taking the place of nozzles.

In all turbines, whether of the impulse, reaction, or combination type, the object is to take in steam at high pressure and to discharge it into the atmosphere, or into the condenser, at the lowest pressure and largest volume possible, and with the lowest possible absolute velocity, or velocity with reference to the earth, consistent with getting the steam away from the wheel, and to do this with the least loss of energy in the wheel due to friction of the steam through the passages, to shock due to incorrect shape, or position of the blades, to windage of frictional resistance of the steam in contact with the rotating wheel, or other causes. The minimizing of these several losses is a problem of extreme difficulty which is being solved by costly experiments.

**Heat Theory of the Steam Turbine.**—The steam turbine may also be considered as a heat engine, the object of which is to take a pound of



steam containing a certain quantity of heat,  $H_1$ , transform as great a part of this heat as possible into work, and discharge the remaining part,  $H_2$ , into the condenser. The thermal efficiency of the operation is  $(H_1 - H_2) \div H_1$ , and the theoretical limit of this efficiency is  $(T_1 - T_2) \div T_2$ , in which  $T_1$  is the initial and  $T_2$  the final absolute temperature.

Referring to temperature entropy diagram, Fig. 176, the total heat above  $32^\circ$  F. of 1 lb. of steam at the temperature  $T_1$  is represented by the area  $OACDG$  and its entropy is  $\phi_1$ . Expanding adiabatically to  $T_2$  part of its heat energy is converted into work, represented by the area  $BCDF$ , while  $OABFG$  represents the heat discharged into the condenser. The total heat of 1 lb. of dry saturated steam at  $T_2$  is greater than this by the area  $EFGH$ , the fraction  $FE \div BE$  representing moisture in the 1 lb. of wet steam discharged. If  $H_1 =$  heat units in 1 lb. of dry steam at the state-point  $D$ , and  $H_2 =$  heat units in 1 lb. of dry steam at the state-point  $E$ , at the temperature  $T_2$ , then the energy converted into work  $=BCDF = H_1 - H_2 + (\phi_2 - \phi_1) T_2$ . This quantity is called the available energy  $E_a$ , of 1 lb. of steam between the temperatures  $T_1$  and  $T_2$ .

If the steam is initially wet, as represented by the state-point  $d$  and entropy  $\phi_x$ , then the work done in adiabatic expansion is  $BCdfB$ , which is equal to  $E_a = H_1 - H_2 + (\phi_2 - \phi_1) T_2 - (\phi_1 - \phi_x)(T_1 - T_2)$ . The quantity  $\phi_1 - \phi_x = (L/T_1)(1 - x)$ , in which  $L =$  latent heat of evaporation at the temperature  $T_1$ , and  $x =$  the moisture in 1 lb. of steam. The values of  $H_1, H_2, \phi_1, \phi_2$ , etc., for different temperatures, may be taken from steam tables or diagrams.

If the steam is initially superheated to the temperature  $T_s$ , as represented by the state-point  $j$ , the entropy being  $\phi_3$ , then the total heat at  $j$  is  $H_1 + C(T_s - T_1)$ , in which  $C$  is the mean specific heat of superheated steam between  $T_1$  and  $T_s$ . The increase of entropy above  $\phi_1$  is  $\phi_3 - \phi_1 = C \log_e(T_s/T_1)$ . The energy converted into work is  $E_a = H_1 - H_2 + (\phi_2 - \phi_1) T_2 + [1/2(T_s + T_1) - T_2](\phi_3 - \phi_1)$ .

**Velocity of Steam in Nozzles.**—Having obtained the total available energy in steam expanding adiabatically between two temperatures, as shown above, the maximum possible flow into a vacuum is obtained from the common formula, Energy, in foot-pounds,  $= 1/2 W/g \times V^2$ , in which  $W$  is the weight (in this case 1 lb.),  $V$  is the velocity in feet per second, and  $g = 32.2$ . As the energy  $E_a$  is in heat units, it is multiplied by 778 to convert it into foot-pounds, and we have

$$V = \sqrt{778 \times 2g E_a} = 223.8 \sqrt{E_a}$$

This is the theoretically maximum possible velocity. It cannot be obtained in a short nozzle or orifice, but is approximated in the long expanding nozzles used in turbines. In the throat or narrow section of an orifice, the velocity and the weight of steam flowing per second may be found by Napier's or Rateau's formula, see page 876, or from Grashof's formula as given by Moyer,  $F = A_o P_1^{0.97} \div 60$ , or  $A_o = 60 F \div P_1^{0.97}$ , in which  $A_o$  is the area of the smallest section of the nozzle, sq. in.,  $F$  is the flow of steam (initially dry saturated) in lbs. per sec., and  $P$  is the absolute pressure, lbs. per sq. in. This formula is applicable in all cases where the final pressure  $P_2$  does not exceed 58% of the initial pressure. For wet steam the formula becomes  $F = A_o P_1^{0.97} \div 60 \sqrt{x}$ ,  $A_o = 60 F \sqrt{x} \div P_1^{0.97}$ , in which  $x$  is the dryness quality of the inflowing steam,  $1 - x$  being the moisture.

For superheated steam  $F = A_o P_1^{0.97} (1 + 0.00065 D) \div 60$ ;  $A_o = 60 F \div P_1^{0.97} (1 + 0.00065 D)$ ,  $D$  being the superheat in degrees F.

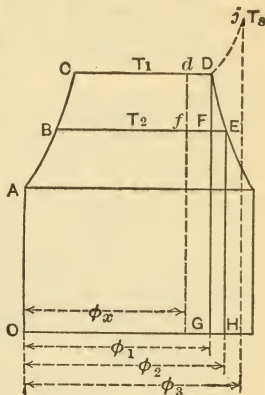

FIG. 176.

When the final pressure  $P_2$  is greater than  $0.58 P_1$ , a coefficient is to be applied to  $F$  in the above formulæ, the value of which is most conveniently taken from a curve given by Rateau. The values of this coefficient,  $c$ , for different ratios of  $P_1/P_2$ , are approximately as follows:

$P_2 \div P_1 =$	0.58	0.60	0.62	0.64	0.66	0.68	0.70	0.72	0.74	0.76	0.78
$c =$	1.	0.995	0.985	0.975	0.965	0.955	0.945	0.93	0.91	0.88	0.85
$P_2 \div P_1 =$	0.80	0.82	0.84	0.86	0.88	0.90	0.92	0.94	0.96	0.98	1.00
$c =$	0.82	0.79	0.76	0.72	0.675	0.625	0.57	0.51	0.42	0.30	0.00

The quality of steam after adiabatic expansion,  $x_2$ , is found from the formula

$$x_2 = (x_1 L_1 / T_1 + \theta_1 - \theta_2) T_2 / L_2, \quad (8)$$

in which  $\theta_1$  and  $\theta_2$  are the entropies of the liquid,  $L_1$  and  $L_2$  the latent heats of evaporation, and  $x_1$  and  $x_2$  the dryness quality, at the initial and final conditions respectively. Curves of steam quality are plotted in an entropy-total heat chart given in Moyer's "Steam Turbines" and also in Marks and Davis's "Steam Tables and Diagrams."

The area of the smallest section or throat of the nozzle being found, the area of any section beyond the throat is inversely proportional to the velocity and directly proportional to the specific volume and to the dryness, or  $A_1/A_0 = V_0/V_1 \times v_1/v_0 \times x_1/x_0$ , in which  $A$  is in the area in sq. ins.,  $V$  the velocity in ft. per sec.,  $v$  the volume of 1 lb. of steam in cu. ft., and  $x$  the dryness fraction, the subscript 0 referring to the smallest section and the subscript 1 to any other section. The ratio  $A_1/A_0$  for the largest cross section of a properly designed nozzle depends upon the ratio of the initial to the final pressure. Moyer gives it as  $A_1/A_0 = 0.172 P_1/P_2 + 0.70$ , and for  $P_1/P_2$  greater than 25,  $A_1/A_0 = 0.175 (P_1/P_2)^{0.94} + 0.70$ .

In practice expanding nozzles are usually made so that an axial section shows the inner walls in straight lines. The transverse section is usually either a circle or a square with rounded corners. The divergence of the walls is about 6 degrees from the axis for the non-condensing and as much as 12 degrees for condensing turbines for low vacuums. Moyer gives an empirical formula for the length between the throat and the mouth,  $L = \sqrt{15 A_0}$  inches. The De Laval turbine uses a much longer nozzle for mechanical reasons. The entrance to the nozzle above the throat should be well rounded. The efficiency of a well-made nozzle with smooth surfaces as measured by the velocity is about 96 to 97%, corresponding to an energy efficiency of 92 to 94%.

**Speed of the Blades.**—If  $V_b$  = peripheral velocity of the blade,  $V_1$  = absolute velocity of the steam entering the blades and  $\alpha$  the nozzle angle, or angle of the nozzle to the plane of the wheel, then (in impulse turbines with equal entrance and exit angles of the blade with the plane of the wheel) for maximum theoretical efficiency of the blade,  $V_b = 1/2 V_1 \cos \alpha$ . The nozzle angle is usually about  $20^\circ$ ,  $\cos \alpha = 0.940$ , and the efficiency of a single row of blades is  $(0.94 - V_b/V_1) 4 V_b/V_1$ .

For  $V_1 = 3000$  ft. per sec., the efficiency for different blade speeds is about as follows:

$V_b =$	200	400	600	800	1000	1200	1400	1600	1800	2000
Efficiency, %	23	44	60	72	81	87	89	87	80	71

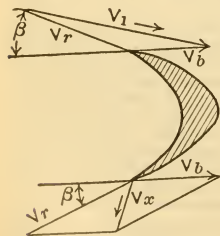

FIG. 177.

The highest efficiency is obtained when  $V_b = \text{about } 1/2 V_2$ . It is difficult, for mechanical reasons, to use speeds much greater than 500 ft. per sec., therefore the highest efficiencies are often sacrificed in commercial machines. The blade speeds used in practice vary from 500 to 1200 ft. per sec. For an impulse wheel with more than one row of moving blades in a single pressure stage, efficiency

$$= \frac{4 N V_b}{V_1} \left( \cos \alpha - \frac{N V_b}{V_1} \right).$$

Referring to Fig. 177, if  $V_1$  is the absolute direction and velocity of the entering jet,  $V_b$  the direction and velocity of the blade, the resultant,  $V_r$ , is the velocity and direction of the jet relatively to the blade, and the edge of the blade is made tangent to this direction. Also

$V_x$ , the resultant of  $V_b$  and  $V_r$  at the other edge of the blade, is the absolute velocity and direction of the steam escaping from the wheel. If  $\beta$  is the angle between  $V_r$  and  $V_b$ , the maximum energy is abstracted from the steam when the angle between  $V_x$  and  $V_b = 90 - 1/2 \beta$ , and the efficiency is  $\cos \beta \div \cos^2 1/2 \beta$ .

For details of design of blades, and of turbines in general, see Moyer, Foster, Thomas, Stodola and other works on Steam Turbines, also Peabody's "Thermodynamics." Calculations of stages, nozzles, etc., are much facilitated by the use of Peabody's "Steam Tables" and Marks and Davis's "Steam Tables and Diagrams."

### Comparison of Commercial Impulse and Reaction Turbines. (Moyer.)

#### IMPULSE.

1. Few stages.
2. Expansion in nozzles.
3. Large drop in pressure in a stage.
4. Initial steam velocities 1000 to 4000 ft. per sec.
5. Blade velocities 400 to 1200 ft. per sec.
6. Best efficiency when the blade velocity is nearly half the initial velocity of steam.

#### REACTION.

1. Many stages.
2. No nozzles.
3. Small drop in pressure in a stage.
4. All steam velocities low, 300 to 600 ft. per sec.
5. Blade velocities 150 to 400 ft. per sec.
6. Best efficiency when the blade velocity is nearly equal to the highest velocity of the steam.

**Loss due to Windage** (or friction of a turbine wheel rotating in steam). — Moyer gives for the friction of a plain disk without blades,  $F_w$ , and of one row of blades without the disk,  $F_b$ , in horse-power:

$$F_w = 0.08 d^2 (u/100)^{2.8} w \div (1 + 0.00065 D)^2,$$

$$F_b = 0.3 d l^{1.5} (u/100)^{2.8} w \div (1 + 0.00065 D)^2,$$

in which  $d$  = diam. of disk to inner edge of blade, in feet;  $u$  = peripheral velocity of disk, in ft. per sec.;  $w$  = density of dry saturated steam at the pressure surrounding the disk, in lbs. per cu. ft., and  $D$  = superheat in degrees F. The sum of  $F_w$  and  $F_b$  is the friction of the disk and blades. For moist steam the term  $1 + 0.00065 D$  is to be omitted, and the expression multiplied by a coefficient  $c$ , whose value is approximately as follows:

Per cent moisture in steam	2	4	6	8	10	12	16	20	24
Coefficient $c$ ...	1.01	1.05	1.10	1.16	1.25	1.37	1.65	2.00	2.44

At high rotative speeds the rotation loss of a non-condensing turbine with wheels revolving in steam at atmospheric pressure is quite large, and in small turbines it may be as much as 20% of the total output. The loss decreases rapidly with increasing vacuum. In a turbine with more than one stage part of the friction loss of rotation is converted into heat which in the next stage is converted into kinetic energy, thus partly compensating for the loss.

**Efficiency of the Machine.** — The maximum possible thermodynamic efficiency of a steam turbine, as of any other steam engine, is expressed by the ratio which the available energy between two temperatures bears to the total heat, measured above absolute zero, of the steam at the higher temperature. In the temperature-entropy diagram Fig. 176 it is represented by the ratio of the area  $BCDF$  to  $OACDG$ . Of this available energy, from 50 to 75 and possibly 80 per cent is obtainable at the shaft of turbines of different sizes and designs. As with steam engines, the highest mechanical and thermal efficiencies are reached only with large sizes and the most expensive designs. The several losses which tend to reduce the efficiency of turbines below the theoretical maximum are: 1, residual velocity, or the kinetic energy due to the velocity of the steam escaping from the turbine; 2, friction and imperfect expansion in the nozzles; 3, windage, or friction due to rotation of the wheel in steam; 4, friction of the steam traveling through the blades; 5, shocks, impacts, eddies, etc., due to imperfect shape or roughness of blades; 6, leakage around the ends of the blades or through clearance spaces; 7, shaft friction; 8, radiation. The sum of all these losses amounts to about 25% of the available energy in the largest and best design and to 50% or more in small sizes or poor designs.



**Steam Consumption of Turbines.** — The steam consumption of any steam turbine is so greatly influenced by the conditions of pressure, moisture or superheat, and vacuum, that it is necessary to know the effect of these conditions on any turbines whose performances are to be compared with each other or with a given standard. Manufacturers usually furnish with their guarantees of performance under standard conditions of pressure, superheat and vacuum, a statement or set of curves showing the amount that the steam consumption per K.W.-hour will be increased or diminished by stated variations from these standard conditions. When a test of steam consumption is made under any conditions varying from the standard, the results should be corrected in order to compare them with other tests. Moyer gives the following example of applying corrections to a pair of tests made in 1907, to reduce them both to a steam pressure of 179 lbs. gauge, 28.5 ins. vacuum, and 100° F. superheat.

	7500-K.W. Westing- house- Parsons.	Correc- tions, per cent.	9000-K.W. Curtis.	Correc- tions, per cent.
Average steam pressure.....	177.5	-0.15	179	0
Average vacuum, ins., referred to 30-in. barometer.....	27.3	-3.36	29.55	+12.39
Average superheat, deg. F.....	95.7	-0.29	116	+1.28
Average load on generator, K.W.	9830.5	.....	8070	.....
Steam cons., lbs. per K.W.-hr..	15.15	.....	13.0	.....
Net correction, per cent. ....	.....	-3.80	.....	+13.67
Corr. st. cons., lbs. per K.W.-hr.	14.57	.....	14.77	.....

For the 7500-K.W. turbine, the following corrections given by the manufacturer were used: pressure, 0.1% for each pound; vacuum, 2.8% for each inch; superheat, 7% for each 100° F. For the 9000-K.W. turbine, the following corrections were used: superheat, 8% for 100° F.; vacuum, 8% for each inch.

The results as corrected show that the two turbines would give practically the same economy if tested under uniform conditions. The results are equivalent respectively to 9.58 and 9.72 lbs. per I.H.P.-hour, assuming 97% generator efficiency and 91% mechanical efficiency of a steam-engine.

The proper correction for moisture in a steam turbine test is stated to be a little more than twice the percentage of moisture. There is a large increase in the disk and blade rotation losses when wet steam is used.

**Effect of Vacuum on Steam Turbines.**—M. R. Bump (*Power*, June 15, 1909) gives the following as the steam consumption per K.W. hour of a 1000 K.W. turbine at full rated load, 175 lb. gage pressure, 100° superheat:

Vacuum, in. . . . .	29	28	27	26	25	24	23	22	21
Steam per K.W. hr. lb. . . . .	15.35	16.55	17.50	18.55	19.35	20.00	20.6	21.1	21.6

The gain in economy per inch of vacuum at different vacuums is given as follows in *Mech. Engr.*, Feb. 24, 1906.

Inches of Vacuum.	28	27	26	25
Curtis, per cent gain per inch of vacuum..	5.1	4.8	4.6	4.2
Parsons, per cent gain per inch of vacuum	5.0	4.0	3.5	3.0
Westinghouse-Parsons, per cent gain per inch of vacuum. ....	3.14	3.05	2.95	2.87
Theoretical per cent gain per inch of vac..	5.2	4.4	3.7	3.0

**Tests of Turbines.**—The following results of tests of turbines are selected from a series of tables in Moyer's "Steam Turbines."

Rated K.W.	Output K.W.	Gauge Press.	Super- heat, deg. F.	Vacuum, ins.	Lbs. per K.W.- hour.	Rated K.W.	Output B.H.P.	Gauge Press.	Super- heat, deg. F.	Vacuum, ins.	Lbs. per B.H.P.- hour.
2000 C.	555	155	204	28.5	18.09	300 W.-P.	233	145	4.1	28.0	15.99
	1067	170	120	28.4	16.31		461	145	4.8	28.0	13.99
	2024	166	207	28.5	15.02		688	140	7.0	27.2	15.73
9000 C.	5374	182	133	29.4	13.15	500 W.-P.	383	153	2	28.2	14.15
	8070	179	116	29.4	13.00		756	149	1	27.8	13.28
	10186	176	147	29.5	12.90		1122	149	5	26.5	14.32
	13900	198	140	29.3	13.60		386	148	3	0.8	24.94
1500 P.	530	145	110	28.9	21.58	1000 W.-P.	767	147	3	0.8	22.10
	1071	131	124	28.3	18.24		1144	126	11	0.8	24.36
300 P.	1585	128	125	27.5	17.60	3000 W.-P.	752	151	0	27.5	14.77
	303	158	0	26.6	23.15		1503	147	0	27.0	13.61
1000 R.	297	161	0	0	34.20	300 D	2253	145	0	25.2	15.29
	194	171	47	27.7	31.97		2295	152	102	26.2	12.36
	425	144	21	27.6	24.91		4410	144	87	26.2	11.85
	871	166	11	23.6	24.61		196	198	16	27.4	15.62
	1024	164	10	25.0	21.98		298	197	64	27.4	14.35
							352	199	84	27.2	13.94

C., Curtis; P., Parsons; W.-P., Westinghouse-Parsons; R., Rateau; D., De Laval. Note that the figures of steam consumption in the first half of the table are in lbs. per K.W.-hour; in second half, in lbs. per Brake H.P.-hour.

A test of a Westinghouse double-flow turbine at the Williamsburg power station, Brooklyn N. Y., gave the following results (*Eng. News*, Dec. 30, 1909): Speed, 750 r.p.m.; Steam pressure at throttle, 203.4 lbs.; Superheat, 80.1° F.; Vacuum, 28.6 ins.; Load, 13,384 K.W.; Steam per K.W.-hour, 14.4 lbs.; Efficiency of generator, 98%; Windage, 2.0%; Equivalent B. H. P., 18,620; Steam per B. H. P.-hour, 10.3 lb.

#### Efficiency of the Rankine Cycle, and the Rankine Cycle Ratio.—

An ideal engine operating on the Rankine cycle expands the steam adiabatically to the condenser pressure and the exhaust steam heats the feed water to the condenser temperature. It has no clearance nor loss by leakage or radiation. The efficiency of the Rankine cycle is the quotient of the number of heat-units converted into work by the ideal engine per lb. of steam divided by the difference between the total heat per lb. of the entering steam and the total heat of 1 lb. of feed-water at the condenser temperature.

The Rankine Cycle Ratio is the ratio between the thermal efficiency of an actual engine or turbine and the efficiency of an ideal engine operating on the Rankine cycle between the same temperature and pressure limits as those of the actual engine.

The available energy of 1 lb. of steam supplied = heat utilized per lb. in an ideal engine operating on the Rankine cycle =  $U = H_s - H_2 + T_2(N_2 - N_s)$  in which

$H_s$  = heat-units per lb. of the entering steam, whether saturated or superheated.

$H_2$  = heat units per lb. of the exhaust steam.

$T_2$  = absolute temperature of the exhaust.

$N_s$  and  $N_2$  = respectively the entropy of the entering and of the exhaust steam.

If the exhaust steam is superheated (as it may be in the case of the high-pressure cylinder of a triple expansion engine using highly superheated steam)  $U = H_s - H_2 - T_2(N_s - N_2)$ . (These formulæ may be derived from a study of the entropy temperature diagram, page 1085.)

EXAMPLE.—A steam turbine operating with 225 lb. absolute pressure, 150° superheat. and 28.5 in. vacuum uses 10 lb. of steam per

brake horse-power hour. Required the available energy per lb. steam, the Rankine cycle efficiency and the Rankine cycle ratio.

$H_s = 1285.9$ ;  $H_2 = 1099.2$ ;  $T_2 = 549.6$ ;  $h =$  heat units per lb. of feed-water at the temperature  $T_2 = 58$ .  $W =$  lb. steam per H.P.-hour = 10.  $A =$  heat equivalent of one H.P.-hour =  $1,980,000 \div 777.54 = 2546.5$  B.T.U.;  $N_s = 1.6296$ ;  $N_2 = 2.0058$   $W(H_s - h) =$  total heat supply per H.P.-hour =  $10 \times (1285.9 - 58) = 12,279$  B.T.U. Thermal efficiency  $E = 2546.5 \div W(H - h) = 20.74\%$ . Available energy per lb.,  $U = 1285.9 - 1099.2 + 549.6 (2.0058 - 1.6296) = 393.5$  B.T.U. Rankine cycle efficiency  $E_R = U \div (H_s - h) = 393.5 \div 1227.9 = 32.04\%$ . Rankine cycle ratio  $R = E \div E_R = 20.74 \div 32 = 64.7\%$ .

**Factors for Reduction to Equivalent Rankine Efficiency.**—When engines are tested with different pressures, superheat and vacuum, it is often desirable to reduce the results to a common standard of assumed conditions. The conditions stated in the above example correspond with good modern practice and they probably furnish as good a standard for comparison as any other. The Rankine cycle efficiency  $E_R$ , for this set of conditions is  $32.04\%$ ; the thermal efficiency, for  $W = 10$  lb. is  $20.74\%$ ; and the ratio  $E \div E_R$  is  $64.7\%$ . For another set of conditions, pressure 150 lb., vacuum 27 in., and dry saturated steam  $E_R$  is  $27.0$ . The quotient  $32.04 \div 27.0 = 1.187$ , may be used as a factor to reduce the Rankine efficiency, the Rankine cycle ratio, and the steam consumption per H.P.-hour to the equivalent for standard conditions; thus, equivalent  $E = 27 \times 1.187 = 32.04$ , equivalent  $R$  (assuming  $W = 11.87$  and  $E = 17.48\%$ ) =  $17.48 \times 1.187 = 20.74$ , and equivalent  $W = 11.87 \div 1.187 = 10$  lb., provided the percentage losses due to friction, radiation and leakage are the same for the two conditions. The factor is used as a multiplier to obtain the equivalent thermal efficiency and Rankine cycle ratio, and as a divisor to obtain the equivalent steam consumption. The factor may be found also

from the equation  $F = \frac{32.04 (H_s - h)}{U}$ , in which  $H_s$ ,  $h$ , and  $U$  are the values for the given set of conditions. The factors computed by this formula and the efficiency of the Rankine cycle for different conditions are given in the table at the top of p. 1091.

**Effect of Increase in Pressure, Vacuum and Superheat on Efficiency.**—Selecting from the table on p. 1091 the figures for Rankine cycle efficiency given in the table below and comparing them by taking differences between consecutive figures in both the horizontal and the vertical rows, we find that the increase of efficiency due to increasing either the pressure, the superheat or the vacuum cannot be expressed as a constant percentage, but that it varies with variations in each condition.

EFFECT OF VARYING CONDITIONS ON RANKINE CYCLE EFFICIENCY.

Pressure, Absolute.	Vacuum, In.	Superheat.							
		0°	Diff.		150°	Diff.		300°	Diff.
150	27....	27.0		0.5	27.5	1.5	1.1	28.6	
	28....	28.4	1.4	0.6	29.0	2.4	1.0	30.0	1.4
	29....	30.8	2.4	0.6	31.4		1.0	32.4	2.4
200	27....	28.5		0.6 (1.5)	29.1	1.4	1.0 (1.6)	30.1	(1.5)
	28....	29.9	1.4	0.6 (1.5)	30.5	2.3	1.0 (1.5)	31.5	1.4 (1.5)
	29....	32.2	2.3	0.6 (1.4)	32.8		1.0 (1.4)	33.8	2.3 (1.4)
250	27....	29.7		0.6 (1.2)	30.3	1.3	0.9 (1.2)	31.2	(1.1)
	28....	31.0	1.3	0.6 (1.1)	31.6	2.3	1.0 (1.1)	32.6	1.4 (1.1)
	29....	33.2	2.2	0.6 (1.0)	33.9		0.9 (1.1)	34.2	2.8 (1.1)

The figures in parentheses show the increase in efficiency due to



**Efficiency of Rankine Cycle,  $E_R$  (per cent) and Factor  $F$  for Reduction to Standard Conditions,**

(225 Lb. Absolute Pressure, 150° Superheat, 28.5 In. Vacuum and Rankine Cycle efficiency of 32 per cent being taken as standard.)

Absolut. Pressure, Lb. per Sq. In.	Vacuum In. Mercury.	Superheat, Degrees Fahrenheit.							
		0	50	100	150	200	250	300	
150	27	$E_R$	27.0	27.1	27.3	27.5	27.8	28.2	28.6
		$F$	1.187	1.182	1.174	1.163	1.150	1.136	1.122
	28	$E_R$	28.4	28.5	28.7	29.0	29.3	29.6	30.0
		$F$	1.127	1.122	1.115	1.105	1.094	1.081	1.068
	28.5	$E_R$	29.4	29.6	29.8	30.0	30.3	30.6	31.0
		$F$	1.088	1.083	1.076	1.067	1.057	1.046	1.033
29	$E_R$	30.8	31.0	31.1	31.4	31.7	32.0	32.4	
	$F$	1.040	1.035	1.028	1.020	1.011	1.001	0.989	
200	27	$E_R$	28.5	28.6	28.8	29.1	29.4	29.7	30.1
		$F$	1.124	1.119	1.111	1.100	1.090	1.078	1.064
	28	$E_R$	29.9	30.0	30.2	30.5	30.8	31.1	31.5
		$F$	1.072	1.067	1.060	1.051	1.041	1.030	1.018
	28.5	$E_R$	30.9	31.0	31.2	31.5	31.8	32.1	32.4
		$F$	1.038	1.033	1.026	1.018	1.009	0.998	0.988
29	$E_R$	32.2	32.3	32.6	32.8	33.1	33.4	33.8	
	$F$	0.995	0.990	0.984	0.977	0.968	0.959	0.949	
225	27	$E_R$	29.1	29.2	29.5	29.7	30.0	30.3	30.7
		$F$	1.101	1.096	1.087	1.078	1.068	1.056	1.044
	28	$E_R$	30.5	30.6	30.8	31.1	31.3	31.7	32.0
		$F$	1.052	1.047	1.040	1.031	1.022	1.011	1.000
	28.5	$E_R$	31.4	31.6	31.8	32.0	32.3	32.6	33.0
		$F$	1.019	1.014	1.008	1.000	0.991	0.981	0.971
29	$E_R$	32.7	32.9	33.1	33.4	33.6	34.0	34.3	
	$F$	0.978	0.973	0.967	0.960	0.952	0.943	0.934	
250	27	$E_R$	29.7	29.8	30.0	30.3	30.5	30.9	31.2
		$F$	1.079	1.075	1.068	1.059	1.049	1.038	1.026
	28	$E_R$	31.0	31.1	31.3	31.6	31.9	32.2	32.6
		$F$	1.033	1.029	1.022	1.014	1.005	0.995	0.984
	28.5	$E_R$	32.0	32.1	32.3	32.6	32.8	33.2	33.5
		$F$	1.002	0.998	0.992	0.984	0.975	0.966	0.956
29	$E_R$	33.2	33.4	33.6	33.9	34.1	34.5	34.8	
	$F$	0.963	0.959	0.953	0.946	0.938	0.930	0.920	

increase of 50 lb. in pressure, the superheat and the vacuum being constant.

Constant.	Increase of	Increases Efficiency.
Pressure and vacuum	Superheat from 0 to 150°	0.5 to 0.6 av. 0.6
	“ “ 150 “ 300	0.9 “ 1.1 “ 1.0
Pressure and Superheat	Vacuum “ 27 “ 28	1.3 “ 1.5 “ 1.4
	“ “ 28 “ 29	2.2 “ 2.4 “ 2.3
Superheat and vacuum	Pressure “ 150 “ 200	1.4 “ 1.6 “ 1.5
	“ “ 200 “ 250	1.0 “ 1.2 “ 1.1

 W. H. Wallis (*Eng'g*, April 21, 1911) finds as the results of tests of a compound reaction turbine that the percentage reduction of steam consumption by increasing the vacuum from 25 in. to the figures given was as follows: Vacuum, 27 in.; reduction, 7 1/2%; 28 in., 12%; 28.6 in., 16%.

**Steam Consumption and Heat Consumption of the Ideal Engine.—**  
 If the Rankine cycle efficiency is given for a stated set of conditions,

the corresponding theoretical steam consumption per H. P.-hour may be found by the formula  $W = \frac{2546.5}{U} = \frac{2546.5}{E_R(H_S - h)}$

For the extreme cases in the table on p. 1090, we have:

Pressure, Lb.	Vac., In.	Superheat.	$H_S$ .	$h$ .	$E_R$ .	$U$ .	$W$ .	$H_S - h$	$W(H_S - h)$ .
150	27	0	1193.4	82.0	27.0	299.7	8.49	1114.4	9461
250	29	300°	1363.5	44.6	34.8	459.1	5.60	1318.9	7376

The figures in the last column,  $W(H_S - h)$ , show the B.T.U. consumed (or supplied by the boiler) per H.P.-hour. The number of pounds of steam supplied under the second set of conditions is 33.3% less than that supplied under the first set, but the saving of heat is only  $(9461 - 7376) \div 9461 = 22\%$ .

**Westinghouse Turbines at the Manhattan 74th Street Station, New York.**—Each of the 30,000 Kw. cross-compound units consists of two turbines, a high and a low pressure, side by side. Each half drives a generator, the high pressure running 1500 r.p.m. and the low pressure 750, the generators being tied together electrically. The turbines are reaction throughout, having no impulse wheel. The h.p. is a single flow machine and the l.p. a double flow. The turbines are to have a vacuum of 97% = 29.1 in. mercury, or 0.442 lb. per sq. in. absolute. The boilers will run at 215 lb. pressure, and at peak of the load, twice each day of 24 hours, will run at 300% of rating. Underfeed stokers. Superheat at throttle, 120°. (*Power*, April 27, 1915).

**A Steam Turbine Guarantee.**—A 22,500-Kw. steam turbine built in 1913 by C. A. Parsons Co., Newcastle, England, for the Commonwealth Edison Co., Chicago, was guaranteed as follows: At 750 r.p.m. 200 lb. pressure by gage, 29 in. vacuum in the condenser

Load, Kw.....	10,000	15,000	20,000	25,000
Steam per Kw.-hour, lb.....	12.50	11.65	11.25	11.65

**Efficiency of a 5000-Kw. Steam Turbine Generator.** (F. W. Ballard, *Trans. A. S. M. E.*, 1914.)—A plotted diagram of a series of tests shows that the total steam consumption at different loads follows the Willans straight-line law up to the point of maximum efficiency. The turbine was of the Allis-Chalmers-Parsons type, rated at 5000 Kw., 1800 r.p.m., 11,000 volts, A.C. With steam at 225 lb. gage, superheat 125° F., vacuum 28½ in., 90% power factor, the steam consumption at different loads was as follows (figures approximate, from the chart):

Load, Kw.....	2,000	4,000	5,000	6,000	6,500	7,000	7,900
Steam per Kw.-hour, lb.....	15.5	13.75	13.50	13.20	13.00	13.10	13.30
Total steam per hour, lb.....	31,000	55,000	67,500	79,000	85,000	91,500	105,000

Up to a load of 6500 Kw. the total consumption is 9000 + 12 × Kw. load, nearly. The efficiency ratio on the Rankine cycle was 0.68 at 6500 Kw.

**Comparison of Large Turbines and Reciprocating Engines.**—Moyer gives a set of curves of the steam consumption of a standard 5000-Kw. turbine generator and a 4-cylinder compound reciprocating steam-engine generator, assuming both units, operating under the same conditions. The following figures are taken from the curves:

Load in Kilowatts.....	3000	4000	5000	6000	7000	7500
	Lb. Steam per Kilowatt-hour.					
Turbine.....	16.0	15.5	15.3	15.25	15.4	15.5
Reciprocating engine:						
With equal work in cylinders.	18.0	17.4	17.8	19.0	20.8	22.0
Unequal work in cylinders..	18.4	17.0	17.2	17.5	18.4	19.0

**Steam Consumption of Small Steam Turbines.** — Small turbines, from 5 to 200 H.P., are extensively used for purposes where high speed of rotation is not an objection, such as for driving electric generators, centrifugal fans, etc., and where economy of fuel is not as important as saving of space, convenience of operation, etc. The steam consumption of these turbines varies as greatly as does that of small high-speed steam-engines, according to the design, speed, etc. A paper by Geo. A. Orrok in *Trans. A. S. M. E.*, 1909, discusses the details of several makes of machines. From a curve presented by R. H. Rice in discussion of this paper the following figures are taken showing the steam consumption in lbs. per B.H.P.-hour of different makes of impulse turbines.

Type.	Sturtevant.	Terry.	Bliss.	Bliss.	Kerr.	Curtis.	Curtis.	
Rated H.P.....	20	50	100	200	150	50	200	
Water rate at	{ 1/2 load....	72	59	58	55	52	44	32
	{ 3/4 load....	65	49	48	47	44	36	30
	{ Full load..	61	46	43	42	41	33	29
	{ 1 1/4 load..	58	44	40	39	39	31	28

Dry steam, 150 lbs. pressure; atmospheric exhaust.

Mr. Orrok shows that the steam consumption of these turbines largely depends on their peripheral speed. From a set of curves plotted with speed as the base it appears that the steam consumption per B.H.P.-hour ranges about as follows:

Peripheral speed, ft. per min.....	5,000	10,000	15,000	20,000	25,000
Steam per B.H.P.-hour	45 to 70	38 to 60	31 to 52	29 to 45	29 to 40

**Low-Pressure Steam Turbines.** — Turbines designed to utilize the exhaust steam from reciprocating engines are used to some extent. For steam at or below atmospheric pressure the turbine has a great advantage over reciprocating engines in its ability to expand the steam down to the vacuum pressure, while a reciprocating condensing engine generally does not expand below 8 or 10 lbs. absolute pressure. In order to expand to lower pressures the low-pressure cylinder would have to be inordinately large, and therefore costly, and the increased loss from cylinder condensation and radiation would more than counterbalance the gain due to greater expansion.

Mr. Parsons (*Proc. Inst. Nav. Arch.*, 1908) gives the following figures showing that the theoretical economy of the combination of a reciprocating engine and an exhaust steam turbine is about the same whether the turbine receives its steam at atmospheric pressure or at 7 lbs. absolute, the initial steam pressure in the engine being 200 lbs. absolute and the vacuum 28 ins.

Back pressure of engines, lbs. abs. ....	16	13 1/2	8	
Initial pressure, turbine, lbs. abs. ....	15	12 1/2	7	
Theoretical B.T.U. utilized per lb. of steam	{ in engine.....	178	189	218
	{ in turbine.....	142	131	100
	{ total.....	320	320	318

The following figures, by the General Electric Co., show the percentage over the output of a condensing reciprocating engine that may be made by installing a low-pressure turbine between the engine and the condenser, the vacuum being 28 1/2 ins.

Inches vacuum at admission valve.....	0	4	8	12	16	20	24
Per cent of work gained ...	26.1	26.5	26.8	26.3	25.3	23.6	20

It appears that a well-designed reciprocating compound engine working down to about atmospheric pressure is a more efficient machine than a turbine with the same terminal pressure, and that between the atmosphere and the condenser pressure the turbine is far more economical; therefore a combination of an engine and a turbine can be designed which will give higher economy than either an engine or a turbine working through the whole range of pressure.



When engines are run intermittently, such as rolling-mill and hoisting engines, their exhaust steam may be made to run low-pressure turbines by passing it first into a heat accumulator, or thermal storage system, where it gives up its heat to water, the latter furnishing steam continuously to the turbines. (See Thermal Storage, pages 927 and 1014.)

The following results of tests of a Westinghouse low-pressure turbine are reported by Francis Hodgkinson.

Steam press., lb. abs....	17.4	12.4	11.8	7.7	5.2	11.6	8.7	6.1	4.5
Vacuum, ins.	26.0	26.0	27.0	27.0	27.0	27.8	28.0	27.9	28.0
Brake H.P. .	920	472	592	321	102	586	458	234	114
Steam per B.H.P.-hr., lbs.....	27.9	37.1	29.9	37.3	64.4	28.0	30.4	38.6	54.8

Tests of a 1000-K.W. low-pressure double-flow Westinghouse turbine are reported to have given results as follows. (Approximate figures, from a curve.)

Load, Brake H.P.....	200	400	600	800	1000	1200	1500	2000	
Pressure at inlet, lbs. abs.....	4.1	5.1	6.1	7.2	8.3	9.4	11.0	13.5	
Steam per B.H.P.- hour, lbs. )	27½ in vac.	75	47.5	38	33	30	28	26.5	24.5
	28 in. vac.	62	42	33	29	27	25.5	24.5	22.5

The total steam consumption per hour followed the Willans law, being directly proportional to the power after adding a constant for 0 load, viz.: for 27½-in. vacuum the total steam consumption per hour was 12,000 lbs. + 18 × H.P., and for 28-in. vacuum, 9000 lbs. + 18 × H.P. (approx.).

The guaranteed steam consumption of a 7000-K.W. Rateau-Smoot low-pressure turbine generator is given in a curve by R. C. Smoot (*Power*, June 22, 1909), from which the following figures are taken. The admission pressure is taken at 16 lbs. absolute and the vacuum 28½ ins.

K.W. output.....	1500	2000	3000	4000	5000	6000	7000
Steam per K.W.-hr., lb....	40	37	32.5	29.5	27.6	26.2	25.7
Over-all efficiency, %.....	43	47	54	60	65	68	70

The performance of a combined plant of several reciprocating 2000-K.W. engines and a 7000-K.W. low-pressure turbine is estimated as follows, the engines expanding the steam from 215 to 16 lbs. absolute, and the turbines from 16 lbs. to 0.75 lb., the vacuum being 28.5 ins. with the barometer at 30 ins.

	Engine.	Turbine.
Theoretical steam per K.W.-hour, lbs .....	18	17.8
Steam per K.W.-hr. at switchboard, lbs .....	27.7	26.6
Combined efficiency of engine and dynamo, per cent. . .	65	67
Steam per K.W.-hour for combined plant = $1 \div (1/27.7 + 1/26.6) =$	13.6 lbs.	

The combined efficiency is 66%, representing the ratio of the energy at the switchboard to the available energy of the steam delivered to the engine and expanded down to the condenser pressure, after allowing for all losses in engine, turbine, and dynamo.

Very little difference is made in the plant efficiency if the intermediate pressure is taken anywhere from 3 or 4 lbs. below atmosphere to 15 or 20 lbs. above.

M. B. Carroll (*Gen. Elec. Rev.*, 1909) gives an estimate of the steam consumption of a combined unit of a 1000-K.W. engine and a low-pressure turbine. The engine, non-condensing, will develop 1000 H.P., with 32,000 lbs. of steam per hour. Allowing 8% for moisture in the exhaust, 29,440 lbs. of dry steam will be available for the turbine, which at 33 lbs. per K.W.-hour will develop 893 K.W., making a total output of 1893 K.W. for 32,000 lbs. steam, or 16.9 lbs. per K.W.-hour. The engine alone as a condensing engine will develop 1320 K.W. at 24.2 lbs. per K.W.-hour. The combined unit therefore develops 573 K.W., or 43.5% more than the condensing engine using the same amount of steam. The maximum capacity of the engine, non-condensing, is 1265 K.W., and condensing, 1470 K.W., and of the combined unit 2500 K.W.

**Tests of a 15,000 K.W. Steam-Engine-Turbine Unit** are reported by H. G. Stott and R. J. S. Pigott in *Jour. A.S.M.E.*, Mar., 1910. The steam-engine is one of the 7500 K.W. Manhattan type engines at the 59th St. station of the Rapid Transit Co., New York, with two 42-in. horizontal h.p. and two 86-in. vertical l.p. cylinders, and the turbine, also 7500 K.W., is of the vertical three-stage impulse type. The principal results are summarized as follows: An increase of 100% in the maximum capacity and 146% in the economical capacity of the plant; a saving of about 85% of the condensed steam for return to the boilers [it was previously wasted]; an average improvement in economy of 13% over the best high-pressure turbine results, and of 2.5% (between 7500 and 15,000 K.W.) over the results obtained by the engine alone; an average thermal efficiency between 6500 and 15,500 K.W. of 20.6%. [This efficiency is not quite equal to that reached by triple-expansion pumping engines. See page 806.]

**Reduction Gear for Steam Turbines.**—Double spiral reduction gears, usually of a ratio of 1 to 10, are used with the DeLaval turbine to obtain a velocity of rotation suitable for dynamos, centrifugal pumps, etc. G. W. Melville and J. H. McAlpine have designed a similar gear, with the pinion carried in a floating frame supported at a single point between the bearings to equalize the strain on the gear teeth, for reducing the speed of large horizontal turbines to suitable speeds for marine propellers. A 6000 H.P. gear with reduction from 1500 to 300 r.p.m. has given an efficiency of 98.5% (*Eng'g*, Sept. 17; *Eng. News*, Oct. 21 and Dec. 30, 1909).

**The Föttinger Transformer or Hydraulic Pinion** is an apparatus for reducing the speed of a propeller shaft below the speed of the steam-turbine shaft. It consists of a turbine wheel or water motor, mounted on the end of the propeller shaft, and a centrifugal pump mounted on the shaft of the steam turbine. The water is delivered by the pump to the motor and from the motor it passes to a tank and thence to the inlet of the pump. The ratio of reduction is determined by the design of the turbine and pump. The ratios hitherto applied range from 1.2:1 to 6:1. Reversing is accomplished by means of a second turbine on the propeller shaft, a valve directing the water to either the ahead or astern turbine as required. Hydraulic pinions transmitting 10,000 shaft horse-power have shown an over-all efficiency of about 92 per cent. An illustrated description will be found in *Engineering* of Sept. 25, 1914.

### HOT-AIR ENGINES.

**Hot-air (or Caloric) Engines.**—Hot-air engines are used to some extent, but their bulk is enormous compared with their effective power. For an account of the largest hot-air engine ever built (a total failure) see Church's Life of Ericsson. For theoretical investigation, see Rankin's Steam-engine and Roentgen's Thermodynamics. For description of constructions, see Appleton's Cyc. of Mechanics and Modern Mechanism, and Babcock on Substitutes for Steam, *Trans. A. S. M. E.*, vii, p. 693.

**Test of a Hot-air Engine (Robinson).**—A vertical double-cylinder (Caloric Engine Co.'s) 12 nominal H.P. engine gave 20.19 I.H.P. in the working cylinder and 11.38 I.H.P. in the pump, leaving 8.81 net I.H.P.; while the effective brake H.P. was 5.9, giving a mechanical efficiency of 67%. Consumption of coke, 3.7 lbs. per brake H.P. per hour. Mean pressure on pistons 15.37 lbs. per square inch, and in pumps 15.9 lbs., the area of working cylinders being twice that of the pumps. The air was supplied about 1160° F. and rejected at end of stroke about 890° F.

## INTERNAL-COMBUSTION ENGINES.

**References.**—For theory of the internal-combustion engine, see paper by Dugald Clerk, *Proc. Inst. C. E.*, 1882, vol. lxix; and Van Nostrand's Science Series, No. 62. See also Wood's Thermodynamics; Standard works on gas-engines are "A Text-book on Gas, Air, and Oil Engines," by Bryan Donkin; "The Gas and Oil Engine," by Dugald Clerk; "Internal Combustion Engines," by Carpenter and Diederichs; "Gas Engine Design," by C. E. Lucke; "Gas and Petroleum Engines," by W. Robinson; "The Modern Gas Engine and the Gas Producer," by A. M. Levin, and "The Gas Engine," by C. P. Poole. For practical operation of gas and oil engines, see "The Gas Engine," by F. R. Jones, and "The Gas Engine Handbook," by E. W. Roberts.

For descriptions of large gas-engines using blast furnace gas see papers in *Proc. Iron and Steel Inst.*, 1906, and *Trans. A. I. M. E.*, 1906. Many papers on gas-engines are in *Trans. A.S.M.E.*, 1905 to 1909.

**An Internal-combustion Engine** is an engine in which combustible gas, vapor, or oil is burned in a cylinder, generating a high temperature and high pressure in the gases of combustion, which expand behind a piston, driving it forward. (Rotary gas-engines or gas turbines, are still, 1915, in the experimental stage.)

**Four-cycle and Two-cycle Gas-Engines.**—In the ordinary type of single-cylinder gas-engine (for example the Otto) known as a four-cycle engine, one ignition of gas takes place in one end of the cylinder every two revolutions of the fly-wheel, or every two double strokes. The following sequence of operations takes place during four consecutive strokes: (a) inspiration of a mixture of gas and air during an entire stroke; (b) compression during the second (return) stroke; (c) ignition at or near the dead-point, and expansion during the third stroke; (d) expulsion of the burned gas during the fourth (return) stroke. Beau de Rochas in 1862 laid down the law that there are four conditions necessary to realize the best results from the elastic force of gas: (1) The cylinders should have the greatest capacity with the smallest circumferential surface; (2) the speed should be as high as possible; (3) the cut-off should be as early as possible; (4) the initial pressure should be as high as possible.

(Strictly speaking four-cycle should be called four-stroke-cycle, but the term four-cycle is generally used in the trade.)

The two great sources of waste in gas-engines are: 1. The high temperature of the rejected products of combustion; 2. Loss of heat through the cylinder walls to the water-jacket. As the temperature of the water-jacket is increased the efficiency of the engine becomes higher.

Fig. 178 is an indicator diagram of a four-cycle gas-engine. *AB*, the lower line, shows the admission of the mixture, at a pressure slightly below the atmosphere on account of the resistance of the inlet valve, *BC* is the compression in the clearance space, ignition taking place at *C* and combustion with increase of pressure continuing from *C* to *D*. The gradual termination of the combustion is shown by the rounded corner at *D*. *DE* is the expansion line, *EF* the line of pressure drop as the exhaust valve opens, and *FA* the line of expulsion of the burned gases, the pressure being slightly above the atmosphere on account of the resistance of the exhaust valve.

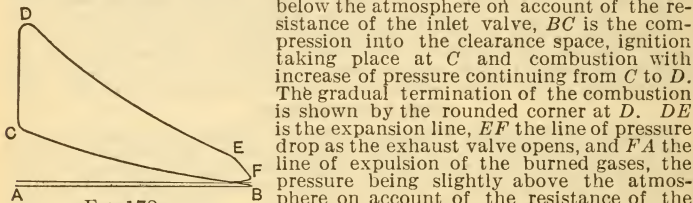

FIG. 178.

In a two-cycle single-acting engine an explosion takes place with every revolution, or with each forward stroke of the piston. Referring to the diagram Fig. 178 and beginning at *E*, when the exhaust port begins to open to allow the burned gases to escape, the pressure drops rapidly to *F*. Before the end of the stroke is reached an inlet port opens, admitting a mixture of gas and air from a reservoir in which it has been compressed. This mixture being under pressure assists in driving the burned gases out through the exhaust port. The inlet port and the exhaust port close early in the return stroke, and during the remainder of the stroke *BC* the mixture, which may include some of the burned gas, is compressed and the ignition takes place at *C*, as in the four-cycle engine.

In one form of the two-cycle engine only compressed air is admitted while the exhaust port is open, the fuel gas being admitted under pressure after the exhaust port is closed. By this means a greater proportion of the burned gases are swept out of the cylinder. This operation is known as "scavenging."

**Theoretical Pressures and Temperatures in Gas-Engines.**—Referring to Fig. 178, let  $P_s$  be the absolute pressure at *B*, the end of the suction stroke,  $P_c$  the pressure at *C*, the end of the compression stroke;  $P_x$  the maximum pressure at *D*, when the gases of combustion are at their highest temperature;  $P_e$  the pressure at *E*, when the exhaust valve begins to open. For the hypothetical case of a cylinder with walls incapable of absorbing or conducting heat, and of perfect and instantaneous combustion



or explosion of the fuel, an ideal diagram might be constructed which would have the following characteristics. In a four-cycle engine receiving a charge of air and gas at atmospheric pressure and temperature, the pressure at *B*, or  $P_s$ , would be 14.7 lbs. per sq. in. absolute, and the temperature say 62° F., or 522° absolute. The pressure at *C*, or  $P_c$ , would depend on the ratio  $V_1 \div V_2$ ,  $V_1$  being the original volume of the mixture in the cylinder before compression, or the piston displacement plus the volume of the clearance space, and  $V_2$  the volume after compression, or the clearance volume, and its value would be  $P_c = P_s (V_1/V_2)^n$ . The absolute temperature at the end of compression would be  $T_c = 522 \times (V_1/V_2)^{n-1}$ , or it may be found from the formula  $P_s V_s \div T_s = P_c V_c \div T_c$ , the subscripts *s* and *c* referring respectively to conditions at the beginning and end of compression. The compression would be adiabatic, and the value of the exponent *n* would be about the value for air, or 1.406. The work done in compressing the mixture would be calculated by the formula for compressed air (see page 634). The theoretical rise of temperature at the end of the explosion,  $T_x$ , above the temperature at the end of the compression  $T_c$  may be found from the formula  $(T_x - T_c) C_v = H$ , in which *H* is the amount of heat in British thermal units generated by the combustion of the fuel in 1 lb. of the mixture, and  $C_v$  the mean specific heat, at constant volume, of the gases of combustion between the temperatures  $T_x$  and  $T_c$ . Having obtained the temperature, the correspond-

ing pressure  $P_x$  may be found from the formula  $P_x = P_c \times (T_x/T_c)^{\frac{n}{n-1}}$ . In like manner the pressure and temperature at the end of expansion,  $P_e$  and  $T_e$ , and the work done during expansion, may be calculated by the formula for adiabatic expansion of air.

The ideal diagram of the adiabatic compression of air, instantaneous heating, and adiabatic expansion, differs greatly from the actual diagram of a gas-engine, and the pressures, temperatures, and amount of work done are different from those obtained by the method described above. In the first place the mixture at the beginning of the compression stroke is usually below atmospheric pressure, on account of the resistance of the inlet valve, in a four-cycle engine, but may be above atmospheric pressure in a two-cycle engine, in which the mixture is delivered from a receiver under pressure. Then the temperature is much higher than that of the atmosphere, since it is heated by the walls of the cylinder as it enters. The compression is not adiabatic, since heat is received from the walls during the first part of the stroke. If the clearance space is small and the pressure and temperature at the end of compression therefore high, the gas may give up some heat to the walls during the latter part of the stroke. The explosion is not instantaneous, and during its continuance heat is absorbed by the cylinder walls, and therefore neither the temperature nor the pressure found by calculation will be actually reached. Poole states that the rise in temperature produced by combustion is from 0.4 to 0.7 of what it would be with instantaneous combustion and no heat loss to the cylinder walls. Finally the expansion is not adiabatic, as the gases of combustion, at least during the first part of the expanding stroke, are giving up heat to the cylinder.

**Calculation of the Power of Gas-Engines.**—If the mean effective pressure in a gas-engine cylinder be obtained from an indicator diagram, its power is found by the usual formula for steam-engines, H.P. =  $PLAN \div 33,000$ , in which *P* is the mean effective pressure in lbs. per sq. in., *L* the length of stroke in feet, *A* the area of the piston in square inches, and *N* the number of explosion strokes per minute.

For purposes of design, however, the mean effective pressure either has to be assumed from a knowledge of that found in other engines of the same type and working under the same conditions as those of the design, or it may be calculated from the ideal air diagram and modified by the use of a coefficient or diagram factor depending on the kind of fuel used and the compression pressure. Lucke gives the following

factors for four-cycle engines by which the mean effective pressure of a theoretical air diagram is to be multiplied to obtain the actual M.E.P. for the several conditions named.

Kind of Fuel and Method of Use.	Compress- ion. Gauge Pressure.	Factor. Per Cent.
	Lb.	
Kerosene, when previously vaporized .....	45-75	30-40
Kerosene, injected on a hot bulb, may be as low as.....	.....	20
Gasoline, used in carburetor requiring a vacuum.....	.....	25-40
Gasoline, with but little initial vacuum.....	80-130	50-30
Producer gas.....	100-160	56-40
Coal gas.....	Av. 80	Av. 80
Blast-furnace gas.....	130-180	48-30
Natural gas.....	90-140	52-40

Factors for two-cycle engines are about 0.8 those for four-cycle engines.

**Pressures and Temperatures at end of Compression and at Release.**—The following tables, greatly condensed from very full tables given by C. P. Poole, show approximately the pressures and temperatures that may be realized in practice under different conditions. Poole says that the value of  $n$ , the exponent in the formula for compression, ranges from 1.2 to 1.38, these being extreme cases; the values most commonly obtained are from 1.28 to 1.35. The tables for compression pressures and temperatures are based on  $n = 1.3$  and 1.4, on compression ratios or  $V_1/V_2$  from 3 to 8, on absolute pressures in the cylinder before compression from 13 to 16 lbs., and on absolute temperatures before compression of 620° to 780° (160° to 320° F.). The release pressures and temperatures are based on values of  $n$  of 1.29 and 1.32, absolute pressures at the end of the explosion from 240 to 360 lbs. per sq. in., and absolute temperatures at the end of the explosion of 1800° to 3000° F.

COMPRESSION PRESSURES.

Compress- ion Ratio $r_c$	$n = 1.3.$					Compress- ion Ratio $r_c$	$n = 1.34.$				
	$P_s = 13$	13.5	14	15	16		$P_s = 13$	13.5	14	15	16
3.00	54.2	56.3	58.4	62.6	66.7	3.00	56.7	58.9	61.0	65.4	69.7
4.00	78.8	81.9	84.9	90.9	97.0	4.00	83.3	86.5	89.7	96.1	102.5
5.00	105.4	109.4	113.5	121.6	129.7	5.00	112.3	116.7	121.0	129.6	138.3
6.00	133.5	138.7	143.8	154.1	164.3	6.00	143.4	148.9	154.5	165.5	176.5
7.00	163.2	169.4	175.7	188.3	200.8	7.00	176.3	183.1	189.9	203.5	217.0
8.00	194.0	201.5	209.0	223.9	238.7	8.00	210.9	219.0	227.1	243.4	259.6

COMPRESSION TEMPERATURES.

Compress- ion Ratio $r_c$	$n = 1.3.$					Compress- ion Ratio $r_c$	$n = 1.34.$				
	$T_s = 620^\circ$	660°	700°	740°	780°		$T_s = 620^\circ$	660°	700°	740°	780°
3.00	862	918	973	1029	1084	3.00	901	959	1017	1075	1133
4.00	940	1000	1061	1122	1182	4.00	993	1057	1122	1186	1250
5.00	1005	1070	1134	1199	1264	5.00	1072	1141	1210	1279	1348
6.00	1061	1130	1198	1267	1335	6.00	1140	1214	1287	1361	1434
7.00	1112	1183	1255	1327	1398	7.00	1201	1279	1357	1434	1512
8.00	1157	1232	1306	1381	1456	8.00	1257	1338	1420	1501	1582

## ABSOLUTE PRESSURES PER SQUARE INCH AT RELEASE.

Corresponding to Explosion Pressures commonly obtained.

NOTE:—The expansion ratios in the left-hand column are based on the volume behind the piston when the exhaust valve begins to open.

Expansion Ratio $r_e$ .	$n_e = 1.29$ .					Expansion Ratio $r_e$ .	$n_e = 1.32$ .				
	Value of $P_x$						Value of $P_x$				
	240	270	300	330	360		240	270	300	330	360
3.00	58.2	65.4	72.7	80.0	87.2	3.00	56.3	63.3	70.4	77.4	84.4
4.00	40.1	45.2	50.2	55.2	60.2	4.00	38.5	43.3	48.1	52.9	57.8
5.00	30.1	33.9	37.6	41.4	45.1	5.00	28.7	32.3	35.8	39.4	43.0
6.00	23.8	26.8	29.7	32.7	35.7	6.00	22.5	25.4	28.2	31.0	33.8
7.00	19.5	21.9	24.4	26.8	29.2	7.00	18.4	20.7	23.0	25.3	27.6
8.00	16.4	18.5	20.5	22.6	24.6	8.00	15.4	17.3	19.3	21.2	23.1

## ABSOLUTE TEMPERATURES AT RELEASE.

Corresponding to Explosion Temperatures commonly obtained.

Expansion Ratio $r_e$ .	$n_e = 1.29$ .					Expansion Ratio $r_e$ .	$n_e = 1.32$ .				
	Value of $T_x$						Value of $T_x$				
	1800	2100	2400	2700	3000		1800	2100	2400	2700	3000
3.00	1309	1527	1745	1963	2182	3.00	1266	1478	1689	1900	2111
4.00	1204	1405	1606	1806	2007	4.00	1155	1348	1540	1733	1925
5.00	1129	1317	1505	1693	1881	5.00	1075	1255	1434	1613	1792
6.00	1070	1249	1427	1606	1784	6.00	1015	1184	1353	1522	1691
7.00	1024	1194	1365	1536	1706	7.00	966	1127	1288	1449	1610
8.00	985	1149	1313	1477	1641	8.00	925	1079	1234	1388	1542

**Pressures and Temperatures after Combustion.**—According to Poole, the maximum temperature after combustion may be as high as 3000° absolute, F., and the maximum pressure as high as 400 lbs. per sq. in. absolute; these are high figures, however, the more usual figures being about 2300° and 250 lbs. Poole gives the following figures for the average rise in pressure, above the pressure at the end of compression, produced by combustion of different fuels, with different ratios of compression.

## AVERAGE PRESSURE RISE IN LBS. PER SQ. IN. PRODUCED BY COMBUSTION.

Comp. Ratio.	Illum. Gas 650 B.T.U.*	Gasoline.	Kerosene.	Comp. Ratio.	Natural Gas 1000 B.T.U.*	Comp. Ratio.	Producer Gas 150 B.T.U.*	Comp. Ratio.	Blast-Furnace Gas 100 B.T.U.*
4.0	146	195	168	5.0	192	6.0	225	7.0	211
4.2	156	208	179	5.2	202	6.2	234	7.2	218
4.4	166	221	190	5.4	211	6.4	243	7.4	225
4.6	175	234	202	5.6	221	6.6	252	7.6	232
4.8	185	247	213	5.8	230	6.8	261	7.8	239
5.0	195	260	224	6.0	240	7.0	270	8.0	246

\* Per cubic foot measured at 32° F.

The following figures are given by Poole as a rough approximate guide to the mean effective pressures in lbs. per sq. in. obtained with



different fuels and different compression pressures in a four-cycle engine. In a two-cycle engine the mean effective pressure of the pump diagram should be subtracted. The delivery pressure is usually from 4 to 8 lbs. per sq. in. above the atmosphere, and the corresponding mean effective pressure of the pump about 3.8 to 7.

PROBABLE MEAN EFFECTIVE PRESSURE.

SUCTION ANTHRACITE PRODUCER GAS.						MOND PRODUCER GAS.					
Engine H.P.	Compression Pressure, abs. lbs. per sq. in.					Engine H.P.	Compression Pressure.				
	100	115	130	145	160		100	115	130	145	160
10	55	60	65	...	...	10	...	65	65	65	...
25	60	65	70	75	...	25	60	65	65	70	75
50	65	70	75	80	80	50	65	70	70	75	80
100	70	75	80	85	85	100	65	70	75	80	85
250	75	80	85	90	90	250	70	75	80	85	90
500	80	85	90	90	90	500	75	80	85	90	90

NATURAL AND ILLUMINATING GASES.

Engine H.P.	Compression Pressure.					Engine H.P.	Compression Pressures.				
	65	75	85	100	115		75	85	100	115	130
10	60	65	70	75	...	100	80	85	90	95	100
25	65	70	75	80	85	250	85	90	95	100	105
50	70	75	80	90	90	500	...	95	100	105	110

KEROSENE SPRAY.

Engine H.P.	Compression Pressures.				
	65	75	85	100	115
5	50	55	60	65	70
10	55	60	65	70	75
25	60	65	70	75	80
50	65	70	75	80	85

GASOLINE VAPOR.

Engine H.P.	Compression Pressures.				
	65	75	85	100	
5	70	75	80	85	...
10	75	80	85	90	...
25	80	85	90	90	...
50	85	90	95	95	...

Sizes of Large Gas Engines. — From a table of sizes of the Nürnberg gas engine, as built by the Allis-Chalmers Co., the following figures are taken. These figures relate to two-cylinder tandem double-acting engines.

Diam. cyl., ins.....	18	20	21	22	24	24	26	28	30	32
Stroke cyl., ins.....	24	24	30	30	30	36	36	36	42	42
Revs. per min.....	150	150	125	125	125	115	115	115	100	100
Piston speed, ft. per min.....	600	600	625	625	625	690	690	690	700	700
Rated B.H.P.....	260	320	370	405	490	545	630	740	855	985
Factor C.....	0.8	0.8	0.84	0.84	0.85	0.95	0.93	0.94	0.95	0.96
Diam., ins.....	34	36	38	40	42	44	46	48	50	52
Stroke, ins.....	42	48	48	48	54	54	54	60	60	62
Revs. per min.....	100	92	92	92	86	86	86	78	78	78
Piston speed.....	700	736	736	736	774	774	774	780	780	780
Rated B.H.P.....	1105	1300	1460	1630	1875	2080	2280	2475	2720	2950
Factor C.....	0.96	1	1.01	1.02	1.06	1.07	1.08	1.07	1.09	1.09

The figures "factor C" are the values of C in the equation B.H.P. = C × D<sup>2</sup>, in which D = diam. of cylinder in ins. For twin-cylinder double-acting engines, multiply the B.H.P. and the value of C by 0.95; for twin-

tandem double-acting engines, multiply by 2; for two-cylinder single-acting, or for single-cylinder double-acting engines, divide by 2; for single-acting single-cylinders, divide by 4. The figures for B.H.P. correspond to mean effective pressures of about 66, 68, and 70 lbs. per sq. in. for 20, 40, and 50 in. cylinders respectively if we assume 0.85 as the mechanical efficiency, or the ratio B.H.P.  $\div$  I.H.P.

**Engine Constants for Gas Engines.**—The following constants for figuring the brake H.P. of gas engines are given in *Power*, Dec. 7, 1909. They refer to four-stroke cycle single-cylinder engines, single acting; for double-acting engines multiply by 2. Producer gas, 0.000056. Illuminating gas, 0.000065. Natural gas, 0.00007. Constant  $\times$  diam.<sup>2</sup>  $\times$  stroke in ins.  $\times$  revs. per min. = probable B.H.P. A deduction should be made for the space occupied by the piston rods, about 5% for small engines up to 10% for very large engines.

**Rated Capacity of Automobile Engines.**—The standard formula for the American Licensed Automobile Manufacturers Association (called the A. L. A. M. formula) for approximate rating of gasoline engines used in automobiles is Brake H.P. = Diam.<sup>2</sup>  $\times$  No. of cylinders  $\div$  2.5. It is based on an assumed piston speed of 1000 ft. per min. The following ratings are derived from the formula:

Bore, ins . . . . .	2 1/2	3	3 1/2	4	4 1/2	5	5 1/2	6
Bore, mm . . . . .	64	76	89	102	114	127	140	154
H.P., 1 cylinder . . .	2 1/2	3.6	4.9	6.4	8.1	10	12.1	14.4
H.P., 2 cylinders . . .	5	7.2	9.8	12.8	16.2	20	24.2	28.8
H.P., 4 " . . . . .	10	14.4	19.6	25.6	32.4	40	48.4	57.6
H.P., 6 " . . . . .	15	21.6	29.4	38.4	48.6	60	72.6	86.4

A committee of the Institution of Automobile Engineers recommends the following formula: B.H.P. = 0.45 ( $d + s$ ) ( $d - 1.18$ ) $N$ , in which  $d$  = diam., in.,  $s$  = stroke, in.,  $N$  = number of cylinders. The formula was derived from the results of tests of engines in first-class condition on the test bench. For ordinary engines on the road the result should be multiplied by 0.6. (*Eng'g*, Feb. 10, 1911.)

The American Power Boat Association's formula for rating 2-cycle engines is H.P. = area of piston  $\times$  number of cylinders  $\times$  length of stroke  $\times$  1.5.

**Approximate Estimate of the Horse-power of a Gas Engine.**—From the formula I.H.P. =  $PLAN \div 33,000$ , in which  $P$  = mean effective pressure in lbs. per sq. in.,  $L$  = length of stroke in ft.,  $A$  = area of piston in sq. ins.,  $N$  = No. of explosion strokes per min., we have I.H.P. =  $Pd^2S \div 42,017$ , in which  $d$  = diam. of piston, and  $S$  = piston speed in ft. per min., for an engine in which there are two explosion strokes in each revolution, as in a 4-cycle double-acting, 2-cylinder engine, or a 2-cycle, 2-cylinder, single-acting engine. If the mechanical efficiency is taken at 0.84, then the brake horse power B.H.P. =  $Pd^2S \div 50,000$ . Under average conditions the product of  $P$  and  $S$  is in the neighborhood of 50,000, and in that case B.H.P. =  $d^2$ . Generally, B.H.P. =  $C \times d^2$ , in which  $C$  is a coefficient having values as below:

M.E.P. Lbs. per Sq. In.	Piston Speed, Ft. per Minute.					
	500	600	700	800	900	1000
	Value of $C$ for Two Explosions per Revolution.					
50	0.50	0.60	0.70	0.80	0.90	1.00
60	0.60	0.72	0.84	0.96	1.08	1.20
70	0.70	0.84	0.98	1.12	1.26	1.40
80	0.80	0.96	1.12	1.28	1.44	1.60
90	0.90	1.08	1.26	1.44	1.62	1.80
100	1.00	1.20	1.40	1.60	1.80	2.00
110	1.10	1.32	1.54	1.76	1.98	2.20

These values of  $C$  apply to 4-cylinders, 4-cycle, single-acting, to 2-cyl., 2-cycle, single-acting, and to 1-cyl., 2-cycle double-acting. For single cylinders, 4-cycle, single-acting, divide by 4; for single cylinders, 4-cycle, double-acting, or 2-cycle, single-acting, divide by 2.

**Oil and Gasoline Engines.**—The lighter distillates of petroleum, such as gasoline, are easily vaporized at moderate temperatures, and a gasoline engine differs from a gas-engine only in having an atomizer attached

for spraying a fine jet of the liquid into the air-admission pipe. With kerosene and other heavier distillates, or crude oils, it is necessary to provide some method of atomizing and vaporizing the oil at a high temperature, such as injecting it into a hot vaporizing chamber at the end of the cylinder, or into a chamber heated by the exhaust gases.

**The Diesel Oil Engine.**—The distinguishing features of the Diesel engine are: It compresses air only, to a predetermined temperature above the firing point of the fuel. This fuel is blown as a cloud of vapor (by air from a separate small compressor) into the cylinder when compression has been completed, ignites spontaneously without explosion, solely by reason of the heat of the air generated by the compression, and burns steadily with no essential rise in pressure. The temperature of gases, developed and rejected, is much lower than with engines of the explosive type. The engine uses crude oil and residual petroleum products. Guarantees of fuel consumption are made as low as 8 gallons of oil (not heavier than 19° Baumé) for each 100 brake H.P. hour at any load between half and full rated load.

American Diesel engines are built for stationary purposes, in sizes of 120, 170, and 225 H.P. in three cylinders, and in "double units" (six cylinders) of 240, 340 and 450 H.P. See catalogue of the American Diesel Engine Co., St. Louis, 1909.

Much larger sizes have been built in Europe, where they are also built for marine purposes, including submarines in the French and other navies. For the theory of the Diesel engine see a lecture by Rudolph Diesel, in *Zeit. des Ver. Deutscher Ing.*, 1897, trans. in *Progressive Age*, Dec. 1 and 15, 1897, and paper by E. D. Meier in *Jour. Frank. Inst.*, Oct. 1898.

**The De La Vergne Oil Engine** is described in *Eng. News*, Jan. 13, 1910. It is a four-cycle engine. After the charge of air is compressed to about 200 lbs. per sq. in., the charge of oil is injected, by a jet of air at about 600 lbs. per sq. in., into a vaporizing bulb at the end of the cylinder. Ignition of the oil is caused by the high temperature in this bulb. Average results of tests of an engine developing 128 H.P. showed an oil consumption per B.H.P. hour of 0.408 lb. with Solar fuel oil, and 0.484 lb. with California crude oil.

**Alcohol Engines.**—Bulletin No. 392 of the U.S. Geol. Survey (1909.) on Comparisons of Gasolene and Alcohol Tests in Internal Combustion Engines, by R. M. Strong, contains the following conclusions:

The "low" heat value of completely denatured alcohol will average 10,500 B.T.U. per lb., or 71,900 B.T.U. per gallon. The low heat value of 0.71 to 0.73 sp. gr. gasolene will average 19,200 B.T.U. per lb., or 115,800 B.T.U. per gallon.

A gasolene engine having a compression pressure of 70 lbs. but otherwise as well suited to the economical use of denatured alcohol as gasolene, will, when using alcohol, deliver about 10% greater maximum power than when using gasolene.

When the fuels for which they are designed are used to an equal advantage, the maximum B.H.P. of an alcohol engine having a compression pressure of 180 lbs. is about 30% greater than that of a gasolene engine of the same size and speed having a compression pressure of 70 lbs.

Alcohol diluted with water in any proportion, from denatured alcohol, which contains about 10% water, to mixtures containing about as much water as denatured alcohol, can be used in gasolene and alcohol engines if the engines are properly equipped and adjusted.

When used in an engine having constant compression, the amount of pure alcohol required for any given load increases and the maximum available horse-power of the engine decreases with diminution in the percentage of pure alcohol in the diluted alcohol supplied. The rate of increase and decrease, respectively, however, is such that the use of 80% alcohol instead of 90% has but little effect upon the performance; so that if 80% alcohol can be had for 15% less cost than 90% alcohol and could be sold without tax when denatured, it would be more economical to use the 80% alcohol.

**Ignition.**—The "hot-tube" method of igniting the compressed mixture of gas and air in the cylinder is practically obsolete, and electric systems are used instead. Of these the "make-and-break" and the "jump-spark" systems are in common use. In the former two insulated contact



pieces are located in the end of the cylinder, and through them an electric current passes while they are in contact. A spark-coil is included in the circuit, and when the circuit is suddenly broken at the proper time for ignition, by mechanism operated from the valve-gear shaft, a spark is made at the contacts, which ignites the gas. In the "jump-spark" system two insulated terminals separated about 0.03 in. apart are located in the cylinder, and the secondary or high-tension current of an induction coil causes a spark to jump across the space between them when the circuit of the primary current is closed by mechanism operated by the engine. In some oil engines the mixture of air and oil vapor is ignited automatically by the temperature generated by compression of the vapor, in a chamber at the end of the cylinder, called the vaporizer, which is not water-jacketed and therefore is kept hot by the repeated ignitions. Before starting the engine the vaporizer is heated by a Bunsen burner or other means.

**Timing.** — By adjusting the cam or other mechanism operated by the valve-gear shaft for causing ignition, the time at which the ignition takes place, with reference to the end of the compression stroke, can be regulated. The mixture is usually ignited before the end of the stroke, the advance depending upon the inflammability of the mixture and on the speed of the engine. A slow-burning mixture requires to be ignited earlier than a rapid-burning one and a high-speed earlier than a slow-speed engine.

**Governing.** — Two methods of governing the speed of an engine are in common use, the "hit-and-miss" and the throttling methods. In the former the engine receives its usual charge of air and gas only when the engine is running at or below its normal speed; at higher speeds the admission of the charge is suspended until the engine regains its normal speed. One method of accomplishing this is to interpose between the valve-rod and its cam or other operating mechanism, a push-rod, or other piece, the position of which with reference to the end of the valve-rod is controlled by a centrifugal governor so that it hits the valve-rod if the speed is at or below normal and misses it if the speed is above normal. The hit-and-miss method is economical of fuel, but it involves irregularity of speed, making a large and heavy fly-wheel necessary if reasonable uniformity of speed is desired. The throttling method of regulating is similar to that used in throttling steam engines; the quantity of mixture admitted at each charge being varied by varying the position of a butterfly valve in the inlet pipe. Cut-off methods of governing are also used, such as varying the time of closing the admission valve during the suction stroke, or varying the time of admission of the gas alone, or "quality regulation."

**Gas and Oil Engine Troubles.** — The gas engine is subject to a greater number of troubles than the steam engine on account of its greater mechanical complexity and of the variable quality of its operating fluid. Among the causes of troubles are: the variable composition of the fuel; too much or too little air supply; compression ratio not right for the kind of fuel; ignition timer set too late or too early; pre-ignition; back-firing; electrical and mechanical troubles with the igniting system; carbon deposits in the cylinder and on the igniting contacts. For a very full discussion of these and many other troubles and the remedies for them, see Jones on the Gas-Engine.

**Conditions of Maximum Efficiency.** — The conditions which appear to give the highest thermal efficiency in gas and oil engines are: 1, high temperature of cooling water in the jackets; 2, high pressure at the end of compression; 3, lean mixture; 4, proper timing of the ignition; 5, maximum load. The higher economy of a lean mixture may be due to the fact that high compressions may be used with such a mixture, while with rich mixtures high compression pressures cannot be used without danger of pre-ignition. The effect of different timing on economy is shown in a test by J. R. Bibbins, reported by Carpenter and Diederichs, of an engine using natural gas of a lower heating value\* of 934 B.T.U. per cu. ft., delivering 71 H.P. at 297 revs. per min. The maximum thermal efficiency, 23.3%, was obtained when the timing device was set for igni-

\* By "lower heating value" is meant the value computed after subtracting the latent heat of evaporation of 9 lbs. of water per pound of hydrogen contained in the gas. See page 561.

tion 30° in advance of the dead center, while the efficiency with ignition at the center was 19%, and with ignition 55° in advance 17.3%.

Other things being equal, the hotter the walls of the cylinder the less heat is transferred into them from the hot gases, and therefore the higher the efficiency. Cool walls, however, allow of higher compression without pre-ignition, and high compression is a cause of high efficiency. Cool walls also tend to give the engine greater capacity, since with hot walls the fuel mixture expands more on entering the cylinder, reducing the weight of charge admitted in the suction stroke.

**Heat Losses in the Gas Engine.**—The difference between the thermal efficiency, which is the proportion of heat converted into work in the engine, and 100%, is the loss of heat, which includes the heat carried away in the jacket water, that carried away in the waste gases, and that lost by radiation. The relative amounts of these three losses vary greatly, depending on the size of the engine and on the amount of water used for cooling. Thurston, in *Heat as a Form of Energy*, reports a test in which the heat distribution was as follows: Useful work, 17.3%; jacket water, 52%; exhaust gas, 16%; radiation, 15%. Carpenter and Diederichs quote the following, showing that the distribution of the heat losses varies with the rate of compression and with the speed.

Ratio of Compression.	R.p.m.	M.E.P. lbs. per sq. in.	Ratio Air to Gas.	Heat-ing Value of Charge, B.T.U.	Work done by 1 B.T.U., Ft.-lbs.	Ex-haust Temp. Deg. F.	Heat Distribution, Per Cent.		
							Work.	Jacket Water.	Ex-haust.
2.67	187	54.3	7.11	18.5	140	1022	18.0	51.2	30.8
2.67	247	51.5	7.35	17.4	141	1137	18.1	45.6	36.3
4.32	187	69.3	7.43	17.0	190	867	24.4	53.8	21.8
4.32	247	65.2	7.40	16.8	184	992	23.7	49.5	26.8

In the long table of results of tests reported by Carpenter and Diederichs, figures of the distribution of heat show that of the total heat received by the engines the heat lost in the jacket water ranged from 25.0 to 50.4%, and that lost in the exhaust gases from 55 to 23.4%.

In small air-cooled gasoline engines, such as those used in some automobile engines, in which the cylinders are surrounded by thin metal ribs to increase the radiating surface, and air is propelled against them by a fan, the air takes the place of the jacket water, and the total loss of heat is that carried away by the air and by the exhaust gases.

**Economical Performance of Gas Engines.**—The best performance of a gas engine using producer gas (1909) is about 30% better than the best recorded performance of a triple-expansion steam engine, or about 0.71 lb. coal per I.H.P. hour, as compared with 1.06 lbs. for the steam engine. It is probable that the performance of the combination of a high-pressure reciprocating engine, using superheated steam generated in a well-proportioned boiler supplied with mechanical stokers and an economizer, and a low-pressure steam turbine will ere long reduce the steam engine record to 0.9 lb. per I.H.P. hour. As compared with an ordinary steam engine, however, the gas engine with a good producer is far more economical than the steam engine. Where gas can be obtained cheaply, such as the waste-gas from blast furnaces, or natural gas, the gas-engine can furnish power much more cheaply than it can be obtained from the same gas burned under a boiler to furnish steam to a steam engine.

In tests made for the U. S. Geological Survey at the St. Louis Exhibition, 1904, of a 235-H.P. gas engine with different coals, made into gas in the same producer, the best result obtained was 1.12 lbs. of West Virginia coal per B.H.P. hour, and the poorest result 3.23 lbs. per B.H.P. hour, with North Dakota lignite.

A 170-H.P. Crossley (Otto) engine tested in England in 1892, using producer gas, gave a consumption of 0.85 lb. coal per I.H.P. hour, or a thermal efficiency of engine and producer combined of 21.3%.

Experiments on a Taylor gas producer using anthracite coal and a

100-H.P. Otto gas engine showed a consumption of 0.97 lb. carbon per I.H.P. hour. (*Iron Age*, 1893.)

In a table in Carpenter and Diederichs on Internal Combustion Engines the lowest recorded coal consumption per B.H.P. hour is 0.71 lb., with a Tange engine and a suction gas producer, using Welsh anthracite coal. Other tests show figures ranging from 0.74 lb. to 1.95, the last with a Westinghouse 500-H.P. engine and a Taylor producer using Colorado bituminous coal.

In the same book are given the following figures of the thermal efficiency on brake H.P. with different gas and liquid fuels. Illuminating gas, 6 tests, 16.1 to 31.0%; natural gas, 4 tests, 16.1 to 29.0%; coke-oven gas, 1 test, 27.5%; Mond gas, 1 test, 23.7%; blast-furnace gas, 3 tests, 20.4 to 28.2%; gasoline, 8 tests, 10.2 to 28%; kerosene, Diesel engine, 3 tests, 25.8 to 31.9%; kerosene, other engines, 8 tests, 9.2 to 19.7%; crude oil, Diesel engine, 1 test, 28.1%; alcohol, 4 tests, 21.8 to 32.7%.

Tests of Diesel engines operating centrifugal pumps in India are reported in *Eng. News*, Nov. 25, 1909. Using Borneo petroleum residue of 0.934 sp. gr., and a fuel value of 18,600 B.T.U. per lb., an average of 151 B.H.P. during a season, for a total of 6003 engine hours, was obtained with a consumption of 0.462 lb. of fuel per B.H.P. hour, or one B.H.P. for about 8600 B.T.U. per hour, equal to a thermal efficiency of 29.5%. The pump efficiency at maximum lift of 14 to 16 ft. was 70%, and the fuel consumption per water H.P. hour at the same lift was 0.7 lb.

**Utilization of Waste Heat from Gas Engines.**—The exhaust gases from a gas engine may be used to heat air by passing them across a nest of tubes through which air is flowing. A design of this kind, for heating the Ives library building, New Haven, Conn., by Harrison Engineering Co., New York, is illustrated in *Heat. and Vent. Mag.*, Jan., 1910.

The waste heat might also be used in a boiler to generate steam at or below atmospheric pressure, for use in a low pressure steam turbine. On account of the comparatively low temperature of the exhaust gases, however, the boiler would require a much greater extent of heating surface for a given capacity than a boiler with an ordinary coal-fired furnace.

## RULES FOR CONDUCTING TESTS OF GAS AND OIL ENGINES\*. CODE OF 1902.

(From the report of the committee of the A. S. M. E. on Engine Tests.)

[Only a brief abstract is here given. The items, 1, Objects of the Tests; 2, General Conditions of the Engine; 3, Dimensions; 5, Calibration of Instruments, are practically the same as in the report on Steam Engine Tests.]

IV. *Fuel.* — Decide upon the gas or oil to be used, and if the trial is to be made for maximum efficiency, the fuel should be the best of its class that can readily be obtained, or one that shows the highest calorific power.

VI. *Duration of Test.* — The duration of a test should depend largely upon the objects in view, and in any case the test should be continued until the successive readings of the rates at which oil or gas is consumed, taken at say half-hourly intervals, become uniform and thus verify each other. If the object is to determine the working economy, and the period of time during which the engine is usually in motion is some part of twenty-four hours, the duration of the test should be fixed for this number of hours. If the engine is one using coal for generating gas, the test should be of at least twenty-four hours' duration.

VII. *Starting a Test.* — In a test for determining the maximum economy of an engine, it should first be run a sufficient time to bring all the conditions to a normal and constant state.

If a test is made to determine the performance under working conditions, the test should begin as soon as the regular preparations have been made for starting the engine in practical work, and the measurements should then commence and be continued until the close of the period covered by the day's work.

VIII. *Measurement of Fuel.* — If the fuel used is coal furnished to a gas

\* Hot-air engines are not included in this code, those in the market being of comparatively small size, and seldom tested.



producer, the same methods apply for determining the consumption as are used in steam-boiler tests.

If the fuel used be gas, the only practical method of measurement is the use of a meter through which the gas is passed. The temperature and pressure of the gas should be measured, and the quantity of gas should be determined by reference to the calibration of the meter, taking into account the temperature and pressure of the gas.

If the fuel is oil, this can be drawn from a tank which is filled to the original level at the end of the test, the amount of oil required for so doing being weighed; or, for a small engine, the oil may be drawn from a calibrated vertical pipe.

**IX. Measurement of Heat-Units Consumed by the Engine.** — The number of heat-units used is found by multiplying the number of pounds of coal or oil or the cubic feet of gas consumed, by the total heat of combustion of the fuel as determined by a calorimeter test. In determining the total heat of combustion no deduction is made for the latent heat of the water vapor in the products of combustion.

It is sometimes desirable, also, to have a complete chemical analysis of the oil or gas. The total heat of combustion may be computed, if desired, from the results of the analysis, and should agree well with the calorimeter values.

**X. Measurement of Jacket Water.** — The jacket water may be measured by passing it through a water meter or allowing it to flow from a measuring tank before entering the jacket, or by collecting it in tanks on its discharge.

**XI. Indicated Horse-power.** — The directions given for determining the indicated horse-power for steam engines apply in all respects to internal combustion engines.

**XII. Brake Horse-power.** — The determination of the brake horse-power is the same for internal combustion as for steam engines.

**XIII. Speed.** — The same directions apply to internal combustion engines as to steam engines for the determination of speed.

In an engine which is governed by varying the number of explosions or working cycles, a record should be kept of the number of explosions per minute; or if the engine is running at nearly maximum load, by counting the number of times the governor causes a miss in the explosions.

**XIV. Recording the Data.** — The pressures, temperatures, meter readings, speeds, and other measurements should be observed every 20 or 30 minutes when the conditions are practically uniform, and at more frequent intervals if they are variable. Observations of the gas or oil measurements should be taken with special care at the expiration of each hour, so as to divide the test into hourly periods, and reveal the uniformity, or otherwise, of the conditions and results as the test goes forward.

**XV. Uniformity of Conditions.** — When the object of the test is to determine the maximum economy, all the conditions relating to the operation of the engine should be maintained as constant as possible during the trial.

**XVI. Indicator Diagrams.** — Sample diagrams nearest to the mean should be selected from those taken during the trial and appended to the tables of the results. If there are separate compression or feed cylinders, the indicator diagrams from these should be taken and the power deducted from that of the main cylinder.

**XVII. Standards of Economy and Efficiency.** — The hourly consumption of heat, divided by the indicated or the brake horse-power, is the standard expression of engine economy recommended.

In making comparisons between the standard for internal combustion engines and that for steam engines, it must be borne in mind that the steam engine standard does not cover the losses due to combustion, while the internal combustion engine standard, in cases where a crude fuel such as oil is burned in the cylinder, does cover these losses.

The thermal efficiency ratio per indicated horse-power or per brake horse-power for internal combustion engines is expressed by the fraction

$$2545 \div \text{B.T.U. per H.P. per hour.}$$

**XVIII. Heat Balance.** — For purposes of scientific research, a heat balance should be drawn which shows the manner in which the total

heat of combustion is expended in the various processes concerned in the working of the engine. It may be divided into three parts: first, the heat which is converted into the indicated or brake work; second, the heat rejected in the cooling water of the jackets; and third, the heat rejected in the exhaust gases, together with that lost through incomplete combustion and radiation.

To determine the first item, the number of foot-pounds of work performed by, say, one pound or one cubic foot of the fuel, divided by 778, gives the number of heat-units desired. The second item is determined by measuring the amount of cooling water passed through the jackets, equivalent to one pound or one cubic foot of fuel consumed, and multiplying this quantity by the difference in the sensible heat of the water leaving the jacket and that entering. The third item is obtained by subtracting the sum of the first two items from the total heat supplied. The third item can be subdivided by computing the heat rejected in the exhaust gases as a separate quantity. The data for this computation are found by analyzing the fuel and the exhaust gases, or by measuring the quantity of air admitted to the cylinder in addition to that of the gas or oil.

XIX. *Report of Test.* — The data and results of a test should be reported in the manner outlined in one of the following tables, the first of which gives a complete summary when all the data are determined, and the second is a shorter form of report in which some of the minor items are omitted. [The short form is given below.]

DATA AND RESULTS OF STANDARD HEAT TEST OF GAS OR OIL ENGINE.

Arranged according to the Short Form advised by the Engine Test Committee, American Society of Mechanical Engineers. Code of 1902.

1. Made by ..... of.....  
on engine located at.....  
to determine.....
2. Date of trial.....
3. Type and class of engine.....
4. Kind of fuel used.....
  - (a) Specific gravity..... deg Fahr.
  - (b) Burning point..... "
  - (c) Flashing point..... "
5. Dimensions of engine:
 

	1st Cyl.	2d Cyl.
(a) Class of cylinder (working or for compressing the charge).....		
(b) Single or double acting.....		
(c) Cylinder dimensions:		
Bore.....		in.
Stroke.....		ft.
Diameter piston rod.....		in.
(d) Average compression space, or clearance, in per cent.....		
(e) Horse-power constant for one lb. M.E.P. and one revolution per minute.....		

*Total Quantities.*

6. Duration of test..... hours
7. Gas or oil consumed..... cu. ft. or lbs.
8. Cooling water supplied to jackets..... "
9. Calorific value of fuel by calorimeter test, determined by ..... calorimeter..... B.T.U.

*Pressures and Temperatures.*

10. Pressure at meter (for gas engine) in inches of water... ins.
11. Barometric pressure of atmosphere:
  - (a) Reading of barometer..... "
  - (b) Reading corrected to 32 degs. Fahr..... "

- 12. Temperature of cooling water:
  - (a) Inlet . . . . . deg. Fahr.
  - (b) Outlet . . . . . "
- 13. Temperature of gas at meter (for gas engine) . . . . . "
- 14. Temperature of atmosphere:
  - (a) Dry bulb thermometer . . . . . "
  - (b) Wet bulb thermometer . . . . . "
  - (c) Degree of humidity . . . . . "
- 15. Temperature of exhaust gases . . . . . "

*Data Relating to Heat Measurement.*

- 16. Heat units consumed per hour (pounds of oil or cubic feet of gas per hour multiplied by the total heat of combustion) . . . . . B.T.U.
- 17. Heat rejected in cooling water per hour . . . . . "

*Speed, etc.*

- 18. Revolutions per minute . . . . . rev.
- 19. Average number of explosions per minute . . . . .

*Indicator Diagrams.*

- 20. Pressure in lbs. per sq. in. above atmosphere:
 

	1st Cyl.	2d Cyl.
(a) Maximum pressure . . . . .		
(b) Pressure just before ignition . . . . .		
(c) Pressure at end of expansion . . . . .		
(d) Exhaust pressure . . . . .		
(e) Mean effective pressure . . . . .		

*Power.*

- 21. Indicated horse-power:
 

First cylinder . . . . .	H.P.
Second cylinder . . . . .	"
Total . . . . .	"
- 22. Brake horse-power . . . . . "
- 23. Friction horse-power by friction diagrams . . . . . "
- 24. Percentage of indicated horse-power lost in friction . . . . . per cent.

*Standard Efficiency, and Other Results.*

- 25. Heat units consumed by the engine per hour:
 

(a) Per indicated horse-power . . . . .	B.T.U.
(b) Per brake horse-power . . . . .	"
- 26. Pounds of oil or cubic feet of gas consumed per hour:
 

(a) Per indicated horse-power . . . . .	lbs. or cu. ft.
(b) Per brake horse-power . . . . .	

*Additional Data.*

Add any additional data bearing on the particular objects of the test or relating to the special class of service for which the engine is to be used. Also give copies of indicator diagrams nearest the mean, and the corresponding scales.

LOCOMOTIVES.

**Resistance of Trains.**—*Resistance due to Speed.*—Various formulæ and tables for the resistance of trains at different speeds on a straight level track have been given by different writers. Among these are the following:

By D. L. Barnes, *Eng. Mag.*, June, 1894:

Speed, miles per hour . . . . .	50	60	70	80	90	100
Resistance, pounds per gross ton . . . . .	12	12.4	13.5	15	17	20

By *Engineering News*, March 8, 1894:

Resistance in lbs. per ton of 2000 lbs. =  $\frac{1}{4}v + 2$ .

Speed . . . . .	5	10	15	20	25	30	35	40	50	60	70	80	90	100
Resistance . . . . .	3 1/4	4.5	5 3/4	7	8 1/4	9.5	10 3/4	12	14.5	17	19.5	22	24.5	27



This formula seems to be more generally accepted than the others. It gives results too small, however, below 10 miles an hour. At starting, the resistance is about 17 lbs. per ton, dropping to 4 or 5 lbs. at 5 miles an hour.

By Baldwin Locomotive Works:

Resistance in lbs. per ton of 2000 lbs. =  $3 + v + 6$ .

Speed . . . . .	5	10	15	20	25	30	35	40	45	50	55	60	70	80	90	100
Resistance.	3.8	4.7	5.5	6.3	7.2	8	8.8	9.7	10.5	11.3	12.2	13	14.7	16.3	18	19.7

The resistance due to speed varies with the condition of the track, the number of cars in a train, and other conditions.

For tables showing that the resistance varies with the area exposed to the resistance and friction of the air per ton of loads, see Dashiell, *Trans. A. S. M. E.*, vol. xiii. p. 371.

P. H. Dudley (Bulletin International Ry. Congress, 1900, p. 1734) shows that the condition of the track is an important factor of train resistance which has not hitherto been taken account of. The resistance of heavy trains on the N. Y. Central R. R. at 20 miles an hour is only about  $3\frac{1}{2}$  lbs. per ton on smooth 80-lb.  $5\frac{1}{8}$ -in. rails. The resistance of an 80-car freight train, 60,000 lbs. per car, as given by indicator cards, at speeds between 15 and 25 miles per hour, is represented by the formula  $R = 1 + \frac{1}{8} V$ , in which  $R$  = resistance in lbs. per ton and  $V$  = miles per hour. These values are much below the average and should not be used in estimating the hauling power needed.

*New Formulæ for Resistance.* — The Amer. Locomotive Co. (Bulletin No. 1001, Feb., 1910) states that the figures obtained from the old formulæ for train resistance are much too high for modern loaded freight cars of 40 to 50 tons capacity, and in some instances too low for very light or empty cars. The best data available show that the resistance varies from about 2.5 to 3 lbs. per ton (of 2000 lbs.) for 72-ton cars (including weight of empty car) to 6 to 8 lbs. for 20-ton cars. From speeds between 5 to 10 and 30 to 35 miles an hour, the resistance of freight cars is practically constant. The resistance of the engine and tender is figured separately, and is composed of the following factors: (a) Engine friction = 22.2 lbs. per ton, or 1.11% of the weight on drivers. (b) Head air resistance = cross-sectional area (taken at 120 sq. ft.)  $\times$  0.002  $V^2$ ,  $V$  being the speed in miles per hour. (c) Resistance due to weight on engine trucks and trailing wheels, and to the tender, the same per ton as that due to the cars. (d) Grade resistance = 20 lbs. per ton for each per cent of grade. (e) Curve resistance, which varies with the wheel-base of the locomotive, and is taken as  $0.4 + cD$  lbs. per ton, in which  $D$  is the degree of the curve and  $c$  a constant whose value is,

For wheel-base, ft.	5	6	7	8	9	12	13	15	16	20
Value of $c$ . . . . .	0.380	.415	.460	.485	.520	.625	.660	.730	.765	.905

The sum of these resistances is to be deducted from the tractive force of the locomotive to obtain the available tractive force for overcoming the resistance of the cars. (See Tractive Force, below.) The maximum tractive force is taken for low speeds at 85% of that due to the boiler pressure; for piston speeds over 250 ft. per min. this is to be multiplied by a speed factor to obtain the actual force. Speed factors and percentages of maximum horse-power corresponding to different piston speeds are given below.  $S$  = piston speed, ft. per min.,  $F$  = speed factor,  $P$  = % of maximum H.P.

$S$ . . . . .	250	300	350	400	450	500	550	600	650	700	750
$F$ . . . . .	1.00	.954	.908	.863	.817	.772	.727	.680	.636	.592	.550
$P$ . . . . .	60.4	69.1	77.2	83.7	89.0	93.5	96.8	98.7	99.7	100	100
$S$ . . . . .	800	850	900	950	1000	1100	1200	1300	1400	1500	1600
$F$ . . . . .	0.517	.487	.460	.435	.412	.372	.337	.307	.283	.261	.241
$P$ . . . . .	100	100	100	100	100	99	97.8	96.8	95.7	94.7	93.5

The resistance of freight cars, according to experiments on the Penna. R.R., varies with the weight in tons per car as follows:

Tons per car . . . . .	10	20	25	30	40	50	60	70	72
Resistance, lbs. per ton	13.10	7.84	6.62	5.78	4.66	3.94	3.44	3.06	3.00

From plotted curves of resistances of trains of empty and loaded cars the following figures are derived.  $R$  = resistance in lbs. per ton.

Wt. loaded, tons.....	75	70	65	60	55	50
Wt. empty, tons.....	21	20.3	19.5	18.6	17.6	16.5
Per cent of loaded wt.....	28	29	30	31	32	33
$R$ loaded .....	2.90	3.07	3.24	3.43	3.65	3.90
$R$ empty .....	5.63	5.82	6.00	6.26	6.50	6.85
Wt. loaded, tons.....	45	40	35	30	25	20
Wt. empty, tons.....	15.3	14.0	12.6	11.1	9.5	7.8
Per cent of loaded wt....	34	35	36	37	38	39
$R$ loaded .....	4.18	4.40	4.74	5.07	5.44	5.91
$R$ empty .....	7.26	7.65	8.05	8.45	9.05	9.60

The resistance of passenger cars is derived from the formula  $R = 5.4 + 0.002(V - 15)^2 + 100 \div (V + 2)^3$ .  $V$  in miles per hour,  $R$  = resistance in lbs. per ton (2000 lbs.) H.P. = horse-power per ton.

$V$ = .....	5	10	15	20	25	30	35
$R$ = .....	5.89	5.51	5.42	5.46	5.60	5.85	6.20
H.P. = .....	0.079	.147	.217	.291	.374	.469	.578

$V$ = .....	40	45	50	60	70	80	90
$R$ = .....	6.65	7.20	7.85	9.45	11.45	13.85	16.65
H.P. = .....	.709	.864	1.047	1.515	2.135	2.95	4.00

*Resistance of Electric Railway Cars and Trains.* — W. J. Davis, Jr. (*Street Ry. Jour.*, Dec. 3, 1904), gives as a result of numerous experiments the following formulæ:

(A) For light open platform street cars, 8 tons to 20 tons; maximum speed, 30 miles per hour; cross-section, 85 sq. ft.

$$R = 6 + 0.11V + \frac{0.3V^2}{T} [1 + 0.1(n - 1)].$$

(B) For standard interurban electric cars, 25 tons to 40 tons; maximum speed, 60 m.p.h.; cross section, 100 sq. ft.

$$R = 5 + 0.13V + 0.3V^2/T [1 + 0.1(n - 1)].$$

(C) For heavy interurban electric cars, or steam passenger coaches, 40 tons to 50 tons; maximum speed, 75 m.p.h.; cross-section, 110 sq. ft.

$$R = 4 + 0.13V + 0.33V^2/T [1 + 0.1(n - 1)].$$

(D) For heavy freight trains, cars weighing 45 tons loaded; maximum speed, 35 m.p.h.; average cross-section, 110 sq. ft.

$$R = 3.5 + 0.13V + 0.385V^2/T [1 + 0.1(n - 1)].$$

$R$  = resistance in lbs. per ton of 2000 lbs.,  $V$  = speed in miles per hour  $T$  = weight of train in tons,  $n$  = number of cars in train, including leading motor car. The cross-section includes the space bounded by the wheels between the top of rails and the body.

*Resistance due to Grade.* — The resistance due to a grade of 1 ft. per mile is, per ton of 2000 lbs.,  $2000 \times 1/5280 = 0.3788$  lb. per ton, or if  $R_g$  = resistance in lbs. per ton due to grade and  $G$  = ft. per mile  $R_g = 0.3788G$ .

If the grade is expressed as a percentage of the length, the resistance is 20 lbs. per ton for each per cent of grade.

*Resistance due to Curves.* — Mr. G. R. Henderson in his book entitled "Locomotive Operation" gives the resistance due to curvature at 0.7 lb. per ton of 2000 lbs. per degree of the curve. (For definition of degrees of a railroad curve see p. 54.) For locomotives, this factor is sometimes doubled, making the resistance in lbs. per ton =  $0.7c$  for cars and  $1.4c$  for locomotives,  $c$  being the number of degrees.

The Baldwin Locomotive Works take the approximate resistance due to each degree of curvature as that due to a straight grade of  $1\frac{1}{2}$  ft. per mile. This corresponds to  $R_c = 0.5682c$ .

The Amer. Locomotive Co. takes 0.8 lb. per ton per degree of curvature for the resistance of cars on curves.

For mine cars, with short wheel-bases and wheels loose on the axles, experiments quoted by the Baldwin Locomotive Works, 1904, lead to the formula, Resistance due to curvature, in pounds, =  $0.20 \times \text{wheel-base} \times \text{weight of loaded cars in pounds} \div \text{radius of curve in feet}$ .

*Resistance due to Acceleration.* — This may be calculated by the ordinary formula (see page 529), or reduced to common railroad units, and including the rotative energy of wheels and axles, which increases the effect of the weight of the cars by an equivalent of about 5%, we have

$$P = 70 \frac{V^2}{S} = 95.6 \frac{V}{t} = 70 \frac{V_2^2 - V_1^2}{S}, \text{ where } P = \text{the accelerating force in}$$

pounds per ton,  $V$  = the velocity in miles per hour,  $S$  = the distance in feet, and  $t$  = the time in seconds in which the acceleration takes place.  $V_1$  and  $V_2$  = the smaller and greater velocities, respectively, in miles per hour, for a change of speed.

*Total Resistance.* — The total resistance in lbs. per ton of 2000 lbs. due to speed, to grade, to curves, and to acceleration is the sum of the resistances calculated above.

The Baldwin Locomotive Works in their "Locomotive Data" take the total resistance on a straight level track at slow speeds at from 6 to 10 lbs. per ton, and in a communication printed in the fourth edition (1898) of this Pocket-book, p. 1076, say: "We know that in some cases, for instance in mine construction, the frictional resistance has been shown to be as much as 60 lbs. per ton at slow speed. The resistance should be approximated to suit the conditions of each individual case, and the increased resistance due to speed added thereto."

*Resistance due to Friction.* — In the above formulæ no account has been taken of the resistance due to the friction of the working parts. This is rather an obscure subject. Mr. Henderson estimates the percentage of the indicated power consumed by friction to be  $0.15 V + c$ , where  $V$  = speed in miles per hour and  $c$  = a constant, whose value may vary from 2 to 8, the latter figure being the safest to use for heavy work at slow speeds. Ordinarily 8% of the indicated power is consumed by internal resistance under these conditions. Professor Goss gives the following formula, obtained from tests at the Purdue locomotive testing laboratory:

Let  $d$  = diameter of cylinder;  $S$  = stroke of piston;  $D$  = diameter of drivers, all in inches. Then the internal friction =  $3.8 d^2 S / D$ , in pounds at the circumference of the drivers.

Concerning the effect of increasing speed on tractive force, Mr. Henderson says (1906):

From a number of tests and information from various roads and authorities it seems as if, for ordinary simple engines, the coefficient 0.8

in the equation Actual tractive force =  $\frac{0.8 P d^2 s}{D}$  could be modified in accordance with the speed in order to obtain the actual tractive force at various speeds about as follows:

Revs. per min. =	20	40	60	80	100	120	140	160	
Coefficient =	0.80	0.80	0.80	0.70	0.61	0.53	0.46	0.40	
Revs. per min. =	180	200	220	240	260	280	300	320	340
Coefficient =	0.35	0.31	0.28	0.26	0.24	0.23	0.21	0.20	0.19

**Efficiency of the Mechanism of a Locomotive.** — Frank C. Wagner (*Proc. A. A. A. S.*, 1900, p. 140) gives an account of some dynamometer tests which indicate that in ordinary freight service the power used to drive the locomotive and tender and to overcome the friction of the mechanism is from 10% to 35% of the total power developed in the steam-cylinder. In one test the weight of the locomotive and tender was 16% of the total weight of the train, while the power consumed in the locomotive and tender was from 30% to 33% of the indicated horse-power.

**Adhesion.** — The limit of the hauling capacity of a locomotive is the adhesion due to the weight on the driving wheels. Holmes gives the adhesion, in English practice, as equal to 0.15 of the load on the driving wheels in ordinary dry weather, but only 0.07 in damp weather or when the rails are greasy. In American practice it is generally taken as from  $\frac{1}{4}$  to  $\frac{1}{5}$  of the load on the drivers.



**Tractive Force of a Locomotive. — Single Expansion.**

Let  $F$  = indicated tractive force in lbs.

$p$  = average effective pressure in cylinder in lbs. per sq. in.

$S$  = stroke of piston in inches.

$d$  = diameter of cylinders in inches.

$D$  = diameter of driving-wheels in inches. Then

$$F = \frac{4 \pi d^2 p S}{4 \pi D} = \frac{d^2 p S}{D}.$$

The average effective pressure can be obtained from an indicator-diagram, or by calculation, when the initial pressure and ratio of expansion are known, together with the other properties of the valve-motion. The subjoined table from Auchincloss gives the proportion of mean effective pressure to boiler-pressure above atmosphere for various proportions of cut-off.

Stroke, Cut-off at —	M.E.P. (Boiler- pres. = 1).	Stroke, Cut-off at—	M.E.P. (Boiler- pres. = 1).	Stroke, Cut-off at —	M.E.P. (Boiler- pres. = 1).
0.1	0.15	0.333 = 1/3	0.5 = 1/2	0.625 = 5/8	0.79
.125 = 1/8	.2	.375 = 3/8	.55	.666 = 2/3	.82
.15	.24	.4	.57	.7	.85
.175	.28	.45	.62	.75 = 3/4	.89
.2	.32	.5 = 1/2	.67	.8	.93
.25 = 1/4	.4	.55	.72	.875 = 7/8	.98
.3	.46				

These values were deduced from experiments with an English locomotive by Mr. Gooch. As diagrams vary so much from different causes, this table will only fairly represent practical cases. It is evident that the cut-off must be such that the boiler will be capable of supplying sufficient steam at the given speed.

We can, however, allow for wire drawing to the steam chest and drop in pressure due to expansion, and internal friction by writing the formula: Actual Tractive Force =  $\frac{0.8 P d^2 S}{D}$ ,  $d$ ,  $S$ , and  $D$  being as before and  $P$  representing boiler pressure in lbs. per sq. in.

**Compound Locomotives.** — The Baldwin Locomotive Works give the following formulæ for compound engines of the Vaucrain four-cylinder type:

$$T = \frac{C^2 S \times 2/3 P}{D} + \frac{c^2 S \times 1/4 P}{D}.$$

$T$  = tractive force in lbs.  $C$  = diam. of high-pressure cylinder in ins.  $c$  = diam. of low-pressure cylinder in ins.  $P$  = boiler-pressure in lbs.  $S$  = stroke of piston in ins.  $D$  = diam. of driving-wheels in ins.

For a two-cylinder or cross-compound engine it is only necessary to consider the high-pressure cylinder, allowing a sufficient decrease in boiler pressure to compensate for the necessary back-pressure. The formula is

$$T = \frac{C^2 S \times 2/3 P}{D}.$$

The above formulæ are for speeds of from 5 to 10 miles an hour, or less; above that the capacity of the boiler limits the cut-off which can be used, and the available tractive force is rapidly reduced as the speed increases. For a full discussion of this, see page 375 of Henderson's "Locomotive Operation."

**The Size of Locomotive Cylinders** is usually taken to be such that the engine will just overcome the adhesion of its wheels to the rails under favorable circumstances.

The adhesion is taken by a committee of the Am. Ry. Master Mechanics' Assn. as 0.25 of the weight on the drivers for passenger engines, 0.24 for freight, and 0.22 for switching engines; and the mean effective pressure in the cylinder, when exerting the maximum tractive force, is taken at 0.85 of the boiler-pressure.

Let  $W$  = weight on drivers in lbs.;  $P$  = tractive force in lbs., = say  $0.25 W$ ;  $p_1$  = boiler-pressure in lbs. per sq. in.;  $p$  = mean effective pressure, =  $0.85 p_1$ ;  $d$  = diam. of cylinder,  $S$  = length of stroke, and  $D$  = diam. of driving-wheels, all in inches. Then

$$W = 4P = \frac{4 d^2 p S}{D} = \frac{4 d^2 \times 0.85 p_1 S}{D}$$

Whence 
$$d = 0.5 \sqrt{\frac{DW}{pS}} = 0.542 \sqrt{\frac{DW}{p_1 S}}$$

Von Borries's rule for the diameter of the low-pressure cylinder of a compound locomotive is  $d^2 = 2 Z D \div ph$ , in which  $d$  = diameter of l.p. cylinder in inches;  $D$  = diameter of driving-wheel in inches;  $p$  = mean effective pressure per sq. in., after deducting internal machine friction;  $h$  = stroke of piston in inches;  $Z$  = tractive force required, usually 0.14 to 0.16 of the adhesion.

The value of  $p$  depends on the relative volume of the two cylinders, and from indicator experiments may be taken as follows:

Class of Engine.	Ratio of Cylinder Volumes.	$p$ in percent of Boiler-pressure.	$p$ for Boiler-pressure of 176 lbs.
Large-tender eng's.	1 : 2 or 1 : 2.05	42	74
Tank-engines.....	1 : 2 or 1 : 2.2	40	71

**Horse-power of a Locomotive.** — For each cylinder the horse-power is  $H.P. = pLaN \div 33,000$ , in which  $p$  = mean effective pressure,  $L$  = stroke in feet,  $a$  = area of cylinder =  $1/4 \pi d^2$ ,  $N$  = number of single strokes per minute,  $LN$  = piston speed, ft. per min. Let  $M$  = speed of train in miles per hour,  $S$  = length of stroke in inches, and  $D$  = diameter of driving-wheel in inches. Then  $LN = M \times 88 \times 2 S \div \pi D$ . Whence for the two cylinders the horse-power is

$$\frac{2 \times p \times 1/4 \pi d^2 \times 176 S \times M}{\pi D \times 33,000} = \frac{pd^2SM}{375 D}$$

REVOLUTIONS PER MINUTE FOR VARIOUS DIAMETERS OF WHEELS AND SPEEDS.

Diameter of Wheel.	Miles per Hour.							
	10	20	30	40	50	60	70	80
50 in.	67	134	201	268	336	403	470	538
56 in.	60	120	180	240	300	360	420	480
60 in.	56	112	168	224	280	336	392	448
62 in.	54	108	162	217	271	325	379	433
66 in.	51	102	153	204	255	306	357	408
68 in.	49	99	148	198	247	296	346	395
72 in.	47	93	140	187	233	279	326	373
78 in.	43	86	129	172	215	258	301	344
80 in.	42	84	126	168	210	252	294	336
84 in.	40	80	120	160	200	240	280	320
90 in.	37	75	112	150	186	224	261	299

**The Size of Locomotive Boilers.** (Forney's Catechism of the Locomotive.) — They should be proportioned to the amount of adhesive weight and to the speed at which the locomotive is intended to work. Thus a locomotive with a great deal of weight on the driving-wheels could pull a heavier load, would have a greater cylinder capacity than one with little adhesive weight, would consume more steam, and therefore should have a larger boiler.

The weight and dimensions of locomotive boilers are in nearly all cases determined by the limits of weight and space to which they are necessarily confined. It may be stated generally that *within these limits a locomotive boiler cannot be made too large.* In other words, boilers for

locomotives should always be made as large as is possible under the conditions that determine the weight and dimensions of the locomotives. (See also Holmes on the Steam-engine, pp. 371 to 377 and 383 to 389, and the Report of the Am. Ry. M. M. Ass'n. for 1897, pp. 218 to 232.)

Holmes gives the following from English practice:

Evaporation, 9 to 12 lbs. of water from and at 212°.

Ordinary rate of combustion, 65 lbs. per sq. ft. of grate per hour.

Ratio of grate to heating surface, 1 : 60 to 90.

Heating surface per lb. of coal burnt per hour, 0.9 to 1.5 sq. ft.

Mr. Henderson states the approximate heating surface needed per indicated horse-power as follows:

Compound Locomotives.....	2 square feet.
Simple Locomotives (cut-off $\frac{1}{2}$ stroke or less) .....	$2\frac{1}{3}$ square feet.
Simple Locomotives; (cut-off $\frac{1}{2}$ to $\frac{3}{4}$ stroke).....	$2\frac{2}{3}$ square feet.
Simple Locomotives (full stroke).....	3 square feet.

For the ratio of heating surface to grate area the Master Mechanics Ass'n Committee of 1902 advised as below:

Fuel.	Passenger.		Freight.	
	Simple.	Compound.	Simple.	Compound.
Free burning bituminous.....	65 to 90	75 to 95	70 to 85	65 to 85
Average bituminous.....	50 to 65	60 to 75	45 to 70	50 to 65
Slow burning bituminous.....	40 to 50	35 to 60	35 to 45	45 to 50
Bituminous slack and free burning.. anthracite.....	35 to 40	30 to 35	30 to 35	40 to 45
Low grade bituminous, lignite and slow burning anthracite.....	28 to 35	24 to 30	25 to 30	30 to 40

A. E. Mitchell, (*Eng'g News*, Jan. 24, 1891) says: Square feet of boiler-heating surface for bituminous coal should not be less than 4 times the square of the diameter in inches of a cylinder 1 inch larger than the cylinder to be used. One tenth of this should be in the fire-box. On anthracite locomotives more heating-surface is required in the fire-box, on account of the larger grate-area required, but the heating-surface of the flues should not be materially decreased.

**Wootten's Locomotive.** (Clark's Steam-engine; see also *Jour. Frank. Inst.* 1891, and *Modern Mechanism*, p. 485.) — J. E. Wootten designed and constructed a locomotive boiler for the combustion of anthracite and lignite, though specially for the utilization as fuel of the waste produced in the mining and preparation of anthracite. The special feature of the engine is the fire-box, which is made of great length and breadth, extending clear over the wheels, giving a grate-area of from 64 to 85 sq. ft. The draught diffused over these large areas is so gentle as not to lift the fine particles of the fuel. A number of express-engines having this type of boiler are engaged on the fast trains between Philadelphia and Jersey City. The fire-box shell is 8 ft. 8 in. wide and 10 ft. 5 in. long; the fire-box is  $8 \times 9\frac{1}{2}$  ft., making 76 sq. ft. of grate-area. The grate is composed of bars and water-tubes alternately. The regular types of cast-iron shaking grates are also used. The height of the fire-box is only 2 ft. 5 in. above the grate. The grate is terminated by a bridge of fire-brick, beyond which a combustion-chamber, 27 in. long, leads to the flue-tubes, about 184 in number,  $1\frac{3}{4}$  in. diam. The cylinders are 21 in. diam., with a stroke of 22 inches. The driving-wheels, four-coupled, are 5 ft. 8 in. diam. The engine weighs 44 tons, of which 29 tons are on driving wheels. The heating-surface of the fire-box is 135 sq. ft., that of the flue-tubes is 982 sq. ft.: together, 1117 sq. ft., or 14.7 times the grate-area. Hauling 15 passenger-cars, weighing with passengers 360 tons, at an average speed of 42 miles per hour, over ruling gradients of 1 in 89, the engine consumes 62 lbs. of fuel per mile, or  $34\frac{1}{4}$  lbs. per sq. ft. of grate per hour.



**Grate-surface, Smoke-stacks, and Exhaust-nozzles for Locomotives.** — A. E. Mitchell, Supt. of Motive Power of the Erie R. R., says (1895) that some roads use the same size of stack, 13½ in. diam. at throat, for all engines up to 20 in. diam. of cylinder.

The area of the orifices in the exhaust-nozzles depends on the quantity and quality of the coal burnt, size of cylinder, construction of stack, and the condition of the outer atmosphere. It is therefore impossible to give rules for computing the exact diameter of the orifices. All that can be done is to give a rule by which an approximate diameter can be found. The exact diameter can only be found by trial. Our experience leads us to believe that the area of each orifice in a double exhaust-nozzle should be equal to 1/400 part of the grate-surface, and for single nozzles 1/200 of the grate-surface. These ratios have been used in finding the diameters of the nozzles given in the following table. The same sizes are often used for either hard or soft coal-burners. [These sizes are small at the present day (1909) as locomotives have enormously increased in size.]

Size of Cylinders, in inches.	Grate-area for Anthracite Coal, in sq. in.	Grate-area for Bituminous Coal, in sq. in.	Diameter of Stacks, in inches.	Double Nozzles.	Single Nozzles.
				Diam. of Orifices, in inches.	Diam. of Orifices, in inches.
12×20	1591	1217	9 1/2	2	2 13/16
13×20	1873	1432	10 1/2	2 1/8	3
14×20	2179	1666	11 1/4	2 5/16	3 1/4
15×22	2742	2097	12 1/2	2 9/16	3 11/16
16×24	3415	2611	14	2 7/8	4 1/16
17×24	3856	2948	15	3 1/16	4 5/16
18×24	4321	3304	15 3/4	3 1/4	4 5/8
19×24	4810	3678	16 1/2	3 7/16	4 13/16
20×24	5337	4081	17 1/2	3 5/8	5 1/16

**Exhaust-nozzles in Locomotive Boilers.** — A committee of the Am. Ry. Master Mechanics' Ass'n. in 1890 reported that they had, after two years of experiment and research, come to the conclusion that, owing to the great diversity in the relative proportions of cylinders and boilers, together with the difference in the quality of fuel, any rule which does not recognize each and all of these factors would be worthless.

The committee was unable to devise any plan to determine the size of the exhaust-nozzle in proportion to any other part of the engine or boiler. The conditions desirable are: That it must create draught enough on the fire to make steam, and at the same time impose the least possible amount of work on the pistons in the shape of back pressure. It should be large enough to produce a nearly uniform blast without lifting or tearing the fire, and be economical in its use of fuel. The Annual Report of the Association for 1896 contains interesting data on this subject.

Much important information regarding stacks and exhaust nozzles is embodied in the tests at Purdue University, reported to the Master Mechanics' Ass'n. in 1896 and in the tests reported in the *American Engineer* in 1902 and 1903.

**Fire-brick Arches in Locomotive Fire-boxes.** — A committee of the Am. Ry. Master Mechanics' Ass'n. in 1890 reported strongly in favor of the use of brick arches in locomotive fire-boxes. They say: It is the unanimous opinion of all who use bituminous coal and brick arch, that it is most efficient in consuming the various gases composing black smoke, and by impeding and delaying their passage through the tubes, and mingling and subjecting them to the heat of the furnace, greatly lessens the volume ejected, and intensifies combustion, and does not in the least check but rather augments draught, with the consequent saving of fuel and increased steaming capacity that might be expected from such results. This in particular when used in connection with extension front.

Arches now (1909) are not quite so much in favor, largely on account of the difficulty and delay caused to workmen when flues must be calked, as occurs frequently in bad water districts, and some of their former advocates are now omitting them altogether.

**Economy of High Pressures.** — Tests of a Schenectady locomotive with cylinders 16 X 24 ins., at the Purdue University locomotive testing plant, gave results as follows: (*Eng. Digest*, Mar., 1909; Bull. No. 26, Univ. of Ill. Expt. Station).

Boiler pressure, lbs. per sq. in.	120	140	160	180	200	220	240
Steam per 1 H.P. hour, lbs.	29.1	27.7	26.6	26.	25.5	25.1	24.7
Coal per 1 H.P. hour, lbs.	4	3.77	3.59	3.50	3.43	3.37	3.31

In the same series of tests the economy of the boiler at different rates of driving and different pressures was determined, the results leading to the formula  $E = 11.305 - 0.221 H$ , in which  $E =$  lbs. evaporated from and at 212" per lb. of Youghiogheny coal, and  $H$  the equivalent evaporation per sq. ft. of heating surface per hour, with an average error for any pressure which does not exceed 2.1%.

### Leading American Types of Locomotive for Freight and Passenger Service.

1. The eight-wheel or "American" passenger type, having four coupled driving-wheels and a four-wheeled truck in front.
2. The "ten-wheel" type, for mixed traffic, having six coupled drivers and a leading four-wheel truck.
3. The "Mogul" freight type, having six coupled driving-wheels and a pony or two-wheel truck in front.
4. The "Consolidation" type, for heavy freight service, having eight coupled driving-wheels and a pony truck in front.

Besides these there is a great variety of types for special conditions of service, as four-wheel and six-wheel switching-engines, without trucks; the Forney type used on elevated railroads, with four coupled wheels under the engine and a four-wheeled rear truck carrying the water-tank and fuel; locomotives for local and suburban service with four coupled driving-wheels, with a two-wheel truck front and rear, or a two-wheel truck front and a four-wheel truck rear, etc. "Decapod" engines for heavy freight service have ten coupled driving-wheels and a two-wheel truck in front.

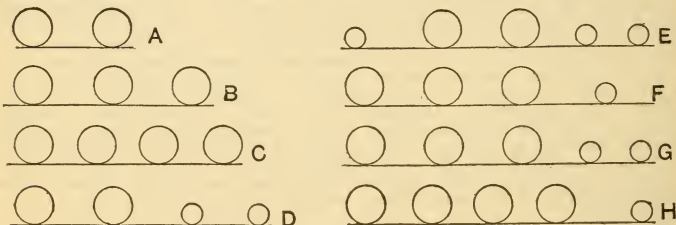

**Classification of Locomotives** (Penna. R. R. Co., 1900). — Class A, two pairs of drivers and no truck. Class B, three pairs of drivers and no truck. Class C, four pairs of drivers and no truck. Class D, two pairs of drivers and four-wheel truck. Class E, two pairs of drivers, four-wheel truck, and trailing wheels. Class F, three pairs of driving-wheels and two-wheel truck. Class G, three pairs of drivers and four-wheel truck. Class H, four pairs of drivers and two-wheel truck. Class A is commonly called a "four-wheeler"; B, a "six-wheeler"; D, an "eight-wheeler," or "American" type; E, "Atlantic" type; F, "Mogul"; G, "ten-wheeler"; H, "Consolidation."

**Modern Classification.** — The classes shown above, lettered A, B, C, etc., are commonly represented respectively by the symbols 0-4-0; 0-6-0; 0-8-0; 4-4-0; 4-4-2, 2-6-0; 4-6-0; 2-8-0; the first figure being the number of wheels in the truck, the second the driving-wheels, and the third the trailers. Other types are the "Pacific," 4-6-2; the "Prairie," 2-6-2;

and the "Santa Fe," 2-10-2. Engines on the Mallet system, with two locomotive engines under one boiler, are classified 0-8-8-0, 2-6-6-2, etc.

**Formulae for Curves.** (Baldwin Locomotive Works.)

Approximate Formula for Radius.

$$R = 0.7646 W \div 2 P.$$

Approximate Formula for Swing.

$$(T - W) T \div 2 S = R.$$

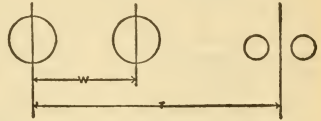
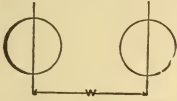

$R$  = radius of min. curve in feet.

$P$  = play of driving-wheels in decimals of 1 ft.

$W$  = rigid wheel-base in feet.

$W$  = rigid wheel-base.

$T$  = total wheel-base.

$R$  = radius of curve.

$S$  = swing on each side of centre.

**Steam-distribution for High-speed Locomotives.**

(C. H. Quereau, *Eng'g News*, March 8, 1894.

**Balanced Valves.** — Mr. Philip Wallis, in 1886, when Engineer of Tests for the C., B. & Q. R. R., reported that while 6 H.P. was required to work unbalanced valves at 40 miles per hour, for the balanced valves 2.2 H.P. only was necessary.

[Later tests were reported by the Master Mechanics' Committee in 1896. Unbalanced valves required from  $\frac{3}{4}$  to  $2\frac{1}{2}$  per cent of the I.H.P. for their motion, balanced valves from  $\frac{1}{3}$  to  $\frac{1}{2}$  as much, and piston valves about  $\frac{1}{5}$  or  $\frac{1}{6}$ . Generally in balanced valves, the area of balance = area of exhaust port + area of two bridges + area of one steam port.]

**Effect of Speed on Average Cylinder-pressure.** — Assume that a locomotive has a train in motion, the reverse lever is placed in the running notch, and the track is level; by what is the maximum speed limited? The resistance of the train and the load increase, and the power of the locomotive decreases with increasing speed till the resistance and power are equal, when the speed becomes uniform. The power of the engine depends on the average pressure in the cylinders. Even though the cut-off and boiler-pressure remain the same, this pressure decreases as the speed increases; because of the higher piston-speed and more rapid valve-travel the steam has a shorter time in which to enter the cylinders at the higher speed. The following table, from indicator-cards taken from a locomotive at varying speeds, shows the decrease of average pressure with increasing speed:

Miles per hour.....	46	51	51	53	54	57	60	66
Speed, revolutions.....	224	248	248	258	263	277	292	321
Average pressure per sq. in.:								
Actual.....	51.5	44.0	47.3	43.0	41.3	42.5	37.3	36.3
Calculated.....	....	46.5	46.5	44.7	43.8	41.6	39.5	35.9

The "average pressure calculated" was figured on the assumption that the mean effective pressure would decrease in the same ratio that the speed increased. The main difference lies in the higher steam-line at the lower speeds, and consequent higher expansion-line, showing that more steam entered the cylinder. The back pressure and compression-lines agree quite closely for all the cards, though they are slightly better for the slower speeds. That the difference is not greater may safely be attributed to the large exhaust-ports, passages, and exhaust tip, which is 5 in. diameter. These are matters of great importance for high speeds.

**Boiler-pressure.** — Assuming that the train resistance increases as the speed after about 20 miles an hour is reached, that an average of 50 lbs. per sq. in. is the greatest that can be realized in the cylinders of a given engine at 40 miles an hour, and that this pressure furnishes just sufficient power to keep the train at this speed, it follows that, to increase the speed to 50 miles, the mean effective pressure must be increased in the same proportion. To increase the capacity for speed of any locomotive its power must be increased, and at least by as much as the speed is to be increased. One way to accomplish this is to increase the boiler-



pressure. That this is generally realized, is shown by the increase in boiler-pressure in the last ten years. For twenty-three single-expansion locomotives described in the railway journals this year the steam-pressures are as follows: 3, 160 lbs.; 4, 165 lbs.; 2, 170 lbs.; 13 180 lbs.; 1, 190 lbs.

*Valve-travel.* — An increased average cylinder-pressure may also be obtained by increasing the valve-travel without raising the boiler-pressure, and better results will be obtained by increasing both. The longer travel gives a higher steam-pressure in the cylinders, a later exhaust-opening, later exhaust-closure, and a larger exhaust-opening — all necessary for high speeds and economy. I believe that a 20-in. port and 6½-in. (or even 7-in.) travel could be successfully used for high-speed engines, and that frequently by so doing the cylinders could be economically reduced and the counter-balance lightened. Or, better still, the diameter of the drivers increased, securing lighter counter-balance and better steam-distribution.

*Size of Drivers.* — Economy will increase with increasing diameter of drivers, provided the work at average speed does not necessitate a cut-off longer than one fourth the stroke. The piston-speed of a locomotive with 62-in. drivers at 55 miles per hour is the same as that of one with 68-in. drivers at 61 miles per hour.

*Steam-ports.* — The length of steam-ports ranges from 15 in. to 23 in., and has considerable influence on the power, speed, and economy of the locomotive. In cards from similar engines the steam-line of the card from the engine with 23-in. ports is considerably nearer boiler-pressure than that of the card from the engine with 17¼-in. ports. That the higher steam-line is due to the greater length of steam-port there is little room for doubt. The 23-in. port produced 531 H.P. in an 18½-in. cylinder at a cost of 23.5 lbs. of water per I.H.P. per hour. The 17¼-in. port, 424 H.P., at the rate of 22.9 lbs. of water, in a 19-in. cylinder.

*Allen Valves.* — There is considerable difference of opinion as to the advantage of the Allen ported-valve. (See *Eng. News*, July 6, 1893.)

A Report on the advantage of Allen valves was made by the Master Mechanics' Committee of 1896.

*Speed of Railway Trains.* — In 1834 the average speed of trains on the Liverpool and Manchester Railway was 20 miles an hour; in 1838 it was 25 miles an hour. But by 1840 there were engines on the Great Western Railway capable of running 50 miles an hour with a train and 80 miles an hour without. (*Trans. A. S. M. E.*, vol. xiii, 363.)

The limitation to the increase of speed of heavy locomotives seems at present to be the difficulty of counterbalancing the reciprocating parts. The unbalanced vertical component of the reciprocating parts causes the pressure of the driver on the rail to vary with every revolution. Whenever the speed is high, it is of considerable magnitude, and its change in direction is so rapid that the resulting effect upon the rail is not inappropriately called a "hammer blow." Heavy rails have been kinked, and bridges have been shaken to their fall under the action of heavily balanced drivers revolving at high speeds. The means by which the evil is to be overcome has not yet been made clear. See paper by W. F. M. Goss, *Trans. A. S. M. E.*, vol. xvi.

Much can be accomplished, however, by carefully designing and proportioning the counter-balance in the wheels and by using light, but strong, reciprocating parts. Pages 41-74 of "Locomotive Operation," gives complete rules and results.

Balanced compound locomotives, with 4 cylinders, the adjacent pistons and crossheads being connected 180° apart have also done much to reduce the disturbance of the moving parts.

Engine No. 999 of the New York Central Railroad ran a mile in 32 seconds equal to 112 miles per hour, May 11, 1893.

$$\left. \begin{array}{l} \text{Speed in} \\ \text{miles per} \\ \text{hour} \end{array} \right\} = \frac{\text{circum. of driving-wheels in in.} \times \text{no. of rev. per min.} \times 60}{63,360}$$

$$= \text{diam., of driving-wheels in in.} \times \text{no. of rev. per min.} \times .003$$

(approximate, giving result  $\frac{8}{10}$  of 1 per cent too great).

*Performance of a High-speed Locomotive.* — The Baldwin compound locomotive No. 1027, on the Phila. & Atlantic City Ry., in 1897 made a record as follows:

For the 52 days the train ran, from July 2d to August 31st, the average time consumed on the run of 55½ miles from Camden to Atlantic City was 48 minutes, equivalent to a uniform rate of speed from start to stop of 69 miles per hour. On July 14th the run from Camden to Atlantic City was made in 46½ min., an average of 71.6 miles per hour for the total distance. On 22 days the train consisted of 5 cars and on 30 days it was made up of 6, the weight of cars being as follows: combination car, 57,200 lbs.; coaches, each, 59,200 lbs.; Pullman car, 85,500 lbs.

The general dimensions of the locomotive are as follows: cylinders, 13 and 22 × 26 in.; height of drivers, 84¼ in.; total wheel-base, 26 ft. 7 in.; driving-wheel base, 7 ft. 3 in.; length of tubes, 13 ft.; diameter of boiler, 58¾ in.; diameter of tubes, 1¾ in.; number of tubes, 278; length of fire-box, 1137/8 in.; width of fire-box, 96 in.; heating-surface of fire-box, 136.4 sq. ft.; heating-surface of tubes, 1614.9 sq. ft.; total heating-surface, 1835.1 sq. ft.; tank capacity, 4000 gallons; boiler-pressure, 200 lbs. per sq. in.; total weight of engine and tender, 227,000 lbs.; weight on drivers (about), 78,600 lbs.

**Fuel Efficiency of American Locomotives.** — Prof. W. M. Goss, as a result of a series of tests run on the Purdue locomotive, finds the disposition of the heat developed by burning coal in a locomotive fire-box to be on the average about as shown in the following table:

Absorbed by steam in the boiler, 52 %; by the superheater, 5 %; total, 57 %. Losses: In vaporizing moisture in the coal, 5 %; discharge of CO., 1 %; high temperature of the products of combustion, 14 %; unconsumed fuel in the form of front-end cinders, 3 %; cinders or sparks passed out of the stack, 9 %; unconsumed fuel in the ash, 4 %; radiation, leakage of steam and water, etc., 7 %. Total losses, 43 %.

It is probable that these losses are considerably less than the losses which are experienced in the average locomotive in regular railway service. — (Bulletin No. 402, U.S. Geol. Survey, 1909.)

**Locomotive Link Motion.** — Mr. F. A. Halsey, in his work on "Locomotive Link Motion," 1898, shows that the location of the eccentric-rod pins back of the link-arc and the angular vibrations of the eccentric-rods introduce two errors in the motion which are corrected by the angular vibration of the connecting-rod and by locating the saddle-stud back of the link-arc. He holds that it is probable that the opinions of the critics of the locomotive link motion are mistaken ones, and that it comes little short of all that can be desired for a locomotive valve motion. The increase of lead from full to mid gear and the heavy compression at mid gear are both advantages and not defects. The cylinder problem of a locomotive is entirely different from that of a stationary engine. With the latter the problem is to determine the size of the cylinder and the distribution of steam to drive economically a given load at a given speed. With locomotives the cylinder is made of a size which will start the heaviest train which the adhesion of the locomotive will permit, and the problem then is to utilize that cylinder to the best advantage at a greatly increased speed, but under a greatly reduced mean effective pressure.

Negative lead at full gear has been used in the recent practice of some railroads. The advantages claimed are an increase in the power of the engine at full gear, since positive lead offers resistance to the motion of the piston; easier riding; reduced frequency of hot bearings; and a slight gain in fuel economy. Mr. Halsey gives the practice as to lead on several roads as follows, showing great diversity:

	Full Gear Forward, in.	Full Gear Back, in.	Reversing Gear, in.
New York, New Haven & Hartford .....	1/16 pos.	1/4 neg.	1/4 pos.
Maine Central .....	0	1/4 neg.	.....
Illinois Central .....	1/32 pos.	.....	abt 3/16
Lake Shore.....	1/16 neg.	9/64 neg.	5/16 pos.
Chicago Great Western.....	0	0	3/16 to 9/16
Chicago & Northwestern ..	3/16 neg.	.....	1/4 pos.

### DIMENSIONS OF SOME LARGE AMERICAN LOCOMOTIVES, 1893 AND 1904.

Of the four locomotives described in the table on the next page the first two were exhibited at the Chicago Exposition in 1893. The dimensions are from *Engineering News*, June, 1893. The first, or Decapod engine, has ten-coupled driving-wheels. It is one of the heaviest and most powerful engines built up to that date for freight service. The second is a simple engine, of the standard American 8-wheel type, 4 driving-wheels, and a 4-wheel truck in front. This engine held the world's record for speed in 1893 for short distances, having run a mile in 32 seconds.

The other two engines formed part of the exhibit of the Baldwin Locomotive Works at the St. Louis Exposition in 1904. The Santa Fe type engine has five pairs of driving-wheels, and a two-wheeled truck at the front and at the rear. It is equipped with Vauclain tandem compound cylinders.

#### Dimensions of Some American Locomotives.

(Baldwin Loco. Wks. 1904-8.)

Reference Number.	Steam Pressure.	Boilers.		Tubes.			Heating Surface.		Driving Wheels	Weight, lbs.	
		Diam., ins.	Grate, sq. ft.	No.	Diam., ins.	Length, ft. in.	Fire box, sq. ft.	Tubes, sq. ft.		Diam., ins.	on Drivers
1	150	42	9	97	2	11 7	41	586	37	44,420	52,720
2	160	50	14.6	160	2	10 6	75	873	48	72,150	84,650
3	200	60	25.9	287	2	11 7	133	1733	69	83,680	124,420
4	200	62	30	272	2	16 1	136	2279	68	112,000	159,000
5	200	76	37.2	298	2 1/4	13 10	200	2414	51	164,000	179,500
6	200	68	35	306	2 1/4	14 6	195	2593	56	166,000	186,000
7	200	66	49.5	273	2 1/4	18 10	190	3015	79	101,420	193,760
8	200	70	53.5	318	2 1/4	19	195	3543	79	144,600	209,210
9	210	70	55	303	2 1/4	21	190	3772	74	151,290	230,940
10	225	78	58.5	463	2 1/4	19	210	5155	57	237,800	267,800
11	200	84	68.4	401	2 1/4	21	232	4941	57	394,150	425,900

Type and cylinder size: 1, Mogul, 13 × 18; 2, Mogul, 16 × 20; 3, American, 18 × 24; 4, 10-wheel balanced compound, 16 × 26 and 26 × 28; 5, Consolidation, 22 × 28; 6, Consolidation, 23 and 35 × 32; 7, Atlantic, 15 and 25 × 26; 8, Prairie, 17 and 28 × 28; 9, Pacific, 22 × 28; 10, Decapod, 19 and 32 × 32; 11, Mallet, two each 26 and 40 × 30.

**The Mallet Compound Locomotive.**—The Mallet articulated locomotive consists principally of two sets of engines flexibly connected under one boiler; the rear, which is a high-pressure engine of two cylinders, fixed rigid with the boiler and receiving the steam direct from the dome. The front or low-pressure engine, also provided with two cylinders, is capable of lateral movement to adjust itself to the curvature of the road on the same general principle as a radial truck. The high-pressure engine exhausts into a receiver flexibly connecting the cylinders of the two sets of engines, from which the low-pressure engine receives its steam supply and is exhausted from the latter through a flexible pipe to the stack. Each cylinder has its independent valve and gear connected to and operated with a common reversing rigging. By this means the tractive power can be doubled over that of the ordinary engine for a given weight of rail with a substantial saving in fuel. (See paper by C. J. Mellin, *Trans. A. S. M. E.*, 1909.)

This type of locomotive is adapted to a wider range of service than perhaps any other design. It was originally intended for narrow-gage roads of light construction, necessitating sharp curves and steep grades, in combination with light rails. The characteristics of this design are flexibility and uniform distribution of weight combined with the use of two separate engines which would not slip at the same time, and the total weight carried on the drivers, giving great tractive power. The first engine of this class





was built about 1887, and in 1909 there were approximately 500 running in Europe. They are now extensively in use in the United States for the heaviest service. The largest locomotive yet built is described in *Eng. News*, April 29, 1909. It was built by the Baldwin Locomotive Works for use on the heavy grades of the Southern Pacific R.R. The principal dimensions are as follows: Cylinders, 26 and 40 × 30 ins.; valves, balanced piston; boiler (steel): diameter, 84 ins.; thickness,  $\frac{13}{16}$  and  $\frac{27}{32}$  ins.; working pressure, 200 lbs. per sq. in.; fuel, oil; fire-tubes, 401,  $2\frac{1}{4}$  ins. dia. × 21 ft.; firebox: length, 126 ins., width,  $78\frac{1}{4}$  ins., depth, front,  $75\frac{1}{2}$  ins., depth, back,  $70\frac{1}{2}$  ins.; water spaces, 5 ins.; grate area, 68.4 sq. ft.; feed-water heater: length, 63 ins., tubes, 401,  $2\frac{1}{4}$  ins. dia.; heating surface: firebox, 232 sq. ft., fire-tubes, 4941 sq. ft., feed-water heater tubes, 1220 sq. ft.; smokebox superheater, 655 sq. ft.; wheels: driving (16), 57 ins. O. dia., main journals, 11 × 12 ins., other journals, 10 × 12 ins. truck (4),  $30\frac{1}{2}$  ins. dia., journals, 6 × 10 ins.; tender (8),  $33\frac{1}{2}$  ins. dia., journals, 6 × 11 ins.; wheelbase: driving, 39 ft. 4 ins., rigid, 15 ft., total engine, 56 ft. 7 ins., total engine and tender, 83 ft. 6 ins.; length over all, 93 ft.  $6\frac{1}{2}$  ins.; weight: on drivers, 394,150 lbs., on front truck, 14,500 lbs., on back truck, 17,250 lbs., total engine 425,900 lbs., total engine and tender 596,000 lbs.; tender: water tank capy., 9000 gals., oil tank capy., 2850 gals.

### Indicated Water Consumption of Single and Compound Locomotive Engines at Varying Speeds.

C. H. Quereau, *Eng'g News*, March 8, 1894.

Two-cylinder Compound.			Single-expansion.		
Revolutions.	Speed, miles per hour.	Water per I.H.P. per hour.	Revolutions.	Miles per Hour.	Water.
100 to 150	21 to 31	18.33 lbs.	151	31	21.70
150 to 200	31 to 41	18.9 lbs.	219	45	20.91
200 to 250	41 to 51	19.7 lbs.	253	52	20.52
250 to 275	51 to 56	21.4 lbs.	307	63	20.23
			321	66	20.01

It appears that the compound engine is the more economical at low speeds, the economy decreasing as the speed increases, and that the simple engine increases in economy with increase of speed within ordinary limits, becoming more economical than the compound at speeds of more than 50 miles per hour.

The C., B. & Q. two-cylinder compound, which was about 30% less economical than simple engines of the same class when tested in passenger service, has since been shown to be 15% more economical in freight service than the best single-expansion engine, and 29% more economical than the average record of 40 simple engines of the same class on the same division.

The water rate is also affected by the cut-off; the following table gives what we should consider *very good* results in practice, though better (i.e. lower results) have occasionally been obtained. (G. R. Henderson, 1906.)

Cut-off per cent of stroke . . . . .	10	20	30	40	50
Lbs. water per I.H.P. hour — simple . .	26	23	22	22	23
Lbs. water per I.H.P. hour — compound . .	..	..	18	18	18
Cut-off per cent of stroke . . . . .	60	70	80	90	100
Lbs. water per I.H.P. hour — simple . .	24	26	29	33	38
Lbs. water per I.H.P. hour — compound	18 $\frac{1}{2}$	19 $\frac{1}{2}$	20 $\frac{1}{2}$	22 $\frac{1}{2}$	25

**Indicator-tests of a Locomotive at High Speed.** (*Locomotive Eng'g*, June, 1893.) — Cards were taken by Mr. Angus Sinclair on the locomotive drawing the Empire State Express.

RESULTS OF INDICATOR-DIAGRAMS.

Card No.	Revs.	Miles per hour.	I.H.P.	Card No.	Revs.	Miles per hour.	I.H.P.
1	160	37.1	648	7	304	70.5	977
2	260	60.8	728	8	296	68.6	972
3	190	44	551	9	300	69.6	1,045
4	250	58	891	10	304	70.5	1,059
5	260	60	960	11	340	78.9	1,120
6	298	69	983	12	310	71.9	1,026

The locomotive was of the eight-wheel type, built by the Schenectady Locomotive Works, with 19 × 24 in. cylinders, 78-in. drivers, and a large boiler and fire-box. Details of important dimensions are as follows: Heating-surface of fire-box, 150.8 sq. ft.; of tubes, 1670.7 sq. ft.; of boiler, 1821.5 sq. ft. Grate area, 27.3 sq. ft. Fire-box: length, 8 ft.; width, 3 ft. 4 7/8 in. Tubes, 268; outside diameter, 2 in. Ports: steam, 18 × 1 1/4 in.; exhaust, 18 × 2 3/4 in. Valve-travel, 5 1/2 in. Outside lap, 1 in.; inside lap, 1/64 in. Journals: driving-axle, 8 1/2 × 10 1/2 in.; truck-axle, 6 × 10 in.

The train consisted of four coaches, weighing, with estimated load, 340,000 lbs. The locomotive and tender weighed in working order 200,000 lbs., making the total weight of the train about 270 tons. During the time that the engine was first lifting the train into speed diagram No. 1 was taken. It shows a mean cylinder-pressure of 59 lbs. According to this, the power exerted on the rails to move the train is 6553 lbs., or 24 lbs. per ton. The speed is 37 miles an hour. When a speed of nearly 60 miles an hour is reached the average cylinder-pressure is 40.7 lbs., representing a total traction force of 4520 lbs., without making deductions for internal friction. If we deduct 10% for friction, it leaves 15 lbs. per ton to keep the train going at the speed named. Cards 6, 7, and 8 represent the work of keeping the train running 70 miles an hour. They were taken three miles apart, when the speed was almost uniform. The average cylinder-pressure for the three cards is 47.6 lbs. Deducting 10% again for friction, this leaves 17.6 lbs. per ton as the power exerted in keeping the train up to a velocity of 70 miles. Throughout the trip 7 lbs. of water were evaporated per lb. of coal. The work of pulling the train from New York to Albany was done on a coal consumption of about 3 1/8 lbs. per H. P. per hour. The highest power recorded was at the rate of 1120 H.P.

**Locomotive-testing Apparatus at the Laboratory of Purdue University.** (W. F. M. Goss, *Trans. A. S. M. E.*, vol. xiv, 826.)—The locomotive is mounted with its drivers upon supporting wheels which are carried by shafts turning in fixed bearings, thus allowing the engine to be run without changing its position as a whole. Load is supplied by four friction-brakes fitted to the supporting shafts and offering resistance to the turning of the supporting wheels. Traction is measured by a dynamometer attached to the draw-bar. The boiler is fired in the usual way, and an exhaust-blower above the engine, but not in pipe connection with it, carries off all that may be given out at the stack.

A *Standard Method of Conducting Locomotive-tests* is given in a report by a Committee of the A.S.M.E. in vol. xiv of the *Transactions*, page 1312

**Locomotive Tests of the Penna. R. R. Co.**—Eight locomotives were tested in the dynamometer testing plant built by the P. R. R. Co. at the St. Louis Exhibition in 1903. Among the principal results obtained and conclusions derived are the following:

BOILER PERFORMANCE.

Coal per sq. ft. grate per hour.	lbs.						
	20	40	60	80	100	120	
Equiv. evap. per sq. ft. H. S. per hour							
	3-5	5-7.5	7-10	8.2-12	10.4-14	11.4-15.3	
Coal per sq. ft. H. S. per hour							
	0.6	0.8	1.0	1.2	1.4	1.6	1.8
Equiv. evap. per lb. dry coal							
	10-11.5	9-10.5	8.2-9.7	7.7-9.1	7.1-8.5	6.6-8.1	6.2-7.7
Equiv. evap. per sq. ft. H. S. per hour							
	4	6	8	10	12	14	
Equiv. evap. per lb. dry coal							
	9.7-12.1	8.8-11.3	7.8-10.5	6.8-9.6	5.8-8.8	5.5-8	



The coal used in these tests was a semi-bituminous, containing 16.25% volatile combustible, 7.00% ash and 0.90% moisture.

The maximum boiler capacity ranged from 8½ to more than 16 lbs. of water evaporated per hour per sq. ft. of heating surface. Little or no advantage was found in the use of Serve or ribbed tubes.

The boiler efficiency decreases as the rate of power developed increases.

Furnace losses due to excess air are no greater with large grates properly fired than with smaller ones. The boilers with small grates were inferior in capacity to those with large grates.

No special advantage is derived from large fire-box heating surface; the tube heating surface is effective in absorbing heat not taken up by the fire-box.

#### ENGINE PERFORMANCE.

Maximum I.H.P., four freight locomotives, 1041, 1050, 1098, 1258  
Maximum I.H.P., four passenger locomotives, 816, 945, 1622, 1641

	Kind of Locomotive.		
	Simple Freight.	Compound Freight.	Compound Passenger.
Minimum water per I.H.P. hour.....	23.67	20.26	18.86
Water per I.H.P. hr. at maximum load .....	23.83	22.03	21.39
Water per I.H.P. hr. at max. consumption...	28.95	25.31	24.41

The steam consumption of simple locomotives operating at all speeds and cut-offs commonly employed on the road falls between the limits of 23.4 and 28.3 lbs. per I.H.P. hour; compound locomotives between 18.6 and 27 lbs.; and with superheating the minimum steam consumption was reduced to 16.6 lbs. of superheated steam.

Comparing a simple and a compound locomotive, the simple engine used 40% more steam than the compound at 40 revs. per min., 27% more at 80 revs., and only 7% more at 160 revs. per min.

The frictional resistance of the engines showed an extreme variation ranging from 6 to 38% of the indicated horse-power. The frictional losses increased rapidly at speeds in excess of 160 revs. per min. It appears that the matter of machine friction is closely related to that of lubrication. With oil lubrication a stress at the draw-bar of approximately 500 lbs. is required to overcome the friction of each coupled axle, while with grease the required force is from 800 to 1100 lbs.

The lowest figures for dry coal consumed per dynamometer H.P. hour were approximately as follows:

Revs. per min. ....	40	80	160	240
Compound freight engine, { lbs. coal	2.10	2.25	3.25	....
{ D.H.P.	500	800	800	....
Compound passenger engine, { lbs. coal	....	2.8	2.3	3.0
{ D.H.P.	....	600	900	1000

A complete report of the St. Louis locomotive tests is contained in a book of 734 pages and over 800 illustrations, published by the Penna. R.R. Co., Philadelphia, 1906. See also pamphlet on Locomotive Tests, published by Amer. Locomotive Co., New York, 1906, and *Trans. A. S. M. E.*, xxvii, 610.

#### Weights and Prices of Locomotives, 1885 and 1905. (Baldwin Loco. Wks.)

	1885				1905			
	Type.	W'ght	Price		Type.	W'ght	Price	
	American....	80,857	\$6,695	\$ 0828	American.....	102,000	\$9,410	\$.092
	Mogul.....	72,800	6,662	.0912	Atlantic.....	187,200	15,750	.083
	Ten wheel...	85,000	7,583	.0892	Pacific.....	227,000	15,830	.070
	Consolidation	92,400	7,888	.0854	Ten wheel.....	156,000	13,690	.088
					Consolidation .	192,460	14,500	.075

The price per pound is figured from the weight of the engine in working order, without the tender.

**Depreciation of Locomotives.**—(Baldwin Loco. Wks.)—It is suggested that for the first five years the full second-hand value of the locomotive (75% of first cost) be taken; for the second five years 85% of this value; for the third five years, 70%; after 15 years, 50% of the second-hand value; and after 20 years, and as long as the engine remains in use, 25% of the first cost.

**The Average Train Loads** of 14 railroads increased from 229 tons of 2000 lbs. in 1895 to 385 tons in 1904. On the Chicago, Milwaukee & St. Paul Ry. the average load increased from 152 tons in 1895 to 281 tons in 1903, and on the Lake Shore & Michigan Southern Ry. from 318 tons in 1895 to 615 tons in 1903. In the same time the average cost of transportation per ton mile on the C., M. & St. P. Ry. decreased from 0.67 to 0.58 cent; and on the L. S. & M. S. Ry. increased from 0.39 to 0.41 cent, the decrease in cost due to heavier train loads being offset by higher cost for labor and material.

**Tractive Force of Locomotives, 1893 and 1905.**  
(Baldwin Loco. Wks.)

Passenger, 1893.	Weight on Driver.	Tractive Force.	Passenger, 1905.	Weight on Driver.	Tractive Force.
American, single-ex.	75,210	17,270	Atlantic, comp. ....	101,420	22,180
American, comp. ....	83,860	12,900	Atlantic, single-ex. . .	103,600	23,800
American, single-ex. . .	64,560	15,550	Pacific, single-ex. . . .	141,290	29,910
American, comp. ....	78,480	14,050	Pacific, single-ex. . . .	114,890	25,610
Ten-wheel type, com.	93,850	16,480	Atlantic, single-ex. . .	80,930	21,740
Average. ....	.....	15,250	.....	.....	24,648
Freight, 1893.			Freight, 1905.		
Consolidation, comp.	120,600	21,190	Sante Fe type, comp.	234,580	62,740
Ten-wheel, s'gle-ex..	101,000	23,310	Consol., 2-cyl. comp..	166,000	40,200
Mogul, single-ex. ....	91,340	21,030	Consol., single-ex. ....	151,490	40,150
Decapod, compound	172,000	35,580	Consol., single-ex. ....	171,560	44,080
			Consol., single-ex. ....	165,770	45,170
Average. ....	.....	25,277	.....	.....	46,468

**Waste of Fuel in Locomotives.**—In American practice economy of fuel is necessarily sacrificed to obtain greater economy due to heavy train-loads. D. L. Barnes, in *Eng. Mag.*, June, 1894, gives a diagram showing the reduction of efficiency of boilers due to high rates of combustion, from which the following figures are taken:

Lbs. of coal per sq. ft. of grate per hour ...	12	40	80	120	160	200
Per cent efficiency of boiler. ....	80	75	67	59	51	43

A rate of 12 lbs. is given as representing stationary-boiler practice, 40 lbs. English locomotive practice, 120 lbs. average American, and 200 lbs. maximum American, locomotive practice.

Pages 473 and 475 of Henderson's "Locomotive Operation" give diagrams of evaporation per lb. of various kinds of coal for different rates of combustion per sq. ft. grate area and heating surface.

**Advantages of Compounding.**—Report of a Committee of the American Railway Master Mechanics' Association on Compound Locomotives (*Am. Mach.*, July 3, 1890) gives the following summary of the advantages gained by compounding: (a) It has achieved a saving in the fuel burnt averaging 18% at reasonable boiler-pressures, with encouraging possibilities of further improvement in pressure and in fuel and water economy. (b) It has lessened the amount of water (dead weight) to be

hauled, so that (c) the tender and its load are materially reduced in weight. (d) It has increased the possibilities of speed far beyond 60 miles per hour, without unduly straining the motion, frames, axles, or axle-boxes of the engine. (e) It has increased the haulage-power at full speed, or, in other words, has increased the continuous H.P. developed, per given weight of engine and boiler. (f) In some classes has increased the starting-power. (g) It has materially lessened the slide-valve friction per H.P. developed. (h) It has equalized or distributed the turning force on the crank-pin, over a longer portion of its path, which, of course, tends to lengthen the repair life of the engine. (i) In the two-cylinder type it has decreased the oil consumption, and has even done so in the Woolf four-cylinder engine. (j) Its smoother and steadier draught on the fire is favorable to the combustion of all kinds of soft coal; and the sparks thrown being smaller and less in number, it lessens the risk to property from destruction by fire. (k) These advantages and economies are gained without having to improve the man handling the engine, less being left to his discretion (or careless indifference) than in the simple engine. (l) Valve-motion, of every locomotive type, can be used in its best working and most effective position. (m) A wider elasticity in locomotive design is permitted; as, if desired, side-rods can be dispensed with or articulated engines of 100 tons weight, with independent trucks, used for sharp curves on mountain service, as suggested by Mallet and Brunner.

Of 27 compound locomotives in use on the Phila. and Reading Railroad (in 1892), 12 are in use on heavy mountain grades, and are designed to be the equivalent of 22 X 24 in. simple consolidations; 10 are in somewhat lighter service and correspond to 20 X 24 in. consolidations; 5 are in fast passenger service. The monthly coal record shows:

Class of Engine.	No.	Gain in Fuel Economy.
Mountain locomotives.....	12	25% to 30%
Heavy freight service.....	10	12% to 17%
Fast passenger.....	5	9% to 11%

(Report of Com. A. R. M. M. Assn. 1892.) For a description of the various types of compound locomotive, with discussion of their relative merits, see paper by A. Von Borries, of Germany, the Development of the Compound Locomotive, *Trans. A. S. M. E.*, 1893, vol. xiv, p. 1172.

As a rule compounds cost considerably more for repairs, and require a better class of engineers and machinists to obtain satisfactory results. (Henderson.)

**Balanced Compound Locomotives.**—There are two high-pressure cylinders placed between the frames and two low-pressure cylinders outside. The inside crank shaft has cranks 90° apart, and each outside crank pin is 180° from the inside crank pin on the same side, so that the engine on each side is perfectly balanced. The balanced piston valve is so made that high-pressure steam may be admitted to the low-pressure cylinder for starting. See circular of the Baldwin Loco. Wks., No. 62, 1907.

**Superheating in Locomotives.** (*R. R. Age Gazette*, Nov. 20, 1908.)—Superheating steam in locomotives has been found to effect a saving of 10 to 15% in the fuel consumption of a locomotive, and 8 to 12% of the water used, or with the same fuel to increase the horse-power and the tractive force. The Baldwin Locomotive Works builds a superheater in the smoke-box, where it utilizes part of the heat of the waste gases in drying the steam and superheating it 50 to 100° F. The heating surface of the superheater is from 12 to 22% of the heating surface in the tubes and fire-box of the boiler. It is recommended to use a boiler pressure of about 160 lbs. when a superheater is used, and to have cylinders of larger dimensions than when ordinary steam of 200 lbs. pressure is used. For an illustrated and historical description of the use of superheating in locomotives, see paper by H. H. Vaughan, read before the Am. Ry. Mast. Mechs.' Assn., *Eng. News*, June 22, 1905.

**Counterbalancing Locomotives.**—Rules for counterbalancing, adopted by different locomotive-builders, are quoted in a paper by Prof. Lanza (*Trans. A. S. M. E.*, x, 302.) See also articles on Counterbalancing Locomotives, in *R. R. & Eng. Jour.*, March and April, 1890; *Trans. A. S. M. E.*, vol. xvi, 305; and *Trans. Am. Ry. Master Mechanics' Assn.*



1897. W. E. Dalby's book on the "Balancing of Engines" (Longmans, Green & Co., 1902) contains a very full discussion of this subject. See also Henderson's "Locomotive Operation" (*The Railway Age*, 1904).

**Narrow-gauge Railways in Manufacturing Works.** — A tramway of 18 inches gauge, several miles in length, is in the works of the Lancashire and Yorkshire Railway. Curves of 13 feet radius are used. The locomotives used have the following dimensions (*Proc. Inst. M. E.*, July, 1888): The cylinders are 5 in. in diameter with 6 in. stroke, and 2 ft. 3 $\frac{1}{4}$  in. centre to centre. Wheels 16 $\frac{1}{4}$  in. diameter, the wheel-base 2 ft. 9 in.; the frame 7 ft. 4 $\frac{1}{4}$  in. long, and the extreme width of the engine 3 feet. Boiler, of steel, 2 ft. 3 in. outside diam. and 2 ft. long between tube-plates, containing 55 tubes of 1 $\frac{3}{8}$  in. outside diam.; fire-box, of iron and cylindrical, 2 ft. 3 in. long and 17 in. inside diam. Heating-surface 10.42 sq. ft. in the fire-box and 36.12 in the tubes, total 46.54 sq. ft.; grate-area, 1.78 sq. ft.; capacity of tank, 26 $\frac{1}{2}$  gallons; working-pressure, 170 lbs. per sq. in. tractive power, say, 1412 lbs., or 9.22 lbs. per lb. of effective pressure per sq. in., on the piston. Weight, empty, 2.80 tons; full and in working order, 3.19 tons.

For description of a system of narrow-gauge railways for manufactories, see circular of the C. W. Hunt Co., New York.

**Light Locomotives.** — For dimensions of light locomotives used for mining, etc., and for much valuable information concerning them, see catalogue of H. K. Porter Co., Pittsburgh.

**Petroleum-burning Locomotives.** (From Clark's Steam-engine.) — The combustion of petroleum refuse in locomotives has been successfully practised by Mr. Thos. Urquhart, on the Grazi and Tsaritsin Railway, Southeast Russia. Since November, 1884, the whole stock of 143 locomotives under his superintendence has been fired with petroleum refuse. The oil is injected from a nozzle through a tubular opening in the back of the fire-box, by means of a jet of steam, with an induced current of air.

A brickwork cavity or "regenerative or accumulative combustion-chamber" is formed in the fire-box, into which the combined current breaks as spray against the rugged brickwork slope. In this arrangement the brickwork is maintained at a white heat, and combustion is complete and smokeless. The form, mass, and dimensions of the brickwork are the most important elements in such a combination.

Compressed air was tried instead of steam for injection, but no appreciable reduction in consumption of fuel was noticed.

The heating-power of petroleum refuse is given as 19,832 heat-units, equivalent to the evaporation of 20.53 lbs. of water from and at 212° F., or to 17.1 lbs. at 8 $\frac{1}{2}$  atmospheres, or 125 lbs. per sq. in., effective pressure. The highest evaporative duty was 14 lbs. of water under 8 $\frac{1}{2}$  atmospheres per lb. of the fuel, or nearly 82% efficiency.

There is no probability of any extensive use of petroleum as fuel for locomotives in the United States, on account of the unlimited supply of coal and the comparatively limited supply of petroleum. Texas and California oils are now (1902) used in locomotives of the Southern Pacific Railway and the Santa Fé System.

**Self-propelled Railway Cars.** — The use of single railway cars containing a steam or gasolene motor has become quite common in Europe. For a description of different systems see a paper on European Railway Motor Cars by B. D. Gray in *Trans. A. S. M. E.*, 1907.

**Fireless Locomotive.** — The principle of the Francq locomotive is that it depends for the supply of steam on its spontaneous generation from a body of heated water in a reservoir. As steam is generated and drawn off the pressure falls; but by providing a sufficiently large volume of water heated to a high temperature, at a pressure correspondingly high, a margin of surplus pressure may be secured, and means may thus be provided for supplying the required quantity of steam for the trip.

The fireless locomotive designed for the service of the Metropolitan Railway of Paris has a cylindrical reservoir having segmental ends, about 5 ft. 7 in. in diameter, 26 $\frac{1}{4}$  ft. in length, with a capacity of about 620 cubic feet. Four-fifths of the capacity is occupied by water, which is heated by the aid of a powerful jet of steam supplied from stationary boilers. The water is heated until equilibrium is established between the boilers and the reservoir. The temperature is raised to about 390° F., corresponding to 225 lbs. per sq. in. The steam from the reservoir is

passed through a reducing-valve, by which the steam is reduced to the required pressure. It is then passed through a tubular superheater situated within the receiver at the upper part, and thence through the ordinary regulator to the cylinders. The exhaust-steam is expanded to a low pressure, in order to obviate noise of escape. In certain cases the exhaust-steam is condensed in closed vessels, which are only in part filled with water.

In working off the steam from a pressure of 225 lbs. to 67 lbs., 530 cubic feet of water at 390° F. is sufficient for the traction of the trains, for working the circulating-pump for the condensers, for the brakes, and for electric-lighting of the train. At the stations the locomotive takes from 2200 to 3300 lbs. of steam — nearly the same as the weight of steam consumed during the run between two consecutive charging stations. There is 210 cubic feet of condensing water. Taking the initial temperature at 60° F., the temperature rises to about 180° F. after the longest runs underground.

The locomotive has ten wheels, on a base 24 ft long, of which six are coupled, 4½ ft. in diameter. The extreme wheels are on radial axles. The cylinders are 23½ in. in diameter, with a stroke of 23½ in.

The engine weighs, in working order, 53 tons, of which 36 tons are on the coupled wheels. The speed varies from 15 miles to 25 miles per hour. The trains weigh about 140 tons.

**Compressed-air Locomotives.** — A compressed-air locomotive consists essentially of a storage tank mounted upon driving wheels, with two engines similar to those of a steam locomotive. One or more reservoirs or storage tanks are located on the line, from which the locomotive tank is charged. These reservoirs are usually riveted steel cylinders, designed for about 1000 lbs. working pressure; but sometimes seamless steel cylinders of small diameter, designed for a working pressure of 2000 lbs. or upwards, are used. The customary maximum pressure in the locomotive tank is 800 lbs. gauge, and the working pressure in the cylinders is from 130 to 140 lbs. The following table is condensed from one in a circular of the Baldwin Locomotive Works, No. 46, 1904.

See account of the Mekarski compressed-air locomotives, page 652 *ante*.

**DIMENSIONS AND TRACTIVE POWER OF FOUR COUPLED COMPRESSED-AIR LOCOMOTIVES HAVING TWO STORAGE TANKS.**

Class.....	4-4-C	4-6-C	4-8-C	4-10-C	4-12-C	4-16-C	4-18-C
Cylinders, inches....	5×10	6×10	7×12	8×14	9×14	11×14	12×16
Diam. of drivers.....	22"	24"	24"	26"	28"	28"	30"
Wheel base.....	4' 0"	4' 3"	4' 5"	5' 3"	5' 5"	5' 6"	6' 0"
Approx. weight, lbs..	10,000	14,000	18,000	23,000	27,000	37,000	44,000
Inside dia. of tanks..	26"	28"	30"	32"	34"	38"	40"
Aggregate tank vol., cu. ft.....	75	100	130	170	200	280	320
App. height.....	4' 5"	4' 10"	5' 0"	5' 4"	5' 8"	6' 0"	6' 4"
App. width over tanks.....	4' 10"	5' 2"	5' 6"	5' 10"	6' 3"	7' 0"	7' 4"
App. width over cyl- inders.....	Gauge +24"	Gauge +26"	Gauge +27"	Gauge +28"	Gauge +30"	Gauge +32"	Gauge +33"
App. length over bumpers.....	12' 0"	14' 0"	15' 0"	17' 0"	18' 0"	20' 0"	20' 6"
Tractive Power Full stroke.....	1350	1785	2915	4100	4820	7200	9140
3/4 Stroke cut-off	1290	1700	2780	3900	4580	6860	8705
1/2 Stroke cut-off	940	1240	2025	2840	3345	4995	6340
1/4 Stroke cut-off	510	670	1100	1540	1815	2710	3440

Draw-bar pull on any grade = tractive power - (.0075 + % of grade) × weight of engine.

Working pressure in cylinders 140 lbs.; tank storage pressure, 800 lbs.

Other sizes of engines are 5½ × 10 in., 6 × 12 in., and 8 × 12 in., 24-in. diam. of drivers; 9 × 14 in., 26-in. drivers, and 10 × 14 in., 28-in. drivers.

CUBIC FEET OF AIR, AT DIFFERENT STORAGE PRESSURES, REQUIRED TO HAUL ONE TON ONE MILE AT HALF STROKE CUT-OFF, WITH 20, 30 AND 40 LBS. FRICTIONAL RESISTANCE PER TON. (Baldwin Loco. Wks.)

Storage pressure	600	700	800	.....	600	700	800	.....	600	700	800	
Cylinder working pressure.....	130	135	140	.....	130	135	140	.....	130	135	140	
Grade.	R	V	V	V	R	V	V	V	R	V	V	V
Level.....	20.0	1.16	0.99	0.87	30.0	1.74	1.50	1.31	40.0	2.33	1.99	1.74
1/2 %.....	31.2	1.81	1.56	1.36	41.2	2.40	2.05	1.79	51.2	2.98	2.56	2.23
1 %.....	42.4	2.47	2.12	1.85	52.4	3.05	2.61	2.28	62.4	3.64	3.11	2.73
2 %.....	64.8	3.78	3.24	2.83	74.8	4.35	3.73	3.26	84.8	4.94	4.24	3.70
3 %.....	87.2	5.08	4.35	3.81	97.2	5.67	4.86	4.25	107.2	6.25	5.35	4.69
4 %.....	109.6	6.39	5.48	4.79	119.6	6.97	5.97	5.22	129.6	7.56	6.47	5.67
5 %.....	132.0	7.69	6.60	5.77	142.0	8.27	7.09	6.20	152.0	8.86	7.60	6.64

R=resistance per ton of 2240 lbs. in pounds. V=cubic feet of air.

*Air Locomotives with Compound Cylinders and Atmospheric Interheaters* are built by H. K. Porter Co. The air enters the high-pressure cylinder at 250 lbs. gauge pressure and is expanded down to 50 lbs., overcoming resistance, while the temperature drops about 140° F. This loss of heat is practically all restored in the atmospheric interheater, which is a cylindrical reservoir filled with brass tubes located in the passage-way from the high- to the low-pressure cylinder. The air enters the low-pressure cylinder at 50 lbs. gauge and a temperature within 10 or 20° of that of the surrounding atmosphere. The exhaust is used to induce a draught of atmospheric air through the tubes of the interheater. This combination permits of expanding the air from 250 lbs. down to atmosphere without unmanageable refrigeration.

The following calculation shows the relative economy of a single-cylinder locomotive using air at 150 lbs. and of a compound using air at 250 lbs. in the high-pressure and 50 lbs. in the low-pressure cylinder, non-expansive working being assumed in both cases.

11.2 cu. ft. of free air at 150 lbs. gauge and atmospheric temperature would fill a cylinder of 1 cu. ft. capacity, and in moving a piston of 1 sq. ft. area one foot would develop  $144 \times 150 = 21,600$  ft. lbs. of energy.

11.2 cu. ft. of free air at 250 lbs. gauge if used in a cylinder 0.623 sq. ft. area and 1 ft. stroke would develop  $0.623 \times 144 \times 250 = 22,425$  ft. lbs.

If expanded in two cylinders with a ratio of 4 to 1 the energy developed would be  $0.623 \times 144 \times 200$  plus  $4 \times 0.623 \times 144 \times 50 = 35,880$  ft. lbs., if the heat is restored between the two cylinders. Gain by compounding with interheating, over simple cylinders with 150 lbs. initial pressure,  $35,880 \div 21,600 = 1.66$ .

These results are about the best that can be obtained with either simple or compound locomotives, as any improvement due to expansive working just about balances the losses due to clearance and initial refrigeration. The work done per cubic foot of free air in the two systems is: with simple cylinders,  $21,600 \div 11.2 = 1840$  ft. lbs.; with compound cylinders and atmospheric interheater,  $35,880 \div 11.2 = 3205$  ft. lbs.

The above calculations have been practically confirmed by actual tests, which show 1900 ft. lbs. of work per cubic foot of free air with the simple locomotive and 3000 ft. lbs. with the compound, the gain due to expansive working and the losses due to internal friction being somewhat greater in the compound than in the simple machine.

In the operation of compressed-air locomotives the air compressor is generally delivering compressed air at a pressure fluctuating between 800 and 1000 lbs. per sq. in. into the storage reservoir, and it requires an average of about 12,000 ft. lbs. per cubic foot of free air to compress and deliver it at these pressures. The efficiency of the two systems then is:  $1900 \div 12000 = 16\%$  for the simple locomotive, and  $3000 \div 12000 = 25\%$  for the compound with atmospheric interheater.



SHAFTING.

(See also TORSIONAL STRENGTH; also SHAFTS OF STEAM ENGINES.)

For shafts subjected to torsion only, let  $d$  = diam. of the shaft in ins.,  $P$  = a force in lbs. applied on a lever arm at a distance =  $a$  ins. from the axis,  $S$  = shearing resistance at the outer fiber, in lbs. per sq. in., then

$$Pa = \frac{\pi d^3 S}{16} = \frac{d^3 S}{5.1} = 0.1963 d^3 S; \quad d = \sqrt[3]{\frac{5.1 Pa}{S}} = \sqrt[3]{\frac{Pa}{K}}$$

If  $R$  = revolutions per minute, then the horse-power transmitted =

$$\text{H.P.} = \frac{Pa \ 2 \ \pi R}{33,000 \times 12} = \frac{\pi d^3 S \times 2 \ \pi R}{16 \times 33,000 \times 12} = \frac{RSd^3}{321,000};$$

$$d = \sqrt[3]{\frac{321,000 \ \text{H.P.}}{RS}} = \sqrt[3]{\frac{C \times \text{H.P.}}{R}}$$

In practice, empirical values are given to  $S$  and to the coefficients  $K = 5.1/S$  and  $C = 321,000/S$ , according to the factor of safety assumed, depending on the material, on whether the shaft is subjected to steady, fluctuating, bending, or reversed strains, on the distance between bearings, etc. Kimball and Barr (Machine Design) state that the following factors of safety are indicated by successful practice: For head shafts, 15; for line shafts carrying pulleys, 10; for small short shafts, countershafts, etc., 7. For steel shafting the allowable stress,  $S$ , for the above factors would be about 4000, 6000 and 8500 lbs. respectively, whence

for head shafts  $d = \sqrt[3]{\frac{80 \ \text{H.P.}}{R}}$ ; for line shafts  $d = \sqrt[3]{\frac{53 \ \text{H.P.}}{R}}$ ; for short shafts  $d = \sqrt[3]{\frac{38 \ \text{H.P.}}{R}}$ .

Jones & Laughlin Steel Co. gives the following for steel shafts:

	Turned.	Cold-rolled.
For simply transmitting power and short countershafts, bearings not more than 8 ft. apart	H.P. = $d^3 R \div 50$	H.P. = $d^3 R \div 40$
As second movers, or line shafts, bearings 8 ft. apart	H.P. = $d^3 R \div 90$	H.P. = $d^3 R \div 70$
As prime movers or head shafts carrying main driving pulley or gear, well supported by bearings	H.P. = $d^3 R \div 125$	H.P. = $d^3 R \div 100$

Jones & Laughlins give the following notes: Receiving and transmitting pulleys should always be placed as close to bearings as possible; and it is good practice to frame short "headers" between the main tie-beams of a mill so as to support the *main receivers*, carried by the head shafts, with a bearing close to each side as is contemplated in the formulæ. But if it is preferred, or necessary, for the shaft to span the full width of the "bay" without intermediate bearings, or for the pulley to be placed away from the bearings towards or at the middle of the bay, the size of the shaft must be largely increased to secure the *stiffness* necessary to support the load without undue deflection.

Diameter of shaft  $D$  to carry load at center of bays from 2 to 12 ft. span,  $D = \sqrt[4]{\frac{c}{c_1} d^4}$ , in which  $d$  is the diameter derived from the formula for head shafts,  $c$  = length of bay in inches, and  $c_1$  = distance in inches between centers of bearings in accordance with the formula for horse-

power of head shafts. (Jones & Laughlin Steel Co.) Values of  $c_1$  for different diameters  $d$  are as follows:

$d$	$c_1$	$d$	$c_1$	$d$	$c_1$	$d$	$c_1$	$d$	$c_1$	$d$	$c_1$
1 to 1 <sup>3</sup> / <sub>8</sub>	15	2 <sup>13</sup> / <sub>16</sub>	25	3 <sup>15</sup> / <sub>16</sub> & 4	37	5 <sup>1</sup> / <sub>4</sub> & 5 <sup>3</sup> / <sub>8</sub>	55	6 <sup>3</sup> / <sub>8</sub>	71	7 <sup>3</sup> / <sub>8</sub>	88
1 <sup>11</sup> / <sub>16</sub> & 1 <sup>3</sup> / <sub>4</sub>	16	2 <sup>7</sup> / <sub>8</sub> to 3	26	4 <sup>3</sup> / <sub>16</sub>	40	5 <sup>1</sup> / <sub>2</sub>	57	6 <sup>1</sup> / <sub>2</sub>	73	7 <sup>1</sup> / <sub>2</sub>	91
1 <sup>13</sup> / <sub>16</sub> & 1 <sup>7</sup> / <sub>8</sub>	17	3 <sup>1</sup> / <sub>8</sub> to 3 <sup>1</sup> / <sub>4</sub>	28	4 <sup>1</sup> / <sub>4</sub>	41	5 <sup>5</sup> / <sub>8</sub>	59	6 <sup>5</sup> / <sub>8</sub>	75	7 <sup>5</sup> / <sub>8</sub>	93
1 <sup>15</sup> / <sub>16</sub> to 2 <sup>1</sup> / <sub>8</sub>	18	3 <sup>3</sup> / <sub>8</sub>	30	4 <sup>7</sup> / <sub>16</sub> & 4 <sup>1</sup> / <sub>2</sub>	44	5 <sup>3</sup> / <sub>4</sub>	61	6 <sup>3</sup> / <sub>4</sub>	77	7 <sup>3</sup> / <sub>4</sub>	96
2 <sup>3</sup> / <sub>16</sub> & 2 <sup>1</sup> / <sub>4</sub>	19	3 <sup>7</sup> / <sub>16</sub> & 3 <sup>1</sup> / <sub>2</sub>	31	4 <sup>3</sup> / <sub>4</sub>	47	5 <sup>7</sup> / <sub>8</sub>	63	6 <sup>7</sup> / <sub>8</sub>	79	7 <sup>7</sup> / <sub>8</sub>	99
2 <sup>5</sup> / <sub>16</sub> to 2 <sup>7</sup> / <sub>16</sub>	20	3 <sup>9</sup> / <sub>16</sub> & 3 <sup>5</sup> / <sub>8</sub>	33	4 <sup>13</sup> / <sub>16</sub>	49	6	65	7	81	8	101
2 <sup>1</sup> / <sub>2</sub> to 2 <sup>5</sup> / <sub>8</sub>	24	3 <sup>11</sup> / <sub>16</sub> & 3 <sup>3</sup> / <sub>4</sub>	34	5	51	6 <sup>1</sup> / <sub>8</sub>	67	7 <sup>1</sup> / <sub>8</sub>	84	8 <sup>1</sup> / <sub>2</sub>	112
2 <sup>1</sup> / <sub>16</sub> & 2 <sup>3</sup> / <sub>4</sub>	22	3 <sup>7</sup> / <sub>8</sub>	36	5 <sup>1</sup> / <sub>8</sub>	52	6 <sup>1</sup> / <sub>4</sub>	69	7 <sup>1</sup> / <sub>4</sub>	86	9	123

Should the load be applied near one end of the span or bay instead of at the center, multiply the fourth power of the diameter of the shaft required to carry the load at the center of the span or bay by the product of the two parts of the shaft when the load is near one end, and divide this product by the product of the two parts of the shaft when the load is carried at the center. The fourth root of this quotient will be the diameter required.

The shaft in a line which carries a receiving-pulley, or which carries a transmitting-pulley to drive another line, should always be considered a head-shaft, and should be of the size given by the rules for shafts carrying main pulleys or gears.

The greatest admissible distance between bearings of shafts subject to no transverse strain except from their own weight is for cold-rolled shafts,  $L = \sqrt[3]{330,608 \times D^2}$ , and for turned shafts,  $L = \sqrt[3]{319,586 \times D^2}$ .  $D =$  diam. and  $L =$  length of shaft, in inches. These formulæ are based on an allowable deflection at the center of  $\frac{1}{80}$  in. per foot of length, weight of steel 490 lbs. per cu. ft., and modulus of elasticity = 29,000,000 for turned and 30,000,000 for cold-rolled shafting. [In deriving these formulæ the weight of the shaft has been taken as a concentrated instead of a distributed load, giving additional safety.]

Kimball and Barr say that the lateral deflection of a shaft should not exceed 0.01 in. per foot of length, to insure proper contact at the bearings. For ordinary small shafting they give the following as the allowable distance between the hangers:  $L = 7 \sqrt[3]{d^2}$ , for shaft without pulleys;  $L = 5 \sqrt[3]{d^2}$ , for shaft carrying pulleys. ( $L$  in ft.,  $d$  in ins.)

**Deflection of Shafting.** (Pencoyd Iron Works.) — For continuous line-shafting it is considered good practice to limit the deflection to a maximum of  $\frac{1}{100}$  of an inch per foot of length. The weight of bare shafting in pounds =  $2.6 d^2 L = W$ , or when as fully loaded with pulleys as is customary in practice, and allowing 40 lbs. per inch of width for the vertical pull of the belts, experience shows the load in pounds to be about  $13 d^2 L = W$ . Taking the modulus of transverse elasticity at 26,000,000 lbs., we derive from authoritative formulæ the following:

$$L = \sqrt[3]{873 d^2}, \quad d = \sqrt{L^3/873}, \quad \text{for bare shafting;}$$

$$L = \sqrt[3]{175 d^2}, \quad d = \sqrt{L^3/175}, \quad \text{for shafting carrying pulleys, etc.,}$$

$L$  being the maximum distance in feet between bearings for continuous shafting subjected to bending stress alone,  $d =$  diam. in inches.

The torsional stress is inversely proportional to the velocity of rotation, while the bending stress will not be reduced in the same ratio. It is therefore impossible to write a formula covering the whole problem and sufficiently simple for practical application, but the following rules are correct within the range of velocities usual in practice.

For continuous shafting so proportioned as to deflect not more than

$\frac{1}{100}$  of an inch per foot of length, allowance being made for the weakening effect of key-seats,

$$d = \sqrt[3]{50 \text{ H.P.} \div R}, L = \sqrt[3]{720 d^2}, \text{ for bare shafts;}$$

$$d = \sqrt[3]{70 \text{ H.P.} \div R}, L = \sqrt[3]{140 d^2}, \text{ for shafts carrying pulleys, etc.}$$

$d$  = diam. in inches,  $L$  = length in feet,  $R$  = revs. per min.

The following are given by J. B. Francis as the greatest admissible distances between the bearings of continuous steel shafts subject to no transverse strain except from their own weight, as would be the case were the power given off from the shaft equal on all sides, and at an equal distance from the hanger-bearings.

Diam. of shaft, in. . . . .	2	3	4	5	6	7	8	9
Dist. bet. bearings, ft.	15.9	18.2	20.0	21.6	22.9	24.1	25.2	26.2

These conditions, however, do not usually obtain in the transmission of power by belts and pulleys, and the varying circumstances of each case render it impracticable to give any rule which would be of value for universal application.

For example, the theoretical requirements would demand that the bearings be nearer together on those sections of shafting where most power is delivered from the shaft, while considerations as to the location and desired contiguity of the driven machines may render it impracticable to separate the driving-pulleys by the intervention of a hanger at the theoretically required location. (Joshua Rose.)

**Horse-Power Transmitted by Cold-rolled Steel Shafting at Different Speeds as Prime Movers or Head Shafts Carrying Main Driving Pulley or Gear, well Supported by Bearings.**

$$\text{Formula H.P.} = d^3 R \div 100.$$

Revolutions per minute.						Revolutions per minute.					
Diam.	100	200	300	400	500	Diam.	100	200	300	400	500
1 1/2	3.4	6.7	10.1	13.5	16.9	27/8	24	48	72	95	119
1 9/16	3.8	7.6	11.4	15.2	19.0	2 15/16	25	51	76	101	127
1 5/8	4.3	8.6	12.8	17.1	21	3	27	54	81	108	135
1 11/16	4.8	9.6	14.4	19.2	24	3 1/8	31	61	91	122	152
1 3/4	5.4	10.7	16.1	21	27	3 3/16	32	65	97	129	162
1 13/16	5.9	11.9	17.8	24	30	3 1/4	34	69	103	137	172
1 7/8	6.6	13.1	19.7	26	33	3 3/8	38	77	115	154	192
1 15/16	7.3	14.5	22	29	36	3 7/16	41	81	122	162	203
2	8.0	16.0	24	32	40	3 1/2	43	86	128	171	214
2 1/16	8.8	17.6	26	35	44	3 9/16	45	90	136	180	226
2 1/8	9.6	19.2	29	38	48	3 5/8	48	95	143	190	238
2 3/16	10.5	21	31	42	52	3 11/16	50	100	150	200	251
2 1/4	11.4	23	34	45	57	3 3/4	55	105	158	211	264
2 5/16	12.4	25	37	49	62	3 7/8	58	116	174	233	291
2 3/8	13.4	27	40	54	67	3 15/16	61	122	183	244	305
2 7/16	14.5	29	43	58	72	4	64	128	192	256	320
2 1/2	15.6	31	47	62	78	4 3/16	74	147	221	294	367
2 9/16	16.8	34	50	67	84	4 1/4	77	154	230	307	383
2 5/8	18.1	36	54	72	90	4 7/16	88	175	263	350	438
2 11/16	19.4	39	58	77	97	4 1/2	91	182	273	365	456
2 3/4	21	41	62	83	104	4 3/4	107	214	322	429	537
2 13/16	22	44	67	89	111	5	125	250	375	500	625

For H.P. transmitted by turned steel shafts, as prime movers, etc., multiply the figures by 0.8.

For shafts, as second movers or line shafts, } Cold-rolled Turned  
bearings 8 ft. apart, multiply by } 1.43 1.11

For simply transmitting power, short counter-shafts, etc., bearings not over 8 ft. apart, multiply by 2 2.50



The horse-power is directly proportional to the number of revolutions per minute.

SPEED OF SHAFTING. — Machine shops.....	120 to 240
Wood-working.....	250 to 300
Cotton and woollen mills..	300 to 400

**Flange Couplings.** — The bolts should be designed so that their combined resistance to a torsional moment around the axis of the shaft is at least as great as the torsional strength of the shaft itself; and the bolts should be accurately fitted so as to distribute the load evenly among them. Let  $D$  = diam. of the shaft,  $d$  = diam. of the bolts,  $r$  = radius of bolt circle, in inches,  $n$  = number of bolts,  $S$  = allowable shear-stress per sq. in., then  $\pi d^3 S \div 16 = 1/4 \pi d^2 r S$ , whence  $d = 0.5 \sqrt{D^3 / (nr)}$ . Kimball and Barr give  $n = 3 + D/2$ , but this number may be modified for convenience in spacing, etc.

**Effect of Cold Rolling.** — Experiments by Prof. R. H. Thurston in 1902 on hot-rolled and cold-rolled steel bars (Catalogue of Jones & Laughlin Steel Co.) showed that the cold-rolled steel in tension had its elastic limit increased 15 to 97%; tensile strength increased 20 to 45%; ductility decreased 40 to 69%. In transverse tests the resistance increased 11 to 30% at the elastic limit and 13 to 69% at the yield point. In torsion the resistance at the yield point increased 31 to 64%, and at the point of fracture it decreased 4 to 10%. The angle of torsion at the elastic limit increased 59 to 103%, while the ultimate angle decreased 19 to 28%. Bars turned from 1 3/4 in. diam. to various sizes down to 0.35 in. showed that the change in quality produced by cold rolling extended to the center of the bar. The maximum strength of the cold-rolled bar of full size was 82,200 lbs. per sq. in., and that of the smallest bar 73,600 lbs. In the hot-rolled steel bars the maximum strength of the full-sized bar was 62,900 lbs. and that of the smallest bar 58,600 lbs. per sq. in.

**Hollow Shafts.** — Let  $d$  be the diameter of a solid shaft, and  $d_1 d_2$  the external and internal diameters of a hollow shaft of the same material. Then the shafts will be of equal torsional strength when  $d^3 = \frac{d_1^4 - d_2^4}{d_1}$ .

A 10-inch hollow shaft with internal diameter of 4 inches will weigh 16% less than a solid 10-inch shaft, but its strength will be only 2.56% less. If the hole were increased to 5 inches diameter the weight would be 25% less than that of the solid shaft, and the strength 6.25% less.

**Table for Laying Out Shafting.** — The table on the next page (from the *Stevens Indicator*, April, 1892) is used by Wm. Sellers & Co. to facilitate the laying out of shafting.

The wood-cuts at the head of this table show the position of the hangers and position of couplings, either for the case of extension in both directions from a central head-shaft or extension in one direction from that head-shaft.

**Sizes of Collars for Shafting.** Wm. Sellers & Co., *Am. Mach.* Jan. 28, 1897. —  $D$ , diam. of collar;  $T$ , thickness;  $d$ , diam. of set screw;  $l$ , length. All in inches.

LOOSE COLLARS.

Shaft	$D$	$T$	$d$	$l$	Shaft	$D$	$T$	$d$	$l$	Shaft	$D$	$t$	$d$	$l$
1	13/4	3/4	7/16	5/16	2 1/4	3 3/8	13/16	5/8	5/8	4	5 13/16	17/8	3/4	1
1 1/4	17/8	13/16	7/16	3/8	2 1/2	3 3/4	1 1/4	5/8	11/16	4 1/2	6 7/16	17/8	3/4	1
1 1/2	2 1/4	15/16	7/16	7/16	2 3/4	4	15/16	5/8	11/16	5	6 15/16	17/8	3/4	1
1 5/8	2 5/8	1	7/16	7/16	3	4 1/2	17/16	5/8	13/16	5 1/2	7 1/2	2	3/4	1
1 3/4	2 3/4	1 1/16	1/2	9/16	3 1/4	4 7/8	15/8	3/4	13/16	6	8	2	3/4	1
2	3	1 1/8	5/8	9/16	3 1/2	5 3/16	1 3/4	3/4	15/16					

FAST COLLARS.

Shaft	$D$	$T$	Shaft	$D$	$T$	Shaft	$D$	$T$	Shaft	$D$	$T$
1 1/2	2	1/2	2 1/2	3 1/4	9/16	3 1/2	4 5/8	7/8	5 1/2	7 5/8	13/16
1 3/4	2 1/4	1/2	2 3/4	3 5/8	5/8	4	5 3/8	15/16	6	8 1/4	1 1/4
2	2 5/8	1/2	3	4	11/16	4 1/2	6	1	6 1/2	9	1 3/8
2 1/4	3	9/16	3 1/4	4 1/4	11/16	5	7	1 1/8	7	9 3/4	1 1/2

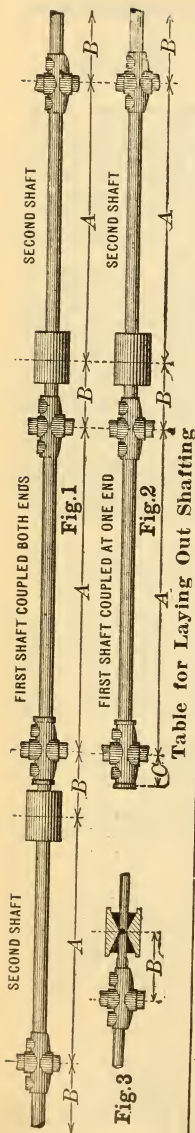

Table for Laying Out Shafting

Length of Collared End for Fast Coll., ins.	Nominal Size of 2d Shaft.	Nominal Size of 1st Shaft, ins.	Distance from Center of Bearing to End of Shaft for Coupling. See B, Figs. 1, 2, and 3.												Length of Bearing, ins.	Length, Inches.	Diameter, Inches.				
3 1/2	1 1/2	1 1/2	1 1/2	2 1/4	2 1/2	2 3/4	3	3 1/4	3 1/2	4	4 1/2	5	5 1/2	6	6 1/2	7	7 1/2	8	6	5 1/2	3 3/4
4	13/4	9 1/2	1 1/2	2 1/2	2 3/4	3	3 1/4	3 1/2	4	4 1/2	5	5 1/2	6	6 1/2	7	7 1/2	8	8	7	6 1/2	4 5/8
4 1/2	2	10 1/2	1 1/2	2 3/4	3	3 1/4	3 1/2	4	4 1/2	5	5 1/2	6	6 1/2	7	7 1/2	8	8	9	8	7 1/2	5 3/8
5	2 1/4	11 1/2	1 1/2	3	3 1/4	3 1/2	4	4 1/2	5	5 1/2	6	6 1/2	7	7 1/2	8	8	9	10	9	8 1/4	5 7/8
5 5/8	2 1/2	12	1 1/2	3 1/2	4	4 1/2	5	5 1/2	6	6 1/2	7	7 1/2	8	8 1/2	9	9	10	11	10	9 1/2	6 1/8
6 1/4	2 3/4	12 1/2	2	4	4 1/2	5	5 1/2	6	6 1/2	7	7 1/2	8	8 1/2	9	9 1/2	10	11	12	11	10	6 9/16
6 3/4	3	13	2 1/4	4 1/2	5	5 1/2	6	6 1/2	7	7 1/2	8	8 1/2	9	9 1/2	10	11	12	13	12	11	7
7 1/4	3 1/4	13 1/2	2 1/2	5	5 1/2	6	6 1/2	7	7 1/2	8	8 1/2	9	9 1/2	10	10 1/2	11	12	13	12	11	7 3/4
7 7/8	3 1/2	14	2 3/4	5 1/2	6	6 1/2	7	7 1/2	8	8 1/2	9	9 1/2	10	10 1/2	11	12	13	14	13	12	8 1/4
8 15/16	4	15	3	6	6 1/2	7	7 1/2	8	8 1/2	9	9 1/2	10	10 1/2	11	11 1/2	12	13	14	13	12	8 1/2
10	4 1/2	16	3 1/2	6 1/2	7	7 1/2	8	8 1/2	9	9 1/2	10	10 1/2	11	11 1/2	12	13	14	15	14	13	9 1/16
11 1/8	5	17	4	7	7 1/2	8	8 1/2	9	9 1/2	10	10 1/2	11	11 1/2	12	13	14	15	16	15	14	10
12 3/16	5 1/2	18 1/2	4 1/2	7 1/2	8	8 1/2	9	9 1/2	10	10 1/2	11	11 1/2	12	13	14	15	16	17	16	15	11 3/8
13 1/4	6	20	5	8	8 1/2	9	9 1/2	10	10 1/2	11	11 1/2	12	13	14	15	16	17	18	17	16	12 3/8
14 3/8	6 1/2	21 1/2	5 1/2	8 1/2	9	9 1/2	10	10 1/2	11	11 1/2	12	13	14	15	16	17	18	19	18	17	12 9/16
15 1/2	7	22	6	9	9 1/2	10	10 1/2	11	11 1/2	12	13	14	15	16	17	18	19	20	19	18	13 1/8
16 1/2	7 1/2	23	6 1/2	9 1/2	10	10 1/2	11	11 1/2	12	13	14	15	16	17	18	19	20	21	20	19	13 3/8
17 3/4	8	25	7	10	10 1/2	11	11 1/2	12	13	14	15	16	17	18	19	20	21	22	21	20	14 1/8
		26 1/2	7 1/2	10 1/2	11	11 1/2	12	13	14	15	16	17	18	19	20	21	22	23	22	21	14 3/8
		28 3/8		11 1/2	12	12 1/2	13	14	15	16	17	18	19	20	21	22	23	24	23	22	15 1/8
		28 3/8		12 1/2	13	13 1/2	14	15	16	17	18	19	20	21	22	23	24	25	24	23	15 3/8
		19 5/16		13 1/2	14	14 1/2	15	16	17	18	19	20	21	22	23	24	25	26	25	24	16 1/8
		19 5/16		14 1/2	15	15 1/2	16	17	18	19	20	21	22	23	24	25	26	27	26	25	16 3/8
		19 5/16		15 1/2	16	16 1/2	17	18	19	20	21	22	23	24	25	26	27	28	27	26	17 1/8
		19 5/16		16 1/2	17	17 1/2	18	19	20	21	22	23	24	25	26	27	28	29	28	27	17 3/8
		19 5/16		17 1/2	18	18 1/2	19	20	21	22	23	24	25	26	27	28	29	30	29	28	17 7/8
		19 5/16		18 1/2	19	19 1/2	20	21	22	23	24	25	26	27	28	29	30	31	30	29	18 1/8
		19 5/16		19 1/2	20	20 1/2	21	22	23	24	25	26	27	28	29	30	31	32	31	30	18 3/8
		19 5/16		20 1/2	21	21 1/2	22	23	24	25	26	27	28	29	30	31	32	33	32	31	18 7/8
		19 5/16		21 1/2	22	22 1/2	23	24	25	26	27	28	29	30	31	32	33	34	33	32	19 1/8
		19 5/16		22	23	23 1/2	24	25	26	27	28	29	30	31	32	33	34	35	34	33	19 3/8
		19 5/16		23	24	24 1/2	25	26	27	28	29	30	31	32	33	34	35	36	35	34	19 7/8
		19 5/16		24	25	25 1/2	26	27	28	29	30	31	32	33	34	35	36	37	36	35	20 1/8
		19 5/16		25	26	26 1/2	27	28	29	30	31	32	33	34	35	36	37	38	37	36	20 3/8
		19 5/16		26 1/2	27	27 1/2	28	29	30	31	32	33	34	35	36	37	38	39	38	37	20 7/8
		19 5/16		27 1/2	28	28 1/2	29	30	31	32	33	34	35	36	37	38	39	40	39	38	21 1/8
		19 5/16		28 1/2	29	29 1/2	30	31	32	33	34	35	36	37	38	39	40	41	40	39	21 3/8
		19 5/16		29 1/2	30	30 1/2	31	32	33	34	35	36	37	38	39	40	41	42	41	40	21 7/8
		19 5/16		30 1/2	31	31 1/2	32	33	34	35	36	37	38	39	40	41	42	43	42	41	22 1/8
		19 5/16		31 1/2	32	32 1/2	33	34	35	36	37	38	39	40	41	42	43	44	43	42	22 3/8
		19 5/16		32 1/2	33	33 1/2	34	35	36	37	38	39	40	41	42	43	44	45	44	43	22 7/8
		19 5/16		33	34	34 1/2	35	36	37	38	39	40	41	42	43	44	45	46	45	44	23 1/8

USE OF TABLE.— Look for size of first shaft in left-hand column, under the head of Size of first shaft, and in the top line of table, marked Size of second shaft, find the size of the shaft to be coupled to it. The intersection gives the length B; this added to the length A, or distance from center to center of bearing, and in cases similar to Fig. 2, to the length C, gives the length of the first shaft, thus: as in Fig. 1, B+A+B= length; Fig. 2, C+A+B=length.

Make bearings at equal distances from each other, when practicable, and always put two bearings on the first, which is the collared shaft. See Figs. 1 and 2.

In coupling shafts of different sizes, either reduce the end of the large shaft in diameter, and use a small coupling, or use a coupling to suit the larger shaft, with one cone bored for the smaller nominal shaft.

PULLEYS.

**Proportions of Pulleys.** (See also Fly-wheels, page 1049.) — Let  $n$  = number of arms,  $D$  = diameter of pulley,  $S$  = thickness of belt,  $t$  = thickness of rim at edge,  $T$  = thickness in middle,  $B$  = width of rim,  $\beta$  = width of belt,  $h$  = breadth of arm at hub,  $h_1$  = breadth of arm at rim,  $e$  = thickness of arm at hub,  $e_1$  = thickness of arm at rim,  $c$  = amount of crowning; dimensions in inches.

	Unwin.	Reuleaux.
$B$ = width of rim.....	$9/8 (\beta + 0.4)$	$9/8 \beta$ to $5/4 \beta$
$t$ = thickness at edge of rim.....	$0.7 S + 0.005 D$	{ (thick. of rim.) $1/5 h$ to $1/4 h$
$T$ = thickness at middle of rim...	$2t + c$	.....
$h$ = breadth of arm at hub.....	$\left\{ \begin{array}{l} \text{For single belts} = 0.6337 \sqrt[3]{\frac{BD}{n}} \\ \text{For double belts} = 0.798 \sqrt[3]{\frac{BD}{n}} \end{array} \right. 1/4 \text{ in.} + \frac{B}{4} + \frac{D}{20 n}$	
$h_1$ = breadth of arm at rim.....	$2/3 h$	$0.8 h$
$e$ = thickness of arm at hub.....	$0.4 h$	$0.5 h$
$e_1$ = thickness of arm at rim.....	$0.4 h_1$	$0.5 h_1$
$n$ = number of arms, for a single set	$3 + \frac{BD}{150}$	$1/2 \left( 5 + \frac{D}{2B} \right)$
$L$ = length of hub.....	{ not less than $2.5 S$ , is often $2/3 B$ .	{ $B$ for sin.-arm pulleys. $2 B$ for double-arm pulleys. $h$ to $3/4 h$
$M$ = thickness of metal in hub.....	.....	.....
$c$ = crowning of pulley.....	$1/24 B$	.....

The number of arms is really arbitrary, and may be altered if necessary, (Unwin.)

Pulleys with two or three sets of arms may be considered as two or three separate pulleys combined in one, except that the proportions of the arms should be 0.8 or 0.7 that of single-arm pulleys. (Reuleaux.)

EXAMPLE. — Dimensions of a pulley 60 in. diam., 16 in. face, for double belt 1/2 in. thick.

Solution by	$n$	$h$	$h_1$	$e$	$e_1$	$t$	$T$	$L$	$M$	$c$
Unwin.....	9	3.79	2.53	1.52	1.01	0.65	1.97	10.7	3.8	0.67
Reuleaux.....	4	5.0	4.0	2.5	2.0	1.25		16	5	

The following proportions are given in an article in the *Amer. Machinist* authority not stated:

$h = 0.3625 D + 0.5$  in.,  $h_1 = 0.04 D + 0.3125$  in.,  $e = 0.025 D + 0.2$  in.,  $e_1 = 0.016 D + 0.125$  in.

These give for the above example:  $h = 4.25$  in.,  $h_1 = 2.71$  in.,  $e = 1.7$  in.,  $e_1 = 1.09$  in. The section of the arms in all cases is taken as elliptical.

The following solution for breadth of arm is proposed by the author: Assume a belt pull of 45 lbs. per inch of width of a single belt, that the whole strain is taken in equal proportions on one-half of the arms, and that the arm is a beam loaded at one end and fixed at the other. We have the formula for a beam of elliptical section  $fP = 0.0982 Rbd^2 \div l$ , in which  $P$  = the load,  $R$  = the modulus of rupture of the cast iron,  $b$  = breadth,  $d$  = depth, and  $l$  = length of the beam, and  $f$  = factor of safety. Assume a modulus of rupture of 36,000 lbs., a factor of safety of 10, and an additional allowance for safety in taking  $l = 1/2$  the diameter of the pulley instead of  $1/2 D$  less the radius of the hub.

Take  $d = h$ , the breadth of the arm at the hub, and  $b = e = 0.4 h$  the thickness. We then have  $fP = 10 \times \frac{45 B}{n \div 2} = 900 \frac{B}{n} = \frac{3535 \times 0.4 h^3}{1/2 D}$ ,

whence  $h = \sqrt[3]{\frac{900 BD}{3535 n}} = 0.633 \sqrt[3]{\frac{BD}{n}}$ , which is practically the same as the value reached by Unwin from a different set of assumptions.



**Relation of Belt Width to Pulley Face.** (*Am. Mach.*, Feb. 11, 1915.)—Carl G. Barth recommends that the relation between the face of the pulley and the belt be expressed by the formula  $F = 1^{3/16} B + 3/8$  in., in which  $F$  and  $B$  are the widths respectively of the pulley face and belt, both in inches. If the limits of design make it impractical to use the dimension given by the equation, the following equation may be substituted:  $F = 1^{3/32} B + 3/16$  in.

**Convexity of Pulleys.**—Authorities differ. Morin gives a rise equal to  $1/10$  of the face; Molesworth,  $1/24$ ; others from  $1/8$  to  $1/96$ . Scott A. Smith says the crown should not be over  $1/8$  inch for a 24-inch face. Pulleys for shifting belts should be "straight," that is, without crowning. Mr. Barth uses the formula  $H = 0.03125 F^{2/3}$ , in which  $H$  is the height of crown and  $F$  the width of face in inches.

### CONE OR STEP PULLEYS.

To find the diameters for the several steps of a pair of cone-pulleys:

1. **Crossed Belts.**—Let  $D$  and  $d$  be the diameters of two pulleys connected by a crossed belt,  $L$  = the distance between their centers, and  $\beta$  = the angle either half of the belt makes with a line joining the centers of the pulleys: then total length of belt =  $(D+d) \frac{\pi}{2} + (D+d) \frac{\pi\beta}{180} + 2L \cos \beta$ .  $\beta$  = angle whose sine is  $\frac{D+d}{2L}$ .  $L \cos \beta = \sqrt{L^2 - \left(\frac{D+d}{2}\right)^2}$ .

The length of the belt is constant when  $D + d$  is constant; that is, in a pair of step-pulleys the belt tension will be uniform when the sum of the diameters of each opposite pair of steps is constant. Crossed belts are seldom used for cone-pulleys, on account of the friction between the rubbing parts of the belt.

To design a pair of tapering speed-cones, so that the belt may fit equally tight in all positions: When the belt is crossed, use a pair of equal and similar cones tapering opposite ways.

2. **Open Belts.**—When the belt is uncrossed, use a pair of equal and similar conoids tapering opposite ways, and bulging in the middle, according to the following formula: Let  $L$  denote the distance between the axes of the conoids;  $R$  the radius of the larger end of each;  $r$  the radius of the smaller end; then the radius in the middle,  $r_0$ , is found as follows:

$$r_0 = \frac{R+r}{2} + \frac{(R-r)^2}{6.28L}. \quad (\text{Rankine.})$$

If  $D_0$  = the diameter of equal steps of a pair of cone-pulleys,  $D$  and  $d$  = the diameters of unequal opposite steps, and  $L$  = distance between the axes,  $D_0 = \frac{D+d}{2} + \frac{(D-d)^2}{12.566L}$ .

If a series of differences of radii of the steps,  $R - r$ , be assumed, then for each pair of steps  $\frac{R+r}{2} = r_0 - \frac{(R-r)^2}{6.28L}$ , and the radii of each may be computed from their half sum and half difference, as follows:

$$R = \frac{R+r}{2} + \frac{R-r}{2}; \quad r = \frac{R+r}{2} - \frac{R-r}{2}.$$

A. J. Frith (*Trans. A. S. M. E.*, x, 298) shows the following application of Rankine's method: If we had a set of cones to design, the extreme diameters of which, including thickness of belt, were 40 ins. and 10 ins., and the ratio desired 4, 3, 2, and 1, we would make a table as follows,  $L$  being 100 ins.:

Trial Sum of $D+d$	Ratio.	Trial Diams.		Values of $\frac{(D-d)^2}{12.56L}$	Amount to be Added.	Corrected Values.	
		$D$	$d$			$D$	$d$
50	4	40	10	0.7165	0.0000	40	10
50	3	37.5	12.5	.4975	.2190	37.7190	12.7190
50	2	33.333	16.666	.2212	.4953	33.8286	17.1619
50	1	25	25	.0000	.7165	25.7165	25.7165

The above formulæ are approximate, and they do not give satisfactory

results when the difference of diameters of opposite steps is large and when the axes of the pulleys are near together, giving a large belt-angle. Two more accurate solutions of the problem, one by a graphical method, and another by a trigonometrical method derived from it, are given by C. A. Smith (*Trans. A. S. M. E.* x, 269). These were copied in earlier editions of this Pocket-book, but are now replaced by formulæ derived from a graphical solution by Burmester ("*Lehrbuch der Kinematic*"; *Mach's* Reference Series, No. 14, 1908), which give results far more accurate than are required in practice.

In all cases 0.8 of the thickness of the belt should be subtracted from the calculated diameter to obtain the actual diameter of the pulley. This should be done because the belt drawn tight around the pulleys is not the same length as a tape-line measure around them.—(C. A. Smith.)

Using Burmester's diagram the author has devised an algebraic solution of the problem (*Indust. Eng.*, June, 1910) which leads to the following equations:

- Let  $L$  = distance between the centers.
- $r_0$  = radius of the steps of equal diameter on the two cones.
- $r_1, r_2$  = radii of any pair of steps.
- $a = 0.79057 L - r_0$ .

If  $r_1$  is given,  $r_2 = \sqrt{1.25 L^2 - (0.79057 L - r_0 + r_1)^2} - 0.79057 L + r_0$ .  
 If the ratio  $r_2 \div r_1$  is given, let  $r_2/r_1 = c: r_2 = cr_1$ .

We then have  $a + cr_1 = \sqrt{R^2 - (a + r_1)^2}$ , which reduces to  $(1 + c^2)r_1^2 + 2a(1 + c)r_1 = 1.25 L^2 - 2a^2$ , a quadratic equation, in which  $a = 0.79057 L - r_0$ . Substituting the value of  $a$  we have

$$(1 + c^2)r_1^2 + (1.58114 L - 2r_0)(1 + c)r_1 = 3.16228 Lr_0 - 2r_0^2,$$

in which  $L, r_0$  and  $c$  are given and  $r_1$  is to be found.

Let  $L = 100, c = 4, r_0 = 12.858$  as in Mr. Frith's example, page 1136. Then  $17r_1^2 + 10ar_1 = 12,500 - 8764.62$ , from which  $r_1 = 5.001, r_2 = 20.004$ .  
 If  $c = 3, r_1 = 6.304, r_2 = 18.912$ . If  $c = 2, r_1 = 8.496, r_2 = 16.992$ .

Checking the results by the approximate formula for length of belt, page 1148, viz, Length =  $2L + \pi(r_1 + r_2) + (r_2 - r_1)^2 \div L$ , we have

- for  $c = 1, 200 + 80.79 + 0 = 280.79$
- 2,  $200 + 80.07 + 0.72 = 280.79$
- 3,  $200 + 79.22 + 1.59 = 280.81$
- 4,  $200 + 78.56 + 2.25 = 280.81$

The maximum difference being only 1 part in 14,000.

J. J. Clark (*Indust. Eng.*, Aug., 1910) gives the following solution:

Using the same notation as above,

$$\frac{(c - 1)^2}{L} r_1^2 + \pi(c + 1)r_1 = 2\pi r_0 \dots\dots\dots (1)$$

$$\pi(c + 1)r_1 + Lx \left( \frac{60 - 13x}{60 - 18x} \right) = 2\pi r_0 \dots\dots\dots (2)$$

$$x = (r_2 - r_1)^2 \div L^2 \dots\dots\dots (3)$$

The quadratic equation (1) gives the value of  $r_1$  with an approximation to accuracy sufficient for all practical purposes. If greater accuracy is for any reason desired it may be obtained by (2) and (3), using in (3) the values of  $r_1$  and  $r_2 = cr_1$ , already found from (1). Taking  $\pi = 3.1415927$ , the result will be correct to the seventh figure.

**Speeds of Shaft with Cone Pulleys.**—If  $S$  = speed (revs. per min.) of the driving shaft,

$s_1, s_2, s_3, s_n$  = speeds of the driven shaft,

$D_1, D_2, D_3, D_n$  = diameters of the pulleys on the driving cone,

$d_1, d_2, d_3, d_n$  = diams. of corresponding pulleys on the driven cone,

$SD_1 = s_1 d_1; SD_2 = s_2 d_2$ , etc.

$s_1/S = D_1/d_1 = r_1; s_n/S = D_n/d_n = r_n$ .

The speed of the driving shaft being constant, the several speeds of

the driven shaft are proportional to the ratio of the diameter of the driving pulley to that of the driven, or to  $D/d$ .

**Speeds in Geometrical Progression.** — If it is desired that the speed ratios shall increase by a constant percentage, or in geometrical progression, then  $r_2/r_1 = r_3/r_2 = r_n/r_{n-1} = c$ , a constant.

$$r_n \div r_1 = c^{n-1}; \quad c = \sqrt[n-1]{r_n \div r_1}$$

**EXAMPLE.** If the speed ratio of the driven shaft at its lowest speed, to the driving shaft be 0.76923, and at its highest speed 2.197, the speeds being in geometrical progression, what is the constant multiplier if  $n=5$ ?

$$\begin{aligned} \text{Log } 2.197 &= 0.341830 \\ \text{Log } 0.76923 &= 1.886056 \end{aligned}$$

$$\hline 0.455774$$

Divide by  $n-1 = 4$ ,  $0.113943 = \log$  of 1.30.

If  $D_2/d_2 = 1$ , then  $D_1/d_1 = 1 \div 1.3 = 0.769$ ;  $D_3/d_3 = 1.30$ ;  $D_4/d_4 = 1.69$ ;  $D_5/d_5 = 2.197$ .

## BELTING.

**Theory of Belts and Bands.** — A pulley is driven by a belt by means of the friction between the surfaces in contact. Let  $T_1$  be the tension on the driving side of the belt,  $T_2$  the tension on the loose side; then  $S = T_1 - T_2$ , is the total friction between the band and the pulley, which is equal to the tractive or driving force. Let  $f$  = the coefficient of friction,  $\theta$  the ratio of the length of the arc of contact to the length of the radius,  $\alpha$  = the angle of the arc of contact in degrees,  $e$  = the base of the Napierian logarithms = 2.71828,  $m$  = the modulus of the common logarithms = 0.434295. The following formulæ are derived by calculus (Rankine's Mach'y and Millwork, p. 351; Carpenter's Exper. Eng'g, p. 173):

$$\frac{T_1}{T_2} = e^{f\theta}; \quad T_2 = \frac{T_1}{e^{f\theta}}; \quad T_1 - T_2 = T_1 - \frac{T_1}{e^{f\theta}} = T_1(1 - e^{-f\theta}).$$

$$T_1 - T_2 = T_1(1 - e^{-f\theta}) = T_1(1 - 10^{-f\theta m}) = T_1(1 - 10^{-0.00758 f \alpha});$$

$$\frac{T_1}{T_2} = 10^{0.00758 f \alpha}; \quad T_1 = T_2 \times 10^{0.00758 f \alpha}; \quad T_2 = \frac{T_1}{10^{0.00758 f \alpha}}.$$

If the arc of contact between the band and the pulley expressed in turns and fractions of a turn =  $n$ ,  $\theta = 2\pi n$ ;  $e^{f\theta} = 10^{2.7288 f n}$ ; that is,  $e^{f\theta}$  is the natural number corresponding to the common logarithm  $2.7288 f n$ .

The value of the coefficient of friction  $f$  depends on the state and material of the rubbing surfaces. For leather belts on iron pulleys, Morin found  $f = 0.56$  when dry, 0.36 when wet, 0.23 when greasy, and 0.15 when oily. In calculating the proper mean tension for a belt, the smallest value,  $f = 0.15$ , is to be taken if there is a probability of the belt becoming wet with oil. The experiments of Henry R. Towne and Robert Briggs, however (*Jour. Frank. Inst.*, 1868), show that such a state of lubrication is not of ordinary occurrence; and that in designing machinery we may in most cases safely take  $f = 0.42$ . Reuleaux takes  $f = 0.25$ . Later writers have shown that the coefficient is not a constant quantity, but is extremely variable, depending on the velocity of slip, the condition of the surfaces, and even on the weather.

The following table shows the values of the coefficient  $2.7288 f$ , by which  $n$  is multiplied in the last equation, corresponding to different values of  $f$ ; also the corresponding values of various ratios among the forces, when the arc of contact is half a circumference:

	$f = 0.15$	0.25	0.42	0.56
	$2.7288 f = 0.41$	0.68	1.15	1.53
Let $\theta = \pi$ and $n = 1/2$ , then				
	$T_1 \div T_2 = 1.603$	2.188	3.758	5.821
	$T_1 \div S = 2.66$	1.84	1.36	1.21
	$T_1 + T_2 \div 2S = 2.16$	1.34	0.86	0.71



In ordinary practice it is usual to assume  $T_2 = S$ ;  $T_1 = 2 S$ ;  $T_1 + T_2 \div 2 S = 1.5$ . This corresponds to  $f = 0.22$  nearly.

For a wire rope on cast iron  $f$  may be taken as 0.15 nearly; and if the groove of the pulley is bottomed with gutta-percha, 0.25. (Rankine.)

**Centrifugal Tension of Belts.** — When a belt or band runs at a high velocity, centrifugal force produces a tension in addition to that existing when the belt is at rest or moving at a low velocity. This centrifugal tension diminishes the effective driving force.

Rankine says: If an endless band, of any figure whatsoever, runs at a given speed, the centrifugal force produces a uniform tension at each cross-section of the band, equal to the weight of a piece of the band whose length is twice the height from which a heavy body must fall in order to acquire the velocity of the band. (See Cooper on Belting, p. 101.)

If  $T_c$  = centrifugal tension;

$V$  = velocity in feet per second;

$g$  = acceleration due to gravity = 32.2;

$W$  = weight of a piece of the belt 1 ft. long and 1 sq. in. sectional area, —

Leather weighing 56 lbs. per cubic foot gives  $W = 56 \div 144 = 0.388$ .

$$T_c = WV^2 \div g = 0.388 V^2 \div 32.2 = 0.012V^2.$$

**Belting Practice. Handy Formulæ for Belting.** — Since in the practical application of the above formulæ the value of the coefficient of friction must be assumed, its actual value varying within wide limits (15% to 135%), and since the values of  $T_1$  and  $T_2$  also are fixed arbitrarily, it is customary in practice to substitute for these theoretical formulæ more simple empirical formulæ and rules, some of which are given below.

Let  $d$  = diam. of pulley in inches;  $\pi d$  = circumference;

$V$  = velocity of belt in ft. per second;  $v$  = vel. in ft. per minute;

$\alpha$  = angle of the arc of contact:

$L$  = length of arc of contact in feet =  $\pi da \div (12 \times 360)$ ;

$F$  = tractive force per square inch of sectional area of belt;

$w$  = width in inches;  $t$  = thickness;

$S$  = tractive force per inch of width =  $F \times t$ ;

r.p.m. = revs. per minute; r.p.s. = revs. per second = r.p.m.  $\div$  60.

$$V = \frac{\pi d}{12} \times \text{r.p.s.} = \frac{\pi d}{12} \times \frac{\text{r.p.m.}}{60} = 0.004363 d \times \text{r.p.m.} = \frac{d \times \text{r.p.m.}}{229.2};$$

$$v = \frac{\pi d}{12} \times \text{r.p.m.}; = 0.2618 d \times \text{r.p.m.}$$

$$\text{Horse-power, H.P.} = \frac{Svw}{33000} = \frac{SVw}{550} = \frac{Swd \times \text{r.p.m.}}{126050}.$$

If  $F$  = working tension per square inch = 275 lbs., and  $t = 7/32$  inch,  $S = 60$  lbs. nearly, then

$$\text{H.P.} = \frac{vw}{550} = 0.109 Vw = 0.000476 wd \times \text{r.p.m.} = \frac{wd \times \text{r.p.m.}}{2101}. \quad (1)$$

If  $F = 180$  lbs. per square inch, and  $t = 1/6$  inch,  $S = 30$  lbs., then

$$\text{H.P.} = \frac{vw}{1100} = 0.055 Vw = 0.000238 wd \times \text{r.p.m.} = \frac{wd \times \text{r.p.m.}}{4202}. \quad (2)$$

If the working strain is 60 lbs. per inch of width, a belt 1 inch wide traveling 550 ft. per minute will transmit 1 horse-power. If the working strain is 30 lbs. per inch of width, a belt 1 inch wide traveling 1100 ft. per minute will transmit 1 horse-power. Numerous rules are given by different writers on belting which vary between these extremes. A rule commonly used is: 1 inch wide traveling 1000 ft. per min. = 1 H.P.

$$\text{H.P.} = \frac{vw}{1000} = 0.06 Vw = 0.000262 wd \times \text{r.p.m.} = \frac{wd \times \text{r.p.m.}}{3820}. \quad (3)$$

This corresponds to a working strain of 33 lbs. per inch of width.

Many writers give as safe practice for single belts in good condition a working tension of 45 lbs. per inch of width. This gives

$$\text{H.P.} = \frac{vw}{733} = 0.0818 Vw = 0.000357 wd \times \text{r.p.m.} = \frac{wd \times \text{r.p.m.}}{2800}. \quad (4)$$

For double belts of average thickness, some writers say that the transmitting efficiency is to that of single belts as 10 to 7, which would give

$$\text{H.P.} = \frac{wv}{513} = 0.1169 Vw = 0.00051 wd \times \text{r.p.m.} = \frac{wd \times \text{r.p.m.}}{1960} \quad (5)$$

Other authorities, however, make the transmitting power of double belts twice that of single belts, on the assumption that the thickness of a double belt is twice that of a single belt.

Rules for horse-power of belts are sometimes based on the number of square feet of surface of the belt which pass over the pulley in a minute. Sq. ft. per min. =  $wv \div 12$ . The above formulæ translated into this form give:

- (1) For  $S = 60$  lbs. per inch wide; H.P. = 46 sq. ft. per minute.
- (2) "  $S = 30$  " " " H.P. = 92 " "
- (3) "  $S = 33$  " " " H.P. = 83 " "
- (4) "  $S = 45$  " " " H.P. = 61 " "
- (5) "  $S = 64.3$  " " " H.P. = 43 " " (double belt).

The above formulæ are all based on the supposition that the arc of contact is 180°. For other arcs, the transmitting power is approximately proportional to the ratio of the degrees of arc to 180°.

Some rules base the horse-power on the length of the arc of contact in feet. Since  $L = \frac{\pi da}{12 \times 360}$  and  $\text{H.P.} = \frac{Svw}{33000} = \frac{Sw}{33000} \times \frac{\pi d}{12} \times \text{r.p.m.} \times \frac{a}{180}$ , we obtain by substitution  $\text{H.P.} = \frac{Sw}{16500} \times L \times \text{r.p.m.}$ , and the five formulæ then take the following form for the several values of  $S$ :

$$\text{H.P.} = \frac{wL \times \text{r.p.m.}}{275} \quad (1); \quad \frac{wL \times \text{r.p.m.}}{550} \quad (2); \quad \frac{wL \times \text{r.p.m.}}{500} \quad (3); \quad \frac{wL \times \text{r.p.m.}}{367} \quad (4);$$

$$\text{H.P. (double belt)} = \frac{wL \times \text{r.p.m.}}{257} \quad (5).$$

None of the handy formulæ take into consideration the centrifugal tension of belts at high velocities. When the velocity is over 3000 ft. per minute the effect of this tension becomes appreciable, and it should be taken account of, as in Mr. Nagle's formula, which is given below.

**Horse-power of a Leather Belt One Inch wide. (Nagle.)**

Formula:  $\text{H.P.} = CVtw (S - 0.012 V^2) \div 550$ .

For  $f = 0.40$ ,  $a = 180^\circ$ ,  $C = 0.715$ ,  $w = 1$ .

Velocity, ft. per sec.	Laced Belts, $S = 275$ .							Velocity, ft. per sec.	Riveted Belts, $S = 400$ .							
	Thickness in inches = $t$ .								Thickness in inches = $t$ .							
	1/7	1/6	3/16	7/32	1/4	5/16	1/3		7/32	1/4	5/16	1/3	3/8	7/16	1/2	
10	0.51	0.59	0.63	0.73	0.84	1.05	1.18	15	1.69	1.94	2.42	2.58	2.91	3.39	3.87	
15	0.75	0.88	1.00	1.16	1.32	1.66	1.77	20	2.24	2.57	3.21	3.42	3.85	4.49	5.13	
20	1.00	1.17	1.32	1.54	1.75	2.19	2.34	25	2.79	3.19	3.98	4.25	4.78	5.57	6.37	
25	1.23	1.43	1.61	1.88	2.16	2.69	2.86	30	3.31	3.79	4.74	5.05	5.67	6.62	7.58	
30	1.47	1.72	1.93	2.25	2.58	3.22	3.44	35	3.82	4.37	5.46	5.83	6.56	7.65	8.75	
35	1.69	1.97	2.22	2.59	2.96	3.70	3.94	40	4.33	4.95	6.19	6.60	7.42	8.66	9.90	
40	1.90	2.22	2.49	2.90	3.32	4.15	4.44	45	4.85	5.49	6.86	7.32	8.43	9.70	10.98	
45	2.09	2.45	2.75	3.21	3.67	4.58	4.89	50	5.26	6.01	7.51	8.02	9.02	10.52	12.03	
50	2.27	2.65	2.98	3.48	3.98	4.97	5.30	55	5.68	6.50	8.12	8.66	9.74	11.36	13.00	
55	2.44	2.84	3.19	3.72	4.26	5.32	5.69	60	6.09	6.96	8.70	9.28	10.43	12.17	13.91	
60	2.58	3.01	3.38	3.95	4.51	5.64	6.02	65	6.45	7.37	9.22	9.83	11.06	12.90	14.75	
65	2.71	3.16	3.55	4.14	4.74	5.92	6.32	70	6.78	7.75	9.69	10.33	11.62	13.56	15.50	
70	2.81	3.27	3.68	4.29	4.91	6.14	6.54	75	7.09	8.11	10.13	10.84	12.16	14.18	16.21	
75	2.89	3.37	3.79	4.42	5.05	6.31	6.73	80	7.36	8.41	10.51	11.21	12.61	14.71	16.81	
80	2.94	3.43	3.86	4.50	5.15	6.44	6.86	85	7.58	8.66	10.82	11.55	13.00	15.16	17.32	
85	2.97	3.47	3.90	4.55	5.20	6.50	6.93	90	7.74	8.85	11.06	11.80	13.27	15.48	17.69	
90	2.97	3.47	3.90	4.55	5.20	6.50	6.93	100	7.96	9.10	11.37	12.13	13.65	15.92	18.20	

The H.P. becomes a maximum at 87.41 ft. per sec. = 5245 ft. p. min.

The H.P. becomes a maximum at 105.4 ft. per sec. = 6324 ft. per min.

In the above table the angle of subtension, *a*, is taken at 180°.

Should it be.....	90°	100°	110°	120°	130°	140°	150°	160°	170°	180°	200°
Multiply above values by .....	.65	.70	.75	.79	.83	.87	.91	.94	.97	1	1.05

A. F. Nagle's Formula (*Trans. A. S. M. E.*, vol. ii, 1881, p. 91. Tables published in 1882).

$$H.P. = CVtw \left( \frac{S - 0.012 V^2}{550} \right);$$

- C* = 1 - 10<sup>-0.00758 fa</sup>;      *t* = thickness in inches;  
*a* = degrees of belt contact;      *v* = velocity in feet per second;  
*f* = coefficient of friction;      *S* = stress upon belt per square inch.  
*w* = width in inches;

Taking *S* at 275 lbs. per sq. in. for laced belts and 400 lbs. per sq. in. for lapped and riveted belts, the formula becomes

H.P. = *CVtw* (0.50 - 0.0000218 *V*<sup>2</sup>) for laced belts;  
H.P. = *CVtw* (0.727 - 0.0000218 *V*<sup>2</sup>) for riveted belts.

VALUES OF *C* = 1 - 10<sup>-0.00758 fa</sup>. (NAGLE.)

<i>f</i> = coefficient of friction.	Degrees of contact = <i>a</i> .										
	90°	100°	110°	120°	130°	140°	150°	160°	170°	180°	200°
0.15	0.210	0.230	0.250	0.270	0.288	0.307	0.325	0.342	0.359	0.376	0.408
.20	.270	.295	.319	.342	.364	.386	.408	.428	.448	.467	.503
.25	.325	.354	.381	.407	.432	.457	.480	.503	.524	.544	.582
.30	.376	.408	.438	.467	.494	.520	.544	.567	.590	.610	.649
.35	.423	.457	.489	.520	.548	.575	.600	.624	.646	.667	.705
.40	.467	.502	.536	.567	.597	.624	.649	.673	.695	.715	.753
.45	.507	.544	.579	.610	.640	.667	.692	.715	.737	.757	.792
.50	.543	.582	.617	.649	.679	.705	.730	.753	.772	.792	.826
.55	.578	.617	.652	.684	.713	.739	.763	.785	.805	.822	.853
.60	.610	.649	.684	.715	.744	.769	.792	.813	.832	.848	.877
1.00	.792	.825	.853	.877	.897	.913	.927	.937	.947	.956	.969

The following table gives a comparison of the formulæ already given for the case of a belt one inch wide, with arc of contact 180°.

**Horse-power of a Belt One Inch wide, Arc of Contact 180°.**

COMPARISON OF DIFFERENT FORMULÆ.

Velocity in ft. per sec.	Velocity in ft. p. min.	Sq. ft. of Belt p. min.	Form. 1	Form. 2	Form. 3	Form. 4	Form. 5	Nagle's Form.	
			H.P. = $\frac{wv}{550}$	H.P. = $\frac{wv}{1100}$	H.P. = $\frac{wv}{1000}$	H.P. = $\frac{wv}{733}$	double belt H.P. = $\frac{wv}{513}$	7/32-in. single belt.	Laced.
10	600	50	1.09	0.55	0.60	0.82	1.17	0.73	1.14
20	1200	100	2.18	1.09	1.20	1.64	2.34	1.54	2.24
30	1800	150	3.27	1.64	1.80	2.46	3.51	2.25	3.31
40	2400	200	4.36	2.18	2.40	3.27	4.68	2.90	4.33
50	3000	250	5.45	2.73	3.00	4.09	5.85	3.48	5.26
60	3600	300	6.55	3.27	3.60	4.91	7.02	3.95	6.09
70	4200	350	7.63	3.82	4.20	5.73	8.19	4.29	6.78
80	4800	400	8.73	4.36	4.80	6.55	9.36	4.50	7.36
90	5400	450	9.82	4.91	5.40	7.37	10.53	4.55	7.74
100	6000	500	10.91	5.45	6.00	8.18	11.70	4.41	7.96
110	6600	550	.....	.....	.....	.....	.....	4.05	7.97
120	7200	600	.....	.....	.....	.....	.....	3.49	7.75

**Width of Belt for a Given Horse-power.**—The width of belt required for any given horse-power may be obtained by transposing the



formulae for horse-power so as to give the value of *w*. Thus:

From formula (1),  $w = \frac{550 \text{ H.P.}}{v} = \frac{9.17 \text{ H.P.}}{V} = \frac{2101 \text{ H.P.}}{d \times \text{r.p.m.}} = \frac{275 \text{ H.P.}}{L \times \text{r.p.m.}}$

From formula (2),  $w = \frac{1100 \text{ H.P.}}{v} = \frac{18.33 \text{ H.P.}}{V} = \frac{4202 \text{ H.P.}}{d \times \text{r.p.m.}} = \frac{530 \text{ H.P.}}{L \times \text{r.p.m.}}$

From formula (3),  $w = \frac{1000 \text{ H.P.}}{v} = \frac{16.67 \text{ H.P.}}{V} = \frac{3820 \text{ H.P.}}{d \times \text{r.p.m.}} = \frac{500 \text{ H.P.}}{L \times \text{r.p.m.}}$

From formula (4),  $w = \frac{733 \text{ H.P.}}{v} = \frac{12.22 \text{ H.P.}}{V} = \frac{2800 \text{ H.P.}}{d \times \text{r.p.m.}} = \frac{360 \text{ H.P.}}{L \times \text{r.p.m.}}$

From formula (5),\*  $w = \frac{513 \text{ H.P.}}{v} = \frac{8.56 \text{ H.P.}}{V} = \frac{1960 \text{ H.P.}}{d \times \text{r.p.m.}} = \frac{257 \text{ H.P.}}{L \times \text{r.p.m.}}$

Many authorities use formula (1) for double belts and formula (2) or (3) for single belts.

To obtain the width by Nagle's formula,  $w = \frac{550 \text{ H.P.}}{CVt(S - 0.012 V^2)}$ , or

divide the given horse-power by the figure in the table corresponding to the given thickness of belt and velocity in feet per second.

The formula to be used in any particular case is largely a matter of judgment. A single belt proportioned according to formula (1), if tightly stretched, and if the surface is in good condition, will transmit the horse-power calculated by the formula, but one so proportioned is objectionable, first, because it requires so great an initial tension that it is apt to stretch, slip, and require frequent restretching and relacing; and second, because this tension will cause an undue pressure on the pulley-shaft, and therefore an undue loss of power by friction. To avoid these difficulties, formula (2), (3), or (4), or Mr. Nagle's table, should be used; the latter especially in cases in which the velocity exceeds 4000 ft. per min.

The following are from the notes of the late Samuel Webber. (*Am. Mach.* May 11, 1909.)

Good oak-tanned leather from the back of the hide weighs almost exactly one avoirdupois ounce for each one-hundredth of an inch in thickness, in a piece of leather one foot square, so that

	Lbs. per Sq. Ft.	Approx. Thick-ness.	Actual Thick-ness.	Vel. per Inch for 1 H.P.	Safe Strain per Inch Width.
Single belt.....	16 oz.	1/8 in.	0.16 in.	625 ft.	52.8 lbs.
Light double.....	24 "	1/4 "	0.24 "	417 "	78.1 "
Medium.....	28 "	5/16 "	0.28 "	357 "	92.5 "
Standard.....	33 "	1/3 "	0.33 "	303 "	109 "
3-ply.....	45 "	9/16 "	0.45 "	222 "	148 "

The rule for velocity per inch width for 1 H.P. is:

Multiply the denominator of the fraction expressing the thickness of the belt in inches by 100, and divide it by the numerator;

Good, well-calendered rubber belting made with 30-ounce duck and new (i. e., not reclaimed vulcanized) rubber will be as follows:

Nomenclature.	Approximate Thickness.	Safe Working Strain for 1 Inch Width.	Velocity per Inch for 1 H.P.
3-ply	0.18 in.	45 pounds	735 ft. per min.
4 "	0.24 "	65 "	508 " " "
5 "	0.30 "	85 "	388 " " "
6 "	0.35 "	105 "	314 " " "
7 "	0.40 "	125 "	264 " " "
8 "	0.45 "	145 "	218 " " "

The thickness of rubber belt does not necessarily govern the strength, but the weight of duck does, and with 30-ounce duck, the safe working strains are as above.

**Belt Factors.** W. W. Bird (*Jour. Worcester Polyt. Inst.*, Jan. 1910.) — The factors given in the table below, for use in the formula  $H.P. = vw \div F$ , in which *F* is an empirical factor, are based on the following assumptions: A belt of single thickness will stand a stress on the tight

\* For double belts.

side,  $T_1$ , of 60 lbs. per inch of width, a double belt 105 lbs., and a triple belt 150 lbs., and have a fairly long life, requiring only occasional taking up; the ratio of tensions  $T_1/T_2$  should not exceed 2 on small, 2.5 on medium and 3 on large pulleys; the creep (travel of the belt relative to the surface of the pulley due to the elasticity of the belt and not to slip) should not exceed 1%—this requires that the difference in tensions  $T_1 - T_2$  should not be greater than 40 lbs. per inch of width for single, 70 for double and 100 for triple belts.

Pulley diam,	Under 8 in.	8 to 36 in.	Over 3 ft.	Under 14 in.	14 to 60 in.	Over 5 ft.	Under 21 in.	21 to 84 in.	Over 7 ft.
Belt thick-ness.	Single.	S'gle.	S'gle.	Dbl.	Dbl.	Dbl.	Triple.	Triple.	Triple.
Factor.....	1100	920	830	630	520	470	440	370	330
$T_1 - T_2$ .....	30	36	40	52.5	63	70	75	90	100
Creep, %....	0.74	0.89	0.99	0.74	0.89	0.99	0.74	0.89	0.99
$T_1 \div T_2$ ....	2	2.5	3	2	2.5	3	2	2.5	3
$T_1$ .....	60	60	60	105	105	105	150	150	150

These factors are for an arc of contact of 180°. For other arcs they are to be multiplied by the figures given below.

Arc.....	220°	210°	200°	190°	170°	160°	150°	140°	130°	120°
Multiplied by...	0.89	0.92	0.95	0.97	1.04	1.07	1.11	1.16	1.21	1.27

**Taylor's Rules for Belting.**—F. W. Taylor (*Trans. A. S. M. E.*, xv, 204) describes a nine years' experiment on belting in a machine shop, giving results of tests of 42 belts running night and day. Some of these belts were run on cone pulleys and others on shifting, or fast-and-loose, pulleys. The average net working load on the shifting belts was only 0.4 of that of the cone belts.

The shifting belts varied in dimensions from 39 ft. 7 in. long, 3.5 in. wide, 0.25 in. thick, to 51 ft. 5 in. long, 6.5 in. wide, 0.37 in. thick. The cone belts varied in dimensions from 24 ft. 7 in. long, 2 in. wide, 0.25 in. thick, to 31 ft. 10 in. long, 4 in. wide, 0.37 in. thick.

Belt-clamps were used having spring-balances between the two pairs of clamps, so that the exact tension to which the belt was subjected was accurately weighed when the belt was first put on, and each time it was tightened. The tension under which each belt was spliced was carefully figured so as to place it under an initial strain—while the belt was at rest immediately after tightening—of 71 lbs. per inch of width of double belts. This is equivalent, in the case of

- Oak tanned and fulled belts, to 192 lbs. per sq. in. section;
- Oak tanned, not fulled belts, to 229 " " " " "
- Semi-raw-hide belts, to 253 " " " " "
- Raw-hide belts to 284 " " " " "

From the nine years experiment Mr. Taylor draws a number of conclusions, some of which are given in an abridged form below.

In using belting so as to obtain the greatest economy and the most satisfactory results, the following rules should be observed:

	Oak Tanned and Fulled Leather Belts.	Other Types of Leather Belts and 6- to 7-ply Rubber Belts.
A double belt, having an arc of contact of 180°, will give an effective pull on the face of a pulley per inch of width of belt of.....	35 lbs.	30 lbs.
Or, a different form of same rule: The number of sq. ft. of double belt passing around a pulley per minute required to transmit one horse-power is.....	80 sq. ft.	90 sq. ft.
Or: The number of lineal feet of double belting 1 in. wide passing around a pulley per minute required to transmit one horse-power is.....	950 ft.	1100 ft.
Or: A double belt 6 in. wide, running 4000 to 5000 ft. per min., will transmit.....	30 H.P.	25 H.P.

The terms "initial tension," "effective pull," etc., are thus explained by Mr. Taylor: When pulleys upon which belts are tightened are at rest both strands of the belt (the upper and lower) are under the same stress per in. of width. By "tension," "initial tension," or "tension while at rest," we mean the stress per in. of width, or sq. in. of section, to which one of the strands of the belt is tightened, when at rest. After the belts are in motion and transmitting power, the stress on the slack side, or strand, of the belt becomes less, while that on the tight side — or the side which does the pulling — becomes greater than when the belt was at rest. By the term "total load" we mean the total stress per in. of width, or sq. in. of section, on the tight side of belt while in motion.

The difference between the stress on the tight side of the belt and its slack side, while in motion, represents the effective force or pull which is transmitted from one pulley to another. By the terms "working load," "net working load," or "effective pull," we mean the difference in the tension of the tight and slack sides of the belt per in. of width, or sq. in. section, while in motion, or the net effective force that is transmitted from one pulley to another per in. of width or sq. in. of section.

The discovery of Messrs. Lewis and Bancroft (*Trans. A. S. M. E.*, vii, 549) that the "sum of the tension on both sides of the belt does not remain constant," upsets all previous theoretical belting formulæ.

The belt speed for maximum economy should be from 4000 to 4500 ft. per minute.

The best distance from center to center of shafts is from 20 to 25 ft.

Idler pulleys work most satisfactorily when located on the slack side of the belt about one-quarter way from the driving-pulley.

Belts are more durable and work more satisfactorily made narrow and thick, rather than wide and thin.

It is safe and advisable to use: a double belt on a pulley 12 in. diameter or larger; a triple belt on a pulley 20 in. diameter or larger; a quadruple belt on a pulley 30 in. diameter or larger.

As belts increase in width they should also be made thicker.

The ends of the belt should be fastened together by splicing and cementing, instead of lacing, wiring, or using hooks or clamps of any kind.

A V-splice should be used on triple and quadruple belts and when idlers are used. Stepped splice, coated with rubber and vulcanized in place, is best for rubber belts.

For double belting the rule works well of making the splice for all belts up to 10 in. wide, 10 in. long; from 10 in. to 18 in. wide the splice should be the same width as the belt, 18 in. being the greatest length of splice required for double belting.

Belts should be cleaned and greased every five to six months.

Double leather belts will last well when repeatedly tightened under a strain (when at rest) of 71 lbs. per in. of width, or 240 lbs. per sq. in. section, but they will not maintain this tension for any length of time.

Belt-clamps having spring-balances between the pairs of clamps should be used for weighing the tension of the belt each time it is tightened.

The stretch, durability, cost of maintenance, etc., of belts proportioned (A) according to the ordinary rules of a total load of 111 lbs. per inch of width, corresponding to an effective pull of 65 lbs. per inch of width, and (B) according to a more economical rule of a total load of 54 lbs., corresponding to an effective pull of 26 lbs. per inch of width, are found to be as follows:

When it is impracticable to accurately weigh the tension of a belt in tightening it, it is safe to shorten a double belt one-half inch for every 10 ft. of length for (A) and one inch for every 10 ft. for (B), if it requires tightening.

Double leather belts, when treated with great care and run night and day at moderate speed, should last for 7 years (A); 18 years (B).

The cost of all labor and materials used in the maintenance and repairs of double belts, added to the cost of renewals as they give out, through a term of years, will amount on an average per year to 37% of the original cost of the belts (A); 14% or less (B).

In figuring the total expense of belting, and the manufacturing cost chargeable to this account, by far the largest item is the time lost on the machines while belts are being relaced and repaired.

The total stretch of leather belting exceeds 6% of the original length.



The stretch during the first six months of the life of belts is 36% of their entire stretch (A); 15% (B).

A double belt will stretch 0.47% of its length before requiring to be tightened (A); 0.81% (B).

The most important consideration in making up tables and rules for the use and care of belting is how to secure the minimum of interruptions to manufacture from this source.

The average double belt (A), when running night and day in a machine-shop, will cause at least 26 interruptions to manufacture during its life, or 5 interruptions per year, but with (B) interruptions to manufacture will not average oftener for each belt than one in sixteen months.

The oak-tanned and fulled belts showed themselves to be superior in all respects except the coefficient of friction to either the oak-tanned not fulled, the semi-raw-hide, or raw-hide with tanned face.

Belts of any width can be successfully shifted backward and forward on tight and loose pulleys. Belts running between 5000 and 6000 ft. per min. and driving 300 H.P. are now being daily shifted on tight and loose pulleys, to throw lines of shafting in and out of use.

The best form of belt-shifter for wide belts is a pair of rollers twice the width of belt, either of which can be pressed onto the flat surface of the belt on its slack side close to the driven pulley, the axis of the roller making an angle of 75° with the center line of the belt.

**Remarks on Mr. Taylor's Rules.** (W. Kent, *Trans. A. S. M. E.*, xv, 242.)—The most notable feature in Mr. Taylor's paper is the great difference between his rules for proper proportioning of belts and those given by earlier writers. A very commonly used rule is, one horse-power may be transmitted by a single belt 1 in. wide running  $x$  ft. per min., substituting for  $x$  various values, according to the ideas of different engineers, ranging usually from 550 to 1100.

The practical mechanic of the old school is apt to swear by the figure 600 as being thoroughly reliable, while the modern engineer is more apt to use the figure 1000. Mr. Taylor, however, instead of using a figure from 550 to 1100 for a single belt, uses 950 to 1100 for double belts. If we assume that a double belt is twice as strong, or will carry twice as much power, as a single belt, then he uses a figure at least twice as large as that used in modern practice, and would make the cost of belting for a given shop twice as large as if the belting were proportioned according to the most liberal of the customary rules.

This great difference is to some extent explained by the fact that the problem which Mr. Taylor undertakes to solve is quite a different one from that which is solved by the ordinary rules with their variations. The problem of the latter generally is, "How wide a belt must be used, or how narrow a belt may be used, to transmit a given horse-power?" Mr. Taylor's problem is: "How wide a belt must be used so that a given horse-power may be transmitted with the minimum cost for belt repairs, the longest life to the belt, and the smallest loss and inconvenience from stopping the machine while the belt is being tightened or repaired?"

The difference between the old practical mechanic's rule of a 1-in.-wide single belt, 600 ft. per min., transmits one horse-power, and the rule commonly used by engineers, in which 1000 is substituted for 600, is due to the belief of the engineers, not that a horse-power could not be transmitted by the belt proportioned by the older rule, but that such a proportion involved undue strain from overtightening to prevent slipping, which strain entailed too much journal friction, necessitated frequent tightening, and decreased the length of the life of the belt.

Mr. Taylor's rule substituting 1100 ft. per min. and doubling the belt, is a further step, and a long one, in the same direction. Whether it will be taken in any case by engineers will depend upon whether they appreciate the extent of the losses due to slippage of belts slackened by use under overstrain, and the loss of time in tightening and repairing belts, to such a degree as to induce them to allow the first cost of the belts to be doubled in order to avoid these losses.

It should be noted that Mr. Taylor's experiments were made on rather narrow belts, used for transmitting power from shafting to machinery, and his conclusions may not be applicable to heavy and wide belts, such as engine fly-wheel belts.

**Barth's Studies on Belting.** (*Trans. A. S. M. E.*, 1909.)—Mr. Carl G. Barth has made an extensive study of the work of earlier writers on the subject of belting, and has derived several new formulæ and diagrams showing the relation of the several variables that enter into the belt problem. He has also devised a slide rule by which calculations of belts may easily be made. He finds that the coefficient of friction depends on the velocity of the belt, and may be expressed by the formula

$$f = 0.54 - \frac{140}{500 + V},$$

in which  $V$  is the velocity in feet per minute.

Taking Mr. Taylor's data as a starting point, Mr Barth has adopted the rule, as a basis for use of belts on belt-driven machines, that for the driving belt of a machine the *minimum initial tension* must be such that when the belt is doing the maximum amount of work intended, the *sum of the tension in the tight side of the belt and one-half the tension in the slack side will equal 240 lbs. per square inch of cross-section for all belt speeds*; and that for a belt driving a countershaft, or any other belt inconvenient to get at for retightening or more readily made of liberal dimensions, this sum will equal 160 lbs. Further, the maximum initial tension, that is, the initial tension under which a belt is to be put up in the first place, and to which it is to be retightened as often as it drops to the minimum, must be such that the sum defined above is 320 lbs. for a machine belt, and 240 lbs. for a counter-shaft belt or a belt similarly circumstanced.

From a set of curves plotted by Mr. Barth from his formula the following tables are derived. The figures are based upon the conditions named in the above rule, and on an arc of contact = 180°.

Belts on Machines. Tension in tight side + 1/2 tension in slack side = 240 lbs.

Velocity, ft. per min...	500	1000	2000	3000	4000	5000	6000
Initial tension, $t_0$ . . . . .	124	120	121	128	136	144	152
Centrifugal tension $t_c$ . . . . .	0 +	3	13	31	56	86	124
Difference, $t_0 - t_c$ . . . . .	123	117	108	97	80	58	28
Tension on tight side, $t_1$ . . . . .	210	212	211	207	198	187	173
Tension on slack side, $t_2$ . . . . .	60	54	57	68	84	107	134
Effective pull, $t_1 - t_2$ . . . . .	150	158	154	139	114	80	39
Sum of tensions $t_1 + t_2$ . . . . .	270	268	269	274	282	294	307
H.P. per sq. in. of section . . . . .	2.27	4.79	9.33	12.64	13.82	12.12	7.09
H.P. per in. width, $\frac{5}{16}$ in. thick . . . . .	0.71	1.50	2.82	3.95	4.32	3.71	2.22

Belts driving countershafts,  $t_1 + \frac{1}{2} t_2 = 160$  lbs.

Velocity of belt, ft. per min. . . . .	500	1000	2000	3000	4000	5000
Initial tension, $t_0$ . . . . .	82	81	83	89	96	102
Tension on tight side, $t_1$ . . . . .	140	141	140	134	125	114
Tension on slack side, $t_2$ . . . . .	40	38	41	53	69	92
Effective pull, $t_1 - t_2$ . . . . .	100	103	99	81	56	22
Sum of tensions . . . . .	180	179	181	187	194	206
H.P. per sq. in. of section . . . . .	1.51	3.12	6.04	7.36	6.79	3.33
H.P. per in. width, $\frac{5}{16}$ in. thick . . . . .	0.47	0.97	1.87	2.30	2.12	1.04

**MISCELLANEOUS NOTES ON BELTING.**

Formulæ are useful for proportioning belts and pulleys, but they furnish no means of estimating how much power a particular belt may be transmitting at any given time, any more than the size of the engine is a measure of the load it is actually drawing, or the known strength of a horse is a measure of the load on the wagon. The only reliable means of determining the power actually transmitted is some form of dynamometer. (See *Trans. A. S. M. E.*, vol. xii, p. 707.)

If we increase the thickness, the power transmitted ought to increase in proportion; and for double belts we should have half the width required for a single belt under the same conditions. With large pulleys and moderate velocities of belt it is probable that this holds good. With small pulleys, however, when a double belt is used, there is not such per-

fect contact between the pulley-face and the belt, due to the rigidity of the latter, and more work is necessary to bend the belt-fibers than when a thinner and more pliable belt is used. The centrifugal force tending to throw the belt from the pulley also increases with the thickness, and for these reasons the width of a double belt required to transmit a given horse-power when used with small pulleys is generally assumed not less than seven-tenths the width of a single belt to transmit the same power. (Flather on "Dynamometers and Measurement of Power.")

F. W. Taylor, however, finds that great pliability is objectionable, and favors thick belts even for small pulleys. The power consumed in bending the belt around the pulley he considers inappreciable. According to Rankine's formula for centrifugal tension, this tension is proportional to the sectional area of the belt, and hence it does not increase with increase of thickness when the width is decreased in the same proportion, the sectional area remaining constant.

Scott A. Smith (*Trans. A. S. M. E.*, x, 765) says: The best belts are made from all oak-tanned leather, and curried with the use of cod oil and tallow, all to be of superior quality. Such belts have continued in use thirty to forty years when used as simple driving-belts, driving a proper amount of power, and having had suitable care. The flesh side should not be run to the pulley-face, for the reason that the wear from contact with the pulley should come on the grain side, as that surface of the belt is much weaker in its tensile strength than the flesh side; also as the grain is hard it is more enduring for the wear of attrition; further, if the grain is actually worn off, then the belt may not suffer in its integrity from a ready tendency of the hard grain side to crack.

The most intimate contact of a belt with a pulley comes, first, in the smoothness of a pulley-face, including freedom from ridges and hollows left by turning-tools; second, in the smoothness of the surface and evenness in the texture or body of a belt; third, in having the crown of the driving and receiving pulleys exactly alike, — as nearly so as is practicable in a commercial sense; fourth, in having the crown of pulleys not over  $\frac{1}{8}$  in. for a 24-in. face, that is to say, that the pulley is not to be over  $\frac{1}{4}$  in. larger in diameter in its center; fifth, in having the crown other than two planes meeting at the center; sixth, the use of any material on or in a belt, in addition to those necessarily used in the currying process, to keep them pliable or increase their tractive quality, should wholly depend upon the exigencies arising in the use of belts; non-use is safer than over-use; seventh, with reference to the lacing of belts, it seems to be a good practice to cut the ends to a convex shape by using a former, so that there may be a nearly uniform stress on the lacing through the center as compared with the edges. For a belt 10 ins. wide, the center of each end should recede  $\frac{1}{10}$  in.

**Lacing of Belts.** — In punching a belt for lacing, use an oval punch, the longer diameter of the punch being parallel with the sides of the belt. Punch two rows of holes in each end, placed zigzag. In a 3-in. belt there should be four holes in each end — two in each row. In a 6-in. belt, seven holes — four in the row nearest the end. A 10-in. belt should have nine holes. The edge of the holes should not come nearer than  $\frac{3}{4}$  in. from the sides, nor  $\frac{7}{8}$  in. from the ends of the belt. The second row should be at least  $1\frac{3}{4}$  ins. from the end. On wide belts these distances should be even a little greater.

Begin to lace in the center of the belt and take care to keep the ends exactly in line, and to lace both sides with equal tightness. The lacing should not be crossed on the side of the belt that runs next the pulley. In taking up belts, observe the same rules as in putting on new ones.

**Setting a Belt on Quarter-twist.** — A belt must run squarely on to the pulley. To connect with a belt two horizontal shafts at right angles with each other, say an engine-shaft near the floor with a line attached to the ceiling, will require a quarter-turn. First, ascertain the central point on the face of each pulley at the extremity of the horizontal diameter where the belt will leave the pulley, and then set that point on the driven pulley plumb over the corresponding point on the driver. This will cause the belt to run squarely on to each pulley, and it will leave at an angle greater or less, according to the size of the pulleys and their distance from each other.

In quarter-twist belts, in order that the belt may remain on the pulleys,



the central plane on each pulley must pass through the point of delivery of the other pulley. This arrangement does not admit of reversed motion.

**To find the Length of Belt required for two given Pulleys.** — When the length cannot be measured directly by a tape-line, the following approximate rule may be used: Add the diameter of the two pulleys together, divide the sum by 2, and multiply the quotient by  $3\frac{1}{4}$ , and add the product to twice the distance between the centers of the shafts. (See accurate formula below.)

**To find the Angle of the Arc of Contact of a Belt.** — Divide the difference between the radii of the two pulleys in inches by the distance between their centers, also in inches, and in a table of natural sines find the angle most nearly corresponding with the quotient. Multiply this angle by 2, and add the product to  $180^\circ$  for the angle of contact with the larger pulley, or subtract it from  $180^\circ$  for the smaller pulley.

Or, let  $R$  = radius of larger pulley,  $r$  = radius of smaller;

$L$  = distance between centers of the pulleys;

$a$  = angle whose sine is  $(R - r) \div L$ .

Arc of contact with smaller pulley =  $180^\circ - 2a$ ;

Arc of contact with larger pulley =  $180^\circ + 2a$ .

**To find the Length of Belt in Contact with the Pulley.** — For the larger pulley, multiply the angle  $a$ , found as above, by 0.0349, to the product add 3.1416, and multiply the sum by the radius of the pulley. Or length of belt in contact with the pulley

$$= \text{radius} \times (\pi + 0.0349 a) = \text{radius} \times \pi(1 + a/90).$$

For the smaller pulley, length = radius  $\times (\pi - 0.0349 a)$

$$= \text{radius} \times \pi(1 - a) \div 90.$$

The above rules refer to **Open Belts**. The accurate formula for length of an open belt is,

$$\text{Length} = \pi R(1 + a/90) + \pi r(1 - a/90) + 2L \cos a.$$

$$= R(\pi + 0.0349 a) + r(\pi - 0.0349 a) + 2L \cos a,$$

in which  $R$  = radius of larger pulley,  $r$  = radius of smaller pulley,

$L$  = distance between centers of pulleys, and  $a$  = angle whose sine is

$$(R - r) \div L; \cos a = \sqrt{L^2 - (R - r)^2} \div L.$$

An approximate formula is

$$\text{Length} = 2L + \pi(R + r) + (R - r)^2/L$$

For  $L = 4$ ,  $R = 2$ ,  $r = 1$ , this formula gives length = 17.6748, the accurate formula giving 17.6761

**For Crossed Belts** the formula is

$$\text{Length of belt} = \pi R(1 + \beta/90) + \pi r(1 + \beta/90) + 2L \cos \beta$$

$$= (R + r) \times (\pi + 0.0349 \beta) + 2L \cos \beta,$$

In which  $\beta$  = angle whose sine is  $(R + r) \div L$ ;  $\cos \beta = \sqrt{L^2 - (R + r)^2} \div L$ .

**To find the Length of Belt when Closely Rolled.** — The sum of the diameter of the roll, and of the eye in inches,  $\times$  the number of turns made by the belt and by 0.1309, = length of the belt in feet.

**To find the Approximate Weight of Belts.** — Multiply the length of belt, in feet; by the width in inches, and divide the product by 13 for single and 8 for double belt.

Good oak-tanned leather from the back of the hide weighs almost exactly 1 oz. per sq. ft. per 0.01 in. thickness. The thickness of single belts is 0.16 in.; of light double belts, 0.24 in.; of medium weight double belt, 0.28 in.; of standard double belt, 0.33 in.; of 3-ply belts, 0.45 in. (W. O. Webber, in *Trans. Natl. Assoc. Cotton Mfrs.*, 1908, p. 345.)

**Relations of the Size and Speeds of Driving and Driven Pulleys.** — The driving pulley is called the driver,  $D$ , and the driven pulley the driven,  $d$ . If the number of teeth in gears is used instead of diameter, in these calculations, number of teeth must be substituted wherever diameter occurs.  $R$  = revs. per min. of driver,  $r$  = revs. per min. of driven.

$$D = dr \div R;$$

Diam. of driver = diam. of driven  $\times$  revs. of driven  $\div$  revs. of driver.

$$d = DR \div r;$$

Diam. of driven = diam. of driver  $\times$  revs. of driver  $\div$  revs. of driven.

$$R = dr \div D;$$

Revs. of driver = revs. of driven  $\times$  diam. of driven  $\div$  diam. of driver.

$$r = DR \div d;$$

Revs. of driven = revs. of driver  $\times$  diam. of driver  $\div$  diam. of driven.

**Evils of Tight Belts.** (Jones and Laughlins.) — Clamps with powerful screws are often used to put on belts with extreme tightness, and with most injurious strain upon the leather. They should be very judiciously used for horizontal belts, which should be allowed sufficient slackness to move with a loose undulating vibration on the returning side, as a test that they have no more strain imposed than is necessary simply to transmit the power.

On this subject a New England cotton-mill engineer of large experience says: I believe that three-quarters of the trouble experienced in broken pulleys, hot boxes, etc., can be traced to the fault of tight belts. The enormous and useless pressure thus put upon pulleys must in time break them, if they are made in any reasonable proportions, besides wearing out the whole outfit, and causing heating and consequent destruction of the bearings. Below are figures showing the power taken, in average modern mills with first-class shafting, to drive the shafting alone:

Mill No.	Whole Load, H.P.	Shafting Alone.		Mill No.	Whole Load, H.P.	Shafting Alone.	
		Horse-power.	Per cent. of whole.			Horse-power.	Per cent. of whole.
1	199	51	25.6	5	759	172.6	22.7
2	472	111.5	23.6	6	235	84.8	36.1
3	486	134	27.5	7	670	262.9	39.2
4	677	190	28.1	8	677	182	26.8

These may be taken as a fair showing of the power that is required in many of our best mills to drive shafting. It is unreasonable to think that all that power is consumed by a legitimate amount of friction of bearings and belts. I know of no cause for such a loss of power but tight belts. These, when there are hundreds or thousands in a mill, easily multiply the friction on the bearings, and would account for the figures.

**Sag of Belts. Distance between Pulleys.** — In the location of shafts that are to be connected with each other by belts, care should be taken to secure a proper distance one from the other. This distance should be such as to allow of a gentle sag to the belt when in motion.

A general rule may be stated thus: Where narrow belts are to be run over small pulleys 15 feet is a good average, the belt having a sag of  $1\frac{1}{2}$  to 2 inches.

For larger belts, working on larger pulleys, a distance of 20 to 25 feet does well, with a sag of  $2\frac{1}{2}$  to 4 inches.

For main belts working on very large pulleys, the distance should be 25 to 30 feet, the belts working well with a sag of 4 to 5 inches.

If too great a distance is attempted, the belt will have an unsteady flapping motion, which will destroy both the belt and machinery.

**Arrangement of Belts and Pulleys.** — If possible to avoid it, connected shafts should never be placed one directly over the other, as in such case the belt must be kept very tight to do the work. For this purpose belts should be carefully selected of well-stretched leather.

It is desirable that the angle of the belt with the floor should not exceed  $45^\circ$ . It is also desirable to locate the shafting and machinery so that belts should run off from each shaft in opposite directions, as this arrangement will relieve the bearings from the friction that would result when the belts all pull one way on the shaft.

In arranging the belts leading from the main line of shafting to the counters, those pulling in an opposite direction should be placed as near each other as practicable, while those pulling in the same direction should be separated. This can often be accomplished by changing the relative positions of the pulleys on the counters. By this procedure much of the friction on the journals may be avoided.

If possible, machinery should be so placed that the direction of the belt

motion shall be from the top of the driving to the top of the driven pulley, when the sag will increase the arc of contact.

The pulley should be a little wider than the belt required for the work. The motion of driving should run with the laps of the belts.

Tightening or guide pulleys should be applied to the slack side of belts and near the smaller pulley.

Jones and Laughlins, in their Useful Information, say: The diameter of the pulleys should be as large as can be admitted, provided they will not produce a speed of more than 4750 feet of belt motion per minute.

They also say: It is better to gear a mill with small pulleys and run them at a high velocity, than with large pulleys and to run them slower. A mill thus geared costs less and has a much neater appearance than with large heavy pulleys.

M. Arthur Achard (*Proc. Inst. M. E.*, Jan., 1881, p. 62) says: When the belt is wide a partial vacuum is formed between the belt and the pulley at a high velocity. The pressure is then greater than that computed from the tensions in the belt, and the resistance to slipping is greater. This has the advantage of permitting a greater power to be transmitted by a given belt, and of diminishing the strain on the shafting.

On the other hand, some writers claim that the belt entraps air between itself and the pulley, which tends to diminish the friction, and reduce the tractive force. On this theory some manufacturers perforate the belt with numerous holes to let the air escape.

**Care of Belts.** — Leather belts should be well protected against water, loose steam, and all other moisture, with which they should not come in contact. But where such conditions prevail fairly good results are obtained by using a special dressing prepared for the purpose of water-proofing leather, though a positive water-proofing material has not yet been discovered.

Belts made of coarse, loose-fibered leather will do better service in dry and warm places, but if damp or moist conditions exist then the very finest and firmest leather should be used. (Fayerweather & Ladew.)

Do not allow oil to drip upon the belts. It destroys the life of the leather. Leather belting cannot safely stand above 130° of heat.

"Duxbak" waterproof belt is advertised to withstand any amount of moisture, and temperatures up to 200 degrees.

**Strength of Belting.**—The ultimate tensile strength of belting does not generally enter as a factor in calculations of power transmission.

The strength of the solid leather in belts is from 2000 to 5000 lbs. per square inch; at the lacings, even if well put together, only about 1000 to 1500. If riveted, the joint should have half the strength of the solid belt. The working strain on the driving side is generally taken at not over one-third of the strength of the lacing, or from one-eighth to one-sixteenth of the strength of the solid belt. Dr. Hartig found that the tension in practice varied from 30 to 532 lbs. per sq. in., averaging 273 lbs.

**Effect of Humidity Upon a Leather Belt.** (W. W. Bird and F. W. Roys, *Trans. A. S. M. E.*, 1915.)—Tests with a 4-in. oak-tanned single belt, with constant horse-power transmitted, and with the center distance and humidity varying, showed increase of the sum of the tensions as the humidity decreased, figures taken from curves of the results being as follows:

Center distance:	9 ft. 6 in.,	9 ft. 6½ in.,	9 ft. 7 in.,	9 ft. 7½ in.
Relative Humidity.	Sum of the Tensions, pounds.			
90.....	95	210	325	445
55.....	125	260	400	550
20.....	150	310	465	620

Increase of temperature as well as increase of humidity tends to lengthen the belt and decrease the tension. The most important conclusions are:

1. If a belt be set up at a medium relative humidity, the tensions will not be excessive at lower relative humidities, nor will there be any great danger of slipping at high relative humidities unless there are excessive temperature changes.

2. If a belt be set up at any relative humidity with a spring or gravity tightener, a load 50 per cent greater than the standard can be transmitted at either high or low humidity without danger of stretching the belt, slipping, or excessive pressure on the bearings.



**Adhesion Independent of Diameter.** (Schultz Belting Co.) —

1. The adhesion of the belt to the pulley is the same — the arc or number of degrees of contact, aggregate tension or weight being the same — without reference to width of belt or diameter of pulley.

2. A belt will slip just as readily on a pulley four feet in diameter as it will on a pulley two feet in diameter, provided the conditions of the faces of the pulleys, the arc of contact, the tension, and the number of feet the belt travels per minute are the same in both cases.

3. To obtain a greater amount of power from belts the pulleys may be covered with leather; this will allow the belts to run very slack and give 25% more durability.

**Endless Belts.** — If the belts are to be endless, they should be put on and drawn together by "belt clamps" made for the purpose. If the belt is made endless at the belt factory, it should never be run on to the pulleys, lest the irregular strain spring the belt. Lift out one shaft, place the belt on the pulleys, and force the shaft back into place.

**Belt Data.** — A fly-wheel at the Amoskeag Mfg. Co., Manchester, N.H., 30 feet diameter, 110 inches face, running 61 revs. per min., carried two heavy double-leather belts 40 inches wide each, and one 24 inches wide. The engine indicated 1950 H.P., of which probably 1850 H.P. was transmitted by the belts. The belts were heavily loaded, but not overtaxed, the speed being 323 ft. per min. for 1 H.P. per inch of width.

Samuel Webber (*Am. Mach.*, Feb. 22, 1894) reports a case of a belt 30 ins. wide,  $\frac{3}{8}$  in. thick, running for six years at a velocity of 3900 ft. per min., on to a pulley 5 ft. diameter, and transmitting 556 H.P. This gives a velocity of 210 ft. per min. for 1 H.P. per in. of width. By Mr. Nagle's table of riveted belts this belt would be designed for 332 H.P. By Mr. Taylor's rule it would be used to transmit only 123 H.P.

The above may be taken as examples of what a belt may be made to do, but they should not be used as precedents in designing. It is not stated how much power was lost by the journal friction due to over-tightening of these belts.

**The United States Navy Department Specifications for Leather Belting.**—Belting to be cut from No. 1 native packer steer hides or their equal. All hides to be tanned with white or chestnut oak by slow process (six to eight months) and chemical processes must not be used. The leather is to be thoroughly cured by hand and must not be stuffed or loaded for artificial weight. Leather must not crack open on grain side when doubled strongly by hand with grain side out. Belting is to be cut from central part of the hide no further than 15 in. from backbone or more than 48 in. from tail toward shoulder.

Belts 8 in. and over must be cut to include backbone. All leather is to be stretched 6 in. in lengthwise direction of the butt and is not to exceed 54 in. after stretching. Centers and sides are to be stretched 6 in. separately. That is, all side leathers from which widths under 8 in. are to be cut, must be stretched after the belting is removed from the backbone center section. Center sections are to be stretched in exactly the same size for which they are to be used.

For single belts up to 6 in., laps must not exceed 6 in. nor be less than  $3\frac{1}{2}$  in. long. For single belts over 6 in. laps must not be more than 1 in. wider than belt.

For double belts, laps must not exceed  $5\frac{1}{2}$  in. nor to be less than  $3\frac{1}{2}$  in. No filling straps will be permitted. All laps must be held securely at every part with the best quality of belt cement, and when pulled apart shall show no resinous, vitreous, oily or watered condition. Belting is to be stretched again after manufacture.

Belting is to weigh for all sizes of single belts 16 oz. per sq. ft. and for double belts per sq. ft. as follows: 1 to 2 in., 26 oz.;  $2\frac{1}{2}$  to 4 in., 28 oz.;  $4\frac{1}{2}$  to 5 in., 30 oz.; 6 in. and over, 32 oz.

Only hand cut, green slaughter hides of the best quality are to be used for lacing. Raw hide laces to be cut  $\frac{1}{4}$ ,  $\frac{5}{16}$ ,  $\frac{3}{8}$ ,  $\frac{7}{16}$ ,  $\frac{1}{2}$ ,  $\frac{5}{8}$ , and  $\frac{3}{4}$ -in. sizes. They must be cut lengthwise from the hide and have an ultimate tensile strength of not less than

Width, in. . . . .	$\frac{1}{4}$	$\frac{5}{16}$	$\frac{3}{8}$	$\frac{7}{16}$	$\frac{1}{2}$	$\frac{5}{8}$	$\frac{3}{4}$
Tensile strength, lb. . . . .	95	125	155	165	180	205	230

**Belt Dressings.**—We advise that no belt dressing should be used except when the belt becomes dry and husky, and in such instances we

recommend the use of a dressing. Where this is not used beef tallow at blood-warm temperature should be applied and then dried in, either by artificial heat or the sun. The addition of beeswax to the tallow will be of some service if the belts are used in wet or damp places. Resin should never be used on leather belting. (Fayerweather & Ladew.)

Belts should not be soaked in water before oiling, and penetrating oils should only be used when a belt gets very dry and husky from neglect. It may then be moistened a little, and neatsfoot oil applied. Frequent applications of such oils to a new belt render the leather soft and flabby, thus causing it to stretch, and making it liable to run out of line. A composition of tallow and oil, with a little resin or beeswax, is better to use. Prepared castor-oil dressing is good, and may be applied with a brush or rag while the belt is running. (Alexander Bros.)

Some forms of belt dressing, the compositions of which have not been published, appear to have the property of increasing the coefficient of friction between the belt and the pulley, enabling a given power to be transmitted with a lower belt tension than with undressed belts. C. W. Evans (*Power*, Dec., 1905), gives a diagram, plotted from tests, which shows that three of these compositions gave increased transmission for a given tension, ranging from about 10% for 90 lbs. tension per inch of width to 100% increase with 20 lbs. tension.

**Cement for Cloth or Leather.** (Molesworth.)—16 parts gutta-percha, 4 india-rubber, 2 pitch, 1 shellac, 2 linseed-oil, cut small, melted together and well mixed.

**Rubber Belting.**—The advantages claimed for rubber belting are perfect uniformity in width and thickness; it will endure a great degree of heat and cold without injury; it is also specially adapted for use in damp or wet places, or where exposed to the action of steam; it is very durable, and has great tensile strength, and when adjusted for service it has the most perfect hold on the pulleys, hence is less liable to slip than leather.

*Never use animal oil or grease on rubber belts, as it will soon destroy them.*

Rubber belts will be improved, and their durability increased, by putting on with a painter's brush, and letting it dry, a composition made of equal parts of red lead, black lead, French yellow, and litharge, mixed with boiled linseed-oil and japan enough to make it dry quickly. The effect of this will be to produce a finely polished surface. If, from dust or other cause, the belt should slip, it should be lightly moistened on the pulley side with boiled linseed-oil. (From manufacturers' circulars.)

The best conditions are large pulleys and high speeds, low tension and reduced width of belt. 4000 ft. per min. is not an excessive speed on proper sized pulleys.

H.P. of a 4-ply rubber belt = (length of arc of contact on smaller pulley in ft.  $\times$  width of belt in ins.  $\times$  revs. per min.)  $\div$  325. For a 5-ply belt multiply by  $1\frac{1}{3}$ , for a 6-ply by  $1\frac{2}{3}$ , for a 7-ply by 2, for an 8-ply by  $2\frac{1}{3}$ . When the proper weight of duck is used a 3- or 4-ply rubber belt is equal to a single leather belt and a 5- or 6-ply rubber to a double leather belt. When the arc of contact is  $180^\circ$ , H.P. of a 4-ply belt = width in ins.  $\times$  velocity in ft. per min.  $\div$  650. (Boston Belting Co.)

**Steel Belts.**—The Eloesser-Kraftband-Gesellschaft, of Berlin, has introduced a steel belt for heavy power transmission at high speeds (*Am. Mach.*, Dec. 24, 1908). It is a thin flat band of tempered steel. The ends are soldered and then clamped by a special device consisting of two steel plates, tapered to thin edges, which are curved to the radius of the smallest pulley to be used, and joined together by small screws which pass through holes in the ends of the belt. It is stated that the slip of these belts is less than 0.1%; they are about one-fifth the width of a leather belt for the same power, and they are run at a speed of 10,000 ft. per minute or upwards. The following figures give a comparison of a rope drive with six ropes 1.9 ins. diam., a leather belt 9.6 ins. wide and a steel belt 4 ins. wide, for transmitting 100 H.P. on pulleys 3 ft. diam. 30 ft. apart at 200 r.p.m.

	Rope Drive.	Leather Belt.	Steel Belt.
Weight of pulley, lbs. . . . .	2200	1120	460
Weight of rope or belt, lbs. . . . .	530	240	30
Total cost of drive . . . . .	\$335	\$425	\$250
Power lost, per cent of 100 H.P. . . . .	13	6	0.5

**ROLLER CHAIN AND SPROCKET DRIVES.**

The following is abstracted from an article by A. E. Michel, in *Mach'y*, Feb., 1905. (Revised, March, 1915.)

Steel chain of accurate pitch, high tensile strength, and good wearing qualities, possesses, when used within proper limitations, advantages enjoyed by no other form of transmission. It is compact, affords a positive speed ratio, and at slow speeds is capable of transmitting heavy strains. On short transmissions it is more efficient than belting and will operate more satisfactorily in damp or oily places. There is no loss of power from stretch, and as it allows of a low tension, journal friction is minimized.

Roller chain has been known to stand up at a speed of 4,000 ft. per min., and transmit 25 H.P. at 1,250 ft. per min.; but speeds of 1,000 ft. per min. and under give better satisfaction. Block chain is adapted to slower speeds, say 700 ft. per min. and under, and is extensively used on bicycles, small motor cars and machine tools. Where speed and pull are not fixed quantities, it is advisable to keep the speed high, and chain pull low, yet it should be borne in mind that high speeds are more destructive to chains of large than to those of small pitch.

The following table of tensile strengths, based on tests of "Diamond" chains taken from stock, may be considered a fair standard:

**ROLLER CHAIN.**

Pitch, in. . . . .	1/2	5/8	3/4	1	1 1/4	1 1/2	1 3/4	2
Tens. strength,								
lbs. . . . .	2,500	3,900	5,600	10,000	15,600	18,500	30,500	40,000
Block chain. . .	1 inch, 1,200 to 2,500;		1 1/2 inch, 5,000.					

The safe working load of a chain is dependent on the amount of rivet bearing surface, and varies from 1/6 to 1/30 of the tensile strength, according to the speed, size of sprockets, and other conditions peculiar to each case. The tendency now is to use the widest possible chain in order to secure maximum rivet bearing surface, thus insuring minimum wear from friction. Manufacturers are making heavier chains than heretofore for the same duty. As short pitch is always desirable, special double and even triple width chains are now made to conform to the requirements when a heavy single width chain of greater pitch is not practical. A double chain has a little more than twice the rivet bearing surface and half again as much tensile strength as the corresponding single one.

The length of chain for a given drive may be found by the following formula:

All dimensions in inches.  $D$  = Distance between centers of shafts.  $A$  = Distance between limiting points of contact.  $R$  = Pitch radius of large sprocket.  $r$  = Pitch radius of small sprocket.  $N$  = Number of teeth of large sprocket.  $n$  = Number of teeth of small sprocket.  $P$  = Pitch of chain and sprockets.  $(180^\circ + 2\alpha)$  = angle of contact on large sprocket.  $(180^\circ - 2\alpha)$  = angle of contact on small sprocket.  $\alpha$  = angle whose sine is  $(R - r)/D$ .  $A = D \cos \alpha$ .

Length of chain required:

$$L = \frac{180 + 2\alpha}{360} NP + \frac{180 - 2\alpha}{360} nP + 2D \cos \alpha.$$

For block chain, the total length specified in ordering should be in multiples of the pitch. For roller chain, the length should be in multiples of twice the pitch, as a union of the ends can be effected only with an outside and an inside link.

Wherever possible, the distance between centers of shafts should permit of adjustment in order to regulate the sag of the chain. A chain should be adjusted, in proportion to its length, to show slack when running, care being taken to have it neither too tight nor too loose, as either condition is destructive. If a fixed center distance must be used, and results in too much sag, the looseness should be taken up by an idler, and when there is any considerable tension on the slack side, this idler must be a sprocket. Where an idler is not practical, another combination of sprockets giving approximately the same speed ratio may be tried, and in this manner a combination giving the proper sag may always be obtained. The Diamond Chain and Mfg. Co. says that the center



line distance between sprockets should not be less than 11/2 times the diameter of the larger sprocket nor more than 10 or 12 ft.

In automobile drives, too much sag or too great a distance between shafts causes the chain to whip up and down—a condition detrimental to smooth running and very destructive to the chain. In this class of work a center distance of over 4 ft. has been used, but greater efficiency and longer life are secured from the chain on shorter lengths, say 3 ft. and under.

**Sprocket Wheels.** Properly proportioned and machined sprockets are essential to successful chain gearing. The important dimensions of a sprocket are the pitch diameter and the bottom and outside diameters. For block chain these are obtained as follows:

$N$  = No. of teeth.  $b$  = Diameter of round part of chain block.  $B$  = Center to center of holes in chain block.  $A$  = Center to center of holes in side links.  $\alpha = 180^\circ/N$ .  $\tan \beta = \sin \alpha \div (B/A + \cos \alpha)$ .

Pitch diameter =  $A/\sin \beta$ .

Bottom diam. = pitch diam. -  $b$ . Outside diam. = pitch diam. +  $b$ .

For roller chain:  $N$  = Number of teeth.  $P$  = Pitch of chain.  $D$  = Diameter of roller.  $\alpha = 180^\circ/N$ . Pitch diameter =  $P/\sin \alpha$ .

Bottom diam. = pitch diam. -  $D$ .

For sprockets of 17 teeth and over, outside diam. = pitch diam. +  $D$ . The outside diameters of small sprockets are cut down so that the teeth will clear the roller perfectly at high speeds.

Outside diam. = pitch diam. +  $D - E$ .

Pitch.	Values of $E$ .	
	8 to 12 Teeth.	13 to 16 Teeth.
1/2 in. to 3/4 in. ....	0.062 in.	0.031 in.
1 in. to 2 in. ....	0.125 in.	0.062 in.

Sprocket diameters should be very accurate, particularly the base diameter, which should not vary more than 0.002 in. from the calculated values. Sprockets should be gauged to discover thick teeth and inaccurate diameters. A poor chain may operate on a good sprocket, but a bad sprocket will ruin a good chain. Sprockets of 12 to 60 teeth give best results. Fewer may be used, but cause undue elongation in the chain, wear the sprockets and consume too much power. Eight-tooth sprockets ruin almost every roller chain applied to them, and ten and eleven teeth are fitted only for medium and slow speeds with other conditions unusually favorable.

Sprocket teeth seldom break from insufficient strength, but the tooth must be properly shaped. A chain will not run well unless the sprockets have sidewise clearance and teeth narrowed at the ends by curves beginning at the pitch line.

Calling  $W$  the width of the chain between the links,

$A = 1/2 W$  = width of tooth at top.  $B$  = uniform width below pitch line.

$B = W - 1/64$  in. when  $W = 1/4$  in. or less.

=  $W - 1/32$  in. when  $W = 5/16$  to  $5/8$  in. inclusive.

=  $W - 1/16$  in. when  $W = 3/4$  in. or over.

If the sprocket is flanged the chain must seat itself properly without the side bars coming into contact with the flange.

The principal cause of trouble within the chain is elongation. It is the result of stretch of material or natural wear of rivets and their bearings. To guard against the former, chain makers use special materials of high tensile strength, but a chain subjected to jars and jolts beyond the limit of elasticity of the material may be put in worse condition in an instant than in months of natural wear. If for any reason a link elongates unduly it should be replaced at once, as one elongated link will eventually ruin the entire chain. Such elongation frequently results from all the load being thrown on at once.

To minimize natural wear, chains should be well greased inside and out protected from mud and heavy grit, cleaned often and replaced to

run in the same direction and same side up. A new chain should never be applied to a much-worn sprocket.

**Importance of pitch line clearances:** In a sprocket with no clearances a new chain fits perfectly, but after natural wear the pitch of chain and sprocket become unlike. The chain is then elongated and climbs the teeth, which act as wedges, producing enormous strain, and it quickly wrecks itself. With the same chain on a driven sprocket, cut with clearances, all rollers seat against their teeth. After long and useful life, the working roller shifts to the top, and the other rollers still seat with the same ease as when new. Theoretically, all the rollers share the load. This never occurs in practice, for infinitesimal wear within the chain causes one, and only one, roller to bear perfectly seated against the working face of the sprocket tooth at any one time. Clearance alone on the driver will not provide for elongation. To operate properly the pitch of the driver must be lengthened, which is done by increasing the pitch diameter by an amount dependent upon the clearance allowed. For theoretical reasoning on this subject see "Roller Chain Gear," a treatise on English practice, by Hans Renold.

When the load reverses, each sprocket becomes alternately driver and driven. This happens in a motor car during positive and negative acceleration, or in ascending or descending a hill. In this event, the above construction is not applicable, for a driven sprocket of longer pitch than the chain will stretch it. No perfect method of equalizing the pitch of a roller chain and its sprockets under reversible load and at all periods of chain elongation has been found. This fault is eliminated in the "silent" type of chain; hence it runs smooth at a very much greater speed than roller chain will stand.

In practice there are comparatively few roller chain drives with chain pull always in the same direction, so manufacturers generally cut the driver sprockets for these with normal pitch diameter, same as the driven. Recent experiments have proven that the difficulties are greatly lessened by cutting both driver and driven with liberal pitch line clearance. Accordingly, chain makers now advise the following pitch line clearance for standard rollers:

Pitch, in.,	1/2	3/4	1	1 1/4	1 1/2	1 3/4	2
Clearance, in.,	1/32	1/16	3/32	3/16	7/32	1/8	5/32

Cutters may be obtained from Brown & Sharpe Mfg. Co. with this clearance.

**Belting versus Chain Drives.**—Chains are suitable for positive transmissions of very heavy powers at slow speed. They are properly used for conveying ashes, sand, chemicals and liquids which would corrode or destroy belting. Chains of this kind are generally made of malleable iron. For conveyers for clean substances, flour, wheat and other grains, belts are preferable, and in the best installations leather is preferred to cotton or rubber, being more durable. Transmission chains have to be carefully made. If the chain is to run smoothly, noiselessly, and without considerable friction, both the links and the sprockets must be mathematically correct. This perfection of design is found only in the highest and best makes of steel chain.

Deterioration of chains starts in with the beginning of service. Even in such light and flexible duty as bicycle transmission, a chain is subjected to sudden severe strains, which either stretch the chain or distort the bearing surfaces. Either mishap is fatal to smooth, frictionless running. If the transmission is positive, as from motor or shaft to a machine tool, sudden variations in strain become sledge-hammer blows, and the chain must either break or the parts yield. To avoid the evils arising from the stretching of the chain, self-adjusting forms of teeth have been invented, and the Renold and the Morse silent-chain gears are examples.

Chain drives are recommended for use under the following conditions: (1) Where room is lacking for the proper size pulleys for belts. (2) Where the centers between shafts are too short for belts. (3) Where a positive speed ratio is desired. (4) Where there is moisture, heat or dust that would prevent a belt working properly. (5) Where a maximum power per inch of width is desired.

The Renold and the Morse chain gears use springs in the sprocket

wheel to absorb the shock when a reversal of strain takes place, which is infrequent in ordinary power transmission, but is found in reciprocating air-compressors and pumps, in gas-engine drives where an insufficient balance wheel is supplied, and where a heavy shock load occurs and it is desirable to cushion the effect by mounting the wheel on springs.

Nickel steel is generally used for the chains. The joint pins are made from 3 1/2% nickel chrome steel, heat-treated. The ends of the joint pins are softened by an electric arc to facilitate riveting to the chain links.

#### Data Used in the Preliminary Design of Morse Silent Chain Drives

Pitch, in.....	1/2	5/8	3/4	9/10	1 2/10	1 1/2	2	3
Minimum no. of teeth:								
Small sprocket driver..	13	13	13	15	15	17	17	17
Small sprocket driven..	17	17	21	25	29	29	31	35
Desirable no. of teeth in small sprockets.....	15-17	17-21	17-21	17-23	17-23	17-27	17-31	19-31
Maximum no. of teeth in large sprockets. (See Note 3.).....	99	109	115	125	129	129	129	131
Desirable no. of teeth in large sprockets.....	55-75	55-75	55-85	55-95	55-105	55-115	55-115	55-115
Pitch diam. of wheel = no. of teeth × .....	0.159	0.199	0.239	0.2865	0.382	0.477	0.636	0.955
Addendum for outside diam. of sprockets 20 to 130 T. (See Note 1.), in.	0.10	0.12	0.15	0.18	0.24	0.30	0.40	0.60
Maximum r.p.m.....	2400	1800	1200	1100	850	600	400	250
Tension per in. width of chain, lb.:								
Small sprocket driver..	80	100	120	150	200	270	450	750
Small sprocket driven..	65	80	95	120	160	210	350	600
Radial clearance beyond tooth required for chain, in.....	0.50	0.62	0.75	0.90	1.2	1.5	2.0	3.0
Approx. weight of chain per in. wide, 1 ft. long, lb.....	1.00	1.20	1.50	1.80	2.50	3.00	4.00	6.00
C for solid pinions.....	0.0045	0.0063	0.009	0.013	0.023	0.035	0.058	0.145
C for armed sprockets ..	0.16	0.25	0.35	0.45	0.7	1.0	2.0	4.0

#### APPROXIMATE WEIGHTS FOR SOLID AND ARMED SPROCKETS.

$T$  = Number of teeth.  $F$  = Face in inches.  
 $C$  = Constant in lb. per in. in face per tooth as per table.  
 Weight of armed sprocket =  $T \times F \times C$ .  
 Add 25% for split and 50% for spring and split sprockets.  
 Weight of solid pinion =  $T^2 \times (F + 1) \times C$ .

#### NOTES.

- 1.—Number of teeth =  $T$ .  
Exact outside diameter =  $D$ .  
For  $T$  less than 20 teeth,  $D$  = pitch diameter.  
For  $T$  more than 20 teeth,  $D$  = pitch diameter + addendum.
- 2.—Use sprockets having an odd number of teeth whenever possible.
- 3.—When specially authorized, a larger number of teeth than shown may be cut in large sprocket.
- 4.—Thickness of sprocket rim, including teeth, should be at least 1.2 times the chain pitch.
- 5.—The number of grooves in the sprocket, their width and distance apart, varies according to pitch and width of chain. Leave the designing and turning of grooves to the manufacturer.
- 6.—The width of the sprocket should be 1/3 to 1/4 in. greater on small drives, and 1/4 to 1/2 in. greater on large drives than the nominal width of the chain.



- 7.—An even number of links in the chain and an odd number of teeth in the wheels are desirable.
- 8.—Horizontal drives preferred; tight chain on top necessary for short drives without center adjustment, and desirable for long drives with or without center adjustment.
- 9.—Adjustable wheel centers desirable for horizontal drives and necessary for vertical drives.
- 10.—Avoid vertical drives.
- 11.—Allow a side clearance for chain (parallel to axis of sprockets and measured from nominal width of chain) equal to the pitch.
- 12.—Maximum linear velocity for commercial service, 1200 to 1600 ft. per min.

**Comparison of Rope and Chain Drives.**—Horse-power, 1200; 240 to 80 r.p.m.

	Rope.	Chain.
Distance between centers.....	42 ft.	8 ft. 4 in.
Diameter driving sheave or sprocket.....	6 ft. 4 1/2 in.	30.21 in.
Diameter driven sheave or sprocket.....	20 ft.	89.42 in.

The rope drive has 30 ropes, each 1 3/4 in. diameter. The chain drive has a Morse silent chain, length, 33.5 ft.; width, 27 in.; pitch, 3 in.

#### Data of Some Chain Drives that Have Given Good Service

Pitch, In.	Width, In.	Speed, Ft. per Min.	Sprockets, No of Teeth.	Center Distance, In.	Rev. per Min.	H.P. Trans- mitted.
5/8	2 1/2	1550	17 & 75	25.5	1750 & 397	7.5
1 1/2	12	1150	95 & 95	85	97 & 97	200
1 1/2	18	715	59 & 95	169	97 & 60	200
2	5	1400	29 & 57	68	418 & 290	85
3	12	1450	61 & 77	135	95 & 75	500
3	24	1450	61 & 83	103	95 & 70	1000
3	27	1870	30 & 89	100	240 & 80	1200
2	24	780	26 & 120	144	300 & 65	350

A chain transmission gear of 5000 H.P. has been built, with the total width of chain 168 in. The efficiency of the best chain drives when in good condition is claimed to be from 98 to 99%.

## GEARING.

### TOOTHED-WHEEL GEARING.

**Pitch, Pitch-circle, etc.**—If two cylinders with parallel axes are pressed together and one of them is rotated on its axis, it will drive the other by means of the friction between the surfaces. The cylinders may be considered as a pair of spur-wheels with an infinite number of very small teeth. If actual teeth are formed upon the cylinders, making alternate elevations and depressions in the cylindrical surfaces, the distance between the axes remaining the same, we have a pair of gear-wheels which will drive one another by pressure upon the faces of the teeth, if the teeth are properly shaped. In making the teeth the cylindrical surface may entirely disappear, but the position it occupied may still be considered as a cylindrical surface, which is called the "pitch-surface," and its trace on the end of the wheel, or on a plane cutting the wheel at right angles to its axis, is called the "pitch-circle" or "pitch-line." The diameter of this circle is called the pitch-diameter, and the distance from the face of one tooth to the corresponding face of the next tooth on the same wheel, measured on an arc of the pitch-circle, is called the "pitch of the tooth," or the circular pitch.

If two wheels having teeth of the same pitch are geared together so that their pitch-circles touch, it is a property of the pitch-circles that their diameters are proportional to the number of teeth in the wheels, and vice versa; thus, if one wheel is twice the diameter (measured on the pitch-circle) of the other, it has twice as many teeth. If the teeth are properly shaped the linear velocities of the two wheels are equal, and the angular velocities, or speeds of rotation, are inversely proportional to the

number of teeth and to the diameter. Thus the wheel that has twice as many teeth as the other will revolve just half as many times in a minute.

The "pitch," or distance measured on an arc of the pitch-circle from the face of one tooth to the face of the next, consists of two parts—the "thickness" of the tooth and the "space" between it and the next tooth. The space is larger than the thickness by a small amount called the "backlash," which is allowed for imperfections of workmanship. In finely cut gears the backlash may be almost nothing.

The length of a tooth in the direction of the radius of the wheel is called the "depth," and this is divided into two parts: First, the "addendum," the height of the tooth above the pitch line; second, the "dedendum," the depth below the pitch-line, which is an amount equal to the addendum of the mating gear. The depth of the space is usually given a little "clearance" to allow for inaccuracies of workmanship, especially in cast gears.

Referring to Fig. 178, *pl, pl* are the pitch-lines, *al* the addendum-line, *rl* the root-line or dedendum-line, *cl* the clearance-line, and *b* the backlash. The addendum and dedendum are usually made equal to each other. (Some writers make the dedendum include the clearance.)

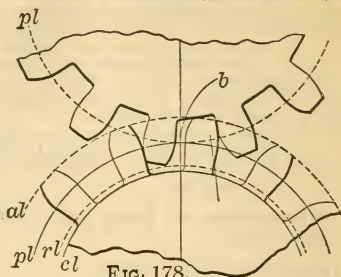

FIG. 178.

$$\text{Diametral pitch} = \frac{\text{No. of teeth}}{\text{diam. of pitch-circle in inches}} = \frac{3.1416}{\text{circular pitch}};$$

$$\text{Circular pitch} = \frac{\text{diam.} \times 3.1416}{\text{No. of teeth}} = \frac{3.1416}{\text{diametral pitch}}.$$

Some writers use the term diametral pitch to mean  $\frac{\text{diam.}}{\text{No. of teeth}} = \frac{3.1416}{\text{circular pitch}}$ , but the first definition is the more common and the more convenient.

A wheel of 12 in. diam. at the pitch-circle, with 48 teeth, is  $48/12 = 4$  diametral pitch, or simply 4 pitch. The circular pitch of the same wheel is  $12 \times 3.1416 \div 48 = 0.7854$ , or  $3.1416 \div 4 = 0.7854$  in.

#### Relation of Diametral to Circular Pitch.

Diametral Pitch.	Circular Pitch.	Diametral Pitch.	Circular Pitch.	Circular Pitch.	Diametral Pitch.	Circular Pitch.	Diametral Pitch.
1	3.142 in.	11	0.286 in.	3	1.047	15/16	3.351
1 1/2	2.094	12	.262	2 1/2	1.257	7/8	3.590
2	1.571	14	.224	2	1.571	13/16	3.867
2 1/4	1.396	16	.196	1 7/8	1.676	3/4	4.189
2 1/2	1.257	18	.175	1 3/4	1.795	11/16	4.570
2 3/4	1.142	20	.157	1 5/8	1.933	5/8	5.027
3	1.047	22	.143	1 1/2	2.094	9/16	5.585
3 1/2	0.898	24	.131	1 7/16	2.185	1/2	6.283
4	.785	26	.121	1 3/8	2.285	7/16	7.181
5	.628	28	.112	1 5/16	2.394	3/8	8.378
6	.524	30	.105	1 1/4	2.513	5/16	10.053
7	.449	32	.098	1 3/16	2.646	1/4	12.566
8	.393	36	.087	1 1/8	2.793	3/16	16.755
9	.349	40	.079	1 1/16	2.957	1/8	25.133
10	.314	48	.065	1	3.142	1/16	50.266

$$\text{Since circ. pitch} = \frac{\text{diam.} \times 3.1416}{\text{No. of teeth}}, \text{ diam.} = \frac{\text{circ. pitch} \times \text{No. of teeth}}{3.1416},$$

which always brings out the diameter as a number with an inconvenient fraction if the pitch is in even inches or simple fractions of an inch. By

the diametral-pitch system this inconvenience is avoided. The diameter may be in even inches or convenient fractions, and the number of teeth is usually an even multiple of the number of inches in the diameter.

**Diameter of Pitch-line of Wheels from 10 to 100 Teeth of 1 in. Circular Pitch.**

No. Teeth.	Diam., in.	No. Teeth.	Diam., in.	No. Teeth.	Diam., in.	No. Teeth.	Diam., in.	No. Teeth.	Diam., in.	No. Teeth.	Diam., in.
10	3.183	26	8.276	41	13.051	56	17.825	71	22.600	86	27.375
11	3.501	27	8.594	42	13.369	57	18.144	72	22.918	87	27.693
12	3.820	28	8.913	43	13.687	58	18.462	73	23.236	88	28.011
13	4.138	29	9.231	44	14.006	59	18.781	74	23.555	89	28.329
14	4.456	30	9.549	45	14.324	60	19.099	75	23.873	90	28.648
15	4.775	31	9.868	46	14.642	61	19.417	76	24.192	91	28.966
16	5.093	32	10.186	47	14.961	62	19.735	77	24.510	92	29.285
17	5.411	33	10.504	48	15.279	63	20.054	78	24.828	93	29.603
18	5.730	34	10.823	49	15.597	64	20.372	79	25.146	94	29.921
19	6.048	35	11.141	50	15.915	65	20.690	80	25.465	95	30.239
20	6.366	36	11.459	51	16.234	66	21.008	81	25.783	96	30.558
21	6.685	37	11.777	52	16.552	67	21.327	82	26.101	97	30.876
22	7.003	38	12.096	53	16.870	68	21.645	83	26.419	98	31.194
23	7.321	39	12.414	54	17.189	69	21.963	84	26.738	99	31.512
24	7.639	40	12.732	55	17.507	70	22.282	85	27.056	100	31.831
25	7.958	....	.....	.....	.....	.....	.....	.....	.....	.....	.....

For diameter of wheels of any other pitch than 1 in., multiply the figures in the table by the pitch. Given the diameter and the pitch, to find the number of teeth. Divide the diameter by the pitch, look in the table under diameter for the figure nearest to the quotient, and the number of teeth will be found opposite.

**Proportions of Teeth. Circular Pitch = 1.**

	1.	2.	3.	4.	5.	6.
Depth of tooth above pitch-line.....	0.35	0.30	0.37	0.33	0.30	0.30
Depth of tooth below pitch-line.....	.40	.40	.43	.....	.40	.35
Working depth of tooth.....	.70	.60	.73	.66	.....	.....
Total depth of tooth.....	.75	.70	.80	.75	.70	.65
Clearance at root.....	.05	.10	.07	.....	.....	.....
Thickness of tooth.....	.45	.45	.47	.45	.475	.485
Width of space.....	.54	.55	.53	.55	.525	.515
Backlash.....	.09	.10	.06	.10	.05	.03
Thickness of rim.....	.....	.....	.47	.45	.70	.65

	7.	8.	9.	10.*
Depth of tooth above pitch-line.....	0.25 to 0.33	0.30	0.318	1 ÷ P
Depth of tooth below pitch-line.....	.35 to .42	.35 + .08"	.369	1.157 ÷ P
Working depth of tooth...	.....	.....	.637	2 ÷ P
Total depth of tooth.....	.6 to .75	.65 + .08"	.687	2.157 ÷ P
Clearance at root.....	.....	.....	.04 to .05	0.157 ÷ P
Thickness of tooth.....	.48 to .485	.48 - .03"	.48 to .5	1.51 ÷ P to 1.57 ÷ P
Width of space.....	.52 to .515	.52 + .03"	.52 to .5	1.57 ÷ P to 1.63 ÷ P
Backlash.....	.04 to .03	.04 + .06"	.0 to .04	.0 to .06 ÷ P

\* In terms of diametral pitch.

**AUTHORITIES.** — 1. Sir Wm. Fairbairn. 2, 3. Clark, R. T. D.; "used by engineers in good practice." 4. Molesworth. 5, 6. Coleman Sellers: 5 for cast, 6 for cut wheels. 7, 8. Unwin. 9, 10. Leading American manufacturers of cut gears.

**The Chordal Pitch** (erroneously called "true pitch" by some authors) is the length of a straight line or chord drawn from center to center of two adjacent teeth. The term is now but little used, except in connection with chain and sprocket gearing.



Chordal pitch = diam. of pitch-circle  $\times$  sine of  $\frac{180^\circ}{\text{No. of teeth}}$ . Chordal pitch of a wheel of 10 in. pitch diameter and 10 teeth,  $10 \times \sin 18^\circ = 3.0902$  in. Circular pitch of same wheel = 3.1416. Chordal pitch is used with chain or sprocket wheels, to conform to the pitch of the chain.

**Gears with Short Teeth.** — There is a tendency in recent years to depart widely from the proportions of teeth given in the above and to use much shorter teeth, especially for heavy machinery. C. W. Hunt gives addendum and dedendum each = 0.25, and the clearance 0.05 of the circular pitch, making the total depth of tooth 0.55 of the circular pitch. The face of the tooth is involute in form, and the angle of action is  $14\frac{1}{2}^\circ$ , C. H. Logue uses a  $20^\circ$  involute with the following proportions: Addendum  $0.25P' = 0.7854 \div P$ ; dedendum  $0.30P' = 0.9424 \div P$ ; clearance,  $0.05P' = 0.157P$ ; whole depth  $0.55P' = 1.7278 \div P$ .  $P'$  = circular pitch,  $P$  = diametral pitch. See papers by R. E. Flanders and Norman Litchfield in *Trans. A. S. M. E.*, 1908.

John Walker (*Am. Mach.*, Mar. 11, 1897) says: For special purposes of slow-running gearing with great tooth stress I should prefer a length of tooth of 0.4 of the pitch, but for general work a length of 0.6 of the pitch. In 1895 Mr. Walker made two pairs of cut steel gears for the Chicago cable railway with 6-in. circular pitch, length = 0.4 pitch. The pinions had 42 teeth and the gears 62, each 20-in. face. The two pairs were set side by side on their shafts, so as to stagger the teeth, making the total face 40 ins. The gears transmitted 1500 H.P. at 60 r.p.m. replacing cast-iron gears of  $7\frac{1}{2}$  in. pitch which had broken in service.

**Formulae for Determining the Dimensions of Small Gears.**

(Brown & Sharpe Mfg. Co.)

$P$  = diametral pitch or the number of teeth to one inch of diameter of pitch-circle;

$D'$ = diameter of pitch-circle.....	Larger Wheel.	These wheels run together.
$D$ = whole diameter.....		
$N$ = number of teeth.....		
$V$ = velocity.....		
$d'$ = diameter of pitch-circle.....	Smaller Wheel.	
$d$ = whole diameter.....		
$n$ = number of teeth.....		
$v$ = velocity.....		

$a$  = distance between the centers of the two wheels;

$b$  = number of teeth in both wheels;

$t$  = thickness of tooth or cutter on pitch-circle;

$s$  = addendum;

$D''$  = working depth of tooth;

$f$  = amount added to depth of tooth for rounding the corners and for clearance;

$D'' + f$  = whole depth of tooth;

$\pi = 3.1416$ .

$P'$  = circular pitch, or the distance from the center of one tooth to the center of the next measured on the pitch-circle.

Formulae for a single wheel:

$$P = \frac{N + 2}{D}; \quad D' = \frac{D \times N}{N + 2}; \quad D'' = \frac{2}{P} = 2s; \quad s = \frac{1}{P} = \frac{P'}{\pi} = 0.3183 P';$$

$$P = \frac{N}{D'}; \quad D' = \frac{N}{P}; \quad N = PD - 2; \quad s = \frac{D'}{N} = \frac{D}{N + 2};$$

$$P' = \frac{\pi}{P}; \quad D = \frac{N + 2}{P}; \quad f = \frac{t}{10}; \quad s + f = \frac{1}{P} \left( 1 + \frac{\pi}{20} \right) = 0.3685 P.$$

$$P = \frac{\pi}{P'}; \quad D = D' + \frac{2}{P}; \quad t = \frac{1.57}{P} = 1/2 P'.$$

Formulae for a pair of wheels:

$$b = 2 aP; \quad n = \frac{PD'V}{v}; \quad D = \frac{2a(N + 2)}{b};$$

$$N = \frac{nv}{V}; \quad v = \frac{PD'V}{n}; \quad \bar{a} = \frac{2a(n + 2)}{b};$$

$$\begin{aligned}
 n &= \frac{NV}{v}; & v &= \frac{NV}{n}; & a &= \frac{b}{2P}; \\
 N &= \frac{bv}{v+V}; & V &= \frac{nv}{N}; & a &= \frac{D'+d'}{2}; \\
 n &= \frac{bV}{v+V}; & D' &= \frac{2av}{v+V}; & d' &= \frac{2aV}{v+V}.
 \end{aligned}$$

**Width of Teeth.** — The width of the faces of teeth is generally made from 2 to 3 times the circular pitch, that is from 6.28 to 9.42 divided by the diametral pitch. There is no standard rule for width.

The following sizes are given in a stock list of cut gears in "Grant's Gears:"

Diametral pitch...	3	4	6	8	12	16
Face, inches.....	3 and 4	2 1/2	1 3/4 and 2	1 1/4 and 1 1/2	3/4 and 1	1/2 and 5/8

The Walker Company gives:

Circular pitch, in..	1/2	5/8	3/4	7/8	1	1 1/2	2	2 1/2	3	4	5	6
Face, in.....	1 1/4	1 1/2	1 3/4	2	2 1/2	4 1/2	6	7 1/2	9	12	16	20

The following proportions of gear-wheels are recommended by Prof. Coleman Sellers. (*Stevens Indicator*, April, 1892.)

**Proportions of Gear-wheels.**

Diametral Pitch.	Circular Pitch. <i>P</i>	Outside of Pitch-line. <i>P</i> × 0.3.	Inside of Pitch-line.		Width of Space.	
			For Cast or Cut Bevels or for Cast Spurs. <i>P</i> × 0.4.	For Cut Spurs. <i>P</i> × 0.35.	For Cast Spurs or Bevels. <i>P</i> × 0.525.	For Cut Bevels or Spurs. <i>P</i> × 0.51.
	1/4	0.075	0.100	0.088	0.131	0.128
12	0.2618	.079	.105	.092	.137	.134
10	0.31416	.094	.126	.11	.165	.16
	3/8	.113	.150	.131	.197	.191
8	0.3927	.118	.157	.137	.206	.2
7	0.4477	.134	.179	.157	.235	.228
	1/2	.15	.20	.175	.263	.255
6	0.5236	.157	.209	.183	.275	.267
	9/16	.169	.225	.197	.295	.287
	5/8	.188	.25	.219	.328	.319
5	0.62832	.188	.251	.22	.33	.32
	3/4	.225	.3	.263	.394	.383
4	0.7854	.236	.314	.275	.412	.401
	7/8	.263	.35	.307	.459	.446
	1	.3	.4	.35	.525	.51
3	1.0472	.314	.419	.364	.55	.534
	1 1/8	.338	.45	.394	.591	.574
2 3/4	1.1424	.343	.457	.40	.6	.583
	1 1/4	.375	.5	.438	.656	.638
2 1/2	1.25664	.377	.503	.44	.66	.641
	1 3/8	.413	.55	.481	.722	.701
	1 1/2	.45	.6	.525	.788	.765
2	1.5708	.471	.628	.55	.825	.801
	1 3/4	.525	.7	.613	.919	.893
	2	.6	.8	.7	1.05	1.02
1 1/2	2.0944	.628	.838	.733	1.1	1.068
	2 1/4	.675	.9	.788	1.181	1.148
	2 1/2	.75	1.0	.875	1.313	1.275
	2 3/4	.825	1.1	.963	1.444	1.403
	3	.9	1.2	1.05	1.575	1.53
	3.1416	.942	1.257	1.1	1.649	1.602
	3 1/4	.975	1.3	1.138	1.706	1.657
	3 1/2	1.05	1.4	1.225	1.838	1.785

Thickness of rim below root = depth of tooth.

**Rules for Calculating the Speed of Gears and Pulleys.** — The relations of the size and speed of driving and driven gear-wheels are the same as those of belt pulleys. In calculating for gears, multiply or divide by the diameter of the pitch-circle or by the number of teeth, as may be required. In calculating for pulleys, multiply or divide by their diameter in inches.

If  $D$  = diam. of driving wheel,  $d$  = diam. of driven,  $R$  = revolutions per minute of driver,  $r$  = revs. per min. of driven,  $RD = rd$ ;

$$R = rd \div D; r = RD \div d; D = dr \div R; d = DR \div r.$$

If  $N$  = No. of teeth of driver and  $n$  = No. of teeth of driven,  $NR = nr$ ;

$$N = nr \div R; n = NR \div r; R = rn \div N; r = RN \div n.$$

To find the number of revolutions of the last wheel at the end of a train of spur-wheels, all of which are in a line and mesh into one another, when the revolutions of the first wheel and the number of teeth or the diameter of the first and last are given: Multiply the revolutions of the first wheel by its number of teeth or its diameter, and divide the product by the number of teeth or the diameter of the last wheel.

To find the number of teeth in each wheel for a train of spur-wheels, each to have a given velocity: Multiply the number of revolutions of the driving-wheel by its number of teeth, and divide the product by the number of revolutions each wheel is to make.

To find the number of revolutions of the last wheel in a train of wheels and pinions, when the revolutions of the first or driver, and the diameter, the teeth, or the circumference of all the drivers and pinions are given: Multiply the diameter, the circumference, or the number of teeth of all the driving-wheels together, and this continued product by the number of revolutions of the first wheel, and divide this product by the continued product of the diameter, the circumference, or the number of teeth of all the driven wheels, and the quotient will be the number of revolutions of the last wheel.

**EXAMPLE.** — 1. A train of wheels consists of four wheels each 12 in. diameter of pitch-circle, and three pinions 4, 4, and 3 in. diameter. The large wheels are the drivers, and the first makes 36 revs. per min. Required the speed of the last wheel.

$$\frac{36 \times 12 \times 12 \times 12}{4 \times 4 \times 3} = 1296 \text{ r.p.m.}$$

2. What is the speed of the first large wheel if the pinions are the drivers, the 3-in. pinion being the first driver and making 36 revs. per min.?

$$\frac{36 \times 3 \times 4 \times 4}{12 \times 12 \times 12} = 1 \text{ r.p.m. } \textit{Ans.}$$

**Milling Cutters for Interchangeable Gears.**—The Pratt & Whitney Co. makes a series of cutters for cutting epicycloidal teeth. The number of cutters to cut from a pinion of 12 teeth to a rack is 24 for each pitch coarser than 10. The Brown & Sharpe Mfg. Co. makes a similar series, and also a series for involute teeth, in which eight cutters are made for each pitch, as follows:

No. ....	1	2	3	4	5	6	7	8
Will cut from	135	55	35	26	21	17	14	12
to Rack	134	54	34	25	20	16	13	

**FORMS OF THE TEETH.**

In order that the teeth of wheels and pinions may run together smoothly and with a constant relative velocity, it is necessary that their working faces shall be formed of certain curves called odontoids. The essential property of these curves is that when two teeth are in contact the common normal to the tooth curves at their point of contact must pass through the pitch-point, or point of contact of the two pitch-circles. Two such curves are in common use — the cycloid and the involute.

**The Cycloidal Tooth.** — In Fig. 179 let  $PL$  and  $pl$  be the pitch-circles of two gear-wheels;  $GC$  and  $gc$  are two equal generating-circles, whose radii should be taken as not greater than one-half of the radius of the smaller pitch-circle. If the circle  $gc$  be rolled to the left on the larger pitch-circle  $PL$ , the point  $O$  will describe an epicycloid,  $Oefgh$ . If the other generating-circle  $GC$  be rolled to the right on  $Pl$ , the point  $O$  will describe a hypocycloid  $Oabcd$ . These two curves, which are tangent



at  $O$ , form the two parts of a tooth curve for a gear whose pitch-circle is  $PL$ . The upper part  $Oh$  is called the face and the lower part  $Od$  is called the flank. If the same circles be rolled on the other pitch-circle  $pl$ , they will describe the curve for a tooth of the gear  $pl$ , which will work properly with the tooth on  $PL$ .

The cycloidal curves may be drawn without actually rolling the generating-circle, as follows: On the line  $PL$ , from  $O$ , step off and mark equal distances, as 1, 2, 3, 4, etc. From 1, 2, 3, etc., draw radial lines toward the center of  $PL$ , and from 6, 7, 8, etc., draw radial lines from the same center, but beyond  $PL$ . With the radius of the generating-circle, and with centers successively placed on these radial lines, draw arcs of circles tangent to  $PL$  at 1, 2, 3, 6, 7, 8, etc. With the dividers set to one of the equal divisions, as  $O1$ , step off on the generating circle  $gc$  the points  $a'$ ,  $b'$ ,  $c'$ ,  $d'$ , then take successively the chordal distances  $0a$ ,  $0b'$ ,  $0c'$ ,  $0d'$ , and lay them off on the several arcs  $6e$ ,  $7f$ ,  $8g$ ,  $9h$ , and  $1a$ ,  $2b$ ,  $3c$ ,  $4d$ ; through the points  $efgh$  and  $abcd$  draw the tooth curves.

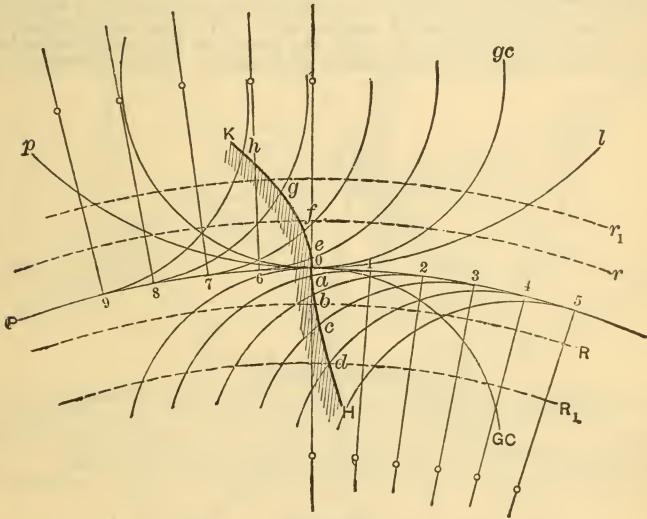

FIG. 179.

The curves for the mating tooth on the other wheel may be found in like manner by drawing arcs of the generating-circle tangent at equidistant points on the pitch-circle  $pl$ .

The tooth curve of the face  $Oh$  is limited by the addendum-line  $r$  or  $r_1$ , and that of the flank  $OH$  by the root curve  $R$  or  $R_1$ .  $R$  and  $r$  represent the root and addendum curves for a large number of small teeth, and  $R_1$  and  $r_1$  the like curves for a small number of large teeth. The form or appearance of the tooth therefore varies according to the number of teeth, while the pitch-circle and the generating-circle may remain the same.

In the cycloidal system, in order that a set of wheels of different diameters but equal pitches shall all correctly work together, it is necessary that the generating-circle used for the teeth of all the wheels shall be the same, and it should have a diameter not greater than half the diameter of the pitch-line of the smallest wheel of the set. The customary standard size of the generating-circle of the cycloidal system is one having a diameter equal to the radius of the pitch-circle of a wheel having 12 teeth. (Some gear-makers adopt 15 teeth.) This circle gives a radial flank to the teeth of a wheel having 12 teeth. A pinion of 10 or even a smaller number of teeth can be made, but in that case the flanks will be

undercut, and the tooth will not be as strong as a tooth with radial flanks. If in any case the describing circle be half the size of the pitch-circle, the flanks will be radial; if it be less, they will spread out toward the root of the tooth, giving a stronger form; but if greater, the flanks will curve in toward each other, whereby the teeth become weaker and difficult to make.

In some cases cycloidal teeth for a pair of gears are made with the generating-circle of each gear having a radius equal to half the radius of its pitch-circle. In this case each of the gears will have radial flanks. This method makes a smooth working gear, but a disadvantage is that the wheels are not interchangeable with other wheels of the same pitch but different numbers of teeth.

The rack in the cycloidal system is equivalent to a wheel with an infinite number of teeth. The pitch is equal to the circular pitch of the mating gear. Both faces and flanks are cycloids formed by rolling the generating-circle of the mating gear-wheel on each side of the straight pitch-line of the rack.

Another method of drawing the cycloidal curves is shown in Fig. 180. It is known as the method of tangent arcs. The generating-circles, as before, are drawn with equal radii, the length of the radius being less than half the radius of  $pl$ , the smaller pitch-circle. Equal divisions 1, 2,

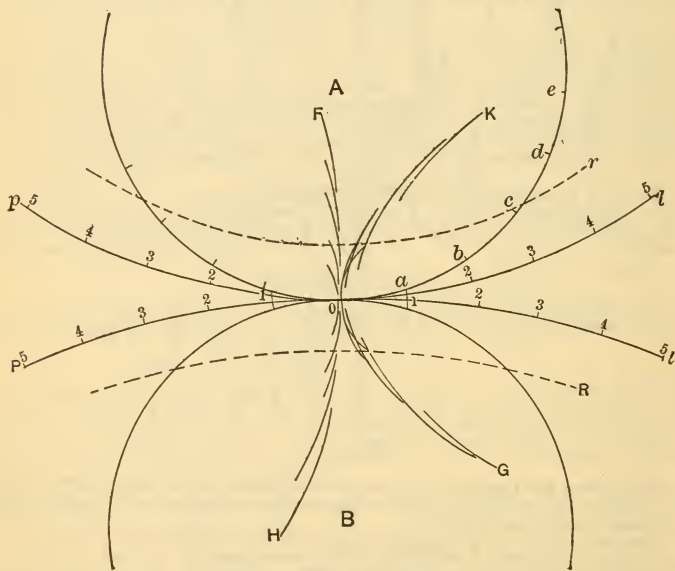

FIG. 180.

3, 4, etc., are marked off on the pitch-circles and divisions of the same length stepped off on one of the generating-circles, as 0,  $a$ ,  $b$ ,  $c$ . From the points 1, 2, 3, 4, 5 on the line  $p0$ , with radii successively equal to the chord distances  $0a$ ,  $0b$ ,  $0c$ ,  $0d$ ,  $0e$ , draw the five small arcs  $F$ . A line drawn through the outer edges of these small arcs, tangent to them all, will be the hypocycloidal curve for the flank of a tooth below the pitch-line  $pl$ . From the points 1, 2, 3, etc., on the line  $0l$ , with radii as before, draw the small arcs  $G$ . A line tangent to these arcs will be the epicycloid for the face of the same tooth for which the flank curve has already been drawn. In the same way, from centers on the line  $P0$ , and  $0L$ , with the same radii, the tangent arcs  $H$  and  $K$  may be drawn, which will give the tooth for the gear whose pitch-circle is  $PL$ .

If the generating-circle had a radius just one-half of the radius of  $pl$ , the hypocycloid  $F$  would be a straight line, and the flank of the tooth would have been radial.

**The Involute Tooth.** — In drawing the involute-tooth curve, Fig. 181, the angle of obliquity, or the angle which a common tangent to the teeth, when they are in contact at the pitch-point, makes with a line joining the centers of the wheels, is first arbitrarily determined. It is customary to take it at  $15^\circ$ . The pitch-lines  $pl$  and  $PL$  being drawn in contact at  $O$ , the line of obliquity  $AB$  is drawn through  $O$  normal to a common tangent to the tooth curves, or at the given angle of obliquity to a common tangent to the pitch-circles. In the cut the angle is  $20^\circ$ . From the centers of the pitch-circles draw circles  $c$  and  $d$  tangent to the line  $AB$ . These circles are called base-lines or base-circles, from which the involutes  $F$  and  $K$  are drawn. By laying off convenient distances, 0, 1, 2, 3, which should each be less than  $\frac{1}{10}$  of the diameter of the base-circle, small arcs can be drawn with successively increasing radii, which will form the involute. The involute extends from the points  $F$  and  $K$  down to their

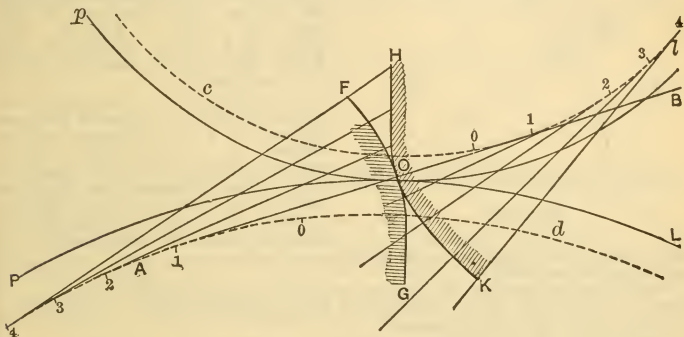

FIG. 181.

respective base-circles, where a tangent to the involute becomes a radius of the circle, and the remainders of the tooth curves, as  $G$  and  $H$ , are radial straight lines.

**To draw the teeth of a rack which is to gear with an involute wheel (Fig. 182).** — Let  $AB$  be the pitch-line of the rack and  $AI = II' =$  the pitch. Through the pitch-point  $I$  draw  $EF$  at the given angle of obliquity.

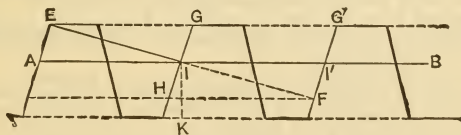

FIG. 182.

Draw  $AE$  and  $I'F$  perpendicular to  $EF$ . Through  $E$  and  $F$  draw lines  $EGG'$  and  $HF$  parallel to the pitch-line.  $EGG'$  will be the addendum-line and  $HF$  the flank-line. From  $I$  draw  $IK$  perpendicular to  $AB$  equal to the greatest addendum in the set of wheels of the given pitch and obliquity plus an allowance for clearance equal to  $\frac{1}{8}$  of the addendum. Through  $K$ , parallel to  $AB$ , draw the clearance-line. The fronts of the teeth are planes perpendicular to  $EF$ , and the backs are planes inclined at the same angle to  $AB$  in the contrary direction. The outer half of the working face  $AE$  may be slightly curved. Mr. Grant makes it a circular arc drawn from a center on the pitch-line with a radius = 2.1 inches divided by the diametral pitch, or 0.67 in.  $\times$  circular pitch.

In the involute system the customary standard form of tooth is one having an angle of obliquity of  $15^\circ$  (Brown and Sharpe use  $14\frac{1}{2}^\circ$ ), an



addendum of about one-third the circular pitch, and a clearance of about one-eighth of the addendum. In this system the smallest gear of a set has 12 teeth, this being the smallest number of teeth that will gear together when made with this angle of obliquity. In gears with less than 30 teeth the points of the teeth must be slightly rounded over to avoid interference (see Grant's Teeth of Gears). All involute teeth of the same pitch and with the same angle of obliquity work smoothly together. The rack to gear with an involute-toothed wheel has straight faces on its teeth, which make an angle with the middle line of the tooth equal to the angle of obliquity, or in the standard form the faces are inclined at an angle of  $30^\circ$  with each other.

*To Draw an Angle of  $15^\circ$  without using a Protractor.* — From *C*, on the line *AC*, with radius *AC*, draw an arc *AB*, and from *A*, with the same

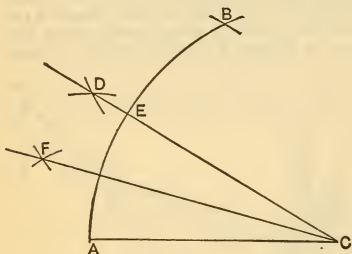

FIG. 183.

radius, cut the arc at *B*. Bisect the arc *BA* by drawing small arcs at *D* from *A* and *B* as centers, with the same radius, which must be greater than one-half of *AB*. Join *DC*, cutting *BA* at *E*. The angle *ECA* is  $30^\circ$ . Bisect the arc *ECA* in like manner, and the angle *FCA* will be  $15^\circ$ .

A property of involute-toothed wheels is that the distance between the axes of a pair of gears may be altered to a considerable extent without interfering with their action. The backlash is therefore variable at will, and may be adjusted by moving the wheels farther from or nearer to each other, and

may thus be adjusted so as to be no greater than is necessary to prevent jamming of the teeth.

The relative merits of cycloidal and involute-shaped teeth are a subject of dispute, but there is an increasing tendency to adopt the involute tooth for all purposes.

Clark (R. T. D., p. 734) says: Involute teeth have the disadvantage of being too much inclined to the radial line, by which an undue pressure is exerted on the bearings.

Unwin (Elements of Machine Design, 8th ed., p. 265) says: The obliquity of action is ordinarily alleged as a serious objection to involute wheels. Its importance has perhaps been overrated.

George B. Grant (*Am. Mach.*, Dec. 26, 1885) says:

1. The work done by the friction of an involute tooth is always less than the same work for any possible epicycloidal tooth.

2. With respect to work done by friction, a change of the base from a gear of 12 teeth to one of 15 teeth makes an improvement for the epicycloid of less than one-half of one per cent.

3. For the 12-tooth system the involute has an advantage of  $1\frac{1}{5}$  per cent, and for the 15-tooth system an advantage of  $\frac{3}{4}$  per cent.

4. That a maximum improvement of about one per cent can be accomplished by the adoption of any possible non-interchangeable radial flank tooth in preference to the 12-tooth interchangeable system.

5. That for gears of very few teeth the involute has a decided advantage.

6. That the common opinion among millwrights and the mechanical public in general in favor of the epicycloid is a prejudice that is founded on long-continued custom, and not on an intimate knowledge of the properties of that curve.

Wilfred Lewis (*Proc. Engrs. Club of Phila.*, vol. x, 1893) says a strong reaction in favor of the involute system is in progress, and he believes that an involute tooth of  $22\frac{1}{2}^\circ$  obliquity will finally supplant all other forms.

**Approximation by Circular Arcs.** — Having found the form of the actual tooth-curve on the drawing-board, circular arcs may be found by trial which will give approximations to the true curves, and these may be used in completing the drawing and the pattern of the gear-wheels. The

root of the curve is connected to the clearance by a fillet, which should be as large as possible to give increased strength to the tooth, provided it is not large enough to cause interference.

Molesworth gives a method of construction by circular arcs as follows:

From the radial line at the edge of the tooth on the pitch-line, lay off the line *HK* at an angle of  $75^\circ$  with the radial line; on this line will be the centers of the root *AB* and the point *EF*. The lines struck from these centers are shown in thick lines. Circles drawn through centers thus found will give the lines in which the remaining centers will be. The radius *DA* for striking the root *AB* is the pitch + the thickness of the tooth. The radius *CE* for striking the point of the tooth *EF* = the pitch.

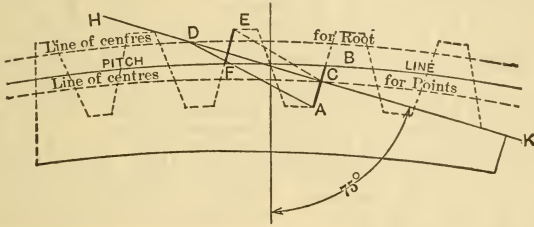

FIG. 184.

George B. Grant says: It is sometimes attempted to construct the curve by some handy method or empirical rule, but such methods are generally worthless.

**Stub Gear Teeth.**—The stub gear tooth developed by the Fellows Gear Shaper Co. has been largely adopted for automobile drives. The stub gear tooth has a shorter addendum and dedendum than the ordinary involute tooth. The pressure angle is  $20^\circ$  and the teeth are based on two diametral pitches, one of which is used to obtain the dimensions of the addendum and dedendum, while the other is used for the dimensions of the tooth thickness, the number of teeth and pitch diameter. Stub tooth gears are designated by a fraction as  $\frac{4}{5}$  pitch,  $\frac{10}{12}$  pitch, etc. The numerator designates the pitch determining the thickness of the tooth and number of teeth. The denominator designates the pitch determining depth of the tooth. The clearance is  $(0.25 \div \text{diametral pitch})$ . The advantages of this form of tooth compared to the ordinary involute gear tooth are: greater strength; same arc of rolling contact as in  $14\frac{1}{2}^\circ$  involute tooth; avoidance of extreme sliding contact; more even wearing contact. Dimensions of the Fellows system of stub gear teeth are given in the table below:

**Fellows Stub Gear Tooth System (Dimensions in Inches).**

Diametral Pitch.	Thick-ness of Tooth.	Adden-dum.	Working Depth.	Depth of Space Below Pitch Line.	Clear-an e.	Whole Depth of Tooth.
$\frac{4}{5}$	0.3927	0.2000	0.4000	0.2500	0.0500	0.4500
$\frac{5}{7}$	.3142	.1429	.2858	.1786	.0357	.3214
$\frac{6}{8}$	.2618	.1250	.2500	.1562	.0312	.2812
$\frac{7}{9}$	.2244	.1111	.2222	.1389	.0278	.2500
$\frac{8}{10}$	.1963	.1000	.2000	.1250	.0250	.2250
$\frac{9}{11}$	.1745	.0909	.1818	.1136	.0227	.2045
$\frac{10}{12}$	.1571	.0833	.1667	.1041	.0208	.1875
$\frac{12}{14}$	.1309	.0714	.1429	.0993	.0179	.1607

Another system of stub gear teeth is also in use, in which the tooth dimensions are based upon circular pitch. The addendum is  $0.250 \times$  circular pitch, and the dedendum is  $0.300 \times$  circular pitch. The former system is the one in more general use.

**Stepped Gears.** — Two gears of the same pitch and diameter mounted side by side on the same shaft will act as a single gear. If one gear is keyed on the shaft so that the teeth of the two wheels are not in line, but the teeth of one wheel slightly in advance of the other, the two gears form a stepped gear. If mated with a similar stepped gear on a parallel shaft the number of teeth in contact will be twice as great as in an ordinary gear, which will increase the strength of the gear and its smoothness of action.

**Twisted Teeth.** — If a great number of very thin gears were placed together, one slightly in advance of the other, they would still act as a stepped gear. Continuing the subdivision until the thickness of each separate gear is infinitesimal, the faces of the teeth instead of being in steps take the form of a spiral or twisted surface, and we have a twisted gear. The twist may take any shape, and if it is in one direction for half the width of the gear and in the opposite direction for the other half, we have what is known as the herring-bone or double helical tooth. The obliquity of the twisted tooth if twisted in one direction causes an end thrust on the shaft, but if the herring-bone twist is used, the opposite obliquities neutralize each other. This form of tooth is much used in heavy rolling-mill practice, where great strength and resistance to shocks are necessary. They are frequently made of steel castings (Fig. 185). The angle of the tooth with a line parallel to the axis of the gear is usually  $30^\circ$ .

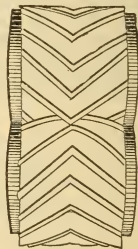

FIG. 185.

**Spiral or Helical Gears.** — If a twisted gear has a uniform twist it becomes what is commonly called a spiral gear (properly a helical gear). The line in which the pitch-surface intersects the face of the tooth is part of a helix drawn on the pitch-surface. A spiral wheel may be made with only one helical tooth wrapped around the cylinder several times, in which it becomes a screw or worm. If it has two or three teeth so wrapped, it is a double- or triple-threaded screw or worm. A spiral-gear meshing into a rack is used to drive the table of some forms of planing-machine. For methods of laying out and producing spiral gears see Brown and Sharpe's treatise on Gearing and Halsey's Worm and Spiral Gearing, also Machy., May 1906 and Machy's Reference Series No. 20.

**Worm-gearing.** — When the axes of two spiral gears are at right angles, and a wheel of one, two, or three threads works with a larger wheel of many threads, it becomes a worm-gear, or endless screw, the smaller wheel or driver being called the worm, and the larger, or driven wheel, the worm-wheel. With this arrangement a high velocity ratio may be obtained with a single pair of wheels. For a one-threaded wheel the velocity ratio is the number of teeth in the worm-wheel. The worm and wheel are commonly so constructed that the worm will drive the wheel, but the wheel will not drive the worm.

To find the diameter of a worm-wheel at the throat, number of teeth and pitch of the worm being given: Add 2 to the number of teeth, multiply the sum by 0.3183, and by the pitch of the worm in inches.

To find the number of teeth, diameter at throat and pitch of worm being given: Divide 3.1416 times the diameter by the pitch, and subtract 2 from the quotient.

In Fig. 186  $ab$  is the diam. of the pitch-circle,  $cd$  is the diam. at the throat.

EXAMPLE. — Pitch of

worm  $\frac{1}{4}$  in., number of teeth 70; required the diam. at the throat.  $(70 + 2) \times 0.3183 \times 0.25 = 5.73$  in.

For design of worm gearing see Kimball and Barr's Machine Design. For efficiency of worm-gears see page 1171.

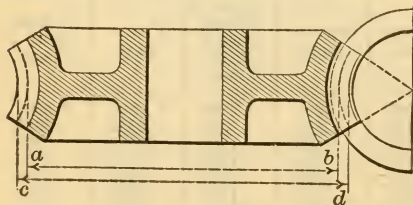

FIG. 186.



**The Hindley Worm.** — In the Hindley worm-gear the worm, instead of being cylindrical in outline, is of an hour-glass shape, the pitch line of the worm being a curved line corresponding to the pitch line of the gear. It is claimed that there is surface contact between the faces of the teeth of the worm and gear, instead of only line contact as in the case of the ordinary worm gear, but this is denied by some writers. For discussion of the Hindley worm see *Am. Mach.*, April 1, 1897 and *Machy.*, Dec. 1908. The Hindley gear is made by the Albro-Clem Elevator Co., Philadelphia.

**Teeth of Bevel-wheels.** (Rankine's Machinery and Millwork.) — The teeth of a bevel-wheel have acting surfaces of the conical kind, generated by the motion of a line traversing the apex of the conical pitch-surface, while a point in it is carried round the traces of the teeth upon a spherical surface described about that apex.

The operations of drawing the traces of the teeth of bevel-wheels exactly, whether by involutes or by rolling curves, are in every respect analogous to those for drawing the traces of the teeth of spur-wheels; except that in the case of bevel-wheels all those operations are to be performed on the surface of a sphere described about the apex, instead of on a plane, substituting poles for centers and great circles for straight lines.

In consideration of the practical difficulty, especially in the case of large wheels, of obtaining an accurate spherical surface, and of drawing upon it when obtained, the following approximate method, proposed originally by Tredgold, is generally used:

Let  $O$ , Fig. 187, be the common apex of the pitch-cones,  $OB$ ,  $OB'$ , of a pair of bevel-wheels;  $OC$ ,  $OC'$ , the axes of those cones;  $OI$  their line of contact. Perpendicular to  $OI$  draw  $AIA'$ , cutting the axes in  $A$ ,  $A'$ ; make the outer rims of the patterns and of the wheels portions of the cones  $ABI$ ,  $A'B'I$ , of which the narrow zones occupied by the teeth will be sufficiently near for practical purposes to a spherical surface described about  $O$ . As the cones  $ABI$ ,  $A'B'I$  cut the pitch-

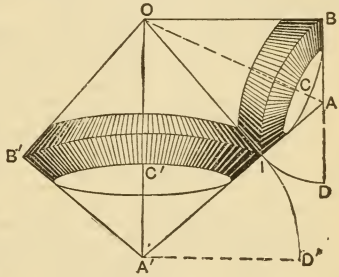

FIG. 187.

cones at right angles in the outer pitch-circles  $IB$ ,  $IB'$ , they may be called the normal cones. To find the traces of the teeth upon the normal cones, draw on a flat surface circular arcs,  $ID$ ,  $ID'$ , with the radii  $AI$ ,  $A'I$ ; those arcs will be the developments of arcs of the pitch-circles  $IB$ ,  $IB'$  when the conical surfaces  $ABI$ ,  $A'B'I$  are spread out flat. Describe the traces of teeth for the developed arcs as for a pair of spur-wheels, then wrap the developed arcs on the normal cones, so as to make them coincide with the pitch-circles, and trace the teeth on the conical surfaces.

For formulæ and instructions for designing bevel-gears, and for much other valuable information on the subject of gearing, see "Practical Treatise on Gearing," and "Formulas in Gearing," published by Brown & Sharpe Mfg. Co.; and "Teeth of Gears," by George B. Grant, Lexington, Mass. The student may also consult Rankine's Machinery and Millwork, Reuleaux's Constructor, and Unwin's Elements of Machine Design. See also article on Gearing, by C. W. MacCord in *App. Cyc. Mech.*, vol. ii.

**Annular and Differential Gearing.** (S. W. Balch, *Am. Mach.*, Aug. 24, 1893.) — In internal gears the sum of the diameters of the describing circles for faces and flanks should not exceed the difference in the pitch diameters of the pinion and its internal gear. The sum may be equal to this difference or it may be less; if it is equal, the faces of the teeth of each wheel will drive the faces as well as the flanks of the teeth of the other wheel. The teeth will therefore make contact with each other at two points at the same time.

Cycloidal tooth-curves for interchangeable gears are formed with describing circles of about  $\frac{5}{8}$  the pitch diameter of the smallest gear of the series. To admit two such circles between the pitch-circles of the pinion and internal gear the number of teeth in the internal gear should exceed

the number in the pinion by 12 or more, if the teeth are of the customary proportions and curvature used in interchangeable gearing.

Very often a less difference is desirable, and the teeth may be modified in several ways to make this possible.

*First.* The tooth curves resulting from smaller describing circles may be employed. These will give teeth which are more rounding and narrower at their tops, and therefore not as desirable as the regular forms.

*Second.* The tips of the teeth may be rounded until they clear. This is a cut-and-try method which aims at modifying the teeth to such outlines as smaller describing circles would give.

*Third.* One of the describing circles may be omitted and one only used, which may be equal to the difference between the pitch-circles. This will permit the meshing of gears differing by six teeth. It will usually prove inexpedient to put wheels in inside gears that differ by much less than 12 teeth.

If a regular diametral pitch and standard tooth forms are determined on, the diameter to which the internal gear-blank is to be bored is calculated by subtracting 2 from the number of teeth, and dividing the remainder by the diametral pitch.

The tooth outlines are the match of a spur-gear of the same number of teeth and diametral pitch, so that the spur-gear will fit the internal gear as a punch fits its die, except that the teeth of each should fail to bottom in the tooth spaces of the other by the customary clearance of one-tenth the thickness of the tooth.

Internal gearing is particularly valuable when employed in differential action. This is a mechanical movement in which one of the wheels is mounted on a crank so that its center can move in a circle about the center of the other wheel. Means are added which restrain the wheel on the crank from turning over and confine it to the revolution of the crank.

The ratio of the number of teeth in the revolving wheel compared with the difference between the two will represent the ratio between the revolving wheel and the crank-shaft by which the other is carried. The advantage in accomplishing the change of speed with such an arrangement, as compared with ordinary spur-gearing, lies in the almost entire absence of friction and consequent wear of the teeth.

But for the limitation that the difference between the wheels must not be too small, the possible ratio of speed might be increased almost indefinitely, and one pair of differential gears made to do the service of a whole train of wheels. If the problem is properly worked out with bevel-gears this limitation may be completely set aside, and external and internal bevel-gears, differing by but a single tooth if need be, made to mesh perfectly with each other.

### EFFICIENCY OF GEARING.

An extensive series of experiments on the efficiency of gearing, chiefly worm and spiral gearing, is described by Wilfred Lewis in *Trans. A. S. M. E.*, vii, 273. The average results are shown in a diagram, from which the following approximate average figures are taken:

EFFICIENCY OF SPUR, SPIRAL, AND WORM-GEARING.

Gearing.	Pitch.	Velocity at pitch-line in feet per min.				
		3	10	40	100	200
Spur pinion.....	.....	0.90	0.935	0.97	0.98	0.985
Spiral pinion.....	45°	.81	.87	.93	.955	.965
“ “.....	30	.75	.815	.89	.93	.945
“ “.....	20	.67	.75	.845	.90	.92
“ “.....	15	.61	.70	.805	.87	.90
Spiral pinion or worm.....	10	.51	.615	.74	.82	.86
“ “.....	7	.43	.53	.72	.765	.815
“ “.....	5	.34	.43	.60	.70	.765

The experiments showed the advantage of spur-gearing over all other kinds in both durability and efficiency. The variation from the mean results rarely exceeded 5% in either direction, so long as no cutting occurred, but the variation became much greater and very irregular as soon as cutting began. The loss of power varies with the speed, the

pressure, the temperature, and the condition of the surfaces. The high friction of worm- and spiral-gearing is largely due to end thrust on the collars of the shaft, and may be considerably reduced by roller-bearings for the collars.

When two worms with opposite spirals run in two spiral worm-gears that also work with each other, and the pressure on one gear is opposite that on the other, there is no thrust on the shaft. Even with light loads a worm will begin to heat and cut if run at too high a speed, the limit for safe working being a velocity of the rubbing surfaces of 200 to 300 ft. per minute, the former being preferable where the gearing has to work continuously. The wheel teeth will keep cool, as they form part of a casting having a large radiating surface; but the worm itself is so small that its heat is dissipated slowly. Whenever the heat generated increases faster than it can be conducted and radiated away, the cutting of the worm may be expected to begin. A low efficiency for a worm-gear means more than the loss of power, since the power which is lost reappears as heat and may cause the rapid destruction of the worm.

Unwin (Elements of Machine Design, p. 294) says: The efficiency is greater the less the radius of the worm. Generally the radius of the worm = 1.5 to 3 times the pitch of the thread of the worm or the circular pitch of the worm-wheel. For a one-threaded worm the efficiency is only 2/5 to 1/4; for a two-threaded worm, 4/7 to 2/5; for a three-threaded worm, 2/3 to 1/2. As so much work is wasted in friction it is natural that the wear is excessive. The table below gives the calculated efficiencies of worm-wheels of 1, 2, 3, and 4 threads and ratios of radius of worm to pitch of teeth of from 1 to 6, with a coefficient of friction of 0.15.

No. of Threads.	Radius of Worm ÷ Pitch.								
	1	1 1/4	1 1/2	1 3/4	2	2 1/2	3	4	6
1	0.50	0.44	0.40	0.36	0.33	0.28	0.25	0.20	0.14
2	.67	.62	.57	.53	.50	.44	.40	.33	.25
3	.75	.70	.67	.63	.60	.55	.50	.43	.33
4	.80	.76	.73	.70	.67	.62	.57	.50	.40

**Efficiency of Worm Gearing.** — Worm gearing as a means of transmitting power has generally been looked upon with suspicion, its efficiency being considered necessarily low and its life short. When properly proportioned, however, it is both durable and reasonably efficient. Mr. F. A. Halsey discusses the subject in *Am. Machinist*, Jan. 13 and 20, 1898. He quotes two formulas for the efficiency of worm gearing:

$$E = \frac{\tan \alpha (1 - f \tan \alpha)}{\tan \alpha + f}, \dots (1) \quad E = \frac{\tan \alpha (1 - f \tan \alpha)}{\tan \alpha + 2f} \text{ approx.} \dots (2)$$

In which  $E$  = efficiency;  $\alpha$  = angle of thread, being angle between thread and a line perpendicular to the axis of the worm;  $f$  = coefficient of friction.

Eq. (1) applies to the worm thread only, while (2) applies to the worm and step combined, on the assumption that the mean friction radius of the two is equal. Eq. (1) gives a maximum for  $E$  when  $\tan \alpha = \sqrt{1 + f^2} - f$  . . . (3) and eq. (2) a maximum when  $\tan \alpha = \sqrt{2 + 4f^2} - 2f$  . . . (4) Using 0.05 for  $f$  gives  $\alpha$  in (3) = 43° 34' and in (4) = 52° 49'.

On plotting equations (1) and (2) the curves show the striking influence of the pitch-angle upon the efficiency, and since the lost work is expended in friction and wear, it is plain why worms of low angle should be short-lived and those of high angle long-lived. The following table is taken from Mr. Halsey's plotted curves:

RELATION OF THREAD-ANGLE, SPEED AND EFFICIENCY OF WORM-GEARS.

Velocity of Pitch-line, Feet per Minute.	Angle of Thread.					
	5	10	20	30	40	45
Efficiency.						
3	35	52	66	73	76	77
5	40	56	69	76	79	80
10	47	62	74	79	82	82
20	52	67	78	83	85	86
40	60	74	83	87	88	88
100	70	82	88	91	91	91
200	76	85	91	92	92	92



The experiments of Mr. Wilfred Lewis on worms show a very satisfactory correspondence with the theory. Mr. Halsey gives a collection of data comprising 16 worms doing heavy duty and having pitch-angles ranging between  $4^{\circ} 30'$  and  $45^{\circ}$ , which show that every worm having an angle above  $12^{\circ} 30'$  was successful in regard to durability, and every worm below  $9^{\circ}$  was unsuccessful, the overlapping region being occupied by worms some of which were successful and some unsuccessful. In several cases worms of one pitch-angle had been replaced by worms of a different angle, an increase in the angle leading in every case to better results and a decrease to poorer results. He concludes with the following table from experiments by Mr. James Christie, of the Pencoyd Iron Works, and gives data connecting the load upon the teeth with the pitch-line velocity of the worm.

LIMITING SPEEDS AND PRESSURES OF WORM GEARING.

	Single-thread Worm 1" Pitch, $2\frac{7}{8}$ Pitch Diam.				Double- thread Worm 2" Pitch, $2\frac{7}{8}$ Pitch Diam.			Double- thread Worm $2\frac{1}{2}$ " Pitch, $4\frac{1}{2}$ Pitch Diam.		
	128	201	272	425	128	201	272	201	272	425
Revolutions per minute.....	128	201	272	425	128	201	272	201	272	425
Velocity at pitch-line, feet per minute.....	96	150	205	320	96	150	205	235	319	498
Limiting pressure, pounds.....	1700	1300	1100	700	1100	1100	1100	1100	700	400

**Efficiency of Automobile Gears.** (G. E. Quick, *Horseless Age*, Feb. 12, 1908.)—A set of slide gears was tested by an electric-driven absorption dynamometer. The following approximate results are taken from a series of plotted curves:

Horse-power input.....	r.p.m.	2	4	6	8	10	14	18
		Efficiency, per cent.						
Direct driven, third speed.....	800	89	95	97	97.5	97.5	97.5	96
Direct driven, third speed.....	1,500	80	89	93	95	96.5	97	97
Second speed, ratio 1.76 to 1 ...	800	87	92.5	94	95	94	93	.....
Second speed, ratio 1.76 to 1 ...	1,500	79	88	92.5	94	95	95	94
First speed, ratio 3.36 to 1.....	800	75	87.5	93	94	94	93.5	92.5
First speed, ratio 3.36 to 1.....	1,500	70	84	89	92	93	92	.....
Reverse speed, ratio 4.32 to 1...	800	75	84	87	87	86	82.5	.....
Reverse speed, ratio 4.32 to 1...	1,500	.....	70	79	83	86	87	85
Worm-gear axle, ratio 6.83 to 1..	400	85	87	86.5	85.5	84	80	75
Worm-gear axle, ratio 6.83 to 1..	800	83	87	88.5	89	89	88	87
Worm-gear axle, ratio 6.83 to 1..	1,500	80	85	87.5	88.5	89	89	89

Two bevel-wheel axles were tested, one a floating type, ratio 15 to 32,  $14\frac{1}{2}^{\circ}$  involute; the other a solid wheel and axle type, ratio 13 to 54,  $20^{\circ}$  involute. Both gave efficiencies of 95 to 96% at 800 to 1500 r.p.m., and 10 to 26 H.P., with lower efficiencies at lower power and at lower speed. The friction losses include those of the journals and thrust ball bearings.

The worm was 6-threaded, lead, 4.69 in.; pitch diam., 2.08 in.; the gear had 41 teeth; pitch diam., 10.2 in. The worm was of hardened steel and the gear of phosphor-bronze. A test of a steel gear and steel worm gave somewhat lower efficiencies. In both tests the heating was excessive both in the gears and in the thrust bearings, the balls in which were  $\frac{7}{16}$  in. diam.

### STRENGTH OF GEAR-TEETH.

The strength of gear-teeth and the horse-power that may be transmitted by them depend upon so many variable and uncertain factors that it is not surprising that the formulas and rules given by different writers show a wide variation. In 1879 John H. Cooper (*Jour. Frank. Inst.*, July, 1879) found that there were then in existence about 48 well-established rules for horse-power and working strength, differing from each other in extreme cases about 500%. In 1886 Prof. Wm. Harkness (*Proc. A. A. S.*, 1886), from an examination of the bibliography of the subject, beginning in 1796, found that according to the constants and

formulae used by various authors there were differences of 15 to 1 in the power which could be transmitted by a given pair of geared wheels. The various elements which enter into the constitution of a formula to represent the working strength of a toothed wheel are the following: 1. The strength of the metal, usually cast iron, which is an extremely variable quantity. 2. The shape of the tooth, and especially the relation of its thickness at the root or point of least strength to the pitch and to the length. 3. The point at which the load is taken to be applied, assumed by some authors to be at the pitch-line, by others at the extreme end, along the whole face, and by still others at a single outer corner. 4. The consideration of whether the total load is at any time received by a single tooth or whether it is divided between two teeth. 5. The influence of velocity in causing a tendency to break the teeth by shock. 6. The factor of safety assumed to cover all the uncertainties of the other elements of the problem.

Prof. Harkness, as a result of his investigation, found that all the formulae on the subject might be expressed in one of three forms, viz.:

$$\text{Horse-power} = CVpf, \text{ or } CVp^2, \text{ or } CVp^2f;$$

in which  $C$  is a coefficient,  $V$  = velocity of pitch-line in feet per second,  $p$  = pitch in inches, and  $f$  = face of tooth in inches.

From an examination of precedents he proposed the following formula for cast-iron wheels:

$$\text{H.P.} = \frac{0.910 Vpf}{\sqrt{1 + 0.65 V}}$$

He found that the teeth of chronometer and watch movements were subject to stresses four times as great as those which any engineer would dare to use in like proportion upon cast-iron wheels of large size.

It appears that all of the earlier rules for the strength of teeth neglected the consideration of the variations in their form; the breaking strength, as said by Mr. Cooper, being based upon the thickness of the teeth at the pitch-line or circle, as if the thickness at the root of the tooth were the same in all cases as it is at the pitch-line.

Wilfred Lewis (*Proc. Eng'rs Club, Phila.*, Jan., 1893; *Am. Mach.*, June 22, 1893) seems to have been the first to use the form of the tooth in the construction of a working formula and table. He assumes that in well-constructed machinery the load can be more properly taken as well distributed across the tooth than as concentrated in one corner, but that it cannot be safely taken as concentrated at a maximum distance from the root less than the extreme end of the tooth. He assumes that the whole load is taken upon one tooth, and considers the tooth as a beam loaded at one end, and from a series of drawings of teeth of the involute, cycloidal, and radial flank systems, determines the point of weakest cross-section of each, and the ratio of the thickness at that section to the pitch. He thereby obtains the general formula,

$$W = spfy;$$

In which  $W$  is the load transmitted by the teeth, in pounds;  $s$  is the safe working stress of the material, taken at 8000 lbs. for cast iron, when the working speed is 100 ft. or less per minute;  $p$  = pitch;  $f$  = face, in inches;  $y$  = a factor depending on the form of the tooth, whose value for different cases is given in the table on page 1174.

The values of  $s$  in the above table are given by Mr. Lewis tentatively, in the absence of sufficient data upon which to base more definite values, but they have been found to give satisfactory results in practice.

**EXAMPLE.** Required to find the working strength of a 12-toothed pinion, 1-inch pitch,  $2\frac{1}{2}$ -inch face, driving a wheel of 60 teeth at 100 feet or less per minute, and let the teeth be of the 20-degree involute form. In the formula  $W = spfy$  we have for a cast-iron pinion  $s = 8000$ ,  $pf = 2.5$ , and  $y = 0.078$ ; and multiplying these values together, we have  $W = 1560$  pounds. For the wheel we have  $y = 0.134$  and  $W = 2680$  pounds.

The cast-iron pinion is, therefore, the measure of strength; but if a steel pinion be substituted we have  $s = 20,000$  and  $W = 3900$  pounds, in which combination the wheel is the weaker, and it therefore becomes the measure of strength.

For bevel-wheels Mr. Lewis gives the following, referring to Fig. 188:

$D$  = large diameter of bevel;  $d$  = small diameter of bevel;  $p$  = pitch at large diameter;  $n$  = actual number of teeth;  $f$  = face of bevel;  $N$  = formative number of teeth =  $n \times \secant a$ , or the number corresponding to radius  $R$ ;  $y$  = factor depending upon shape of teeth and formative number  $N$ ;  $W$  = working load on teeth, assumed to be applied at the large end of the bevel gear on the pitch line.

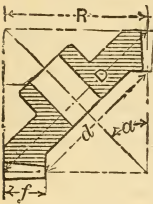

FIG. 188.

$$W = spfy \frac{D^3 - d^3}{3D^2(D - d)}; \text{ or, more simply, } W = spfy \frac{d}{D};$$

which gives almost identical results when  $d$  is not less than  $\frac{2}{3} D$ , as is the case in good practice.

In *Am. Mach.*, June 22, 1893, Mr. Lewis gives the following formulæ for the working strength of the three systems of gearing, which agree very closely with those obtained by use of the table:

For involute, 20° obliquity,  $W = spf \left( 0.154 - \frac{0.912}{n} \right);$

For involute 15°, and cycloidal,  $W = spf \left( 0.124 - \frac{0.684}{n} \right);$

For radial flank system,  $W = spf \left( 0.075 - \frac{0.276}{n} \right);$

in which the factor within the parenthesis corresponds to  $y$  in the general formula. For the horse-power transmitted, Mr. Lewis's general formula

$$W = spfy = \frac{33,000 \text{ H.P.}}{v}, \text{ may take the form } \text{H.P.} = \frac{spfyv}{33,000},$$

in which  $v$  = velocity in feet per minute; or since  $v = d\pi \times \text{r.p.m.} \div 12 = 0.2618 d \times \text{r.p.m.}$ , in which  $d$  = diameter in inches,

$$\text{H.P.} = \frac{Wv}{33,000} = \frac{spfy \times d \times \text{r.p.m.}}{126,050} = 0.000007933 dspfy \times \text{r.p.m.}$$

It must be borne in mind, however, that in the case of machines which consume power intermittently, such as punching and shearing machines, the gearing should be designed with reference to the maximum load  $W$ , which can be brought upon the teeth at any time, and not upon the average horse-power transmitted.

VALUES OF  $y$  IN LEWIS'S FORMULA.

No. of Teeth.	Factor for Strength, $y$ .			No. of Teeth.	Factor for Strength, $y$ .		
	Involute 20° Obliquity.	Involute 15° and Cycloidal	Radial Flanks.		Involute 20° Obliquity.	Involute 15° and Cycloidal	Radial Flanks.
12	0.078	0.067	0.052	27	0.111	0.100	0.064
13	.083	.070	.053	30	.114	.102	.065
14	.088	.072	.054	34	.118	.104	.066
15	.092	.075	.055	38	.122	.107	.067
16	.094	.077	.056	43	.126	.110	.068
17	.096	.080	.057	50	.130	.112	.069
18	.098	.083	.058	60	.134	.114	.070
19	.100	.087	.059	75	.138	.116	.071
20	.102	.090	.060	100	.142	.118	.072
21	.104	.092	.061	150	.146	.120	.073
23	.106	.094	.062	300	.150	.122	.074
25	.108	.097	.063	Rack.	.154	.124	.075

SAFE WORKING STRESS,  $s$ , FOR DIFFERENT SPEEDS.

Speed of Teeth in Ft. per Minute.	100 or less.	200	300	600	900	1200	1800	2400
Cast iron.....	8000	6000	4800	4000	3000	2400	2000	1700
Steel.....	20000	15000	12000	10000	7500	6000	5000	4300

Comparison of the Harkness and Lewis Formulæ.—Take an average case in which the safe working strength of the material,  $s = 6000$ ,



$v = 200$  ft. per min., and  $y = 0.100$ , the value in Mr. Lewis's table for an involute tooth of  $15^\circ$  obliquity, or a cycloidal tooth, the number of teeth in the wheel being 27.

$$\text{H.P.} = \frac{spfyv}{33,000} = \frac{6000 pfv \times 0.100}{33,000} = \frac{pfv}{55} = 1.091 pfV,$$

if  $V$  is taken in feet per second.

Prof. Harkness gives  $\text{H.P.} = \frac{0.910 Vpf}{\sqrt{1 + 0.65 V}}$ . If the  $V$  in the denominator

be taken at  $200 \div 60 = 3\frac{1}{3}$  ft. per sec.,  $\text{H.P.} = 0.571 pfV$ , or about 52% of the result given by Mr. Lewis's formula. This is probably as close an agreement as can be expected, since Prof. Harkness derived his formula from an investigation of ancient precedents and rule-of-thumb practice, largely with common cast gears, while Mr. Lewis's formula was derived from considerations of modern practice with machine-molded and cut gears.

Mr. Lewis takes into consideration the reduction in working strength of a tooth due to increase in velocity by the figures in his table of the values of the safe working stress  $s$  for different speeds. Prof. Harkness gives expression to the same reduction by means of the denominator of his formula,  $\sqrt{1 + 0.65 V}$ . The decrease in strength as computed by this formula is somewhat less than that given in Mr. Lewis's table, and as the figures given in the table are not based on accurate data, a mean between the values given by the formula and the table is probably as near to the true value as may be obtained from our present knowledge. The following table gives the values for different speeds according to Mr. Lewis's table and Prof. Harkness's formula, taking for a basis a working stress  $s$ , for cast-iron 8000, and for steel 20,000 lbs. at speeds of 100 ft. per minute and less:

$v =$ speed of teeth, ft. per min..	100	200	300	600	900	1200	1800	2400
$V =$ speed of teeth, ft. per sec..	$1\frac{2}{3}$	$3\frac{1}{3}$	5	10	15	20	30	40
Safe stress $s$ , cast iron, Lewis ..	8000	6000	4800	4000	3000	2400	2000	1700
Relative do., $s \div 8000$ .....	1	0.75	0.6	0.5	0.375	0.3	0.25	0.2125
$1 \div \sqrt{1 + 0.65 V}$ .....	.6930	.5621	.4850	.3650	.3050	.2672	.2208	.1924
Relative val. $c \div 0.693$ .....	1	0.811	0.700	0.526	0.439	0.385	0.318	0.277
$s_1 = 8000 \times (c \div 0.693)$ .....	8000	6488	5600	4208	3512	3080	2544	2216
Mean of $s$ and $s_1$ , cast-iron = $s_2$ ..	8000	6200	5200	4100	3300	2700	2300	2000
Mean of $s$ and $s_1$ , for steel = $s_3$ ..	20000	15500	13000	10300	8100	6800	5700	4900
Safe stress for steel, Lewis.....	20000	15000	12000	10000	7500	6000	5000	4300

In *Am. Mach.*, Jan. 30, 1902, Mr. Lewis says that 8,000 lbs. was given as safe for cast-iron teeth, either cut or cast, and that 20,000 lbs. was intended for any steel suitable for gearing whether cast or forged. These were the unit stresses for static loads.

The iron should be of good quality capable of sustaining about a ton on a test bar 1 in. square between supports 12 in. apart, and the steel should be solid and of good quality. The value given for steel was intended to include the lower grades, but when the quality is known to be high, correspondingly higher values may be assigned.

Comparing the two formulæ for the case of  $s = 8000$ , corresponding to a speed of 100 ft. per min., we have

Harkness:  $\text{H.P.} = 1 \div \sqrt{1 + 0.65 V} \times 0.910 Vpf = 1.053 pf$ ,

Lewis:  $\text{H.P.} = \frac{spfyv}{33,000} = \frac{spfy V}{550} = \frac{8000 \times 1\frac{2}{3} pfy}{550} = 24.24 pfy$ ,

in which  $y$  varies according to the shape and number of the teeth.

For radial-flank gear with 12 teeth  $y = 0.052$ ;  $24.24 pfy = 1.260 pf$ ;  
 For  $20^\circ$  inv., 19 teeth, or  $15^\circ$  inv., 27 teeth  $y = 0.100$ ;  $24.24 pfy = 2.424 pf$ ;  
 For  $20^\circ$  involute, 300 teeth  $y = 0.150$ ;  $24.24 pfy = 3.636 pf$ .

Thus the weakest-shaped tooth, according to Mr. Lewis, will transmit 20 per cent more horse-power than is given by Prof. Harkness's formula, in which the shape of the tooth is not considered, and the average-shaped

tooth, according to Mr. Lewis, will transmit more than double the horse-power given by Prof. Harkness's formula.

**Comparison of Other Formulæ.**—Mr. Cooper, in summing up his examination, selected an old English rule, which Mr. Lewis considers as a passably correct expression of good general averages, viz.:  $X = 2000 pf$ ,  $X$  = breaking load of tooth in pounds,  $p$  = pitch,  $f$  = face. If a factor of safety of 10 be taken, this would give for safe working load  $W = 200 pf$ .

George B. Grant, in his *Teeth of Gears*, page 33, takes the breaking load at 3500  $pf$ , and, with a factor of safety of 10, gives  $W = 350 pf$ .

Nystrom's *Pocket-Book*, 20th ed., 1891, says: "The strength and durability of cast-iron teeth require that they shall transmit a force of 80 lbs. per inch of pitch and per inch breadth of face." This is equivalent to  $W = 80 pf$ , or only 40% of that given by the English rule.

F. A. Halsey (*Clark's Pocket-Book*) gives a table calculated from the formula  $H.P. = pfd \times r.p.m. \div 850$ .

Jones & Laughlins give  $H.P. = pfd \times r.p.m. \div 550$ .

These formulæ transformed give  $W = 128 pf$  and  $W = 218 pf$ , respectively.

Unwin, on the assumption that the load acts on the corners of the teeth, derives a formula  $p = K \sqrt{W}$ , in which  $K$  is a coefficient derived from existing wheels, its values being: for slowly moving gearing not subject to much vibration or shock  $K = 0.04$ ; in ordinary mill-gearing, running at greater speed and subject to considerable vibration,  $K = 0.05$ ; and in wheels subjected to excessive vibration and shock, and in mortise gearing,  $K = 0.06$ . Reduced to the form  $W = Cpf$ , assuming that  $f = 2p$ , these values of  $K$  give  $W = 262 pf$ ,  $200 pf$ , and  $139 pf$ , respectively.

Unwin also give the following, based on the assumption that the pressure is distributed along the edge of the tooth:  $p = K_1 \sqrt{p/f} \sqrt{W}$ , where  $K_1 = \text{about } 0.0707$  for iron wheels and  $0.0848$  for mortise wheels when the breadth of face is not less than twice the pitch. For the case of  $f = 2p$  and the given values of  $K_1$  this reduces to  $W = 200 pf$  and  $W = 139 pf$ , respectively.

Box, in his *Treatise on Mill Gearing*, gives  $H.P. = 12 p^2 f \sqrt{dn} \div 1000$ , in which  $n$  = number of revolutions per minute. This formula differs from the more modern formulæ in making the H.P. vary as  $p^2 f$ , instead of as  $pf$ , and in this respect it is no doubt incorrect.

Making the H.P. vary as  $\sqrt{dn}$  or as  $\sqrt{v}$ , instead of directly as  $v$ , makes the velocity a factor of the working strength as in the Harkness and Lewis formulæ, the relative strength varying as  $1/\sqrt{v}$ , which for different velocities is as follows:

Speed of teeth in ft. per min., $v =$	}	100	200	300	600	900	1200	1800	2400
Relative strength =		1	0.707	0.574	0.408	0.333	0.289	0.236	0.20

showing a somewhat more rapid reduction than is given by Mr. Lewis.

For the purpose of comparing different formulæ they may in general be reduced to either of the following forms:

$$H.P. = Cpfv, \quad H.P. = C_1 pfd \times r.p.m., \quad W = cpf,$$

in which  $p$  = pitch,  $f$  = face,  $d$  = diameter, all in inches;  $v$  = velocity in feet per minute, r.p.m. revolutions per minute, and  $C$ ,  $C_1$  and  $c$  coefficients. The formulæ for transformation are as follows:

$$H.P. = Wv \div 33,000 = W \times d \times r.p.m. \div 126,050;$$

$$W = \frac{33,000 H.P.}{v} = \frac{126,050 H.P.}{d \times r.p.m.} = 33,000 Cpf; \quad pf = \frac{H.P.}{Cv} = \frac{H.P.}{C_1 d \times r.p.m.} = \frac{W}{c}$$

$$C_1 = 0.2618 C; \quad c = 33,000 C; \quad C = 3.82 C_1, \quad = \frac{c}{33,000}; \quad c = 126,050 C_1.$$

In the Lewis formula  $C$  varies with the form of the tooth and with the speed, and is equal to  $sy \div 33,000$ , in which  $y$  and  $s$  are the values taken from the table, and  $c = sy$ .

In the Harkness formula  $C$  varies with the speed and is equal to

$$\frac{910}{\sqrt{1 + 0.65 V}} \quad (V \text{ being in feet per second}), = 0.01517 \div \sqrt{1 + 0.011 v}.$$

In the Box formula  $C$  varies with the pitch and also with the velocity, and equals  $\frac{12 p \sqrt{d} \times \text{r.p.m.}}{1000 v} = 0.02345 \frac{p}{\sqrt{v}}$ ,  $c = 33,000 C = 774 \frac{p}{\sqrt{v}}$ .

For  $v = 100$  ft. per min.  $C = 77.4 p$ ; for  $v = 600$  ft. per min.,  $c = 31.6 p$ . In the other formulæ considered  $C$ ,  $C_1$ , and  $c$  are constants. Reducing the several formulæ to the form  $W = cpf$ , we have the following:

COMPARISON OF DIFFERENT FORMULÆ FOR STRENGTH OF GEAR-TEETH.

Safe working pressure per inch pitch and per inch of face, or value of  $c$  in formula  $W = cpf$ :

	$v =$ ft. per min.	100	600
Lewis: Weak form of tooth, radial flank, 12 teeth	$c =$	416	208
Medium tooth, inv. $15^\circ$ , or cycloid, 27 teeth	$c =$	800	400
Strong form of tooth, inv. $20^\circ$ , 300 teeth	$c =$	1200	600
Harkness: Average tooth	$c =$	347	184
Box: Tooth of 1 inch pitch	$c =$	77.4	31.6
Box: Tooth of 3 inches pitch	$c =$	232	95

The Gleason Works gives for ft. per min.	500	1000	1500	2000	2500
working stress in pounds = p.f. $\times$	480	400	340	290	240

These are for cut gears, 18 teeth or more, rigidly supported, for average steady loads. Hammering loads, as in rolling mills and saw mills, require heavier gears.

C. W. Hunt, *Trans. A.S.M.E.*, 1908, gives a table of working loads of cut cast gears with a strong short form of tooth, which is practically equivalent to  $W = 700 pf$ .

Various, in which  $c$  is independent of form and speed: Old English rule,  $c = 200$ ; Grant,  $c = 350$ ; Nystrom,  $c = 80$ ; Halsey,  $c = 128$ ; Jones & Laughlins,  $c = 218$ ; Unwin,  $c = 262, 200, \text{ or } 139$ , according to speed, shock, and vibration.

The value given by Nystrom and those given by Box for teeth of small pitch are so much smaller than those given by the other authorities that they may be rejected as having an entirely unnecessary surplus of strength. The values given by Mr. Lewis seem to rest on the most logical basis, the form of the teeth as well as the velocity being considered; and since they are said to have proven satisfactory in an extended machine practice, they may be considered reliable for gears that are so well made that the pressure bears along the face of the teeth instead of upon the corners. For rough ordinary work the old English rule  $W = 200 pf$  is probably as good as any, except that the figure 200 may be too high for weak forms of tooth and for high speeds.

The formula  $W = 200 pf$  is equivalent to  $\text{H.P.} = pfd \times \text{r.p.m.} \div 630 = pfv \div 165$  or,  $\text{H.P.} = 0.0015873 pfd \times \text{r.p.m.} = 0.006063 pfv$ .

**Raw-hide Pinions.** — Pinions of raw-hide are in common use for gearing shafts driven by electric motors to other shafts which carry machine-cut cast-iron or steel gears, in order to reduce vibration, noise and wear. A formula for the maximum horse-power to be transmitted by such gears, given by the New Process Raw-Hide Co., Syracuse, N. Y., is  $\text{H.P.} = \text{pitch diam.} \times \text{circ. pitch} \times \text{face} \times \text{r.p.m.} \div 850$ , or  $pfd \times \text{r.p.m.} \div 850$ . This is about  $\frac{3}{4}$  of the H.P. for cast-iron teeth by the old English rule. The formula is to be used only when the circular pitch does not exceed 1.65 ins.

Composite gears also are made, consisting of alternate sheets of raw-hide or fibre and steel or bronze, so that a high degree of strength is combined with the smooth-running quality of the fibre.

**Maximum Speed of Gearing.** — A. Towler, *Eng'g*, April 19, 1889, p. 388, gives the maximum speeds at which it was possible under favorable conditions to run toothed gearing safely as follows, in ft. per min.: Ordinary cast-iron wheels, 1800; Helical, 2400; Mortise, 2400; Ordinary cast-steel wheels, 2600; Helical, 3000; special cast-iron machine-cut wheels, 3000.

Prof. Coleman Sellers (*Stevens Indicator*, April, 1892) recommends that gearing be not run over 1200 ft. per minute, to avoid great noise. The



Walker Company, Cleveland, Ohio, say that 2200 ft. per min. for iron gears and 3000 ft. for wood and iron (mortise gears) are excessive, and should be avoided if possible. The Corliss engine at the Philadelphia Exhibition (1876) had a fly-wheel 30 ft. in diameter running 35 r.p.m. geared into a pinion 12 ft. diam. The speed of the pitch-line was 3300 ft. per min.

**A Heavy Machine-cut Spur-gear** was made in 1891 by the Walker Company, Cleveland, Ohio, for a diamond mine in South Africa, with dimensions as follows: Number of teeth, 192; pitch diameter, 30 ft. 6.66 ins.; face, 30 ins.; pitch, 6 ins.; bore, 27 ins.; diameter of hub, 9 ft. 2 ins.; weight of hub, 15 tons; and total weight of gear, 66 $\frac{3}{4}$  tons. The rim was made in 12 segments, the joints of the segments being fastened with two bolts each. The spokes were bolted to the middle of the segments and to the hub with four bolts in each end.

**Frictional Gearing.** — In frictional gearing the wheels are toothless, and one wheel drives the other by means of the friction between the two surfaces which are pressed together. They may be used where the power to be transmitted is not very great; when the speed is so high that toothed wheels would be noisy; when the shafts require to be frequently put into and out of gear or to have their relative direction of motion reversed; or when it is desired to change the velocity-ratio while the machinery is in motion, as in the case of disk friction-wheels for changing the feed in machine tools.

Let  $P$  = the normal pressure in pounds at the line of contact by which two wheels are pressed together,  $T$  = tangential resistance of the driven wheel at the line of contact,  $f$  = the coefficient of friction,  $V$  the velocity of the pitch-surface in feet per second, and H.P. = horse-power; then  $T$  may be equal to or less than  $fP$ ; H.P. =  $TV \div 550$ . The value of  $f$  for metal on metal may be taken at 0.15 to 0.20; for wood on metal, 0.25 to 0.30; and for wood on compressed paper, 0.20. The tangential driving force  $T$  may be as high as 80 lbs. per inch width of face of the driving surface, but this is accompanied by great pressure and friction on the journal-bearings.

In frictional grooved gearing circumferential wedge-shaped grooves are cut in the faces of two wheels in contact. If  $P$  = the force pressing the wheels together, and  $N$  = the normal pressure on all the grooves,  $P = N (\sin a + f \cos a)$ , in which  $2a$  = the inclination of the sides of the grooves, and the maximum tangential available force  $T = fN$ . The inclination of the sides of the grooves to a plane at right angles to the axis is usually 30°.

**Frictional Grooved Gearing.** — A set of friction-gears for transmitting 150 H.P. is on a steam-dredge described in *Proc. Inst. M. E.*, July, 1888. Two grooved pinions of 54 in. diam., with 9 grooves of 1 $\frac{3}{4}$  in. pitch and angle of 40° cut on their face, are geared into two wheels of 127 $\frac{1}{2}$  in. diam. similarly grooved. The wheels can be thrown in and out of gear by levers operating eccentric bushes on the large wheel-shaft. The circumferential speed of the wheels is about 500 ft. per min. Allowing for engine friction, if half the power is transmitted through each set of gears the tangential force at the rims is about 3960 lbs., requiring, if the angle is 40° and the coefficient of friction 0.18, a pressure of 7524 lbs. between the wheels and pinion to prevent slipping.

The wear of the wheels proving excessive, the gears were replaced by spur-gear wheels and brake-wheels with steel brake-bands, which arrangement has proven more durable than the grooved wheels. Mr. Daniel Adamson states that if the frictional wheels had been run at a higher speed the results would have been better, and says they should run at least 30 ft. per second.

**Power Transmitted by Friction Drives.** (W. F. M. Goss, *Trans. A. S. M. E.*, 1907.)—A friction drive consists of a fibrous or somewhat yielding driving wheel working in rolling contact with a metallic driven wheel. Such a drive may consist of a pair of plain cylinder wheels mounted upon parallel shafts, or a pair of beveled wheels, or of any other arrangement which will serve in the transmission of motion by rolling contact.

Driving wheels of each of the materials named in the table below were tested in peripheral contact with driving wheels of iron, aluminum and type metal. All the wheels were 16 in. diam.; the face of the driving

wheels was 1 3/4 in., and that of the driven wheels 1/2 in. Records were made of the pressure of contact, of the coefficient of friction developed, and of the percentage of slip resulting from the development of the said coefficient of friction. Curves were plotted showing the relation of the coefficient and the slip for pressures of 150 and 400 lbs. per inch width of face in contact. Another series of tests was made in which the slip was maintained constant at 2% and the pressures were varied. In most of the combinations it was found that with constant slip the coefficient of friction diminished very slightly as the pressure of contact was increased, so that it may be considered practically constant for all pressures between 150 and 400 lbs. per sq. in.

The crushing strength of each material under the conditions of the test was determined by running each combination with increasing loads until a load was found under which the wheel failed before 15,000 revolutions had been made. The results showed the failure of the several fiber wheels under loads per inch of width as follows: Straw fiber 750 lbs.; leather fiber, 1,200 lbs.; tarred fiber, 1,200 lbs.; leather, 750 lbs.; sulphite fiber, 700 lbs. One-fifth of these pressures is taken as a safe working load. The coefficient of friction approaches its maximum value when the slip between driver and driven wheel is 2%. The safe working horse-power of the drive is calculated on the basis of 60% the coefficient developed at a pressure of 150 lbs. per inch of width, a reduction of 40% being made to cover possible decrease of the coefficient in actual service and to cover also loss due to friction of the journals. From these data the following table is constructed showing the H.P. that may be transmitted by driving wheels of the several materials named when in frictional contact with iron, aluminum and type metal.

$$\text{The formula for horse-power is } H.P. = \frac{\pi d}{12} \times \frac{WPN \times 0.6 f}{33000} = KdWN, \text{ in}$$

which *d* = diam. in inches, *W* = width of face in inches, *P* = safe working pressure in lbs. per in. of width, *N* = revs. per min., *f* = coefficient of friction, 0.6 a factor for the decrease of the coefficient in service and for the loss in journal friction, *K* a coefficient including *P*, *f* and the numerical constants.

COEFFICIENTS OF FRICTION AND HORSE-POWER OF FRICTION DRIVES.

	On Iron.		On Aluminum.		On Type Metal.	
	<i>f</i>	<i>k</i>	<i>f</i>	<i>k</i>	<i>f</i>	<i>k</i>
Straw fiber . . . . .	0.255	0.00030	0.273	0.00033	0.186	0.00022
Leather fiber . . . . .	0.309	0.00059	0.297	0.00057	0.183	0.00035
Tarred fiber . . . . .	0.150	0.00029	0.183	0.00035	0.165	0.00031
Sulphite fiber . . . . .	0.330	0.00037	0.318	0.00035	0.309	0.00034
Leather . . . . .	0.135	0.00016	0.216	0.00026	0.246	0.00029

Horse-power = *K* × *dWN*.

**Friction Clutches.** — Much valuable information on different forms of friction clutches is given in a paper by Henry Souther in *Trans. A. S. M. E.*, 1908, and in the discussion on the paper. All friction clutches contain two surfaces that rub on each other when the clutch is thrown into gear, and until the friction between them is increased, by the pressure with which they are forced together, to such an extent that the surfaces bind and enable one surface to drive the other. The surfaces may be metal on metal, metal on wood, cork, leather or other substance, leather on leather or other substance, etc. The surfaces may be disks, at right angles to the shaft, blocks sliding on the outer or inner surface, or both, of a pulley rim, or two cones, internal and external, one fitting in the other, or a band or ribbon around a pulley. The driving force which is just sufficient to cause one part of the clutch to drive the other is the product of the total pressure, exerted at right angles to the direction of sliding, and the coefficient of friction. The latter is an exceedingly variable quantity, depending on the nature and condition of the sliding surfaces and on their lubrication. The surfaces must have sufficient area so that the pressure per square inch on that area will not be sufficient to cause undue heating and wear. The total pressure on the parts of the mechanism that forces the surfaces together also must not cause undue wear of these parts.

For cone clutches, Reuleaux states that the angle of the cone should not be less than  $10^\circ$ , in order that the parts may not become wedged together. He gives the coefficient of cast iron on cast iron, for such clutches, at 0.15.

For clutches with maple blocks on cast iron Mr. Souther gives a coefficient of 0.37, and for a speed of 100 r.p.m. he gives the following table of capacity of such clutches, made by the Dodge Mfg. Co.

Horse-power.	Block Area, Ins.	Diam. at Block, Ins.	Circumferential Pull at Block Center, Lbs.	Total Pressure.	Total Pressure per Sq. In.
25	120	16	1,960	5,300	44
32	141	18	2,240	6,000	44.5
50	208	21.5	2,900	7,800	37.5
98	280	27.5	4,500	12,000	43.5

Prof. I. N. Hollis has found the coefficient of cork on cast iron to be from 0.33 to 0.37, or about double that of cast iron on cast iron or on bronze. A set of cork blocks outlasted a set of maple blocks in the ratio of five to one. Prof. C. M. Allen has found the torque for cork inserts to be nearly double that of a leather-faced clutch for a given dimension.

Disk clutches for automobiles are made with frictional surfaces of leather, bronze, or copper against iron or steel. The Cadillac Motor Car Co. give the following: Mean radius of leather frictional surface  $4\frac{5}{16}$  ins.; area of do.,  $36\frac{1}{2}$  sq. ins.; axial pressure, 1000 to 1200 lbs.; H.P. capacity at 400 r.p.m.,  $5\frac{1}{2}$  H.P.; at 1400 r.p.m., 10 H.P.

C. H. Schlesinger (*Horseless Age*, Oct. 2, 1907) gives the following formula for the ordinary cone clutch:

$$\text{H.P.} = PfrR \div 63,000 \sin. \theta,$$

in which  $P$  = assumed pressure of engaging spring in lbs.,  $f$  = coeff. of friction, which in ordinary practice is about 0.25;  $r$  = mean radius of the cone, ins.;  $R$  = r.p.m. of the motor;  $\theta$  = angle of the cone with the axis. Mr. Souther says the value of  $f = 0.25$  is probably near enough for a properly lubricated leather-iron clutch.

The Hele-Shaw clutch, with V-shaped rings struck up in the surfaces of disks, is described in *Proc. Inst. M. E.*, 1903. A clutch of this form 18 ins. diam. between the V's transmitted 1000 H.P. at 700 or 800 r.p.m.

**Coil Friction Clutches.** (H. L. Nachman, *Am. Mach.*, April 1, 1909.) — Friction clutches are now in use which will transmit 1000, and even more, horse-power. A type of clutch which is satisfactory for the transmission of large powers is the coil friction clutch. It consists of a steel coil wound on a chilled cast-iron drum. At each end of the coil a head is formed. The head at one end is attached to the pulley or shaft that is to be set in motion, while that at the other end of the coil serves as a point of application of a force which pulls on the coil to wind it on the drum, thus gripping it firmly.

The friction of the coil on the drum is the same as that of a rope or belt on a pulley. That is, the relation of the tensions at the two ends of the coil may be found from the equation  $P/Q = e^{\mu\alpha}$  where  $P$  = pull at fixed end of coil;  $Q$  = pull at free end of coil;  $e$  = base of natural logarithms = 2.718;  $\mu$  = coefficient of friction between coils and drum; and  $\alpha$  = Angle subtended by coil in radian measure, = 6.283 for each turn of coil.

Values of  $P/Q$  for different numbers of turns are as follows, assuming  $N = 0.05$  for steel on cast iron, lubricated:

No. of turns	1	2	3	4	5	6	7	8
$P/Q$ =	1.37	1.87	2.57	3.51	4.81	6.58	8.60	12.33

If  $D$  = diam. of drum in ins.,  $N$  = revs., per min., then  $\text{H.P.} = \pi DNP \div (12 \times 33,000) = 0.00000793 DNP$ .



HOISTING AND CONVEYING.

**Strength of Ropes and Chains.**—For the weight and strength of rope for hoisting see notes and tables on pages 410 to 416. For strength of chains see page 264.

**Working Strength of Blocks.**

(Boston and Lockport Block Co., 1908.)

REGULAR BLOCKS WITH LOOSE HOOKS—LOADS IN POUNDS

Size, Inches.	5	6	8	10	12	14
Rope diameter, inches....	9/16	3/4	7/8	1	1 1/8	1 1/4
2 single blocks.....	150	250	700	2000	4000	7000
2 double blocks.....	250	400	1200	4000	8000	12000
2 triple blocks.....	400	650	1900	6000	12000	19000

LOADS IN TONS.

Size, inches.....	WIDE MORTISE WITH LOOSE HOOKS.					EXTRA HEAVY WITH SHACKLES.			
	8	10	12	14	16	18	20	22	24
Rope, diam., in....	1	1 1/4	1 5/16	1 5/8	1 3/4	2	2 1/4	2 1/2	3
2 single blocks.....	1/2	2	4	6	10	.....	.....	.....	.....
2 double blocks....	1	3	6	8	12	25	30	35	40
2 triple blocks....	2	4	8	10	14	30	35	40	50
2 fourfold blocks..	.....	.....	.....	.....	.....	40	45	55	70

WORKING LOADS FOR A PAIR OF WIRE-ROPE BLOCKS—TONS

Sheave Diam., In.	LOOSE HOOKS.			SHACKLES.		
	Two Singles.	Two Doubles.	Two Triples.	Two Singles.	Two Doubles.	Two Triples.
8	3	4	5	4	5	6
10	4	5	6	6	8	10
12	5	6	7	8	10	12
14	6	7	8	10	12	15
16	7	8	10	12	15	20
18	8	10	12	15	20	25

**Chain Blocks.**—Referring to the table on the next page, the speed of a chain block is governed by the pull required on the hand chain and the distance the hand chain must travel to lift the load the required distance. The speeds are given for short lifts with men accustomed to the work; for continuous easy lifting two-thirds of these speeds are attainable. The triplex block lifts rapidly, and the speed increases for light loads because the length of hand chain to be overhauled is small. This fact also enables the operator to lower the load very quickly with the triplex block. The 12- to 20-ton triplex blocks are provided with two separate hand wheels, thus permitting two men to hoist simultaneously, thereby securing double speed. In the triplex block the power is transmitted to the hoisting-chain wheel by means of a train of spur gearing operated by the hand chain. In the duplex block the power is transmitted through a worm wheel and screw. In the differential block the power is applied by pulling on the slack part of the load chain and the force is multiplied by means of a differential sheave. (See page 539.) The relative efficiency and durability of the three types are as follows:

	Differential.	Duplex.	Triples.
Relative efficiency.....	35	50	100
Relative durability.....	20	80	100
Relative cost.....	40	80	100

**Chain Block Hoisting Speeds.**

(Yale & Towne Mfg. Co., 1908.)

Capacity in Tons.	Pull in Pounds required on Hand-Chain to Lift Full Loads.			Feet of Hand-Chain to be Pulled by Operator to Lift Load One Foot High.			Hoisting Speeds. Feet per Minute Attainable and No. of Men required for Hoisting Full Loads without Pulling over 80 Lb.							
	Triplex.	Duplex.	Differen-tial.	Triplex.	Duplex.	Differen-tial.	Triplex.				Duplex.		Differen-tial.	
							Full Load.	Half Load.	Quarter Load.	† No. of Men.	Full Load.	† No. of Men.	Full Load.	† No. of Men.
1/4	62	68	72	21	40	24	8.	16.	24.	1	4.	1	6.	1
1/2	82	87	216	31	59	30	4.	8.	12.	1	2.	1	3.70	3
1	110	94	246	35	80	36	4.8	9.6	14.4	2	2.40	2	2.50	3
1 1/2	120	115	308	42	93	42	3.6	7.2	10.8	2	1.80	2	2.30	4
2	114	132	557	69	126	38	2.3	4.6	6.9	2	1.10	2	2.30	7
3	124	142	.....	84	155	.....	1.7	3.5	5.2	2	0.80	2	.....	.....
4	110	145	.....	126	195	.....	1.3	2.6	3.9	2	0.65	2	.....	.....
5	130	145	.....	126	252	.....	1.1	2.2	3.3	2	0.50	2	.....	.....
6	135	160	.....	168	310	.....	0.8	1.6	2.4	2	0.35	2	.....	.....
8	140	160	.....	210	390	.....	0.6	1.2	1.8	2	0.30	2	.....	.....
10	130*	.....	.....	126*	.....	.....	1.1	2.2	3.3	4	.....	.....	.....	.....
12	135*	.....	.....	168*	.....	.....	0.8	1.6	2.4	4	.....	.....	.....	.....
16	140*	.....	.....	210*	.....	.....	0.6	1.2	1.8	4	.....	.....	.....	.....
20	.....	.....	.....	.....	.....	.....	.....	.....	.....	.....	.....	.....	.....	.....

\* On each of the two hand-chains.

† The number of men is based on each man pulling not over 80 lb. One man pulling 160 lb. or less, as given in the first two columns, can lift the full capacity of any Triplex or Duplex Block.

**Efficiency of Hoisting Tackle.** — (S. L. Wonsen, *Eng. News*, June 11, 1903.)

1 1/4 to 2-in. Manila rope.

Parts of line.	2	3	4	5	6	7	8	9	.....	.....
Ratio of load to pull.....	1.91	2.64	3.30	3.84	4.33	4.72	5.08	5.37	.....	.....
Efficiency, per cent.....	96	88	83	77	72	67	64	60	.....	.....

3/4-in. Wire rope.

Parts of line.	3	4	5	6	7	8	9	10	11	12	13
Ratio load to pull.....	2.73	3.47	4.11	4.70	5.20	5.68	6.08	6.46	6.78	7.08	7.34
Efficiency, per cent.....	91	87	82	78	74	71	68	65	62	59	56

**Proportions of Hooks.**—The following formulæ are given by Henry R. Towne, in his *Treatise on Cranes*, as a result of an extensive experimental and mathematical investigation. They apply to hooks of capacities from 250 lb. to 20,000 lb. Each size of hook is made from some commercial size of round iron. The basis in each case is, therefore, the size of iron of which the hook is to be made, indicated by *A* in the diagram. The dimension *D* is arbitrarily assumed. The other dimensions, as given by the formulæ, are those which, while preserving a proper bearing-face on the interior of the hook for the ropes or chains which may be passed through it, give the greatest resistance to spreading and to ultimate rupture, while the amount of material in the original bar admits of. The symbol  $\Delta$  is used to indicate the nominal capacity of the hook in tons of 2000 lb. The formulæ which determine the lines

of the other parts of the hooks of the several sizes are as follows, the measurements being all expressed in inches:

- $D = 0.5 \Delta + 1.25;$
- $E = 0.64 \Delta + 1.60;$
- $F = 0.33 \Delta + 0.85;$
- $G = 0.75 D;$
- $H = 1.08 A;$
- $I = 1.33 A;$
- $J = 1.20 A;$
- $K = 1.13 A;$
- $L = 1.05 A;$
- $M = 0.50 A;$
- $N = 0.85 B - 0.16;$
- $O = 0.363 \Delta + 0.66;$
- $Q = 0.64 \Delta + 1.60;$
- $U = 0.866 A.$

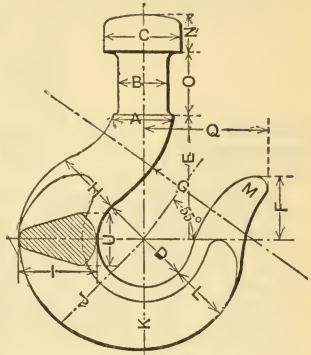

FIG. 189.

The dimensions A are necessarily based upon the ordinary merchant sizes of round iron. The sizes which it has been found best to select are the following:

Capacity of hook:		1 1/2	2	3	4	5	6	8	10 tons				
1/8	1/4	1/2	1	1 1/2	2	3	4	5	6	8	10 tons		
Dimension A:		5/8	11/16	3/4	1 1/16	1 1/4	1 3/8	1 3/4	2	2 1/4	2 1/2	2 7/8	3 1/4 in.

Experiment has shown that hooks made according to the above formulæ will give way first by opening of the jaw, which, however, will not occur except with a load much in excess of the nominal capacity of the hook. This yielding of the hook when overloaded becomes a source of safety, as it constitutes a signal of danger which cannot easily be overlooked, and which must proceed to a considerable length before rupture will occur and the load be dropped.

**Heavy Crane Hooks.**—A. E. Holcomb, vice-pres. of the Earth Moving Machinery Co., contributes the following (1908). Seven years ago, while engaged in the design of a 100-ton crane, I made a study of the variations in strength with the different sectional forms for hooks in most common use. As a result certain values which gave the best results were substituted in "Gordon's" formula and a formula was thereby obtained which was good for hooks of any size desired, provided the proper allowable fiber stress per square inch was made use of when designing. From this formula the enclosed table was made up and was published in the *American Machinist* of Oct. 31, 1901. Since that time hundreds of hooks of cast or hammered steel have been designed and made according to my formula, and not one of them, so far as I know, has ever failed.

The Industrial Works, Bay City, Michigan, manufacturers of heavy cranes, in December, 1904, made the following test under actual working conditions:

A hook was made of hammered steel having an elastic limit or yield point at approximately 36,000 lbs. per sq. in. fiber stress and having the following important dimensions:  $d = 75/8$  in.;  $r = 4 1/2$  in.;  $D = 207/16$  in.

When the applied load reached 150,000 lbs. the hook straightened out until the opening at the mouth of the hook was  $2 1/2$  in. larger than formerly, and the distance from center of action line of load to center of gravity of section was found to have decreased  $1/2$  in., at which point the hook held the load. Upon increasing the load still further, the hook opened still more. From the dimensions of the hook as originally formed, we find from the formula or table that the fiber stress with a load of 150,000 lbs. was 37,900 lbs. per sq. in., or in excess of the yield point, whereas making use of the dimensions obtained from the hook when it held we find that the fiber stress per square inch was reduced to 35,940 lbs., or under the yield point.

The designer must use his own judgment as to the selection of a proper allowable fiber stress, being governed therein by the nature of the material



to be used and the probability of the hook being overloaded at some time. Under average conditions I have made use of the following values for (*f*):

	Values of ( <i>f</i> ) in pounds for a load of —					
	1,000 to 5,000 lbs.	5,000 to 15,000 lbs.	15,000 to 30,000 lbs.	30,000 to 60,000 lbs.	60,000 to 100,000 lbs.	100,000 lbs. and up.
Cast iron.....	2,000	2,500	.....	.....	.....	.....
Steel casting.....	6,000	8,000	10,000	11,250	12,500	.....
Hammered steel.....	12,000	16,000	20,000	22,500	25,000	27,500

Mr. Holcomb's formula is given below, and his table in condensed form is given on page 1185.

DIRECTIONS. — *P* and *f* being known, assume *r* to suit the requirements for which the hook is to be designed. Divide *P* by *f* and find the quotient in the column headed by the required *r*. At the side of the Table, in the same row, will be found the necessary depth of section, *d*.

Notation. — *P* = load. *S* = area of section. *R*<sup>2</sup> = square of the radius of gyration. *f* = allowable fiber stress in lbs. per sq. in., 20,000 lbs. for hammered steel. For other letters see Fig. 190.

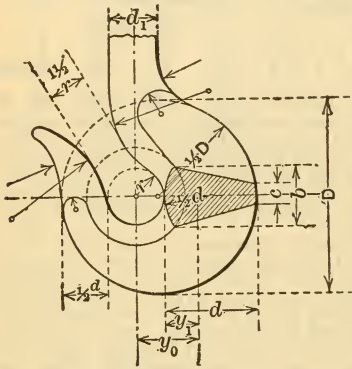

FIG. 190.

$$\frac{P}{f} = \frac{S}{1 + \frac{y_0 y_1}{R^2}} \text{ General formula.}$$

$$S = \frac{b + c}{2} \times d. \dots (1)$$

$$R^2 = \frac{d^2(b^2 + 4bc + c^2)}{18(b^2 + 2bc + c^2)}. \dots (2)$$

$$y_1 = \frac{b + 2c}{b + c} \times \frac{d}{3}. \dots (3)$$

$$y_0 = \left( \frac{b + 2c}{b + c} \times \frac{d}{3} \right) + r. \dots (4)$$

Assuming *b* = 0.66 *d*; *c* = 0.22 *d*, we have:

$$\frac{P}{f} = \frac{d^3}{7.44d + 12.393r} = K. (5)$$

$$d_1 = 0.5d.$$

$$D = 2r + 1.5d.$$

For values of *K* and *r* intermediate to those given in the table approximate values of *d* may be found by interpolation. Thus, for *K* = 3.700, *r* = 2.75.

Tabular values,	<i>r</i> = 2.5	3.0	Int. for 2.75
<i>d</i> = 6.50	<i>K</i> = 3.462	3.213	3.338
<i>d</i> = 7.00	<i>K</i> = 4.128	3.842	3.985

Whence:  $d = 6.5 + \left\{ \frac{(3.700 - 3.338)}{(3.985 - 3.338)} \right\} \times (7.0 - 6.5) = 6.78.$

In like manner, if *d* and *r* are given the value of *K* and the corresponding safe load may be found.

**Strength of Hooks and Shackles.** (Boston and Lockport Block Co., 1908.)—Tests made at the Watertown arsenal on the strength of hooks and shackles showed that they failed at the loads given in the table on page 1185. In service they should be subjected to only 50% of the figures in the table. Ordinarily the hook of a block gives way first, and where heavy weights are to be handled shackles are superior to hooks and should be used wherever possible.

**Horse-power Required to Raise a Load at a Given Speed.**—H.P. =  $\frac{\text{Gross weight in lb.}}{33,000} \times \text{speed in ft. per min.}$  To this add 25% to 50% for friction, contingencies, etc. The gross weight includes the weight of

Values of K.

d.	r.										
	0.50	0.75	1.00	1.50	2.00	2.50	3.00	3.50	4.00	5.00	6.00
2.00	0.379	0.331	0.292	0.240	0.203	0.176	0.155	.....	.....	.....	.....
2.25	.496	.437	.391	.329	.275	.239	.212	.....	.....	.....	.....
2.50	.629	.559	.504	.420	.360	.316	.281	.....	.....	.....	.....
2.75	.778	.697	.632	.532	.460	.404	.360	.....	.....	.....	.....
3.00	.944	.852	.776	.659	.572	.506	.454	0.411	.....	.....	.....
3.25	1.143	1.039	.953	.801	.700	.621	.559	.508	.....	.....	.....
3.50	1.342	1.226	1.129	.957	.841	.750	.677	.617	.....	.....	.....
3.75	1.558	1.429	1.321	1.148	.998	.893	.808	.738	.....	.....	.....
4.00	1.790	1.649	1.530	1.336	1.187	1.067	.953	.873	0.805	.....	.....
4.25	2.038	1.886	1.754	1.544	1.373	1.239	1.129	1.038	0.943	.....	.....
4.50	2.304	2.138	1.995	1.760	1.575	1.426	1.321	1.214	1.124	.....	.....
4.75	2.586	2.408	2.253	1.996	1.793	1.627	1.490	1.374	1.275	.....	.....
5.00	2.884	2.694	2.527	2.248	2.072	1.843	1.691	1.563	1.453	.....	.....
5.25	3.214	3.008	2.828	2.525	2.281	2.081	1.913	1.770	1.647	.....	.....
5.50	3.532	3.315	3.124	2.801	2.538	2.321	2.140	1.983	1.849	1.628	.....
5.75	.....	3.651	3.447	3.101	2.818	2.583	2.385	2.215	2.067	1.825	.....
6.00	.....	4.003	3.787	3.418	3.115	2.861	2.646	2.461	2.300	2.035	.....
6.50	.....	4.757	4.516	4.100	3.754	3.463	3.213	2.998	2.809	2.496	2.246
7.00	.....	5.578	5.311	4.848	4.459	4.128	3.842	3.594	3.377	3.012	2.719
7.50	.....	.....	6.173	5.661	5.227	4.855	4.533	4.252	4.003	3.584	3.244
8.00	.....	.....	7.102	6.540	6.061	5.648	5.287	4.970	4.689	4.213	3.825
8.50	.....	.....	8.096	7.485	6.960	6.504	6.104	5.750	5.436	4.900	4.460
9.00	.....	.....	9.158	8.496	7.924	7.424	6.984	6.593	6.243	5.645	5.152
9.50	.....	.....	.....	9.574	8.954	8.409	7.928	7.498	7.113	6.450	5.901
10.00	.....	.....	.....	10.788	10.220	9.460	8.932	8.467	8.044	7.316	6.708
10.50	.....	.....	.....	12.098	11.381	10.746	10.008	9.499	9.039	8.241	7.573
11.00	.....	.....	.....	13.374	12.608	11.922	11.316	10.766	10.267	9.228	8.498
11.50	.....	.....	.....	14.717	13.901	13.173	12.518	11.926	11.388	10.448	9.482
12.00	.....	.....	.....	16.126	15.261	14.485	13.785	13.150	12.572	11.558	10.697
12.50	.....	.....	.....	17.601	16.686	15.862	15.117	14.442	13.820	12.730	11.802
13.00	.....	.....	.....	.....	18.178	17.305	16.514	15.792	15.132	13.965	12.967
13.50	.....	.....	.....	.....	19.735	18.814	17.976	17.210	16.508	15.263	14.195
14.00	.....	.....	.....	.....	21.359	20.389	19.504	18.694	17.948	16.624	15.484
14.50	.....	.....	.....	.....	23.050	22.031	21.098	20.242	19.453	18.049	16.835
15.00	.....	.....	.....	.....	24.807	23.738	22.758	21.846	21.023	19.536	18.248
15.50	.....	.....	.....	.....	26.630	25.511	24.483	23.535	22.658	21.088	19.724
16.00	.....	.....	.....	.....	28.520	27.351	26.274	25.388	24.358	22.704	21.262

Strength of Hooks and Shackles.

HOOKS.*				SHACKLES.			
Size, Inches.	Tensile Strength, Pounds.	Tensile Strength, Pounds.	Description of Fracture.	Size, Inches.	Tensile Strength, Pounds.	Tensile Strength, Pounds.	Description of Fracture.
1/2	1,890	.....	.....	13/8	17,310	103,750	Eye of shackle.
9/16	2,560	.....	.....	11/2	20,940	119,800	Eye of shackle.
5/8	3,020	.....	.....	15/8	23,670	125,900	Eye of shackle.
3/4	4,470	20,700	Eye of shackle.	13/4	27,420	146,804	Sheared shackle pin.
7/8	6,280	38,100	Eye of shackle.	17/8	36,120	162,700	Eye of shackle.
1	12,600	51,900	Eye of shackle.	2	38,100	196,600	Shackle at neck of eye.
11/8	13,520	62,900	Sheared shackle pin.	21/2	55,380	210,400	Eye of shackle.
11/4	16,800	75,200	Eye of shackle.				

\* All the hooks failed by straightening the hook.

cage, rope, etc. In a shaft with two cages balancing each other use the net load + weight of one rope, instead of the gross weight.

To find the load which a given pair of engines will start. — Let  $A$  = area of cylinder in square inches, or total area of both cylinders, if there are two;  $P$  = mean effective pressure in cylinder in lb. per sq. in.;  $S$  = stroke of cylinder, inches;  $C$  = circumference of hoisting-drum, inches;  $L$  = load lifted by hoisting-rope, lb.;  $F$  = friction, expressed as a diminution of the load. Then  $L = \frac{A \times P \times 2S}{C} - F$ .

An example in *Coll'y Engr.*, July, 1891, is a pair of hoisting-engines 24"  $\times$  40", drum 12 ft. diam., average steam-pressure in cylinder = 59.5 lb.;  $A$  = 904.8;  $P$  = 59.5;  $S$  = 40;  $C$  = 452.4. Theoretical load, not allowing for friction,  $A \times P \times 2S \div C$  = 9589 lb. The actual load that could just be lifted on trial was 7988 lb., making friction loss  $F$  = 1601 lb., or 20 + per cent of the actual load lifted, or 16 $\frac{2}{3}$ % of the theoretical load.

The above rule takes no account of the resistance due to inertia of the load, but for all ordinary cases in which the acceleration of speed of the cage is moderate, it is covered by the allowance for friction, etc. The resistance due to inertia is equal to the force required to give the load the velocity acquired in a given time, or, as shown in Mechanics, equal to the product of the mass by the acceleration, or  $R = \frac{WV}{gT}$ , in which  $R$  = resistance in lb. due to inertia;  $W$  = weight of load in lb.;  $V$  = maximum velocity in ft. per second;  $T$  = time in seconds taken to acquire the velocity  $V$ ;  $g$  = 32.16.

**Safe Loads for Ropes and Chains.**—The table on p. 1187 was prepared by the National Founder's Association and published in *Indust. Eng.*, Sept., 1914. It shows the safe loads that can be carried by wire rope, crane chain and manila rope of the sizes given when used in the positions and combinations shown. The loads in the table are lower than those usually specified, in order to insure absolute safety. When handling molten metal, the ropes and chains should be 25 per cent stronger than the figures in the table.

**Effect of Slack Rope upon Strain in Hoisting.**—A series of tests with a dynamometer are published by the Trenton Iron Co., which show that a dangerous extra strain may be caused by a few inches of slack rope. In one case the cage and full tubs weighed 11,300 lb.: the strain when the load was lifted gently was 11,525 lb.; with 3 in. of slack chain it was 19,025 lb.; with 6 in. slack 25,750 lb., and with 9 in. slack 27,950 lb.

**Limit of Depth for Hoisting.**—Taking the weight of a cast-steel hoisting-rope of 1 $\frac{1}{8}$  in. diameter at 2 lb. per running foot, and its breaking strength at 84,000 lb., it should, theoretically, sustain itself until 42,000 feet long before breaking from its own weight. But taking the usual factor of safety of 7, then the safe working length of such a rope would be only 6000 ft. If a weight of 3 tons is now hung to the rope, which is equivalent to that of a cage of moderate capacity with its loaded cars, the maximum length at which such a rope could be used, with the factor of safety of 7, is 3000 ft., or

$$2x + 6000 = 84,000 \div 7; \therefore x = 3000 \text{ feet.}$$

This limit may be greatly increased by using special steel rope of higher strength, by using a smaller factor of safety, and by using taper ropes. (See paper by H. A. Wheeler, *Trans. A. I. M. E.*, xix. 107.)

**Large Hoisting Records.**—At a colliery in North Derbyshire during the first week in June, 1890, 6309 tons were raised from a depth of 509 yards, the time of winding being from 7 a.m. to 3.30 p.m.

At two other Derbyshire pits, 170 and 140 yards in depth, the speed of winding and changing has been brought to such perfection that tubs are drawn and changed three times in one minute. (*Proc. Inst. M. E.*, 1890.)



At the Nottingham Colliery near Wilkesbarre, Pa., in Oct., 1891, 70,152 tons were shipped in 24.15 days, the average hoist per day being 1318 mine cars. The depth of hoist was 470 ft., and all coal came from one opening. The engines were fast motion, 22  $\times$  48 in., conical drums 4 ft. 1 in. long, 7 ft. diameter at small end and 9 ft. at large end. (*Eng'g News*, Nov. 1891.)

**Large Engines.**—Two 34  $\times$  60 in. four-cylinder engines built by Nordberg Mfg. Co. for the Tamarack copper mine at Calumet, Mich., are



Safe Loads for Ropes and Chains.

NOTE. The safe loads in table are for each SINGLE rope or chain. When used double or in other multiples the loads may be increased proportionately.

		When Used Straight.	When Used at 60° Angle.	When Used at 45° Angle.	When Used at 30° Angle.	
						
		Lb.	Lb.	Lb.	Lb.	
PLOW STEEL WIRE ROPE.  [6 strands of 19 or 37 wires.]  If crucible steel rope is used reduce loads one-fifth.	Dia. In.					
	3/8	1,500	1,275	1,050	750	
	1/2	2,400	2,050	1,700	1,200	
	5/8	4,000	3,400	2,800	2,000	
	3/4	6,000	5,100	4,200	3,000	
	7/8	8,000	6,800	5,600	4,000	
	1	10,000	8,500	7,000	5,000	
	1 1/8	13,000	11,000	9,000	6,500	
	1 1/4	16,000	13,500	11,000	8,000	
	1 3/8	19,000	16,000	13,000	9,500	
1 1/2	22,000	19,000	16,000	11,000		
CRANE CHAIN.  [Best grade of wrought iron, hand- made, tested, short- link chain.]	Diam. of Iron, In.					
	1/4	600	500	425	300	
	3/8	1,200	1,025	850	600	
	1/2	2,400	2,050	1,700	1,200	
	5/8	4,000	3,400	2,800	2,000	
	3/4	5,500	4,700	3,900	2,750	
	7/8	7,500	6,400	5,200	3,700	
	1	9,500	8,000	6,600	4,700	
	1 1/8	12,000	10,200	8,400	6,000	
	1 1/4	15,000	12,750	10,500	7,500	
1 3/8	22,000	19,000	16,000	11,000		
MANILA ROPE.  [Best long fibre grade.]	Dia. In.	Cir. In.				
	3/8	1	120	100	85	60
	1/2	1 1/2	250	210	175	125
	5/8	2	360	300	250	180
	3/4	2 1/4	520	440	360	260
	7/8	2 3/4	620	520	420	300
	1	3	750	625	525	375
	1 1/8	3 1/2	1,000	850	700	500
	1 1/4	3 3/4	1,200	1,025	850	600
	1 1/2	4 1/2	1,600	1,350	1,100	800
	1 3/4	5 1/2	2,100	1,800	1,500	1,050
	2	6	2,800	2,400	2,000	1,400
	2 1/2	7 1/2	4,000	3,400	2,800	2,000
3	9	6,000	5,100	4,200	3,000	

designed to lift a load from a depth of 6,000 ft. at an average hoisting speed of 5,000 ft. per min. The load is made up of ore, 12,000 lbs.; cage and cars, 8,500 lbs.; 6,500 ft. of 1 1/2-in. rope, 21,200 lbs.; total, 41,700 lbs. The center lines of the cylinders are placed 90° apart and the cranks 135° apart. By this arrangement three of the four cylinders are always available for starting the hoist.

**Pneumatic Hoisting.** (H. A. Wheeler, *Trans. A. I. M. E.* xix, 107.)—A pneumatic hoist was installed in 1876 at Epinac, France, consisting of two continuous air-tight iron cylinders extending from the bottom to the top of the shaft. Within the cylinder moved a piston from which was hung the cage. It was operated by exhausting the air from above the piston, the lower side being open to the atmosphere. Its use was discontinued on account of the failure of the mine. Mr. Wheeler gives a description of the system, but criticizes it as not being equal on the whole to hoisting by steel ropes.

Pneumatic hoisting-cylinders using compressed air have been used at blast-furnaces, the weighted piston counterbalancing the weight of the

cage, and the two being connected by a wire rope passing over a pulley-sheave above the top of the cylinder. In the more modern furnaces steam-engine or electric hoists are generally used.

**Electric Mine-Hoists.**—An important paper on this subject, by D. B. Rushmore and K. A. Pauly, will be found in *Trans. A. I. M. E.*, 1910. See also *Electrical Hoisting*, page 1464.

**Counterbalancing of Winding-engines.** (H. W. Hughes, *Columbia Coll. Qly.*)—Engines running unbalanced are subject to enormous variations in the load; for let  $W$  = weight of cage and empty tubs, say 6270 lb.;  $c$  = weight of coal, say 4480 lb.;  $r$  = weight of hoisting rope, say 6000 lb.;  $r'$  = weight of counterbalance rope hanging down pit, say 6000 lb. The weight to be lifted will be:

	If weight of rope is unbalanced.	If weight of rope is balanced.		
At beginning of lift:	$W + c + r - W$ or 10,480 lb.	$W + c + r - (W + r')$ ,	}	
At middle of lift:	$W + c + \frac{r}{2} - (W + \frac{r}{2})$ or 4480 lb.	$W + c + \frac{r}{2} + \frac{r'}{2} - (W + \frac{r}{2} + \frac{r'}{2})$ ,		4480 lb.
At end of lift:	$W + c - (W + r)$ or minus 1520 lb.	$W + c + r' - (W + r)$ ,		

That counterbalancing materially affects the size of winding-engines is shown by a formula given by Mr. Robert Wilson, which is based on the fact that the greatest work a winding-engine has to do is to get a given mass into a certain velocity uniformly accelerated from rest, and to raise a load the distance passed over during the time this velocity is being obtained.

Let  $W$  = the weight to be set in motion: one cage, coal, number of empty tubs on cage, one winding rope from pit head-gear to bottom, and one rope from banking level to bottom.

- $v$  = greatest velocity attained, uniformly accelerated from rest;
- $g$  = gravity = 32.2;
- $t$  = time in seconds during which  $v$  is obtained;
- $L$  = unbalanced load on engine;
- $R$  = ratio of diameter of drum and crank circles;
- $P$  = average pressure of steam in cylinders;
- $N$  = number of cylinders;
- $S$  = space passed over by crank-pin during time  $t$ ;
- $C = \frac{2}{3}$ , constant to reduce angular space passed through by crank to the distance passed through by the piston during the time  $t$ ;
- $A$  = area of one cylinder, without margin for friction. To this an addition for friction, etc., of engine is to be made, varying from 10 to 30% of  $A$ .

1st. Where load is balanced.

$$A = \frac{\left\{ \left( \frac{Wv^2}{2g} \right) + \left( L \frac{vt}{2} \right) \right\} R}{PNSC}$$

2d. Where load is unbalanced:

The formula is the same, with the addition of another term to allow for the variation in the lengths of the ascending and descending ropes. In this case

- $h_1$  = reduced length of rope in  $t$  attached to ascending cage;
- $h_2$  = increased length of rope in  $t$  attached to descending cage;
- $w$  = weight of rope per foot in pounds. Then

$$A = \frac{\left[ \left( \frac{Wv^2}{2g} \right) + \left\{ \left( L \frac{vt}{2} \right) - \frac{h_1w + h_2w}{2} \right\} \right] R}{PNSC}$$

Applying the above formula when designing new engines, Mr. Wilson found that 30 in. diameter of cylinders would produce equal results, when balanced, to those of the 36-in. cylinder in use, the latter being unbalanced.

Counterbalancing may be employed in the following methods:

(a) *Tapering Rope.*—At the initial stage the tapering rope enables us to wind from greater depths than is possible with ropes of uniform section.

The thickness of such a rope at any point should only be such as to safely bear the load on it at that point.

With tapering ropes we obtain a smaller difference between the initial and final load, but the difference is still considerable, and for perfect equalization of the load we must rely on some other resource. The theory of taper ropes is to obtain a rope of uniform strength, thinner at the cage end where the weight is least, and thicker at the drum end where it is greatest.

(b) *The Counterpoise System* consists of a heavy chain working up and down a staple pit, the motion being obtained by means of a special small drum placed on the same axis as the winding drum. It is so arranged that the chain hangs in full length down the staple pit at the commencement of the winding; in the center of the run the whole of the chain rests on the bottom of the pit, and, finally, at the end of the winding the counterpoise has been rewound upon the small drum, and is in the same condition as it was at the commencement.

(c) *Loaded-wagon System.* — A plan, formerly much employed, was to have a loaded wagon running on a short incline in place of this heavy chain; the rope actuating this wagon being connected in the same manner as the above to a subsidiary drum. The incline was constructed steep at the commencement, the inclination gradually decreasing to nothing. At the beginning of a wind the wagon was at the top of the incline, and during a portion of the run gradually passed down it till, at the meet of cages, no pull was exerted on the engine — the wagon by this time being at the bottom. In the latter part of the wind the resistance was all against the engine, owing to its having to pull the wagon up the incline, and this resistance increased from nothing at the meet of cages to its greatest quantity at the conclusion of the lift.

(d) *The Endless-rope System* is preferable to all others, if there is sufficient sump room and the shaft is free from tubes, cross timbers, and other impediments. It consists in placing beneath the cages a tail rope, similar in diameter to the winding rope, and, after conveying this down the pit, it is attached beneath the other cage.

(e) *Flat Ropes Coiling on Reels.* — This means of winding allows of a certain equalization, for the radius of the coil of ascending rope continues to increase, while that of the descending one continues to diminish. Consequently, as the resistance decreases in the ascending load the leverage increases, and as the power increases in the other, the leverage diminishes. The variation in the leverage is a constant quantity, and is equal to the thickness of the rope where it is wound on the drum.

By the above means a remarkable uniformity in the load may be obtained, the only objection being the use of flat ropes, which weigh heavier and only last about two-thirds the time of round ones.

(f) *Conical Drums.* — Results analogous to the preceding may be obtained by using round ropes coiling on conical drums, which may either be smooth, with the successive coils lying side by side, or they may be provided with a spiral groove. The objection to these forms is, that perfect equalization is not obtained with the conical drums unless the sides are very steep, and consequently there is great risk of the rope slipping; to obviate this, scroll drums were proposed. They are, however, expensive, and the lateral displacement of the winding rope from the center line of pulley becomes very great, owing to their necessary large width.

(g) *The Koepe System of Winding.* — An iron pulley with a single circular groove takes the place of the ordinary drum. The winding rope passes from one cage, over its head-gear pulley, round the drum, and, after passing over the other head-gear pulley, is connected with the second cage. The winding rope thus encircles about half the periphery of the drum in the same manner as a driving-belt on an ordinary pulley. There is a balance rope beneath the cages, passing round a pulley in the sump; the arrangement is like an endless rope, with the cages as points of attachment.

## CRANES.

**Classification of Cranes.** (Henry R. Towne, *Trans. A. S. M. E.* iv., 288. Revised in *Hoisting*, published by The Yale & Towne Mfg. Co.)

A Hoist is a machine for raising and lowering weights. A Crane is a hoist with the added capacity of moving the load in a horizontal or lateral direction.



Cranes are divided into two classes, as to their motions, viz. *Rotary* and *Rectilinear*, and into four groups, as to their source of motive power, viz.:

*Hand.* — When operated by manual power.

*Power.* — When driven by power derived from line shafting.

*Steam, Electric, Hydraulic, or Pneumatic.* — When driven by an engine or motor attached to the crane, and operated by steam, electricity, water, or air transmitted to the crane from a fixed source of supply.

*Locomotive.* — When the crane is provided with its own boiler or other generator of power, and is self-propelling; usually being capable of both rotary and rectilinear motions.

Rotary and Rectilinear Cranes are thus subdivided.

#### ROTARY CRANES.

(1) *Swing-cranes.* — Having rotation, but no trolley motion.

(2) *Jib-cranes.* — Having rotation, and a trolley traveling on the jib.

(3) *Column-cranes.* — Identical with the jib-cranes, but rotating around a fixed column (which usually supports a floor above).

(4) *Pillar-cranes.* — Having rotation only; the pillar or column being supported entirely from the foundation.

(5) *Pillar Jib-cranes.* — Identical with the last, except in having a jib and trolley motion.

(6) *Derrick-cranes.* — Identical with jib-cranes, except that the head of the mast is held in position by guy-rods, instead of by attachment to a roof or ceiling.

(7) *Walking-cranes.* — Consisting of a pillar or jib-crane mounted on wheels and arranged to travel longitudinally upon one or more rails.

(8) *Locomotive-cranes.* — Consisting of a pillar-crane mounted on a truck, and provided with a steam-engine capable of propelling and rotating the crane, and of hoisting and lowering the load.

#### RECTILINEAR CRANES.

(9) *Bridge-cranes.* — Having a fixed bridge spanning an opening, and a trolley moving across the bridge.

(10) *Tram-cranes.* — Consisting of a truck, or short bridge, traveling longitudinally on overhead rails, and without trolley motion.

(11) *Traveling-cranes.* — Consisting of a bridge moving longitudinally on overhead tracks, and a trolley moving transversely on the bridge.

(12) *Gantries.* — Consisting of an overhead bridge, carried at each end by a trestle traveling on longitudinal tracks on the ground, and having a trolley moving transversely on the bridge.

(13) *Rotary Bridge-cranes.* — Combining rotary and rectilinear movements and consisting of a bridge pivoted at one end to a central pier or post, and supported at the other end on a circular track; provided with a trolley moving transversely on the bridge.

For descriptions of these several forms of cranes see Towne's "Treatise on Cranes."

**Stresses in Cranes.** — See Stresses in Framed Structures, p. 541, *ante*.

**Position of the Inclined Brace in a Jib-crane.** — The most economical arrangement is that in which the inclined brace intersects the jib at a distance from the mast equal to four-fifths the effective radius of the crane. (*Hoisting.*)

**Electric Overhead Traveling Cranes.** (From data supplied by Alliance Machine Co., Alliance, O., and Pawling & Harnischfeger, Milwaukee.) — Electric overhead traveling cranes usually have 3 motors, for hoisting, traversing the hoist trolley on the bridge and for moving the bridge, respectively. The usual range of motor sizes is as follows: Hoist, 15-50 H.P.; trolley, 3-15 H.P.; bridge, 15-50 H.P. The speeds at which the various motions are made range as follows, the figures being feet per minute: Hoist, 8-60; trolley traverse, 75-200; bridge travel, 200-600. These speeds are varied in the same capacity of crane to suit each particular installation. In general, the speed of the bridge in feet per minute should not exceed (length of runway + 100). If the runway is long and covered by more than one crane, the speed may be made equal to the average distance between cranes + 100. Usually 300 ft. per min. is a good speed. For small cranes in special cases, the speeds may be increased, but for cranes of over 50 tons capacity the speed should be below 300 ft. per min. unless the building is made especially strong to stand the strains incident to starting and stopping heavy cranes geared for high speeds.

**Cranes of over 15 tons capacity usually have an auxiliary hoist of  $\frac{1}{5}$  the capacity of the main hoist, and usually operated by the same motor.** Wire rope is now almost exclusively used for hoisting with cranes. The diameter of the drums and sheaves should be not less than 30 times the diameter of the hoisting rope, and should have a factor of safety of 5. Cranes are equipped with automatic load brakes to sustain the load when lifted and to regulate the speed when lowering, it being necessary for the hoist to drive the load down.

The voltage now standard for crane service is 220 volts at the crane motor, although 110 volts for small cranes is not objectionable. Voltages of 500-600 are inadvisable, especially in foundries and steel works, where dust and metallic oxides cover many parts of the crane and necessitate frequent cleaning to avoid grounds. On account of the danger from the higher voltages, the operators are apt to neglect this part of their work.

**Power Required to Drive Cranes.** (Morgan Engineering Co., Alliance, O., 1909.) — The power required to drive the different parts of cranes is determined by allowing a certain friction percentage over the power required to move the dead load. On hoist motions  $33\frac{1}{3}\%$  is allowed for friction of the moving parts, thus giving a motor of  $\frac{1}{3}$  greater capacity than if friction were neglected. For bridge and trolley motions, a journal friction of the track wheel axles of 10% of the total weight of the crane and load is allowed. There is then added an allowance of  $33\frac{1}{3}\%$  of the horse-power required to drive the crane and load plus the track wheel axle friction, to cover friction of the gearing. In selecting motors, the most important consideration is the maximum starting torque which the motor can exert. With alternating-current motors, this is less than with direct-current motors, requiring a larger motor, particularly on the bridge and trolley motions which require the greatest starting torque.

Walter G. Stephan says (*Iron Trade Rev.*, Jan. 7, 1909) that the bridge girders should be made of two plates latticed, or box girders, their depth varying from  $\frac{1}{10}$  to  $\frac{1}{20}$  of the span. The important feature of crane girder design is ample strength and stiffness, both vertically and laterally. Especial attention should be given to the transverse strain on the bridge due to sudden stopping or starting of heavy loads. The wheel base on the end trucks should have a ratio to the crane span of 1 to 6, although for long spans this ratio must necessarily be reduced to 1 to 8. Quick-traveling cranes should have as long a wheel base as possible, since the tendency to twist increases with the speed. Where several wheels are necessary at each end to support the crane, equalizing means should be used.

A recent development in cranes is the four- or six-girder crane for handling ladles of molten metal in steel works. The main trolley runs on the outer girders, with the hoist ropes depending between the outer and inner girders. The auxiliary trolley runs on the inner girders, thus being able to pass between the main ropes, and tilt the ladle in either direction.

**Dimensions and Wheel Loads of Electric Traveling Cranes.**

Based on 60-ft. span and 25-ft. lift; wire rope hoist.

(Alliance Machine Co., 1908.)

Capacity, Tons (2000 Lb.).	Distance Run- way Rail to Highest Point.		Distance Center of Rail to Ends of Crane.	Wheel Base of End Truck.		Maximum Load per Wheel; Trol- ley at End of Bridge.
	Ft.	In.	In.	Ft.	In.	Pounds.
5	6	0	9	9	0	20,000
10	6	6	10	10	0	27,000
25	7	4	12	11	6	51,000
40	8	0	12	12	3	82,000
50	8	9	12	12	6	48,000*

\* Has 8 track wheels on bridge.

Standard cranes are built in intermediate sizes, varying by 5 tons, up to 40 tons.

## Standard Hoisting and Traveling Speeds of Electric Cranes.

(Pawling &amp; Harnischfeger, 1908.)

Capacity, Tons (2000 Lb.).	Hoisting Speed, Ft. per Min.	Bridge Travel Speed, Ft. per Min.	Capacity Aux. Hoist, Tons.	Speed Aux. Hoist, Ft. per Min.
5	25-100	300-450	.....	.....
10	20-75	300-450	3	30-75
25	10-40	250-350	3	50-125
40	9-30	250-350	10	25-60
50	8-30	200-300	5	40-100
75	6-25	200-250	10	25-60
125	5-15	200-250	5	40-100
150	5-15	200-250	10	25-60
			15	20-50
			25	20-50
			25	20-50

Trolley\* travel speed from 100-150 ft. per min. in all cases.

## Notable Crane Installations. (1909.)

Capacity, Tons.	Span.	No. of Trolleys.	Capacity of Auxiliary Hoist, Tons.	H.P. of Hoist Motor.		H.P. of Trolley Motor.	H.P. of Bridge Motor.	Hoisting Speed, Ft. per Min.	Bridge Speed, Ft. per Min.	Trolley Travel Speed, Ft. per Min.	Depth of Main Girders.	Where Installed.	Maker.
				Main.	Auxiliary.								
150	65 0	1	25	75†	{35 10}	30	75	8-24	150-200	100-150	7 0	4	1
150	55 0	1	30	120	50	35	50	8	150-200	75-100	.....	5	3
150	65 0	2	15	75†	30†	18†	75	10-25	150-200	100-150	7 6	4	1
125*	.....	2	.....	110	{50 30}	{30 15}	100†	10	200	{80 125}	5 10	6	2
120	56 7	2	10	50†	18	10†	52†	10-25	150-300	100-150	5 5	7	1
100	65 0	2	10	50†	18	10†	50	10-25	200-250	100-150	5 5	8	1
80	74 0	2	10	40†	18†	10†	40	10-25	200-250	100-150	5 10 1/2	9	1
50	129 11 1/4	1	15	50	25	7 1/2	50	10	100-150	80-100	8 6	10	3
50	125 10	1	15	50	25	7 1/2	50	10	100-150	80-100	8 6	11	3
50	121 2	1	5	75	15	15	75	11 1/2	225	125	8 4	12	2

\* Four-girder ladle crane. † On each trolley.

‡ Divided equally between 2 motors for series-parallel control.

1. Pawling & Harnischfeger; 2. Alliance Mach. Co.; 3. Morgan Engineering Co.; 4. Midvale Steel Co., Phila.; 5. Homestead Steel Works, Munhall, Pa.; 6. Indiana Steel Co., Gary, Ind.; 7. Oregon Ry. & Nav. Co., Portland, Ore.; 8. El Paso & S. W. Ry., El Paso, Tex.; 9. C. & E. I. Ry., Danville, Ill.; 10. 3d Ave. Ry., N. Y. City; 11. United Rys. Co., Baltimore; 12. Carnegie Steel Co., Youngstown, Ohio.

**A 150-ton Pillar-crane** was erected in 1893 on Finnieston Quay, Glasgow. The jib is formed of two steel tubes, each 39 in. diam. and 90 ft. long. The radius of sweep for heavy lifts is 65 ft. The jib and its load are counterbalanced by a balance-box weighted with 100 tons of iron and steel punchings. In a test a 130-ton load was lifted at the rate of 4 ft. per minute, and a complete revolution made with this load in 5 minutes. *Eng'g News*, July 20, 1893.

**Compressed-air Traveling-cranes.**—Compressed-air overhead traveling-cranes have been built by the Lane & Bodley Co., of Cincinnati. They are of 20 tons nominal capacity, each about 50 ft. span and 400 ft. length of travel, and are of the triple-motor type, a pair of simple reversing-engines being used for each of the necessary operations, the pair of engines for the bridge and the pair for the trolley travel being each 5-inch bore by 7-inch stroke, while the pair for hoisting is 7-inch bore by 9-inch stroke.



The air-pressure when required is somewhat over 100 pounds. The air-compressor is allowed to run continuously without a governor, the speed being regulated by the resistance of the air in a receiver. An auxiliary receiver is placed on each traveler, whose object is to provide a supply of air near the engines for immediate demands and independent of the hose connection. Some of the advantages said to be possessed by this type of crane are: simplicity; absence of all moving parts, excepting those required for a particular motion when that motion is in use; no danger from fire, leakage, electric shocks, or freezing; ease of repair; variable speeds and reversal without gearing; almost entire absence of noise; and moderate cost.

**Quay-cranes.** — An illustrated description of several varieties of stationary and traveling cranes, with results of experiments, is given in a paper on Quay-cranes in the Port of Hamburg by Chas. Nehls, *Trans. A. S. C. E.*, 1893.

**Hydraulic Cranes, Accumulators, etc.** — See Hydraulic Pressure Transmission, page 812, *ante*.

**Electric versus Hydraulic Cranes for Docks.** — A paper by V. L. Raven, in *Trans. A. S. M. E.*, 1904, describes some tests of capacity and efficiency of electric and hydraulic power plants for dock purposes at Middlesbrough, Eng. In loading two cargoes of rails, weighing respectively 1210 and 1225 tons, the first was done with a hydraulic crane, in 7 hours, with 3584 lbs. of coal burned in the power station, and the second with an electric crane in 5¼ hours, with 2912 lbs. of coal. The total cost including labor, per 100 tons, was 327 pence with the hydraulic and 245 pence for the electric crane, a saving by the latter of 25 %.

**Loading and Unloading and Storage Machinery** for coal, ore, etc., is described by G. E. Titcomb in *Trans. A. S. M. E.*, 1908. The paper illustrates automatic ore unloaders for unloading ore from the hold of a vessel and loading it onto cars, and car-dumping machinery, by which a 50-ton car of coal is lifted, turned over and its contents discharged through a chute into a vessel. Methods of storage of coal and of re-loading it on cars are also described.

**Power Required for Traveling-Cranes and Hoists.** — Ulrich Peters, in *Machy*, Nov. 1907, develops a series of formulæ for the power required to hoist and to move trolleys on cranes. The following is a brief abstract. Resistance to be overcome in moving a trolley or crane-bridge.  $P_1$  = rolling friction of trolley wheels,  $P_2$  = journal friction of wheels or axles,  $P_3$  = inertia of trolley and load.  $P$  = sum of these resistances =  $P_1 + P_2 + P_3 = (T + L) \left( \frac{f_1 + f_2 d}{D} + \frac{v}{1932t} \right)$  in which  $T$  = weight of trolley,  $L$  = load,  $f_1$  = coeff. of rolling friction, about 0.002, (0.001 to 0.003 for cast iron on steel);  $f_2$  = coeff. of journal friction, = 0.1 for starting and 0.01 for running, assuming a load on brasses of 1000 to 3000 lb. per sq. in.; [ $f_2$  is more apt to be 0.05 unless the lubrication is perfect. See Friction and Lubrication, W. K.]  $d$  = diam. of journal;  $D$  = diam. of wheels;  $v$  = trolley speed in ft. per min.;  $t$  = time in seconds in which the trolley under full load is required to come to the maximum speed. Horse-power = sum of the resistances  $\times$  speed, ft. per min.  $\div$  33,000.

Force required for hoisting and lowering:  $F_h$  = actual hoisting force,  $F_0$  = theoretical force or pull,  $L$  = load,  $v$  = speed in ft. per min. of the rope or chain,  $c$  = hoisting speed of the load  $L$ ,  $c/v$  = transmission ratio of the hoist,  $e$  = efficiency =  $F_0/F_h$ . The actual work to raise the load per minute =  $F_h v = Lc = F_0 v \div e$ . The efficiency  $e$  is the product of the efficiencies of all the several parts of the hoisting mechanism, such as sheaves, windlass, gearing, etc. Methods of calculating these efficiencies, with examples, are given at length in the original paper by Mr. Peters.

**Lifting Magnets.** — (From data furnished by the Electric Controller and Mfg. Co., Cleveland, and the Cutler-Hammer Clutch Co., Milwaukee). Lifting magnets first came into use about 1898. They have had wide application for handling pig iron, scrap, castings, etc. A lifting magnet comprises essentially a magnet winding, a pole-piece, a shoe and a protecting case, which is ribbed to afford ample radiating surface to dissipate the heat generated in operation. The winding usually consists of coils, each wound with copper ribbon and insulated with asbestos. The insulation must be designed to withstand a higher voltage than the line

voltage, due to the inductive kick when the circuit is opened. The wearing plate, which takes the shocks incident to picking up the load, is usually made of manganese steel. The shape of the pole piece or lifting surface of the magnet must be varied, as the same shape is not usually applicable to all classes of materials. For handling pig iron, scrap, etc., a concave pole surface is usually superior to a flat one, which is adapted to handling plates or flat material of similar character, and which bear equally on the piece to be lifted at both the edge and center. A test of a lifting magnet made at the works of the Youngstown Sheet and Tube Co., in 1907, showed the following results:

Total pig iron unloaded, 109,350 pounds; weight of average lift, 785 pounds; time required, 2 hours, 15 minutes; current on magnet, 1 hour 15 minutes; current required, 30 amperes.

The No. 3 and No. 4 magnets are particularly fitted for use on steam-driven locomotive cranes, and when so used are usually supplied with current from a small steam-driven generator set mounted on the crane, steam being drawn from the boiler of the crane. Nos. 5 and 6 are adapted for use with overhead electric traveling cranes in cases where large lifts and high speed of handling are essential.

SIZES AND CAPACITIES OF THE ELECTRIC CONTROLLER & MFG. CO.'S  
TYPE S-A LIFTING MAGNETS (1909).

Size.	Diam.	Weight.	Average Current at 220 Volts.	Lifts in Machine Cast Pig Iron.	
				Maximum Lift.	Average Lift.
	In.	Lb.	Amp.	Lb.	Lb.
3	36	2,100	11	1,405	750
4	43	3,200	27	2,180	1,250
5	52	4,800	35	3,087	1,800
6	61	6,600	45	4,589	2,600

SIZES AND CAPACITIES OF LIFTING MAGNETS (CUTLER-HAMMER), 1908.

Size, In.	Weight Lb.	Maximum* Lifting Capacity, Lb.	Average Lifting Capacity, Lb.	Current Required at 220 Volts, Amperes.	Head-room Required, Ft.
10	75	800	100-300	1	.....
35	1,650	5,000	500-1,000	15-18	4
50	5,000	20,000	1,000-2,000	30-35	6

\* This capacity can be obtained only under the most favorable conditions, with complete magnetic contact between the magnet and the piece to be lifted.

The capacity of a lifting magnet in service depends on many other factors than the design of the magnet. Most important is the character of the material handled. Much more can be handled at a single lift with material like billets, ingots, etc., than with scrap, wire, pig iron, etc. The speed of the crane, from which the magnet is suspended, and the distance it must transport the material are also important factors to be considered in calculating the capacity of a given magnet under given conditions. The following results have been selected from a great number of tests of the Electric Controller and Mfg. Co.'s No. 2 Type S magnets in commercial service, and represent what is probably average practice. It should be borne in mind that the average lift is determined from a large number of lifts, including lifts made from a full car of, say, pig iron, where the magnetic conditions are very favorable, and also the "lean" lifts where the car is nearly empty, and magnetic conditions unfavorable; the magnet can reach only a few pigs at one time on the lean lifts, with a consequent heavy decrease in the size of the load. The average lift is therefore less than the maximum lift in handling a given lot of material.

\* When operated from an ordinary electric overhead traveling crane a magnet of the type used in these trials will handle from 20 to 30 tons per hour of the scrap used by open-hearth furnaces. If operated from a special fast crane, the amount may be somewhat increased. Average lifts in pounds for various materials are as follows:

Skull cracker balls up to 20,000; ingot (or if ground man places magnet, two), each, 6,000; billet slabs, 900-6,000.

The above weights depend on dimensions and whether in pile or stacked evenly.

Machine cast pig iron, 1,250; sand cast pig iron, 1,150.

These are values obtained in unloading railway cars, including lean lifts in cleaning up.

Machine cast pig iron, 1,350; sand cast pig iron, 1,200.

The above are average lifts from stockpile.

Heavy melting stock (billets, crop ends of billets, rails or structural shapes, 1,250; boiler plate scrap, 1,100; farmers' scrap (harvesting machinery parts, plow points, etc.), 900; small risers from steel castings, 1,600; fine wire scrap, scrap tubing not over 3 ft. long, loose even or lamination scrap, 500; bundled scrap, 1,200; miscellaneous junk dealers' scrap, 400-800.

COMMERCIAL RESULTS WITH A 52-INCH, 5,000 POUND MAGNET.  
(Electric Controller & Mfg. Co., 1908.)

Hoist speed, ft. per min.	Crane.		Distance moved.			Total Weight Moved, Tons.	No. of Lifts.	Aver. weight per lift, lbs.	Total time, Minutes.	Conditions of Working.
	Trolley speed, ft. per min.	Bridge speed, ft. per min.	Hoist, Ft.	Trolley, Ft.	Bridge, Ft.					
60	80	315	5	6	3	60	73	1,650	75	1*
60	80	315	3	6	6	35	55	1,275	60	2
60	80	315	10	36	15	39.3	60	1,328	60	3
60	80	315	10	20	40	33.9	55	1,234	55	4
50	200	550	3	6	3	78.	132	1,182	135	5
50	200	550	4	7	8	78	168	929	190	6
50	200	550	5	8	0	26	30	173	45	7
50	200	550	4	6	3	80	300	534	300	8
240	171	160	12	30	12	25	25	2,000	80	9
240	171	160	15	10	150	112	56	4,000	120	10
240	171	160	7	12	5	7	8	1,740	15	11
240	171	160	5	13	0	5	4	2,660	10	12

\* 1. Machine cast pig handled from stock pile to charging boxes. 2. Bull heads, ditto. 3. Sand cast pig unloaded from car to stock pile. 4. Baled tin and wire unloaded from car to stock pile. 5. Boiler plate scrap handled from stock pile to charging boxes. 6. Farmers' scrap, comprising knotters and butters from threshing and binding machines, sections of cutter bars from mowers, broken steel teeth from hay rakes, plow points, etc., from stock pile to charging boxes. 7. Small risers from steel castings, handled from stock pile to charging boxes. 8. Laminated plates from armatures and transformers, mixed sizes, from stock pile to charging boxes. 9. Cast iron sewer pipe, 3 feet diameter, weighing 2,000 pounds each, lifted from cars to flat boat. Each pipe had to be blocked and lashed to prevent washing overboard. 10. Pennsylvania Railroad East-River tunnel section castings, convex on one side, concave on other, weighing 4,000 pounds each. Handled from local float to barge for shipment. 11. Steel plate 1/2-inch X 10 inches X 6 feet 0 inches handled from car to float. 12. Steel rails, 40 pounds per yard, 25 feet long. Handled from car to lighter, about 8 rails per lift.

The above results of tests relate to the Electric Controller & Mfg. Co.'s No. 2 Type "S" magnet, 52 in. diameter and weighing 5200 lbs. and are the average of a large number of tests made at various plants between the years 1905 and 1908. This type of magnet is being superseded by the No. 4 Type S-A magnet which is 43 in. diameter, weighs 3200 lbs. and gives substantially the same average lift.



### TELPHERAGE.

Telpherage is a name given to a system of transporting materials in which the load is suspended from a trolley or small truck running on a cable or overhead rail, and in which the propelling force is obtained from an electric motor carried on the trolley. The trolley, with its motor, is called a "telpher." A historical and illustrated description of the system is given in a paper by C. M. Clark, in *Trans. A. I. E. E.*, 1902. A series of circulars of the Link Belt Co., Philadelphia, show numerous illustrations of the system in operation for handling different classes of materials. Telpherage is especially applicable for moving packages in warehouses, on wharfs, etc. The moving machinery consists of the telpher or the conveying power, with accompanying trailers; the portable electric hoist or the vertical elevating power, and the carriers containing the load. Among the accessories are brakes, switches and controlling devices of many kinds.

An automatic line is controlled by terminal and intermediate switches which are operated by the men who do the loading and unloading, no additional labor being required. A non-automatic line necessitates a boy to accompany the telpher. The advisability of using the non-automatic rather than the automatic line is usually determined by the distance between stations.

### COAL-HANDLING MACHINERY.

The following notes and tables are supplied by the Link-Belt Co.

In large boiler-houses coal is usually delivered from hopper-cars into a track-hopper, about 10 feet wide and 12 to 16 feet long. A feeder set under the track-hopper feeds the coal at a regular rate to a crusher, which reduces it to a size suitable for stokers.

After crushing, the coal is elevated or conveyed to overhead storage-bins. Overhead storage is preferred for several reasons:

1. To avoid expensive wheeling of coal in case of a breakdown of the coal-handling machinery.
2. To avoid running the coal-handling machinery continuously.
3. Coal kept under cover indoors will not freeze in winter and clog the supply-spouts to the boilers.
4. It is often cheaper to store overhead than to use valuable ground-space adjacent to the boiler-house.
5. As distinguished from vault or outside hopper storage, it is cheaper to build steel bins and supports than masonry pits.

**Weight of Overhead Bins.** — Steel bins of approximately rectangular cross-section, say 10 × 10 feet, will weigh, exclusive of supports, about one-sixth as much as the contained coal. Larger bins, with sloping bottoms, may weigh one-eighth as much as the contained coal. Bag bottom bins of the Berquist type will weigh about one-twelfth as much as the contained coal, not including posts, and about one-ninth as much, including posts.

**Supply-pipes from Bins.** — The supply-pipes from overhead bins to the boiler-room floor, or to the stoker-hoppers, should not be less than 12 inches in diameter. They should be fitted at the top with a flanged casting and a cut-off gate, to permit removal of the pipe when the boilers are to be cleaned or repaired.

**Types of Coal Elevators.** — Coal elevators consist of buckets of various shapes attached to one or more strands of link-beltting or chain, or to rubber belting. The buckets may either be attached continuously or at intervals. The various types are as follows:

*Continuous bucket elevators* consist usually of one strand of chain and two sprocket-wheels with buckets attached continuously to the chain. Each bucket after passing the head wheel acts as a chute to direct the flow from the next bucket. This type of elevator will handle the larger sizes of coal. It runs at slow speeds, usually from 90 to 175 feet per minute, and has a maximum capacity of about 120 tons per hour.

*Centrifugal discharge elevators* consist usually of a single strand of chain, with the buckets attached thereto at intervals. They are used to handle the smaller sizes of coal in small quantities. They run at high speeds, usually 34 to 40 revolutions of the head wheel per minute, and have a capacity up to 40 tons per hour.

*Perfect discharge elevators* consist of two strands of chain, with buckets at intervals between them. A pair of idlers set under the head wheels cause the buckets to be completely inverted, and to make a clean delivery into the chutes at the elevator head. This type of elevator is useful in handling material which tends to cling to the buckets. It runs at slow speeds, usually less than 150 feet per minute. The capacity depends on the size of the buckets.

**Combined Elevators and Conveyors** are of the following types:

*Gravity discharge elevators*, consisting of two strands of chain, with spaced V-shaped buckets fastened between them. After passing the head wheels the buckets act as conveyor-flights and convey the coal in a trough to any desired point. This is the cheapest type of combined elevator and conveyor, and is economical of power. A machine carrying 100 tons of coal per hour, in buckets 20 inches wide, 10 inches deep, and 24 inches long, spaced 3 feet apart, requires 5 H.P. when loaded and 1 1/2 H.P. when empty for each 100 feet of horizontal run, and 1/9 H.P. for each foot of vertical lift.

*Rigid bucket-carriers* consist of two strands of chain with a special bucket rigidly fastened between them. The buckets overlap and are so shaped that they will carry coal around three sides of a rectangle. The coal is carried to any desired point and is discharged by completely inverting the bucket over a turn-wheel.

*Pivoted bucket-carriers* consist of two strands of long pitch steel chain to which are attached, in a pivotal manner, large malleable iron or steel buckets so arranged that their adjacent lips are close together or overlap. Overlapping buckets require special devices for changing the lap at the corner turns. Carriers in which the buckets do not overlap should be fitted with auxiliary pans or buckets, arranged in such a manner as to catch the spill which falls between the lips at the loading point, and so shaped as to return the spill to the buckets at the corner turns. Pivoted bucket-carriers will carry coal around four sides of a rectangle, the buckets being dumped on the horizontal run by striking a cam suitably placed. Buckets for these carriers are usually of 2 ft. pitch, and range in width from 18 in. to 48 in. They run at low speeds, usually not over 50 ft. per minute, 40 ft. per minute being most usual. At the latter speed, the capacities when handling coal vary from 40 tons per hour for the 18 in. width to 120 tons for the 48 in. width. On account of the superior construction of these carriers and the slow speed at which they run, they are economical of power and durable. The rollers mounted on the chain joints are usually 6 in. diameter, but for severe duty 8-in. rollers are often used. It is usual to make these hollow to carry a quantity of oil for internal lubrication.

**Coal Conveyors.** — Coal conveyors are of four general types, viz., scraper or flight, bucket, screw, and belt conveyors.

*The flight conveyor* consists of a trough of any desired cross-section and a single or double strand of chain carrying scrapers or flights of approximately the same shape as the trough. The flights push the coal ahead of them in the trough to any desired point, where it is discharged through openings in the bottom of the trough.

For short, low-capacity conveyors, malleable link hook-joint chains are used. For heavier service, malleable pin-joint chains, steel link chains, or monobar, are required. For the heaviest service, two strands of steel link chain, usually with rollers, are used.

Flight conveyors are of three types: plain scraper, suspended flight, and roller flight.

In the plain scraper conveyor, the flight is suspended from the chain and drags along the bottom of the trough. It is of low first cost and is useful where noise of operation is not objectionable. It has a maximum capacity of about 30 tons per hour, and requires more power than either of the other two types of flight conveyors.

*Suspended flight conveyors* use one or two strands of chain. The flights are attached to cross-bars having wearing-shoes at each end. These wearing-shoes slide on angle-iron tracks on each side of the conveyor trough. The flights do not touch the trough at any point. This type of conveyor is used where quietness of operation is a consideration. It is of higher first cost than the plain scraper conveyor, but requires one-fourth less power for operation. It is economical up to a capacity of about 80 tons per hour.

The roller flight conveyor is similar to the suspended flight, except that the wearing-shoes are replaced by rollers. It is highest in first cost of all the flight conveyors, but has the advantages of low power consumption (one-half that of the scraper), low stress in chain, long life of chain, trough, and flights, and noiseless operation. It has an economical maximum capacity of about 120 tons per hour.

The following formula gives approximately the horse-power at the head wheel required to operate flight conveyors:

$$\text{H.P.} = (\text{ATL} + \text{BWS}) \div 1000.$$

$T$  = tons of coal per hour;  $L$  = length of conveyor in feet, center to center;  $W$  = weight of chain, flights, and shoes (both runs) in pounds;  $S$  = speed in feet per minute;  $A$  and  $B$  constants depending on angle of incline from horizontal. See example below.

EXAMPLE.—Required the H.P. for a monobar conveyor 200 ft. center to center carrying 100 tons of coal per hour, up a  $10^\circ$  incline at a speed of 100 feet per minute. Conveyor has No. 818 chain and  $8 \times 19$  suspended flights, spaced 18 inches apart.

$$\text{H.P.} = \frac{0.5 \times 100 \times 200 + 0.008 (400 \times 5.7 + 267 \times 15.55) \times 100}{1000} = 15.15.$$

The following table shows the conveying capacities of various sizes of flights at 100 feet per minute in tons, of 2000 lb., per hour. The values are true for continuous feed only.

Size of Flight.	Horizontal Conveyors, Tons.				Inclined Conveyors, Tons.		
	Flight Every 16".	Flight Every 18".	Flight Every 24".	Pounds Coal per Flight.	$10^\circ$ Flights Every 24".	$20^\circ$ Flights Every 24".	$30^\circ$ Flights Every 24".
$6 \times 14$	69.75	62	46.5	31	40.5	31.5	22.5
$8 \times 19$	.....	130	97.5	65	78	62	52
$10 \times 24$	.....	.....	172.5	115	150	120	90
$10 \times 30$	.....	.....	220	147	184	146	116
$10 \times 36$	.....	.....	268	179	225	177	142
$10 \times 42$	.....	.....	315	210	264	210	167

**Bucket Conveyors.** — Rigid bucket-carriers are used to convey large quantities of coal over a considerable distance when there is no intermediate point of discharge. These conveyors are made with two strands of steel roller chain. They are built to carry as much as 10 tons of coal per minute.

**Screw Conveyors.** — Screw conveyors consist of a helical steel flight, either in one piece or in sections, mounted on a pipe or shaft, and running in a steel or wooden trough. These conveyors are made from 4 to 18 inches in diameter, and in sections 8 to 12 feet long. The speed ranges from 20 to 60 revolutions per minute and the capacity from 10 to 30 tons of coal per hour. It is not advisable to use this type of conveyor for coal, as it will only handle the smaller sizes and the flights are very easily damaged by any foreign substance of unusual size or shape.

**Belt Conveyors.** — Rubber and cotton belt conveyors are used for handling coal, ore, sand, gravel etc., in all sizes. They combine a high carrying capacity with low power consumption.

In some cases the belt is flat, the material being fed to the belt at its center in a narrow stream. In the majority of cases, however, the belt is troughed by means of idler pulleys set at an angle from the horizontal and placed at intervals along the length of the belt. Rubber belts are often made more flexible for deep troughing by removing some of the layers of cotton from the belt and substituting therefor an extra thickness of rubber.

Belt conveyors may be used for elevating materials up to about  $23^\circ$  incline. On greater inclines the material slides back on the belt and spills. With many substances it is important to feed the belt steadily if the conveyor stands at or near the limiting angle. If the flow is interrupted the material may slide back on the belt.

Belt conveyors are run at any speed from 200 to 800 feet per minute, and are made in widths varying from 12 inches to 60 inches.



Values of A and B.

Angle, Deg.	A	B	Angle, Deg.	A	B	Angle, Deg.	A	B
0	0.343	0.01	10	0.50	0.01	30	0.79	0.009
2	0.378	0.01	14	0.57	0.01	34	0.84	0.008
4	0.40	0.01	18	0.63	0.009	38	0.88	0.008
6	0.44	0.01	22	0.69	0.009	42	0.92	0.007
8	0.47	0.01	26	0.74	0.009	46	0.95	0.007

For suspended flight conveyors take B as 0.8 and for roller flights as 0.6, of the values given in the table.

Weight of Chain in Pounds per Foot.

LINK-BELTING.					MONOBAR.							
Chain No.	Pitch of Flights, Inches.				Chain No.*	Pitch of Flights, Inches.						
	12	18	24	36		12	18	24	36	48	54	72
78	2.4	2.3	2.26	2.2	612	3.9	...	3.6	3.5	.....	.....	.....
88	2.8	2.7	2.6	2.5	618	....	3.0	....	2.8	.....	2.7	.....
85	3.1	2.8	2.7	2.6	818	....	5.7	....	5.5	.....	5.3	.....
103	4.6	4.4	4.3	4.2	824	....	....	4.9	....	4.7	.....	4.6
108	4.9	4.7	4.4	4.1	1018	....	11.5	....	10.7	.....	10.4	.....
110	5.6	5.2	4.9	4.7	1024	....	....	9.6	....	9.07	.....	8.8
114	6.3	6.0	5.9	5.7	1224	....	....	14.7	....	14.04	.....	13.8
122	8.1	7.7	7.4	7.2	1236	....	....	....	11.8	.....	.....	11.34
124	8.9	8.4	8.2	7.9	1424	....	....	20.5	....	19.7	.....	19.4

\* In monobar the first one or two figures in the number of the chain denote the diameter of the chain in eighths of an inch. The last two figures denote the pitch in inches.

PIN CHAINS.					ROLLER CHAINS.							
No.	Pitch of Flights, Inches.				No.	Pitch of Flights, Inches.						
	12	18	24	36		12	18	24	36			
720	5.9	5.6	5.4	5.3	1112	7.7	6.9	6.2	5.7			
730	6.9	6.6	6.4	6.3	1113	9.5	8.8	8.0	7.5			
825	9.6	9.3	9.1	8.9	1130	10.5	9.5	9.0	7.8			

Weight of Flights with Wearing-shoes and Bolts.

Size, Inches.	Steel.	Malleable Iron.	Suspended Flights.	
			Size.	Weight, Lb.
4×10	3.5	4.3	6×14	12.37
4×12	3.9	4.7	8×19	15.55
5×10	4.1	5.2	10×24	25.57
5×12	4.6	5.7	10×30	29.37
5×15	5.8	5.9	10×36	33.17
6×18	8.1	9.2	10×42	34.97
8×18	10.1	12.7		
8×20	11.0	13.4		
8×24	12.6	14.4		
10×24	15.2	17.4		

Capacity of Belt Conveyors in Tons of Coal per Hour.

Width of Belt, Ins.	Velocity, Feet per Minute.			Width of Belt, Ins.	Velocity, Feet per Minute.				
	300	350	400		300	350	400	450	500
12	34			20	96	112	128		
14	47			24	139	162	186	210	
16	62	72	82	30	218	254	290	326	
18	78	91	104	36	315	368	420	472	520

For materials other than coal, the figures in the above table should be multiplied by the coefficients given in the table below:

Material.	Coefficient.	Material.	Coefficient.
Ashes (damp).....	0.86	Earth.....	1.4
Cement.....	1.76	Sand.....	1.8
Clay.....	1.26	Stone (crushed).....	2.0
Coke.....	0.60		

**Belt Conveyor Construction.** (C. K. Baldwin, *Trans. A. S. M. E.*, 1908.)—The troughing idlers should be spaced as follows, depending on the weight of the material carried:

Belt width	12–16 in.	18–22 in.	24–30 in.	32–36 in.
Spacing, ft.	4½–5	4–4½	3½–4	3–3½

The stress in the belt should not exceed 18 to 20 lb. per inch of width per ply with rubber belts. This may be increased about 20% with belts in which 28 oz. duck is used. Where the power required is small the stiffness of the belt fixes the number of plies. The minimum number of plies is as follows:

Belt width, in.	12–14	16–20	22–28	30–36
Minimum plies	3	4	5	6

Pulleys of small diameter should be avoided on heavy belts, or the constant bending of the belt under heavy stress will cause the friction to lose its hold and destroy the belt. In many cases it is advisable to cover the driving pulley with a rubber lagging to increase the tractive power, particularly in dusty places. The minimum size of driving pulleys to be used is shown in the table below.

**Smallest Diameter of Driving Pulleys for Belt Conveyors.**

Width of Belt.	Diameter of Pulley.	Width of Belt.	Diameter of Pulley.	Width of Belt.	Diameter of Pulley.
In.	In.	In.	In.	In.	In.
12	16–18	22	20–30	32	30–36
14	16–18	24	24–30	34	30–42
16	20–24	26	24–30	36	30–48
18	20–24	28	24–30	.....	.....
20	20–24	30	30–36	.....	.....

**Horse-power to Drive Belt Conveyors.** (C. K. Baldwin, *Trans. A. S. M. E.*, 1908.) — The power required to drive a belt conveyor depends on a great variety of conditions, as the spacing of idlers, type of drive, thickness of belt, etc. In figuring the power required, the belt should run no faster than is necessary to carry the desired load. If it should be necessary to increase the speed, the load should be increased in proportion and the power figured accordingly.

For level conveyors H.P. =  $C \times T \times L \div 1000$ .

For inclined conveyors

$$H.P. = (C \times T \times L \div 1000) + (T \times H \div 1000).$$

$C$  = power constant from table below;  $T$  = load, tons per hour;  $L$  = length of conveyor, center to center, ft.;  $H$  = vertical height material is lifted, ft.;  $S$  = belt speed, ft. per minute;  $B$  = width of belt, in.

For each movable or fixed tripper add horse-power in column 3 of table. Add 20% to horse-power for each conveyor under 50 ft. long. Add 10% to horse-power for each conveyor between 50 ft. and 100 ft. long. The formulæ above do not include gear friction, should the conveyor be gear-driven.

When horse-power and speed are known the stress in the belt in pounds per inch of width is

$$\text{Stress} = \frac{H.P. \times 33,000}{S \times B}.$$

From this the number of plies can be found, using 20 lb. per ply per inch of width as a maximum for rubber belts.

**Relative Wearing Power of Conveyor Belts.** (T. A. Bennett, *Trans. A. S. M. E.*, 1908.)—Different materials used in the construction

## Constants for Formulæ for Belt Conveyors.

Width of Belt, In.	1	2	3	4	5
	C for Material Weighing from 25 Lb. to 75 Lb. per Cu. Ft.	C for Material Weighing from 75 Lb. to 125 Lb. per Cu. Ft.	H.P. Required for Each Movable or Fixed Tripper.	Minimum Plies of Belt.	Maximum Plies of Belt.
12	0.234	0.147	1/2	3	4
14	0.226	0.143	1/2	3	4
16	0.220	0.140	3/4	4	5
18	0.209	0.138	1	4	5
20	0.205	0.136	1 1/4	4	6
22	0.199	0.133	1 1/2	5	6
24	0.195	0.131	1 3/4	5	7
26	0.187	0.127	2	5	7
28	0.175	0.121	2 1/4	5	8
30	0.167	0.117	2 1/2	6	8
32	0.163	0.115	2 3/4	6	9
34	0.161	0.114	3	6	10
36	0.157	0.112	3 1/4	6	10

of conveyors were subjected to the uniform action of a sand blast for 45 minutes, and the relative abrasive resisting qualities were found to be as follows, taking the volume of rubber belt worn away as 1.0:

Rubber belt.....	1.0	Woven cotton belt, high grade	6.5
Rolled steel bar.....	1.5	Stitched duck, high grade	8.0
Cast iron.....	3.5	Woven cotton belt, low grade	9.0 to 15.0
Balata belt, including gum cover	5.0		

A *Symposium on Hoisting and Conveying* was presented at the Detroit meeting of the A. S. M. E., 1908 (*Trans.*, vol. xxx.), in papers by G. E. Titcomb, S. B. Peck, C. K. Baldwin, C. J. Tomlinson and E. J. Haddock. Among the subjects discussed are the loading and unloading of cargo steamers; car unloaders; storing of ore and coal; continuous conveying of merchandise; conveying in a Portland cement plant, and suspension cableways.

## PNEUMATIC CONVEYING

**Pneumatic Conveying.**—A pneumatic conveying system consists of a pipe line, a feeding hopper, a blower or exhaustor, and a receiver. It is used for conveying grain, slack coal, sawdust, shavings, and other light material. Grain has been carried over 2,000 ft. horizontally and raised to any desired height. The pressure system is simpler and requires less pipe than the vacuum system, but the latter is more common and is adapted to a greater variety of conditions. The principal advantages of the pneumatic system, as against all types of mechanical conveyors, are simplicity, adaptability to peculiar conditions, the little attention required, few repairs, and shut-downs. (For details of apparatus, etc., see bulletins of the Connorsville Blower Co.)

**Pneumatic Postal Transmission.**—A paper by A. Falkenau (Eng's Club of Philadelphia, April, 1894), entitled the "First United States Pneumatic Postal System," gives a description of the system used in London and Paris, and that recently introduced in Philadelphia between the main post-office and a substation. In London the tubes are 2 1/4 and 3-inch lead pipes laid in cast-iron pipes for protection. The carriers used in 2 1/4-inch tubes are but 1 1/4 inches diameter, the remaining space being taken up by packing. Carriers are despatched singly. First, vacuum alone was used; later, vacuum and compressed air. The tubes used in the Continental cities in Europe are wrought iron, the Paris tubes being 2 1/2 inches diameter. There the carriers are despatched in trains of six to ten, propelled by a piston. In Philadelphia the size of tube adopted is 6 1/8 inches, the tubes being of cast iron bored to size. The lengths of the outgoing and return tubes are 2928 feet each. The pressure



at the main station is 7 lb., at the substation 4 lb., and at the end of the return pipe atmospheric pressure. The compressor has two air-cylinders 18 × 24 in. Each carrier holds about 200 letters, but 100 to 150 are taken as an average. Eight carriers may be despatched in a minute, giving a delivery of 48,000 to 72,000 letters per hour.\* The time required in transmission is about 57 seconds.

Pneumatic postal transmission tubes were laid in 1898 by the Batcheller Pneumatic Tube Co. between the general post-offices in New York and Brooklyn, crossing the East River on the Brooklyn bridge. The tubes are cast iron, 12-ft. lengths, bored to 8<sup>1</sup>/<sub>8</sub> in. diameter. The joints are bells, calked with lead and yarn. There are two tubes, one operating in each direction. Both lines are operated by air-pressure above the atmospheric pressure. One tube is operated by an air-compressor in the New York office and the other by one located in the Brooklyn office.

The carriers are 24 in. long, in the form of a cylinder 7 in. diameter, and are made of steel, with fibrous bearing-rings which fit the tube. Each carrier will contain about 600 ordinary letters, and they are despatched at intervals of 10 seconds in each direction, the time of transit between the two offices being 3<sup>1</sup>/<sub>2</sub> minutes, the carriers travelling at a speed of from 30 to 35 miles per hour.

One of the air-compressors is of the duplex type and has two steam-cylinders 10 × 20 in. and two air-cylinders 24 × 20 in., delivering 1570 cu. ft. of free air per minute, at 75 r.p.m. The power is about 50 H.P.

Two other duplex air-compressors have steam-cylinders 14 × 18 in. and air-cylinders 26<sup>1</sup>/<sub>4</sub> × 18 in. They are designed for 80 to 90 r.p.m. and to compress to 20 lb. per sq. in.

Another double line of pneumatic tubes has been laid between the main office and Postal Station H, Lexington Ave. and 44th St., in New York City. This line is about 3<sup>1</sup>/<sub>2</sub> miles in length. There are three intermediate stations. The carriers can be so adjusted when they are put into the tube that they will traverse the line and be discharged automatically from the tube at the station for which they are intended. The tubes are of the same size as those of the Brooklyn line and are operated in a similar manner. The initial air-pressure is about 12 to 15 lb. On the Brooklyn line it is about 7 lb.

There is also a tube system between the New York Post-office and the Produce Exchange. For a very complete description of the system and its machinery see "The Pneumatic Despatch Tube System," by B. C. Batcheller, J. B. Lippincott Co., Philadelphia, 1897.

### WIRE-ROPE HAULAGE.

Methods for transporting coal and other products by means of wire rope, though varying from each other in detail, may be grouped in five classes:

- I. The Self-acting or Gravity Inclined Plane.
- II. The Simple Engine-plane.
- III. The Tail-rope System.
- IV. The Endless-rope System.
- V. The Cable Tramway.

The following brief description of these systems is abridged from a pamphlet on Wire-rope Haulage, by Wm. Hildenbrand, C.E., published by John A. Roebling's Sons Co., Trenton, N. J.

**I. The Self-acting Inclined Plane.**—The motive power for the self-acting inclined plane is gravity; consequently this mode of transporting coal finds application only in places where the coal is conveyed from a higher to a lower point and where the plane has sufficient grade for the loaded descending cars to raise the empty cars to an upper level.

At the head of the plane there is a drum, which is generally constructed of wood, having a diameter of seven to ten feet. It is placed high enough to allow men and cars to pass under it. Loaded cars coming from the pit are either singly or in sets of two or three switched on the track of the plane, and their speed in descending is regulated by a brake on the drum.

Supporting rollers, to prevent the rope dragging on the ground, are

\* A report of a U. S. Postal Commission states that up to the present time (1910), the sending and receiving apparatus does not permit the successful operation of carrier service with an interval of less than 13 to 15 seconds between carriers, for 6- and 8-in. tubes.

generally of wood, 5 to 6 in. in diameter and 18 to 24 in. long, with  $\frac{3}{4}$  to  $\frac{7}{8}$  in. iron axles. The distance between the rollers varies from 15 to 30 ft., steeper planes requiring less rollers than those with easy grades. Considering only the reduction of friction and what is best for the preservation of rope, a general rule may be given to use rollers of the greatest possible diameter, and to place them as close as economy will permit.

The smallest angle of inclination at which a plane can be made self-acting will be when the motive and resisting forces balance each other. The motive forces are the weights of the loaded car and of the descending rope. The resisting forces consist of the weight of the empty car and ascending rope, of the rolling and axle friction of the cars, and of the axle friction of the supporting rollers. The friction of the drum, stiffness of rope, and resistance of air may be neglected. A general rule cannot be given, because a change in the length of the plane or in the weight of the cars changes the proportion of the forces; also, because the coefficient of friction, depending on the condition of the road, construction of the cars, etc., is a very uncertain factor.

For working a plane with a  $\frac{5}{8}$ -in. steel rope and lowering from one to four pit cars weighing empty 1400 lb. and loaded 4000 lb., the rise in 100 ft. necessary to make the plane self-acting will be from about 5 to 10 ft., decreasing as the number of cars increase, and increasing as the length of plane increases.

A gravity inclined plane should be slightly concave, steeper at the top than at the bottom. The maximum deflection of the curve should be at an inclination of 45 degrees, and diminish for smaller as well as for steeper inclinations.

**II. The Simple Engine-plane.** — The name "Engine-plane" is given to a plane on which a load is raised or lowered by means of a single wire rope and stationary steam-engine. It is a cheap and simple method of conveying coal underground, and therefore is applied wherever circumstances permit it. Under ordinary conditions such as prevail in the Pennsylvania mine region, a train of twenty-five to thirty loaded cars will descend, with reasonable velocity, a straight plane 5000 ft. long on a grade of  $1\frac{3}{4}$  ft. in 100, while it would appear that  $2\frac{1}{4}$  ft. in 100 is necessary for the same number of empty cars. For roads longer than 5000 ft. or containing sharp curves, the grade should be correspondingly larger.

**III. The Tail-rope System.** — Of all methods for conveying coal underground by wire rope, the tail-rope system has found the most application. It can be applied under almost any condition. The road may be straight or curved, level or undulating, in one continuous line or with side branches. In general principle a tail-rope plane is the same as an engine-plane worked in both directions with two ropes. One rope, called the "main rope," serves for drawing the set of full cars outward; the other, called the "tail-rope," is necessary to take back the empty set, which on a level or undulating road cannot return by gravity. The two drums may be located at the opposite ends of the road, and driven by separate engines, but more frequently they are on the same shaft at one end of the plane. In the first case each rope would require the length of the plane, but in the second case the tail rope must be twice as long, being led from the drum around a sheave at the other end of the plane and back again to its starting-point. When the main rope draws a set of full cars out, the tail-rope drum runs loose on the shaft, and the rope, being attached to the rear car, unwinds itself steadily. Going in, the reverse takes place. Each drum is provided with a brake to check the speed of the train on a down grade and prevent its overrunning the forward rope. As a rule, the tail rope is strained less than the main rope, but in cases of heavy grades dipping outward it is possible that the strain in the former may become as large, or even larger, than in the latter, and in the selection of the sizes reference should be had to this circumstance.

**IV. The Endless-rope System.** — The principal features of this system are as follows:

1. The rope, as the name indicates, is endless.
2. Motion is given to the rope by a single wheel or drum, and friction is obtained either by a grip-wheel or by passing the rope several times around the wheel.
3. The rope must be kept constantly tight, the tension to be produced by artificial means. It is done in placing either the return-wheel or an extra tension wheel on a carriage and connecting it with a weight hanging over a pulley, or attaching it to a fixed post by a screw which occasionally can be

shortened. 4. The cars are attached to the rope by a grip or clutch, which can take hold at any place and let go again, starting and stopping the train at will, without stopping the engine or the motion of the rope. 5. On a single-track road the rope works forward and backward, but on a double track it is possible to run it always in the same direction, the full cars going on one track and the empty cars on the other.

This method of conveying coal, as a rule, has not found as general an introduction as the tail-rope system, probably because its efficacy is not so apparent and the opposing difficulties require greater mechanical skill and more complicated appliances. Its advantages are, first, that it requires one-third less rope than the tail-rope system. This advantage, however, is partially counterbalanced by the circumstance that the extra tension in the rope requires a heavier size to move the same load than when a main and tail rope are used. The second and principal advantage is that it is possible to start and stop trains at will without signaling to the engineer. On the other hand, it is more difficult to work curves with the endless system, and still more so to work different branches, and the constant stretch of the rope under tension or its elongation under changes of temperature frequently causes the rope to slip on the wheel, in spite of every attention, causing delay in the transportation and injury to the rope.

### Stress in Hoisting-ropes on Inclined Planes.

(Trenton Iron Co., 1906.)

Rise per 100 Ft. Horizontal.	Angle of Inclination.	Stress in Lb. per Ton of 2000 Lb.	Rise per 100 Ft. Horizontal.	Angle of Inclination.	Stress in Lb. per Ton of 2000 Lb.	Rise per 100 Ft. Horizontal.	Angle of Inclination.	Stress in Lb. per Ton of 2000 Lb.
Ft.			Ft.			Ft.		
5	2° 52'	140	55	28° 49'	1003	110	47° 44'	1516
10	5° 43'	240	60	30° 58'	1067	120	50° 12'	1573
15	8° 32'	336	65	33° 02'	1128	130	52° 26'	1620
20	11° 18'	432	70	35° 00'	1185	140	54° 28'	1663
25	14° 03'	527	75	36° 53'	1238	150	56° 19'	1699
30	16° 42'	613	80	38° 40'	1287	160	58° 00'	1730
35	19° 18'	700	85	40° 22'	1332	170	59° 33'	1758
40	21° 49'	782	90	42° 00'	1375	180	60° 57'	1782
45	24° 14'	860	95	43° 32'	1415	190	62° 15'	1804
50	26° 34'	933	100	45° 00'	1454	200	63° 27'	1822

The above table is based on an allowance of 40 lb. per ton for rolling friction, but an additional allowance must be made for stress due to the weight of the rope proportional to the length of the plane. A factor of safety of 5 to 7 should be taken.

In hoisting the slack-rope should be taken up gently before beginning the lift, otherwise a severe extra strain will be brought on the rope.

**V. Wire-rope Tramways.** — The methods of conveying products on a suspended rope tramway find especial application in places where a mine is located on one side of a river or deep ravine and the loading station on the other. A wire rope suspended between the two stations forms the track on which material in properly constructed "carriages" or "buggies" is transported. It saves the construction of a bridge or trestlework and is practical for a distance of 2000 feet without an intermediate support.

There are two distinct classes of rope tramways:

1. The rope is stationary, forming the track on which a bucket holding the material moves forward and backward, pulled by a smaller endless wire rope. 2. The rope is movable, forming itself an endless line, which serves at the same time as supporting track and as pulling rope.

Of these two the first method has found more general application, and is especially adapted for long spans, steep inclinations, and heavy loads.



The second method is used for long distances, divided into short spans, and is only applicable for light loads delivered at regular intervals.

For detailed descriptions of the several systems of wire-rope transportation, see circulars of John A. Roebling's Sons Co., The Trenton Iron Co., A. Leschen & Sons Rope Co. See also paper on Two-rope Haulage Systems, by R. Van A. Norris, *Trans. A. S. M. E.*, xii. 626.

In the *Bleichert System* of wire-rope tramways, in which the track rope is stationary, loads up to 2000 lb. are carried at a speed of 3 to 4 miles per hour. While the average spans on a level are from 150 to 200 ft., in crossing rivers, ravines, etc., spans up to 1500 ft. are frequently adopted. In a tramway on this system at Bingham, Utah, the total length of the line is 12,700 ft. with a fall of 1120 ft. The line operates by gravity and carries 35 tons per hour. The cost of conveying on this carrier is 7<sup>3</sup>/<sub>4</sub> cents per ton of 2000 lb. for labor and repairs, without any apparent deterioration in the condition of track cables and traction rope.

The *Aerial Wire-rope Tramway* of A. Leschen & Sons Co. is of the double-rope type, in which the buckets travel upon stationary track cables and are propelled by an endless traction rope. The buckets are attached to the traction rope by means of clips — spaced according to the desired tonnage. The hold on the rope is positive, but the clip is easily removable. The bucket is held in its normal position in the frame by two malleable iron latches — one on each side. A tripping bar engages these latches at the unloading terminal when the bucket discharges its material. This operation is automatic and takes place while the carriers are moving. At the loading terminal, the bucket is automatically returned to its normal position and latched. Special carriers are provided for the accommodation of any class of material. At each of the terminal stations is a 10-ft. sheave wheel around which the traction rope passes, these wheels being provided with steel grids for the control of the traction rope. When the loaded carriers travel down grade and the difference in elevation is sufficient, this tramway will operate by the force due to gravity, otherwise the power is applied to the sheaves through bevel gearing. Numerous modifications of the system are in use to suit different conditions.

An *Aerial Tramway 21.5 miles long*, with an elevation of the loading end above the discharging end of 11,500 ft., built by A. Bleichert & Co. for the government of the Argentine Republic, connecting the mines of La Mejicana with the town of Chilecito, is described by Wm. Hewitt in *Indust. Eng.*, Aug. 15, 1909. Some of the inclinations are as much as 45 deg., there are some spans nearly 3000 ft. long, and there is a tunnel nearly 500 ft. long. The line is divided into eight sections, each with an independent traction rope. The gravity of the descending loaded carriers is sufficient to make the line self-operating when it is once set in motion, but in order to ensure full control, and to provide for carrying four tons upward while the descending carriers are empty, four steam engines are installed, one for each two sections. The carriers hold 10 cu. ft., or about 1100 lbs. of ore. The speed is 500 ft. per minute, and the interval between carriers 45 seconds. The stress in the traction rope is as high as 11,000 lbs. in some sections.

### Suspension Cableways or Cable Hoist-conveyors.

(Trenton Iron Co.)

In quarrying, rock-cutting, stripping, piling, dam-building, and many other operations where it is necessary to hoist and convey large individual loads economically, it frequently happens that the application of a system of derricks is impracticable, by reason of the limited area of their efficiency and the room which they occupy. To meet such conditions cable hoist-conveyors are adopted, as they can be operated in clear spans up to 1500 ft., and in lifting individual loads up to 15 tons. Two types are made — one in which the hoisting and conveying are done by separate running ropes, and the other applicable only to inclines in which the carriage descends by gravity, and but one running rope is required. The moving of the carriage in the former is effected by means of an endless rope, and these are commonly known as "endless-rope" hoist-conveyors to distinguish them from the latter, which are termed "inclined" hoist-conveyors.

The general arrangement of the endless-rope hoist-conveyors consists of a main cable passing over towers, A-frames or masts, as may be most convenient, and anchored firmly to the ground at each end, the requisite tension in the cable being maintained by a turnbuckle at one anchorage.

Upon this cable travels the carriage, which is moved back and forth over the line by means of the endless rope. The hoisting is done by a separate rope, both ropes being operated by an engine specially designed for the purpose, which may be located at either end of the line, and is constructed in such a way that the hoisting-rope is coiled up or paid out automatically as the carriage is moved in and out. Loads may be picked up or discharged at any point along the line. Where sufficient inclination can be obtained in the main cable for the carriage to descend by gravity, and the loading and unloading are done at fixed points, the endless rope can be dispensed with. The carriage, which is similar in construction to the carriage used in the endless-rope cableways, is arrested in its descent by a stop-block, which may be clamped to the main cable at any desired point, the speed of the descending carriage being under control of a brake on the engine-drum.

A *Double-suspension Cableway*, carrying loads of 15 tons, erected near Williamsport, Pa., by the Trenton Iron Co., is described by E. G. Spilsbury in *Trans. A. I. M. E.*, xx. 766. The span is 733 ft., crossing the Susquehanna River. Two steel cables, each 2 in. diam., are used. On these cables runs a carriage supported on four wheels and moved by an endless cable 1 inch in diam. The load consists of a cage carrying a railroad-car loaded with lumber, the latter weighing about 12 tons. The power is furnished by a 50-H.P. engine, and the trip across the river is made in about three minutes.

A hoisting cableway on the endless-rope system, erected by the Lidgerwood Mfg. Co., at the Austin Dam, Texas, had a single span 1350 ft. in length, with main cable 2½ in. diam., and hoisting-rope 1¾ in. diam. Loads of 7 to 8 tons were handled at a speed of 600 to 800 ft. per minute.

Another, of still longer span, 1650 ft., was erected by the same company at Holyoke, Mass., for use in the construction of a dam. The main cable is the Elliott or locked-wire cable, having a smooth exterior. In the construction of the Chicago Drainage Canal twenty cableways, of 700 ft. span and 8 tons capacity, were used, the towers traveling on rails.

**Tension required to Prevent Slipping of Rope on Drum.** (Trenton Iron Co., 1906.) — The amount of artificial tension to be applied in an endless rope to prevent slipping on the driving-drum depends on the character of the drum, the condition of the rope and number of laps which it makes. If  $T$  and  $S$  represent respectively the tensions in the taut and slack lines of the rope;  $W$ , the necessary weight to be applied to the tail-sheave;  $R$ , the resistance of the cars and rope, allowing for friction;  $n$ , the number of half-laps of the rope on the driving-drum; and  $f$ , the coefficient of friction, the following relations must exist to prevent slipping:

$$T = Se^{fn\pi}, \quad W = T + S, \quad \text{and} \quad R = T - S;$$

$$\text{from which we obtain} \quad W = \frac{e^{fn\pi} + 1}{e^{fn\pi} - 1} R,$$

in which  $e = 2.71828$ , the base of the Napierian system of logarithms.

The following are some of the values of  $f$ :

	Dry.	Wet.	Greasy.
Wire-rope on a grooved iron drum. . . .	0.120	0.085	0.070
Wire-rope on wood-filled sheaves. . . . .	0.235	0.170	0.140
Wire-rope on rubber and leather filling	0.495	0.400	0.205

The importance of keeping the rope dry is evident from these figures.

The values of the coefficient  $\frac{e^{fn\pi} + 1}{e^{fn\pi} - 1}$ , corresponding to the above values of  $f$ , for one up to six half-laps of the rope on the driving-drum or sheaves, are given in the table at the top of p. 1207.

When the rope is at rest the tension is distributed equally on the two lines of the rope, but when running there will be a difference in the tensions of the taut and slack lines equal to the resistance, and the values of  $T$  and  $S$  may be readily computed from the foregoing formulæ.

VALUES OF COEFFICIENT  $(efn\pi + 1) \div (efn\pi - 1)$

$f$	$n =$ Number of Half-laps on Driving-wheel.					
	1	2	3	4	5	6
0.070	9.130	4.623	3.141	2.418	1.999	1.729
0.085	7.536	3.833	2.629	2.047	1.714	1.505
0.120	5.345	2.777	1.953	1.570	1.358	1.232
0.140	4.623	2.418	1.729	1.416	1.249	1.154
0.170	3.833	2.047	1.505	1.268	1.149	1.085
0.205	3.212	1.762	1.338	1.165	1.083	1.043
0.235	2.831	1.592	1.245	1.110	1.051	1.024
0.400	1.795	1.176	1.047	1.013	1.004	1.001
0.495	1.538	1.093	1.019	1.004	1.001	1.000

The increase in tension in the endless rope, compared with the main rope of the tail-rope system, where the stress in the rope is equal to the resistance, is about as follows:

$n =$	1	2	3	4	5	6
Increase in tension in endless rope, compared with direct stress %...	40	9	$2\frac{1}{3}$	$\frac{2}{3}$	$\frac{1}{5}$	$\frac{1}{10}$

These figures are useful in determining the size of rope. For instance, if the rope makes two half-laps on the driving drum, the strength of the rope should be 9% greater than a main rope in the tail-rope system.

**General Formulæ for Estimating the Deflection of a Wire Cable Corresponding to a Given Tension.**

(Trenton Iron Co., 1906.)

Let  $s =$  distance between supports or span  $AB$ ;  $m$  and  $n =$  arms into which the span is divided by a vertical through the required point of deflection  $x$ ,  $m$  representing the arm corresponding to the loaded side;  $y =$  horizontal distance from load to point of support corresponding with  $m$ ;  $w =$  wt. of rope per ft.;  $g =$  load;  $t =$  tension;  $h =$  required deflection at any point  $x$ ; all measures being in feet and pounds.

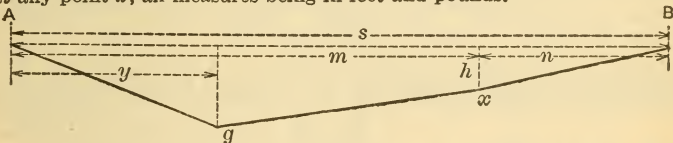

FIG. 191.

For deflection due to rope alone,

$$h = \frac{mnw}{2t} \text{ at } x, \text{ or } \frac{ws^2}{8t} \text{ at center of span.}$$

For deflection due to load alone,

$$h = \frac{gny}{ts} \text{ at } x, \text{ or } \frac{gy}{2t} \text{ at center of span.}$$

If  $y = \frac{1}{2}s$ ,  $h = \frac{gn}{2t}$  at  $x$ , or  $\frac{gs}{4t}$  at center of span.

If  $y = m$ ,  $h = \frac{gmn}{ts}$  at  $x$ , or  $\frac{gs}{4t}$  at center of span.

For total deflection,

$$h = \frac{wmns + 2gny}{2ts} \text{ at } x, \text{ or } \frac{ws^2 + 4gy}{8t} \text{ at center of span.}$$

If  $y = \frac{1}{2}s$ ,  $h = \frac{wmn + gn}{2t}$  at  $x$ , or  $\frac{ws^2 + 2gs}{8t}$  at center of span.

If  $y = m$ ,  $h = \frac{wmns + 2gmn}{2ts}$  at  $x$ , or  $\frac{ws^2 + 2gs}{8t}$  at center of span.

If the tension is required for a given deflection, transpose  $t$  and  $h$  in above formulæ.



**Taper Ropes of Uniform Tensile Strength.** — The true form of rope is not a regular taper but follows a logarithmic curve, the girth rapidly increasing toward the upper end. Mr. Chas. D. West gives the following formula, based on a breaking strain of 80,000 lb. per sq. in. of the rope, core included, and a factor of safety of 10:  $\log G = F \div 3680 + \log g$ , in which  $F$  = length in fathoms, and  $G$  and  $g$  the girth in inches at any two sections  $F$  fathoms apart. The girth  $g$  is first calculated for a safe strain of 8000 lb. per sq. in., and then  $G$  is obtained by the formula. For a mathematical investigation see *The Engineer*, April, 1880, p. 267.

## TRANSMISSION OF POWER BY WIRE ROPE.

The following notes have been furnished to the author by Mr. Wm. Hewitt, Vice-President of the Trenton Iron Co. (See also circulars of the Trenton Iron Co. and of the John A. Roebling's Sons Co., Trenton, N. J.; "Transmission of Power by Wire Ropes," by A. W. Stahl, Van Nostrand's Science Series, No. 28; and Reuleaux's Constructor.)

The load stress or working tension should not exceed the difference between the safe stress and the bending stress as determined by the table on page 1209.

The approximate strength of iron-wire rope composed of wires having a tensile strength of 75,000 to 90,000 lbs. per sq. in. is half that of cast-steel rope composed of wires of a tensile strength of 150,000 to 190,000 lbs. per sq. in. Extra strong steel wires have a tensile strength of 190,000 to 225,000 and plow-steel wires 225,000 to 275,000 lbs. per sq. in.

The 19-wire rope is more flexible than the 7-wire, and for the same load stress may be run around smaller sheaves, but it is not as well adapted to withstand abrasion or surface wear.

The working tension may be greater, therefore, as the bending stress is less; but since the tension in the slack portion of the rope cannot be less than a certain proportion of the tension in the taut portion, to avoid slipping, a ratio exists between the diameter of sheave and the wires composing the rope corresponding to a maximum safe working tension.

This ratio depends upon the number of laps that the rope makes about the sheaves, and the kind of filling in the rims or the character of the material upon which the rope tracks.

For ordinary purposes the maximum safe stress should be about one-third the ultimate, and for shafts and elevators about one-fourth the ultimate. In estimating the stress due to the load for shafts and elevators, allowance should be made for the additional stress due to acceleration in starting. For short inclined planes not used for passengers a factor of safety as low as  $2\frac{1}{2}$  is sometimes used, and for derricks, in which large sheaves cannot be used, and long life of the rope is not expected, the factor of safety may be as low as 2.

The Seale wire rope is made of six strands of 19 wires, laid 9 around 9 around 1, the intermediate layer being smaller than the others. It is intermediate in flexibility between the 7-wire and the ordinary 19-wire rope. (In the Seale cable  $d$  = diam. of larger wires.) All ropes 6 strands each. Extra flexible rope has 8 strands.

The sheaves (Fig. 192), are usually of cast iron, and are made as light as possible consistent with the requisite strength. Various materials have been used for filling the bottom of the groove, such as tarred oakum, jute yarn, hard wood, India-rubber, and leather. The filling which gives the best satisfaction, however, in ordinary transmissions consists of

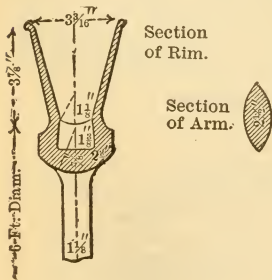

FIG. 192.

Approximate Breaking Strength of Steel-Wire Ropes.

6 Strands of 19 Wires Each.					6 Strands of 7 Wires Each.				
Diam. Rope, In.	Wt. per Ft. Lbs.	Approximate Breaking Stress, Lbs.			Diam. Rope, In.	Wt. per Ft., Lbs.	Approximate Breaking Stress, Lbs.		
		Cast Steel.	Extra Strong Steel.	Plow Steel.			Cast Steel.	Extra Strong Steel.	Plow Steel.
2 1/4	8.00	312,000	364,000	416,000	1 1/2	3.55	136,000	158,000	182,000
2	6.30	248,000	288,000	330,000	1 3/8	3.00	116,000	136,000	156,000
1 3/4	4.85	192,000	224,000	256,000	1 1/4	2.45	96,000	112,000	128,000
1 5/8	4.15	168,000	194,000	222,000	1 1/8	2.00	80,000	92,000	106,000
1 1/2	3.55	144,000	168,000	192,000	1	1.58	64,000	74,000	84,000
1 3/8	3.00	124,000	144,000	164,000	7/8	1.20	48,000	56,000	64,000
1 1/4	2.45	100,000	116,000	134,000	3/4	0.89	37,200	42,000	48,000
1 1/8	2.00	84,000	98,000	112,000	11/16	0.75	31,600	36,800	42,000
1	1.58	68,000	78,000	88,000	5/8	0.62	26,400	30,200	34,000
7/8	1.20	52,000	60,000	68,000	9/16	0.50	21,200	24,600	28,000
3/4	0.89	38,800	44,000	50,000	1/2	0.39	16,800	19,400	22,000
5/8	0.62	27,200	31,600	36,000	7/16	0.30	13,200	15,000	17,100
9/16	0.50	22,000	25,400	29,000	3/8	0.22	9,600	11,160	12,700
1/2	0.39	17,600	20,200	22,800	5/16	0.15	6,800	7,760	.....
7/16	0.30	13,600	15,600	17,700	9/32	0.125	5,600	6,440	.....
3/8	0.22	10,000	11,500	13,100	.....	.....	.....	.....	.....
5/16	0.15	6,800	8,100	.....	.....	.....	.....	.....	.....
1/4	0.10	4,800	5,400	.....	.....	.....	.....	.....	.....

segments of leather and blocks of India-rubber soaked in tar and packed alternately in the groove. Where the working tension is very great, however, the wood filling is to be preferred, as in the case of long-distance transmissions where the rope makes several laps about the sheaves, and is run at a comparatively slow speed.

The Bending Stress is determined by the formula

$$k = \frac{Ea}{2.06 (R \div d) + C}$$

$k$  = bending stress in lbs.;  $E$  = modulus of elasticity = 28,500,000;  $a$  = aggregate area of wires, sq. ins.;  $R$  = radius of bend;  $d$  = diam. of wires, ins.

- For 7-wire rope  $d = 1/9$  diam. of rope;  $C = 9.27$ .
- “ 19-wire “  $d = 1/15$  “ “ “  $C = 15.45$ .
- “ the Seale cable  $d = 1/12$  “ “ “  $C = 12.36$ .

From this formula the tables below and on p. 1210 have been calculated.

Bending Stresses, 7-wire Rope.

Diam. bend.	24	36	48	60	72	84	96	108	120	132
Diam. Rope.										
1/4	826	553	412	333	277	238	208	185	166	151
9/32	1,120	750	563	451	376	323	282	251	226	206
5/16	1,609	1,078	810	649	541	464	406	361	325	296
3/8	2,774	1,859	1,398	1,120	934	801	702	624	562	511
7/16	4,385	2,982	2,217	1,777	1,482	1,272	1,113	990	892	811
1/2	6,200	4,161	3,131	2,510	2,095	1,797	1,574	1,400	1,260	1,146
9/16	9,072	6,095	4,589	3,679	3,071	2,635	2,308	2,053	1,848	1,681
5/8	.....	8,547	6,438	5,164	4,310	3,699	3,240	2,882	2,595	2,360
11/16	.....	10,922	8,230	6,603	5,513	4,731	4,144	3,687	3,320	3,020
3/4	.....	14,202	10,706	8,591	7,174	6,158	5,394	4,799	4,322	3,931
7/8	.....	22,592	17,045	13,685	11,431	9,815	8,599	7,651	6,892	6,269
1	.....	.....	25,476	20,464	17,100	14,686	12,869	11,452	10,317	9,386
1 1/8	.....	.....	36,289	29,165	24,416	20,942	18,355	16,336	14,718	13,391
1 1/4	.....	.....	.....	40,020	33,464	28,754	25,206	22,437	20,216	18,396
1 3/8	.....	.....	.....	.....	44,551	38,290	33,571	29,888	26,933	24,510
1 1/2	.....	.....	.....	.....	57,835	49,718	43,599	38,821	34,987	31,842

Bending Stresses, 19-wire Rope.

Diam.Bend.	12	24	36	48	60	72	84	96	108	120
Diam.Rope.										
1/4	993	502	336	252	202	168	144	126	112	101
5/16	1,863	944	632	475	380	317	272	238	212	191
3/8	2,771	1,406	942	708	567	473	406	355	316	285
7/16	4,859	2,473	1,658	1,247	1,000	834	716	627	557	502
1/2	7,125	3,635	2,440	1,836	1,472	1,228	1,054	923	821	739
9/16	.....	5,319	3,573	2,690	2,157	1,800	1,545	1,353	1,203	1,084
5/8	.....	7,452	5,011	3,774	3,027	2,526	2,169	1,900	1,690	1,522
11/16	.....	9,767	6,572	4,953	3,973	3,317	2,847	2,494	2,219	1,998
3/4	.....	12,512	8,427	6,352	5,098	4,257	3,654	3,201	2,848	2,565
7/8	.....	19,436	13,111	9,891	7,941	6,633	5,696	4,990	4,440	3,999
1	.....	29,799	20,136	15,205	12,214	10,206	8,766	7,681	6,836	6,158
1 1/8	.....	.....	28,153	21,276	17,099	14,293	12,278	10,761	9,578	8,689
1 1/4	.....	.....	38,034	28,766	23,130	19,340	16,618	14,567	12,967	11,683
1 3/8	.....	.....	51,609	39,067	31,430	26,290	22,594	19,811	17,637	15,893
1 1/2	.....	.....	66,065	50,049	40,284	33,707	28,976	25,410	22,625	20,390
1 5/8	.....	.....	.....	62,895	50,647	42,391	36,450	31,969	28,470	25,661
1 3/4	.....	.....	.....	79,749	64,252	53,798	46,270	40,590	36,152	32,589
1 7/8	.....	.....	.....	97,018	78,202	65,500	56,347	49,438	44,039	39,701
2	.....	.....	.....	.....	94,016	78,769	67,778	59,478	52,989	47,777
2 1/4	.....	.....	.....	.....	134,319	112,611	96,943	85,103	75,840	68,396
2 1/2	.....	.....	.....	.....	.....	154,870	133,386	117,137	104,417	94,189

Horse-Power Transmitted. — The general formula for the amount of power capable of being transmitted is as follows:

$$H.P. = [cd^2 - 0.000006 (w + g_1 + g_2)]v;$$

in which  $d$  = diameter of the rope in inches,  $v$  = velocity of the rope in feet per second,  $w$  = weight of the rope,  $g_1$  = weight of the terminal sheaves and shafts,  $g_2$  = weight of the intermediate sheaves and shafts (all in lbs.), and  $c$  = a constant depending on the material of the rope, the filling in the grooves of the sheaves, and the number of laps about the sheaves or drums, a single lap meaning a half-lap at each end. The values of  $c$  for one up to six laps for steel rope are given in the following table:

c = for steel rope on	Number of laps about sheaves or drums					
	1	2	3	4	5	6
Iron.....	5.61	8.81	10.62	11.65	12.16	12.56
Wood.....	6.70	9.93	11.51	12.26	12.66	12.83
Rubber and leather.....	9.29	11.95	12.70	12.91	12.97	13.00

The values of  $c$  for iron rope are one half the above.

When more than three laps are made, the character of the surface in contact is immaterial as far as slippage is concerned.

From the above formula we have the general rule, that the actual horse-power capable of being transmitted by any wire rope approximately equals  $c$  times the square of the diameter of the rope in inches, less six millionths the entire weight of all the moving parts, multiplied by the speed of the rope, in feet per second.

Instead of grooved drums or a number of sheaves, about which the rope makes two or more laps, it is sometimes found more desirable, especially where space is limited, to use grip-pulleys. The rim is fitted with a continuous series of steel jaws, which bite the rope in contact by reason of the pressure of the same against them, but as soon as relieved of this pressure they open readily, offering no resistance to the egress of the rope.

In the ordinary or "flying" transmission of power, where the rope makes a single lap about sheaves lined with rubber and leather or wood, the ratio between the diameter of the sheaves and the wires of the rope, corresponding to a maximum safe working tension, is: For 7-wire rope,



steel, 79.6; iron, 160.5. For 12-wire rope, steel, 59.3; iron, 120. For 19-wire rope, steel, 47.2; iron, 95.8.

**Diameters of Minimum Sheaves in Inches, Corresponding to a Maximum Safe Working Tension.**

Diameter of Rope, In.	Steel.			Iron.		
	7-Wire.	12-Wire.	19-Wire.	7-Wire.	12-Wire.	19-Wire.
1/4	20	15	12	40	30	24
5/16	25	19	15	50	38	30
3/8	30	22	18	60	45	36
7/16	35	26	21	70	53	42
1/2	40	30	24	80	60	48
9/16	45	33	27	90	68	54
5/8	50	37	30	100	75	60
11/16	55	41	32	110	83	66
3/4	60	44	35	120	90	72
7/8	70	52	41	140	105	84
1	80	59	47	160	120	96

Assuming the sheaves to be of equal diameter, and of the sizes in the above table, the *horse-power that may be transmitted by a steel rope making a single lap on wood-filled sheaves* is given in the table below.

The transmission of greater horse-powers than 250 is impracticable with filled sheaves, as the tension would be so great that the filling would quickly cut out, and the adhesion on a metallic surface would be insufficient where the rope makes but a single lap. In this case it becomes necessary to use the Reuleaux method, in which the rope is given more than one lap, as referred to below, under the caption "Long-distance Transmissions."

**Horse-power Transmitted by a Steel Rope on Wood-filled Sheaves.**

Diameter of Rope, In.	Velocity of Rope in Feet per Second.									
	10	20	30	40	50	60	70	80	90	100
1/4	4	8	13	17	21	25	28	32	37	40
5/16	7	13	20	26	33	40	44	51	57	62
3/8	10	19	28	38	47	56	64	73	80	89
7/16	13	26	38	51	63	75	88	99	109	121
1/2	17	34	51	67	83	99	115	130	144	159
9/16	22	43	65	86	106	128	147	167	184	203
5/8	27	53	79	104	130	155	179	203	225	247
11/16	32	63	95	126	157	186	217	245	.....	.....
3/4	38	76	103	150	186	223	.....	.....	.....	.....
7/8	52	104	156	206	.....	.....	.....	.....	.....	.....
1	68	135	202	.....	.....	.....	.....	.....	.....	.....

The *horse-power that may be transmitted by iron ropes is one-half of the above.*

This table gives the amount of horse-power transmitted by wire ropes under maximum safe working tensions. In using wood-lined sheaves, therefore, it is well to make some allowance for the stretching of the rope, and to advocate somewhat heavier equipments than the above table would give; that is, if it is desired to transmit 20 horse-power, for instance, to put in a plant that would transmit 25 to 30 horse-power, avoiding the necessity of having to take up a comparatively small amount of stretch. On rubber and leather filling, however, the amount of power capable of being transmitted is 40 per cent greater than for wood, so that this filling is generally used, and in this case no allowance need be made for stretch, as such sheaves will likely transmit the power given by the table, under all possible deflections of the rope.

Under ordinary conditions, ropes of seven wires to the strand, laid about a hemp core, are best adapted to the transmission of power, but conditions often occur where 12- or 19-wire rope is to be preferred, as stated below, under "Limits of Span."

**Deflections of the Rope.** — The tension of the rope is measured by the amount of sag or deflection at the center at the span, and the deflec-

tion corresponding to the maximum safe working tension is determined by the following formulæ, in which  $S$  represents the span in feet:

		Steel Rope.	Iron Rope.
Def. of still rope at center, in feet. . .	$h$	$= .00004 S^2$	$h = .00008 S^2$
“ driving “ “ “ “ ..	$h_1$	$= .000025 S^2$	$h_1 = .00005 S^2$
“ slack “ “ “ “ ..	$h_2$	$= .0000875 S^2$	$h_2 = .000175 S^2$

**Limits of Span.** — On spans of less than sixty feet, it is impossible to splice the rope to such a degree of nicety as to give exactly the required deflection, and as the rope is further subject to a certain amount of stretch, it becomes necessary in such cases to apply mechanical means for producing the proper tension in order to avoid frequent splicing, which is very objectionable; but care should always be exercised in using such tightening devices that they do not become the means, in unskilled hands, of overstraining the rope. The rope also is more sensitive to every irregularity in the sheaves and the fluctuations in the amount of power transmitted, and is apt to sway to such an extent beyond the narrow limits of the required deflections as to cause a jerking motion, which is very injurious. For this reason on very short spans it is found desirable to use a considerably heavier rope than that actually required to transmit the power; or in other words, instead of a 7-wire rope corresponding to the conditions of maximum tension, it is better to use a 19-wire rope of the same size wires, and to run this under a tension considerably below the maximum. In this way are obtained the advantages of increased weight and less stretch, without having to use larger sheaves, while the wear will be greater in proportion to the increased surface.

In determining the maximum limit of span, the contour of the ground and the available height of the terminal sheaves must be taken into consideration. It is customary to transmit the power through the lower portion of the rope, as in this case the greatest deflection in this portion occurs when the rope is at rest. When running, the lower portion rises and the upper portion sinks, thus enabling obstructions to be avoided which otherwise would have to be removed, or make it necessary to erect very high towers. The maximum limit of span in this case is determined by the maximum deflection that may be given to the upper portion of the rope when running, which for sheaves of 10 ft. diameter is about 600 feet.

Much greater spans than this, however, are practicable where the contour of the ground is such that the upper portion of the rope may be the driver, and there is nothing to interfere with the proper deflection of the under portion. Some very long transmissions of power have been effected in this way without an intervening support, one at Lockport, N.Y., having a clear span of 1700 feet.

**Long-distance Transmissions.** — When the distance exceeds the limit for a clear span, intermediate supporting sheaves are used, with plain grooves (not filled), the spacing and size of which will be governed by the contour of the ground and the special conditions involved. The size of these sheaves will depend on the angle of the bend, gauged by the tangents to the curves of the rope at the points of inflection. If the curvature due to this angle and the working tension, regardless of the size of the sheaves, as determined by the table on the next page, is less than that of the minimum sheave (see table p. 1211), the intermediate sheaves should not be smaller than such minimum sheave, but if the curvature is greater, smaller intermediate sheaves may be used.

In very long transmissions of power, requiring numerous intermediate supports, it is found impracticable to run the rope at the high speeds maintained in “flying transmissions.” The rope therefore is run under a higher working tension, made practicable by wrapping it several times about grooved terminal drums, with a lap about a sheave on a take-up or counter-weighted carriage, which preserves a constant tension in the slack portion.

**Inclined Transmissions.** — When the terminal sheaves are not on the same elevation, the tension at the upper sheave will be greater than that at the lower, but this difference is so slight, in most cases, that it may be ignored. The span to be considered is the horizontal distance between the sheaves, and the principles governing the limits of span will

hold good in this case, so that for every steep inclinations it becomes necessary to resort to tightening devices for maintaining the requisite tension in the rope. The limiting case of inclined transmissions occurs when one wheel is directly above the other. The rope in this case produces no tension whatever on the lower wheel, while the upper is subject only to the weight of the rope, which is usually so insignificant that it may be neglected altogether, and on vertical transmissions, therefore, mechanical tension is an absolute necessity.

**Bending Curvature of Wire Ropes.** — The curvature due to any bend in a wire rope is dependent on the tension, and is not always the same as the sheave in contact, but may be greater, which explains how it is that large ropes are frequently run around comparatively small sheaves without detriment, since it is possible to place these so close that the bending angle on each will be such that the resulting curvature will not overstrain the wires. This curvature may be ascertained from the formula and table below, which give the theoretical radii of curvature in inches for various sizes of ropes and different angles for one pound tension in the rope. Dividing these figures by the square root of the actual tension in pounds, gives the radius of curvature of the rope when this exceeds the curvature of the sheave. The rigidity of the rope or internal friction of the wires and core has not been taken into account in these figures, but the effect of this is insignificant, and it is on the safe side to ignore it. By the "angle of bend" is meant the angle between the tangents to the curves of the rope at the points of inflection. When the rope is straight the angle is 180°. For angles less than 160° the radius of curvature in most cases will be less than that corresponding to the safe working tension, and the proper size of sheave to use in such cases will be governed by the table headed "Diameters of Minimum Sheaves Corresponding to a Maximum Safe Working Tension" on p. 1211.

**Radius of Curvature of Wire Ropes in Inches for 1-lb. Tension.** Formula:  $R^2 = Ed^4n \div 20t (1 - \sin \frac{1}{2} \theta)$ ; in which  $R$  = radius of curvature;  $E$  = modulus of elasticity = 28,500,000;  $d$  = diameter of wires;  $n$  = no. of wires in the rope;  $\theta$  = angle of bend;  $t$  = working stress (lbs. and ins.). Divide by square root of stress in pounds to obtain radius in inches.

Diam. of Rope.		120°	140°	160°	165°	170°	174°	176°	178°	179°
19-Wire Rope.	1/2	38	56	112	149	223	373	559	1126	2181
	5/8	61	91	181	242	362	604	905	1824	3533
	3/4	87	129	257	342	513	856	1282	2586	5007
	7/8	116	174	346	461	690	1151	1725	3479	6737
	1	155	232	461	615	921	1536	2302	4643	8991
	1 1/8	195	290	578	770	1154	1925	2885	5818	11266
7-Wire Rope.	1 1/4	238	355	708	943	1414	2358	3533	7125	13797
	1/2	66	98	196	261	391	651	976	1969	3812
	5/8	103	153	306	407	610	1018	1525	3076	5957
	3/4	145	216	430	572	858	1431	2145	4325	8375
	7/8	198	295	587	782	1172	1954	2929	5907	11438
	1	259	386	769	1024	1535	2559	3835	7735	14978
7-Wire Rope.	1 1/8	328	489	975	1298	1946	3246	4864	9809	18994
	1 1/4	406	605	1205	1606	2407	4013	6015	12129	23487

The 7-wire rope has 6 strands of 7 wires each, the 19-wire rope has 6 strands of 19 wires each.



## ROPE-DRIVING.

The transmission of power by cotton or manila ropes is a competitor with gearing and leather belting when the amount of power is large, or the distance between the power and the work is comparatively great. The following is condensed from a paper by C. W. Hunt, *Trans. A. S. M. E.*, xii, 230:

But few accurate data are available, on account of the long period required in each experiment, a rope lasting from three to six years. Installations which have been successful, as well as those in which the wear of the rope was destructive, indicate that 200 lbs. on a rope one inch in diameter is a safe and economical working strain. When the strain is materially increased, the wear is rapid.

It the following equations

$C$  = circumference of rope, inches;  $g$  = gravity;  
 $D$  = sag of the rope in inches;  $H$  = horse-power;  
 $F$  = centrifugal force in pounds;  $L$  = distance between pulleys, ft.;  
 $P$  = pounds per foot of rope;  $w$  = working strain in pounds;  
 $R$  = force in pounds doing useful work;  
 $S$  = strain in pounds on the rope at the pulley;  
 $T$  = tension in pounds on driving side of the rope;  
 $t$  = tension in pounds on slack side of the rope;  
 $v$  = velocity of the rope in feet per second;  
 $W$  = ultimate breaking strain in pounds.  
 $W = 720 C^2$ ;  $P = 0.032 C^2$ ;  $w = 20 C^2$ .

This makes the normal working strain equal to  $1/36$  of the breaking strength, and about  $1/25$  of the strength at the splice. The actual strains are ordinarily much greater, owing to the vibrations in running, as well as from imperfectly adjusted tension mechanism.

For this investigation we assume that the strain on the driving side of a rope is equal to 200 lbs. on a rope one inch in diameter, and an equivalent strain for other sizes, and that the rope is in motion at various velocities of from 10 to 140 ft. per second.

The centrifugal force of the rope in running over the pulley will reduce the amount of force available for the transmission of power. The centrifugal force  $F = Pv^2 \div g$ .

At a speed of about 80 ft. per second, the centrifugal force increases faster than the power from increased velocity of the rope, and at about 140 ft. per second equals the assumed allowable tension of the rope. Computing this force at various speeds and then subtracting it from the assumed maximum tension, we have the force available for the transmission of power. The whole of this force cannot be used, because a certain amount of tension on the slack side of the rope is needed to give adhesion to the pulley. What tension should be given to the rope for this purpose is uncertain, as there are no experiments which give accurate data. It is known from considerable experience that when the rope runs in a groove whose sides are inclined toward each other at an angle of  $45^\circ$  there is sufficient adhesion when the ratio of the tensions  $T \div t = 2$ .

For the present purpose  $T$  can be divided into three parts: 1. Tension doing useful work; 2. Tension from centrifugal force; 3. Tension to balance the strain for adhesion.

The tension  $t$  can be divided into two parts: 1. Tension for adhesion; 2. Tension from centrifugal force.

It is evident, however, that the tension required to do a given work should not be materially exceeded during the life of the rope.

There are two methods of putting ropes on the pulleys; one in which the ropes are single and spliced on, being made very taut at first, and less so as the rope lengthens, stretching until it slips, when it is respliced. The other method is to wind a single rope over the pulleys as many turns as needed to obtain the necessary horse-power and put a tension pulley to give the necessary adhesion and also take up the wear. The tension  $t$  on one of the ropes required to transmit the normal horse-power for the ordinary speeds and sizes of rope is computed by formula (1), below. The total tension  $T$  on the driving side of the rope is assumed to be the same at all speeds. The centrifugal force, as well as an amount equal to the tension for adhesion on the slack side of the

rope, must be taken from the total tension  $T$  to ascertain the amount of force available for the transmission of power.

It is assumed that the tension on the slack side necessary for giving adhesion is equal to one half the force doing useful work on the driving

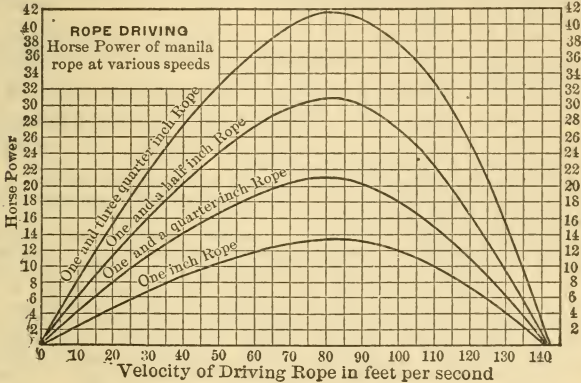

FIG. 193.

side of the rope; hence the force for useful work is  $R = 2/3 (T - F)$ ; and the tension on the slack side to give the required adhesion is  $1/3 (T - F)$ . Hence

$$t = (T - F)/3 + F \dots \dots \dots (1)$$

The sum of the tensions  $T$  and  $t$  is not the same at different speeds, as the equation (1) indicates. As  $F$  varies as the square of the velocity, there is, with an increasing speed of the rope, a decreasing useful force, and an increasing total tension,  $t$ , on the slack side.

With these assumptions of allowable strains the horse-power will be

$$H = 2v (T - F) \div (3 \times 550) \dots \dots \dots (2)$$

Transmission ropes are usually from 1 to 2 inches in diameter. A computation of the horse-power for four sizes at various speeds and under ordinary conditions, based on a maximum strain equivalent to 200 lbs. for a rope one inch in diameter, is given in Fig. 193. The horse-power of other sizes is readily obtained from these. The maximum power is transmitted, under the assumed conditions, at a speed of about 80 feet per second.

The wear of the rope is both internal and external; the internal is caused by the movement of the fibers on each other, under pressure in bending over the sheaves, and the external is caused by the slipping and the wedging in the grooves of the pulley. Both of these causes of wear

**Horse-power of Transmission Rope at Various Speeds.**

Computed from formula (2) given above.

Diam. of Ropes.	Speed of the Rope in feet per minute.										Smallest Diam. of Pulleys in inches.	
	1500	2000	2500	3000	3500	4000	4500	5000	6000	7000		8000
1/2	1.45	1.9	2.3	2.7	3	3.2	3.4	3.4	3.1	2.2	0	20
5/8	2.3	3.2	3.6	4.2	4.6	5.0	5.3	5.3	4.9	3.4	0	24
3/4	3.3	4.3	5.2	5.8	6.7	7.2	7.7	7.7	7.1	4.9	0	30
7/8	4.5	5.9	7.0	8.2	9.1	9.8	10.8	10.8	9.3	6.9	0	36
1	5.8	7.7	9.2	10.7	11.9	12.8	13.6	13.7	12.5	8.8	0	42
1 1/4	9.2	12.1	14.3	16.8	18.6	20.0	21.2	21.4	19.5	13.8	0	54
1 1/2	13.1	17.4	20.7	23.1	26.8	28.8	30.6	30.8	28.2	19.8	0	60
1 3/4	18	23.7	28.2	32.8	36.4	39.2	41.5	41.8	37.4	27.6	0	72
2	23.2	30.8	36.8	42.8	47.6	51.2	54.4	54.8	50	35.2	0	84

are, within the limits of ordinary practice, assumed to be directly proportional to the speed.

The rope is supposed to have the strain  $T$  constant at all speeds on the driving side, and in direct proportion to the area of the cross-section; hence the catenary of the driving side is not affected by the speed or by the diameter of the rope.

The deflection of the rope between the pulleys on the slack side varies with each change of the load or change of the speed, as the tension equation (1) indicates.

The deflection of the rope is computed for the assumed value of  $T$  and  $t$  by the parabolic formula  $S = \frac{PL^2}{8D} + PD$ ,  $S$  being the assumed strain  $T$  on the driving side, and  $t$ , calculated by equation (1), on the slack side. The tension  $t$  varies with the speed.

The following notes are from the circular of the C. W. Hunt Co.:

For a temporary installation, it might be advisable to increase the work to double that given in the table.

For convenience in estimating the necessary clearance on the driving and on the slack sides, we insert a table showing the sag of the rope at different speeds when transmitting the horse-power given in the preceding table. When at rest the sag is not the same as when running, being greater on the driving and less on the slack sides of the rope. The sag of the driving side when transmitting the normal horse-power is the same no matter what size of rope is used or what the speed driven at, because the assumption is that the strain on the rope shall be the same at all speeds when transmitting the assumed horse-power, but on the slack side the strains, and consequently the sag, vary with the speed of the rope and also with the horse-power. The table gives the sag for three speeds. If the actual sag is less than given in the table, the rope is strained more than the work requires.

This table is only approximate, and is exact only when the rope is running at its normal speed, transmitting its full load and strained to the assumed amount. All of these conditions are varying in actual work.

#### SAG OF THE ROPE BETWEEN PULLEYS.

Distance between Pulleys in feet.	Driving Side.		Slack Side of Rope.			
	All Speeds.		80 ft. per sec.	60 ft. per sec.	40 ft. per sec.	
40	0 feet	4 inches	0 feet 7 inches	0 feet 9 inches	0 feet 11 inches	
60	0 "	10 "	1 " 5 "	1 " 8 "	1 " 11 "	
80	1 "	5 "	2 " 4 "	2 " 10 "	3 " 3 "	
100	2 "	0 "	3 " 8 "	4 " 5 "	5 " 2 "	
120	2 "	11 "	5 " 3 "	6 " 3 "	7 " 4 "	
140	3 "	10 "	7 " 2 "	8 " 9 "	9 " 9 "	
160	5 "	1 "	9 " 3 "	11 " 3 "	14 " 0 "	

The size of the pulleys has an important effect on the wear of the rope — the larger the sheaves, the less the fibers of the rope slide on each other, and consequently there is less internal wear of the rope. The pulleys should not be less than forty times the diameter of the rope for economical wear, and as much larger as it is possible to make them. This rule applies also to the idle and tension pulleys as well as to the main driving-pulley.

#### TENSION ON THE SLACK PART OF THE ROPE.

Speed of Rope, in feet per second.	Diameter of the Rope and Pounds Tension on the Slack Rope								
	1/2	5/8	3/4	7/8	1	1 1/4	1 1/2	1 3/4	2
20	10	27	40	54	71	110	162	216	283
30	14	29	42	56	74	115	170	226	296
40	15	31	45	60	79	123	181	240	315
50	16	33	49	65	85	132	195	259	339
60	18	36	53	71	93	145	214	285	373
70	19	39	59	78	101	158	236	310	406
80	21	43	64	85	111	173	255	340	445
90	24	48	70	93	122	190	279	372	487



The angle of the sides of the grooves in which the rope runs varies, with different engineers, from  $45^{\circ}$  to  $60^{\circ}$ . It is very important that the sides of these grooves should be carefully polished, as the fibers of the rope rubbing on the metal as it comes from the lathe tools will gradually break fiber by fiber, and so give the rope a short life. It is also necessary to carefully avoid all sand or blow holes, as they will cut the rope out with surprising rapidity.

Much depends also upon the arrangement of the rope on the pulleys, especially where a tension weight is used. Experience shows that the increased wear on the rope from bending the rope first in one direction and then in the other is similar to that of wire rope. At mines where two cages are used, one being hoisted and one lowered by the same engine doing the same work, the wire ropes, cut from the same coil, are usually arranged so that one rope is bent continuously in one direction and the other rope is bent first in one direction and then in the other, in winding on the drum of the engine. The rope having the opposite bends wears much more rapidly than the other, lasting about three quarters as long as its mate. This difference in wear shows in manila rope, both in transmission of power and in coal-hoisting. The pulleys should be arranged, as far as possible, to bend the rope in one direction.

DIAMETER OF PULLEYS AND WEIGHT OF ROPE.

Diameter of Rope, in inches.	Smallest Diameter of Pulleys, in inches.	Length of Rope to allow for Splicing, in feet.	Approximate Weight, in lbs. per foot of rope.
$\frac{1}{2}$	20	6	0.12
$\frac{5}{8}$	24	6	0.18
$\frac{3}{4}$	30	7	0.24
$\frac{7}{8}$	36	8	0.32
1	42	9	0.49
$1\frac{1}{4}$	54	10	0.60
$1\frac{1}{2}$	60	12	0.83
$1\frac{3}{4}$	72	13	1.10
2	84	14	1.40

For large amounts of power it is common to use a number of ropes lying side by side in grooves, each spliced separately. For lighter drives some engineers use one rope wrapped as many times around the pulleys as is necessary to get the horse-power required, with a tension pulley to take up the slack as the rope wears when first put in use. The weight put upon this tension pulley should be carefully adjusted, as the overstraining of the rope from this cause is one of the most common errors in rope-driving. We therefore give a table showing the proper strain on the rope for the various sizes, from which the tension weight to transmit the horse-power in the tables is easily deduced. This strain can be still further reduced if the horse-power transmitted is usually less than the nominal work which the rope was proportioned to do, or if the angle of groove in the pulleys is acute.

With a given velocity of the driving-rope, the weight of rope required for transmitting a given horse-power is the same, no matter what size rope is adopted. The smaller rope will require more parts, but the weight will be the same.

**Miscellaneous Notes on Rope-Driving.** — Reuleaux gives formulæ for calculating sources of loss in hemp-rope transmission due to (1) journal friction, (2) stiffness of ropes, and (3) creep of ropes. The constants in these formulæ are, however, uncertain from lack of experimental data. He calculates an average case giving loss of power due to journal friction = 4%, to stiffness 7.8%, and to creep 5%, or 16.8% in all, and says this is not to be considered higher than the actual loss.

Spencer Miller, in a paper entitled "A Problem in Continuous Rope-driving" (*Trans. A. S. C. E.*, 1897), reviews the difficulties which occur in rope-driving, with a continuous rope from a large to a small pulley. He adopts the angle of  $45^{\circ}$  as a minimum angle to use on the smaller pulley, and recommends that the larger pulley be grooved with a wider angle to a degree such that the resistance to slipping is equal in both wheels.

Mr. Miller refers to a 250-H.P. drive which has been running ten years, the large pulley being grooved  $60^{\circ}$  and the smaller  $45^{\circ}$ . This drive was designed to use a  $1\frac{1}{4}$ -in. manila rope, but the grooves were made deep

### Data of Manila Transmission Rope.

From the "Blue Book" of The American Mfg. Co., New York.

Diam. of Rope.	Square of Diam.	Approximate Weight per Ft.	Breaking Strength, Lbs.	Maximum Allowable Tension.	Length of Splice, Ft.			Smallest Diam. of Sheaves, Ins.	Maximum R.P.M.
					3 Strands.	4 Strands.	6 Strands.		
3/4	0.5625	0.20	3,950	112	6	8	...	28	760
7/8	0.7656	0.26	5,400	153	6	8	....	32	650
1	1.	0.34	7,000	200	7	10	14	36	570
1 1/8	1.2656	0.43	8,900	253	7	10	16	40	510
1 1/4	1.5625	0.53	10,900	312	7	10	16	46	460
1 3/8	1.8906	0.65	13,200	378	8	12	16	50	415
1 1/2	2.25	0.77	15,700	450	8	12	18	54	380
1 5/8	2.6406	0.90	18,500	528	8	12	18	60	344
1 3/4	3.0625	1.04	21,400	612	8	12	18	64	330
2	4.	1.36	28,000	800	9	14	20	72	290
2 1/4	5.0625	1.73	35,400	1,012	9	14	20	82	255
2 1/2	6.25	2.13	43,700	1,250	10	16	22	90	230

Weight of transmission rope =  $0.34 \times \text{diam.}^2$

Breaking strength =  $7,000 \times \text{diam.}^2$

Maximum allowable tension =  $200 \times \text{diam.}^2$

Diam. smallest practicable sheave, =  $36 \times \text{diam.}$

Velocity of rope (assumed) = 5,400 ft. per min.

enough so that a 7/8-in. rope would not bottom. In order to determine the value of the drive a common 7/8-in. rope was put in at first, and lasted six years, working under a factor of safety of only 14. He recommends, however, for continuous rope-driving a factor of safety of not less than 20.

A heavy rope-drive on the separate, or English, rope system is described and illustrated in *Power*, April, 1892. It is in use at the India Mill at Darwen, England, and is driven by a 2000-H.P. engine at 54 revs. per min. The fly-wheel is 30 ft. diameter, weighs 65 tons, and is arranged with 30 grooves for 1 3/4-in. ropes. These ropes lead off to receiving-pulleys upon the several floors, so that each floor receives its power direct from the fly-wheel. The speed of the ropes is 5089 ft. per min., and five 7-ft. receivers are used. Lambeth cotton ropes are used. (For much other information on this subject see "Rope-Driving," by J. J. Flather, John Wiley & Sons.)

**Cotton Ropes** are advantageously used as bands or cords on the smaller machine appliances; the fiber, being softer and more flexible than manila hemp, gives good results for small sheaves; but for large drives, where power transmitted is in considerable amounts, cotton rope, as compared with manila, is hardly to be considered, on account of the following disadvantages: It is less durable; it is injuriously affected by the weather, so that for exposed drives, paper-mill work, or use in water-wheel pits, it is absolutely unsatisfactory; it is difficult, if not impossible, to splice uniformly; even the best quality cotton rope is much inferior to manila in strength, the breaking strain of the highest grade being but  $4000 \times \text{diam.}^2$  as against  $7000 \times \text{diam.}^2$  for manila; while, for the transmission of equal powers, the cost of a cotton rope varies from one-third to one-half more than manila. — ("Blue Book" of the Amer. Mfg. Co.)

A different opinion is found in a paper by E. Kenyon in *Proc. Inst. Engrs. and Shipbuilders of Scotland*, 1904. He says: Evidences of the progress of cotton in the manufacture of driving-ropes are so far-reaching that its superiority may be considered as much an accepted principle in rope transmission as the law of gravitation is in science. As to the longevity of cotton ropes, 24 cotton ropes 1 3/4-in. diam. are transmitting 820 H.P. at a peripheral speed of 4396 ft. per min., from a driving pulley 28 ft. diam. All the card-room ropes in this drive have been running since 1878, a period of 26 years, without any attention whatever.

FRICION AND LUBRICATION.

**Friction** is defined by Rankine as that force which acts between two bodies at their surface of contact so as to resist their sliding on each other, and which depends on the force with which the bodies are pressed together.

**Coefficient of Friction.**—The ratio of the force required to slide a body along a horizontal plane surface to the weight of the body is called the coefficient of friction. It is equivalent to the tangent of the *angle of repose*, which is the angle of inclination to the horizontal of an inclined plane on which the body will just overcome its tendency to slide. The angle is usually denoted by  $\theta$ , and the coefficient by  $f$ .  $f = \tan \theta$ .

**Friction of Rest and of Motion.**—The force required to start a body sliding is called the friction of rest, and the force required to continue its sliding after having started is called the friction of motion.

**Rolling Friction** is the force required to roll a cylindrical or spherical body on a plane or on a curved surface. It depends on the nature of the surfaces and on the force with which they are pressed together, but is essentially different from ordinary, or sliding, friction.

**Friction of Solids.**—Rennie's experiments (1829) on friction of solids, usually unlubricated and dry, led to the following conclusions:

1. The laws of sliding friction differ with the character of the bodies rubbing together.
2. The friction of fibrous material is increased by increased extent of surface and by time of contact, and is diminished by pressure and speed.
3. With wood, metal, and stones, within the limit of abrasion, friction varies only with the pressure, and is independent of the extent of surface, time of contact, and velocity.
4. The limit of abrasion is determined by the hardness of the softer of the two rubbing parts.
5. Friction is greatest with soft and least with hard materials.
6. The friction of lubricated surfaces is determined by the nature of the lubricant rather than by that of the solids themselves.

**Friction of Rest. (Rennie.)**

Pressure, Lbs. per Square Inch.	Values of $f$ .			
	Wrought Iron on Wrought Iron.	Wrought on Cast Iron.	Steel on Cast Iron.	Brass on Cast Iron.
187	0.25	0.28	0.30	0.23
224	.27	.29	.33	.22
336	.31	.33	.35	.21
448	.38	.37	.35	.21
560	.41	.37	.36	.23
672	Abraded	.38	.40	.23
784	"	Abraded	Abraded	.23

**Law of Unlubricated Friction.**—A. M. Wellington, *Eng'g News*, April 7, 1888, states that the most important and the best determined of all the laws of unlubricated friction may be thus expressed:

The coefficient of unlubricated friction decreases materially with velocity, is very much greater at minute velocities of 0+, falls very rapidly with minute increases of such velocities, and continues to fall much less rapidly with higher velocities up to a certain varying point, following closely the laws which obtain with lubricated friction.

**Friction of Steel Tires Sliding on Steel Rails. (Westinghouse & Galton.)**

Speed, miles per hour.....	10	15	25	38	45	50
Coefficient of friction.....	0.110	.087	.080	.051	.047	.040
Adhesion, lbs. per gross ton	246	195	179	128	114	90

**Rolling Friction** is a consequence of the irregularities of form and the roughness of surface of bodies rolling one over the other. Its laws are not yet definitely established in consequence of the uncertainty which exists in experiment as to how much of the resistance is due to roughness of surface, how much to original and permanent irregularity of form, and how much to distortion under the load. (Thurston.)



**Coefficients of Rolling Friction.**—If  $R$  = resistance applied at the circumference of the wheel,  $W$  = total weight,  $r$  = radius of the wheel, and  $f$  = a coefficient,  $R = fW \div r$ .  $f$  is very variable. Coulomb gives 0.06 for wood, 0.005 for metal, where  $W$  is in pounds and  $r$  in feet. Tredgold made the value of  $f$  for iron on iron 0.002. For wagons on soft soil Morin found  $f = 0.065$ , and on hard smooth roads 0.002.

A Committee of the Society of Arts (Clark, R. T. D.) reported a loaded omnibus to exhibit a resistance on various loads as below:

Pavement.	Speed per hour.	Coefficient.	Resistance.
Granite .....	2.87 miles.	0.007	17.41 per ton.
Asphalt .....	3.56 "	0.0121	27.14 "
Wood .....	3.34 "	0.0185	41.60 "
Macadam, graveled.....	3.45 "	0.0199	44.48 "
Macadam, granite, new....	3.51 "	0.0451	101.09 "

Thurston gives the value of  $f$  for ordinary railroads, 0.003; well-laid railroad track, 0.002; best possible railroad track, 0.001.

The few experiments that have been made upon the coefficients of rolling friction, apart from axle friction, are too incomplete to serve as a basis for practical rules. (Trautwine.)

**Laws of Fluid Friction.**—For all fluids, whether liquid or gaseous, the resistance is (1) independent of the pressure between the masses in contact; (2) directly proportional to the area of rubbing-surface; (3) proportional to the square of the relative velocity at moderate and high speeds, and to the velocity nearly at low speeds; (4) independent of the nature of the surfaces of the solid against which the stream may flow, but dependent to some extent upon their degree of roughness; (5) proportional to the density of the fluid, and related in some way to its viscosity. (Thurston.)

The Friction of Lubricated Surfaces approximates that of solid friction as the journal is run dry, and that of fluid friction as it is flooded with oil.

#### Angles of Repose and Coefficients of Friction of Building Materials.

(From Rankine's Applied Mechanics.)

	$\theta$ .	$f = \tan \theta$ .	$1 \div \tan \theta$
Dry masonry and brickwork...	$31^\circ$ to $35^\circ$	0.6 to 0.7	1.67 to 1.4
Masonry and brickwork with damp mortar.....	$36\frac{1}{2}^\circ$	0.74	1.35
Timber on stone.....	$22^\circ$	about 0.4	2.5
Iron on stone.....	$35^\circ$ to $162\frac{3}{3}^\circ$	0.7 to 0.3	1.43 to 3.3
Timber on timber.....	$26\frac{1}{2}^\circ$ to $111\frac{3}{3}^\circ$	0.5 to 0.2	2 to 5
Timber on metals.....	$31^\circ$ to $111\frac{3}{3}^\circ$	0.6 to 0.2	1.67 to 5
Metals on metals.....	$14^\circ$ to $81\frac{2}{2}^\circ$	0.25 to 0.15	4 to 6.67
Masonry on dry clay.....	$27^\circ$	0.51	1.96
Masonry on moist clay.....	$18\frac{1}{4}^\circ$	0.33	3.
Earth on earth.....	$14^\circ$ to $45^\circ$	0.25 to 1.0	4 to 1
Earth on earth, dry sand, clay, and mixed earth.....	$21^\circ$ to $37^\circ$	0.38 to 0.75	2.63 to 1.33
Earth on earth, damp clay.....	$45^\circ$	1.0	1
Earth on earth, wet clay.....	$17^\circ$	0.31	3.23
Earth on earth, shingle and gravel.....	$39^\circ$ to $48^\circ$	0.81	1.23 to 0.9

#### Coefficients of Friction of Journals. (Morin.)

Material.	Unguent.	Lubrication.	
		Intermittent.	Continuous.
Cast iron on cast iron.....	Oil, lard, tallow.	0.07 to 0.08	0.03 to 0.054
	Unctuous and wet	0.14	
Cast iron on bronze.....	Oil, lard, tallow.	0.07 to 0.08	0.03 to 0.054
	Unctuous and wet	0.16	
Cast iron on lignum vitæ...	Oil, lard.	.....	0.09
Wrought iron on cast iron.	Oil, lard, tallow.	0.07 to 0.08	0.03 to 0.054
Wrought iron on bronze..			
Iron on lignum vitæ.....	Oil, lard.	0.11	
	Unctuous.	0.19	
Bronze on bronze.....	Olive oil.	0.10	
	Lard.	0.09	

Prof. Thurston says concerning the foregoing figures that much better results are probably obtained in good practice with ordinary machinery. Those here given are so modified by variations of speed, pressure, and temperature, that they cannot be taken as correct for general purposes.

**Friction of Motion.**—The following is a table of the angle of repose  $\theta$ , the coefficient of friction  $f = \tan \theta$ , and its reciprocal,  $1 \div f$ , for the materials of mechanism—condensed from the tables of General Morin (1831) and other sources, as given by Rankine:

No.	Surfaces.	$\theta$ .	$f$ .	$1 \div f$ .
1	Wood on wood, dry.....	14° to 26 1/2°	0.25 to 0.5	4 to 2
2	“ “ “ soaped.....	11 1/2° to 2°	0.2 to 0.04	5 to 25
3	Metals on oak, dry.....	26 1/2° to 31°	0.5 to 0.6	2 to 1.67
4	“ “ “ wet.....	13 1/2° to 14°	0.24 to 0.26	4.17 to 3.85
5	“ “ “ soapy.....	11 1/2°	0.2	5
6	“ “ elm, dry.....	11 1/2° to 14°	0.2 to 0.25	5 to 4
7	Hemp on oak, dry.....	28°	0.53	1.89
8	“ “ “ wet.....	18 1/2°	0.33	3
9	Leather on oak.....	15° to 19 1/2°	0.27 to 0.38	3.7 to 2.86
10	“ “ metals, dry.....	29 1/2°	0.56	1.79
11	“ “ metals, wet.....	20°	0.36	2.78
12	“ “ “ greasy..	13°	0.23	4.35
13	“ “ “ oily.....	8 1/2°	0.15	6.67
14	Metals on metals, dry.....	8 1/2° to 11°	0.15 to 0.2	6.67 to 5
15	“ “ “ wet.....	16 1/2°	0.3	3.33
16	Smooth surfaces, occasionally greased.....	4° to 4 1/2°	0.07 to 0.08	14.3 to 12.5
17	Smooth surfaces, continuously greased.....	3°	0.05	20
18	Smooth surfaces, best results	13 3/4° to 2°	0.03 to 0.036	.....
19	Bronze on lignum vitæ, constantly wet.....	3°?	0.05?	.....

**Average Coefficients of Friction.**—Journal of cast iron in bronze bearing; velocity 720 feet per minute; temperature 70° F.; intermittent feed through an oil-hole. (Thurston on Friction and Lost Work.)

Oils.	Pressures, Pounds per Square Inch.			
	8	16	32	48
Sperm, lard, neatsfoot, etc..	.159 to .250	.138 to .192	.086 to .141	.077 to .144
Olive, cotton-seed, rape, etc..	.160 to .283	.107 to .245	.101 to .168	.079 to .131
Cod and menhaden.....	.248 to .278	.124 to .167	.097 to .102	.081 to .122
Mineral lubricating-oils....	.154 to .261	.145 to .233	.086 to .178	.094 to .222

With fine steel journals running in bronze bearings and continuous lubrication, coefficients far below those above given are obtained. Thus with sperm-oil the coefficient with 50 lbs. per square inch pressure was 0.0034; with 200 lbs., 0.0051; with 300 lbs., 0.0057.

For very low pressures, as in spindles, the coefficients are much higher. Thus Mr. Woodbury found, at a temperature of 100° and a velocity of 600 feet per minute,

Pressures, lbs. per sq. in...	1	2	3	4	5
Coefficient.....	0.38	0.27	0.22	0.18	0.17

These high coefficients, however, and the great decrease in the coefficient at increased pressures are limited as a practical matter only to the smaller pressures which exist especially in spinning machinery, where the pressure is so light and the film of oil so thick that the viscosity of the oil is an important part of the total frictional resistance.

**Experiments on Friction of a Journal Lubricated by an Oil-bath** (reported by the Committee on Friction, *Proc. Inst. M. E.*, Nov., 1883) show that the absolute friction, that is, the absolute tangential force per square inch of bearing, required to resist the tendency of the brass to go round with the journal, is nearly a constant under all loads, within ordinary working limits. Most certainly it does not in-

crease in direct proportion to the load, as it should do according to the ordinary theory of solid friction. The results of these experiments seem to show that the friction of a perfectly lubricated journal follows the laws of liquid friction much more closely than those of solid friction. They show that under these circumstances the friction is nearly independent of the pressure per square inch, and that it increases with the velocity, though at a rate not nearly so rapid as the square of the velocity.

The experiments on friction at different temperatures indicate a great diminution in the friction as the temperature rises. Thus in the case of lard-oil, taking a speed of 450 r.p.m., the coefficient of friction at a temperature of 120° is only one-third of what it was at a temperature of 60°.

The journal was of steel, 4 ins. diameter and 6 ins. long, and a gun-metal brass, embracing somewhat less than half the circumference of the journal, rested on its upper side, on which the load was applied. When the bottom of the journal was immersed in oil, and the oil therefore carried under the brass by rotation of the journal, the greatest load carried with rape-oil was 573 lbs. per sq. in., and with mineral oil 625 lbs.

In experiments with ordinary lubrication, the oil being fed in at the center of the top of the brass, and a distributing groove being cut in the brass parallel to the axis of the journal, the bearing would not run cool with only 100 lbs. per sq. in., the oil being pressed out from the bearing-surface and through the oil-hole, instead of being carried in by it. On introducing the oil at the sides through two parallel grooves, the lubrication appeared to be satisfactory, but the bearing seized with 380 lbs. per sq. in.

When the oil was introduced through two oil-holes, one near each end of the brass, and each connected with a curved groove, the brass refused to take its oil or run cool, and seized with a load of only 200 lbs. per sq. in.

With an oil-pad under the journal feeding rape-oil, the bearing fairly carried 551 lbs. Mr. Tower's conclusion from these experiments is that the friction depends on the quantity and uniformity of distribution of the oil, and may be anything between the oil-bath results and seizing, according to the perfection or imperfection of the lubrication. The lubrication may be very small, giving a coefficient of  $1/100$ ; but it appeared as though it could not be diminished and the friction increased much beyond this point without imminent risk of heating and seizing. The oil-bath probably represents the most perfect lubrication possible, and the limit beyond which friction cannot be reduced by lubrication; and the experiments show that with speeds of from 100 to 200 feet per minute, by properly proportioning the bearing-surface to the load, it is possible to reduce the coefficient of friction to as low as  $1/1000$ . A coefficient of  $1/1500$  is easily attainable, and probably is frequently attained, in ordinary engine-bearings in which the direction of the force is rapidly alternating and the oil given an opportunity to get between the surfaces, while the duration of the force in one direction is not sufficient to allow time for the oil film to be squeezed out.

Observations on the behavior of the apparatus gave reason to believe that with perfect lubrication the speed of minimum friction was from 100 to 150 feet per minute, and that this speed of minimum friction tends to be higher with an increase of load, and also with less perfect lubrication. By the speed of minimum friction is meant that speed in approaching which from rest the friction diminishes, and above which the friction increases.

**Coefficients of Friction of Motion and of Rest of a Journal.** — A cast-iron journal in steel boxes, tested by Prof. Thurston at a speed of rubbing of 150 feet per minute, with lard and with sperm oil, gave the following:

Press. per sq. in., lbs.	50	100	250	500	750	1000
Coeff., with sperm...	0.013	0.008	0.005	0.004	0.0043	0.009
Coeff., with lard....	0.02	0.0137	0.0085	0.0053	0.0066	0.125

The coefficients at starting were:

With sperm.....	0.07	0.135	0.14	0.15	0.185	0.18
With lard.....	0.07	0.11	0.11	0.10	0.12	0.12

The coefficient at a speed of 150 feet per minute decreases with increase of pressure until 500 lbs. per sq. in. is reached; above this it increases. The coefficient at rest or at starting increases with the pressure throughout the range of the tests.





2. The coefficient and amount of friction, pressure being the same, are independent of the areas in contact.

3. The coefficient of friction is independent of velocity, although static friction (friction of rest) is greater than the friction of motion.

*Eng'g News*, April 7, 1888, comments on these "laws" as follows: From 1831 till about 1876 there was no attempt worth speaking of to enlarge our knowledge of the laws of friction, which during all that period was assumed to be complete, although it was really worse than nothing, since it was for the most part wholly false. In the year first mentioned Morin began a series of experiments which extended over two or three years, and which resulted in the enunciation of these three "fundamental laws of friction," no one of which is even approximately true.

For fifty years these laws were accepted as axiomatic, and were quoted as such without question in every scientific work published during that whole period. Now that they are so thoroughly discredited it has been attempted to explain away their defects on the ground that they cover only a very limited range of pressures, areas, velocities, etc., and that Morin himself only announced them as true within the range of his conditions. It is now clearly established that there are no limits or conditions within which any one of them even approximates to exactitude, and that there are many conditions under which they lead to the wildest kind of error, while many of the constants were as inaccurate as the laws. For example, in Morin's "Table of Coefficients of Moving Friction of Smooth Plane Surfaces, perfectly lubricated," which may be found in hundreds of text-books now in use, the coefficient of wrought iron on brass is given as 0.075 to 0.103, which would make the rolling friction of railway trains 15 to 20 lbs. per ton instead of the 3 to 6 lbs. which it actually is.

General Morin, in a letter to the Secretary of the Institution of Mechanical Engineers, dated March 15, 1879, writes as follows concerning his experiments on friction made more than forty years before: "The results furnished by my experiments as to the relations between pressure, surface, and speed on the one hand, and sliding friction on the other, have always been regarded by myself, not as mathematical laws, but as close approximations to the truth, within the limits of the data of the experiments themselves. The same holds, in my opinion, for many other laws of practical mechanics, such as those of rolling resistance, fluid resistance, etc."

Prof. J. E. Denton (*Stevens Indicator*, July, 1890) says: It has been generally assumed that friction between lubricated surfaces follows the simple law that the amount of the friction is some fixed fraction of the pressure between the surfaces, such fraction being independent of the intensity of the pressure per square inch and the velocity of rubbing, between certain limits of practice, and that the fixed fraction referred to is represented by the coefficients of friction given by the experiments of Morin or obtained from experimental data which represent conditions of practical lubrication, such as those given in Webber's *Manual of Power*.

By the experiments of Thurston, Woodbury, Tower, etc., however, it appears that the friction between lubricated metallic surfaces, such as machine bearings, is not directly proportional to the pressure, is not independent of the speed, and that the coefficients of Morin and Webber are about tenfold too great for modern journals.

Prof. Denton offers an explanation of this apparent contradiction of authorities by showing, with laboratory testing-machine data, that Morin's laws hold for bearings lubricated by a restricted feed of lubricant, such as is afforded by the oil-cups common to machinery; whereas the modern experiments have been made with a surplus feed or superabundance of lubricant, such as is provided only in railroad-car journals, and a few special cases of practice.

That the low coefficients of friction obtained under the latter conditions are realized in the case of car-journals, is proved by the fact that the temperature of car-boxes remains at 100° at high velocities; and experiment shows that this temperature is consistent only with a coefficient of friction of a fraction of one per cent. Deductions from experiments on train resistance also indicate the same low degree of friction. But these low coefficients do not account for the internal friction of steam-engines as well as do the coefficients of Morin and Webber.

In *American Machinist*, Oct. 23, 1890, Prof. Denton says: Morin's measurements of friction of lubricated journals did not extend to light pressures. They apply only to the conditions of general shafting and engine work.

He clearly understood that there was a frictional resistance, due solely to the viscosity of the oil, and that therefore, for very light pressures, the laws which he enunciated did not prevail.

He applied his dynamometers to ordinary shaft-journals without special preparation of the rubbing-surfaces, and without resorting to artificial methods of supplying the oil.

Later experimenters have with few exceptions devoted themselves exclusively to the measurement of resistance practically due to viscosity alone. They have eliminated the resistance to which Morin confined his measurements, namely, the friction due to such contacts of the rubbing-surfaces as prevail with a very thin film of lubricant between comparatively rough surfaces.

Prof. Denton also says (*Trans. A. S. M. E.*, x, 518): "I do not believe there is a particle of proof in any investigation of friction ever made, that Morin's laws do not hold for ordinary practical oil-cups or restricted rates of feed."

**Laws of Friction of Well-lubricated Journals.** — John Goodman (*Trans. Inst. C. E.*, 1886, *Eng'g News*, April 7 and 14, 1888), reviewing the results obtained from the testing-machines of Thurston, Tower, and Stroudley, arrives at the following laws:

LAWS OF FRICTION: WELL-LUBRICATED SURFACES.  
(Oil-bath.)

1. The coefficient of friction with the surfaces efficiently lubricated is from  $\frac{1}{8}$  to  $\frac{1}{10}$  that for dry or scantily lubricated surfaces.

2. The coefficient of friction for moderate pressures and speeds varies approximately inversely as the normal pressure; the frictional resistance varies as the area in contact, the normal pressure remaining constant.

3. At very low journal speeds the coefficient of friction is abnormally high; but as the speed of sliding increases from about 10 to 100 ft. per min., the friction diminishes, and again rises when that speed is exceeded, varying approximately as the square root of the speed.

4. The coefficient of friction varies approximately inversely as the temperature, within certain limits, namely, just before abrasion takes place.

The evidence upon which these laws are based is taken from various modern experiments. That relating to Law 1 is derived from the "First Report on Friction Experiments," by Mr. Beauchamp Tower.

Method of Lubrication.	Coefficient of Friction.	Comparative Friction.
Oil-bath.....	0.00139	1.00
Siphon lubricator.....	0.0098	7.06
Pad under journal.....	0.0090	6.48

With a load of 293 lbs. per sq. in. and a journal speed of 314 ft. per min. Mr. Tower found the coefficient of friction to be 0.0016 with an oil-bath, and 0.0097, or six times as much, with a pad. The very low coefficients obtained by Mr. Tower will be accounted for by Law 2, as he found that the frictional resistance per square inch under varying loads is nearly constant, as below:

Load in lbs. per sq. in.	529	468	415	363	310	258	205	153	100
Frictional resist. per sq. in.	} 0.416 0.514 0.498 0.472 0.464 0.438 0.43 0.458 0.45								

The frictional resistance per square inch is the product of the coefficient of friction into the load per square inch on horizontal sections of the brass. Hence, if this product be a constant, the one factor must vary inversely as the other, or a high load will give a low coefficient, and *vice versa*.

For ordinary lubrication, the coefficient is more constant under varying loads: the frictional resistance then varies directly as the load, as shown by Mr. Tower in Table VIII of his report (*Proc. Inst. M. E.*, 1883).



With respect to Law 3, A. M. Wellington (*Trans. A. S. C. E.*, 1884), in experiments on journals revolving at very low velocities, found that the friction was then very great, and nearly constant under varying conditions of the lubrication, load, and temperature. But as the speed increased the friction fell slowly and regularly, and again returned to the original amount when the velocity was reduced to the same rate. This is shown in the following table:

Speed, feet per minute:  
 0 + 2.16 3.33 4.86 8.82 21.42 35.37 53.01 89.28 106.02  
 Coefficient of friction:  
 0.118 0.094 0.070 0.069 0.055 0.047 0.040 0.035 0.030 0.026

It was also found by Prof. Kimball that when the journal velocity was increased from 6 to 110 ft. per min., the friction was reduced 70%; in another case the friction was reduced 67% when the velocity was increased from 1 to 100 ft. per min.; but after that point was reached the coefficient varied approximately with the square root of the velocity.

The following results were obtained by Mr. Tower:

Feet per minute	209	262	314	366	419	471	Nominal Load per Sq. In.
Coeff. of friction.....	0.0010	0.0012	0.0013	0.0014	0.0015	0.0017	520 lbs.
“ “ .....	.0013	.0014	.0015	.0017	.0018	.002	468 lbs.
“ “ .....	.0014	.0015	.0017	.0019	.0021	.0024	415 lbs.

The variation of friction with temperature is approximately in the inverse ratio, Law 4. Take, for example, Mr. Tower's results, at 262 ft. per minute:

Temp. F.	110°	100°	90°	80°	70°	60°
Observed.....	0.0044	0.0051	0.006	0.0073	0.0092	0.0119
Calculated.....	0.00451	0.00518	0.00608	0.00733	0.00964	0.01252

This law does not hold good for pad or siphon lubrication, as then the coefficient of friction diminishes more rapidly for given increments of temperature, but on a gradually decreasing scale, until the normal temperature has been reached; this normal temperature increases directly as the load per sq. in. This is shown in the following table taken from Mr. Stroudley's experiments with a pad of rape-oil:

Temp. F.....	105°	110°	115°	120°	125°	130°	135°	140°	145°
Coefficient.....	0.022	0.0180	0.0160	0.0140	0.0125	0.0115	0.0110	0.0106	0.0102
Decrease of coeff. ....	.....	0.0040	0.0020	0.0020	0.0015	0.0010	0.0005	0.0004	0.0002

In the Galton-Westinghouse experiments it was found that with velocities below 100 ft. per min., and with low pressures, the frictional resistance varied directly as the normal pressure; but when a velocity of 100 ft. per min. was exceeded, the coefficient of friction greatly diminished; from the same experiments Prot. Kennedy found that the coefficient of friction for high pressures was sensibly less than for low.

**Allowable Pressures on Bearing-surfaces.** (*Proc. Inst. M. E.*, May, 1888.) — The Committee on Friction experimented with a steel ring of rectangular section, pressed between two cast-iron disks, the annular bearing-surfaces of which were covered with gun-metal, and were 12 in. inside diameter and 14 in. outside. The two disks were rotated together, and the steel ring was prevented from rotating by means of a lever, the holding force of which was measured. When oiled through grooves cut in each face of the ring and tested at from 50 to 130 revs. per min., it was found that a pressure of 75 lbs. per sq. in. of bearing-surface was as much as it would bear safely at the highest speed without seizing, although it carried 90 lbs. per sq. in. at the lowest speed. The coefficient of friction is also much higher than for a cylindrical bearing, and the friction follows the law of the friction of solids much more nearly than that of liquids. This is doubtless due to the much less perfect lubrication applicable to this form of bearing compared with a cylindrical one. The coefficient of friction appears to be about the same with the same load at all speeds, or, in other words, to be independent of the speed; but it seems to diminish somewhat as the load is increased, and may be stated approximately as 1/20 at 15 lbs. per sq. in., diminishing to 1/30 at 75 lbs. per sq. in.

The high coefficients of friction are explained by the difficulty of lubricating a collar-bearing. It is similar to the slide-block of an engine:

which can carry only about one-tenth the load per sq. in. that can be carried by the crank-pins.

In experiments on cylindrical journals it has been shown that when a cylindrical journal was lubricated from the side on which the pressure bore, 100 lbs. per sq. in. was the limit of pressure that it would carry; but when it came to be lubricated on the lower side and was allowed to drag the oil in with it, 600 lbs. per sq. in. was reached with impunity; and if the 600 lbs. per sq. in., which was reckoned upon the full diameter of the bearing, came to be reckoned on the sixth part of the circle that was taking the greater proportion of the load, it followed that the pressure upon that part of the circle amounted to about 1200 lbs. per sq. in.

In connection with these experiments Mr. Wicksteed states that in drilling-machines the pressure on the collars is frequently as high as 336 lbs. per sq. in., but the speed of rubbing in this case is lower than it was in any of the experiments of the Research Committee. In machines working very slowly and intermittently, as in testing-machines, very much higher pressures are admissible. Prof. Thurston (*Friction and Lost Work*, p. 240) says 7000 to 9000 lbs. pressure per square inch is reached on the slow working and rarely moved pivots of swing bridges.

Mr. Adamson mentions the case of a heavy upright shaft carried upon a small footstep-bearing, where a weight of at least 20 tons was carried on a shaft of 5 in. diameter, or, say, 20 sq. in. area, giving a pressure of 1 ton per sq. in. The speed was 190 to 200 revs. per min. It was necessary to force the oil under the bearing by means of a pump. For heavy horizontal shafts, such as a fly-wheel shaft, carrying 100 tons on two journals, his practice for getting oil into the bearings was to flatten the journal along one side throughout its whole length to the extent of about an eighth of an inch in width for each inch in diameter up to 8 in. diameter; above that size rather less flat in proportion to the diameter. At first sight it appeared alarming to get a continuous flat place coming round in every revolution of a heavily loaded shaft; yet it carried the oil effectually into the bearing, which ran much better in consequence than a truly cylindrical journal without a flat side.

In thrust-bearings on torpedo-boats Mr. Thornycroft allows a pressure of never more than 50 lbs. per sq. in.

Mr. Tower says (*Proc. Inst. M. E.*, Jan., 1884): In eccentric-pins of punching and shearing machines very high pressures are sometimes used without seizing. In addition to the alternation in the direction, the pressure is applied for only a very short space of time in these machines, so that the oil has no time to be squeezed out.

In the discussion on Mr. Tower's paper (*Proc. Inst. M. E.*, 1885) it was stated that it is well known from practical experience that with a constant load on an ordinary journal it is difficult and almost impossible to have more than 200 lbs. per square inch, otherwise the bearing would get hot and the oil go out of it; but when the motion was reciprocating, so that the load was alternately relieved from the journal, as with crank-pins and similar journals, much higher loads might be applied than even 700 or 800 lbs. per square inch.

Mr. Goodman (*Proc. Inst. C. E.*, 1886) found that the total frictional resistance is materially reduced by diminishing the width of the brass.

The lubrication is most efficient in reducing the friction when the brass subtends an angle of from 120° to 60°. The film is probably at its best between the angles 80° and 110°.

In the case of a brass of a railway axle-bearing where an oil-groove is cut along its crown and an oil-hole is drilled through the top of the brass into it, the wear is invariably on the off side, which is probably due to the oil escaping as soon as it reaches the crown of the brass, and so leaving the off side almost dry, where the wear consequently ensues.

In railway axles the brass wears always on the forward side. The same observation has been made in marine-engine journals, which always wear in exactly the reverse way to what might be expected. Mr. Stroudley thinks this peculiarity is due to a film of lubricant being drawn in from the under side of the journal to the aft part of the brass, which effectually lubricates and prevents wear on that side; and that when the lubricant reaches the forward side of the brass it is so attenuated down to a wedge shape that there is insufficient lubrication, and greater wear consequently follows.

C. J. Field (*Power*, Feb., 1893) says: One of the most vital points of an engine for electrical service is that of main bearings. They should have a surface velocity of not exceeding 350 feet per minute, with a mean bearing-pressure per square inch of projected area of journal of not more than 80 lbs. This is considerably within the safe limit of cool performance and easy operation. If the bearings are designed in this way, it would admit the use of grease on all the main wearing-surface, which in a large type of engines for this class of work we think advisable.

**Oil-pressure in a Bearing.** — Mr. Beauchamp Tower (*Proc. Inst. M. E.*, Jan., 1885) made experiments with a brass bearing 4 ins. diameter by 6 ins. long, to determine the pressure of the oil between the brass and the journal. The bearing was half immersed in oil, and had a total load of 8008 lbs. upon it. The journal rotated 150 r.p.m. The pressure of the oil was determined by drilling small holes in the bearing at different points and connecting them by tubes to a Bourdon gauge. It was found that the pressure varied from 310 to 625 lbs. per sq. in., the greatest pressure being a little to the "off" side of the center line of the top of the bearing, in the direction of motion of the journal. The sum of the upward force exerted by these pressures for the whole lubricated area was nearly equal to the total pressure on the bearing. The speed was reduced from 150 to 20 r.p.m., but the oil-pressure remained the same, showing that the brass was as completely oil-borne at the lower speed as at the higher. The following was the observed friction at the lower speed:

Nominal load, lbs. per sq. in....	443	333	211	89
Coefficient of friction.....	0.00132	0.00168	0.00247	0.0044

The nominal load per square inch is the total load divided by the product of the diameter and length of the journal. At the low speed of 20 r.p.m. it was increased to 676 lbs. per sq. in. without any signs of heating or seizing.

**Friction of Car-journal Brasses.** (J. E. Denton, *Trans. A. S. M. E.*, xii, 405.) — A new brass dressed with an emery-wheel, loaded with 5000 lbs., may have an actual bearing-surface on the journal, as shown by the polish of a portion of the surface, of only 1 square inch. With this pressure of 5000 lbs. per sq. in., the coefficient of friction may be 6%, and the brass may be overheated, scarred and cut, but, on the contrary, it may wear down evenly to a smooth bearing, giving a highly polished area of contact of 3 sq. ins., or more, inside of two hours of running, gradually decreasing the pressure per square inch of contact, and a coefficient of friction of less than 0.5%. A reciprocating motion in the direction of the axis is of importance in reducing the friction. With such polished surfaces any oil will lubricate, and the coefficient of friction then depends on the viscosity of the oil. With a pressure of 1000 lbs. per sq. in., revolutions from 170 to 320 per min., and temperatures of 75° to 113° F., with both sperm and paraffine oils, a coefficient of as low as 0.11% has been obtained, the oil being fed continuously by a pad.

**Experiments on Overheating of Bearings. — Hot Boxes.** (Denton.) — Tests with car brasses loaded from 1100 to 4500 lbs. per sq. in. gave 7 cases of overheating out of 32 trials. The tests show how purely a matter of chance is the overheating, as a brass which ran hot at 5000 lbs. load on one day would run cool on a later date at the same or higher pressure. The explanation of this apparently arbitrary difference of behavior is that the accidental variations of the smoothness of the surfaces, almost infinitesimal in their magnitude, cause variations of friction which are always tending to produce overheating, and it is solely a matter of chance when these tendencies preponderate over the lubricating influence of the oil. There is no appreciable advantage shown by sperm-oil, when there is no tendency to overheat — that is, paraffine can lubricate under the highest pressures which occur, as well as sperm, when the surfaces are within the conditions affording the minimum coefficients of friction.

Sperm and other oils of high heat-resisting qualities, like vegetable oil and petroleum cylinder stocks, differ from the more volatile lubricants, like paraffine, only in their ability to reduce the chances of the continual accidental infinitesimal abrasion producing overheating.

The effect of emery or other gritty substance in reducing overheating of a bearing is thus explained:



The effect of the emery upon the surfaces of the bearings is to cover the latter with a series of parallel grooves, and apparently after such grooves are made the presence of the emery does not practically increase the friction over its amount when pure oil only is between the surfaces. The infinite number of grooves constitute a very perfect means of insuring a uniform oil supply at every point of the bearings. As long as grooves in the journal match with those in the brasses the friction appears to amount to only about 10% to 15% of the pressure. But if a smooth journal is placed between a set of brasses which are grooved, and pressure be applied, the journal crushes the grooves and becomes brazed or coated with brass, and then the coefficient of friction becomes upward of 40%. If then emery is applied, the friction is made very much less by its presence, because the grooves are made to match each other, and a uniform oil supply prevails at every point of the bearings, whereas before the application of the emery many spots of the bearing receive no oil between them.

**Moment of Friction and Work of Friction of Sliding-surfaces, etc.**

	Moment of Friction, inch-lbs.	Energy lost by Friction in ft.-lbs. per min.
Flat surfaces.....	.....	$fWS$
Shafts and journals.....	$\frac{1}{2}fWd$	$0.2618 fWdn$
Flat pivots.....	$\frac{2}{3}fWr$	$0.349 fWrn$
Collar-bearing.....	$\frac{2}{3}fW \frac{r_2^3 - r_1^3}{r_2^2 - r_1^2}$	$0.349 fWn \frac{r_2^3 - r_1^3}{r_2^2 - r_1^2}$
Conical pivot.....	$\frac{2}{3}fWr \operatorname{cosec} a$	$0.349 fWrn \operatorname{cosec} a$
Conical journal.....	$\frac{2}{3}fWr \sec a$	$0.349 fWrn \sec a$
Truncated-cone pivot.....	$\frac{2}{3}fW \frac{r_2^3 - r_1^3}{r_2 \sin a}$	$0.349 fWn \frac{r_2^3 - r_1^3}{r_2 \sin a}$
Hemispherical pivot.....	$fWr$	$0.5236 fWrn$
Tractrix, or Schiele's "anti-friction" pivot.....	$fWr$	$0.5236 fWrn$

In the above  $f$  = coefficient of friction;  
 $W$  = weight on journal or pivot in pounds;  
 $r$  = radius,  $d$  = diameter, in inches;  
 $S$  = space in feet through which sliding takes place;  
 $r_2$  = outer radius,  $r_1$  = inner radius;  
 $n$  = number of revolutions per minute;  
 $a$  = the half-angle of the cone, i.e., the angle of the slope with the axis.

To obtain the horse-power, divide the quantities in the last column by 33,000. Horse-power absorbed by friction of a shaft =  $\frac{fWdn}{126,050}$ .

The formula for energy lost by shafts and journals is approximately true for loosely fitted bearings. Prof. Thurston shows that the correct formula varies according to the character of fit of the bearing; thus for loosely fitted journals, if  $U$  = the energy lost,

$$U = \frac{2f\pi r}{\sqrt{1+f^2}} Wn \text{ inch-pounds} = \frac{0.2618 fWdn}{\sqrt{1+f^2}} \text{ foot-lbs.}$$

For perfectly fitted journals  $U = 2.54 f\pi rWn$  inch-lbs. =  $0.3325 fWdn$  ft.-lbs.

For a bearing in which the journal is so grasped as to give a uniform pressure throughout,  $U = f\pi^2 rWn$  inch-lbs. =  $0.4112 fWdn$  ft.-lbs.

Resistance of railway trains and wagons due to friction of trains:

$$\text{Pull on draw-bar} = f \times 2240 \div R \text{ pounds per gross ton,}$$

in which  $R$  is the ratio of the radius of the wheel to the radius of journal.

A cylindrical journal, perfectly fitted into a bearing, and carrying a total load, distributes the pressure due to this load unequally on the bearing, the maximum pressure being at the extremity of the vertical radius, while at the extremities of the horizontal diameter the pressure is zero. At any point of the bearing-surface at the extremity of a radius which makes an angle  $\theta$  with the vertical radius the normal pressure is proportional to  $\cos \theta$ . If  $p$  = normal pressure on a unit of surface.

$w$  = total load on a unit of length of the journal, and  $r$  = radius of journal,  
 $w \cos \theta = 1.57 rp$ ,  $p = w \cos \theta \div 1.57 r$ .

**Tests of Large Shaft Bearings** are reported by Albert Kingsbury in *Trans. A. S. M. E.*, 1905. A horizontal shaft was supported in two bearings 9 × 30 ins., and a third bearing 15 × 40 ins., midway between the other two, was pressed upwards against the shaft by a weighed lever, so that it was subjected to a pressure of 25 to 50 tons. The journals were flooded with oil from a supply tank. The shaft was driven by an electric motor, and the friction H.P. was determined by measuring the current supplied. Following are the principal results:

Load, tons*	25	25	25	25	25	33.6	42.3	47	47	50.5
Load per sq. in.*	83	83	83	83	83	112	141	157	157	168
Speed, r.p.m.	309	506	180	179	301	454	480	946	1243	1286
Speed, ft. per min.*	1215	1990	708	704	1180	1785	1890	3720	4900	5050
Friction H.P.†	12.6	21.7	6.43	5.12	10.1	16	17.9	41.9	47.8	52.3
Coeff. of friction†	.0045	.0048	.0040	.0037	.0037	.0029	.0024	.0025	.0022	.0022

\* On the large bearing.

† Three bearings.

The last three tests were with paraffin oil; the others with heavy machine oil.

**Clearance between Journal and Bearing.** — John W. Upp, in *Trans. A. S. M. E.*, 1905 gives a table showing the diameter of bore of horizontal and vertical bearings according to the practice of one of the leading builders of electrical machinery. The maximum diameter of the journal is the same as its nominal diameter, with an allowable variation below maximum of 0.0005 in. up to 3 in. diam., 0.001 in. from 3½ to 9 in., and 0.0015 in. from 10 to 24 in. The maximum bore of a horizontal bearing is larger than the diam. of the journal by from 0.002 in. for a ½-in. journal to 0.009 for 6 in., for journals 7 to 15 in. it is 0.004 + 0.001 × diam., and for 16 to 24 in. it is uniformly 0.02 in. For vertical journals the clearance is less by from 0.001 to 0.004 in. according to the diameter. The allowable variation above the minimum bore is from 0.001 to 0.005.

**Allowable Pressures on Bearings.** — J. T. Nicholson, in a paper read before the Manchester Assoc. of Engrs. (*Am. Mach.*, Jan. 16, 1908, *Eng. Digest*, Feb., 1908), as a result of a theoretical study of the lubrication of bearings and of their emission of heat, obtains the formula  $p = P/ld = 40 (dN)^{1/4}$ , in which  $p$  = allowable pressure per sq. in. of projected area,  $P$  = total pressure,  $l$  = length and  $d$  = diam. of journal,  $N$  = revs. per min. It appears from this formula that the greater the speed the greater the allowable pressure per sq. in., so that for a 1-in. journal the allowable pressure per sq. in. is 126 lbs. at 100 r.p.m. and 189 lbs. at 500 r.p.m., and for a 5-in. journal 189 lbs. at 100 and 283 lbs. at 500 r.p.m. W. H. Scott (*Eng. Digest*, Feb., 1908) says this is contrary to the teaching of practical experience, and therefore the formula is inaccurate. Mr. Scott, from a study of the experiments of Tower, Lasche, and Stribeck, derives the following formulæ for the several conditions named:

- For main bearings of double-acting vertical engines.  $p = 750 D^{1/4}/N^{1/4}$
  - “ “ “ “ “ “ “ horizontal “ .  $p = 660 D^{1/12}/N^{1/4}$
  - “ “ “ “ “ “ “ single-acting four-cycle gas engines . . . . .  $p = 1350 D^{1/12}/N^{1/4}$
  - For crank pins of vert. and hor. double-acting engines.  $p = 1560 D^{1/4}/N^{1/4}$
  - “ “ “ “ “ “ “ single-acting four-cycle gas engines.  $p = 3000 D^{1/4}/N^{1/4}$
  - For dead loads with ordinary lubrication . . . . .  $p = 400 N^{-1/5}$
  - “ “ “ “ “ “ “ forced “ . . . . .  $p = 1600 N^{-1/4}$
- $p$  = allowable pressure in lbs. per sq. in. of projected area;  $D$  = diam. in ins.;  $N$  = revs. per min.

F. W. Taylor (*Trans. A. S. M. E.*, 1905), as the result of an investigation of line shaft and mill bearings that were running near the limit of durability and heating yet not dangerously heating, gives the formula  $PV = 400$ .  $P$  = pressure in lbs. per sq. in. of projected area,  $V$  = velocity of circumference of bearing in ft. per sec.

The formula is applicable to bearings in ordinary shop or mill use on shafting which is intended to run with the care and attention which such bearings usually receive, and gives the maximum or most severe duty to which it is safe to subject ordinary *chain or oiled* ball and socket bearings which are *babbitted*. It is not safe for ordinary shafting to use *cast-iron boxes*, with either sight feed, wick feed, or grease-cup oiling, under as severe conditions as  $P \times V = 200$ .

Archbutt and Deeley's "Lubrication and Lubricants" gives the following allowable pressures in lbs. per sq. in. of projected area of bearings.

Crank-pin of shearing and punching machine, hard steel, intermittent load bearing.....	3000
Bronze crosshead neck journals.....	1200
Crank pins, large slow engine.....	800-900
Crank pins, marine engines.....	400-500
Main crankshaft bearing, fast marine.....	400
Same, slow marine.....	600
Railway coach journals.....	300-400
Flywheel shaft journals.....	150-200
Small engine crank pin.....	150-200
Small slide block, marine engine.....	100
Stationary engine slide blocks.....	25-125
Same, usual case.....	30- 60
Propeller thrust bearings.....	50- 70
Shafts in cast-iron steps, high speed.....	15

**Bearing Pressures for Heavy Intermittent Loads.** (Oberlin Smith, *Trans. A. S. M. E.*, 1905.) — In a punching press of about 84 tons capacity, the pressure upon the front journal of the main shaft is about 2400 lbs. per sq. in. of projected area. Upon the eccentric the pressure against the pitman driving the ram is some 7000 lbs. per sq. in. — both surfaces being of cast iron, and sometimes running at a surface speed of 140 feet per minute. Such machines run year in and year out with but little trouble in the way of heating or "cutting." An instance of excessive pressure may be cited in the case of a Ferracute toggle press, where the whole ram pressure of 400 tons is brought to bear upon hardened steel toggle-pins, running in cast iron or bronze bearings, 3 in. in diam. by nearly 14 in. long. These run habitually, for maximum work, under a load of 20,000 lbs. per sq. in.

**Bearings for Very High Rotative Speeds.** (*Proc. Inst. M. E.*, Oct., 1888, p. 482.) — In the Parsons steam-turbine, which has a speed as high as 18,000 rev. per min., as it is impossible to secure absolute accuracy of balance, the bearings are of special construction so as to allow of a certain very small amount of lateral freedom. For this purpose the bearing is surrounded by two sets of steel washers  $\frac{1}{16}$  in. thick and of different diameters, the larger fitting close in the casing and about  $\frac{1}{32}$  in. clear of the bearing, and the smaller fitting close on the bearing and about  $\frac{1}{32}$  in. clear of the casing. These are arranged alternately, and are pressed together by a spiral spring. Consequently any lateral movement of the bearing causes them to slide mutually against one another, and by their friction to check or damp any vibrations that may be set up in the spindle. The tendency of the spindle is then to rotate about its axis of mass, and the bearings are thereby relieved from excessive pressure, and the machine from undue vibration. The allowing of the turbine itself to find its own center of gyration is a well-known device in other branches of mechanics: as in the instance of the centrifugal hydro-extractor, where a mass very much out of balance is allowed to find its own center of gyration; the faster it runs the more steadily does it revolve and the less is the vibration. Another illustration is to be found in the spindles of spinning machinery which run at about 10,000 or 11,000 revs. per min.: although of very small dimensions, the outside diameter of the largest portion or driving whorl being perhaps not more than  $1\frac{1}{4}$  in., it is found impracticable to run them at that speed in what might be called a hard-and-fast bearing. They are therefore run with some elastic substance



surrounding the bearing, such as steel springs, hemp, or cork. Any elastic substance is sufficient to absorb the vibration, and permit of absolutely steady running.

**Bearing Pressures in Shafts of Parsons Turbines.**—The product of the bearing pressure in lb. per sq. in. and the peripheral velocity in ft. per sec. is generally about 2500 (*Proc., Inst. Elect. Engrs.*, June, 1905).

**Thrust Bearings in Marine Practice.** (G. W. Dickie, *Trans. A. S. M. E.*, 1905.)—The approximate pressure on a thrust bearing of a propeller shaft assuming two thirds of the indicated horse-power to be effective

on the propeller is  $P = \text{I.H.P.} \times \frac{2 \times 60 \times 33000}{S \times 3 \times 6080} = \frac{\text{I.H.P.}}{S} \times 217.1$ , in

which  $S$  = speed of ship in knots per hour,  $P$  = total thrust in lbs. The following are data of water-cooled bearings which have given satisfactory service:

Speed in knots.....	22	22 1/2	28	21
Thrust-ring surface, horse-shoe type, sq. ins.....	1188	891	581	2268
Horse-power, one engine, I.H.P. ....	11,500	6,800	4,200	15,000
Indicated pressure on bearing, lbs.,...	112,700	89,000	33,600	154,000
Pressure per sq. in. of surface, lbs. ....	95	100	58	68.1
Mean speed of bearing surfaces, ft. per min.....	642	610	827	504

**Bearings for Locomotives.** (G. M. Basford, *Trans., A. S. M. E.*, 1905.)—Bearing areas for locomotive journals are determined chiefly by the possibilities of lubrication. On driving journals the following figures of pressure in lbs. per sq. in. of projected area give good service: passenger, 190; freight, 200; switching, 220 lbs. Crank pins may be loaded from 1500 to 1700 lbs.; wrist pins to 4000 lbs. per sq. in. Car and tender bearings are usually loaded from 300 to 325 lbs. per sq. in.

**Bearings of Corliss Engines.** (P. H. Been, *Trans. A. S. M. E.*, 1905.)—In the practice of one of the largest builders the greatest pressure allowed per sq. in. of projected area for all shafts is 140 lbs. On most engines the pressure per sq. in. multiplied by the velocity of the bearing surface in ft. per sec. lies between 1000 and 1300.

Edwin Reynolds says that a main engine bearing to be safe against undue heating should be of such a size that the product of the square root of the speed of rubbing-surface in feet per second multiplied by the pounds per square inch of projected area, should not exceed 375 for a horizontal engine, or 500 for a vertical engine when the shaft is lifted at every revolution. Locomotive driving boxes in some cases give the product as high as 585, but this is accounted for by the cooling action of the air. (*Am. Mach.*, Sept. 17, 1903.)

**Temperature of Engine Bearings.** (A. M. Mattice, *Trans. A. S. M. E.*, 1905.)—An examination of the temperature of bearings of a large number of engines of various makes showed more above 135° F. than below that figure. Many bearings were running with a temperature over 150°, and in one case at 180°, and in all of these cases the bearings were giving no trouble.

### PIVOT-BEARINGS.

**The Schiele Curve.**—W. H. Harrison (*Am. Mach.*, 1891) says the Schiele curve is not as good a form for a bearing as the segment of a sphere. He says: A mill-stone weighing a ton frequently bears its whole weight upon the flat end of a hard-steel pivot 1 1/8 in. diam., or 1 sq. in. area of bearing; but to carry a weight of 3000 lbs. he advises an end bearing about 4 ins. diam., made in the form of a segment of a sphere about 1/2 in. in height. The die or fixed bearing should be dished to fit the pivot. This form gives a chance for the bearing to adjust itself, which it does not have when made flat, or when made with the Schiele curve. If a side bearing is necessary it can be arranged farther up the shaft. The pivot and die should be of steel, hardened; cross-gutters should be in the die to allow oil to flow, and a central oil-hole should be made in the shaft.

The advantage claimed for the Schiele bearing is that the pressure is uniformly distributed over its surface, and that it therefore wears uniformly. Wilfred Lewis (*Am. Mach.*, April 19, 1894) says that its merits

as a thrust-bearing have been vastly overestimated; that the term "anti-friction" applied to it is a misnomer, since its friction is greater than that of a flat step or collar of the same diameter. He advises that flat thrust-bearings should always be annular in form, having an inside diameter one-half of the external diameter.

**Friction of a Flat Pivot-bearing.** — The Research Committee on Friction (*Proc. Inst. M. E.*, 1891) experimented on a step-bearing, flat-tended, 3 in. diam., the oil being forced into the bearing through a hole in its center and distributed through two radial grooves, insuring thorough lubrication. The step was of steel and the bearing of manganese-bronze.

At revolutions per min.	50	128	194	290	353
The coefficient of friction } varied between	0.0181	0.0053	0.0051	0.0044	0.0053
	and 0.0221	0.0113	0.0102	0.0178	0.0167

With a white-metal bearing at 128 revs. the coefficient of friction was a little larger than with the manganese-bronze. At the higher speeds the coefficient of friction was less, owing to the more perfect lubrication, as shown by the more rapid circulation of the oil. At 128 revs. the bronze-bearing heated and seized on one occasion with a load of 260 lbs., and on another occasion with 300 lbs. per sq. in. The white-metal bearing under similar conditions heated and seized with a load of 240 lbs. per sq. in. The steel footstep on manganese-bronze was afterwards tried, lubricating with three and with four radial grooves: but the friction was from one and a half times to twice as great as with only the two grooves.

**Mercury-bath Pivot.** — A nearly frictionless step-bearing may be obtained by floating the bearing with its superincumbent weight upon mercury. Such an apparatus is used in the lighthouses of La Heve, Havre. It is thus described in *Eng'g*, July 14, 1893, p. 41:

The optical apparatus, weighing about 1 ton, rests on a circular cast-iron table, which is supported by a vertical shaft of wrought iron 2.36 in. diameter. This is kept in position at the top by a bronze ring and outer iron support, and at the bottom in the same way, while it rotates on a removable steel pivot resting in a steel socket, which is fitted to the base of the support. To the vertical shaft there is rigidly fixed a floating cast-iron ring 17.1 in. diameter and 11.8 in. in depth, which is plunged into and rotates in a mercury bath contained in a fixed outer drum or tank, the clearance between the vertical surfaces of the drum and ring being only 0.2 in., so as to reduce as much as possible the volume of mercury (about 220 lbs.), while the horizontal clearance at the bottom is 0.4 in.

**BALL-BEARINGS, ROLLER-BEARINGS, ETC.**

**Friction-rollers.** — If a journal instead of revolving on ordinary bearings be supported on friction-rollers the force required to make the journal revolve will be reduced in nearly the same proportion that the diameter of the axles of the rollers is less than the diameter of the rollers themselves. In experiments by A. M. Wellington with a journal 3 1/2 in. diam. supported on rollers 8 in. diam., whose axles were 1 3/4 in. diam., the friction in starting from rest was 1/4 the friction of an ordinary 3 1/2-in. bearing, but at a car speed of 10 miles per hour it was 1/2 that of the ordinary bearing. The ratio of the diam. of the axle to diam. of roller was 1 3/4 : 8, or as 1 to 4.6.

**Coefficients of Friction of Roller Bearings.** C. H. Benjamin, *Machy*. Oct., 1905. — Comparative tests of plain babbitted, McKeel plain roller, and Hyatt roller bearings gave the following values of the coefficient of friction at a speed of 560 r.p.m.:

Diameter of Journal.	Hyatt Bearing.			McKeel Bearing.			Babbitt Bearing.		
	Max.	Min.	Ave.	Max.	Min.	Ave.	Max.	Min.	Ave.
1 15/16	.032	.012	.018	.033	.017	.022	.074	.029	.043
2 3/16	.019	.011	.014	.....	.....	.....	.088	.078	.082
2 7/16	.042	.025	.032	.028	.015	.021	.114	.083	.096
2 15/16	.029	.022	.025	.039	.019	.027	.125	.089	.107

The friction of the roller-bearing is from one-fifth to one-third that of a plain bearing at moderate loads and speeds. It is noticeable that as the load on a roller-bearing increases the coefficient of friction decreases.

A slight change in the pressure due to the adjusting nuts was sufficient to increase the friction considerably. In the McKeel bearing the rolls

bore on a cast-iron sleeve and in the Hyatt on a soft-steel one. If roller bearings are properly adjusted and not overloaded a saving of from 2-3 to 3-4 of the friction may be reasonably expected.

McKeel bearings contained rolls turned from solid steel and guided by spherical ends fitting recesses in cage rings at each end. The cage rings were joined to each other by steel rods parallel to the rolls.

**Lubrication** is absolutely necessary with ball and roller bearings, although the contrary claim is often advanced. Under favorable conditions an almost imperceptible film is sufficient; a sufficient quantity to immerse half the lowest ball should always be provided as a rust preventive. Rust and grit must be kept out of ball and roller bearings. Acid or rancid lubricants are as destructive as rust. (Henry Hess.)

Both ball and roller bearings, to give the best satisfaction, should be made of steel, hardened and ground; accurately fitted, and in proper alignment with the shaft and load; cleaned and oiled regularly, and fitted with as large-size balls or rollers as possible, depending upon the revolutions per minute and load to be carried. Oil is absolutely necessary on both ball and roller bearings, to prevent rust. (S. S. Eveland.)

**Roller Bearings.** — The Mossberg roller bearings for journals are made in the sizes given in the table below.  $D$  = diam. of journal;  $d$  = diam. of roll;  $N$  = number of rolls;  $P$  = safe load on journals, in lbs. The rolls are enclosed in a bronze supporting cage. (*Trans. A. S. M. E.*, 1905.)

$D$	$d$	$N$	$P$	$D$	$d$	$N$	$P$	$D$	$d$	$N$	$P$
2	1/4	20	3,500	6	11/16	24	50,000	15	13/8	28	255,000
2 1/2	5/16	22	7,000	7	13/16	22	70,000	18	13/8	32	325,000
3	3/8	22	13,000	8	7/8	22	90,000	20	1 1/2	34	400,000
4	7/16	24	24,000	9	1	24	115,000	24	1 1/2	38	576,000
5	9/16	24	37,000	12	1 1/4	26	175,000				

Surface speed of journal 0 to 50 ft. per min. Length of journal 1 1/2 diameters. The rolls are made of tool steel not too high in carbon, and of spring temper. The journal or shaft should be made not above a medium spring temper. The box should be made of high carbon steel and tempered as hard as possible.

**Conical Roller Thrust Bearings.** — The Mossberg thrust bearing is made of conical rollers contained in a cage, and two collars, one being stationary and the other fixed to the shaft and revolving with it. One side of each collar is made conical to correspond with the rollers which bear on it. The apex of the cones is at the center of the shaft. The angle of the cones is 6 to 7 degrees. Larger angles are objectionable, giving excessive end thrust. The following sizes are made:

Diameter of Shaft. Ins.	Outside Diameter of Ring. Ins.	No. of Rolls.	Safe Pressure on Bearing.		
			Area of Pressure Plate. Sq. ins.	Speed 75 Rev. Lbs.	Speed 150 Rev. Lbs.
2 1/16-2 1/4	5 9/16	30	10	19,000	9,500
3 1/16-3 1/4	8	30	20	40,000	20,000
4 1/16-4 1/4	10 5/16	30	35	70,000	35,000
5 1/16-5 1/4	12 3/8	30	54	108,000	56,000
6 1/16-6 1/2	14 7/8	30	78	125,000	62,000
8 1/16-8 1/2	18 3/4	32	132	200,000	100,000
9 1/16-9 1/2	20 1/2	32	162	300,000	150,000

**Plain Roller Thrust Bearings.** — S. S. Eveland, of the Standard Roller Bearing Co., contributes the following data of plain roller thrust bearings in use in 1903. The bearing consists of a large number of short cylindrical rollers enclosed in openings in a disk placed between two hardened steel plates. He says "our plain roller bearing is theoretically wrong, but in practice it works perfectly, and has replaced many thousand ball-bearings which have proven unsatisfactory."



Size of Bearing, Ins.	Number and Size of Rollers, Ins.	R.p.m.	Wt. on Bearings, Lbs.	Lineal Inches.	Weight per lin. in., Lbs.	Weight on each Roll, Lb.
4 $\frac{3}{4}$ × 6 $\frac{11}{16}$	36 $\frac{5}{8}$ × $\frac{5}{16}$	500	6,000	11 $\frac{1}{4}$	546	167
4 $\frac{3}{4}$ × 7 $\frac{1}{4}$	32 $\frac{3}{4}$ × $\frac{5}{8}$	470	10,000	12	833	312
5 $\frac{1}{2}$ × 8 $\frac{1}{2}$	54 $\frac{3}{4}$ × $\frac{5}{8}$	420	15,000	20 $\frac{1}{4}$	750	279
7 × 10 $\frac{3}{8}$	48 1 × $\frac{1}{2}$	370	20,000	24	833	417
7 $\frac{1}{2}$ × 11 $\frac{5}{16}$	54 1 × $\frac{1}{2}$	325	25,000	27	988	463
8 × 15 $\frac{1}{2}$	70 1 $\frac{1}{4}$ × $\frac{5}{8}$	300	60,000	45	1334	833

**The Hyatt Roller Bearing.** (A. L. Williston, *Trans. A. S. M. E.*, 1905.) — The distinctive feature of the Hyatt roller bearing is a flexible roller, made of a strip of steel wound into a coil or spring of uniform diameter. A roller of this construction insures a uniform distribution of the load along the line of contact of the roller and the surfaces on which it operates. It also permits any slight irregularities in either journal or box without causing excessive pressure. The roller is hollow and serves as an oil reservoir. For a heavy load, a roller of heavy stock can be made, while for a high-speed bearing under light pressure a roller of light weight, made from thin stock, can be used. Following are the results of some tests of the Hyatt bearing in comparison with other bearings:

A shaft 152 ft. long, 2  $\frac{15}{16}$  in. diam. supported by 20 bearings, belt-driven from one end, gave a friction load of 2.28 H.P. with babbitted bearings, and 0.80 H.P. with Hyatt bearings. With 88 countershafts running in babbitted bearings, the H.P. required was 8.85 when the main shaft was in babbitted bearings and 6.36 H.P. when it was in Hyatt bearings.

Comparative tests of solid rollers and of Hyatt rollers were made in 1898 at the Franklin Institute by placing two sets of rollers between three flat plates, putting the plates under load in a testing machine and measuring the force required to move the middle plate. All the rollers were  $\frac{3}{4}$  in. diam., 10 ins. long. The Hyatt rollers were made of  $\frac{1}{2}$  ×  $\frac{1}{8}$  in. steel strip. With 2000 lbs. load and plain rollers it took 26 lbs. to move the plate, and with the Hyatt rollers 9 lbs. With 3000 lbs. load and plain rollers the resistance was 34 lbs., with Hyatt rollers 17 lbs.

In tests with a pendulum friction testing machine at the Case Scientific School, with a bearing 1  $\frac{15}{16}$  in. diam. the coefficient of friction with the Hyatt bearing was from 0.0362 down to 0.0196, the loads increasing from 64 to 264 lbs.; with cast-iron bearings and the same loads the coefficient was from 0.165 to 0.098.

In tests at Purdue University with bearings 4 × 1  $\frac{1}{2}$  ins. and loads from 1900 to 8300 lbs., the average coefficients with different bearings and different speeds were as follows:

Hyatt bearing	130 r.p.m.	0.0114	302 r.p.m.	0.0099	585 r.p.m.	0.0147
Cast-iron bearing	128	“	0.0548	302	“	0.0592
Bronze bearing	130	“	0.0576	320	“	0.0661
						582
						0.140

The cast-iron bearing at 128 r.p.m. seized with 8300 lbs., and at 410 r.p.m. with 5900 lbs. The bronze bearing seized at 130 r.p.m. with 3500 lbs., at 320 r.p.m. with 5100 lbs., and at 582 r.p.m. with 2700 lbs.

The makers have found that the advantages of roller bearings of the type described are especially great with either high speeds or heavy loads. Generally, the best results are obtained for line-shaft work up to speeds of 600 rev. per min., when a load of 30 lbs. per square inch of projected area is allowed. For heavy load at slow speed, such as in crane and truck wheels, a load of 500 lbs. gives the best results.

**The Friction Coefficient** of a well-made annular ball-bearing is 0.001 and 0.002 of the load referred to the shaft diameter and is independent of the speed and load. The friction coefficient of a good roller bearing is from 0.0035 to 0.014; it rises very much if the load is light. It increases also when the speeds are very low, though not so much as with plain bearings. (Henry Hess.)

**Notes on Ball Bearings.** — The following notes are contributed by Mr. Henry Hess, 1910. Ball bearings in modern use date from the bicycle. That brought in the adjustable cup and cone and three-point contact type. Under the demands for greater load resistance and reliability the two-point contact type, without adjustability, was evolved; that is now used under loads from a few pounds to many tons. Such a

bearing consists of an inner race, an outer race and the series of balls that roll in tracks of curved cross section. Various designs are used, differing chiefly in the devices for separating the balls and in the arrangement for introducing the balls between the races. The most widely used type has races that are of the same cross section throughout, unbroken by any openings for the introduction of balls. To introduce the balls the two races are first eccentrically placed; the balls will fill slightly more than a half circumference; elastic separators or solid cages are used to space the balls.

Another type has a filling opening of sufficient depth cut into one race; the race continuity is restored by a small piece that is let in. This type is usually filled with balls, without cages or separators. The filling opening is always placed at the unloaded side of the bearing, where the weakening of the race is not important. This type has been almost entirely discarded in favor of the one above described.

A third type has a filling opening cut into each race not quite deep enough to tangent the bottom of the ball track. As this weakened section necessarily comes under the load during each revolution, the carrying capacity is reduced. After slight wear there develops an interference of the balls with the edges of these openings, which seriously reduces the speeds and load capacity. This interference precludes the use of this type to take end thrust.

The carrying capacity of a ball-bearing is directly proportional to the number of balls and to the square of the ball diameter.

It may be written as:

$L = Knd^2$ , in which  $L$  = load capacity in pounds;  $n$  = number of balls;  $d$  = ball diameter in eighths of an inch.  $K$  varies with the condition and type of bearing, as also with the material and speed.

For a certain special steel that hardens throughout and is also unusually tough, employed by "DWF" or "HB" (the originators of the modern two-point type), the following values apply. For other steels lesser values must be used.

#### I. For Radial Bearings:

$K = 9$  for uninterrupted race track, cross-section curvature = 0.52 and  $9/16$  in. ball diameter respectively for inner and outer races, separated balls, uniform load, and steady speed up to 3000 revs. per min.

$K = 5$  for full ball type, filling opening in one race at the unloaded side, otherwise as above.

$K = 2.5$  for both ball tracks interrupted by filling openings, inelastic cage separators for balls, or full ball, speeds not above 2000 revs. per min., uniform load.

$K = 0.9$  for thrust on a radial bearing of the first type, as above. The larger the balls the smaller  $K$ . The type with filling openings in each race is not suitable for end thrust.

The radial load bearing is, up to high speeds, practically unaffected by speed, as to carrying capacity.

#### II. Thrust Bearings:

With the thrust type, consisting of one flat plate and one seat plate with grooved ball races, the load capacity decreases with speed or

$$L = \frac{K_1 nd^2}{\sqrt[3]{R}}$$

$K_1$  = constant for material and race cross-section, etc.,  $R$  = revolutions per minute.  $R$  ranges from about 3000 revs. per min. down to 1 rev. per min. as for crane hooks and similar elements.

$K_1 = 25$  to 40 for material used by the DWF or HB, and race cross-section radius = approx. 1.66 ball radius.

$K_1 = 0.5$  for unhardened steel, occasionally used for very large races; a steel that is fairly hard without tempering must be used, and then only when there is no hammering or sharp load variation.

Balls must be carefully selected to make sure that all that are used in the same bearing do not vary among one another by more than 0.0001 inch. A ball that is more than that larger than its fellows will sustain more than its proportion of the load, and may therefore be overloaded and will in turn overload the races.

The usual test of ball quality, which consists in compressing a ball between flat plates and noting the load at rupture, gives the quality of the plates, but not of the balls. It is the ability of the ball to resist permanent deformation that is of importance. As the deformations involved are very small the test is a difficult one to carry out. Of even greater importance than a small deformation under load is uniformity of such deformation between the balls employed; a hard ball will deform less than its softer mate and so will carry more than its share of the load, and will therefore be overloaded and in turn overload the races.

Coned bearings for balls are objectionable. The defect in all these forms of bearings is their adjustable feature. A bearing properly proportioned with reference to a certain load may be enormously overloaded by a little extra effort applied to the wrench, or on the other hand the bearing may be adjusted with too little pressure, so that the balls will rattle, and the results consequently be unsatisfactory. The prevalent idea that coned ball-bearings can be adjusted to compensate for wear is erroneous.

Mr. Hess's paper, in *Trans. A. S. M. E.*, 1907, contains a great deal of useful information on the practical design of ball-bearings, including different forms of raceways. He prefers a two-point bearing, in which the ball races have a curved section, with sustaining surfaces at right angles with the direction of the load.

**Formulae for Number of Balls in a Bearing.** (H. Rolfe, *Am. Mach.*, Dec. 3, 1896.)—Let  $D$  = diam. of ball circle (the circle passing through the centers of the balls);  $d$  = diam. of balls;  $n$  = number of balls;  $s$  = average clearance space between the balls. Then  $D = (d + s) \div \sin(180^\circ/n)$ ;  $d = D \sin(180^\circ/n) - s$ ;  $s = D \sin(180^\circ/n) - d$ ;  $n = 180^\circ \div$  angle whose sine is  $(d + s) \div D$ . The clearance  $s$  should be about 0.003 in.

VALUES OF  $180^\circ/n$  AND OF  $\sin 180^\circ/n$ .

$n$ .	$180^\circ/n$ .	$\sin 180^\circ/n$ .	$n$ .	$180^\circ/n$ .	$\sin 180^\circ/n$ .	$n$ .	$180^\circ/n$ .	$\sin 180^\circ/n$ .	$n$ .	$180^\circ/n$ .	$\sin 180^\circ/n$ .
3	60	0.86603	15	12	0.20791	27	6.667	0.11609	39	4.615	0.08047
4	45	.70711	16	11.250	.19509	28	6.429	.11197	40	4.500	.07846
5	36	.58799	17	10.588	.18375	29	6.207	.10812	41	4.390	.07655
6	30	.50000	18	10	.17365	30	6	.10453	42	4.286	.07473
7	25.714	.43388	19	9.474	.16454	31	5.806	.10117	43	4.186	.07300
8	22.500	.38268	20	9	.15643	32	5.625	.09801	44	4.091	.07134
9	20	.34202	21	8.571	.14904	33	5.455	.09506	45	4	.06976
10	18	.30902	22	8.182	.14233	34	5.294	.09227	46	3.913	.06825
11	16.364	.28173	23	7.826	.13616	35	5.143	.08963	47	3.830	.06679
12	15	.25882	24	7.500	.13053	36	5	.08716	48	3.750	.06540
13	13.846	.23931	25	7.200	.12533	37	4.865	.08510	49	3.673	.06407
14	12.857	.22252	26	6.923	.12055	38	4.737	.08258	50	3.600	.06279

**Grades of Balls for Bearings.** (S. S. Eveland, *Trans. A. S. M. E.*, 1905.) — "A" grade balls vary about 0.0025 in. in diameter; "B" grade, 0.001 to 0.002 in.; while "high-duty" or special balls are furnished varying not over 0.0001 in. The crushing strength of balls is of little importance as to the load a bearing will carry, the revolutions per minute being quite as important as the load.

**Saving of Power by Use of Ball-Bearings.** — Henry Hess (*Trans. A. S. M. E.*, 1909) describes a series of tests made by Dodge and Day on a  $2\frac{15}{16}$  in. line shaft 72 ft. long, alternately equipped with plain ring-oiling babbitted boxes and with Hess-Bright ball-bearings. Eight countershafts were driven from pulleys on the line shaft. The countershaft pulleys had plain bearings. The conclusions from the tests made under normal belt conditions of 44 and 57 lbs. per inch width of angle of single belt are as follows:

a. Savings due to the substitution of ball-bearings for plain bearings on line shafts may be safely calculated by using 0.0015 as the coefficient of ball-bearing friction, 0.03 as the coefficient of line shaft friction, and 0.08 as the coefficient of countershaft friction.

b. When the belts from line shaft to countershaft pull all in one direction and nearly horizontally the saving due to the substitution of ball-



bearings for plain bearings on the line shaft may be safely taken as 35% of the bearing friction.

c. When ball-bearings are used also on the countershafts the savings will be correspondingly greater and may amount to 70% or more of the bearing friction.

d. These percentages of savings are percentages of the friction work lost in the plain bearings; they are not percentages of the total power transmitted. The latter will depend upon the ratio of the total power transmitted to that absorbed in the line and countershafts.

e. The power consumed in the plain line and countershafts varies, as is well known, from 10 to 60% in different industries and shops. The substitution of ball-bearings for plain bearings on the line shaft only, under conditions of paragraph "a," will thus result in saving of total power of  $35 \times 0.10 = 3.5\%$  to  $35 \times 0.60 = 21\%$ . By using ball-bearings on the countershafts also, the saving of total power will be from  $70 \times 0.10 = 7\%$  to  $70 \times 0.60 = 42\%$ .

### KNIFE-EDGE BEARINGS.

Allowable loads on knife-edges vary with the manner in which the pivots or knife-edges are held in the lever and the pivot supports or seats secured to the base of weighing machines. The extension of the pivot beyond the solid support is practically worthless. A high-grade uniform tool steel with carbon 0.90% to 1.00% should be used. The temper of the seats should be drawn to a very light straw color; that of the pivots should be slightly darker. The angle of 90° for the knife-edge has given good results for heavy loads. For ordinary weighing machinery and most testing machinery 5000 lbs. per inch of length is ample. Loads of 10,000 lbs. per inch of length are permissible, but the pivot must be flat at its upper portion, normal to the load and supported its whole length, with a minimum deflection of parts to secure reasonable accuracy. The edge may be made perfectly sharp, for loads up to 1000 lbs. per inch of length. For greater loads the sharp edge is rubbed with an oilstone, so that a smoothness is just visible. A pronounced radius of knife-edge will decrease the sensibility of the apparatus. (Jos. W. Bramwell, *Eng. News*, June 14, 1906.)

### FRICTION OF STEAM-ENGINES.

**Distribution of the Friction of Engines.** — Prof. Thurston, in his "Friction and Lost Work," gives the following:

	1.	2.	3.
Main bearings.....	47.0	35.4	35.0
Piston and rod.....	32.9	25.0	21.0
Crank-pin.....	6.8	5.1	13.0
Cross-head and wrist-pin.....	5.4	4.1	
Valve and rod.....	2.5	26.4	22.0
Eccentric strap.....	5.3	4.0	
Link and eccentric.....	....	....	9.0
Total.....	100.0	100.0	100.0

No. 1, Straight-line, 6 × 12 in., balanced valve; No. 2, Straight-line, 6 × 12 in., unbalanced valve; No. 3, 7 × 10 in., Lansing traction, locomotive valve-gear.

Prof. Thurston's tests on a number of different styles of engines indicate that the friction of any engine is practically constant under all loads. (*Trans. A. S. M. E.*, viii, 86; ix, 74.)

In a straight-line engine, 8 × 14 in., I.H.P. from 7.41 to 57.54, the friction H.P. varied irregularly between 1.97 and 4.02, the variation being independent of the load. With 50 H.P. on the brake the I.H.P. was only 52.6, the friction being only 2.6 H.P., or about 5%.

A compound condensing-engine, tested from 0 to 102.6 brake H.P., gave I.H.P. from 14.92 to 117.8 H.P., the friction H.P. varying only from 14.92 to 17.42. At the maximum load the friction was 15.2 H.P., or 12.9%.

The friction increases with increase of the boiler-pressure from 30 to 70 lbs., and then becomes constant. The friction generally increases with increase of speed, but there are exceptions to this rule.

Prof. Denton (*Stevens Indicator*, July, 1890), comparing the calculated friction on a number of engines with the friction as determined by measure-

ment, finds that in one case, a 75-ton ammonia ice-machine, the friction of the compressor, 17½ H.P., is accounted for by a coefficient of friction of 7½% on all the external bearings, allowing 6% of the entire friction of the machine for the friction of pistons, stuffing-boxes, and valves. In the case of the Pawtucket pumping-engine, estimating the friction of the external bearings with a coefficient of friction of 6% and that of the pistons, valves, and stuffing-boxes as in the case of the ice-machine, we have the total friction distributed as follows:

	Horse-power.	Per cent of whole.
Crank-pins and effect of piston-thrust on main shaft	0.71	11.4
Weight of fly-wheel and main shaft	1.95	32.4
Steam-valves	0.23	3.7
Eccentric	0.07	1.2
Pistons	0.43	7.2
Stuffing-boxes, six altogether	0.72	11.3
Air-pump	2.10	32.8
Total friction of engine with load	6.21	100.0
Total friction per cent of indicated power	4.27	

The friction of this engine, though very low in proportion to the indicated power, is satisfactorily accounted for by Morin's law used with a coefficient of friction of 5%. In both cases the main items of friction are those due to the weight of the fly-wheel and main shaft and to the piston-thrust on crank-pins and main-shaft bearings. In the ice-machine the latter items are the larger owing to the extra crank-pin to work the pumps, while in the Pawtucket engine the former preponderates, as the crank-thrusts are partly absorbed by the pump-pistons, and only the surplus effect acts on the crank-shaft.

Prof. Denton describes in *Trans. A. S. M. E.*, x. 392, an apparatus by which he measured the friction of the piston packing-ring. When the parts of the piston were thoroughly devoid of lubricant, the coefficient of friction was found to be about 7½%; with an oil-feed of one drop in two minutes the coefficient was about 5%; with one drop per minute it was about 3%. These rates of feed gave unsatisfactory lubrication, the piston groaning at the ends of the stroke when run slowly, and the flow of oil left upon the surfaces was found by analysis to contain about 50% of iron. A feed of two drops per minute reduced the coefficient of friction to about 1%, and gave practically perfect lubrication, the oil retaining its natural color and purity.

### FRICION BRAKES AND FRICION CLUTCHES.

**Friction Brakes** are used for slowing down or stopping a moving machine by converting its energy of motion into heat, or for controlling the speed of a descending load. The simplest form is the block brake, commonly used for railway car wheels, which resists the motion of the wheel not only with the force due to ordinary sliding friction, but with that due to cutting or grinding away the surface of the metals in contact. If  $P$  = total pressure acting normal to the sliding surface,  $f$  = coefficient of friction, and  $v$  = velocity in feet per minute, then the energy absorbed, in foot-pounds per minute, is  $Pfv$ . If the surface is lubricated and the pressure per square inch not great enough to squeeze out the lubricant, then the value of  $f$  for different materials may be taken from Morin's tables for friction of motion, page 1221, but if the pressure is great enough to force out the lubricant, then the coefficient becomes much greater and the surfaces will cut and wear, with a rapid rise of temperature.

Other forms of brakes are disk brakes and cone brakes, in which a disk or cone is carried by the rotating shaft and a mating disk or cone is pressed against it by a lever or other means; and band brakes, also called strap or ribbon brakes, in which a flexible band encircles the cylindrical surface of a rotating drum or wheel, and tension applied to one end of the band brings it in contact with that surface. For band brakes the theory of friction of belts applies. See page 1138. For much information on the theory and practice of friction brakes see articles by C. F. Blake in *Mach'y*, Jan., 1901, Mar., 1905, and Aug., 1906, and by E. R. Douglas, *Am. Mach.*, Dec. 26, 1901, and R. B. Brown, *Mach'y*, April, 1909. For friction brake dynamometers see Dynamometers.

**Friction Clutches** are used for putting shafts in motion gradually, without shock. If two shafts, in line with each other, one in motion and the other at rest, each having a disk keyed to the end, and the disks almost touching, are moved toward each other so that the disks are brought in contact with some pressure, the shaft at rest will be put in motion gradually, while the disks rub on each other, until it acquires the velocity of the driving shaft, when the friction ceases and the disks may then be locked together. This is an elementary form of friction clutch. A great variety of styles are made in which the sliding surfaces may be disks, cones, and gripping blocks of various forms. The work done by a clutch while the surfaces are in sliding contact, and before they are locked together, is the overcoming of the inertia of the driven shaft and of all the mechanism driven by it, and giving it the velocity of the driving shaft. The principles of friction brakes apply to friction clutches. The sliding surfaces must be of sufficient area to keep the normal pressure below that at which they will overheat, cut and wear, and to dissipate the heat generated by friction. The following values of the coefficient of friction to be used in designing clutches are given by C. W. Hunt: cork on iron, 0.35; leather on iron, 0.3; wood on iron, 0.2; iron on iron, 0.25 to 0.3. Lower values than these should be assumed for velocities exceeding 400 ft. per minute. The pressure per square inch in disk clutches should not exceed 25 or 30 lbs., and wooden surfaces should not be loaded beyond 20 to 25 lbs. per sq. in. See Kimball and Barr on Machine Design, also *Trans. A. S. M. E.*, 1903 and 1908.

**Electrically Operated Brakes** are discussed by H. A. Steen in a paper read before the Engrs. Socy. of W. Penna., reprinted in *Iron Trade Rev.*, Dec. 24, 1908. Formulæ are given for the time required for stopping, for the heat generated and the temperature rise, for different types of brakes.

**Magnetic and Electric Brakes.**—For braking the load on electric cranes a band brake is used which is held off the drum by the action of a magnet or solenoid, and is put on by the action of a spring or weight. The solenoid usually consists of a coil of wire connected in series with the motor, and a plunger working inside of the coil. It should be so proportioned that its action is not delayed by residual magnetism when the current is cut off. Too rapid action is prevented by making the end of the solenoid an air dash-pot.

For electric-driven machinery an electric motor makes a most efficient brake by reversing the direction of the electric current, causing the motor to become a generator supplying current to a rheostat in which it is converted into heat and dissipated. In some cases the electric current generated, instead of being absorbed in a rheostat, is fed into the main electric circuit. In this case the energy of the rotating mass, instead of being wasted in friction or in electrical heating, is converted into electric energy and thus conserved for further use.

**Design of Band Brakes.** (R. A. Greene, *Am. Mach.*, Oct. 8, 1908.)—In the practice of the Browning Engineering Co., Cleveland, O., in regard to the design of band brakes the equations are:

$$T = PX, t = T - P, S = \frac{2T}{D \times F}, \vartheta = S \times D \times 0.262 \times \text{revolutions per minute, in which } T = \text{the greater tension on the band, } t = \text{the lesser tension on the band, } P = \text{equivalent load on the brake drum, } X = \text{factor from the accompanying table, } X = \frac{N}{N-1} \text{ in which } \log. N = 10^{2.7288} fc,$$

where  $f$  = the coefficient of friction and  $c$  the length of arc of contact in degrees divided by 360.  $D$  = diam. of brake drum,  $F$  = width of face of brake drum,  $S$  = a checking factor which has a maximum limit of 65,  $\vartheta$  = a checking factor which has a limit of 54,000 (Yale & Towne practice) or 60,000 (Brown hoist practice).

**EXAMPLE.**—A band brake is to be designed having an arc of contact of  $260^\circ$ , coefficient of friction = 0.2, drum diameter 30 ins., face 4 ins., speed 100 r.p.m., and a load of 3000 lbs. acting on a diameter of 20 ins. Then

$$P = 3000 \times 20 \div 30 = 2000 \text{ pounds, } X = 1.68 \text{ (from table), } T = 2000 \times 1.68 = 3360 \text{ pounds, } t = 3360 - 2000 = 1360 \text{ pounds, } S = 2 \times 3360 \div (30 \times 4) = 56 \text{ (within the limit), } \vartheta = 56 \times 30 \times 0.262 \times 100 = 44,000 \text{ (within the limit).}$$



Degrees.	Values of X.			Degrees.	Values of X.		
	f = 0.2.	f = 0.3.	f = 0.4.		f = 0.2.	f = 0.3.	f = 0.4.
180	2.14	1.64	1.40	260	1.68	1.35	1.19
195	2.03	1.56	1.35	270	1.64	1.32	1.18
210	1.93	1.50	1.30	280	1.60	1.30	1.17
240	1.76	1.40	1.23	290	1.57	1.28	1.15
250	1.72	1.37	1.21	300	1.54	1.26	1.14

**FRICITION OF HYDRAULIC PLUNGER PACKING.**

The "Taschenbuch der Hutte" (15th edition, vol. 1, p. 202) says: "For stuffing-boxes with hemp, cotton or leather packing, with water pressures between 1 and 50 atmospheres, the frictional loss is dependent upon the water pressure, the circumference of the packed surface, and a coefficient  $\mu$ , which is constant for this range of pressure. The loss is independent of the depth of stuffing-box or leather ring, and is given by the formula  $F = Kpd$ , in which  $F$  = total frictional loss in pounds,  $p$  = pressure in pounds per sq. in.,  $d$  = diameter of plunger in inches.

$K$  is a coefficient, which depends on the kind and condition of the packing, and is given as follows for various cases.

For cotton or hemp, loose or braided, dipped in hot tallow; plungers smooth, glands not pulled down too tight, packing therefore retaining its elasticity; dimensions such as usually occur,  $K = 0.072$ .

Same conditions, after packing is some months old,  $K = 0.132$ .

Materials the same, but with hard packing, unfavorable conditions, etc.,  $K$  = as much as 0.299.

Leather packing; soft leather, well made, etc.,  $K = 0.036$  to 0.084.

Hard, stiffly tanned leather,  $K = 0.12$  to 0.156.

Unfavorable conditions; rough plungers, gritty water, etc.,  $K$  = as much as 0.239.

Weisbach-Hermann, "Mechanics of Hoisting Machinery," gives a formula which when translated into the same notation as the one in "Hutte" is

$$F = 0.0312 pd \text{ to } 0.0767 pd.$$

Since the total pressure on a plunger is  $\frac{1}{4}\pi d^2 p$ , the ratio of the loss of pressure to the total pressure is  $Kpd \div \frac{1}{4}\pi d^2 p$ , or, using the extreme values of  $K$ , 0.0312 and 0.299, the ratio ranges from 0.04  $\div d$  to 0.38  $\div d$ , or from 4 to 38 per cent divided by the diameter in inches.

Walter Ferris (*Am. Mach.*, Feb. 3, 1898) derives from the formula given above the following formula for the pressure produced by a hemp-packed hydraulic intensifier made with two plungers of different diameters:

$$p_2 = p_1 \frac{A - KD}{a + kd},$$

in which  $p_2$  = pressure per sq. in. produced by the intensifier,  $p_1$  = initial pressure,  $A$  = area and  $D$  = diam. of the larger plunger,  $a$  = area and  $d$  = diam. of the smaller plunger, and  $K$  an experimental coefficient. He gives the following results of tests of an intensifier with a small plunger 8 ins. diam. and two large plungers, 14 $\frac{1}{4}$  and 17 $\frac{3}{4}$  ins., either one of which could be used as desired.

Diam. of large plunger, in.	14 $\frac{1}{4}$	14 $\frac{1}{4}$	17 $\frac{3}{4}$	17 $\frac{3}{4}$
Initial pressure, lbs. per sq. in.	285	475	335	350
Intensified pressure, lbs. per sq. in.	750	1450	1450	1510
Intensified if there were no friction	905	1505	1650	1725
Intensified calculated by formula*	806	1433	1572	1643
Efficiency of machine	0.83	0.965	0.88	0.875

**LUBRICATION.**

**Measurement of the Durability of Lubricants.** — (J. E. Denton, *Trans. A. S. M. E.*, xi, 1013.) — Practical differences of durability of lubricants depend not on any differences of inherent ability to resist being "worn out" by rubbing, but upon the rate at which they flow through and away from the bearing-surfaces. The conditions which

\* Assuming  $K = 0.2$ . The efficiency calculated by the formula in each case was 0.953.

control this flow are so delicate in their influence that all attempts thus far made to measure durability of lubricants may be said to have failed to make distinctions of lubricating value having any practical significance. In some kinds of service the limit to the consumption of oil depends upon the extent to which dust or other refuse becomes mixed with it, as in railroad-car lubrication and in the case of agricultural machinery. The economy of one oil over another, so far as the quality used is concerned — that is, so far as durability is concerned — is simply proportional to the rate at which it can insinuate itself into and flow out of minute orifices or cracks. Oils will differ in their ability to do this, first, in proportion to their viscosity, and, second, in proportion to the capillary properties which they may possess by virtue of the particular ingredients used in their composition. Where the thickness of film between rubbing-surfaces must be so great that large amounts of oil pass through bearings in a given time, and the surroundings are such as to permit oil to be fed at high temperatures or applied by a method not requiring a perfect fluidity, it is probable that the least amount of oil will be used when the viscosity is as great as in the petroleum cylinder stocks. When, however, the oil must flow freely at ordinary temperatures and the feed of oil is restricted, as in the case of crank-pin bearings, it is not practicable to feed such heavy oils in a satisfactory manner. Oils of less viscosity or of a fluidity approximating to lard-oil must then be used.

**Relative Value of Lubricants.** (J. E. Denton, *Am. Mach.*, Oct. 30, 1890.) — The three elements which determine the value of a lubricant are the cost due to consumption of lubricants, the cost spent for coal to overcome the frictional resistance caused by use of the lubricant, and the cost due to the metallic wear on the journal and the brasses.

**The Qualifications of a Good Lubricant,** as laid down by W. H. Bailey, in *Proc. Inst. C. E.*, vol. xlv, p. 372, are: 1. Sufficient body to keep the surfaces free from contact under maximum pressure. 2. The greatest possible fluidity consistent with the foregoing condition. 3. The lowest possible coefficient of friction, which in bath lubrication would be for fluid friction approximately. 4. The greatest capacity for storing and carrying away heat. 5. A high temperature of decomposition. 6. Power to resist oxidation or the action of the atmosphere. 7. Freedom from corrosive action on the metals upon which the lubricant is used.

**The Examination of Lubricating Oils.** (Prof. Thos. B. Stillman, *Stevens Indicator*, July, 1890.) — The generally accepted conditions of a good lubricant are as follows:

1. "Body" enough to prevent the surfaces to which it is applied from coming in contact with each other. (Viscosity.)

2. Freedom from corrosive acid, of either mineral or animal origin.

3. As fluid as possible consistent with "body."

4. A minimum coefficient of friction.

5. High "flash" and burning points.

6. Freedom from materials liable to produce oxidation or "gumming."

The examinations to be made to verify the above are both chemical and mechanical, and are usually arranged in the following order:

1. Identification of the oil, whether a simple mineral oil, or animal oil, or a mixture. 2. Density. 3. Viscosity. 4. Flash-point. 5. Burning-point. 6. Acidity. 7. Coefficient of friction. 8. Cold test.

Detailed directions for making all of the above tests are given in Prof. Stillman's article. See also Stillman's *Engineering Chemistry*, p. 366.

**Notes on Specifications for Petroleum Lubricants.** (C. M. Everest, Vice-Pres. Vacuum Oil Co., *Proc. Engineering Congress*, Chicago World's Fair, 1893.) — The specific gravity was the first standard established for determining quality of lubricating oils, but it has long since been discarded as a conclusive test of lubricating quality. However, as the specific gravity of a particular petroleum oil increases the viscosity also increases.

The object of the fire test of a lubricant, as well as its flash test, is the prevention of danger from fire through the use of an oil that will evolve inflammable vapors. The lowest fire test permissible is 300°, which gives a liberal factor of safety under ordinary conditions.

The cold test of an oil, i. e., the temperature at which the oil will congeal, should be well below the temperature at which it is used; otherwise the coefficient of friction would be correspondingly increased.

Viscosity, or fluidity, of an oil is usually expressed in seconds of time in which a given quantity of oil will flow through a certain orifice at the temperature stated, comparison sometimes being made with water, sometimes with sperm-oil, and again with rape-seed oil. It seems evident that within limits the lower the viscosity of an oil (without a too near approach to metallic contact of the rubbing surfaces) the lower will be the coefficient of friction. But we consider that each bearing in a mill or factory would probably require an oil of different viscosity from any other bearing in the mill, in order to give its lowest coefficient of friction, and that slight variations in the condition of a particular bearing would change the requirements of that bearing; and further, that when nearing the "danger point" the question of viscosity alone probably does not govern.

The requirement of the New England Manufacturers' Association, that an oil shall not lose over 5% of its volume when heated to 140° Fahr. for 12 hours, is to prevent losses by evaporation, with the resultant effects.

The precipitation test gives no indication of the quality of the oil itself, as the free carbon in improperly manufactured oils can be easily removed.

It is doubtful whether oil buyers who require certain given standards of laboratory tests are better served than those who do not. Some of the standards are so faulty that to pass them an oil manufacturer must supply oil he knows to be faulty; and the requirements of the best standards can generally be met by products that will give inferior results in actual service.

**Penna. R. R. Specifications for Petroleum Products, 1900.** — Five different grades of petroleum products will be used.

The materials desired under this specification are the products of the distillation and refining of petroleum unmixed with any other substances.

**150° Fire-test Oil.** — This grade of oil will not be accepted if sample (1) is not "water-white" in color; (2) flashes below 130° Fahrenheit; (3) burns below 151° Fahrenheit; (4) is cloudy or shipment has cloudy barrels when received, from the presence of glue or suspended matter; (5) becomes opaque or shows cloud when the sample has been 10 minutes at a temperature of 0° Fahrenheit.

**300° Fire-test Oil.** — This grade of oil will not be accepted if sample (1) is not "water-white" in color; (2) flashes below 249° Fahrenheit; (3) burns below 298° Fahrenheit; (4) is cloudy or shipment has cloudy barrels when received, from the presence of glue or suspended matter; (5) becomes opaque or shows cloud when the sample has been 10 minutes at a temperature of 32° Fahrenheit; (6) shows precipitation when some of the sample is heated to 450° F. The precipitation test is made by having about two fluid ounces of the oil in a six-ounce beaker, with a thermometer suspended in the oil, and then heating slowly until the thermometer shows the required temperature. The oil changes color, but must show no precipitation.

**Paraffine and Neutral Oils.** — These grades of oil will not be accepted if the sample from shipment (1) is so dark in color that printing with long-primer type cannot be read with ordinary daylight through a layer of the oil 1/2 inch thick; (2) flashes below 298° F.; (3) has a gravity at 60° F., below 24° or above 35° Baumé; (4) from October 1st to May 1st has a cold test above 10° F., and from May 1st to October 1st has a cold test above 32° F.

The color test is made by having a layer of the oil of the prescribed thickness in a proper glass vessel, and then putting the printing on one side of the vessel and reading it through the layer of oil with the back of the observer toward the source of light.

**Well Oil.** — This grade of oil will not be accepted if the sample from shipment (1) flashes, from May 1st to October 1st, below 298° F., or from October 1st to May 1st, below 249° F.; (2) has a gravity at 60° F., below 28° or above 31° Baumé; (3) from October 1st to May 1st has a cold test above 10° F., and from May 1st to October 1st has a cold test above 32° F.; (4) shows any precipitation when 5 cubic centimeters are mixed with 95 c.c. of gasoline. The precipitation test is to exclude tarry and suspended matter. It is made by putting 95 c.c. of 88° B. gasoline, which must not be above 80° F. in temperature, into a 100 c.c. graduate, then adding the prescribed amount of oil and shaking thoroughly. Allow to stand ten minutes. With satisfactory oil no separated or precipitated material can be seen.



500° *Fire-test Oil*. — This grade of oil will not be accepted if sample from shipment (1) flashes below 494° F.; (2) shows precipitation with gasoline when tested as described for well oil.

Printed directions for determining flashing and burning tests and for making cold tests and taking gravity are furnished by the railroad company.

**Penna. R. R. Specifications for Lubricating Oils (1894).** (In force in 1902.)

Constituent Oils.	Parts by volume.								
Extra lard-oil.....	.....	.....	1	1	.....	.....	.....	1	
Extra No. 1 lard-oil.....	.....	.....	1	1	2	1	1	.....	
500° fire-test oil.....	1	1	1	1	1	1	2	4	
Paraffine oil.....	.....	4	2	1	.....	.....	.....	.....	
Well oil.....	1	.....	.....	.....	4	2	1	.....	
Used for.....	A	B	C <sub>1</sub>	C <sub>2</sub>	C <sub>3</sub>	D <sub>1</sub>	D <sub>2</sub>	D <sub>3</sub>	E

A, freight cars; engine oil on shifting-engines; miscellaneous greasing in foundries, etc. B, cylinder lubricant on marine equipment and on stationary engines. C, engine oil; all engine machinery; engine and tender truck boxes; shafting and machine tools; bolt cutting; general lubrication except cars. D, passenger-car lubrication. E, cylinder lubricant for locomotives. C<sub>1</sub>, D<sub>1</sub>, for use in Dec., Jan., and Feb.; C<sub>2</sub>, D<sub>2</sub>, in March, April, May, Sept., Oct., and Nov.; C<sub>3</sub>, D<sub>3</sub>, in June, July, and August. Weights per gallon, A, 7.4 lbs.; B, C, D, E, 7.5 lbs.

**Grease Lubricants.** — Tests made on an Olsen lubricant testing machine at Cornell University are reported in *Power*, Nov. 9, 1909. It was found that some of the commercial greases stood much higher pressures than the oils tested, and that the coefficients of friction at moderate loads were often as low as those of the oils. The journal of the testing machine was 3<sup>3</sup>/<sub>4</sub> in. diam., 3<sup>1</sup>/<sub>2</sub> in. long, and the babbitt bearing shoe had a projected area of 5.8 sq. in. The speed was 240 r.p.m. and each test lasted one hour, except when the bearing showed overheating. The following are the coefficients of friction obtained in the tests:

Lbs. per sq. in.	Min-eral Grease.	Ani-mal Grease.	Graph-ite Grease.	Min-eral Grease.	Engine Oil.	Engine Oil.	Grease.	Grease.
86.2	0.024	0.023	0.04	0.023	0.019	0.015	0.020	0.025
172.4	0.021	0.023	0.05	0.018	0.04	0.022	0.015	0.022
258.6	0.021	0.023	.....	0.018	0.06	0.037	0.014	0.020
344.8	0.025	0.025	.....	0.019	.....	.....	0.017	0.020
431.0	0.050	0.035	.....	0.028	.....	.....	0.026	0.019

**Testing Oil for Steam Turbines.** (Robert Job, *Trans. Am. Soc. for Testing Mats.*, 1909.) —

In some types of steam-turbines, the bearings are very closely adjusted and, if the oil is not clear and free from waxy substances, clogging and heating quickly results. A number of red engine and turbine oils some of which had given good service and others bad service were tested and it was found that clearness and freedom from turbidity were of importance, but mere color, or lack of color, seemed to have little influence, and good service results were obtained with oils which were of a red color, as well as with those which were filtered to an amber color.

**Heating Test.** — It was found that on heating the oils to 450° F. all which had given bad service showed a marked darkening of color, while those which had proved satisfactory showed little change. With oils that had been filtered or else had been chemically treated in such manner that the so-called "amorphous waxes" had been completely removed, on applying the heating test only a slight darkening of color resulted. It is of advantage in addition to other requirements to specify that an oil for steam turbines on being heated to 450° F. for five minutes shall show not more than a slight darkening of color. The test is that commonly used in test of 300° oil for burning purposes.

**Separating Test.** — It is known that elimination of the waxes causes an increase in the ease with which the oil separates from hot water when thoroughly shaken with it. This condition can be taken advantage of by prescribing that when one ounce of the oil is placed in a 4-oz. bottle

with two ounces of boiling water, the bottle corked and shaken hard for one minute and let stand, the oil must separate from the water within a specified time, depending upon the nature of the oil, and that there must be no appearance of waxy substances at the line of demarcation between the oil and the water.

**Quantity of Oil needed to Run an Engine.**—The Vacuum Oil Co. in 1892, in response to an inquiry as to cost of oil to run a 1000-H.P. Corliss engine, wrote: The cost of running two engines of equal size of the same make is not always the same. Therefore, while we could furnish figures showing what it is costing some of our customers having Corliss engines of 1000 H.P., we could only give a general idea, which in itself might be considerably out of the way as to the probable cost of cylinder- and engine-oils per year for a particular engine. Such an engine ought to run readily on less than 8 drops of 600 W oil per minute. If 3000 drops are figured to the quart, and 8 drops used per minute, it would take about two and one half barrels (52.5 gallons) of 600 W cylinder-oil, at 65 cents per gallon, or about \$85 for cylinder-oil per year, running 6 days a week and 10 hours a day. Engine-oil would be even more difficult to guess at what the cost would be, because it would depend upon the number of cups required on the engine, which varies somewhat according to the style of the engine. It would doubtless be safe, however, to calculate at the outside that not more than twice as much engine-oil would be required as of cylinder-oil.

The Vacuum Oil Co. in 1892 published the following results of practice with "600 W" cylinder-oil:

Corliss compound engine,	{	20 and 33 × 48; 83 revs. per min.; 1 drop of oil per min. to 1 drop in two minutes.
“ triple exp. “	{	20, 33, and 46 × 48; 1 drop every 2 minutes.
Porter-Allen	{	20 and 36 × 36; 143 revs. per min.; 2 drops of oil per min., reduced afterwards to 1 drop per min.
Ball	{	15 and 25 × 16; 240 revs. per min.; 1 drop every 4 minutes.

Results of tests on ocean-steamers communicated to the author by Prof. Denton in 1892 gave: for 1200-H.P. marine engine, 5 to 6 English gallons (6 to 7.2 U. S. gals.) of engine-oil per 24 hours for external lubrication; and for a 1500-H.P. marine engine, triple expansion, running 75 revs. per min., 6 to 7 English gals. per 24 hours. The cylinder-oil consumption is exceedingly variable, — from 1 to 4 gals. per day on different engines, including cylinder-oil used to swab the piston-rods.

**Cylinder Lubrication.**—J. H. Spoor, in *Power*, Jan. 4, 1910, has made a study of a great number of records of the amount of oil used for lubricating cylinders of different engines, and has reduced them to a systematic basis of the equivalent number of pints of oil used in a 10-hour day for different areas of surface lubricated. The surface is determined in square inches by multiplying the circumference of the cylinder by the length of stroke. The results are plotted in a series of curves for different types of engines, and approximate average figures taken from these curves are given below:

Compound Engines.

Sq. ins. lubricated . . . . .	2,000	4,000	6,000	8,000	10,000	12,000	18,000
Pints of oil used in 10 hrs.	2	3.5	4.3	5	5.5	6	6.5

Corliss Engines.

Sq. ins. lubricated . . . . .		1,000	2,000	3,000	4,000
Pints of oil in 10 hrs. Avge. . . . .		0.9	1.65	2.25	3.75
Max. . . . .		1.2	2.25	....	....
Min. . . . .		....	1.00	....	....

Automatic high-speed engines, about 2 pints per 1,000 sq. in.

Simple slide-valve engines, about 0.5 pint per 1,000 sq. in.

As shown in the figures under 2,000 Corliss, a certain engine may take 2¼ times as much oil as another engine of the same size. The difference may be due to smoothness of cylinder surface, kind and pressure of piston rings, quality of oil, method of introducing the lubricant, etc. Variations in speed of a given type of engine and in steam pressure do not appear to make much difference, but the small automatic high-speed engine takes more oil than any other type. Vertical marine engines are commonly run

without any cylinder oil, except that used occasionally to swab the piston rods.

**Quantity of Oil used on a Locomotive Crank-pin.** — Prof. Denton, *Trans. A. S. M. E.*, xi, 1020, says: A very economical case of practical oil-consumption is when a locomotive main crank-pin consumes about six cubic inches of oil in a thousand miles of service. This is equivalent to a consumption of one milligram to seventy square inches of surface rubbed over.

**Soda Mixture for Machine Tools.** (Penna. R. R. 1894.) — Dissolve 5 lbs. of common sal-soda in 40 gallons of water and stir thoroughly. When needed for use mix a gallon of this solution with about a pint of engine oil. Used for the cutting parts of machine tools instead of oil.

**Water as a Lubricant.** (C. W. Naylor, *Trans. A. S. M. E.*, 1905.) — Two steel jack-shafts 18 ft. long with bearings 5 X 14 ins. each receiving 175 H.P. from engines and driving 5 electric generators, with six belts all pulling horizontally on the same side of the shaft, gave trouble by heating when lubricated with oil or grease. Water was substituted, and the shafts ran for 11 years, 10 hours a day, without serious interruption. Oil was fed to the shaft before closing down for the night, to prevent rusting. The wear of the babbitted bearings in 11 years was about  $\frac{1}{4}$  in., and of the shaft nil.

**Acheson's "Deflocculated" Graphite.** (*Trans. A. I. E. E.*, 1907; *Eng. News*, Aug. 1, 1907.) — In 1906, Mr. E. G. Acheson discovered a process of producing a fine, pure, unctuous graphite in the electric furnace. He calls it deflocculated graphite. By treating this graphite in the disintegrated form with a water solution of tannin, the amount of tannin being from 3% to 6% of the weight of the graphite treated, he found that it would be retained in suspension in water, and that it was in such a fine state of subdivision that a large part of it would run through the finest filter paper, the filtrate being an intensely black liquid in which the graphite would remain suspended for months. The addition of a minute quantity of hydrochloric acid causes the graphite to flocculate and group together so that it will no longer flow through filter paper. The same effect has been obtained with alumina, clay, lampblack and siloxicon, by treatment with tannin. The graphite thus suspended in water, known as "*aquedag*," has been successfully used as a lubricant for journals with sight-feed and with chain-feed oilers. It also prevents rust in iron and steel. The deflocculated graphite has also been suspended in oil, in a dehydrated condition, making an excellent lubricant known as "*oildag*." Tests by Prof. C. H. Benjamin of oil with 0.5% of graphite showed that it had a lower coefficient of friction than the oil alone.

### SOLID LUBRICANTS.

**Graphite** in a condition of powder and used as a *solid lubricant*, so called, to distinguish it from a liquid lubricant, has been found to do well where the latter has failed.

Rennie, in 1829, says: "Graphite lessened friction in all cases where it was used." General Morin, at a later date, concluded from experiments that it could be used with advantage under heavy pressures: and Prof. Thurston found it well adapted for use under both light and heavy pressures when mixed with certain oils. It is especially valuable to prevent abrasion and cutting under heavy loads and at low velocities.

For comparative tests of various oils with and without graphite, see paper on lubrication and lubricants, by C. F. Mabery, *Jour. A. S. M. E.*, Feb., 1910.

**Soapstone**, also called talc and steatite, in the form of powder and mixed with oil or fat, is sometimes used as a lubricant. Graphite or soapstone, mixed with soap, is used on surfaces of wood working against either iron or wood.

**Metaline** is a solid compound, usually containing graphite, made in the form of small cylinders which are fitted permanently into holes drilled in the surface of the bearing. The bearing thus fitted runs without any other lubrication.

Bushings fitted with graphite packed into grooves are made by the Graphite Lubricating Co., Bound Brook, N. J.



## THE FOUNDRY.

(See also Cast-iron, pp. 437 to 445, and Fans and Blowers, pp. 653 to 673.)

## Cupola Practice.

The following table and the notes accompanying it are condensed from an article by Simpson Bolland in *Am. Mach.*, June 30, 1892:

Diam. of lining, in.....	36	48	54	60	66	72	84
Height to char'g door, ft. . .	12	13	14	15	15	16	16
Fuel used in bed, lbs.....	840	1380	1650	1920	2190	2460	3000
First charge of iron, lbs....	2520	4140	4950	5760	6570	7380	9000
Other fuel charges, lbs.....	302	554	680	806	932	1058	1310
Other iron charges, lbs.....	2718	4986	6120	7254	8388	9522	11,790
Diam. blast pipe, in.....	14	18	20	22	22	24	26
No. of 6-in. round tuyeres..	3.7	6.8	10.7	13.7	15.4	19	31
Equiv. No. flat tuyeres....	4	6	8	8	8	10	16
Width of flat tuyeres, in....	2	2.5	2.5	3	3	3	3.5
Height of flat tuyeres, in...	13.5	13.5	15.5	16.5	18.5	18.5	16
Blast pressure, oz.....	8	12	14	14	14	16	16
Size of Root blower, No.....	2	4	4	5	5	6	7
Revs. per min.....	241	212	277	192	240	163	160
Engine for blower, H.P.....	2.5	10	14	18 <sup>1</sup> / <sub>2</sub>	23	33	47
Sturtevant blower, No.....	4	6	7	8	8	9	10
Engine for blower, H.P.....	3	9 <sup>3</sup> / <sub>4</sub>	16	22	22	35	48
Melting cap., lbs. per hr....	4820	10,760	13,850	16,940	21,200	26,070	37,530

Mr. Bolland says that the melting capacities in the table are not supposed to be all that can be melted in the hour by some of the best cupolas, but are simply the amounts which a common cupola under ordinary circumstances may be expected to melt in the time specified.

By height of cupola is meant the distance from the base to the bottom side of the charging door. The distance from the sand-bed, after it has been formed at the bottom of the cupola, up to the under side of the tuyeres is taken at 10 ins. in all cases.

All the amounts for fuel are based upon a bottom of 10 ins. deep. The quantity of fuel used on the bed is more in proportion as the depth is increased, and less when it is made shallower.

The amount of fuel required on the bed is based on the supposition that the cupola is a straight one all through, and that the bottom is 10 ins. deep. If the bottom be more, as in those of the Colliau type, then additional fuel will be needed.

*First Charge of Iron.* — The amounts given are safe figures to work upon in every instance, yet it will always be in order, after proving the ability of the bed to carry the load quoted, to make a slow and gradual increase of the load until it is fully demonstrated just how much burden the bed will carry.

*Succeeding Charges of Fuel and Iron.* — The highest proportions are not favored, for the simple reason that successful melting with any greater proportion of iron to fuel is not the rule, but, rather, the exception.

*Diameter of Main Blast-pipe.* — The sizes given are of sufficient area for all lengths up to 100 feet.

*Tuyeres.* — Any arrangement or disposition of tuyeres may be made, which shall answer in their totality to the areas given in the table. On no consideration must the tuyere area be reduced; thus, an 84-inch cupola must have tuyere area equal to 31 pipes 6 ins. diam., or 16 flat tuyeres 16 × 3<sup>1</sup>/<sub>2</sub> ins. The tuyeres should be arranged in such a manner as will concentrate the fire at the melting-point into the smallest possible compass, so that the metal in fusion will have less space to traverse while exposed to the oxidizing influence of the blast.

To accomplish this, recourse has been had to the placing of additional rows of tuyeres in some instances — the "Stewart rapid cupola" having three rows, and the "Colliau cupola furnace" having two rows, of tuyeres.

[Cupolas as large as 84 inches in diameter are now (1906) built without boshes. The most recent development with this size cupola is to place a center tuyere in the bottom discharging air vertically upwards.]

**Blast-pressure.** — About 30,000 cu. ft. of air are consumed in melting a ton of iron, which would weigh about 2400 pounds, or more than both iron and fuel. When the proper quantity of air is supplied, the combustion of the fuel is perfect, and carbonic-acid gas is the result. When the supply of air is insufficient, the combustion is imperfect, and carbonic-oxide gas is the result. The amount of heat evolved in these two cases is as 15 to 4½, showing a loss of over two-thirds of the heat by imperfect combustion. [Combustion is never perfect in the cupola except near the tuyeres. The CO<sub>2</sub> formed by complete combustion is largely reduced to CO in passing through the hot coke above the fusion zone.]

It is not always true that we obtain the most rapid melting when we are forcing into the cupola the largest quantity of air. Too much air absorbs heat, reduces the temperature, and retards combustion, and the fire in the cupola may be extinguished with too much blast.

**Slag in Cupolas.** — A certain amount of slag is necessary to protect the molten iron which has fallen to the bottom from the action of the blast; if it was not there, the iron would suffer from decarbonization.

When slag from any cause forms in too great abundance, it should be led away by inserting a hole a little below the tuyeres, through which it will find its way as the iron rises in the bottom.

With clean iron and fuel, slag seldom forms to any appreciable extent in small heats; but when the cupola is to be taxed to its utmost capacity it is then incumbent on the melter to flux the charges all through the heat, carrying it away in the manner directed.

The best flux for this purpose is the chips from a white-marble yard. About 6 pounds to the ton of iron will give good results when all is clean. [Fluor-spar is now largely used as a flux.]

When fuel is bad, or iron is dirty, or both together, it becomes imperative that the slag be kept running all the time.

**Fuel for Cupolas.** — The best fuel for melting iron is coke, because it requires less blast, makes hotter iron, and melts faster than coal. When coal must be used, care should be exercised in its selection. All anthracites which are bright, black, hard, and free from slate, will melt iron admirably. For the best results, small cupolas should be charged with the size called "egg," a still larger grade for medium-sized cupolas, and what is called "lump" will answer for all large cupolas, when care is taken to pack it carefully on the charges.

**Melting Capacity of Different Cupolas.** — The following figures are given by W. B. Snow, in *The Foundry*, Aug., 1908, showing the records of capacity and the blast pressure of several cupolas:

Diam. of lining,											
ins. . . . .	44	44	47	49	54	54	54	60	60	60	74
Tons per hour..	6.7	7.3	8.4	9.1	7.7	8.8	10.2	12.4	14.8	13.8	13.0
Pressure, oz. per											
sq. in. . . . .	12.9	16.4	17.5	11.8	13.6	11.0	20.8	15.5	16.8	12.6	8.7

From plotted diagrams of records of 46 tests of different cupolas the following figures are obtained:

Diam. of lining, ins. . . . .	30	36	42	48	54	60	66	72
Max. tons per hour . . . . .	3	5	7.3	9.5	12	15	18	21
Avg. " " " . . . . .	2.5	4	5.5	7.5	9	11	13	16
Max. pressure, oz. . . . .	11	12	13.5	14	14.6	15.2	15.7	16

For a given cupola and blower the melting rate increases as the square root of the pressure. A cupola melting 9 tons per hour with 10 ounces pressure will melt about 10 tons with 12.5 ounces, and 11 tons with 15 ounces. The power required varies as the cube of the melting rate, so that it would require  $(11/9)^3 = 1.82$  times as much power for 11 tons as for 9 tons. Hence the advantage of large cupolas and blowers with light pressures.

**Charging a Cupola.** — Chas. A. Smith (*Am. Mach.*, Feb. 12, 1891) gives the following: A 28-in. cupola should have from 300 to 400 lbs. of coke on bottom bed; a 36-in. cupola, 700 to 800 lbs.; a 48-in. cupola, 1500 lbs.; and a 60-in. cupola should have one ton of fuel on bottom bed.

To every pound of fuel on the bed, three, and sometimes four pounds of metal can be added with safety, if the cupola has proper blast; in after-charges, to every pound of fuel add 8 to 10 pounds of metal; any well-constructed cupola will stand ten.

F. P. Wolcott (*Am. Mach.*, Mar. 5, 1891) gives the following as the practice of the Colwell Iron-works, Carteret, N. J.: "We melt daily from twenty to forty tons of iron, with an average of 11.2 pounds of iron to one of fuel. In a 36-in. cupola seven to nine pounds is good melting, but in a cupola that lines up 48 to 60 inches, anything less than nine pounds shows a defect in arrangement of tuyeres or strength of blast, or in charging up."

"The Molder's Text-book," by Thos. D. West, gives forty-six reports in tabular form of cupola practice in thirty States, reaching from Maine to Oregon.

**Improvement of Cupola Practice.** — The following records are given by J. R. Fortune and H. S. Wells (*Proc. A. S. M. E.*, Mar., 1908) showing how ordinary cupola practice may be improved by making a few changes. The cupola is 13 ft. 4 in. in height from the top of the sand bottom to the charging door, and of three diameters, 50 in. for the first 3 ft. 6 in., then 54 in. for the next 2 ft. 4 in., then 60 in. to the top. When driven with a No. 8 Sturtevant blower, the maximum melting rate, from iron down to blast off, was 8.5 tons per hour. A No. 11 high-pressure blower was then installed. Test No. 1 in the table below gives the result with cupola charges as follows in pounds: Bed, 590 coke, followed by 826 coke, 2000 iron; 400 coke, 2000 iron; 300 coke, 2000 iron; and thereafter all charges were 200 coke, 2000 iron. The time between starting fire and starting blast was 2 hr. 30 min., and the time from blast on to iron down, 11 min. The melting rate, tons per hour, is figured for the time from iron down to blast off. The tuyeres were eight rectangular openings 11¼ in. high and of a total area of 1/9.02 of the area of the 54-in. circle.

No. of Test.	1	2	3	4	5	6	7	8	9	10
Total tons...	22.7	24.	22.15	24.25	24.25	22.65	24.	20.30	23.85	22.35
Tons per hr..	9.45	8.88	8.86	9.15	9.66	10.24	10.43	10.91	11.35	11.17
Lbs. per min*	19.81	18.61	18.55	19.17	20.25	21.44	21.82	22.95	23.77	23.39
Iron ÷ coke†	7.54	7.40	7.28	8.58	8.94	8.71	9.02	9.02	10.02	9.49
Blast, oz.....	11.60	10.63	10.00	9.47	9.80	9.86	10.00	10.13	10.55	10.55

\* Per sq. ft. cupola area at 54 in. diam. from iron down to blast off.

† Including bed.

The tuyeres were then enlarged, making their area 1/5.98 of the cupola (54 in.) area, and the results are shown in tests No. 2 and 3 of the table. The iron was too hot, and the coke charge was decreased to a ratio of 1/13.33 instead of 1/10, the bed of coke being increased. The result, test No. 4, was an increased rate of melting, a decrease in the amount of coke, and a decrease in the blast pressure. Tests 5, 6, 7, 8 and 9 were then made, the coke being decreased, while the blast pressure was increased, resulting in a decided increase in the melting speed. In tests 5, 6 and 7 the iron layer was 13.33 times the weight of the coke layer; in test 8, 14.28 times; and in test 9, 15.38 times. In test 9 it was noticed that the iron was not at the proper temperature, and in test 10 the coke layer was increased to a ratio of 1 to 14.28 without altering the blast pressure; this resulted in a decreased melt per hour. It has been found that a coke charge of 150 lbs. to 2000 lbs. of iron, with a blast pressure of 10.5 ounces, results in a melt of 11.5 tons per hour, the iron coming down at the proper temperature.

An excess of coke decreases the melting rate. Iron in the cupola is melted in a fixed zone, the first charge of iron above the bed being melted by burning coke in the bed. As this iron is melted, the charge of coke above it descends and restores to the bed the amount which has been burned away. If there is too much coke in the charge, the iron is held above the melting zone, and the excess coke must be burned away before it can be melted, and this of course decreases the economy and the melting speed.



**Cupola Charges in Stove-foundries.** (*Iron Age*, April 14, 1892.) — No two cupolas are charged exactly the same. The amount of fuel on the bed or between the charges differs, while varying amounts of iron are used in the charges. Below will be found charging-lists from some of the prominent stove-foundries in the country:

<p><b>A</b>—Bed of fuel, coke..... 1,500          First charge of iron..... 5,000          All other charges of iron.... 1,000          First and second charges of coke, each..... 200</p>	<p>lbs.   lbs.   lbs.   lbs.</p>	<p>Four next charges of coke, each..... 150          Six next charges of coke, each..... 120          Nineteen next charges of coke, each..... 100</p>	<p>lbs.   lbs.   lbs.   lbs.</p>
---	--	--	--

Thus for a melt of 18 tons there would be 5120 lbs. of coke used, giving a ratio of 7 to 1. Increase the amount of iron melted to 24 tons, and a ratio of 8 pounds of iron to 1 of coal is obtained.

<p><b>B</b>—Bed of fuel, coke..... 1,600          First charge of iron..... 1,800          First charge of fuel..... 150          All other charges of iron, each..... 1,000</p>	<p>lbs.   lbs.   lbs.   lbs.</p>	<p>Second and third charges of fuel..... 130          All other charges of fuel, each..... 100</p>	<p>lbs.   lbs.   lbs.   lbs.</p>
--	--	--	--

For an 18-ton melt 5060 lbs. of coke would be necessary, giving a ratio of 7.1 lbs. of iron to 1 pound of coke.

<p><b>C</b>—Bed of fuel, coke..... 1,600          First charge of iron..... 4,000          First and second charges of coke..... 200</p>	<p>lbs.   lbs.   lbs.   lbs.</p>	<p>All other charges of iron..... 2,000          All other charges of coke..... 150</p>	<p>lbs.   lbs.   lbs.   lbs.</p>
--	--	---	--

In a melt of 18 tons 4100 lbs. of coke would be used, or a ratio of 8.5 to 1.

<p><b>D</b>—Bed of fuel, coke..... 1,800          First charge of iron..... 5,600</p>	<p>lbs.   lbs.   lbs.   lbs.</p>	<p>All charges of coke, each..... 200          All other charges of iron..... 2,900</p>	<p>lbs.   lbs.   lbs.   lbs.</p>
---	--	---	--

In a melt of 18 tons, 3900 lbs. of fuel would be used, giving a ratio of 9.4 pounds of iron to 1 of coke. Very high, indeed, for stove-plate.

<p><b>E</b>—Bed of fuel, coal..... 1,900          First charge of iron..... 5,000          First charge of coal..... 200</p>	<p>lbs.   lbs.   lbs.   lbs.</p>	<p>All other charges of iron, each..... 2,000          All other charges of coal, each..... 175</p>	<p>lbs.   lbs.   lbs.   lbs.</p>
--	--	---	--

In a melt of 18 tons 4700 lbs. of coal would be used, giving a ratio of 7.7 lbs. of iron to 1 lb. of coal.

These are sufficient to demonstrate the varying practices existing among different stove-foundries. In all these places the iron was proper for stove-plate purposes, and apparently there was little or no difference in the kind of work in the sand at the different foundries.

**Foundry Blower Practice.** (W. B. Snow, *Trans. A. S. M. E.*, 1907.) — The velocity of air produced by a blower is expressed by the

formula  $V = \sqrt{2gp/d}$ . If  $p$ , the pressure, is taken in ounces per sq. in., and  $d$ , the density, in pounds per cu. ft. of dry air at 50° and atmospheric pressure of 14.69 lbs. or 235 ounces, = 0.77884 lb., the formula reduces to  $V = \sqrt{1,746,700 p/(235 + p)}$ , no allowance being made for change of temperature during discharge. From this formula the following figures are obtained.  $Q$  = volume discharged per min. through an orifice of 1 sq. ft. effective area, H.P. = horse-power required to move the given volume under the given conditions,  $p$  = pressure in ounces per sq. in.

$p$	$Q$	H.P.	$p$	$Q$	H.P.	$p$	$Q$	H.P.	$p$	$Q$	H.P.
1	35.85	0.00978	6	86.89	0.1422	11	116.45	0.3493	16	139.03	0.6067
2	50.59	0.02759	7	93.66	0.1788	12	121.38	0.3972	17	143.03	0.6631
3	61.83	0.05058	8	99.92	0.2180	13	126.06	0.4470	18	146.88	0.7211
4	71.24	0.07771	9	105.76	0.2596	14	130.57	0.4986	19	150.61	0.7804
5	79.48	0.1084	10	111.25	0.3034	15	134.89	0.5518	20	154.22	0.8412

The greatest effective area over which a fan will maintain the maximum velocity of discharge is known as the "capacity area" or "square inches of blast." As originally established by Sturtevant it is represented by  $DW/3$ ,  $D$  = diam. of wheel in ins.,  $W$  = width of wheel at circumference,

in inches. For the ordinary type of fan at constant speed maximum efficiency and power are secured at or near the capacity area; the power per unit of volume and the pressure decrease as the discharge area and volume increase; with closed outlet the power is approximately one-third of that at capacity area.

The following table is calculated on these bases: Capacity area per inch of width at periphery of wheel =  $\frac{1}{3}$  of diam. Air, 50° F. Velocity of discharge = circumferential speed of the wheel. Power = double the theoretical. In rotary positive blowers, as well as in fans, the velocity and the volume vary as the number of revolutions, the pressure varies as the square, and the power as the cube of the number of revolutions. In the fan, however, increase of pressure can be had only by increasing the revolutions, while in the rotary blower a great range of pressure is obtainable with constant speed by merely varying the resistance. With a rotary blower at constant speed, theoretically, and disregarding the effect of changes in temperature and density, the volume is constant; the velocity varies inversely as the effective outlet area; the pressure varies inversely as the square of the outlet area, hence as the square of the velocity; and the power varies directly as the pressure. The maximum power is required when a fan discharges against the least, and when a rotary blower discharges against the greatest resistance.

PERFORMANCE OF CUPOLA FAN BLOWERS AT CAPACITY AREA PER INCH OF PERIPHERAL WIDTH.

Diam. of Wheel, ins.	Item.	Total Pressure in Ounces per Square Inch.										
		6	7	8	9	10	11	12	13	14	15	16
18	r.p.m.	2660.0	2860.0	3050.0	3230.0	3400.0	3560.0	3710.0	3850.0	3990.0	4120.0	4250.0
	cu. ft.	520.0	560.0	600.0	640.0	670.0	700.0	730.0	760.0	780.0	810.0	830.0
	h.p.	1.7	2.1	2.6	3.1	3.6	4.2	4.8	5.4	6.0	6.6	7.3
24	r.p.m.	2006.0	2150.0	2290.0	2420.0	2550.0	2670.0	2780.0	2890.0	2990.0	3090.0	3190.0
	cu. ft.	700.0	750.0	800.0	850.0	890.0	930.0	970.0	1010.0	1040.0	1080.0	1110.0
	h.p.	2.3	2.9	3.5	4.2	4.9	5.6	6.4	7.1	8.0	8.8	9.7
30	r.p.m.	1590.0	1720.0	1830.0	1940.0	2040.0	2140.0	2230.0	2310.0	2390.0	2470.0	2550.0
	cu. ft.	870.0	940.0	1000.0	1060.0	1110.0	1160.0	1210.0	1260.0	1310.0	1350.0	1390.0
	h.p.	2.8	3.6	4.4	5.2	6.1	7.0	7.9	8.9	10.0	11.0	12.1
36	r.p.m.	1330.0	1430.0	1530.0	1620.0	1700.0	1780.0	1850.0	1930.0	2000.0	2060.0	2120.0
	cu. ft.	1040.0	1120.0	1200.0	1270.0	1340.0	1400.0	1460.0	1510.0	1570.0	1620.0	1670.0
	h.p.	3.4	4.3	5.2	6.2	7.3	8.4	9.5	10.7	11.9	13.2	14.5
42	r.p.m.	1140.0	1230.0	1310.0	1380.0	1460.0	1530.0	1590.0	1650.0	1710.0	1770.0	1820.0
	cu. ft.	1220.0	1310.0	1400.0	1480.0	1560.0	1630.0	1700.0	1770.0	1830.0	1890.0	1950.0
	h.p.	3.9	5.0	6.1	7.3	8.5	9.8	11.1	12.5	13.9	15.4	17.0
48	r.p.m.	1000.0	1070.0	1150.0	1210.0	1270.0	1330.0	1390.0	1450.0	1500.0	1550.0	1590.0
	cu. ft.	1390.0	1500.0	1600.0	1690.0	1780.0	1860.0	1940.0	2020.0	2090.0	2160.0	2230.0
	h.p.	4.5	5.7	7.0	8.3	9.7	11.2	12.7	14.3	15.9	17.7	21.0

The air supply required by a cupola varies with the melting ratio, the density of the charges, and the incidental leakage. Average practice is represented by the following:

Lbs. iron per lb. coke . . . . .	6	7	8	9	10
Cu. ft. air per ton of iron . . . . .	33,000	31,000	29,000	27,000	25,000

It is customary to provide blower capacity on a basis of 30,000 cu. ft., which corresponds to 75 to 80% of the chemical requirements for complete combustion with average coke, and a melting ratio of 7.5 to 1.

In comparative tests with a 54-inch lining cupola under identical conditions as to contents, alternately run with a No. 10 Sturtevant fan and a 33 cu. ft. Connersville rotary, with the fan the pressure varied between 12½ and 14⅓ ounces in the wind box, the net power from 25 to 38.5 H.P., while with the rotary blower the pressure varied between 10½ and 25 ounces, and the power between 19 and 45 H.P. With the fan 28.84 tons

were melted in 3.77 hours, or 7.65 tons per hour, while with the rotary blower 2.82 hours were required to melt 31.5 tons, an hourly rate of 10.6 tons, an increase of nearly 40 per cent in output. This reduces to a net input of 4.09 H.P. per ton melted per hour with the fan, and 2.98 H.P. with the rotary blower; an apparent advantage of 27% in favor of the rotary. Had the rotary been of smaller capacity such excessive pressures would not have been necessary, the power would have been decreased, and the duration of the heat prolonged, with probable decrease in the H.P. hours per ton. Had the fan been run at higher speed the H.P. would have increased, the time decreased and the power per ton per hour would have more closely approached that required by the rotary blower.

Theoretically, for otherwise constant conditions, the following relations hold for cupolas and melting rates within the range of practical operation:

For a given cupola:	For a given melting rate:	For a given volume:
$M \propto V, \sqrt{P}$ , or $\sqrt[3]{H.P.}$	$V \propto 1 \div D^2$	$M \propto D$
$V \propto M$	$P \propto d$	For a given cupola
$P \propto V^2$	H.P. $\propto P$ or $1 \div D^4$	$E \propto M^2$ , or $P$
H.P. $\propto M^3$ or $\sqrt{P^3}$	$E \propto M, P$ , or $1 \div D^4$	Duration of heat
		$\propto 1 \div \sqrt{P}$

$M$  = melting rate;  $V$  = volume;  $P$  = pressure; H.P. = horse-power;  $D$  = diam. of lining;  $E$  = operating efficiency = power per ton per hour;  $d$  = depth of the charge;  $\propto$ , varies as.

These relations might be the source of formulæ for practical use were it possible to establish accurate coefficients. But the variety in cupolas, tuyere proportions, character of fuel and iron, and difference in charging practice are bewildering and discouraging. Maximum efficiency in a given case can only be assured after direct experiment. Something short of the maximum is usually accepted in ignorance of the ultimate possibilities.

The actual melting range of a cupola is ordinarily between 0.6 and 0.75 ton per hour per sq. ft. of cross section. The limits of air supply per minute per sq. ft. are roughly 2500 and 4000 cu. ft. The possible power required varies even more widely, ranging from 1.5 to 3.75 H.P. per sq. ft., corresponding to 2.5 and 5 H.P. per ton per hour for the melting rates specified. The power may be roughly calculated, from the theoretical requirement of 0.27 H.P. to deliver 1000 cu. ft. per minute against 1 oz. pressure. The power increases directly with the pressure, and depends also on the efficiency of the blower. Current practice can only be expressed between limits as in the following table.

RANGE OF PERFORMANCE OF CUPOLA BLOWERS.

Diameter inside Lining, in.	Capacity per Hour, tons.	Pressure per sq. in., oz.	Volume of Air per min., cu. ft.	Horse-power.
18.....	0.25-0.5	5-7	150-300	0.5-1.5
24.....	1.00-1.5	7-9	600-900	2.0-6.0
30.....	2.00-3.5	8-11	1,200-2,000	5.0-15.0
36.....	4.00-5.0	8-12	2,200-2,800	10.0-23.0
42.....	5.00-7.0	8-13	2,700-3,700	12.0-32.0
48.....	8.00-10.0	8-13	4,000-5,000	18.0-45.0
54.....	9.00-12.0	9-14	4,500-6,000	22.0-60.0
60.....	12.00-15.0	9-14	6,000-7,500	30.0-75.0
66.....	14.00-18.0	9-15	7,000-9,000	35.0-90.0
72.....	17.00-21.0	10-15	8,500-10,500	45.0-110.0
78.....	19.00-24.0	10-16	9,500-12,000	52.0-139.0
84.....	21.00-27.0	10-16	10,500-13,500	60.0-150.0

**Results of Increased Driving.** (Erie City Iron-works, 1891.)—May-Dec., 1890: 60-in. cupola, 100 tons clean castings a week, melting 8 tons per hour; iron per pound of fuel,  $7\frac{1}{2}$  lbs.; per cent weight of good castings to iron charged,  $75\frac{3}{4}$ . Jan.-May, 1891: Increased rate of melting to  $11\frac{1}{2}$  tons per hour; iron per lb. fuel,  $9\frac{1}{2}$ ; per cent weight of good castings, 75; one week,  $13\frac{1}{4}$  tons per hour, 10.3 lbs. iron per lb. fuel; per cent weight of good castings, 75.3. The increase was made by putting in an additional row of tuyeres and using stronger blast, 14 ounces. Coke was used as fuel. (W. O. Webber, *Trans. A. S. M. E.*, xii, 1045.)



**Power Required for a Cupola Fan.** (Thos. D. West, *The Foundry*, April, 1904.) — The power required when a fan is connected with a cupola depends on the length and diameter of the piping, the number of bends, valves, etc., and on the resistance to the passage of blast through the cupola. The approximate power required in everyday practice is the difference between the power required to run the fan with the outlet open and with it closed. Another rule is to take 75% of the maximum power or that with the outlet open. A fan driving a cupola 66 ins. diam., 1800 r.p.m., driven by an electric motor required horse-power and gave pressures as follows: Outlet open, 146.6; outlet closed, 37.2, pressure 15 oz.; attached to cupola, with no fuel in it, 120.5, 5 oz.; after kindling and coke had been fired, 101.0, 10 oz.; during the run 70.8 to 76.7, 11 to 13 oz., the variations being due to changes in the resistances to the passage of the blast.

**Utilization of Cupola Gases.** — Jules De Clercy, in a paper read before the Amer. Foundrymen's Assn., advises the return of a portion of the gases from the upper part of the charge to the tuyeres, and thus utilizing the carbon monoxide they contain. He says that A. Baillet has thereby succeeded in melting 15 lbs. of iron per lb. of coke, and at the same time obtained a greater melting speed and a superior quality of castings.

**Loss in Melting Iron in Cupolas.** — G. O. Vair, *Am. Mach.*, March 5, 1891, gives a record of a 45-in. Colliau cupola as follows:

	Ratio of fuel to iron, 1 to 7.42.	
Good castings.....		21,314 lbs.
New scrap.....		3,005 "
Millings.....		200 "
Loss of metal.....		1,481 "

Amount melted..... 26,000 lbs.  
Loss of metal, 5.69%. Ratio of loss, 1 to 17.55.

**Use of Softeners in Foundry Practice.** (W. Graham, *Iron Age*, June 27, 1889.) — In the foundry the problem is to have the right proportions of combined and graphitic carbon in the resulting casting; this is done by getting the proper proportion of silicon. The variations in the proportions of silicon afford a reliable and inexpensive means of producing a cast iron of any required mechanical character which is possible with the material employed. In this way, by mixing suitable irons in the right proportions, a required grade of casting can be made more cheaply than by using irons in which the necessary proportions are already found.

Hard irons, mottled and white irons, and even steel scrap, all containing low percentages of silicon and high percentages of combined carbon, could be employed if an iron having a large amount of silicon were mixed with them in sufficient amount. This would bring the silicon to the proper proportion and would cause the combined carbon to be forced into the graphitic state, and the resulting casting would be soft. High-silicon irons used in this way are called "softeners."

Mr. Keep found that more silicon is lost during the remelting of pig of over 10% silicon than in remelting pig iron of lower percentages of silicon. He also points out the possible disadvantage of using ferro-silicons containing as high a percentage of combined carbon as 0.70% to overcome the bad effects of combined carbon in other irons.

The Scotch irons generally contain much more phosphorus than is desired in irons to be employed in making the strongest castings. It is a mistake to mix with strong low-phosphorus irons an iron that would increase the amount of phosphorus for the sake of adding softening qualities, when softness can be produced by mixing irons of the same low phosphorus.

(For further discussion of the influence of silicon, see pages 438 and 447.)

**Weakness of Large Castings.** (W. A. Bole, *Trans. A. S. M. E.*, 1907.) — Thin castings, by virtue of their more rapid cooling, are almost certain to be stronger per unit section than would be the case if the same metal were poured into larger and heavier shapes. Many large iron castings are of questionable strength, because of internal strains and lack of harmony between their elements, even though the casting is poured out of iron of the best quality. This may be due to lack of experience on the part of

the designer, especially in the cooling and shrinking of the various parts of a large casting after being poured.

Castings are often designed with a useless multiplicity of ribs, walls, gussets, brackets, etc., which, by their asynchronous cooling and their inharmonious shrinkage and contraction, may entirely defeat the intention of the designer.

There are some castings which, by virtue of their shapes, can be specially treated by the foundryman, and artificial cooling of certain critical parts may be effected in order to compel such parts to cool more rapidly than they would naturally do, and the strength of the casting may by such means be beneficially affected. As for instance in the case of a fly-wheel with heavy rim but comparatively light arms and hub; it may be beneficial to remove the flask and expose the rim to the air so as to hasten its natural rate of cooling, while the arms and hub are still kept muffled up in the sand of the mold and their cooling retarded as much as possible.

Large fillets are often highly detrimental to good results. Where two walls meet and intersect, as in the shape of a *T*, if a large fillet is swept at the juncture, there will be a pool of liquid metal at this point which will remain liquid for a longer time than either wall, the result being a void, or "draw," at the juncture point.

Risers and sink heads should often be employed on iron castings. In large iron-foundry work interior cavities may exist without detection, and some of these may be avoided by the use of suitable feeding devices, risers and sink heads.

Specimens from a casting having at one point a tensile strength as high as 30,250 lbs. per sq. in. have shown as low as 20,500 in another and heavier section. Large sections cannot be cast to yield the high strength of specimen test pieces cast in smaller sections.

The paper describes a successful method of artificial cooling, by means of a coil of pipe with flowing water, of portions of molds containing cylinder heads with ports cast in them. Before adopting this method the internal ribs in these castings always cracked by contraction.

**Shrinkage of Castings.**—The allowance necessary for shrinkage varies for different kinds of metal, and the different conditions under which they are cast. For castings where the thickness runs about one inch, cast under ordinary conditions, the following allowance can be made:

For cast iron,	1/8	inch	per	foot.	For zinc,	5/16	inch	per	foot.
" brass,	3/16	"	"	"	" tin,	1/12	"	"	"
" steel,	1/4	"	"	"	" aluminum,	3/16	"	"	"
" mal. iron,	1/8	"	"	"	" britannia,	1/32	"	"	"

Thicker castings, under the same conditions, will shrink less, and thinner ones more, than this standard. The quality of the material and the manner of molding and cooling will also make a difference. (See also Shrinkage of Cast Iron, page 447.)

Mr. Keep (*Trans. A. S. M. E.*, vol. xvi) gives the following "approximate key for regulating foundry mixtures" so as to produce a shrinkage of 1/8 in. per ft. in castings of different sections:

Size of casting . . . . .	1/2	1	2	3	4	in. sq.
Silicon required, per cent . . . . .	3.25	2.75	2.25	1.75	1.25	per cent.
Shrinkage of a 1/2-in. test-bar . .	0.125	.135	.145	.155	.165	in per. ft.

**Growth of Cast Iron by Heating.** (*Proc. I. and S. Inst.*, 1909.)—Investigations by Profs. Rugey and Carpenter confirm Mr. Outerbridge's experiments. (See page 449) They found: 1. Heating white iron causes it to become gray, and it expands more than sufficient to overcome the original shrinkage. 2. Iron when heated increases in weight, probably due to absorption of oxygen. 3. The change in size due to heating is not only a molecular change, but also a chemical one. 4. The growth of one bar was shown to be due to penetration of gases. When heated in vacuo it contracted.

**Hard Iron due to Excessive Silicon.**—W. J. Keep in *Jour. Am. Foundrymen's Assn.*, Feb., 1898, reports a case of hard iron containing graphite, 3.04; combined C, 0.10; Si, 3.97; P, 0.61; S, 0.05; Mn, 0.56. He says: For stove plate and light hardware castings it is an advantage to have Si as high as 3.50. When it is much above that the surface of the castings often become very hard, though the center will be very soft.

The surface of heavier parts of a casting having 3.97 Si will be harder than the surface of thinner parts. Ordinarily if a casting is hard an increase of silicon softens it, but after reaching 3.00 or 3.50 per cent, silicon hardens a casting.

**Ferro-Alloys for Foundry Use.** E. Houghton (*Iron Tr. Rev.*, Oct. 24, 1907.) — The objects of the use of ferro-alloys in the foundry are: 1, to act as deoxidizers and desulphurizers, the added element remaining only in small quantities in the finished casting; 2, to alter the composition of the casting and so to control its mechanical properties. Some of these alloys are made in the blast furnace, but the purest grades are made in the electric furnace. The following table shows the range of composition of blast furnace alloys made by the Darwen & Mostyn Iron Co. All of these alloys may be made of purer quality in the electric furnace.

	Ferro-Mn.	Spiegel-eisen.	Silicon Spiegel.	Ferro-sil.	Ferro-phos.	Ferro-Chrome.
Mn.....	41.5- 87.9	9.25-29.75	17.50-20.87	1.17- 2.20	3.00- 5.90	1.55- 2.30
Si.....	0.10- 0.63	0.42- 0.95	9.45-14.23	8.10-17.00	0.50- 0.84	0.13- 0.36
P.....	0.09- 0.20	0.06- 0.09	0.07- 0.10	0.06- 0.08	15.71-20.50	0.04- 0.07
C.....	5.62- 7.00	3.94- 5.20	1.05- 1.89	0.90- 1.75	0.27- 0.30	5.34- 7.12
S.....	nil	nil-trace	nil	0.02- 0.05	0.16- 0.33	Cr, 13.50-41.39

The following are typical analyses of other alloys made in the electric furnace:

	Si	Fe	Mn	Al	Ca	Mg	C	S	P	Ti
Ferro-titanium.....	1.21	.....	.....	0.30	.....	.....	3.28	0.03	0.02	53.0
Ferro-aluminum-silicide.....	45.65	44.15	tr.	9.45	nil	nil	0.55	0.01	0.03	.....
Ferro-calcium-silicide.....	69.80	11.15	0.22	2.55	15.05	0.26	1.14	0.01	0.04	.....

Ferro-aluminum, Al, 5, 10 and 20%. Metallic manganese, Mn, 95 to 98; Fe, 2 to 4; C, under 5. Do. refined, Mn, 99; Fe, 1; C, 0.

**Dangerous Ferro-silicon.** — Phosphoretted and arseniuretted hydrogen, highly poisonous gases, are said to be disengaged in a humid atmosphere from ferro-silicon containing between 30 and 40% and between 47 and 65% of Si, and there is therefore danger in transporting it in passenger steamships. A French commission has recommended the abandonment of the manufacture of FeSi of these critical percentages. (*La Lumiere Electrique*, Dec. 11, 1909. *Elec. Rev.*, Feb. 26, 1910.)

**Quality of Foundry Coke.** (R. Moldenke, *Trans. A. S. M. E.*, 1907.) — Usually the sulphur, ash and fixed carbon are sufficient to give a fair idea of the value of coke, apart from its physical structure, specific gravity, etc. The advent of by-product coke will necessitate closer attention to moisture. Beehive coke, when shipped in open cars, may, through inattention, cause the purchase of from 6 to 10 per cent of water at coke prices.

Concerning sulphur, very hot running of the cupola results in less sulphur in the iron. In good coke, the amount of S should not exceed 1.2 per cent; but, unfortunately, the percentage often runs as high as 2.00. If the coke has a good structure, an average specific gravity, not over 11 per cent of ash and over 86 per cent of fixed carbon, it does not matter much whether it be of the "72 hour" or "24 hour" variety. Departure from the normal composition of a coke of any particular region should place the foundryman on his guard at once, and sometimes the plentiful use of limestone at the right moment may save many castings.

**Castings made in Permanent Cast-Iron Molds.** — E. A. Custer, in a paper before the Am. Foundrymen's Assn. (*Eng. News*, May 27, 1909), describes the method of making castings in iron molds, and the quality of these castings. Very heavy molds are used, no provision is made against shrinkage, and the casting is removed from the mold as soon as it has set, giving it no time to chill or to shrink by cooling. Over 6000 pieces have been cast in a single mold without its showing any signs of



**failure.** The mold should be so heavy that it will not become highly heated in use. Casting a 4-in. pipe weighing 65 lbs. every seven minutes in a mold weighing 6500 lbs. did not raise the temperature above 300° F. In using permanent molds the iron as it comes from the cupola should be very hot. The best results in casting pipe are had with iron containing over 3% carbon and about 2% silicon. Iron when cast in an iron mold and removed as soon as it sets, possesses some unusual properties. It will take a temper, and when tempered will retain magnetism. If the casting be taken from the mold at a bright heat and suddenly quenched in cold water, it has the cutting power of a good high-carbon steel, whether the iron be high or low in silicon, phosphorus, sulphur or manganese. There is no evidence of "chill"; no white crystals are shown.

Chilling molten iron swiftly to the point of setting, and then allowing it to cool gradually, produces a metal that is entirely new to the art. It has the chemical characteristics of cast iron, with the exception of combined carbon, and it also possesses some of the properties of high-carbon steel. A piece of cast iron that has 0.44% combined, and over 2% free carbon, has been tempered repeatedly and will do better service in a lathe than a good non-alloy steel. Once this peculiar property is imparted to the casting, it is impossible to eliminate it except by remelting. A bar of iron so treated can be held in a flame until the metal drips from the end, and yet quenching will restore it to its original hardness.

The character of the iron before being quenched is very fine, close-grained, and yet it is easily machined. If permanent molds can be used with success in the foundry, and a system of continuous pouring be inaugurated which in duplicate work would obviate the necessity of having molders, why is it necessary to melt pig iron in the cupola? What could be more ideal than a series of permanent molds supplied with molten iron practically direct from the blast furnace? The interposition of a reheating ladle such as is used by the steel makers makes possible the treatment of the molten iron.

The molten iron from the blast furnace is much hotter than that obtained from the cupola, so that there is every reason to believe that the castings obtained from a blast furnace would be of a better quality than when the pig is remelted in the cupola.

It is immaterial whether an iron contains 1.75 or 3% silicon, so long as the molten mass is at the proper temperature, so that the high temperatures obtained from the blast furnace would go far toward offsetting the variations in the impurities.

R. H. Probert (*Castings*, July, 1909) gives the following analysis of molds which gave the best results: Si, 2.02; S, 0.07; P, 0.89; Mn, 0.29; C.C., 0.84; G.C., 2.76. Molds made from iron with the following analysis were worthless: Si, 3.30; S, 0.06; P, 0.67; Mn, 0.12; C.C., 0.19; G.C., 2.98.

### Weight of Castings determined from Weight of Pattern.

(Rose's Pattern-makers' Assistant.)

A Pattern weighing One Pound, made of —	Will weigh when cast in				
	Cast Iron.	Zinc.	Copper.	Yellow Brass.	Gun metal.
	lbs.	lbs.	lbs.	lbs.	lbs.
Mahogany—Nassau.....	10.7	10.4	12.8	12.2	12.5
Honduras.....	12.9	12.7	15.3	14.6	15.
Spanish.....	8.5	8.2	10.1	9.7	9.9
Pine, red.....	12.5	12.1	14.9	14.2	14.6
" white.....	16.7	16.1	19.8	19.0	19.5
" yellow.....	14.1	13.6	16.7	16.0	16.5

**Molding Sand.** (Walter Bagshaw, *Proc. Inst. M. E.*, 1891.) — The chemical composition of sand will affect the nature of the casting, no matter what treatment it undergoes. Stated generally, good sand is composed of 94 parts silica, 5 parts alumina, and traces of magnesia and oxide of iron. Sand containing much of the metallic oxides, and especially

lime, is to be avoided. Geographical position is the chief factor governing the selection of sand; and whether weak or strong, its deficiencies are made up for by the skill of the molder. For this reason the same sand is often used for both heavy and light castings, the proportion of coal varying according to the nature of the casting. A common mixture of facing-sand consists of six parts by weight of old sand, four of new sand, and one of coal-dust. Floor-sand requires only half the above proportions of new sand and coal-dust to renew it. German founders adopt one part by measure of new sand to two of old sand; to which is added coal-dust in the proportion of one-tenth of the bulk for large castings, and one-twentieth for small castings. A few founders mix street-sweepings with the coal in order to get porosity when the metal in the mold is likely to be a long time in setting. Plumbago is effective in preventing destruction of the sand; but owing to its refractory nature, it must not be dusted on in such quantities as to close the pores and prevent free exit of the gases. Powdered French chalk, soapstone, and other substances are sometimes used for facing the mold; but next to plumbago, oak charcoal takes the best place, notwithstanding its liability to float occasionally and give a rough casting.

For the treatment of sand in the molding-shop the most primitive method is that of hand-riddling and treading. Here the materials are roughly proportioned by volume, and riddled over an iron plate in a flat heap, where the mixture is trodden into a cake by stamping with the feet; it is turned over with the shovel, and the process repeated. Tough sand can be obtained in this manner, its toughness being usually tested by squeezing a handful into a ball and then breaking it; but the process is slow and tedious. Other things being equal, the chief characteristics of a good molding-sand are toughness and porosity, qualities that depend on the manner of mixing as well as on uniform ramming.

**Toughness of Sand.** — In order to test the relative toughness, sand mixed in various ways was pressed under a uniform load into bars 1 in. sq. and about 12 in. long, and each bar was made to project further and further over the edge of a table until its end broke off by its own weight. Old sand from the shop floor had very irregular cohesion, breaking at all lengths of projections from 1/2 in. to 1 1/2 in. New sand in its natural state held together until an overhang of 2 3/4 in. was reached. A mixture of old sand, new sand, and coal-dust

Mixed under rollers..... broke at 2 to 2 1/4 in. of overhang.  
 " in the centrifugal machine... " " 2 " 2 1/4 " " "  
 " through a riddle..... " " 1 3/4 " 2 1/8 " " "

showing as a mean of the tests only slight differences between the last three methods, but in favor of machine-work. In many instances the fractures were so uneven that minute measurements were not taken.

Heinrich Ries (*Castings*, July, 1908) says that chemical analysis gives little or no information regarding the bonding power, texture, permeability or use of sand, the only case in which it is of value being in the selection of a highly silicious sand for certain work such as steel casting.

**Dimensions of Foundry Ladles.** — The following table gives the dimensions, inside the lining, of ladles from 25 lbs. to 16 tons capacity. All the ladles are supposed to have straight sides. (*Am. Mach.*, Aug. 4, 1892.)

Cap'y.	Diam.	Depth.	Cap'y.	Diam.	Depth.	Cap'y.	Diam.	Depth.
	in.	in.		in.	in.		in.	in.
16 tons	54	56	3 tons	31	32	300 lbs.	11 1/2	11 1/2
14 "	52	53	2 "	27	28	250 "	10 3/4	11
12 "	49	50	1 1/2 "	24 1/2	25	200 "	10	10 1/2
10 "	46	48	1 ton	22	22	150 "	9	9 1/2
8 "	43	44	3/4 "	20	20	100 "	8	8 1/2
6 "	39	40	1/2 "	17	17	75 "	7	7 1/2
4 "	34	35	1/4 "	13 1/2	13 1/2	50 "	6 1/2	6 1/2

## THE MACHINE-SHOP.

## SPEED OF CUTTING-TOOLS IN LATHES, MILLING MACHINES, ETC.

Relation of diameter of rotating tool or piece, number of revolutions and cutting-speed:

Let  $d$  = diam. of rotating piece in inches,  $n$  = No. of revs. per min.;

$S$  = speed of circumference in feet per minute;

$$S = \frac{\pi dn}{12} = 0.2618 dn; n = \frac{S}{0.2618 d} = \frac{3.82 S}{d}; d = \frac{3.82 S}{n}$$

Approximate rule: Number of revolutions per minute =  $4 \times$  speed in feet per minute  $\div$  diameter in inches.

Table of Cutting-speeds.

Diameter, Inches	Feet per minute.										
	10	20	30	40	50	75	100	150	200	250	300
	Revolutions per minute.										
1/4	152.8	305.6	458.4	611.2	764.0	1145.9	1527.9	2291.8	3055.8	3819.7	4583.7
3/8	101.9	203.7	305.6	407.4	509.3	763.7	1018.6	1527.5	2036.7	2545.8	3055.0
1/2	76.4	152.8	229.2	305.6	382.0	572.9	763.9	1145.9	1527.9	1909.9	2291.8
5/8	61.1	122.2	183.4	244.5	305.6	458.4	611.2	916.7	1222.3	1527.9	1833.5
3/4	50.9	101.8	152.8	203.7	254.6	382.0	509.3	763.9	1018.6	1273.2	1527.9
7/8	43.7	87.3	130.9	174.6	218.3	327.4	436.6	654.9	873.3	1091.5	1309.8
1	38.2	76.4	114.6	152.8	191.0	286.5	382.0	573.0	763.9	954.9	1145.9
1 1/8	34.0	67.9	101.8	135.8	169.7	254.4	339.5	508.8	678.4	848.0	1017.6
1 1/4	30.6	61.1	91.7	122.2	152.8	229.2	305.6	458.4	611.2	763.9	916.7
1 3/8	27.8	55.6	83.3	111.1	138.9	208.3	277.7	416.5	555.4	694.2	833.1
1 1/2	25.5	50.9	76.4	101.8	127.2	190.8	254.4	381.6	508.8	636.0	763.2
1 3/4	21.8	43.7	65.5	87.3	109.2	163.6	218.1	327.2	436.2	545.3	654.3
2	19.1	38.2	57.3	76.4	95.5	143.2	191.0	286.5	382.0	477.5	573.0
2 1/4	17.0	34.0	50.9	67.9	84.9	127.2	169.6	254.4	339.2	424.0	508.8
2 1/2	15.3	30.6	45.8	61.1	76.4	114.6	152.8	229.2	305.6	382.0	458.4
2 3/4	13.9	27.8	41.7	55.6	69.5	104.0	138.7	208.0	277.3	346.6	416.0
3	12.7	25.5	38.2	50.9	63.7	95.4	127.2	190.8	254.4	318.0	381.6
3 1/2	10.9	21.8	32.7	43.7	54.6	81.6	108.9	163.3	217.7	272.2	326.6
4	9.6	19.1	28.7	38.2	47.8	71.6	95.5	143.2	191.0	238.7	286.5
4 1/2	8.5	17.0	25.5	34.0	42.5	63.6	84.8	127.2	169.6	212.0	254.4
5	7.6	15.3	22.9	30.6	38.1	57.3	76.4	114.6	152.8	191.0	229.2
5 1/2	6.9	13.9	20.8	27.8	34.7	52.1	69.4	104.2	138.9	173.6	208.3
6	6.4	12.7	19.1	25.5	31.8	47.6	63.4	95.1	126.8	158.5	190.2
7	5.5	10.9	16.4	21.8	27.3	41.0	54.6	81.9	109.2	136.6	163.9
8	4.8	9.6	14.3	19.1	23.9	35.8	47.7	71.6	95.5	119.4	143.2
9	4.2	8.5	12.7	17.0	21.2	31.8	42.4	63.6	84.8	106.0	127.2
10	3.8	7.6	11.5	15.3	19.1	28.6	38.2	57.3	76.4	95.5	114.6
11	3.5	6.9	10.4	13.9	17.4	26.0	34.7	52.1	69.4	86.8	104.2
12	3.2	6.4	9.5	12.7	15.9	23.8	31.7	47.6	63.4	79.3	95.1
13	2.9	5.9	8.8	11.8	14.7	22.1	29.4	44.1	58.8	73.5	88.2
14	2.7	5.5	8.2	10.9	13.6	20.5	27.3	40.9	54.6	68.3	81.9
15	2.5	5.1	7.6	10.2	12.7	19.1	25.4	38.2	50.9	63.6	76.3
16	2.4	4.8	7.2	9.5	11.9	17.9	23.9	35.8	47.8	59.7	71.6
18	2.1	4.2	6.4	8.5	10.6	15.9	21.2	31.8	42.4	53.0	63.6
20	1.9	3.8	5.7	7.6	9.6	14.3	19.1	28.6	38.2	47.8	57.3
22	1.7	3.5	5.2	6.9	8.7	12.9	17.2	25.8	34.4	43.0	51.6
24	1.6	3.2	4.8	6.4	8.0	11.9	15.9	23.8	31.7	40.1	47.6
26	1.5	2.9	4.4	5.9	7.3	10.9	14.5	21.8	29.0	36.3	43.5
28	1.4	2.7	4.1	5.5	6.8	10.3	13.7	20.5	27.3	34.2	41.0
30	1.3	2.5	3.8	5.1	6.4	9.5	12.7	19.1	25.4	31.8	38.2
36	1.1	2.1	3.2	4.2	5.3	7.9	10.6	15.9	21.2	26.5	31.8
42	0.9	1.8	2.7	3.6	4.5	6.8	9.1	13.6	18.2	22.8	27.3
48	0.8	1.6	2.4	3.2	4.0	6.0	7.9	12.0	15.9	19.9	23.9
54	0.7	1.4	2.1	2.8	3.5	5.3	7.0	10.6	14.1	17.6	21.1
60	0.6	1.3	1.9	2.5	3.2	4.8	6.3	9.5	12.7	15.8	19.0



**The Speed of Counter-shaft** of the lathe is determined by an assumption of a slow speed with the back gear, say 6 feet per minute, on the largest diameter that the lathe will swing.

**EXAMPLE.** — A 30-inch lathe will swing 30 inches =, say, 90 inches circumference = 7 feet 6 inches; the lowest triple gear should give a speed of 5 or 6 feet per minute.

**Spindle Speeds of Lathes.** — The spindle speeds of lathes are usually in geometric progression, being obtained either by a combination of cone-pulley and back gears, or by a single pulley in connection with a gear train. Either of these systems may be used with a variable speed motor, giving a wide range of available speeds.

It is desirable to keep work rotating at a rate that will give the most economical cutting speed, necessitating, sometimes, frequent changes in spindle speed. A variable speed motor arranged for 20 speeds in geometric progression, any one of which can be used with any speed due to the mechanical combination of belts and back gears, gives a fine gradation of cutting speeds. The spindle speeds obtained with the higher speeds of the motor in connection with a certain mechanical arrangement of belt and back gears may overlap those obtained with the lower speeds available in the motor in connection with the next higher speed arrangement of belt and gears, but about 200 useful speeds are possible. E. R. Douglas (*Elec. Rev.*, Feb. 10, 1906) presents an arrangement of variable speed motor and geared head lathe, with 22 speed variations in the motor and 3 in the head. The speed range of the spindle is from 4.1 to 500 r.p.m. By the use of this arrangement, and taking advantage of the speed changes possible for different diameters of the work, a saving of 35.4 per cent was obtained in the time of turning a piece ordinarily requiring 289 minutes.

**Rule for Gearing Lathes for Screw-cutting.** (Garvin Machine Co.) — Read from the lathe index the number of threads per inch cut by equal gears, and multiply it by any number that will give for a product a gear on the index; put this gear upon the stud, then multiply the number of threads per inch to be cut by the same number, and put the resulting gear upon the screw.

**EXAMPLE.** — To cut  $11\frac{1}{2}$  threads per inch. We find on the index that 48 into 48 cuts 6 threads per inch, then  $6 \times 4 = 24$ , gear on stud, and  $11\frac{1}{2} \times 4 = 46$ , gear on screw. Any multiplier may be used so long as the products include gears that belong with the lathe. For instance, instead of 4 as a multiplier we may use 6. Thus,  $6 \times 6 = 36$ , gear upon stud, and  $11\frac{1}{2} \times 6 = 69$ , gear upon screw.

**Rules for Calculating Simple and Compound Gearing where there is no Index.** (*Am. Mach.*) — If the lathe is simple-gearred, and the stud runs at the same speed as the spindle, select some gear for the screw, and multiply its number of teeth by the number of threads per inch in the lead-screw, and divide this result by the number of threads per inch to be cut. This will give the number of teeth in the gear for the stud. If this result is a fractional number, or a number which is not among the gears on hand, then try some other gear for the screw. Or, select the gear for the stud first, then multiply its number of teeth by the number of threads per inch to be cut, and divide by the number of threads per inch on the lead-screw. This will give the number of teeth for the gear on the screw. If the lathe is compound, select at random all the driving-gears, multiply the numbers of their teeth together, and this product by the number of threads to be cut. Then select at random all the driven gears except one; multiply the numbers of their teeth together, and this product by the number of threads per inch in the lead-screw. Now divide the first result by the second, to obtain the number of teeth in the remaining driven gear. Or, select at random all the driven gears. Multiply the numbers of their teeth together, and this product by the number of threads per inch in the lead-screw. Then select at random all the driving-gears except one. Multiply the numbers of their teeth together, and this result by the number of threads per inch of the screw to be cut. Divide the first result by the last, to obtain the number of teeth in the remaining driver. When the gears on the compounding stud are fast together, and cannot be changed, then the driven one has usually twice as many teeth as the other, or driver, in which case in the calculations consider the lead-screw to have twice as many threads per inch as it actually has, and then ignore

the compounding entirely. Some lathes are so constructed that the stud on which the first driver is placed revolves only half as fast as the spindle. This can be ignored in the calculations by doubling the number of threads of the lead-screw. If both the last conditions are present ignore them in the calculations by multiplying the number of threads per inch in the lead-screw by four. If the thread to be cut is a fractional one, or if the pitch of the lead-screw is fractional, or if both are fractional, then reduce the fractions to a common denominator, and use the numerators of these fractions as if they equaled the pitch of the screw to be cut, and of the lead-screw, respectively. Then use that part of the rule given above which applies to the lathe in question. For instance, suppose it is desired to cut a thread of  $\frac{25}{32}$ -inch pitch, and the lead-screw has 4 threads per inch. Then the pitch of the lead-screw will be  $\frac{1}{4}$  inch, which is equal to  $\frac{8}{32}$  inch. We now have two fractions,  $\frac{25}{32}$  and  $\frac{8}{32}$ , and the two screws will be in the proportion of 25 to 8, and the gears can be figured by the above rule, assuming the number of threads to be cut to be 8 per inch, and those on the lead-screw to be 25 per inch. But this latter number may be further modified by conditions named above, such as a reduced speed of the stud, or fixed compound gears. In the instance given, if the lead-screw had been  $2\frac{1}{2}$  threads per inch, then its pitch being  $\frac{4}{10}$  inch, we have the fractions  $\frac{4}{10}$  and  $\frac{25}{32}$ , which, reduced to a common denominator, are  $\frac{64}{160}$  and  $\frac{125}{160}$ , and the gears will be the same as if the lead-screw had 125 threads per inch, and the screw to be cut 64 threads per inch.

On this subject consult also "Formulas in Gearing," published by Brown & Sharpe Mfg. Co., and Jamieson's Applied Mechanics.

**Change-gears for Screw-cutting Lathes.**—There is a lack of uniformity among lathe-builders as to the change-gears provided for screw-cutting. W. R. Macdonald, in *Am. Mach.*, April 7, 1892, proposed the following series, by which 33 whole threads (not fractional) may be cut by changes of only nine gears:

Screw.	Spindle.									Whole Threads.			
	20	30	40	50	60	70	110	120	130				
20	..	8	6	$4\frac{4}{5}$	4	$3\frac{3}{7}$	$2\frac{2}{11}$	2	$1\frac{11}{13}$	2	11	22	44
30	18	..	9	$7\frac{1}{5}$	6	$5\frac{1}{7}$	$3\frac{3}{11}$	3	$2\frac{10}{13}$	3	12	24	48
40	24	16	12	$9\frac{3}{5}$	8	$6\frac{6}{7}$	$4\frac{4}{11}$	4	$3\frac{9}{13}$	4	13	26	52
50	30	20	15	..	10	$8\frac{4}{7}$	$5\frac{5}{11}$	5	$4\frac{8}{13}$	5	14	28	66
60	36	24	18	$14\frac{2}{5}$	..	$10\frac{2}{7}$	$6\frac{6}{11}$	6	$5\frac{7}{13}$	6	15	30	72
70	42	28	21	$16\frac{4}{5}$	14	..	$7\frac{7}{11}$	7	$6\frac{8}{13}$	7	16	33	78
110	66	44	33	$26\frac{2}{5}$	22	$18\frac{6}{7}$	..	11	$10\frac{2}{13}$	8	18	36	
120	72	48	36	$28\frac{4}{5}$	24	$20\frac{4}{7}$	$13\frac{1}{11}$	..	$11\frac{1}{13}$	9	20	39	
130	78	52	39	$31\frac{1}{5}$	26	$22\frac{3}{7}$	$14\frac{2}{11}$	13	..	10	21	42	

Ten gears are sufficient to cut all the usual threads, with the exception of perhaps  $11\frac{1}{2}$ , the standard pipe-thread; in ordinary practice any fractional thread between 11 and 12 will be near enough for the customary short pipe-thread; if not, the addition of a single gear will give it.

In this table the pitch of the lead-screw is 12, and it may be objected to as too fine for the purpose. This may be rectified by making the real pitch 6 or any other desirable pitch, and establishing the proper ratio between the lathe spindle and the gear-stud.

**"Quick Change Gears."**—About 1905, lathe manufacturers began building "quick change" lathes in which gear changing for screw cutting is eliminated. The lead-screw carries a cone of gears, one of which is in mesh with a movable gear in a nest of gears driven from the spindle. By changing the position of this movable gear, in relation to the cone of gears, the proper ratio of speeds between the spindle and lead-screws is obtained for cutting any desired thread usual in the range of the machine. About 16 different numbers of threads per inch can usually be cut by means of the "quick change" gear train. Different threads from those usually available can be cut by means of change gears between the spindle

and "quick change" gear train. The threads per inch usually available range from 2 to 46 in a 12-in. lathe to 1 to 24 in a 30-in. lathe. Catalogs of lathe manufacturers should be consulted for constructional details.

**Shapes of Tools.** For illustrations and descriptions of various forms of cutting-tools, see Taylor's Experiments, below; also see Standard Planer Tools, p. 1271, and articles on Lathe Tools in Appleton's Cyc. Mech., vol. ii, and in Modern Mechanism.

**Cold Chisels.**—Angle of cutting-faces (Joshua Rose): For cast steel, about 65 degrees; for gun-metal or brass, about 50 degrees; for copper and soft metals, about 30 to 35 degrees.

**Metric Screw-threads** may be cut on lathes with inch-divided leading-screws, by the use of change-wheels with 50 and 127 teeth; since 127 centimeters = 50 inches ( $127 \times 0.3937 = 49.9999$  in.).

**Rule for Setting the Taper in a Lathe.** (*Am. Mach.*)—No rule can be given which will produce exact results, owing to the fact that the centers enter the work an indefinite distance. If it were not for this circumstance the following would be an exact rule, and it is an approximation as it is. To find the distance to set the center over: Divide the difference in the diameters of the large and small ends of the taper by 2, and multiply this quotient by the ratio which the total length of the shaft bears to the length of the tapered portion. **EXAMPLE:** Suppose a shaft three feet long is to have a taper turned on the end one foot long, the large end of the taper being two inches and the small end one inch diameter,

$$\frac{2 - 1}{2} \times \frac{3}{1} = 1\frac{1}{2} \text{ inches.}$$

☐ **Lubricants for Lathe Centers.**—*Machinery* recommends as lubricants for lathe centers to prevent cutting or abrasion: 1. Dry or powdered red lead mixed with a good mineral oil to the consistency of cream. 2. White lead mixed with sperm oil, together with enough graphite to give the mixture a dark red color. 3. One part graphite, four parts tallow, thoroughly mixed.

### TAYLOR'S EXPERIMENTS.

Fred W. Taylor directed a series of experiments, extending over 26 years, on feeds, speeds, shape of tool, composition of tool steel, and heat treatment. His results are given in *Trans. A. S. M. E.*, xxviii, "The Art of Cutting Metals." The notes below apply mainly to tools of high speed steel and to heavy work requiring tools not less than  $\frac{1}{2}$  by  $\frac{3}{4}$  inch in cross-section.

**Proper Shape of Lathe Tool.**—Mr. Taylor discovered the best shape for lathe tools to be as shown in Fig. 194 with the angles given in the following table, when used on materials of the class shown. The exact outline of the nose of the tool is shown in Fig. 195. The actual dimensions of a 1-inch roughing tool are shown in Fig. 196. Let  $R$  = radius of point of tool,  $A$  = width of tool,  $L$  = length of shank, and  $H$  = height of shank, all in inches. Then  $L = 14A + 4$ ;  $H = 1.5A$ ;  $R = 0.5A - 0.3125$  for cutting hard steel and cast iron;  $R = 0.5A - 0.1875$  for soft steel. The meaning of the terms back slope, etc., is shown in Fig. 194.

#### Angles for Tools.

* Material cut.	$a$ = clearance.	$b$ = back slope.	$c$ = side slope.
Cast iron; Hard steel.	6 degrees.	8 degrees.	14 degrees.
Medium or Soft steel.	6 degrees.	8 degrees.	22 degrees.
Tire steel.	6 degrees.	5 degrees.	9 degrees.

\* As far as the shape of the tool is concerned, Taylor divided metals to be cut into general classes: (a) cast iron and hard steel, steel of 0.45–0.50 per cent carbon, 100,000 pounds tensile strength, and 18 per cent stretch, being a low limit of hardness; (b) soft steel, softer than above; (c) chilled iron; (d) tire steel; (e) extremely soft steel of carbon, say, 0.10–0.15 per cent.

The table presupposes the use of an automatic tool grinder. If tools are ground by hand the clearance angle should be 9 degrees. The lip angles for tools cutting hard steel and cast iron should be 68 degrees;



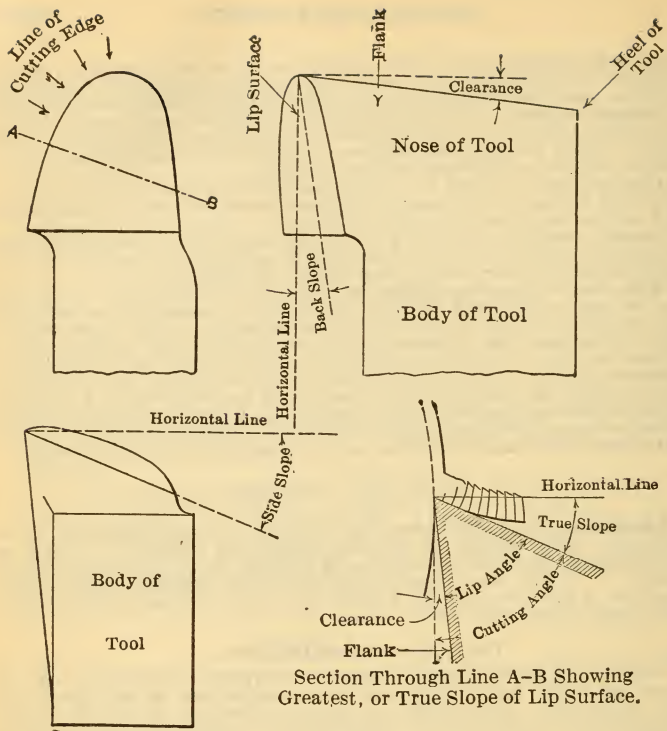

FIG. 194.

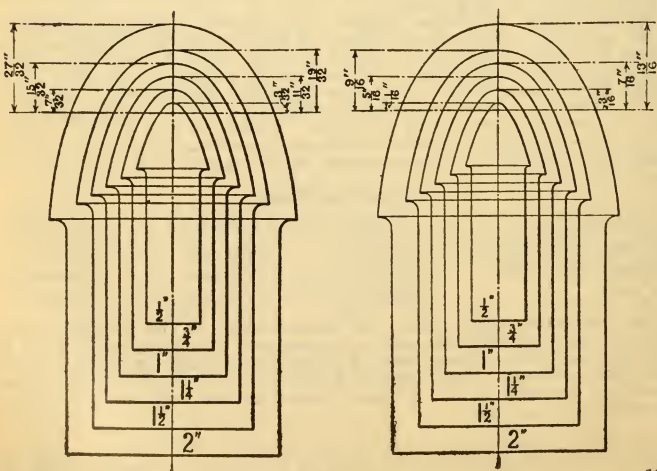

FIG. 195.

for soft steel, 61 degrees; for chilled iron, 86 to 90 degrees; for tire steel, 74 degrees; for extremely soft steel, keener than 61 degrees. A tool should be given more side than back slope; it can then be ground more times without weakening, the chip does not strike the tool post or clamps,

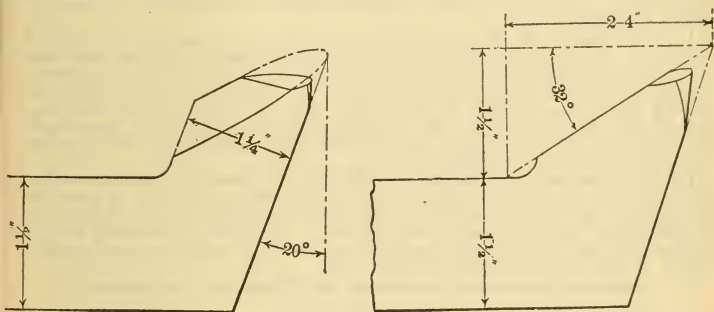
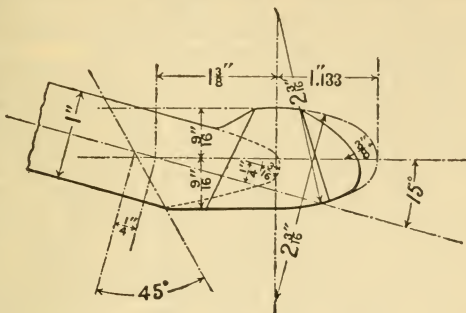

FIG. 196.

and it is also easier to feed. The nose of the tool should be set to one side, as in Fig. 196 above, to avoid any tendency to upset. To use a tool of this shape, lathe tool posts should be set lower below the center of the work than is now (1907) customary.

**Forging and Grinding Tools.**—The best method of dressing a tool is to turn one end up nearly at right angles to the shank, so that the nose will be high above the top of the body of the tool. Dressing can be thus done in two heats. Tools should leave the smith shop with a clearance angle of 20 degrees. Detailed directions for dressing a tool are given in Mr. Taylor's paper. To avoid overheating the tool in grinding, a stream of water, of at least five gallons a minute, should be thrown at low velocity on the nose of the tool where it is in contact with the emery wheel. In hand grinding, tools should not be held firmly against the wheel, but should be moved over its surface. It is of the utmost importance that high speed steel tools should not be heated above 1200° F. in grinding. Automatic tool grinders are economical, even in a small shop. Grinding machines should have some means for automatically adjusting the pressure of the tool against the grinding wheel. Each size of tool should have adapted to it a pressure, automatically adjusted, and which is just sufficient to grind rapidly without overheating the tool. Standard shapes should be adopted, to which all tools should be ground. There being no economy in automatic grinding without standard shapes,

**Best Grinding Wheel.**—The best grinding wheel was found to be a corundum wheel, of a mixture of 24 and 30 grit.

**Pressure of Tool, etc.**—Mr. Taylor found that there is no definite relation between the cutting speed of tools and the pressure with which the chip bears on the lip surface of the tool. He found, however, that the pressure per square inch of sectional area of the chip increases slightly as the thickness of the chip decreases. The feeding pressure of the tool is sometimes equal to the entire driving pressure of the chip against the lip surface of the tool, and the feed gears should be designed to deliver a pressure of this magnitude at the nose of the tool.

**Chatter.**—Chatter is caused by: too small lathe dogs; imperfect bearing at the points where the face plate drives the dogs; badly made or badly fitted gears; shafts in the machine of too small diameter, or of too great length; loose fits in bearings. A tool which chatters must be run at a cutting speed about 15 per cent slower than can be used if the tool does not chatter, irrespective of the use or non-use of water on the tool. A higher cutting speed can be used with an intermittent cut, as occurs on a planer, or shaper, or in turning, say, the periphery of a gear, than with a steady cut. To avoid chatter, tools should have curved cutting edges, or two or more tools should be used at the same time in the same machine. The body of the tool should be greater in height than width, and should have a true, solid bearing on the tool support, which latter should extend to almost beneath the cutting edge of the tool. Machines should be made massive beyond the metal needed for strength alone, and steady rests should be used on long work. It is advisable to use a steady rest, when turning any cylindrical piece of diameter  $D$ , when the length exceeds  $12 D$ .

**Use of Water on Tool.**—With the best high speed steel tools, a gain of 14 per cent in cutting speed can be made in cutting cast-iron and hard steel to 35 per cent on very hard steel by throwing a heavy stream of water directly on the chip at the point where it is being removed from the forging by the tool. Not less than three gallons a minute should be used for a  $2 \times 2\frac{1}{2}$ -in. tool. The gain is practically the same for all qualities of steel, regardless of hardness and whether thick or thin chips are being cut.

**Interval between Grindings.**—Mr. Taylor derived a table showing how long various sizes of tools should run without regrinding to give the maximum work for the lowest all-around cost. Time a tool should run continuously without regrinding equals  $7 \times$  (time to change tool + proper portion of time for redressing + time for grinding + time equivalent to cost of the tool steel ground off).

**INTERVAL BETWEEN GRINDINGS, AT MAXIMUM ECONOMICAL CUTTING SPEEDS.**

Size of tool.					
Inches.	$\frac{1}{2} \times \frac{3}{4}$	$\frac{5}{8} \times 1$	$\frac{3}{4} \times 1\frac{1}{8}$	$\frac{7}{8} \times 1\frac{3}{8}$	$1 \times 1\frac{1}{2}$
Hours.	1.25	1.25	1.25	1.5	1.5
Size of tool.					
Inches.	$1\frac{1}{4} \times 1\frac{7}{8}$	$1\frac{1}{2} \times 2\frac{1}{4}$	$1\frac{3}{4} \times 2\frac{3}{4}$	$2 \times 3$	
Hours.	1.75	2.0	2.5	2.75	

If the proper cutting speed ( $A$ ) is known for a cut of given duration, the speed for a cut ( $B$ ) of different duration can be obtained by multiplying ( $A$ ) by the factor given in the following table:

**Duration of cut in minutes:**

At known speed ( $A$ ) .....	20	40	20	40	80	80
At derived speed ( $B$ ) .....	40	80	80	20	40	20
Factor .....	0.92	0.92	0.84	1.09	1.09	1.19

For cutting speeds of high-speed lathe tools to last  $1\frac{1}{2}$  hours, see tables on pages 1266 and 1267.

**Effect of Feed and Depth of Cut on Cutting Speed.**—With a given depth of cut, metal can be removed faster with a coarse feed and slow speed, than with fine feed and high speed. With a given depth of cut, a cutting speed of  $S$ , and a feed of  $F$ ,  $S$  varies approximately as  $1/\sqrt{F}$ . With tools of the best high speed steel, varying the feed and depth of cut varies the cutting speed in the same ratio when cutting hard steel as when cutting soft steel.



**Best High Speed Tool Steel — Composition — Heat Treatment.**

— Mr. Taylor and Maunsel White developed a number of high speed steels, the one showing the best all-around qualities having the following chemical composition: Vanadium, 0.29; tungsten, 18.19; chromium, 5.47; carbon, 0.674; manganese, 0.11; silicon, 0.043. The use of vanadium materially improves high speed steel. The following method of treatment is described as the best for this or any other composition of high speed steel. The tool should be forged at a light yellow heat, and, after forging slowly and uniformly heated to a bright cherry red, allowing plenty of time for the heat to penetrate to the center of the tool, in order to avoid danger of cracking due to too rapid heating. The tool should then be heated from a bright cherry red to practically its melting-point as rapidly as possible in an intensely hot fire; if the extreme nose of the tool is slightly fused no harm is done. Time should be allowed for the tool to become uniformly hot from the heel to the lip surface.

After the high heat has been given the tools, as above described, they should be cooled rapidly until they are below the "breaking-down point," or, say, down to or below 1550° F. The quality of the tool will be but little affected whether it is cooled rapidly or slowly from this point down to the temperature of the air. Therefore, after all parts of a tool from the outside to the center have reached a uniform temperature below the breaking-down point, it is the practice sometimes to lay it down in any part of the room or shop which is free from moisture, and let it cool in the air, and sometimes to cool it in an air blast to the temperature of the air.

The best method of cooling from the high heat to below the breaking-down point is to plunge the tools into a bath of red-hot molten lead below the temperature of 1550° F. They should then be plunged into a lead bath maintained at a uniform temperature of 1150° F., because the same bath is afterward used for reheating the tools to give them their second treatment. This bath should contain a sufficiently large body of the lead so that its temperature can be maintained uniform; and for this purpose should be used preferably a lead bath containing about 3600 lb. of lead.

Too much stress cannot be laid upon the importance of never allowing the tool to have its temperature even slightly raised for a very short time during the process of cooling down. The temperature must either remain absolutely stationary or continue to fall after the operation of cooling has once started, or the tool will be injured. Any temporary rise of temperature during cooling, however small, will injure the tool. This, however, applies only to cooling the tool to the temperature of about 1240° F. Between the limits of 1240 degrees and the temperature of the air, the tool can be raised or lowered in temperature time after time and for any length of time without injury. And it should also be noted that during the first operation of heating the tool from its cold state to the melting-point, no injury results from allowing it to cool slightly and then reheating. It is from reheating during the operation of cooling from the high heat to 1240° F. that the tool is injured.

The above-described operation is commonly known as the first or high-heat treatment.

To briefly recapitulate, the first or high-heat treatment consists of heating the tool —

- (a) slowly to 1500° F.;
- (b) rapidly from that temperature to just below the melting-point.
- (c) cooling fast to below the breaking-down point, i.e., 1550° F.
- (d) cooling either fast or slowly from 1550° F. to temperature of the air.

**Second Treatment, Reheating the Cooled Tool.** — After air-temperature has been reached the tool should be reheated to a temperature of from 700 to 1240° F., preferably by plunging it in the before-mentioned lead bath at 1150° F. and kept at that temperature at least five minutes. To avoid danger of fire cracks, the tool should be heated slowly before immersing in the bath. The above tool heated in this fashion possesses a high degree of "red hardness" (ability to cut steel with the nose of the tool at red heat), while it is not extraordinarily hard at ordinary temperatures. It is difficult to injure it by overheating on the grindstone or in the lathe. It will operate at 90 per cent of its maximum cutting speed, even without the second or low-heat treatment. A coke fire is preferable for giving the first heat, and it should be made as deep as possible.

Cutting Speeds in Feet per Minute of Standard Taylor-White Tools, Tool to Last 1/2 Hours between Grindings.

Tool. Material Cut.	1 1/4-Inch.						1-Inch.						7/8-Inch.					
	Steel.			Cast Iron.			Steel.			Cast Iron.			Steel.			Cast Iron.		
	Soft.	Me- dium.	Hard.	Soft.	Me- dium.	Hard.	Soft.	Me- dium.	Hard.	Soft.	Me- dium.	Hard.	Soft.	Me- dium.	Hard.	Soft.	Me- dium.	Hard.
8/32	1/64	518.0	118.0	239.0	119.6	69.8	490.0	245.0	111.0	226.0	113.0	66.0	476.0	238.0	108.0	220.0	110.0	64.2
	1/32	366.0	83.2	191.0	95.3	55.6	339.0	169.0	77.0	177.0	88.4	51.6	325.0	162.0	73.8	169.0	84.6	49.4
	3/32	257.0	58.4	142.0	70.8	41.3	235.0	117.0	53.4	130.0	64.8	37.8	222.0	111.0	50.4	122.0	61.2	35.7
	1/8	209.0	47.5	118.0	59.1	34.4	189.0	94.5	43.0	107.0	53.5	31.2	177.0	88.4	40.2	99.8	49.9	29.1
1/8	1/64	450.0	102.0	216.0	108.0	63.1	427.0	214.0	97.0	205.0	102.0	59.8	420.0	210.0	95.5	202.4	101.0	58.9
	1/32	317.0	72.0	172.0	86.2	50.3	296.0	148.0	67.2	160.0	85.1	46.8	286.0	143.0	65.0	156.0	77.8	45.4
	3/32	182.0	50.7	128.0	64.0	37.3	205.0	102.0	46.6	118.0	58.8	34.3	195.0	97.6	44.4	112.0	56.2	32.8
	1/4	157.0	35.7	93.4	46.7	27.3	142.0	71.0	32.3	97.0	48.5	23.3	156.0	77.9	35.4	91.8	45.9	26.8
3/16	1/64	370.0	84.1	187.0	93.5	54.6	358.0	179.0	81.3	181.0	90.6	52.9	332.0	176.0	80.0	178.0	89.0	52.0
	1/32	260.0	59.1	149.0	74.6	43.6	247.0	124.0	56.1	142.0	70.8	41.3	240.0	120.0	54.5	137.0	68.6	40.1
	3/32	183.0	41.6	111.0	55.5	32.7	171.0	85.5	38.8	104.0	51.9	30.3	164.0	82.0	37.3	99.4	49.7	29.0
	1/2	149.0	33.8	92.5	46.3	27.0	138.0	69.0	31.3	85.8	42.9	25.0	131.0	65.5	29.8	81.0	40.5	23.7
1/4	1/64	322.0	73.2	168.0	84.1	49.1	315.0	157.0	71.6	165.0	82.3	48.1	312.0	156.0	70.9	163.0	81.5	47.7
	1/32	227.0	51.6	134.0	67.2	39.2	218.0	109.0	49.5	129.0	64.4	37.5	213.0	107.0	48.4	126.0	62.9	36.7
	3/32	130.0	36.1	99.8	49.9	29.1	150.0	75.0	34.1	94.3	47.1	27.5	145.0	72.6	33.0	90.8	45.4	26.5
	3/8	91.4	25.5	72.6	36.3	21.2	104.0	52.0	23.6	67.5	33.7	19.7	116.0	58.1	26.4	74.1	37.0	21.6
3/8	1/64	264.0	60.0	144.0	71.8	41.9	263.0	132.0	59.8	143.0	71.5	41.8	264.0	132.0	60.0	144.0	71.8	41.9
	1/32	186.0	42.3	115.0	57.3	35.4	182.0	91.0	41.4	112.0	56.0	32.6	180.0	90.2	41.0	111.0	55.4	32.3
	3/32	107.0	24.1	70.9	35.5	20.7	101.0	50.6	23.0	67.6	33.8	19.7	122.0	61.1	27.8	80.0	40.0	23.4
	1/2	92.2	20.8	62.0	31.0	18.1	82.0	41.0	18.9	58.6	29.3	17.1	92.2	46.1	20.8	62.0	31.0	18.9
1/2	1/64	230.0	52.3	131.0	65.6	38.3	232.0	116.0	52.7	132.0	66.2	38.6	237.0	118.0	53.8	135.0	67.5	39.4
	1/32	162.0	36.8	105.0	52.3	30.5	161.0	80.5	36.6	104.0	51.6	30.2	162.0	80.8	36.7	104.0	52.1	30.4
	3/32	114.0	25.9	77.6	38.8	22.7	111.0	55.7	25.3	75.8	37.9	22.1	111.0	55.7	25.3	75.8	37.9	22.1
	1/2	92.6	21.0	64.7	32.4	18.9	64.7	32.4	18.9	62.6	31.3	18.3	92.6	46.3	21.0	64.7	32.4	18.9
3/16	1/64	370.0	84.1	187.0	93.5	54.6	358.0	179.0	81.3	181.0	90.6	52.9	332.0	176.0	80.0	178.0	89.0	52.0
	1/32	260.0	59.1	149.0	74.6	43.6	247.0	124.0	56.1	142.0	70.8	41.3	240.0	120.0	54.5	137.0	68.6	40.1
	3/32	183.0	41.6	111.0	55.5	32.7	171.0	85.5	38.8	104.0	51.9	30.3	164.0	82.0	37.3	99.4	49.7	29.0
	1/2	149.0	33.8	92.5	46.3	27.0	138.0	69.0	31.3	85.8	42.9	25.0	131.0	65.5	29.8	81.0	40.5	23.7
3/16	1/64	322.0	73.2	168.0	84.1	49.1	315.0	157.0	71.6	165.0	82.3	48.1	312.0	156.0	70.9	163.0	81.5	47.7
	1/32	227.0	51.6	134.0	67.2	39.2	218.0	109.0	49.5	129.0	64.4	37.5	213.0	107.0	48.4	126.0	62.9	36.7
	3/32	130.0	36.1	99.8	49.9	29.1	150.0	75.0	34.1	94.3	47.1	27.5	145.0	72.6	33.0	90.8	45.4	26.5
	1/2	91.4	25.5	72.6	36.3	21.2	104.0	52.0	23.6	67.5	33.7	19.7	116.0	58.1	26.4	74.1	37.0	21.6
3/16	1/64	264.0	60.0	144.0	71.8	41.9	263.0	132.0	59.8	143.0	71.5	41.8	264.0	132.0	60.0	144.0	71.8	41.9
	1/32	186.0	42.3	115.0	57.3	35.4	182.0	91.0	41.4	112.0	56.0	32.6	180.0	90.2	41.0	111.0	55.4	32.3
	3/32	107.0	24.1	70.9	35.5	20.7	101.0	50.6	23.0	67.6	33.8	19.7	122.0	61.1	27.8	80.0	40.0	23.4
	1/2	92.2	20.8	62.0	31.0	18.1	82.0	41.0	18.9	58.6	29.3	17.1	92.2	46.1	20.8	62.0	31.0	18.9
3/16	1/64	230.0	52.3	131.0	65.6	38.3	232.0	116.0	52.7	132.0	66.2	38.6	237.0	118.0	53.8	135.0	67.5	39.4
	1/32	162.0	36.8	105.0	52.3	30.5	161.0	80.5	36.6	104.0	51.6	30.2	162.0	80.8	36.7	104.0	52.1	30.4
	3/32	114.0	25.9	77.6	38.8	22.7	111.0	55.7	25.3	75.8	37.9	22.1	111.0	55.7	25.3	75.8	37.9	22.1
	1/2	92.6	21.0	64.7	32.4	18.9	64.7	32.4	18.9	62.6	31.3	18.3	92.6	46.3	21.0	64.7	32.4	18.9
3/16	1/64	370.0	84.1	187.0	93.5	54.6	358.0	179.0	81.3	181.0	90.6	52.9	332.0	176.0	80.0	178.0	89.0	52.0
	1/32	260.0	59.1	149.0	74.6	43.6	247.0	124.0	56.1	142.0	70.8	41.3	240.0	120.0	54.5	137.0	68.6	40.1
	3/32	183.0	41.6	111.0	55.5	32.7	171.0	85.5	38.8	104.0	51.9	30.3	164.0	82.0	37.3	99.4	49.7	29.0
	1/2	149.0	33.8	92.5	46.3	27.0	138.0	69.0	31.3	85.8	42.9	25.0	131.0	65.5	29.8	81.0	40.5	23.7
3/16	1/64	322.0	73.2	168.0	84.1	49.1	315.0	157.0	71.6	165.0	82.3	48.1	312.0	156.0	70.9	163.0	81.5	47.7
	1/32	227.0	51.6	134.0	67.2	39.2	218.0	109.0	49.5	129.0	64.4	37.5	213.0	107.0	48.4	126.0	62.9	36.7
	3/32	130.0	36.1	99.8	49.9	29.1	150.0	75.0	34.1	94.3	47.1	27.5	145.0	72.6	33.0	90.8	45.4	26.5
	1/2	91.4	25.5	72.6	36.3	21.2	104.0	52.0	23.6	67.5	33.7	19.7	116.0	58.1	26.4	74.1	37.0	21.6
3/16	1/64	264.0	60.0	144.0	71.8	41.9	263.0	132.0	59.8	143.0	71.5	41.8	264.0	132.0	60.0	144.0	71.8	41.9
	1/32	186.0	42.3	115.0	57.3	35.4	182.0	91.0	41.4	112.0	56.0	32.6	180.0	90.2	41.0	111.0	55.4	32.3
	3/32	107.0	24.1	70.9	35.5	20.7	101.0	50.6	23.0	67.6	33.8	19.7	122.0	61.1	27.8	80.0	40.0	23.4
	1/2	92.2	20.8	62.0	31.0	18.1	82.0	41.0	18.9	58.6	29.3	17.1	92.2	46.1	20.8	62.0	31.0	18.9
3/16	1/64	230.0	52.3	131.0	65.6	38.3	232.0	116.0	52.7	132.0	66.2	38.6	237.0	118.0	53.8	135.0	67.5	39.4
	1/32	162.0	36.8	105.0	52.3	30.5	161.0	80.5	36.6	104.0	51.6	30.2	162.0	80.8	36.7	104.0	52.1	30.4
	3/32	114.0	25.9	77.6	38.8	22.7	111.0	55.7	25.3	75.8	37.9	22.1	111.0	55.7	25.3	75.8	37.9	22.1
	1/2	92.6	21.0	64.7	32.4	18.9	64.7	32.4	18.9	62.6	31.3	18.3	92.6	46.3	21.0	64.7	32.4	18.9
3/16	1/64	370.0	84.1	187.0	93.5	54.6	358.0	179.0	81.3	181.0	90.6	52.9	332.0	176.0	80.0	178.0	89.0	52.0
	1/32	260.0	59.1	149.0	74.6	43.6	247.0	124.0	56.1	142.0	70.8	41.3	240.0	120.0	54.5	137.0	68.6	40.1
	3/32	183.0	41.6	111.0	55.5	32.7	171.0	85.5	38.8	104.0	51.9	30.3	164.0	82.0	37.3	99.4	49.7	29.0
	1/2	149.0	33.8	92.5	46.3	27.0	138.0	69.0	31.3	85.8	42.9	25.0	131.0	65.5	29.8	81.0	40.5	23.7
3/16	1/64	322.0	73.2	168.0	84.1	49.1	315.0	157.0	71.6	165.0	82.3	48.1	312.0	156.0	70.9			





Cooling the tool by plunging it in oil or water, renders it liable to fire cracks and to brittleness in the body. Next to the lead bath an air blast is preferable for cooling.

**Best Method of Treating Tools in Small Shops.**—For small shops, in treating high-speed tools, Mr. Taylor considers the best method to be as follows for the blacksmith who is equipped only with the apparatus ordinarily found in a smith-shop.

After the tools have been forged and before starting to give them their heat, fuel should be added to the smith's fire so as to give a good deep bed either of coke about the size of a walnut or of first-class blacksmiths' soft coal. A number of tools should then be laid with their noses at a slight distance from the hotter portion of the fire, so that they may all be pre-heating while the fire is being blown up to its proper intensity. After reaching its proper intensity, the tools should be heated one at a time over the hottest part of the fire as rapidly as practicable up to just below their melting-point. During this operation they should be repeatedly turned over and over so as to insure a uniform high heat throughout the whole end of the tool. As soon as each tool reaches its high heat, it should be placed with its nose under a heavy air blast and allowed to cool to the temperature of the air before being removed from the blast.

Unfortunately, however, the blacksmith's fire is so shallow that it is incapable of maintaining its most intense heat for more than a comparatively few minutes, and, therefore, it is only through these few minutes that first-class high-speed tools can be properly heated in the smith's fire. Great numbers of high-speed tools are daily turned out from smiths' fires which are not sufficiently intense in their heat, and they are therefore inferior in red hardness and produce irregular cutting tools.

On the whole, a blacksmith's fire made from coke may be regarded as better for giving the high heat to tools than a soft-coal fire, merely because a coke fire can be more easily made by the smith which will remain capable for a longer period of heating the tools quickly to their melting-points.

**Quality of Different Tool Steels.**—Mr. Taylor in a letter to the author, Dec. 30, 1907, says:

*First.* Any of a half dozen makes of high speed tools now on the market are amply good, and but little attention need be paid to the special directions for heating and cooling high speed tools given by the makers of the tool steel. The most important matter is that an intensely hot fire should be used for giving the tools their high heat, and that they should not be allowed to soak a long time in this fire. They should be heated as fast as possible and then cooled in an air blast.

*Second.* The greatest number of tools are ruined on the emery wheel through overheating, either because a wheel whose surface is glazed is used, or because too small a stream of water is run upon the nose of the tool. The emery wheel should be kept sharp through frequent dressings with a diamond tool.

*Third.* Uniformity is the most important quality in high speed tools. For this reason, only one make of high speed tool steel should be used in each shop.

**Economical Cutting Speeds.**—Tools shaped as in Fig. 196, and of the chemical composition and heat treatment given in the preceding paragraphs, should be run at the cutting speeds given in the tables on pages 1266 and 1267 in order to last one hour and 30 minutes without re-grinding.

**Cutting Speed of Parting and Thread Tools.**—To find the economical cutting speed of a parting tool of the best high-speed steel, first ascertain the thickness of chip which is to be cut by the tool. Then from the tables on pages 1266 and 1267, under the standard  $7/8$ -in. tool and  $3/16$  in. depth of cut, and opposite the feed which most nearly corresponds to the thickness of chip to be taken by the parting tool, find the speed. Divide the figure so found by 2.7 to ascertain the speed for the parting tool. For thread tools, the process is the same, except that the divisor is 4. The thickness of chip in the latter case is the advance in inches per revolution of the tool toward the center of the work.

**Durability of Cutting Tools.**—E. G. Herbert (*Am. Mach.*, June 24, 1909) shows that the durability of a tool depends mainly on the temperature to which its extreme edge is raised, and that the rate of evolution of heat and consequently the durability is proportional to the thick-

ness and to the area of the chip and to the cube of the cutting speed. Or if  $t_1$  = thickness or feed,  $c_1$  = depth of cut,  $a_1$  = area of the cut and  $s_1$  = cutting speed, for any given set of working conditions, and  $t_2c_2a_2$  and  $s_2$  values for another set of conditions, then the durability of the tool will be the same when  $t_1a_1s_1^3 = t_2a_2s_2^3$ , or for constant durability  $s_2 = s_1 \sqrt[3]{(t_1^2 c_1) \div (t_2^2 c_2)}$ .

**Other High-Speed Steels.**—*Am. Mach.* April 8, May 20 and 27, 1909, describes the operations of some new varieties of high-speed steel made by Sheffield manufacturers, which show results superior to those of the earlier high-speed steels in endurance of tool, ability to cut very hard metals, and higher speeds. The following are the results of some of the tests in lathe-work:

Tool size. in.	Material Cut.	Diam. in.	Depth. cut in.	Feed in.	Speed ft. per min.	Length of Cut.
1 1/4	Steel, 2.00 C.....	.....	3/8	1/16	36	43/4 in.*
1 1/4	Steel, 0.70 C.....	.....	1/4	1/16	48	13 in.†
1 1/4	Steel, 0.70 C.....	.....	3/16	1/16	65	87/8 in.
7/8	Steel, 0.40 C.....	4	1/8	1/16	65	28 ins., †
7/8	Steel, 0.40 C.....	4	1/8	1/32	120	28 ins., §
7/8	Cast iron.....	5 ft.	1/8 to 3/16	1/10	56	4 1/2 ins.
1 1/4	Cast iron.....	5 ft.	5/16	1/32	107	6 ins.
1 1/2	Cast iron.....	5 ft.	1/8	1/8	55	8 ins.
1 1/4	Steel, 0.40 C.....	5 3/8 in.	1/8	1/10	90	54 ins.
1 x 2	Steel.....	9 3/4 in.	3/8	1/8	64	72 ins.
1 x 2	Nickel steel.....	3 1/2 in.	1/2	0.072	52	124 ins.
1 1/4	Steel casting, 0.45 C..	20 in.	3/8	1/8	50	15 to 20 min.
1 1/4	Steel, 0.60 C.....	7 1/2 in.	9/64	1/26	115	18 in.

\* Then 1 3/4 in. at 50 ft. per min. † Then 1 1/8 in. at 65 ft. per min.

‡ Then 28 ins. at 98 ft. § Then 22 ins. at 160 ft. || Required 28 H.P.

Chilled rolls, too hard for ordinary high-speed steel, were cut at a speed of 80 ft. per min., with 5/16 in. depth of cut and 1/8 in. feed.

The following results were obtained in drilling:

Drill size.	Material.	Rev. per min.	Feed per rev.	Speed per min.	Drilled without Re-grinding.
3/4 in.	Close cast iron.....	466	0.018	8 1/2 in.	70 holes, 3 ins. deep.
3/4	Steel, 0.25 C.....	247	0.011	.....	60 holes, 2 3/4 ins. deep.
3/4	Hard steel.....	526	.....	6 in.	12 holes, 2 1/2 ins. deep.
13/16	Steel.....	400	.....	3 1/2	14 in. at one operation.

A milling cutter 5 in. diam., with 54 teeth, milling teeth in saw-blanks, at a cutting speed of 56 ft. per min. and a feed of 1 in. per min., cuts 80 blanks (three or more together), each 32 in. diam., 3/8 in. thick, 240 teeth, before re-grinding.

**Stellite.**—An alloy of 25% chromium, 65% cobalt and 10% molybdenum, to which the name "stellite" has been given, is described in *Ir. Tr. Review*, Mar. 5, 1914. This alloy is extremely hard, and retains its hardness even when red hot, thus making it useful as a substitute for tool steel. Tests made with stellite as a cutting tool on various materials showed the following cutting speeds, the speed attained by high-speed steel in the same tests being given for comparison:

Material Cut.	Cutting Speed, Ft. per Min.		Material Cut.	Cutting Speed, Ft. per Min.	
	Stellite.	Steel.		Stellite.	Steel.
Phosphor-bronze...	900	125	Seamless tubing...	400	100
Tool steel.....	133	80	Cast iron.....	200	100

A circular issued by the Midvale Steel Co. gives the following directions for the use of stellite, with a 1/2-in. square lathe tool: For cutting steel of 0.30 carbon or under, the limits will be: Depth of cut, 1/8 in.; feed, 1/16 in. per revolution; speed, 100 to 300 ft. per min., depending on the other conditions. For steel of 0.35 to 1.00 carbon, with the same depth of cut and feed as above the speed should be from 50 to

150 ft. per min. In cutting cast iron it is recommended that light cuts, and heavy feeds, say up to  $\frac{1}{4}$  in., be used. The depth of cut can run to  $\frac{1}{4}$  or  $\frac{3}{8}$  in. under moderate feeds. Stellite cannot be forged, but is cast and ground to shape. It is extremely brittle, and its use is restricted to such tools as can be supported close to the cutting edge. It should not be used when the cut is one that will subject the tool to heavy shocks. The fields for which it is recommended are: For turning steel, where turning represents a large proportion of the work to be done, and where the capacity of the lathe has not been reached with the steel tool; for turning cast iron that is not so hard that a slow speed with a steel tool is necessary, and where the capacity of the machine has not been reached with a steel tool; for inserted teeth in milling cutters and reamers in a limited field where speed is important.

For other data on the heat treatment, forging, etc., of tool steels, see also pages 491 to 497.

### PLANER WORK.

**Work that Should be Planed.**—The planer is adapted for finishing flat surfaces where great accuracy is required. The Cincinnati Planer Co. gives (1912) in "A Treatise on Planing" the following list of work which should be planed: Locomotive frames, cylinders, shoes, wedges, and driving-boxes; printing-press tables, frames, bearings, bases; laundry frames, mangle chests; engine steam chests, valves, frames, pillow blocks, connecting-rods; rolling-mill guides, frames, bearings, keyways, tables; woodworking saw tables, frames, knife arbors, knives, bases; textile machinery frames, guides, bearing stands, legs; electric motor and generator bases and frame segments; forging machinery dies, guides, arches, header frames, bases; machine tool beds, tables, carriages, rails, slides, knees, columns.

**Cutting and Return Speeds.**—A cutting speed of about 55 ft. per minute is about as high as it is practical to use on the planer, and this should be decreased for most materials. The table below shows the speeds recommended by the Cincinnati Planer Co. The lower cutting speed of the planer tool, as compared with the lathe, is probably due to the absence of a cooling lubricant on long cuts. If the cut is intermittent, as in planing a series of castings with gaps in between, the cutting speed can be higher than with a continuous cut of equal total length, probably due to the partial cooling of the tool during the intervals of cutting. Return speeds of 75 to 100 ft. per minute are as high as are recommended, although the author has seen planers operating at a return speed as high as 135 ft. per minute. An increase in the cutting speed is much more effective in increasing the capacity of the machine than an increase in the return speed, and it is better to increase the cutting speed by 25% than to double the return speed.

#### PLANER CUTTING SPEEDS, FEET PER MINUTE.

Iron, cast, roughing. . . . .	40 to 50	Steel, cast, roughing. . . . .	30 to 35
Iron, cast, finishing. . . . .	20 to 25	Steel, cast, finishing. . . . .	20
Iron, wrought, roughing. . . . .	30 to 45	Steel machinery. . . . .	30 to 35
Iron wrought, finishing. . . . .	20	Bronze and Brass. . . . .	50 to 60

**Planer Feeds.**—For rough planing cast-iron feeds range from  $\frac{1}{8}$  to  $\frac{3}{16}$  in.; for steel  $\frac{1}{16}$  to  $\frac{1}{8}$  in. For finishing cast iron with a broad nose tool the feed may range from  $\frac{1}{2}$  to  $\frac{3}{4}$  in. per stroke. The feed should be as heavy as possible, in order to decrease the time required, although when planing to a finished edge, a feed of as low as  $\frac{1}{16}$  in. must be used to avoid breaking the edge at the end of the stroke.

**Power Requirements for Planing.**—The principal power requirement in planing is that required for reversing at the end of the stroke. The largest portion is used in reversing the planer pulleys, which, running at high speeds, store up considerable energy. The substitution of aluminum alloy pulleys by some planer builders for the cast-iron ones usually employed has reduced the power requirements for reversal and has increased the capacity of the machine by increasing the number of strokes which can be made per hour. The Cincinnati Planer Co. (1912) reports that with a 35-ft. cutting speed and an 85-ft. return speed, on a 4-ft. cut, 165 strokes were made in 30 minutes with cast-iron pulleys



and 189 in the same time with aluminum pulleys. In another test, cast-iron pulleys required 39 horse-power at the reverse while aluminum pulleys required 30 horse-power. For other data on power required, see pages 1296, 1302 and 1303.

**Time Required for Planing.**—The Cincinnati Planer Co. has devised a slide rule, shown in Fig. 197, for determining the time required to machine work in a variable speed planer. It is adapted for use with cutting speeds of 20 to 60 ft. per min., return speeds of 50 to 130 ft. per min. and a feed range of from 1/16 to 1 in. per stroke. The feed which is to be used (scale B) is set opposite the intersection of the

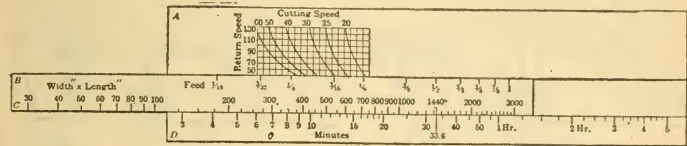

FIG. 197. PLANER TIME SLIDE RULE.

cutting-speed curve with the return speed line (Scale A). The time is read on scale D underneath the figure representing the area in square inches to be planed (width x length) on scale C. To the time so determined must be added the time required for setting up the work in the machine.

The following tables have also been prepared by the Cincinnati Planer Co. for determining times for planer operation.

**Planer Table Travel, Feet per Hour.**

(Divide by length of stroke in feet for number of strokes per hour.)

Speed of Cut, Ft. per Min.	Return Speed, Feet per Minute.							
	50	60	70	80	90	100	120	150
20	857.1	900.0	933.3	960.0	981.8	1000.0	1028.6	1058.8
25	1000.0	1058.8	1105.3	1142.9	1173.9	1200.0	1241.4	1285.7
30	1125.0	1200.0	1260.0	1309.1	1350.0	1384.6	1440.0	1500.0
35	1235.3	1321.3	1400.0	1460.9	1512.0	1555.6	1625.8	1702.7
40	1333.3	1440.0	1527.3	1600.0	1661.5	1714.3	1800.0	1894.7
45	1421.0	1542.8	1643.5	1728.0	1800.0	1862.1	1863.6	2076.9
50	1500.0	1636.4	1750.0	1846.2	1928.6	2000.0	2117.6	2250.0

**Time of Planer Travel per Foot.**

Travel, Ft. per Min.	Seconds per Foot.	Travel, Ft. per Min.	Seconds per Foot.	Travel, Ft. per Min.	Seconds per Foot.	Travel, Ft. per Min.	Seconds per Foot.	Travel, Ft. per Min.	Seconds per Foot.
10	6.0	45	1.33	80	0.75	120	0.5	190	0.316
15	4.0	50	1.2	85	.705	130	.461	200	.30
20	3.0	55	1.09	90	.666	140	.428	220	.273
25	2.4	60	1.0	95	.631	150	.40	240	.25
30	2.0	65	0.923	100	.60	160	.375	260	.23
35	1.72	70	.857	105	.571	170	.353	280	.214
40	1.5	75	.80	110	.545	180	.333	300	.20

**Standard Planer Tools.**—Carl G. Barth designed for the use of the Watertown Arsenal a full line of planer tools, as shown in the drawings, Figs. 198 to 213, and in the tables below. These tools were developed according to the principles discovered by Taylor and Barth in the investigation into the "Art of Cutting Metals" (see p. 1261),

and may be regarded as forming a standard line of tools of the best shape for their respective purposes. They are described in *Am. Mach.*, Jan. 21 and 28, 1915.

**Round Nose Roughing Tools (Dimensions in Inches).**

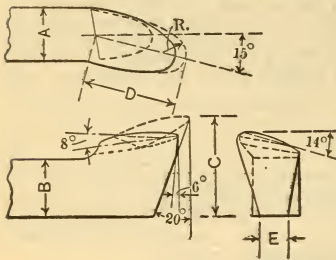

FIG. 198.

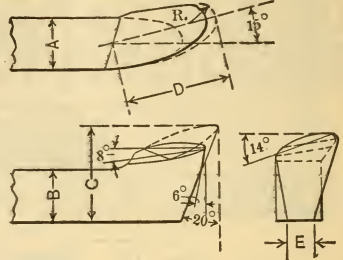

FIG. 199.

**RIGHT OR LEFT HAND (Figs. 198 and 199).**

A	B	C	D	E	R (rad.)
1	1	1 7/8	2	1/2	3/8
1	1 1/2	2 3/8	2	3/8	3/8
1 1/4	1 1/4	2 1/2	2 1/4	5/8	1/2
1 1/4	1 7/8	2 7/8	2 1/4	1/2	1/2
1 1/2	1 1/2	2 1/2	2 5/8	3/4	5/8
1 1/2	2 1/4	3 1/4	2 5/8	5/8	5/8
1 3/4	2 5/8	3 3/4	3 1/8	3/4	3/4

**Parting Tools\* (Dimensions in Inches).**

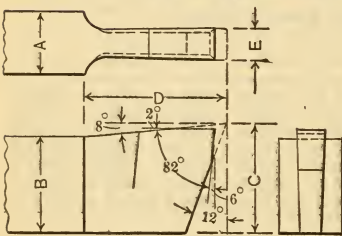

FIG. 200.

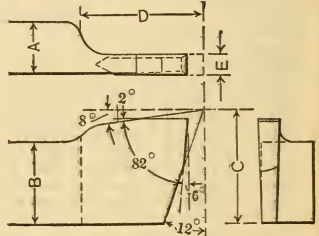

FIG. 201.

**FLUSH NOSE, CENTRAL (Fig. 200).**

**HIGH NOSE, RIGHT HAND, STRAIGHT (Fig. 201).**

A	B	C	D	E
5/8	1	1 1/4	1 3/4	1/4
3/4	1 1/8	1 1/2	2	3/8
1	1 1/2	2	2 1/4	1/2
1 1/4	1 7/8	2 1/2	2	5/8
....	....	....	....	..

A	B	C	D	E
1/2	3/4	1 1/8	1 1/2	1/4
5/8	1	1 3/8	1 5/8	5/16
3/4	1 1/8	1 1/2	1 3/4	5/16
1	1 1/2	2	2	3/8
1 1/4	1 7/8	2 1/8	2 1/2	1/2

**SET BACK NOSE, CENTRAL, STRAIGHT (Fig. 202).**

A	B	C	D	E	F	H
5/8	1	1 3/4	1 1/4	1/4	3	1
3/4	1 1/8	2	1 1/2	5/16	3 1/2	1 1/8
1	1	1 3/4	1 1/2	1/4	3	1
1	1 1/2	2 3/4	2	3/8	4 3/4	1 1/2
1 1/4	1 7/8	3 1/2	2 1/2	1/2	6	1 7/8
1 1/4	1 1/4	2 1/8	1 7/8	3/8	3 3/4	1 1/4
1 1/2	1 1/2	2 5/8	2 1/4	1/2	5	1 1/2

\* See note at foot of page 1273.

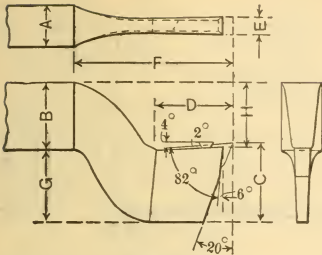

FIG. 202.

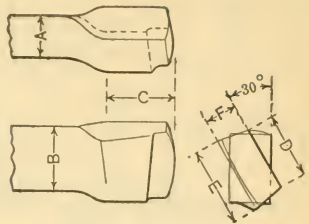

FIG. 203.

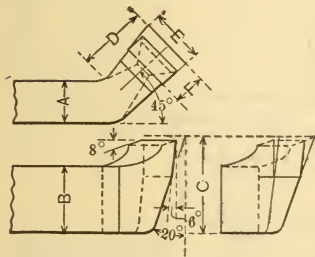

FIG. 204.

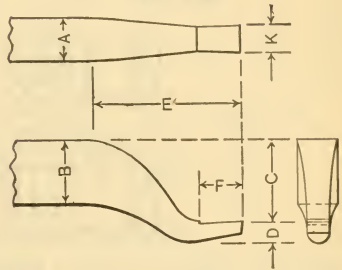

FIG. 205.

**Finishing Tools (Dimensions in Inches).**

**SHEARING CUT (Fig. 203).**

A	B	C	D	E	F
1/2	3/4	3/4	3/4	7/8	7/16
5/8	1	1	1	13/16	9/16
3/4	1 1/8	1 1/8	1 1/8	1 1/2	5/8
1	1 1/2	1 1/2	1 1/2	2	7/8

**SQUARE, HIGH NOSE, BENT 45 DEG. (Fig. 204).**

A	B	C	D	E	F
1	1 1/2	2 1/8	2	1 3/8	3/4
1 1/4	1 7/8	2 7/8	2 1/2	1 3/8	7/8

**External Keyway Tools (Dimensions in In.)**

**SET BACK NOSE (Fig. 205).**

A	B	C	D	E	F	K
1/2	3/4	1	1/4	1 1/2	1/2	Width
5/8	1	1 1/4	5/16	1 3/4	5/8	of
3/4	1 1/8	1 1/2	3/8	2 1/4	3/4	Keyway

**SET BACK NOSE\* (Fig. 206).**

A	B	C	D	E	F	G
3/4	1 1/8	1	1	1 1/4	2 5/8	3/4
1	1 1/2	1 1/4	1 3/8	1 1/2	3 1/2	1
1 1/4	1 7/8	1 5/8	1 3/4	2	4 1/2	1 1/4
1 1/2	2 1/4	2	2	2 1/2	5 1/2	1 1/2

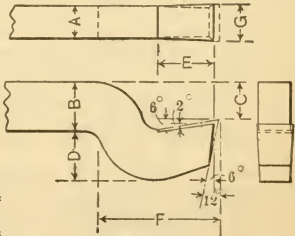

Fig. 206.

\* The sides of the nose of parting tools and external keyway tools with set back nose (Fig. 206) have a taper back from the cutting edge of 1 deg. That is, in the plan each upper edge of the nose tapers inward 1 deg. from a plane parallel to the side of the tool. Each side also tapers downwards from the upper edge 2 degs. from a plane parallel to the side of the tool.



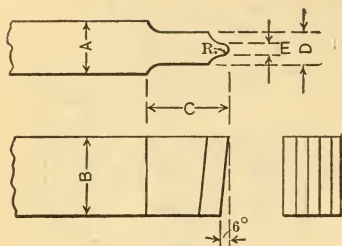

FIG. 207.

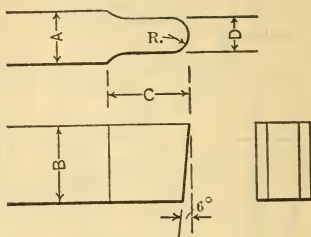

FIG. 208.

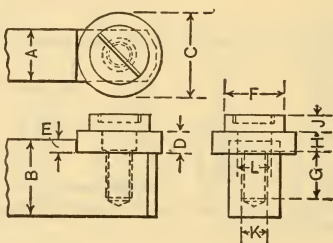

FIG. 209.

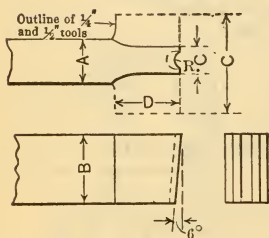

FIG. 210.

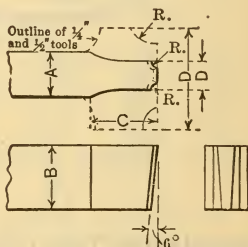

FIG. 211.

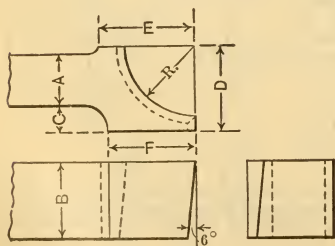

FIG. 212.

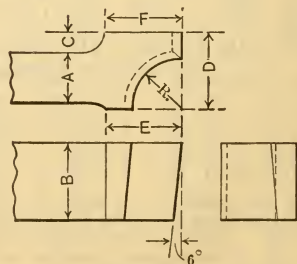

FIG. 213.

**Fillet Forming Tools** (Dimensions in Inches).

180-DEGREE (Fig. 207).						180-DEGREE (Fig. 208).				
A	B	C	D	E	R	A	B	C	D	R
5/8	1	1	1/4	0.04	0.02	5/8	1	1	0.2	0.1
5/8	1	1	3/8	0.10	0.05	5/8	1	1	0.4	0.2
3/4	1 1/8	1 1/4	1	0.80	0.40	..	..	..	..	..

**VARIOUS RADII** (Fig. 209).

Rad.	A	B	C	D	E	F	G	H	J	K	L
5/8	3/4	1 1/8	1 1/4	5/16	3/16	7/8	5/8	1/4	1/4	3/8	1/2
0.8	3/4	1 1/8	1.6	3/8	1/4	7/8	5/8	1/4	1/4	3/8	1/2
1 1/4	1 1/2	2 1/4	2 1/2	7/16	5/16	1 1/8	1	1/4	3/8	1/2	5/8
1 3/4	1 1/2	2 1/4	3 1/2	1/2	3/8	1 1/8	1	1/4	3/8	1/2	5/8

**Radius Forming Tools** (Dimensions in Inches).

180-DEGREE (Fig. 210).					90-DEGREE, RIGHT AND LEFT HAND (Fig. 211).				
R (rad.)	A	B	C	D	R (rad.)	A	B	C	D
1/16	5/8	1	3/8	1	1/32	5/8	1	1	5/16
1/8	5/8	1	1/2	1	1/16	5/8	1	1	3/8
1/4	5/8	1	1	1	1/8	5/8	1	1	1/2
1/2	5/8	1	1 1/4	1	1/4	5/8	1	1	1
....	..	..	....	..	1/2	5/8	1	1	1 1/4

**90-DEGREE, RIGHT HAND OR LEFT HAND** (Figs. 212 and 213).

R (rad.)	A	B	C	D	E	F
3/4	3/4	1 1/8	5/16	1 1/8	1 1/8	1 1/8
1	3/4	1 1/8	3/8	1 1/4	1 3/8	1 1/4
1 1/2	1	1 1/2	5/8	2	2 1/4	2
2	1 1/2	2 1/4	3/4	2 1/2	3	2 5/8

**MILLING MACHINE PRACTICE.**

**Forms of Milling Cutters.**—Milling cutters are made from either high speed or carbon steel. The former can be subjected to the more severe service and are especially adapted to the removal of large amounts of metal, thus dictating their use as roughing cutters. The varieties of cutters in common use and the work to which they are adapted are as follows:

*The Plain Milling Cutter* is a cylinder with teeth on the periphery only, and is used for producing a flat surface parallel to the axis of the cutter. Plain milling cutters are made in a wide variety of diameters and widths for the various requirements of slab milling, keyway cutting, sawing, etc. Cutters less than 3/4 in. wide are usually made with straight teeth, while wider cutters have teeth that are a portion of a spiral. The spiral form enables each tooth to take a shearing cut, reduces the stress on the teeth, and prevents shock as each tooth engages the work, thus producing smoother surfaces on wide work. The spiral cutter requires less power to operate, and as it is under less strain, the tendency to chatter is reduced. Cutters for milling wide surfaces, whether of the spiral or straight type sometimes have nicks cut in the teeth, the nicks being staggered in the consecutive teeth. It is claimed that such cutters can be run with coarser feeds than plain cutters, as the nicks break up the chips and prevent jamming of the teeth. Nicked cutters are condemned by many authorities, however, for the reason that that portion of a following tooth opposite a nick is required to do double the usual amount of work with a resulting tendency to breakage.

*The Side Milling Cutter* is a plain milling cutter with the addition of teeth on both sides. Side milling cutters are used in a large variety of work. Two or more are often placed on the same arbor with a space between them, in which case they are known as straddle mills. Straddle mills are advantageously used where the work has to be milled on two parallel sides, as in bolt heads, tongues, etc. Side milling cutters are often made with interlocking side teeth for milling slots to a standard width, the width of the slot being maintained by means of packing washers between the two parts of the cutter.

*Face Milling Cutters* have teeth cut on the periphery and on one face of a disk. The face mill is fastened to the end of the machine spindle and the teeth on the face come in full contact with the work, only a small portion of the peripheral teeth being in action. Some face mills have no teeth at all on the periphery.

*The End Mill*, like the face mill, has teeth on the periphery and on one end. It is used for light milling operations, such as the milling of slots, facing narrow surfaces, and for making cuts on the periphery of pieces. End mills are of four general types: The solid end mill, the end mill with center cut, the slotting end mill with two lips, and the shell end mill. The first and the last have either straight or spiral teeth. In the solid end mill the teeth are cut in the same piece that forms the shank. The shell end mill has a hole through its center so that it can be mounted on an arbor, and it should be used in preference to the solid mill whenever possible, as it is cheaper to replace when worn out or broken. The teeth of end mills with center cut are designed to cut at the inner end, whereas the teeth of solid mills have no cutting edge at this point. Center cut end mills are used for milling shallow recesses in surfaces where there has been no hole bored previously for starting the cut, for milling squares on the ends of shafts and for similar work. They have fewer teeth and can take heavier cuts than solid end mills or shell end mills. Slotting end mills are adapted to the rapid milling of deep slots from the solid where there has been no hole bored for starting the cut. A depth of cut equal to one-half the diameter of the mill can usually be taken from solid stock.

*The T-Slot* cutter has teeth on its periphery and alternating teeth on its sides, the teeth being cut on the same piece that forms the shank. In making a T-slot, a groove is first cut with an ordinary side milling cutter or a two-lipped end mill, after which the wide groove at the bottom is cut with the T-slot cutter.

*Angular Cutters* have teeth that are at some oblique angle to the axis. The cutter may have more than one angle. They are used for milling the edge of a piece to a required angle, or for cutting teeth in cutters or reamers. In work such as dovetailing where the cutter cannot be fastened to the arbor with a nut, it is made with a threaded hole or with the cutter in one piece with the shank.

*Form Cutters* are of irregular outline for exactly duplicating pieces. In one style of form cutter the teeth are sharpened by grinding on the tops of the teeth, which necessarily changes the contour of the teeth and therefore the outline produced. The usual style is so made that it may be sharpened by grinding the face of the tooth, without altering the contour. This permits the cutter to be used for duplicate interchangeable work until it has been ground to a point where the teeth are too slender to stand the strain of the work.

*Fly Cutters* consist of a single cutter similar in shape to a planer tool, held in and rotated by an arbor. As they have but a single cutting edge, they are used but rarely outside of the experiment room or tool-room. The fly cutter can be formed exactly to any desired shape and will reproduce this shape exactly. Its field is those operations that would not bear the expense of special shaped commercial cutters, as where but one or two teeth are to be made of a special form.

*Inserted Tooth Cutters.*—When it is required to use plain milling cutters of a greater diameter than about 8 in., or side milling cutters of greater than 6 in. diameter, it is preferable to insert the teeth in a disk or head, so as to avoid the expense of making solid cutters and the difficulty of hardening them, not merely because of the risk of breakage in hardening them, but also on account of the difficulty in obtaining a uniform degree of hardness or temper. The face of the inserted tooth should be undercut a few degrees from the radial line, thereby giving a smoother cut and consuming less power than would be the case were the face of the tooth flush with the radial line. Drawings of inserted tooth cutters furnished the author by the Cincinnati Milling Machine Co., show a rake of the teeth of from 10 to 15 degrees.

**Number of Teeth.**—There is no standard rule for the number of teeth in milling cutters. The sizes offered commercially by cutter manufacturers have been found as a rule satisfactory for most purposes,



but in roughing out work where as much metal is to be removed as possible in a given time, cutters with a smaller number of teeth than the standard mills are advisable. Furthermore, a short lead spiral on coarse tooth cutters adapts them to a large range of work that is not in the heavier class. Such cutters show a considerable saving of power over cutters with a larger number of teeth. The number of teeth in cutters of various types is given in *Machinery*, April, 1907, as follows:

Plain milling cutters are usually manufactured in sizes from 2 to 5 in. diameter, and up to 6-in. face. The use of solid plain milling cutters of over 5-in. face is not advised, and cutters over 5-in. face should be made in two or more interlocking sections.

NUMBER OF TEETH AND AMOUNT OF SPIRAL OF PLAIN MILLING CUTTERS

$$\text{No. of teeth} = \frac{5 \times \text{diam.} + 24}{2}; \text{Length of Spiral} = 9 \times \text{diam.} + 4.$$

Diameter of cutter,

2 2 1/4 2 1/2 2 3/4 3 3 1/2 4 4 1/2 5 5 1/2 6 6 1/2 7 7 1/2 8

Number of teeth,

16 18 18 18 20 20 22 24 24 26 26 28 30 30 32

Length of one turn of spiral, inches,

22 24 1/4 26 1/2 28 3/4 31 35 1/2 40 44 1/2 49 53 1/2 58 62 1/2 67 71 1/2 76

A cutter with an included angle of 60° (12° on one side and 48° on the other) is recommended for fluting plain milling cutters, although cutters of 52° (12° and 40°) are commonly furnished by manufacturers. The angle of relief of milling cutters should be between 5° and 7°.

The teeth of side milling cutters should have the same general form as those of plain milling cutters, excepting that the cutter used to form them should have an included angle of about 75°.

NUMBER OF TEETH IN SIDE MILLING CUTTERS.

$$\text{Number of teeth} = 3.1 \text{ diam.} + 11.$$

Diameter of cutter,

2 2 1/4 2 1/2 2 3/4 3 3 1/2 4 4 1/2 5 5 1/2 6 6 1/2 7 7 1/2 8 9

Number of teeth,

18 18 18 20 20 22 24 24 26 28 30 32 32 34 36 38

**Keyways in Milling Cutters.**—A number of manufacturers have adopted the keyways shown below, as standards. The dimensions in inches are given in the tables.



FIG. 214.—SQUARE KEYWAY.



FIG. 215.—HALF-ROUND KEYWAY.

SQUARE KEYWAYS.

Diam. Hole,	3/8-9/16	5/8-7/8	15/16-1 1/8	1 3/16-1 3/8	1 7/16-1 3/4	1 13/16-2	2 1/16-2 1/2	2 9/16-3
Width W	3/32	1/8	5/32	3/16	1/4	5/16	3/8	7/16
Depth, D	3/64	1/16	5/64	3/32	1/8	5/32	3/16	3/16
Radius, R	0.020	0.030	0.035	0.040	0.050	0.060	0.060	0.060

HALF-ROUND KEYWAYS.

Diam. Hole, H	3/8-5/8	1 1/16-1 3/16	7/8-1 3/16	1 1/4-1 7/16	1 1/2-2	2 1/16-2 7/16	2 1/2-3
Width W	1/8	3/16	1/4	5/16	3/8	7/16	1/2
Depth, D	1/16	3/32	1/8	5/32	3/16	7/32	1/4

**Diameter of Cutters.**—It is advisable to use cutters of as small a diameter as the strength will admit. The smaller the cutter, the shorter the distance it will have to travel in milling a given length. With small mills also there is less liability to chatter than with large ones. In addition they require less power and are not as expensive as large ones. The Brown & Sharpe Mfg. Co. states that a difference of  $\frac{1}{2}$  in. in the diameter of the mills made a difference of 10% in the cost of their work. In surface milling the cutter should, if possible, be wider than the work.

**Clearance and Rake of Cutters.**—The clearance of milling cutters, or the amount of material removed from the top of the teeth back of the cutting edge to permit it to clear the surface of the work instead of scraping over it, depends on the diameter of the cutters. It must be greater for small cutters than for large ones. For plain cutters over 3 in. diameter, the clearance angle should be 4 degrees, and for cutters of less than 3 in. it should be 6 degrees. For end mills it should be about 2 degrees. It is considered advisable to have the teeth of end mills from 0.001 to 0.002 in. lower at the center than at the outside. The Cincinnati Milling Machine Co. has furnished the author with drawings of cutters of various types. In these the teeth have a front rake of 10 degrees..

**Power Required for Milling.** (*Mech. Engr.*, Oct. 26, 1907.)—Mr. S. Strieff made a series of experiments to determine the power required to drive milling cutters of high-speed steel. The results are shown in the table below. A proportionately higher amount of power is required for light than heavy milling, as the power to drive the machine is the same at all loads. The table also shows that the depth of cut does not increase the power required in the same proportion as the width, and that work with a quick feed and a deep but comparatively narrow cut requires less power than a wide cut of moderate depth with slow feed, the amount of metal removed being the same in both cases.

**Power Required for Milling.**

Number of Revolutions of Cutter per Minute.	Feed.		Cutting Speed of Cutter, Ft. per Minute.	Depth of Cut, Inches.	Width of Cut, Inches.	Horse-Power Required.	Metal Removed per Hour, Pounds.	Horse-Power Required per Pound-Hour.
	Per Min- ute, In- ches.	Per Rev- olution, Inches.						
24	2.46	0.10	37	0.26	23.6	25	245	0.102
24	3.50	0.15	37	0.26	10.2	17	150	0.113
24	4.35	0.18	37	0.14	9.8	17	97	0.175
24	3.50	0.15	37	0.49	9.8	27	490	0.055
19	4.33	0.23	29.5	0.28	9.3	17	331	0.051
23	4.17	0.18	36	0.28	20.5	27	386	0.070
23	4.17	0.18	36	0.28	9.8	20	183	0.109
40	1.89	0.05	64	0.24	10.2	17	74	0.230
40	3.94	0.10	64	0.37	13.8	21	331	0.063
40	5.79	0.14	64	0.16	16.5	17	123	0.138

P. V. Vernon reports (*En'gr.*, Mar. 9, 1909) some milling machine tests made by Alfred Herbert, Ltd., showing the horse-power required to slab mild steel and cast iron. The tests reported include 44 on steel and 38 on cast iron. The horse-power was determined from the current readings and includes the motor losses and also a constant loss of 1.8 H.P. in the jack shaft and countershaft of the machine.

**HORSE-POWER PER CU. IN. PER MINUTE REQUIRED FOR SLABBING.**

	Maximum.	Minimum.	Average.
Steel.....	3.02	1.95	2.52
Cast iron.....	1.25	0.89	1.10

Later tests reported to the Manchester Assoc. of Engrs., Nov. 23, 1912, by Mr. Vernon, embodied the following conclusions: (1) A 5-in. double belt, driving a 16-in. pulley at 400 r.p.m. (100,531 sq. in. of

belt per min.) geared to drive 4½-in. high-speed cutter at 70 ft. per min. is able to remove as much as 48.1 cu. in. of cast iron or 24.31 cu. in. of mild steel per minute. (2) 2090 sq. in. of double belt passing over a pulley per minute will remove 1 cu. in. of cast iron in a milling machine. To remove 1 cu. in. of steel the belt surface passing should be 4135 sq. in. (3) A 4½-in. high-speed cutter on a 2-in. arbor, running at 70 ft. per min. is capable of removing at least 3.63 cu. in. of cast iron, and possibly as much as 6.01 cu. in., and at least 2.125 cu. in. of mild steel, and possibly as much as 3.03 cu. in. per min. for each inch of width of belt, up to 8 in. From the earlier tests noted above the conclusion was reached that 1 H.P. would remove as much as 1.84 cu. in. of cast iron per min., and 0.74 cu. in. of mild steel. In these tests the feed in cast iron ranged between 1<sup>27</sup>/<sub>32</sub> and 10<sup>9</sup>/<sub>16</sub> in. per min., the depth of cut from 0.14 to 1.10 in., while in steel the feeds ranged from 5/8 to 10<sup>3</sup>/<sub>8</sub> in. per min. and the depth of cut from 0.10 to 1.10 in. per min.

A. L. De Leeuw gives in *Am. Mach.*, Aug. 8, 1912, the results of a large number of tests to determine the horse-power consumed in cutting machinery steel in the milling machine. From the tests there reported the following table has been compiled, the figures given showing the test in each class in which the maximum amount of metal per horse-power per minute was removed. The figures for horse-power are net, the motor losses having been deducted.

**Power Required for Milling Machinery Steel (A. L. De Leeuw).**

Depth of Cut, In.	R.P.M. of Cutter.	Feed, In. per Minute.	Horse-Power.	Cu. In. of Metal Removed per H.P.-Min.	Cutter (Note 1).	Material (Note 2).	Depth of Cut, Inches.	R.P.M. of Cutter.	Feed, In. per Minute.	Horse-Power.	Cu. In. of Metal Removed per H.P.-Min.	Cutter (Note 1).	Material, (Note 2).
1/8	20.5	12.31	10.96	0.702	1	B	5/16	20.0	4.57	11.959	0.712	1	A
"	25.0	15.4	13.473	0.714	1	A	"	20.0	4.56	7.34	0.972	1	A
"	20.0	11.81	7.555	0.977	1	A	"	21.5	4.89	7.14	1.07	1	C
"	20.0	11.83	7.34	1.007	1	A	"	16.0	7.70	11.0	1.092	2	D
"	22.0	12.96	6.85	1.183	1	C	3/8	20.0	3.48	10.96	0.596	1	B
3/16	20.0	7.34	10.70	0.643	1	B	"	20.0	3.49	7.07	0.925	1	A
"	20.0	7.29	9.749	0.701	1	A	"	40.5	6.22	12.35	0.944	3	D
"	20.0	7.29	7.07	0.967	1	A	"	40.	7.8	14.55	1.001	3	D
"	21.5	7.96	6.85	1.09	1	C	"	22.	3.86	6.85	1.056	1	C
1/4	20.0	5.9	12.62	0.584	1	B	"	15.75	7.66	12.64	1.137	2	D
"	20.0	5.84	11.41	0.64	1	A	1/2	15.5	4.61	12.64	0.912	2	D
"	19.0	5.58	7.62	0.915	1	A	"	40.0	6.09	15.93	0.955	3	D
"	21.5	6.26	7.14	1.096	1	C	5/8	40.0	4.71	17.07	0.863	3	D
5/16	20.5	4.68	13.20	0.554	1	B	3/4	39.5	3.63	17.38	0.782	3	D

NOTE 1.—Cutter No. 1 is an 8-in., 12-blade face mill; No. 2 is a 10-in., 16-blade high-power face mill; No. 3 is a 4½ in., 10-tooth spiral nicked cutter.

NOTE 2.—Material A, Elastic Limit 36,400 lb. per sq. in., elongation 36%, reduction of area 66%; material B, E. L. 36,200 lb. per sq. in., elong. 36.5%, red. of area 59.6%; material C, E. L. 37,400 lb. per sq. in., elong. 36.5%, red. of area 60%; material D, E. L. 55,000 lb. per sq. in., elong. and red. of area not given; 0.26 carbon, 0.5% manganese.

**Modern Milling Practice (1914).**—The limit of milling operations is determined by the strength and durability of the cutter. A rigid frame on the machine and powerful feed mechanism increase these. The chief causes of low output are: Improperly constructed cutters; insufficient rigidity in the machine; and timidity, due to lack of experience, of both builders and operators. The principal cause of cutter failures is insufficient space for chips between the cutter teeth. Fixed rules cannot be laid down for proper feeds and speeds of milling cutters, these depending on the character and hardness of the metal



being cut. On roughing cuts it is desirable to run the cutter at a speed well within its limit, and use as heavy a feed as the machine can pull. The size of chip taken by each tooth of the cutter with the heaviest feeds is comparatively light, and with properly sharpened cutters there is little danger of breaking the cutter by giving too great a feed. It is considered better practice, however, to break an occasional cutter than to run machines at a low rate. It is not considered desirable to run even high speed steel cutters at excessive speeds. The great value of these cutters is their long life and ability to hold a cutting edge as compared with carbon steel cutters. It is important to keep the cutters sharp, as accurate or fast work is impossible with dulled teeth, and a dull cutter will wear away faster than a sharp one. Cutter grinders should always be used for sharpening cutters.

The following speeds in feet per minute are a good basis for roughing the materials indicated:

Carbon steel cutters,	Cast Iron.	Machinery Steel.	Tool Steel.	Brass and Bronze.
	40 to 60	30 to 40	20 to 30	80 to 100
High speed steel cutters,	80 to 100	80 to 100	60 to 80	150 to 200

On cast-iron work a jet of air delivered to the cutter with sufficient force to blow the chips away as fast as made permits faster feeds and prolongs the cutter's life. A stream of oil fed under heavy pressure to wash the chips away has the same effect when cutting steel. On finishing cuts the rate of feed used determines the grade of the finish. If a spiral mill is used the feed should range from 0.036 in. to 0.05 in. per revolution of a 3-in. diameter cutter. As such cuts are light the speed of cutting can be much higher than that used for roughing cuts. The nature of the cut is a factor in determining speeds; a saw can run twice as fast as a surface mill. (See paragraph, p. 1282, on high-speed milling.) Keyseating and similar work can be best done with a plain cutter rather than a side mill.

Castings should be pickled in a solution of sulphuric acid, diluted with water to a specific gravity of 25 deg. (Baumé), before milling, to remove the hard skin and sand which are destructive to cutters. If the castings are later to be painted, they should not be immersed in the pickling bath. It is better to pour the solution over them, allowing it to dry before making another application. This should be repeated 4 or 5 times. Forgings should be pickled in a solution of sulphuric acid and water of a specific gravity of 30 deg. (Baumé), for from 3 to 12 hours. After pickling, forgings and castings should be washed with hot water to remove the sand and acid.

**Milling "with" or "against" the Feed.**—Tests made with the Brown & Sharpe No. 5 milling-machine (described by H. L. Arnold, in *Am. Mach.*, Oct. 18, 1884) to determine the relative advantage of running the milling cutter with or against the feed—"with the feed" meaning that the teeth of the cutter strike on the top surface or "scale" of cast-iron work in process of being milled, and "against the feed" meaning that the teeth begin to cut in the clean, newly cut surface of the work and cut upwards toward the scale—showed a decided advantage in favor of running the cutter against the feed. The result is directly opposite to that obtained in tests of a Pratt & Whitney machine by experts of the Pratt & Whitney Co.

In the tests with the Brown & Sharpe machine the cutters used were 6 inches face by  $4\frac{1}{2}$  and 3 inches diameter, respectively, 15 teeth in each mill, 42 revolutions per minute in each case, or nearly 50 feet per minute surface speed for the  $4\frac{1}{2}$ -inch and 33 feet per minute for the 3-inch mill. The revolution marks were 6 to the inch, giving a feed of 7 inches per minute, and a cut per tooth of 0.011 inch. When the machine was forced to the limit of its driving the depth of cut was  $\frac{11}{32}$  inch when the cutter ran in the "old" way, or against the feed, and only  $\frac{1}{4}$  inch when it ran in the "new" way, or with the feed. The endurance of the milling cutters was much greater when they were run in the "old" way. The Brown & Sharpe Mfg. Co. says that it is sometimes advisable to mill with the feed, as in surfacing two sides of a piece with straddle mills, the cutters will then tend to hold the work down. In milling deep slots or cutting off stock with thin cutters or saws, milling with the feed is less likely to crowd the cutter sidewise and make a crooked slot.

**Lubricant for Milling Cutters.** (Brown & Sharpe Mfg. Co., 1907.)—An excellent lubricant, to use with a pump, for milling cutters is made by mixing together and boiling for one-half hour,  $\frac{1}{4}$  lb. sal soda,  $\frac{1}{2}$  pint lard oil,  $\frac{1}{2}$  pint soft soap and water enough to make 10 quarts. Oil is also frequently used in milling steel, wrought iron, malleable iron or tough bronze.

**Typical Milling Jobs—Speeds—Feeds.**—The notes below compiled from data furnished by the Brown & Sharpe Mfg. Co. and the Cincinnati Milling Machine Co. (1915) show examples of what is considered good commercial milling practice.

Bars of 0.60 Carbon steel,  $\frac{5}{8}$  in. thick,  $2\frac{1}{2}$  in. wide,  $11\frac{3}{4}$  in. long, had 22 rack teeth,  $\frac{7}{16}$  in. pitch and  $\frac{1}{8}$  in. deep milled in the edge. The bars were locked four at a time in a vise. A gang of four cutters was used, at 41 r.p.m. and a feed of 0.023 in. per revolution, equivalent to  $\frac{15}{16}$  in. per minute. Two vises were used, the operator loading one while the bars in the other were being machined. The time required per piece including chucking and removing, was 0.71 minute. For milling two recesses in the upper edges of these same bars, after the rack teeth were cut, they were mounted two in a vise with distance pieces between, and a gang of four  $3\frac{1}{2}$ -in. side mills was used, milling all four recesses at once. The mills rotated at 50 r.p.m., and the feed was 0.068 per revolution, equivalent to 3.4 in. per minute. Two vises were used as before, and the total time per rack was 2.2 minutes. The final operation was the milling of a slot in the bar, for which purpose it was held at the ends in two vises. Two holes were first drilled in the piece through one of which the cutter was threaded. The slot was 1-in. wide and 9 in. long. A  $\frac{15}{16}$ -in. helical cutter was used at 160 r.p.m. A roughing cut was first taken at a feed of 0.015 per revolution, equivalent to 2.4 in. per min., after which the piece was removed and allowed to cool before the finishing cut was taken at a feed of 0.068 in. per revolution, or 10.8 in. per minute. The roughing cut removed  $\frac{1}{2}$  cu. in. of steel per minute. The total time, including chucking, removing, etc., was 7.5 minutes.

Gray iron castings  $8\frac{1}{4}$  in. long,  $8\frac{1}{2}$  in. wide,  $4\frac{1}{4}$  in. thick, with two flanges  $\frac{7}{8}$  in. high and  $\frac{7}{8}$  in. thick projecting above the upper face, were milled on the entire upper surface and the two sides, including top and sides of flanges at one operation by a gang of straddle mills, the largest cutter being  $10\frac{1}{2}$  in. diameter and running at 21 r.p.m., with 6.3 in. feed per minute. Metal was removed at the rate of 19 cu. in. per minute, the maximum depth of cut being  $\frac{3}{16}$  in. The pieces were held in a string jig, removed as fast as they were traversed by the gang of cutters, and others were chucked in their places. They were milled in lots of 125 without resharpening of the cutters. Time per piece, 2 minutes.

A gray iron casting 22 in. wide and 9 in. long was milled on its upper surface by a gang of three 6-in. spiral mills with a total face width of 24 in., mounted on a 2-in. arbor. The depth of cut was  $\frac{3}{8}$  in. and the table feed was  $7\frac{3}{4}$  in. per minute.

A surface about 1 in. wide all around an aluminum transmission case  $12 \times 14$  in. was milled by means of a  $10\frac{1}{2}$ -in. inserted tooth face mill at 236 r.p.m. Depth of cut,  $\frac{1}{8}$  in., table feed, 0.068 in. per revolution or 20 in. per minute. A double fixture was used, one piece being inserted while the other was being milled. Time, including chucking and removal,  $2\frac{1}{2}$  minutes per piece.

Gray iron castings,  $10\frac{1}{4}$  in. wide, 14 in. long  $\times$   $1\frac{3}{4}$  in. thick, finished all over, and a slot  $\frac{5}{8} \times 1$  in. cut from the solid. A gang of five cutters was used, two of 8 in., two of  $3\frac{1}{2}$  in. and one of  $5\frac{3}{4}$  in. diameter, respectively. These took a cut  $\frac{3}{16}$  in. deep across the top, and two edges, and milled the slot in one operation. The table travel was 4.2 in. per minute. The average time, including chucking, was 15.6 minutes.

Gray iron castings, 3 in. and  $6\frac{1}{2}$  in. wide  $\times$   $25\frac{1}{4}$  in. long,  $1\frac{1}{4}$  in. thick, were surfaced by a face mill 8 in. diameter at a surface speed of 80 feet per minute. The cut was  $\frac{3}{16}$  in., and the table travel 11.4 in. per minute in the 3-in. part and 8 in. per minute in the  $6\frac{1}{2}$ -in. part. The total time for finishing, including chucking, was seven minutes. The planer required 23 minutes for the same operation. In finishing

the opposite side of these castings, two castings were milled at one setting,  $\frac{3}{16}$  in. of stock being removed all over and two slots  $\frac{5}{8} \times \frac{5}{8}$  in. milled from the solid. A gang of seven cutters, 3 of 3 in., 2 of  $4\frac{1}{4}$  in., and 1 of  $8\frac{1}{4}$  in. diameter was used at 38 r.p.m. and a feed of 0.1 in., giving a table travel of 3.8 in. per minute. These two castings were finished in 18 minutes, including chucking, the actual milling time being eight minutes on each piece. A planer working at 55 ft. cutting speed finished the same job in 36 minutes.

An inserted-tooth face mill 12 in. diameter took a 9-in. cut,  $\frac{1}{8}$  in. deep across the entire face of a gray iron casting at a table travel of 5 in. per minute. The length of cut was 18 in. and the time required  $6\frac{1}{2}$  minutes.

The following table summarizes a number of typical jobs of milling:

### Typical Milling Jobs.

Nature of Work.	Material Cut.	Cut, In.		Cutter.		Surface Speed, Ft. per Min.	Feed per Rev., In.	Table Travel, In. per Min.	Metal Removed per Min., Cu. In.
		Deep.	Wide.	Diam., In.	R.P.M.				
Face Milling	Cast Iron	$\frac{1}{8}$	6	8	26	54	0.168	4.36	3.27
"	"	$\frac{1}{8}$	8	9.5 <sup>1</sup>	26	64	0.58	15.0	15.0
"	"	0.150	8	9.5 <sup>1</sup>	24	60	0.625	15.	18.0
"	Mall. Iron	$\frac{1}{16}$ - $\frac{3}{32}$	6 <sup>2</sup>	7.5	56	110	0.223	12.5	.....
"	Steel <sup>3</sup>	$\frac{7}{16}$ <sup>2</sup>	5	6 <sup>1</sup>	32	50	0.148	4.75	9 <sup>2</sup>
"	" <sup>6</sup>	$\frac{1}{8}$	6	9.5 <sup>1</sup>	24	60	0.52	12.5	9.375
Surfacing	Cast Iron	$\frac{1}{32}$	3	4	68	71	0.18	12.75	1.75
"	"	0.1	12	4.5 <sup>4</sup>	45	52	0.266	12.0	14.4
"	"	0.1	4	3 <sup>5</sup>	104	81	0.144	15.0	6.0
"	"	$\frac{1}{8}$	4	3 <sup>5</sup>	104	81	0.078	8.125	4.06
"	"	$\frac{1}{8}$	8	3.5 <sup>5</sup>	90	83	0.167	15.0	15.00
"	"	$\frac{1}{8}$	12	3.5 <sup>4</sup>	53	55	0.226	12.0	14.4
"	"	0.225	8	3.5 <sup>5</sup>	85	77	0.118	10.0	18.0
"	"	$\frac{1}{4}$	8	3.5 <sup>5</sup>	81	75	0.154	12.5	25.0
"	"	$\frac{1}{4}$	8	3.5 <sup>5</sup>	94	86	0.159	15.0	30.0
"	Tool Steel	$\frac{1}{16}$	2 $\frac{1}{2}$	3 <sup>7</sup>	37	29	0.05	1.85	0.289
"	Steel <sup>6</sup>	0.1	6	3 <sup>5</sup>	104	81	0.037	3.875	2.32
"	" <sup>6</sup>	0.15	6	3 <sup>5</sup>	104	81	0.037	3.875	3.48
"	" <sup>6</sup>	0.166	6	3.5 <sup>5</sup>	90	83	0.083	7.5	7.5
"	" <sup>6</sup>	0.222	6	3.5 <sup>5</sup>	105	96	0.071	7.5	10.0
"	" <sup>6</sup>	0.240	6	3.5 <sup>5</sup>	94	86	0.133	12.5	18.0
"	" <sup>6</sup>	0.311	6	3.5 <sup>5</sup>	100	92	0.075	7.5	14.0
"	Brass	0.01	2 $\frac{1}{2}$	3 <sup>7</sup>	100	78	0.25	25.0	0.675
"	Bronze	$\frac{1}{64}$	3	3 <sup>8</sup>	166	130	0.05	8.3	0.389
T-Slotting	Cast Iron	See Note <sup>9</sup>	te <sup>9</sup>	$1\frac{1}{16}$	252	75	0.05	12.6	6.693
Slotting <sup>10</sup>	Steel	.....	$1\frac{3}{16}$	1.5 <sup>11</sup>	163	65	0.007	1.25	2.2
Sawing	"	.....	$\frac{3}{64}$	5	70	91	0.05	3.5	.....

<sup>1</sup> Inserted teeth, high-speed steel. <sup>2</sup> Maximum. <sup>3</sup> Chrome nickel steel. <sup>4</sup> Carbon steel, nicked spiral cutter. <sup>5</sup> High-speed steel, spiral nicked cutter. <sup>6</sup> Machinery steel, tensile strength, 65,000 lb. <sup>7</sup> End mill. <sup>8</sup> End mill with spiral teeth; work done by peripheral teeth. <sup>9</sup> Both sides of cutter engaged, making slot width equal to cutter diameter; slot  $1\frac{1}{16} \times \frac{1}{2}$  in. <sup>10</sup> Milling slots from solid plate  $\frac{3}{16}$  in. thick. <sup>11</sup> Helical end mill, front of which is formed as a regular twist drill. Operator first drills through the plate with it, and then uses it as a milling cutter.

**High Speed Milling.**—L. P. Alford describes (*Am. Mach.*, April 16, 1914) a system of high-speed milling developed by the Cincinnati Milling Machine Co., which permits of cutter speeds and feeds from 8 to 12 times as great as are ordinarily used. The fundamental condition for this practice is the provision of ample lubrication of the



cutter and work. The cutter is deluged with about 12 gal. per minute of lubricant, which is delivered through a hood which completely surrounds the cutter. The lubricant is delivered under pressure, and in addition to cooling the cutter and work, washes away the chips from the teeth of the cutter, preventing them from being carried back into the cut, clogging it, dulling the cutter and marring the finished surface. Other requisites for high-speed milling are powerful, heavy and rigid machines, and cutters with wide spaced teeth which will permit the use of heavy feeds and high speeds. The following tests were cited to show what is possible with this system of milling. The material cut was machinery steel, 0.2 carbon, 0.5 manganese, with a tensile strength of 55,000 to 65,000 lb. per sq. in. The cutters were of high speed steel.

### Data and Results of High Speed Milling Tests.

Test.	Cutter.						Arbor Diam., In.	Cut.			Cutter Speed.		Feed, In. per Min.
	Type, See Note.	Angle, Degree.	Diam., In.	No. of Teeth.	Rake, Degree.	Length, In.		Depth	Width.	Length.	R.P.M.	Ft. per Min.	
1	S	25	3 1/2	9	10	6	1 1/2	1/8	5	18	500	458	30 1/2
2	S	25	3 1/2	9	10	6	1 1/2	0.02	5	18	500	458	7.23
3	H	69	3 1/2	3	15	6	1 1/2	{ 1/16 } { 3/16 }	.....	.....	510	470	30 1/2
4	L	....	6 5/16	16	15	1	1 1/2	{ 3/16 } { 1/4 }	.....	.....	510	835	30 1/2
5	G	7 <sup>1</sup>	3 1/2	12	10	....	1 1/4	{ 7-Tooth } { 30-Pitch } Gear.	..	18 1/4	218	200	112
6 <sup>2</sup>	S	25	3 1/2	9	10	6	1 1/2	1/4	5	2 1/2	87	80	20

<sup>1</sup> Diametral Pitch. <sup>2</sup> Same cutter and block as in Test No. 1, but run without lubricant. Test stopped when cutter showed signs of distress after cutting 2 1/2 in. Edges of teeth blued.

NOTE.—S, spiral mill; H, helical mill; L, slotting cutter; G, gear cutter.

As a criterion of the life of cutters under the above conditions, a cutter of the type used in test No. 5, was run to destruction. It milled 6700 in., not including cutter approach, the equivalent of cutting 223 gears of 1-in. face, 7 pitch, 30 teeth.

**Limiting Factors of Milling Practice.**—Discussing the above tests Mr. Alford gives the following as the limiting factors of milling machine practice: (1) Power of the machine. Increased speed requires greater power per cubic inch of metal removed; according to the Cincinnati Milling Machine Co., doubling the speed necessitates a 10% increase of power per cubic inch of metal removed. (2) Ability of the cutter to remove metal. Increased speed, with the same feed increases the ability of the cutter to cut, due to the smaller chip removed by each tooth. This means a decrease of strain, wear and heating effect. The total or final heating effect is increased, but this may be counteracted by copious lubrication. (3) Size and spring of arbor. The size of the arbor is limited by the size of commercial cutters. The strain on the arbor depends on the feed per minute. An increase of speed, lessening the pressure per tooth, reduces the arbor strain, and tends to do away with the limitation imposed by the arbor. (4) Heating of the cutter, often the most important limitation. This can be overcome by sufficient lubricant to remove all heat as fast as it is generated. (5) Wear of the cutter. This is dependent on the number of lineal inches milled, depth of cut and feed per revolution being constant. Increased speed increases the wear per unit of time. Wear may be somewhat reduced with high speed by copious lubrication which washes away the chips, thus preventing the grinding action due to cutting up chips. (6) Breakage of cutters. Frail cutters limit production, as only a certain maximum feed per revolution, dependent on their

strength, can be taken. Increased speed, with constant feed, will increase production without increasing the cutter strain or danger of breakage. (7) Heating of work. Uneven local heating when milling will produce uneven surfaces, for the swelled portions will be cut away. This action is progressive as the total heat increases as the cut advances. The absence or prevention of heating by copious lubrication does away with this limitation. (8) Spring of work. This limitation is minimized for the same reasons given in (6). (9) Spring of fixture. The same analysis applies as in (6). If the pressure per tooth is reduced, the pressure for holding may be reduced, and clamping fixtures may be made to operate more quickly. An increase in cutting speed therefore will tend to increase the speed of operation of the clamping devices and fixtures. (10) Spring of the machine. The same arguments apply as in (9). (11) Distance of revolution marks on the work. This is the limiting feature in perhaps 90% of milling work, which is governed by polishing or some subsequent operation. If the marks are far apart, polishing cannot be satisfactorily done. Increased speed, with constant feed will bring these marks closer together. (12) Smoothness of cut. High speed milling, both by the action of centrifugal force and by copious flooding removes the chips completely from the cutter and eliminates the grinding effect on the finished surface. With a given distance between revolution marks, high speed will give a smoother surface.

**Speeds and Feeds for Gear Cutting.**—The speeds and feeds which can be used in gear cutting are affected by many variables, among which may be noted: The material and shape of the cutter, the latter condition involving both the strength and the ability of the teeth to clear themselves of chips; the material and shape of the gear, shape influencing the speed and feed in that a heavy rugged gear will permit higher speeds and heavier feeds, even in hard material than will a light springy one; accuracy of finish required; quality of lubricant used; rigidity of machine. The following table shows tentative speeds recommended by Gould and Eberhardt, which may serve as a preliminary guide, pending the determination of the best combination for each particular case. They represent average practice in medium grades of cast iron and steel.

	High-Speed Steel Cutters.			Carbon Steel Cutters.		
	Min.	Max.	Average.	Min.	Max.	Average.
Cast iron, ft. per min..	60	70	80	35	60	45
Steel, ft. per min.....	45	50	55	25	40	30

The feeds in inches per minute recommended by the same company, depend on the capacity of the machine and on the size of the teeth. Thus, in a machine whose maximum capacity is for gears with teeth of one diametral pitch in cast iron and of  $1\frac{1}{4}$  diametral pitch in steel, the feeds range from 2.3 in. per minute in cast iron for gears of 1 diametral pitch to 6.9 in. for gears of 6 diametral pitch, carbon steel cutters being used. For high-speed steel cutters, the corresponding figures are 3.5 and 11.0 in. In steel, the feeds under the same conditions are 1.9 in. and 4.5 in. per minute with carbon steel cutters and 2.8 in. and 6.9 in. per minute with high-speed steel cutters. Likewise in a machine whose maximum capacity is teeth of 4 diametral pitch for cast iron gears and 5 diametral pitch for steel gears, the feed given for carbon steel cutters for gears of 4 diametral pitch is 2.6 in. per minute in cast-iron and 1.5 in. per minute in steel. For gears of 24 diametral pitch the figures are for cast iron 7.6 in. per minute, and for steel 5.8 in. per minute. Using high-speed steel cutters, the corresponding figures are: 4 diametral pitch, cast iron 4.5 in. per minute; steel, 3.5 in. per minute; 24 diametral pitch, cast iron 10 in. per minute; steel, 7.6 in. per minute. These figures merely show the range of feeds that are possible in gear cutting, and the tables furnished by the manufacturers of gear-cutting machines should be consulted for the proper feeds for particular cases.

**DRILLS AND DRILLING.**

**Constant for Finding Speeds of Drills.**—For finding the speed in feet when the number of revolutions is given; or the number of revolutions, when the speed in feet is given.

Constant =  $12 \div (\text{size of drill} \times 3.1416)$ .

Number of revolutions = Constant  $\times$  speed in feet.

Speed in feet = Number of revolutions  $\div$  constant.

Size Drill, In.	Constant.	Size Drill, In.	Constant.	Size Drill, In.	Constant.	Size Drill, In.	Constant.	Size Drill, In.	Constant.
1/8	30.55	3/4	5.09	1 3/8	2.78	2	1.91	2 5/8	1.45
3/16	20.38	13/16	4.70	1 7/16	2.66	2 1/16	1.85	2 11/16	1.42
1/4	15.28	7/8	4.36	1 1/2	2.55	2 1/8	1.80	2 3/4	1.39
5/16	12.22	15/16	4.07	1 9/16	2.44	2 3/16	1.75	2 13/16	1.36
3/8	10.19	1	3.82	1 5/8	2.35	2 1/4	1.70	2 7/8	1.33
7/16	8.73	1 1/16	3.59	1 11/16	2.26	2 5/16	1.65	2 15/16	1.30
1/2	7.64	1 1/8	3.39	1 3/4	2.18	2 3/8	1.61	3	1.27
9/16	6.79	1 3/16	3.22	1 13/16	2.11	2 7/16	1.57	3 1/16	1.25
5/8	6.11	1	3.06	1 7/8	2.04	2 1/2	1.53	3 1/8	1.22
11/16	5.56	1 5/16	2.91	1 15/16	1.97	2 9/16	1.49	3 1/4	1.18

The Cleveland Twist Drill Co., Cleveland, states (1915) that it is safe to start carbon steel drills with a peripheral speed of 30 ft. per minute in soft tool and machinery steel, 35 ft. per min. in cast iron, and 60 ft. per min. in brass. In all cases a feed of from 0.004 to 0.007 in. per revolution should be used for drills 1/2 in. diam. and smaller, and of from 0.005 to 0.015 in. per revolution for drills larger than 1/2 in. In the case of high speed steel drills these feeds should not be changed, but the peripheral speed may be increased from 2 to 2 1/2 times. The table below is calculated on the basis of the speeds given above for carbon steel drills, and on the basis of speeds 2 1/3 times higher for high-speed drills. The running speed may be higher or lower than the starting speed, and must be determined by good individual judgment for each case.

**Starting Speeds for Carbon and High-Speed Steel Drills in Steel, Cast Iron and Brass, R. P. M.**

Drill Diam., In.	Steel.		Cast Iron.		Brass.		Drill Diam., In.	Steel.		Cast Iron.		Brass.	
	Carbon.	High Speed.	Carbon.	High Speed.	Carbon.	High Speed.		Carbon.	High Speed.	Carbon.	High Speed.	Carbon.	High Speed.
1/16	1833	4278	2139	4991	3667	....	1 1/8	102	238	119	278	204	475
1/8	917	2139	1070	2496	1833	4278	1 1/4	92	214	107	249	183	428
3/16	611	1426	713	1664	1222	2852	1 3/8	83	194	97	227	167	389
1/4	458	1070	535	1248	917	2139	1 1/2	76	178	89	208	153	357
5/16	367	856	428	998	733	1711	1 5/8	70	165	82	192	141	329
3/8	306	713	357	832	611	1426	1 3/4	65	153	76	178	131	306
7/16	262	611	306	714	524	1222	1 7/8	61	143	71	166	122	285
1/2	229	535	263	614	458	1070	2	57	134	67	156	115	267
5/8	183	428	215	500	367	856	2 1/4	51	119	60	139	102	238
3/4	153	357	178	415	306	713	2 1/2	46	107	54	125	92	214
7/8	131	306	153	357	262	611	2 3/4	42	97	49	114	83	194
1	115	267	134	312	229	535	3	38	89	45	104	76	178

A drill with a tendency to wear away on the outside is running too fast; if it breaks or chips on the cutting edges it has too much feed.

**Forms of Drills.**—The common form of twist drill is a cylinder with two spiral flutes milled in it. Another type, for heavy duty, consists of a twisted bar of flat steel. The angle that the cutting edges makes with the axis of the drill has been fixed at about 59°. A decrease in this angle decreases the pressure required for feeding the drill, but increases the power required to turn it. The cutting edge of a spotting



drill should make an angle of about 50° with the axis of the drill. The clearance angle, that is, the angle between the surface back of the cutting edge and a plane perpendicular to the axis of the drill, ranges from 12 to 15°, the angle increasing slightly toward the center. In general, the small clearance is best for hard metals and the large clearance for soft metals.

**Drilling Compounds.**—The following drilling compounds or lubricants are recommended when drilling the materials given below:

Steel (hard)—kerosene, turpentine, soda water.	Iron (malleable)—soda water.
Steel (soft)—soda water, lard oil.	Iron (cast)—none or air blast.
Iron (wrought)—soda water, lard oil.	Brass—paraffine oil.
	Aluminum—soda water, kerosene.

Warming the lubricant before applying it to high-speed drills is recommended, and precautions should be taken against suddenly chilling high-speed drills by the lubricant after they have become heated.

**Twist Drill and Steel Wire Gages.**—Three standards of gages for twist drills and steel wire are in use—the Manufacturers' Standard, used by the Morse Twist Drill Co., Brown & Sharpe, and other manufacturers, the Stubs gage, and that of the Standard Tool Co. The Stubs and Manufacturers' gages are given in the table on page 30. The Standard Tool Co. gage agrees with the Manufacturers' gage for sizes from Nos. 1 to 60, inclusive, and with the Stubs gage for sizes from Nos. 61 to 80. In addition it has additional ½ sizes interpolated at Nos. 60½, 68½, 69½, 71½, 73½, 74½, 78½, and 79½.

**Power Required to Drive High-Speed Drills.**—H. M. Norris, mechanical engineer of the Cincinnati-Bickford Tool Co., found (1914) that the power absorbed by a 6-foot, high-speed, high-power, plain radial drill fitted with a variable speed motor, in driving drills in machine steel under a stream of water, varied in accordance with the formula:

$$\text{H.P.} = 0.152 (R + 2.1) d^{1.25} f^{0.74} \left[ r - \left( \frac{52.2}{d} + 6.8 \right) \right]$$

$R$  = ratio between speed of the intake shaft and speed of the spindle;  
 $d$  = diameter of drill, in.;  $f$  = feed in thousandths of an inch per revolution;  
 $r$  = rev. per min.

The values deduced from this formula are given in the table, p. 1287; the figures 1, 2, and 4 in the column "Ratio  $R$ " represent the ratios of 1 to 1, 1 to 2, and 1 to 4 respectively. The table also gives the results obtained in drilling medium cast-iron, but these, at this writing, have not been reduced to a formula.

The American Tool Works Co., Cincinnati, has furnished the author with the tests given in the table below, made in 1912, showing the power required to drive drills in a 6-foot plain triple-gear radial drill made by that company. This table shows the results obtained with speeds and feeds higher than those given by Mr. Norris.

**Power Required to Drive Drills.** (Amer. Tool Works Co., 1912.)

Size of Drill, In.	Cast Iron.					Steel.				
	Speed.		Feed.		Horse-power	Speed.		Feed.		Horse-power.
	Rev. per Min.	Ft. per Min.	Per Rev., In.	In. per Min.		Rev. per Min.	Ft. per Min.	Per Rev., In.	In. per Min.	
1	430	111.25	0.049	21.07	8.26	335	88	0.036	12.06	13.50
1¼	430	140	.049	21.07	11.65	258	84.5	.026	6.70	10.43
1½	430	157	.049	21.07	18.65	229	90	.018	4.12	14.86
1¾	430	197	.049	21.07	19.75	178	81.5	.018	3.20	9.91
2	297	156	.049	14.56	19.79	143	75	.018	2.57	12.32
2¼	202	119	.036	7.27	14.82	143	84.2	.018	2.57	15.06
2½	178	116.5	.036	6.40	11.24	143	93.6	.013	1.86	13.51
3	143	112	.036	5.14	14.31	47.5	37.2	.026	1.21	12.46

Power Required for Drilling Cast Iron and Steel. (H. M. Norris, 1915.)

Drill, Diam., in.	Cutting Speed, ft. per min.	Rev. per min.	Ratio R.	Cast Iron.						Machinery Steel.					
				0.020 in. Feed.		0.030 in. Feed.		0.040 in. Feed.		0.012 in. Feed.		0.016 in. Feed.		0.020 in. Feed.	
				Depth per min., in.	Horse-power.	Depth per min., in.	Horse-power.	Depth per min., in.	Horse-power.	Depth per min., in.	Horse-power.	Depth per min., in.	Horse-power.	Depth per min., in.	Horse-power.
3/4	60	306	1	6.12	2.76	9.18	3.52	12.24	4.20	3.67	2.84	4.90	3.53	6.12	4.15
3/4	70	357	1	7.14	3.36	10.71	4.29	14.28	5.10	4.28	3.49	5.72	4.32	7.14	5.09
3/4	80	408	1	8.16	3.98	12.24	5.08	16.32	6.04	4.90	4.12	6.53	5.10	8.16	6.02
3/4	90	459	1	9.18	4.60	13.77	5.86	18.35	6.96	5.51	4.76	7.34	5.89	9.18	6.95
3/4	100	509	1	10.18	5.21	15.27	6.64	20.36	7.89	6.11	5.40	8.14	6.68	10.18	7.88
1	60	229	2	4.58	2.88	6.87	3.67	9.16	4.36	2.75	4.01	3.66	4.96	4.58	5.85
1	70	267	1	5.34	3.09	8.00	3.94	10.67	4.68	3.21	3.72	4.27	4.60	5.34	5.43
1	80	306	1	6.12	3.66	9.18	4.66	12.24	5.54	3.67	4.39	4.89	5.44	6.12	6.42
1	90	344	1	6.88	4.22	10.32	5.38	13.76	6.39	4.13	5.16	5.50	6.39	6.88	7.54
1	100	382	1	7.64	4.79	11.46	6.11	15.27	7.26	4.59	5.79	6.11	7.17	7.64	8.46
1 1/4	60	183	2	3.66	3.10	5.49	3.95	7.32	4.70	2.19	4.21	2.93	5.21	3.66	6.15
1 1/4	70	214	2	4.28	3.80	6.42	4.84	8.56	5.75	2.57	5.17	3.42	6.40	4.28	7.55
1 1/4	80	245	2	4.90	4.50	7.36	5.74	9.80	6.82	2.94	5.96	3.92	7.57	4.90	8.93
1 1/4	90	275	1	5.48	3.95	8.22	5.04	11.00	5.99	3.29	5.35	4.38	6.62	5.48	7.81
1 1/4	100	306	1	6.12	4.49	9.18	5.73	12.24	6.81	3.67	6.08	4.89	7.52	6.12	8.87
1 1/2	60	153	2	3.12	3.27	4.59	4.17	6.12	4.96	1.84	4.36	2.45	5.39	3.12	6.36
1 1/2	70	178	2	3.56	4.02	5.34	5.12	7.02	6.08	2.14	5.35	2.85	6.62	3.56	7.81
1 1/2	80	204	2	4.08	4.77	6.06	6.08	8.16	7.23	2.45	6.35	3.26	7.86	4.08	9.27
1 1/2	90	230	2	4.60	5.51	6.90	7.03	9.20	8.36	2.76	7.35	3.68	9.10	4.60	10.73
1 1/2	100	254	2	5.04	6.27	7.62	7.99	10.16	9.50	3.05	8.34	4.07	10.32	5.04	12.17
1 3/4	60	131	2	2.62	3.42	3.93	4.36	5.24	5.18	1.57	4.48	2.10	5.55	2.62	6.55
1 3/4	70	153	2	3.06	4.21	4.59	5.37	6.12	6.38	1.84	5.53	2.45	6.84	3.06	8.07
1 3/4	80	175	2	3.50	5.00	5.25	6.38	7.00	7.58	2.10	6.56	2.80	8.12	3.50	9.58
1 3/4	90	196	2	2.92	5.80	5.88	7.39	7.84	8.78	2.35	7.60	2.14	9.41	3.92	11.10
1 3/4	100	218	2	4.36	6.59	6.52	8.40	9.12	9.98	2.62	8.63	3.49	10.68	4.36	12.60
2	60	115	4	2.30	4.87	3.45	6.22	4.60	7.39	1.38	6.82	1.84	8.44	2.30	9.96
2	70	134	2	2.68	4.38	4.04	5.59	5.36	6.64	1.61	5.66	2.14	7.00	2.68	8.26
2	80	153	2	3.06	5.21	4.59	6.65	6.12	7.90	1.84	6.73	2.45	8.33	3.06	9.83
2	90	172	2	3.44	6.04	5.16	7.71	6.88	9.16	2.06	7.81	2.75	9.66	3.44	11.40
2	100	191	2	3.82	6.87	5.73	8.77	7.64	10.32	2.29	8.87	3.06	10.98	3.82	12.95
2 1/4	60	102	4	2.04	5.18	3.06	6.60	4.08	7.84	1.22	6.95	1.63	8.60	2.04	10.14
2 1/4	70	119	4	2.38	6.40	3.57	8.16	4.76	9.70	1.43	8.60	1.90	10.64	2.38	12.55
2 1/4	80	136	2	2.68	5.40	4.08	6.88	5.44	8.18	1.63	6.88	2.18	8.52	2.68	10.05
2 1/4	90	153	2	3.06	6.27	4.59	7.99	6.12	9.50	1.84	7.98	2.45	9.88	3.06	11.65
2 1/4	100	170	2	3.40	7.13	5.10	9.09	6.80	10.80	2.04	9.09	2.72	11.25	3.40	13.27
2 1/2	60	92	4	1.83	5.46	2.75	6.96	3.67	8.27	1.10	7.06	1.47	8.74	1.83	10.31
2 1/2	70	107	4	2.14	6.76	3.21	8.63	4.28	10.26	1.28	8.75	1.71	10.83	2.14	12.77
2 1/2	80	122	4	2.44	8.06	3.66	10.29	4.88	12.23	1.46	10.43	1.95	12.91	2.44	15.23
2 1/2	90	138	2	2.76	6.46	4.14	8.24	5.52	9.79	1.66	8.14	2.21	10.08	2.76	11.89
2 1/2	100	153	2	3.06	7.36	4.59	9.39	6.12	11.16	1.84	9.28	2.45	11.49	3.06	13.55
2 3/4	60	83	4	1.67	5.73	2.50	7.30	3.34	8.68	1.00	7.15	1.33	8.85	1.67	10.44
2 3/4	70	97	4	1.94	7.11	2.92	9.06	3.89	10.77	1.17	8.87	1.55	10.98	1.94	12.95
2 3/4	80	111	4	2.22	8.49	3.33	10.83	4.44	12.87	1.33	10.62	1.78	13.14	2.22	15.50
2 3/4	90	125	4	2.50	9.90	3.75	12.62	5.00	15.00	1.50	12.34	2.00	15.27	2.50	18.00
2 3/4	100	139	2	2.78	7.59	4.17	9.68	5.56	11.50	1.67	9.46	2.23	11.71	2.78	13.81
3	60	76	4	1.53	5.96	2.29	7.60	3.06	9.03	0.92	7.22	1.22	8.94	1.53	10.55
3	70	89	4	1.78	7.42	2.67	9.46	3.56	11.25	1.07	8.98	1.43	11.12	1.78	13.12
3	80	102	4	2.04	8.88	3.06	11.32	4.08	13.45	1.27	10.75	1.63	13.31	2.04	15.71
3	90	115	4	2.30	10.33	3.45	13.17	4.60	15.65	1.38	12.52	1.84	15.48	2.30	18.26
3	100	127	4	2.54	11.75	3.81	15.00	5.08	17.82	1.52	14.26	2.03	17.65	2.54	20.82

**Feeds for Drills.**—According to Mr. Norris, the rate at which a drill may be advanced per revolution depends upon the toughness of the material to be drilled, the ability of the machine to resist thrust without forfeiture of alignment and upon the knowledge that is exercised in the grinding of the drill—the size of its included angle, the width of its chisel point, and the keenness and evenness of its cutting edges, all being deciding factors. Were it not for the weakening effect on the drill it could be said that the stiffer the machine, the less the included angle; the narrower the chisel point, the smaller the degree of the spiral; the greater the uniformity of the cutting lips and the more efficacious the lubricant in minimizing the frictional resistance of the chips, the coarser becomes the feed it is permissible to use. But, inasmuch as the durability of the drill must not be impaired, the advantage obtainable through the application of these axioms has its limitations. The keenness of edges needed to attain maximum efficiency in cutting cast-iron disqualifies for work in steel a drill suitable for use in cast-iron. The highest rate of feed at which drills of from  $\frac{3}{8}$  to 3 in. diam. may be operated in steel appears to be about 0.060 in. per revolution, but the employment of such feeds increases, rather than decreases the cost of work. The feeds provided in the product of the Cincinnati-Bickford Tool Co. range from 0.006 in. to 0.040 in. per revolution, which, under favorable conditions, may be utilized as follows:

STEEL		CAST IRON	
Hard.....	0.006 to 0.010 in.	Hard.....	0.015 to 0.020 in.
Medium.....	0.012 to 0.018 in.	Medium.....	0.020 to 0.030 in.
Soft.....	0.020 to 0.028 in.	Soft.....	0.030 to 0.040 in.

**Speed of Drills.**—Mr. Norris says further that while an occasional drill is found that will withstand for days a cutting speed of 150 ft. per minute, in either cast-iron or steel (the latter under a lubricant), it is rarely expedient to drive any but very small ones faster than 100 ft. per min. Operating drills at an excessive speed is an expensive fad. It is more economical to err in the other direction. The most satisfactory results have been obtained at a cutting speed of 80 ft. per min.

in cast-iron and  $\frac{12}{d} + 76$  ft. in steel. This formula will decrease the cutting speed from 100 ft. per min. for a  $\frac{1}{2}$ -in. drill to 80 ft. for a 3-in. drill. The reason for this reduction is that a stream of liquid sufficient to keep a small drill cool is insufficient to prevent overheating in a large one.

In order to facilitate the use of the formulæ for horse-power there is given in the following table the deduced values for  $f^{0.74}$ ,  $d^{1.25}$ ,  $\frac{52.2}{d} + 6.8$  and  $\frac{12}{d} + 76$ .

Values of  $f^{0.74}$ ,  $d^{1.25}$ ,  $\frac{52.2}{d} + 6.8$  and of  $\frac{12}{d} + 76$ .

Feed, In.	$f^{0.74}$	Diameter, Inch.	$d^{1.25}$	$\frac{52.2}{d} + 6.8$	$\frac{12}{d} + 76$	Feed, In.	$f^{0.74}$	Diameter, Inch.	$d^{1.25}$	$\frac{52.2}{d} + 6.8$	$\frac{12}{d} + 76$
0.008	0.02807	$\frac{1}{2}$	0.421	111.2	100.0	0.022	0.05934	$\frac{17}{8}$	2.194	34.6	82.4
.009	.03063	$\frac{5}{8}$	.556	90.3	95.2	.024	.06329	2	2.378	32.9	82.0
.010	.03312	$\frac{3}{4}$	.698	76.4	92.0	.026	.06715	$\frac{21}{8}$	2.566	31.4	81.6
.011	.03553	$\frac{7}{8}$	.846	66.6	89.7	.028	.07094	$\frac{21}{4}$	2.756	30.0	81.3
.012	.03789	1	1.000	59.0	88.0	.030	.07466	$\frac{23}{8}$	2.948	28.8	81.0
.013	.04021	$\frac{11}{8}$	1.158	53.2	86.9	.032	.07831	$\frac{21}{2}$	3.144	27.7	80.0
.014	.04248	$\frac{11}{4}$	1.322	48.5	85.6	.034	.08190	$\frac{25}{8}$	3.342	26.7	80.6
.015	.04470	$\frac{13}{8}$	1.489	44.8	84.7	.036	.08544	$\frac{23}{4}$	3.541	25.8	80.4
.016	.04689	$\frac{11}{2}$	1.660	41.6	84.0	.038	.08894	$\frac{27}{8}$	3.741	25.0	80.2
.018	.05115	$\frac{15}{8}$	1.833	38.9	83.4	.040	.09237	3	3.948	24.2	80.0
.020	.05530	$\frac{13}{4}$	2.013	36.6	82.9						



**Extreme Results with Drills.**—The Cleveland Twist Drill Co. furnishes the following table of results of drilling tests made at the convention of Railway Master Mechanics' Association at Atlantic City, N. J., June, 1911. The object of the tests was to demonstrate good shop practice, drilling being done at speeds and feeds considered economical under average shop conditions, and also to show what were the ultimate possibilities of drills and machines. The drills used were flat twisted drills, and the ordinary milled drill. The record performance for high-speed drilling is test No. 4, in which a 1 1/4 in. drill repeatedly drilled through a casting at 57 1/2 in. per minute. In the tests to demonstrate good shop conditions, the drill in test No. 17 drilled 68 holes, removing 1418 cu. in. of metal without being reground, and was in good condition at the close of the test. The Cleveland Twist Drill Co. does not recommend the high speeds and heavy feeds attained as economical shop practice, but points out that the results can be duplicated by carefully established ideal conditions of absolute rigidity in the machine, solid clamping of the work, perfect grinding of the drill and expert handling.

### Record Performances of High-Speed Drills.

No.	Sizes of Drill, In.	Material	R.P.M.	Feed per Rev.	Inches Drilled per Min.	Rev., Speed in Feet per Min.	Cu. In. Metal Removed per Min.
1	1 1/4	Cast Iron 3 1/2" thick	500	0.050	25	163.6	30.68
2	1 1/4		325	0.100	32 1/2	106	39.88
3	1 1/4		475	0.100	47 1/2	155	58.29
4	1 1/4		575	0.100	57 1/2	188	70.56
5	1 1/2		300	0.030	9	117	15.90
6	1 1/2		325	0.100	32 1/2	127.6	57.43
7	1 1/2		335	0.100	33 1/2	131.5	59.19
8	1 1/2		355	0.100	35 1/2	139.4	62.73
9	1 3/4		235	0.100	23 1/2	107.6	56.52
10	1 3/4		350	0.100	35	160	84.19
11	2 5/16		190	0.050	9 1/2	115	39.90
12	3		120	0.100	12	94	84.82
13	1 1/4	Machinery Steel 4 1/4" thick	350	0.030	10 1/2	113.7	12.88
14	1 5/8		225	0.040	9	94.8	18.66
15	2 5/16		165	0.020	3 1/4	100	13.86
16	2 5/16		200	0.020	4	121	16.80
17	2 1/2*		150	0.015	2 1/4	98	11.04
18	2 1/2*		150	0.040	6	98	29.45
19	2 1/2*		175	0.040	7	114.5	34.36
20	1 3/4		275	0.030	8 1/4	125	19.84
21	3		150	0.030	4 1/2	117.8	31.81
22	3 1/4		150	0.030	4 1/2	127	37.33

\* Milled drills; all other drills are flat twisted drills.

**Experiments on Twist Drills.**—An extensive series of experiments on the forces acting on twist drills of high-speed steel when operating on cast-iron and steel is reported by Dempster Smith and A. Poliakoff, in *Proc. Inst. M. E.*, 1909. Abstracted in *Am. Mach.*, May, 1909, and *Indust. Eng.*, May, 1909. Approximate equations derived from the first set of experiments are as follows:

Torque in pounds-feet,  $I = (1800t + 9)d^2$ , for medium cast-iron;  $T = (3200t + 20)d^2$ , for medium steel. End thrust, lb.,  $P = 115,000t - 200$ , for medium cast-iron;  $P = 160,000(d - 0.5)t - 1000$ , for medium steel;  $d = \text{diam.}$ ,  $t = \text{feed per revolution of drill}$ , both in inches. The steel was of medium hardness, 0.29 C, 0.625 Mn.

The end thrust in enlarging holes in medium steel from one size to a larger was as follows: 3/4 in. to 1 in.,  $P = 15,200t + 60$ ; 1 in. to 1 1/2 in.,  $P = 25,500t + 3$ ; 3/4 in. to 1 1/2 in.,  $P = 30,000t + 200$ .

A second series of experiments with soft cast-iron of C.C., 0.2; G.C., 2.9; Si, 1.41; Mn, 0.68; S, 0.035; P, 1.48, and medium steel of C, 0.31;

Si, 0.07; Mn, 0.50; S, 0.018; P, 0.033; tensile strength, 72,600 lb. per sq. in., gave results from which were derived the following approximate equations:

Torque, lb.-ft.,  $T = 740 d^{1.8} t^{0.7}$ , or  $10 d^2 + 100 t(14 d^2 + 3)$  for cast iron,  
 $T = 1640 d^{1.8} t^{0.7}$ , or  $28 d^2(1 + 100 t)$  for medium steel,  
 End thrust, lb.  $P = 35,500 d^{0.7} t^{0.75}$ , or  $200 d + 10,000 t$  for cast iron,  
 $P = 35,500 d^{0.7} t^{0.3}$ , or  $750 d + 1000 t(75 d + 50)$  for  
 medium steel,

and for different sizes of drill the following equations:

Drill.	$\frac{3}{4}$	1	$1\frac{1}{2}$
Cast iron $T = \dots\dots\dots$	$5 + 1,100 t$	$10 + 1,750 t$	$25 + 3,700 t$
Cast iron $P = \dots\dots\dots$	$125 + 82,000 t$	$200 + 89,000 t$	$350 + 103,000 t$
Steel $T = \dots\dots\dots$	$7.5 + 3,350 t$	$17.5 + 4,400 t$	$40 + 9,000 t$
Steel $P = \dots\dots\dots$	$550 + 109,000 t$	$750 + 131,000 t$	$1,250 + 162,000 t$

Drill.	2	$2\frac{1}{2}$	3
Cast iron $T = \dots\dots\dots$	$40 + 5,900 t$	$60 + 8,800 t$	$90 + 12,900 t$
Cast iron $P = \dots\dots\dots$	$500 + 110,000 t$	$600 + 126,000 t$	$850 + 140,000 t$
Steel $T = \dots\dots\dots$	$75 + 12,500 t$	$112.5 + 19,050 t$	$175 + 26,250 t$
Steel $P = \dots\dots\dots$	$1,500 + 181,250 t$	$1,725 + 224,375 t$	$2,350 + 280,000 t$

The tests above referred to were made without lubricants. When lubricants were used in drilling steel the average torque varied from 72% with 1/400 in. feed to 92% with 1/35 in. feed of that obtained when operating dry. The thrust for soft, medium and hard steel is 26%, 37%, and 12% respectively less than when operating dry, no marked difference being found, as in the torque, with different feeds. The horse-power varies as  $t^{0.7}$  and as  $d^{0.8}$  for a given drill and speed. The torque and horse-power when drilling medium steel is about 2.1 times that required for cast iron with the same drill speed and feed. The horse-power per cu. in. of metal removed is inversely proportional to  $d^{0.2} t^{0.3}$ , and is independent of the revolutions.

While the chisel point of the drill scarcely affects the torque it is accountable for about 20% of the thrust. Tests made with a preliminary hole drilled before the main drill was used to enlarge the hole showed that the work required to drill a hole where only one drill is used is greater than that required to drill the hole in two operations, with drills of different diameter.

For economy of power a drill with a larger point angle than  $120^\circ$  is to be preferred, but the increased end thrust strains the machine in proportion, and there is more danger of breaking the drill.

**Cutting Speeds for Tapping and Threading.** (*Am. Mach.*, Aug. 3, 1911.)—The National Machine Co., for tapping and threading, uses speeds of 233 r.p.m. for sizes and holes up to 1/4 in. diameter, and 140 r.p.m. for sizes from 1/4 in. to 1/2 in. diameter, with a lubricant of screw-cutting oil. Both the Bignall & Keeler Co. and the Standard Engineering Co. recommend a cutting speed of 15 ft. per minute. The former recommends lard oil as a lubricant. The practice of the F. E. Wells Co. in tapping and the Landis Machine Co. in threading in machines of the bolt cutter type is as follows:

#### Speeds for Tapping and Threading—r. p. m.

Mate- rial.	F. E. Wells.		Landis.		Mate- rial.	F. E. Wells.		Landis.	
	Steel.	Cast Iron.	Steel.	Cast Iron.		Steel.	Cast Iron.	Steel.	Cast Iron.
Lubri- cant.	Oil.	Oil or Soda Comp.	Oil.	Petro- leum.	Lubri- cant.	Oil.	Oil or Soda Comp.	Oil.	Petro- leum.
$\frac{1}{4}$ in.	299	382	280	200	$\frac{3}{4}$ in.	76	127	140	100
$\frac{3}{8}$ "	153	255	220	150	1	.....	.....	115	85
$\frac{1}{2}$ "	115	191	175	125	$1\frac{1}{2}$ "	.....	.....	75	55
$\frac{5}{8}$ "	91	153	.....	.....	2	.....	.....	6	45

## SAWING METALS.

**Speeds and Feeds for Cold Sawing Metals.**—(*Mach'y*, Jan., 1914).—For sawing 0.30 carbon, open-hearth machine steel bars in a cold sawing machine, a feed of 1 in. per minute and a peripheral speed of approximately 45 ft. per minute was used. The bars were 5 in. diameter, and an average of 145 were sawed with one sharpening of the saw. For some classes of work a feed of 2 in. per minute can be used, but  $\frac{3}{4}$  in. per minute is advisable for 0.30 carbon steel with the saw in good condition. For tool steel and alloy steel the best economy will be obtained with a feed of  $\frac{1}{2}$  in. per minute and a surface speed of 30 ft. per minute, with a grinding every 100 pieces.

**Hack Sawing Machines.**—Charles Wicksteed (*Proc. Inst. Mech. Engrs.*, 1912) says that the important considerations to be observed in using hack sawing machines are: For ordinary work, a coarse pitch tooth, not less than 10 to the inch is best; extra strength of the saw is to be obtained by extra depth, not extra thickness, of blade; the greatest weight that a blade will take without injury is 7 lb. per tooth or 70 lb. per in.; a 6-in. machine thus will use the full capacity of the blade on 4-in. bars with a weight of 210 lb. on the blade. As the size of the machine increases, the weight increases proportionately, a 15-in. machine employing 700 lb. and using the full capacity of the blade when sawing a 10-in. surface. A hack sawing machine will cut true to 0.01 in. in a mild steel bar at a speed roughly of 1 to 2 sq. in. per minute.

**Saws for Copper.**—A special saw for cutting copper has teeth with a front rake of  $10^\circ$ . The metal is ground away at the sides of the teeth to provide clearance. The number of teeth should be comparatively small. A pitch of about 1 in. giving 10 teeth in 3-in. saw renders good service.

## CASE-HARDENING, ETC.

**Case-hardening of Iron and Steel, Cementation, Harveyizing.**—When iron or soft steel is heated to redness or above in contact with charcoal or other carbonaceous material, the carbon gradually penetrates the metal, converting it into high carbon steel. The depth of penetration and the percentage of carbon absorbed increase with the temperature and with the length of time allowed for the process. In the old cementation process for converting wrought iron into "blister steel" for re-melting in crucibles flat bars were packed with charcoal in an oven which was kept at a red heat for several days. In the Harvey process of hardening the surface of armor plate, the plate is covered with charcoal and heated in a furnace, and then rapidly cooled by a spray of water.

In case-hardening, a very hard surface is given to articles of iron or soft steel by covering them or packing them in a box or oven with a material containing carbon, heating them to redness while so covered, and then chilling them. Many different substances have been used for the purpose, such as wood or bone charcoal, charred leather, sugar, cyanide of potassium, bichromate of potash, etc. Hydrocarbons, such as illuminating gas, gasolene or naphtha, are also used. *Amer. Machinist*, Feb. 20, 1908, describes a furnace made by the American Gas Furnace Company of Elizabeth, N. J., for case-hardening by gas. The best results are obtained with soft steel, 0.12 to 0.15 carbon, and not over 0.35 manganese, but steel of 0.20 to 0.22 carbon may be used. The carbon begins to penetrate the steel at about  $1300^\circ\text{F.}$ , and  $1700^\circ\text{F.}$  should never be exceeded with ordinary steels. A depth of carbonizing of  $\frac{1}{64}$  in. is obtained with gas in one hour, and  $\frac{1}{4}$  in. in 12 hours. After carbonizing the steel should be annealed at about  $1625^\circ\text{F.}$  and cooled slowly, then re-heated to about  $1400^\circ\text{F.}$  and quenched in water. Nickel-chrome steels may be carbonized at  $2000^\circ\text{F.}$  and tungsten steels at  $2200^\circ\text{F.}$

**Change of Shape due to Hardening and Tempering.**—J. E. Storey, *Am. Mach.*, Feb. 20, 1908, describes some experiments on the change of dimensions of steel bars 4 in. long,  $\frac{7}{8}$  in. diam. in hardening and tempering. On hardening the length increased in different pieces .0001 to .0014 in., but in two pieces a slight shrinkage, maximum .00017, was found. The diameters increased .0003 to .0036 in. On tempering the length decreased .0017 to .0108 in. as compared with the original 4 ins. length, while the diameter was increased .0003 to .0029; a few samples showing a decrease, max. .0009 in. The general effect of hardening is a slight increase in bulk, which increase is reduced by tempering.



### POWER REQUIRED FOR MACHINE TOOLS.

**Resistance Overcome in Cutting Metal.** (*Trans. S. M. E.*, viii, 308.)—Some experiments made at the works of William Sellers & Co. showed that the resistance in cutting steel in a lathe would vary from 180,000 to 700,000 pounds per square inch of section removed, while for cast iron the resistance is about one-third as much. The power required to remove a given amount of metal depends on the shape of the cut and on the shape and sharpness of the tool used. If the cut is nearly square in section, the power required is a minimum; if wide and thin, a maximum. The dullness of a tool affects but little the power required for a heavy cut.

F. W. Taylor, in the *Art of Cutting Metals* (*Trans. A. S. M. E.*, xviii) gives the tangential pressure of the chip on the tool as ranging from 70,000 lb. per sq. in. when cutting soft cast iron with a coarse feed, to 198,000 lb. per sq. in. when cutting hard cast iron with a fine feed. In cutting steel, the pressure of the chip on the tool per sq. in. ranged from 184,000 lb. to 376,000 lb. The pressure, he found, is independent of the speed, and in the case of steel is independent of the hardness of the steel. It increases as the quality of the steel grows finer; that is, high grade steel, whether hard or soft, will give higher pressures than low grade steel. He also found that an increase in the tensile strength and ductility of the steel increases the pressure, the former having the greater effect.

**Horse-power Required to Run Lathes.**—The power required to do useful work varies with the depth and breadth of chip, with the shape of tool and with the nature and density of metal operated upon; and the power required to run a machine empty is often a variable quantity. For instance, when the machine is new, and the working parts have not become worn or fitted to each other as they will be after running a few months, the power required will be greater than will be the case after the running parts have become better fitted.

Another cause of variation of the power absorbed is the driving-belt; a tight belt will increase the friction.

A third cause is the variation of journal-friction, due to slacking up or tightening the cap-screws, and also the end-thrust bearing screw.

Owing to the demand imposed by high speed tool steels stouter machines are more necessary than formerly; these possess more rigid frames and powerful driving gears. The most modern (1915) forms of lathes obtain all speed changes by means of geared head-stocks, power being delivered at a single speed by a belt, or by a motor. If a motor drive is used, a speed variation may be obtained in addition to those available in the head, by using a variable speed motor, whose range usually is about 3:1. The tables on p. 1293 show the results of tests made by the Lodge & Shipley Co. in 1906 to determine the power required to remove metal in a 20-in. lathe with a cone pulley drive, and also in a similar lathe with a geared head.

**Power Required to Drive Machine Tools.**—The power required to drive a machine tool varies with the material to be cut. There is considerable lack of agreement among authorities on the power required. Prof. C. H. Benjamin (*Mach'y*, Sept., 1902) gives a formula  $H.P. = cW$ ,  $c$  being a constant and  $W$  the pounds of metal removed per hour.  $c$  varies both with the quality of metal and the type of machine.

Values of  $c$ .

	Lathe.	Planer.	Shaper.	Milling Machine.
Cast iron . . . . .	0.035	0.032	0.030	0.14
Machinery steel . . . . .	0.067	.....	.....	.....
Tool steel . . . . .	.....	.....	.....	0.30
Bronze . . . . .	.....	.....	.....	0.10

In each case the power to drive the machine without load should be added. G. M. Campbell (*Proc. Engr. Soc. W., Pa.*, 1906) gives, exclusive of friction losses,  $H.P. = Kw$ ,  $K$  being a constant and  $w$  the pounds of metal removed per minute. For hard steel  $K = 2.5$ ; for soft

**Horse-power Required to Remove Metal in Lathes.**

(Lodge & Shipley Mach. Tool Co., 1906.)

**20-INCH CONE-HEAD LATHE.**

Material Cut.	Cutting Speed, ft. per min.	Cut, In.		Diam. of work, in.	Cu. in. removed per min.	Lb. removed per hour.	H.P. used by Lathe.		Cu. in. removed per H.P.
		Depth.	Feed.				Idle.	With Cut.	
Crucible Steel 0.60 Carbon	35	0.109	1/8	227/32	5.74	96	0.48	3.90	1.471
	65	0.055	1/8	3 5/8	5.33	90	0.74	4.60	1.158
	62.5	0.109	1/16	3 5/16	5.125	86	0.49	4.65	1.102
	32.5	0.094	1/10	3 5/16	3.656	62	0.49	2.64	1.384
Cast Iron	62.5	0.273	1/12	3 5/32	17.09	266	0.66	5.44	3.141
	60	0.430	1/19	2 21/64	16.27	253	0.59	4.77	3.410
	37.5	0.334	1/16	2 21/32	10.76	167	0.45	3.91	2.751
	115	0.086	1/12	1 55/64	9.88	153	0.21	2.54	3.889
Open-hearth Steel 0.30 Carbon	50	0.109	1/8	2 23/32	8.2	138	0.69	5.34	1.535
	45	0.117	1/8	2 1/2	7.91	134	0.53	5.11	1.547
	45	0.217	1/19	2 17/64	6.439	109	0.69	4.10	1.570
	32.5	0.109	1/8	2 23/64	5.33	90	0.36	4.04	1.319

Average H.P. running idle 0.53; average H.P. with cut 4.25.

**20-INCH GEARED-HEAD LATHE,**

Material Cut.	Cutting Speed, ft. per min.	Cut, in.		Diam. of work, in.	Cu. in. removed per min.	Lb. removed per hour.	H.P. used by Lathe.		Cu. in. removed per H.P.
		Depth.	Feed.				Idle.	With Cut.	
0.50 Carbon Crucible Steel.	40	0.266	1/10	2 27/32	12.75	215	2.11	11.1	1.142
	50	0.281	1/15	2 27/32	11.25	190	1.58	8.35	1.347
	75	0.281	1/15	2 27/32	16.87	285	1.58	12.69	1.329
	85	0.109	1/15	2 1/4	7.43	126	1.28	8.98	0.827
Cast Iron	45	0.609	1/16	7 21/32	20.57	320	1.34	6.94	2.963
	62.5	0.609	1/16	7 21/32	28.56	445	1.35	9.50	3.006
	85	0.641	1/16	7 21/32	40.82	636	1.64	12.69	3.216
	80	0.281	1/8	3 3/32	33.75	526	1.18	10.49	3.217
Open-hearth Steel 0.15 Carbon	125	0.250	1/28	4 21/32	13.4	226	1.62	10.60	1.265
	105	0.188	1/12	4 5/32	19.68	332	0.94	11.56	1.702
	40	0.172	1/6	3 27/32	13.75	232	1.75	12.49	1.100
	180	0.094	1/16	3 1/16	12.65	213	2.15	11.20	1.129

Average H.P. running idle 1.543; average H.P. with cut 10.55.

steel  $K = 1.8$ ; for wrought iron,  $K = 2.0$ ; for cast iron,  $K = 1.4$ . This formula gives results about 50% lower than Prof. Benjamin's.

L. L. Pomeroy (*Gen. Elec. Rev.*, 1908) gives: H.P. required to drive =  $12 FDSNC$ , in which  $F$  = feed and  $D$  = depth of cut, in inches,  $S$  = speed in ft. per min.,  $N$  = number of tools cutting,  $C$  = a constant, whose values with ordinary carbon steel tools are: for cast iron, 0.35 to 0.5; soft steel or wrought iron, 0.45 to 0.7; locomotive driving-wheel tires, 0.7 to 1.0; very hard steel, 1.0 to 1.1. This formula is based on Prof. Flather's dynamometer tests. An analysis of experiments by Dr. Nicholson of Manchester, which confirm the formula, showed the average H.P. required at the motor per pound of metal removed per minute to be as follows: Medium or soft steel, or wrought iron, 2.4 H.P.; hard steel, 2.65 H.P.; cast iron, soft or medium, 1.00 H.P.; cast iron, hard, 1.36 H.P.

Actual tests (1906) of a number of machine tools in the shops of the Pittsburg and Lake Erie R.R. showed the horse-power absorbed in driving under the conditions given in the table on p. 1295. The results obtained are compared with those computed by Campbell's formula on p. 1292. It will be observed that the sizes of motors actually used on the various machines in the table agree quite closely with the sizes recommended in the tables, pp. 1294 to 1298.

**Sizes of Motors for Machine Tools.**—The size of motor applied to machine tools which are driven by an individual motor is usually determined by the experience of the manufacturer, rather than by any formula. The same lathe, for instance, will be fitted with a larger motor if it is required to take heavy roughing cuts continuously in tough steel, than if it is to have a more general run of lighter work in cast iron. Even if it does, under the latter conditions of service, occasionally receive a job up to the limit of its capacity, the motor will be able to stand the temporary overload, whereas a continuous overload would soon ruin it. The conditions under which the machine will operate should therefore be stated when it or the motor to drive it is purchased. The tables given on pages 1294 to 1298 show the sizes of motors for machine tools as recommended by the Westinghouse Elect. & Mfg. Co. The sizes given embody average practice. The type of motor to be used varies with the conditions of service, and the type suitable for the different classes of machinery are indicated by the following symbols:

A. Adjustable speed, shunt wound, direct current motor; used where a number of speeds are essential.

B. Constant speed, shunt wound, direct current motor; used when the desired speeds are obtainable by a cone pulley or gear box, or where only a single speed is required.

C. Squirrel cage induction motor; used where direct current is not available. A cone pulley or gear box is necessary if more than one speed is desired.

D. Constant speed, compound wound, direct-current motor, used when different speeds are obtainable by means of a cone pulley or gear box, or where but one speed is necessary.

E. Wound secondary or squirrel cage induction motor with about 10% slip; used where direct current is not available, or where one speed is required.

F. Adjustable speed, compound wound, direct current motor; used where a number of speeds are necessary.

G. Standard bending roll motor.

H. Standard machine tool traverse motor.

### Turning and Boring Machines.

#### ENGINE LATHES—Motor A, B or C.

Swing, in.....	12	14	16	18	20-22	24-27
Horse-power, average.....	1/2	3/4-1	1-2	2-3	3	5
Horse-power, heavy.....	2	2-3	2-3	3-5	7.5-10	7.5-10
Swing, in.....	30	32-36	38-42	48-54	60-84	60-84
Horse-power, average.....	5-7.5	7.5-10	10-15	15-20	20-25	20-25
Horse-power, heavy.....	7.5-10	10-15	15-20	20-25	25-30	25-30

#### WHEEL LATHES—Motor A, B or C.

Size, in.....	48	51-60	79-84	90	100
Horse-power.....	15-20	15-20	25-30	30-40	40-50
H.P. of tail stock motor (H)	5	5	5	5-7.5	5-7.5

#### AXLE LATHES—Motor A, B or C.

Single.....	5,	7.5,	10	Horse-power
Double.....	10,	15,	20	"

#### BUFFING LATHES—Motor B or C.

Number of wheels.....	2	2	2	2
Diameter of wheels, in.....	6	10	12	14
Horse-power.....	1/4-1/2	1-2	2-3	3-5

For brass tubing and other special work use about double the above H.P.



Horse-power to Drive Machine Tools.

Tool.	Material.	Cut, Inches.		Speed, Ft. per Min.	Wt. Removed, Lb. per Min.	H.P. Required.		Motor Used.
		Feed.	Depth.			Actual.	Formula.	
72-in. wheel lathe	Hard steel " " " " " "	1/12	3/16 & 1/4	13.7	1.69	4.5	4.2	25 H.P. shunt wound variable speed.
		1/8	3/16 & 1/4	11.6	2.15	6.4	5.4	
		3/16	5/16 & 3/8	13.2	5.55	8.4	13.9	
		3/16	3/8 & 3/8	13.2	6.3	12.0	15.7	
90-in. wheel lathe	Hard steel " " " "	3/16	3/16 & 3/16	13.0	3.1	12.0	7.7	25 H.P. shunt wound variable speed.
		3/16	5/16 & 5/16	8.8	3.5	8.1	8.7	
		1/5	1/4 & 1/4	15.5	5.3	9.0	13.2	
42-in. lathe	Soft steel " " " "	1/16	1/4	44	2.33	3.8	4.2	15 H.P. shunt wound variable speed.
		1/16	1/8	44	1.17	1.7	1.9	
	1/16	1/8	44	1.17	2.6	1.9		
	Cast iron " "	1/16	1/8	108	2.63	5.8	3.7	
		1/16	3/16	46	1.74	2.9	2.5	
1/16	3/16	58	2.12	2.2	3.0			
30-in. lathe	Wro't iron " "	1/8	3/16	54	4.2	6.6	8.4	10 H.P. shunt wound variable speed.
		1/8	3/16	42	3.2	4.0	6.4	
	Cast iron " "	3/32	5/32	42	1.92	3.0	2.7	
		3/32	1/16	61	1.12	1.5	1.6	
1/64	1/4	47	2.30	2.0	3.2			
Axle lathe	Soft steel " "	3/16	1/4	27	4.3	5.9	7.7	35 H.P. sh. w'd var. speed.
		1/16	1/4	51	2.7	5.0	4.9	
72-in. boring mill . .	Soft steel " " " " " "	1/8	1/16 & 1/32	44	1.76	2.9	3.2	25 H.P. shunt wound variable speed.
		3/16	1/32 & 1/16	40	2.38	2.6	4.3	
		1/8	1/8 & 1/8	51	5.41	9.6	9.7	
	Cast iron " " " "	1/8	3/16	47	3.75	7.2	6.8	
		1/16	3/8	28	2.05	2.6	2.9	
		1/16	1/4	39	1.90	2.7	2.7	
24-in. drill press .	Wro't iron " " " " " " " "	1/64	1 1/4 to 3*	25.1	0.81	2.3	1.6	
		1/64	1 1/4 to 3*	29.7	0.96	2.7	1.9	
		1/64	1 1/4 to 3*	25.9	0.83	1.3	1.7	
		1/64	1 1/4 drill	74.5	0.52	3.5	1.0	
		1/64	1 1/4 drill	20.9	0.54	1.2	1.1	
60-in. planer	Soft steel " "	1/6	1/4	25.5	3.62	5.9	6.5	20 H.P. compound wound variable speed.
		1/6	1/4	25.7	3.65	6.5	6.6	
	Wro't iron " "	3/16	5/16 & 5/16	23	8.95	21.0	17.9	
		1/2	1/32 & 1/32	17.5	1.82	2.7	3.6	
	Cast iron " " " "	1/8	1/8 & 1/16	22.2	1.72	6.5	3.4	
		1/8 & 1/16	1/4 & 5/16	30	4.74	9.3	6.6	
1/7	1/4 & 1/4	22.6	5.03	7.6	7.1			
1/4	7/16 & 3/8	28.9	18.3	23.2	25.6			
42-in. planer	Soft steel " "	5/32	3/8	24.3	4.73	12.1	9.5	15 H.P. compound wound variable speed.
		1/8	3/8	36	3.7	7.8	11.4	
	Cast iron " "	3/16	3/16	37	4.06	4.7	5.7	
		3/16	1/8	37	2.71	4.1	3.8	
19-in. slotter	Hard steel Soft steel	1/32	1/4	30.0	0.8	2.0	2.0	13 H.P. comp. w'd var. speed.
		1/32	3/8	23.3	0.93	1.3	1.7	

\* Enlarging hole from smaller dimensions to larger.

**BORING AND TURNING MILLS—Motor A, B or C.**

	In.	In.	In.	Ft.	Ft.	Ft.	Ft.
Size.....	37-42	50	60-84	7-9	10-12	14-16	16-25
H.P., average..	5-7.5	7.5	7.5-10	10-15	10-15	15-20	20-25
H.P., heavy...	7.5-10	7.5-10	10-15	.....	30-40	.....	.....

**CYLINDER BORING MACHINES—Motor A, B or C.**

Diameter of spindle, in.....	4	6	8
Maximum boring diameter, in.....	10	30	40
Horse-power.....	7.5	10	15

**HORIZONTAL BORING, DRILLING AND MILLING MACHINES—Motors A, B or C.**

Size of spindle, in.....	3.5-4.5	4.5-5.5	5.5-6.5
Horse-power per spindle...	5-7.5	7.5-10	10-15

**Drilling Machines.**

Sensitive Drills up to 1/2 in..... 1/4-3/4 H.P. Motor A, B or C.

**UPRIGHT DRILLS—Motor A, B or C.**

Size, in.....	12-20	24-28	30-32	36-40	50-60
Horse-power.....	1	2	3	5	5-7.5

**RADIAL DRILLS—Motor A, B or C.**

Length of arm, ft.....	3	4	5-7	8-10
Horse-power, average.....	1-2	2-3	3-5	5-7.5
Horse-power, heavy.....	3	5-7.5	5-7.5	7.5-10

**MULTIPLE SPINDLE DRILLS—Motor A, B or C.**

Size of drill, in.	1/32-1/4	1/16-3/8	3/16-1/2	1/4-3/4	3/8-1	2	2	2
No. of spindles, up to.....	6-10	10	10	10	10	4	6	8
Horse-power..	3	5	7.5	10	10-15	7.5	10	15

**Planing Machinery.**

**PLANERS—Motor C, D or F.**

Width, in.....	22	24	27	30	36	42
Distance under rail, in.	22	24	27	30	36	42
Horse-power.....	3	3-5	3-5	5-7.5	10-15	15-20
Width, in.....	48	54	60	72	84	100
Distance under rail, in..	48	54	60	72	84	100
Horse-power.....	15-20	20-25	20-25	25-30	30	40

**SHAPERS—Motor A, B or C.**

**Traverse Head.**

Stroke, in.....	12-16	18	20-24	30	20	24
H.P., single head.....	2	2-3	3-5	5-7.5	7.5	10

**SLOTTERS—KEYSEATERS—Motor A, B or C.**

Stroke, in.....	6	8	10	12	14
Horse-power.....	3	3-5	5	5	5-7 1/2
Stroke, in.....	16	18	20	24	30
Horse-power.....	7.5	7.5-10	10-15	10-15	10-15

**Milling Machinery.**

**PLAIN MILLING MACHINES—Motor A, B or C.**

Table feed, in.....	34	42	50
Cross feed, in.....	10	12	12
Vertical feed, in.....	20	20	21
Horse-power.....	7.5	10	15

**UNIVERSAL MILLING MACHINES—Motor A, B or C.**

Machine number.....	1	1 1/2	2	3	4	5
Horse-power.....	1-2	1-2	3-5	5-7.5	7.5-10	10-15

VERTICAL MILLING MACHINES—Motor A, B or C.

Height under Spindle, in . . . . .	12	14	18	20	24
Horse-power . . . . .	5	7.5	10	15	20

VERTICAL SLABBING MACHINES—Motor A, B or C.

Width of work, in . . . . .	24	32-36	42
Horse-power . . . . .	7.5	10	15

HORIZONTAL SLABBING MACHINES—Motor A, B or C.

Width between housings, in . . . . .	24	30	36	60	72
Horse-power, average . . . . .	7.5-10	7.5-10	10-15	25	25
Horse-power, heavy . . . . .	10-15	10-15	20-25	50-60	75

GEAR CUTTERS—Motor A, B or C.

Size, in . . . . .	36 × 9	48 × 10	30 × 12	60 × 12	72 × 14	64 × 20
Horse-power . . . . .	2-3	3-5	5-7.5	5-7.5	7.5-10	10-15

ROTARY PLANERS—Motor A, B or C.

Diam. of cutter, in . . . . .	24	30	36-42	48-54	60	72	84	96-100
Horse-power . . . . .	5	7.5	10	15	20	25	30	40

SAWS, COLD AND CUT-OFF—Motor A, B or C.

Size of saw, in . . . . .	20	26	32	36	42	48
Horse-power . . . . .	3	5	7.5	10-15	20	25

**Bolt and Nut Machinery.**

BOLT CUTTERS—Motor A, B or C.

	Single.			Double.		Triple.
Size, in . . . . .	1, 1 1/4, 1 1/2	1 3/4, 2	2 1/4, 3 1/2	4, 6	1, 1 1/2	2, 2 1/2
H.P. . . . .	1-2	2-3	3-5	5-7.5	2-3	3-5
						1, 1 1/2, 2
						3-7.5

BOLT POINTERS—Motor B or C.

Size, in . . . . .	1 1/2, 2 1/2	Horse-power . . . . .	1-2
--------------------	--------------	-----------------------	-----

NUT TAPPERS—Motor A, B or C.

	4 Spindle. 6 Spindle. 10 Spindle.		
Size, in . . . . .	1, 2	2	2
Horse-power . . . . .	3	3	5

NUT FACING MACHINE—Motor B or C.

Size, in . . . . .	1, 2	Horse-power . . . . .	2-3
--------------------	------	-----------------------	-----

BOLT HEADING, UPSETTING AND FORGING—Motor D, E or F.

Size, in . . . . .	3/4-1 1/2	1 1/2-2	2 1/2-3	4-6
Horse-power . . . . .	5-7.5	10-15	20-25	30-40

**Bending or Forming Machinery—Hammers.**

BULLDOZERS—Motor D or E.

Width, in . . . . .	29	34	39	45	63
Head movement, in . . . . .	14	16	16	18	20
Horse-power . . . . .	5	7.5	10	15	20

BENDING AND STRAIGHTENING ROLLS—Motor E or G.

Width, ft . . . . .	4	6	6	8	10	10	24
Thickness, in . . . . .	3/8	5/16	7/16	3/4	7/8	1 1/8	1 1/2
Horse-power . . . . .	5	5	7.5	15	25	35	50

HAMMERS—Motor D or E.

Size, lb . . . . .	15 to 75	100 to 200
Horse-power . . . . .	1/2 to 5	5 to 7.5

Bliss drop hammers require approximately 1 H.P. for every 100 lb. weight of hammer head.

**Pipe Threading and Cutting-off Machinery.**

Motor A, B or C.

Pipe size, in . . . . .	1/4-2	1/2-3	1-4	1 1/4-6	2-8	3-10	4-12	8-18	24
Horse-power . . . . .	2	3	3	3-5	3-5	5	5	7.5	10



**Punching and Shearing Machinery.**Presses for notching sheet-iron—Motor *A, B* or *C*— $1/2$  to 3 H.P.PUNCHES—Motor *D* or *E*.

Diameter, in. . . . .	$3/8$	$1/2$	$5/8$	$3/4$	$7/8$	1	1	$1 1/4$	$1 3/4$	2	$2 1/2$
Thickness, in. . . . .	$1/4$	$1/2$	$5/8$	$3/4$	$3/4$	$1 1/2$	1	1	1	1	$1 1/2$
Horse-power. . . . .	1	2-3	2-3	3-5	5	5	7.5	7.5-10	10-15	10-15	15-25

SHEARS—Motor *D* or *E*.

Width, in. . . . .	30-42	50-60	72-96
Horse-power to cut $1/8$ -in. iron. . . . .	3	4	5
Horse-power to cut $1/4$ -in. iron. . . . .	5	7.5	10

Bolt shears. . . . .  $7 1/2$  H.P. Double angle shears. . . . . 10 H.P.LEVER SHEARS—Motor *D* or *E*.

Size, in. . . . .	$1 \times 1$	$1 1/2 \times 1 1/2$	$2 \times 2$	$6 \times 1$	$2 1/2 \times 2 1/2$
Horse-power. . . . .	5	7.5	10	15	15
Size, in. . . . .	$1 \times 7$	$2 3/4 \times 2 3/4$	$1 1/2 \times 8$	$3 1/2 \times 3 1/2$	$4 1/2$ round
Horse-power. . . . .	15	20	25	30	30

PLATE SHEARS—Motor *D* or *E*.

Size of plate, in., $3/8 \times 24$ $1 \times 24$ $2 \times 14$ $1 \times 42$ $1 1/2 \times 42$ $1 1/4 \times 54$ $1 1/2 \times 72$ $1 1/4 \times 100$							
Cuts per min., 35 20	15	20	15	18	20	10-12	
Stroke, in., 3 3	$4 1/4$	4	$4 1/2$	6	$5 1/2$	$7 1/2$	
Horse-power, 10 15	30	20	60	75	10	75	

Hydrostatic Wheel Presses—Motor *B* or *C*.

Size, tons. . . . .	100	200	300	400	600
Horse-power. . . . .	5	7.5	7.5	10	15

**Grinding Machinery.**GRINDING MACHINES (FOR SHAFTS, ETC.)—Motor *A, B* or *C*.

Wheels diameter, in. . . . .	10	10	10	10	14	18	18	18
Length of work, in. . . . .	50	72	96	120	72	120	144	168
H.P., average work. . . . .	5	5	5	5	10	10	10	10
" heavy work. . . . .	7.5	7.5	7.5	7.5	15	15	15	15

EMERY WHEEL GRINDERS, ETC.—Motor *B* or *C*.

Number of wheels. . . . .	2	2	2	2	2	2
Size of wheels, in. . . . .	6	10	12	18	24	26
Horse-power. . . . .	$1/2-1$	2	3	5-7.5	7.5-10	7.5-10

MISCELLANEOUS GRINDERS—Motor *B* or *C*.

Wet tool grinder, 2 to 3 H.P.; flexible swinging grinding and polishing machine, 3 H.P.; angle cock grinder, 3 H.P.; piston rod grinder, 3 H.P.; twist drill grinder, 2 H.P.; automatic tool grinder, 3 to 5 H.P.

In selecting a motor for a machine tool, advantage should be taken of the fact that motors will stand considerable overloads for short periods. This will lead to the selection of smaller motors than are usual. The tendency is to select a motor to fit the maximum capacity of the machine, rather than one whose capacity is more nearly that of the average capacity of the tool.

A. G. Popcke (*Am. Mach.*, Sept. 26 and Oct. 3, 1912) outlines more accurate methods of determining the sizes of motors required for driving machine tools, based upon an analysis of the working conditions, and also the considerations other than those of power which govern the selection of the motor. To determine motor capacity, the following data are necessary: Horse-power, speed and voltage; and in addition for alternating current, frequency and phase. To estimate the horse-power the following must be known: Type of tool; depth of cut (all tools being considered), inches; feed, in. per revolution; speed, ft. per minute; duration of both average and maximum cuts; duration of peak of maximum load; number of peaks per hour. From the area of the cut (depth  $\times$  feed) and the cutting speed, the cubic inches of

metal removed per minute can be calculated for both average and maximum cuts, and these figures, multiplied by the constants below give the horse-power required, to which the friction load of the machine must be added.

## HORSE-POWER CONSTANTS FOR CUTTING METAL.

	H.P. per Cu. In. per Min.	H.P. per Cu. In. per Min.
Cast iron.....	0.3 to 0.5	Steel, 50 carbon or more.. 1.0 to 1.25
Wrought iron.....	0.6	Brass and similar alloys.. 0.2 to 0.25
Machinery steel.....	0.6	

These constants apply to round nose tools used in accordance with the conditions recommended by F. W. Taylor (see p. 1261). For twist drills the power requirements per cubic inch are about double the figures given above.

The size of the motor selected will depend on the heating of the motor while under load, and as the load is usually intermittent, the heating will depend upon the square root of the mean square value of the power required. In a given cycle in which the several power values are  $P_1, P_2, P_3$ , utilized during periods of  $t_1, t_2, t_3$ , respectively, the square root of the mean square will be

$$\sqrt{\frac{P_1^2 t_1 + P_2^2 t_2 + P_3^2 t_3}{t_1 + t_2 + t_3}}$$

The heating of the motor will be the same as if it were run constantly at a load equal to the square root of the mean square load. In making the motor selection, however, it should be observed whether or not the duration of the maximum load will be greater than the motor can successfully withstand. Thus a 100% overload for a period of 10 seconds can easily be carried by a properly designed motor, while if prolonged such a load may burn it out. When selecting motors for widely fluctuating intermittent loads, the limits above rated load which must be taken into consideration are for alternating current, pull at starting torque, and speed regulation; and for direct current motors, commutation, speed regulation and stability. The pull at the starting torque of an induction motor is from 2.5 to 3.5 times the full-load torque, and the speed regulation, or percentage drop in speed between no load and full load, known as the slip, is, at full load, from 5 to 7%. At other loads it is approximately proportional to the load. Commutating pole, direct current motors will stand 100% to 125% overload without sparking. The speed regulation at full load is 10 to 15%, depending on the speed of the motor. With non-commutating pole motors the speed decreases with overloads in proportion to the loads, while on commutating pole motors it increases up to 100% overload, thus giving approximately the same speed at double load as at full load. A commutating pole motor can be made stable at overloads, which will increase the drop in speed. The better the speed regulation, however, the less certain is the stability and the motor for driving machine tools must be a compromise between these two factors. Motors, however, are available which can be safely operated on intermittent loads where the maximum load is 200% of the rated load. In machine tool work, a large speed reduction, giving a stable motor is advisable when variations occur in the work done by the cutting tool on long jobs, thus protecting the cutting tools, the machines and the work. An adjustable speed motor with a speed reduction of 25% is of advantage under such circumstances.

In applying the principles outlined above to the selection of a machine tool motor, the average and maximum conditions of service of the machine should be determined by laying out typical jobs in which these conditions are present. The power cycles are determined from the amount of metal removed on each cut as previously explained and the duration of each cut is ascertained from the length of the cut, the spindle speed and the feed per revolution. The square root of the mean square value of the power required is next determined, the time while the machine is idle during the periods of adjustment being added in the denominator of the formula for this value. A motor whose

capacity is in the neighborhood of the value ascertained is then selected, and the relation of the maximum load to the rated motor capacity is observed to ascertain whether or not the motor, in addition to carrying the average load, is capable of carrying the maximum load without injury. For instance, if the square root of the mean square value is 5.5 H.P. a 5-H.P. motor would be under an overload of 10%, which is well within the capacity of a well designed machine. If the maximum load requires 8.3 H.P. for a period of three minutes the motor will be overloaded 66% for this period which is also within the limits set by good motor design.

According to Mr. Popcke, other questions than horse-power govern the selection of a motor for a machine tool. The speed of the motor depends upon the speed of the machine shaft, which ranges from 50 to 60 r.p.m. on forging machines to 200 to 300 r.p.m. on machine tools, and as high as 1000 to 2000 r.p.m. on grinding and wood-working machinery. The speeds usually obtainable with 60-cycle alternating current motors are 1700-1800, 1100-1200, 850-900, 650-720 and 550-600 r.p.m. The speeds available on standard direct current motors are approximately the same. On 25-cycle alternating current motors the usual speeds are 700-750, 550-600, and 350-375 r.p.m. The following factors are considered in selecting motors for belt drives: Speed reductions, pulley sizes, belt speeds, motor speeds, distance between pulley centers, arc of contact, use of idler pulleys, mounting of motor. Involved in the speed reductions are the sizes of the motor and machine pulleys and the belt speed. The standard sizes of motor pulleys which have been adopted in connection with standard speed ratings of the various sizes of motors have standardized the belt speeds. The maximum and minimum standard speed ratings of the motors, together with the maximum and minimum pulley diameters are given in the following table:

HORSE-POWER OF MOTOR.												
1	2	3	5	7 1/2	10	15	20	25	30	35	40	50
R.P.M., MAXIMUM.												
1700	1700	1800	1800	1700	1700	1700	1700	1400	1700	1700	1700	1700
Pulley Diameter, standard.												
3 1/2	3 1/2	4	4	5	6	7	8	9	9	10	11	11
Pulley Diameter, minimum.												
3	3	3	3 1/2	4	4 1/2	5	6	6 1/2	6 1/2	7	7 1/2	8
R.P.M., MINIMUM.												
....	850	850	850	650	600	600	650	600	600	675	600	565
Pulley Diameter, standard.												
....	4	5	6	8	9	11	11	12	13	13	14	16
Pulley Diameter, minimum.												
....	3 1/2	4	4 1/2	6	6 1/2	7 1/2	8	9	10	10	12	13 1/2

The minimum size of pulley is specified on account of the reduction of pulley size increasing the strains on the motor bearings and shaft. The arc of contact has great effect on the success of a belt-driven motor installation. The arc of contact depends on the distance between the pulley centers and on the speed reduction. Where it is necessary to increase the arc of contact, idler pulleys are of service. In machine work the size of the motor pulley is sometimes fixed by the necessity of belting the motor to the machine flywheel, in which case care must be taken that the diameter of the motor pulley is not less than the minimum size specified. The arc of contact must also be considered, as in a large speed reduction this will be decreased and will seriously affect the amount of power transmitted. The effect of decreasing the arc of contact is shown below, the power transmitted by a 180 deg. arc of contact being taken as 100.

Arc of contact, deg. . . .	180	170	160	150	140	130	120
Power transmitted, % . . .	100	94	89	83	78	72	67

The cost of a motor per horse-power increases as the speed decreases. Therefore, for maximum economy in first cost as high a speed as possible should be selected without, however, going below the minimum pulley diameter. Back geared motors are useful where extremely low speeds are required. A speed ratio of 6:1 between the armature and the motor countershaft is usually satisfactory, any further speed reduction to the machine pulley being obtained by means of the pulley



Data for Standard Geared Connections for Constant Speed Motors.

Horse-Power.	Maximum Speed Rating.							Minimum Speed Rating.						
	R.P.M.	Diam. Pitch.	No. of Teeth.			Std. Pitch Line Speed.	Min. Diam., in.	R.P.M.	Diam. Pitch.	No. of Teeth.			Std. Pitch Line Speed.	Min. Diam., in.
			Standard Pinion.	Min. Raw-hide Pinion.	Min. Steel Pinion.					Standard Pinion.	Min. Raw-hide Pinion.	Min. Steel Pinion.		
1	1700	8	17	15	13	940	1.63	1200	8	17	15	13	665	1.63
2	1700	8	17	15	13	940	1.63	850	6	18	21	19	615	2.38
3	1800	8	22	20	19	1300	2.38	850	6	18	18	18	670	3.0
5	1800	8	22	21	19	1300	2.38	850	6	21	19	18	990	3.0
7.5	1700	6	18	18	18	1400	3.0	650	5	20	18	18	685	3.6
10	1700	6	21	19	18	1420	3.0	600	5	21	19	19	665	3.8
15	1700	5	19	18	18	1700	3.6	600	4 1/2	22	19	19	770	4.22
20	1700	5	20	18	18	1780	3.6	650	4	21	18	18	890	4.5
25	1400	5	21	19	19	1550	3.8	600	4	22	19	18	864	4.5
30	1700	5	21	19	19	1880	3.8	600	3 1/4	20	....	18	970	5.53
35	1700	4 1/2	22	18	18	2180	4.0	675	3 1/4	20	....	18	1080	5.53
40	1700	4 1/2	22	19	19	2180	4.22	600	3	18	....	15	940	5.0
50	1700	4	21	18	18	2340	4.5	565	3	20	....	18	990	6.0

Data for Standard Geared Connections for Adjustable Speed Motors.

Horse-Power.	Maximum Speed Rating.							
	Min. R.P.M. of Motor.	Speed Ratio.	Min. Diam. of Pulley, in.	Gear Data.			Pitch Line Speed at Min. Diam.	
				Min. No. of Teeth.	Min. Diam., in.	Diam. Pitch.	Min.	Max.
1	740	3	3	19	2.38	8	460	1380
2	1100	2	3	19	2.38	8	690	1380
3	1000	2	3	19	2.38	8	625	1250
5	1000	2	4	18	3.0	6	790	1580
7 1/2	900	2	5	18	3.0	6	705	1410
10	850	2	6	18	3.6	5	800	1600
15	780	2	6 1/2	19	3.8	5	780	1560
20	650	2	7 1/2	19	4.22	4 1/2	720	1440
25	550	2	9	18	4.5	4	645	1290
30	550	2	10	18	5.53	3 1/4	800	1600
40	550	2	12	15	5.0	3 1/2	720	1440
50	500	2	12 1/2	18	6.0	3	790	1580

Horse-Power.	Minimum Speed Rating.							
	Min. R.P.M. of Motor.	Speed Ratio.	Min. Diam. of Pulley, in.	Min. No. of Teeth.	Min. Diam., in.	Diam. Pitch.	Min.	Max.
1	450	4	3	19	2.38	8	280	1120
2	450	4	4	18	3.0	6	355	1420
3	375	4	5	18	3.0	6	294	1176
5	375	4	6	18	3.6	5	355	1420
7 1/2	350	4	6 1/2	19	3.8	5	350	1400
10	375	4	7	18	4.0	4 1/2	390	1560
15	375	4	9	18	4.5	4	440	1760
20	300	4	12	15	5.0	3	390	1560
25	300	4	12 1/2	18	6.0	3	470	1880
30	250	4	14	18	6.0	3	390	1560
40	250	4	16	19	6.33	3	415	1660
50	325	3	16	19	6.33	3	540	1620

on the motor countershaft. Back geared motors are used where the machine speed is below 150 to 100 r.p.m. The initial speed of the back geared motor should not exceed 1200 r.p.m. when the horse-power is from 10 to 20 and should not exceed 900 or even 720 r.p.m. when the horse-power is greater than this figure.

For equipment where the motor is geared to the machine, the following are the governing considerations: Speed reduction, pitch line speed, number of teeth on gears, width of face of gears, center distances, use of idler gears, motor mounting. Noise limits the pitch line speed to about 1000 feet per minute with steel gears. For speeds of 1000 to 2000 feet per minute, cloth or rawhide pinions should be used and speeds in excess of 2000 feet per minute should be avoided if possible. Stresses in bearings and motor shafts limit the minimum size of motor pinions just as they limit the size of pulleys. The maximum and minimum speed ratings and the corresponding standard and minimum sizes of pinions for constant speed and adjustable speed motors are given in the tables on the preceding page. The second table also gives the minimum pulley diameters for adjustable speed motors.

For additional data on machine tool motors see *Electrical Engineering*, p. 1466.

**Motor Requirements for Milling Machines.**—See p. 1278.

**Power Required for Drilling.**—See p. 1286.

**Motor Requirements of Planers.** (A. G. Popcke, *Am. Mach.*, Sept. 26, 1912.)—Manufacturers usually specify motors for planers that are larger than necessary, due to the heavy peak load imposed at the instant of reversal. Before the advent of interpole, commutating motors, this peak load caused sparking unless a large motor was used. The commutating motor eliminates this trouble and permits the use of a smaller motor. A flywheel on the countershaft, from which the forward and reverse belts are driven, will assist in the carrying of the peak loads, and will allow the use of a smaller driving motor than otherwise. The table below shows the results of tests of planers with a graphic recording ammeter, and gives the power required at different portions of the planer cycle. It also shows the motors recommended and installed, which are handling the work satisfactorily, and also the size of motors specified by the makers of the tools.

**Power Requirements of Planers.**

Size of Planer.		Motor Used for Test.	Observed Power Requirements.				Remarks.	Motor Installed, Based on Test.	Motor Specified.
			Cut Stroke.	Return Stroke.	Reversal to Cut.	Reversal to Return.			
In.	Ft.	H.P.	K.W.	K.W.	K.W.	K.W.	H.P.	H.P.	
56	× 15	3	1.3	3.5	4.0	5.3	Average work 5 Tons on table Short stroke	5	15
"	"	5	1.8	2.8	3.5	5.3			
"	"	5	2.5	.....	6	6			
54	× 16	30	4	6	8	10.5	Average stroke Short stroke	5	15
"	"	30	4	7	10	12			
"	"	5	1.8	2.3	3.5	5.5	Average stroke	7 1/2	15
48	× 12	5	2	7	8	9	Average work		
24	× 10	7 1/2	2	4.5	4.3	5.5	Motor geared balance wheel	5	7 1/2
42	× 12*	5	1.5	2.5	5	7			
48	× 12	30	5	10	14	19	Average work No. bal. wheel	7 1/2	15
37	× 8	5	1.8	3	4	6	Average work		
36	× 8	5	1.5	2	2.5	4	"	3	5
36	× 8	5	1.8	2	3	5	"	3	5

\* Open side.

The Cincinnati Planer Co. has furnished the author with the results of a test of 72 in. × 24 ft. planer, fitted with a reversible motor drive, cutting cast iron. To run the table in the direction of the cut required

2.06 H.P.; reversing from cutting to return stroke, 13 H.P.; reversing from return to cutting stroke, 14.4 H.P.

**Test on 72 × 24-in. Reversible Motor-Driven Planer.**

Depth of Cut, In.	Feed, In.	Number of Tools Cutting.	Cutting Speed, Ft. per Min.	H.P. Required, Including Friction.	Pressure per Sq. In. in Cast Iron.
1/2	3/16	2	30	23	123,200
1/2	3/16	2	40	26.7	108,680
1/2	3/16	2	60	37.5	104,133
1/2	3/32	2	30	11.5	111,419
1/2	3/32	2	60	23	123,200
1/4	3/16	2	30	10.1	95,090
1/4	3/16	2	60	20.2	106,830
1/4	3/32	2	30	7.3	124,572
1/4	3/32	2	60	14.4	145,726

**Power Required for Wood-Working Machinery.** (E. G. Fox, *El. Rev.*, June 13, 1914.)—The factors influencing the power required for wood-working machines are: Design, speed of working, including feed and depth of cut, condition of machine and cutters, nature of material. Machines handling one kind of material may be motored for their ordinary load, while those having diverse work must be motored for their heaviest service. The data below are based upon tests as well as on figures furnished by manufacturers.

**Band Saws.**—The motors should have good starting torque, and with resaws should be capable of developing 1.5 full load torque at starting, and should have good overload characteristics. Belted motors are recommended for most installations.

**BAND-SAWS.**

Wheel diameter, in. . . . .	42	38	36	36	34	30
R.P.M. . . . .	400-500	450	500	400	500	500
Maximum depth of timber, in. . . . .	20	16	16	14	12	12
H.P. of motor . . . . .	5	5	5	3	3	3

**BAND-RESAWS.**

Wheel diameter, in. . . . .	60	54	48	44	42	40	38
R.P.M. . . . .	550	600	650	650	650	700	450
Width saw blade, in. . . . .	8	6	5	4	4	3	2
Maximum depth of timber, in. . . . .	36	30	26	24	24	20	12
H.P. of motor . . . . .	50	40	30	20	15	15	7.5
R.P.M. of motor . . . . .	600	600	720	720	720	720	514

Add for jointing attachment on 48-in. saw, 7.5 H.P.

**BAND RIP SAWS—POWER FEED.**

Wheel Diam., in.	R.P.M.	Max. Timber Depth, in.	Motor H.P.	Motor R.P.M.
42	650	12	15	720
40	600	15	10	600

Add 2 H.P. for return rolls, if used. Speeds given are for direct connection.

**Circular Saws.**—Circular saws are not as widely used as band-saws for resawing, as they require more power, run at lower speeds and waste more stock. Splitting with circular saws requires from 15 to 20% more power than cross-cutting. Band-saws require about the same power for both.

**CIRCULAR SAWS.**

Maximum diameter of saw, in. . . . .	42	36	32	30	24
R.P.M. of saw . . . . .	900	1000	1225	1200	1225
Maximum capacity, in., horizontal . . . . .	17	14	11	10	8
“ “ “ vertical . . . . .	“	“	8	6	6
Horse-power . . . . .	25	25	20	20	20



## CIRCULAR RIP-SAWS.

Maximum diameter of saw, in.....	20	16	12
Maximum R.P.M. of saw.....	2100	2600	2400
Maximum thickness of stock, in.....	6	5	2
Feed, ft. per min.....	60-180	64-194	50-100
Horse-power.....	15	15	7.5

## HAND-FEED CIRCULAR RIP-SAWS.

Maximum diameter of saw, in. . . . .	14	16	20	24	30	36
R.P.M. of saw.....	2700	2400	2000	1600	1250	1000
Horse-power.....	7.5	10	15	15	20	20

## POWER-FEED GANG RIPPING-MACHINE.

Number of saws.....	2	3	4	8
Maximum R.P.M.....	3400	2300	2500	2500
Diameter of saws, in.....	10	15	14	14
Feed, ft. per min.....	180	200	100-180	90-200
Horse-power.....	15	30	25	35

## CIRCULAR CUT-OFF SAWS.

Maximum saw diameter, in.....	14	16
R.P.M. of saws.....	2700	2600
Horse-power.....	5	7.5

## INSIDE MOLDERS.

Maximum capacity, in.....	8 × 4	10 × 4	12 × 6	14 × 6
Horse-power.....	25	25	35	35

## OUTSIDE MOLDERS.

Maximum capacity, in. . . . .	4 × 4	6 × 4	8 × 4	10 × 4	12 × 5	14 × 6
Horse-power.....	10	15	20	25	30	35

## STICKERS.

Maximum size of timber, in... .	16 × 4	18 × 4	20 × 4
Horse-power.....	5	7.5	10

## JOINTERS.

Maximum width of timber, in.....	8	12	16	20	24	36
Horse-power.....	2	2	3	5	7.5	7.5

The recommendations for molders, stickers and jointers are based on a maximum depth of cut of  $\frac{3}{32}$  in. If the cut is greater, the size of motor should be correspondingly increased.

*Surfacers.*—The motor sizes given below are for medium work with maximum depths of cut of  $\frac{1}{8}$  in. For planing mill work, on heavy stock with deep cuts the sizes should be increased about 5 H.P.

## SINGLE SURFACERS.

Maximum width of timber, in. . . . .	16	20	24	30	36
Horse-power.....	7.5	10	10	15	15

## DOUBLE SURFACERS.

Maximum width of timber, in.....	26	30	36
Horse-power, heavy work.....	35	35	..
Horse-power, medium work.....	20	25	30

*Timber Sizers.*—The following figures apply to heavy service in dressing timber to size, surfacing four sides simultaneously.

Max. size of timber, in.. . . .	20 × 16	20 × 18	20 × 20	30 × 18	30 × 20
Horse-power.....	60	60-75	60-75	75	75

## DRUM SANDERS.

Number of drums.....	1	1	1	2	2	2
Max. Width of Stock, in.....	30	36	42	30	36	42
Horse-power.....	10	15	15	20	20	25
Number of drums.....	3	3	3	3	3	3
Maximum width of stock, in... .	30	36	42-48	54-66	72	78
Horse-power.....	20	25	30	35	40	40

When material is sanded to size and full width of sander is used with panels fed continuously, add 5 H.P. to above motor sizes.

## TENONERS—HAND-FEED.

Length of tenon, in.....	7 single	7 double
Horse-power.....	7.5	10

*Shapers.*—For ordinary service on reversible single- or two-spindle machines, use a 5 H.P. motor. For extra heavy work, as in carriage factories, railroad shops, etc., use a 7.5 H.P. motor.

SCRAPING MACHINES.

Maximum width of stock, in. . . . .	12	26	30	42
Horse-power . . . . .	2	3	3	5

AUTOMATIC LATHES.

Maximum diameter and length of stock, in. . . . .	2.75 × 72	3 × 50	5 × 50
Horse-power . . . . .	10	15-20	20

BORERS.

Number of bits . . . . .	1	1	2	3	4	8
Maximum diameter of bits, in. . . . .	1	2	0.75	0.75	0.5	0.5
Horse-power . . . . .	3	5	3	5	5	10

CHISEL MORTISING-MACHINES.

Maximum number of chisels . . . . .	1	1	1	1	2
Maximum size of chisel square, in. . . . .	0.5	0.75	0.75	1.25	1
Horse-power . . . . .	2	2	3	5	3
Maximum number of chisels . . . . .	3	4	5	6	7
Maximum size of chisel square, in. . . . .	1	1	1 <sup>3</sup> / <sub>16</sub>	1 <sup>3</sup> / <sub>16</sub>	1 <sup>3</sup> / <sub>16</sub>
Horse-power . . . . .	5	5	5	7.5	7.5

PLANERS AND MATCHERS.

For planing and matching timber at one operation.

Maximum size of timber, in. . . . .	9 × 6	15 × 6	20 × 6	24 × 6	26 × 8
Horse-power . . . . .	35	40	45	45	45

Box board matchers are similar to planers and matchers, but the work is much lighter. Hand-fed machines usually require a 7.5 H.P. motor, while power-fed machines require 10 H.P.

**Horse-power Required to Drive Shafting.**—Samuel Webber in his "Manual of Power" gives, among numerous tables of power required to drive textile machinery, a table of results of tests of shafting. A line of 2<sup>1</sup>/<sub>8</sub>-in. shafting, 342 ft. long, weighing 4098 lb., with pulleys weighing 5331 lb., or a total of 9429 lb., supported on 47 bearings, 216 revolutions per minute, required 1.858 H.P. to drive it. This gives a coefficient of friction of 5.52%. In seventeen tests the coefficient ranged from 3.34% to 11.4%, averaging 5.73%. J. T. Henthorn states (*Trans. A. S. M. E.*, vi, 462) that in print-mills which he examined the friction of the shafting and engine was in 7 cases below 20% and in 35 cases between 20% and 30%, in 11 cases from 30% to 35% and in 2 cases above 35%, the average being 25.9%. Mr. Barrus in eight cotton-mills found the range to be between 18% and 25.7%, the average being 22%. Mr. Flather (Dynamometers) believes that for shops using heavy machinery the percentage of power required to drive the shafting will average from 40% to 50% of the total power expended. Under the head of shafting are included elevators, fans and blowers.

**Power Required to Drive Machines in Groups.**—L. P. Alford (*Am. Mach.*, Oct. 31, 1907) gives the results of an investigation to determine the power required to drive machinery in groups. The method employed comprised disconnecting parts of the shafting in a belt-driven plant, and driving the disconnected portion with its machines by an electric motor, readings of the power required being taken every 5 minutes. The average power required for the entire factory was considerably less than the sum of the power required for the individual machines, due to tools being stopped at some portion of the day for adjustment, replacement of work, etc. The conditions of group driving are such that fixed rules cannot be laid down, but a study must be made of each individual case. The results of the several thousand observations made in the investigation are given in the accompanying table. The observations were made before the introduction of high speed steel, and the figures probably should be modified somewhat for more modern practice. The sum of the individual horse-power values as given in the table is about 20% higher than the power actually used in the factory, due to a lessening of the average horse-power in each department. The reason for this is the working conditions existing, in that all tools were not used to their maximum or even average

capacity at the same time. In determining the size of motor for each department, the total horse-power required by the tools in that department, as given in the table, was diminished by 20%, and the friction load of line and countershafts was added.

### Power Required by Machine Tools in Groups.

Size.	Maximum H.P.	Average H.P.	Size.	Maximum H.P.	Average H.P.	Size.	Maximum H.P.	Average H.P.
<b>Boring Machines.</b>			<b>Grinders (Cont.)</b>			<b>Milling Machines (Cont.)</b>		
36 in. <sup>1</sup>	0.78	0.52	Note 16	3.29	0.97	No. 7	.....	0.83
42 " <sup>2</sup>	1.72	1.08	" 17	.....	0.41-0.82	" 14	.....	0.25
<b>Cam Cutters.</b>			<b>Drop Hammers.</b>			<b>Planers.</b>		
No. 2	.....	0.67	40 lb.	.....	0.10	" 15	.....	0.25
" 4	0.48	0.32	250 "	.....	2.00	" 3 <sup>26</sup>	.....	0.26
" 5	0.48	0.32	400 "	.....	2.50	" 5 <sup>26</sup>	.....	0.55
Note 3	.....	0.32	600 "	.....	3.00	" 3	.....	0.17-0.25
" 4	.....	0.32	800 "	.....	3.50	" 1	.....	0.15
<b>Cutting-off Machine.</b>			<b>Power Hammers.</b>			<b>Lathes.</b>		
1 15/16 in.	.....	0.12	1000 "	.....	4.00	20 in. <sup>18</sup>	.....	0.35
2 in.	0.28	0.14-0.18	1500 "	.....	5.00	30 " <sup>18</sup>	.....	0.41
3 in.	0.34	0.20-0.22	<b>Keyseater.</b>			12 "	.....	0.24
<b>Drilling Machines.</b>			<b>Keyseater.</b>			14 "	0.48	0.26
Note 5	.....	0.72	No. 4	0.64	0.28-0.32	16 "	.....	0.34
" 6	3.18	1.12	<b>Lathes.</b>			16 "	0.48	0.36
" 7	.....	0.31	20 in. <sup>18</sup>	.....	0.35	18 "	.....	0.39
" 8	.....	0.32	30 " <sup>18</sup>	.....	0.41	20 "	.....	0.44
" 9	.....	0.35	12 "	.....	0.24	22 "	0.37	0.32
" 10	.....	0.48	14 "	0.48	0.26	24 "	.....	0.25
" 11	.....	0.71	16 "	.....	0.34	24 "	.....	0.31
16 in.	.....	0.25	16 "	0.48	0.36	28 "	.....	0.31
18 "	.....	0.35	18 "	.....	0.39	38 "	.....	0.58
20 "	.....	0.42	20 "	.....	0.44	10 " <sup>19</sup>	.....	0.10
22 "	.....	0.59	22 "	0.37	0.32	14 " <sup>19</sup>	.....	0.12
24 "	.....	0.47	24 "	.....	0.25	15 " <sup>20</sup>	.....	0.25
26 "	.....	0.22	24 "	.....	0.25	<i>H</i> <sup>21</sup>	.....	0.70
28 "	.....	0.25	24 "	.....	0.31	No. 1 <sup>22</sup>	1.63	0.33-0.63
30 "	.....	0.30	28 "	.....	0.31	2 × 24 in. <sup>23</sup>	1.97	1.20-1.80
34 "	.....	0.45	38 "	.....	0.58	14 in. <sup>24</sup>	.....	0.31
36 "	.....	0.53	10 " <sup>19</sup>	.....	0.10	16 " <sup>24</sup>	.....	0.36
46 "	.....	0.63	14 " <sup>19</sup>	.....	0.12	36 " <sup>25</sup>	1.50	1.30
50 "	.....	0.83	15 " <sup>20</sup>	.....	0.25	<b>Milling Machines.</b>		
<b>Gear Cutters.</b>			<b><i>H</i><sup>21</sup></b>			<b>Milling Machines.</b>		
No. 4 1/2	.....	0.15-0.32	<i>H</i> <sup>21</sup>			No. 1	0.47	0.30
" 3	.....	0.20	<i>H</i> <sup>21</sup>			" 3	0.64	0.26
" 3	.....	0.20	<i>H</i> <sup>21</sup>			" 4	.....	0.19-0.29
<b>Grinders.</b>			<b><i>H</i><sup>21</sup></b>			" 4 1/2	.....	0.13-0.19
No. 3 <sup>12</sup>	.....	0.32	<i>H</i> <sup>21</sup>			" 6	.....	0.26
" 4	1.42	0.53	<i>H</i> <sup>21</sup>			<b>Band-Saw.<sup>30</sup></b>		
" 11 <sup>13</sup>	.....	0.80	<i>H</i> <sup>21</sup>			36 in.	3.00	0.87
" 2 <sup>14</sup>	.....	0.40	<i>H</i> <sup>21</sup>			<b>Circular Saw.</b>		
" 3 <sup>14</sup>	.....	0.50	<i>H</i> <sup>21</sup>			9 in.	3.77	1.05
" 1 <sup>15</sup>	.....	0.60	<i>H</i> <sup>21</sup>			13 "	3.75	1.04
" 2 <sup>15</sup>	.....	0.76	<i>H</i> <sup>21</sup>			13 "	5.82	1.21
<b>Grinders.</b>			<b><i>H</i><sup>21</sup></b>			<b>Hack Saw.</b>		
<b>Grinders.</b>			<b><i>H</i><sup>21</sup></b>			12-14 in.	.....	0.06
<b>Grinders.</b>			<b><i>H</i><sup>21</sup></b>			<b>Screw Machines.</b>		
<b>Grinders.</b>			<b><i>H</i><sup>21</sup></b>			No. 1	.....	0.60
<b>Grinders.</b>			<b><i>H</i><sup>21</sup></b>			" 2	.....	0.37
<b>Grinders.</b>			<b><i>H</i><sup>21</sup></b>			" 2	.....	0.72

NOTES.—<sup>1</sup> Single head. <sup>2</sup> Double head. <sup>3</sup> Lathe type, single head. <sup>4</sup> Lathe type, double head. <sup>5</sup> No. 0 radial. <sup>6</sup> No. 1 radial. <sup>7</sup> Single spindle, sensitive. <sup>8</sup> 2-spindle. <sup>9</sup> 3-spindle, sensitive. <sup>10</sup> 4-spindle. <sup>11</sup> 6-spindle. <sup>12</sup> Cutter and reamer. <sup>13</sup> Plain. <sup>14</sup> Surface. <sup>15</sup> Universal. <sup>16</sup> Wet tool, carrying 20-in. wheel. <sup>17</sup> Wet grinder with two 24-in. wheels. <sup>18</sup> Boring lathe. <sup>19</sup> Speed lathe. <sup>20</sup> Squaring-up lathe. <sup>21</sup> Gisholt turret lathe. <sup>22</sup> Potter & Johnson semi-automatic. <sup>23</sup> Jones & Lamson flat turret. <sup>24</sup> Wood turning. <sup>25</sup> Putnam gap lathe, used for wood turning. <sup>26</sup> Vertical. <sup>27</sup> Hand. <sup>28</sup> Wood panel planer. <sup>29</sup> Wood surfacer. <sup>30</sup> Used for pattern work.



A similar investigation, reported by H. C. Spillman (*Mach'y*, June, 1913), showed that but 20% of the total power supplied to the motor is applied in useful work in the machines, 72% being absorbed in friction losses in machines and shafting, and 8% disappearing as electrical losses.

### MACHINE TOOL DRIVES, SPEEDS AND FEEDS.

**Geometrical Progression of Speeds and Feeds.**—It has become generally accepted that the speeds available on a given machine tool should be in a geometric progression. There is, however, by no means a uniformity in the ratio of the various geometric series adopted by the different makers. This ratio will be found to range from 1.3 to 1.7 on the usual types of cone-driven machines, and the speeds available under different conditions of open belt and back gear operation present many duplications and are often far from a true geometric progression when considered over the entire range of speeds. Carl G. Barth (*Am. Mach.*, Jan. 11, 1912) suggests a ratio of  $\sqrt[4]{2} = 1.189$ . With this ratio, the revolutions per minute of the spindle are doubled every fourth speed. An editorial (*Am. Mach.*, Dec. 3, 1914) discussing the advantage of adopting this ratio for a speed series shows that it will fulfill all the ordinary requirements of machine tool work, and that practically any desired speed in either lathe or drill press can be obtained when the machine is speeded according to a geometric progression based on the ratio 1.189. At the present writing (1915) this ratio has been adopted by several machine tool builders.

The necessity for the adoption of a standard ratio for speeds and feeds on machine tools is discussed in *Am. Mach.*, Dec. 3 and 10, 1914, in describing the respeeding of machines at the Watertown arsenal and elsewhere. The speeds originally available on many of the machines presented many duplications of open belt speeds when back-gearred, and the speeds on any one machine considered as a whole were not in any regular series. Thus a lathe with supposedly 20 speeds had practically, due to duplication of speeds in the open belt and back-gear series, only 12 speeds. The rearrangement of the gearing and the pulleys made all 20 speeds available, and in practical accord with a geometric series with a ratio of 1.189. In the same article there are tabulated the speeds of nine 16-in. lathes offered in response to a request for bids. In no case did the speeds available on one lathe correspond with those on any other, nor did any set of speeds even approximate the ideal speeds. Even three machines offered by one maker had wide variations in their speeds. Such a condition precludes the possibility of using machines interchangeably for the same service, and, as stated by Mr. Barth, is the basis of much of the trouble regarding piece rates in machine shop work. See also article by Robert T. Kent, *Iron Age*, July 3, 1913.

A geometrical progression of the feeds available on machine tools is also desirable, and Mr. Barth has recommended the same ratio for the feed series as for the speed series,  $\sqrt[4]{2} = 1.189$ . The reasons for adopting this ratio are given in the article above cited, *Am. Mach.*, Jan. 11, 1912.

**Methods of Driving Machine Tools.**—F. A. Halsey in a lecture at Columbia University (*Indust. Eng.*, Sept., 1914) compares the relative advantages of the ordinary 5-step cone pulley, the 3-step cone pulley, the constant speed pulley and the individual motor as a drive for machine tools. In the 5-step cone pulley drive the large intervals between the speeds available on the different cone steps decrease the output of the machine, due to the fact that except in those few cases where the cone speed is nearly equal to the cutting speed the next lower cone speed must be used. Also on account of the proportions of the cone, the belt speed is unnecessarily low, and as the belt is moved to the largest cone step its speed is still further decreased. On the larger steps the belt is frequently incapable of delivering the power required by the heavier cuts which go with large work. This defect is remedied in the 3-step cone pulley, in which the difference in the diameters of the steps is not so pronounced, the additional number of speed changes being obtained by double back gears.

Mr. Halsey compares two specific cases: (1) A 5-step cone with single back gears, the cone step diameters being respectively 4, 6, 8, 10,

and 12 in. (2) A 3-step cone with double back gears, the cone step diameters being respectively  $11 \frac{17}{32}$ ,  $12 \frac{9}{32}$ , and 13 in. In case 1 a  $2 \frac{1}{2}$ -in. belt, and in case 2 a 4-in. belt, is used. The change from 3 to 5 steps reduces the ratio of the highest to the lowest speed on the cone, and it increases the belt speed and therefore the power on all steps, but particularly on the large ones where it is most needed. The effect of these changes can be shown by calculating the respective powers with the belts on the largest steps of the two cones. Assume (case 1) that the speed with the belt on the 4-in. step is 100. Then the speed with the belt on the largest step will be  $100 \times \frac{4}{12} = 33 \frac{1}{3}$ . To maintain the same cone speed in case 2, the highest belt speed will be  $100 (11 \frac{17}{32} \div 4) = 288 +$ ; the lowest will be  $288 (11 \frac{17}{32} \div 13) = 255 +$ . The smallest step in case 1 is too small for a double belt, while in case 2 a double belt can be used on the smallest step. In order to compare the power capacities of the two machines the belt speed must be multiplied by a factor representing the greater pulling power of the double belt, say 1.43, and also by the ratio of the belt widths, 1.6. If  $L_1$  and  $L_2$  represent respectively the power capacities of the large steps of cases 1 and 2, and  $S_1$  and  $S_2$  the power capacities of the small steps, then

$$\frac{S_2}{S_1} = \frac{288}{100} \times 1.43 \times 1.6 = 6.5$$

$$\frac{L_2}{L_1} = \frac{255}{33.33} \times 1.43 \times 1.6 = 17.5$$

That is, the power capacity of the 3-step cone is 6.5 times as great as that of the 5-step cone with the belt on the small step, and 17.5 times as great with the belt on the large step. The defect of the arrangement given in case 2 is that it provides a smaller number of speeds and a smaller range of speeds than does case 1. The remedy is the provision of additional back gears if the additional speeds or greater range is necessary. Mr. Halsey further points out that direct connection between the cone pulley and the work spindle has been retained in many cases where it should have been discarded, since with large work the belt speed will become too low to transmit adequate power, and it is better practice to interpose gearing between the pulley and the spindle, and thus speed up the belt and pulley. In changing machines in accordance with the above suggestions, it is advisable to so design the gearing as to obtain speeds which will be in geometric progression as explained in a previous paragraph. For methods of laying out cone pulleys, see p. 1136. For methods of laying out the driving gears of machine tools see "Halsey's Handbook for Machine Designers and Draftsmen," p. 77.

*In the Constant Speed Pulley drive*, the belt pulley of the machine is driven at a constant speed and the power is transmitted to the machine from the pulley through a train of gears arranged in a gear box. By the shifting of appropriate levers any particular set of gears can be put in engagement, thus making instantly available any speed in the range of the machine. This arrangement makes the obtaining of a geometric series of speeds a particularly easy matter. The constant speed pulley drive possesses the advantage of giving a self-contained machine, particularly adapted to the individual motor drive. It has found wide application in the milling machine and in certain types of lathes.

*The Individual Motor Drive* has, according to Mr. Halsey, a field in the driving of portable floor plate tools, for machines in isolated positions, or for tools so located that line shafts cannot be conveniently laid out for them, and for large machines where the cost of the motor is a relatively small part of the total cost of the tool. The disadvantage of the individual motor for the small or medium size tool is that the power capacity of the motor must be equal to the maximum power requirement of the machine and that no advantage can be taken of the average power requirements of several machines as is possible in the group drive where one motor drives several machines. This increases the first cost of the motors, and they are also usually worked at low efficiency, due to the fact that they are most of the time underloaded.

## ABRASIVE PROCESSES.

Abrasive cutting is performed by means of stones, sand, emery, glass, corundum, carborundum, crocus, rouge, chilled globules of iron, and in some cases by soft, friable iron alone. (See paper by John Richards, read before the Technical Society of the Pacific Coast, *Am. Mach.*, Aug. 20, 1891, and *Eng. & M. Jour.*, July 25 and Aug. 15, 1891.)

**The "Cold Saw."**—For sawing any section of iron while cold the cold saw is sometimes used. This consists simply of a plain soft steel or iron disk without teeth, about 42 inches diameter and  $\frac{3}{16}$  inch thick. The velocity of the circumference is about 15,000 feet per minute. One of these saws will saw through an ordinary steel rail cold in about one minute. In this saw the steel or iron is ground off by the friction of the disk, and is not cut as with the teeth of an ordinary saw. It has generally been found more profitable, however, to saw iron with disks or band-saws fitted with cutting-teeth, which run at moderate speeds and cut the metal as do the teeth of a milling-cutter.

**Reese's Fusing-disk.**—Reese's fusing-disk is an application of the cold saw to cutting iron or steel in the form of bars, tubes, cylinders, etc., in which the piece to be cut is made to revolve at a slower rate of speed than the saw. By this means only a small surface of the bar to be cut is presented at a time to the circumference of the saw. The saw is about the same size as the cold saw above described, and is rotated at a velocity of about 25,000 feet per minute. The heat generated by the friction of this saw against the small surface of the bar rotated against it is so great that the particles of iron or steel in the bar are actually fused, and the "sawdust" welds as it falls into a solid mass. This disk will cut either cast iron, wrought iron, or steel. It will cut a bar of steel  $1\frac{3}{8}$  inch diameter in one minute, including the time of setting it in the machine, the bar being rotated about 200 turns per minute.

**Cutting Stone with Wire.**—A plan of cutting stone by means of a wire cord has been tried in Europe. While retaining sand as the cutting agent, M. Paulin Gay, of Marseilles, has succeeded in applying it by mechanical means, and as continuously as formerly the sand-blast and band-saw, with both of which appliances his system—that of the "helicoidal wire cord"—has considerable analogy. An engine puts in motion a continuous wire cord (varying from five to seven thirty-seconds of an inch in diameter, according to the work), composed of three mild-steel wires twisted at a certain pitch, that is found to give the best results in practice, at a speed of from 15 to 17 feet per second.

**The Sand-blast.**—In the sand-blast, invented by B. F. Tilghman, of Philadelphia, and first exhibited at the American Institute Fair, New York, in 1871, common sand, powdered quartz, emery, or any sharp cutting material is blown by a jet of air or steam on glass, metal, or other comparatively brittle substance, by which means the latter is cut, drilled, or engraved. To protect those portions of the surface which it is desired shall not be abraded it is only necessary to cover them with a soft or tough material, such as lead, rubber, leather, paper, wax, or rubber-paint. (See description in *App. Cyc. Mech.*; also U. S. report of Vienna Exhibition, 1873, vol. iii. 316.)

A "jet of sand" impelled by steam of moderate pressure, or even by the blast of an ordinary fan, depolishes glass in a few seconds; wood is cut quite rapidly; and metals are given the so-called "frosted" surface with great rapidity. With a jet issuing from under 300 pounds pressure, a hole was cut through a piece of corundum  $1\frac{1}{2}$  inches thick in 25 minutes.

The sand-blast has been applied to the cleaning of metal castings and sheet metal, the graining of zinc plates for lithographic purposes, the frosting of silverware, the cutting of figures on stone and glass, and the cutting of devices on monuments or tombstones, the recutting of files, etc. The time required to sharpen a worn-out 14-inch bastard file is about four minutes. About one pint of sand, passed through a No. 120 sieve, and 4 H.P. of 60-lb. steam are required for the operation. For cleaning castings, compressed air at from 8 to 10 pounds pressure per square inch is employed. Chilled-iron globules instead of quartz or flint-sand are used with good results, both as to speed of working and cost of material, when the operation can be carried on under proper conditions. With the expenditure of 2 H.P. in compressing air, 2 square feet of ordinary scale on the surface of steel and iron plates can be



removed per minute. The surface thus prepared is ready for tinning, galvanizing, plating, bronzing, painting, etc. By continuing the operation the hard skin on the surface of castings, which is so destructive to the cutting edges of milling and other tools, can be removed. Small castings are placed in a sort of slowly rotating barrel, open at one or both ends, through which the blast is directed downward against them as they tumble over and over. No portion of the surface escapes the action of the sand. Plain cored work, such as valve-bodies, can be cleaned perfectly both inside and out. One hundred lbs. of castings can be cleaned in from 10 to 15 minutes with a blast created by 2 H.P. The same weight of small forgings can be scaled in from 20 to 30 minutes. — *Iron Age*, March 8, 1894.

**Polishing and Buffing.**—The type of polishing wheel to be used depends on the class of work. For rough polishing on flat surfaces or where the corners are to be square, a paper or a wooden wheel, faced with leather to which emery or some other abrasive is glued is used. For large flat work, or curved surfaces, bull neck, solid canvas, solid sheepskin, paper or wooden wheels are used. These wheels are also used for such work as stove trimmings, agricultural implements, tools, cast iron and brass parts, etc. Loose or stitched sheepskin, loose or stitched canvas and solid or stitched laminated felt wheels are used for roughing irregular shapes requiring a soft faced wheel which will come in contact with every crevice of the work. Bull neck or wooden wheels are used whenever coloring or finishing is to be done on cast or sheet metal. For work requiring a high polish, as guns, cutlery, etc., sea horse is often employed. The hardness of the wheel depends on the service in which it is to be used, and in the case of linen, canvas, leather, or other built-up wheels on steel centers, is governed by the depth of the flanges clamping the wheel on the arbor; the larger the flanges the harder is the wheel. For most polishing operations, a peripheral speed of the wheel of from 3000 to 6000 ft. per minute is sufficient, and 4000 ft. will serve for most purposes. These are the speeds recommended for muslin, felt or sea horse wheels, although some claims are advanced for speeds as high as 7500 ft., it being stated that lower speeds will scratch the work.

Buffing is the process of obtaining a grainless finish of high luster on plated surfaces. The degree of luster depends on the finish of the surface prior to plating. The work is done on a soft wheel to which a polishing composition has been applied. The polishing composition comprises a heavy grease containing polishing material, as flour-emery, rouge, tripoli, crocus, etc. According to the Chicago Wheel and Mfg. Co. the following compositions are adapted to the different varieties of work. For cutting down and polishing brass, bronze and Britannia metal preparatory to plating, tripoli composition; for smooth surfaces on nickel and brass, crocus composition; for coloring brass, copper, nickel, bronze, German silver, etc., either in solid or plated metal, White Diamond XXX composition; for chased or embossed parts, or for cutting down silver-plated pieces which are afterward to be colored with rouge and alcohol, White Diamond XXXX composition is used; for nickel-plated pieces with a high luster, White Coloring composition, made of Vienna lime is used. Where rapid, sharp, even cutting is desired, emery cake is used. Chandelier rouge is used to produce a deep color on brass and bronze parts.

**Laps and Lapping.**—A series of tests was made by W. A. Knight and A. A. Case (*Jour. A. S. M. E.*, Aug., 1915) to determine the effect on the rate of cutting with different combinations of abrasive lubricant and lap material. The tests were made with hardened steel specimens, and comparative results were obtained with emery, alundum and carborundum used in connection with lard oil, machine oil, gasoline, kerosene, turpentine, alcohol and soda water. The lap materials were cast iron, soft steel and copper. The following conclusions were derived from the investigation: The initial rate of cutting is not greatly different for the different abrasives; carborundum maintains its rate better than either of the others, alundum next, and emery the least; carborundum wears the lap about twice as fast, and alundum  $1\frac{1}{4}$  times as fast as emery; there is no advantage in using an abrasive coarser than No. 150; the rate of cutting is practically proportional to

the pressure; the wear of the laps is in the proportions of cast iron 1.00, steel 1.27, copper 2.62, and this wear is inversely proportional to the hardness by the Brinell test; in general, copper and steel cut faster than cast iron, but where permanence of form is a consideration, cast iron is the superior metal; gasoline and kerosene are the best lubricants to use with cast-iron lap, kerosene, on account of its non-evaporative qualities, being first choice; machine and lard oil are the best lubricants to use with copper or steel lap, but they are least effective on the cast lap; for all laps and all abrasives (of those tested) the cutting is faster with lard oil than with machine oil; alcohol shows no particular merit for the work; turpentine does fairly good work with carborundum, but in general, is not as good as kerosene or gasoline; soda water compares favorably with other lubricants, and on the whole it is slightly better than alcohol or turpentine; wet lapping is from 1.2 to 6 times as fast as dry lapping, depending on the material of the lap and the method of charging.

### EMERY WHEELS AND GRINDSTONES.

*References.* — "American Machinist Grinding Book"; "Grits and Grinds," Norton Company; "Points about Grinding Wheels and their Selection," Brown & Sharpe Mfg. Co.; "Table of Causes of Grinding Wheel Accidents," Independence Inspection Bureau; "Safeguarding Grinding Wheels," Report of Committee of National Machine Tool Builders' Association; Bulletin, "Safeguarding High Speed Grinding Wheels," National Founders' Association; "Operation of Grinding Wheels in Machine Grinding," Geo. I. Alden, *Journal A.S.M.E.*, Jan., 1915.

**Selection of Abrasive Wheels.** (Contributed by the Norton Company, 1915.) — The user of a modern grinding wheel should thoroughly understand these essential features; the definition of grain and grade, the particular conditions of grinding which cause them to vary; the methods of balancing and mounting; truing and dressing; the effect of machine vibration and arc of contact upon grain and grade; the relation of work speed and wheel speed for production and finish; safeguards and dust removal systems.

**Grain.** — Abrasive grains are numbered according to the meshes per lineal inch of the screen through which they have been graded. The numbers used in wheels are 8, 10, 12, 14, 16, 20, 24, 30, 36, 46, 54, 60, 70, 80, 90, 120, 150, 180, 200; when finer than 200, the grains are termed flours, being designated as F, 2F, 3F, 4F, XF, 65C, 65F, F being the coarsest and 65F, the finest. Grits from 12 to 30 are generally used on all heavy work such as snagging; 36 to 80 cover nearly all tool grinding, saw gumming, and other operations where precision in measurement is sought; 90 and finer are used for special work such as grinding steel balls and fine edge work; the flour sizes are used mostly for sharpening and rubbing stones. The number representing the grades of abrasive leave a degree of smoothness of surface which may be compared to that left by files as follows: 8 and 10 represent the cut of a wood rasp; 16, 20, coarse-rough file; 24, 30, ordinary rough file; 36, 40, bastard file; 46, 60, second-cut file; 70, 80, smooth file; 90, 100, superfine file; 120F, 2F, dead-smooth file.

**Grade.** — When the retentive properties of the bond are great, the wheel is called hard; when the grains are easily broken out, it is called soft. A wheel is of the proper grade when its cutting grains are automatically replaced when dulled. Wheels that are too hard glaze. Dressing re-sharpens them, the points of the dresser breaking out and breaking off the cutting grains by percussion.

Soft wheels are used on hard materials, like hardened steel. Here the cutting particles are quickly dulled and must be renewed. On softer materials, like mild steel and wrought iron, harder grades can be used, the grains not dulling so quickly.

The area of surface to be ground in contact with the wheel is of the utmost importance in determining the grade. If it is a point contact like grinding a ball or if an extremely narrow fin is to be removed, we must use a very strongly bonded wheel, on account of the leverage exerted on its grain, which tends to tear out the cutting particles before

**Revolutions per Minute Required for Specified Rates of  
Periphery Speed. Also Stress per Square Inch on  
Norton Wheels at the Specified Rates.**

Diameter, In.	Surface Speeds, Feet per Minute.									
	1000	2000	3000	4000	5000	6000	7000	8000	9000	10000
	Stress per Square Inch, Pounds.									
	3	12	27	48	75	108	147	192	243	300
Revolutions per Minute.										
1	3820	7639	11459	15279	19099	22918	26738	30558	34377	38197
2	1910	3820	5730	7639	9549	11459	13369	15279	17189	19098
3	1273	2546	3820	5093	6366	7639	8913	10186	11459	12732
4	955	1910	2865	3820	4775	5729	6684	7639	8594	9549
5	764	1528	2292	3056	3820	4584	5347	6111	6875	7639
6	637	1273	1910	2546	3183	3820	4456	5093	5729	6366
7	546	1091	1637	2183	2728	3274	3820	4365	4911	5457
8	477	955	1432	1910	2387	2865	3342	3820	4297	4775
10	382	764	1146	1528	1910	2292	2674	3056	3438	3820
12	318	637	955	1273	1591	1910	2228	2546	2865	3183
14	273	546	818	1091	1364	1637	1910	2183	2455	2728
16	239	477	716	955	1194	1432	1671	1910	2148	2387
18	212	424	637	849	1061	1273	1485	1698	1910	2122
20	191	382	573	764	955	1146	1337	1528	1719	1910
22	174	347	521	694	868	1042	1215	1389	1563	1736
24	159	318	477	637	796	955	1114	1273	1432	1591
30	127	255	382	509	637	764	891	1018	1146	1273
36	106	212	318	424	530	637	743	849	955	1061

Table to Figure Surface Speeds of Wheels.  
(Circumferences in Feet, Diameters in Inches.)

Diam. In.	Circumf. Ft.	Diam. In.	Circumf. Ft.	Diam. In.	Circumf. Ft.	Diam. In.	Circumf. Ft.	Diam. In.	Circumf. Ft.	Diam. In.	Circumf. Ft.
1	.262	13	3.403	25	6.546	37	9.687	49	12.828	61	15.970
2	.524	14	3.665	26	6.807	38	9.948	50	13.090	62	16.232
3	.785	15	3.927	27	7.069	39	10.210	51	13.352	63	16.493
4	1.047	16	4.189	28	7.330	40	10.472	52	13.613	64	16.755
5	1.309	17	4.451	29	7.592	41	10.734	53	13.875	65	17.017
6	1.571	18	4.712	30	7.854	42	10.996	54	14.137	66	17.279
7	1.833	19	4.974	31	8.116	43	11.257	55	14.499	67	17.541
8	2.094	20	5.236	32	8.377	44	11.519	56	14.661	68	17.802
9	2.356	21	5.498	33	8.639	45	11.781	57	14.923	69	18.064
10	2.618	22	5.760	34	8.901	46	12.043	58	15.184	70	18.326
11	2.880	23	6.021	35	9.163	47	12.305	59	15.446	71	18.588
12	3.142	24	6.283	36	9.425	48	12.566	60	15.708	72	18.850

To find surface speed, in feet, per minute, of a wheel.

RULE. — Multiply the circumference (see above table) by its revolutions per minute.

Surface speed and diam. of wheel being given, to find number of revolutions of wheel spindle.

RULE. — Multiply surface speed, in feet, per min., by 12 and divide the product by 3.14 times the diam. of the wheel in inches.



they have done their work. If the contact is a broad one, as in grinding a hole, or where the work brings a large part of the surface of the wheel into operation, softer grades must be used, because the depth of cut is so infinitely small that the cutting points in work become dulled quickly and must be renewed, or the wheel glazes and loses its efficiency.

Vibrations in grinding machines cause percussion on the cutting grains, necessitating harder wheels. Wheels mounted on rigid machines can be softer in grade and are much more efficient.

**Speeds of Grinding Wheels.**—The factor of safety in vitrified wheels is proportional to the grade of hardness. Bursting limits are from 12,000 to 25,000 feet per minute, surface speed. Wheels are tested by standard makers at speeds in excess of 9000 feet surface speed per minute. Running speeds in practice are from 4000 to 6000 feet, depending on work, condition of machine, and mounting.

Generally speaking, grinding of tools, reamers, cutters, and surface grinding is done at about 4000 feet, snagging and rough forms of hand grinding at 5000 to 5500 feet, cylindrical grinding, or where the work is rigidly held and where the wheel feed is under control, from 5500 to 6500 feet, and in some instances as high as 7500 feet.

These speeds are all for vitrified wheels. The same speeds will apply to wheels made by the elastic and silicate processes.

**Grain Depth of Cut.**—An analysis of the action of the wheel when in operation shows how theoretical considerations bear out the truth of the empirical rules for the use of grinding wheels in machine grinding. A paper by Geo. I. Alden (*Jour. Am. Soc. M. E.*, Jan., 1915) gives the essential distinction between the radial or real depth at which the wheel cuts and the depth which the abrasive grain in the wheel cuts into the material being ground. The latter depth is termed the "grain depth of cut." This grain depth of cut is the controlling factor in securing the correct working of the wheel. A formula is deduced for computing the grain depth of cut, the application of the analysis is explained and these conclusions reached by Prof. Alden: 1—Other factors remaining constant, increase of work speed increases grain depth of cut, and makes a wheel appear softer. 2—A decrease of wheel speed increases grain depth of cut. 3—Diminishing the diameter of the wheel increases the grain depth of cut; increasing the diameter of the wheel decreases the grain depth of cut. 4—Decreasing the diameter of work increases the grain depth of cut; conversely, increasing the diameter of work decreases the grain depth of cut.

A table of arcs of contact of wheel and work for a limited range of diameters is given, also a table of values of one of the factors in the formula for grain depth of cut.

**Artificial Abrasives.**—Since 1900 artificial abrasives, made in various types of electric furnaces, have been displacing natural abrasives, and they are to-day almost exclusively used. This has been due largely to the ability to control the purity of the raw material and to insure uniformity of cutting action of the finished products. Artificial abrasives are divided into the aluminous group (examples, Alundum, Aloxite and Boro-Carbone), and the silicon carbide group (examples, Crystolon, Carborundum, Carbolite). The abrasive action of the aluminous group is due to the amount of oxide of aluminum, which in these artificial abrasives is in excess of 90%, slightly more than the best corundum and considerably in excess of the alumina content of emery, which rarely exceeds 70%. The aluminous abrasives are characterized by a high degree of toughness and are particularly adapted for grinding materials of high tensile strength such as steel and its alloys. The silicate carbide group is not duplicated by Nature and is somewhat harder and more brittle than the aluminous group. The silicon carbide abrasives are now recognized as standard for grinding materials of low tensile strength such as cast iron, brass pearl, marble, granite and leather.

**Selection of Emery Wheels.**—The Norton Co. (1915) publishes the accompanying table showing the proper grain and grade of wheel for different services. The column headed grain indicates the coarseness of the material composing the wheel, being designated by the number of

meshes per inch of a sieve through which the grains pass. A No. 20 grain will pass through a 20-mesh sieve, but not through a 30-mesh, etc.

## EXPLANATION OF GRADE LETTERS.

Extremely Soft.	Soft.	Medium Soft.	Medium.	Medium Hard.	Hard.	Extremely Hard.
A	E	I	M	Q	U	Y
B	F	J	N	R	W	Z
C	G	K	O	S		
D	H	L	P	T		

**For Grinding High-speed Tool Steel,** The American Emery Wheel Co. recommends a wheel one number coarser and one grade softer than a wheel for grinding carbon steel for the same service.

**Balancing.**—The standard makers of grinding wheels send out wheels balanced within narrow limits, accomplished by inserting lead near the hole. As the wheels wear down it frequently becomes necessary for the user to balance them by removing some of the lead.

**Mounting Grinding Wheels—Safety Devices.**—A code for the mounting of grinding wheels was adopted by 23 manufacturers of grinding wheels in the U. S. and Canada in 1914, and approved by the National Machine Tool Builders' Association. An abstract of the code is given in *Indust. Eng.*, Jan., 1915. The code recognizes as safety devices protection flanges, protection hoods, and protection chucks.

Protection flanges of the double or single concave type, used in conjunction with wheels having double or single convex tapered sides or side are recommended. For double tapered wheels they shall have a taper of not less than  $\frac{3}{4}$  in. per foot for each flange. For single tapered wheels they shall have a taper of not less than  $\frac{3}{4}$  in. per foot. Each flange, whether straight or tapered, shall be recessed at the center at least  $\frac{1}{16}$  in. on the side next to the wheel. All tapered flanges over 10 in. diameter shall be of steel or material of equal strength. Both flanges in contact with the wheels shall be of the same diameter. Wheels should never be run without flanges.

The following table gives the dimensions of flanges to be used where no hoods are provided: *A* = Maximum flat spot at center of flange. *B* = Flat spot at center of wheel. *C* = Minimum diameter of flange. *D* = thickness of flange at bore. *E* = minimum diameter of recess. *F* = Minimum thickness of each flange at bore; all dimensions are in inches.

Dia. of Wheel.	6	8	10	12	14	16	18	20	22	24	26	28	30
<i>A</i>	0	0	0	4	4	4	4	4	4	4	4	4	4
<i>B</i>	1	1	2	4 $\frac{1}{2}$	4 $\frac{1}{2}$	6	6	6	6	6	6	6	6
<i>C</i>	3	5	6	6	8	10	12	14	16	18	20	22	24
<i>D</i>	$\frac{3}{8}$	$\frac{3}{8}$	$\frac{1}{2}$	$\frac{5}{8}$	$\frac{5}{8}$	$\frac{5}{8}$	$\frac{3}{4}$	$\frac{3}{4}$	$\frac{3}{4}$	$\frac{3}{4}$	$\frac{3}{4}$	$\frac{7}{8}$	$\frac{7}{8}$
<i>E</i>	2	3 $\frac{1}{2}$	4	4	5 $\frac{1}{2}$	7	8	9	10 $\frac{1}{2}$	12	13 $\frac{1}{2}$	14 $\frac{1}{2}$	16
<i>F</i>	$\frac{3}{8}$	$\frac{3}{8}$	$\frac{1}{2}$	$\frac{5}{8}$	$\frac{3}{4}$	$\frac{7}{8}$	1	1	1 $\frac{1}{8}$	1 $\frac{1}{8}$	1 $\frac{1}{8}$	1 $\frac{1}{4}$	1 $\frac{1}{4}$

Where protection hoods are provided, straight flanges and straight wheels may be used, the dimensions being as follows, and the reference letters having the same meaning as above:

Dia. of Wheel.	6	8	10	12	14	16	18	20	22	24	26	28	30
<i>C</i>	2	3	3 $\frac{1}{2}$	4	4 $\frac{1}{2}$	5 $\frac{1}{2}$	6	7	7 $\frac{1}{2}$	8	8 $\frac{1}{2}$	10	10
<i>E</i>	1	2	2 $\frac{1}{4}$	2 $\frac{3}{4}$	3	3 $\frac{1}{2}$	4	4 $\frac{1}{2}$	5	5 $\frac{1}{2}$	6	7	7
<i>F</i>	$\frac{3}{8}$	$\frac{3}{8}$	$\frac{3}{8}$	$\frac{1}{2}$	$\frac{1}{2}$	$\frac{1}{2}$	$\frac{5}{8}$	$\frac{5}{8}$	$\frac{5}{8}$	$\frac{5}{8}$	$\frac{5}{8}$	$\frac{3}{4}$	$\frac{3}{4}$

Protection hoods shall be used where practical with wheels not provided with protection flanges, and shall be sufficiently strong to retain all pieces of a broken grinding wheel. They shall conform as nearly as possible to the periphery of the wheel, and leave exposed the

Table for Selection of Grades.

Class of Work.	Alundum.		Crystolon.	
	Grain.	Grade.	Grain.	Grade.
Aluminum castings . . . . .	36 to 46	3 to 4 Elas.	20 to 24	P to R
Brass or bronze castings (large) . . . . .	.....	.....	20 " 24	Q " R
Brass or bronze castings (small) . . . . .	.....	.....	24 " 36	P " R
Cast iron, cylindrical . . . . .	24 comb.	J to K	30 " 46	I " L
Cast iron, surfacing . . . . .	16 to 46	H " K	16 " 30	I " L
Cast iron (small) castings . . . . .	24 " 30	P " R	20 " 30	Q " S
Cast iron (large) castings . . . . .	16 " 20	Q " R	16 " 24	Q " S
Chilled iron castings . . . . .	20 " 30	P " U	20 " 30	Q " R
Dies, chilled iron . . . . .	.....	.....	20 " 30	O " Q
Dies, steel . . . . .	36 to 60	J to L		
Drop forgings . . . . .	20 " 30	P " R		
Hammers, cast steel . . . . .	30	P " Q		
Interior of Automobile Cylinders, (cast iron) . . . . .	.....	.....	36 " 60	I " L
Internal grinding, hardened steel . . . . .	46 to 60	J to M		
Knives (paper), automatic grinding . . . . .	36 " 46	J " K		
Knives (planer), automatic grinding . . . . .	30 " 46	J " K		
Knives (planing mill), hand grind- ing . . . . .	46 " 60	J to M		
Knives, shear and shear blades . . . . .	30 " 60	J " M		
Lathe centers . . . . .	46 " 120	J " M		
Lathe and planer tools . . . . .	} 20 " 24	P Sil.		
		20 " 36	O to P	
Machine-shop use, general . . . . .	20 " 36	O " Q		
Malleable iron castings (large) . . . . .	14 " 20	P " U	16 " 20	R " S
Malleable iron castings (small) . . . . .	20 " 30	P " R	20 " 30	Q " S
Milling cutters, automatic or semi- automatic grinding . . . . .	46 " 60	I " M		
Milling cutters, hand grinding . . . . .	46 " 60	J " M		
Plows (steel), surfacing . . . . .	16 " 24	Q " S		
Pulleys (C.L.), surfacing faces of . . . . .	.....	.....	30 " 36	K " L
Radiators (cast iron), edges of . . . . .	46 to 120	.....	24 " 30	R " S
Reamers, taps, milling cutters, etc., hand grinding . . . . .	46 " 60	K " O		
Reamers, taps, milling cutters, etc., special machines . . . . .	46 " 60	J " M		
Rolls, (cast iron) wet . . . . .	24 " 36	J " M	24 " 46	J " M
Rolls (chilled iron), finishing . . . . .	} 70	1½ " 2 Elas.	70 " 80	1½ to 2 Elas
			80	J
Rolls (chilled iron), roughing. . . . .	.....	.....	30 to 46	2 to 5 Elas.
Rubber . . . . .	30 to 50	J to K	30 " 50	K to M
Saws, gumming and sharpening . . . . .	36 " 50	M " N		
Saws, cold cutting-off . . . . .	60	O " Q		
Steel (soft), cylindrical grinding . . . . .	} 24 comb.	L " P		
		30 to 60	L " O	
Steel (soft), surface grinding . . . . .	16 " 36	H " K		
Steel (hardened), cylindrical grind- ing . . . . .	} 24 comb.	K		
		46 to 60	J to L	
Steel (hardened), surface grinding . . . . .	16 " 46	H " K		
Steel, large castings . . . . .	10 " 20	Q " W		
Steel, small castings . . . . .	20 " 30	P " R		
Steel (manganese), safe work . . . . .	16 " 46	L " P		
Steel (manganese), frogs and switches . . . . .	14 " 16	Q " U		
Structural steel . . . . .	16 " 24	P " R		
Twist drills, hand grinding . . . . .	46 " 60	M		
Twist drills, special machines . . . . .	36 " 60	K to M		
Wrought iron . . . . .	12 " 30	P " U		
Woodworking tools . . . . .	46 " 60	K " M		



least portion of the wheel compatible with the work. A sliding tongue to close the opening in the hood as the wheel is reduced in diameter should be provided. Protruding ends of the wheel arbors and their nuts shall be guarded.

Cups, cylinders and sectional ring wheels shall be either protected with hoods, enclosed in protection chucks, or surrounded with protection bands. Not more than one-quarter of the height of such grinding wheels shall protrude beyond the provided protection.

Grinding wheels shall fit freely on the spindles. Wheel arbor holes shall be made 0.005 in. larger than the machine arbor. The soft metal bushing shall not extend beyond the sides of the wheel at the center. Ends of spindles shall be threaded left and right so that the nuts on both ends will tend to tighten as the spindles revolve. Care should be taken that the spindles are arranged to revolve in the proper direction.

Wheel washers of compressible material, such as blotting paper, rubber or leather, not thicker than 0.025 in., shall be fitted between the wheel and its flanges. It is recommended that the wheel washers be slightly larger than the diameter of the flanges used.

When tightening clamping nuts, care shall be taken to tighten them only enough to hold the wheel firmly. Flanges must be frequently inspected to guard against the use of those which have become bent or out of balance. If a tapered wheel has broken, the flanges must be carefully inspected for truth before using with a new wheel. Clamping nuts shall also be inspected.

#### Minimum Sizes of Machine Spindles in Inches for Various Diameters and Thickness of Grinding Wheels.

Diam. In.	Thickness of Wheel in Inches													
	1/2	3/4	1	1 1/4	1 1/2	1 3/4	2	2 1/4	2 1/2	3	3 1/2	4	4 1/2	5
6	1/2	1/2	1/2	5/8	5/8	3/4	3/4	3/4	3/4	3/4	3/4	1	1	1
7	1/2	5/8	5/8	5/8	3/4	3/4	3/4	3/4	3/4	1	1	1	1	1
8	5/8	5/8	5/8	3/4	3/4	3/4	1	1	1	1	1	1 1/4	1 1/4	1 1/4
9	5/8	3/4	3/4	3/4	3/4	1	1	1	1	1	1 1/4	1 1/4	1 1/4	1 1/4
10	3/4	3/4	3/4	3/4	3/4	1	1	1	1 1/4	1 1/4	1 1/4	1 1/4	1 1/4	1 1/4
12	3/4	3/4	1	1	1	1	1	1	1 1/4	1 1/4	1 1/4	1 1/2	1 1/2	1 1/2
14	7/8	1	1	1 1/4	1 1/4	1 1/4	1 1/4	1 1/4	1 1/4	1 1/2	1 1/2	1 1/2	1 1/2	1 1/2
16	1	1 1/4	1 1/4	1 1/4	1 1/4	1 1/4	1 1/4	1 1/2	1 1/2	1 1/2	1 3/4	1 3/4	1 3/4	1 3/4
18	1 1/4	1 1/4	1 1/4	1 1/4	1 1/2	1 1/2	1 1/2	1 1/2	1 1/2	1 1/2	1 3/4	1 3/4	1 7/8	1 7/8
20		1 1/2	1 1/2	1 1/2	1 1/2	1 1/2	1 1/2	1 1/2	1 1/2	1 1/2	1 3/4	1 7/8	1 7/8	1 7/8
24		1 1/2	1 1/2	1 1/2	1 1/2	1 3/4	1 3/4	1 3/4	1 3/4	1 3/4	2	2	2	2
26			1 1/2	1 1/2	1 1/2	1 3/4	1 3/4	1 3/4	1 3/4	2	2	2 1/4	2 1/4	2 1/4
30				1 1/2	1 3/4	1 3/4	2	2	2	2	2 1/4	2 1/2	2 1/2	2 1/2
36					2	2 1/4	2 1/4	2 1/4	2 1/4	2 1/2	2 3/4	2 3/4	3	3

**Safe Speeds.**—A peripheral speed of 5,000 ft. per min. is recommended as the standard operating speed for vitrified and silicate straight wheels, tapered wheels and shapes other than those known as cup and cylinder wheels, which are used on bench, floor, swing frame and other machines for rough grinding. In no case shall a peripheral speed of 6500 ft. be exceeded.

A peripheral speed of 4500 ft. per min. is recommended as the standard operating speed for vitrified and silicate wheels of the cup and cylinder shape, used on bench, floor, swing frame, and other machines for rough grinding. In no case shall 5500 ft. be exceeded.

For elastic, vulcanite and wheels of other organic bonds, the recommendations of individual wheel manufacturers shall be followed.

For precision grinding an operating peripheral speed of 6500 ft. per min. may be recommended.

If a wheel spindle is driven by a variable-speed motor some device shall be used which will prevent the motor from being run at too high speeds. Cone pulleys determining the speed of a wheel should never be used unless belt-locking devices are provided. Machines should

be provided with a stop or some method of fixing the maximum size of wheel which may be used, at the speed at which the wheel spindle is running.

If wheels become out of balance through wear and cannot be balanced by truing or dressing, they should be removed from the machine.

A wheel used in wet grinding shall not be allowed to stand partly immersed in the water. The water-soaked portion may throw the wheel dangerously out of balance.

Wheel dressers shall be equipped with rigid guards over the tops of the cutters, to protect operator from flying pieces of broken cutters.

Goggles shall be provided for use of grinding wheel operators where there is danger of eye injury.

Work shall not be forced against a cold wheel, but applied gradually, giving the wheel an opportunity to warm and thereby eliminate possible breakage. This applies to starting work in the morning in grinding rooms which are not heated in winter and new wheels which have been stored in a cold place.

#### Grinding as a Substitute for Finish Turning in the Lathe.—

C. H. Norton (*Trans. Am. Soc. M. E.* 1912) recommends the use of the grinding machine as a substitute for the lathe for many forms of cylindrical work. He advocates the elimination of the finishing cut in the lathe, claiming it is more economical to grind to size immediately after the roughing cut than to finish turn and then grind. For this practice, work should not be turned closer than  $\frac{1}{32}$  in. of finish diameter, and coarse feeds, often as coarse as four to the inch, should be used. He cites instances where this method produced pieces in 18 minutes, where the former method of rough and finish turning and then grinding to size required  $28\frac{1}{2}$  minutes. In 1913, the Norton Grinding Co. was using the grinding machine to the exclusion of the lathe for automobile crank-shafts and similar pieces, grinding to size from the rough forging. Instances and methods are shown in *Indust. Eng.*, April, 1913.

**Truing and Dressing.**—(Norton Co., 1915).—A wheel is trued to make it concentric and to give it an accurate surface. Dressing is to sharpen or renew the surface of the wheel when glazed or loaded. Truing on precision grinding machines is performed by a diamond held rigidly in a fixed tool post—never in the hand. There should always be a liberal supply of lubricant or water flowing on the diamond while the truing is being done. In modern practice, truing is for two other purposes, as well as to make the wheel perfectly true: one for sharpening the wheel to obtain production and the other for dulling the wheel to obtain finish. Truing in rough grinding operations is performed by using a dresser, usually an instrument containing steel-cutting wheels, and in practice the rest is adjusted to form a rigid support for the lugs on the dresser, care being taken to see that the dresser is not caught between the wheel and the rest. In using the dresser to sharpen up the surface of the wheel, the rest is left in its usual close adjustment to the wheel. Truing and dressing are two of the most neglected and least understood features in the proper use of grinding wheels.

**Special Wheels.**—Rim wheels and iron-center wheels are specialties that require the maker's guarantee and assignment of speed.

**Safe Speeds for Grindstones and Emery Wheels.**—G. D. Hiscox (*Iron Age*, April 7, 1892), by an application of the formula for centrifugal force in fly-wheels (see Fly-wheels), obtains the figures for strains in grindstones and emery wheels which are given in the tables below. His formulæ are:

Stress per sq. in. of section of a grindstone =  $(0.7071D \times N)^2 \times 0.0000795$   
 Stress per sq. in. of section of an emery wheel =  $(0.7071D \times N)^2 \times 0.00010226$

$D$  = diameter in feet,  $N$  = revolutions per minute.

He takes the weight of sandstone at 0.078 lb. per cubic inch, and that of an emery wheel at 0.1 lb. per cubic inch; Ohio stone weighs about 0.081 lb. and Huron stone about 0.089 lb. per cubic inch. The Ohio stone will bear a speed at the periphery of 2500 to 3000 ft. per min., which latter should never be exceeded. The Huron stone can be trusted up to 4000 ft., when properly clamped between flanges and not excessively wedged in setting. Apart from the speed of grindstones





Morse Tapers.

Taper.	Diam of Plug at Small End.	Diam. at End of Socket.	Standard Plug Depth.	Whole Length of Shank.	Depth of Hole.	End of Socket to Key-way.	Length of Key-way.	Width of Key-way.	Length of Tongue.	Diameter of Tongue.	Thickness of Tongue.	Rad. of Mill for Tongue.	Radius of Tongue.	Shank Depth.	Taper per Foot.	Number of Key.
	D	A	P	B	H	K	L	W	T	d	t	R	a	S		
0	.252	.356	2	211/32	21/32	115/16	9/16	.160	1/4	.235	5/32	5/32	.04	27/32	.625	0
1	.369	.475	21/8	29/16	23/16	21/16	3/4	.213	3/8	.343	13/64	3/16	.05	27/16	.600	1
2	.572	.700	29/16	3 1/8	25/8	21/2	7/8	.26	7/16	17/32	1/4	1/4	.06	215/16	.602	2
3	.778	.938	33/16	3 7/8	3 1/4	31/16	13/16	.322	9/16	23/32	5/16	9/32	.08	311/16	.602	3
4	1.020	1.231	41/16	4 7/8	4 1/8	3 7/8	1 1/4	.478	5/8	31/32	15/32	5/16	.10	4 5/8	.623	4
5	1.475	1.748	53/16	6 1/8	5 1/4	4 15/16	1 1/2	.635	3/4	113/32	5/8	3/8	.12	5 7/8	.630	5
6	2.116	2.494	71/4	8 9/16	7 3/8	7	1 3/4	.76	1 1/8	2	3/4	1/2	.15	8 1/4	.626	6
7	2.75	3.27	10	11 5/8	10 1/8	9 1/2	2 5/8	1.135	1 3/8	2 5/8	1 1/8	3/4	.18	11 1/4	.625	7

Brown & Sharpe Mfg. Co. publishes (*Machy's Data Sheets*) a list of 18 sizes of tapers ranging from 0.20 in. to 3 in. diam. at the small end; taper 0.5 in. to 1 ft., except No. 10, which is 0.5161 in. per ft.

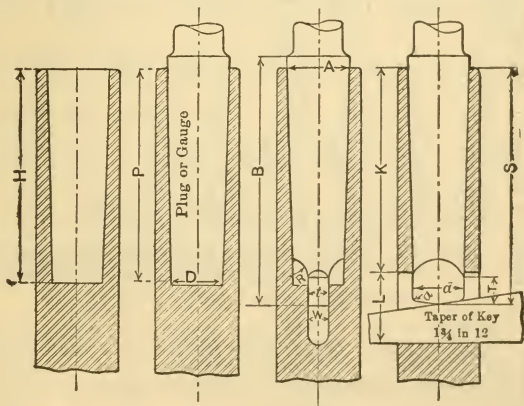

FIG. 216.—Morse Tapers. See table above.

The **Jarno Taper** is 0.05 inch per inch = 0.6 inch per foot. The number of the taper is its diameter in tenths of an inch at the small end, in eighths of an inch at the large end, and the length in halves of an inch. Thus, No. 3 Jarno taper is 1 1/2 inches long, 0.3 inch diameter at the small end and 3/8 inch diameter at the large end.



**Standard Steel Taper-pins.** — The following sizes are made by The Pratt & Whitney Co.: Taper 1/4 inch to the foot.

Number:

0      1      2      3      4      5      6      7      8      9      10  
 Diameter large end:

0.156 0.172 0.193 0.219 0.250 0.289 0.341 0.409 0.492 0.591 0.706

Approximate fractional sizes:

5/32    11/64    3/16    7/32    1/4    19/64    11/32    13/32    1/2    19/32    23/32  
 Lengths from  
 3/4      3/4      3/4      3/4      3/4      3/4      1      1 1/4    1 1/2    1 1/2

To\*  
 1      1 1/4    1 1/2    1 3/4    2      2 1/4    3 1/4    3 3/4    4 1/2    5 1/4    6

Diameter small end of standard taper-pin reamer: †

0.135 0.146 0.162 0.183 0.208 0.240 0.279 0.331 0.398 0.482 0.581

**Dimensions of T-Slots, T-Bolts and T-Nuts.**

(Pratt & Whitney Standard—Dimensions in Inches).

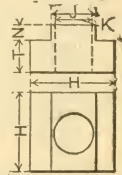
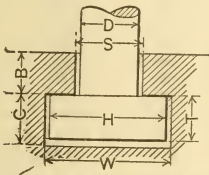

Slot.				Bolt and Nut.					
Width S	W	B † Min.	C	Diam. of Bolt. D	Diam. of Head or Nut. H	Thick-ness of Head or Nut. T	Width of Stem. J	Height of Stem. N	Diam. of Hole. K
1/4	1/2	3/16	5/32	3/16	7/16	1/8	3/16	3/32	1/8
5/16	5/8	3/16	5/32	1/4	9/16	1/8	1/4	1/8	1/8 3/16
3/8	11/16	1/4	7/32	5/16	5/8	3/16	5/16	1/8	3/16 1/4
7/16	13/16	9/32	7/32	3/8	3/4	3/16	3/8	5/32	1/4 5/16
1/2	15/16	5/16	9/32	7/16	7/8	1/4	7/16	3/16	5/16 3/8
5/8	1 3/16	3/8	13/32	9/16	1 1/8	11/32	9/16	3/16	7/16 1/2
3/4	1 5/16	1/2	17/32	11/16	1 1/4	15/32	11/16	1/4	9/16 5/8
7/8	1 5/8	9/16	11/16	3/4	1 1/2	9/16	3/4	5/16	5/8 3/4
1	1 7/8	5/8	13/16	7/8	1 3/4	11/16	7/8	5/16	3/4 7/8

† Maximum thicknesses: Up to 5/8-in. bolts, S + 1/16 in.; 11/16-in. bolt, 1 in.; 3/4-in. bolt, 1 1/16 in.; 7/8-in. bolt, 1 3/16 in.

**PUNCHES AND DIES, PRESSES, ETC.**

**Clearance between Punch and Die.** — For computing the amount of clearance that a die should have, or, in other words, the difference in size between die and punch, the general rule is to make the diameter of die-hole equal to the diameter of the punch, plus 2/10 the thickness of the plate. Or,  $D = d + 0.2t$ , in which  $D$  = diameter of die-hole,  $d$  = diameter of punch, and  $t$  = thickness of plate. For very thick plates some mechanics prefer to make the die-hole a little smaller than called for by the above rule. For ordinary boiler-work the die is made from 1/10 to 3/10 of the thickness of the plate larger than the diameter of the punch; and some boiler-makers advocate making the punch fit

\* Lengths vary by 1/4 inch each size.

† Taken 1/2 inch from extreme end. Each size overlaps smaller one about 1/2 inch.



the die accurately. For punching nuts, the punch fits in the die. (*Am. Mach.*)

The clearance between the punch and die when blanking, perforating and forming flat thin stock of different materials in the power press for light machine parts such as typewriters, adding machines, etc., are shown in the following table compiled by E. Dean (*Am. Mach.*, May 4, 1905). In using the table, the class of work to be done must be considered. For perforating work, the punch is made to the desired size, and the clearance is made on the die. For blanking, the die is of the desired size and the clearance is obtained by making the punch smaller.

#### Punch and Die Clearances for Different Materials and Thicknesses.

Thick-ness of Stock, In.	Clearance for Brass and Soft Steel, In.	Clearance for Medium Rolled Steel, In.	Clearance for Hard Rolled Steel, In.	Thick-ness of Stock, In.	Clearance for Brass and Soft Steel, In.	Clearance for Medium Rolled Steel, In.	Clear-ance for Hard Rolled Steel, In.
0.01	0.0005	0.0006	0.0007	0.11	0.0055	0.0066	0.0077
.02	.001	.0012	.0014	.12	.006	.0072	.0084
.03	.0015	.0018	.0021	.13	.0065	.0078	.0091
.04	.002	.0024	.0028	.14	.007	.0084	.0098
.05	.0025	.003	.0035	.15	.0075	.009	.0105
.06	.003	.0036	.0042	.16	.008	.0096	.0112
.07	.0035	.0042	.0049	.17	.0085	.0102	.0119
.08	.004	.0048	.0056	.18	.009	.0108	.0126
.09	.0045	.0054	.0063	.19	.0095	.0114	.0133
.10	.005	.006	.007	.20	.010	.0120	.0140

**Kennedy's Spiral Punch.** (The Pratt & Whitney Co.) — B. Martell, Chief Surveyor of Lloyd's Register, reported tests of Kennedy's spiral punches in which a  $7/8$ -inch spiral punch penetrated a  $5/8$ -inch plate at a pressure of 22 to 25 tons, while a flat punch required 33 to 35 tons. Steel boiler-plates punched with a flat punch gave an average tensile strength of 58,579 pounds per square inch, and an elongation in two inches across the hole of 5.2 per cent, while plates punched with a spiral punch gave 63,929 pounds, and 10.6 per cent elongation.

The spiral shear form is not recommended for punches for use in metal of a thickness greater than the diameter of the punch. This form is of greatest benefit when the thickness of metal worked is less than two thirds the diameter of punch.

**Size of Blanks used in the Drawing-press.** — Oberlin Smith (*Jour. Frank. Inst.*, Nov. 1886) gives three methods of finding the size of blanks. The first is a tentative method, and consists simply in a series of experiments with various blanks, until the proper one is found. This is for use mainly in complicated cases, and when the cutting portions of the die and punch can be finally sized after the other work is done. The second method is by weighing the sample piece, and then, knowing the weight of the sheet metal per square inch, computing the diameter of a piece having the required area to equal the sample in weight. The third method is by computation, and the formula is  $x = \sqrt{d^2 + 4dh}$  for a sharp-cornered cup, where  $x$  = diameter of blank,  $d$  = diameter of cup,  $h$  = height of cup. For a round-cornered cup where the corner is small, say radius of corner less than  $1/4$  height of cup, the formula is  $x = (\sqrt{d^2 + 4dh}) - r$ , about;  $r$  being the radius of the corner. This is based upon the assumption that the thickness of the metal is not to be altered by the drawing operation.

**Pressure attainable by the Use of the Drop-press.** (R. H. Thurston, *Trans. A. S. M. E.*, v, 53.) — A set of copper cylinders was prepared, of pure Lake Superior copper; they were subjected to the action of presses of different weights and of different heights of fall. Companion specimens of copper were compressed to exactly the same amount, and measures were obtained of the loads producing compression, and of the amount of work done in producing the compression by the drop. Comparing one with the other it was found that the work done with the hammer was 90 per cent. of the work which should have been

done with perfect efficiency. That is to say, the work done in the testing-machine was equal to 90 per cent of that due the weight of the drop falling the given distance.

Formula: Mean pressure in pounds =  $\frac{\text{Weight of drop} \times \text{fall} \times \text{efficiency}}{\text{compression}}$

For pressures per square inch, divide by the mean area opposed to crushing action during the operation.

Similar experiments on Bessemer steel plugs by A. W. Moseley and J. L. Bacon (*Trans. A. S. M. E.*, xxvii, 605) indicated an efficiency for the drop hammer of about 70 per cent.

An extensive series of experiments is reported in *Am. Mach.*, Mar. 10, 1910. These were made by W. T. Sears, and consisted of the compression of lead plugs under a falling weight, ranging from 20 to 200 lb., dropped from heights ranging up to 360 in. The tests showed that after a certain velocity of the falling weight had been attained, the speed had little effect on the compression of the plug. This speed was fixed at 10 ft. per second, but its exact value is uncertain.

**Flow of Metals.** (David Townsend, *Jour. Frank. Inst.*, March, 1878.) — In punching holes  $\frac{7}{16}$ -inch diameter through iron blocks  $1\frac{3}{4}$  inches thick, it was found that the core punched out was only  $1\frac{1}{16}$  inches thick, and its volume was only about 32 per cent of the volume of the hole. Therefore, 68 per cent of the metal displaced by punching the hole flowed into the block itself, increasing its dimensions.

**Fly-wheels for Presses, Punches, Shears, etc.**—The function of the fly-wheel on punching and other machinery in which action is intermittent is to store up energy during that portion of the stroke when no work is being done and to give it out during the period of actual working. The giving up of energy is accompanied by a reduction in the velocity of the fly-wheel.

Notation:

$E$  = total energy in the wheel at maximum velocity, ft.-lb.

$E_1$  = energy given out by the wheel during speed reduction, ft.-lb.

$v_1$  = initial velocity of the center of gravity of fly-wheel rim, ft. per sec.

$v_2$  = velocity of center of gravity of fly-wheel rim at end of period in which energy is given out.

H.P. = horse-power required.

$N$  = strokes of press or shear per min.

$T$  = time required per stroke, secs.

$t$  = time required for actual cutting of metal per stroke, secs.

$w$  = weight of fly-wheel rim, lb.

$d$  = diameter of rim at center of gravity.

$R$  = r.p.m. of fly-wheel at initial velocity.

$c$  and  $c_1$  = constants.

$a$  = width of fly-wheel rim, in.

$b$  = depth of fly-wheel rim, in.

$y$  = ratio of depth to width of rim.

$g$  = acceleration due to gravity = 32.2

Formulae:

$$E = \frac{w v_1^2}{2g} = \frac{w v_1^2}{64.4}$$

$$E_1 = \frac{(v_1^2 - v_2^2) \times W}{64.4}$$

$$w = \frac{E_1 \times 64.4}{v_1^2 - v_2^2}$$

$$v = \frac{2 \pi R N}{60}$$

A simplified method for calculating fly-wheels for punches and shears is given in *Machinery's Handbook*, p. 289. Using the notation as above,

$$H.P. = \frac{E N}{33,000} = \frac{E}{T \times 550}; E_1 = E \left(1 - \frac{t}{T}\right);$$

$$W = \frac{E_1}{c D^2 R^2}; a = \sqrt{\frac{1.22 W}{12 D y}}; b = a y.$$

For cast-iron fly-wheels with maximum stresses of 1000 lb. per sq. in.,  $W = c_1 E_1$ ;  $R = 1940 \div D$ .

VALUES OF  $c$  AND  $c_1$ .

Per Cent Reduction.	2 1/2	5	7 1/2	10	15	20
$c$ .....	0.00000213	0.00000426	0.00000617	0.00000810	0.00001180	0.00001535
$c_1$ .....	0.1250	0.0625	0.0432	0.0328	0.0225	0.0173

For belt-driven machines, the limiting low velocity  $v_2$  is the speed at which the belt will run off the pulley. Wilfred Lewis, *Trans. A. S. M. E.*, vol. vii, shows that this takes place when the slip exceeds 20 per cent of the belt speed. This gives a limiting condition for belt drives of punches and shears of  $W = 180 \left( \frac{E}{v_1^2} \right)$

**FORCING, SHRINKING AND RUNNING FITS.**

**Forcing Fits of Pins and Axles by Hydraulic Pressure.** — A 4-inch axle is turned 0.015 inch diameter larger than the hole into which it is to be fitted. They are pressed on by a pressure of 30 to 35 tons. (Lecture by Coleman Sellers, 1872.)

For forcing the crank-pin into a locomotive driving-wheel, when the pinhole is perfectly true and smooth, the pin should be pressed in with a pressure of 6 tons for every inch of diameter of the wheel fit. When the hole is not perfectly true, which may be the result of shrinking the tire on the wheel center after the hole for the crank-pin has been bored, or if the hole is not perfectly smooth, the pressure may have to be increased to 9 tons for every inch of diameter of the wheel-fit. (*Am. Machinist.*)

**Pressure Table for Mounting Wheels and Crank Pins.**

(Santa Fe R.R. System, 1915.)

Driving Axles.			Eng. Truck Axles.			Crank Pins.			Car Truck Axles.		
Diam. of Wheel Fit, In.	Pressure, Tons. Wheel Centers.		Diam. of Wheel Fit, In.	Pressure, Tons. Wheel Centers.		Diam. of Wheel Fit, In.	Pressure, Tons. Wheel Centers.		Diam. of Wheel Fit, In.	Pressure, Tons. Wheels.	
	Cast Iron.	Steel		Cast Iron.	Steel		Cast Iron.	Steel		Cast Iron.	Steel or Steel Tired*
4 1/2	45- 50	72- 80	3 1/2	20-25	35- 42	3	30	36- 45	4	25-35	30-40
5	50- 55	80- 88	4	25-30	42- 50	4	40	53- 60	5	35-45	45-55
6	60- 65	96-104	4 1/2	30-35	50- 57	5	50	68- 75	5 1/2	40-50	50-60
7	70- 75	112-120	5	35-40	57- 65	6	60	83- 90	6	45-55	50-65
8	80- 85	128-136	5 1/2	40-45	65- 72	7	70	98-105	6 1/2	50-60	55-70
9	90- 95	144-152	6	45-50	72- 80	7 1/2	75	105-113	7	55-65	60-75
10	100-105	160-168	6 1/2	50-55	80- 87	8	80	113-120	<b>CRANK AXLES.</b> All crank discs, 110-150 tons. All center webs 150-200 tons.		
11	110-115	176-184	7	55-60	87- 95	8 1/2	85	120-128			
12	120-125	192-200	7 1/2	60-65	95-102	9	90	128-135			
			8	65-70	102-110	9 1/2	95	135-143			
*Tires on.											

NOTE.—In mounting wheels and crank pins, care should be taken to see that for at least two-thirds of the wheel fit the pressure required shall be between the maximum and minimum limits given in the table, or if only one pressure is shown in the table, the actual pressure required should be as near as possible to that pressure.

In mounting driving wheels with tires on, the maximum pressures given in the tables or even 10 per cent higher pressure than the maximum pressure may be used.

*Shrinkage of Tires.*—Allow 1/64 inch for each 12 in. in diameter.



**Ground Fits for Machine Parts.**—The practice of the Brown & Sharpe Mfg. Co. in tolerances and allowances for ground fits is given in a paper by W. A. Viall (*Trans. A. S. M. E.*, xxxii) from which the table below has been prepared. The limits given can be recommended for satisfactory commercial work in the production of machine parts and may be followed under ordinary conditions. In special cases it may be necessary to vary slightly from the tables.

**Allowances and Tolerances for Fits—Practice of the Brown & Sharpe Mfg. Co.**

Kind of Fit.	Diameter, Up to and Including		
	1/2 In.	1 In.	2 In.
<b>RUNNING FITS</b>			
Ordinary speed.....	-.00025 to -.00075	-.00075 to -.0015	-.0015 to -.0025
High speed, heavy pressure, rocker shafts.....	-.0005 to -.001	-.001 to -.002	-.002 to -.003
<b>SLIDING FITS</b> .....	-.00025 to -.0005	-.0005 to -.001	-.001 to -.002
<b>STANDARD FITS</b> .....	0 to -.00025	0 to -.0005	0 to -.001
<b>DRIVING FITS</b>			
For pieces to be taken apart.....	0 to +.00025	+.00025 to .0005	+ .0005 to +.00075
Ordinary.....	+.0005 to +.001	+.001 to +.002	+.002 to +.003
<b>FORCING FITS</b> .....	+.00075 to +.0015	+.0015 to +.0025	+.0025 to +.004
<b>SHRINKING FITS</b>			
For pieces to take hardened shells 3/8 in. thick or less....	+.00025 to +.0005	+.0005 to +.001	+.001 to +.0015
For pieces to take shells more than 3/8 in. thick.....	+.0005 to +.001	+.001 to +.0025	+.0025 to +.0035
<b>GRINDING LIMITS FOR HOLES</b> .....	0 to +.0005	0 to +.00075	0 to +.001

Kind of Fit.	Diameter Up to and Including		
	3 1/2 In.	6 In.	12 In.
<b>RUNNING FITS</b>			
Ordinary speed.....	-.0025 to -.0035	-.0035 to -.005	.....
High speed, heavy pressure, rocker shafts.....	-.003 to -.0045	-.0045 to -.0065	.....
<b>SLIDING FITS</b> .....	-.002 to -.0035	-.003 to -.005	.....
<b>STANDARD FITS</b> .....	0 to -.0015	0 to -.002	.....
<b>DRIVING FITS</b>			
For pieces to be taken apart.....	+.00075 to +.001	+.001 to +.0015	.....
Ordinary.....	+.003 to +.004	+.004 to +.005	.....
<b>FORCING FITS</b> .....	+.004 to +.006	+.006 to +.009	.....
<b>SHRINKING FITS</b>			
For pieces to take hardened shells 3/8 in. thick or less....	+.0015 to +.002	+.002 to +.003	.....
For pieces to take shells more than 3/8 in. thick.....	+.0035 to +.005	+.005 to +.007	.....
<b>GRINDING LIMITS FOR HOLES</b> .....	0 to +.0015	0 to +.002	0 to +.0025

**Running Fits.**—Wm. Sangster (*Am. Mach.*, July 8, 1909) gives the practice of different manufacturers as follows:

An electric manufacturing Co. allows a clearance of 0.003 to 0.004 in. for shafts 1 1/2 to 2 1/4 in. diam.; 0.003 to 0.006 for 2 1/2 in.; 0.004 to 0.006 for

$2\frac{3}{4}$  to  $3\frac{1}{2}$  ins.; 0.005 to 0.007 in. for 4 and  $4\frac{1}{2}$  ins.; 0.006 to 0.008 in. for 5 ins.; 0.009 to 0.011 in. for 6 ins. Dodge Mfg. Co. allows from  $\frac{1}{64}$  for 1-in. ordinary bearings to a little over  $\frac{1}{32}$  in. for 6-in. Clutch sleeves, 0.008 to 0.015 in.; loose pulleys as close as 0.003 in. in the smaller sizes, and about  $\frac{1}{64}$  in. on a  $2\frac{1}{2}$ -in. hole.

Watt Mining Car Wheel Co. allows  $\frac{1}{16}$  in. for all sizes of wheels, and  $\frac{1}{16}$  in. end play. A large fan-blower concern allows 0.005 to 0.01 in. on fan journals from  $\frac{9}{16}$  to  $2\frac{7}{16}$  ins.

**Limits of Diameters for Fits.** C. W. Hunt Co. (*Am. Mach.*, July 16, 1903.) — For parallel shafts and bushings (shafts changing):  $d$  = diam. in ins.

Shafts: Press fit,  $+0.001 d + (0 \text{ to } 0.001 \text{ in.})$ . Drive fit,  $+0.0005 d + (0. \text{ to } 0.001 \text{ in.})$ .

Shafts: Hand fit,  $+0.001$  to 0.002 in. for shafts 1 to 3 in.; 0.002 to 0.003 in. for 4 to 6 in.; 0.003 to 0.004 in. for 7 to 10 in.

Holes: all fits 0 to  $-0.002$  in. for 1 to 3 in.; 0 to  $-0.003$  in. for 4 to 6 in.; 0 to  $-0.004$  in. for 7 to 10 in.

Parallel journals and bearings (journals changing):

Close fit  $-0.001 d + (0.002 \text{ to } 0.004 \text{ in.})$ ; Free fit  $-0.001 d + (0.007 \text{ to } 0.01 \text{ in.})$ ; Loose fit,  $-0.003 d + (0.02 \text{ to } 0.025)$ . Limits of diameters for taper shaft and bushings (holes changing). Shaft turned to standard taper  $\frac{3}{16}$  in. per ft., large end to nominal size  $\pm 0.001$  in. Holes are reamed until the large end is small by from  $0.001 d + 0.004$  to 0.005 in. for press fit, from  $0.0005 d + 0.001$  in. for drive fit, and from 0 to 0.001 in. for hand fit. In press fits the shaft is pressed into the hole until the true sizes match, or  $\frac{1}{16}$  in. for each  $\frac{1}{1000}$  in. that the hole is small. The above formulæ apply to steel shafts and cast-iron wheels or other members.

**Shaft Allowances for Electrical Machinery.**—The General Electric Co. (1915) gives the following table of allowances for sliding and press fits.

Nominal Diam., In.	Sliding Fit.	Com-mutator and Split Hub.	Press Fit for Armature Spider Solid Steel.	Press Fit for Armature Spider Solid Cast Iron.	Press Fit for Coupling.	Shrink Fit.
2	-0.0015	+0.0005	+0.00075	+0.0015	+0.00175	+0.0025
4	-.002	+ .0005	+ .0015	+ .0025	+ .003	+ .004
8	-.004	+ .001	+ .002	+ .0035	+ .0045	+ .006
12	-.005	+ .001	+ .0025	+ .0045	+ .0055	+ .0075
16	-.0055	+ .001	+ .003	+ .005	+ .006	+ .009
20	-.006	+ .0015	+ .0035	+ .0055	+ .007	+ .010
24	-.007	+ .0015	+ .0035	+ .006	+ .0075	+ .011
28	-.0075	+ .0015	+ .004	+ .0065	+ .0085	+ .012
32	-.008	+ .0015	+ .0045	+ .007	+ .009	+ .0125
36	-.0085	+ .002	+ .0045	+ .0075	+ .0095	+ .0135
40	-.009	+ .002	+ .005	+ .008	+ .010	+ .014
44	-.0095	+ .002	+ .005	+ .0085	+ .0105	+ .0145
48	-.010	+ .002	+ .0055	+ .009	+ .011	+ .015

**Pressure Required for Press Fits.** (*Am. Mach.*, March 7, 1907.)—The following approximate formulæ give the pressures required for press fits of cranks and crank-pins, as used by an engine-building firm.  $P$ =total pressure on ram, tons;  $D$ =diameter inches.

Crank fits up to  $D = 10$ .

$$P = 9.9 D - 14.$$

Crank fits  $D = 12$  to 24.

$$P = 5 D + 40.$$

Straight crank-pins.

$$P = 13 D.$$

Taper crank-pins.

$$P = 14 D - 7.$$

The allowance for cranks and straight pins is 0.0025 inch per inch of diameter. Taper cranks, taper  $\frac{1}{16}$  inch per inch, are fitted on the lathe to within  $\frac{1}{8}$  inch of shoulder and then forced home.

**Stresses due to Force and Shrink Fits.**—S. H. Moore, *Trans. A. S. M. E.*, vol. xxiv, gives the following allowances for different fits:

For shrinkage fits,  $d = (17/16 D + 0.5) \div 1000$ . For forced fits,  $d = (2 D + 0.5) \div 1000$ . For driven fits,  $d = (1/2 D + 0.5) \div 1000$ .  $d$  = allowance or the amount the diameter of the shaft exceeds the diameter of the hole in the ring and  $D$  = nominal diameter of the shaft. A. L. Jenkins, *Eng. News*, Mar. 17, 1910, says the values obtained from the formula for forced fits are about twice as large as those frequently used in practice, and in many cases they lead to excessive stresses in the ring. He calculates from Lamé's formula for hoop stress in a ring subjected to internal pressure the relation between the stress and the allowance for fit, and deduces the following formulæ.

$S_{h_1} = 15,000,000 d \div (k + 0.6)$ ;  $S_{h_2} = 15,000,000 d \div (1 + 0.6/k)$ ; for a cast-iron ring on a steel shaft.

$S_{h_1} = 30,000,000 d \div (1 + k)$ ;  $S_{h_2} = 30,000,000 d \div (1 + 1/K)$ ; for a steel ring on a steel shaft.

$S_{h_1}$  = radial unit pressure between the surfaces;  $S_{h_2}$  = unit tensile or hoop stress in the ring;

$d$  = allowance per inch of diameter,  $K$  a constant whose value depends on  $t$ , the thickness, and  $r$ , the radius of the ring, as follows.

Values of  $t \div r$ ,

0.4 0.5 0.6 0.7 0.8 0.9 1.0 1.25 1.5 1.75 2.0 3.0

Values of  $K$ ,

3.083 2.600 2.282 2.058 1.892 1.766 1.666 1.492 1.380 1.300 1.250 1.133.

The allowances for forced and shrinkage fits should be based on the stresses they produce, as determined by the above formula, and not on the diameter of the shaft.

**Force Required to Start Force and Shrink Fits.** (*Am. Mach.*, Mar. 7, 1907.) — A series of experiments was made at the Alabama Polytechnic Institute on spindles 1 in. diam. pressed or shrunk into cast-iron disks 6 in. diam., 1 1/4 in. thick. The disks were bored and finished with a reamer to 1 in. diam. with an error believed not to exceed 0.00025 in. The shafts were ground to sizes 0.001 to 0.003 in. over 1 in. Some of the spindles were forced into the disks by a testing machine, the others had the disks shrunk on. Some of each sort were tested by pulling the spindle from the disk in the testing machine, others by twisting the disk on the spindle. The force required to start the spindle in the twisting tests was reduced to equivalent force at the circumference of the spindle, for comparison with the tension tests. The results were as follows:  $D$  = diam. of spindle;  $F$  = force in lbs.:

Force Fits, Tension.			Force Fits, Torsion.			Shrink Fits, Tension.			Shrink Fits, Torsion.		
$D$	$F$ , lbs.	Per sq. in.	$D$	$F$ , lbs.	Per sq. in.	$D$	$F$ , lbs.	Per sq. in.	$D$	$F$ , lbs.	Per sq. in.
1.001	1000	318	1.0015	2200	700	1.001	5320	1695	1.001	2200	700
1.0015	2150	685	1.0015	2800	892	1.001	5820	1853	1.0015	7200	2290
1.002	2570	818	1.002	4200	1335	1.002	7500	2385	1.0015	9800	3118
1.0025	4000	1272	1.0025	4600	1465	1.002	8100	2580	1.0025	13800	4395
.....	.....	.....	.....	.....	.....	1.0025	9340	2974	1.003	17000	5410
.....	.....	.....	.....	.....	.....	1.0025	9710	3090	.....	.....	.....



## KEYS.

**Formulae for Flat and Square Keys.**—Great divergence exists in the dimensions of square and flat keys as given by various authorities. The following are the formulae in common use:

*Notation.*— $D$  = diameter of shaft;  $w$  = width of key;  $t$  = thickness of key;  $l$  = length of key, all dimensions being in inches.

E. G. Parkhurst's rule:  $w = 1/8 D$ ;  $t = 1/9 D$ ; taper  $1/8$  in. per ft.

Michigan saw-mill practice:  $w = 1/4 D$ ;  $t = w$ .

J. T. Hawkins's rule:  $w = 1/3 D$ ;  $t = 1/4 D$ .

Machinery's Handbook, rule 1:  $w = 1/4 D$ ;  $t = 1/6 D$ ;  $l = 1.5 D$ .

Machinery's Handbook, rule 2:  $w = 3/16 D + 1/16$ ;  $t = 1/8 D + 1/8$ ;  
 $l = 0.3 D^2 \div t$ .

For splines or feather keys interchange  $w$  and  $t$ .

F. W. Halsey ("Handbook for Machine Designers and Draftsmen") says: The common driven key for securing a crank or gear to a shaft is commonly made with a width of  $1/4 D$  up to about a 4-in. shaft, about  $1\frac{3}{8}$  in. for a 6-in.,  $1\frac{3}{4}$  in. for an 8-in., and  $2\frac{1}{4}$  in. for a 10-in. shaft. The depth should be from  $5/8 w$  to  $3/4 w$ . If the work is at all severe the length should be at least  $1.5 D$ . The taper is commonly  $1/8$  in. per ft.

Unwin ("Elements of Machine Design") gives: Width =  $1/4 D + 1/8$  in. Thickness =  $1/8 D + 1/8$  in. When wheels or pulleys transmitting only a small amount of power are keyed on large shafts, he says, these dimensions are excessive. In that case, if H.P. = horse-power transmitted by the wheel or pulley,  $N$  = r.p.m.,  $P$  = force acting at the circumference, in pounds, and  $R$  = radius of pulley in inches, take

$$D = \sqrt[3]{\frac{100 \text{ H.P.}}{N}} \text{ or } \sqrt{\frac{PR}{630}}$$

John Richards, in an article in *Cassier's Magazine*, writes as follows: There are two kinds or systems of keys, both proper and necessary, but widely different in nature. 1. The common fastening key, usually made in width one fourth of the shaft's diameter, and the depth five eighths to one-third the width. These keys are tapered and fit on all sides, or, as it is commonly described, "bear all over." They perform the double function in most cases of driving or transmitting and fastening the keyed-on member against movement endwise on the shaft. Such keys, when properly made, drive as a strut, diagonally from corner to corner.

2. The other kind or class of keys are not tapered and fit on their sides only, a slight clearance being left on the back to insure against wedge action or radial strain. These keys drive by shearing strain.

For fixed work where there is no sliding movement such keys are commonly made of square section, the sides only being planed, so the depth is more than the width by so much as is cut away in finishing or fitting.

For sliding bearings, as in the case of drilling-machine spindles, the depth should be increased, and in cases where there is heavy strain there should be two keys or feathers instead of one.

The following tables are from proportions adopted in practical use.

Flat keys, as in the first table, are employed for fixed work when the parts are to be held not only against torsional strain, but also against movement endwise; and in case of heavy strain the strut principle being the strongest and most secure against movement when there is strain each way, as in the case of engine cranks and first movers generally. The objections to the system for general use are, straining the work out of truth, the care and expense required in fitting, and destroying the evidence of good or bad fitting of the keyed joint. When a wheel or other part is fastened with a tapering key of this kind there is no means of knowing whether the work is well fitted or not. For this reason such keys are not employed by machine-tool-makers, and in the case of accurate work of any kind, indeed, cannot be, because of the wedging strain, and also the difficulty of inspecting completed work.

## I. DIMENSIONS OF FLAT KEYS, IN INCHES.

Diam. of shaft...	1	1 1/4	1 1/2	1 3/4	2	2 1/2	3	3 1/2	4	5	6	7	8
Breadth of keys...	1/4	5/16	3/8	7/16	1/2	5/8	3/4	7/8	1	1 1/8	1 3/8	1 1/2	1 3/4
Depth of keys...	5/32	3/16	1/4	9/32	5/16	3/8	7/16	1/2	5/8	11/16	13/16	7/8	1

## II. DIMENSIONS OF SQUARE KEYS, IN INCHES.

Diameter of shaft...	1	1 1/4	1 1/2	1 3/4	2	2 1/2	3	3 1/2	4
Breadth of keys...	5/32	7/32	9/32	11/32	13/32	15/32	17/32	9/32	11/16
Depth of keys.....	3/16	1/4	5/16	3/8	7/16	1/2	9/16	5/8	3/4

## III. DIMENSIONS OF SLIDING FEATHER KEYS, IN INCHES.

Diameter of shaft...	1 1/4	1 1/2	1 3/4	2	2 1/4	2 1/2	3	3 1/2	4	4 1/2
Breadth of keys...	1/4	1/4	5/16	5/16	3/8	3/8	1/2	9/16	9/16	5/8
Depth of keys.....	3/8	3/8	7/16	7/16	1/2	1/2	5/8	3/4	3/4	7/8

**Depth of Key Seats.**—The depth of a flat or square key is equally divided between the shaft and the hub. The depth to which a milling cutter is sunk into the shaft in milling a keyway is equal to one-half the depth of the key plus the height of the arc projecting above the intersection of the side of the keyway with the circumference of the shaft. This height can be calculated from the formula

$$h = r - \sqrt{r^2 - (1/2 w)^2}$$

in which  $r$  is the radius of the shaft,  $h$  the height of the arc, and  $w$  the width of the key.

**The Lewis Key.**—The disadvantage of the ordinary flat key is that it must be carefully fitted. A key fitting tight on top and bottom of the keyway drives partly by friction. If fitted only on the sides of the keyway it exerts a prying action on the hub and shaft, and is subjected to severe bending and shearing stresses. Square or flat keys should fit tight on all four sides, but in practice this is prohibitive on account of the expense. To avoid the difficulty inherent in ordinary flat keys, the Lewis key shown in Fig. 217 was devised by Wilfred Lewis. It is subject to compression only, but is expensive to fit.



FIG. 217.

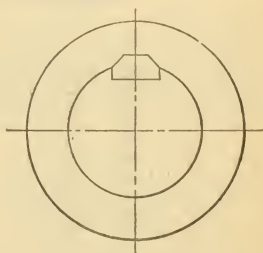
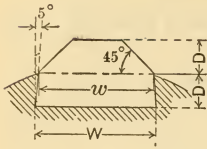

FIG. 218.

**The Barth Key.** (Fred. Oyen, *Am. Mach.*, Nov. 14, 1907, and Feb. 20, 1908.)—The key shown in Fig. 218 was devised by Carl G. Barth to combine the advantages of the Lewis key with those of the ordinary rectangular key. The Barth key is rectangular with one-half of both sides bevelled at 45°. The key does not need to fit tightly, as pressure tends to drive it into its seat. There is no tendency to turn it, and the only stress to which it is subject is compression. This key has been used in many cases as a feather to replace rectangular feather keys which have given trouble. It has found wide application as a feather key in drill sockets and drill shanks, reamers, etc., which are commonly driven with a tang.

Reducing sockets for drill presses are fitted with a Barth key dovetailed inside and a similar keyway on the outside. No. 1 Morse taper shank has a keyway for No. 1 Barth key and fits into a No. 1 reducing socket. No. 2 shank has No. 2 Morse taper and a keyway for No. 2 Barth key, etc. Dimensions of the various sizes of the Barth key are shown in the following table:

**Dimensions of Dovetailed Barth Keys.**



No. of Barth Key.	No. of Morse Taper in Which Used.	$w$ , In.	$W$ , In.	$D$ , In.
1	1	1/8	0.132	5/128
2	2	5/32	0.165	3/64
3	3	3/16	0.199	1/16
4	4	1/4	0.264	5/64
5	5	5/16	0.329	3/23

The Barth key has been adapted to a complete line of standard taper sockets, shanks, driving keys, holdback keys, drifts, adapters, and reducers at the Watertown Arsenal. The standards, which cover both Brown & Sharpe and Morse tapers are given in *Am. Mach.*, Dec. 24, 1914.

**Detrick & Harvey Keys.** (*Am. Mach.*, Feb. 11, 1915.)—The Detrick & Harvey Machine Co., Baltimore, uses square keys of dimensions shown in Fig. 219 and the following table. Although these are smaller than the square key generally used, there is no case known in which one of them has sheared off. The dimension  $C$  is for setting the key, and the dimension  $D$  gives the diameter across the corners of the key. All dimensions are in inches.

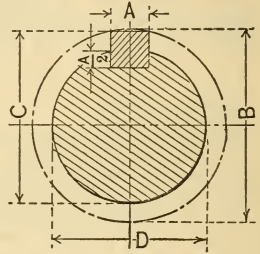

FIG. 219.

**Dimensions of Detrick & Harvey Keys.**

$D$	$A$	$B$	$C$	$D$	$A$	$B$	$C$	$D$	$A$	$B$	$C$
1/2	1/8	0.623	0.555	1 3/8	9/32	1.652	1.501	3 1/2	11/16	4.177	3.808
9/16	1/8	.685	.618	1 1/2	5/16	1.806	1.640	3 3/4	3/4	4.487	4.087
5/8	5/32	.778	.693	1 5/8	5/16	1.931	1.766	4	13/16	4.797	4.364
11/16	5/32	.841	.756	1 3/4	7/16	2.176	1.941	4 1/4	13/16	5.049	4.616
3/4	3/16	.933	.832	1 7/8	7/16	2.302	2.067	4 1/2	13/16	5.303	4.868
13/16	3/16	.996	.895	2	7/16	2.428	2.194	4 3/4	7/8	5.619	5.147
7/8	3/16	1.058	.958	2 1/4	9/16	2.796	2.496	5	7/8	5.864	5.399
15/16	3/16	1.122	1.022	2 1/2	9/16	3.050	2.749	5 1/4	7/8	6.115	5.650
1	1/4	1.242	1.109	2 3/4	5/8	3.361	3.027	5 1/2	15/16	6.422	5.928
1 1/8	1/4	1.368	1.236	3	5/8	3.616	3.280	5 3/4	15/16	6.676	6.180
1 1/4	9/32	1.524	1.375	3 1/4	11/16	3.925	3.556	6	15/16	6.927	6.432

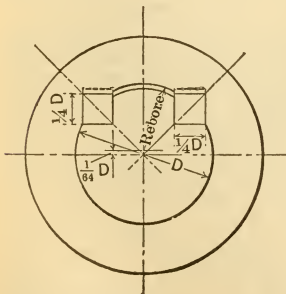

FIG. 220.

**The Kennedy Key.**—The Kennedy key, largely used in rolling mill work, is shown in Fig. 220. In these keys  $w = t = 1/4 D$ . They are tapered 1/8 in. per ft. on top, while the sides are a neat fit. The keys are so set in the shaft that diagonals through them intersect at the axis of the shaft. The hub is bored for a press fit and then is rebored eccentrically about  $1/64 D$  off center. The keyways are cut in the eccentric side. General practice is to use single keys for diameters up to and including 6 in. where the torque is constant and the power transmitted always in one direction. For shafts above 6 in. diameter double keys should be used, and if the torque is intermittent and in alternate directions, double keys should be used down to shaft diameters of 4 in.



**The Nordberg Key.**—The Nordberg Mfg. Co. has adopted for the ends of shafts round keys shown in Fig. 221. The advantages of this key are: No tendency toward deformation; they are a driven fit in the direction of the shear; they are always in true shear and are cheaper than the square key. In manufacturing a hole *A* is drilled in the joint and next a hole *B* as large as the size of the keyway will admit is drilled in the shaft in order to avoid the tendency of the drill used for drilling the keyway to size to crowd into the soft cast iron. In the table the reamer diameters given are of the small end. The taper is 1/16 in. per ft., measured on the diameter.

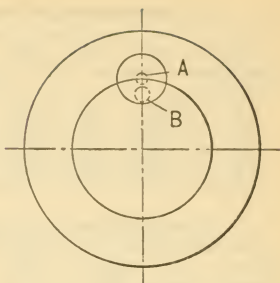
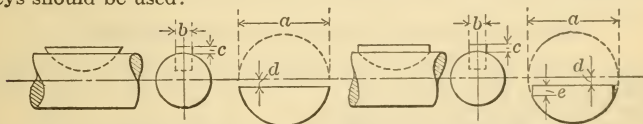

FIG. 221.

**Dimensions of Nordberg Standard Round Keys.**

Diam. of Shaft, In.	Diam. of Reamer In.	Cutting Length of Reamer In.	Diam. of Shaft, In.	Diam. of Reamer In.	Cutting Length of Reamer In.	Diam. of Shaft, In.	Diam. of Reamer In.	Cutting Length of Reamer In.
2 15/16-3	3/4	4 1/4	7	1 5/8	6 7/8 & 8	16	3 1/8	12
3 7/16-3 1/2	7/8	4 1/2	8			17		
3 7/8-4	1	4 7/8	9			18		
4 3/8-4 1/2	1 1/8	5	10	2	10 1/4	19	3 11/16	13
5	1 1/4	4 5/8	11			20		
5 1/2	1 3/8	4 7/8	12			21		
6	1 1/2	6 1/8	13			22		
.....	.....	.....	14	2 9/16	12	23	4 1/4	14 1/4
.....	.....	.....	15			24		

**The Woodruff Key.**—The Woodruff key shown in Fig. 222 is extensively used in machine construction. Dimensions are given in the following table. The key should project above the shaft a distance equal to one-half the thickness. For ordinary practice medium-sized keys should be used:



STANDARD.

FIG. 222.

SPECIAL.

**Dimensions of Woodruff Standard Keys—Inches.**

No.	Diam. of Key, a.	Thick-ness, b.	Depth of Keyway, c.	Center of Stock to Top of Key, d.	No.	Diam. of Key, a.	Thick-ness, b.	Depth of Keyway, c.	Center of Stock to Top of Key, d.	No.	Diam. of Key, a.	Thick-ness, b.	Depth of Keyway, c.	Center of Stock to Top of Key, d.
1	1/2	1/16	1/32	3/64	12	7/8	7/32	7/64	1/16	20	1 1/4	7/32	7/64	5/64
2	1/2	3/32	3/64	3/64	A	7/8	1/4	1/8	1/16	21	1 1/4	1/4	1/8	5/64
3	1/2	1/8	1/16	3/64	13	1	3/16	3/32	1/16	D	1 1/4	5/16	5/32	5/64
4	5/8	3/32	3/64	1/16	14	1	7/32	7/64	1/16	E	1 1/4	3/8	3/16	5/64
5	5/8	1/8	1/16	1/16	15	1	1/4	1/8	1/16	22	1 3/8	1/4	1/8	3/32
6	5/8	5/32	5/64	1/16	B	1	5/16	5/32	1/16	23	1 3/8	5/16	5/32	3/32
7	3/4	1/8	1/16	1/16	16	1 1/8	3/16	3/32	5/64	F	1 3/8	3/8	3/16	3/32
8	3/4	5/32	5/64	1/16	17	1 1/8	7/32	7/64	5/64	24	1 1/2	1/4	1/8	7/64
9	3/4	3/16	3/32	1/16	18	1 1/8	1/4	1/8	5/64	25	1 1/2	5/16	5/32	7/64
10	7/8	5/32	5/64	1/16	C	1 1/8	5/16	5/32	5/64	G	1 1/2	3/8	3/16	7/64
11	7/8	3/16	3/32	1/16	19	1 1/4	3/16	3/32	5/64	.....	.....	.....	.....	.....

## Dimensions of Woodruff Special Keys—Inches.

No.	26	27	28	29	30	31	32	33	34
Dimension									
<i>a</i>	2 1/8	2 1/8	2 1/8	2 1/8	3 1/2	3 1/2	3 1/2	3 1/2	3 1/2
<i>b</i>	3/16	1/4	5/16	3/8	3/8	7/16	1/2	9/16	5/8
<i>c</i>	3/32	1/8	5/32	3/16	3/16	7/32	1/4	9/32	5/16
<i>d</i>	17/32	17/32	17/32	17/32	13/16	13/16	13/16	13/16	13/16
<i>e</i>	3/32	3/32	3/32	3/32	3/16	3/16	3/16	3/16	3/16

## Woodruff Keys Suitable for Different Shaft Diameters.

Shaft Diam.	Key Nos.	Shaft Diam.	Key Nos.	Shaft Diam.	Key Nos.	Shaft Diam.	Key Nos.
5/16-3/8	1	13/16	6, 8	1 3/16	11, 13, 16	1 11/16-1 3/4	18, 21, 24
7/16-1/2	2, 4	7/8-15/16	6, 8, 10	1 1/4-1 5/16	12, 14, 17, 20	1 13/16-2	23, 25
9/16-5/8	3, 5	1	9, 11, 13	1 3/8-1 7/16	14, 17, 20	2 1/16-2 1/2	25
1 1/16-3/4	3, 5, 7	1 1/16-1 1/8	9, 11, 13, 16	1 1/2-1 5/8	15, 18, 21, 24	.....	.....

**Gib Keys.**—"Machinery's Handbook" gives the following formulæ for dimensions of gib keys. (See Fig. 223). All dimensions are in inches.

*D* = diameter of shaft; *w* = width of key; *T* = thickness of key, large end; *S* = safe shearing strength of material in key; *G* = length of gib; *h* = projection of gib above top of key.

*w* = 1/4 *D* up to 6 in.; over 6 in.

*w* = 0.211 *D*.

*T* = 1/6 *D* up to 6 in.; over 6 in. *T* = 1/8 *D*. Minimum value 3/16 in.

*G* = *w*.

Length = length of hub + 1/2 in. Taper 1/8 in. per ft.

Safe twisting moment per in. of length of key = 1/2 *D* × *W* × *S*.

**Keyways for Milling Cutters.**—For keyways for milling cutters see p. 1277.

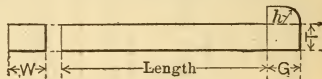

FIG. 223.

## HOLDING-POWER OF KEYS AND SET-SCREWS.

**Tests of the Holding-power of Set-screws in Pulleys.** (G. Lanza, *Trans. A. S. M. E.*, x, 230.)—These tests were made by using a pulley fastened to the shaft by two set-screws with the shaft keyed to the holders; then the load required at the rim of the pulley to cause it to slip was determined, and this being multiplied by the number 6.037 (obtained by adding to the radius of the pulley one-half the diameter of the wire rope, and dividing the sum by twice the radius of the shaft, since there were two set-screws in action at a time) gives the holding-power of the set-screws. The set-screws used were of wrought iron, 5/8 of an inch in diameter, and ten threads to the inch; the shaft used was of steel and rather hard, the set-screws making but little impression upon it. They were set up with a force of 75 pounds at the end of a ten-inch monkey-wrench. The set-screws used were of four kinds, marked respectively A, B, C, and D. The results were as follows:

A, ends perfectly flat, 9/16-in. diam. 1412 to 2294 lbs.; average 2064.  
 B, radius of rounded ends about 1/2-in. 2747 to 3079 lbs.; average 2912.  
 C, radius of rounded ends about 1/4-in. 1902 to 3079 lbs.; average 2573.  
 D, ends cup-shaped and case-hardened 1962 to 2958 lbs.; average 2470.

**REMARKS.**—A. The set-screws were not entirely normal to the shaft; hence they bore less in the earlier trials, before they had become flattened by wear.

B. The ends of these set-screws, after the first two trials, were found to be flattened, the flattened area having a diameter of about 1/4 inch.

C. The ends were found, after the first two trials, to be flattened, as in B.

D. The first test held well because the edges were sharp, then the holding-power fell off till they had become flattened in a manner similar to B, when the holding-power increased again.

**Tests of the Holding-power of Keys.** (Lanza.) — The load was applied as in the tests of set-screws, the shaft being firmly keyed to the holders. The load required at the rim of the pulley to shear the keys was determined, and this, multiplied by a suitable constant, determined in a similar way to that used in the case of set-screws, gives us the shearing strength per square inch of the keys.

The keys tested were of eight kinds, denoted, respectively, by the letters A, B, C, D, E, F, G and H, and the results were as follows: A, B, D, and F, each 4 tests; E, 3 tests; C, G, and H, each 2 tests.

A, Norway iron, 2" × 1/4" × 15/32",	40,184 to	47,760 lbs.;	average, 42,726
B, refined iron, 2" × 1/4" × 15/32",	36,482 to	39,254 lbs.;	average, 38,059
C, tool steel, 1" × 1/4" × 15/32",	91,344 &	100,056 lbs.;	
D, mach'y steel, 2" × 1/4" × 15/32",	64,630 to	70,186 lbs.;	average, 66,875
E, Norway iron, 1 1/3" × 3/8" × 7/16"	36,850 to	37,222 lbs.;	average, 37,036
F, cast-iron, 2" × 1/4" × 15/32",	30,278 to	36,944 lbs.;	average, 33,034
G, cast-iron, 1 1/3" × 3/8" × 7/16",	37,222 &	38,700.	
H, cast-iron, 1" × 1/2" × 7/16",	29,814 &	38,978.	

The first dimension is the length, the second the width and the third the height.

In A and B some crushing took place before shearing. In E, the keys, being only 7/16 inch deep, tipped slightly in the key-way. In H, in the first test, there was a defect in the key-way of the pulley.

## DYNAMOMETERS.

Dynamometers are instruments used for measuring power. They are of several classes, as: 1. Traction dynamometers, used for determining the power required to pull a car or other vehicle, or a plow or harrow. 2. Brake or absorption dynamometers, in which the power of a rotating shaft or wheel is absorbed or converted into heat by the friction of a brake; and 3. Transmission dynamometers, in which the power in a rotating shaft is measured during its transmission through a belt or other connection to another shaft, without being absorbed.

**Traction Dynamometers** generally contain two principal parts: (1) A spring or series of springs, through which the pull is exerted, the extension of the spring measuring the amount of the pulling force; and

(2) a paper-covered drum, rotated either at a uniform speed by clockwork, or at a speed proportional to the speed of the traction, through gearing, on which the extension of the spring is registered by a pencil. From the average height of the diagram drawn by the pencil above the zero-line the average pulling force in pounds is obtained, and

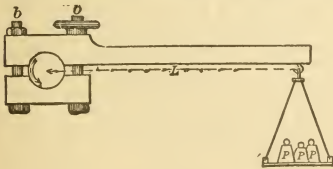

FIG. 224.

this multiplied by the distance traversed, in feet, gives the work done, in foot-pounds. The product divided by the time in minutes and by 33,000 gives the horse-power.

**The Prony brake** is the typical form of absorption dynamometer. (See Fig. 224, from Flather on Dynamometers.)

Primarily this consists of a lever connected to a revolving shaft or pulley in such a manner that the friction induced between the surfaces in contact will tend to rotate the arm in the direction in which the shaft revolves. This rotation is counterbalanced by weights *P*, hung in the scale-pan at the end of the lever. In order to measure the power for a given number of revolutions of pulley, we add weights to the scale-pan



and screw up on bolts *b, b*, until the friction induced balances the weights and the lever is maintained in its horizontal position while the revolutions of the shaft per minute remain constant.

For small powers the beam is generally omitted — the friction being measured by weighting a band or strap thrown over the pulley. Ropes or cords are often used for the same purpose.

Instead of hanging weights in a scale-pan, as in Fig. 224, the friction may be weighed on a platform-scale; in this case, the direction of rotation being the same, the lever-arm will be on the opposite side of the shaft.

In a modification of this brake, the brake-wheel is keyed to the shaft, and its rim is provided with inner flanges which form an annular trough for the retention of water to keep the pulley from heating. A small stream of water constantly discharges into the trough and revolves with the pulley—the centrifugal force of the particles of water overcoming the action of gravity; a waste-pipe with its end flattened is so placed in the trough that it acts as a scoop, and removes all surplus water. The brake consists of a flexible strap to which are fitted blocks of wood forming the rubbing-surface; the ends of the strap are connected by an adjustable bolt-clamp, by means of which any desired tension may be obtained.

The horse-power or work of the shaft is determined from the following:

Let  $W$  = work of shaft, equals power absorbed, per minute;

$P$  = unbalanced pressure or weight in pounds, acting on lever-arm at distance  $L$ ;

$L$  = length of lever-arm in feet from center of shaft;

$V$  = velocity of a point in feet per minute at distance  $L$ , if arm were allowed to rotate at the speed of the shaft;

$N$  = number of revolutions per minute;

H.P. = horse-power.

Then will  $W = PV = 2\pi LNP$ .

Since H.P. =  $PV \div 33,000$ , we have H.P. =  $2\pi LNP \div 33,000$ .

If  $L = 33 \div 2\pi$ , we obtain H.P. =  $NP \div 1000$ .  $33 \div 2\pi$  is practically 5 ft. 3 in., a value often used in practice for the length of arm.

If the rubbing-surface be too small, the resulting friction will show great irregularity — probably on account of insufficient lubrication — the jaws being allowed to seize the pulley, thus producing shocks and sudden vibrations of the lever-arm.

Soft woods, such as bass, plane-tree, beech, poplar, or maple, are all to be preferred to the harder woods for brake-blocks. The rubbing-surface should be well lubricated with a heavy grease.

**The Alden Absorption-dynamometer.** (G. I. Alden, *Trans. A. S. M. E.*, vol. xi, 958; also xii, 700 and xiii, 429.) — This dynamometer is a friction-brake, which is capable in quite moderate sizes of absorbing large powers with unusual steadiness and complete regulation. A smooth cast-iron disk is keyed on the rotating shaft. This is inclosed in a cast-iron shell, formed of two disks and a ring at their circumference, which is free to revolve on the shaft. To the interior of each of the sides of the shell is fitted a copper plate, inclosing between itself and the side a water-tight space. Water under pressure from the city pipes is admitted into each of these spaces, forcing the copper plate against the central disk. The chamber inclosing the disk is filled with oil. To the outer shell is fixed a weighted arm, which resists the tendency of the shell to rotate with the shaft, caused by the friction of the plates against the central disk. Four brakes of this type, 56 in. diam., were used in testing the experimental locomotive at Purdue University (*Trans. A. S. M. E.*, xiii, 429). Each was designed for a maximum moment of 10,500 foot-pounds with a water-pressure of 40 lbs. per sq. in. The area in effective contact with the copper plates on either side is represented by an annular surface having its outer radius equal to 28 ins. and its inner radius equal to 10 ins. The apparent coefficient of friction between the plates and the disk was  $3\frac{1}{2}\%$ .

**Capacity of Friction-brakes.** — W. W. Beaumont (*Proc. Inst. C. E.*, 1889) has deduced a formula by means of which the relative capacity of brakes can be compared, judging from the amount of horse-power ascertained by their use.

If  $W$  = width of rubbing-surface on brake-wheel in inches;  $V$  = vel. of point on circum. of wheel in feet per minute;  $K$  = coefficient; then

$$K = WV \div \text{H.P.}$$

Prof. Flather obtains the values of  $K$  given in the last column of the subjoined table:

Horse-power.	R.P.M. Brake-pulley.	Brake-pulley.		Length of Arm, inches.	Design of Brake.	Value of $K$ .
		Face, in inches.	Diameter, in feet.			
21	150	7	5	33	Royal Ag. Soc., compensating.....	785
19	148.5	7	5	33.38	McLaren, compensating.....	858
20	146	7	5	32.19	McLaren, water-cooled and comp.....	802
40	180	10.5	5	32	Garrett, water-cooled and comp.....	741
33	150	10.5	5	32	Garrett, water-cooled and comp.....	749
150	150	10	9	.....	Schoenheyder, water-cooled.....	282
24	142	12	6	38.31	Balk.....	1385
180	100	24	5	126.1	Gately & Kletsch, water-cooled.....	209
475	76.2	24	7	191	Webber, water-cooled.....	847
125	290	24	4	63	Westinghouse, water-cooled.....	465
250	250					
40	322	13	4	273/4	Westinghouse, water-cooled.....	847
125	290					

The above calculations for eleven brakes give values of  $K$  varying from 84.7 to 1385 for actual horse-powers tested, the average being  $K = 655$ .

Instead of assuming an average coefficient, Prof. Flather proposes the following:

Water-cooled brake, non-compensating,  $K = 400$ ;  $W = 400 \text{ H.P.} \div V$ .

Water-cooled brake, compensating,  $K = 750$ ;  $W = 750 \text{ H.P.} \div V$ .

Non-cooling brake, with or without compensating device,  $K = 900$ ;  $W = 900 \text{ H.P.} \div V$ .

A brake described in *Am. Mach.*, July 27, 1905, had an iron water-cooled drum, 30 in. diam., 20 in. face, with brake blocks of maple attached to an iron strap nearly surrounding the drum. At 250 r.p.m., or a circumferential speed of 1963 ft. per min., the limit of its capacity was about 140 H.P.; above that power the blocks took fire. At 140 H.P. the total surface passing under the brake blocks per minute was 3272 sq. ft., or 23.37 per H.P. This corresponds to a value of  $K = 285$ .

Several forms of Prony brake, including rope and strap brakes, are described by G. E. Quick in *Am. Mach.*, Nov. 17, 1908. Some other forms are shown in *Am. Electrician*, Feb., 1903.

**A 6000 H.P. Hydraulic Absorption Dynamometer**, built by the Westinghouse Machine Co., is described by E. H. Longwell in *Eng. News*, Dec. 30, 1909. It was designed for testing the efficiency of the Melville and McAlpine turbine reduction gear (see page 1095). This dynamometer consists of a rotor mounted on a shaft coupled to the reduction gear and rotating within a closed casing which is prevented from turning by a 6½ ft. lever arm, the end of which transmits pressure through an I-beam lever to a platform scale. The rotor carries several rows of steam turbine vanes and the casing carries corresponding rows of stationary vanes, so arranged as to baffle and agitate the water passing through the brake, which is heated to boiling temperature by the friction. The dynamometer was run for 40 hours continuously, and proved to be a highly accurate instrument.

**Transmission Dynamometers** are of various forms, as the Batchelder dynamometer, in which the power is transmitted through a "train-arm" of bevel gearing, with its modifications, as the one described by the author in *Trans. A. I. M. E.*, viii, 177, and the one described by Samuel Webber in *Trans. A. S. M. E.*, x, 514; belt dynamometers, as the Tatham; the Van Winkle dynamometer, in which the power is transmitted from a revolving shaft to another in line with it, the two almost touching, through the medium of coiled springs fastened to arms or disk keyed to the shafts; the Brackett and the Webb cradle dynamometers, used for measuring the power required to run dynamo-electric machines. Descriptions of the four last named are given in Flather on Dynamometers.

The Kenerson transmission dynamometer is described in *Trans. A. S. M. E.*, 1909. It has the form of a shaft coupling, one part of which con-

tains a cavity filled with oil and covered by a flexible copper diaphragm. The other part, by means of bent levers and a thrust ball-bearing, brings an axial pressure on the diaphragm and on the oil, and the pressure of the oil is measured by a gauge.

Much information on various forms of dynamometers will be found in *Trans. A. S. M. E.*, vols. vii to xv, inclusive, indexed under Dynamometers.

## ICE-MAKING OR REFRIGERATING MACHINES.

**References.**—An elaborate discussion of the thermodynamic theory of the action of the various fluids used in the production of cold was published by M. Ledoux in the *Annales des Mines*, and translated in *Van Nostrand's Magazine* in 1879. This work, revised and additions made in the light of recent experience by Professors Denton, Jacobus, and Riesenberger, was reprinted in 1892. (Van Nostrand's Science Series, No. 46.) The work is largely mathematical, but it also contains much information of immediate practical value, from which some of the matter given below is taken. Other references are Wood's Thermodynamics, Chap. V. and numerous papers by Professors Wood, Denton, Jacobus, and Linde in *Trans. A. S. M. E.*, vols. x to xiv; Johnson's Cyclopædia, article on Refrigerating-machines; and the following books: Siebel's Compend of Mechanical Refrigeration; Modern Refrigerating Machinery, by Lorenz, translated by Pope; Refrigerating Machines, by Gardner T. Voorhees; Refrigeration, by J. Wemyss Anderson, and Refrigeration, Cold Storage and Ice-making, by A. J. Wallis-Taylor. For properties of Ammonia and Sulphur Dioxide, see papers by Professors Wood and Jacobus, *Trans. A. S. M. E.*, vols. x and xii.

For illustrated descriptions of refrigerating-machines, see catalogues of builders, as Frick & Co., Waynesboro, Pa.; De La Vergne Refrigerating-machine Co., New York; Vilter Mfg. Co., Milwaukee; York Mfg., York, Co., Pa.; Henry Vogt Machine Co., Louisville, Ky.; Carbondale Machine Co., Carbondale, Pa.; and others. See also articles in *Ice and Refrigeration*.

**Operations of a Refrigerating-machine.**—Apparatus designed for refrigerating is based upon the following series of operations:

Compress a gas or vapor by means of some external force, then relieve it of its heat so as to diminish its volume; next, cause this compressed gas or vapor to expand so as to produce mechanical work, and thus lower its temperature. The absorption of heat at this stage by the gas, in resuming its original condition, constitutes the refrigerating effect of the apparatus.

A refrigerating-machine is a heat-engine reversed.

From this similarity between heat-motors and freezing-machines it results that all the equations deduced from the mechanical theory of heat to determine the performance of the first, apply equally to the second.

The efficiency depends upon the difference between the extremes of temperature.

The useful effect of a refrigerating-machine depends upon the ratio between the heat-units eliminated and the work expended in compressing and expanding.

This result is independent of the nature of the body employed.

Unlike the heat-motors, the freezing-machine possesses the greatest efficiency when the range of temperature is small, and when the final temperature is elevated.

If the temperatures are the same, there is no theoretical advantage in employing a gas rather than a vapor in order to produce cold.

The choice of the intermediate body would be determined by practical considerations based on the physical characteristics of the body, such as the greater or less facility for manipulating it, the extreme pressures required for the best effects, etc.

Air offers the double advantage that it is everywhere obtainable, and that we can vary at will the higher pressures, independent of the temperature of the refrigerant. But to produce a given useful effect the apparatus must be of larger dimensions than that required by liquefiable vapors.

The maximum pressure is determined by the temperature of the condenser and the nature of the volatile liquid; this pressure is often high.



When a change of volume of a saturated vapor is made under constant pressure, the temperature remains constant. The addition or subtraction of heat, which produces the change of volume, is represented by an increase or a diminution of the quantity of liquid mixed with the vapor.

On the other hand, when vapors, even if saturated, are no longer in contact with their liquids, and receive an addition of heat either through compression by a mechanical force, or from some external source of heat, they comport themselves nearly in the same way as permanent gases, and become superheated.

It results from this property, that refrigerating-machines using a liquefiable gas will afford results differing according to the method of working, and depending upon the state of the gas, whether it remains constantly saturated, or is superheated during a part of the cycle of working.

The temperature of the condenser is determined by local conditions. The interior will exceed by 9° to 18° the temperature of the water furnished to the exterior. This latter will vary from about 52° F., the temperature of water from considerable depth below the surface, to about 95° F., the temperature of surface-water in hot climates. The volatile liquid employed in the machine ought not at this temperature to have a tension above that which can be readily managed by the apparatus.

On the other hand, if the tension of the gas at the minimum temperature is too low, it becomes necessary to give to the compression-cylinder large dimensions, in order that the weight of vapor compressed by a single stroke of the piston shall be sufficient to produce a notably useful effect.

These two conditions, to which may be added others, such as those depending upon the greater or less facility of obtaining the liquid, upon the dangers incurred in its use, either from its inflammability or unhealthfulness, and finally upon its action upon the metals, limit the choice to a small number of substances.

The gases or vapors generally available are: sulphuric ether, sulphurous oxide, ammonia, methylic ether, and carbonic acid.

The following table, derived from Regnault, shows the tensions of the vapors of these substances at temperatures between - 22° and + 104°.

Pressures and Boiling-points of Liquids available for Use in Refrigerating-machines.

Temp. of Ebullition.	Tension of Vapor, in lbs. per sq. in., above Zero.						
	Sulphuric Ether.	Sulphur Dioxide.	Ammonia.	Methylic Ether.	Carbonic Acid.	Pictet Fluid.	Ethyl Chloride
- 40	.....	.....	10.22	.....	.....	.....	.....
- 31	.....	.....	13.23	.....	.....	.....	.....
- 22	.....	5.56	16.95	11.15	.....	.....	2.13
- 13	.....	7.23	21.51	13.85	251.6	.....	2.80
- 4	1.30	9.27	27.04	17.06	292.9	13.5	3.63
5	1.70	11.76	33.67	20.84	340.1	16.2	4.63
14	2.19	14.75	41.58	25.27	393.4	19.3	5.84
23	2.79	18.31	50.91	30.41	453.4	22.9	7.28
32	3.55	22.53	61.85	36.34	520.4	26.9	9.00
41	4.45	27.48	74.55	43.13	594.8	31.2	11.01
50	5.54	33.26	89.21	50.84	676.9	36.2	13.36
59	6.84	39.93	105.99	59.56	766.9	41.7	16.10
68	8.38	47.62	125.08	69.35	864.9	48.1	19.26
77	10.19	56.39	146.64	80.28	971.1	55.6	22.90
86	12.31	66.37	170.83	92.41	1085.6	64.1	27.05
95	14.76	77.64	197.83	.....	1207.9	73.2	31.78
104	17.59	90.32	227.76	.....	1338.2	82.9	37.12

The table shows that the use of ether does not readily lead to the production of low temperatures, because its pressure becomes then very feeble. Ammonia, on the contrary, is well adapted to the production of low temperatures.

Methylic ether yields low temperatures without attaining too great pressures at the temperature of the condenser. Sulphur dioxide readily affords temperatures of  $-14$  to  $-5$ , while its pressure is only 3 to 4 atmospheres at the ordinary temperature of the condenser. These latter substances then lend themselves conveniently for the production of cold by means of mechanical force.

The "Pictet fluid" is a mixture of 97% sulphur dioxide and 3% carbonic acid. At atmospheric pressure it affords a temperature  $14^{\circ}$  lower than sulphur dioxide. (It is not now used — 1910.)

Carbonic acid is in use to a limited extent, but the relatively greater compactness of compressor that it requires, and its inoffensive character, are leading to its recommendation for service on shipboard.

Certain ammonia plants are operated with a surplus of liquid present during compression, so that superheating is prevented. This practice is known as the "cold" or "wet" system of compression.

Ethyl chloride,  $C_2H_5Cl$ , is a colorless gas which at atmospheric pressure condenses to a liquid at  $54.5^{\circ} F$ . The latent heat at  $23^{\circ} F$ . is given at 174 B.T.U. Density of the gas (air=1) = 2.227. Specific heat at constant pressure, 0.274; at constant volume, 0.243.

Nothing definite is known regarding the application of methylic ether or of the petroleum product chymogene in practical refrigerating service. The inflammability of the latter and the cumbrousness of the compressor require are objections to its use.

### PROPERTIES OF SULPHUR DIOXIDE AND AMMONIA GAS.

#### Ledoux's Table for Saturated Sulphur-dioxide Gas.

Heat-units expressed in B.T.U. per pound of sulphur dioxide.

Temperature of Ebullition in deg. F. $t$	Absolute Pressure in lbs. per sq. in. $P \div 144$	Total Heat reckoned from $32^{\circ} F$ . $\lambda$	Heat of Liquid reckoned from $32^{\circ} F$ . $q$	Latent Heat of Evaporation. $r$	Heat Equivalent of External Work. $AP_u$	Internal Latent Heat. $\rho$	Increase of Volume during Evaporation. $u$	Density of Vapor or Weight of 1 cu. ft. $l \div v$
Deg. F.	Lb.	B.T.U.	B.T.U.	B.T.U.	B.T.U.	B.T.U.	Cu. ft.	Lb.
-22	5.56	157.43	-19.56	176.99	13.59	163.39	13.17	0.076
-13	7.23	158.64	-16.30	174.95	13.83	161.12	10.27	.097
-4	9.27	159.84	-13.05	172.89	14.05	158.84	8.12	.123
5	11.76	161.03	-9.79	170.82	14.26	156.56	6.50	.153
14	14.74	162.20	-6.53	168.73	14.46	154.27	5.25	.190
23	18.31	163.36	-3.27	166.63	14.66	151.97	4.29	.232
32	22.53	164.51	0.00	164.51	14.84	149.68	3.54	.282
41	27.48	165.65	3.27	162.38	15.01	147.37	2.93	.340
50	33.25	166.78	6.55	160.23	15.17	145.06	2.45	.407
59	39.93	167.90	9.83	158.07	15.32	142.75	2.07	.483
68	47.61	168.99	13.11	155.89	15.46	140.43	1.75	.570
77	56.39	170.09	16.39	153.70	15.59	138.11	1.49	.669
86	66.36	171.17	19.69	151.49	15.71	135.78	1.27	.780
95	77.64	172.24	22.98	149.26	15.82	133.45	1.09	.906
104	90.31	173.30	26.28	147.02	15.91	131.11	0.91	1.046

E. F. Miller (*Trans. A. S. M. E.*, 1903) reports a series of tests on the pressure of  $SO_2$  at various temperatures, the results agreeing closely with those of Regnault up to the highest figure of the latter,  $149^{\circ} F$ ., 178 lbs. absolute. He gives a table of pressures and temperatures for every degree between  $-40^{\circ}$  and  $217^{\circ}$ . The results obtained at temperatures between  $113^{\circ}$  and  $212^{\circ}$  are as below:

Temp. $^{\circ}F$ .	113	122	131	140	149	158	167	176	194	203	212
Pres. lbs. per sq. in.	104.4	120.1	137.5	156.7	179.5	203.8	230.7	260.5	331.1	371.8	418.

**Properties of Ammonia.**—For a discussion of the properties of ammonia and a bibliography of investigations of ammonia, see Bulletin 66 of the University of Illinois Experiment Station. See also "Properties of Steam and Ammonia," by G. A. Goodenough (John Wiley & Sons, 1915). Prof. Goodenough says that experiments on the properties of ammonia are by no means as complete or as concordant as the experiments on water vapor; hence any formulation for ammonia must be regarded as tentative and subject to revision as further experimental evidence becomes available.

**Properties of Saturated Ammonia.**

(From Goodenough's Tables.)

Absolute Pressure, Lb. per Sq. In.	Temperature, Deg. F.	Volume, Cu. Ft. per Lb.	Weight, Lb. per Cu. Ft.	Total Heat B.T.U.		Latent Heat B.T.U.		Entropy.	
				Of Liquid.	Of Vapor.	Of Vaporization.	Internal.	Of Liquid.	Of Vaporization.
1	-103.7	225.0	0.0044	...	...	644.6	603.0	...	1.8107
5	-62.0	49.3	0.0203	-98.1	519.1	617.2	571.5	-0.2207	1.5523
10	-40.4	25.75	0.0388	-75.7	526.4	602.2	554.6	-0.1661	1.4363
15	-26.4	17.60	0.0568	-61.2	530.9	592.1	543.3	-0.1324	1.3669
20	-15.9	13.45	0.0744	-50.3	534.0	584.3	534.7	-0.1075	1.3168
25	-7.2	10.88	0.0919	-41.3	536.5	577.8	527.4	-0.0876	1.2771
30	+0.1	9.17	0.1090	-33.6	538.5	572.1	521.3	-0.0708	1.2447
35	6.5	7.93	0.1260	-26.9	540.3	567.1	515.8	-0.0561	1.2167
40	12.2	6.99	0.1430	-20.8	541.8	562.6	511.0	-0.0433	1.1924
45	17.4	6.25	0.1598	-15.3	543.1	558.4	506.4	-0.0319	1.1707
50	22.1	5.66	0.1765	-10.3	544.3	554.6	502.3	-0.0216	1.1512
55	26.4	5.18	0.1931	-5.7	545.3	551.1	498.6	-0.0122	1.1338
60	30.5	4.77	0.2096	-1.3	546.3	547.7	495.0	-0.0033	1.1175
65	34.3	4.42	0.2261	+2.7	547.2	544.5	491.6	+0.0051	1.1023
70	37.9	4.12	0.2425	6.6	548.1	541.4	488.4	0.0128	1.0883
75	41.3	3.86	0.2589	10.3	548.8	538.5	485.3	0.0201	1.0751
80	44.5	3.63	0.2753	13.8	549.5	535.8	482.3	0.0271	1.0627
85	47.6	3.43	0.2917	17.2	550.2	533.1	479.5	0.0336	1.0511
90	50.5	3.25	0.3081	20.4	550.9	530.5	476.8	0.0398	1.0400
95	53.3	3.08	0.3246	23.5	551.5	528.0	474.3	0.0458	1.0295
100	56.0	2.93	0.3409	26.5	552.1	525.6	471.8	0.0516	1.0195
110	61.1	2.678	0.3735	32.1	553.1	521.0	467.0	0.0625	1.0006
120	65.8	2.466	0.4056	37.4	554.1	516.7	462.5	0.0725	0.9834
130	70.4	2.283	0.4381	42.5	555.0	512.5	458.2	0.0820	0.9672
140	74.5	2.124	0.4707	47.3	555.9	508.6	454.2	0.0910	0.9521
150	78.5	1.989	0.5028	51.8	556.7	504.8	450.3	0.0993	0.9382
160	82.3	1.868	0.5353	56.2	557.4	501.1	446.6	0.1074	0.9249
170	85.9	1.763	0.5673	60.5	558.1	497.6	443.0	0.1152	0.9121
180	89.4	1.666	0.6000	64.6	558.8	494.1	439.5	0.1226	0.9001
190	92.7	1.580	0.6330	68.6	559.4	490.9	436.2	0.1296	0.8887
200	95.9	1.504	0.665	72.3	560.0	487.6	433.0	0.1363	0.8779
220	101.8	1.370	0.730	79.5	561.0	481.5	426.8	0.1488	0.8578
240	107.4	1.258	0.795	86.4	562.0	475.6	421.0	0.1609	0.8389
260	112.7	1.161	0.861	93.0	562.9	470.0	415.4	0.1722	0.8213
280	117.6	1.079	0.927	99.2	563.8	464.6	410.2	0.1829	0.8048
300	122.4	1.007	0.993	105.3	564.6	459.3	405.0	0.1932	0.7893
350	133.2	0.863	1.159	119.6	566.4	446.8	392.8	0.2171	0.7538
400	142.9	0.752	1.330	132.9	567.9	435.0	381.5	0.2390	0.7220
450	151.8	0.665	1.504	145.6	569.3	423.8	370.8	0.2593	0.6931
500	160.0	0.597	1.675	157.5	570.5	413.0	360.5	0.2786	0.6664
550	167.6	0.539	1.855	169.2	571.7	402.5	350.8	0.2965	0.6419
600	174.7	0.491	2.038	180.4	572.7	392.3	341.3	0.3138	0.6186
650	181.4	0.449	2.227	191.4	573.6	382.2	332.0	0.3307	0.5963
700	187.7	0.414	2.416	202.1	574.4	372.2	322.8	0.3469	0.5758
761.4	195.0	0.376	2.660	215.2	575.4	360.2	311.8	0.3664	0.5503



**Properties of Superheated Ammonia.**

(From Goodenough's Tables.)

$v$  = volume, cu. ft. per lb.,  $n$  = entropy,  $h$  = total heat, B.T.U. per lb.  
Pressure in lb. per sq. in.; temperatures in deg. F.

Pressure, Temp.	15 (-26.4° F.)			20 (-15.9°)			25 (-7.2°)			30 (+0.1°)		
	$v$	$n$	$h$	$v$	$n$	$h$	$v$	$n$	$h$	$v$	$n$	$h$
Sat.	17.6	1.234	530.9	13.4	1.209	534.0	10.9	1.190	536.5	9.17	1.174	538.5
0°	18.9	1.267	545.2	14.0	1.229	542.9	11.1	1.199	540.8	.....	.....	.....
50	21.1	1.320	571.1	15.8	1.284	569.8	12.6	1.256	568.4	10.41	1.233	567.1
100	23.3	1.367	596.4	17.5	1.332	595.5	13.9	1.305	594.5	11.55	1.283	593.7
150	25.5	1.410	621.4	19.1	1.376	620.8	15.2	1.349	620.1	12.65	1.327	619.5
200	27.7	1.449	646.5	21.4	1.431	656.2	16.5	1.389	645.6	13.74	1.367	645.2
240	29.3	1.479	666.9	22.0	1.446	666.4	17.6	1.419	666.0	14.59	1.398	665.7
Pressure, Temp.	40 (12.2°)			50 (22.1°)			60 (30.5°)			70 (37.9°)		
	$v$	$n$	$h$	$v$	$n$	$h$	$v$	$n$	$h$	$v$	$n$	$h$
Sat.	6.99	1.149	541.8	5.67	1.130	544.3	4.77	1.114	546.3	4.12	1.101	548.1
50	7.72	1.195	564.3	6.11	1.165	561.5	5.03	1.139	558.8	4.27	1.117	556.0
100	8.59	1.247	591.8	6.83	1.218	590.0	5.65	1.194	588.2	4.81	1.174	586.5
150	9.44	1.292	618.2	7.51	1.264	617.0	6.22	1.242	615.8	5.31	1.222	614.6
200	10.26	1.333	644.3	8.17	1.306	643.3	6.79	1.283	642.4	5.80	1.265	641.5
300	.....	.....	.....	9.47	1.380	695.7	7.87	1.358	695.1	6.73	1.339	694.6
Pressure, Temp.	80 (44.5°)			90 (50.5°)			100 (56.0°)			120 (65.8°)		
	$v$	$n$	$h$	$v$	$n$	$h$	$v$	$n$	$h$	$v$	$n$	$h$
Sat.	3.63	1.090	549.5	3.25	1.080	550.9	2.94	1.071	552.1	2.47	1.056	554.1
100	4.18	1.156	584.7	3.69	1.140	582.9	3.29	1.125	581.1	2.71	1.099	577.5
150	4.62	1.205	613.4	4.09	1.190	612.1	3.66	1.176	610.8	3.02	1.152	608.4
200	5.04	1.248	640.6	4.47	1.233	639.8	4.01	1.220	638.9	3.31	1.197	637.1
300	5.87	1.323	694.1	5.21	1.309	693.5	4.67	1.297	693.0	3.87	1.275	692.1
340	.....	.....	.....	5.50	1.337	714.9	4.93	1.324	714.6	4.09	1.302	713.9
Pressure, Temp.	140 (74.5°)			160 (82.3°)			200 (95.9°)			240 (107.4°)		
	$v$	$n$	$h$	$v$	$n$	$h$	$v$	$n$	$h$	$v$	$n$	$h$
Sat.	2.12	1.043	555.9	1.87	1.032	557.4	1.50	1.014	560.0	1.26	1.000	562.0
100	2.29	1.076	573.9	1.97	1.056	570.3	1.52	1.020	563.1	.....	.....	.....
150	2.56	1.131	605.9	2.22	1.112	603.5	1.73	1.080	598.4	1.42	1.053	593.5
200	2.82	1.177	635.3	2.44	1.160	633.6	1.92	1.130	630.0	1.57	1.105	626.4
300	3.30	1.256	691.1	2.66	1.202	662.1	2.27	1.212	687.7	1.87	1.189	685.6
360	3.58	1.297	723.9	3.12	1.281	722.9	2.47	1.254	721.0	2.04	1.232	719.3

**Thermal Properties of Liquid Ammonia.**

(From Goodenough's Tables.)

Temp. Deg.F.	Saturation Pressure, Lb. per Sq. In.	Vol. of 1 Lb., Cu. Ft.	Weight of 1 Cu. Ft., Lb.	$144 \times$ $A_{pv}$	Temp. ° F.	Saturation Pressure, Lb. per Sq. In.	Vol. of 1 Lb., Cu. Ft.	Weight of 1 Cu. Ft., Lb.	$144 \times$ $A_{pv}$
-110	0.758	0.02202	45.42	0.003	60	107.7	0.02609	38.33	0.520
-100	1.176	.02220	45.04	.005	70	129.2	.02643	37.85	.632
-80	2.626	.02258	44.28	.011	80	153.9	.02678	37.35	.76
-60	5.358	.02299	43.51	.023	90	181.8	.02714	36.84	.92
-40	10.12	.02342	42.71	.044	100	213.8	.02754	36.32	1.09
-20	17.91	.02388	41.88	.079	120	289.9	.02839	35.23	1.52
0	29.95	.02437	41.04	.135	140	384.4	.02936	34.06	2.09
10	38.02	.02463	40.61	.173	160	500.1	.0305	32.80	2.82
20	47.75	.02490	40.17	.220	180	639.5	.0318	31.5	3.77
30	59.35	.02518	39.72	.247	200	805.6	.0335	29.9	4.99
40	73.03	.02547	39.27	.344	250	1357.4	.0404	24.8	10.2
50	89.1	.02577	38.81	.425	273.2	1690.0	.0678	14.75	21.2

$A$  = reciprocal of Joule's equivalent =  $1/777.6$ ;  $p$  = pressure, lb. per sq. in.;  $v$  = vol. of 1 lb., cu ft.

**Solubility of Ammonia.** (Siebel.)—One pound of water will dissolve the following weights of ammonia at the pressures and temperatures F° stated.

Abs. Press. per sq. in.	32°	68°	104°	Abs. Press. per sq. in.	32°	68°	104°	Abs. Press. per sq. in.	32°	68°	104°
lb.	lb.	lb.	lb.	lb.	lb.	lb.	lb.	lb.	lb.	lb.	lb.
14.67	0.899	0.518	0.338	21.23	1.236	0.651	0.425	27.99	1.603	0.780	0.486
15.44	0.937	0.635	0.349	22.19	1.283	0.669	0.434	28.95	1.656	0.801	0.493
16.41	0.980	0.556	0.363	23.16	1.330	0.685	0.445	30.88	1.758	0.842	0.511
17.37	1.029	0.574	0.378	24.13	1.388	0.704	0.454	32.81	1.861	0.881	0.530
18.34	1.077	0.594	0.391	25.09	1.442	0.722	0.463	34.74	1.966	0.919	0.547
19.30	1.126	0.613	0.404	26.06	1.496	0.741	0.472	36.67	2.070	0.955	0.565
20.27	1.177	0.632	0.414	27.02	1.549	0.761	0.479	38.60	.....	0.992	0.579

**Strength of Aqua Ammonia at 60° F.**

% NH <sub>3</sub> by wt.	2	4	6	8	10	12	14	16	18
Sp. gr.	0.986	.979	.972	.966	.960	.953	.945	.938	.931
% NH <sub>3</sub>	20	22	24	26	28	30	32	34	36
Sp. gr.	0.925	.919	.913	.907	.902	.897	.892	.888	.884

**Properties of Saturated Vapors.**—The figures in the following table are given by Lorenz, on the authority of Mollier and of Zeuner.

° F.	Heat of Vaporization, B.T.U. per lb.			Heat of Liquid, B.T.U. per lb.			Absolute Pressure, lbs. per sq. in.			Volume of 1 lb., cubic feet.		
	NH <sub>3</sub>	CO <sub>2</sub>	SO <sub>2</sub>	NH <sub>3</sub>	CO <sub>2</sub>	SO <sub>2</sub>	NH <sub>3</sub>	CO <sub>2</sub>	SO <sub>2</sub>	NH <sub>3</sub>	CO <sub>2</sub>	SO <sub>2</sub>
- 4°	589.0	117.6	171.0	-31.21	-17.19	-11.16	27.1	288.7	9.27	10.33	0.312	8.06
+14°	580.0	110.7	168.2	-15.89	- 9.00	- 5.69	41.5	385.4	14.75	6.92	0.229	5.27
32°	569.0	99.8	164.2	0	0	0	61.9	503.5	22.53	4.77	0.167	3.59
50°	555.5	86.0	158.9	16.51	10.28	5.90	89.1	650.1	33.26	3.38	0.120	2.44
68°	539.9	66.5	152.5	33.58	23.08	12.03	125.0	826.4	47.61	2.47	0.083	1.71
86°	521.4	27.1	144.8	51.28	45.45	18.34	170.8	1040.	66.36	1.83	0.048	1.22
104°	500.4	.....	135.9	69.58	.....	24.88	227.7	.....	90.30	1.39	.....	0.88

The figures for CO<sub>2</sub> in the above table differ widely from those of Regnault, and are no doubt more reliable.

**Heat Generated by Absorption of Ammonia.** (Berthelot, from Siebel.)—Heat developed when a solution of 1 lb. NH<sub>3</sub> in *n* lbs. water is diluted with a great amount of water =  $Q = 142/n$  B.T.U. Assuming 925 B.T.U. to be developed when 1 lb. NH<sub>3</sub> is absorbed by a great deal (say 200 lbs.) of water, the heat developed in making solutions of different strengths (1 lb. NH<sub>3</sub> to *n* lbs. water) =  $Q_1 = 925 - 142/n$  B.T.U. Heat developed when *b* lbs. NH<sub>3</sub> is added to a solution of 1 lb. NH<sub>3</sub> + *n* lbs. water =  $Q_3 = 925b - 142(2b + b^2)/n$  B.T.U.

Let the weak liquor enter the absorber with a strength of 10%, = 1 lb. NH<sub>3</sub> + 9 lbs. water, and the strong liquor leave the absorber with a strength of 25%, = 3 lbs. NH<sub>3</sub> + 9 lbs. water,  $b = 2, n = 9; Q_3 = 925 \times 2 - 142(4 + 4)/9 = 1724$  B.T.U. Hence by dissolving 2 lbs. of ammonia gas or vapor in a solution of 1 lb. ammonia in 9 lbs. water we obtain 12 lbs. of a 25% solution, and the heat generated is 1724 B.T.U.

**Cooling Effect, Compressor Volume, and Power Required.**—The following table gives the theoretical results computed on the basis of a temperature in the evaporator of 14° F. and in the condenser of 68° F.; in the first three columns of figures the cooling agent is supposed to flow through the regulating valve with this latter temperature; in the last three it is previously cooled to 50° F.

From the stroke-volume per 100,000 B.T.U. the minimum theoretical horse-power is obtained as follows: Adiabatic compression is assumed for the ratio of the absolute condenser pressure to that of the vaporizer, and the mean pressure through the stroke thus found, in lbs. per sq. ft.; multiplying this by the stroke volume per hour and dividing by 1,980,000 gives the net horse-power. The ratio of the mean effective pressure, M.P., to the vaporizer pressure, V.P., for different ratios of condenser pressure, C.P., to vaporizer pressure is given on the next page.

## Cooling Effect, Compressor Volume, and Power Required, with Different Cooling Agents. (Lorenz.)

Cooling Agent.	NH <sub>3</sub>	CO <sub>2</sub>	SO <sub>2</sub>	NH <sub>3</sub>	CO <sub>2</sub>	SO <sub>2</sub>
1. Temp. in front of regulating valve.....	68	68	68	50	50	50
2. Vaporizer pressure, lbs. per sq. in.....	41.5	385.4	14.75	41.5	385.4	14.75
3. Condenser pressure, lbs. per sq. in.....	125.0	826.4	47.61	125.0	826.4	47.61
4. Heat of evaporation, B.T.U. per lb.....	580.2	110.7	168.2	580.2	110.7	168.2
5. Heat imparted to the liquid	49.47	32.08	17.72	32.4	19.28	11.59
6. Cold produced per lb. B.T.U	530.73	78.62	150.48	547.8	91.42	156.61
7. Cooling agent circulated for yield of 100,000 B.T.U. per hour, lbs.....	188.4	1272.	664.3	182.5	1094.	638.5
8. Stroke volume for 100,000 B.T.U. per hour, cu. ft.....	1,300	292	3,507	1,264	242	3,365
9. Minimum H.P. per 100,000 B.T.U. per hour.....	4.98	4.98	4.98	4.98	4.98	4.98
10. Ratio Heat of evap. ÷ cold produced.....	1.093	1.408	1.118	1.059	1.211	1.074
11. Ratio total work to minimum	1.175	1.513	1.202	1.138	1.302	1.155
12. Total I.H.P. per 100,000 B.T.U. per hour.....	5.85	7.53	5.99	5.67	6.48	5.75
13. Cooling effect per I.H.P. hr..	17,100	13,300	16,700	17,600	15,400	17,400

## RATIOS OF CONDENSER PRESSURE, C. P., AND MEAN EFFECTIVE PRESSURE, M. P., TO VAPORIZER PRESSURE, V. P.

VP + CP	VP ÷ MP	VP + CP	VP ÷ MP	VP + CP	VP ÷ MP	VP + CP	VP ÷ MP	VP + CP	VP ÷ MP	VP + CP	VP ÷ MP
1.0	0.	2.0	0.752	3.0	1.249	4.0	1.684	5.0	1.947	6.0	2.216
1.2	0.186	2.2	0.865	3.2	1.344	4.2	1.711	5.2	2.006	7.0	2.454
1.4	0.350	2.4	0.970	3.4	1.414	4.4	1.766	5.4	2.062	8.0	2.666
1.6	0.487	2.6	1.070	3.6	1.491	4.6	1.829	5.6	2.116	9.0	2.858
1.8	0.630	2.8	1.163	3.8	1.564	4.8	1.891	5.8	2.168	10.0	3.036

The minimum theoretical horse-power thus obtained is increased by the ratio of the heat of evaporation to the available cooling action (line 4 ÷ line 6, = line 10 of the table) and by an allowance for the resistance of the valves taken at 7.5% to obtain the total H.P. given in the table.

To the theoretical horse-power given in line 12 Lorenz makes numerous additions, viz.: friction of the compression and driving machine 0.90, 1.10, 0.90, 0.85, 0.95, 0.85 respectively for the six columns in the table; also H.P. for stirring 0.3; for cooling-water pumps, 0.45; for brine pumps, 2.2; for transmission of power, 0.6, making the total H.P. for the six cases 10.30, 12.18, 10.44, 10.07, 10.98, 10.15. He also makes deductions from the theoretical generation of cold of 100,000 B.T.U. per hour, for a brewery cooling installation, for irregularities of valves, etc., for NH<sub>3</sub> and SO<sub>2</sub> machines 10% and for CO<sub>2</sub> machines 5%; for cooling loss through stirring 765 B.T.U., through brine pumps 5610 B.T.U., and through radiation 4500 B.T.U., making the net cooling for NH<sub>3</sub> and SO<sub>2</sub> machines 79,125 B.T.U. and for CO<sub>2</sub> machines 84,125 B.T.U., and the cold generated per effective H.P. in the six cases, 7682, 6908, 7578, 7848, 7662, and 7796 B.T.U.

The figures given in the tables are not to be considered as holding generally or extended to other condenser and evaporator temperatures. Each change of condition requires a separate calculation. The final results indicate that for the various cooling systems no appreciable difference exists in the work required for the same amount of cold delivered at the place where it is to be applied.



**Properties of Brine Used to Absorb Refrigerating Effect of Ammonia.** (J. E. Denton, *Trans. A. S. M. E.*, x, 799).—A solution of Liverpool salt in well-water having a specific gravity of 1.17, or a weight per cubic foot of 73 lbs., will not sensibly thicken or congeal at 0° F.

The mean specific heat between 39° and 16° Fahr. was found by Denton to be 0.805. Brine of the same specific gravity has a specific heat of 0.805 at 65° Fahr., according to Naumann.

Naumann's values (*Lehr-und Handbuch der Thermochemie*, 1882) are:  
 Specific heat..... 0.791 0.805\* 0.863 0.895 0.941 0.962 0.978  
 Specific gravity.... 1.187 1.170 1.103 1.072 1.044 1.023 1.012

**Properties of Salt Brine (Carbondale Calcium Co.)**

Deg. Baumé 60° F.....	1	5	10	15	19	23
Deg. Salinometer 60° F.....	4	20	40	60	80	100
Sp. gravity 60° F.....	1.007	1.037	1.073	1.115	1.150	1.191
Per cent of salt, by wt....	1	5	10	15	20	25
Wt. of 1 gallon, lbs.....	8.40	8.65	8.95	9.30	9.60	9.94
Wt. of 1 cu. ft., lbs.....	62.8	64.7	66.95	69.57	71.76	74.26
Freezing point ° F.....	31.8	25.4	18.6	12.2	6.86	1.00
Specific heat.....	0.992	0.960	0.892	0.855	0.829	0.783

**Chloride of Calcium** solution is commonly used instead of brine. According to Naumann, a solution of 1.0255 sp. gr. has a specific heat of 0.957. A solution of 1.163 sp. gr. in the test reported in *Eng'g*, July 22, 1887, gave a specific heat of 0.827.

H. C. Dickinson (*Science*, April 23, 1909) gives the following values of the specific heat of solutions of chemically pure calcium chloride.

Density	Specific Heat	Temperature, C.
1.07.....	0.869 + 0.00057 t	(- 5° to + 15°)
1.14.....	0.773 + 0.00064 t	(- 10° to + 20°)
1.20.....	0.710 + 0.00064 t	(- 20° to + 20°)
1.26.....	0.662 + 0.00064 t	(- 25° to + 20°)

The advantages of chloride of calcium solution are its lower freezing point and that it has little or no corrosive action on iron and brass. Calcium chloride is sold in the fused or granulated state, in steel drums, containing about 75% anhydrous chloride and 25% water, or in solution containing 40 to 50% anhydrous chloride, in tank cars. The following data are taken from the catalogue of the Carbondale Calcium Co.

**PROPERTIES OF "SOLVAY" CALCIUM CHLORIDE SOLUTION.**

Deg. Baumé, 60° F.	Spec. Grav., 60° F.	Per cent, CaCl.	Freezes at Deg. F.	Deg. Baumé, 60° F.	Spec. Grav., 60° F.	Per cent, CaCl.	Freezes at Deg. F.	Deg. Baumé, 60° F.	Spec. Grav., 60° F.	Per cent, CaCl.	Freezes at Deg. F.
1.	1.007	1	+31.10	21	1.169	19	+ 1.76	32	1.283	30	-54.40
5.5	1.041	5	27.68	22	1.179	20	- 1.48	35	1.316	33	-25.24
11	1.085	10	22.38	23	1.189	21	- 4.90	35.5	1.327	34	- 9.76
17	1.131	15	12.20	26	1.219	24	-17.14	36.5	1.338	35	+ 2.84
20	1.159	18	4.64	29	1.250	27	-32.62	37.5	1.349	36	14.36

Quantity of 75% calcium chloride required to make solutions of different specific gravities and freezing points.

Sp. gravity.....	1.250	1.225	1.200	1.175	1.150	1.125	1.100
Lbs. per cu ft. solution.....	28.06	25.06	22.05	19.15	16.26	13.47	10.70
Lbs. per gallon.....	3.76	3.36	2.95	2.56	2.18	1.80	1.43
Freezing point ° F. .	-32.6	-19.5	-8.7	Zero	+7.5	+13.3	+18.5

**Boiling points of calcium chloride solutions:**

Sp. Gr. at 59° F....	1.104	1.185	1.238	1.341	1.383	solid at 59°.	
Boiling point ° F....	215.6	221.0	230.0	240.8	248.0	266.0	282.2 306.5
Sp.gr.atboilingpoint	1.085	1.119	1.209	1.308	1.365	1.452	1.526 1.619

\* Interpolated.

**"Ice-melting Effect."**—It is agreed that the term "ice-melting effect" means the cold produced in an insulated bath of brine, on the assumption that each 144 B.T.U. represents one pound of ice, this being the latent heat of fusion of ice, or the heat required to melt a pound of ice at 32° to water at the same temperature. The performance of a machine, expressed in pounds or tons of "ice-melting capacity," does not mean that the refrigerating-machine would make the same amount of actual ice, but that the cold produced is equivalent to the effect of the melting of ice at 32° to water of that temperature.

In making artificial ice the water frozen is generally about 70° F. when submitted to the refrigerating effect of a machine; second, the ice is chilled from 12° to 20° below its freezing-point; third, there is a dissipation of cold, from the exposure of the brine tank and the manipulation of the ice-cans: therefore the weight of actual ice made, multiplied by its latent heat of fusion, 144 thermal units, represents only about three-fourths of the cold produced in the brine by the refrigerating fluid per I.H.P. of the engine driving the compressing-pumps. Again, there is considerable fuel consumed to operate the brine-circulating pump, the condensing-water and feed-pumps, and to reboil, or purify, the condensed steam from which the ice is frozen. This fuel, together with that wasted in leakage and drip water, amounts to about one-half that required to drive the main steam-engine. Hence the pounds of actual ice manufactured from distilled water is just about half the equivalent of the refrigerating effect produced in the brine per indicated horse-power of the steam-cylinders.

When ice is made directly from natural water by means of the "plate system," about half of the fuel, used with distilled water, is saved by avoiding the reboiling, and using steam expansively in a compound engine.

**Ether-machines**, used in India, are said to have produced about 6 lbs. of actual ice per pound of fuel consumed.

The ether machine is obsolete, because the density of the vapor of ether, at the necessary working-pressure, requires that the compressing-cylinder shall be about 6 times larger than for sulphur dioxide, and 17 times larger than for ammonia.

**Air-machines** require about 1.2 times greater capacity of compressing cylinder, and are, as a whole, more cumbersome than ether machines, but they remain in use on shipboard. In using air the expansion must take place in a cylinder doing work, instead of through a simple expansion-cock which is used with vapor machines. The work done in the expansion-cylinder is utilized in assisting the compressor.

*The Allen Dense Air Machine* takes for compression air of considerable pressure which is contained in the machine and in a system of pipes. The air at 60 or 70 lbs. pressure is compressed to 210 or 240 lbs. It is then passed through a coil immersed in circulating water and cooled to nearly the temperature of the water. It then passes into an expander, which is, in construction, a common form of steam-engine with a cut-off valve. This engine takes out of the air a quantity of heat equivalent to the work done by the air while expanding, to the original pressure of 60 or 70 lbs., and reduces its temperature to about 90° to 120° F. below the temperature of the cooling water supply. The return stroke of the piston pushes the air out through insulated pipes to the places that are to be refrigerated, from which it is returned to the compressor.

The air pushed out by the expander is commonly about 35 to 55 below zero F. In arrangements where not all the cold is taken out of the air by the refrigerating apparatus, the highly compressed air after cooling in the coil is further cooled by being brought in surface contact with the returning and still cold air, before entering the expander. By this means temperatures of 70 to 90 below zero may be obtained.

The refrigerating effect in B.T.U. per minute is: Lbs. of air handled per min.  $\times$  0.2375  $\times$  difference of temperature of air passing out of expander and of that returning to the machine.

**Carbon-dioxide Machines** are in extensive use on shipboard. S. H. Bunnell (*Eng. News*, April 9, 1903) says there are over 1500 CO<sub>2</sub> plants on shipboard. He describes a large duplex CO<sub>2</sub> compressor built by the Brown-Cochrane Co., Lorain, O. Tests of CO<sub>2</sub> machines by a committee of the Danish Agricultural Society were reported in 1899, in "Ice and

Cold Storage," of London. Carbon-dioxide machines are built also by Kroeschel Bros., Chicago.

**Methyl-Chloride** machines are made by Railway and Stationary Refrigerating Co., New York City. The compressor is a rotary pump. When driven by an electric motor the complete apparatus is very compact, and is therefore suitable for refrigerator cars or other places where space is restricted.

**Sulphur-Dioxide Machines.**—Results of theoretical calculations are given in a table by Ledoux showing an ice-melting capacity per horse-power ranging from 134 to 63 lbs., and per pound of coal ranging from 44.7 to 21.1 lbs., as the temperature corresponding to the pressure of the vapor in the condenser rises from 59° to 104° F. The theoretical results do not represent the actual.

Prof. Denton says concerning Ledoux's theoretical results: The figures given are higher than those obtained in practice, because the effect of superheating of the gas during admission to the cylinder is not considered. This superheating may cause an increase of work of about 25%. There are other losses due to superheating the gas at the brine-tank, and in the pipe leading from the brine-tank to the compressor, so that in actual practice a sulphur-dioxide machine, working under the conditions of an absolute pressure in the condenser of 56 lbs. per sq. in. and the corresponding temperature of 77° F., will give about 22 lbs. of ice-melting capacity per pound of coal, which is about 60% of the theoretical amount neglecting friction, or 70% including friction.

Sulphur-dioxide machines are not (1910) used in the United States.

**Refrigerating-Machines using Vapor of Water.** (Ledoux.)—In these machines, sometimes called vacuum machines, water, at ordinary temperatures, is injected into, or placed in connection with, a chamber in which a strong vacuum is maintained. A portion of the water vaporizes, the heat to cause the vaporization being supplied from the water not vaporized, so that the latter is chilled or frozen to ice. If brine is used instead of pure water, its temperature may be reduced below the freezing-point of water. The water vapor is compressed from, say, a pressure of 0.1 lb. per sq. in. to 1½ lbs. and discharged into a condenser. It is then condensed and removed by means of an ordinary air-pump: The principle of action of such a machine is the same as that of volatile-vapor machines.

A theoretical calculation for ice-making, assuming a lower temperature of 32° F., a pressure in the condenser of 1½ lbs. per sq. in. and a coal consumption of 3 lbs. per I.H.P. per hour, gives an ice-melting effect of 34.5 lbs. per pound of coal, neglecting friction. Ammonia for ice-making conditions gives 40.9 lbs. The volume of the compressing cylinder is about 150 times the theoretical volume for an ammonia machine for these conditions.

[The Patten Vacuum Ice Co., of Baltimore, has a large plant on this system in operation (1910).]

**Ammonia Compression-machines.**—"Cold" vs. "Dry" Systems of Compression.—In the "cold" system or "humid" system some of the ammonia entering the compression cylinder is liquid, so that the heat developed in the cylinder is absorbed by the liquid and the temperature of the ammonia thereby confined to the boiling-point due to the condenser-pressure. No jacket is therefore required about the cylinder.

In the "dry" or "hot" system all ammonia entering the compressor is gaseous, and the temperature becomes by compression several hundred degrees greater than the boiling-point due to the condenser-pressure. A water-jacket is therefore necessary to permit the cylinder to be properly lubricated.

**Dry, Wet and Flooded Systems.** (York Mfg. Co.)—An expansion system, or one where the ammonia leaves the coil slightly superheated, requires about 33⅓% more pipe surface than a wet compression system, in which the ammonia leaves the coils containing sufficient entrained liquid to maintain a wet compression condition in the compressor.

The flooded system is one where the ammonia is allowed to flow through the coils and into a trap, where the gas is separated from the liquid, the gas passing on to the compressor, while the liquid goes around through the coils again, together with the fresh liquid, which is fed into the trap. Such a system requires only about one-half the evaporating surface that



an expansion system does to do the same work. The relative proportions of the three systems may be expressed as follows:

A Dry Compression plant will need, with an Expansion Evaporating System, a medium size compressor, a large size evaporating system, a small amount of ammonia.

A Dry Compression plant will need, with a Flooded Evaporating System, a small size compressor, a small size evaporating system, a large amount of ammonia.

A Wet Compression plant will need, with a Wet Compression Evaporating System, a large size compressor, a medium size evaporating system, a medium amount of ammonia.

**The Ammonia Absorption-machine** comprises a generator which contains a concentrated solution of ammonia in water; this generator is heated either directly by a fire, or indirectly by pipes leading from a steam-boiler. The vapor passes first into an "analyzer," a chamber connected with the upper part of the generator which separates some of the water from the vapor, then into a rectifier, where the vapor is partly cooled, precipitating more water, which returns to the generator, and then to the condenser. The upper part of the cooler or brine-tank is in communication with the lower part of the condenser.

An absorption-chamber is filled with a weak solution of ammonia; a tube puts this chamber in communication with the cooling-tank.

The absorption-chamber communicates with the boiler by two tubes: one leads from the bottom of the generator to the top of the chamber, the other leads from the bottom of the chamber to the top of the generator. Upon the latter is mounted a pump, to force the liquid from the absorption-chamber, where the pressure is maintained at about one atmosphere into the generator, where the pressure is from 8 to 12 atmospheres.

To work the apparatus the ammonia solution in the generator is first heated. This releases the gas from the solution, and the pressure rises. When it reaches the tension of the saturated gas at the temperature of the condenser there is a liquefaction of the gas, and also of a small amount of steam. By means of a cock the flow of the liquefied gas into the refrigerating coils contained in the cooler is regulated. It is here vaporized by absorbing the heat from the substance placed there to be cooled. As fast as it is vaporized it is absorbed by the weak solution in the absorbing-chamber.

Under the influence of the heat in the boiler the solution is unequally saturated, the stronger solution being uppermost. The weaker portion is conveyed by the pipe entering the top of the absorbing-chamber, the flow being regulated by a cock, while the pump sends an equal quantity of strong solution from the chamber back to the boiler.

The working of the apparatus depends upon the adjustment and regulation of the flow of the gas and liquid; by these means the pressure is varied, and consequently the temperature in the cooler may be controlled.

The working is similar to that of compression-machines. The absorption-chamber fills the office of aspirator, and the generator plays the part of compressor. The mechanical force producing exhaustion is here replaced by the affinity of water for ammonia gas, and the mechanical force required for compression is replaced by the heat which severs this affinity and sets the gas at liberty.

Reece's absorption apparatus (1870) is thus described by Wallis-Taylor. The charge of liquid ammonia (26° Baumé) is vaporized by the application of heat, and the mixed vapor passed to the analyzer and rectifier, wherein the bulk of the water is condensed at a comparatively elevated temperature and returned to the generator. The ammoniacal vapor or gas is then passed to the condenser, where it is liquefied under the combined action of the cooling-water and of the pressure maintained in the generator. The liquid ammonia, practically anhydrous, is then used in the refrigerator, and the vapor therefrom, still under considerable pressure, is admitted to the cylinder of an engine used to drive a pump for returning the strong solution to the generator, after which it is passed to the absorber, where it meets and is absorbed by the weak liquor from the generator, and the strong liquor so formed is forced back into the generator by means of the pump. The temperature exchanger, introduced in 1875, provides for the hot liquor on its way from the generator to the absorber giving up its heat to the cooler liquid from the absorber on its way to the generator.

Wallis-Taylor describes also marine refrigerating, ice-making cold

storage, the application of refrigeration in breweries, dairies, etc.; and the management and testing of apparatus.

For the best results the following conditions are necessary (Voorhees):  
 1. The generator should have ample liquid evaporating surface to make dry gas. 2. The temperature of the gas to the rectifier should be as low as possible. 3. The drip liquor returned to the generator from the rectifier should be as hot as possible. 4. The gas from the rectifier to the condenser should not be over 10° to 50° hotter than the condensing temperature of the gas. 5. The exchanger should exchange upwards of 90% of the heat of the hot weak liquor to the cold strong liquor. The weight of strong liquor pumped should be from 7 to 8 times that of the anhydrous ammonia circulated in the refrigerator.

To produce one ton of refrigeration at 8.5 lbs. suction and 170 lbs. gauge condenser pressure, about 3.5 times as many heat units are actually used by an absorption machine as by a compression machine (compound condensing engine driven), but, owing to the low efficiency of the steam engine, due to the heat wasted in the exhaust and in cylinder condensation, the actual weight of steam used per hour per ton of refrigeration is the same for both the absorption machine and the compressor.

**Relative Performance of Ammonia Compression- and Absorption- machines, assuming no Water to be Entrained with the Ammonia-gas in the Condenser.** (Denton and Jacobus, *Trans. A. S. M. E.*, xiii.) — It is assumed in the calculation for both machines that 1 lb. of coal imparts 10,000 B.T.U. to the boiler. The condensed steam from the generator of the absorption-machine is assumed to be returned

Condenser.		Refrigerating Coils.		Temp. of Absorber, degrees F.	Pounds of Ice-melting Effect per lb. of Coal.				
Temp. in degrees Fahr.	Absolute pressure, lbs. per sq. in.	Temp. in degrees Fahr.	Absolute pressure, lbs. per sq. in.		Compress. Machine.		Absorption-Machine.*		
					Using 3 lbs. of coal per hour per I.H.P.	Using 1.6 lbs. of coal per hour per I.H.P.	Absorption-machine in which the ammonia circulating-pump exhausts into the generator.	In which the amm. circ. pump exhausts into the atmosphere through a heater, yielding 212° temp. to the feed-water.	Heat furnished to generator of absorption-machine, B.T.U. per lb. of ammonia circulated.
61.2	110.6	5	33.7	61.2	38.1	71.4	38.1	33.5	969
59.0	106.0	5	33.7	59.0	39.8	74.6	38.3	33.9	967
59.0	106.0	5	33.7	130.0	39.8	74.6	39.8	35.1	931
59.0	106.0	-22	16.9	59.0	23.4	43.9	36.3	31.5	1000
86.0	170.8	5	33.7	86.0	25.0	46.9	35.4	28.6	988
86.0	170.8	5	33.7	130.0	25.0	46.9	36.2	29.2	966
86.0	170.8	-22	16.9	86.0	16.5	30.8	33.3	26.5	1025
86.0	170.8	-22	16.9	130.0	16.5	30.8	34.1	27.0	1002
104.0	227.7	5	33.7	104.0	19.6	36.8	33.4	25.1	1002
104.0	227.7	-22	16.9	104.0	13.5	25.3	31.4	23.4	1041

\*5% of water entrained in the ammonia will lower the economy of the absorption-machine about 15% to 20% below the figures given in the table.

to the boiler at the temperature of the steam entering the generator. The engine of the compression-machine is assumed to exhaust through a feed-water heater that heats the feed-water to 212° F. The engine is assumed to consume 26¼ lbs. of water per hour per horse-power. The figures for the compression-machine include the effect of friction, which is taken at 15% of the net work of compression.

(For discussion of the efficiency of the absorption system, see Ledoux's work; paper by Prof. Linde, and discussion on the same by Prof. Jacobus, *Trans. A. S. M. E.*, xiv, 1416, 1436; and papers by Denton and Jacobus, *Trans. A. S. M. E.*, x, 792, xiii, 507.

**Relative Efficiency of a Refrigerating-Machine.**—The efficiency of a refrigerating-machine is sometimes expressed as the quotient of the quantity of heat received by the ammonia from the brine, that is, the quantity of useful work done, divided by the heat equivalent of the mechanical work done in the compressor. Thus in column 1 of the table of performance of the 75-ton machine (page 1363) the heat given by the brine to the ammonia per minute is 14,776 B.T.U. The horse-power of the ammonia cylinder is 65.7, and its heat equivalent =  $65.7 \times 33,000 \div 778 = 2786$  B.T.U. Then  $14,776 \div 2786 = 5.304$ , efficiency. The apparent paradox that the efficiency is greater than unity, which is impossible in any machine, is thus explained. The working fluid, as ammonia, receives heat from the brine and rejects heat into the condenser. (If the compressor is jacketed, a portion is rejected into the jacket-water.) The heat rejected into the condenser is greater than that received from the brine; the difference (plus or minus a small difference radiated to or from the atmosphere) is heat received by the ammonia from the compressor. The work to be done by the compressor is not the mechanical equivalent of the refrigeration of the brine, but only that necessary to supply the difference between the heat rejected by the ammonia into the condenser and that received from the brine. If cooling water colder than the brine were available, the brine might transfer its heat directly into the cooling water, and there would be no need of ammonia or of a compressor; but since such cold water is not available, the brine rejects its heat into the colder ammonia, and then the compressor is required to heat the ammonia to such a temperature that it may reject heat into the cooling water.

The maximum theoretical efficiency of a refrigerating machine is expressed by the quotient  $T_0 \div (T_1 - T_0)$ , in which  $T_1$  is the highest and  $T_0$  the lowest temperature of the ammonia or other refrigerating agent.

The efficiency of a refrigerating plant referred to the amount of fuel consumed is

$$\left. \begin{array}{l} \text{Ice-melting capacity} \\ \text{per pound of fuel} \end{array} \right\} = \frac{\left\{ \begin{array}{l} \text{Pounds circulated per hour} \\ \times \text{specific heat} \times \text{range} \\ \text{of temperature} \end{array} \right\} \text{ of brine or other} \\ \text{circulating fluid}}{144 \times \text{pounds of fuel used per hour}}$$

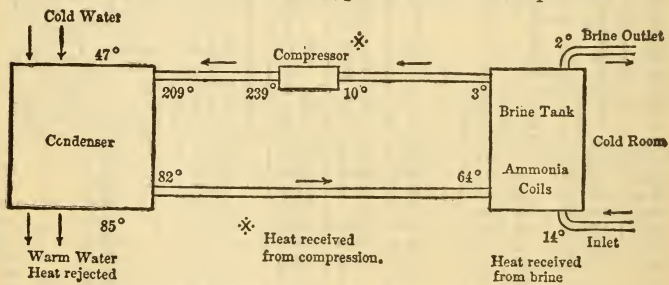

DIAGRAM OF AMMONIA COMPRESSION MACHINE.

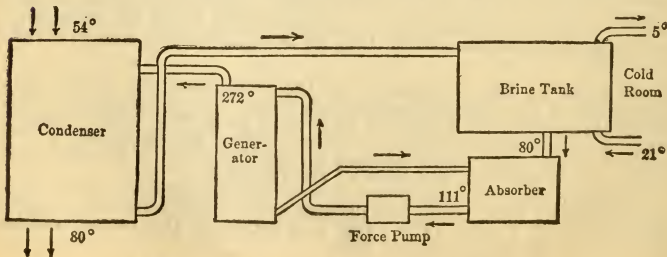

DIAGRAM OF AMMONIA ABSORPTION MACHINE.



The ice-melting capacity is expressed as follows:

$$\left. \begin{array}{l} \text{Tons (of 2000 lbs.)} \\ \text{ice-melting ca-} \\ \text{pacity per 24 hours} \end{array} \right\} = \frac{\left\{ \begin{array}{l} 24 \times \text{pounds} \\ \times \text{specific heat} \\ \times \text{range of temp.} \end{array} \right\} \text{ of brine circulated per hour}}{144 \times 2000}$$

The analogy between a heat-engine and a refrigerating-machine is as follows: A steam-engine receives heat from the boiler, converts a part of it into mechanical work in the cylinder, and throws away the difference into the condenser. The ammonia in a compression refrigerating-machine receives heat from the brine-tank or cold room, receives an additional amount of heat from the mechanical work done in the compression-cylinder, and throws away the sum into the condenser. The efficiency of the steam-engine = work done ÷ heat received from boiler. The efficiency of the refrigerating-machine = heat received from the brine-tank or cold-room ÷ heat required to produce the work in the compression-cylinder. In the ammonia absorption-apparatus, the ammonia receives heat from the brine-tank and additional heat from the boiler or generator, and rejects the sum into the condenser and into the cooling water supplied to the absorber. The efficiency = heat received from the brine ÷ heat received from the boiler.

**The Efficiency of Refrigerating Systems** depends on the temperature of the condenser water, whether there is sufficient condenser surface for the compressor and whether or not the condenser pipes are free from uncondensable foreign gases. With these things right, condenser pressure for different temperatures of cooling water should be approximately as follows:

1 gallon per minute per ton per 24 hours							
—Cooling water, ° F.....	60	65	70	75	80	85	90
Condenser pressure, gage, lb.....	183	200	220	235	255	280	300
Condensed liquid ammonia, ° F.....	95	100	105	110	115	120	125
2 gallons per minute per ton per 24 hours—							
Condenser pressure, gage, lb.....	130	153	168	183	200	220	235
Condensed liquid ammonia, ° F.....	77	85	90	93	100	105	110
3 gallons per minute per ton per 24 hours—							
Condenser pressure, gage, lb.....	125	140	155	170	185	200	215
Condensed liquid ammonia, ° F.....	75	85	90	93	95	100	105

The evaporating or back pressure within the expansion coils of a refrigerating system depends upon the temperatures on the outside of such coils, i.e., the air or brine to be cooled. For average practice back pressures for the production of required temperatures should be approximately as follows:

Temperature of room, ° F....	10	15	20	28	32	36	40	50	60
Back pressure, gage, lb.....	10	12	15	22	25	27	30	35	40
Temperature of ammonia, ° F.—	10	—5	0	8	12	14	17	22	26

The condenser pressure should be kept as low as possible and the back pressure as high as possible, narrow limits between such pressures being as important to the efficiency of a refrigerating system as wide ones are to that of a steam engine in which the economy increases with the range between boiler pressure and condenser pressure. (F. E. Matthews, *Power*, Jan. 26, 1909.)

**Cylinder-heating.**—In compression-machines employing volatile vapors the principal cause of the difference between the theoretical and the practical result is the heating of the ammonia, by the warm cylinder walls, during its entrance into the compressor, thereby expanding it, so that to compress a pound of ammonia a greater number of revolutions must be made by the compressing-pumps than corresponds to the density of the ammonia-gas as it issues from the brine-tank.

**Volumetric Efficiency.**—The volumetric efficiency of a compressor is the ratio of the actual weight of ammonia pumped to the amount calculated from the piston displacement. Mr. Voorhees deduces from Denton's experiments the formula: Volumetric efficiency =  $E = 1 - (t_1 - t_0)/1330$ , in which  $t_1$  = the theoretical temperature of gas after compression and  $t_1$  = temperature of gas delivered to the compressor. The temperature  $t_1$ , =  $T_1 - 460$ , is calculated from the formula for adiabatic compression,  $T_1 = T_0 (P_1/P_0)^{0.24}$ , in which  $T_1$  and  $T_0$  are absolute temperatures and  $P_1$  and  $P_0$  absolute pressures. In eight tests by Prof. Denton the volumetric efficiency ranged from 73.5% to 84%, and they

# 1350 ICE-MAKING OR REFRIGERATING-MACHINES.

vary less than 1% from the efficiencies calculated by the formula. The temperature of the gas discharged from the compressor averaged 57° less than the theoretical.

The volumetric efficiency of a dry compressor is greatest when the vapor comes to the compressor with little or no superheat; 30° superheat of the suction gas reduces the capacity of the compressor 4%, and 100° 9%.

The following table (from Voorhees) gives the theoretical discharge temperatures ( $t_1$ ) and volumetric efficiencies ( $E$ ) by the formula, and the actual cubic feet of displacement of compressor ( $F$ ) per ton of refrigeration per minute for the given gage pressures of suction and condenser.

Suction Pressures.	0			15			30		
	$t_1$	$E$	$F$	$t_1$	$E$	$F$	$t_1$	$E$	$F$
Cond. press., 140..	323°	0.76	10.35	358°	0.73	11.02	388°	0.71	11.57
Cond. press., 170..	221°	0.83	4.57	254°	0.81	4.78	280°	0.79	5.03
Cond. press., 200..	167°	0.87	2.96	192°	0.86	3.07	216°	0.84	3.21

**Pounds of Ammonia per Minute to Produce 1 Ton of Refrigeration, and Percentage of Liquid Evaporated at the Expansion Valve.**

Condenser Pressure and Temperature.	140 lbs., 80°.	170 lbs., 90°.	200 lbs., 100°.
Refrigerator, pressure and temperature 0 lbs., -29°...	0.431 lb., 19%	0.441 lb., 20.8%	0.451 lb., 22.5%
Refrigerator pressure and temperature 15 lbs., -0°...	0.420 lb., 14.4%	0.430 lb., 16.2%	0.440 lb., 18.0%
Refrigerator pressure and temperature, 30 lbs., -17°..	0.415 lb., 11.6%	0.425 lb., 13.4%	0.434 lb., 15.2%

**Mean Effective Pressure, and Horse-power.**—Voorhees deduces the following (*Ice and Refrig.*, 1902): M.E.P. =  $4.333 p_0 [(p_1/p_0)^{0.231} - 1]$ ,  $p_0$  = suction and  $p_1$  condenser pressure, abs. lbs. per sq. in. The maximum M.E.P. occurs when  $p_0 = p_1 \div 3.113$ . The percentage of stroke during which the gas is discharged from the compressor is  $V_1 = (p_0/p_1)^{0.769}$ .

The compressor horse-power, C.H.P., is  $0.00437 F \times \text{M.E.P.}$

The friction of the compressor and its engine combined is given by Voorhees as  $33\frac{1}{3}\%$  of the compressor H.P. or 25% of the engine H.P. Values of the mean effective pressure per ton of refrigeration (M), the compressor horse-power (C) and the engine horse-power (E) are given below for the conditions named.

Suction Pressure.	0			15			30		
	(M)	(C)	(E)	(M)	(C)	(E)	(M)	(C)	(E)
Cond. press., 140...	46.5	2.10	2.80	59.5	1.19	1.59	64.5	0.83	1.11
Cond. press., 170...	50.5	2.42	3.23	67.0	1.40	1.87	75.0	1.00	1.33
Cond. press., 200...	55.0	2.78	3.71	74.5	1.64	2.19	85.0	1.19	1.59

By cooling the liquid between the condenser and the expansion valve the capacity will be increased and the horse-power per ton reduced. With compression from 15 to 170 lbs., if the liquid at the expansion valve is cooled to 76° instead of 90° the H.P. per ton will be reduced 3%.

Prof. Lucke deduces a formula for the I.H.P. per ton of refrigerating capacity, as follows:

$p$  = mean effective pressure, lbs. per sq. in.;  $L$  = length of stroke in ft.;  $a$  = area of piston in sq. ins.;  $n$  = no. of compressions per minute;  $E_c$  = apparent volumetric efficiency, the ratio of the volume of ammonia apparently taken in per stroke to the full displacement of the piston;  $w_c$  = weight of 1 cu.ft. of ammonia vapor at the back pressure, as it exists in the cylinder when compression begins;  $L_c$  = latent heat of vaporization available for refrigeration; 288,000 = B.T.U. equivalent to 1 ton of refrigeration;  $T$  = tons refrigeration per 24 hours.

$$\frac{\text{I.H.P.}}{T} = \frac{pLan \div 33,000}{LaE_c n w_c \times L_c \times 60 \times 24} = \frac{0.87}{W_c L_c} \times \frac{p}{E_c}$$

$$144 \times 288,000$$

The Voorhees Multiple Effect Compressor is based upon the fact that both the economy and the capacity of a compression machine vary with the back pressure. In the past it has always been necessary to run a compressor at a gas suction pressure corresponding to the lowest required

temperature. The multiple effect compressor takes in gas from two or more refrigerators at two or more different suction pressures and temperatures on the same suction stroke of the compressor. The suction gas of the higher pressure helps to compress the lower suction pressure gas. There are two sets of suction valves in the compressor cylinder; the low temperature and corresponding low back pressure being connected to one suction port, usually in the cylinder head, and the high back pressure connected to the other. At the beginning of the stroke the cylinder is filled with the low pressure gas and as the piston reaches the end of its suction stroke, the second or high back pressure port is uncovered, the low pressure suction valve closing automatically, and the cylinder is completely filled with gas at the high pressure. By this means the compressor operates with an economy and capacity corresponding to the higher back pressure, making a gain in capacity of often 50% or more. (*Trans. Am. Soc. Refrig. Engrs.*, 1906.)

**Quantity of Ammonia Required per Ton of Refrigeration.**—

The following table is condensed from one given by F. E. Matthews in *Trans. A. S. M. E.*, 1905. The weight in lbs. per minute is calculated from the formula  $P = (144 \times 2000) \div [1440l - (h_1 - h_0)]$  in which  $l$  is the latent heat of evaporation at the back pressure in the cooler, and  $h_1$  and  $h_0$  the heat of the liquid at the temperatures of the condenser and the cooler respectively. The specific heat of the liquid has been taken at unity. The ton of refrigeration is 2000 lbs. in 24 hours = 288,000 B.T.U.

$B$  = Pounds of ammonia evaporated per minute.

$C$  = Cubic feet of gas to be handled per minute by the compressor.

l. w. B.P.	Head or Condenser Gauge Pressure and Corresponding Temperature.										
	100 lb. 63.5°	110 lb. 68°	120 lb. 72.6°	130 lb. 77.4°	140 lb. 80.3°	150 lb. 83.8°	160 lb. 87.4°	170 lb. 90.8°	180 lb. 93.8°	190 lb. 96.9°	200 lb. 100°
572.78 } .0556 } 0	B .4159	.4199	.4240	.4284	.4310	.4343	.4376	.4408	.4440	.4470	.4501
	C 7.482	7.551	7.626	7.703	7.761	7.812	7.870	7.929	7.986	8.041	8.095
566.14 } .0133 } 5	B .4122	.4160	.4202	.4243	.4271	.4308	.4335	.4366	.4397	.4437	.4458
	C 5.636	5.675	5.732	5.790	5.826	5.878	5.914	5.970	5.999	6.039	6.081
560.69 } .0910 } 10	B .4093	.4130	.4171	.4204	.4237	.4271	.4302	.4332	.4363	.4392	.4423
	C 4.502	4.543	4.587	4.625	4.662	4.698	4.733	4.766	4.799	4.833	4.865
556.11 } .1083 } 15	B .4068	.4106	.4145	.4186	.4211	.4244	.4276	.4288	.4336	.4365	.4394
	C 3.756	3.791	3.827	3.866	3.889	3.918	3.948	3.975	4.003	4.030	4.058
552.83 } .1258 } 20	B .4040	.4077	.4116	.4158	.4182	.4214	.4245	.4275	.4304	.4333	.4362
	C 3.211	3.241	3.272	3.305	3.324	3.350	3.375	3.398	3.422	3.444	3.467
548.40 } .1429 } 25	B .4025	.4062	.4102	.4140	.4167	.4198	.4229	.4258	.4287	.4316	.4345
	C 2.819	2.843	2.870	2.898	2.916	2.938	2.959	2.980	3.000	3.020	3.040
545.13 } .1600 } 30	B .4013	.4049	.4088	.4128	.4152	.4184	.4213	.4243	.4273	.4300	.4329
	C 2.507	2.530	2.555	2.580	2.600	2.615	2.633	2.653	2.671	2.687	2.706
542.80 } .1766 } 35	B .3991	.4028	.4066	.4105	.4130	.4161	.4188	.4220	.4249	.4277	.4305
	C 2.260	2.280	2.302	2.925	2.338	2.356	2.373	2.390	2.406	2.422	2.443
539.35 } .1941 } 40	B .3984	.4020	.4058	.4098	.4122	.4153	.4183	.4211	.4240	.4269	.4296
	C 2.052	2.071	2.090	2.111	2.123	2.139	2.155	2.175	2.185	2.200	2.214

$l$ , Latent heat of volatilization.  $w$ , weight of vapor per cubic foot. B.P. back pressure or suction gauge pressure.

Back pressures 0 5 10 15 20 25 30 35 40  
Temperatures. -28.5° -17.5° -8.5° -1° 5.66° 11.5° 16.8° 21.7° 26.1°

Mr. Matthews defines a standard ton of refrigeration as the equivalent of 27 lbs. of anhydrous ammonia evaporated per hour from liquid



# 1352 ICE-MAKING OR REFRIGERATING-MACHINES.

at 90° F. into saturated vapor at 15.67 lbs. gauge pressure (0° F.), which requires 12,000 B.T.U.; or 20,950 units of evaporation, each of which is equal to 572.78 B.T.U., the heat required to evaporate 1 lb. of ammonia from a temperature of - 28.5° F. into saturated vapor at atmospheric pressure.

**Size and Capacities of Ammonia Refrigerating - Machines.**—York Mfg. Co. Based on 15.67 lbs. back pressure, 185 lbs. condensing pressure, and condensing water at 60° F.

SINGLE-ACTING COMPRESSORS.					DOUBLE-ACTING COMPRESSORS.				
Compressors.		Engine.		Capacity Tons Refrigeration.	Compressors.		Engine.		Capacity Tons Refrigeration.
Bore.	Stroke.	Bore.	Stroke.		Bore.	Stroke.	Bore.	Stroke.	
7 1/2	10	11 1/2	10	10	9	15	13 1/2	12	20
9	12	13 1/2	12	20	11	18	16	15	30
11	15	16	15	30	12 1/2	21	18	18	40
12 1/2	18	18	18	40	14	24	20	21	65
14	21	20	21	65	16	28	24	24	90
16	24	24	24	90	18	32	26	28	125
18	28	26	28	125	21	36	28 1/2	32	175
21	32	28 1/2	32	175	24	40	34	36	250
24	36	34	36	250	26	60	38	54	350
27	42	36	42	350					
30	48	44	48	500					

For larger capacities the machines are built with duplex compressors, driven by simple, tandem or cross compound engines.

**DISPLACEMENT AND HORSE-POWER PER TON OF REFRIGERATION**  
Dry Compression. S.A., Single-acting; D.A., Double-acting.

Condenser Gauge Pressure and Corresp. Temp. of Liquid at Expansion Valve.	Suction Gauge Pressure and Corresponding Temp.									
	5 lb. = - 17.5° F.		10 lb. = - 8.5° F.		15.67 lb. = 0° F.		20 lb. = 5.7° F.		25 lb. = 11.5° F.	
	Cu. In. Disp.*	I.H.P. per Ton.	Cu. In. Disp.	I.H.P. per Ton.	Cu. In. Disp.	I.H.P. per Ton.	Cu. In. Disp.	I.H.P. per Ton.	Cu. In. Disp.	I.H.P. per Ton.
145 lb. 82° F., S.A...	12,608	1.654	9,811	1.4	7829	1.195	6765	1.065	5836	0.943
145 lb. 82° F., D.A..	14,645	1.921	11,300	1.612	8901	1.358	7625	1.2	6522	1.054
165 lb. 89° F., S.A..	13,045	1.834	10,148	1.56	8092	1.341	6990	1.201	6027	1.071
165 lb. 89° F., D.A.	15,203	2.137	11,720	1.802	9224	1.529	7898	1.357	6751	1.2
185 lb. 95.5° F., S.A.	13,491	2.013	10,487	1.72	8362	1.4865	7219	1.336	6223	1.197
185 lb. 95.5° F., D.A.	15,774	2.354	12,150	1.993	9555	1.7	8176	1.513	6985	1.344
205 lb. 101.4° F., S.A.	13,947	2.192	10,834	1.879	8630	1.631	7450	1.47	6420	1.323
205 lb. 101.4° F., D.A.	16,362	2.571	12,590	2.184	9890	1.87	8459	1.67	7222	1.488

\* Cu. in. Displacement per Min. per Ton of Refrigeration.

The volumetric efficiency ranges from 63.5 to 76.5% for double-acting and from 74.5 to 85.5% for single-acting compressors, increasing with the decrease of condenser pressure and with the increase of suction pressure.

Where the liquid is cooled lower than the temperature corresponding to the condensing pressure, there will be a reduction in horse-power and displacement proportional to the increase of work done by each pound of liquid handled. The I.H.P. is that of the compressor. For Engine Horse-power add 17% up to 20 tons capacity and 15% for larger machines.

## SMALL SIZES OF REFRIGERATING-MACHINES.

Capacity, tons	Single-acting, Vertical.			Double-acting, Horizontal.		
	1 1/4	3	6	2 1/2	6	10
Compressor, diam., in.	4 1/2	6	2-6	4	5 1/2	7
Compressor, stroke, in.	5	6	6	6	8	10
Engine, diam., in.	5	6	8	6	8	10
Engine, stroke, in.	5	6	6	8	8	10

**Rated Capacity of Refrigerating-Machines.** — It is customary to rate refrigerating machines in tons of refrigerating capacity in 24 hours, on the basis of a suction pressure of 15.67 lbs. gauge, corresponding to 0° F. temperature of saturated ammonia vapor, and a condensing pressure of 185 lbs. gauge, corresponding to 95.5° F. The actual capacity increases with the increase of the suction pressure, and decreases with the increase of the condensing pressure. The following table shows the calculated capacities and horse-power of a machine rated at 40 H.P., when run at different pressures. (York Mfg. Co.) The horse-power required increases with the increase of both the suction and the condensing pressure.

Condenser Press. Temp.	Suction Gauge Pressure and Corresponding Temp.											
	5 lb. = -17.5° F		10 lb. = -8.5° F.		15.67 lb. =0° F.		20 lb. = 5.7° F.		25 lb. = 11.5° F.		30 lb. = 16.8° F.	
	Tons.	H.P.	Tons.	H.P.	Tons.	H.P.	Tons.	H.P.	Tons.	H.P.	Tons.	H.P.
145 lb. = 82° F. ....	26.6	50.6	34.2	55.1	42.8	58.8	49.6	60.7	57.5	62.3	65.3	63.4
165 lb. = 89° F. ....	25.7	54.2	33.1	59.4	41.4	63.8	48	66.3	55.7	68.6	63.2	70.1
185 lb. = 95.5° F. ....	24.8	57.4	32	63.3	40	68.6	46.5	71.4	53.9	74.2	61.3	76.5
205 lb. = 101.4° F. ....	24	60.5	31	67	38.9	72.9	45	76.1	52.3	79.6	59.4	86.2

**Piston Speeds and Revolutions per Minute.**—There is a great diversity in the practice of different builders as to the size of compressor, the piston speed and the number of revolutions per minute for a given rated capacity. F. E. Matthews, *Trans. A. S. M. E.*, 1905, has plotted a diagram of the various speeds and revolutions adopted by four prominent builders, and from average curves the following figures are obtained:

Tons. ....	20	30	40	50	60	80	100	120	140	160	180	200	240	300	400	500
R.P.M. ....	90	78	73	68	64	60	58 1/2	57	56	55	54	53	52	51	48 1/2	46
Piston speeds.	200	215	228	240	250	270	280	286	290	293	296	300	315	340	378	425

Mr. Matthews recommends a standard rating of machines based on these revolutions and speeds and on an apparent compressor displacement of 4.4 cu. ft. per minute per ton rating.

**Condensers for Refrigerating-Machines** are of two kinds: submerged, and open-air evaporative. The submerged condenser requires a large volume of cooling water for maximum efficiency. According to Siebel the amount of condensing surface, the water entering at 70° and leaving at 80°, is 40 sq. ft. for each ton of refrigerating capacity, or 64 lineal feet of 2-in. pipe. Frequently only 20 sq. ft., or 90 ft. of 1 1/4-in. pipe, is used, but this necessitates higher condenser pressures. If  $F$  = sq. ft. of cooling surface,  $h$  = heat of evaporation of 1 lb. ammonia at the condenser temperature,  $K$  = lbs. of ammonia circulated per minute,  $m$  = B.T.U. transferred per minute per sq. ft. of condenser surface,  $t$  = temperature of the ammonia in the coils and  $t_1$  the temperature of the water outside,  $F = hK \div m(t - t_1)$ . For  $t = 80$  and  $t_1 = 70$ ,  $m$  may be taken at 0.5. Practically the amount of water required will vary from 3 to 7 gallons per minute per ton of refrigeration. When cooling water is scarce, cooling towers are commonly used.

E. T. Shinkle gives the average surface of several submerged condensers as equal to 167 lineal feet of 1-in. pipe per ton of refrigeration.

Open air or evaporation surface condensers are usually made of a stack of parallel tubes with return bends, and means for distributing the water so that it will flow uniformly over the pipe surface. Shinkle gives as the average surface of open-air coolers 142 ft. of 1-in. pipe, or 99 ft. of 1 1/4 in. pipe per ton of refrigerating capacity.

**CAPACITY OF CONDENSERS.** (York Mfg. Co.) — The following table shows the capacities and horse-power per ton refrigeration of one section counter-current double-pipe condenser, 1 1/4-in. and 2-in. pipe, 12 pipes high, 19 feet in length outside of water bends, for water velocities 100 ft. to 400 ft. per minute: initial temperature of condensing water 70°.

The horse-power per ton is for single-acting compressor with 15.67 lbs. suction pressure.

The friction in water pump and connections should be added to water horse-power and to total horse-power.

**Capacity of Condensers**

**High Pressure Constant.**

Condensing Water.				Cap'y Tons Refrig. per 24 hours.	Con- densing Pressure Lbs. per sq. in.	Horse-power per Ton Refrigeration.		
Veloc- ity thr'gh 1/4-in. pipe. Ft. per min.	Total gallons used per min.	Gallons per min per ton Refrig.	Fric- tion thr'gh Coil. Lbs. per sq. in.			Engine driving Com- pressor	Circu- lating Water thr'gh Con- denser.	Total Engine and Water Circu- lation.
100	7.77	1.16	2.28	6.7	185	1.71	0.0016	1.7116
150	11.65	1.165	5.75	10.	185	1.71	0.004	1.714
200	15.54	1.165	9.98	13.4	185	1.71	0.007	1.717
250	19.42	1.18	15.	16.4	185	1.71	0.011	1.721
300	23.31	1.24	21.6	18.8	185	1.71	0.016	1.726
400	31.08	1.30	37.8	24.	185	1.71	0.030	1.74

**Capacity Constant.**

100	7.77	0.777	2.28	10.	225	2.04	0.001	2.041
150	11.65	1.165	5.75	10.	185	1.71	0.004	1.714
200	15.54	1.554	9.98	10.	165	1.54	0.009	1.549
250	19.42	1.942	15.	10.	155	1.46	0.018	1.478
300	23.31	2.331	21.6	10.	148	1.40	0.030	1.43
400	31.08	3.108	37.8	10.	140	1.33	0.071	1.401

**Cooling-Tower Practice in Refrigerating-Plants.** (B. F. Hart, Jr., *Southern Engr.*, Mar., 1909.)—The efficiency of a cooling-tower depends on exposing the greatest quantity of water surface to the cooling air-currents. In a tower designed to handle 100 gallons per minute the ranges of temperature found when handling different quantities of water were as follows:

Gallons of water per minute.....	148	109	58
Temperature of the atmosphere.....	78°	78.5°	78°
Relative humidity, %.....	47	49	47
Initial temperature.....	85.5°	85°	86°
Final temperature.....	78°	76°	75°
Range.....	7.5°	9°	11°

The final temperatures which may be obtained when the initial temperature does not exceed 100° are as follows:

Atmosphere Temp.		95°	90°	85°	80°	75°	70°
		Final temperature of water leaving tower.					
Humidity, %	90	100	95	90	85	80	75
	80	98	92	88	83	78	73
	70	95	90	86	80	76	71
	60	92	88	83	78	74	69
	50	89	84	79	75	70	66
	40	85	80	76	71	67	63

For ammonia condensers we figure on supplying 3 gallons per minute of circulating water per ton of refrigeration, or 6 gallons per minute per ton of ice made per 24 hours, and guarantee a reduction range from 150° to 160° down to about 100° when the temperature of the atmosphere does not exceed 80° nor the relative humidity 60%. When the temperature of the atmosphere and the humidity are both above 90° the speed of the pumps and the ammonia pressure must be increased.

The **Refrigerating-Coils** of a Pictet ice-machine described by Ledoux had 79 sq. ft. of surface for each 100,000 theoretic negative heat-units produced per hour. The temperature corresponding to the pressure of the dioxide in the coils is 10.4° F., and that of the bath (calcium chloride solution) in which they were immersed is 19.4°.



**Comparison of Actual and Theoretical Ice-melting Capacity.**—The following is a comparison of the theoretical ice-melting capacity of an ammonia compression machine with that obtained in some of Prof. Schröter's tests on a Linde machine having a compression-cylinder 9.9-in. bore and 16.5 in. stroke, and also in tests by Prof. Denton on a machine having two single-acting compression-cylinders, 12 in. × 30 in.:

No. of Test.	Temp. in Degrees F. Corresponding to Pressure of Vapor.		Ice-melting Capacity per lb. of Coal, assuming 3 lbs. per hour per Horse-power.			
	Condenser.	Suction.	Theoretical Friction* Included.	Actual.	Per cent of Loss Due to Cylinder Superheating.	
Schröter {	1	72.3	26.6	50.4	40.6	19.4
	2	70.5	14.3	37.6	30.0	20.2
	3	69.2	0.5	29.4	22.0	25.2
	4	68.5	-11.8	22.8	16.1	29.4
Denton {	24	84.2	15.0	27.4	24.2	11.7
	26	82.7	- 3.2	21.6	17.5	19.0
	25	84.6	-10.8	18.8	14.5	22.9

\* Friction taken at figures observed in the tests, which range from 14% to 20% of the work of the steam-cylinder.

### TEST-TRIALS OF REFRIGERATING-MACHINES.

(G. Linde, *Trans. A. S. M. E.*, xiv, 1414.)

The purpose of the test is to determine the ratio of consumption and production, so that there will have to be measured both the refrigerative effect and the heat (or mechanical work) consumed, also the cooling water. The refrigerative effect is the product of the number of heat-units ( $Q$ ) abstracted from the body to be cooled, and the quotient  $(T_c - T) \div T$ : in which  $T_c$  = absolute temperature at which heat is transmitted to the cooling water, and  $T$  = absolute temperature at which heat is taken from the body to be cooled.

The determination of the quantity of cold will be possible with the proper exactness only when the machine is employed during the test to refrigerate a liquid; and if the cold be found from the quantity of liquid circulated per unit of time, from its range of refrigeration, and from its specific heat. Sufficient exactness cannot be obtained by the refrigeration of a current of circulating air, nor from the manufacture of a certain quantity of ice, nor from a calculation of the fluid circulating within the machine (for instance, the quantity of ammonia circulated by the compressor). Thus the refrigeration of brine will generally form the basis for tests making any pretension to accuracy. The degree of refrigeration should not be greater than necessary for allowing the range of temperature to be measured with the necessary exactness; a range of temperature of from 5° to 6° Fahr. will suffice.

The condenser measurements for cooling water and its temperatures will be possible with sufficient accuracy only with submerged condensers.

The measurement of the quantity of brine circulated, and of the cooling water, is usually effected by water-meters inserted into the conduits. If the necessary precautions are observed, this method is admissible. For quite precise tests, however, the use of two accurately gauged tanks which are alternately filled and emptied must be advised.

To measure the temperatures of brine and cooling water at the entrance and exit of refrigerator and condenser respectively, the employment of specially constructed and frequently standardized thermometers is indispensable; no less important is the precaution of using at each spot simultaneously two thermometers, and of changing the position of one such thermometer series from inlet to outlet (and *vice versa*) after the expiration of one-half of the test, in order that possible errors may be compensated.

It is important to determine the specific heat of the brine used in each instance for its corresponding temperature range, as small differences in the composition and the concentration may cause considerable variations.

(Continued on page 1358.)

**Ammonia Compression-machines.**—Ammonia gas possesses the advantage of affording about three times the useful effect of sulphur dioxide for the same volume described by the piston. The perfection of ammonia apparatus now renders it so convenient and reliable that no practical advantage results from the lower pressures afforded by sulphur dioxide. The results of the calculations for ammonia are given in the table below:

PERFORMANCE OF AMMONIA COMPRESSION-MACHINES.

Gas superheated during compression as in ordinary practice. Temperature of condenser, 64.4° Fahr. Pressure in condenser, 117.44 lbs per sq. in. (Ledoux.)

Temperature Corresponding to Pressure of Vapor in Refrigerating-coils.	Absolute Pressure in Refrigerating-coils.	$t_2$	Temperature of Gas at End of Compression.	Per Cubic Foot of Piston Displacement.				Performance in British Thermal Units.		Ice-melting Capacity per Cubic Foot of Piston Displacement.	Ice-melting Capacity per lb. of Coal, assuming 3 lbs. of Coal per hour per H.P. of Steam-cylinder. With Friction.	Condensing-water. Per Ton of Ice-melting Capacity, assuming 30° F. Range of Temperature.		
				Weight of Gas Compressed.	Heat Abstracted at Condenser.	Number of Negative Thermal Units Developed.	Work of Compression. Without Friction.	With Friction, or Indicated Steam-power.	Per cent.-lb. of Work With Friction.				Per hour per Horse-power. With Friction.	
Deg. F.	Lbs. per sq. in.	Deg. F.	Deg. F.	$m$	$Q_1$	B.T.U.	$Q$	$W_r$	Ft.-lbs.	$1.15W_r$	Ft.-lbs.	Tons.	Lbs.	Gals.
9.66	37.76	158.9	158.9	0.1329	78.56	69.41	69.41	7070	8130	16,900	8130	0.000244	39.6	1290
5.00	33.67	170.1	170.1	0.1206	71.98	62.77	62.77	7120	8190	15,170	8190	0.000221	35.6	1310
-22.00	16.95	241.3	241.3	0.0639	40.45	32.58	32.58	6080	6990	9,230	6990	0.000115	21.6	1410

The theoretical results for ammonia are higher than the actual, for the same reasons that have been stated for sulphur dioxide. In the case of ammonia the action of the cylinder-walls in superheating the entering vapor has been determined experimentally by Prof. Denton, and the amount found to agree with that indicated by theory. In these experiments the ammonia circulated in a 75-ton refrigerating machine was measured directly by means of a special meter, so that, in addition to determining the effect of superheating, the latent heats can be calculated at the suction and condenser pressure.

Economy of Ammonia Compression-machines at Various Condenser Temperatures. (LEDOUX.)

REFRIGERATING EFFECT OF 1 CU. FT. OR 0.12061 LB. OF AMMONIA EXPANDED THROUGH A SIMPLE COCK TO 33.67 LBS. ABSOLUTE PRESSURE PER SQ. IN., AND TAKEN INTO THE COMPRESSOR AT THIS PRESSURE AND THE CORRESPONDING TEMPERATURE OF 5° F.

Temp. Due to Press. of Vapor in Condenser.	Deg. F.	Lbs. per sq.in.	Temperature at End of Compression.	Heat Carried away from Condenser.	Refrigerating Effect in Heat Units.	Ratio of Refrigerating Effect to Heat Expended.	Work of Compression, without Friction.	Work of Compression, with Friction, or Indicated Steam-power.	Refrigerating Effect in Heat Units.			Ice-melting Capacity.						Condensing-water		
									Per ft.-lb. of Work Expended, without Friction.	Per ft.-lb. of Work Expended, including Friction.	Per Hour per H.P., including Friction.	Per Hour per H.P.	Without Friction.	With Friction.	Without Friction.	With Friction.	Per Lb. of Coal.	Per cu. ft. of Piston Displacement.	Per cu. ft. of Piston Displacement, assuming 30° Range of Temp.	Per Ton of Ice-melting Capacity.
(1)	(2)	(3)	(4)	(5)	(6)	(7)	(8)	(9)	(10)	(11)	(12)	(13)	(14)	(15)	(16)	(17)	(18)	(19)		
59	106.0	154.6	71.81	63.47	7.61	6,450	7,410	.00984	.00857	16,960	137.0	119.3	45.8	39.8	.000223	0.2872	1290	0.89		
68	125.1	179.9	72.05	62.31	6.40	7,530	8,660	.00827	.00719	14,250	115.2	100.2	38.4	33.4	.000219	.2882	1320	.92		
77	146.6	205.1	72.26	61.13	5.49	8,600	9,890	.00711	.00618	12,240	99.0	86.1	33.0	28.7	.000215	.2890	1350	.94		
86	170.8	230.3	72.46	59.93	4.78	9,680	11,130	.00619	.00538	10,660	86.2	75.0	28.7	25.0	.000211	.2898	1380	.96		
95	197.8	255.4	72.61	58.70	4.22	10,750	12,360	.00546	.00475	9,400	76.0	66.1	25.3	22.0	.000206	.2904	1410	.98		
104	227.8	280.3	72.74	57.45	3.76	11,820	13,590	.00486	.00423	8,380	67.7	58.9	22.6	19.6	.000202	.2910	1440	1.00		

REFRIGERATING EFFECT OF 1 CU. FT. OF AMMONIA EXPANDED THROUGH A SIMPLE COCK TO 16.95 LBS. ABSOLUTE PRESSURE PER SQ. IN., AND TAKEN INTO THE COMPRESSOR AT THIS PRESSURE AND THE CORRESPONDING TEMPERATURE OF -22° F.																		
(1)	(2)	(3)	(4)	(5)	(6)	(7)	(8)	(9)	(10)	(11)	(12)	(13)	(14)	(15)	(16)	(17)	(18)	(19)
59	106.0	224.1	40.28	32.93	4.48	5,680	6,530	.00580	.00504	9,980	80.7	70.2	26.9	23.4	.000116	0.1611	1390	0.97
68	125.1	252.2	40.50	32.31	3.95	6,330	7,280	.00510	.00444	8,790	71.0	61.8	23.7	20.6	.000114	.1620	1420	0.99
77	146.6	280.2	40.70	31.69	3.52	6,960	8,000	.00455	.00396	7,840	63.3	55.1	21.1	18.4	.000111	.1628	1470	1.02
86	170.8	308.3	40.90	31.05	3.15	7,610	8,750	.00408	.00355	7,630	56.8	49.4	18.9	16.5	.000109	.1636	1500	1.04
95	197.8	336.2	41.07	30.41	2.85	8,240	9,480	.00369	.00321	6,360	51.4	44.7	17.1	14.9	.000107	.1643	1540	1.07
104	227.8	364.0	41.23	29.75	2.59	8,870	10,200	.00335	.00292	5,780	46.6	40.6	15.5	13.5	.000105	.1649	1570	1.09



As regards the measurement of consumption, the programme will not have any special rules in cases where only the measurement of steam and cooling water is undertaken, as will be mainly the case for trials of absorption-machines. For compression-machines the steam consumption depends both on the quality of the steam-engine and on that of the refrigerating-machine, while it is evidently desirable to know the consumption of the former separately from that of the latter. As a rule steam-engine and compressor are coupled directly together, thus rendering a direct measurement of the power absorbed by the refrigerating-machine impossible, and it will have to suffice to ascertain the indicated work both of steam-engine and compressor. By further measuring the work for the engine running empty, and by comparing the differences in power between steam-engine and compressor resulting for wide variations of condenser-pressures, the effective consumption of work  $L_e$  for the refrigerating-machine can be found very closely. In general, it will suffice to use the indicated work found in the steam-cylinder, especially as from this observation the expenditure of heat can be directly determined. Ordinarily the use of the indicated work in the compressor-cylinder, for purposes of comparison, should be avoided; firstly, because there are usually certain accessory apparatus to be driven (agitators, etc.), belonging to the refrigerating-machine proper; and secondly, because the external friction would be excluded.

**Report of Test.**—Reports intended to be used for comparison with the figures found for other machines will have to embrace at least the following observations:

*Refrigerator:*

- Quantity of brine circulated per hour .....
- Brine temperature at inlet to refrigerator .....
- Brine temperature at outlet of refrigerator.....  $T$
- Specific gravity of brine (at 64° Fahr.).....
- Specific heat of brine.....
- Heat abstracted (cold produced).....  $Q_e$
- Absolute pressure in the refrigerator.....

*Condenser:*

- Quantity of cooling water per hour.....
- Temperature at inlet to condenser.....
- Temperature at outlet of condenser.....  $T_c$
- Heat abstracted .....
- Absolute pressure in the condenser.....
- Temperature of gases entering the condenser.....

ABSORPTION-MACHINE.

*Still:*

- Steam consumed per hour.....
- Abs. pressure of heating steam. ....
- Temperature of condensed steam at outlet .....
- Heat imparted to still.....  $Q'_e$

*Absorber:*

- Quantity of cooling water per hour..
- Temperature at inlet .....
- Temperature at outlet .....
- Heat removed.....  $Q_2$

*Pump for Ammonia Liquor:*

- Indicated work of steam-engine ....
- Steam-consumption for pump .....
- Thermal equivalent for work of pump .....
- Total sum of losses by radiation and convection.....  $\pm Q_3$

*Heat Balance:*

$$Q_e + Q'_e = Q_1 + Q_2 \pm Q_3.$$

For the calculation of efficiency and for comparison of various tests, the actual efficiencies must be compared with the theoretical maximum of efficiency  $Q \div (AL)$  max. =  $T \div (T_c - T)$  corresponding to the temperature range.

COMPRESSION-MACHINE.

*Compressor:*

- Indicated work.....  $L_t$
- Temperature of gases at inlet
- Temperature of gases at exit

*Steam-engine:*

- Feed-water per hour.....
- Temperature of feed-water ..
- Absolute steam-pressure before steam-engine .....
- Indicated work of steam-engine .....
- Condensing water per hour...
- Temperature of do.....
- Total sum of losses by radiation and convection..  $\pm Q_3$

*Heat Balance:*

$$Q_e + AL_c = Q_1 \pm Q_3.$$

**Heat Balance.** — We possess an important aid for checking the correctness of the results found in each trial by forming the balance in each case for the heat received and rejected. Only those tests should be regarded as correct beyond doubt which show a sufficient conformity in the heat balance. It is true that in certain instances it may not be easy to account fully for the transmission of heat between the several parts of the machine and its environment by radiation and convection, but generally (particularly for compression-machines) it will be possible to obtain for the heat received and rejected a balance exhibiting small discrepancies only.

**Temperature Range.** — For the temperatures ( $T$  and  $T_c$ ) at which the heat is abstracted in the refrigerator and imparted to the condenser, it is correct to select the temperature of the brine leaving the refrigerator and that of the cooling water leaving the condenser, because it is in principle impossible to keep the refrigerator pressure higher than would correspond to the lowest brine temperature, or to reduce the condenser pressure below that corresponding to the outlet temperature of the cooling water.

Prof. Linde shows that the *maximum theoretical efficiency* of a compression-machine may be expressed by the formula

$$Q \div (AL) = T \div (T_c - T),$$

in which  $Q$  = quantity of heat abstracted (cold produced);

$AL$  = thermal equivalent of the mechanical work expended;

$L$  = the mechanical work, and  $A = 1 \div 778$ ;

$T$  = absolute temperature of heat abstraction (refrigerator);

$T_c$  = absolute temperature of heat rejection (condenser).

If  $u$  = ratio between the heat equivalent of the mechanical work  $AL$  and the quantity of heat  $Q'$  which must be imparted to the motor to produce the work  $L$ , then

$$AL \div Q' = u, \text{ and } Q'/Q = (T_c - T) \div (uT).$$

It follows that the expenditure of heat  $Q'$  necessary for the production of the quantity of cold  $Q$  in a compression-machine will be the smaller, the smaller the difference of temperature  $T_c - T$ .

**Metering the Ammonia.** — For a complete test of an ammonia refrigerating-machine it is advisable to measure the quantity of ammonia circulated, as was done in the test of the 75-ton machine described by Prof. Denton. (*Trans. A. S. M. E.*, xii, 326.)

**ACTUAL PERFORMANCES OF ICE-MAKING MACHINES.**

The table given on page 1360 is abridged from Denton, Jacobus, and Riesenberger's translation of Ledoux on Ice-making Machines. The following shows the class and size of the machines tested, referred to by letters in the table, with the names of the authorities:

Class of Machines.	Authority.	Dimensions of Compression-cylinder in inches.	
		Bore.	Stroke.
A. Ammonia cold-compression.....	Schröter.	9.9	16.5
B. Pictet fluid dry-compression .....	"	11.3	24.4
C. Bell-Coleman air.....	"	28.0	23.8
D. Closed cycle air.....	{ Renwick & Jacobus.	10.0	18.0
E. Ammonia dry-compression.....	Denton.	12.0	30.0
F. Ammonia absorption .....	"		

In class A, a German double-acting machine with compression cylinder 9.9 in. bore, 16 in. stroke, tested by Prof. Schröter, the ice-melting capacity ranges from 46.29 to 16.14 lbs. of ice per pound of coal, according as the suction pressure varies from about 45 to 8 lbs. above the atmosphere, this pressure being the condition which mainly controls the economy of compression machines. These results are equivalent to realizing from 72% to 57% of theoretically perfect performances. The higher per cents appear to occur with the higher suction-pressures, indicating a greater loss from cylinder-heating (a phenomenon the reverse of cylinder conden-

# 1360 ICE-MAKING OR REFRIGERATING-MACHINES.

sation in steam-engines), as the range of the temperature of the gas in the compression-cylinder is greater.

In E, an American single-acting compression-machine, two compression cylinders each 12 × 30 in., operating on the "dry system," tested by Prof. Denton, the percentage of theoretical effect realized ranges from 69.5% to 62.6%. The friction losses are higher for the American machine. The latter's higher efficiency may be attributed, therefore, to more perfect displacement.

The largest "ice-melting capacity" in the American machine is 24.16 lbs.

## Actual Performance of Ice-making Machines.

Machine.	Number of Test.	Absolute Pressure, in lbs. per square inch.		Temperature corresponding to Pressure, in degrees Fahr.		Temperature of Brine, in degrees Fahr.		Revolutions per minute.	Horse-power of Steam-cylinder.	Per cent of Indicated Power of Steam-cylinder lost in Friction.	Ice-melting Capacity, in tons per 24 hours.	Ice-melting Capacity, in pounds per pound of Coal. Actual.†	Diff. between theoretical Ice-melting Capacity, no Cylinder Heating or Friction, and actual, % ‡	Heat losses. Per cent of Theoretical Amount with Friction.§	Mean Effective Pressure, in lbs. per square inch
		Condenser.	Suction.	Condenser.	Suction.	Inlet.	Outlet.								
A	1	135	55	72	27	43	37	44.9	17.9	14.4	26.2	40.63	30.8	19.1	54.8
"	2	131	42	70	14	28	23	45.1	18.0	16.7	19.5	30.01	33.5	20.2	53.4
"	3	128	30	69	1	14	9	45.1	16.8	16.0	13.3	22.03	37.1	25.2	50.3
"	4	126	22	68	-12	30	-5	44.8	15.5	19.5	9.0	16.14	42.9	29.1	44.7
"	5	200	42	95	14	28	23	45.0	24.1	10.5	16.5	19.07	36.0	28.5	77.0
"	6	136	60	72	30	44	37	45.2	17.9	10.7	29.8	46.29	28.5	19.9	56.8
"	7	131	45	71	18	28	23	45.1	18.0	12.1	21.6	33.23	31.3	21.9	56.4
"	8	126	24	68	-9	0	-6	44.7	15.6	18.0	9.9	17.55	41.1	28.3	46.1
"	9	117	41	64	13	28	23	45.0	16.4	13.5	20.0	33.77	33.1	22.9	50.6
"	10	130	60	70	31	43	37	31.7	12.0	14.8	19.5	45.01	35.2	23.8	52.0
B	11	57	21	77	28	43	37	57.0	21.5	22.9	25.6	33.07	39.9	22.2	24.1
"	12	56	15	76	14	28	23	56.8	20.6	22.9	17.9	24.11	41.3	24.0	23.1
"	13	55	10	75	-2	14	9	57.1	18.5	24.0	11.6	17.47	42.2	25.2	20.4
"	14	60	7	81	-16	0	-6	57.6	15.7	25.7	5.7	10.14	54.5	38.5	16.8
"	15	91	15	104	14	28	23	59.3	27.2	16.9	15.7	16.05	36.2	23.1	31.5
"	16	61	22	81	31	44	37	57.3	21.6	14.0	28.1	36.19	33.4	22.5	26.8
"	17	59	16	80	16	28	23	57.5	20.5	12.8	19.3	26.24	34.6	25.0	25.6
"	18	59	7	79	-16	0	-6	57.8	15.9	21.1	6.8	11.93	47.5	33.4	18.0
"	19	54	22	75	31	43	37	35.3	12.4	22.3	17.0	38.04	39.5	22.6	22.6
"	20	89	16	103	16	28	23	42.9	19.9	14.7	11.9	16.68	37.7	27.0	32.7
"	21	62	6	82	-17	0	-5	34.8	9.9	24.3	3.5	9.86	54.2	39.5	17.7
C	22	59	15	65*	-53*	....	....	63.2	83.2	21.9	10.3	3.42	71.7	56.9	26.6
D	23	175	54	81*	-40*	....	....	93.4	38.1	32.1	4.9	3.0	80.0	63.0	89.2
E	24	166	43	84	15	37	28	58.1	85.0	22.7	73.9	24.16	32.8	11.7	65.9
"	25	167	23	85	-11	6	2	57.7	72.6	18.6	37.9	14.52	37.4	22.7	57.6
"	26	162	28	83	-3	14	2	57.9	73.6	19.3	46.5	17.55	34.9	18.6	59.9
"	27	176	42	88	14	36	28	58.9	88.6	19.7	74.4	23.31	30.5	13.5	70.5
F	28	152	40	79	13	21	16	....	....	....	42.2	20.1	47.8	....	....

\* Temperature of air at entrance and exit of expansion-cylinder.

† On a basis of 3 lbs. of coal per hour per H.P. of steam-cylinder of compression-machine and an evaporation of 11.1 lbs. of water per pound of combustible from and at 212° F. in the absorption-machine.

‡ Per cent of theoretical with no friction.

§ Loss due to heating during aspiration of gas in the compression-cylinder and to radiation and superheating at brine-tank.

|| Actual, including resistance due to inlet and exit valves.



This corresponds to the highest suction-pressures used in American practice for such refrigeration as is required in beer-storage cellars using the direct-expansion system. The conditions most nearly corresponding to American brewery practice in the German tests are those in line 5, which give an "ice-melting capacity" of 19.07 lbs.

For the manufacture of artificial ice, the conditions of practice are those of lines 3 and 4, and lines 25 and 26. In the former the condensing pressure used requires more expense for cooling water than is common in American practice. The ice-melting capacity is therefore greater in the German machine, being 22.03 and 16.14 lbs. against 17.55 and 14.52 for the American apparatus.

CLASS B. Sulphur Dioxide or Pictet Machines. — No records are available for determination of the "ice-melting capacity" of machines using pure sulphur dioxide. In the "Pictet fluid," a mixture of about 97% of sulphur dioxide and 3% of carbonic acid, the presence of the carbonic acid affords a temperature about 14 Fahr. degrees lower than is obtained with pure sulphur dioxide at atmospheric pressure. The latent heat of this mixture has never been determined, but is assumed to be equal to that of pure sulphur dioxide.

For brewery refrigerating conditions, line 17, we have 26.24 lbs. "ice-melting capacity," and for ice-making conditions, line 13, the "ice-melting capacity" is 17.47 lbs. These figures are practically as economical as those for ammonia, the per cent of theoretical effect realized ranging from 65.4 to 57.8. At extremely low temperatures, - 15° Fahr., lines 14 and 18, the per cent realized is as low as 42.5.

**Performance of a 75-ton Ammonia Compression-machine.** (J. E. Denton, *Trans. A. S. M. E.*, xii, 326.)—The machine had two single-acting compression cylinders 12 × 30 in., and one Corliss steam-cylinder, double-acting, 18 × 36 in. It was rated by the manufacturers as a 50-ton machine, but it showed 75 tons of ice-refrigerating effect per 24 hours during the test.

The most probable figures of performance in eight trials are as follows:

No. of Trials.	Ammonia Pressures, lbs. above Atmosphere.		Brine Temperatures, Degrees F.		Capacity Tons Refrigerating Effect per 24 hours.	Efficiency lbs. of Ice per lb. of Coal at 3 lbs. Coal per hour per H.P.	Water-consumption, gals. of Water per min. per ton of Capacity.	Ratio of Actual Weights of Ammonia circulated.	Ratio of Capacities.
	Con-densing	Suc-tion.	Inlet.	Outlet.					
1	151	28	36.76	28.86	70.3	22.60	0.80	1.0	1.0
8	161	27.5	36.36	28.45	70.1	22.27	1.09	1.0	1.0
7	147	13.0	14.29	2.29	42.0	16.27	0.83	1.70	1.60
4	152	8.2	6.27	2.03	36.43	14.10	1.1	1.93	1.92
6	105	7.6	6.40	-2.22	37.20	17.00	2.00	1.91	1.88
2	135	15.7	4.62	3.22	27.2	13.20	1.25	2.59	2.57

The principal results in four tests are given in the table on page 1363. The fuel economy under different conditions of operation is shown in the following table:

Condensing Pressure, lbs.	Suction-pressure, lbs.	Pounds of Ice-melting Effect with Engines —						B.T.U. per lb. of Steam with Engines —		
		Non-con-densing.		Non-com-pound Con-densing.		Compound Con-densing.		Non-con-dens-ing.	Con-densing.	Compound Con-densing.
		Per lb. Coal.	Per lb. Steam.	Per lb. Coal.	Per lb. Steam.	Per lb. Coal.	Per lb. Steam.			
150	28	24	2.90	30	3.61	37.5	4.51	393	513	640
150	7	14	1.69	17.5	2.11	21.5	2.58	240	300	366
105	28	34.5	4.16	43	5.18	54	6.50	591	725	923
105	7	22	2.65	27.5	3.31	34.5	4.16	376	470	591

The non-condensing engine is assumed to require 25 lbs. of steam per I.H.P. per hour, the non-compound condensing 20 lbs., and the compound condensing 16 lbs., and the boiler efficiency is assumed at 8.3 lbs. of water per lb. coal under working conditions. The following conclusions were derived from the investigation:

1. The capacity of the machine is proportional, almost entirely, to the weight of ammonia circulated. This weight depends on the suction-pressure and the displacement of the compressor-pumps. The practical suction-pressures range from 7 lbs. above the atmosphere, with which a temperature of 0° F. can be produced, to 28 lbs. above the atmosphere, with which the temperatures of refrigeration are confined to about 28° F. At the lower pressure only about one-half as much weight of ammonia can be circulated as at the upper pressure, the proportion being about in accordance with the ratios of the absolute pressures, 22 and 42 lbs. respectively. For each cubic foot of piston-displacement per minute a capacity of about one-sixth of a ton of refrigerating effect per 24 hours can be produced at the lower pressure, and of about one-third of a ton at the upper pressure. No other elements practically affect the capacity of a machine, provided the cooling-surface in the brine-tank or other space to be cooled is equal to about 36 sq. ft. per ton of capacity at 28 lbs. back pressure. For example, a difference of 100% in the rate of circulation of brine, while producing a proportional difference in the range of temperature of the latter, made no practical difference in capacity.

The brine-tank was  $10\frac{1}{2} \times 13 \times 10\frac{2}{3}$  ft., and contained 8000 lineal feet of 1-in. pipe as cooling-surface. The condensing-tank was  $12 \times 10 \times 10$  ft., and contained 5000 lineal feet of 1-in. pipe as cooling-surface.

2. The economy in coal-consumption depends mainly upon both the suction-pressures and condensing-pressures. Maximum economy with a given type of engine, where water must be bought at average city prices, is obtained at 28 lbs. suction-pressure and about 150 lbs. condensing-pressure. Under these conditions, for a non-condensing steam-engine consuming coal at the rate of 3 lbs. per hour per I.H.P. of steam-cylinders, 24 lbs. of ice-refrigerating effect are obtained per lb. of coal consumed. For the same condensing-pressure, and with 7 lbs. suction-pressure, which affords temperatures of 0° F., the possible economy falls to about 14 lbs. of refrigerating effect per lb. of coal consumed. The condensing-pressure is determined by the amount of condensing-water supplied to liquefy the ammonia in the condenser. If the latter is about 1 gallon per minute per ton of refrigerating effect per 24 hours, a condensing-pressure of 150 lbs. results, if the initial temperature of the water is about 56° F. Twenty-five per cent less water causes the condensing-pressure to increase to 190 lbs. The work of compression is thereby increased about 20%, and the resulting "economy" is reduced to about 18 lbs. of "ice effect" per lb. of coal at 28 lbs. suction-pressure and 11.5 at 7 lbs. If, on the other hand, the supply of water is made 3 gallons per minute, the condensing-pressure may be confined to about 105 lbs. The work of compression is thereby reduced about 25%, and a proportional increase of economy results. Minor alterations of economy depend on the initial temperature of the condensing-water and variations of latent heat, but these are confined within about 5% of the gross result, the main element of control being the work of compression, as affected by the back pressure and condensing-pressure, or both. If the steam-engine supplying the motive power may use a condenser to secure a vacuum, an increase of economy of 25% is available over the above figures, making the lbs. of "ice effect" per lb. of coal for 150 lbs. condensing-pressure and 28 lbs. suction-pressure 30.0, and for 7 lbs. suction-pressure, 17.5. It is, however, impracticable to use a condenser in cities where water is bought. The latter must be practically free of cost to be available for this purpose. In this case it may be assumed that water will also be available for condensing the ammonia to obtain as low a condensing-pressure as about 100 lbs., and the economy of the refrigerating-machine becomes, for 28 lbs. back pressure, 43.0 lbs. of "ice-effect" per lb. of coal, or for 7 lbs. back pressure 27.5 lbs. of ice effect per lb. of coal. If a compound condensing-engine can be used with a steam-consumption per hour per horse-power of 16 lbs. of water, the economy of the refrigerating-machine may be 25% higher than the figures last named, making for 28 lbs. back pressure a refrigerating-effect of 54.0 lbs. per lb. of coal, and for 7 lbs. back pressure a refrigerating effect of 34.0 lbs. per lb. of coal.

Performance of a 75-ton Refrigerating-machine. (Denton.)

	Maximum Capacity and Economy at 28 lbs. Back Pressure.	Maximum Capacity and Economy at Zero, Brine, and 8 lbs. Back Pressure.	Maximum Capacity and Economy for Zero, Brine, 13 lbs. Back Pressure.	Maximum Capacity and Economy at 27.5 lbs. Back Pressure.
Av. high ammonia press. above atmos.....	151 lbs.	152 lbs.	147 lbs.	161 lbs.
Av. back ammonia press. above atmos.....	28 "	8.2 "	13 "	27.5 "
Av. temperature brine inlet.....	36.76°	6.27°	14.29°	.....
Av. temperature brine outlet.....	28.86°	2.03°	2.29°	28.45°
Av. range of temperature.....	7.9°	4.24°	12.00°	7.91°
Lbs. of brine circulated per minute.....	2281	2173	943	2374
Av. temp. condensing-water at inlet.....	44.65°	56.65°	46.9°	54.00°
Av. temp. condensing-water at outlet.....	83.66°	85.4°	85.46°	82.86°
Av. range of temperature.....	39.01°	28.75°	38.56°	28.80°
Lbs. water circulated p. min. thro' cond'ser	442	315	257	601.5
Lbs. water per min. through jackets.....	25	44	40	14
Range of temperature in jackets.....	24.0°	16.2°	16.4°	29.1°
Lbs. ammonia circulated per min.....	*28.17	14.68	16.67	28.32
Probable temperature of liquid ammonia, entrance to brine-tank.....	*71.3°	*68°	*63.7°	76.7°
Temp. of amm. corresp. to av. back press.	+14°	-8°	-5°	14°
Av. temperature of gas leaving brine-tanks	34.2°	14.7°	3.0°	29.2°
Temperature of gas entering compressor....	*39°	25°	10.13°	34°
Av. temperature of gas leaving compressor	213°	263°	239°	221°
Av. temp. of gas entering condenser.....	200°	218°	209°	168°
Temperature due to condensing pressure... Heat given ammonia:	84.5°	84.0°	82.5°	88.0°
By brine, B.T.U. per minute.....	14776	7186	8824	14647
By compressor, B.T.U. per minute.....	2786	2320	2518	3020
By atmosphere, B.T.U. per minute.....	140	147	167	141
Total heat rec. by amm., B.T.U. per min....	17702	9653	11409	17708
Heat taken from ammonia:				
By condenser, B.T.U. per min.....	17242	9056	9910	17359
By jackets, B.T.U. per min.....	608	712	656	406
By atmosphere, B.T.U. per min.....	182	338	250	252
Total heat rej. by amm., B.T.U. per min....	18032	10106	10816	18017
Dif. of heat rec'd and rej., B.T.U. per min...	330	453	407	309
% work of compression removed by jackets	22%	31%	26%	13%
Av. revolutions per min.....	58.09	57.7	57.88	58.89
Mean eff. press. steam-cyl., lbs. per sq. in...	32.5	27.17	27.83	32.97
Mean eff. press. amm.-cyl., lbs. per sq. in...	65.9	53.3	59.86	70.54
Av. H.P. steam-cylinder.....	85.0	71.7	73.6	88.63
Av. H.P. ammonia-cylinder.....	65.7	54.7	59.37	71.20
Friction in per cent of steam H.P.....	23.0	24.0	20.0	19.67
Total cooling water, gallons per min. per ton per 24 hours.....	0.75	1.185	0.797	0.990
Tons ice-melting capacity per 24 hours.....	74.8	36.43	44.64	74.56
Lbs. ice-refrigerating eff. per lb. coal at 3 lbs. per H.P. per hour.....	24.1	14.1	17.27	23.37
Cost coal per ton of ice-refrigerating effect at \$4 per ton.....	\$0.166	\$0.283	\$0.231	\$0.170
Cost water per ton of ice-refrigerating effect at \$1 per 1000 cu.ft.....	\$0.128	\$0.200	\$0.136	\$0.169
Total cost of 1 ton of ice-refrigerating eff...	\$0.294	\$0.483	\$0.467	\$0.339

Figures marked thus (\*) are obtained by calculation; all other figures obtained from experimental data; temperatures in Fahrenheit are degrees



## Ammonia Compression-machine.

ACTUAL RESULTS OBTAINED AT THE MUNICH TESTS.

(Prof. Linde, *Trans. A. S. M. E.*, xiv, 1419.)

No. of Test .....	1	2	3	4	5	
Temp. of refrigerated brine	Inlet, deg. F....	43.194	28.344	13.952	-0.279	28.251
	Outlet, deg. F....	37.054	22.885	8.771	-5.879	23.072
Specific heat of brine.....	0.861	0.851	0.843	0.837	0.851	
Brine circ. per hour, cu. ft.....	1,039.38	908.84	633.89	414.98	800.93	
Cold produced, B.T.U. per hour...	342,909	263,950	172,776	121,474	220,284	
Cooling water per hour, cu. ft....	338.76	260.83	187.506	139.99	97.76	
I.H.P. in steam-engine cylinder...	15.80	16.47	15.28	14.24	21.61	
Cold produced per	Per I.H.P. in comp.-cyl	24,813	18,471	12,770	10,140	11,151
	Per I.H.P. in steam-cyl	21,703	16,026	11,307	8,530	10,194
	Per lb. of steam.....	1,100.8	785.6	564.9	435.82	512.12

A test of a 35-ton absorption-machine in New Haven, Conn., by Prof. Denton (*Trans. A. S. M. E.*, x, 792), gave an ice-melting effect of 20.1 lbs. per lb. of coal on a basis of boiler economy equivalent to 3 lbs. of steam per I.H.P. in a good non-condensing steam-engine. The ammonia was worked between 138 and 23 lbs. pressure above the atmosphere.

**Performance of a Single-acting Ammonia Compressor.**—Tests were made at the works of the Eastman Kodak Co., Rochester, N.Y., of a machine fitted with two York Mfg. Co.'s single-acting compressors, 15 in. diam., 22 in. stroke, to determine the horse-power per ton of refrigeration. Following are the principal average results (Bulletin of York Mfg. Co.):

Date of Test, 1908.....	Mar. 6	Mar. 7	Mar. 8	Mar. 9	Mar. 10.	Mar. 11.	Mar. 14.
Temp. dischg. gas, av. ....	216.2	217.8	250.6	245.8	253.0	242.9	255.5
Temp. suction gas, av. ....	15.2	14.3	16.8	14.8	13.5	18.2	17.9
Temp. suction at cooler..	9.33	9.36	10.37	9.29	9.90	13.20	9.13
Temp. liquid at exp. valve	74.85	74.16	71.98	77.91	76.61	82.88	76.98
Temp. brine, inlet.....	22.89	23.19	25.26	22.73	27.35	28.41	23.43
Temp. brine, outlet .....	13.58	13.96	14.44	13.02	15.53	16.06	12.87
Revs. per min.....	45.1	45.0	45.1	34.3	56.0	67.8	44.8
Lbs. liquid NH <sub>3</sub> per min..	20.76	20.43	21.04	15.59	25.99	.....	20.40
Suc. press. at mach. lb. ...	20.11	19.90	19.97	20.04	20.18	18.13	20.38
Condenser pressure.....	183.96	184.41	186.99	187.27	187.90	186.8	183.81
Indicated H.P.....	69.35	69.80	70.05	52.57	89.48	105.11	68.61
Tons Refrig. Capy, 24 hrs.	49.08	48.79	50.38	37.01	61.39	66.65	49.31
I.H.P. per ton capacity ..	1.418	1.427	1.389	1.422	1.425	1.439	1.375

Full details of these tests were reported to the Am. Socy. of Refrig. Engrs. and published in *Ice and Refrigeration*, 1908.

**Performance of Absorption Machines.**—From an elaborate review by Mr. Voorhees of the action of an absorption machine under certain stated conditions, showing the quantity of ammonia circulated per hour per ton of refrigeration, its temperature, etc., at the several stages of the operation, and its course through the several parts of the apparatus, the following condensed statement is obtained:

Generator. — 30.9 lbs. dry steam, 38 lbs. gauge pressure condensed, evaporates 32.2% strong liquor to 22.3% weak liquor.

Exchanger. — 3.01 lbs. weak liquor at 264° cools to 111°.

Absorber. — Adds 0.43 lbs. vapor from the brine cooler, making 3.44 lbs. strong liquor at 111° to go to the pump.

Exchanger. — 3.44 lbs. heated to 224°, some of it is now gas, and the rest liquor of a little less than 32% NH<sub>3</sub>.

Analyser. — (A series of shelves in a tank above the generator) delivers strong liquor to the generator, while the vapor, 91% NH<sub>3</sub>, 0.4982 lb., goes to the rectifier.

Rectifier. — Cools the gas to 110° separating water vapor as 0.0682 lb. drip liquor which returns through a trap to the generator.

Condenser. — 0.43 lb. NH<sub>3</sub> gas at 110° cooled and condensed to liquid at 90° by 2 gals. of water per min. heated from 73° to 86°.

Expansion Valve and Cooler. — Reduces liquid to 0° and boils it at 0°, cooling 3 gals. of brine per min. from 12° to 3°. Gas passes to absorber and the cycle is repeated.

Of the 2 gals. per min. of cooling water flowing from the condenser, 0.2 gal. goes to the rectifier, where it is heated to 142°, and 1.8 gal. through the absorber, where it is heated to 110°.

Heat Balance. — Absorbed in the generator 496; in the brine cooler, 200, Total 696 B.T.U. Rejected; condenser, 220; absorber, 383; rectifier, 93; Total 696 B.T.U.

The following table shows the strength of the liquors and the quantity of steam required per hour per ton of refrigeration under the conditions stated:

Condenser Pressures.

	140			170			200		
	Suction Pressures.								
	0	15	30	0	15	30	0	15	30
Sl per cent. . . . .	24	35	42	22	32	38	18	28	36
Wl per cent. . . . .	13.13	25.75	33.70	10.85	22.3	29.15	6.28	17.7	26.9
SG, pounds. . . . .	30.1	27.9	22.9	41.3	30.9	26.2	48.7	34.1	27.9
SL, pounds. . . . .	1.7	1.6	1.4	2.1	1.9	1.8	2.4	2.3	2.2

Sl, strong liquor; Wl, weak liquor; SG, lbs. of steam per hour per ton of refrigeration for the generator, SL, do. for the liquor pump. Pressures are in lbs. per sq. in., gauge.

The following table gives the steam consumption in lbs. per hour per ton of refrigeration, for engine-driven compressors and for absorption machines with liquor pump not exhausting into the generator at the suction and condenser pressures (gauge) given: SC, simple non-condensing engine, CC, compound condensing engine, A, absorption machine.

Condenser Pressures.

	140			170			200		
	Suction Pressures.								
	0	15	30	0	15	30	0	15	30
SC. . . . .	78.3	44.5	31.1	90.5	52.5	37.2	104.0	61.4	44.5
CC. . . . .	42.0	23.8	16.6	48.4	28.0	19.0	55.6	32.7	23.9
A. . . . .	31.8	29.5	24.3	43.4	32.8	28.0	51.1	36.4	30.1

The economy of the absorption machine is much better for all conditions than that of a simple non-condensing engine-driven compressor. At suction gauge pressures above 8 to 10 lbs. the economy of the compound condensing engine-driven compressor exceeds that of the absorption machine, the absorption machine giving the superior economy at suction pressures below 8 to 10 lbs.

**Means for Applying the Cold.** (M. C. Bannister, Liverpool Eng'g Soc'y, 1890.) — The most useful means for applying the cold to various uses is a saturated solution of brine or chloride of magnesium, which remains liquid at 5° Fahr. The brine is first cooled by being circulated in contact with the refrigerator-tubes, and then distributed through coils of pipes, arranged either in the substances requiring a reduction of temperature, or in the cold stores or rooms prepared for them; the air coming in contact with the cold tubes is immediately chilled, and the moisture in the air deposited on the pipes. It then falls, making room for warmer air, and so circulates until the whole room is at the temperature of the brine in the pipes.

**The Direct Expansion Method** consists in conveying the compressed cooled ammonia (or other refrigerating agent) directly to the room to be cooled, and then expanding it through an expansion cock into pipes in the room. Advantages of this system are its simplicity and its rapidity of

action in cooling a room; disadvantages are the danger of leakage of the gas and the fact that the machine cannot be stopped without a rapid rise in the temperature of the room. With the brine system, with a large amount of cold brine in the tank, the machine may be stopped for a considerable time without serious cooling of the room.

*Air has also been used* as the circulating medium. The ammonia-pipes refrigerate the air in a cooling-chamber, and large conduits are used to convey it to and return it from the rooms to be cooled. An advantage of this system is that by it a room may be refrigerated more quickly than by brine-coils. The returning air deposits its moisture on the ammonia-pipes, in the form of snow, which is removed by mechanical brushes.

### ARTIFICIAL-ICE MANUFACTURE.

Under summer conditions, with condensing water at 70°, artificial-ice machines use ammonia at a condenser pressure, about 190 lbs. above the atmosphere and 15 lbs. suction-pressure.

In a compression type of machine the useful circulation of ammonia, allowing for the effect of cylinder-heating, is about 13 lbs. per hour per indicated horse-power of the steam-cylinder. This weight of ammonia produces about 32 lbs. of ice at 15° from water at 70°. If the ice is made from distilled water, as in the "can system," the amount of the latter supplied by the boilers is about 33% greater than the weight of ice obtained. This excess represents steam escaping to the atmosphere from the re-boiler and steam-condenser, to purify the distilled water, or free it from air; also, the loss through leaks and drips, and loss by melting of the ice in extracting it from the cans. The total steam consumed per horse-power is, therefore, about  $32 \times 1.33 = 43.0$  lbs. About 7.0 lbs. of this covers the steam-consumption of the steam-engines driving the brine circulating-pumps, the several cold-water pumps, and leakage, drips, etc. Consequently, the main steam-engine must consume 36 lbs. of steam per hour per I.H.P., or else live steam must be condensed to supply the required amount of distilled water. There is, therefore, nothing to be gained by using steam at high rates of expansion in the steam-engines, in making artificial ice from distilled water. If the cooling water for the ammonia-coils and steam-condenser is not too hard for use in the boilers, it may enter the latter at about 175° F., by restricting the quantity to 1½ gallons per minute per ton of ice. With good coal 8½ lbs. of feed-water may then be evaporated, on the average, per lb. of coal.

The ice made per pound of coal will then be  $32 \div (43.0 \div 8.5) = 6.0$  lbs. This corresponds with the results of average practice.

If ice is manufactured by the "plate system," no distilled water is used for freezing. Hence the water evaporated by the boiler may be reduced to the amount which will drive the steam-motors, and the latter may use steam expansively to any extent consistent with the power required to compress the ammonia, operate the feed and filter pumps, and the hoisting machinery. The latter may require about 15% of the power needed for compressing the ammonia.

If a compound condensing steam-engine is used for driving the compressors, the steam per indicated steam horse-power, or per 32 lbs. of net ice, may be 14 lbs. per hour. The other motors at 50 lbs. of steam per horse-power will use 7.5 lbs. per hour, making the total consumption per steam horse-power of the compressor 21.5 lbs. Taking the evaporation at 8 lbs., the feed-water temperature being limited to about 110°, the coal per horse-power is 2.7 lbs. per hour. The net ice per lb. of coal is then about  $32 \div 2.7 = 11.8$  lbs. The best results with "plate-system" plants, using a compound steam-engine, have thus far afforded about 10½ lbs. of ice per lb. of coal.

In the "plate system" the ice gradually forms, in from 8 to 10 days, to a thickness of about 14 inches, on the hollow plates, 10 × 14 feet in area, in which the cooling fluid circulates.

In the "can system" the water is frozen in blocks weighing about 300 lbs. each, and the freezing is completed in from 40 to 48 hours. The freezing-tank area occupied by the "plate system" is, therefore, about twelve times, and the cubic contents about four times, as much as required in the "can system."

The investment for the "plate" is about one-third greater than for the "can" system. In the latter system ice is being drawn throughout the



24 hours, and the hoisting is done by hand tackle. Some "can" plants are equipped with pneumatic hoists and on large hoists electric cranes are used to advantage. In the "plate system" the entire daily product is drawn, cut, and stored in a few hours, the hoisting being performed by power. The distribution of cost is as follows for the two systems, taking the cost for the "can" or distilled-water system as 100, which represents an actual cost of about \$1.25 per net ton:

	Can System.	Plate System.
Hoisting and storing ice .....	14.2	2.8
Engineers, firemen, and coal-passer .....	15.0	13.9
Coal at \$3.50 per gross ton .....	42.2	20.0
Water pumped directly from a natural source at 5 cts. per 1000 cubic feet .....	1.3	2.6
Interest and depreciation at 10% .....	24.6	32.7
Repairs .....	2.7	3.4
	<hr/>	<hr/>
	100.00	75.4

A compound condensing engine is assumed to be used by the "plate system."

**Test of the New York Hygeia Ice-making Plant.** — (By Messrs. Hupfel, Griswold, and Mackenzie; *Stevens Indicator*, Jan., 1894.)

The final results of the tests were as follows:

Net ice made per pound of coal, in pounds .....	7.12
Pounds of net ice per hour per horse-power .....	37.8
Net ice manufactured per day (12 hours) in tons .....	97
Av. pressure of ammonia-gas at condenser, lbs. per sq. in. above atmos. ....	135.2
Average back pressure of amm.-gas, lbs. per sq. in. above atmos. ....	15.8
Average temperature of brine in freezing-tanks, degrees F. ....	19.7
Total number of cans filled per week .....	4389
Ratio of cooling-surface of coils in brine-tank to can-surface. ....	7 to 10

**An Absorption Evaporator Ice-making System**, built by the Carbondale Machine Co. is in operation at the ice plant of the Richmond Ice Co., Clifton, Staten Island, N. Y., which produces the extra distilled water by an evaporator at practically no fuel cost, and thus about 10 tons of distilled water ice per ton of coal is obtained. Steam from the boiler at 100 lbs. pressure enters an evaporator, distilling off steam at 70 lbs., which operates the pumps and auxiliary machinery. These exhaust into the ice machine generator under 10 lbs. pressure, where the exhaust is condensed. In a 100-ton plant the evaporator will condense 43 tons of live steam, distilling off 40 tons of steam to operate the auxiliaries, which exhaust into the generator; 20 tons of live steam has to be added to this exhaust, making 60 tons in all, which is the amount required to operate the generator. The 60 tons of condensation from the generator and 43 tons from the evaporator go to the re-boiler, making 103 tons of distilled water to be frozen into ice. The total steam consumption is the 60 tons condensed in the generator plus 3 tons for radiation, or 63 tons in all. Hence if the boiler evaporates 6.6 lbs. water per pound of coal the economy of the plant will be  $10\frac{1}{2}$  lbs. ice per pound of coal, a result which cannot be obtained even with compound condensing engines and compression machines.

Heat-exchanging coils, on the order of a closed feed-water heater, are used to heat the feed-water going to the boiler. The condensation leaving the generator and evaporator at a high temperature is utilized for this purpose; by this means securing a feed-water temperature considerably in excess of  $212^{\circ}$ .

**Ice-Making with Exhaust Steam.** — The exhaust steam from electric light plants is being utilized to manufacture ice on the absorption system. A 10-ton plant at the Holdredge Lighting Co., Holdredge, Neb., built by the Carbondale Machine Co., is described in *Elec. World*, April 7, 1910. Here 11 tons of ice were made per day with exhaust steam from the electric engines at  $2\frac{1}{2}$  lbs. pressure, using  $6\frac{1}{3}$  K.W., or  $8\frac{1}{2}$  H.P., for driving the circulating pumps.

**Tons of Ice per Ton of Coal.** — From a long table by Mr. Voorhees, showing the net tons of plate ice that may be made in well-designed plants under a variety of conditions as to type of engine, the following figures are taken:

Compression, Simple Corliss engine, non-condensing.....	6.1 tons
Absorption liquor pump and auxiliaries not exhausting into generator, simple, non-condensing engine.....	10.0
Compression, compound condensing engine.....	11.2
Compression triple-expansion condensing engine.....	12.8
Absorption, pump and auxiliaries exhausting into generator, Corliss non-condensing engine.....	13.3
Compression and absorption, compound engine, non-condensing	16.0
Compression, triple-expansion condensing engine, multiple effect	16.5
Compression and absorption, triple-expansion non-condensing engine, multiple effect.....	19.5

**Standard Ice Cans or Moulds.**  
(Buffalo Refrigerating Machine Co.)

Weight of Block.	Size of Can.	Time of Freezing.	Weight of Block.	Size of Can.	Time of Freezing.
pounds		hours	pounds		hours
25	4×10×24	12	100	11×11×32	48
50	6×12×26	20	200	11×22×32	54
100	8×15×32	36	300	11×22×44	54
150	8×15×44	36	400	11×22×56	54
150	10×15×36	48	200	14×14×40	66
200	10×20×36	48			

The above given time of freezing is with a brine temperature of 15° F.

**Cubic Feet of Well-insulated Space per Ton of Refrigeration.**

(F. W. Niebling Co., Cincinnati, O.)

Room Temperature.	0° F.	5°	10°	20°	32°	36°
Size of Room.	Cubic Feet per Ton.					
Up to 1,000 cu. ft.....	200	400	800	1400	2000	2500
1,000 to 10,000 cu. ft.....	600	1200	2500	4500	6000	8000
Over 10,000 cu. ft.....	1000	2000	4000	6000	8000	10,000

## MARINE ENGINEERING.

**Rules for Measuring Dimensions and Obtaining Tonnage of Vessels.** (Record of American and Foreign Shipping. American Bureau of Shipping, N. Y., 1890.) — The dimensions to be measured as follows:

I. Length, *L*. — From the fore-side of stem to the after-side of stern-post measured at middle line on the upper deck of all vessels, except those having a continuous hurricane-deck extending right fore and aft, in which the length is to be measured on the range of deck immediately below the hurricane-deck.

Vessels having clipper heads, raking forward, or receding stems, or raking stern-posts, the length to be the distance of the fore-side of stem from aft-side of stern-post at the deep-load water-line measured at middle line. (The inner or propeller-post to be taken as stern-post in screw-steamers.)

II. Breadth, *B*. — To be measured over the widest frame at its widest part; in other words, the molded breadth.

III. Depth, *D*. — To be measured at the dead-flat frame and at middle line of vessel. It shall be the distance from the top of floor-plate to the upper side of upper deck-beam in all vessels except those having a continuous hurricane-deck, extending right fore and aft, and not intended for the American coasting trade, in which the depth is to be the distance from top of floor-plate to midway between top of hurricane deck-beam and the top of deck-beam of the deck immediately below hurricane-deck.

In vessels fitted with a continuous hurricane-deck, extending right fore and aft, and intended for the American coasting trade, the depth is

to be the distance from top of floor-plate to top of deck-beam of deck immediately below hurricane-deck.

**Rule for Obtaining Tonnage.**— Multiply together the length, breadth, and depth, and their product by 0.75; divide the last product by 100; the quotient will be the tonnage.  $L \times B \times D \times 0.75 \div 100 = \text{tonnage}$ .

**The U. S. Custom-house Tonnage Law,** May 6, 1864, provides that "the register tonnage of a vessel shall be her entire internal cubic capacity in tons of 100 cubic feet each." This measurement includes all the space between upper decks, however many there may be. Explicit directions for making the measurements are given in the law.

**The Displacement of a Vessel** (measured in tons of 2240 lbs.) is the weight of the volume of water which it displaces. For sea-water it is equal to the volume of the vessel beneath the water-line, in cubic feet, divided by 35, which figure is the number of cubic feet of sea-water at 60° F. in a ton of 2240 lbs. For fresh water the divisor is 35.93. The U. S. register tonnage will equal the displacement when the entire internal cubic capacity bears to the displacement the ratio of 100 to 35.

The displacement or gross tonnage is sometimes approximately estimated as follows: Let  $L$  denote the length in feet of the boat,  $B$  its extreme breadth in feet, and  $D$  the mean draught in feet; the product of these three dimensions will give the volume of a parallelepipedon in cubic feet. Putting  $V$  for this volume, we have  $V = L \times B \times D$ .

The volume of displacement may then be expressed as a *percentage* of the volume  $V$ , known as the "*block coefficient*." This percentage varies for different classes of ships. In racing yachts with very deep keels it varies from 22 to 33; in modern merchantmen from 55 to 90; for ordinary small boats probably 50 will give a fair estimate. The volume of displacement in cubic feet divided by 35 gives the displacement in tons.

**Coefficient of Fineness.**— A term used to express the relation between the displacement of a ship and the volume of a rectangular prism or box whose lineal dimensions are the length, breadth, and draught.

Coefficient of fineness =  $D \times 35 \div (L \times B \times W)$ ;  $D$  being the displacement in tons of 35 cubic feet of sea-water to the ton,  $L$  the length between perpendiculars,  $B$  the extreme breadth and  $W$  the mean draught, all in feet.

**Coefficient of Water-lines.**— An expression of the relation of the displacement to the volume of the prism whose section equals the midship section of the ship, and length equal to the length of the ship.

Coefficient of water-lines =  $D \times 35 \div (\text{area of immersed water section} \times L)$ . Seaton gives the following values:

	Coefficient of Fineness.	Coefficient of Water-lines
Finely-shaped ships.....	0.55	0.63
Fairly-shaped ships.....	0.61	0.67
Ordinary merchant steamers 10 to 11 knots...	0.65	0.72
Cargo steamers, 9 to 10 knots.....	0.70	0.76
Modern cargo steamers of large size.....	0.78	0.83

**Resistance of Ships.**— The resistance of a ship passing through water may vary from a number of causes, as speed, form of body, displacement, midship dimensions, character of wetted surface, fineness of lines, etc. The resistance of the water is twofold; 1st. That due to the displacement of the water at the bow and its replacement at the stern, with the consequent formation of waves. 2d. The friction between the wetted surface of the ship and the water, known as skin resistance. A common approximate formula for resistance of vessels is

$$\text{Resistance} = \text{speed}^2 \times \sqrt[3]{\text{displacement}^2} \times \text{a constant, or } R = S^2 D^{2/3} \times C.$$

If  $D_1$  = displacement in pounds,  $S_1$  = speed in feet per minute,  $R$  resistance in pounds,  $R = cS_1^2 D_1^{2/3}$ . The work done in overcoming the resistance through a distance equal to  $S_1$  is  $R \times S_1 = cS_1^3 D_1^{2/3}$ ; and if  $E$  is the efficiency of the propeller and machinery combined, the indicated horse-power I.H.P. =  $cS_1^3 D_1^{2/3} \div (E \times 33,000)$ .

If  $S$  = speed in knots,  $D$  = displacement in tons, and  $C$  a constant which includes all the constants for form of vessel, efficiency of mechanism, etc., I.H.P. =  $S^3 D^{2/3} \div C$ .

The wetted surface varies as the cube root of the square of the displacement; thus, let  $L$  be the length of edge of a cube just immersed, whose





power demanded to impel a ship is thus the product of a constant to be determined by experiment, the area of the wetted surface, the *cube* of the speed, and the quantity in the parenthesis, which is known as the "coefficient of augmentation." In calculating the resistance of ships the last term of the coefficient may be neglected as too small to be practically important. In applying the formula, the mean of the squares of the sines of the angles of maximum obliquity of the water-lines is to be taken for  $\sin^2 \theta$ , and the rule will then read thus:

To obtain the resistance of a ship of good form, in pounds, multiply the length in feet by the mean immersed girth and by the coefficient of augmentation, and then take the product of this "augmented surface," as Rankine termed it, by the square of the speed in knots, and by the proper constant coefficient selected from the following:

For clean painted vessels, iron hulls.....	$A = 0.01$
For clean coppered vessels.....	$A = 0.009$ to $0.008$
For moderately rough iron vessels.....	$A = 0.011 +$

The net, or effective, horse-power demanded will be quite closely obtained by multiplying the resistance calculated, as above, by the speed in knots and dividing by 326. The gross, or indicated, power is obtained by multiplying the last quantity by the reciprocal of the efficiency of the machinery and propeller, which usually should be about 0.6. Rankine uses as a divisor in this case 200 to 260.

The form of the vessel, even when designed by skillful and experienced naval architects, will often vary to such an extent as to cause the above constant coefficients to vary somewhat; and the range of variation with good forms is found to be from 0.8 to 1.5 the figures given.

For well-shaped iron vessels, an approximate formula for the horse-power required is  $H.P. = SV^3 \div 20,000$ , in which  $S$  is the "augmented surface." The expression  $SV^3 \div H.P.$  has been called by Rankine the *coefficient of propulsion*. In the Hudson River steamer "Mary Powell," according to Thurston, this coefficient was as high as 23,500.

The expression  $D^{\frac{2}{3}}V^3 \div H.P.$  has been called the *locomotive performance*. (See Rankine's Treatise on Shipbuilding, 1864; Thurston's Manual of the Steam-engine, part ii, p. 16; also paper by F. T. Bowles, U. S. N., Proc. U. S. Naval Institute, 1883.)

Rankine's method for calculating the resistance is said by Seaton to give more accurate and reliable results than those obtained by the older rules, but it is criticised as being difficult and inconvenient of application.

**Empirical Equations for Wetted Surface.** (Peabody, Naval Architecture, page 411).— $L$  = length, feet;  $B$  = beam;  $H$  = mean draught;  $D$  = displacement in tons;  $K$  = block coefficient.

Taylor Surface =  $C\sqrt{DL}$ . Values of  $C$  for different ratios  $B \div H$  are:

$B \div H = 2$	2.2	2.4	2.6	2.8	3.0	3.2	3.4
$C = 15.63$	15.54	15.50	15.51	15.55	15.62	15.71	15.83

Normand Surface =  $1.52 LH + (3.74 + 0.85 K^2) LB$ .

Mumford Surface =  $L(1.74 + KB)$ .

Errors of these approximate equations as applied to several types of vessels are shown by Professors Durand and McDermott (Trans. Soc. Nav. Archts. & Mar. Engrs., Vol. 2), as follows: Taylor — 2.69 to + 2.52%; Normand, — 1.55 to + 2.57%; Mumford, 0 to — 0.95%, except one lake freight vessel,  $L = 299$ ,  $B = 40.9$ ,  $D = 15.9$ ,  $K = 0.825$ , on which Mumford's formula was — 12.55% in error.

**E. R. Mumford's Method of Calculating Wetted Surfaces** is given in a paper by Archibald Denny, *Eng'g*, Sept. 21, 1894. The following is his formula, which gives closely accurate results for medium draughts, beams, and finenesses;

$$S = (L \times D \times 1.7) + (L \times B \times C),$$

in which  $S$  = wetted surface in square feet;  $L$  = length between perpendiculars in feet;  $D$  = middle draught in feet;  $B$  = beam in feet;  $C$  = block coefficient.

The formula may also be expressed in the form  $S = L(1.7D + BC)$ .

In the case of twin-screw ships having projecting shaft-casings, or in

the case of a ship having a deep keel or bilge keels, an addition must be made for such projections. The formula gives results which are in general much more accurate than those obtained by Kirk's method. It underestimates the surface when the beam, draught, or block coefficients are excessive; but the error is small except in the case of abnormal forms, such as stern-wheel steamers having very excessive beams (nearly one-fourth the length), and also very full block coefficients. The formula gives a surface about 6% too small for such forms.

The wetted surface of the block is nearly equal to that of the ship of the same length, beam and draught; usually 2% to 5% greater. In exceedingly fine hollow-line ships it may be 8% greater.

$$\text{Area of bottom of block} = (F + M) \times B;$$

$$\text{Area of sides} = 2 M \times H.$$

$$\text{Area of sides of ends} = 4 \times \sqrt{F^2 + \left(\frac{B}{2}\right)^2} \times H;$$

$$\text{Tangent of half angle of entrance} = \frac{1}{2} B/F = B/(2F).$$

From this, by a table of natural tangents, the angle of entrance may be obtained:

	Angle of Entrance of the Block Model.	Fore-body in parts of length.
Ocean-going steamers, 14 knots and upw'd	18° to 15°	0.3 to 0.36
“ “ “ 12 to 14 knots . . . .	21° to 18°	0.26 to 0.3
“ cargo steamers, 10 to 12 knots..	30° to 22°	0.22 to 0.26

**Dr. Kirk's Method.** — This method is generally used on the Clyde.

The general idea proposed by Dr. Kirk is to reduce all ships to so definite and simple a form that they may be easily compared; and the magnitude of certain features of this form shall determine the suitability of the ship for speed, etc.

The form consists of a middle body, which is a rectangular parallelepiped, and fore-body and after-body, prisms having isosceles triangles for bases, as shown in Fig. 225.

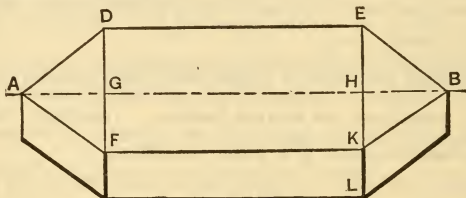

FIG. 225.

This is called a block model, and is such that its length is equal to that of the ship, the depth is equal to the mean draught, the capacity equal to the displacement volume, and its area of section equal to the area of immersed midship section. The dimensions of the block model may be obtained as follows: Let  $AG = HB =$  length of fore- or after-body  $= F$ ;  $GH =$  length of middle body  $= M$ ;  $KL =$  mean draught  $= H$ ;  $EK =$  area of immersed midship section  $\div KL = B$ . Volume of block  $= (F + M) \times B \times H$ ; midship section  $= B \times H$ ; displacement in tons  $=$  volume in cubic ft.  $\div 35$ .

$$AH = AG + GH = F + M = \text{displacement} \times 35 \div (B \times H).$$

**To find the Indicated Horse-power from the Wetted Surface.** (Seaton.) — In ordinary cases the horse-power per 100 feet of wetted surface may be found by assuming that the rate for a speed of 10 knots is 5, and that the quantity varies as the cube of the speed. For example: To find the number of I.H.P. necessary to drive a ship at a speed of 15 knots, having a wetted skin of block model of 16,200 square feet:

$$\text{The rate per 100 feet} = (15/10)^3 \times 5 = 16.875.$$

$$\text{Then I.H.P. required} = 16.875 \times 162 = 2734.$$

When the ship is exceptionally well-proportioned, the bottom quite



clean, and the efficiency of the machinery high, as low a rate as 4 I.H.P. per 100 feet of wetted skin of block model may be allowed.

The gross indicated horse-power includes the power necessary to overcome the friction and other resistance of the engine itself and the shafting, and also the power lost in the propeller. In other words, I.H.P. is no measure of the resistance of the ship, and can only be relied on as a means of deciding the size of engines for speed, so long as the efficiency of the engine and propeller is known definitely, or so long as similar engines and propellers are employed in ships to be compared. The former is difficult to obtain, and it is nearly impossible in practice to know how much of the power shown in the cylinders is employed usefully in overcoming the resistance of the ship. The following example is given to show the variation in the efficiency of propellers:

	Knots.	I.H.P.
H.M.S. "Amazon," with a 4-bladed screw, gave . . . . .	12.064	with 1940
H.M.S. "Amazon," with a 2-bladed screw, increased pitch, and fewer revolutions per minute. . . . .	12.396	" 1663
H.M.S. "Iris," with a 4-bladed screw . . . . .	16.577	" 7503
H.M.S. "Iris," with 2-bladed screw, increased pitch, fewer revolutions per knot . . . . .	18.587	" 7556

**Relative Horse-power Required for Different Speeds of Vessels.** (Horse-power for 10 knots = 1.) — The horse-power is taken usually to vary as the cube of the speed, but in different vessels and at different speeds it may vary from the 2.8 power to the 3.5 power, depending upon the lines of the vessel and upon the efficiency of the engines, the propeller, etc. (The power may vary at a much higher rate than the 3.5 power of the speed when the speed is much less than normal, and the machinery is therefore working at less than its normal efficiency.)

Speed knots.	4	6	8	10	12	14	16	18	20	22	24	26	28	30
HP $\propto$														
S <sup>2.8</sup>	.0769	.239	.535	1.	1.666	2.565	3.729	5.185	6.964	9.095	11.60	14.52	17.87	21.67
S <sup>2.9</sup>	.0701	.227	.524	1.	1.697	2.653	3.908	5.499	7.464	9.841	12.67	15.97	19.80	24.19
S <sup>3</sup>	.0640	.216	.512	1.	1.728	2.744	4.096	5.832	8.	10.65	13.82	17.58	21.95	27.
S <sup>3.1</sup>	.0584	.205	.501	1.	1.760	2.838	4.293	6.185	8.574	11.52	15.09	19.34	24.33	30.14
S <sup>3.2</sup>	.0533	.195	.490	1.	1.792	2.935	4.500	6.559	9.189	12.47	16.47	21.28	26.97	33.63
S <sup>3.3</sup>	.0486	.185	.479	1.	1.825	3.036	4.716	6.957	9.849	13.49	17.98	23.41	29.90	37.54
S <sup>3.4</sup>	.0444	.176	.468	1.	1.859	3.139	4.943	7.378	10.56	14.60	19.62	25.76	33.14	41.90
S <sup>3.5</sup>	.0405	.167	.458	1.	1.893	3.247	5.181	7.824	11.31	15.79	21.42	28.34	36.73	46.77

**EXAMPLE IN USE OF THE TABLE.**—A certain vessel makes 14 knots speed with 587 I.H.P. and 16 knots with 900 I.H.P. What I.H.P. will be required at 18 knots, the rate of increase of horse-power with increase of speed remaining constant? The first step is to find the rate of increase, thus:  $14^x : 16^x :: 587 : 900$ .

$$x \log 16 - x \log 14 = \log 900 - \log 587;$$

$$x (0.204120 - 0.146128) = 2.954243 - 2.768638,$$

whence  $x$  (the exponent of  $S$  in formula  $H.P. \propto S^x$ ) = 3.2.

From the table, for  $S^{3.2}$  and 16 knots, the I.H.P. is 4.5 times the I.H.P. at 10 knots;  $\therefore$  H.P. at 10 knots =  $900 \div 4.5 = 200$ .

From the table for  $S^{3.2}$  and 18 knots, the I.H.P. is 6.559 times the I.H.P. at 10 knots;  $\therefore$  H.P. at 18 knots =  $200 \times 6.559 = 1312$  H.P.

**Resistance per Horse-power for Different Speeds.** (One horse-power = 33,000 lbs. resistance overcome through 1 ft. in 1 min.)—The resistances per horse-power for various speeds are as follows: For a speed of 1 knot, or 6080 feet per hour =  $101\frac{1}{3}$  ft. per min.,  $33,000 \div 101\frac{1}{3} = 325.658$  lbs. per horse-power; and for any other speed  $325.658$  lbs. divided by the speed in knots; or for

1 knot	325.66 lbs.	8 knots	40.71 lbs.	15 knots	21.71 lbs.
2 knots	162.83 "	9 "	36.18 "	16 "	20.35 "
3 "	108.55 "	10 "	32.57 "	17 "	19.16 "
4 "	81.41 "	11 "	29.61 "	18 "	18.09 "
5 "	65.13 "	12 "	27.14 "	19 "	17.14 "
6 "	54.28 "	13 "	25.05 "	20 "	16.28 "
7 "	46.52 "	14 "	23.26 "		

More accurate methods than those above given for estimating the horse-power required for any proposed ship are: 1. Estimations calculated from the results of trials of "similar" vessels driven at "corresponding" speeds; "similar" vessels being those that have the same ratio or length to breadth and to draught, and the same coefficient of fineness, and "corresponding" speeds those which are proportional to the square roots of the lengths of the respective vessels. Froude found that the resistances of such vessels varied almost exactly as wetted surface  $\times$  (speed)<sup>2</sup>

2. The method employed by the British Admiralty and by some Clyde shipbuilders, viz., ascertaining the resistance of a model of the vessel, 12 to 20 ft. long, in a tank, and calculating the power from the results obtained.

**Estimated Displacement, Horse-power, etc.** — The table on the next page, calculated by the author, will be found convenient for making approximate estimates.

The figures in 7th column are calculated by the formula  $H.P. = S^3 D^{\frac{2}{3}} \div c$  in which  $c = 200$  for vessels under 200 ft. long when  $C = 0.65$ , and 210 when  $C = 0.55$ ;  $c = 200$  for vessels 200 to 400 ft. long when  $C = 0.75$ , 220 when  $C = 0.65$ , 240 when  $C = 0.55$ ;  $c = 230$  for vessels over 400 ft. long when  $C = 0.75$ , 250 when  $C = 0.65$ , 260 when  $C = 0.55$ .

The figures in the 8th column are based on 5 H.P. per 100 sq. ft. of wetted surface.

The diameters of screw in the 9th column are from formula  $D = 3.31 \sqrt[5]{I.H.P.}$ , and in the 10th column from formula  $D = 2.71 \sqrt[5]{I.H.P.}$ .

To find the diameter of screw for any other speed than 10 knots, revolutions being 100 per minute, multiply the diameter given in the table by the 5th root of the cube of the given speed  $\div$  10. For any other revolutions per minute than 100, divide by the revolutions and multiply by 100.

To find the approximate horse-power for any other speed than 10 knots, multiply the horse-power given in the table by the cube of the ratio of the given speed to 10, or by the relative figure from table on p. 1373.

F. E. Cardullo, *Mach'y*, April, 1907, gives the following formula as closely approximating the speed of modern types of hulls:  $S = 6.35$

$\sqrt[3]{\frac{I.H.P.}{D^{2/3}}}$ , in which  $S =$  speed in knots,  $D =$  displacement in tons. If

we take  $S = 10$  knots, then  $I.H.P. \div D^{2/3} = 3.906$ . Let  $D = 10,000$ , and  $S = 10$ , then  $H.P. = 1813$ . The table on page 1375 gives for a displacement of 10,400 tons and a coefficient of fineness 0.65, 1966 and 1760 H.P., averaging 1863 H.P.

**Internal Combustion Marine Engines.** — Linton Hope (*Eng'g*, April 8, 1910), in a paper on the application of internal combustion engines to fishing boats and fine-lined commercial vessels, gives a table showing the brake H.P. required to propel such vessels at various speeds. The following table is an abridgment.  $L =$  load water line;  $D =$  displacement in tons.

Block Coefficient.								Speed in Knots.							
0.25		0.3		0.35		0.4		4	5	6	7	8	9	10	
L	D	L	D	L	D	L	D	Brake Horse-power.							
78	105	75	100	72	95	69	90	20	30	43	60	81	110	150	
71	81	69	77	66	73	63	70	17	25	37	51	69	93	.....	
65	62	63	60	60	58	57	55	15	22	32	44	60	82	.....	
59	47	57	45	54	44	52	42	13	19	27	39	53	76	.....	
54	36	52	35	50	34	48	32	11	16	24	34	48	71	.....	
50	28	48	27	46	26	44	25	9	13	20	29	44	.....	.....	
46	22	44	21	42	20	40	19	8	12	17	25	40	.....	.....	
41	17	40	16	38	15	37	14	7	11	15	22	37	.....	.....	
38	13	37	12	35	11 1/2	34	11	6	9	13	19	34	.....	.....	
35	9	34	8 1/2	32	8	31	7 1/2	5	7	11	16	.....	.....	.....	
32	6 1/2	31	6	30	5 1/2	29	5	4	5 1/2	9	14	.....	.....	.....	
30	4 1/2	29	4 1/4	28	3 3/4	27	3 1/2	3	5	7	12	.....	.....	.....	
28	3 1/4	27	3	26	2 3/4	25	2 1/2	2 1/2	4 1/2	6 1/2	11	.....	.....	.....	

## Estimated Displacement, Horse-power, etc., of Steam-vessels of Various Sizes.

Length, feet, L	Breadth, feet, B	Draught, feet, D	Coefficient of Fine- ness, C	Displacement,	Wetted Surface L (1.7 D + BC) sq. ft.	Estimated Horse- power at 10 knots.		Diam. of Screw for 10, knots speed and 100 revs. per minute.	
				$LBD \times C$ 85 tons.		Calc. from Dis- placem't.	Calc. from Wetted Surface.	If Pitch = Diam.	If Pitch = 1.4 Diam.
12	3	1.5	.55	0.85	48	4.3	2.4	4.4	3.6
16	3	1.5	.55	1.13	64	5.2	3.2	4.6	3.8
	4	2	.65	2.38	96	8.9	4.8	5.1	4.2
20	3	1.5	.55	1.41	80	6.0	4.0	4.7	3.9
	4	2	.65	2.97	120	10.3	6.0	5.3	4.3
24	3.5	1.5	.55	1.98	104	7.5	5.2	5	4.1
	4.5	2	.65	4.01	152	12.6	7.6	5.5	4.5
30	4	2	.55	3.77	168	11.5	8.4	5.4	4.4
	5	2.5	.65	6.96	224	18.2	11.2	5.9	4.8
40	4.5	2	.55	5.66	235	15.1	11.8	5.7	4.7
	6	2.5	.65	11.1	326	24.9	16.3	6.3	5.2
50	6	3	.55	14.1	420	27.8	21.0	6.4	5.4
	8	3.5	.65	26	558	43.9	27.9	7.1	5.8
60	8	3.5	.55	26.4	621	42.2	31.1	7.0	5.7
	10	4	.65	44.6	798	62.9	39.9	7.6	6.2
70	10	4	.55	44	861	59.4	43.1	7.5	6.1
	12	4.5	.65	70.2	1082	85.1	54.1	8.1	6.6
80	12	4.5	.55	67.9	1140	79.2	57.0	7.9	6.5
	14	5	.65	104.0	1408	111	70.4	8.5	7.0
90	13	5	.55	91.9	1408	97	70.4	8.3	6.8
	16	6	.65	160	1854	147	92.7	9	7.3
100	13	5	.55	102	1565	104	78.3	8.4	6.9
	15	5.5	.65	153	1910	143	95.5	8.9	7.3
120	17	6	.75	219	2295	202	115	9.6	7.8
	14	5.5	.55	145	2046	131	102	8.8	7.2
140	16	6	.65	214	2472	179	124	9.4	7.6
	18	6.5	.75	301	2946	250	147	10	8.2
160	16	6	.55	211	2660	169	133	9.2	7.4
	18	6.5	.65	306	3185	227	159	9.8	8.0
180	20	7	.75	420	3766	312	188	10.5	8.5
	17	6.5	.55	278	3264	203	163	9.6	7.8
200	19	7	.65	395	3880	269	194	10.1	8.3
	21	7.5	.75	540	4560	368	228	10.8	8.8
220	20	7	.55	396	4122	257	206	10.1	8.2
	22	7.5	.65	552	4869	337	243	10.6	8.7
240	24	8	.75	741	5688	455	284	11.3	9.2
	22	7	.55	484	4800	257	240	10.1	8.2
260	25	8	.65	743	5970	373	299	10.8	8.8
	28	9	.75	1080	7260	526	363	11.6	9.5
280	28	8	.55	880	7250	383	363	10.9	8.9
	32	10	.65	1486	9450	592	473	11.9	9.7
300	36	12	.75	2314	11850	875	593	12.8	10.5
	32	10	.55	1509	10380	548	519	11.7	9.6
320	36	12	.65	2407	13140	806	657	12.6	10.4
	40	14	.75	3600	17140	1175	857	13.6	11.1
350	38	12	.55	2508	14455	769	723	12.5	10.2
	42	14	.65	3822	17885	1111	894	13.5	11.0
380	46	16	.75	5520	21595	1562	1080	14.4	11.8
	44	14	.55	3872	19200	1028	960	13.3	10.8
400	48	16	.65	5705	23360	1451	1168	14.2	11.6
	52	18	.75	8023	27840	2006	1392	15.2	12.4
450	50	16	.55	5657	24515	1221	1226	13.7	11.2
	54	18	.65	8123	29565	1616	1478	14.5	11.9
500	58	20	.75	11157	34875	2171	1744	15.4	12.6
	52	18	.55	7354	29600	1454	1480	14.2	11.6
550	56	20	.65	10400	35200	1966	1760	15.1	12.4
	60	22	.75	14143	41200	2543	2060	15.9	13.0
600	56	20	.55	9680	36245	1747	1812	14.7	12.0
	60	22	.65	13483	42735	2266	2137	15.5	12.7
650	64	24	.75	18103	49665	2998	2483	16.4	13.4
	60	22	.55	12446	42900	2065	2145	15.2	12.5
700	64	24	.65	17115	50220	2656	2511	15.4	13.1
	68	26	.75	22731	58020	3489	2901	16.9	13.8



**DATA OF SHIPS OF VARIOUS TYPES.**  
(From Peabody on Propellers.)

Type.	Name.	Date.	Length, Ft.	Breadth, Ft.	Draft, Ft. on Trial.	Displacement Tons, on Trial.	Block Coefficient Trial.	Wetted Surface, Sq. Ft.	Speed, Knots	Horse Power Indicated	I.H.P. per Ton Displacement.	Admiralty Coefficient.	Rev. per Min. on Trial.	Speed ÷ $\sqrt{\text{Length}}$
High-Speed	{ Lusitania.....	1908	760	87-6"	32-9"	37,080	0.596	85,500	25.62	76,000	2.05	245	94	0.93
Passenger	{ La Provence....	1906	597	64-7"	26-8"	19,160	0.649	54,500	22.05	30,000	1.66	255	.....	0.90
Passenger and Freight	{ Otaki.....	1909	465	60	20	11,716	0.735	35,700	15.02	10,150	0.58	255	.....	0.70
	{ Minnesota.....	1903	608	73	33	33,000	0.790	75,200	14.00	10,000	0.303	282	80	0.57
	{ Nebraska.....	1902	358	46	23	8,380	0.760	28,990	10.30	1,635	0.195	262	.....	0.55
Freight	{ Cargo Steamer.	1900	420	53	24	11,940	0.788	36,100	10.84	2,494	0.209	267	.....	0.53
	{ Noma.....	1903	226	28	13	1,035	0.434	8,000	19.06	4,200	4.06	163	205	1.27
Yachts	{ Vanadis.....	1908	233	32	13	1,467	0.544	9,540	13.00	1,050	0.716	270	152	0.85
Side-Wheelers	{ Commonwealth.	1908	438	55	13	5,430	0.608	25,200	20.05	12,000	2.21	209	30	0.96
	{ Uncatena.....	1903	179	31	6	608	0.603	5,535	13.00	982	1.63	160	29	0.97
Battleships	{ North Carolina.	1908	502	76	24	14,680	0.652	42,000	19.01	19,889	1.36	207	125	0.91
	{ Delaware.....	1909	510	85	27	20,098	0.603	53,000	21.56	28,578	1.43	259	128	0.95
Scout	{ Birmingham....	1908	420	47	17	3,722	0.410	19,900	24.33	15,476	4.16	223	191	1.18
Destroyer	{ Flusser.....	1910	289	27	8	686	0.405	7,150	30.40	11,541	16.8	190	800	1.76
Motor Boats	{ Dixie II.....	1908	39	4-8"	0-11"	2	0.420	.....	31.05	220*	109.5	217	900	4.95
	{ Chum.....	1906	25	4	0-10"	0.7	0.304	.....	12.70	10*	13.8	165	.....	2.54

\* Shaft horse-power.

**Relation of Horse-Power to Speed.**—If  $S_1$  and  $S_2$  are two successive speeds and  $P_1P_2$  the corresponding horse-powers, then to find the value of the exponent  $x$  in the equation  $H.P. \propto S^x$ , we have  $x = (\log P_2 - \log P_1) \div (\log S_2 - \log S_1)$ . Applying this formula to the horse-powers and speeds of the "Lusitania," we find that between 15.77 and 18 knots  $x = 3.21$ ; between 18 and 21 knots  $x = 3.09$ ; between 21 and 23 knots  $x = 4.12$ ; between 23 and 25.4 knots  $x = 3.63$ .



$$D = \text{diameter of propeller} = K \sqrt{\frac{\text{I.H.P.}}{\left(\frac{P \times R}{100}\right)^3}}, K \text{ being a coefficient given}$$

in the table below. If  $K = 20$ ,  $D = 20,000 \sqrt{\text{I.H.P.} \div (P \times R)^3}$ .

Total developed area of blades =  $C \sqrt{\text{I.H.P.} \div R}$ , in which  $C$  is a coefficient to be taken from the table.

Another formula for pitch, given in Seaton's Marine Engineering, is

$$P = \frac{C}{R} \sqrt[3]{\frac{\text{I.H.P.}}{D^2}}, \text{ in which } C = 737 \text{ for ordinary vessels, and } 660 \text{ for slow-speed cargo vessels with full lines.}$$

Thickness of blade at root =  $\sqrt{\frac{d^3}{nb}} \times k$ , in which  $d$  = diameter of tail shaft in inches,  $n$  = number of blades,  $b$  = breadth of blade in inches where it joins the boss, measured parallel to the shaft axis;  $k = 4$  for cast iron, 1.5 for cast steel, 2 for gun-metal, 1.5 for high-class bronze.

Thickness of blade at tip: Cast iron  $0.04 D + 0.4$  in.; cast steel  $0.03 D + 0.4$  in.; gun-metal  $0.03 D + 0.2$  in.; high-class bronze  $0.02 D + 0.3$  in., where  $D$  = diameter of propeller in feet.

**Propeller Coefficients.**

Description of Vessel.	Approx. Speed, Knots.	No. of Screws.	No. of Blades per Screw	Values of K.	Values of C.	Usual Material of Blades.
Bluff cargo boats.....	8-10	One	4	17 -17.5	19 -17.5	Cast iron
Cargo, moderate lines....	10-13	"	4	18 -19	17 -15.5	" "
Pass. and mail, fine lines..	13-17	"	4	19.5-20.5	15 -13	C.I. or S.
" " " " "	13-17	Twin	4	20.5-21.5	14.5-12.5	" "
" " " very fine... ..	17-22	One	4	21 -22	12.5-11	G.M. or B.
" " " " "	17-22	Twin	3	22 -23	10.5- 9	" "
Naval vessels, " " ..	16-22	"	4	21 -22.5	11.5-10.5	" "
" " " " "	16-22	"	3	22 -23.5	8.5-7	" "
Torpedo-boats, " " ..	20-26	One	3	25	7-6	B. or F.S.

C. I., cast iron; G. M., gun-metal; B., bronze; S., steel; F.S., forged steel.

From the formulæ  $D = 20,000 \sqrt{\frac{\text{I.H.P.}}{(P \times R)^3}}$  and  $P = \sqrt{\frac{737 \text{I.H.P.}}{R D^2}}$ , if

$P = D$  and  $R = 100$ , we obtain  $D = \sqrt[5]{400 \times \text{I.H.P.}} = 3.31 \sqrt[5]{\text{I.H.P.}}$

If  $P = 1.4 D$  and  $R = 100$ , then  $D = \sqrt[5]{145.8 \times \text{I.H.P.}} = 2.71 \sqrt[5]{\text{I.H.P.}}$

From these two formulæ the figures for diameter of screw in the table on page 1375 have been calculated. They may be used as rough approximations to the correct diameter of screw for any given horse-power, for a speed of 10 knots and 100 revolutions per minute.

For any other number of revolutions per minute multiply the figures in the table by 100 and divide by the given number of revolutions. For any other speed than 10 knots, since the I.H.P. varies approximately as the cube of the speed, and the diameter of the screw as the 5th root of the I.H.P., multiply the diameter given for 10 knots by the 5th root of the cube of one-tenth of the given speed. Or, multiply by the following factors:

For speed of knots:										
$\frac{4}{\sqrt[5]{(S \div 10)^3}}$	$\frac{5}{\sqrt[5]{(S \div 10)^3}}$	$\frac{6}{\sqrt[5]{(S \div 10)^3}}$	$\frac{7}{\sqrt[5]{(S \div 10)^3}}$	$\frac{8}{\sqrt[5]{(S \div 10)^3}}$	$\frac{9}{\sqrt[5]{(S \div 10)^3}}$	$\frac{11}{\sqrt[5]{(S \div 10)^3}}$	$\frac{12}{\sqrt[5]{(S \div 10)^3}}$	$\frac{13}{\sqrt[5]{(S \div 10)^3}}$	$\frac{14}{\sqrt[5]{(S \div 10)^3}}$	$\frac{16}{\sqrt[5]{(S \div 10)^3}}$
0.577	0.660	0.736	0.807	0.875	0.939	1.059	1.116	1.170	1.224	1.327
Speed:										
$\frac{17}{\sqrt[5]{(S \div 10)^3}}$	$\frac{18}{\sqrt[5]{(S \div 10)^3}}$	$\frac{19}{\sqrt[5]{(S \div 10)^3}}$	$\frac{20}{\sqrt[5]{(S \div 10)^3}}$	$\frac{21}{\sqrt[5]{(S \div 10)^3}}$	$\frac{22}{\sqrt[5]{(S \div 10)^3}}$	$\frac{23}{\sqrt[5]{(S \div 10)^3}}$	$\frac{24}{\sqrt[5]{(S \div 10)^3}}$	$\frac{25}{\sqrt[5]{(S \div 10)^3}}$	$\frac{26}{\sqrt[5]{(S \div 10)^3}}$	$\frac{28}{\sqrt[5]{(S \div 10)^3}}$
1.375	1.423	1.470	1.515	1.561	1.605	1.648	1.691	1.733	1.774	1.855

For more accurate determinations of diameter and pitch of screw, the formulæ and coefficients given by Seaton, quoted above, should be used.



**Efficiency of the Propeller.** — According to Rankine, if the slip of the water be  $s$ , its weight  $W$ , the resistance  $R$ , and the speed of the ship  $v$ ,  
 $R = Ws \div g$ ;  $Rv = Wsv \div g$ .

This impelling action must, to secure maximum efficiency of propeller, be effected by an instrument which takes hold of the fluid without shock or disturbance of the surrounding mass, and, by a steady acceleration, gives it the required final velocity of discharge. The velocity of the propeller overcoming the resistance  $R$  would then be

$$[v + (v + s)] \div 2 = v + s/2;$$

and the work performed would be

$$R(v + s/2) = Wvs \div g + Ws^2 \div 2g,$$

the first of the last two terms being useful, the second the minimum lost work; the latter being the wasted energy of the water thrown backward. The efficiency is  $E = v \div (v + s/2)$ ; and this is the limit attainable with a perfect propelling instrument, which limit is approached the more nearly as the conditions above prescribed are the more nearly fulfilled. The efficiency of the propelling instrument is probably rarely much above 0.60, and never above 0.80.

In designing the screw-propeller, as was shown by Dr. Froude, the best angle for the surface is that of  $45^\circ$  with the plane of the disk; but as all parts of the blade cannot be given the same angle, it should, where practicable, be so proportioned that the "pitch-angle at the center of effort" should be made  $45^\circ$ . The maximum possible efficiency is then, according to Froude, 77%. In order that the water should be taken on without shock and discharged with maximum backward velocity, the screw must have an axially increasing pitch.

The true screw is the usual form of propeller in all steamers, both merchant and naval. (Thurston, Manual of the Steam-engine, part ii, p. 176.)

The combined efficiency of screw, shaft, engine, etc., is generally taken at 50%. In some cases it may reach 60% or 65%. Rankine takes the effective H.P. to equal the I.H.P.  $\div 1.63$ .

**Results of Researches** on the efficiency of screw-propellers are summarized by S. W. Barnaby, in a paper read before section G of the Engineering Congress, Chicago, 1893. He states that the following general principles have been established:

(a) There is a definite amount of real slip at which, and at which only, maximum efficiency can be obtained with a screw of any given type, and this amount varies with the pitch-ratio. The slip-ratio proper to a given ratio of pitch to diameter has been discovered and tabulated for a screw of a standard type, as below:

**Pitch-ratio and Slip for Screws of Standard Form.**

Pitch-ratio.	Real Slip of Screw.	Pitch-ratio.	Real Slip of Screw.	Pitch-ratio.	Real Slip of Screw.
0.8	15.55	1.4	19.5	2.0	22.9
0.9	16.22	1.5	20.1	2.1	23.5
1.0	16.88	1.6	20.7	2.2	24.0
1.1	17.55	1.7	21.3	2.3	24.5
1.2	18.2	1.8	21.8	2.4	25.0
1.3	18.8	1.9	22.4	2.5	25.4

(b) Screws of large pitch-ratio, besides being less efficient in themselves, add to the resistance of the hull by an amount bearing some proportion to their distance from it, and to the amount of rotation left in the race.

(c) The best pitch-ratio lies probably between 1.1 and 1.5.

(d) The fuller the lines of the vessel, the less the pitch-ratio should be.

(e) Coarse-pitched screws should be placed further from the stern than fine-pitched ones.

(f) Apparent negative slip is a natural result of abnormal proportions of propellers.

(g) Three blades are to be preferred for high-speed vessels, but when the diameter is unduly restricted, four or even more may be advantageously employed.

(h) An efficient form of blade is an ellipse having a minor axis equal to four-tenths the major axis.

(i) The pitch of wide-bladed screws should increase from forward to aft, but a uniform pitch gives satisfactory results when the blades are

narrow, and the amount of the pitch variation should be a function of the width of the blade.

(j) A considerable inclination of screw-shaft produces vibration, and with right-handed twin-screws turning outwards, if the shafts are inclined at all, it should be upwards and outwards from the propellers.

For results of experiments with screw-propellers, see F. C. Marshall, *Proc. Inst. M. E.*, 1881; R. E. Froude, *Trans. Inst. Nav. Archs.*, 1886; G. A. Calvert, *Trans. Inst. Nav. Archs.*, 1887; S. W. Barnaby, *Proc. Inst. C. E.*, 1890, vol. cii, and D. W. Taylor's "Resistance of Ships and Screw Propulsion." Also Mr. Taylor's paper in *Proc. Soc. Nav. Arch. & Marine Engrs.*, 1904. Mr. Taylor found the highest efficiencies, exceeding 70%, in propellers with pitch ratios from 1.0 to 1.5 ratio of width of blade to diameter of  $\frac{1}{8}$  to  $\frac{1}{5}$ , and ratio of developed area of blade to disk area of 0.201 to 0.322.

One of the most important results deduced from experiments on model screws is that they appear to have practically equal efficiencies throughout a wide range both in pitch-ratio and in surface-ratio; so that great latitude is left to the designer in regard to the form of the propeller. Although these experiments are not a direct guide to the selection of the most efficient propeller for a particular ship, they supply the means of analyzing the performances of screws fitted to vessels, and of thus indirectly determining what are likely to be the best dimensions of screw for a vessel of a class whose results are known. (*Proc. Inst. M. E.*, July, 1891.)

Mr. Barnaby in *Proc. Inst. C. E.*, 1890, gives a table to be used in calculations for determining the best dimensions of screws for any given speed and H.P. from which the following table is abridged. It is deduced from Froude's experiments at Torquay. (*Trans. Inst. Nav. Archs.*, 1886.)

$C_A$  = disk area in sq. ft.  $\times V^3/H.P.$   $C_R$  = revs. per min.  $\times D/V$ .  $V$  = speed in knots,  $D$  = diam. of screw in ft. H.P. = effective H.P. on the screw shaft. Disk area =  $0.7854 D^2 = C_A \times I.H.P./V^3$ . Revs. per min. =  $C_R \times V/D$ . The constants  $C_A$  and  $C_R$  assume a standard value of the speed of the wake, equal to 10% of the speed of the ship. In a very full ship it may amount to 30%, therefore  $V$  should be reduced when using the constants by amounts varying from 20% to 0 as the form varies from "very full" to "fairly fine."

Effy. of Screw, %.	63		67		68		69		68		66		63	
	$C_A$	$C_R$	$C_A$	$C_R$	$C_A$	$C_R$	$C_A$	$C_R$	$C_A$	$C_R$	$C_A$	$C_R$	$C_A$	$C_R$
Pitch ratio.														
0.80	468	122	304	128	215	134	157	142	115	150	86	160	65	171
1.00	546	99	355	104	251	109	184	115	135	123	100	131	76	140
1.20	625	83	405	87	288	92	210	97	154	104	115	111	87	119
1.40	704	72	456	76	325	80	236	85	173	90	129	97	98	104
1.60	780	63	507	67	360	71	263	75	193	80	144	87	109	93
1.80	.....	.....	558	60	396	64	290	68	212	73	159	78	120	84
2.00	.....	.....	609	55	432	58	315	62	231	67	173	72	131	77
2.20	.....	.....	660	50	469	54	342	57	250	62	187	67	142	72
2.40	.....	.....	710	47	505	50	369	53	270	57	202	62	153	67

**Comparison of Marine Engines for the Years 1872, 1881, 1891, 1901.**  
(Jas. McKechnie, *Proc. Inst. M. E.* 1901.)

Boilers, Engines and Coal.	Average Results.			
	1872.	1881.	1891.	1901.
Boiler press., lbs. per sq. in.....	52.4	77.4	158.5	197
Heating surface, per sq. ft. grate.....	.....	30.4	31.0	38 & 43*
Heat'g surf., per I.H.P., sq. ft.....	4.41	3.917	3.275	3.0
Coal, per sq. ft. of grate, lbs. per hr.....	.....	13.8	15.0	18 & 28*
Revolutions per minute.....	55.67	59.76	63.75	87
Piston speed, ft. per min.....	376	467	529	654
Coal per I.H.P. per hr., lbs.....	2.11	1.83	1.52	1.48
Av. consumption, long voyage.....	.....	2.0	1.75	1.55

\* Natural and forced draft respectively.

Summary of Results. (1891 to 1901).—Steam pressures have been increased in the merchant marine from 158 lbs. to 197 lbs. per sq. in.

the maximum attained being 267 lbs. per sq. in., and 300 lbs. in the naval service. The piston speed of mercantile machinery has gone up from 529 to 654 ft. per minute, the maximum in merchant practice being about 900 ft., and in naval practice 960 ft. for large engines, and 1300 ft. in torpedo-boat destroyers. Boilers also yield a greater power for a given surface, and thus the average power per ton of machinery has gone up from an average of 6 to about 7 I.H.P., while ten years ago the highest sustained ocean speed was 20.7 knots, it is now 23.38 knots; the highest speed for large warships was 22 knots and is now 23 knots on a trial of double the duration; the maximum speed attained by any craft was 25 knots, as compared with 36.581 knots now, while the number of ships of over 20 knots was 8 in 1891, and is 58 now (1901).

**Turbines and Boilers of the "Lusitania."** (Thomas Bell, *Proc. Inst. Nav. Archts.*, 1908.)—Some of the principal dimensions of the turbines and boilers of the "Lusitania" are as follows:

Turbines.	Diameter of Rotor, Ins.	Length of Blades, Ins.	
		In First Expansion.	In Last Expansion.
H.P. ....	96	2 3/4	12 3/8
L.P. ....	140	8 1/4	22
Astern. ....	104	2 1/4	8

Total cooling surface, main condensers, 82,800 sq. ft.; area of exhaust inlet, 158 sq. ft.; bore of circulating discharge pipes, 32 ins.

**BOILERS.**—Working pressure, 195 lbs. per sq. in.; 23 double-ended boilers, 17 ft. 6 in. mean diameter by 22 ft. long; 2 single-ended boilers, 17 ft. 6 in. mean diameter by 11 ft. 4 in. long; total number of furnaces, 192; total grate surface, 4048 sq. ft.; total heating surface, 158,352 sq. ft.; total length of boiler-rooms, 336 ft.; total length of main and auxiliary engine rooms, 149 ft. 8 in.

The following are the weights of the various revolving parts, and the size of bearings and the pressure: Weight of one H.P. turbine rotor complete, 86 tons; one L.P. rotor, 120 tons; one astern rotor, 62 tons.

	Main Bearing Journals.		Pressure per Sq. In. of Bearing Surface.	At. 190 Revs. Surface Speed of Journal.
	Diameter.	Effective Length.		
H.P. rotor. ....	27 1/8 in.	44 3/4 in.	80 lbs.	1350 ft. per min.
L.P. rotor. ....	33 1/8 in.	56 1/2 in.	72 lbs.	1650 ft. per min.
Astern rotor. ....	24 1/8 in.	34 3/4 in.	83 lbs.	1200 ft. per min.

**Performance of the "Lusitania."** (Thos. Bell, *Proc. Inst. Nav. Archts.*, 1908; *Power*, May 12, 1908.)—The following records were obtained in the official trials:

Speed in knots. ....	15.77	18	21	23	25.4
Shaft horse-power. ....	13,400	20,500	33,000	48,000	68,850
Steam cons. per shaft, H.P. hr.					
of turbines, lbs. ....	21.23	17.24	14.91	13.92	12.77
of auxiliaries, lbs. ....	5.3	3.72	2.6	2.01	1.69
total lbs. ....	26.53	20.96	17.51	15.93	14.46
Temp. of feed-water, ° F. ....	200	200	199	179	165
Coal cons. lbs. per shaft					
H.P. hr. ....	2.52	2.01	1.68	1.56	1.43
Estimated steam and coal consumption under service conditions, at same speeds:					
Steam cons. of auxiliaries, per shaft H.P. hr., lbs. ....	6.97	4.92	3.41	2.65	2.17
Steam cons. of total per shaft H.P. hr., lbs. ....	28.20	22.16	18.32	16.57	14.94
Coal cons., lbs. per shaft H.P. hr., lbs. ....	2.76	2.17	1.8	1.62	1.46
Est. coal cons., on a voyage of 3100 nautical miles, gross tons. ....	3,270	3,440	3,930	4,700	5,490

The following figures are taken from the records of a voyage from



## Dimensions and Performances of Notable Atlantic Steamers (Eng'g, Aug. 2, 1907).

Name.	Date.	Length, ft.*	Breadth, ft.	Depth, ft.	Draft, ft.	Displacement,†	Gross Tonnage.	Steam Pressure.	Indicated H.P.	Speed on Trial, Knots.	Cylinders, diam., ins.	Stroke, ins.	Heating Surface, sq. ft.	Grate Surface, sq. ft.
Great Eastern.....	1858	680 80	83	57.5	27	24.4	30	7,650	14.5	Screw, 4, 84; paddle, 4, 74	60	.....	.....	
Britannic.....	1874	455 45	36	23.5	8.5	5	70	5,500	16	2, 48; 2, 83	66	.....	.....	
Arizona.....	1879	450 45	37.5	22	9.9	7.4	90	6,300	17	1, 62; 2, 90	78	27,483	1014	
Arizona.....	1881	515 52	40.5	23.2	9.9	7.4	90	10,300	17	1, 72; 2, 100	72	.....	.....	
Alaska.....	1881	500 50	39.7	22	8.1	6.9	100	10,500	18	1, 68; 2, 100	72	29,286	1398	
City of Rome.....	1881	543 52	38.8	22	11.2	8.1	90	11,900	18.2	3, 46; 3, 86	72	38,047	1428	
Oregon.....	1883	500 54	40	23	10.5	7.4	110	13,300	18.3	1, 70; 2, 104	72	38,817	1606	
Umbria.....	1884	500 57	40	22.5	10.5	7.7	110	14,320	20.18	1, 71; 2, 105	60	50,265	1293	
Paris.....	1888	528 63	41.1	23	13	10.5	150	20,000	21.8	2, 45; 2, 71; 2, 113	60	40,072	1154	
Teutonic.....	1890	565 57.5	42.2	22	12	9.7	180	19,500	21	2, 43; 2, 68; 2, 110	60	82,000	2630	
Campania.....	1893	600 65	41.5	23	18	12.5	165	30,000	22.01	4, 37; 2, 79; 4, 98	69	84,285	2618	
Kais. Wilhelm d. Grosse	1897	625 66	43	28	20.9	14.3	178	30,000	22.5	2, 52; 2, 89; 4, 96	72	74,686	1962	
Oceanic.....	1899	685 68.5	49.0	32.5	28.5	17.3	192	27,000	20.72	2, 47 1/2; 2, 79; 4, 93	73	85,468	2188	
Deutschland.....	1901	663 67	44	29	23.6	16.5	220	36,000	23.5	4, 36.6; 2, 73.6; 2, 103.9; 4, 106.3	71	107,643	3121	
Kaiser Wilhelm II.....	1903	678 72	52.5	29	26	20	225	38,000	23.5	4, 37.4; 4, 49.2; 4, 74.8; 4, 112.2	.....	158,350	4048	
Lusitania.....	1907	760 88	60.4	33.5	38	32.5	195	68,000	25	Turbines	.....	.....	.....	

\* Between perpendiculars. † Thousands of tons.

**Relative Economy of Turbines and Reciprocating Engine.** (C. A. Parsons, *Trans. Inst. Nav. Archts.*, 1910.) — The "Vespasian," a cargo vessel 275 ft. long, 38 ft. 9 in. breadth, 19 ft. 8 in. mean loaded draught, 4350 tons displacement, was at first fitted with a triple-expansion engine, cylinders 22 1/4, 35 and 59 ins., 42-in. stroke; and afterwards with two Parsons turbines, high and low pressure, each connected by a flexible coupling to a 20-tooth pinion, the two pinions gearing into a wheel 8 ft. 3 in. pitch diam., with 398 double helical teeth, 20° angle, 24 in. face, the gear ratio being 19.9 to 1. The boilers, propeller, shafting and thrust block remained the same as with the reciprocating engine. Tests were made before and after the installation of the turbines with the following results: At a speed of 8.87 knots the reciprocating engine used 11,750 lbs. of water per hour, as against 10,750 lbs. taken by the turbines — a saving of 8.5%; at 9.55 knots the figures were 14,500 and 12,600, respectively — a saving of 13.0%; at 10.2 knots, 17,500 and 14,750 lbs., respectively — a saving of 16.0%.

Queenstown to Sandy Hook, 2781 nautical miles, Nov. 3-8, 1908, 4 days, 18 hrs., 40 m.: Averages: Steam pressure at boilers, 168 lbs.; temperature hot-well, 74.5°; feed-water, 197°; vacuum, 28.1 in.; speed, 24.25 knots; speed, best day, 24.8 knots; revolutions, 181.1; slip, 15.9%. Total coal, 4976 tons. Steam consumption: main turbines, 851,500 lbs., = 13.1 lbs. per shaft H.P. hr. (on a basis of 65,000 shaft H.P.); auxiliary machinery, 114,000 lbs., = 1.75 per H.P. hr.; evaporating plant and heating, 32,500 lbs., = 0.5 lb. per H.P. hr. Total, 998,000 lbs., = 15.35 lbs. per shaft H.P. hour. Average coal burned, 43½ tons per hour. Water evaporated per lb., coal 10.2 lbs. from feed at 196°, = 10.9 lbs. from and at 212°. Coal for all purposes per shaft H.P. hour, 1.5 lbs. Coal per sq. ft. of grate per hour, 24.1 lbs. The coal was half Yorkshire, half South Wales.

In September, 1909, the "Lusitania" made the westward passage, 2784 miles from Daunt's Rock near Queenstown to Ambrose Channel Lightship, off Sandy Hook, in 4 days 11 h. 42 m., averaging 25.85 knots for the entire passage. Four successive days runs, from noon to noon, were 650, 652, 651 and 674 miles.

**Reciprocating Engines with a Low-Pressure Turbine.** — The "Laurentic," built for the Canadian trade of the White Star Line, 14,000 tons gross register, is a triple-screw steamer, with the two outer screws driven by four-cylinder triple-expansion engines, and the central screw by a Parsons turbine. The steam, of 200 lbs. boiler pressure, first passes to the reciprocating engines, where it expands to from 14 to 17 lbs. absolute, and then passes to the turbine. For manœuvering the ship into and out of port the turbine is not used, and the steam passes directly from the engines to the condensers. During the trial trip the combined engine-turbine outfit developed 12,000 H.P., with a speed of 17½ knots, and showed a coal consumption of 1.1 lbs. and a water consumption of 11 lbs. per indicated horse-power hour. (*Power*, May 18, 1909.)

The "Kronprinzessin Cecilie" of the North German Lloyd Co., is probably the last high-speed transatlantic steamer of very great power that will be built with reciprocating engines. Its dimensions are: length, 706 ft.; beam, 72 ft.; depth, 44 ft. 2 in.; displacement, 26,000 tons. Four 12,000 H.P. engines, two on each shaft, in tandem. Cylinders, 37¾, 49¼, 74⅞ and 112¼ ins., by 6 ft. stroke. Steam, 230 lbs., delivered from 19 cylindrical boilers, through four 17-in. steampipes. Coal used in 24 hours, 764 tons, in 124 furnaces; 1.4 lbs. per H.P. hour, including auxiliaries. Speed on trial trip on a 60-mile course, 24.02 knots. (*Sci. Am.*, Aug. 24, 1907.)

## THE PADDLE-WHEEL.

**Paddle-wheels with Radial Floats.** (Seaton's Marine Engineering.) — The effective diameter of a radial wheel is usually taken from the centers of opposite floats; but it is difficult to say what is absolutely that diameter, as much depends on the form of float, the amount of dip, and the waves set in motion by the wheel. The slip of a radial wheel is from 15 to 30 per cent, depending on the size of float.

$$\text{Area of one float} = C \times \text{I.H.P.} + D.$$

$D$  is the effective diameter in feet, and  $C$  is a multiplier, varying from 0.25 in tugs to 0.175 in fast-running light steamers.

The breadth of the float is usually about ¼ its length, and its thickness about ⅓ its breadth. The number of floats varies directly with the diameter, and there should be one float for every foot of diameter.

(For a discussion of the action of the radial wheel, see Thurston, *Manual of the Steam-engine*, part ii, p. 182.)

**Feathering Paddle-wheels.** (Seaton.) — The diameter of a feathering-wheel is found as follows: The amount of slip varies from 12 to 20 per cent, although when the floats are small or the resistance great it is as high as 25 per cent; a well-designed wheel on a well-formed ship should not exceed 15 per cent under ordinary circumstances.

If  $K$  is the speed of the ship in knots,  $S$  the percentage of slip, and  $R$  the revolutions per minute,

$$\text{Diameter of wheel at centers} = K(100 + S) \div (3.14 \times R).$$

The diameter, however, must be such as will suit the structure of the ship, so that a modification may be necessary on this account, and the revolutions altered to suit it. The diameter will also depend on the amount of "dip" or immersion of float,

When a ship is working always in smooth water the immersion of the top edge should not exceed  $\frac{1}{8}$  the breadth of the float; and for general service at sea an immersion of  $\frac{1}{2}$  the breadth of the float is sufficient. If the ship is intended to carry cargo, the immersion when light need not be more than 2 or 3 inches, and should not be more than the breadth of float when at the deepest draught; indeed, the efficiency of the wheel falls off rapidly with the immersion of the wheel.

Area of one float =  $C \times \text{I.H.P.} \div D$ .

$C$  is a multiplier, varying from 0.3 to 0.35;  $D$  is the diameter of the wheel to the float centers, in feet.

The number of floats =  $\frac{1}{2}(D + 2)$ .

The breadth of the float =  $0.35 \times$  the length.

The thickness of floats =  $\frac{1}{12}$  the breadth.

Diameter of gudgeons = thickness of float.

Seaton and Rounthwaite's Pocket-book gives:

Number of floats =  $60 \div \sqrt{R}$ ,

where  $R$  is number of revolutions per minute.

Area of one float (in square feet) =  $\frac{\text{I.H.P.} \times 33,000 \times K}{N \times (D \times R)^3}$ ,

where  $N$  = number of floats in one wheel.

For vessels plying always in smooth water  $K = 1200$ . For sea-going steamers  $K = 1400$ . For tugs and such craft as require to stop and start frequently in a tide-way  $K = 1600$ .

It will be quite accurate enough if the last four figures of the cube  $(D \times R)^3$  be taken as ciphers.

For illustrated description of the feathering paddle-wheel see Seaton's Marine Engineering, or Seaton and Rounthwaite's Pocket-book. The diameter of a feathering-wheel is about one-half that of a radial wheel for equal efficiency. (Thurston.)

**Efficiency of Paddle-wheels.** — Computations by Prof. Thurston of the efficiency of propulsion by paddle-wheels give for light river steamers with ratio of velocity of the vessel,  $v$ , to velocity of the paddle-float at center of pressure,  $V$ , or  $v/V$ , =  $\frac{3}{4}$ , with a dip =  $\frac{3}{20}$  radius of the wheel and a slip of 25 per cent, an efficiency of 0.714; and for ocean steamers with the same slip and ratio of  $v/V$ , and a dip =  $\frac{1}{3}$  radius, an efficiency of 0.685.

### JET-PROPULSION.

Numerous experiments have been made in driving a vessel by the reaction of a jet of water pumped through an orifice in the stern, but they have all resulted in commercial failure. Two-jet propulsion steamers, the "Waterwitch," 1100 tons, and the "Squirt," a small torpedo-boat, were built by the British Government. The former was tried in 1867, and gave an efficiency of apparatus of only 18 per cent. The latter gave a speed of 12 knots, as against 17 knots attained by a sister-ship having a screw and equal steam-power. The mathematical theory of the efficiency of the jet was discussed by Rankine in *The Engineer*, Jan. 11, 1867, and he showed that the greater the quantity of water operated on by a jet-propeller, the greater is the efficiency. In defiance both of the theory and of the results of earlier experiments, and also of the opinions of many naval engineers, more than \$200,000 were spent in 1888-90 in New York upon two experimental boats, the "Prima Vista" and the "Evolution," in which the jet was made of very small size, in the latter case only  $\frac{5}{8}$ -inch diameter, and with a pressure of 2500 lbs. per square inch. As had been predicted, the vessel was a total failure. (See article by the author in *Mechanics*, March, 1891.)

The theory of the jet-propeller is similar to that of the screw-propeller. If  $A$  = the area of the jet in square feet,  $V$  its velocity with reference to the orifice, in feet per second,  $v$  = the velocity of the ship in reference to the earth, then the thrust of the jet (see Screw-propeller, *ante*) is  $2AV(V - v)$ . The work done on the vessel is  $2AV(V - v)v$ , and the work wasted on the rearward projection of the jet is  $\frac{1}{2} \times 2AV(V - v)^2$ .

The efficiency is  $\frac{2AV(V - v)v}{2AV(V - v)v + AV(V - v)^2} = \frac{2v}{V + v}$ . This expression equals unity when  $V = v$ , that is, when the velocity of the jet with reference to the earth, or  $V - v$ , = 0; but then the thrust of the propeller is also 0. The greater the value of  $V$  as compared with  $v$ , the less the



efficiency. For  $V = 20 v$ , as was proposed in the "Evolution," the efficiency of the jet would be less than 10 per cent, and this would be further reduced by the friction of the pumping mechanism and of the water in pipes.

The whole theory of propulsion may be summed up in Rankine's words: "That propeller is the best, other things being equal, which drives astern the largest body of water at the lowest velocity."

It is practically impossible to devise any system of hydraulic or jet propulsion which can compare favorably, under these conditions, with the screw or the paddle-wheel.

**Reaction of a Jet.** — If a jet of water issues horizontally from a vessel, the reaction on the side of the vessel opposite the orifice is equal to the weight of a column of water the section of which is the area of the orifice, and the height is twice the head.

The propelling force in jet-propulsion is the reaction of the stream issuing from the orifice, and it is the same whether the jet is discharged under water, in the open air, or against a solid wall. For proof, see account of trials by C. J. Everett, Jr., given by Prof. J. Burkitt Webb, *Trans. A. S. M. E.*, xii, 904.

## CONSTRUCTION OF BUILDINGS.\*

### FOUNDATIONS.

**Bearing Power of Soils.** — Ira O. Baker, "Treatise on Masonry Construction."

Kind of Material.	Bearing Power in Tons per Square Foot.	
	Minimum.	Maximum.
Rock — the hardest — in thick layers, in native bed.	200	.....
Rock equal to best ashlar masonry.....	25	30
Rock equal to best brick masonry.....	15	20
Rock equal to poor brick masonry.....	5	10
Clay on thick beds, always dry.....	4	6
Clay on thick beds, moderately dry.....	2	4
Clay, soft.....	1	2
Gravel and coarse sand, well cemented.....	8	10
Sand, compact, and well cemented.....	4	6
Sand, clean, dry.....	2	4
Quicksand, alluvial soils, etc.....	0.5	1

The building code of Greater New York specifies the following as the maximum permissible loads for different soils:

- "Soft clay, one ton per square foot;
- "Ordinary clay and sand together, in layers, wet and springy, two tons per square foot;
- "Loam, clay or fine sand, firm and dry, three tons per square foot;
- "Very firm coarse sand, stiff gravel or hard clay, four tons per square foot, or as otherwise determined by the Commissioner of Buildings having jurisdiction."

\* The limitations of space forbid any extended treatment of this subject. Much valuable information upon it will be found in Trautwine's "Civil Engineers' Pocket-book," and in Kidder's "Architects' and Builders' Pocket-book." The latter in its preface mentions the following works of reference: "Notes on Building Construction," 3 vols., Rivingtons, publishers, London; "Building Superintendence," by T. M. Clark (J. R. Osgood & Co., Boston); "The American House Carpenter," and "The Theory of Transverse Strains," both by R. G. Hatfield; "Graphical Analysis of Roof-trusses," by Prof. C. E. Greene; "The Fire Protection of Mills," by C. J. H. Woodbury; "House Drainage and Water Service," by James C. Bayles; "The Builder's Guide and Estimator's Price-book," and "Plastering Mortars and Cements," by Fred. T. Hodgson; "Foundations and Concrete Works," and "Art of Building," by E. Dobson, Weale's Series, London.

**Bearing Power of Piles.** — *Engineering News Formula:* Safe load in tons =  $2 Wh \div (S + 1)$ .  $W$  = weight of hammer in tons,  $h$  = height of fall of hammer in feet,  $S$  = penetration under last blow, or the average under last five blows, in inches.

**Safe Strength of Brick Piers,** exceeding six diameters in height. (Kidder.)

Piers laid with rich lime mortar, lbs. per sq. in.,  $110 - 5 H/D$ .

Piers laid with 1 to 2 natural cement mortar,  $140 - 5\frac{1}{2} H/D$ .

Piers laid with 1 to 3 Portland cement mortar,  $200 - 6 H/D$ .

$H$  = height;  $D$  = least horizontal dimension, in feet.

**Thickness of Foundation Walls.** (Kidder.)

Height of Building.	Dwellings, Hotels, etc.		Warehouses.	
	Brick.	Stone.	Brick.	Stone.
	Inches.	Inches.	Inches.	Inches.
Two stories.....	12 or 16	20	16	20
Three stories.....	16	20	20	24
Four stories.....	20	24	24	28
Five stories.....	24	28	24	28
Six stories.....	28	32	28	32

**MASONRY.**

**Allowable Pressures on Masonry in Tons per Square Foot.** (Kidder.)

Different Cities.*	(1)	(2)	(3)	(4)	(5)	(6)	(7)
Granite, cut.....	60	.....	72-172	.....	.....	.....	40
Marble and limestone, cut.....	40	.....	50-165	.....	.....	.....	.....
Sandstone, hard, cut.....	30	.....	28-115	.....	.....	.....	12
Hard-burned brick in Portland cement.....	.....	.....	18	12 $\frac{1}{2}$	15	.....	.....
Hard-burned brick in natural cement.....	15	9	15	9	.....	15	9
Hard-burned brick in cement and lime.....	12	.....	11 $\frac{1}{2}$	.....	11 $\frac{1}{2}$	12	.....
Hard-burned brick in lime mortar.....	8	6	8	6 $\frac{1}{2}$	11	8	8
Pressed brick in Portland cement.....	12	.....	.....	.....	.....	.....	.....
Pressed brick in natural cement.....	.....	9	.....	.....	.....	.....	12
Rubble stone in natural cement.....	.....	5	8	.....	.....	10	12
In foundations:							
Dimension stone.....	.....	6	.....	5-7	.....	.....	30
Portland cement concrete.....	.....	4	15	.....	.....	15	10
Natural cement concrete.....	.....	.....	8	4	.....	.....	4

\* From building laws, (1) Boston, 1897; (2) Buffalo, 1897; (3) New York, 1899; (4) Chicago, 1893; (5) St. Louis, 1897; (6) Philadelphia, 1899; (7) Denver, 1898.

**Crushing Strength of 12-in. Cubes of Concrete.** (Kidder.) — Pounds per square foot. The concrete was made of 1 part Portland cement, 2 parts sand, with average concrete stone and gravel, as below.

	10 days.	45 days.	3 mos.	6 mos.	1 year.
6 parts stone.....	130,750	172,325	324,875	361,600	440,040
3 parts stone, 3 gravel.....	136,750	266,962	.....	298,037	396,200
4 parts stone, 2 gravel.....	.....	.....	.....	.....	408,300
6 parts (3/4 stone, 1/4 granolithic).....	.....	.....	.....	.....	388,700
6 parts average gravel.....	99,900	234,475	385,612	265,550	406,700
6 parts coarse stone, no fine.....	.....	.....	234,475	220,350	266,300

**Reinforced Concrete.**—The building laws of New York, St. Louis, Cleveland and Buffalo, and the National Board of Fire Underwriters agree in prescribing the following as the maximum allowable working stresses:

Extreme fiber stress in compression in concrete .....	500 lbs. per sq. in.
Shearing stress in concrete.....	50 " "
Direct compression in concrete.....	350 " "
Adhesion of steel to concrete.....	50 " "
Tensile stress in steel.....	16,000 " "
Shearing stress in steel.....	10,000 " "

**BEAMS AND GIRDERS.**

**Safe Loads on Beams.** — Uniformly distributed load:

$$\text{Safe load in lbs.} = \frac{2 \times \text{breadth} \times \text{square of depth} \times A}{\text{span in feet}}$$

$$\text{Breadth in inches} = \frac{\text{span in feet} \times \text{load}}{2 \times \text{square of depth} \times A}$$

The depth is taken in inches. The coefficient *A*, is <sup>1</sup>/<sub>18</sub> the maximum fiber stress for safe loads, and is the safe load for a beam 1 in. square, 1 ft. span. The following values of *A* are given by Kidder as one-third of the breaking weight of timber of the quality used in first-class buildings. The values for stones are based on a factor of safety of six.

**VALUES FOR A. — COEFFICIENT FOR BEAMS.**

Cast iron.....	308	Pine, Texas yellow.....	90
Wrought iron.....	666	Spruce.....	70
Steel.....	888	Whitewood (poplar).....	65
<b>American Woods:</b>		Redwood (California).....	60
Chestnut.....	60	Bluestone flagging (Hudson River).....	25
Hemlock.....	55	Granite, average.....	17
Oak, white.....	75	Limestone.....	14
Pine, Georgia yellow.....	100	Marble.....	17
Pine, Oregon.....	90	Sandstone.....	8 to 11
Pine, red or Norway.....	70	Slate.....	50
Pine, white, Eastern.....	60		
Pine, white, Western.....	65		

**Safe Loads in Tons, Uniformly Distributed, for White-oak Beams.**

(In accordance with the Building Laws of Boston.)

Formula:  $W = \frac{4 PBD^2}{3 L}$ .  
*W* = safe load in pounds; *P*, extreme fiber-stress = 1000 lbs. per square inch, for white oak; *B*, breadth in inches; *D*, depth in inches; *L*, distance between supports in inches.

Size of Timber.	Distance between Supports in Feet.														
	6	8	10	11	12	14	15	16	17	18	19	21	23	25	26
	Safe Load in Tons of 2000 Pounds.														
2×6	0.67	0.50	0.40	0.36	0.33	0.29	0.27	0.25	0.24	0.22	...	...	...	...	...
2×8	1.19	0.89	0.71	0.65	0.59	0.51	0.47	0.44	0.42	0.40	0.37	0.34	0.31	0.28	...
2×10	1.85	1.39	1.11	1.01	0.93	0.79	0.74	0.69	0.65	0.62	0.58	0.53	0.48	0.43	0.43
2×12	2.67	2.06	1.60	1.45	1.33	1.14	1.07	1.00	0.94	0.89	0.84	0.76	0.70	0.64	0.62
3×6	1.00	0.75	0.60	0.55	0.50	0.43	0.40	0.37	0.35	0.33	0.32	0.29	0.26	...	...
3×8	1.78	1.33	1.07	0.97	0.89	0.76	0.71	0.67	0.63	0.59	0.56	0.51	0.46	0.43	0.41
3×10	2.78	2.08	1.67	1.52	1.39	1.19	1.11	1.04	0.98	0.93	0.88	0.79	0.72	0.67	0.64
3×12	4.00	3.00	2.40	2.18	2.00	1.71	1.60	1.50	1.41	1.33	1.26	1.14	1.04	0.96	0.92
3×14	5.45	4.08	3.27	2.97	2.72	2.37	2.18	2.04	1.92	1.82	1.72	1.56	1.42	1.31	1.25
3×16	7.11	5.33	4.27	3.88	3.56	3.05	2.84	2.62	2.51	2.37	2.25	2.03	1.86	1.71	1.64
4×10	3.70	2.78	2.22	2.02	1.85	1.59	1.48	1.39	1.31	1.23	1.17	1.06	0.97	0.89	0.85
4×12	5.33	4.00	3.20	2.91	2.67	2.29	2.13	2.00	1.88	1.78	1.68	1.52	1.39	1.28	1.23
4×14	7.26	5.44	4.36	3.96	3.63	3.11	2.90	2.72	2.56	2.42	2.29	2.07	1.90	1.74	1.68
4×16	9.48	7.11	5.69	5.17	4.74	4.06	3.79	3.56	3.35	3.16	3.00	2.71	2.47	2.28	2.19
4×18	12.00	9.00	7.20	6.55	6.00	5.14	4.80	4.50	4.24	4.00	3.79	3.43	3.13	2.88	2.77

For other kinds of wood than white oak multiply the figures in the table by a figure selected from those given below (which represent the



safe stress per square inch on beams of different kinds of wood according to the building laws of the cities named) and divide by 1000.

	Hemlock.	Spruce.	White Pine.	Oak.	Yellow Pine.
New York.....	800	900	900	1100	1100*
Boston.....	.....	750	750	1000†	1250
Chicago.....	.....	.....	900	1080	1440

\* Georgia pine.

† White oak.

**Maximum Permissible Stresses in Structural Materials used in Buildings.** (Building Ordinances of the City of Chicago, 1893.) — Cast iron, crushing stress: For plates, 15,000 lbs. per square inch; for lintels, brackets, or corbels, compression 13,500 lbs. per square inch, and tension 3000 lbs. per square inch. For girders, beams, corbels, brackets, and trusses, 16,000 lbs. per square inch for steel and 12,000 lbs. for iron.

For plate girders:

Flange area = maximum bending moment in ft.-lbs.  $\div$  (CD).

D = distance between center of gravity of flanges in feet.

C = 13,500 for steel, 10,000 for iron.

Web area = maximum shear  $\div$  C.

C = 10,000 for steel; 6,000 for iron.

For rivets in single shear per square inch of rivet area:

If shop-driven, steel, 9000 lbs., iron, 7500 lbs.; if field-driven, steel, 7500 lbs., iron, 6000 lbs.

For timber girders:  $S = cbd^2 \div l$ .

b = breadth of beam in inches, d = depth of beam in inches, l = length of beam in feet, c = 160 for long-leaf yellow pine, 120 for oak, 100 for white or Norway pine.

## WALLS.

**Thickness of Walls of Buildings.** — Kidder gives the following general rule for mercantile buildings over four stories in height:

For brick equal to those used in Boston or Chicago, make the thickness of the three upper stories 16 ins., of the next three below 20 ins., the next three 24 ins., and the next three 28 ins. For a poorer quality of material make only the two upper stories 16 ins. thick, the next three 20 ins. and so on down.

In buildings less than five stories in height the top story may be 12 ins. in thickness.

**THICKNESS OF WALLS IN INCHES, FOR MERCANTILE BUILDINGS AND FOR ALL BUILDINGS OVER FIVE STORIES IN HEIGHT.** (The figures show the range of the thicknesses required by the ordinances of eight different cities. — Condensed from Kidder.)

Stories High.	Stories.											
	1st.	2d.	3d.	4th.	5th.	6th.	7th.	8th.	9th.	10th	11th	12th
2	12-18	12-13										
3	13-20	12-18	12-16									
4	16-22	16-18	12-18	12-16								
5	18-22	16-22	16-20	12-20	12-16							
6	20-26	18-22	16-22	16-20	13-20	12-16						
7	20-28	20-26	18-24	16-22	16-20	13-20	12-17					
8	22-32	20-28	20-26	18-24	16-22	16-20	13-20	12-17				
9	24-32	24-32	20-28	20-26	20-24	16-22	16-20	16-20	12-17			
10	24-36	24-32	24-32	20-28	20-26	20-24	16-22	16-20	16-20	12-17		
11	28-36	28-36	24-32	24-30	24-28	20-26	20-24	20-22	16-20	16-20	13-17	
12	28-40	28-36	28-36	24-32	24-32	24-28	20-26	20-24	20-22	16-20	16-20	13-17

(Extract from the Building Laws of the City of New York, 1893.)

**Walls of Warehouses, Stores, Factories, and Stables.** — 25 feet or less in width between walls, not less than 12 in. to height of 40 ft. If 40 to 60 ft. in height, not less than 16 in. to 40 ft., and 12 in. thence to top;

- 60 to 80 ft. in height, not less than 20 in. to 25 ft., and 16 in. thence to top;
  - 75 to 85 ft. in height, not less than 24 in. to 20 ft.; 20 in. to 60 ft., and 16 in. to top;
  - 85 to 100 ft. in height, not less than 28 in. to 25 ft.; 24 in. to 50 ft.; 20 in. to 75 ft., and 16 in. to top;
- Over 100 ft. in height, each additional 25 ft. in height, or part thereof, next above the curb, shall be increased 4 inches in thickness, the upper 100 feet remaining the same as specified for a wall of that height.

If walls are over 25 feet apart, the bearing-walls shall be 4 inches thicker than above specified for every 12½ feet or fraction thereof that said walls are more than 25 feet apart.

**Strength of Floors, Roofs, and Supports.**

	Floors calculated to bear safely per sq. ft., in addition to their own wt.
Floors of dwelling, tenement, apartment-house or hotel, not less than.....	70 lbs.
Floors of office-building, not less than.....	100 "
Floors of public-assembly building, not less than .....	120 "
Floors of store, factory, warehouse, etc., not less than.....	150 "
Roofs of all buildings, not less than.....	50 "

Every floor shall be of sufficient strength to bear safely the weight to be imposed thereon, in addition to the weight of the materials of which the floor is composed.

**Columns and Posts.** — The strength of all columns and posts shall be computed according to Gordon's formulæ, and the crushing weights in pounds, to the square inch of section, for the following-named materials, shall be taken as the coefficients in said formulæ, namely: Cast iron, 80,000; wrought or rolled iron, 40,000; rolled steel, 48,000; white pine and spruce, 3500; pitch or Georgia pine, 5000; American oak, 6000. The breaking strength of wooden beams and girders shall be computed according to the formulæ in which the constants for transverse strains for central load shall be as follows, namely: Hemlock, 400; white pine, 450; spruce, 450; pitch or Georgia pine, 550; American oak, 550; and for wooden beams and girders carrying a uniformly distributed load the constants will be doubled. The factors of safety shall be as one to four for all beams, girders, and other pieces subject to a transverse strain; as one to four for all posts, columns, and other vertical supports when of wrought iron or rolled steel; as one to five for other materials, subject to a compressive strain; as one to six for tie-rods, tie-beams, and other pieces subject to a tensile strain. Good, solid, natural earth shall be deemed to sustain safely a load of four tons to the superficial foot, or as otherwise determined by the superintendent of buildings, and the width of footing-courses shall be at least sufficient to meet this requirement. In computing the width of walls, a cubic foot of brickwork shall be deemed to weigh 115 lbs. Sandstone, white marble, granite, and other kinds of building-stone shall be deemed to weigh 160 lbs. per cubic foot. The safe-bearing load to apply to good brickwork shall be taken at 8 tons per superficial foot when good lime mortar is used, 11½ tons per superficial foot when good lime and cement mortar mixed is used, and 15 tons per superficial foot when good cement mortar is used.

**Fire-proof Buildings — Iron and Steel Columns.** — All cast-iron, wrought-iron, or rolled-steel columns shall be made true and smooth at both ends, and shall rest on iron or steel bed-plates, and have iron or steel cap-plates, which shall also be made true. All iron or steel trimmer-beams, headers, and tail-beams shall be suitably framed and connected together, and the iron girders, columns, beams, trusses, and all other iron-work of all floors and roofs shall be strapped, bolted, anchored, and connected together, and to the walls, in a strong and substantial manner. Where beams are framed into headers, the angle-irons, which are bolted to the tail-beams, shall have at least two bolts for all beams over 7 inches in depth, and three bolts for all beams 12 inches and over in depth, and these bolts shall not be less than ¾ inch in diameter. Each one of such

angles or knees, when bolted to girders, shall have the same number of bolts as stated for the other leg. The angle-iron in no case shall be less in thickness than the header or trimmer to which it is bolted, and the width of angle in no case shall be less than one third the depth of beam, excepting that no angle-knee shall be less than  $2\frac{1}{2}$  inches wide, nor required to be more than 6 inches wide. All wrought-iron or rolled-steel beams 8 inches deep and under shall have bearings equal to their depth, if resting on a wall; 9 to 12 inch beams shall have a bearing of 10 inches, and all beams more than 12 inches in depth shall have bearings of not less than 12 inches if resting on a wall. Where beams rest on iron supports, and are properly tied to the same, no greater bearings shall be required than one third of the depth of the beams. Iron or steel floor-beams shall be so arranged as to spacing and length of beams that the load to be supported by them, together with the weights of the materials used in the construction of the said floors, shall not cause a deflection of the said beams of more than  $\frac{1}{30}$  of an inch per linear foot of span; and they shall be tied together at intervals of not more than eight times the depth of the beam.

Under the ends of all iron or steel beams, where they rest on the walls, a stone or cast-iron template shall be built into the walls. Said template shall be 8 inches wide in 12-inch walls, and in all walls of greater thickness said template shall be 12 inches wide; and such templates, if of stone, shall not be in any case less than  $2\frac{1}{2}$  inches in thickness, and no template shall be less than 12 inches long.

No cast-iron post or columns shall be used in any building of a less average thickness of shaft than three quarters of an inch, nor shall it have an unsupported length of more than twenty times its least lateral dimensions or diameter. No wrought-iron or rolled-steel column shall have an unsupported length of more than thirty times its least lateral dimensions or diameter, nor shall its metal be less than one fourth of an inch in thickness.

**Lintels, Bearings and Supports.** — All iron or steel lintels shall have bearings proportionate to the weight to be imposed thereon, but no lintel used to span any opening more than 10 feet in width shall have a bearing less than 12 inches at each end, if resting on a wall; but if resting on an iron post, such lintel shall have a bearing of at least 6 inches at each end, by the thickness of the wall to be supported.

**Strains on Girders and Rivets.** — Rolled iron or steel beam girders, or riveted iron or steel plate girders used as lintels or as girders, carrying a wall or floor or both, shall be so proportioned that the loads which may come upon them shall not produce strains in tension or compression upon the flanges of more than 12,000 lbs. for iron, nor more than 15,000 lbs. for steel per square inch of the gross section of each of such flanges, nor a shearing strain upon the web-plate of more than 6000 lbs. per square inch of section of such web-plate, if of iron, nor more than 7000 pounds if of steel; but no web-plate shall be less than  $\frac{1}{4}$  inch in thickness. Rivets in plate girders shall not be less than  $\frac{5}{8}$  inch in diameter, and shall not be spaced more than 6 inches apart in any case. They shall be so spaced that their shearing strains shall not exceed 9000 lbs. per square inch, on their diameter, multiplied by the thickness of the plates through which they pass. The riveted plate girders shall be proportioned upon the supposition that the bending or chord strains are resisted entirely by the upper and lower flanges, and that the shearing strains are resisted entirely by the web-plate. No part of the web shall be estimated as flange area, nor more than one half of that portion of the angle-iron which lies against the web. The distance between the centers of gravity of the flange areas will be considered as the effective depth of the girder.

The building laws of the city of New York contain a great amount of detail in addition to the extracts above, and penalties are provided for violation. See An Act creating a Department of Buildings, etc., Chapter 275, Laws of 1892. Pamphlet copy published by Baker, Voorhies & Co., New York.

### FLOORS.

**Maximum Load on Floors.** (*Eng'g*, Nov. 18, 1892, p. 644.) — Maximum load per square foot of floor surface due to the weight of a dense crowd. Considerable variation is apparent in the figures given by many authorities, as the following table shows:



Authorities.	Weight of Crowd, lbs. per sq. ft.
French practice, quoted by Trautwine and Stoney .....	41
Hatfield ("Transverse Strains," p. 80).....	70
Mr. Page, London, quoted by Trautwine.....	84
Maximum load on American highway bridges according to Waddell's general specifications.....	100
Mr. Nash, architect of Buckingham Palace.....	120
Experiments by Prof. W. N. Kernot, at Melbourne .....	126
Experiments by Mr. B. B. Stoney ("On Stresses," p. 617)	143.1
Experiments by Prof. L. J. Johnson, <i>Eng. News</i> , April 14, 1904.....	147.4 134.2 to 156.9

The highest results were obtained by crowding a number of persons previously weighed into a small room, the men being tightly packed so as to resemble such a crowd as frequently occurs on the stairways and platforms of a theatre or other public building.

Safe Allowances for Floor Loads. (Kidder.)	Lbs. per square foot
For dwellings, sleeping and lodging rooms.....	40 lbs.
For schoolrooms.....	50 "
For offices, upper stories.....	60 "
For offices, first story.....	80 "
For stables and carriage houses.....	65 "
For banking rooms, churches and theaters.....	80 "
For assembly halls, dancing halls, and the corridors of all public buildings, including hotels.....	120 "
For drill rooms.....	150 "
For ordinary stores, light storage, and light manufactur- ing.....	120* "

\* Also to sustain a concentrated load at any point of 4000 lbs.

### STRENGTH OF FLOORS.

(From circular of the Boston Manufacturers' Mutual Insurance Co.)

The tables on p. 1393 were prepared by C. J. H. Woodbury, for determining safe loads on floors. Care should be observed to select the figure giving the greatest possible amount and concentration of load as the one which may be put upon any beam or set of floor-beams; and in no case should beams be subjected to greater loads than those specified, unless a lower factor of safety is warranted under the advice of a competent engineer. These tables are computed for beams one inch in width, because the strength of beams increases directly as the width when the beams are broad enough not to cripple.

Beams or heavy timbers used in the construction of a factory or warehouse should not be painted, varnished or oiled. filled or encased in impervious concrete, air-proof plastering, or metal for at least three years, lest fermentation should destroy them by what is called "dry rot."

It is, on the whole, safer to make floor-beams in two parts with a small open space between, so that proper ventilation may be secured.

These tables apply to distributed loads, but the first can be used in respect to floors which may carry concentrated loads by using half the figure given in the table, since a beam will bear twice as much load when evenly distributed over its length as it would if the load was concentrated in the center of the span.

The weight of the floor should be deducted from the figure given in the table, in order to ascertain the net load which may be placed upon any floor. The weight of spruce may be taken at 36 lbs. per cubic foot, and that of Southern pine at 48 lbs. per cubic foot.

Table I was computed upon a working modulus of rupture of Southern pine of 2160 lbs., using a factor of safety of six. It can also be applied to ascertaining the strength of spruce beams if the figures given in the table are multiplied by 0.78; or in designing a floor to be sustained by spruce beams, multiply the required load by 1.28, and use the dimensions as given by the table.

EXAMPLE.—Required the safe load per square foot of floor, which may be safely sustained by a floor on Southern pine 10 × 14 in. beams, 8 ft. on centers, and 20 ft. span. In Table I a 1 × 14 in. beam, 20 ft.

span, will sustain 118 lbs. per foot of span; and for a beam 10 ins. wide the load would be 1180 lbs. per foot of span, or  $147\frac{1}{2}$  lbs. per sq. ft. of floor for Southern-pine beams. From this should be deducted the weight of the floor,  $17\frac{1}{2}$  lbs. per sq. ft., leaving 130 lbs. per sq. ft. as a safe load. If the beams are of spruce, multiply  $147\frac{1}{2}$  by 0.78, reducing the load to 115 lbs. Deducting the weight of the floor, 16 lbs., leaves the safe net load as 90 lbs. per sq. ft. for spruce beams.

Table II applies to floors whose strength must be in excess of that necessary to sustain the weight, in order to meet the conditions of delicate or rapidly moving machinery, to the end that the vibration or distortion of the floor may be reduced to the least practicable limit.

In the table the limit is that of a load which would cause a bending of the beams to a curve of which the average radius would be 1250 ft.

This table is based upon a modulus of elasticity obtained from observations upon the deflection of loaded storehouse floors, and is taken at 2,000,000 lbs. for Southern pine; the same table can be applied to spruce, whose modulus of elasticity is taken as 1,200,000 lbs., if six tenths of the load for Southern pine is taken as the proper load for spruce; or, in the matter of designing, the load should be increased one and two thirds times, and the dimension of timbers for this increased load as found in the table should be used for spruce.

It can also be applied to beams and floor-timbers supported at each end and in the middle, remembering that the deflection of a beam supported in that manner is only 0.4 that of a beam of equal span which rests at each end; that is to say, the floor-planks are  $2\frac{1}{2}$  times as stiff, cut two bays in length, as they would be if cut only one bay in length. When a floor-plank two bays in length is evenly loaded,  $\frac{3}{16}$  of the load on the plank is sustained by the beam at each end of the plank, and  $\frac{10}{16}$  by the beam under the middle of the plank; so that for a completed floor  $\frac{3}{8}$  of the load would be sustained by the beams under the joints of the plank, and  $\frac{5}{8}$  of the load by the beams under the middle of the plank: this is the reason of the importance of breaking joints in a floor-plank every 3 ft. in order that each beam shall receive an identical load. If it were not so,  $\frac{3}{8}$  of the whole load upon the floor would be sustained by every other beam, and  $\frac{5}{8}$  of the load by the alternate beams.

Repeating the former example for the load on a mill floor on Southern-pine beams  $10 \times 14$  ins., and 20 ft. span, 8 ft. centers: In Table II a  $1 \times 14$  in. beam should receive 61 lbs. per foot of span, or 75 lbs. per sq. ft. of floor, for Southern-pine beams. Deducting the weight of the floor,  $17\frac{1}{2}$  lbs. per sq. ft., 57 lbs. per sq. ft. is the advisable load.

If the beams are of spruce, the result of 75 lbs. should be multiplied by 0.6, reducing the load to 45 lbs. The weight of the floor, in this instance amounting to 16 lbs., would leave the net load as 29 lbs. for spruce beams.

If the beams were two spans in length, they could, under these conditions, support two and a half times as much load with an equal amount of deflection, unless such load should exceed the limit of safe load as found by Table I, as would be the case under the conditions of this problem.

**Maximum Spans for 1, 2 and 3 Inch Plank.** (*Am. Mach.*, Feb. 11, 1904.) — Let  $w$  = load per sq. ft.;  $l$  = length in ins.;  $W = wl/12$ ;  $S$  = safe fiber stress, using a factor of safety of 10;  $b$  = width of plank;  $d$  = thickness;  $p$  = deflection,  $E$  = coefficient of elasticity,  $I$  = moment of inertia =  $\frac{1}{12}bd^3$ .

Then  $Wl/8 = Sbd^2/6$ ;  $s = 5Wl^3 \div 384EI$ . Taking  $S$  at 1200 lbs.,  $E$  at 850,000 and  $s = l \div 360$  for long-leaf yellow pine, the following figures for maximum span, in inches, are obtained:

Uniform load, lbs. per sq. ft.	40	60	80	100	150	200	250	300
1-in. plank	For strength . . .	75	61	53	48	39	33	... ..
	For deflection . . .	37	33	30	28	24	22	... ..
2-in. plank	For strength . . .	151	123	107	96	78	67	60 55
	For deflection . . .	75	66	60	55	48	44	41 38
3-in. plank	For strength . . .	227	185	161	144	117	101	91 83
	For deflection . . .	113	99	90	83	73	66	61 58

For white oak  $S$  may be taken at 1000 and  $E$  at 550,000; for Canadian spruce,  $S = 800$ ,  $E = 600,000$ ; for hemlock,  $S = 600$ ,  $E = 450,000$ .

**I. Safe Distributed Loads upon Southern-pine Beams One Inch in Width.**

(C. J. H. Woodbury.)

(If the load is concentrated at the center of the span, the beams will sustain half the amount given in the table.)

Span, feet.	Depth of Beam in inches.															
	2	3	4	5	6	7	8	9	10	11	12	13	14	15	16	
	Load in pounds per foot of Span.															
5	38	86	154	240	346	470	614	778	960							
6	27	60	107	167	240	327	427	549	667	807						
7	20	44	78	122	176	240	314	397	490	593	705	828				
8	15	34	60	94	135	184	240	304	375	454	540	634	735			
9	.....	27	47	74	107	145	190	240	296	359	427	501	581	667	759	
10	.....	22	38	60	86	118	154	194	240	290	346	406	470	540	614	
11	.....	.....	32	50	71	97	127	161	198	240	286	335	389	446	508	
12	.....	.....	27	42	60	82	107	135	167	202	240	282	327	375	474	
13	.....	.....	.....	36	51	70	90	115	142	172	205	240	278	320	364	
14	.....	.....	.....	31	44	60	78	99	123	148	176	207	240	276	314	
15	.....	.....	.....	27	38	52	68	86	107	129	154	180	209	240	273	
16	.....	.....	.....	.....	34	46	60	76	94	113	135	158	184	211	240	
17	.....	.....	.....	.....	30	41	53	67	83	101	120	140	163	187	217	
18	.....	.....	.....	.....	.....	36	47	60	74	90	107	125	145	167	190	
19	.....	.....	.....	.....	.....	.....	43	54	66	80	96	112	130	150	170	
20	.....	.....	.....	.....	.....	.....	38	49	60	73	86	101	118	135	154	
21	.....	.....	.....	.....	.....	.....	.....	44	54	66	78	92	107	122	139	
22	.....	.....	.....	.....	.....	.....	.....	.....	50	60	71	84	97	112	127	
23	.....	.....	.....	.....	.....	.....	.....	.....	45	55	65	77	89	102	116	
24	.....	.....	.....	.....	.....	.....	.....	.....	.....	50	60	70	82	94	107	
25	.....	.....	.....	.....	.....	.....	.....	.....	.....	46	55	65	75	86	98	

**II. Distributed Loads upon Southern-pine Beams Sufficient to Produce Standard Limit of Deflection.**

Span, feet.	Depth of Beam in inches.																Deflection, inches.
	2	3	4	5	6	7	8	9	10	11	12	13	14	15	16		
	Load in pounds per foot of Span.																
5	3	10	23	44	77	122	182	259								.0300	
6	2	7	16	31	53	85	126	180	247							.0432	
7	.....	5	12	23	39	62	93	132	181	241						.0588	
8	.....	4	9	17	30	48	71	101	139	185	240	305				.0768	
9	.....	.....	7	14	24	38	56	80	110	146	190	241	301			.0972	
10	.....	.....	6	11	19	30	46	65	89	118	154	195	244	300		.1200	
11	.....	.....	.....	9	16	25	38	54	73	98	127	161	202	248	301	.1452	
12	.....	.....	.....	.....	13	21	32	45	62	82	107	136	169	208	253	.1728	
13	.....	.....	.....	.....	11	18	27	38	53	70	91	116	144	178	215	.2028	
14	.....	.....	.....	.....	.....	16	23	33	45	60	78	100	124	153	186	.2352	
15	.....	.....	.....	.....	.....	14	20	29	40	53	68	87	108	133	162	.2700	
16	.....	.....	.....	.....	.....	.....	18	25	35	46	60	76	95	117	147	.3072	
17	.....	.....	.....	.....	.....	.....	16	22	31	41	53	68	84	104	126	.3468	
18	.....	.....	.....	.....	.....	.....	.....	20	27	37	47	60	75	93	112	.3888	
19	.....	.....	.....	.....	.....	.....	.....	18	25	33	43	54	68	83	101	.4332	
20	.....	.....	.....	.....	.....	.....	.....	.....	22	30	38	49	61	75	91	.4800	
21	.....	.....	.....	.....	.....	.....	.....	.....	20	27	35	44	55	68	83	.5292	
22	.....	.....	.....	.....	.....	.....	.....	.....	.....	24	32	40	50	62	75	.5808	
23	.....	.....	.....	.....	.....	.....	.....	.....	.....	22	29	37	46	57	69	.6348	
24	.....	.....	.....	.....	.....	.....	.....	.....	.....	.....	27	34	42	52	63	.6912	
25	.....	.....	.....	.....	.....	.....	.....	.....	.....	.....	25	31	39	48	58	.7500	

**Mill Columns.**—Timber posts offer more resistance to fire than iron pillars, and have generally displaced them in millwork. Experiments



at the U. S. Arsenal at Watertown, Mass., show that sound timber posts of the proportions customarily used in millwork yield by direct crushing, the strength being directly as the area at the smallest part. The columns yielded at about 4500 lbs. per sq. in., confirming the general practice of allowing 600 lbs. per sq. in. as a safe load. Square columns are one fourth stronger than round ones of the same diameter.

### COST OF BUILDINGS.

**Approximate Cost of Mill Buildings.**—Chas. T. Main (*Eng. News*, Jan. 27, 1910) gives a series of diagrams of the cost in New England Jan., 1910, per sq. ft. of floor space of different sizes of brick mill buildings, one to six stories high, of the type known as "slow-burning," calculated for total floor loads of about 75 lbs. per sq. ft. Figures taken from the diagrams are given in the table below. The costs include ordinary foundations and plumbing, but no heating, sprinklers or lighting.

#### COST OF BRICK MILL BUILDINGS PER SQ. FT. OF FLOOR AREA.

Length, feet.	50	100	150	200	250	300	350	400	500
One Story.									
Width 25 ft.	\$1.90	\$1.66	\$1.58	\$1.54	\$1.51	\$1.49	\$1.48	\$1.47	\$1.46
50	1.52	1.29	1.21	1.18	1.16	1.15	1.14	1.13	1.13
75	1.41	1.21	1.12	1.08	1.06	1.04	1.03	1.02	1.02
125	1.32	1.09	1.02	0.98	0.96	0.94	0.94	0.93	0.92
Two Stories.									
25	2.00	1.62	1.52	1.47	1.44	1.41	1.39	1.38	1.36
50	1.50	1.21	1.13	1.09	1.06	1.05	1.04	1.03	1.02
75	1.34	1.08	1.01	0.97	0.94	0.92	0.92	0.91	0.90
125	1.22	0.97	0.90	0.86	0.84	0.82	0.81	0.80	0.80
Three Stories.									
25	1.98	1.57	1.47	1.42	1.39	1.38	1.36	1.35	1.34
50	1.47	1.17	1.07	1.03	1.01	1.00	0.98	0.98	0.98
75	1.30	1.05	0.98	0.94	0.91	0.89	0.88	0.87	0.86
125	1.18	0.93	0.86	0.82	0.80	0.78	0.77	0.76	0.76
Four Stories.									
25	2.00	1.61	1.50	1.45	1.42	1.40	1.38	1.37	1.36
50	1.38	1.17	1.10	1.05	1.02	1.00	1.00	0.99	0.98
75	1.32	1.08	0.97	0.93	0.90	0.88	0.88	0.87	0.87
125	1.20	0.93	0.85	0.81	0.78	0.77	0.76	0.75	0.74
Six Stories.									
25	2.10	1.72	1.57	1.51	1.48	1.46	1.44	1.43	1.42
50	1.53	1.21	1.12	1.08	1.05	1.04	1.03	1.02	1.02
75	1.35	1.08	0.98	0.94	0.92	0.90	0.89	0.88	0.86
125	1.22	0.96	0.86	0.82	0.79	0.78	0.77	0.76	0.76

The cost per sq. ft. of a building 100 ft. wide will be about midway between that of one 75 ft. wide and one 125 ft. wide, and the cost of a five-story building about midway between the costs of a four- and a six-story. The data for estimating the above costs are as follows:

		Stories High.					
		1	2	3	4	5	6
Foundations, including excavations, cost per lin. ft.	Outside walls...	\$2.00	\$2.90	\$3.80	\$4.70	\$5.60	\$6.50
	Inside walls...	1.75	2.25	2.80	3.40	3.90	4.50
Brick walls, cost per sq. ft. of surface...	Outside walls...	0.40	0.44	0.47	0.50	0.53	0.57
	Inside walls...	0.40	0.40	0.40	0.43	0.45	0.47

Columns, including piers and castings, cost each \$15.

*Assumed Height of Stories.*—From ground to first floor, 3 ft. Buildings

25 ft. wide, stories 13 ft. high; 50 ft. wide, 14 ft. high; 75 ft. wide, 15 ft. high; 100 ft. and 125 ft. wide, 16 ft. high.

Floors, 32 cts. per sq. ft. of gross floor space not including columns. Columns included, 38 cts.

Roof, 25 cts. per sq. ft., not including columns. Columns included 30 cts. Roof to project 18 ins. all around buildings.

Stairways, including partitions, \$100 each flight. Two stairways and one elevator tower for buildings up to 150 ft. long; two stairways and two elevator towers for buildings up to 300 ft. long. In buildings over two stories, three stairways and three elevator towers for buildings over 300 ft. long.

In buildings over two stories, plumbing \$75 for each fixture including piping and partitions. Two fixtures on each floor up to 5000 sq. ft. of floor space and one fixture for each additional 5000 sq. ft. of floor or fraction thereof.

*Modifications of the above Costs:*

1. If the soil is poor or the conditions of the site are such as to require more than ordinary foundations, the cost will be increased.

2. If the building is to be used for ordinary storage purposes with low stories and no top floors, the cost will be decreased from about 10% for large low buildings to 25% for small high ones, about 20% usually being a fair allowance.

3. If the building is to be used for manufacturing and is substantially built of wood, the cost will be decreased from about 6% for large one-story buildings to 33% for high small buildings; 15% would usually be a fair allowance.

4. If the building is to be used for storage with low stories and built substantially of wood, the cost will be decreased from 13% for large one-story buildings to 50% for small high buildings; 30% would usually be a fair allowance.

5. If the total floor loads are more than 75 lbs. per sq. ft. the cost is increased.

6. For office buildings, the cost must be increased to cover architectural features on the outside and interior finish.

Reinforced-concrete buildings designed to carry floor loads of 100 lbs. per sq. ft. or less will cost about 25% more than the slow-burning type of mill construction.

**ELECTRICAL ENGINEERING.\*****STANDARDS OF MEASUREMENT.****C.G.S. (Centimeter, Gramme, Second) or "Absolute" System of Physical Measurements:**

Unit of space or distance	= 1 centimeter, cm.;
Unit of mass	= 1 gramme, gm.;
Unit of time	= 1 second, sec.;
Unit of velocity = space ÷ time	= 1 centimeter in 1 second;
Unit of acceleration = change of 1 unit of velocity in 1 second;	
Acceleration due to gravity,	= 980.665 centimeters per sec. per sec.
Unit of force = 1 dyne =	$\frac{1}{980.665}$ gm. = $\frac{0.00220462}{980.665}$ lb. = 0.000022481 lb.

A dyne is that force which, acting on a mass of one gramme during one second, will give it a velocity of one centimeter per second. The weight of one gramme in latitude 40° to 45° is about 980 dynes, at the equator 973 dynes, and at the poles nearly 984 dynes. Taking the value of  $g$ , the acceleration due to gravity, in British measures at 32.1740 feet per second at lat. 45° at the sea level, and the meter = 39.37 inches, we have

$$1 \text{ gramme} = 32.174 \times 12 \div 0.3937 = 980.665 \text{ dynes.}$$

Unit of work = 1 erg = 1 dyne-centimeter = 0.00000073756 ft.-lb.;

Unit of power = 1 watt = 10 million ergs per second,  
= 0.73756 foot-pound per second.

$$= \frac{0.73756}{550} = \frac{1}{745.7} \text{ horse-power} = 0.0013410 \text{ H.P.}$$

C.G.S. unit magnetic pole is one which reacts on an equal pole at a centimeter's distance with the force of 1 dyne.

C.G.S. unit of magnetic field strength, the *gauss*, is the intensity of field which surrounding unit pole acts on it with a force of 1 dyne.

C.G.S. unit of electro-motive force = the force produced by the cutting of a field of 1 gauss intensity at a velocity of 1 centimeter per second (in a direction normal to the field and to the conductor) by 1 centimeter of conductor. The *volt* is 100,000,000 times this unit.

C.G.S. unit of electrical current = the current in a conductor (located in a plane normal to the field) when each centimeter is urged across a magnetic field of 1 gauss intensity with a force of 1 dyne. One-tenth of this is the *ampere*.

The C.G.S. unit of quantity of electricity is that represented by the flow of 1 C.G.S. unit of current for 1 second. One-tenth of this is the *coulomb*.

**The Practical Units used in Electrical Calculations are:**

*Ampere*, the unit of current strength, or rate of flow, represented by  $I$ .

*Volt*, the unit of electro-motive force, electrical pressure, or difference of potential, represented by  $E$ .

*Ohm*, the unit of resistance, represented by  $R$ .

*Coulomb* (or ampere-second), the unit of quantity,  $Q$ .

*Ampere-hour* = 3600 coulombs,  $Q'$ .

*Watt* (volt-ampere), the unit of power,  $P$ .

*Joule* (or watt-second), the unit of energy or work,  $W$ .

*Farad*, the unit of electrostatic capacity, represented by  $C$ .

*Henry*, the unit of inductance, represented by  $L$ .

Using letters to represent the units, the relations between them may be expressed by the following formulæ, in which  $t$  represents one second and  $T$  one hour:

$$I = \frac{E}{R}, \quad Q = It, \quad Q' = IT, \quad C = \frac{Q}{E}, \quad W = QE, \quad P = IE.$$

As these relations contain no coefficient other than unity, the letters may represent any quantities given in terms of those units. For example, if  $E$  represents the number of volts electro-motive force, and  $R$  the number of ohms resistance in a circuit, then their ratio  $E \div R$  will give the number of amperes current strength in that circuit.

The above six formulæ can be combined by substitution or elimination,

\* In the revision of this chapter the author has had the assistance of Mr. David B. Rushmore.



so as to give the relations between any of the quantities. The most important of these are the following:

$$Q = \frac{E}{R}t, \quad C = \frac{I}{E}t, \quad W = IEt = \frac{E^2}{R}t = I^2Rt = Pt,$$

$$E = IR, \quad R = \frac{E}{I}, \quad P = \frac{E^2}{R} = I^2R = \frac{W}{t} = \frac{QE}{t}.$$

The definitions of these units as adopted at the International Electrical Congress at Chicago in 1893, and as established by Act of Congress of the United States, July 12, 1894, are as follows:

The *ohm* is substantially equal to  $10^9$  (or 1,000,000,000) units of resistance of the C.G.S. system, and is represented by the resistance offered to an unvarying electric current by a column of mercury at 32° F., 14.4521 grammes in mass, of a constant cross-sectional area, and of the length of 106.3 centimeters.

The *ampere* is  $\frac{1}{10}$  of the unit of current of the C.G.S. system, and is the practical equivalent of the unvarying current which when passed through a solution of nitrate of silver in water in accordance with standard specifications deposits silver at the rate of 0.001118 gramme per second.

The *volt* is the electro-motive force that, steadily applied to a conductor whose resistance is one ohm, will produce a current of one ampere, and is practically equivalent to 1000/1434 (or 0.6974) of the electro-motive force between the poles or electrodes of a Clark's cell at a temperature of 15° C., and prepared in the manner described in the standard specifications. [The e.m.f. of a Weston normal cell is 1.0183 volts at 20° C.]

The *coulomb* is the quantity of electricity transferred by a current of one ampere in one second.

The *farad* is the capacity of a condenser charged to a potential of one volt by one coulomb of electricity.

The *joule* is equal to 10,000,000 units of work in the C.G.S. system, and is practically equivalent to the energy expended in one second by an ampere in an ohm.

The *watt* is equal to 10,000,000 units of power in the C.G.S. system, and is practically equivalent to the work done at the rate of one joule per second.

The *henry* is the induction in a circuit when the electro-motive force induced in this circuit is one volt, while the inducing current varies at the rate of one ampere per second.

The ohm, volt, etc., as above defined, are called the "international" ohm, volt, etc., to distinguish them from the "legal" ohm, B.A. unit, etc.

The value of the ohm, determined by a committee of the British Association in 1863, called the B.A. unit, was the resistance of a certain piece of copper wire. The so-called "legal" ohm, as adopted at the International Congress of Electricians in Paris in 1884, was a correction of the B.A. unit, and was defined as the resistance of a column of mercury 1 square millimeter in section and 106 centimeters long, at a temperature of 32° F. 1 legal ohm = 1.0112 B.A. units; 1 international ohm = 1.0023 legal ohm; 1 legal ohm = 0.9977 int. ohm.

#### DERIVED UNITS.

1 megohm	= 1 million ohms;
1 microhm	= 1 millionth of an ohm;
1 milliamper	= $\frac{1}{1000}$ of an ampere;
1 micro-farad	= 1 millionth of a farad.

#### RELATIONS OF VARIOUS UNITS.

1 ampere	= 1 coulomb per second;
1 volt-ampere (direct current)	= 1 watt = 1 volt-coulomb per sec.;
1 watt	= 0.73756 foot-pound per second.
	= 0.00094859 heat-unit per sec. (Fahr.);
	= $\frac{1}{745.7}$ of one horse-power;
1 joule = $10^7$ ergs	= 0.73756 foot-pound,
	= work done by one watt in one sec.,
	= 0.00094859 heat-unit;
	= 0.23904 gram calories;
1 British thermal unit	= 1054.2 joules;
	= 777.54 foot-pounds;
	= 25.200 gram calories;

1 mean gram calorie.....	}	= 4.1834 × 10 <sup>7</sup> ergs* ;
		= 0.0039683 B. T. U. ;
1 kilowatt, or 1000 watts....	}	= 1000/745.7 or 1.3410 horse-powers ;
1 kilowatt-hour.....		= 1.3410 horse-power hours,
1000 volt-ampere hours.....		= 2,655,220 foot-pounds,
1 British Board of Trade unit		= 3415 heat-units ;
1 horse-power.....		= 745.7 watts = 745.7 volt-amperes, = 33,000 foot-pounds per minute.

The ohm, ampere, and volt are defined in terms of one another as follows: Ohm, the resistance of a conductor through which a current of one ampere will pass when the electro-motive force is one volt. Ampere, the quantity of current which will flow through a resistance of one ohm when the electro-motive force is one volt. Volt, the electro-motive force required to cause one ampere to flow through a resistance of one ohm.

**For Methods of Making Electrical Measurements, Testing, etc.,** see "American Handbook for Electrical Engineers"; Karapetoff's "Experimental Electrical Engineering"; Bedell's "Direct and Alternating Current Manual"; 1914 Standardization Rules of A. I. E. E.

**Equivalent Electrical and Mechanical Units.**—H. Ward Leonard published in *The Electrical Engineer*, Feb. 25, 1895, a table of useful equivalents of electrical and mechanical units, from which the table on page 1399 is taken, with some modifications.

### Units of the Magnetic Circuit.

*Unit magnetic pole* is a pole of such strength that when placed at a distance of one centimeter from a similar pole of equal strength it repels it with a force of one dyne.

*Magnetic Moment* is the product of the strength of either pole into the distance between the two poles.

*Intensity of Magnetization* is the magnetic moment of a magnet divided by its volume.

*Intensity of Magnetic Field* is the force exerted by the field upon a unit magnetic pole. The unit is the gauss.

*Gauss* = unit of field strength, or density, symbol H is that intensity of field which acts on a unit pole with a force of one dyne, = one line of force per square centimeter. One gauss produces 1 dyne of force per centimeter length of conductor upon a current of 10 amperes, or an electro-motive force of 1/100,000,000 volt in a centimeter length of conductor when its velocity across the field is 1 centimeter per second. A field of H units is one which acts with H dynes on unit pole, or H lines per square centimeter. A unit magnetic pole has 4π lines of force proceeding from it.

*Maxwell* = unit of magnetic flux, is the amount of magnetism passing through a square centimeter of a field of unit density. Symbol, φ.

In non-magnetic materials a unit of intensity of flux is the same as unit intensity of field. The name maxwell is given to a unit quantity of flux, and one maxwell per square centimeter in non-magnetic materials is the same as the gauss. In magnetic materials the flux produced by the molecular magnets is added to the field (Norris).

*Magnetic Flux*, φ, is equal to the average field intensity multiplied by the cross-sectional area. The unit is the maxwell. Maxwells per square inch = gaussess × 6.45.

*Magnetic Induction*, symbol B, is the flux or the number of magnetic lines per unit of area of cross-section of magnetized material, the area being at every point perpendicular to the direction of the flux. It is equal to the product of the field intensity, H, and the permeability, μ.

*Gilbert* = unit of magnetomotive force, is the amount of M.M.F. that would be produced by a coil of 10 ÷ 4π or 0.7958 ampere-turns. Symbol F.

The M.M.F. of a coil is equal to 1.2566 times the ampere-turns.

If a solenoid is wound with 100 turns of insulated wire carrying a current of 5 amperes, the M.M.F. exerted will be 500 ampere-turns × 1.2566 = 628.3 gilberts.

*Oersted* = unit of magnetic reluctance; a magnetic circuit has a reluctance of 1 oersted when unit m.m.f. produces unit flux. Symbol, R.

*Reluctance* is that quantity in a magnetic circuit which limits the flux

\* Mean of the values of Reynolds and Moorby and of Barnes—Marks & Davis, Steam Tables, 1909.

## Equivalent Values of Electrical, Mechanical and Heat Units

Unit.	Equivalent Value in Other Units.	Unit.	Equivalent Value in Other Units.	Unit.	Equivalent Value in Other Units.
K.W. Hour =	1,000 watt hours. 1,341 horse-power hours. 2,655,200 ft.-lbs. per hour. 3,600,000 joules. 3,415 heat-units. 367,100 kilogram meters. 0.234 lb. carbon oxidized with perfect efficiency. 3.52 lbs. water evap. from and at 212° F. 22.77 lbs. of water raised from 62° F. to 212° F.	H.P. =	745.7 watts. 0.7457 K.W. 33,000 ft.-lbs. per minute. 550 ft.-lbs. per second. 2,546.5 heat-units per hour. 42.44 heat-units per minute. 0.707 heat-units per second. 0.174 lb. carbon oxidized per hour. 2.62 lbs. water evap. per hour from and at 212° F.	Heat-unit =	1,054.2 watt seconds. 777.54 ft.-lbs. 107.5 kilogram meters. 0.0002928 K.W. hour. 0.0003927 H.P. hour. 0.0000685 lb. carbon oxidized. 0.001030 lb. water evap. from and at 212° F.
	1,980,000 ft.-lbs. 2,546.5 heat-units. 273,740 k.g.m. 0.174 lb. carbon oxidized with perfect efficiency. 2.62 lbs. water evaporated from and at 212° F. 17.0 lbs. water raised from 62° F. to 212° F.		Joule =		1 watt second. 0.00000278 K.W. hour. 0.10197 k.g.m. 0.0009486 heat-units. 0.73756 ft.-lb. 1.3558 joules. 0.13826 k.g.m. 0.000003766 K.W. hour. 0.0012861 heat-unit. 0.0000005 H.P. hour.
H.P. Hour =	1,000 watts. 1,3410 horse-power. 2,655,200 ft.-lbs. per hour. 44,254 ft.-lbs. per minute. 737.56 ft.-lbs. per second. 3,415 heat-units per hour. 56.92 heat-units per minute. 0.9486 heat-units per second. 0.234 lb. carbon oxidized per hour. 3.52 lbs. water evap. per hour from and at 212°	Watt =	1 joule per second. 0.001341 H.P. 3.415 heat-units per hour. 0.73756 ft.-lbs. per second. 0.0035 lb. water evap. per hr. 44.254 ft.-lbs. per minute. 8.20 heat-units per sq. ft. per minute. 6,373 ft.-lbs. per sq. ft. per minute. 0.1931 H.P. per sq. ft.	Carbon Oxidized with perfect Efficiency =	14,600 heat-units. 1.11 lbs. Anth'cite coal ox. 2.5 lbs. dry wood oxidized. 22 cu.ft. illuminating-gas. 4.275 K.W. hours. 5.733 H.P. hours. 11,352,000 ft.-lbs. 15.05 lbs. of water evap. from and at 212° F.
	1,000 watt hours. 1,3410 horse-power. 2,655,200 ft.-lbs. per hour. 44,254 ft.-lbs. per minute. 737.56 ft.-lbs. per second. 3,415 heat-units per hour. 56.92 heat-units per minute. 0.9486 heat-units per second. 0.234 lb. carbon oxidized per hour. 3.52 lbs. water evap. per hour from and at 212°		1 Watt per sq. in. =		7.233 ft.-lbs. 0.000003653 H.P. hour. 0.000002724 K.W. hour. 0.009302 heat-unit.



under a given M.M.F. It corresponds to the resistance in the electric circuit.

*Permeance* is the reciprocal of reluctance.

The *reluctivity* of any medium is its specific reluctance, and in the C.G.S. system is the reluctance offered by a cubic centimeter of the body between opposed parallel faces. The reluctivity of nearly all substances, other than the magnetic metals, is sensibly that of vacuum, is equal to unity, and is independent of the flux density.

**Permeability** is the reciprocal of magnetic reluctivity. It is a number and the symbol is  $\mu$ .

Materials differ in regard to the resistance they offer to the passage of lines of force; thus iron is more permeable than air. The permeability of a substance is expressed by a coefficient,  $\mu$ , which denotes its relation to the permeability of air, which is taken as 1. If  $H$  = number of magnetic lines per square centimeter which will pass through an air-space between the poles of a magnet, and  $B$  the number of lines which will pass through a certain piece of iron in that space, then  $\mu = B \div H$ . The permeability varies with the quality of the iron, and the degree of saturation, reaching a practical limit for soft wrought iron when  $B$  = about 18,000 and for cast iron when  $B$  = about 10,000 C.G.S. lines per square centimeter.

The permeability of a number of materials may be determined by means of the table on page 1431.

### ANALOGIES BETWEEN THE FLOW OF WATER AND ELECTRICITY.

#### WATER.

Head, difference of level, in feet.

Difference of pressure, lbs. per sq. in.

Resistance of pipes, apertures, etc., increases with length of pipe, with contractions, roughness, etc.; decreases with increase of sectional area.

Rate of flow, as cubic ft. per second, gallons per min., etc., or volume divided by the time. In the mining regions sometimes expressed in "miners' inches."

Quantity, usually measured in cubic ft. or gallons, but is also equivalent to rate of flow  $\times$  time, as cu. ft. per second for so many hours.

Work, or energy, measured in foot-pounds; product of weight of falling water into height of fall; in pumping, product of quantity in cubic feet into the pressure in lbs. per square foot against which the water is pumped.

Power, rate of work. Horse-power = ft.-lbs. of work in 1 min.  $\div$  33,000. In water flowing in pipes, rate of flow in cu. ft. per second  $\times$  resistance to the flow in lbs. per sq. ft.  $\div$  550.

#### ELECTRICITY.

Volts; electro-motive force; difference of potential;  $E$ , or E.M.F.

Ohms, resistance,  $R$ . Increases directly as the length of the conductor or wire and inversely as its sectional area,  $R \propto l \div s$ . It varies with the nature of the conductor.

Amperes; current; current strength; intensity of current; rate of flow; 1 ampere = 1 coulomb per second.

Amperes =  $\frac{\text{volts}}{\text{ohms}}$ ;  $I = \frac{E}{R}$ ;  $E = IR$ .

Coulomb, unit of quantity,  $Q$ , = rate of flow  $\times$  time, as ampere-seconds. 1 ampere-hour = 3600 coulombs.

Joule, volt-coulomb,  $W$ , the unit of work, = product of quantity by the electro-motive force = volt-ampere-second. 1 joule = 0.7373 foot-pound.

If  $C$  (amperes) = rate of flow, and  $E$  (volts) = difference of pressure between two points in a circuit, energy expended =  $I Et$ , =  $I^2 Rt$ .

Watt, unit of power,  $P$ , = volts  $\times$  amperes, = current or rate of flow  $\times$  difference of potential.

1 watt = 0.7373 foot-pound per sec. = 1/746 of a horse-power.

### ELECTRICAL RESISTANCE.

**Laws of Electrical Resistance.** — The resistance,  $R$ , of any conductor varies directly as its length,  $l$ , and inversely as its sectional area,  $s$ , or  $R \propto l \div s$ .

If  $r$  = the resistance of a conductor 1 unit in length and 1 square unit in sectional area,  $R = rl \div s$ . The common unit of length for electrical

calculations in English measure is the foot, and the unit of area of wires is the circular mil = the area of a circle 0.001 in. diameter. 1 mil-foot = 1 foot long 1 circ.-mil area.

Resistance of 1 mil-foot of soft copper wire at 51° F. = 10 international ohms.

EXAMPLE. — What is the resistance of a wire 1000 ft. long, 0.1 in. diam.? 0.1 in. diam. = 10,000 circ. mils.

$$R = r\ell \div s = 10 \times 1000 \div 10,000 = 1 \text{ ohm.}$$

Specific resistance, also called resistivity, is the resistance of a material of unit length and section as compared with the resistance of soft copper.

Conductivity is the reciprocal of specific resistance, or the relative conducting power compared with copper taken at 100.

Conductance is the reciprocal of resistance.

### Relative Conductivities of Different Metals at 0° and 100° C. (Matthiessen.)

Metals.	Conductivities.		Metals.	Conductivities.	
	At 0° C. At 32° F.	At 100° C. At 212° F.		At 0° C. At 32° F.	At 100° C. At 212° F.
Silver, hard. ....	100	71.56	Tin. ....	12.36	8.67
Copper, hard. ....	99.95	70.27	Lead. ....	8.32	5.86
Gold, hard. ....	77.96	55.90	Arsenic. ....	4.76	3.33
Zinc, pressed. ....	29.02	20.67	Antimony. ....	4.62	3.26
Cadmium. ....	23.72	16.77	Mercury, pure. .	1.60	.....
Platinum, soft. .	18.00	.....	Bismuth. ....	1.245	0.878
Iron, soft. ....	16.80	.....			

**Resistance of Various Metals and Alloys.** — Condensed from a table compiled by H. F. Parshall and H. M. Hobart from different authorities.  $R$  = resistance in ohms per mil foot = resistance per centimeter cube  $\times 6.015$ .  $C$  = per cent increase of resistance per degree C.

	$R$	$C$		$R$	$C$
Aluminum, 99% pure. ....	15.4	0.423	White cast iron. ....	340	
Aluminum, 94; copper, 6. .	17.4	.381	Gray cast iron. ....	684	
Al. bronze, Al 10; Cu, 90 .	75.5	.105	Wrought iron. ....	82.8	
Antimony, compressed. .	211	.389	Soft steel, C, 0.045 . . . . .	63	
Bismuth, compressed. . .	780	.354	Manganese steel, Mn, 12. .	401	.127
Cadmium, pure. ....	60	.419	Nickel steel, Ni, 4.35. . . . .	177	.201
Copper, annealed, (D). . .	9.35	.428	Lead, pure. ....	123	.411
Copper, annealed, (M) . . .	9.54	.388	Manganin,		
Copper, 88; silicon, 12. . .	17.7		Cu, 84; Mn, 12; Ni, 4 . . . . .	287	.000
Copper, 65.8; zinc, 34.2. .	37.8	.158	Cu, 80.5; Mn, 3; Ni, 16.5 . . .	294	.000
Copper, 90; lead, 10 . . . .	31.7		Cu, 79.5; Mn, 19.7; Fe, 0.8 . .	393	.000
Copper, 97; aluminum, 3. . .	53.0	.090	Mercury . . . . .	566	.072
Cu, 87; Ni, 6.5; Al, 6.5. . .	89.5	.065	Nickel . . . . .	73.7	.62
Copper, 65; nickel, 25 . . .	205	.019	Palladium, pure . . . . .	61.1	.354
Cu, 70; manganese, 30 . . .	605	.004	Platinum, annealed . . . . .	539	.247
German silver			Platinum, 67; silver, 33 . . .	145	.133
Cu, 60; Zn, 25; Ni, 15 . . .	180	.036	Phosphor bronze . . . . .	33.6	.394
Gold, 99.9% pure. ....	13.2	.377	Silver, pure. ....	8.82	.400
Gold, 67; silver, 33. ....	61.8	.065	Tin, pure. ....	78.5	.440
Iron, very pure. ....	54.5	.625	Zinc, pure. ....	34.5	.406

(D) Dewar and Fleming; (M) Matthiessen.

**Conductivity of Aluminum.** — J. W. Richards (*Jour. Frank. Inst.*, Mar., 1897) gives for hard-drawn aluminum of purity 98.5, 99.0, 99.5, and 99.75% respectively a conductivity of 55, 59, 61, and 63 to 64%, copper being 100%. The Pittsburg Reduction Co. claims that its purest aluminum has a conductivity of over 64.5%. (*Eng'g News*, Dec. 17, 1896.)

**German Silver.** — The resistance of German silver depends on its composition. Matthiessen gives it as nearly 13 times that of copper, with a temperature coefficient of 0.0004433 per degree C. Weston, how-

ever (*Proc. Electrical Congress*, 1893, p. 179), has found copper-nickel-zinc alloys (German silver) which had a resistance of nearly 28 times that of copper, and a temperature coefficient of about one-half that given by Matthiessen.

**Conductors and Insulators in Order of Their Value.**

<p>CONDUCTORS.</p> <p>All metals Well-burned charcoal Plumbago Acid solutions Saline solutions Metallic ores Animal fluids Living vegetable substances Moist earth Water</p>	<p>INSULATORS (NON-CONDUCTORS).</p> <p>Dry air Shellac Paraffin Amber Resins Sulphur Wax Jet Glass Mica</p>	<p>Ebonite Gutta-percha India-rubber Silk Dry paper Parchment Dry leather Porcelain Oils</p>
--	---	--

According to Culley, the resistance of distilled water is 6754 million times as great as that of copper. Impurities in water decrease its resistance.

**Resistance Varies with Temperature.**—For every degree Centigrade the resistance of copper increases about 0.4%, or for every degree F., 0.2222%. Thus a piece of copper wire having a resistance of 10 ohms at 32° would have a resistance of 11.11 ohms at 82° F.

The following table shows the amount of resistance of a few substances used for various electrical purposes by which 1 ohm is increased by a rise of temperature of 1° C.

<p>Platinoid . . . . . 0.00021 Platinum silver . . . . . 0.00031 German silver (see above) . . 0.00044</p>	<p>Gold, silver . . . . . 0.00065 Cast iron . . . . . 0.00080 Copper . . . . . 0.00400</p>
--	--

**Annealing.**—Resistance is lessened by annealing. Matthiessen gives the following relative conductivities for copper and silver, the comparison being made with pure silver at 100° C.:

Metal.	Temp. C.	Hard.	Annealed.	Ratio.
Copper . . . . .	11°	95.31	97.83	1 to 1.027
Silver . . . . .	14.6°	95.36	103.33	1 to 1.084

Dr. Siemens compared the conductivities of copper, silver, and brass with the following results. Ratio of hard to annealed:

Copper . . . . 1 to 1.058    Silver . . . . 1 to 1.145    Brass . . . . 1 to 1.180

**STANDARD VALUES FOR RESISTIVITY AND TEMPERATURE COEFFICIENT OF COPPER.**

Bureau of Standards, 1914.

The Bureau of Standards made measurements of a large number of representative samples of copper and established standard values of resistivity and temperature coefficients, which have been adopted by the International Electrochemical Commission.

**Conductivity of Copper.**

The following rules of the International Electrical Commission have been adopted by the American Institute of Electrical Engineers.

The following shall be taken as normal values for standard annealed copper:

(1) At a temperature of 20° C. the resistance of a wire of standard annealed copper one meter in length and of a uniform section of 1 square millimeter is 1/58 ohm = 0.017241 . . . ohm.

(2) At a temperature of 20° C. the density of standard annealed copper is 8.89 grams per cubic centimeter.

(3) At a temperature of 20° C. the "constant mass" temperature coefficient of resistance of standard annealed copper, measured between two potential points rigidly fixed to the wire, is 0.00393 = 1/254.45 . . . per degree centigrade.



(4) As a consequence it follows from (1) and (2) that, at a temperature of 20° C. the resistance of a wire of standard annealed copper of uniform section, one meter in length and weighing one gram, is  $(1/58) \times 8.89 = 0.15328 \dots \dots \text{ohm}$ .

Paragraphs (1) and (4) define what are sometimes called "volume resistivity" and "mass resistivity" respectively. This may be expressed in other units as follows: Volume resistivity = 1.7241 microhm-cm. (or microhms in a cm. cube) at 20° C. = 0.67879 microhm inch at 20° C. and mass resistivity = 875.20 ohms (mile, pound) at 20° C.

The new value is known as the International Annealed Copper Standard, and is equivalent to

0.017241 ohm (meter, mm<sup>2</sup>) at 20° C.

The units of mass resistivity and volume resistivity are interrelated through the density; this was taken as 8.89 grams per cm<sup>3</sup> at 20° C. by the International Electrochemical Commission. The International Annealed Copper Standard, in various units of mass resistivity and volume resistivity, is:

0.15328	ohm (meter, gram) at 20° C.
875.20	ohms (mile, pound) at 20° C.
0.017241	ohm (meter, mm <sup>2</sup> ) at 20° C.
1.7241	microhm-cm. at 20° C.
0.67879	microhm-inch at 20° C.
10.371	ohms (mil, foot) at 20° C.

*The Temperature Coefficient of Resistance of Copper.*—The Bureau of Standards' investigation of the temperature coefficient showed that the coefficient varies with different samples, but that the relation of conductivity to temperature coefficient is substantially a simple proportionality.

The general law may be expressed by the following practical rule: The 20° C. temperature coefficient of a sample of copper is the product of the per cent. conductivity by 0.00393. There are sometimes cases when the temperature coefficient is more easily measured than the conductivity, and the conductivity can be computed from the relation: per cent. conductivity = 254.5  $\times$  temperature coefficient.

When a temperature coefficient of resistance must be assumed the best value to assume for good commercial annealed copper wire is that corresponding to 100 per cent. conductivity, viz.:

$$\alpha_0 = 0.00427, \quad \alpha_{15} = 0.00401, \quad \alpha_{20} = 0.00393, \quad \alpha_{25} = 0.00385$$

$$\left( \alpha_{20} = \frac{Rt - R_{20}}{R_{20} (t - 20)}, \text{ etc.} \right)$$

This value was adopted as standard by the International Electrochemical Commission in 1913. It would usually apply to instruments and machines, since they are generally wound with annealed wire. Experiment has shown that distortions such as those caused by winding and ordinary handling do not affect the temperature coefficient.

Similarly, when assumption is unavoidable, the temperature coefficient of good commercial hard-drawn copper wire may be taken as that corresponding to a conductivity of 97.3 per cent., viz.:

$$\alpha_0 = 0.00414, \quad \alpha_{15} = 0.00390, \quad \alpha_{20} = 0.00382, \quad \alpha_{25} = 0.00375$$

Rule for reducing resistivity from one temperature to another: The change of resistivity of copper per degree C. is a constant, independent of the temperature of reference and of the sample of copper. This "resistivity-temperature constant" may be taken, for general purposes, as 0.00060 ohm (meter, gram), or 0.0068 microhm-cm. More exactly, it is:

0.000.597	ohm (meter, gram)
or, 0.000.0681	ohm (meter, mm <sup>2</sup> )
or, 0.006.81	microhm-cm.
or, 3.41	ohms (mile, pound)
or, 0.002.68	microhm-inch,
or, 0.040.9	ohm (mil, foot).

*Continued on p. 1406.*

## COMPLETE WIRE TABLE, STANDARD ANNEALED COPPER.

American Wire Gage (B. & S.). English Units  
(Bureau of Standards, 1914)

Gage No.	Diam. in Mills at 20° C.	Cross-Section at 20° C.		Pounds per 1000 Feet.	Feet per Pound.	Ohms per 1000 Feet.					
		Circular Mills.	Square Inches.			0° C.	15° C.	20° C.	25° C.	50° C.	75° C.
						32° F.	59° F.	68° F.	77° F.	122° F.	167° F.
0000	460.0	211 600.	0.1662	640.5	1.561	0.04516	0.04805	0.04901	0.04998	0.05479	0.05961
000	409.6	167 800.	.1318	507.9	1.968	.05695	.06059	.06180	.06302	.06909	.07516
00	364.8	133 100.	.1045	402.8	2.482	.07181	.07640	.07793	.07947	.08712	.09478
0	324.9	105 500.	.08289	319.5	3.130	.09055	.09634	.09827	1.002	1.099	1.195
1	289.3	83 690.	.06573	253.3	3.947	.1142	.1215	.1239	.1264	.1385	.1507
2	257.6	66 370.	.05213	200.9	4.977	.1440	.1532	.1563	.1593	.1747	.1900.
3	229.4	52 640.	.04134	159.3	6.276	.1816	.1932	.1970	.2009	.2203	.2396
4	204.3	41 740.	.03278	126.4	7.914	.2289	.2436	.2485	.2533	.2778	.3022
5	181.9	33 100.	.02600	100.2	9.980	.2887	.3072	.3133	.3195	.3502	.3810
6	162.0	26 250.	.02062	79.46	12.58	.3640	.3873	.3951	.4028	.4416	.4805
7	144.3	20 820.	.01635	63.02	15.87	.4590	.4884	.4982	.5080	.5569	.6059
8	128.5	16 510.	.01297	49.98	20.01	.5788	.6158	.6282	.6405	.7023	.7640
9	114.4	13 090.	.01028	39.63	25.23	.7299	.7766	.7921	.8077	.8855	.9633
10	101.9	10 380.	.008155	31.43	31.82	.9203	.9792	.9989	1.018	1.117	1.215
11	90.74	8 234.	.006467	24.92	40.12	1.161	1.235	1.260	1.284	1.408	1.532
12	80.81	6 530.	.005129	19.77	50.59	1.463	1.557	1.588	1.619	1.775	1.931
13	71.96	5 178.	.004067	15.68	63.80	1.845	1.963	2.003	2.042	2.239	2.436
14	64.08	4 107.	.003225	12.43	80.44	2.327	2.476	2.525	2.575	2.823	3.071
15	57.07	3 257.	.002558	9.858	101.4	2.934	3.122	3.184	3.247	3.560	3.873
16	50.82	2 583.	.002028	7.818	127.9	3.700	3.937	4.016	4.094	4.489	4.884
17	45.26	2 048.	.001609	6.200	161.3	4.666	4.964	5.064	5.163	5.660	6.158

COMPLETE WIRE TABLE, STANDARD ANNEALED COPPER.—Continued.

Gage No.	Cross-Section at 20° C.		Ohms per 1000 Feet.							Feet per Pound.
	Diam. in Mills at 20° C.	Circular Mills.	Square Inches.	0° C.	15° C.	20° C.	25° C.	50° C.	75° C.	
				32° F.	59° F.	68° F.	77° F.	122° F.	167° F.	
18	40.30	1624.	.001276	5.883	6.260	6.385	6.510	7.138	7.765	
19	35.89	1288.	.001012	7.418	7.893	8.051	8.210	9.001	9.792	
20	31.96	1022.	.0008023	9.355	9.953	10.15	10.35	11.35	12.35	
21	28.46	810.1	.0006363	11.80	12.55	12.80	13.05	14.31	15.57	
22	25.35	642.4	.0005046	14.87	15.83	16.14	16.46	18.05	19.63	
23	22.57	509.5	.0004002	18.76	19.96	20.36	20.76	22.76	24.76	
24	20.10	404.0	.0003173	23.65	25.16	25.67	26.17	28.70	31.22	
25	17.90	320.4	.0002517	29.82	31.73	32.37	33.00	36.18	39.36	
26	15.94	254.1	.0001996	37.61	40.01	40.81	41.62	45.63	49.64	
27	14.20	201.5	.0001583	47.42	50.45	51.47	52.48	57.53	62.59	
28	12.64	159.8	.0001255	59.80	63.62	64.90	66.17	72.55	78.93	
29	11.26	126.7	.00009953	75.40	80.23	81.83	83.44	91.48	99.52	
30	10.03	100.5	.00007894	95.08	101.2	103.2	105.2	115.4	125.5	
31	8.928	79.70	.00006260	119.9	127.6	130.1	132.7	145.5	158.2	
32	7.950	63.21	.00004964	151.2	160.9	164.1	167.3	183.4	199.5	
33	7.080	50.13	.00003937	190.6	202.8	206.9	211.0	231.3	251.6	
34	6.305	39.75	.00003122	240.4	255.8	260.9	266.0	291.7	317.3	
35	5.615	31.52	.00002476	303.1	322.5	329.0	335.5	367.8	400.1	
36	5.000	25.00	.00001964	382.2	406.7	414.8	423.0	463.7	504.5	
37	4.453	19.83	.00001557	482.0	512.8	523.1	533.4	584.8	636.2	
38	3.965	15.72	.00001235	607.8	646.7	659.6	672.6	737.4	802.2	
39	3.531	12.47	.000009793	766.4	815.4	831.8	848.1	929.8	1012.	
40	3.145	9.888	.00000766	966.5	1028.	1049.	1069.	1173.	1276.	



*Resistivity of Hard-Drawn Copper Wires.*—In general the resistivity of hard-drawn wires varies with the size of the wire, while the resistivity of annealed wires does not. The difference between the resistivity of annealed and hard-drawn wires increases as the diameter of the wire decreases. This general conclusion is, however, complicated in any particular case by the number of drawings between annealings, amount of reduction to each drawing, etc. For No. 12 A.W.G. (B. & S.), the conductivity of hard-drawn wires was found to be less than the conductivity of annealed wires by 2.7 per cent.

*Density of Copper.*—The international standard density for copper, at 20° C., is 8.89 grams per cubic centimeter. This is the value which has been used by the A.I.E.E., and most other authorities in the past. Recent measurements have indicated this value as a mean. This density, 8.89, at 20° C., corresponds to a density of 8.90 at 0° C. In English units, the density at 20° C. = 0.32117 pounds per cubic inch. For a complete treatise on this subject, see Bulletin No. 31, Bureau of Standards.

**Approximate Rules for the Resistance of Copper Wire.**—The resistance of any copper wire at 20° C. or 68° F., according to Matthiessen's standard, is  $R = \frac{10.35l}{d^2}$ , in which  $R$  is the resistance in international ohms,  $l$  the length of the wire in feet, and  $d$  its diameter in mils. (1 mil =  $\frac{1}{1000}$  inch.)

A No. 10 wire, A.W.G., 0.1019 in. diam (practically 0.1 in.), 1000 ft. in length, has a resistance of 1 ohm at 68° F. and weighs 31.4 lbs.

If a wire of a given length and size by the American or Brown & Sharpe gauge has a certain resistance, a wire of the same length and three numbers higher has twice the resistance, six numbers higher four times the resistance, etc.

Wire gauge, A.W.G. No. . . . .	000	1	4	7	10	13	16	19	22
Relative resistance . . . . .	16	8	4	2	1	1/2	1/4	1/8	1/16
“ section or weight . . . . .	1/16	1/8	1/4	1/2	1	2	4	8	16

## DIRECT ELECTRIC CURRENTS.

**Ohm's Law.**—This law expresses the relation between the three fundamental units of resistance, electrical pressure, and current. It is:

$$\text{Current} = \frac{\text{electrical pressure}}{\text{resistance}}; I = \frac{E}{R}; \text{whence } E = IR, \text{ and } R = \frac{E}{I}.$$

In terms of the units of the three quantities,

$$\text{Amperes} = \frac{\text{volts}}{\text{ohms}}; \text{volts} = \text{amperes} \times \text{ohms}; \text{ohms} = \frac{\text{volts}}{\text{amperes}}.$$

**EXAMPLES: Simple Circuits.** — 1. If the source has an effective electrical pressure of 100 volts, and the resistance is two ohms, what is the current?

$$I = \frac{E}{R} = \frac{100}{2} = 50 \text{ amperes.}$$

2. What pressure will give a current of 50 amperes through a resistance of 2 ohms?  $E = IR = 50 \times 2 = 100$  volts.

3. What resistance is required to obtain a current of 50 amperes when the pressure is 100 volts?  $R = E \div I = 100 \div 50 = 2$  ohms.

Ohm's law applies equally to a complete electrical circuit and to any part thereof.

**Series Circuits.** — If conductors are arranged one after the other they are said to be in series, and the total resistance of the circuit is the sum of the resistances of its several parts. Let  $A$ , Fig. 226, be a source of current, such as a battery or generator, producing a difference of potential or

E.M.F. of 120 volts, measured across *ab*, and let the circuit contain four conductors whose resistances,  $r_1, r_2, r_3, r_4$ , are 1 ohm each, and three other resistances,  $R_1, R_2, R_3$ , each 2 ohms. The total resistance is 10 ohms, and by Ohm's law the current  $I = E \div R = 120 \div 10 = 12$  amperes. This current is constant throughout the circuit, and a series circuit is therefore one of *constant current*. The drop of potential in the whole circuit from *a* around to *b* is 120 volts, or  $E = RI$ . The drop in any portion depends on the resistance of that portion; thus from *a* to

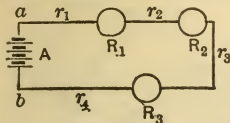

FIG. 226.

$R_1$  the resistance is 1 ohm, the constant current 12 amperes, and the drop  $1 \times 12 = 12$  volts. The drop in passing through each of the resistance  $R_1, R_2, R_3$  is  $2 \times 12 = 24$  volts.

**Parallel, Divided, or Multiple Circuits.**— Let *B*, Fig. 227, be a generator producing an E.M.F. of 220 volts across the terminals *ab*.

The current is divided, so that part flows through the main wires *ac* and part through the "shunt" *s*, having a resistance of 0.5 ohm. Also the current has three paths between *c* and *d*, viz., through the three resistances in parallel  $R_1, R_2, R_3$ , of 2 ohms each. Consider that the resistance of the wires is so small that it may be neglected. Let the conductances of the four paths be represented by  $C_s, C_1, C_2, C_3$ . The total conductance is  $C_s + C_1 + C_2 + C_3 = C$  and the total resistance  $R = 1 \div C$ . The conductance of each path is the reciprocal of its resistance, the total conductance is the sum of the separate conductances, and the resistance of the combined or "parallel" paths is the reciprocal of the total conductance.

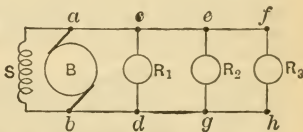

FIG. 227.

$$R = 1 \div \left( \frac{1}{0.5} + \frac{1}{2} + \frac{1}{2} + \frac{1}{2} \right) = 1 \div 3.5 = 0.286 \text{ ohm.}$$

The current  $I = E \div R = 770$  amperes.

**Conductors in Series and Parallel.**— Let the resistances in parallel be the same as in Fig. 227, with the additional resistance of 0.1 ohm in each of the six sections of the main wires, *ac, bd*, etc., in series. The voltage across *ab* being 220 volts, determine the drop in voltage at the several points, the total current, and the current through each path. The problem is somewhat complicated. It may be solved as follows: Consider first the points *eg*; here there are two paths for the current, *efgh* and *eg*. Find the resistance and the conductance of each and the total resistance (the reciprocal of the joint conductance) of the parallel paths. Next consider the points *cd*; here there are two paths — one through *e* and the other through *cd*. Find the total resistance as before. Finally consider the points *ab*; here there are two paths — one through *c*, the other through *s*. Find the conductances of each and their sum. The product of this sum and the voltage at *ab* will be the total amperes of current, and the current through any path will be proportional to the conductance of that path. The resistances, *R*, and conductances, *C*, of the several paths are as follows:

	<i>R</i>	<i>C</i>
$R_a$ of <i>efR<sub>3</sub>hg</i> = 0.1 + 2 + 0.1 = 2.2	2.2	0.4545
$R_b$ of <i>eR<sub>2</sub>g</i> = 2	= 2	0.5
Joint $R_c$ = 1.048		0.9545
$R_d$ of <i>ce + dg + R<sub>c</sub></i> = 1.248	= 1.248	0.8013
$R_e$ of <i>cR<sub>1</sub>d</i> = 2	= 2	0.5
Joint $R_f$ = 0.7687		1.3013

$R_g$ of $ac + bd + R_f$	= 0.9687	1.0332
$R_h$ of $s$	= 0.5	2
		3.0332
Joint $R_a + R_h = 0.330$		

Total current =  $220 \times 3.0332 = 667.3$  amperes.  
 Current through  $s = 220 \times 2 = 440$  amp.; through  $c = 227.3$  amp.  
 " "  $cR_1d = 227.3 \times 0.5 \div 1.3013 = 87.34$  amp.  
 " "  $e = 227.3 \times 0.8013 \div 1.3013 = 139.96$  " "  
 " "  $eR_2g = 139.96 \times 0.5 \div 0.9545 = 73.31$  " "  
 " "  $fR_3 = 139.96 \times 0.4545 \div 0.9545 = 66.65$  " "

The drop in voltage in any section of the line is found by the formula  $E = RI$ ,  $R$  being the resistance of that section and  $I$  the current in it. As the  $R$  of each section is 0.1 ohm we find  $E$  for  $ac$  and  $bd$  each = 22.7 volts, for  $ce$  and  $dg$  each 14.0 volts, and for  $ef$  and  $gh$  each 6.67 volts. The voltage across  $cd$  is  $220 - 2 \times 22.7 = 174.6$  volts; across  $eg$ ,  $174.6 - 2 \times 14.0 = 146.6$ , and across  $fh$   $146.6 - 2 \times 6.67 = 133.3$  volts. Taking these voltages and the resistances  $R_1, R_2, R_3$ , each 2 ohms, we find from  $I = E \div R$  the current through each of these resistances 87.3, 73.3, and 66.65 amperes as before.

**Internal Resistance.** — In a simple circuit we have two resistances, that of the circuit  $R$  and that of the internal parts of the source of electro-motive force, called internal resistance,  $r$ . The formula of Ohm's law when the internal resistance is considered is  $I = E \div (R + r)$ .

**Power of the Circuit.** — The power, or rate of work, in watts = current in amperes  $\times$  electro-motive force in volts =  $I \times E$ . Since  $I = E \div R$ , watts =  $E^2 \div R = \text{electro-motive force}^2 \div \text{resistance}$ .

**EXAMPLE.** — What H.P. is required to supply 100 lamps of 40 ohms resistance each, requiring an electro-motive force of 60 volts?

The number of volt-amperes for each lamp is  $\frac{E^2}{R} = \frac{60^2}{40}$ , 1 volt-ampere = 0.00134 H.P.; therefore  $\frac{60^2}{40} \times 100 \times 0.00134 = 12$  H.P. (electrical) very nearly.

**Electrical, Brake, and Indicated Horse-power.** — The power given by a dynamo = volts  $\times$  amperes  $\div$  1000 = kilowatts, kw. Volts  $\times$  out amperes  $\div$  746 = electrical horse-power, E.H.P. The power put into a dynamo shaft by a direct-connected engine or other prime mover is called the shaft or brake horse-power, B.H.P. If  $e_1$  is the efficiency of the dynamo, B.H.P. = E.H.P.  $\div e_1$ . If  $e_2$  is the mechanical efficiency of the engine, the indicated horse-power, I.H.P. = brake H.P.  $\div e_2 = \text{E.H.P.} \div (e_1 \times e_2)$ .

If  $e_1$  and  $e_2$  each = 91.5%, I.H.P. = E.H.P.  $\times$  1.194 = kw.  $\times$  1.60. In direct-connected units of 250 kw. or less the rated H.P. of the engine is commonly taken as 1.6  $\times$  the rated kw. of the generator.

Electric motors are rated at the H.P. given out at the pulley or belt. H.P. of motor = E.H.P. supplied  $\times$  efficiency of motor.

**Heat Generated by a Current.** — Joule's law shows that the heat developed in a conductor is directly proportional, 1st, to its resistance; 2d, to the square of the current strength; and 3d, to the time during which the current flows, or  $H = I^2Rt$ . Since  $I = E \div R$ ,

$$I^2Rt = \frac{E}{R} IRt = EIt = E \frac{E}{R} t = \frac{E^2t}{R}.$$

Or, heat = current<sup>2</sup>  $\times$  resistance  $\times$  time  
 = electro-motive force  $\times$  current  $\times$  time.  
 = electro-motive force<sup>2</sup>  $\times$  time  $\div$  resistance.

$Q$  = quantity of electricity flowing =  $It = (Et \div R)$ .  
 $H = EQ$ ; or heat = electro-motive force  $\times$  quantity.

The electro-motive force here is that causing the flow, or the difference in potential between the ends of the conductor.

The electrical unit of heat, or "joule" =  $10^7$  ergs = heat generated in one second by a current of 1 ampere flowing through a resistance of one



ohm = 0.239 gramme of water raised 1° C.  $H = I^2Rt \times 0.239$  gramme calories =  $I^2Rt \times 0.0009478$  British thermal units.

In electric lighting the energy of the current is converted into heat in the lamps. The resistance of the lamp is made great so that the required quantity of heat may be developed, while in the wire leading to and from the lamp the resistance is made as small as is commercially practicable, so that as little energy as possible may be wasted in heating the wire.

**Heating of Conductors.** (From Kapp's Electrical Transmission of Energy.) — It becomes a matter of great importance to determine beforehand what rise in temperature is to be expected in each given case, and if that rise should be found to be greater than appears safe, provision must be made to increase the rate at which heat is carried off. This can generally be done by increasing the superficial area of the conductor. Say we have one circular conductor of 1 square inch area, and find that with 1000 amperes flowing it would become too hot. Now by splitting up this conductor into 10 separate wires each one-tenth of a square inch cross-sectional area, we have not altered the total amount of energy transformed into heat, but we have increased the surface exposed to the cooling action of the surrounding air in the ratio of 1:  $\sqrt{10}$ , and therefore the ten thin wires can dissipate more than three times the heat, as compared with the single thick wire.

Prof. Forbes states that an insulated wire carries a greater current without overheating than a bare wire if the diameter be not too great. Assuming the diameter of the cable to be twice the diam. of the conductor, a greater current can be carried in insulated wires than in bare wires up to 1.9 inch diam. of conductor. If diam. of cable = 4 times diam. of conductor, this is the case up to 1.1 inch diam. of conductor.

**Heating of Bare Wires.** — The following formulæ are given by Kennelly:

$$T = \frac{I^2}{d^3} \times 90,000 + t; \quad d = 44.8 \sqrt[3]{\frac{I^2}{T - t}}$$

$T$  = temperature of the wire and  $t$  that of the air, in Fahrenheit degrees;  $I$  = current in amperes,  $d$  = diameter of the wire in mils.

If we take  $T - t = 90^\circ F.$ ,  $\sqrt[3]{90} = 4.48$ , then

$$d = 10 \sqrt[3]{I^2} \quad \text{and} \quad I = \sqrt{d^3 + 1000}$$

This latter formula gives for the carrying capacity in amperes of bare wires almost exactly the figures given for weather-proof wires in the Fire Underwriters' table, except in the case of Nos. 18 and 16, B. & S. gauge, for which the formula gives 8 and 11 amperes, respectively, instead of 5 and 8 amperes, given in the table.

**Heating of Coils.** — The rise of temperature in magnet coils due to the passage of current through the wire is approximately proportional to the watts lost in the coil per unit of effective radiating surface, thus:

$$t \propto \frac{I^2R}{S} \quad \text{or} \quad t = \frac{I^2R}{kS}$$

$t$  being the temperature rise in degrees Fahr.;  $S$ , the effective radiating surface; and  $k$  a coefficient which varies widely, according to condition. In electromagnet coils of small size and power,  $k$  may be as large as 0.015. Ordinarily it ranges from 0.012 down to 0.005; a fair average is 0.007. The more exposed the coil is to air circulation, the larger is the value of  $k$ ; the larger the proportion of iron to copper, by weight, in the core and winding, the thinner the winding with relation to its dimension parallel with the magnet core, and the larger the "space factor" of the winding, the larger will be the value of  $k$ . The space factor is the ratio of the actual copper cross-section of the whole coil to the gross cross-section of copper, insulation, and interstices.

**Fusion of Wires.** — W. H. Preece gives a formula for the current required to fuse wires of different metals, viz.,  $I = ad^{3/2}$  in which  $d$  is the diameter in inches and  $a$  a coefficient whose value for different metals is as follows: Copper, 10,244; aluminum, 7585; platinum, 5172; German silver, 5230; platinoid, 4750; iron, 3148; tin, 1462; lead, 1379; alloy of 2 lead and 1 tin, 1318.

**Allowable Carrying Capacity of Copper Wires.**

(For inside wiring, National Board of Fire Underwriters' Rules.)

B. & S. Gauge.	Circular Mils.	Amperes.		Circular Mils.	Amperes.	
		Rubber Covered.	Other Insulation.		Rubber Covered.	Other Insulation.
18	1,624	3	5	200,000	200	300
16	2,583	6	8	300,000	270	400
14	4,107	12	16	400,000	330	500
12	6,530	17	23	500,000	390	590
10	10,380	24	32	600,000	450	680
8	16,510	33	46	700,000	500	760
6	26,250	46	65	800,000	550	840
5	33,100	54	77	900,000	600	920
4	41,740	65	92	1,000,000	650	1,000
3	52,630	76	110	1,100,000	690	1,080
2	66,370	90	131	1,200,000	730	1,150
1	83,690	107	156	1,300,000	770	1,220
0	105,500	127	185	1,400,000	810	1,290
00	133,100	150	220	1,600,000	890	1,430
000	167,800	177	262	1,800,000	970	1,550
0000	211,600	210	312	2,000,000	1,050	1,670

Wires smaller than No. 14 B. & S. gauge must not be used except in fixtures and pendant cords.

The lower limit is specified for rubber-covered wires to prevent deterioration of the insulation by the heat of the wires.

For insulated aluminum wire the safe-carrying capacity is 84 per cent of that of copper wire with the same insulation.

See pamphlets published by the National Board of Fire Underwriters, New York, for complete specifications and rules for wiring.

**Underwriters' Insulation.** — The thickness of insulation required by the rules of the National Board of Fire Underwriters varies with the size of the wire, the character of the insulation, and the voltage. The thickness of insulation on rubber-covered wires carrying voltages up to 600 varies from 1/32 inch for a No. 18 B. & S. gauge wire to 1/8 inch for a wire of 1,000,000 circular mils. Weather-proof insulation is required to be slightly thicker. For voltages of over 600 the insulation varies from 1/16 inch for No. 14 B. & S. gage to 9/64 inch for 1,000,000 C. M. and over.

**ELECTRIC TRANSMISSION, DIRECT CURRENTS.**

**Cross-section of Wire Required for a Given Current.—**

Let  $R$  = resistance of a given line of copper wire, in ohms;

$r$  = " " " 1 mil-foot of copper;

$L$  = length of wire, in feet;

$e$  = drop in voltage between the two ends;

$I$  = current, in amperes;

$A$  = sectional area of wire, in circular mils;

then  $I = \frac{e}{R}$ ;  $R = \frac{e}{I}$ ;  $R = r \frac{L}{A}$ ; whence  $A = \frac{rIL}{e}$ .

The value of  $r$  for soft copper wire at 68° F. is 10.371 international ohms. For ordinary drawn copper wire the value of 10.8 is commonly taken, corresponding to a conductivity of 97.2 per cent.

For a circuit, going and return, the total length is  $2L$ , and the formula becomes  $A = 21.6IL \div e$ ,  $L$  here being the distance from the point of supply to the point of delivery.

If  $E$  is the voltage at the generator and  $a$  the per cent of drop in the line, then  $e = Ea \div 100$ , and  $A = 2160 IL \div aE$ .

If  $P$  = the power in watts, =  $EI$ , then  $I = \frac{P}{E}$ , and  $A = \frac{2160 PL}{aE^2}$ .

If  $P_k$  = the power in kilowatts,  $A = 2,160,000 P_k L \div aE^2$ .

If  $L_m$  = the distance in miles and  $A_c$  the area in circular inches, then

$A_c = 6405 P_k L_m \div aE^2$ . If  $A_s =$  area in square inches,  $A_s = 5030 P_k L_m \div aE^2$ . When the area in circular mils has been determined by either of these formulæ reference should be made to the table of Allowable Capacity of Wires, to see if the calculated size is sufficient to avoid overheating. For all interior wiring the rules of the National Board of Fire Underwriters should be followed.

**Weight of Copper for a Given Power.** — Taking the weight of a mil-foot of copper at 0.000003027 lb., the weight of copper in a circuit of length  $2L$  and cross-section  $A$ , in circ. mils, is 0.000006054  $LA$  lbs., =  $W$ . Substituting for  $A$  its value  $2160PL \div aE^2$  we have

$$W = 0.0130766 PL^2 \div aE^2; \quad P \text{ in watts, } L \text{ in ft.}$$

$$W = 13.0766 P_k L^2 \div aE^2; \quad P_k \text{ in kilowatts, } L \text{ in ft.}$$

$$W = 364,556,000 P_k L_m^2 \div aE^2; \quad P_k \text{ in kilowatts, } L_m \text{ in miles.}$$

The weight of copper required varies directly as the power transmitted; inversely as the percentage of drop or loss; directly as the square of the distance; and inversely as the square of the voltage.

From the last formula the following table has been calculated:

WEIGHT OF COPPER WIRE TO CARRY 1000 KILOWATTS WITH 10% LOSS.

Distance in Miles.	Weight in Lbs.					
	1	5	10	20	50	100
Volts.						
500	145,822	3,645,560	.....	.....	.....	.....
1,000	36,456	911,390	3,645,560	.....	.....	.....
2,000	9,114	227,848	911,390	3,645,560	.....	.....
5,000	1,458	36,456	145,822	593,290	3,645,560	.....
10,000	365	9,114	36,456	145,822	911,390	3,645,560
20,000	91	2,278	9,114	36,456	227,848	911,390
40,000	.....	570	2,278	9,114	56,962	227,848
60,000	.....	.....	1,013	4,051	25,316	101,266

In calculating the distance, an addition of about 5 per cent should be made for sag of the wires.

**Short-circuiting.** — From the law  $I = E/R$  it is seen that with any pressure  $E$ , the current  $I$  will become very great if  $R$  is made very small. In short-circuiting the resistance becomes small and the current therefore great. Hence the dangers of short-circuiting a current.

### ECONOMY OF ELECTRIC TRANSMISSION.

The loss of power in a transmission line is ordinarily given in per cent of the total power consumed in the conductors at maximum load. Whatever the line pressure may be, the size of the conductors varies inversely with the percentage of loss. Consequently the maximum line loss which can be allowed is dependent on the most economical size of the line conductors.

In 1881 Lord Kelvin gave out a statement in regard to the most economical size of conductors. This statement, which is known as "Kelvin's law," was as follows:

"The most economical area of conductor will be that for which the annual interest on the capital outlay equals the annual cost of energy wasted."

According to this rule, the cheaper the cost of power, the less should be the capital outlay for the conductors, thus allowing a smaller size to be used. George Forbes states that the most economical section of the conductor is independent of the voltage and the distance, and is proportional to the current.

It is generally assumed that the cost of the pole line and the insulators is constant and not affected by the variation in the size of the line conductors.

If  $A$  = interest cost per year of conductors erected, in dollars,  
 $B$  = value of the line loss per year, in dollars; then for the most economical cross-section of the conductors

$$A = B.$$



- If  $K$  = Cost per kilowatt-year of lost power, in dollars,
- $K_1$  = Cost per pound of wires erected, in dollars,
- $L$  = Length of line in 1000 ft.,
- $D^2$  = Cross-section of conductor in circular mils,
- $I$  = Line current in amperes,
- $p$  = per cent interest,

then  $A = \frac{p}{100} \times K_1 \times 0.003 \times L \times D^2$ ,

$B = K \times I^2 \times 10.5 \times \frac{L}{D^2}$

$\frac{p}{100} \times K_1 \times 0.003 \times L \times D^2 = K \times I^2 \times 10.5 \times \frac{L}{D^2}$

$D^2 = 592 I \sqrt{\frac{K}{p K_1}}$

$D^2$  is the cross-section, in circular mils, that will give the most economical line loss.

In the following, the above equation is worked out for three different rates of interest:

For 4%,  $D^2 = 296 I \sqrt{\frac{K}{K_1}}$ ; For 5%,  $D^2 = 265 I \sqrt{\frac{K}{K_1}}$ ;

For 6%,  $D^2 = 242 I \sqrt{\frac{K}{K_1}}$

In determining the value of  $I$ , care must be taken that the annual mean value of the current is used. The value of  $K$  must also be the one for which the power, representing the line loss, can be produced, and not that for which it can be sold.

**Wire Tables.** — The tables on the following page show the relation between load, distance, and "drop" or loss by voltage in a two-wire direct-current circuit of any standard size of wire. The tables are based on the formula

$(21.6 IL) \div A = \text{Drop in volts.}$

$I$  = current in amperes,  $L$  = distance in feet from point of supply to point of delivery,  $A$  = sectional area of wire in circular mils. The factors  $I$  and  $L$  are combined in the table, in the compound factor "ampere feet."

**EXAMPLES IN THE USE OF THE WIRE TABLES.** — 1. Required the maximum load in amperes at 220 volts that can be carried 95 feet by No. 6 wire without exceeding 1½% drop.

Find No. 6 in the 220-volt column of Table I; opposite this in the 1½% column is the number 4005, which is the ampere-feet. Dividing this by the required distance (95 feet) gives the load, 42.15 amperes.

*Example 2.* A 500-volt line is to carry 100 amperes 600 feet with a drop not exceeding 5%; what size of wire will be required?

The ampere-feet will be  $100 \times 600 = 60,000$ . Referring to the 5% column of Table II, the nearest number of ampere-feet is 60,750, which is opposite No. 3 wire in the 500-volt column.

These tables also show the percentage of the power delivered to a line that is lost in non-inductive alternating-current circuits. Such circuits are obtained when the load consists of incandescent lamps and the circuit wires lie only an inch or two apart, as in conduit wiring.

**Efficiency of Electric Systems.**—The efficiency of a system is the ratio of the power delivered by the electric motors at the distant end of the line to the power delivered to the dynamo-electric machines at the other end. The efficiency of a generator or motor varies with its load and with the size of the machine, ranging about as follows:

Average Full-load Efficiency of Generators:

K.W. ....	25	50	100	200	500	1000	2000	3000
Eff. % .....	88	90	91	92	93	94	94.5	95

Average Full-load Efficiency of Motors:

H.P. ....	1	2	5	10	25	50	100	200	500
Eff. % ....	80	82	85	87	88	90	91	92	93

The efficiency of both generators and motors decreases, at first very

WIRE TABLE — RELATION BETWEEN LOAD, DISTANCE, LOSS, AND SIZE OF CONDUCTOR.

NOTE. — The numbers in the body of the tables are Ampere-Feet, i.e., Amperes × Distance (length of one wire). See examples below.

Table I. — 110-volt and 220-volt Two-wire Circuits.

Wire Sizes; B. & S. Gauge.		Line Loss in Percentage of the Rated Voltage; and Power Loss in Percentage of the Delivered Power.								
110 V.	220 V.	1	1 1/2	2	3	4	5	6	8	10
	0000	21,550	32,325	43,100	64,650	86,200	107,750	129,300	172,400	215,500
	000	17,080	25,620	34,160	51,240	68,320	85,400	102,480	136,640	170,800
	00	13,550	20,325	27,100	40,650	54,200	67,750	81,300	108,400	135,500
0000	0	10,750	16,125	21,500	32,250	43,000	53,750	64,500	86,000	107,500
000	1	8,520	12,780	17,040	25,560	34,080	42,600	51,120	68,160	85,200
	2	6,750	10,140	13,520	20,280	27,040	33,800	40,560	54,080	67,600
00	3	5,360	8,040	10,720	16,080	21,440	26,800	32,160	42,880	53,600
0	4	4,250	6,375	8,500	12,750	17,000	21,250	25,500	34,000	42,500
1	5	3,370	5,055	6,740	10,110	13,480	16,850	20,220	26,960	33,700
2	6	2,670	4,005	5,340	8,010	10,680	13,350	16,020	21,360	26,700
3										
4	7	2,120	3,180	4,240	6,360	8,480	10,600	12,720	16,960	21,200
5	8	1,680	2,520	3,360	5,040	6,720	8,400	10,800	13,440	16,800
6	9	1,330	1,995	2,660	3,990	5,320	6,650	7,980	10,640	13,300
7	10	1,055	1,582	2,110	3,165	4,220	5,275	6,330	8,440	10,550
8	11	838	1,257	1,675	2,514	3,350	4,190	5,028	6,700	8,380
	12	665	997	1,330	1,995	2,660	3,320	3,990	5,320	6,650
9	13	527	790	1,054	1,580	2,108	2,635	3,160	4,215	5,270
10	14	418	627	836	1,254	1,672	2,090	2,508	3,344	4,180
11	.....	332	498	665	997	1,330	1,660	1,995	2,660	3,325
12	.....	209	313	418	627	836	1,045	1,354	1,672	2,090
13	.....									
14	.....									

Table II. — 500, 1000, and 2000 Volt Circuits.

Wire Sizes; B. & S. Gauge.			Line Loss in Percentage of the Rated Voltage; and Power Loss in Percentage of the Delivered Power.						
500 V.	1000 V.	2000 V.	1	1 1/2	2	2 1/2	3	4	5
	0000	0	97,960	146,940	195,920	244,900	293,880	391,840	489,800
	000	1	77,690	116,535	155,380	194,225	233,970	310,760	388,450
	00	2	61,620	92,430	123,240	154,050	184,860	246,480	308,100
0000	0	3	48,880	73,320	97,760	122,200	146,640	195,420	244,400
000	1	4	38,750	58,125	77,500	96,875	116,250	155,000	193,750
	2	5	30,760	46,140	61,520	76,900	92,280	123,040	153,800
00	3	6	24,370	36,555	48,740	60,925	73,110	97,480	121,850
0	4	7	19,320	28,980	38,640	48,300	57,960	77,280	96,600
1	5	8	15,320	22,980	30,640	38,300	45,960	61,280	76,600
2	6	9	12,150	18,225	24,300	30,375	36,450	48,300	60,750
3									
4	7	10	9,640	14,460	19,280	24,100	28,920	38,560	48,200
5	8	11	7,640	11,460	15,280	19,100	22,920	30,560	38,200
6	9	12	6,060	9,090	12,120	15,150	18,180	24,240	30,300
7	10	13	4,805	7,207	9,610	12,010	14,415	19,220	24,025
8	11	14	3,810	5,715	7,620	9,525	11,430	15,220	19,050
	12	.....	3,020	4,530	6,040	7,550	9,060	12,080	15,100
9	13	.....	2,395	3,592	4,790	5,985	7,185	9,580	11,975
10	14	.....	1,900	2,850	3,800	4,750	5,700	7,600	9,500
11	.....	.....	1,510	2,265	3,020	3,775	4,530	6,040	7,550
12	.....	.....	950	1,425	1,900	2,375	2,850	3,800	4,750
13	.....	.....							
14	.....	.....							

slowly and then more rapidly, as the load decreases. Each machine has its "characteristic" curve of efficiency, showing the ratio of output to input at different loads. Roughly the decrease in efficiency for direct-current machines at half-load varies from 3% to 10% for the smallest sizes. The loss in transmission, due to fall in electrical pressure or "drop" in the line, is governed by the size of the wires, the other conditions remaining the same. For a long-distance transmission plant this will vary from 5% upwards.

With generator efficiency and motor efficiency each 90%, and transmission loss 5%, the combined efficiency is  $0.90 \times 0.90 \times 0.95 = 76.95\%$ .

### Resistances of Pure Aluminum Wire.\*

Conductivity 62 in the Matthiesen Standard Scale. Pure aluminum weighs 167.111 pounds per cubic foot.

Am. Gage, B. & S. No.	Resistances at 70° F.				Am. Gage, B. & S. No.	Resistances at 70° F.			
	Ohms per 1000 Feet.	Ohms per Mile.	Feet per Ohm.	Ohms per Pound.		Ohms per 1000 Feet.	Ohms per Mile.	Feet per Ohm.	Ohms per Pound.
0000	0.07904	0.41730	12652.	0.00040985	19	12.985	68.564	77.05	11.070
000	.09966	.52623	10034.	.00065102	20	16.381	86.500	61.06	17.595
00	.12569	.66362	7956.	.0010364	21	20.649	109.02	48.43	27.971
0	.15849	.83684	6310.	.0016479	22	26.025	137.42	38.44	44.450
1	.19982	1.0552	5005.	.0026194	23	32.830	173.35	30.45	70.700
2	.25200	1.3305	3968.	.0041656	24	41.400	218.60	24.16	112.43
3	.31778	1.6779	3147.	.0066250	25	52.200	275.61	19.16	178.78
4	.40067	2.1156	2496.	.010531	26	65.856	347.70	15.19	284.36
5	.50526	2.6679	1975.	.016749	27	83.010	438.32	12.05	452.62
6	.63720	3.3687	1569.	.026628	28	104.67	552.64	9.55	718.95
7	.80350	4.2425	1245.	.042335	29	132.00	697.01	7.58	1142.9
8	1.0131	5.3498	987.0	.067318	30	166.43	878.80	6.01	1817.2
9	1.2773	6.7442	783.0	.10710	31	209.85	1108.0	4.77	2888.0
10	1.6111	8.5065	620.8	.17028	32	264.68	1397.6	3.78	4595.5
11	2.0312	10.723	492.4	.27061	33	333.68	1760.2	3.00	7302.0
12	2.5615	13.525	390.5	.43040	34	420.87	2222.2	2.38	11627.
13	3.2300	17.055	309.6	.68437	35	530.60	2801.8	1.88	18440.
14	4.0724	21.502	245.6	1.0877	36	669.00	3532.5	1.50	29352.
15	5.1354	27.114	194.8	1.7308	37	843.46	4453.0	1.19	46600.
16	6.4755	34.190	154.4	2.7505	38	1064.0	5618.0	0.95	74240.
17	8.1670	43.124	122.5	4.3746	39	1341.2	7082.0	0.75	118070.
18	10.300	54.388	97.10	6.9590	40	1691.1	8930.0	0.59	187700.

\* Calculated on the basis of Dr. Matthiessen's standard, viz.: The resistance of a pure soft copper wire 1 meter long, having a weight of 1 gram = 0.141729 International Ohm at 0° C.  
(From Aluminum for Electrical Conductors; Pittsburgh Reduction Co.)

### ELECTRIC RAILWAYS.

While 600 volts is still maintained as a standard for street railway systems, experience has shown that the most economical operation of high-speed suburban and interurban railroads can be obtained with 1200 to 1500 volts on the trolley. Steam railroad electrifications will, however, be accomplished most satisfactorily with 2400 or 3000 volts direct current.

#### Schedule Speeds, Miles per Hour.

##### CITY SERVICE.

Max. Speed.	Stops per Mile.							
	1	2	3	4	5	6	7	8
15.....	10.8	9.9	9.3	8.7	8.3	7.9	7.5	7.2
20.....	13.7	12.1	11.1	10.3	9.6	9.0	8.6	8.1
25.....	16.3	14.2	12.7	11.5	10.6	9.9	9.3	8.7
30.....	18.5	15.6	13.8	12.4	11.3	10.5	9.8	9.2



## INTERURBAN SERVICE.

Max. Speed.	Miles between Stops.								
	1/2	3/4	1	1.5	2	3	4	5	10
30.....	14.0	15.5	16.7	18.5	19.7	21.0	22.0	22.5	23.9
40.....	15.4	18.1	20.0	22.7	24.5	26.7	28.0	28.9	30.8
50.....	16.2	19.5	21.9	25.6	27.9	31.0	32.9	34.2	37.2
60.....	17.0	20.8	23.6	27.9	30.9	34.8	37.5	39.3	43.6

The figures in the above tables include stops of 5 seconds each for the city service and of 15 seconds for the interurban service, besides a 15% margin for line drop and traffic delays. The ratio of acceleration is approximately 1.5 miles per hour per second for the city service and 1.2 miles per hour per second for the interurban service, the braking being 1.5 miles per hour per second and the coasting approximately 10% of the running time exclusive of stop.

**Train Resistance.** (General Electric Co.)—The horse-power output at the rim of the wheels is equal to,

$$\text{H. P.} = \frac{T \times F \times \text{Feet}}{33,000 \times \text{Minutes}} = \frac{T \times F \times V}{375}.$$

When reduced to Kilowatts,

$$\text{Kw.} = \frac{T \times F \times V \times 746}{375 \times 1000} = \frac{2 \times T \times F \times V}{1000} \text{ approx.}$$

The kilowatt input to train is equal to,

$$\text{Kw.} = \frac{2 \times T \times F \times V}{1000 \times \text{Eff.}}$$

Where  $T$  = Total weight of train in tons.

$F$  = Train resistance, including that due to grades and curves, in lbs. per ton.

$V$  = Speed in miles per hour.

Eff = Efficiency of motors at speed  $V$ .

The train resistance may be found from the following formula:

$$F = \frac{50}{\sqrt{T}} + 0.03 V + \frac{0.002 V^2}{T} A \left( 1 + \frac{N-1}{10} \right)$$

Where  $F$  = Train resistance in lbs., per ton.

$T$  = Total weight of train in tons.

$V$  = Speed in miles per hour.

$A$  = End cross-section in sq. ft.

$N$  = Number of cars in train.

$\frac{50}{\sqrt{T}}$  is limited to a value of 3.5.

**Tractive Resistance of a 28-ton Electric Car** (Harold H. Dunn, Bull. 74, Univ'y of Ill. Expt. Station, April, 1914).—Mean of all tests:

Miles per hr..	5	10	15	20	25	30	35	40	45
Lb. per ton..	5.25	6.80	8.62	10.75	13.03	15.75	18.75	22.13	26.12

Two formulæ have been derived from the results:

$$R = 4 + 0.222 S + 0.00582 S^2.$$

$$R = 4 + 0.222 S + 0.00181 \frac{A}{W} S^2.$$

$A$  = cross-sectional area of the car in sq. ft.  $W$  = weight of the car in tons.

The formulæ should not be used beyond the limit of 45 miles per hour.

**Rates of Acceleration.**—Electric Locomotive Passenger Service, 0.3 to 0.6 mile per hour per second.

Electric Motor Cars, Interurban Service, 0.8 to 1.3 miles per hour per second.

Electric Motor Cars, City Service, 1.5 miles per hour per second.

Electric Motor Cars, Rapid Transit Service, 1.5 to 2.0 miles per hour per second.

Highest Practical Rate, 2.0 to 2.5 miles per hour per second.

**Safe Maximum Speed on Curves.**—

Radius of Curve, Ft.	10,000	5000	2000	1000	500	200	100	50
Speed, miles per hr.,	100	75	50	35	25	15	10	6

The above values apply only when full elevation is given the outer rail. For city service such elevation is not possible and the maximum speed will, therefore, be less under such conditions. The same restriction applies with steel wheel flanges of  $\frac{3}{4}$  inch or less.

**Coefficient of Adhesion.**—The following are the average values of the coefficient of adhesion between wheels and rails, based on a uniform torque:

Clean, dry rail,	30%.
Wet rail,	18% ; with sand, 22%.
Rail covered with sleet,	15% ; with sand, 20%.
Rail covered with dry snow,	10% ; with sand, 15%.

**Electrical Resistance of Steel Rails.**—The resistance of steel rails varies considerably, due to the difference in chemical composition. Ordinary traction rails have a specific resistance averaging 12 times that of copper, while for contact rails (third rails) the average is only 8 times. The values given in the following table are in ohms at 75° F. and with no joints.

Weight of Rails, Lbs. per Yard.	Actual Area, Sq. In.	Actual Area in Circular Mils.	Resistance per Mile, 8 to 1 Ratio.	Resistance per Mile, 12 to 1 Ratio.
40.....	3.92	4,918,300	0.09118	0.13395
45.....	4.42	5,627,700	0.07915	0.11905
50.....	4.90	6,238,800	0.07135	0.10710
60.....	5.88	7,486,600	0.05955	0.08920
70.....	6.86	8,734,400	0.05105	0.07660
75.....	7.35	9,230,900	0.04780	0.07185
80.....	7.84	9,982,100	0.04465	0.06695
90.....	8.82	11,229,900	0.03975	0.05955
100.....	9.80	12,477,700	0.03750	0.05365

**Resistance of Rail Bonds.**—The resistance of bonded rails will vary, depending on the amount of contact made by the splice bars and rail ends, but in selecting bonds this element of the return circuit should be disregarded, as it is quite unreliable and frequently negligible.

Size of Conductor.	Diameter of Terminal, in Inches.	Resistance per In. of Conductor, 75° Fahr.	Carrying Capacity, Amp.
0.....	$\frac{1}{2}$	.00000829	210
00.....	$\frac{5}{8}$	.00000657	265
000.....	$\frac{3}{4}$	.00000521	335
0000.....	$\frac{7}{8}$	.00000414	425
250,000 C. M.....	$\frac{7}{8}$	.00000350	500
300,000 C. M.....	1	.00000275	600
350,000 C. M.....	1	.00000250	700
400,000 C. M.....	1	.00000219	800
450,000 C. M.....	1	.00000196	900
500,000 C. M.....	1	.00000175	1000

**Electric Locomotives.**—In selecting an electric locomotive the principal points to be determined are the weight of the locomotive, the type and capacity of the equipment, and the mechanical features. The weight upon the drivers must be enough to pull the heaviest trains under the most adverse conditions. Therefore the weight of the heaviest train, the maximum grade and curvature must be ascertained. It must be known whether the locomotive is expected to start the train under these conditions, or whether it will start upon the level and only meet maximum grade conditions when running.

In order to determine the motor equipment all the data of the service conditions are required, such as the speed required under various conditions of load and grade. The maximum free-running speed will be approximately 50 to 75 per cent greater than the rated full load speed. Mechanical limitations must also be considered, such as track clearances, limiting weight on drivers, type of couplings, etc.





## PRINCIPAL STEAM RAILROAD ELECTRIFICATIONS IN AMERICA. (Compiled by General Electric Co., 1914.)

Name of Road and Section Electrified.	Length of Route, Miles.	System of Electrification.	Trolley or Third Rail.	Locomotives.			Mechanical Transmission.
				Cont. Rating.* T. E. † Lb.	M.P.H.	Max. T. E. Lb.	
1. Baltimore & Ohio, Baltimore, Md. Baltimore Tunnels	3.3	600-v. d-c.	Third rail	..... 12,200	..... 20.1	48,000 20,000 60,000	Gearless. Geared. Twin geared.
2. New York Central R.R., New York to Harmon	34	600-v. d-c.	Third rail	7,800 11,400 14,000	51.6 57.5 53.5	42,500 67,200 75,000	Gearless bipolar. Gearless bipolar. Gearless bipolar.
3. New York, New Haven & Hartford R.R., New York to New Haven	74	Single-phase 11,000-v. 25-cyc. 600-v. d-c. in N. Y. City.	Catenary Third rail	6,400 11,800 12,000 14,800	66 45 42 14.5	20,000 40,000 40,000 40,000	Gearless quill drive. Geared. Geared twin motors. Geared.
4. Grand Trunk Ry. Co., St. Clair Tunnel Co., Pt. Huron, Mich., St. Clair Tunnel	2.5	Single-phase, 6600-v., 25-cyc.	Catenary	18,500	13.5	44,000	Twin geared.
5. Great Northern R.R., Cascade Tunnel, Washington	4.0	Three-phase 6600-v., 25-cyc.	Two-wire direct suspension	34,800	15.18	69,000	Twin geared.
6. Michigan Central R.R., Detroit River Tunnel, Detroit, Mich.	6.25	600-v. d-c.	Third rail	17,200	14.3	60,000	Twin geared.
7. Boston & Maine R.R., North Adams, Mass., Hoosac Tunnel	7.92	Single-phase 11,000-v., 25-cyc.	Catenary	21,000	25.3	68,000	Geared.
8. Penn. Tunnel & Terminal R.R.— Pennsylvania R.R. into New York City	15	600-v. d-c.	Third rail	20,000 12,300	33.7 54.3	75,000	Diagonal side rod—each motor driving two ax- les through jack shaft.
9. Butte, Anaconda & Pacific R.R., Butte to Anaconda, Montana	30	2400-v. d-c.	Catenary	25,000 16,200	16.2 24.6	48,000	Twin geared.
10. Norfolk & Western R.R., Bluefield to Elkhorn, W. Va.	30	Split-phase, 11,000-v.	Catenary	20,000 34,300	28.3 14.2	62,500	Twin-motor twin- geared side rod.
11. Canadian Northern, Montreal, Can.	9	2400-v. d-c.	Catenary	16,200	24.9	49,800	Twin geared.

\* "Continuous Rating," which means the rating which can be continually developed without overheating the motors.

† "Pounds Tractive Effort," in which the drawbar pull is measured.

**Relative Efficiencies of Electric Railway Distributing Systems.**—The table on p. 1417 shows the approximate all-day combined efficiencies from prime mover to train wheels for various methods of trunk line electrifications. The trains are supposed to be handled by electric locomotives, and in each instance a considerable length of line is contemplated, making it necessary to have a 100,000-volt high-tension primary distribution or a multiplicity of power sources.

Space will not permit a complete treatment of the subject of Electric Railways in this work. For further information consult: "American Handbook for Electrical Engineers"; Standard Handbook for Electrical Engineers"; "Foster's Electrical Engineer's Pocket Book"; Burch, "Electric Traction for Railway Trains"; Harding, "Electric Railway Engineering."

### ELECTRIC WELDING.

Electric welding is divided into two general classes, arc heating and resistance heating.

**Arc Welding.**—In this process the heat of the arc is utilized to bring the metals to be welded to the melting temperature, when the joint is filled with molten metal, usually introduced in the form of a rod. This system is usually operated by direct current, and as the positive side of a direct current arc generates heat at a rate approximately three times that of the negative side, the positive side is used for performing the welding operation.

Two kinds of arcs may be used for this class of welding, the carbon arc and the metallic arc. The former requires an e. m. f. varying from 50 to 100 volts and the value of the current is varied over a range of 100 to 750 amperes, 300 being the average. The metallic arc, however, requires an e. m. f. of only from 15 to 30 volts, the length of the arc being very short as compared with the carbon arc.

The arc should be as stable as possible, and the current should, therefore, be of a constant value. The regulation may be accomplished by inserting resistance in series in the circuit, but this system is naturally very wasteful and greater economy may be obtained by providing motor-generator sets, with the generator of the variable voltage type.

The following costs, Table I (from *Electrical World*) were compiled from the records of an electric railway repair shop:

**TABLE I.**  
**Data on Electric Welding Repairs in Railway Shops.**

	Time in Minutes.	Kw.	Average Costs.
Gear-case lugs . . . . .	10	6	\$0.07
Armature shaft (broken) 2-in. . . . .	60	20-30	0.80
Dowel-pin holes . . . . .	5-12	4-8	0.07
Broken motor cases . . . . .	150-200	75-90	4.98
Broken lugs on a compressor cover, doors and grease-cup hinges . . . . .	2-5	1-3	0.03
Broken truck frames . . . . .	30-60	20-35	0.63
Worn bolt holes in motors and trucks . . . . .	5-10	3-5	0.05
Enlarged and elongated holes in brake levers . . . . .	2-4	1 1/2-3	0.03
Armature shafts, 2-in., worn in journals . . . . .	120-180	60-90	3.75
Armature shafts, worn in keyways . . . . .	10-15	7-12	0.10
Armature shaft, worn thread . . . . .	20-30	10-15	0.24
Air-brake armature shafts (broken) . . . . .	20-30	10-20	0.27
Leaking axle boxes . . . . .	5-15	3-7	0.08

**Resistance Welding.**—Resistance welding is done by the heat developed by a large amperage carrying through the joining metals by means of a low voltage. Single-phase alternating current is generally used for the operation, which may be broadly divided into two classes—butt-welding and spot-welding. The former covers all work on which the ends or the sides of the material are welded together, while spot-welding is used for joining metal sheets together at any point by a spot the size of a rivet, without punching holes or using rivets.

For resistance welding a very low voltage is used, varying from 2 to 8 volts, the line voltage being stepped down by special transformers.

The current consumption, in amperes, varies with the work and the time taken to make the weld.

The following tables (from *Iron Trade Review*) give the cost of resistance welding. Table II gives the results obtained by butt-welding round stock ranging from 1/4 to 1 inch diameter, in the shortest and longest time possible. The difference in current consumption is very great and in most cases the shorter time in seconds was the most economical of the two, although neither is the most economical rate at which the material can be welded.

**TABLE II.—Shortest and Longest Butt-welding Periods.**

Size, In.	Time, Seconds.	Current Amperes.	Volts per Square Inch.	Size, In.	Time, Seconds.	Current Amperes.	Volts per Square Inch.
1/4	2.7	1960	39.5	5/8	3.5	9400	33.7
1/4	5	1645	35.5	5/8	10.85	5510	18.85
3/8	4	4330	45.5	3/4	4	10000	16.26
3/8	5.27	2190	19.7	3/4	22.2	9400	19.7
1/2	4	6600	36.6	7/8	7	11900	27.7
1/2	15.8	1800	13	7/8	17	10550	19.6
9/16	3.6	8400	8	1	33	7740	10.35
9/16	21.5	3400	12.25	1	114	4450	16.1

Table III contains the results of tests made to determine the cost of power for making electric butt welds on material ranging from 1/4 to 2 inches in diameter.

**TABLE III.—Cost of Power.**

Area, Sq. In.	Kw.	Welding Time, Seconds.	Cost per 1000 Welds*	Area, Sq. In.	Kw.	Welding Time, Seconds.	Cost per 1000 Welds*
0.05	5	5	\$0.07	0.79	18	30	\$1.50
0.11	7 1/2	6	0.13	0.99	20	30	1.66
0.20	8	10	0.22	1.23	26	40	2.89
0.31	10	12	0.33	1.77	40	60	6.67
0.44	12	15	0.50	2.41	45	70	8.75
0.60	15	20	0.83	3.14	56	80	12.44

Table IV gives the time, power and cost per 100 spot-welds, with current at 1/4 cent per Kw.-hr., for welding Nos. 10 to 28 gage sheets.

**TABLE IV.—Cost of Welding.**

Gage.	Kw.	Time in Seconds.	Cost per 1000 Welds, Cents.*	Gage.	Kw.	Time in Seconds.	Cost per 1000 Welds, Cents.
10	18	1.5	3.5	20	9	0.7	2
12	16	1.3	3	22	8	0.6	1.75
14	14	1.0	2.75	24	7	0.5	1.5
16	12	0.9	2.5	26	6	0.4	1.25
18	10	0.8	2.25	28	5	0.3	1

\*Current at 1 cent per Kw.-hr.

### ELECTRIC HEATERS.

Wherever a comparatively small amount of heat is desired to be automatically and uniformly maintained, and started or stopped on the instant without waste, there is the province of the electric heater.

The elementary form of heater is some form of resistance, such as coils of thin wire introduced into an electric circuit and surrounded with a substance which will permit the conduction and radiation of heat, and at the same time serve to electrically insulate the resistance.

This resistance should be proportional to the electro-motive force of the current used and to the equation of Joule's law:

$$H = I^2 R t \times 0.24,$$



where  $I$  is the current in amperes;  $R$ , the resistance in ohms;  $t$ , the time in seconds; and  $H$ , the heat in gram-centigrade units.

Since the resistance of metals increases as their temperature increases, a thin wire heated by current passing through it will resist more, and grow hotter and hotter until its rate of loss of heat by conduction and radiation equals the rate at which heat is supplied by the current. In a short wire, before heat enough can be dispelled for commercial purposes, fusion will begin; and in electric heaters it is necessary to use either long lengths of thin wire, or carbon, which alone of all conductors resists fusion. In the majority of heaters, coils of thin wire are used, separately embedded in some substance of poor electrical but good thermal conductivity.

**Relative Efficiency of Electric and of Steam Heating.** — Suppose that by the use of good coal, careful firing, well-designed boilers and triple-expansion engines we are able in daily practice to generate 1 H.P. at the fly-wheel with an expenditure of  $2\frac{1}{2}$  lb. of coal per hour.

We have then to convert this energy into electricity, transmit it by wire to the heater, and convert it into heat by passing it through a resistance-coil. We may set the combined efficiency of the dynamo and line circuit at 85%, and will suppose that all the electricity is converted into heat in the resistance-coils of the radiator. Then 1 brake H.P. at the engine = 0.85 electrical H.P. at the resistance coil = 1,683,000 ft.-lb. energy per hour = 2180 heat-units. But since it required  $2\frac{1}{2}$  lbs. of coal to develop 1 brake H.P., it follows that the heat given out at the radiator per pound of coal burned in the boiler furnace will be  $2180 \div 2\frac{1}{2} = 872$  H.U. An ordinary steam-heating system utilizes 9652 H.U. per lb. of coal for heating; hence the efficiency of the electric system is to the efficiency of the steam-heating system as 872 is to 9652, or about 1 to 11. (*Eng'g News*, Aug. 9, '90; Mar. 30, '92; May 15, '93.)

**Heat Required to Warm and Ventilate a Room.** — The heat required to raise the temperature of a given space or room to a certain value depends upon the ventilation, the character of the walls, the dimensions, proportions of the room, etc. One watt-hour of electrical energy will raise the temperature of one cubic foot of air (measured at 70°) 191° F., or 1 watt will raise the temperature of a cubic foot of air at the rate of 0.0531° F. per second, or approximately 3.2° per minute. In addition to raising the temperature of the air to the desired value, the loss of heat through conduction and ventilation must be supplied. (See Heating and Ventilation.)

**EXAMPLE.** Assume a room of a capacity of 3000 cu. ft., in which the air is changed every 20 minutes, the temperature to be maintained 30° above the outside air.

$3000 \div 20 = 150$  cu. ft. per minute.

$(150 \times 30) \div 3.2 = 1406$  watts necessary to supply the ventilation loss. To begin with, to raise the air in the room 30° will require

$$(3000 \times 30) \div 191 = 471 \text{ watt-hours}$$

and therefore the total energy used during the first hour will be  $1406 + 471 = 1877$  watt-hours or 1.88 Kw.-hours.

**Domestic Heating.** — Electric heating is extensively used for household cooking apparatus. The time taken to heat water in any quantity to any definite temperature not exceeding boiling point can be determined by the formula:

$$t = \frac{V(T_2 - T_1) 1831}{P \times \text{Eff.}}$$

Where  $t$  = time in minutes,  $V$  = number of pints,  $T_1$  = initial temperature, °F.,  $T_2$  = final temperature, °F.,  $P$  = energy consumption in watts, Eff. = Efficiency of cooking utensil, per cent.

**EXAMPLE.** To heat 1 pint of water 100° F. with a 220-watt heater with 50% efficiency, time =  $(1 \times 100 \times 1831) \div (220 \times 50) = 16.6$  min.

The following table (compiled by the National Electric Light Association) gives the watts consumed and cost of operation of different domestic heating devices, the cost of current being at the rate of 5 cents per Kw.-hr.

### Cost of Operation of Domestic Heating Appliances.

Apparatus.	Watts.	Cents per hr.
Broilers, 3 heat*.....	300 to 1200	1.5 to 6
Chafing dishes, 3 heat.....	200 to 500	1 to 2.5
Coffee percolators for 6-in. stove.....	100 to 440	0.5 to 2.2
Curling-iron heaters.....	60	0.3
Double boilers for 6-in., 3-heat stove.....	100 to 440	0.5 to 2.2
Flatiron (domestic size), 3 lb.....	275	1
Flatiron (domestic size), 4 lb.....	350	1.4
Flatiron (domestic size), 5 lb.....	400	2
Flatiron (domestic size), 6 lb.....	475	2.4
Flatiron (domestic size), 7.5 lb.....	540	2.7
Flatiron (domestic size), 9 lb.....	610	3.05
Frying kettles, 8 in. diameter.....	825	4.125
Griddle-cake cookers, 9 in. by 12 in., 3-heat	330 to 880	1.7 to 4.4
Griddle-cake cookers, 12 in. by 18 in., 3-heat	500 to 1500	2.5 to 7.5
Ornamental stoves.....	250 to 500	1.25 to 2.5
Ovens.....	1200 to 1500	6 to 7.5
Plate warmers.....	300	1.5
Radiators.....	700 to 6000	3.5 to 30
Ranges: 3-heat, 4 to 6 people.....	1000 to 4515	5 to 22
Ranges: 3-heat, 6 to 12 people.....	1100 to 5250	5.5 to 26
Ranges: 3-heat, 12 to 20 people.....	2000 to 7200	10 to 36
Toasters, 9 in. by 12 in., 3-heat.....	330 to 880	1.6 to 4.4
Urns, 1-gal., 3-heat.....	110 to 440	0.5 to 2.2
Urns, 2-gal., 3-heat.....	220 to 660	1.1 to 3.3

Experience has shown that 300 watt-hours per meal per person is a liberal allowance for electric cooking; or in a family of five, four kilowatt hours per day is an average.

### ELECTRIC FURNACES.

In the combustion furnace, no matter what form of fuel is used, the temperature cannot exceed 2000° C. (3632° F.), and for higher temperatures the electric furnace must be used. The intensity of the heat in this type of furnace depends on the amount of current that passes, and as most substances are conductors when hot, the degree of intensity possible is theoretically unlimited. In practice, however, the conducting substance begins to fuse when heated to its melting point, and one is then confronted with the physical difficulty of keeping the conducting medium in place, or, if this be accomplished, the conducting medium ultimately vaporizes, the gaseous materials escape, and heat is thus carried away from the furnace as rapidly as it is supplied. The temperature of the electric arc, which is somewhere between 3600° and 4000° C. (6512° - 7232° F.), is perhaps the highest temperature attainable at present.

Electric furnaces may be divided in two broad classes, *arc furnaces* and *resistance furnaces*. In the former the heat is generated by passing an electric current through the space between the ends of two electrodes, forming the so-called arc. In the resistance furnace the heat is generated in the interior of a body due to its electrical resistance.

There are three typical forms of arc furnaces, their common feature being that most and sometimes all of the heat is transmitted to the material by radiation, which extends in all directions. In all the furnaces the arc must be started by a quick movement of the electrodes and afterwards these must be continuously fed together as they are consumed.

The chief characteristics of the three main types of arc furnaces are:

1. The direct-heating type, in which two or more electrodes are used and the heating is accomplished by conduction and radiation. The current passes from one electrode down through the slag, across through the bath and up through the slag to the other electrode. The Heroult furnace belongs to this type.

The Girod furnace is also of the direct-heating type, the current arcing from the electrodes, which are connected to one side of the circuit, to a fixed electrode in the bottom.

\* The apparatus can be set at three different heats or temperatures.

2. The indirect-heating type. To this type belongs the Stassano furnace, in which the arc extends between two or more carbon electrodes above the charge, and therefore passes over but does not come in contact with the charge, the heating being accomplished by radiation.

3. The smothered type, in which the arc extends from the end of the upper electrode, which extends beneath the surface of the charge, to the lower fixed electrode in the bottom of the furnace.

The direct and indirect heating arc furnaces are extensively used for melting and refining metals, while examples of the smothered type are the ferro-silicon and calcium carbide furnaces.

Resistance furnaces may also be divided in two distinct types, those of direct and indirect heating.

1. Direct heating. In these the heat is produced in the material by its own resistance, and enters the material at the highest efficiency.

The material may be placed in a channel between two electrodes at the ends which lead the current to and from it, the charge being surrounded with insulating material to reduce the loss of heat. The Acheson graphite furnaces are of this type.

Under this classification also come the induction furnaces in which the terminal electrodes are eliminated and the heat generated solely by induction. The furnace consists essentially of an iron core, around one leg of which is wound a primary winding enclosed in a refractory case and usually cooled by means of forced draft. The annular hearth surrounds this primary coil and is separated from it by means of refractory material. This hearth contains the metal and acts as a secondary winding of one turn. The voltage induced in this turn is quite small so that the energy transformed from the primary coil results in a very large current in the secondary, which heats the metal and thus nearly all the electrical energy is converted into heat in the metal to be melted. The Kjellin and the Rochling-Rodenhauser furnaces belong to this type. They are extensively used for steel refining.

2. Indirect heating furnaces have the heat generated in an internal or external resistor and it is transferred to the charge by conduction and radiation. Such furnaces are used for small moderate temperature work.

### Uses of Electric Furnaces.

*Pig Iron.* — When the electric furnace is used for smelting of iron ore it is only necessary to supply enough carbon for the reduction, this amount being approximately one-third of what is required in the ordinary blast furnace for both the heating and reduction. From repeated trial runs with electric smelting furnaces in Norway and Sweden it has been found that coke as a reducing agent does not give satisfactory results, and charcoal is therefore used exclusively.

The table on p. 1424 gives a summary of the most important figures relating to the economical results which were obtained with the electric iron ore furnaces in Sweden.

*Steel Refining.* — Electric furnaces are used in the manufacture of crucible quality steel, and the number is constantly increasing, both arc and induction furnaces being in general use.

The following data as to the cost of electric steel refining are taken from an article in *Stahl und Eisen*, April 10, 1913. This article gives the results which have been obtained in Germany by the Heroult furnace and it contains a discussion of electric steel production from a large-industry point of view.

The total refining cost must include many items as well as the cost of current; for example, the cost of fluxes (ore, lime, sand, etc.), the additions of ferro-alloys, relining, maintenance, and repairs, electrode consumption, wages, and, finally, interest and depreciation. The totals of these items and the cost of current, which is the largest item, are given below:

#### Total Refining Costs (Per Ton).

	5-ton		10-ton		15-ton		20-ton	
	Basic.	Acid.	Basic.	Acid.	Basic.	Acid.	Basic.	Acid.
Total costs . . .	\$2.79	\$1.79	\$2.45	\$1.45	\$2.28	\$1.34	\$2.15	\$1.25
Cost of current	1.19	0.77	1.07	0.59	1.01	0.54	0.95	0.48

The figures are based on prevailing market prices. Current is taken



## Data on Electric Smelting of Pig Iron in Sweden.

	Nov. 15, 1910, to May 29, 1911.	Aug. 4, 1911, to June 21, 1912.	Aug. 12, 1912, to Sept. 30, 1912.	October to December, 1912.
Ore, concentrates and briquettes, kg.	4,336,338	7,917,214	1,406,530	2,914,830
Limestone . . . . .kg.	345,405	647,479	108,150	169,944
Charcoal . . . . .hl.*	65,474	107,282	21,859	44,934
Coke . . . . .kg.	.....	70,854	.....	.....
Elec. energy, kw. hrs.	6,339,131	10,845,180	1,939,073	3,957,565
Iron in ore, per cent.	60.79	60.75	68.67	65.38
Iron produced . .kg.	2,636,098	4,809,670	965,915	1,905,865
Slag per ton of iron . . . . .kg.	350	324	192	.....
Electrodes per ton of iron, gross .kg.	10.00	6.08	3.02	2.78
Electrodes per ton of iron, net . .kg.	4.95	5.17	3.02	2.78
Charcoal per ton of iron . . . . .hl.	24.84	22.31	22.63	23.58
	Hr. Min.	Hr. Min.	Hr. Min.	Hr. Min.
Working time . . . .	4,441 20	7,218 23	1,173 08	2,158 30
Repairs . . . . .	236 53	506 07	13 47	49 30
Repairs in per cent. of total time . . . .	5.06	6.55	1.16	2.24
Average load, kw. . .	1,427	1,502	1,653	1,833
Kw.-hrs. per ton of iron . . . . .	2,405	2,255	2,007	2,076
Iron per kw. year, tons . . . . .	3.64	3.88	4.36	4.22
Iron per h.p. year, tons . . . . .	2.68	2.86	3.20	3.10

\* 1 hectoliter = 3.53 cu. ft. = 2.84 U. S. bushels.

at 0.595c. per Kw.-hr., which is a figure that should be easy of attainment for most steel plants. The time per heat is taken as  $2\frac{1}{4}$  to  $2\frac{1}{2}$  hours. Three-phase furnaces are considered, and in the installation cost of the plant must be included transformers, cables, and switchboards. The amount of current required is as follows:

Size of Furnace, Tons	1	2	5	10	25
Kilowatts . . . . .	300-350	400-450	750-800	1000-1200	3000-3500

*Ferro-Alloys.* — The electric furnace has clearly demonstrated its advantages in the manufacture of ferro-alloys. The production of a ferro-alloy low in carbon or with a high percentage of the alloying element is limited in the blast furnace by three difficulties — first, the temperature is too low for the reduction of some of the oxides of the alloying metals; second, it is difficult to obtain an alloy containing a high percentage of the special metal; and third, it is impossible to produce a ferro-alloy low in carbon, because of the great excess of carbon in the charge. With the crucible, owing to the small scale of operation necessary, the process is expensive. Owing to the temperature limitation, certain oxides can not be reduced and metals of high melting point can not be melted; it is difficult to obtain an alloy with a high percentage of the special metal; and if a graphite crucible is used, the percentage of carbon tends to be high in the ferro-alloy.

*Non-ferrous Metals.* — In the metallurgy of non-ferrous metals the electric furnace has had a greater application for the treatment of zinc ores than in the metallurgy of any of the other non-ferrous metals except aluminum. Since 1885, when an electric furnace for the treatment of zinc ores was patented by the Cowles brothers, experimental work has been done on a very large scale. However, the process has not been applied to any great extent because of the difficulty of condensing the zinc vapor produced in smelting in the electric furnace, and

so it may be said that the electric smelting of zinc ores is yet in the experimental stage.

**Silundum**, or silicified carbon, is a product obtained when carbon is heated in the vapor of silicon in an electric furnace. It is a form of carborundum, and has similar properties; it is very hard, resists high temperatures, and is acid-proof. It is a conductor of electricity, its resistance being about three times that of carbon. It can be heated in the air up to 1600° C. without showing any sign of oxidation. At about 1700°, however, the silicon leaves the carbon and combines with the oxygen of the air. Silundum can not be melted. The first use to which the material was applied was for electric cooking and heating. For heating purposes the silundum rods can be used single, in lengths up to 32 in., depending on the diameter, as solid, round, flat, or square rods or tubes, or in the form of a grid mounted in a frame and provided with contact wires.—(*El. Review*, London. *Eng. Digest*, Feb., 1909.)

### PRIMARY BATTERIES.

Following is a partial list of some of the best known primary cells or batteries.

Name.	Elements.		Electrolyte.	Depolarizer.	E.M.F. volts.
	-	+			
Daniell.....	Cu	Zn	Dilute H <sub>2</sub> SO <sub>4</sub>	Concent. CuSO <sub>4</sub>	1.07
Gravity.....	Cu	Zn	ZnSO <sub>4</sub>	Concent. CuSO <sub>4</sub>	1.
Grove.....	Pt	Zn	Dilute H <sub>2</sub> SO <sub>4</sub>	HNO <sub>3</sub>	1.9
Fuller.....	C	Zn	Dilute H <sub>2</sub> SO <sub>4</sub>	K <sub>2</sub> Cr <sub>2</sub> O <sub>7</sub>	2.1
Edison-Lalande....	Cu	Zn	Conc. NaOH	CuO	0.7-0.9
Leclanche.....	C	Zn	NH <sub>4</sub> Cl	MnO <sub>2</sub>	1.4
Clark.....	Pt	Zn	ZnSO <sub>4</sub>	Hg <sub>2</sub> SO <sub>4</sub>	1.44
Weston.....	Pt	Cd	CdSO <sub>4</sub>	Hg <sub>2</sub> SO <sub>4</sub>	1.02
Dry battery.....	C	Zn	Various electrolyte pastes.		1-1.8

The gravity cell is used for telegraph work. It is suitable for closed circuits, and should not be used where it is to stand for a long time on open circuit.

The Fuller cell is adapted to telephones or any intermittent work. It can stand on open circuit for months without deterioration.

The Edison-Lalande cell is suitable for either closed or open circuits.

The Leclanche cell is adapted for open circuit intermittent work, such as bells, telephones, etc.

The Clark and Weston cells are used for electrical standards. The Weston cell has largely superseded the Clark.

Dry cells are in common use for house service, igniters for gas engines, etc.

Batteries are coupled in series of two or more to obtain an e.m.f. greater than that of one cell, and in multiple to obtain more amperes without change of e.m.f.

Spark coils, or induction coils, with interrupters, are used to obtain ignition sparks for gas engines, etc.

### ELECTRIC ACCUMULATORS OR STORAGE BATTERIES.

Secondary or storage batteries may be divided in two general classes: viz., the lead battery and the Edison alkaline battery. They are composed of a number of cells connected in series or multiple. The voltage is independent of the size of the cell and is a function of the electro-chemical properties used for the electrodes and electrolytes, being approximately two volts per cell. The current, however, is approximately proportional to the surface of the electrodes that are submerged in the electrolyte.

**Lead Batteries.**—The lead battery consists of two electrodes, the positive and negative, immersed in the electrolyte. The two electrodes are sponge lead (Pb) for the negative, and peroxide of lead (PbO<sub>2</sub>) for the positive, these forming the active couple, the electrolyte being dilute sulphuric acid. The two sets of electrodes are called an element, and they can be readily distinguished by their colors, the positive per-

oxide plate being of a velvety brown chocolate color and the negative lead sponge plate of a light gray.

Inside of the cell the current starts from the negative electrode toward the positive, and the positive electrode, therefore, is that portion of the battery from which the electric current passes out into the load circuit, this being termed "discharge," as compared to the storing of energy, which is termed "charge." When the cell gives out current, the elements gradually change in composition, becoming mixtures or compounds of lead and lead sulphate at the negative electrode, and lead peroxide and lead sulphate at the positive electrode, the chemical change caused by the giving out of electrical energy being a gradual formation of lead sulphate.

Lead batteries are made with two different types of plates, the "formed" or Planté plate, and the "pasted" or Faure plate. In the former, the active material is formed electro-chemically on the surface of the plate body, while in the latter it is first applied mechanically in the form of lead oxide and afterward subjected to the forming process. As a rule the negative plates are always of the Faure type. Positive Planté plates have a long life, while the life of positive Faure plates is limited to a considerable extent by the number of charges. The latter, however, give a greater capacity for the same weight than the formed plate, and are, therefore, used where light weight is required, such as for electric vehicles. Positive plates have ordinarily a shorter life than negative.

The capacity of a storage battery is measured in ampere-hours, and varies with the discharge rate. An arbitrary standard of the 8-hour rate is now universally adopted, but if the rate is increased, the capacity is diminished. So, for example, at a one-hour discharge rate only about half the number of ampere-hours can be obtained from a cell that it can supply at the 8-hour rate. An 80-ampere-hour battery thus means one which will discharge 10 amperes continuously for eight hours without falling below the minimum allowable voltage.

When a battery is being discharged, the voltage sinks gradually and it should never be discharged below some fixed limit, because an excessive quantity of sulphate will then form, which may injure the plates both electrically and mechanically, tending to crack and loosen the active material. This condition is indicated by the deposit of white sulphate on the surfaces of the plates. The voltage at which a lead battery is assumed to be completely discharged depends on the discharge rate, and may be computed from the formula

$$E = 1.66 + 0.0175 t$$

where  $t$  = time of discharge in hours.

Thus for an 8-hour rate the discharge should be stopped when the voltage has dropped to 180, while for a 1-hour rate, it should be stopped when it has dropped to 168.

The voltage rises gradually during the charging from about 2.15 per cell at the beginning to about 2.55 at the end. The rate of charging is usually specified by the manufacturer. In certain instances it is equal to the 8-hour discharge rate, while in others the instructions may be to start the charge between the 3- and 5-hour rate, reducing the current to the 8-hour rate as soon as the plates gas freely. The time required for a charge will, of course, depend upon the amount of the previous discharge. If this has been two-thirds of the rated capacity of the battery, about three hours at the starting rate and an hour and a half or two hours at the finishing rate will be necessary; *i.e.*, from 10 to 15 per cent more charge than the amount taken out on the discharge is ordinarily required.

At regularly weekly or bi-weekly intervals the battery should be given an overcharge for the purpose of equalizing all cells, reducing all sulphate, and keeping the plates in good general condition. Such overcharge is a regular charge continued until the voltage does not show any rise for four or five consecutive readings 15 minutes apart, all cells then gassing freely. A charging voltage of 2.7 volts should be provided for such overcharges.

The specific gravity of the electrolyte, will reach a maximum in the same manner as the voltage, and readings of this in the various cells of the battery should be taken toward the end of the charge



with a hydrometer. These readings will act as a check on those taken on the voltage, and while it may not be found practicable to do this every time the battery is charged, it is very important and should be done at least once a week. If batteries are used intermittently and allowed to stand some time without charge or discharge, the electrolyte should be of low density, not over 1.210.

Several different methods may be adopted for controlling the discharge voltage and maintaining a uniform pressure at the lights, viz.: (1) by connecting in additional or "end" cells one at a time, as the voltage drops, by means of an end cell switch; (2) by a rheostat, whose resistance is cut out step by step; (3) by counter electro-motive force cells, which, like a rheostat, cut down the battery voltage at the beginning of discharge, and are cut out of circuit one by one by means of an end cell switch.

Also, several methods may be employed for obtaining the necessary increase of voltage for charging, viz.: (1) by dividing the battery into two equal parts and charging these in parallel through a suitable resistance, the generator running at normal (lamp) voltage; (2) by raising the voltage of the generator sufficiently to charge all the cells in one series; (3) by means of a booster, whose voltage is added to that of the generator, and is varied to give the total required.

In a lead storage-cell, if the surface and quantity of active material be accurately proportioned, and if the discharge be commenced immediately after the termination of the charge, then a current efficiency of as much as 98% may be obtained, provided the rate of discharge is low and well regulated. Since the current efficiency decreases as the discharge rate increases, and since very low discharge rates are seldom used in practice, efficiencies as high as this are never obtained practically, the average being about 90%.

After a battery has been erected and all connections made and the current ready, the electrolyte may be poured into the jars, and as soon thereafter as possible the initial charging should commence. Never allow a battery to stand longer than two hours after the acid is put in, before starting the charge. This should be as continuous as possible, until all cells gas freely and the specific gravity and voltage show no rise over a period of 10 hours. The duration of such a charge may vary from 30 to 100 hours, and is always given by the manufacturer. The temperature in any one cell should not be permitted to go above 100° F.; if this occurs, the charging rate must be reduced or the charge temporarily stopped.

The level of the electrolyte should be kept above the top of the plates by adding pure fresh water. Addition of new electrolyte is seldom necessary and should be done only on advice from the manufacturer.

The sediment which collects in the bottom of the cells should always be removed before it touches the plates.

The battery room should be well ventilated, especially when charging, and great care taken not to bring an exposed flame near the cells when charging or shortly after.

Metals or impurities of any kind must not be allowed to get into the cells. If this should happen, the impurity should be removed at once, and if badly contaminated, the electrolyte replaced with new. If in doubt as to the purity of electrolyte or water, the manufacturers should be consulted.

To take cells out of commission, the electrolyte should be drawn off; the cells filled with water and allowed to stand for 12 or 15 hours. The water can then be drawn off and the plates allowed to dry. When putting into service again, the same procedure should be followed as with the initial charge.

Lead storage batteries are extensively used for the following applications:

Stand-by service in central stations.

Voltage regulation on D. C. distribution lines.

To carry peak loads of central stations.

Voltage regulation in isolated building plants.

To carry load of isolated plant, when the plant is shut down for the night.

To furnish country places with power where such places are off the line of central stations.

To furnish current for talking circuits in telephone service.

To furnish current for signal work.

To light trains in connection with a generator system.

To operate submarine torpedo boats.

For ignition, starting and lighting on gas cars.

To propel electric pleasure and commercial vehicles.

To regulate long distance transmission lines.

For a complete treatise on lead storage batteries see Lyndon, "Storage Battery Engineering."

**Edison Alkaline Battery.**—The Edison storage battery is considerably lighter, although not as efficient as the lead battery, and for that reason it is extensively used for vehicle service. Its weight varies from 14 to 18 watt-hours per pound.

The active materials of this battery are oxides of nickel and iron in the positive and negative grids respectively, the electrolyte being a solution of caustic potash in water with a small amount of lithium hydrate. The first charging of a cell reduces the iron oxide to metallic iron while converting the nickel hydrate to a very high oxide of nickel, black in color. On discharge, the metallic iron goes back to iron oxide and the high nickel oxide goes to a lower oxide, but not to its original form of green nickel hydrate, and every cycle thereafter during charging the positive changes to a high nickel oxide. Current passing in either direction (charge or discharge) decomposes the potassium hydrate of the electrolyte and the oxidation and the reduction at the electrodes are brought about by the action of its elements. An amount of potassium hydrate equal to that decomposed is always reformed at one of the electrodes by a secondary chemical reaction, and consequently there is none of it lost and its density remains constant. The eventual results of charging, therefore, are a transference of oxygen from the iron to the nickel electrode and that of discharging is a transference back again.

The density of the electrolyte does not change during charge or discharge and consequently hydrometer readings are unnecessary.

To give the best output and efficiency, the manufacturer gives the normal rate of charge as 7 hours and discharge as 5 hours. The rates are, however, optional, and may with certain restrictions be based on the operating conditions. The discharge starts at 1.44 volts per cell, falls rapidly for the first hour, and slowly for 4 1/2 hours. The voltage at the end of 5 hours, the normal discharge period, is 1.11 per cell.

The charge starts at 1.54 volts per cell, rises rapidly for three-quarters of an hour, and then slowly until it becomes practically constant at the end of 7 hours. The voltage is then 1.81 per cell.

### ELECTROLYSIS.

Electrolysis is the separation of a chemical compound into its constituents by an electric current. Faraday gave the nomenclature of electrolysis. The compound to be decomposed is the electrolyte, and the process electrolysis. The plates or poles of the battery are electrodes. The plate where the greatest pressure exists is the anode, and the other pole is the cathode. The products of decomposition are ions.

Lord Rayleigh found that a current of one ampere will deposit 0.017253 grain, or 0.001118 gram of silver per second on one of the plates of a silver voltameter, the liquid employed being a solution of silver nitrate containing from 15% to 20% of the salt. The weight of hydrogen similarly set free by a current of one ampere is 0.00001038 gram per second.

Knowing the amount of hydrogen thus set free, and the chemical equivalents of the constituents of other substances, we can calculate what weight of their elements will be set free or deposited in a given time by a given current. Thus, the current that liberates 1 gram of hydrogen will liberate 8 grams of oxygen, or 107.7 grams of silver, the numbers 8 and 107.7 being the chemical equivalents for oxygen and silver respectively.

To find the weight of metal deposited by a given current in a given time, find the weight of hydrogen liberated by the given current in the given time, and multiply by the chemical equivalent of the metal.

The table below (from "Practical Electrical Engineering") is calculated upon Lord Rayleigh's determination of the electro-chemical equivalents and Roscoe's atomic weights.

## ELECTRO-CHEMICAL EQUIVALENTS.

Elements.	Valency.*	Atomic Weight.†	Chemical Equivalent.	Electro-chemical Equivalent (milligrams per coulomb).	Coulombs per gram.	Grams per ampere hour.
<b>ELECTRO-POSITIVE.</b>						
Hydrogen.....	H <sub>1</sub>	1.00	1.00	0.010384	96293.00	0.03738
Potassium.....	K <sub>1</sub>	39.04	39.04	0.40539	2467.50	1.45950
Sodium.....	Na <sub>1</sub>	22.99	22.99	0.23873	4188.90	0.85942
Aluminum.....	Al <sub>3</sub>	27.3	9.1	0.09449	1058.30	0.34018
Magnesium.....	Mg <sub>2</sub>	23.94	11.97	0.12430	804.03	0.44747
Gold.....	Au <sub>3</sub>	196.2	65.4	0.67911	1473.50	2.44480
Silver.....	Ag <sub>1</sub>	107.66	107.66	1.11800	894.41	4.02500
Copper (cupric).....	Cu <sub>2</sub>	63.00	31.5	0.32709	3058.60	1.17700
(cuprous).....	Cu <sub>1</sub>	63.00	63.00	0.65419	1525.30	2.35500
Mercury (mercuric).....	Hg <sub>2</sub>	199.8	99.9	1.03740	963.99	3.73450
(mercurous).....	Hg <sub>1</sub>	199.8	199.8	2.07470	481.99	7.46900
Tin (stannic).....	Sn <sub>4</sub>	117.8	29.45	0.30581	3270.00	1.10090
(stannous).....	Sn <sub>2</sub>	117.8	58.9	0.61162	1635.00	2.20180
Iron (ferric).....	Fe <sub>3</sub>	55.9	18.64‡	0.19356	5166.4	0.69681
(ferrous).....	Fe <sub>2</sub>	55.9	27.95	0.29035	3445.50	1.04480
Nickel.....	Ni <sub>2</sub>	58.6	29.3	0.30425	3286.80	1.09530
Zinc.....	Zn <sub>2</sub>	64.9	32.45	0.33696	2967.10	1.21330
Lead.....	Pb <sub>2</sub>	206.4	103.2	1.07160	933.26	3.85780
<b>ELECTRO-NEGATIVE.</b>						
Oxygen.....	O <sub>2</sub>	15.96	7.98	0.08286	.....	.....
Chlorine.....	Cl <sub>1</sub>	35.37	35.37	0.36728	.....	.....
Iodine.....	I <sub>1</sub>	126.53	126.53	1.31300	.....	.....
Bromine.....	Br <sub>1</sub>	79.75	79.75	0.82812	.....	.....
Nitrogen.....	N <sub>3</sub>	14.01	4.67	0.04849	.....	.....

\*Valency is the atom-fixing or atom-replacing power of an element compared with hydrogen, whose valency is unity.

†Atomic weight is the weight of one atom of each element compared with hydrogen, whose atomic weight is unity.

‡Becquerel's extension of Faraday's law showed that the electro-chemical equivalent of an element is proportional to its chemical equivalent. The latter is equal to its combining weight, and not to atomic weight ÷ valency, as defined by Thompson, Hospitalier, and others who have copied their tables. For example, the ferric salt is an exception to Thompson's rule, as are sesqui-salts in general.

Thus: Weight of silver deposited in 10 seconds by a current of 10 amperes = weight of hydrogen liberated per second × number of seconds × current strength × 107.7 = 0.00001038 × 10 × 10 × 107.7 = 0.1178 gram.

Weight of copper deposited in 1 hour by a current of 10 amperes =

$$0.00001038 \times 3600 \times 10 \times 31.5 = 11.77 \text{ grams.}$$

Since 1 ampere per second liberates 0.00001038 gram of hydrogen, strength of current in amperes

$$= \text{weight in grams of H liberated per second} \div 0.00001038$$

$$= \frac{\text{weight of element liberated per second}}{0.00001038 \times \text{chemical equivalent of element}}$$



### THE MAGNETIC CIRCUIT.

For units of the magnetic circuit, see page 1398.

**Lines and Loops of Force.** — It is conventionally assumed that the attractions and repulsions shown by the action of a magnet or a conductor upon iron filings are due to "lines of force" surrounding the magnet or conductor. The "number of lines" indicates the magnitude of the forces acting. As the iron filings arrange themselves in concentric circles, we may assume that the forces may be represented by closed curves or "loops of force." The following assumptions are made concerning the loops of force in a conductive circuit:

1. That the lines or loops of force in the conductor are parallel to the axis of the conductor.

2. That the loops of force external to the conductor are proportional in number to the current in the conductor, that is, a definite current generates a definite number of loops of force. These may be stated as the strength of field in proportion to the current.

3. That the radii of the loops of force are at right angles to the axis of the conductor.

The magnetic force proceeding from a point is equal at all points on the surface of an imaginary sphere described by a given radius about that point. A sphere of radius 1 cm. has a surface of  $4\pi$  square centimeters. If  $\phi$  = total flux, expressed as the number of lines of force emanating from a magnetic pole having a strength  $M$ ,

$$\phi = 4\pi M; M = \phi \div 4\pi.$$

Magnetic moment of a magnet = product of strength of pole  $M$  and its length, or distance between its poles  $L$ . Magnetic moment =  $\phi L \div 4\pi$ .

If  $B$  = number of lines flowing through each square centimeter of cross-section of a bar-magnet, or the "specific induction," and  $A$  = cross-section

$$\text{Magnetic Moment} = LAB \div 4\pi.$$

If the bar-magnet be suspended in a magnetic field of density  $H$  and so placed that the lines of the field are all horizontal and at right angles to the axis of the bar, the north pole will be pulled forward, that is, in the direction in which the lines flow, and the south pole will be pulled in the opposite direction, the two forces producing a torsional moment or torque,

$$\text{Torque} = MLH = LABH \div 4\pi, \text{ in dyne-centimeters.}$$

Magnetic attraction or repulsion emanating from a point varies inversely as the square of the distance from that point. The law of inverse squares, however, is not true when the magnetism proceeds from a surface of appreciable extent, and the distances are small, as in dynamo-electric machines and ordinary electromagnets.

**The Magnetic Circuit.** — In the electric circuit

$$\text{Current} = \frac{\text{E.M.F.}}{\text{Resistance}}, \text{ or } I = \frac{E}{R}; \text{ Amperes} = \frac{\text{volts}}{\text{ohms}}$$

Similarly, in the magnetic circuit

$$\text{Flux} = \frac{\text{Magnetomotive Force}}{\text{Reluctance}}, \text{ or } \phi = \frac{F}{R}. \quad \text{Maxwells} = \frac{\text{Gilberts}}{\text{Oersteds}}.$$

Reluctance is the reciprocal of permeance, and permeance is equal to permeability  $\times$  path area  $\div$  path length (metric measure); hence

$$\phi = F\mu a \div l.$$

One ampere-turn produces 1.257 gilberts of magnetomotive force and one inch equals 2.54 centimeters; hence, in inch measure,

$$\phi = (1.257A_t) \mu 6.45 a \div 2.54 l = 3.192 \mu a A_t \div l.$$

The ampere-turns required to produce a given magnetic flux in a given path will be

$$A_t = \phi l \div 3.192 \mu a = 0.3133 \phi l \div \mu a.$$

Since magnetic flux  $\div$  area of path = magnetic density, the ampere-turn required to produce a density  $B$ , in lines of force per square inch of area of path, will be

$$A_t = 0.3133 Bl \div \mu.$$

This formula is used in practical work, as the magnetic density must be predetermined in order to ascertain the permeability of the material under its working conditions. When a magnetic circuit includes several qualities of material, such as wrought iron, cast iron, and air, it is most direct to work in terms of ampere-turns per unit length of path. The

ampere-turns for each material are determined separately, and the winding is designed to produce the sum of all the ampere-turns. The following table gives the average results from a number of tests made by Dr. Samuel Sheldon:

VALUES OF B AND H

H	Ampere-turns per centimeter length.	Ampere-turns per inch length.	Cast Iron.		Cast Steel.		Wrought Iron.		Sheet Metal.	
			B Kilo-gausses.	Kilomax-wells per sq. in.	B Kilo-gausses.	Kilomax-wells per sq. in.	B Kilo-gausses.	Kilomax-wells per sq. in.	B Kilo-gausses.	Kilomax-wells per sq. in.
10	7.95	20.2	4.3	27.7	11.5	74.2	13.0	83.8	14.3	92.2
20	15.90	40.4	5.7	36.8	13.8	89.0	14.7	94.8	15.6	100.7
30	23.85	60.6	6.5	41.9	14.9	96.1	15.3	98.6	16.2	104.5
40	31.80	80.8	7.1	45.8	15.5	100.0	15.7	101.2	16.6	107.1
50	39.75	101.0	7.6	49.0	16.0	103.2	16.0	103.2	16.9	109.0
60	47.70	121.2	8.0	51.6	16.5	106.5	16.3	105.2	17.3	111.6
70	55.65	141.4	8.4	59.2	16.9	109.0	16.5	106.5	17.5	112.9
80	63.65	161.6	8.7	56.1	17.2	111.0	16.7	107.8	17.7	114.1
90	71.60	181.8	9.0	58.0	17.4	112.2	16.9	109.0	18.0	116.1
100	79.50	202.0	9.4	60.6	17.7	114.1	17.2	110.9	18.2	117.3
150	119.25	303.0	10.6	68.3	18.5	119.2	18.0	116.1	19.0	122.7
200	159.0	404.0	11.7	75.5	19.2	123.9	18.7	120.8	1.96	126.5
250	198.8	505.0	12.4	80.0	19.7	127.1	19.2	123.9	20.2	130.2
300	238.5	606.0	13.2	85.1	20.1	129.6	19.7	127.1	20.7	133.5

H = 1.257 ampere-turns per cm. = 0.495 ampere-turns per inch.

EXAMPLE.— A magnetic circuit consists of 12 ins. of cast steel of 8 sq. ins. cross-section; 4 ins. of cast iron of 22 sq. ins. cross-section; 3 ins. of sheet iron of 8 sq. ins. cross-section; and two air-gaps each  $\frac{1}{16}$  in. long and of 12 sq. ins. area. Required, the ampere-turns to produce a flux of 768,000 maxwells, which is to be uniform throughout the magnetic circuit.

The flux density in the steel is  $768,000 \div 8 = 96,000$  maxwells; the ampere-turns per inch of length, according to Sheldon's table, are 60.6, so that the 12 in. of steel will require 727.2 ampere-turns.

The density in the cast iron is  $768,000 \div 22 = 34,900$ ; the ampere-turns =  $4 \times 40 = 160$ .

The density in the sheet iron =  $768,000 \div 8 = 96,000$ ; ampere-turns per inch = 30; total ampere-turns for sheet iron = 90.

The air-gap density is  $768,000 \div 12 = 64,000$ ; ampere-turns per in. =  $0.3133B$ ; ampere-turns required for air-gap =  $0.3133 \times 64,000 \div 8 = 2506.4$ .

The entire circuit will require  $727.2 + 160 + 90 + 2506.4 = 3483.6$  ampere-turns, assuming uniform flux throughout.

In practice there is considerable "leakage" of magnetic lines of force; that is, many of the lines stray away from the useful path, there being no material opaque to magnetism and therefore no means of restricting it to a given path. The amount of leakage is proportional to the permeance of the leakage paths available between two points in a magnetic circuit which are at different magnetic potentials, such as opposite ends of a magnet coil. It is seldom practicable to predetermine with any approach to accuracy the magnetic leakage that will occur under given conditions unless one has profuse data obtained experimentally under similar conditions. In dynamo-electric machines the leakage coefficient varies from 1.3 to 2.

**Tractive or Lifting Force of a Magnet.** — The lifting power or "pull" exerted by an electro-magnet upon an armature in actual contact with its pole-faces is given by the formula

$$\text{Lbs.} = B^2 a \div 72,134,000,$$

a being the area of contact in square inches and B the magnetic density over this area. If the armature is very close to the pole-faces this formula also applies with sufficient accuracy for all practical purposes, but a considerable air-gap renders it inapplicable.

The design of solenoids for the coil-and-plunger type of electro-magnets

is described by C. R. Underhill in his book, "Solenoids, Electro-Magnets, and Electro-Magnetic Windings."

Various forms of magnetic chucks are illustrated and described by O. S. Walker, in *Am. Mach.*, Feb. 11, 1909.

For magnets used in hoisting, see page 1193.

**Determining the Polarity of Electro-Magnets.**—If a wire is wound around a magnet in a right-handed helix, the end at which the current flows into the helix is the south pole. If a wire is wound around an ordinary wood-screw, and the current flows around the helix in the direction from the head of the screw to the point, the head of the screw is the south pole. If a magnet is held so that the south pole is opposite the eye of the observer, the wire being wound a right-handed helix around it, the current flows in a right-handed direction, with the hands of a clock.

**Determining the Direction of a Current.**—Place a wire carrying a current above and parallel to a pivoted magnetic needle. If the current be flowing along the wire from N. to S., it will cause the N.-seeking pole to turn to the eastward; if it be flowing from S. to N., the pole will turn to the westward. If the wire be below the needle, these motions will be reversed.

Maxwell's rule. The direction of the current and that of the resisting magnetic force are related to each other as are the rotation and the forward travel of an ordinary (right-handed) corkscrew.

### DYNAMO-ELECTRIC MACHINES.

A dynamo-electric machine is a machine for converting mechanical energy into electrical energy, or *vice versa*. It may be either a direct current or an alternating current machine.

**Rating.**—The *A. I. E. E. Standardization Rules* (1914) recommend that in the case of Direct Current Generators, the rating shall be expressed in Kilowatts (Kw.) available at the terminals.

In the case of Alternators and Transformers, the rating shall be expressed in kilovolt-amperes (Kv.-a.) available at the terminals, at a specified power factor. The corresponding kilowatts should also preferably be stated.

In the case of Motors, it is recommended that the rating shall be expressed in kilowatts (Kw.) available at the shaft. Since the input of machinery of this class is measured in electrical units and since the output has a definite relation to the input, it is logical to measure the delivered power in the same units as are employed for the receiving power. However, on account of the prevailing practice of expressing mechanical output in horse-power, it is recommended that for machinery of this class the rating should, for the present, be expressed both in kilowatts and in horse-power; as follows:

Kw. ————— approx. equiv. h.p. —————

The horse-power rating of a motor may, for practical purposes, be taken as  $\frac{4}{3}$  of the kilowatt rating.

There are various kinds of ratings, such as:

**Continuous Rating.**—A machine rated for continuous service shall be able to operate continuously at its rated output, without exceeding any of the limitations specified.

**Short-Time Rating.**—A machine rated for short-time service (*i.e.*, service including runs alternating with stoppages of sufficient duration to ensure substantial cooling) shall be able to operate at its rated output during a limited period, to be specified in each case, without exceeding any of the limitations specified.

**Nominal Ratings.**—For railway motors and railway sub-station machinery, certain nominal ratings are employed.

**Duty-Cycle Operation.**—Many machines are operated on a cycle of duty which repeats itself with more or less regularity. For purposes of rating, either a continuous or a "short-time" "equivalent load" may be selected which shall simulate as nearly as possible the thermal conditions of the actual duty cycle.

Standard durations of equivalent tests shall be for machines operating under specified duty-cycles: 5 min., 10 min., 30 min., 60 min.



120 min., and continuous. Of these the first 5 are short-time ratings selected as being thermally equivalent to the specified duty cycle. When, for example, a short-time rating of 10 minutes' duration is adopted, and the thermally equivalent load is 25 kw. for that period, then such a machine shall be stated to have a 10-minute rating of 25 kw. In every case the equivalent short-time test shall commence only when the windings and other parts of the machine are within 5° C. of the ambient temperature at the time of starting the test. In the absence of any specification as to the kind of rating, the continuous rating shall be understood.

**Temperature Limitations of the Capacity of Electrical Machinery.**—

The capacity, so far as relates to temperature, is usually limited by the maximum temperature at which the materials in the machine, especially those employed for insulation, may be operated for long periods without deterioration. When the safe limits are exceeded, deterioration is rapid. The insulating material becomes permanently damaged by excessive temperature, the damage increasing with the length of time that the excessive temperature is maintained, and with the amount of excess temperature, until finally the insulation breaks down.

*Ambient Temperature of Reference for Air.*—The standard ambient temperature of reference, when the cooling medium is air, shall be 40° C. (104° F.).

The permissible rises in temperature given in column 2 of the table on p. 1434 have been calculated on the basis of the standard ambient temperature of reference, by subtracting 40° C. from the highest temperatures permissible, which are given in column 1 of the same table.

*Altitude.*—Increased altitude has the effect of increasing the temperature rise of some types of machinery. In the absence of information in regard to the height above sea level at which the machine is intended to work in ordinary service, this height is assumed not to exceed 1000 meters (3300 feet). For machinery operating at an altitude of 1000 meters or less, a test at any altitude less than 1000 meters is satisfactory, and no correction shall be applied to the observed temperatures. Machines intended for operation at higher altitudes shall be regarded as special. When a machine is intended for service at altitudes above 1000 meters (3300 feet) the permissible temperature rise at sea level, until more nearly accurate information is available, shall be reduced by 1 per cent for each 100 meters (130 ft.) by which the altitude exceeds 1000 meters. Water-cooled oil transformers are exempt from this reduction.

*Ambient Temperature of Reference for Water-Cooled Machinery.*—For water-cooled machinery, the standard temperature of reference for incoming cooling water shall be 25° C. (77° F.), measured at the intake of the machine.

*Corrections for the Deviation of the Ambient Temperature, at the time of test, from the reference value of 40° C.*—The effect on the temperature rise of the precise value of the ambient temperature at the time of test is small, obscure, and of doubtful direction. No correction shall be made for ambient temperature deviations from the standard value of 40° C. It is desirable, however, that tests should be conducted at ambient temperatures not lower than 25° C. Exception to this rule is made in the case of air-blast transformers, in which, if the incoming air temperature during the test differs from 40° C., a correction on account of difference in resistance and difference in convection shall be made by changing the "observable" temperature rise of the windings by 0.5 per cent for each degree centigrade. Thus with a room temperature of 30° C. the "observable" rise of temperature shall be increased by 5 per cent, and with a room temperature of 15° C. the "observable" rise of temperature shall be increased by 12.5 per cent.

The actual temperatures attained in the different parts of a machine, and not the rises in temperature, affect the life of the insulation of the machine. The temperatures in the different parts of a machine which it is desired to ascertain, are the maximum temperatures reached in those parts.

As it is usually impossible to determine the maximum temperature attained in insulated windings, it is convenient to apply a correction to the observable temperature, to approximate the difference between the actual maximum temperature and the observable temperature by

the method used. This correction or margin of security is provided to cover the errors due to fallibility in the location of the measuring devices, as well as inherent inaccuracies in measurement and methods.

**Methods of Determining the Temperature of Different Parts of a Machine.**—Three methods will be considered. One or other of these methods will usually be appropriate for commercial measurements on any particular type of machine.

*No. 1. Thermometer Method.*—This method consists in the determination of the temperature by mercury or alcohol thermometers, by resistance thermometers, or by thermo-couples, applied to the hottest accessible part of the completed machine, as distinguished from the thermo-couples or resistance coils imbedded in the machine as described under Method No. 3. When Method No. 1 is used, the hottest-spot temperature for windings shall be estimated by adding a hottest-spot correction of 15° C. to the highest temperature observed, in order to allow for the impossibility of locating any of the thermometers at the hottest spot.

Exception. In cases where the thermometer is applied directly to the surfaces of a bare winding, such as an edgewise strip conductor, or a cast copper winding, a hottest-spot correction of 5° C. instead of 15° C. shall be made. For bare metallic surfaces not forming part of a winding, no correction is to be applied.

*No. 2. Resistance Method.* This method consists in the measurement of the temperature of windings by their increase in resistance, corrected to the instant of shut-down when necessary. In the application of this method thermometer measurements must also be made whenever practicable without disassembling the machine, in order to increase the probability of revealing the highest observable temperature. Whichever method yields the higher temperature, that temperature shall be taken as the "highest observable" temperature and a hottest-spot correction of 10° C. added thereto.

In the case of resistance measurements, the temperature coefficient of copper shall be deduced from the formula  $1/(234.5 + t)$ . Thus, at an initial temperature  $t = 40^\circ \text{C.}$ , the temperature coefficient or increase in resistance per degree centigrade rise is  $1/(274.5) = 0.00364$ .

*No. 3. Imbedded Temperature-Detector Method.* Thermo-couples or resistance coils, located as nearly as possible at the estimated hottest spot. This method is only to be used with coils placed in slots.

**Temperature Limits.**—In the following table column 1 gives the permissible limits for the hottest-spot temperatures of insulations, and column 2 the highest permissible temperature rise of the hottest spot above 40° C. permitted under rated-load conditions, for the purpose of fixing the Institute rating. The rise of temperature observed must never exceed the limits in column 2 of the table. The highest temperatures attained in any machine corresponding to the output for which it is rated must not exceed the values indicated in column 1 of the table and the clauses following:

### Hottest-Spot Temperatures and Corresponding Permissible Temperature Rises.

Class.	Insulation.	Col. 1.	Col. 2.
A 1	Cotton, silk, paper, and other fibrous materials, not so treated as to increase the thermal limit . . . . .	95° C.	55° C.
A 2	Similar to A 1, but treated or impregnated and including enameled wire . . . . .	105° C.	65° C.
B	Mica, asbestos, or other material capable of resisting high temperatures, in which any Class A material or binder, if used, is for structural purposes only, and may be destroyed without impairing the insulating or mechanical qualities . . . . .	125° C.	85° C.
C	Fireproof and refractory materials . . . . .	No limit specified.	

**Summary of the Temperature Conditions under the Three Methods of Measurement for Insulations of Classes A<sub>1</sub>, A<sub>2</sub>, and B.**

Class.	Hottest Spot Temp.	Imbedded Thermo-couples or Resistance Coils.										
		Thermometer only.		Resistance.*		Double-layer Windings. All voltages.		Single-layer Windings. 5000 volts or less.		Single-layer Windings above 5000 volts.		
		a	b	a	b	a	b	a	b	Hottest Spot Correction.	Limiting Observable Temperature	Limiting Observable Temp. Rise above 40°.
A <sub>1</sub>	95°	15	80	10	85	5	90	10	85	10+(E-5)†	85 - (E-5)	45 - (E-5)
A <sub>2</sub>	105°	15	90	10	95	5	100	10	95	10+(E-5)	95 - (E-5)	55 - (E-5)
B	125°	15	110	10	115	5	120	10	115	10+(E-5)	115 - (E-5)	75 - (E-5)

\* With thermometer check when practicable.

a Hottest-spot correction. b Limiting observable temperature.

The limit of the observable temperature rise above 40° always = (b - 40°).

† In this formula E represents the rated pressure between terminals in kilovolts. Thus for a three-phase machine with single-layer winding of 11 kilovolts between terminals, the hottest spot correction to be added to the maximum observable temperature will be 16° C.

**Special Cases of Temperature Limits. — Temperature of Oil.**

The oil in which apparatus is immersed shall in no part have an observable temperature in excess of 90° C.

**Water-cooled Transformers.** The hottest-spot temperature shall not exceed 85° C.

**Commutators.** The observable temperature shall in no case be permitted to exceed the values given in the table for the insulation employed, either in the commutator or in any insulation whose temperature would be affected by the heat of the commutator.

For commutators so constructed that no difficulties from expansion can occur, the following temperature limits are suggested:

**Current per Brush Arm.**

- 200 amperes or less.
- 200 to 900 amperes.

**Maximum Permissible Temp.**

- 130° C.
- 130° C. less 5 deg. for each 100 amperes increase above 200.
- 95° C.

900 amperes and over.

**Moving Force of a Dynamo-electric Machine. —** A wire through which a current passes has, when placed in a magnetic field, a tendency to move perpendicular to itself and at right angles to the lines of the field. The force producing this tendency is  $P = lBI$  dynes, in which  $l$  = length of the wire,  $I$  = the current in C.G.S. units, and  $B$  = the induction, or flux density, in the field in gausses or lines per square centimeter.

If the current  $I$  is taken in amperes,  $P = lBI \div 10 = lBI \times 10^{-1}$ .

If  $P_k$  is taken in kilograms,

$$P_k = lBI \div 9,810,000 = 10.1937 lBI \times 10^{-8} \text{ kilograms.}$$

**EXAMPLE.**—The mean strength of field,  $B$ , of a dynamo is 5000 C.G.S. lines; a current of 100 amperes flows through a wire; the force acts upon 10 centimeters of the wire =  $10.1937 \times 10 \times 100 \times 5000 \times 10^{-8} = 0.5097$  kilograms.

**Torque of an Armature. —** The torque of an armature is the moment tending to turn it. In a generator it is the moment which must be applied to the armature to turn it in order to produce current. In a motor it is the turning moment which the armature gives to the pulley.



Let  $I$  = current in the armature in amperes,  $E$  = the electromotive force in volts,  $T$  = the torque in pound-feet,  $\phi$  = the flux through the armature in maxwells,  $N$  = the number of conductors around the armature, and  $n$  = the number of revolutions per second. Then

$$\text{Watts} = IE = 2\pi nT \times 1.356.*$$

In any machine if the flux be constant,  $E$  is directly proportional to the speed and  $= \phi N n \div 10^8$ ; whence

$$\phi NI \div 10^8 = 2\pi T \times 1.356;$$

$$T = \frac{\phi NI}{10^8 \times 2\pi \times 1.356} = \frac{\phi NI}{8.52 \times 10^8} \text{ pound-feet.}$$

Let  $l$  = length of armature in inches,  $d$  = diameter of armature in inches,  $B$  = flux density in maxwells per square inch, and let  $m$  = the ratio of the conductors under the influence of the pole-pieces to the whole number of conductors on the armature. Then

$$\phi = \frac{1}{2}\pi d \times l \times B \times m.$$

These formulæ apply to both generators and motors. They show that torque is independent of the speed and varies directly with the current and the flux. The total peripheral force is obtained by dividing the torque by the radius (in feet) of the armature, and the drag on each conductor is obtained by dividing the total peripheral force by the number of conductors under the influence of the pole-pieces at one time.

EXAMPLE.—Given an armature of length  $l = 20$  inches, diameter  $d = 12$  inches, number of conductors  $N = 120$ , of which 80 are under the influence of the pole-pieces at one time; let the flux density  $B = 30,000$  maxwells per sq. in. and the current  $I = 400$  amperes.

$$\phi = \frac{12\pi}{2} \times 20 \times 30,000 \times \frac{80}{120} = 7,540,000.$$

$$T = \frac{7,540,000 \times 120 \times 400}{8.52 \times 100,000,000} = 424.8 \text{ pound-feet.}$$

Total peripheral force =  $424.8 \div 0.5 = 849.6$  lbs.

Drag per conductor =  $849.6 \div 120 = 7.08$  lbs.

The work done in one revolution = torque  $\times$  circumference of a circle of 1 foot radius =  $424.8 \times 6.28 = 2670$  foot-pounds.

Let the revolutions per minute equal 500, then the horse-power

$$= \frac{2670 \times 500}{33000} = 40.5 \text{ H.P.}$$

**Torque, Horse-power and Revolutions.** —  $T$  = torque in pound-feet, H.P. =  $T \times \text{Rpm.} \times 6.2832 \div 33,000 = IE \div 746$ . Whence Torque =  $7.0403 EI \div \text{Rpm.}$  or 7 times the watts  $\div$  the revs. per min. nearly.

**Electromotive Force of the Armature Circuit.** — From the horse-power, calculated as above, together with the amperes, we can obtain the E.M.F. for  $IE = \text{H.P.} \times 746$ , whence E.M.F. or  $E = \text{H.P.} \times 746 \div I$ .

If H.P., as above, = 40.5, and  $I = 400$ ,  $E = \frac{40.5 \times 746}{400} = 75.5$  volts.

The E.M.F. may also be calculated by the following formulæ:

$I$  = Total current through armature;

$e_a$  = E.M.F. in armature in volts;

$N$  = Number of active conductors counted all around armature;

$p$  = Number of pairs of poles ( $p = 1$  in a two-pole machine);

$n$  = Speed in revolutions per minute;

$\phi$  = Total flux in maxwells.

$$\text{Electromotive force:} \quad \begin{cases} e_a = \phi N \frac{n}{60} 10^{-8} \text{ for two-pole machines.} \\ e_a = \frac{p\phi N}{10^8} \frac{n}{60} \text{ for multipolar machines with series-wound armature} \end{cases}$$

**Strength of the Magnetic Field.** — Let  $I$  = current in amperes,  $N$  = number of turns in the coil.  $A$  = area of the cross-section of the core in

\* 1 ft.-lb. per second = 1.356 watts.

square centimeters,  $l$  = length of core in centimeters,  $\mu$  the permeability of the core, and  $\phi$  = flux in maxwells. Then

$$\phi = \frac{\text{Magnetomotive Force}}{\text{Reluctance}} = \frac{1.257 NI}{(l + A\mu)}$$

In a dynamo-electric machine the reluctance will be made up of three separate quantities, viz.: that of the field magnet cores, that of the air spaces between the field magnet pole-pieces and the armature, and that of the armature. The total reluctance is the sum of the three. Let  $L_1$ ,  $L_2$ ,  $L_3$  be the length of the path of magnetic lines in the field magnet cores,\* in the air-gaps, and in the armature respectively; and let  $A_1$ ,  $A_2$ ,  $A_3$  be the areas of the cross-sections perpendicular to the path of the magnetic lines in the field magnet cores, the air-gaps, and the armature respectively. Let the permeability of the field magnet cores be  $\mu_1$ , and of the armature  $\mu_3$ . The permeability of the air-gaps is taken as unity. Then the total reluctance of the machine will be

$$\frac{L_1}{A_1\mu_1} + \frac{L_2}{A_2} + \frac{L_3}{A_3\mu_3}$$

$$\text{The flux, } \phi = \frac{1.257 NI}{(L_1 \div A_1\mu_1) + (L_2 \div A_2) + (L_3 \div A_3\mu_3)}$$

The ampere-turns necessary to create a given flux in a machine may be found by the formula,

$$NI = \phi \frac{[(L_1 \div A_1\mu_1) + (L_2 \div A_2) + (L_3 \div A_3\mu_3)]}{1.257}$$

But the total flux generated by the field coils is not available to produce current in the armature. There is a leakage between the field magnets, and this must be allowed for in calculations. The leakage coefficient varies from 1.3 to 2 in different machines. The meaning of the coefficient is that if a flux of say 100 maxwells per square cm. are desired in the field coils, it will be necessary to provide ampere turns for  $1.3 \times 100 = 130$  maxwells, if the leakage coefficient be 1.3.

Another method of calculating the ampere-turns necessary to produce a given flux is to calculate the magnetomotive force required in each portion of the machine, separately, introducing the leakage coefficient in the calculation for the field magnets, and dividing the sum of the magnetomotive forces by 1.257.

In the ordinary type of multipolar machine there are as many magnetic circuits as there are poles. Each winding energizes part of two circuits. The calculation is made in the same manner as for a single magnetic circuit.

### DIRECT-CURRENT GENERATORS.

Direct-current generators may be separately excited, in which case the field magnets are excited or magnetized from some external source, as, for instance, a storage battery or another continuous-current dynamo. Such generators are used to some extent in connection with regulating sets, but as a rule almost all direct-current generators are self-excited, in which case the magnetizing current for the field-coils is furnished by the dynamo itself.

Direct-current generators (as well as motors) may be classified according to the manner of the field-winding into:

1. *Series-wound Dynamo.*—The field-winding and the external circuit are connected in series with the armature-winding, so that the entire armature current must pass through the field-coils.

Since in a series-wound dynamo the armature-coils, the field, and the external circuit are in series, any increase in the resistance of the external circuit will decrease the electro-motive force from the decrease in the magnetizing currents. A decrease in the resistance of the external cir-

---

\* The length of the path in the field-magnet cores  $L_1$  includes that portion of the path which lies in the piece joining the cores of the various field-magnets.

cuit will, in a like manner, increase the electro-motive force from the increase in the magnetizing current. The use of a regulator avoids these changes in the electro-motive force.

2. *Shunt-wound Dynamo.*—The field-magnet coils are placed in a shunt to the armature circuit, so that only a portion of the current generated passes through the field-magnet coils, but all the difference of potential of the armature acts at the terminals of the field-circuit.

In a shunt-wound dynamo an increase in the resistance of the external circuit increases the electro-motive force, and a decrease in the resistance of the external circuit decreases the electro-motive force. This is just the reverse of the series-wound dynamo.

In a shunt-wound dynamo a continuous balancing of the current occurs, the current dividing at the brushes between the field and the external circuit in the inverse proportion to the resistance of these circuits. If the resistance of the external circuit becomes greater, a proportionately greater current passes through the field magnets, and so causes the electro-motive force to become greater. If, on the contrary, the resistance of the external circuit decreases, less current passes through the field, and the electro-motive force is proportionately decreased.

3. *Compound-wound Dynamo.*—The field magnets are wound with two separate sets of coils, one of which is in series with the armature and the external circuit, and the other in shunt with the armature or the external circuit.

A compound generator is made for the purpose of delivering current at constant potential either at the terminals of the machine or at some distant receiving point on the line. In the former case the machine is flat-compounded, the ideal being the same terminal voltage at full load as at no load, giving a practically horizontal voltage characteristic. In the latter case the machine is over-compounded, giving a terminal voltage which rises from no load to full load to compensate for line drop, so that at the receiving end of the line the voltage will be constant at all loads.

The standard voltages for ordinary light and power service are 125 and 250 volts, while for railway service they have been built for voltages as high as 1200, and in one particular installation two such machines are connected in series furnishing a supply voltage of 2400 volts.

Many direct-current generators are provided with commutating poles, and such machines may be operated over an extremely wide range of load and voltage with fixed brush positions and sparkless commutation. The commutating winding produces a magnetic field which is in a direction to assist the reversal of current in the coil undergoing commutation and also directly opposed to the field generated by armature reaction which tends to retard the reversal of current in this coil. The commutating field thus completely nullifies the distortive effect of armature reaction on the main field flux in the commutating zone, and generates an e.m.f. which helps the brush to commute the current without sparking, and with a consequent increased life of the commutator and brushes.

Commutating poles are placed between the main poles of direct-current generators and motors. They are used for the purpose of nullifying the effect of the armature reaction upon the magnetic field adjacent to the neutral point. The armature reaction tends to move the neutral point from its proper mechanical position, and it is obvious that a number of ampere turns setting up magnetic lines of force equal to and opposing the directions of those set up by the armature ampere turns will nullify that effect on the neutral occasioned by the armature reaction.

The commutating pole winding is connected in series with the armature and has a number of turns per pole sufficient to give a magnetic strength that will not only counteract the armature reaction above referred to, but will actually reverse the current in the coil when it is in the commutating zone.

The commutating zone is the region over which the brushes may have to be moved in order to obtain good commutation between no load and full load. With commutating pole machines no such movement is necessary and the reversal takes place in the coils short circuited under the brushes.



Inasmuch as the commutating windings are directly in series with the armature, their strength varies directly with the armature current and provides the correct rectifying effect for proper reversal of current in the coils at all loads. Hence it is unnecessary to shift the brushes as the load changes.

**Parallel Operation.**—The first requisite for satisfactory parallel operation of direct current generators is that they have the same characteristics. They must have the same degree of compounding for any percentage of their rated load. The resistance of series fields with their shunt resistances and cable connections to the bus-bar should furthermore be inversely proportional to the capacities of the machines; *i.e.*, no matter what size cables are used, the resistances of the two connections must be so proportioned that the drop will be the same for both machines between the equalizer junction and the main bus-bar when each machine is delivering its full-load current.

**Three-Wire System.**—The chief advantage of the Edison three-wire system over the ordinary two-wire installation is that of economy in distribution. In a two-wire system with a given load and a given percentage of voltage drop, the distribution at 250 volts requires only one-quarter the weight of copper required for a distribution at 125 volts. A neutral wire in the three-wire system will, however, modify this proportion of copper, the final saving depending on the size of the neutral. In well-designed systems, the maximum unbalanced current carried by the neutral will be about 25 per cent of the full load. Therefore the size of the neutral need not be larger than 25 per cent of the capacity of the outside mains, and the weight of the copper in this case would be  $\frac{9}{32}$  of that used in distributing the same power by a two-wire system.

The practical methods available for operating direct-current three-wire systems are: 1. Two generators. 2. One generator with balancer set. 3. One generator with storage battery. 4. One generator with balancing coil. 5. Three-wire generator.

## ALTERNATING CURRENTS.\*

The advantages of alternating over direct currents are: 1. Greater simplicity of dynamos and motors, no commutators being required; 2. The feasibility of obtaining high voltages, by means of static transformers, for cheapening the cost of transmission; 3. The facility of transforming from one voltage to another, either higher or lower, for different purposes.

A direct current is uniform in strength and direction, while an alternating current rapidly rises from zero to a maximum, falls to zero, reverses its direction, attains a maximum in the new direction, and again returns to zero. This series of changes can best be represented by a curve the abscissas of which represent time and the ordinates either current or electro-motive force (*e.m.f.*). The curve usually chosen for this purpose is the sine curve, Fig. 228; the best forms of alternators give a curve that is a very close approximation to the sine curve, and all calculations and deductions of formulæ are based on it. The equation of the sine curve is  $y = \sin x$ , in which  $y$  is any ordinate, and  $x$  is the angle passed over by a moving radius vector.

After the flow of a direct current has been once established, the only opposition to the flow is the resistance offered by the conductor to the passage of current through it. This resistance of the conductor, in treating of alternating currents, is sometimes spoken of as *ohmic resistance*. The word resistance, used alone, always means the ohmic resistance. In alternating currents, in addition to the resistance, sev-

---

\* Only a very brief treatment of the subject of alternating currents can be given in this book. The following works are recommended as valuable for reference: Steinmetz, "Theoretical Elements of Electrical Engineering. Alternating Current Phenomena"; Cohen, "Formulæ and Tables for the Calculation of Alternating Current Problems"; Jackson, "Alternating Currents and Alternating Current Machinery"; Bedell, "Direct and Alternating Current Manual"; Timbie, "Alternating Currents."

eral other quantities, which affect the flow of current, must be taken into consideration. These quantities are inductance, capacity, and skin effect. They are discussed under separate headings.

The current and the e.m.f. may be in phase with each other, that is, they may attain their maximum strength at the same instant, or they may not, depending on the character of the circuit. In a circuit containing only resistance, the current and e.m.f. are in phase; in a circuit containing inductance the e.m.f. attains its maximum value before the current, or leads the current. In a circuit containing capacity the current leads the e.m.f. If both capacity and inductance are present in a circuit, they will tend to neutralize each other.

**Maximum, Average, and Effective Values.**—The strength and the e.m.f. of an alternating current being constantly varied, the maximum value of either is attained only for an instant in each period. The maximum values are little used in calculations, except in deducing formulæ and for proportioning insulation, which must stand the maximum pressure. The average value is obtained by averaging the ordinates of the sine curve representing the current, and is  $2 \div \pi$  or 0.637 of the maximum value.

The value of greatest importance is the effective, or "square root of the mean square," value. It is obtained by taking the square root of the mean of the squares of the ordinates of the sine curve. The effective value is the value shown on alternating-current measuring instruments. The product of the square of the effective value of the current and the resistance of the circuit is the heat lost in the circuit.

The relation of the maximum, average, and effective values is:

$$E_{\text{Effec.}} = E_{\text{Max.}} \times 0.707; \quad E_{\text{Aver.}} = E_{\text{Max.}} \times 0.637; \quad E_{\text{Max.}} = 1.41 \times E_{\text{Effec.}}$$

**Frequency.**—The time required for an alternating current to pass through one complete cycle, as from one maximum point to the next (*a* and *b*, Fig. 228), is termed the period. The number of periods in a second is termed the frequency of the current. Since the current changes its direction twice in each period, the number of reversals or alternations is double the frequency. A current of 120 alternations per second has a period of  $1/60$  and a frequency of 60. The frequency of a current is equal to one-half the number of poles on the generator, multiplied by the number of revolutions per second. Frequency is denoted by the letter *f*.

The frequencies most generally used in the United States are 25, 40, 60, 125, and 133 cycles per second. The Standardization Report of the A. I. E. E. recommends the adoption of three frequencies, viz. 25, 60 and 120.

With the higher frequencies both transformers and conductors will be less costly in a circuit of a given resistance but the capacity and inductance effects in each will be increased, and these tend to increase the cost. With high frequencies it also becomes difficult to operate alternators in parallel.

A low frequency current cannot be used on lighting circuits, as the lights will flicker when the frequency drops below a certain figure. For arc lights the frequency should not be less than 40. For incandescent lamps it should not be less than 25. If the circuit is to supply both power and light a frequency of 60 is usually desirable. For power transmission to long distances a low frequency, say 25, is considered desirable, in order to lessen the capacity effects. If the alternating current is to be converted into direct current for lighting purposes a low frequency may be used, as the frequency will then have no effect on the lights.

**Inductance.**—Inductance is that property of an electrical circuit by which it resists a change in the current. A current flowing through a conductor produces a magnetic flux around the conductor. If the current be changed in strength or direction, the flux is also changed, producing in the conductor an e.m.f. whose direction is opposed to that of the current in the conductor. This counter e.m.f. is the *counter e.m.f. of inductance*. It is proportional to the rate of change of current, provided that the permeability of the medium around the conductor remains constant. The unit of

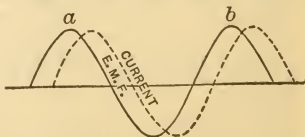

FIG. 228.

Inductance is the *henry*, symbol  $L$ . A circuit has an inductance of one henry if a uniform variation of current at the rate of one ampere per second produces a counter e.m.f. of one volt.

The effect of inductance on the circuit is to cause the current to lag behind the e.m.f. as shown in Fig. 228, in which abscissas represents time, and ordinates represent e.m.f. and current strengths respectively.

**Capacity.**—Any insulated conductor has the power of holding a quantity of static electricity. This power is termed the *capacity* of the body. The capacity of a circuit is measured by the quantity of electricity in it when at unit potential. It may be increased by means of a condenser. A condenser consists of two parallel conductors, insulated from each other by a non-conductor. The conductors are usually in sheet form.

The unit of capacity is a *farad*, symbol  $C$ . A condenser has a capacity of one farad when one coulomb of electricity contained in it produces a difference of potential of one volt, or when a rate of change of pressure of one volt per second produces a current of one ampere. The farad is too large a unit to be conveniently used in practice, and the micro-farad or one-millionth of a farad is used instead. The effect of capacity on a circuit is to cause the e.m.f. to lag behind the current. Both inductance and capacity may be measured with a Wheatstone bridge by substituting for a standard resistance a standard of inductance or a standard of capacity.

**Power Factor.**—In direct-current work the power, measured in watts, is the product of the volts and amperes in the circuit. In alternating-current work this is only true when the current and e.m.f. are in phase. If the current either lags or leads, the values shown on the volt and ammeters will not be true simultaneous values. Referring to Fig. 228, it will be seen that the product of the ordinates of current and e.m.f. at any particular instant will not be equal to the product of the effective values which are shown on the instruments. The power in the circuit at any instant is the product of the simultaneous values of current and e.m.f., and the volts and amperes shown on the recording instruments must be multiplied together and their product multiplied by a power factor before the true watts are obtained. This power factor, which is the ratio of the volt-amperes to the watts, is also the cosine of the angle of lag or lead of the current. Thus

$$P = I \times E \times \text{power factor} = I \times E \times \cos \theta,$$

where  $\theta$  is the angle of lag or lead of the current.

A watt-meter, however, gives the true power in a circuit directly. The method of obtaining the angle of lag is shown on p. 1442.

**Reactance, Impedance, Admittance.**—In addition to the ohmic resistance of a circuit there are also resistances due to inductance, capacity, and skin effect. The virtual resistance due to inductance and capacity is termed the reactance of the circuit. If inductance only be present in circuit, the reactance will vary directly as the inductance. If capacity only be present, the reactance will vary inversely as the capacity.

$$\text{Inductive reactance} = 2\pi fL; \text{ Condensive reactance} = \frac{1}{2\pi fC}$$

The total apparent resistance of the circuit, due to both the ohmic resistance and the total reactance, is termed the impedance, and is equal to the square root of the sum of the squares of the resistance and the reactance.

Impedance  $= Z = \sqrt{R^2 + (2\pi fL)^2}$  when inductance is present in the circuit.

Impedance  $= Z = \sqrt{R^2 + \left(\frac{1}{2\pi fC}\right)^2}$  when capacity is present in the circuit.

Admittance is the reciprocal of impedance,  $= 1 \div Z$ .

If both inductance and capacity are present in the circuit, the reactance of one tends to balance that of the other; the total reactance is the algebraic sum of the two reactances; thus,

$$\text{Total reactance} = X = 2\pi fL - \frac{1}{2\pi fC}; \quad Z = \sqrt{R^2 + \left(2\pi fL - \frac{1}{2\pi fC}\right)^2}$$

In all cases the tangent of the angle of lag or lead is the reactance divided by the resistance. In the last case

$$\tan \theta = \frac{2\pi fL - \frac{1}{2\pi fC}}{R}$$



**Skin Effect.**—Alternating currents tend to have a greater density at the surface than at the axis of a conductor. The effect of this is to make the virtual resistance of a wire greater than its true ohmic resistance. With low frequencies and small wires the skin effect is small, but it becomes quite important with high frequencies and large wires. With magnetic material it is much higher than with non-magnetic.

The skin effect factor, by which the ohmic resistance is to be multiplied to obtain the virtual resistance is given by Berg in the following approximate formula:

$$C_s = \frac{1 + \sqrt{1 + \left(\frac{k}{\delta}\right)^2}}{2}$$

For Copper Cable:  $\left(\frac{k}{\delta}\right) = 0.0105 d^2 f$ ; for Aluminum Cable:  $\left(\frac{k}{\delta}\right) = 0.0063$

$d^2 f$ , where  $d$  = diameter of cable, and  $f$  = frequency.

For the same per cent increase, due to skin effect, a cable can have 13% larger diameter than a solid wire; in other words, the skin effect is the same as long as the ohmic resistance is the same, whether a solid wire or a cable is used.

**Ohm's Law applied to Alternating-Current Circuits.**—To apply Ohm's law to alternating-current circuits a slight change is necessary in the expression of the law. Impedance is substituted for resistance. The law should read

$$I = \frac{E}{\sqrt{R^2 + X^2}} = \frac{E}{Z}$$

**Impedance Polygons.**—1. *Series Circuits.*—The impedance of a circuit can be determined graphically as follows: Suppose a circuit to contain a resistance  $R$  and an inductance  $L$ , and to carry a current  $I$  of frequency  $f$ . In Fig. 229 draw the line  $ab$  proportional to  $R$ , and representing the direction of current. At  $b$  erect  $bc$  perpendicular to  $ab$  and proportional to  $2\pi fL$ . Join  $a$  and  $c$ . The line  $ac$  represents the impedance of the circuit. The angle  $\theta$  between  $ab$  and  $ac$  is the angle of lag of the current behind the e.m.f., and the power factor of the circuit is cosine  $\theta$ . The e.m.f. of the circuit is  $E = IZ$ .

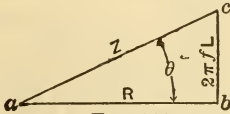

FIG. 229.

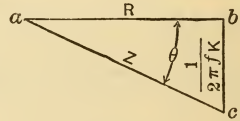

FIG. 230.

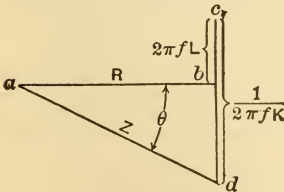

FIG. 231.

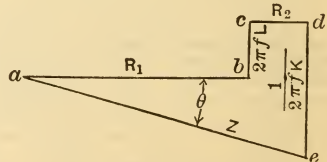

FIG. 232.

If the above circuit contained, instead of the inductance  $L$ , a capacity  $C$ , then would the polygon be drawn as in Fig. 230. The line  $bc$  would be proportional to  $\frac{1}{2\pi fC}$  and would be drawn in a direction opposite to that of  $bc$  in Fig. 229. The impedance would again be  $Z$ , the e.m.f. would be  $Z \times I$ , but the current would lead the e.m.f. by the angle  $\theta$ .

Suppose the circuit to contain resistance, inductance, and capacity, the lines of the impedance polygon would then be laid off as in Fig. 231. The impedance of the circuit would be represented by  $ad$ , and the angle

of lag by  $\theta$ . If the capacity of the circuit had been such that  $cd$  was less than  $bc$ , then would the e.m.f. have led the current.

If between the inductance and capacity in the circuit in the previous examples there be interposed another resistance, the impedance polygon will take the form of Fig. 232. The lines representing either resistances, inductances, or capacities in the circuit follow each other in all cases as do the resistances, inductances, and capacities in the circuit, each line having its appropriate direction and magnitude.

EXAMPLE.—A circuit (Fig. 233) contains a resistance,  $R_1$ , of 15 ohms, a capacity,  $C_1$ , of 100 microfarads (0.000100 farad), a resistance,  $R_2$ , of 12

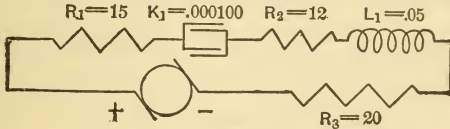

FIG. 233.

ohms, and inductance of  $L_1$ , of 0.05 henry, and a resistance  $R_3$ , of 20 ohms. Find the impedance and electromotive force when a current of 2 amperes is sent through the circuit, and the current when e.m.f. of 120 volts is impressed on the circuit, frequency being taken as 60. Also find the angle of lag, the power factor, and the power in the circuit when 120 volts are impressed.

The resistance is represented in Fig. 234 by the horizontal line  $ab$ , 15 units long. The capacity is represented by the line  $bc$ , drawn downwards from  $b$  and whose length is

$$\frac{1}{2\pi f C_1} = \frac{1}{2 \times 3.1416 \times 60 \times 0.0001} = 26.55.$$

From the point  $c$  a horizontal line  $cd$ , 12 units long, is drawn to represent  $R_2$ . From the point  $d$  the line  $de$  is drawn vertically upwards to represent the inductance  $L_1$ . Its length is

$$2\pi f L_1 = 2 \times 3.1416 \times 60 \times 0.05 = 18.85.$$

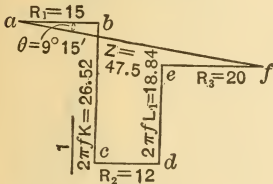

From the point  $e$  a horizontal line  $ef$ , 20 units long, is drawn to represent  $R_3$ . The line adjoining  $a$  and  $f$  will represent the impedance of the circuit in ohms. The angle  $\theta$ , between  $ab$  and  $af$ , is the angle of lag of the e.m.f. behind the current. The impedance in this case is 47.5 ohms, and the angle of lag is  $9^\circ 15'$ .

The e.m.f. when a current of 2 amperes is sent through is

$$IZ = E = 2 \times 47.5 = 95 \text{ volts.}$$

If an e.m.f. of 120 volts be impressed on the circuit, the current flowing through will be

$$I = \frac{120}{Z} = \frac{120}{47.5} = 2.53 \text{ amperes.}$$

The power factor =  $\cos \theta = \cos 9^\circ 15' = 0.987$ .

The power in the circuit at 120 volts is

$$I \times E \times \cos \theta = 2.53 \times 120 \times 0.987 = 299.6 \text{ watts.}$$

2. *Parallel Circuits.*—If two circuits be arranged in parallel, the current flowing in each circuit will be inversely proportional to the impedance of that circuit. The e.m.f. of each circuit is the e.m.f. across the terminals at either end of the main circuit, where the various branches separate. Consider a circuit, Fig. 235, consisting of two branches. The first branch contains a resistance  $R$ , and an inductance  $L_1$  in series with it. The second

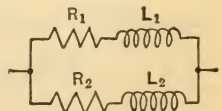

FIG. 235.

branch contains a resistance  $R_2$  in series with an inductance  $L_2$ . The impedance of the circuit may be determined by treating each of the two branches as a separate series circuit, and drawing the impedance polygon for each branch on that assumption. Having found the impedance the current flowing in either branch will be the reciprocal of the impedance multiplied by the e.m.f. across the terminals. The current in the entire circuit is the geometrical sum of the current in the two branches.

The admittance of the equivalent simple circuit may be obtained by drawing a parallelogram, two of whose adjoining sides are made parallel to the impedance lines of each branch and equal to the two admittances respectively.

The diagonal of the parallelogram will represent the admittance of the equivalent simple circuit. The admittance multiplied by the e.m.f. gives the total current in the circuit.

EXAMPLE.—Given the circuit in Fig. 236, consisting of two branches. Branch 1 consists of a resistance  $R_1 = 12$  ohms, an inductance  $L_1 = 0.05$  henry, a resistance  $R_2 = 4$  ohms, and a capacity  $C_1 = 120$  microfarads (0.00012 farad). Branch 2 consists of an inductance  $L_2 = 0.015$  henry, a resistance  $R_3 = 10$  ohms, and an inductance  $L_3 = 0.03$  henry. An e.m.f. of 100 volts is impressed on the circuit at a frequency of 60. Find the admittance of the entire circuit, the current, the power factor, and the power

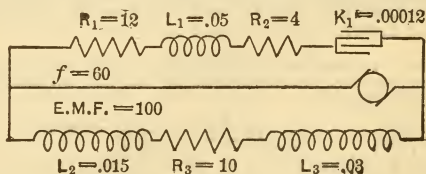

FIG. 236.

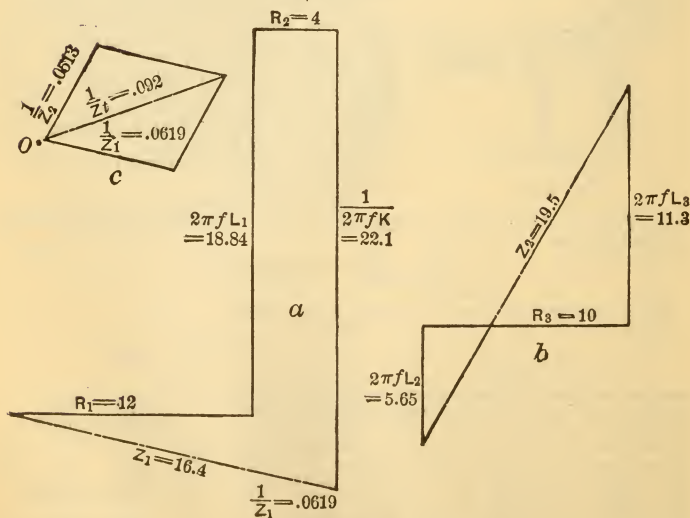

FIG. 237.



in the circuit. Construct the impedance polygons for the two branches separately as shown in Fig. 237, *a* and *b*. The impedance in branch 1 is 16.4 ohms, and the current is  $(1/16.4) \times 100 = 6.19$  amperes. The angle of lead of the current is  $1^\circ 45'$ . The impedance in branch 2 is 19.5 ohms and the current is  $(1/19.5) \times 100 = 5.13$  amperes. The angle of lag of the current is  $61^\circ$ .

The current in the entire circuit is found by taking the admittances of the two branches, and drawing them from the point *o*, in Fig. 237 *c*, parallel to the impedance lines in their respective polygons. The diagonal from *o* is the admittance of the entire circuit, and in this case is equal to 0.092. The current in the circuit is  $0.092 \times 100 = 9.2$  amperes. The power factor is 0.944 and the power in the circuit is  $100 \times 0.944 \times 9.2 = 868.48$  watts.

**Self-Inductance of Lines and Circuits.**—The following formulæ and table, taken from Crocker's "Electric Lighting," give a method of calculating the self-inductance of two parallel aerial wires forming part of the same circuit and composed of copper, or other non-magnetic material:

$$L \text{ per foot} = \left( 15.24 + 140.3 \log \frac{2A}{d} \right) 10^{-9}.$$

$$L \text{ per mile} = \left( 80.5 + 740 \log \frac{2A}{d} \right) 10^{-6}.$$

In which *L* is the inductance in henrys of each wire, *A* is the interaxial distance between the two wires, and *d* is the diameter of each, both in inches. If the circuit is of iron wire, the formulæ become

$$L \text{ per foot} = \left( 2286 + 140.3 \log \frac{2A}{d} \right) 10^{-9}.$$

$$L \text{ per mile} = \left( 12070 + 740 \log \frac{2A}{d} \right) 10^{-6}.$$

INDUCTANCE, IN MILLIHENRYS PER MILE, FOR EACH OF TWO PARALLEL COPPER WIRES.

Interaxial Distance, Ins.	American Wire Gauge Number.											
	0000	000	00	0	1	2	3	4	6	8	10	12
6	1.130	1.168	1.205	1.242	1.280	1.317	1.354	1.392	1.466	1.540	1.615	1.690
12	1.353	1.391	1.428	1.465	1.502	1.540	1.577	1.614	1.689	1.764	1.838	1.913
24	1.576	1.614	1.651	1.688	1.725	1.764	1.800	1.838	1.912	1.986	2.061	2.135
36	1.707	1.745	1.784	1.818	1.856	1.893	1.931	1.968	2.043	2.117	2.192	2.266
60	1.871	1.909	1.946	1.982	2.023	2.058	2.095	2.132	2.208	2.282	2.356	2.432
96	2.023	2.059	2.097	2.134	2.172	2.210	2.246	2.283	2.358	2.433	2.507	2.582

**Capacity of Conductors.**—All conductors are included in three classes, viz.: 1. Insulated conductors with metallic protection; 2. Single aerial conductor with earth return; 3. Metallic circuit consisting of two parallel aerial wires. The capacity of the lines may be calculated by means of the following formulæ taken from Crocker's "Electric Lighting."

$$\text{Class 1. } C \text{ per foot} = \frac{7361 k 10^{-15}}{\log(D \div d)}, \quad C \text{ per mile} = \frac{38.83 k 10^{-9}}{\log(D \div d)}.$$

$$\text{Class 2. } C \text{ per foot} = \frac{7361 \times 10^{-15}}{\log(4h \div d)}, \quad C \text{ per mile} = \frac{38.83 \times 10^{-9}}{\log(4h \div d)}$$

$$\text{Class 3. } \begin{cases} C \text{ per foot of each wire} = \frac{3681 \times 10^{-15}}{\log(2A \div d)}, \\ C \text{ per mile of each wire} = \frac{19.42 \times 10^{-9}}{\log(2A \div d)}. \end{cases}$$

In which *C* is the capacity in farads, *D* the internal diameter of the metallic covering, *d* the diameter of the conductor, *h* the height of the conductor above the ground, and *A* the interaxial distance between two parallel wires all in inches; *k* is a dielectric constant which for air is equal to 1 and for pure rubber is equal to 2.5. The formulæ in classes 2 and 3 assume the wires to be bare. If they are insulated, *k* must be introduced in the numerator and given a value slightly greater than 1.

**Single-phase and Polyphase Currents.**—A single-phase current is a simple alternating current carried on a single pair of wires and is

generated on a machine having a single armature winding. It is represented by a single sine curve.

Polyphase currents are known as two-phase, three-phase, six-phase, or any other number, and are represented by a corresponding number of sine curves. The most commonly used systems are the two-phase and three-phase.

1. *Two-phase Currents.*—In a two-phase system there are two single-phase alternating currents bearing a definite time relation to each other and represented by two sine curves (Fig. 238). The two separate currents may be generated by the same or by separate machines. If by separate machines, the armatures of the two should be positively coupled together. Two-phase currents are usually generated by a machine with two armature windings, each winding terminating in two collector rings. The two windings are so related that the two currents will be  $90^\circ$

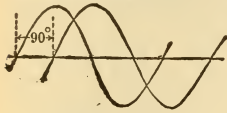

FIG. 238.

apart. For this reason two phase-currents are also called "quarter-phase" currents.

Two-phase currents may be distributed on either three or four wires. The three-wire system of distribution is shown in Fig. 239. One of the return wires is dispensed with, connection being made across to the other as shown. The common return wire should be made 1.41 times the area of either of the other two wires, these two being equal in size.

The four-wire system of distribution is shown in Fig. 240. The two phases are entirely independent, and for lighting purposes may be operated as two single-phase circuits.

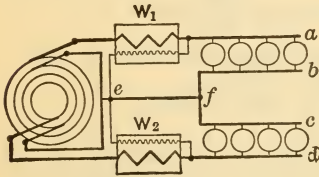

FIG. 239.

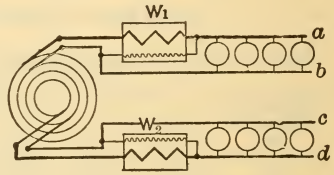

FIG. 240.

2. *Three-phase Currents.*—Three-phase currents consist of three alternating currents, differing in phase by  $120^\circ$ , and represented by three sine curves, as in Fig. 241. They may be distributed by three or six wires. If distributed by the six-wire system, it is analogous to the four-wire, two-phase system, and is equivalent to three single-phase circuits. In the three-wire system of distribution the circuits may be connected in two different ways, known respectively as the Y or star connection, and the  $\Delta$  (delta) or mesh connection.

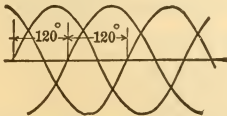

FIG. 241.

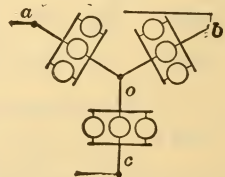

FIG. 242.

The Y connection is shown in Fig. 242. The three circuits are joined at the point *o*, known as the neutral point, and the three wires carrying the current are connected at the points *a*, *b*, and *c*, respectively. If the three circuits *ao*, *bo*, and *co* are composed of lights, they must be equally loaded or the lights will fluctuate. If the three circuits are perfectly balanced, the lights will remain steady. In this form of connection each wire may

be considered as the return wire for the other two. If the three circuits are unbalanced, a return wire may be run from the neutral point  $o$  to the neutral point of the armature winding on the generator. The system will then be four-wire, and will work properly with unbalanced circuits.

The  $\Delta$  connection is shown in Fig. 243. Each of the three circuits  $ab$ ,  $ac$ ,  $bc$ , receives the current due to a separate coil in the armature winding. This form of connection will work properly even if the circuits are unbalanced; and if the circuit contains lamps, they will not fluctuate when the circuit changes from a balanced to an unbalanced condition, or *vice versa*.

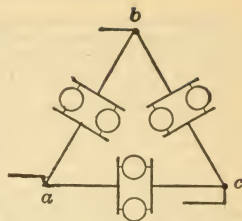

FIG. 243.

**Measurement of Power in Polyphase Circuits.**—1. *Two-phase Circuits.*—The power of two-phase currents distributed by four wires may be measured by two wattmeters introduced into the circuit as shown in Fig. 240. The sum of the readings of the two instruments is the total power. If but one wattmeter is available, it should be introduced first in one circuit, and then in the other. If the current or e.m.f. does not vary during the operation, the result will be correct. If the circuits are perfectly balanced, twice the reading of one wattmeter will be the total power.

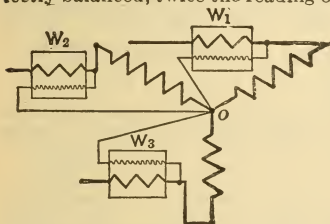

FIG. 244.

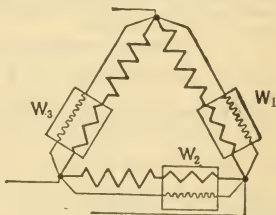

FIG. 245.

The power of two-phase currents distributed by three wires may be measured by two wattmeters as shown in Fig. 239. The sum of the two readings is the total power. If but one wattmeter is available, the coarse-wire coil should be connected in series with the wire  $ef$  and one extremity of the pressure-coil should be connected to some point on  $ef$ . The other end should be connected first to the wire  $a$  and then to the wire  $d$ , a reading being taken in each position of the wire. The sum of the readings gives the power in the circuits.

2. *Three-phase Circuits.*—The power in a three-phase circuit may be measured by three wattmeters, connected as in Fig. 244 if the system is Y-connected, and as in Fig. 245 if the system is  $\Delta$ -connected. The sum of the wattmeter readings gives the power in the system. If the circuits are perfectly balanced, three times the reading of one wattmeter is the total power.

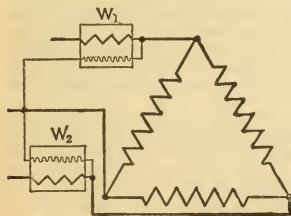

FIG. 246.

The power in a  $\Delta$ -connected system may be measured by two watt-meters, as shown in Fig. 246. If the power factor of the system is greater than 0.50, the arithmetical sum of the readings is the power in the circuit. If the power factor is less than 0.50, the arithmetical difference of the readings is the power. Whether the power factor is greater or less than 0.50 may be discovered by interchanging the relative connection of their coarse- and fine-wire coils. If the deflections of the needles are reversed, the difference of the readings

is the power. If the needles are deflected in the same direction as at first, the sum of the readings is the power.



### ALTERNATING-CURRENT GENERATORS.

**Synchronous Generators.**—The function of the alternating-current synchronous generator is to transform mechanical energy into electrical energy, either single-phase or polyphase. It comprises a comparatively constant magnetic field and an armature generating electro-motive forces and delivering currents in synchronism with the motion of the machine.

Alternating-current generators are generally designed to operate at normal load and 80% power factor without exceeding a specified temperature rise, and should such a machine have to be operated with a load of lower power factor, its rating will be reduced, when based on the same temperature guarantee.

Synchronous generators are almost always of the revolving field type, and may be either of a horizontal or vertical design.

**Rating.**—The normal full-load rating is usually based on continuous operation with a certain rated voltage, current, power factor, frequency and speed. The overload guarantees should refer to the normal conditions of operation, and an overload capacity of 25% for two hours has generally been accepted as standard, although in several instances a 50% two-hour overload is required. Of late (1915), however, generators are often given a maximum continuous rating with a temperature rise not exceeding 50° C. (122° F.).

The rated full-load current is that current which, with rated terminal voltage, gives the rated kilowatts or rated kilovolt-amperes. In machines in which the rated voltage differs from the no-load voltage, the rated current should refer to the former. The rated output may be determined as follows:

If  $E$  = full-load terminal voltage and  $I$  = rated current, then for a single-phase generator, K.V.A. =  $\frac{EI}{1000}$ .

For a two-phase generator the total output is equal to the output of the two single-phase circuits, and if  $I$ , in this case, is the rated current per circuit, the output for a two-phase generator is, K.V.A. =  $\frac{2EI}{1000}$ .

For a three-phase generator there are three circuits to be considered, whether the machine is star or delta connected. If  $E$  is the terminal voltage and  $I$  the line current, then for a three-phase generator,

$$\text{K.V.A.} = \frac{\sqrt{3} \times EI}{1000}.$$

The capacity of a polyphase generator, whether operating two- or three-phase, is always the same, while, if operating under the same conditions single-phase, in which case one phase is ineffective, the rating is only about 71% of what it would be if operated as a polyphase generator. This relation, however, does not hold true for a machine which is initially built for single-phase service, and in such a case the distribution of the winding can be made such as to increase the capacity somewhat. The inherent regulation is generally made poorer thereby, but by the use of massive damping devices it can be materially improved.

**Efficiency.**—The efficiency of a generator is the ratio of the power output to the power input, the difference between these two quantities being equal to the losses. The method commonly and most readily used for obtaining the efficiency is to determine these losses and then compute the efficiency by dividing the power output by the sum of the power output plus the losses.

The guaranteed efficiency should always refer to the energy load (the energy load is the load doing useful work, and is equal to the total K.V.A.  $\times$  the power factor of the load), and it is most important that the power factor of the load is also given. In certain cases the guaranteed efficiency is based on a K.V.A. output, but the inconsistency of such a method is apparent, as the following example will illustrate:

Assume a generator rated 100 K.V.A. (100 Kw. at unity power-factor) or 100 K.V.A. (80 Kw. 0.8 P.F.), and that the losses at unity and 80% power factors are 10 and 11 Kw. respectively, the efficiency is then:

Based on 100 Kw. 1.0 P.F.,

$$\text{Eff.} = \frac{100}{100 + 10} = 91\%.$$

Based on 80 Kw. 0.8 P.F.,

$$\text{Eff.} = \frac{80}{80 + 11} = 88\%.$$

Based on 100 K.V.A. 0.8 P.F.,

$$\text{Eff.} = \frac{100}{100 + 11} = 90\%.$$

From the last two values it is seen that for 80% power-factor if based on the K.V.A., a 2% greater efficiency guarantee can be made, although this value has no meaning, as it is based on apparent power.

The losses in the generator consist of: The copper losses in the armature and field, proportional to the square of the armature and field currents respectively; the core loss, slightly increasing from no-load to full-load; the load loss, having a value approximately one-third of the short-circuiting core loss; and finally, the friction and windage losses, which are practically constant.

**Regulation.**—Such a close inherent voltage regulation as was formerly required is not any longer desirable, since a good voltage regulation may readily be accomplished by means of automatic voltage regulators, which perform their function whether the fluctuations are due to a change of load, speed, or power factor.

A close inherent regulation would require a low reactance generator, which means an expensive machine. A low reactance machine also, in case of short circuits, would allow a very large current to flow through the machine and through any other apparatus that may be within the circuit enclosed by the short-circuit. These short-circuit currents reach enormous values in large central stations, and in order to reduce the currents to safe values large reactances are necessary. It is, however, not possible to design high-speed turbo-generators for the necessary reactance, and external reactances must usually be inserted in the generator leads or between the bus-sections. By so limiting the abnormal flow of current the generating system is relieved from the disastrous effects of such short circuits.

**Rating of a Generating Unit.**—In determining the proper rating and capacity of the generators for a power station, the generator and the prime mover must of necessity be treated together as a combination so as to secure the highest operating efficiency. With steam-engines the ratings are usually such that the engine is working under its most economical load at the rating of the electrical generator. With gas engines, however, the efficiency increases with the load beyond the capacity of the engine, and for this reason the rating of such an engine is generally made as nearly as possible to its maximum capacity with only a small margin for regulating purposes. With steam turbines the efficiency curve is very flat so that it is the desirable overload capacity which limits the rating of the turbine. In the water-wheel unit, the efficiency usually falls off rapidly above and below the maximum point, so that the rating of the generator should correspond to the point of maximum efficiency of the wheel.

The effect of the power factor should also be considered when determining the prime mover as well as the generator capacity, and many mistakes have been made in this respect. The generator may, for example, have been designed and rated on the basis of unity power factor operation with a prime mover having a corresponding capacity. After installation it is, however, found that the actual operating power factor is 0.80, with the result that only 80 per cent of the prime mover capacity can be utilized without overloading the generator.

**Windings.**—The greatest number of all alternating-current generators are wound three-phase with the armature windings connected in star. This is preferable to delta connection, as a smaller number of conductors is required for a given voltage, while on the other hand the danger of the circulation of triple-frequency currents in the closed armature winding is avoided.

**Voltages.**—Standard generator voltages for all frequencies are 240, 480, 600, 1150, 2300, 4000, 6600, with the corresponding motor voltages 220, 440, 550, 1040, 2090, 6000. There is no motor voltage corresponding to 4000 volts, since this is only used on lighting three-phase, four-wire distributing systems. In addition 11,000 volts is also standard for 60 cycles, and 13,200 volts for 25 cycles.

**Parallel Operation.**—In order that an alternating-current generator shall be able to carry a load, a current must flow corresponding to this load. The e.m.f. required to generate this current is the resultant of the terminal and the induced e.m.f.'s of the generator, the displacement between these e.m.f.'s being due to the impulse of the prime mover. In the same manner when two or more generators are operating in parallel the division in load between the different units is entirely dependent on the turning efforts of the prime movers, and a change in the field excitation, as with direct-current generators, will have no effect whatsoever.

For a satisfactory parallel operation it is important that the e.m.f.'s and frequencies of the generators be the same, as, if this is not the case, cross currents will flow between the units. These cross currents may be either wattless or they may represent a transfer of energy, depending on whether they are caused by a difference in the e.m.f. or in the frequency of the machines.

**Exciters (E. A. Lof, in *Coal Age*).**—Synchronous generators as well as synchronous motors are dependent on a direct-current excitation for their operation, and the energy for the excitation is generally obtained from direct-current generators, termed "exciters." These should have a capacity sufficient to excite all of the synchronous apparatus in the station when these machines are operating at their maximum load and true operating power factor. It is not enough to provide for the excitation when operating at unity power factor, because the excitation which is required at lower power factors is considerably higher than at unity power factor.

For small and medium size plants a 125-volt exciter pressure is generally chosen, while for larger installations a 250-volt excitation will prove more economical.

There are many different ways of driving exciters. They may be direct-connected to the main units if these are of moderate speed. Such an arrangement may prove satisfactory for two or three units, but when the number of units is higher the system becomes rather complicated. Another objection is that in case of trouble with an exciter, the whole generating unit will have to be shut down. When two direct-connected units are used, they should each have a capacity sufficiently large to excite both the generators, and with three units the capacity of either exciter should preferably be such that it can excite two of the generators. For four or more units it should only be necessary to give each exciter a capacity sufficient for one generator, and if necessary a motor-driven exciter unit can be installed as a reserve.

The system, however, which seems to be the most widely used and which offers the greatest reliability, is that in which the excitation is obtained from a common source, consisting of as few exciters as possible. One or two units are then generally provided for normal excitation, depending on the size of the station, a third unit being installed as a reserve. It is also common practice to have the regular units driven by prime movers, such as steam-engines or water-wheels, while the reserve unit is motor-driven.

Still another system which is becoming common is to install low-voltage generators, driven either by a non-condensing steam turbine in case of a steam-plant or a water-wheel in a hydro-electric plant. The exciters are then motor-driven, current for driving them being obtained from the low voltage generator. The steam from the turbines would then, of course, be taken to the feed-water heaters, and in addition to the exciters, all the other auxiliaries, such as the circulating pumps, etc., would also be motor-driven.

In order to insure a close voltage regulation of the system, automatic regulators are commonly installed in connection with the exciters, their principle being to automatically increase or decrease the excitation by rapidly opening or closing a shunt circuit across the exciter-field rheostat, and thus keep a constant bus-bar voltage regardless of the load.



## TRANSFORMERS.

A transformer consists essentially of two coils of wire, one coarse and one fine, wound upon an iron core. Its function is to transform electrical energy from one potential to another, although it may also be used for phase transformation. If the transformer causes a change from high to low voltage, it is known as a "step-down" transformer; if from low to high voltage, it is known as a "step-up" transformer.

**Primary and Secondary.**—In regard to the use of the terms high-voltage, low-voltage, primary and secondary, the A.I.E.E. Standardization Rules read as follows:

"The terms 'high-voltage' and 'low-voltage' are used to distinguish the winding having the greater from that having the lesser number of turns. The terms 'primary' and 'secondary' serve to distinguish the windings in regard to energy flow, the primary being that which receives the energy from the supply circuit, and the secondary that which receives the energy by induction from the primary."

The terms primary and secondary are, however, often confused, and in order to avoid any misunderstanding, it is preferable that the terms high-voltage and low-voltage be used instead of primary and secondary.

**Voltage Ratio.**—The A.I.E.E. Standardization Rules also state that "The voltage ratio of a transformer is the ratio of the r.m.s. (square root of mean square) primary terminal voltage to the r.m.s. secondary terminal voltage under specified conditions of load." It also defines "The ratio of a transformer, unless otherwise specified, as the ratio of the number of turns in the high-voltage winding to that in the low-voltage winding: i.e., the *turn-ratio*."

The two ratios are equal when one of the windings is open and the transformer does not carry any load. When loaded, the resistance and inductance of the windings cause a drop in the voltage, thus modifying the ratio of transformation slightly.

**Rating.**—A transformer should be rated by its kilovolt-ampere (K.V.A.) output. It is equal to the product of the voltage and current, and is, therefore, the same whether the different coils are connected in series or parallel. If the load is of unity power factor, the kilowatt output is the same as the kilovolt-ampere output, but if the power factor is less, the kilowatt output will be correspondingly less. For example, a 100 K.V.A. transformer will have a full-load rating of 100 K.W. at 100% power factor, 90 K.W. at 90% power factor, etc.

**Efficiency.**—There are two sources of loss in the transformer, viz., the copper loss and the iron loss. The copper loss is proportional to the square of the current, being the  $I^2 R$  loss due to heat. If  $I_1, R_1$ , be the current and resistance respectively of the primary, and  $I_2, R_2$ , the current and resistance respectively of the secondary, then the total copper loss is  $W_c = I_1^2 R_1 + I_2^2 R_2$  and the percentage of copper loss is

$\frac{I_1^2 R_1 + I_2^2 R_2}{W_p}$ , where  $W_p$  is the energy delivered to the primary. The iron

loss is constant at all loads, and is due to hysteresis and eddy currents.

The efficiency of a transformer is the ratio of the output in watts at the secondary terminals to the input at the primary terminals. At full load the output is equal to the input less the iron and copper losses. The full-load efficiency of a transformer is usually very high, being from 92 per cent to 98 per cent. As the copper loss varies as the square of the load, the efficiency of a transformer varies considerably at different loads. Transformers on lighting circuits usually operate at full load but a very small part of the day, though they use some current all the time to supply the iron losses. For transformers operated only a part of the time, the "all-day" efficiency is more important than the full-load efficiency. It is computed by comparing the watt-hours output to the watt-hours input.

The all-day efficiency of a 10-Kw. transformer, whose copper and iron losses at full load are each 1.5 per cent, and which operates 3 hours at full load, 2 hours at half load, and 19 hours at no load, is computed as follows:

Iron loss, all loads =  $10 \times 0.015 = 0.15$  K.W.

Copper loss, full load =  $10 \times 0.015 = 0.15$  K.W.

Copper loss,  $1/2$  load =  $0.15 \times (1/2)^2 = 0.0375$  K.W.

Iron loss, K.W. hours =  $0.15 \times 24 = 3.6$ .

Copper loss, full load, K.W. hours =  $0.15 \times 3 = 0.45$ .

Copper loss,  $1/2$  load, K.W. hours =  $0.0375 \times 2 = 0.075$ .

Output, K.W. hours =  $\{ (10 \times 3) + (5 \times 2) \} = 40$ .

Input, K.W. hours =  $40 + 3.6 + 0.45 + 0.075 = 44.125$ .

All-day efficiency =  $40 \div 44.125 = 0.907$ .

**Connections.**—Among the great variety of transformer manipulations in power and general distribution work, either for straight voltage transformation or for phase transformation, the following are the most generally used:

Voltage Transformation:

Single-phase.

Two-phase.

Three-phase, delta-delta.

Three-phase, delta-star, and *vice versa*.

Three-phase, star-star.

Three-phase, open-delta.

Three-phase, Tee.

Phase Transformation:

Two- or three-phase to single-phase.

Two-phase to six-phase.

Three-phase to two-phase.

Three-phase to six-phase.

The transformer connections mostly used are delta-delta or delta-star with neutral grounded.

For moderate voltage systems, the isolated delta connection is to be preferred, although for high-tension systems with very high voltages

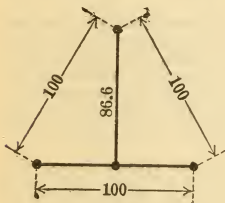

FIG. 247.

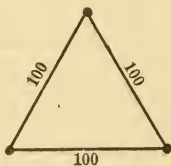

FIG. 248.

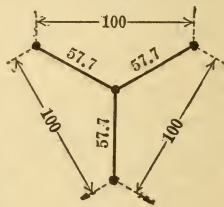

FIG. 249.

practice has proved that the high-tension winding star connected and the neutral grounded will give a more satisfactory operation.

**Tee-Connection.**—(Fig. 247.)—T-connection requires only two single transformers of which one is provided with a 50 per cent tap to which the other is connected. The latter may be designed for only 86.6% of the line or main transformer voltage, but generally it is made identical with the main transformer and operated at reduced flux density.

**Delta-Connection.**—(Fig. 248.)—The e.m.f. between the mains is the same as that in any one transformer measured between terminals, and each transformer must, therefore, be wound for the full line voltage, but only for  $\frac{1}{\sqrt{3}}$  or 57.7 per cent of the line current.

**Star-Connection.**—(Fig. 249.)—In the star-connection each transformer has one terminal connected to a common junction, or neutral point. Each transformer is wound for only 57.7 per cent of the line voltage, but for the full line current.

**Reactance.**—In order to obtain a good voltage regulation, it has been the custom to design the transformers with a reactance as low as  $1\frac{1}{2}$  to 2 per cent. Recent experience has, however, shown that in high power systems such transformers are unsafe, owing to the enormous mechanical strain produced on the transformer and system by the excessive short-circuit currents permitted by such low impedance transformers.

A 2 per cent reactance means that at full load current, 2 per cent or  $1/50$  of the supply voltage is consumed by the reactance. At short circuit the total voltage would have to be consumed by the transformer reactance, and the short-circuit current at full voltage is then fifty times full load current. Safety thus requires that in high power systems the transformers should be designed for a much higher reactance and the present practice (1915) is, therefore, to design such transformers for 6 to 8 per cent reactance, and sometimes even for as high as 10 per cent.

**Cooling.**—According to the method used in dissipating the heat generated by the losses, transformers may be classified as: 1. Oil cooled. 2. Water cooled. 3. Air blast.

**Parallel Operation.**—In order that two or more transformers or groups of transformers shall operate successfully in parallel, it is necessary that their polarity be the same, that their voltages and voltage ratios be identical, and that their impedances be inversely proportional to the ratings.

**Auto Transformers.**—Auto transformers may be used where the required voltage change is small. Their action is similar to that of ordinary transformers, the essential difference between the two being that in the transformer the high-voltage and low-voltage windings are separate and insulated from each other while in the auto-transformer a portion of the winding is common to both the high and low voltage circuits.

The high- and low-voltage currents in both types of transformers are in opposite direction to each other, and thus in an auto-transformer a portion of the winding carries only the difference between the two currents.

Auto transformers are extensively used for alternating current motor starters, and also to some extent in moderate voltage generating stations.

**Constant-Current Transformers.**—The transformers heretofore discussed are constant-potential transformers and operate at a constant voltage with a variable current. For the operation of lamps in series a constant-current transformer is required. There are a number of types of this transformer. That manufactured by the General Electric Co. operates by causing the primary and secondary coils to approach or to separate on any change in the current.

## SYNCHRONOUS CONVERTERS.

A synchronous converter is essentially a continuous-current generator, which, in addition to its commutator, is supplied with two or more collector rings connected to suitable points in the armature winding. If such a machine be driven by mechanical power, it will evidently deliver either alternating or direct current, and, conversely, if supplied with electric power, it will operate either as a synchronous motor, as a direct-current motor, or as a synchronous converter. When operated as a converter, the alternating current enters the armature winding through the collector rings, and after being rectified by the commutator, is delivered as direct current, or *vice versa*.

The alternating and direct current e.m.f. stand in a certain relation or ratio to each other, and this depends upon the number of phases and frequency of the system used, and also upon the ratio of maximum to the square root of the mean square value of the impressed e.m.f. (that is, the e.m.f. of the supply circuit). It also depends upon the load of the machine, the ohmic armature losses, the position of the direct-current brushes on the commutator, the excitation, the ratio of pole arc to pole pitch, and upon the operating conditions, that is, whether the machine is used to convert from alternating to direct current or *vice versa*. Synchronous converters for 60 cycles, which usually have a lower ratio of pole arc to pole pitch than 25 cycle converters, have, as a rule, a higher voltage ratio and, when used as inverted converters, a lower voltage ratio than corresponding 25 cycle machines.

In the two-ring or single-phase converter, the two collector rings are connected to armature conductors with the same angular distance apart as commutator bars under adjacent sets of brushes. At this instant the e.m.f. between the collector rings is at its maximum value and equal to the e.m.f. between the direct-current brushes. Therefore, the direct-current e.m.f. ( $E$ ) of a two-ring single-phase synchronous



converter is equal to the maximum value ( $\sqrt{2} \times E_2$ ) of the sine wave e.m.f. between the two collector rings. Therefore,

$$E_2 = \frac{E}{\sqrt{2}}$$

in which  $E_2$  is the effective value of the single-phase alternating e.m.f.

The effective e.m.f. between the two collector rings, which are connected to the armature winding at points 120 electrical degrees apart, that is, between any two rings of a three-ring three-phase converter, is represented by that chord of a polygon which subtends an angle of 120 degrees. Likewise, the e.m.f. between two rings which are connected to the armature winding at points 90 electrical degrees apart, as between two adjacent rings in a four-ring quarter-phase converter, is represented by the chord which subtends an angle of 90 electrical degrees; and the chord which subtends an angle of 60 electrical degrees represents the e.m.f. between two adjacent rings of a six-ring six-phase synchronous converter.

In general, the effective e.m.f.,  $E_1$ , between adjacent rings of an  $n$ -ring converter, is represented by that chord of a polygon which subtends an angle of  $\frac{360^\circ}{n}$  or  $\frac{2\pi}{n}$ . Therefore,

$$E_1 = \frac{E}{\sqrt{2}} \sin \frac{180^\circ}{n}$$

This gives the following *theoretical* values of the effective alternating e.m.f. between *adjacent* collector rings of a two-ring, three-ring, four-ring and six-ring synchronous converter, expressed in terms of the e.m.f.,  $E$ , between the direct-current brushes:

For single-phase  $E_1 = \frac{E}{\sqrt{2}} = 0.707 E$ ,

For three-phase  $E_1 = \frac{\sqrt{3} E}{2 \sqrt{2}} = 0.612 E$ ,

For quarter-phase  $E_1 = \frac{E}{2} = 0.500 E$ ,

For six-phase  $E_1 = \frac{E}{2 \sqrt{2}} = 0.354 E$ .

The above ratios represent, as before stated, the effective alternating e.m.f. between two *adjacent* collector rings. For quarter- and six-phase converters the different phases of the supply circuit, however, are not connected as a rule to adjacent rings and the ratios given above are not the ones to be used for determining the alternating supply voltage for these types of synchronous converters.

For the four-ring quarter-phase converter, each phase of the supply circuit is generally connected to diametrically opposite points of the armature winding and the ratio will, under such conditions, be equal to the ratio for the two-ring single-phase converters, that is, for quarter-

phase  $E_1 = \frac{E}{\sqrt{2}} = 0.707 E$ .

For six-phase synchronous converters two different arrangements of the connections are generally used. One is called the "double delta" connection and the other the "diametrical" connection. In the first case, the voltage ratio is the same as for the three-phase synchronous converter and simply consists of two "delta" systems. The transformers can also be connected in "double-star," and in such a case the ratio between the three-phase voltage between the terminals of each star and the direct voltage will be the same as for "double-delta,"

while the voltage of each transformer coil, or voltage to neutral, is  $\frac{1}{\sqrt{3}}$  times as much. With the diametrical connection the ratio is the same

as for the two-ring single-phase converter, it being analogous to three such systems. Therefore

$$\text{Six-phase double-delta, } E_1 = \frac{\sqrt{3} E}{2 \sqrt{2}} = 0.612 E.$$

$$\text{Six-phase diametrical, } E_1 = \frac{E}{\sqrt{2}} = 0.707 E.$$

The ratio of the effective e.m.f.,  $E_0$ , between any collector ring and the neutral point is always

$$E_0 = \frac{E}{2 \sqrt{2}} = 0.354 E.$$

The given voltage ratios are, as stated, only *theoretical*, as the losses in the winding have been neglected and the assumption has been made that both the impressed and the counter generated converter e.m.f. has a sine wave shape. The ratio between the alternating and direct terminal voltages is somewhat different from the theoretical ratio due to the voltage drop in the armature and to the wave shapes of the c.m.f.'s. The exact ratios are always furnished by the manufacturer.

Synchronous converters may be either of the shunt- or compound-wound type, the choice depending on the character of the service for which they are to be used. In the majority of installations, especially for power purposes, compound-wound converters are generally used because they automatically regulate for a comparatively constant direct-current voltage.

In order to change the direct voltage in the ordinary type of synchronous converter with constant voltage ratio, it is necessary to provide means for changing the applied alternating voltage correspondingly. This can be done in several ways, one of which is to provide taps on the step-down transformers and adjust the ratio of transformation by means of a dial switch. A much better method, however, is the use of an induction regulator between the transformer secondary terminals and the synchronous converter. This regulator consists of a stationary series winding and a movable potential winding, which can be turned through a certain angle, and at each angular position will raise or lower the voltage at the collector rings a certain amount, through the mutual action of the current and potential windings. This method of control is generally used with shunt-wound synchronous converters in order to keep the voltage constant, when the line drop is excessive. The induction regulator is either hand-operated by means of chain or motor drive, or the control can be made automatic by using a contact-making voltmeter and relay, which will automatically control the regulator motor.

The voltage regulation can also be accomplished by taking advantage of the fact that an alternating current passing over an inductive circuit will decrease in potential if lagging, and increase if leading. By providing the synchronous converter with a series field winding in addition to the shunt field, the excitation can be automatically regulated as the load comes on. The inductance of the supply circuit and step-down transformers is, however, frequently not sufficient to cause the required boost in the voltage, and in such a case it becomes necessary to insert extra reactance coils in the line or provide the step-down transformers with extra high reactance.

There are three feasible methods of starting synchronous converters: First, the application of alternating current at reduced voltage to the collection rings; second, the application of direct current to the commutator and starting the machine as a direct-current motor; third, the use of an auxiliary starting motor mechanically connected.

The alternating current starting method has many advantages over the other methods. It is self-synchronizing, and, therefore, entirely eliminates the difficulty of accurately adjusting the speed. When the speed of the prime movers is liable to be variable, the ability to start a machine quickly and get it on the line in the shortest possible time is a great advantage inherent to this method of starting. It is possible for the converter to drop into step with its direct-current voltage reversed from that of the bus to which the machine is to be connected, but the

machine can easily be made to drop back a pole by a self-exciting field reversing switch on the machine frame. This method of starting makes the operation of the machine so simple that the liability of confusion and mistakes by operators is greatly reduced.

If several synchronous converters are to supply the same direct-current system, they can be connected in parallel in the same manner as shunt- or compound-wound generators, and they are even frequently operated in parallel with such generators and storage batteries. The different converters will divide the load according to their direct-current voltages, and these can be regulated by changing the applied alternating current. It is evidently necessary that all of the machines operating in parallel should have the same voltage regulation from no-load to full-load, and if a battery is also operated in parallel the voltage drop should be sufficiently large so as to cause the battery to take the excessive loads. Synchronous converters operated in parallel should not be connected to the same transformer secondaries. Such a connection would form a closed local circuit in which heavy cross-currents would flow when any difference in the operating conditions of the machine occurs, as, for example, if the brushes of one of the machines were slightly displaced relative to the other.

Compound-wound converters for parallel operation should be provided with equalizer switches. For connecting a compound-wound converter in parallel with one already running, the equalizer switch is closed first, so as to energize the series field from the running machine. Next, the shunt field circuit is closed and the field adjusted so that the voltage will correspond to that of the first machine, and finally the main switch is closed. The load can then be transferred from the first to the second converter by weakening the shunt field of the former and strengthening that of the latter.

### MOTOR-GENERATORS.

Motor-generator sets may be divided into three general classes:

1. Direct current to direct current sets, including balancing sets for three-wire lighting systems, and for variable speed motor work, boosters for storage battery charging and railway or lighting feeders.

2. Alternating current to direct current sets or *vice versa*. These are used for excitation purposes and for supply of lighting, railway or power systems. The sets may be driven either with synchronous or induction motors, the former being equipped with an auxiliary squirrel cage winding on the fields so as to be self-starting at reduced voltage.

3. Alternating current to alternating current sets between the two periodicities; commonly called "frequency changers."

**Balancers.**—The balancer set, a form of direct-current compensator, is a variation of the regular motor-generator set, in that the units of which it is composed may be, alternately, motor or generator, and the secondary circuit is interconnected with the primary. On account of the latter feature, the efficiency of transformation is higher and a larger output is obtainable from a given amount of material than in the straight motor-generator set.

Balancer sets are widely used to provide the neutral of Edison three-wire lighting systems. They are also installed for power service in connection with the use of 250-volt motors on a 500-volt service or 125-volt motors on a 250-volt service.

The potential of the system being given, the capacity of a three-wire balancer set is fixed by the maximum current the neutral wire is required to carry. This figure is a more definite specification of capacity than a statement in per cent of unbalanced load.

As designed for power work and generally for lighting service, the brushes of each machine are set at the neutral point in order to get the best results for operating alternately either as a generator or motor. Where the changes of balance are so gradual as to permit of hand adjustment, if desired, a considerable increase in output is obtainable.

**Boosters.**—Boosters are extensively used in railway stations to raise the potential of the feeders extending to distant points of the system; for storage-battery charging and regulation; and in connection with the Edison three-wire lighting system. The design of the various sets is closely dependent upon their application.



Booster sets are constructed in either series- or shunt-wound types, and they may be arranged for either automatic or hand regulation, depending on the nature of the service required.

Where there are a number of lighting feeders connected and run at full load for only a short time each day it will generally be economical to install boosters rather than to invest in additional feeder copper. It is important, however, to consider each case where the question of installing a booster arises, as a separate problem, and to determine if the value of the power lost represents an amount lower than the interest charge on the extra copper necessary to deliver the same potential without the use of a booster.

**Dynamotors.**—A dynamotor is a machine for reducing a direct-current voltage, and it is extensively used in connection with high voltage railway equipments for obtaining a moderate voltage for the control. It has two armature windings and commutators on one drum, with the field between them. The control current is taken midway between the armatures and is returned to the ground side of the dynamotor. This insures that the maximum potential on the control circuit, under normal conditions, will be approximately one-half of the line voltage, and the potential to grounded parts no greater than when operated directly on a line voltage of one-half the amount.

**Frequency Changers.**—A periodicity of 25 cycles has been quite generally selected for railway service. Also in certain large cities, current of the same frequency is generated in central stations and distributed to substations in which are installed rotary converters supplying an Edison three-wire network.

Inasmuch as the periodicity of 60 cycles is more favorable than 25 cycles for alternating current lighting, frequency changers, similar to that shown above, are installed to furnish high tension 60-cycle current for distribution to outlying districts beyond the reach of the three-wire system.

In the design of frequency changers speeds must be selected that are common to the two periodicities of the system upon which they are to be used; since 300 r.p.m. is the highest speed common to 25 and 60 cycles, at which speed small sets are expensive per kilowatt, a line of sets with 4 or 8 pole motors and 10 or 20 pole generators has been developed, giving  $62\frac{1}{2}$  cycles from 25 cycles or 60 cycles from 24 cycles.

Where parallel operation is required between synchronous motor-driven frequency changers, a mechanical adjustment is necessary between the fields or armatures of the generator and motor to obtain equal division of the load. The adjustment is best obtained by the cradle construction. The stator of one machine is bolted to a cradle fastened to the base, and by taking out the bolts the frame can be turned around through a small angle relatively to the cradle, and therefore to the stator field of the other machine, where the bolts can be replaced.

**The Mercury Arc Rectifier** consists of a mercury vapor arc enclosed in an exhausted glass vessel into which are sealed two terminal anodes connected to the two wires of an alternating-current circuit. A third terminal, at the bottom of the vessel, is a mercury cathode. When an arc is operating, it is a good conductor from either anode to the cathode, but practically an insulator in the other direction. The two anodes connected across the terminals of the alternating-current line become alternately positive and negative. While either anode is positive, there is an arc carrying the current between it and the cathode. When the polarity of the alternating-current reverses, the arc passes from the other anode to the mercury cathode, which is always negative. The current leading out from the mercury cathode is uni-directional. By means of reactances, the pulsations are smoothed out and the current at the cathode becomes a true direct current with pulsations of small amplitude.

## ALTERNATING-CURRENT CIRCUITS.

**Calculation of Alternating-current Circuits.**—The following formulæ and tables are issued by the General Electric Co. They afford a convenient method of calculating the sizes of conductors for, and determining the losses in, alternating-current circuits. They apply only to circuits in which the conductors are spaced 18 inches apart, but a slight increase or decrease in this distance does not alter the figures appreciably. If

the conductors are less than 18 inches apart, the loss of voltage is decreased, and *vice versa*.

Let  $W$  = total power delivered in watts;

$D$  = distance of transmission (one way) in feet;

$P^*$  = per cent loss of *delivered* power ( $W$ );

$E$  = voltage between main conductors at consumer's end of circuit;

$K$  = a constant; for continuous current = 2160;

$T$  = a variable depending on the system and nature of the load; for continuous current = 1;

$M$  = a variable, depending on the size of wire and frequency; for continuous current = 1;

$A$  = a factor; for continuous current = 6.04.

$$\text{Area of conductor, circular mills} = \frac{D \times W \times K}{P \times E^2};$$

$$\text{Current in main conductors} = W \times T \div E;$$

$$\text{Volts lost in lines} = P \times E \times M \div 100;$$

$$\text{Pounds copper} = \frac{D^2 \times W \times K \times A}{P \times E^2 \times 1,000,000}$$

The value of  $M$  is found from the formula:  $M = \left(1 + \frac{X}{R} \tan a\right) \cos^2 a$ .

$$X = 0.000882 f \left[ \log_{10} \left( \frac{d}{r} \right) + 0.109 \right]$$

$X$  = Reactance.

$R$  = Resistance, ohms per 1000 ft., at 60° F. (Wire 100% Matthesen's standard.)

$d$  = inches between wires.

$r$  = radius of wire, inches.

$f$  = cycles per second.

	VALUES OF $M$ —WIRES 18 IN. APART.†								WIRES 36 IN. APART.‡			
	25 Cycles.				60 Cycles.				25 Cycles.			
Power Factors.	0.95	0.90	0.85	0.80	0.95	0.90	0.85	0.80	0.95	0.90	0.85	0.80
Wire Sizes.												
0000	1.17	1.16	1.12	1.06	1.53	1.64	1.67	1.66	1.22	1.23	1.20	1.15
000	1.12	1.09	1.05	0.99	1.41	1.49	1.50	1.47	1.16	1.15	1.11	1.05
00	1.08	1.04	0.99	.92	1.32	1.36	1.35	1.31	1.11	1.08	1.04	0.97
0	1.05	1.00	.94	.87	1.24	1.26	1.24	1.19	1.07	1.03	0.98	.91
1	1.02	0.96	.90	.83	1.18	1.17	1.14	1.08	1.04	0.99	.93	.86
2	1.00	.93	.86	.79	1.12	1.10	1.06	1.00	1.02	.95	.89	.82
3	0.98	.91	.84	.76	1.08	1.05	0.99	0.93				
4	.96	.89	.81	.74	1.05	1.00	.94	.87				
5	.95	.88	.80	.72	1.02	0.97	.90	.83				
6	.94	.86	.78	.70	1.00	.94	.87	.79				
7	.94	.85	.77	.69	0.98	.91	.84	.76				
8	.93	.85	.76	.68	.97	.89	.82	.74				
9	.92	.84	.76	.67	.95	.88	.80	.72				
10	.92	.83	.75	.67	.94	.86	.79	.71				

‡ For higher voltages, 10,000 to 200,000.

Per cent of Power Factor.	Value of $K$ .				Value of $T$ .				Value of $A$ .
	100	95	85	80	100	95	85	80	
System:									
Single-phase.....	2160	2400	3000	3380	1.00	1.05	1.17	1.25	6.04
Two-phase, 4-wire.....	1080	1200	1500	1690	0.50	0.53	0.59	0.62	12.08
Three-phase, 3-wire.....	1080	1200	1500	1690	0.58	0.61	0.68	0.72	9.06

\*  $P$  should be expressed as a whole number, not as a decimal; thus a 5 per cent loss should be written 5, not .05.

† As corrected by Harold Pender, see *Elect. World*, July 1, 1905. The formula for  $M$  is approximate, and gives values correct within 2% for any case likely to arise in practice.

**Relative Weight of Copper Required in Different Systems for Equal Effective Voltages.**

Direct current, ordinary two-wire system.....	1.000
“ “ three-wire system, all wires same size.....	0.375
“ “ “ neutral one-half size.....	0.313
Alternating current, single-phase two-wire, and two-phase four-wire.....	1.000
Two-phase three-wire, voltage between outer and middle wire same as in single-phase two-wire.....	0.729
“ “ “ voltage between two outer wires same... ..	1.457
Three-phase three-wire.....	0.750
“ “ four-wire.....	0.333

The weight of copper is inversely proportional to the squares of the voltages, other things being equal. The maximum value of an alternating e.m.f. is 1.41 times its effective rating. For derivation of the above figures see Crocker's "Electric Lighting," vol. ii.

**Approximate Rule for Size of Wires for Three-Phase Transmission Lines. (General Electric Co.)**

The table given below is for use in making rough estimates for the sizes of wires for three-phase transmission, as in the following example.

Required.—The size of wires to deliver 500 Kw. at 6000 volts, at the end of a three-phase line 12 miles long, allowing an energy loss of 10% and a power factor of 85%. If the example called for the transmission of 100 Kw. (on which the table is based), we should look in the 6000-volt column for the nearest figure to the given distance, and take the size of wire corresponding. But the example calls for the transmission of five times this amount of power, and the size of wire varies directly as the distance, which in this case is 12 miles. Therefore we look for the product 5 × 12 = 60 in the 6000-volt column of the table. The nearest value is 60.44 and the size of wire corresponding is No. 00, which is, therefore, the size capable of transmitting 100 Kw. over a line 60.44 miles long, or 500 Kw. over a line 12 miles long, as required by the example.

If it is desired to ascertain the size of wire which will give an energy loss of 5%, or one-half the loss for which the table is computed, it is only necessary to multiply the value obtained by 2, since the area varies inversely as the per cent energy loss.

**DISTANCES TO WHICH 100 KW. THREE-PHASE CURRENT CAN BE TRANSMITTED OVER DIFFERENT SIZES OF WIRES AT DIFFERENT POTENTIALS, ASSUMING AN ENERGY LOSS OF 10% AND A POWER FACTOR OF 85%.**

Number B. & S.	Area in Circular Mils.	Distance of Transmission for Various Potentials at Receiving End, in Miles.								
		2,000	4,000	6,000	8,000	10,000	15,000	20,000	25,000	30,000
6	26,250	1.32	5.28	11.92	21.12	33.1	74.50	132.4	206.75	298
5	33,100	1.66	6.64	15.00	26.56	41.6	93.75	166.4	260.00	375
4	41,740	2.10	8.40	18.96	33.60	52.6	118.50	210.4	328.75	474
3	52,630	2.54	10.16	23.84	40.64	66.2	149.00	254.8	413.75	596
2	66,370	3.33	13.32	30.04	53.28	83.4	187.75	333.6	521.25	751
1	83,690	4.21	16.84	37.92	67.36	105.3	212.00	421.2	658.00	948
0	105,500	5.29	21.16	47.68	84.64	132.4	298.00	529.6	827.50	1192
00	133,100	6.71	26.84	60.44	107.36	167.9	377.75	671.6	1049.25	1511
000	167,800	8.45	33.80	76.16	135.20	211.4	476.00	845.6	1321.25	1904
0000	211,600	10.62	42.48	95.68	169.92	265.7	598.00	1062.8	1660.50	2392
	250,000	12.58	50.32	113.32	201.28	314.7	708.25	1258.8	1966.75	2833
	500,000	25.17	100.68	226.64	402.72	629.4	1416.50	2517.6	3933.75	5666

**Notes on High-tension Transmission.**—The cross-sectional area and, consequently, weight of conductors vary inversely as the square of the voltage for a given power transmission. The cost of conductors is therefore reduced 75% every time the voltage is doubled. The cost of other apparatus and appliances increases with increasing voltage. For long-distance lines the saving in copper with the highest practicable voltages is so great that the other expenses are rendered practically negligible. In the shorter lines, however, the most suitable voltage must be determined



in each individual case. The voltages in the following table will serve as a guide.

VOLTAGES ADVISABLE FOR VARIOUS LINE LENGTHS.

Miles.	Volts.	Miles.	Volts.	Miles.	Volts.
1	500-1000	3-10	6600-13,200	20-40	44,000- 66,000
1-2	1000-2300	10-15	13,200-22,000	40-60	66,000- 88,000
2-3	2300-6600	15-20	22,000-44,000	60-100	88,000-110,000

Standard machinery is made for 2300, 6600, 13,200, 22,000, 33,000, 44,000, 66,000, 88,000 and 110,000 volts, and standard generators are made for the above voltages up to and including 13,200 volts. When the line voltage is higher than 13,200, step-up transformers must be employed. In a given case the saving in cost of conductor by using the higher voltage may be more than offset by the cost of transformers, and the question of voltage must be determined for each case.

*Line Spacing.*—Line conductors should be so spaced as to lessen the tendency to leakage and to prevent the wires from swinging together or against the towers. With suspended disk insulators the radius of free movement is increased, and special account should be taken of spacing when these insulators are used. The spacing should be only sufficient for safety, since increased spacing increases the self-induction of the line, and while it lessens the capacity, it does so only in a slight degree. The following spacing is in accordance with average practice.

CONDUCTOR SPACING ADVISABLE FOR VARIOUS VOLTAGES.

Volts.	Spacing.	Volts.	Spacing.
33,000.....	3 feet.	88,000.....	8 feet.
44,000.....	4 feet.	110,000.....	10 feet.
66,000.....	6 feet.	140,000.....	12 feet.

*Aluminum Conductors.*—The conductivity of aluminum is generally taken at 63.3%, that of hard-drawn copper of the same cross-sectional area. The weight of Al is 30.2% that of copper, and therefore an Al conductor of the same length and conductivity as a given copper conductor weighs 47.7% as much. The cost of Al must therefore be 2.097 times that of hard-drawn copper to give equal cost for the same length and conductivity. Owing to the mechanical unreliability of solid Al conductors, stranded conductors are used in all sizes, including even the smallest.

**The Size of the Line Conductors** depends on both economical and electrical considerations, except where the length of the span is the governing feature. With expensive steel towers it becomes necessary to string the conductors for higher stresses so as to reduce the sags and consequently the height of the towers as much as possible. It has, therefore, become a general practice to erect the conductors so that the stress at the worst load conditions equals one-half the ultimate strength of the conductor material, which gives a factor of safety of two. The load to which a line conductor is subjected, besides its own weight and ice, is acting in a vertical direction, the pressure imposed by the wind acting in a horizontal direction. It is also evident that the stress will be greater in extremely cold weather because of the contraction of the wires, and it is generally agreed that the worst load condition would occur at 0° F. with an actual wind velocity of 56 miles per hour (8 pounds pressure per square foot projected area) and with an ice covering one-half inch thick. The maximum temperature is considered to be 130° F., and the cables should be so supported that at this temperature the sag does not become excessive, but allows a clearance between the lowest conductor and ground of from 25 to 30 feet.

Line conductors may be either of copper or aluminum. It is advisable for mechanical reasons in spans of 200 to 300 feet never to use smaller cable than No. 5 B. & S. copper, or No. 1. B. & S. aluminum (equivalent of No. 3 copper). For spans greater than 300 feet, the minimum sizes of cable allowable are those which will give a reasonable sag at the most severe climatic conditions assumed. Frequently the size of conductors,

determined by electrical considerations, limits the length of spans to a smaller value than is economical. This may occur even with moderately long spans—500 to 600 feet—when the character of the country is such as to make transportation costly or when expensive foundations must be used. In such cases it will often be found that a saving can be made by increasing the size of conductor, thereby allowing an increase in the length of span and the use of fewer towers of approximately the same height and not greatly increased weight.

The sag or deflection at the center of a span can be figured by the formula:

$$D = \frac{S^2 \times W}{8 T},$$

where  $D$  = deflection in feet;  $S$  = length of span in feet;  $W$  = resultant of weight and wind in lbs. per foot of cable;  $T$  = tension on cable in lbs.

**A 135,000-Volt Three-phase Transmission System** from Cook Falls, Mich., to Flint, Mich., 125 miles distant, is described in *Power*, Aug. 9, 1910. The generating equipment comprises three 3000-K.W. 60-cycle alternators, mounted on horizontal shafts driven by water-wheels. The available head of water is 40 ft., and the flow averages 1100 cu. ft. per second. The transmission line consists of three No. 0 copper wires carried on suspension-type insulators hung from the cross-arms of 55-ft. tripod steel towers. The wires are at the angles of an isosceles triangle with a 12-ft. base and 17-ft. sides, the lowest wire 40 ft. above the ground. The insulators have eight disks linked in series, each disk having been tested to withstand continuously 75,000 volts, and subjected to 100,000 volts for a brief period.

## ELECTRIC MOTORS.

**Classification.**—Motors may be classified according to type, speed, and mechanical features. The first cover:

Direct Current—1. Series. 2. Shunt. 3. Compound.

Alternating Current (single-phase and polyphase) — 1. Synchronous. 2. Synchronous Induction. 3. Induction. 3a. Phase-wound. 3b. Squirrel-Cage. 4. Commutator.

According to their speed, they are classified as—

Constant Speed: covering cases where the speed is constant or varies slightly.

Adjustable Speed: covering cases where the speed may be varied over a considerable range, but when once fixed remains at this value independent of the load changes.

Varying Speed: covering cases where the speed changes with the load, usually decreasing as the load increases.

Multi-Speed: covering cases where several distinct speeds may be obtained by changing the connections of the windings or by other means.

According to their mechanical features motors may be classified as: (1) Open. (2) Mechanically Protected. (3) Semi-Enclosed. (4) Totally Enclosed. (5) Enclosed, Externally Ventilated. (6) Enclosed, Self-Ventilated. (7) Moisture Proof. (8) Splash and Water Proof. (9) Submergible. (10) Acid Proof. (11) Explosion Proof.

**Limitations.**—The principal limitations in the ratings of motors are: (1) Mechanical Strength. (2) Heating. (3) Commutation. (4) Regulation. (5) Efficiency.

## CHARACTERISTICS OF MOTORS AFFECTING THEIR APPLICATIONS.

(D. B. Rushmore, "American Handbook for Electrical Engineers.")

**Series Motor.**—This motor is used when a powerful starting torque and rapid acceleration are required, without an excessive instantaneous demand of energy. The torque is practically independent of the voltage and at low-flux densities varies directly as the square of the current, but as the magnetization approaches saturation it becomes more nearly proportional to the first power of the current. The maximum torque exists at

low speed, this being the most valuable feature of the series motor. Dangerously high speeds may be attained by the armature with very light loads, and series motors should for this reason be either geared or direct connected to the load.

**Speed Control of Series Motor.**—The speed of a series motor on constant potential varies automatically with the load, increasing as the load decreases. The speed may, however, be adjusted if some means of varying the impressed voltage is provided. As the work required of a series motor is very often intermittent in character, the insertion of resistance in the armature circuit to reduce the speed is permissible from an economic standpoint in such cases. In others, such as railway work, where two or four motors are used, reduced voltage is most readily and economically obtained by connecting the motors in series or in series parallel.

**Shunt Motor.**—This motor has good starting characteristics and a practically constant speed, varying only slightly with load changes. The speed can, however, be adjusted, either by changing the e.m.f. impressed on the armature or by changing the field flux.

**Speed Adjustment by Armature-voltage Control, i.e.,** by changing the e.m.f. impressed on the armature, does not change the full-load torque which the motor is capable of exerting, since the rated torque depends only upon field flux and rated armature current. These methods are therefore constant-torque methods and are properly adapted to loads in which the torque remains constant regardless of speed. The method most generally used for varying the impressed e.m.f. with a single-voltage system is by means of inserting resistance in series with the armature. The efficiency with this method is, of course, very low at slow speeds. The speed regulation with varying loads may also be very poor.

There are several systems of controlling the motor speeds by applying different voltages, such as by the use of three-wire generators or two-wire generators with balancer sets or by the Ward Leonard system. This latter system, which is the most practical, consists of a constant-speed motor driving a generator which supplies current to the motor whose speed is to be adjusted. This arrangement is very satisfactory, but on account of the expense of providing three full-sized machines instead of one to perform the work, the cost may be prohibitive except with very large motors, such as for hoists, etc.

**Speed Adjustment by Shunt-field Control, i.e.,** by inserting resistance in the shunt-field circuit, is the simplest of all methods of speed variation, but with ordinary shunt motors the range of speed variation by this means is small. Where a variation of more than from 20 to 30 per cent is desired, a motor of modified design and of a certain increased size is generally required, because the field must be more powerful with respect to the armature than in the case of standard single-speed motors. Variable-speed motors of the field-weakening type are not constant torque, but constant-output motors, i.e., the torque falls proportionally as the speed increases.

A speed variation up to 3 to 1 meets, as a rule, all requirements, and such motors can readily be obtained in commercial sizes. Should a greater speed variation be desired, say 4 to 1 or 5 to 1, it is possible to accomplish this by the commutating-pole shunt motor with field control only. A combined field and armature control would, however, be a better method.

**Compound Motor.**—This motor is provided with both a series and a shunt field. The two fields are usually connected so that they act in the same direction, in which case the motor is called a "cumulative" compound motor. "Differential" compound motors, with the two fields opposing, are sometimes employed for special services. The cumulative, or ordinary, compound motor combines the characteristics of the shunt and series motors, having a speed not extremely variable under load changes, but developing a powerful starting torque and an increasing torque with decreasing load. Motors having a comparatively weak series field are employed extensively in shop practice where the motor may be required to start under heavy load, but must maintain an approximately constant speed after starting, or when the load is removed. The heavily compounded motor is used where powerful starting torque and rapid acceleration are necessary, with a speed not varying too widely under load changes, such as for rolling mills, etc.

The speed control employed with compound motors may be any of the various methods explained in connection with the shunt motor. For



certain service the control may be entirely rheostatic, the series winding being cut out after the motor has come up to speed.

**Induction Motor.**—The induction motor is essentially a constant-speed machine, although the speed may be varied either by varying the applied stator frequency or by introducing resistance in the rotor circuit. It is built in two distinct types, namely, the squirrel-cage and the phase-wound.

**Squirrel-cage Motor.**—The squirrel-cage type is used for constant-speed service with infrequent starting. It has a relatively small starting torque per ampere and draws a large starting current from the line. By increasing the resistance of the rotor, it may, however, also be built in the smaller sizes for a high starting torque, rapid acceleration and frequent starting, for such applications as sugar and laundry centrifugals, etc., where simplicity of control is desirable. They are also used for operating punches, shears, etc., where a fly-wheel is provided for storing the energy.

**Induction Motor with Wound Rotor.**—For service requiring high starting torque combined with moderate starting current a motor with the wound type of rotor is best adapted. A motor with the resistance mounted inside the rotor should not be used to operate machinery having large inertia or excessive static friction, since full starting current may be required for a long period before the apparatus attains full speed, and, as the capacity of the internal resistance is small, excessive temperatures may result. This type of motor is, as a rule, not built above 200 horse-power, due to mechanical difficulties involved in connection with the internal resistance.

A motor with external resistance should be used for moderate and large sizes. The rotor must then be provided with collector rings and brushes. The contact resistance of these as well as the leads and the controller fingers, which are in the circuit all the time, may impair the efficiency and regulation of the motor, especially if the controller and the resistance are located some distance from the motor. The phase-wound induction motor with an external variable-rotor resistance is best adapted for a variable-speed service, as the losses necessary to obtain reduced speeds are external to the motor itself.

**Multi-speed Induction Motors.**—It often happens that the service is such that two or three speeds will be satisfactory for the operation of the machinery and that these speeds must be independent of the load. Under such conditions multi-speed motors can frequently be used. In these motors the different synchronous speeds are produced by changing the number of poles in the magnetic circuit. Each of these speeds is fixed, if no resistance is used in the secondary circuit. With multi-speed motors, as with single-speed motors, however, resistance may be used in the secondary circuit for varying the speed.

A change of the number of poles may be made in any of the following ways:

1. By the use of single magnetic and electric circuits, changing the number of poles by re-grouping the coils.
2. By the use of single magnetic circuits and independent electric circuits.
3. By means of separate magnetic and electric circuits, the so-called Cascade connection.

**Synchronous Motor.**—The speed of a synchronous motor is constant, being fixed by the number of poles and the frequency of the applied voltage. The single-phase type is not self-starting and the polyphase type has in itself a very poor starting torque. They may, however, be made self-starting in the same manner as squirrel-cage induction motors, by the use of an amortisseur or cage-winding, similar in construction to that used for induction motors.

The speed-torque curve of a synchronous motor is similar to that of an induction motor except that the torque values are lower for a given resistance of rotor winding on account of the construction of the machine. The starting winding must be designed with both the load at start and the load at synchronous speed in mind, because too great a slip may cause the motor to shut down when the field is put on. It is, however, seldom that the same motor will be called upon to start a heavy load and at the same time synchronize a heavy load, as the load usually consists principally of either static friction, as in the use of motor-generator sets, line shafting, etc., or it comes up with the speed as in the case of a fan blower or centrifugal pump. The former case would be met by a high-resistance squirrel-cage winding and the latter would require a low resistance.

**Single-phase Series Motor.**—This type of commutator motor has a very powerful starting torque, high power factor, and relatively high efficiency. It is most generally used for traction work, the speed being controlled by varying the applied voltage which can most readily be done by means of an auto-transformer with a number of taps.

**Repulsion Induction Motor.**—This type of commutator motor has a limited speed and an increase of torque with decrease in speed. The action of the compensating field insures a power factor approximately unity at full load and closely approaching unity over a wide range in load. In addition, it serves to restrict the maximum no-load speed and also permits, where varying speed service is involved, an increase over the synchronous speed.

**Starting of Repulsion Motors.**—A repulsion motor, if started by directly closing the line switch, will develop about  $2\frac{1}{2}$  times full-load torque. The starting current corresponding to full-load starting torque is from 2 to  $2\frac{1}{4}$  times full-load running current. As a general rule, starting boxes are not required up to and including 2-horse-power rating. From 2 to 5 horse-power the use of a rheostat is optional, dependent upon the degree and care to be exercised in maintaining voltage regulation. Starting boxes should, however, preferably be used on sizes above 5 horse-power, especially where light and power circuits are combined.

**Reversible Repulsion Motors.**—The repulsion motor may be designed for reversible service. This is accomplished by adding an auxiliary reversing winding spaced  $90^\circ$  from the main field winding and connected in series with it. By reversing the relative polarity of the two windings, the direction of rotation is changed in a simpler manner than by mechanical shifting of the brush holder yoke. Instant reversal may be effected from full speed in one direction to full speed in the other, about 200 per cent of normal running torque being developed at the moment of speed reversal in either direction.

**Variable-speed Repulsion Motors.**—In addition to the constant-speed repulsion motor, two other types are also available, one for constant-torque and variable-speed service, the other for adjustable speed independent of torque. In general, variable-speed repulsion motors are not applicable to lathes, boring mills, or similar machines where the service requires adjustable speed and constant horse-power at all speeds below and above normal. When a certain amount of variable speed is required at approximately constant torque, such as in driving fans, blowers, printing presses, etc., the repulsion motor successfully meets a wide field of application.

### MOTOR APPLICATIONS.

**Pumps** (E. A. Lof, in *Coal Age*).—Pumps are either of the reciprocating or centrifugal type. In the former the volume of water can be varied either by changing the speed or by the use of a by-pass valve. The latter method is, of course, less economical, and speed variation is, therefore, preferable. In starting large pumps the water may, however, be delivered through a by-pass until the motor is up to speed, when this passage is gradually closed and the water delivered into the pipe system. The load at starting, therefore, only consists of the friction losses, and usually does not exceed 25 per cent of the full-load torque.

Either direct- or alternating-current motors may be used for driving reciprocating pumps. When of the former class, the compound-wound type is generally selected for single-acting pumps on account of their rather pulsating load, while for duplex and triplex pumps, having steadier characteristics of power demand, the shunt-wound motor is used to advantage. Both squirrel-cage and phase-wound induction motors are suitable, the latter as a rule being selected where it is desirable to reduce the starting current to a minimum or where a somewhat variable speed is required.

Synchronous motors may also be used for driving large pumps of moderate speed, and are admirably adapted for such service, while their characteristics are such that by over-exciting their fields they may be made to considerably improve the power factor of the system. By-pass valves should preferably be provided on the pumps, when this type of motor is employed, so as to reduce the starting current as much as possible.

In selecting the motor equipment for a centrifugal pump, its characteristics as affected by the service conditions must be carefully predetermined,

and in some respects the operating features of this type of water lift are entirely opposite to those of reciprocating pumps.

With constant speed an increase of the resistance against which the reciprocating pump operates increases the water pressure and, therefore, the load on the motor, while with the centrifugal pump an increase of the resistance reduces the load. The volume of water delivered by a reciprocating pump is not affected by the reduction of the head, but the required power is lessened. A reduction of the head with a centrifugal pump, however, increases the volume of water, and as the efficiency at the same time goes down rapidly, the load increases. It is, therefore, of importance to know what this overload, caused by a reduction of the head, amounts to, and the duration of the overload; and the capacity of the motor should, as a rule, be governed by the low- and not the high-head conditions.

The starting condition must be given careful consideration in selecting the motors. In starting a centrifugal pump the discharge valve may be entirely closed until the motor comes up to speed, so that the latter may start as nearly light as possible. As the machine accelerates, the water is churned around in the casing, causing the motor to load up as it approaches full speed, when, with pumps of the usual design, it takes from 40 to 50 per cent of full-load torque to drive it even though pumping no water.

Shunt-wound, direct-current motors and either squirrel-cage or phase-wound induction motors are well adapted for this type of pump and will readily meet the above conditions. A synchronous motor may lead to difficulties unless precautions are taken in designing the squirrel-cage starting winding with a sufficiently low resistance so that it will develop enough torque to pull the motor into synchronism. When this is done, however, the starting current is increased and a compromise must usually be made.

**Fans.**—Either direct- or alternating-current motors can be used for driving fans. Where the air-supply must be regulated, such as in mines, the motors must be of the adjustable-speed type. Direct-current motors may be either of the shunt- or compound-wound type, the speed regulation being accompanied by field control. Shunt-wound motors are generally used, but compound-wound motors are preferable for very large fans requiring a great starting torque.

With an alternating-current system, the phase-wound induction motor should be used, the speed regulation being accomplished by inserting resistance in the secondary rotor circuit.

**Air Compressors.**—Air compressors may be divided in two classes, centrifugal and reciprocating. The former require a high speed for their operation, while the speed of the latter is comparatively low.

Shunt-wound, direct-current motors and both squirrel-cage and phase-wound induction motors are used for driving them, the phase-wound type being preferable for larger units, where a low starting current is desirable.

With direct-current systems, shunt-wound motors are usually used for centrifugal compressors and compound-wound for the reciprocating type.

**Hoists** (E. A. Lof, in *Coal Age*).—The two principal classes of electric mine-hoist equipments are: The direct-current motor operated from its own motor-generator set by generator field control, and the induction motor. The direct-current motor lends itself well to direct connection, as the characteristics of slow-speed motors of this type are excellent. The cost of a direct-connected motor will, in practically all cases, be higher than that of a geared motor, but in some instances this is largely offset by the saving in gearing, etc. Where, however, a considerable saving can be made by using a geared motor, and where the mechanical advantages of a direct-connected hoist are not an important consideration, a geared direct-current motor should be employed. Such a motor should be separately excited and shunt-wound, and the current should be obtained from a separately excited generator of similar type, both machines being driven by a direct-coupled induction motor where the source of supply is alternating current, as is almost invariably the case.

The control of the hoist motor is effected by regulating and reversing the exciting current of the direct-current generator, thus varying the voltage impressed upon the motor terminals. The current for the motor and dynamo fields is supplied from the direct-connected exciter, and in



the case of the motor it is maintained constant. As the rapidity of hoisting is practically proportional to the voltage impressed upon the motor armature, the controlling gear is arranged so that the speed will be directly proportional to the distance by which the controlling lever is moved away from the neutral position. This system of hoisting has the great advantage that the rheostatic losses are reduced to a minimum and that the operator has perfect control over the motor.

In many cases it is highly desirable to reduce the instantaneous peak loads and equalize the current input to the hoist. This is especially true where the power charge is based wholly or partly on the maximum demand, and any practicable method, therefore, by which energy may be taken from the line and stored during periods of light load and discharged when the hoist load is heavy, makes it possible to greatly reduce the maximum input and consequently the charge for power.

The simplest method of effecting this is by adding a fly-wheel to the motor-generator set, previously described. In order to permit the fly-wheel to take care of the peaks, and equalize the load, the speed of the set must be varied according to the demand for power. This is accomplished by an automatic slip regulator connected in the secondary circuit of the induction motor, which, in this case, must be of the phase-wound type.

The second important class of electric hoisting systems is, as previously stated, driven by induction motors. Excessive low-speed motors of this type and of moderate capacities do not show particularly good electrical characteristics. For large-capacity hoists at high-rope speeds, using as small a drum diameter as is consistent with good practice, a direct-connected induction motor is, in some instances, entirely feasible, and a number of such equipments are in actual operation abroad. However, the great majority of induction-motor-driven hoists now in use and which will be installed in the future are and will continue to be of the geared type.

The induction motor must be of the phase-wound type, and the speed control is accomplished by cutting in or out resistance in the secondary circuit. Drum controllers with grid resistances are used up to about 200 horse-power, while between this and 400 horse-power it is customary to provide a complete magnetic-contactor control. Above 400 horse-power the liquid rheostat is usually employed as a secondary resistance and control.

For equalizing the load taken by an induction-motor-driven hoist, a fly-wheel motor balancer may be used. This consists of a shunt-wound or compound-wound direct-current motor, connected to a heavy fly-wheel and carrying a direct-connected exciter. The motor balancer is floated indirectly across the incoming line circuit, being tied in by means of a rotary converter or motor-generator set. A regulator actuated by the line current controls the direct-current motor field, so that when the power taken by the hoist drops below the average, the field is automatically reduced, causing the fly-wheel set to speed up and absorb power from the supply system and store it in the fly-wheel. When the load on the hoist motor exceeds the average, the operation is reversed, the fly-wheel set slows down, and power is returned to the system through the rotary converter.

**Machine Tools** (Abstracted from C. Fair, *General Electric Review*, 1914).—In general, the most satisfactory electrical equipment for machine shops, using a large number of motors, would be one having available both A.C. and D.C. distribution; A.C. for all constant speed machines and D.C. for adjustable speed machines.

In the smaller shops, with rare exceptions, the choice of motors would depend upon the current available, which in the majority of cases would be alternating current. The size and product of the small factory make a proper layout a comparatively simple matter, while in larger factories skill and ingenuity are essential to obtain the most advantageous equipment. The standard motor of to-day will answer for the majority of the machine tools, although special motors are in some cases necessary.

When equipping tools with individual drives, the controlling apparatus as well as the motor should be attached directly to the tool whenever possible. In the case of portable tools this, of course, is a necessity.

A graphic recording wattmeter in circuit with a tool is of value in efficient management, as it not only tells the actual power consumed by

the machine, showing whether or not the tool is properly motored, but it also shows whether the tool is operating at its maximum rate, by registering the time of unproductive cycles or the length of time the tool is idle. By analysis, the cause of the lost time may be discovered and a change of operating conditions can be made with a corresponding increase in production.

**Motors for Machine Tools.**

Tool.	D. C.		A. C.	
	Shunt.	Comp.	*	†
Bolt cutter . . . . .	√		*	....
Bolt and rivet header . . . . .	....	{ 20% 40%	* ....	† ....
Bulldozers . . . . .	....	{ 20% 40%	.... ....	† ....
Boring machines . . . . .	√		*	....
Boring mills . . . . .	√		*	....
Raising and lowering cross rails on boring mills and planers . . . . .	**	20%	....	†
Boring bars . . . . .	√		*	....
Bending machines . . . . .	....	{ 20% 40%	* ....	† ....
Bending rolls . . . . .	**	{ 20% 50% 20%	.... .... *	† † †
Corrugating rolls . . . . .	....	{ 50%	....	....
Centering machines . . . . .	√		*	....
Chucking machines . . . . .	√		*	....
Boring, milling and drilling machines . . . . .	√		*	....
Drill, radial . . . . .	√		*	....
Drill press . . . . .	√		*	....
Grinder—tool, etc. . . . .	√		*	....
Grinder—castings . . . . .	√	20%	*	....
Gear cutters . . . . .	√	20%	*	....
Hammers—drop . . . . .	....	{ 20% 40%	....	†
Keyseater—milling—broach . . . . .	√		*	....
Keyseater—reciprocating . . . . .	....	20%	*	....
Lathes . . . . .	√		*	....
Lathe carriages . . . . .	**	50%	....	†
Milling machines . . . . .	√		*	....
Heavy slab milling . . . . .	√	20%	*	....
Pipe cutters . . . . .	√		*	....
Punch presses . . . . .	....	{ 20% 40%	* ....	† ....
Planers . . . . .	....	{ 20% 10%	* *	† ....
Planers—rotary . . . . .	√		*	....
Saw—small circular . . . . .	√		*	....
Saw—cold bar and I-beam . . . . .	....	20%	*	....
Saw—hot . . . . .	....	20%	*	....
Screw machine . . . . .	√		*	....
Shapers . . . . .	√	10%	*	....
Shears . . . . .	....	{ 20% 40%	* ....	† ....
Slotters . . . . .	√	20%	*	....
Swaging . . . . .	....	{ 20% 40%	* ....	† ....
Tappers . . . . .	√		*	....
Tumbling barrels or mills . . . . .	....	20%	*	....

\* Squirrel cage rotor.  
 † Squirrel cage rotor—high starting torque.  
 ‡ Slip ring induction motor with external rotor resistance.  
 § Does not apply to reversing motors.  
 \*\* D. C. series motor.

The table on p. 1467 will, in a general way, aid in the choice of motors. The great variety and size of tools of the same name make it necessary in a general list, such as this, to double-check a number of tools. It must be kept in mind, however, that various circumstances, such as size and roughness of work, and fly-wheel capacity, etc., may call for radical departures in the choice of motors, this list being compiled to meet average conditions.

Shunt motors, for instance, are used in the following cases: When work is of a fairly steady nature, when considerable range of adjustment of speed is required, as on lathes and boring mills, and on group and line-shaft drives, etc.

Compound-wound motors are used where there are sudden calls for excessive power of short duration, as on planers without reversing motor drives, punch presses, bending rolls, etc.

Series motors should be used where speed regulation is not essential, and where excessive starting torque is required, as, for instance, in moving carriages of large lathes, in raising and lowering the cross rails of planers and boring mills, and for operating cranes, etc., but not where the motor can be run without load, through the opening of a clutch, or by a belt leaving its pulley, as the motor would run away if the operator failed to shut off the power.

When in doubt as to the choice of compound or series motors of small horse-power, the choice might be determined by the simplicity of control in favor of the series motor.

The alternating-current motor of the squirrel-cage rotor type corresponds to the constant-speed, shunt, direct-current motor; but with a high-resistance rotor it approaches more closely the characteristics of a compound, direct-current motor. It is understood that the variable-speed machines checked in the table above under the alternating-current squirrel-cage rotor column have the necessary mechanical speed changes.

The slip-ring induction motor with external rotor resistance would be used for variable speed, but this must not be construed to mean that it corresponds to a direct-current, adjustable-speed motor, as it has the characteristics of a direct-current shunt motor with armature control.

The self-contained, rotor resistance type could be used for lineshaft drives, and for groups when of sufficient size.

Multi-speed, alternating-current motors are those giving a number of definite speeds, usually 600 and 1200, or 600, 900, 1200, and 1800 r.p.m., and are made for both constant power and constant torque. These motors would be used where alternating current only was available, and where the speed ranges of the motor, together with one or two change gears, would give the required speeds. These motors should, however, be used with discretion, especially on sizes above six horse-power.

The adjustable speed, A.C., commutator brush-shifting type of motor with shunt characteristics would, on account of high cost, be used mostly where an adjustable speed motor was highly desirable and where A.C. only was available and where there were not enough machines calling for adjustable speed drive to warrant putting in a motor-generator set.

### ILLUMINATION—ELECTRIC AND GAS LIGHTING.\*

**Illumination.**—Some writers distinguish "lighting" and "illumination." Lighting refers to the character of the lights themselves, as dazzling, brilliant, or soft and pleasing, and illumination to the quantity of light reflected from objects, by which they are rendered visible. If the objects in a room are clearly seen, then the room is well illuminated.

The quantity of light is estimated in candle-power per square foot of area or per cubic foot of space. The amount of illumination given by one candle at a distance of 1 ft. is known as a foot-candle. Since the illumination varies inversely as the square of the distance, one foot-candle is given by a 16-candle-power lamp at a distance of 4 ft., or by a 25-c.-p. lamp at a distance of 5 ft.

**Terms, Units, Definitions.**—Quantity of light proceeding from a source of light, measured in units of luminous flux, or lumens.

Intensity with which the flux is emitted from a radiant in a single direction, called candle-power.

Illumination, density of the light flux incident upon an area.

\* Contributed by Prof. W. H. Timbie.



**Luminosity**, brightness of surface; flux emitted per unit area of surface.

**Candle-power**, the unit of luminous intensity. A spermaceti candle-burning at the rate of 120 grains per hour is the old standard used in the gas industry. It is very unsatisfactory as a standard and is being displaced by others.

The hefner lamp, burning amyl acetate, is the legal standard in Germany. The unit of luminous intensity produced by this lamp when constructed and operated as prescribed is called a *hefner*. The standard laboratories of Great Britain, France, and America have agreed upon the following relative values of the units used in the several countries: 1 International Candle = 1 Pentane Candle = 1 Bougie Decimale = 1 American Candle = 1.11 Hefners = 0.104 Carcel unit. 1 Hefner = 0.90 International Candle.

**Intrinsic Brilliancy** of a source of light = candle-power per square inch of surface exposed in a given direction.

**Lumen**, the unit of luminous flux, is the quantity of light included in a unit solid angle and radiated from a source of unit intensity. A unit solid angle is the angular space subtended at the surface of a sphere by an area equal to the square of the radius, or by  $1 \div 4\pi$ , or  $1/12.5664$  of the surface of the sphere. The light of a source whose average intensity in all directions is 1 candle-power, or one mean spherical candle-power, has a total flux of 12.5664 lumens.

**Foot-candle**, the unit of illumination, = 1 lumen per square foot; the illumination received by a surface every point of which is distant one foot from a source of one candle-power.

**Lux**, or meter-candle, 1 lumen per square meter; 1 foot-candle = 10.76 meter-candles.

**Law of Inverse Squares**.—The illumination of any surface is inversely proportional to the square of its distance from the source of light. This is strictly true when the source of light is a point, and is very nearly true in all cases when the distance is more than ten times the greatest dimension of the light-giving surface.

**Law of Cosines**.—When a surface is illuminated by a beam of light striking it at an angle other than a right angle, the illumination is proportional to the cosine of the angle the beam makes with a normal to the surface.

If  $E$  = the illumination at any point in a surface,  $I$  the intensity of light coming from a source,  $\theta$  the angle of deviation of the direction of the beam from a normal to the surface, and  $l$  the distance from the source, then  $E = I \cos \theta \div l^2$ .

**Relative Color Values of Various Illuminants**.—The light proceeding from any source may be analyzed in terms of the elementary color elements, red, green and blue, by means of the spectroscope, or by a colorimeter. The following relative values have been obtained by the Ives colorimeter (*Trans. Ill., Eng. Soc.*, iii, 631). In all cases the red rays in the light are taken as 100, and the two figures given are respectively the proportions of green and blue relative to 100 red.

Average daylight, 100, 100. Blue sky, 106, 120. Overcast sky, 92, 85. Afternoon sunlight, 91, 56. Direct-current carbon arc, 64, 39. Mercury arc (red 100), 130, 190. Moore carbon dioxide tube, 120, 520. Welsbach mantle,  $3/4\%$  cerium, 81, 28. Do.,  $1\frac{1}{4}\%$  cerium, 69, 14.5. Do.,  $1\frac{3}{4}\%$  cerium, 63, 12.3. Tungsten lamp, 1.25 watts per mean horizontal candle-power, 55, 12.1. Nernst glower, bare, 51.5, 11.3. Tantalum lamp, 2 watts per m. h. c.-p., 49, 8.3. Gem lamp, 2.5 watts per m. h. c.-p., 48, 8.3. Carbon incandescent lamp, 3.1 watts per m. h. c.-p., 45, 7.4. Flaming arc, 36.5, 9. Gas flame, open fish-tail burner, 40, 5.8. Moore nitrogen tube, 28, 6.6. Hefner lamp, 35, 3.8.

**Relation of Illumination to Vision**.—Wickenden gives the following summary of the principles of effective vision:

1. The eye works with approximately normal efficiency upon surfaces possessing an effective luminosity of one foot-candle or more.
2. Excessive illumination and inadequate illumination strain and fatigue the eye in an effort to secure sharp perception.
3. Intrinsic brilliancy of more than 5 c.-p. per sq. in. should be reduced by a diffusing medium when the rays enter the eye at an angle below  $60^\circ$  with the horizontal.

4. Flickering, unsteady, and streaky illumination strains the retina in the effort to maintain uniform vision.

5. True color values are obtained only from light possessing all the elements of diffused daylight in approximately equivalent proportions.

6. An excess of ultra-violet rays is to be avoided for hygienic reasons.

7. Æsthetic considerations commend light of a faint reddish tint as warm and cheerful in comparison with the cold effects of the green tints, although the latter are more effective in revealing fine detail.

**Types of Electric Lamps.**—The carbon arc lamp is now rapidly disappearing on account of the cost of maintenance of the open type and the low efficiency of the enclosed type. Gas-filled tungsten lamps now operate at less cost on the same circuits on which these arcs formerly burned.

*The Flaming Arc.*—The carbons are impregnated with calcium fluoride or other luminescent salts. The current is usually 8 to 12 amperes and the voltage per lamp 35 to 60. The regenerative flame arc is a highly efficient variety of the flame arc.

*The Magnetite Arc* has for a cathode a thin iron tube packed with a mixture of magnetite,  $\text{Fe}_3\text{O}_4$ , and titanium and chromium oxides. The anode consists of copper or brass. It is well adapted to series operation with low currents. The 4-ampere lamp, using 80 volts per lamp, is highly successful for street illumination.

*The Tungsten Incandescent (vacuum)* depends upon the heating of a drawn tungsten filament to incandescence in a vacuum. They are made in sizes for 25, 40, 60, 100, 150, 250, 400, 500, 750, and 1000 watts and average about 1 candle-power for each watt, with a life of 1000 hours, before the candle-power falls below 80% at rated voltage.

*The Tungsten Incandescent (gas-filled)* has the advantage of having longer life and being smaller than the vacuum lamp of the same wattage. They are filled with an inert gas, generally nitrogen or argon, and have an efficiency of 2 candle-power per watt in the larger sizes (the average being about 1.7 candle-power per watt), with a life of 1300 hours.

*The Mercury Vapor Lamp* is an arc of luminous mercury vapor contained in a glass tube from which the air has been exhausted. A small quantity of mercury is contained in the tube, and platinum wires are inserted in each end. When the tube is placed in a horizontal position so that a thin thread of mercury lies along it, making electrical connection with the wires, and a current is passed through it, part of the mercury is vaporized, and on the tube being inclined so that the liquid mercury remains at one end, an electric arc is formed in the vapor throughout the tube. The tubes are made about one inch in diameter and of different lengths, as below. The mercury vapor lamp is very efficient, ranging from 1.9 c.-p. per watt for the 900 c.-p. size to 1.55 c.-p. per watt for the 300 c.-p. size. The color of the light is unsatisfactory, being deficient in red rays, but it possesses a very penetrating quality which makes it valuable in drafting rooms and wherever a light is needed to bring small details out sharply. The spectrum consists of three bands, of yellow, green, and violet, respectively. The intrinsic brilliancy of the lamp is very moderate, about 17 c.-p. per sq. in. Commercial lamps are made of the sizes given below. The lamp is essentially a direct-current lamp, but it may be adapted to alternating-current by use of the principle of the mercury-arc rectifier. The tubes have a life ordinarily of about 1000 hours.

*The Quartz-Tube Mercury-Arc Lamp* operates at a higher voltage and gives much nearer a white light. Owing to the injurious ultra-violet rays given out by this form, it must always be enclosed in a globe of clear glass. The efficiency ranges from 2.4 to 3.3 c.-p. per watt and the life averages 3000 hours. It is made in sizes from 1000 to 3500 c.-p.

**Street Lighting.**—Street lighting may be divided into three classes:

- (a) "White-Way" or display illumination.
- (b) Main road illumination.
- (c) Residence district lighting.

The object of "White-Way" illumination is generally advertising and many more lights are used than are necessary for proper road illumination. The lamps generally used are the titanium arc, the magnetite

arc, the yellow flaming arc, and the white flaming arc of over 1000 c.-p. See last column of Table VI.

In "Main-road" illumination the purpose is to illuminate the road appreciably for night automobile travel. The lamps generally used are some type of the 300-watt flaming arc, the magnetite arc, or the titanium arc of Table IV. These are usually placed from 200 to 300 ft. apart at heights varying from 15 to 18 ft.

For Residential-district Lighting, where vehicle travel is infrequent and slow, the smaller sizes (40 to 100 c.-p.) of tungsten lamps are used spaced from 100 to 200 ft. at height varying from 15 to 18 ft. according to shading of the road by the foliage. Tungsten lamps of the higher candle-powers of 200 to 450 are also used with spacings of 200 ft. and over, with reflectors designed to give the best distribution of the light.

**Illumination by Arc Lamps at Different Distances.**—Several diagrams and curves showing the light distribution in a vertical plane and the illumination at different distances of different types of lamps are given by Wickenden. From the latter are taken the approximate figures in the table below. The carbon and the magnetite lamps were 25 ft. high, the flame arcs 21 ft.

TABLE I.—Illumination by Arc Lamps.

Horizontal Distance from Lamp, Feet.	20	30	40	50	100	150	200	250
Kind of Lamp.	Foot-candles, normal illumination.							
A. Open carbon arc, D.C., 6.6 amp.	....	0.40	0.29	0.20	.032	.014	.006	.002
B. Enclosed carbon arc, A.C. 6.6	0.30	0.19	.135	0.10	.027	.013	.006	.002
C. Flame arc, 10 "	....	....	....	1.10	.31	.14	.08	.05
D. Regenerative arc, 7 "	....	....	0.85	0.65	.15	.055	.03	.02
E. Magnetite arc, 6.6 "	....	1.00	0.69	0.51	.15	.075	.045	.025
F. Magnetite arc, 4 "	0.47	0.40	0.30	0.21	.07	.035	.022	.018

A. 6.6 amp., D.C., open arc, clear globe.

B. 6.6 amp., A.C., enclosed arc, opal inner and clear outer globe, small reflector.

C. 10 amp., flame arc, vertical electrodes; 50 volts, 1520 M.L.H.C.-P.\*; 0.33 watt per M.L.H.C.-P.\*; 10 hours per trim.

D. 7 amp., regenerative flame arc, 70 volts, 2440 M.L.H.C.-P., 0.2 watt per M.L.H.C.-P., 70 hours per trim.

E. 6.6 amp., D.C. series magnetite arc, 79 volts, 510 watts, 1450 M.L.H.C.-P. 75 to 100 hours per trim.

F. 4 amp., D.C. series magnetite arc, 80 volts, 320 watts, 575 M.L.H.C.-P., 150 to 200 hours per trim.

TABLE II.—Data of Some Arc Lamps.

Type of Lamp.	Hours per Trim.	Am-peres.	Ter-minal Volts.	Ter-minal Watts.	Watts per M.L.H.C.-P.
D.C. series carbon, open . . . . .	9 to 12	9.6	50	480	0.6
D.C. series carbon, enclosed . . . . .	100 to 150	6.6	72	475	0.9
A.C. series carbon, enclosed . . . . .	70 to 100	7.5	75	480	1.25
D.C. multiple carbon, enclosed . . . . .	100 to 150	5.0	110	550	2.25
A.C. multiple carbon, enclosed . . . . .	70 to 100	6.0	110	430	2.40
D.C. flame arcs, open . . . . .	10 to 16	10	55	440	0.45
Regenerative, semi-enclosed . . . . .	70	5	70	350	0.26
A.C. flame arcs, open . . . . .	10 to 16	10	55	467	0.55
Magnetite, open . . . . .	70 to 100	6.6	80	528	0.45

Values of watts per M.L.H.C.-P. approximate for open carbon arcs and magnetite arcs with clear globes, enclosed arcs with opalescent inner and clear outer globes, and for flame and regenerative arcs with opal globes.

\* M.H.C.-P. = mean horizontal candle-power;

M.L.H.C.-P. = mean lower hemispherical candle-power.



**Relative Efficiency of Illuminants.**—The advent of the gas-filled tungsten incandescent lamp of high efficiency and high candle-power has driven the less efficient arc lamps from the field. At present (1915) the incandescent lamp of the 200- or 300-watt size is more efficient than the arc lamp of the same candle-power. On the other hand, the 1000-c.-p. arcs are more efficient than the incandescent lamps of the same size. The field for the arc lamp seems to be in the higher candle-power sizes. Dr. Steinmetz in *The General Electric Review* for March, 1914, gives the following tables.

**TABLE III.—Relative Efficiency of Illuminants.**

(Irrespective of Size, in Available Mean Spherical C.-P. per Watt).

	Available Mean Spherical C.-P. per Watt.	(Street Lighting) 10° C.-P.* per Watt	Available Mean Spherical C.-P.
3.1 watt per h. c.-p. carbon filament....	0.21	0.4	Any
2.5 watt per h. c.-p. gem filament.....	0.26	0.5	Any
450 watt 6.6 amp. series enclosed a.c. carbon arc.....	0.39	0.5	175
Nitrogen Moore tube.....	0.45	.....	.....
480 watt 6.6 amp. series enclosed d.c. carbon arc.....	0.62	1.0	300
1 watt per h. c.-p. mazda lamp.....	0.64	1.25	Any
500 watt d.c. "intensified" carbon arc...	0.78	.....	.....
4 amp. 300 watt d.c. special magnetite arc	1.0	2.2	300
Neon Moore tube.....	1.1	.....	.....
0.5 watt per h. c.-p. gas-filled mazda lamp	1.28	2.5	Above 350
4 amp. 300 watt d.c. special magnetite arc	1.4	3.0	(420)
6.6 amp. 500 watt d.c. standard magnetite arc.....	1.5	3.2	750
Mercury lamp in glass tube, best values. 6.6 amp. 500 watt d.c. special magnetite arc.....	1.55	.....	.....
.....	1.7	3.6	850
220 watt a.c. titanium arc.....	1.9	4.0	420
300 watt yellow flame arc, best value....	1.95	4.0	(585)
500 watt white flame arc, best values....	1.95	4.0	(975)
Mercury lamp in quartz tube, best values	2.0	.....	.....
Exper. 350 watt a.c. titanium arc.....	2.7	5.4	(950)
Melting tungsten in vacuum.....	2.88	.....	.....
500 watt yellow flame arc, best value....	3.1	6.2	(1550)
Exper. 500 watt a.c. titanium arc.....	3.6	7.0	(1800)
Titanium arc, best values (high power) ..	5.2	.....	.....

\*The expression 10° c.-p. per watt means the candle-power per watt on a circle 10° below the horizontal plane of the filament.

**TABLE IV.—Efficiency of 300-Watt Illuminants.**

	Available Mean Spherical C.-P. per Watt.	Available Mean Spherical C.-P.
Mazda lamp (1 watt per h. c.-p.).....	0.64	190
Standard 4 amp. d.c. magnetite arc.....	1.0	300
White flame carbon arc, best.....	1.2	360
Gas-filled mazda lamp (0.5 watt per h. c.-p.).....	1.28	384
Special 4 amp. d.c. magnetite arc.....	1.4	420
Yellow flame carbon arc, best.....	1.95	585
A.C. titanium arc.....	2.4	720

TABLE V.—Efficiency of 500-Watt Illuminants.

	Available Mean Spherical C.-P. per Watt.	Available Mean Spherical C.-P.
A.C. series enclosed carbon arc.....	0.42	210
Mazda lamp (1 watt per h. c.-p.).....	0.64	320
D.C. series enclosed carbon arc.....	0.65	325
Gas-filled mazda lamp (0.5 watt per h. c.-p.) .....	1.28	640
Standard 6.6 amp. d.c. magnetite arc.....	1.5	750
Special 6.6 amp. d.c. magnetite arc.....	1.7	850
White flame carbon arc, best.....	1.95	975
Quartz mercury lamp.....	2.0	1000
Yellow flame carbon arc, best.....	3.1	1550
A.C. titanium arc.....	3.6	1800

**Characteristics of Tungsten Lamps.** Vacuum Type.—The accompanying Table VII refers to tungsten lamps of the 25, 60, and 100 watt size. They show the changes which take place in the candle-power, watts, watts per candle-power and life when used at the various voltages. It is to be noted that a 4% increase in voltage above the normal (100%) increases the candle-power 15%, the efficiency 6%, but decreases the life 38%.

TABLE VI.—Relative Efficiency of Various C.-P. of Illuminants.

200 Mean Spherical C.-P.		300 Mean Spherical C.-P.		400 Mean Spherical C.-P.		500 Mean Spherical C.-P.		1000 Mean Spherical C.-P.	
Type.	Watt.	Type.	Watt.	Type.	Watt.	Type.	Watt.	Type.	Watt.
A.C. carbon.....	490	A.C. carbon.....	620	Mazda....	620	Standard magnetite..	400	Gas-filled mazda.....	780
D.C. carbon.....	380	D.C. carbon.....	480	Standard magnetite..	350	Gas-filled mazda.....	390	Standard magnetite..	700
Mazda.....	310	Mazda.....	470	Gas-filled mazda.....	310	Special magnetite..	350	Special magnetite..	550
.....		Standard magnetite	300	Special magnetite..	290	White Flame.....	350	White Flame.....	520
.....		Special magnetite..	250	Titanium..	210	Yellow Flame.....	280	Yellow Flame.....	400
.....		.....		.....		Titanium..	250	Titanium..	360

**Interior Illumination.**—There are three systems for artificially lighting interiors. All three are easily adapted for the use of either gas or electricity or both: (1) Direct lighting; (2) indirect lighting; (3) semi-indirect lighting.

(1) *Direct Lighting.*—When the room is illuminated almost entirely by the light which comes directly from the lamps without reflection from walls and ceilings, it is said to be illuminated by direct lighting. This is the usual form of lighting.

(2) *Indirect Lighting.*—When a room is illuminated by the light of concealed lamps which is reflected from the walls and ceiling, the system of illumination is said to be indirect. The ceiling and walls must be light-colored. There is an entire lack of shadows in a room thus lighted.

(3) *Semi-indirect Lighting.*—When a room is illuminated mostly by light reflected from the walls and ceiling but still receives 15 or 20% directly from the lamps, the system of illumination is said to be semi-indirect. This system produces particularly pleasing effects.

**The Quantity of Electricity and Gas Necessary to Illuminate Various Rooms.**—Practically all modern illumination is done either by tungsten incandescent electric lamps or gas lamps with incandescent mantles.

TABLE VII.—Characteristics of Mazda (Vacuum) Lamps.

Per Cent of Rated Voltage.	Per Cent of Rated C.-P.	Per Cent of Rated Watts.	Efficiency in C.-P. per Watt.	Life in Per Cent of Rated Life.	Per Cent of Rated Amperes.	Per Cent of Rated Ohms.	Per Cent of Rated Voltage.	Per Cent of Rated C.-P.	Per Cent of Rated Watts.	Efficiency in C.-P. per Watt.	Life in Per Cent of Rated Life.	Per Cent of Rated Amperes.	Per Cent of Rated Ohms.
50	8	33	.....	.....	67	77	102	108	103	0.934	80	.....	.....
60	15	44	0.231	.....	72	80	104	115	106	0.971	62	.....	.....
70	27	57	0.429	.....	82	87	106	123	110	1.01	48	103	102
75	36	63	0.500	.....	84	88	108	130	113	1.03	35	.....	.....
80	45	71	0.578	.....	88	92	110	139	117	1.08	25	106	104
85	57	77	0.658	.....	91	94	115	161	125	1.16	.....	108	106
90	69	85	0.736	.....	94	96	120	187	133	1.27	.....	112	108
92	75	88	0.769	.....	.....	.....	125	213	142	1.35	.....	114	110
94	81	91	0.799	230	96	98	130	242	.....	1.47	.....	117	112
96	87	94	0.833	180	.....	.....	140	.....	.....	1.67	.....	122	115
98	93	97	0.880	135	.....	.....	150	.....	.....	1.85	.....	127	118
100	100	100	0.909	100	100	100	.....	.....	.....	.....	.....	.....	.....

The following table of electricity and gas necessary to light rooms used for given purposes is based on the fact that in the modern mazda lamps 1.1 watt produces 1 c.-p., and in the best gas lamps with incandescent mantles, 0.04 cu. ft. per hour of gas produces 1 c.-p. Inasmuch as there are no bright spots in the room to fatigue the eye, when indirect and semi-indirect systems are used, a lower degree of illumination is sufficient to enable objects to be clearly seen. Hence, although the indirect and semi-indirect systems are less efficient, the following table applies to all these methods:

TABLE VIII.—Electricity or Gas Necessary to Sufficiently Illuminate Rooms.

Use of Rooms.	Watts per Sq. Ft. of Working Plane.	Cu. Ft. per Hour per Sq. Ft. of Working Plane.	Use of Rooms.	Watts per Sq. Ft. of Working Plane.	Cu. Ft. per Hour per Sq. Ft. of Working Plane.
Assembly hall....	0.8-0.1	0.032-0.04	Library (book stacks).....	0.3-0.6	0.012-0.24
Ball room.....	1.2-1.3	0.05 -0.052	Library (residence).....	1.0-1.1	0.04 -0.044
Barber shop.....	1.5-1.7	0.06 -0.07	Lobby (hotel)...	1.5-1.6	0.06 -0.065
Bed room (residence).....	0.3-0.35	0.012-0.014	Machine shop...	2.0-2.2	0.08 -0.088
Class room (school).....	1.2-1.3	0.048-0.052	Music room (residence).....	0.5-0.6	0.02- 0.025
Corridor.....	0.4-0.5	0.016-0.02	Office (banking and accounting)...	1.5-1.6	0.06 -0.065
Dining room (residence).....	0.9-1.0	0.036-0.04	Office (general)...	1.3-1.5	0.052-0.06
Drafting room...	2.5-2.8	0.10 -0.112	Operating room (hospital).....	3.5-3.9	0.14 -0.15
Drill hall.....	0.5-0.6	0.02 -0.025	Restaurant.....	1.5-1.7	0.06 -0.07
Foundry.....	3.0-4.0	0.12 -0.16	Store.....	1.4-1.7	0.055-0.07
Kitchen.....	1.2-1.3	0.05 -0.052	Warerooms.....	0.3-0.9	0.012-0.030
Library (public reading room)...	1.4-1.5	0.055-0.06	Wood-working shop.....	1.5-1.8	0.06 -0.072

For gas-filled tungsten and Welsbach "Kinetic" use 0.6 of above values. Data on gas furnished by F. R. Pierce, Welsbach Co.



**Example of Use of Table VIII.**

Specify the proper lighting arrangements for a banking office 25 ft. × 40 ft. with a 13-ft. ceiling.

The four-lamp fixture is an efficient and pleasing arrangement of lamps. It does not give quite as uniform distribution of light as individual lamps uniformly spaced, but the effect is much more pleasing and the distribution is very satisfactory.

*Using Electricity.*—

$$\begin{aligned} \text{Watts per sq. ft. needed} &= 1.5 - 1.6 \text{ (Table VIII).} \\ \text{Total watts needed} &= 1.5 \times 40 \times 25. \\ &= 1500 \text{ watts.} \end{aligned}$$

Using four-lamp fixtures, we shall need six fixtures, as in Fig. 250, in two rows of 3 each.

$$\text{Watts per fixture} = \frac{1500}{6} = 250.$$

$$\text{Watts per lamp} = \frac{250}{4} = 62.5.$$

On consulting Table IX we find we can use 60-watt lamps as the standard lamp nearest the size computed. If at any place more light is needed, 100-watt lamps may be substituted in the nearest fixture.

*Using Gas.*—To use gas with the same number of similar fixtures, we would have to use lamps which correspond to the 60-watt mazda.

Allowing 25 watts to the cu. ft. per hour of gas, we would need a lamp which would burn  $\frac{60}{25}$  or 2½ cu. ft.

per hour of gas. By Table IX, we see that this is a standard size.

The foregoing rules are merely intended to serve as a guide for planning correct illumination. They

are not intended to take the place of judgment and intelligence. The details of each lighting project differ slightly from the details of every other lighting project and due weight should be given to ways in which these details affect the application of general rules.

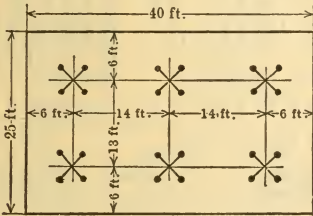

FIG. 250.

**TABLE IX.—Standard Units; Mazda and Welsbach.**

Watts (105-125 Volts).	C.-P. per Watt.	Welsbach Inverted.		Watts (105-125 Volts).	C.-P. per Watt.	Welsbach Inverted.		Welsbach Upright.	
		Cu. Ft.	Equiv. Watts per Hour.			Cu. Ft.	Equiv. Watts per Hour.	Cu. Ft.	Equiv. Watts per Hour.
10	0.77	.....	.....	150	1.11	.....	.....	.....	.....
15	0.80	.....	.....	250	1.11	10	250	.....	.....
20	0.855	.....	.....	400	1.33	.....	.....	.....	.....
25	0.88	.....	.....	500	1.43	.....	.....	.....	.....
40	0.91	1.6	40	750	1.67	.....	.....	.....	.....
60	0.935	2.5	62.5	1000	1.82	.....	.....	.....	.....
100	0.98	4.0	100	.....	.....	.....	.....	.....	.....
.....	.....	4.5	112.5	.....	.....	.....	.....	5.5	135.5

**Cost of Electric Lighting.** (A. A. Wohlauer, *El. World*, May 16, 1908, corrected, July, 1915.)—The following table shows the relative cost of 1000 candle-hours of illumination by lamps of different kinds, based on costs of 2, 4 and 10 cents per Kw.-hour for electric energy. The life, K, is that of the lamp for incandescent lamps, of the electrode for arc lamps, and of the vapor tube for vapor lamps.

$L_s$  = mean spherical candle-power.

$S_s$  = watts per mean spherical candle.

$P$  = renewal cost per trim or life, cents.

$K$  = life in hours.

$C_r$  = 1000  $P / (KL_s)$ .

$C_t = (S_s \times R) + C_r = \text{cost}^* \text{ per 1000 candle-hours.}$

$R$  = rate in cts. per K.W. hour.

Illuminant.	Amp.	Volts.	$L_s$	$S_s$	$P$	$K$	$C_r$	Rating.	$C_t = \frac{(S_s \times R)}{+ C_r}$		
Incandescent Lamps.									R=2	4	10
Carbon.....	0.31	110	13.2	3.8	16	450	2.7	16 c.-p.	10.3	17.9	40.7
Gem.....	0.45	110	16.5	3.05	20	450	2.7	20 c.-p.	8.8	14.9	33.2
Tungsten.....	0.91	110	72	1.4	70	1000	0.97	100 Watt	3.8	6.6	15.0

#### Direct-Current Arc Lamps.

Open arc.....	10	55	400	1.3	8	10	2	10 amp.	4.6	7.2	15
Enclosed.....	5.0	110	260	2.1	9	150	0.2	5	4.4	8.6	21.2
Carbon.....	10	110	550	2.0	8	16	1	10	5	9	21
Miniature.....	2.5	110	150	1.8	6	20	2	2.5	5.6	9.2	20
Magnetite.....	3.5	110	225	1.7	10	150	0.31	3.5	3.71	7.11	17.3
Flaming.....	10	55	600	0.75	17	10	2.4	10	3.9	5.4	9.9
Inclined flaming.....	10	55	1100	0.5	18	10	1.6	10	2.6	3.6	6.6
Inclined enclosed flaming	5.5	100	1500	0.365	30	70	0.1	5.5	1.03	1.76	4

#### Mercury-Vapor Lamps.

Cooper Hewitt	3.5	110	770	0.5	1200	4000	0.4	3.5 amp.	1.4	2.4	5.4
Quartz.....	3.5	220	1300	0.6	700	3000	0.135	3.5	1.34	2.54	6.14

#### Recent Street Lighting Installations.

(Preston S. Millar, *Proc. A. I. E. E.*, July, 1915).

City.	Width, Roadway, Ft.	No. of Lighting Units.	Linear Spacing, Ft. <sup>4</sup>	Height in Feet.	Kind of Buildings. <sup>5</sup>	Location of Lamps. <sup>6</sup>	Kind of Mount. <sup>9</sup>	Lamps. <sup>10</sup>	Globes <sup>11</sup> .
1	36	50	80	18	B	O	K	D.C., 6.6 amp. LA.	A
2	47	90	69	24	.....	S	P	A.C., SF.	B
3	42	102	94	25	B	S	P	A.C., SF.	B
4	80	222	100	14.5	B	O	P	6.6 amp. Mag.	A
5	90 <sup>1</sup>	82	112	14	B	S	P	600 c.-p. Mazda C.	N
6	109	123		15	A	S	P	6.6 amp. Mag.	A
7	60	200 <sup>3</sup>	100	19	B	S	P	120v., 400w M.C.	C
8	.....	.....	100	13.5	B	O	P	400 c.-p., 15 amp. M.C.	R
9	50	56	400	17.5	R	S	P	1000 c.-p. M.C.	A
10	92	.....	92	19.8	B	O	K	4.0 amp. D.C. LA.	A
11	80	79	105	22	Ap.	note <sup>7</sup>	P	120v., 400w., M.C.	C
12	36	.....	220	22	R	note <sup>8</sup>	P	600 c.-p. M.C.	B
13	50 <sup>2</sup>	246	120	10.25	R	S	P	5.5 amp. series M.C.	B

(NOTES.)—<sup>1</sup> Between building lines. <sup>2</sup> 160 ft. between building lines.  
<sup>3</sup> Two per post. <sup>4</sup> Along one curb. <sup>5</sup> Kind of buildings: B, business structures; A, all kinds; Ap., apartments; R, residences. <sup>6</sup> O, both curbs, opposite; S, staggered. <sup>7</sup> In center of block (on center isle). On curb of intersecting streets at house line of cross-street intersection.  
<sup>8</sup> East curb only. <sup>9</sup> K, brackets on trolley poles; P, ornamental posts.

<sup>10</sup> LA, luminous arc; SF, series flame arc; Mag., inverted magnetite; M.C., Mazda C. <sup>11</sup> A, alabaster; B, alba; N, novulux; C, Carrara; R, C.R.I., globe and translucent glass reflectors.

*Cities.*—1. 5th Ave., Pittsburgh; 2. Federal St., Pittsburgh; 3. Dearborn St., Chicago; 4. Main St., Rochester, N. Y.; 5. Main St., Hartford, Conn.; 6. Penna. Ave., Washington, D. C.; 7. 5th Ave., New York; 8. Market St., Corning, N. Y.; 9. Lake Ave., Rochester; 10. Grand Ave., Milwaukee; 11. 7th Ave., New York; 12. Troy St., Chicago; 13. 16th St., Washington.

## SYMBOLS USED IN ELECTRICAL DIAGRAMS.

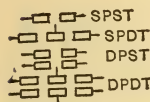

Galvanometer.



Ammeter.



Voltmeter.

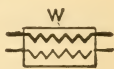

Wattmeter.

Switches; *S*, single;  
*D*, double; *P*, pole;  
*T*, throw.

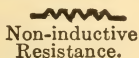
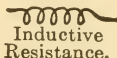
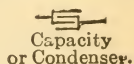
Non-inductive  
Resistance.Inductive  
Resistance.Capacity  
or Condenser.

Lamps.

Motor  
or Generator.Shunt-wound Motor  
or Generator.Series-wound  
Motor or Generator.Two-phase  
Generator.Three-phase  
Generator.

Battery.

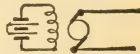
Trans-  
former.Compound-  
wound Motor  
or Generator.Separately  
excited Motor  
or Generator.





## INDEX.

---

### ABBREVIATIONS, 1

Abrasion, resistance to, of manganese steel, 495  
Abrasive processes, 1309-1318  
Abrasives, artificial, 1313  
Abscissas, 70  
Absolute temperature, 567  
    zero, 567  
Absorption of gases, 605  
    of water by brick, 370  
    refrigerating machines, 1346, 1364  
Accelerated motion, 526  
Acceleration, definition of, 521, 526  
    force of, 526  
    rates of, on electric railways, 1415  
    work of, 529  
Accumulators, electric, 1425  
Acetylene and calcium carbide, 855  
    blowpipe, 857  
    flame welding, 488  
    generators and burners, 857  
    heating value of, 856  
Acheson's deflocculated graphite, 1246  
Acme screw thread, 234  
Adhesion between wheels and rails, 1416  
Adiabatic compression of air, 633  
    curve, 959  
    expansion, 601  
    expansion in compressed air-engines, 638  
    expansion of air, 635, 638  
    expansion of steam, 959  
Admiralty metal, composition of, 390  
Admittance of alternating currents, 1441  
Aerial tramways, track cable for, 260  
**Air** (*see also* Atmosphere), 606-681  
    and vapor mixture, weight of, 610-613  
    -bound pipes, 748  
    carbonic acid allowable in, 681, 685  
    compressed, 623, 632-653  
    (*see* Compressed air)  
**Air Compressors**, centrifugal, 648  
    effect of intake temperatures, 647  
    electric motors for, 1465

Air compressors, high altitude, table of, 639  
    hydraulic, 650  
    intercoolers for, 648  
    steam consumption of, 644  
    tables of, 641-643  
    tests of, 643  
**Air**, contamination of, 687  
    cooling of, 594, 710  
    density and pressure, 607, 613  
**Air, flow of**, in pipes, 617-624  
    in long pipes, 618-624  
    in ventilating ducts, 683  
    through orifices, 615-617, 670  
**Air**, friction of, in underground passages, 714  
    head of, due to temperature differences, 716  
    heating of (*see also* Heating)  
    heating, heat-units absorbed in, 691  
    heating of, by compression, 632  
    horse-power required to compress, 637  
    in feed-pump discharges, 1074  
    inhaled by a man, 687  
    leaks in steam boilers, 891  
    -lift pump, 808  
    -lift pump for oil wells, 809  
    liquid, 605  
    loss of pressure of, in pipes, 617-624  
    manometer, 607  
    pipes in house heating, capacity of, 691  
    pressures, conversion table for, 607  
    properties of, 606  
    -pump, 1071-1073  
    -pump for condenser, 1071, 1073  
    -pump, maximum work of, 1074  
    pyrometer, 555  
    saturated, temperatures, pressures and volume, table, 1072  
    saturated, volume at different vacuums, 1072  
    specific heat of, 564  
    thermometer, 557  
    velocity of, in pipes, by anemometer, 624  
    volume at different temperatures, 692  
    volume transmitted in pipes, table, 623, 624

- Air**, volumes, densities, and pressures, 607, 613  
 washing, 687  
 water vapor in 1 pound of, 1081  
 weight and volume of, 27  
 weight of, 176  
 weight of (table), 609, 613
- Alcohol as fuel**, 843  
 denatured, 843  
 engines, 1102  
 vapor tension of, 844
- Alden absorption dynamometer**, 1334
- Algebra**, 33-37
- Algebraic symbols**, 1
- Alligation**, 9
- Alloy steels**, 470-480 (*see* Steel)
- Alloys**, 384-410  
 aluminum, 396-399  
 aluminum-antimony, 399  
 aluminum-copper, 396  
 aluminum-silicon-iron, 398  
 aluminum, tests of, 398  
 aluminum-tungsten, 399  
 aluminum-zinc, 399  
 antimony, 405, 407  
 bearing metal, 405  
 bismuth, 404  
 caution as to strength of, 398  
 composition by mixture and by analysis, 388  
 composition of, in brass foundries, 390  
 copper-manganese, 401  
 copper-tin, 384  
 copper-tin-lead, 394  
 copper-tin-zinc, 387-390  
 copper-zinc, 386  
 copper-zinc-iron, 393  
 ferro-, 1255  
 ferro-, manufacture of, 1424  
 for casting under pressure, 395  
 fusible, 404  
 Japanese, 393  
 liquation of metals in, 388  
 magnetic, of non-magnetic metals, 402  
 miscellaneous, analyses and properties, 392  
 nickel, 402  
 the strongest bronze, 389  
 vanadium and copper, 395  
 white metal, 407
- Alternating currents**, 1440-1460  
 admittance, 1441  
 average, maximum, and effective values, 1440  
 calculation of circuits, 1457  
 capacity, 1440  
 capacity of conductors, 1446  
 converters, 1453  
 delta connection, 1446  
 frequency, 1440  
 generators, for, 1448  
 impedance, 1441  
 impedance polygons, 1442  
 inductance, 1440  
 induction motor, 1463
- Alternating currents**, measurement of power in polyphase circuits, 1447  
 motors, variable speed, 1463  
 Ohm's law applied to, 1442  
 power factor, 1440  
 reactance, 1441  
 single and polyphase, 1445  
 skin effect, 1442  
 standard voltages of, 1460  
 synchronous motors, 1463  
 transformers, 1451  
 Y-connection, 1446
- Altitude by barometer**, 608
- Aluminum**, 177, 380  
 alloys (*see also* Alloys), 396-399  
 alloys, tests of, 398  
 alloys used in automobile construction, 400  
 brass, 397  
 bronze, 396  
 bronze wire, 248  
 coating on iron, 473  
 conductors, cost compared with copper, 1459  
 effect of, on cast iron, 439  
 electrical conductivity of, 1401  
 plates, sheets, and bars, weight of, tables, 230  
 properties and uses, 380  
 sheets and bars, table, 230  
 solder, 382-383  
 steel, 496  
 strength of, 381, 383  
 thermit process, 400  
 tubing, 226  
 wire, 248, 381, 383  
 wire, electrical resistance of, table, 1414
- Ammonia**, aqua, strength of, 1341  
 -absorption refrigerating machine, 1346, 1364  
 -absorption refrigerating machine, test of, 1364  
 carbon dioxide and sulphur dioxide, cooling effect, and compressor volume, 1341  
 -compression machines, tests of, 1359-1364  
 -compression refrigerating machines, 1345, 1356  
 gas, properties of, 1338  
 heat generated by absorption of, 1341  
 liquid, properties of, 1340  
 solubility of, 1341  
 superheated, properties of, 1340
- Ampere**, definition of, 1397
- Analyses**, asbestos, 270  
 boiler scale, 722  
 boiler water, 722  
 cast iron, 439-450  
 coals, 821-830  
 crucible steel, 490, 494  
 fire-clay, 269  
 gas, 854  
 gases of combustion, 817  
 magnesite, 270



- Analyses of rubber goods, 378  
 Analytical geometry, 70-73  
 Anchor bolts for chimneys, 957  
   forgings, strength of, 353  
 Anemometer, 624  
**Angle**, economical, of framed structures, 548  
   of repose of building material, 1220  
 Angles, Carnegie steel, properties of, table, 317-321  
   plotting, without protractor, 53  
   problems in, 38  
   steel, gage lines for, 321  
   steel, tests of, 362  
   steel, used as beams, table of safe loads, 321  
   trigonometrical properties of, 66  
 Angular velocity, 522  
 Animal power, 532-534  
**Annealing**, effect on conductivity, 1402  
   effect of, on steel, 479  
   influence of, on magnetic capacity of steel, 483  
   malleable castings, 455  
   of steel, 484, 492 (*see* Steel)  
   of steel forgings, 482  
   of structural steel, 484  
 Annuities, 15-17  
 Annular gearing, 1169  
 Anthracite, classification of, 819, 828  
   composition of, 819, 820, 828  
   gas, 845  
   sizes of, 823  
   space occupied by, 823  
 Anti-friction curve, 50, 1232  
   metals, 1223  
 Anti-logarithm, 136  
 Antimony, in alloys, 405, 407  
   properties of, 177  
 Apothecaries' measure and weight, 18, 19  
 Arbitration bar, for cast iron, 441  
 Arc, circular, length of, 58  
   circular, relations of, 58  
   lamps (*see* Electric lighting)  
   lights, electric, 1469  
 Arcs, circular, table, 122-124  
 Arches, corrugated, 195  
**Area** of circles, square feet, diameters feet and inches, 131, 132  
   of circles, table, 111-119  
   of geometric (plane) figures, 54-61  
   of irregular figures, 56, 57  
   of sphere, 62  
 Arithmetic, 2-32  
 Arithmetical progression, 10  
 Armature circuit, e.m.f. of, 1436  
   torque of, 1435  
 "Armco ingot iron," 477  
 Armor-plates, heat treatment of, 482  
 Artesian well pumping by compressed air, 810  
 Asbestos, 270  
 Asphaltum coating for iron, 471  
 Asses, work of, 534  
 Asymptotes of hyperbola, 73  
 Atmosphere (*see also* Air)  
   equivalent pressures of, 27  
   moisture in, 609-613  
   pressure of, 607, 608  
 Atomic weights (table), 173  
 Austenite, 480  
 Autogenous welding, 488  
 Automatic cut-off engines, water consumption of, 967  
 Automobile engines, rated capacity of, 1101  
   gears, efficiency of, 1172  
   screws and nuts, table, 232  
 Automobiles, steel used in, 510  
 Avogadro's law of gases, 604  
 Avoirdupois weight, 19  
 Axles, forcing fits of, by hydraulic pressure, 1324  
   railroad, effect of cold on, 465  
   steel, specifications for, 507, 509  
   steel, strength of, 354  
**B**ABBITT metal, 407, 408  
 Bagasse as fuel, 839  
 Balances, to weigh on incorrect, 20  
 Balls and rollers, carrying capacity of, 340  
   for bearings, grades of, 1237  
   hollow copper, resistance to collapse, 345  
 Ball-bearings, 1233, 1235  
   saving of power by, 1237  
 Band brakes, design of, 1240  
 Bands and belts for carrying coal, etc., 1198  
   and belts, theory of, 1138  
 Bank discount, 13  
 Bar iron (*see* Wrought iron)  
 Bars, eye, tests of, 360  
   iron and steel, commercial sizes of, 182  
   Lowmoor iron, strength of, 352  
   of various materials, weights of, 181  
   steel (*see* Steel)  
   twisted, tensile strength of, 280  
   wrought-iron, compression tests of, 359  
 Barometer, leveling with, 607  
   to find altitude by, 608  
 Barometric readings for various altitudes, 608  
 Barrels, to find volume of, 65  
   number of, in tanks, 134  
 Barth key, 1329  
 Basic Bessemer steel, strength of, 476  
 Batteries, primary electric, 1425  
   storage, 1425-1428  
 Baumé's hydrometer, 175  
 Bazin's experiments on weirs, 763

- Beams and girders, safe loads on,**  
 1387  
 formula for flexure of, 299  
 formulæ for transverse strength of, 299  
 of uniform strength, 301  
 special, coefficients for loads on, 300  
 steel, formulæ for safe loads on, 298  
 wooden, safe loads, by building laws, 1387  
 yellow pine, safe loads on, 1387, 1393
- Beardslee's tests on elevation of elastic limit,** 275
- Bearing-metal alloys,** 405  
 practice, 407
- Bearing-metals, anti-friction,** 1223  
 composition of, 390
- Bearing pressure on rivets,** 426  
 pressure with intermittent loads, 1231
- Bearings, allowable pressure on,** 1226, 1230  
 and journals clearance in, 1230  
 ball, 1233, 1235  
 cast-iron, 1223  
 conical roller, 1234  
 engine, calculating dimensions of, 1042-1044  
 engine, temperature of, 1232  
 for high rotative speeds, 1231  
 for steam turbines, 1232  
 knife-edge, 1238  
 mercury pivot, 1233  
 of Corliss engines, 1232  
 of locomotives, 1232  
 oil pivot, in Curtis steam turbine, 1083  
 oil pressure in, 1228  
 overheating of, 1228  
 pivot, 1229, 1232  
 roller, 1233  
 shaft, length of, 1034  
 steam-engine, 1232, 1238  
 thrust, 1232
- Bed-plates of steam-engine,** 1044
- Bell-metal, composition of,** 390
- Belt conveyors, 1198-1201**  
 dressings, 1151  
 factors, 1142
- Belts and pulleys, arrangement of,** 1149  
 care of, 1150  
 cement for leather or cloth, 1152  
 centrifugal tension of, 1139  
 effect of humidity on, 1150  
 endless, 1151  
 evil of tight, 1149  
 lacing of, 1147  
 length of, 1148  
 open and crossed, 1136  
 quarter twist, 1147  
 sag of, 1149  
 steel, 1152
- Belting, 1138-1152**  
 Barth's studies on, 1146
- Belting, formulæ,** 1139  
 friction of, 1138  
 horse-power of, 1139-1142  
 notes on, 1146  
 practice, 1139  
 rubber, 1152  
 strength of, 357, 1150  
 Taylor's rules for, 1143  
 theory of, 1138  
*vs.* chain drives, 1155  
 width for given horse-power, 1140
- Bends, effects of, on flow of water in pipes,** 747, 748  
 in pipes, 624  
 in pipes, table, 221, 222  
 pipe, flexibility of, 221  
 valves, etc., resistance to flow in, 879
- Bending curvature of wire rope,** 1213
- Bent lever,** 514, 536
- Bernoulli's theorem,** 617, 765
- Bessemer converter, temperature in,** 555  
 steel, 475 (*see* Steel, Bessemer)
- Bessemerized cast iron,** 453
- Bethlehem girder beams, properties of, table,** 331  
 I-beams, table, 332  
 steel H-columns, 333
- Bevel wheels,** 1169
- Billets, steel, specifications for,** 507
- Binomial, any power of,** 33  
 theorem, 37
- Bins, coal-storage,** 1196
- Birmingham gage,** 28
- Bismuth alloys,** 404  
 properties of, 178
- Bituminous coal (*see* Coal)**  
 coating for pipe, 206
- Black body radiation,** 579
- Blast area of fans,** 655  
 pipes (*see* Pipes)
- Blast-furnace, consumption of charcoal in,** 837  
 gas, 855  
 steam-boilers for, 899  
 temperatures in, 555
- Blechynden's tests of heat transmission,** 593
- Blocks or pulleys, 538, 539, 1181**  
 or pulleys, strength of, 1181
- Blooms, steel weight of, table,** 190
- Blow, force of,** 529
- Blowers (*see also* Fans), 663-681**  
 and fans, comparative efficiency, 656  
 blast-pipe diameters for, 671  
 in foundries, 1250  
 rotary, 677  
 rotary, for cupolas, 678  
 steam-jet, 679
- Blowing-engines, dimensions of,** 680  
 horse-power of, 680
- Blowing-machines, centrifugal,** 648, 649

- Blowpipe, acetylene, 857  
 Blue heat, effect on steel, 482  
 Board measure, 20  
 Boats (*see* Ships)  
 Boats, motor, power required for, 1101  
 Bodies, falling, laws of, 521  
**Boiler** compounds, 930  
   explosions, 932  
   feed-pumps, 792  
   feeders, gravity, 938  
   furnaces, height of, 889  
   furnaces, use of steam in, 854  
   heads, 914  
   heads, strength of, 337, 338  
   heating-surface for steam heating, 693-697  
   plate, strength of, at high temperatures, 463  
   scale, analyses of, 722  
   tube joints, rolled, slipping point of, 364  
   tubes, dimensions of, table, 204  
   tubes, expanded, holding power of, 364  
 Boilers for house heating, 693  
   for steam-heating, 694-697  
   horse-power of, 885  
   incrustation of, 721, 927-932  
   locomotive, 1113  
   natural gas as fuel for, 847  
   of the "Lusitania," 1381  
   steam, 885-944 (*see* Steam-boilers)  
 Boiling-point of water, 719  
   of substances, 559  
 Boiling, resistance to, 570  
**Bolts** and nuts, 231-238  
   and pins, taper, 1318  
   effect of initial strain in, 347  
   hanger, 243  
   holding power of in white pine, 346  
   square-head, table of weights of, 242  
   strength of, tables, 348  
   stud, 237  
   track, weight of, 244, 245  
 Bonds, rail, electric resistance of, 1416  
 Boosters, 1456  
 Boyle's or Mariotte's law, 600, 603  
 Braces, diagonal, stresses in, 542, 545  
 Brackets, cast-iron, strength of, 292  
 Brake horse-power, 970  
   horse-power, definition of, 1017  
   Prony, 1333  
 Brakes, band, design of, 1240  
   electric, 1240  
   friction, 1239  
   magnetic, 1240  
**Brass** alloys, 390  
   and copper-lined iron pipe, 227  
   and copper tubes, coils and bends, 222  
   influence of lead on, 394  
 Brass plates, bars, and wire, tables, 228, 229  
   rolled, composition of, 391  
   sheets and bars, table, 228, 229  
   tube, seamless, table, 224, 225  
   wire, weight of, table, 229  
 Brazing metal, composition of, 390  
   of aluminum bronze, 397  
   solder, composition of, 390  
**Brick**, absorption of water by, 370  
   fire, number required for various circles, table, 267  
   fire, sizes and shapes of, 266  
   kiln, temperature in, 555  
   magnesia, 269  
   piers, safe strength of, 1386  
   sand-lime, tests of, 371  
   specific gravity of, 177  
   strength of, 358, 370-372  
   weight of, 180, 370  
   zirconia, 270  
 Bricks and blocks, slag, 268  
 Brickwork, allowable pressures on, 1386  
   measure of, 180  
   weight of, 180  
 Bridge iron, durability of, 466  
   links, steel, strength of, 353  
   members, strains allowed in, 287  
   trusses, 543-547  
 Brine, boiling of, 570  
   properties of, 570, 571, 1343  
 Brinell's tests of hardness, 364  
 Briquettes, coal, 831  
 Britannia metal, composition of, 407  
 British thermal unit (B.T.U.), 560, 867  
 Brittleness of steel (*see* Steel)  
**Bronze**, aluminum, strength of, 396  
   ancient, composition of, 388  
   deoxidized, composition of, 395  
   Gurley's, composition of, 390  
   manganese, 401  
   navy-yard, strength of, 398  
   phosphor, 394  
   strength of, 356  
   Tobin, 391, 392  
   variation in strength of, 386  
 Buffing and polishing, 1310  
**Building**-laws, New York City, 1388-1390  
   -laws on columns, New York, Boston, and Chicago, 292  
   -materials, coefficients of friction of, 1220  
   -materials, sizes and weights, 177, 180, 191  
 Buildings, construction of, 1385-1395  
   fire-proof, 1389  
   heating and ventilation of, 684  
   mill, approximate cost of, 1394  
   transmission of heat through walls of, 688  
   walls of, 1388



- Bulkheads, plating and framing  
for, table, 339  
stresses in due to water-pres-  
sure, 338
- Buoyancy, 719
- Burners, acetylene, 857  
fuel oil, 842
- Burning of steel, 481
- Burr truss, stresses in, 544
- Bush-metal, composition of, 390
- Bushel of coal and of coke, weight  
of, 834
- Butt-joints, riveted, 428
- C** G. S. system of measure-  
ments, 1396
- CO<sub>2</sub>, (see also carbon dioxide,  
carbonic acid)
- CO<sub>2</sub> recorders, autographic, 891
- CO<sub>2</sub>, temperature required for  
production of, 852
- Cable, formula for deflection of,  
1207  
traction ropes, 256
- Cables (see Wire rope)  
chain, proving tests of, 264  
chain, wrought-iron, 264, 265  
galvanized steel, 255  
suspension-bridge, 255
- Cable-ways, suspension, 1205
- Cadmium, properties of, 178
- Calcium carbide and acetylene,  
855  
chloride in refrigerating-ma-  
chines, 1343
- Calculus, 73-82
- Caloric engines, 1095
- Caloric, definition of, 560
- Calorimeter for coal, Mahler  
bomb, 826  
steam, 942-944  
steam, coil, 943  
steam, separating, 943  
steam, throttling, 943
- Calorimetric tests of coal, 826, 827
- Cam, 537
- Campbell's formulæ for strength  
of steel, 477
- Canals, irrigation, 755
- Candle-power, definition of, 1469  
of electric lights, 1468-1476  
of gas lights, 860  
per watt of lamps, 1475
- Canvas, strength of, 357
- Cap screws, dimensions of, 238  
table of standard, 238
- Capacity, electrical, 1440  
electrical, of conductors, 1445
- Car heating by steam, 702  
journals, friction of, 1228  
wheel, irons used for, 453
- Cars, steel plate for, 507
- Carbon, burning out of steel, 485  
dioxide (see also CO<sub>2</sub>)  
dioxide exhaled by a man, 687  
dioxide in air, 687  
dioxide, pressure, volume, etc.,  
1341
- Carbon, effect of, on strength of  
steel, 476  
gas, 845
- Carbonic acid, allowable in air,  
681, 685
- Carbonizing (see Case-hardening)
- Carborundum, made in the elec-  
tric furnace, 1425
- Cargo hoisting by rope, 414
- Carnegie steel sections, proper-  
ties of, 305-321
- Carnot cycle, 598, 600  
cycle, efficiency of steam in, 881
- Carriages, resistance of, on roads,  
534
- Carriers, bucket, 1197
- Case-hardening of iron and steel,  
510, 1291
- Casks, volume of, 65
- Cast copper, strength of, 356, 384
- Cast-iron**, 437-454  
addition to, of ferro-silicon,  
titanium, vanadium, and  
manganese, 450  
analyses of, 439-450  
bad, 453  
bars, tests of, 444  
beams, strength of, 451  
Bessemerized, 453  
chemistry of, 438-443  
columns, eccentric loading of,  
296  
columns, strength of, 289-292  
columns, tests of, 290  
columns, weight of, table, 200  
combined carbon changed to  
graphite by heating, 448  
compressive strength of, 283  
corrosion of, 466  
cylinders, bursting strength of,  
452  
durability of, 466  
effect of cupola melting, 450  
expansion in cooling, 448  
growth of by heating, 1254  
hard, due to excessive silicon,  
1254  
influence of length of bar on  
strength, 446  
influence of phosphorus, sul-  
phur, etc., 438  
journal bearings, 1223  
malleable, 454  
manufacture of, 437  
mixture of, with steel, 453  
mobility of molecules of, 449  
permanent expansion of, by  
heating, 453  
pipe, 196-200 (see Pipe, cast-  
iron)  
pipe-fittings, sizes and weights,  
206-216  
relation of chemical composi-  
tion to fracture, 446  
shrinkage of, 438, 447, 1254  
specific gravity and strength,  
452  
specifications for, 441

- Cast-iron strength in relation to silicon and cross-section, 447  
 strength in relation to size of bar and to chemical constitution, 446  
 strength of, 445-447  
 tests of, 352, 444-447  
 theory of relation of strength to composition, 446  
 variation of density and tenacity, 452  
 water pipe, transverse strength of, 452  
 white, converted into gray by heating, 448
- Castings**, deformation of, by shrinkage, 448  
 from blast-furnace metal, 450  
 hard, from soft pig, 450  
 hard to drill, due to low Mn, 450  
 iron, analysis of, 439  
 iron, chemical standards for, 441  
 iron, strength of, 352  
 made in permanent cast-iron molds, 1255  
 shrinkage of, 1254  
 specifications for, 441  
 steel, 489, 510  
 steel, specifications for, 489, 510  
 steel, strength of, 355  
 weakness of large, 1253  
 weight of, from pattern, 1256
- Catenary, to plot, 52
- Cement as a preservative coating, 471  
 for leather belts, 1152  
 Portland, strength of, 358  
 Portland, tests of, 373  
 weight and specific gravity of, 177
- Cements, mortar, strength of, 372
- Cementation or case-hardening, 510, 1291
- Cementite, 439, 480
- Center of gravity, 516  
 of gravity, of regular figures, 516  
 of gyration, 518  
 of oscillation, 518  
 of percussion, 518
- Centigrade-Fahrenheit conversion table, 550, 551
- Centigrade, thermometer scale, 550, 551
- Centrifugal air compressors, 648, 649  
 fans (*see* Fans, centrifugal)  
 fans, high-pressure, 648, 649  
 force, 521  
 force in fly-wheels, 1047  
 pumps (*see* Pumps, centrifugal), 796-802  
 tension of belts, 1139
- Chain-blocks, efficiency of, 1181
- Chain-cables, proving tests of, 264  
 weight and strength of, 264
- Chain-drives, 1153  
 silent, 1156  
*vs.* belting, 1155
- Chain-hoists, 1181
- Chains**, formulæ for safe load on, 348  
 link-belt, 1196  
 monobar, 1199  
 pin, 1199  
 pitch, breaking and working strains of, 265  
 roller, 1199  
 sizes, weights and properties, 264, 265  
 specifications for, 264  
 strength of, tables, 264, 265  
 tests of, 264, 265
- Chalk, strength of, 371
- Change gears for lathes, 1260
- Channels, Carnegie steel, properties of, table, 312-313  
 open, velocity of water in, 755  
 safe loads, table, 313  
 strength of, 352
- Charcoal, 836-837  
 absorption of gases and water by, 837  
 bushel of, 180  
 composition of, 836  
 pig iron, 440, 452  
 results from different methods of making, 837  
 weights per cubic foot, 180
- Charles's law, 600, 604
- Chatter in tools, 1264
- Chemical elements, table, 173  
 symbols, 173
- Chemistry of cast iron, 438-443
- Chezy's formula for flow of water, 728
- Chilling cast iron, 441
- Chimneys**, 944-958  
 anchor bolts for, 957  
 draught intensity in, 945  
 draught, power of, 946  
 draught, theory, 944  
 draught with oil fuel, 952  
 effect of flues on draught, 947  
 for ventilating, 712  
 height of, 948  
 height of water column due to unbalanced pressure in, 946  
 interior, of Equitable building, 954  
 largest in the world, 952, 954  
 lightning protection of, 949  
 radial brick, 954  
 rate of combustion due to height of, 947  
 reinforced concrete, 958  
 sheet iron, 958  
 size of, table, 950  
 size of, for oil fuel, 951  
 stability of, 954  
 steel, 956  
 steel, design of, 956  
 steel, foundation for, 957, 958  
 tall brick, 953

- Chimneys, velocity of air in, 946  
 velocity of gas in, 951  
 with forced draught, 952
- Chisels, cold, cutting angle of, 1261
- Chord of circle, 58
- Chords of trusses, strains in, 545
- Chrome paints, anti-corrosive, 469
- Chromic steel, 496
- Chromium-vanadium steels, 500-502
- Cippoletti weir, 764
- Circle**, 57-60  
 area of, 57  
 circumferences in feet, diameters in inches, table, 1310  
 circumferences of, 1 inch to 32 feet, 120  
 diameter of to enclose a number of rings, 51  
 equation of, 71  
 large, to describe an arc of, 51  
 length of arc of, 58  
 length of arc of, Huyghen's approximation, 58  
 length of chord of, 58  
 problems, 37-44  
 properties of, 57, 58  
 relation of arc, chord, etc., of, 58  
 relations of, to equal, inscribed and circumscribed square, 59  
 sectors and segments of, 60
- Circles, area in square feet, diameter in inches (table of cylinders), 131, 132  
 circumference and area of, table, 111-119  
 diameter of and sides of equivalent square, 125  
 number inscribed in a larger circle, 125
- Circuits**, alternating current (*see* Alternating Current)  
 electric (*see* Electric circuits)  
 electric, e.m.f. in, 1406  
 electric, polyphase, 1445 (*see* Alternating currents)  
 electric, power of, 1408  
 magnetic, 1430
- Circular arcs**, lengths of, 58  
 arcs, lengths of, tables, 122-124  
 curve, formulæ for, 59  
 functions, Calculus, 81  
 inch, 18  
 measure, 20  
 mil, 18, 29, 30  
 mil wire gage, 29, 30  
 pitch of gears, 1158  
 ring, 60  
 segments, areas of, 121, 122
- Circumference of circles, 1 inch to 32 feet, table, 120  
 of circles, table, 111-119
- Cisterns and tanks, number of barrels in, 134  
 capacity of, 132-134
- Classification of iron and steel, 436
- Clay, cubic feet per ton, 181  
 fire, analysis, 269  
 melting point of, 556
- Clearance between journal and bearing, 1230  
 in steam-engines, 966, 1021  
 of rivet heads, 322
- Clutches, friction, 1179, 1239
- Coal**, analysis of, 821-830  
 analyses and heating values of various, tables, 828-830  
 and coke, Connellsville, 824  
 anthracite, sizes of, 823  
 approximate heating value of, 822  
 bituminous, classification of, 819  
 briquets, 831  
 burning, Illinois without smoke, 921  
 caking and non-caking, 820  
 calorimeter, 826  
 calorimetric tests of, 826, 827  
 cannel, 821  
 classification of, 819-821  
 conveyors, 1197  
 cost of for steam power, 1010  
 cubic feet per ton, 180  
 Dulong's formula for heating value of, 827  
 efficiencies of, in gas-engine tests, 853  
 foreign, analysis of, 825  
 -gas, composition of, 860  
 -gas, manufacture, 858  
 heating value of, 821-824, 828-830  
 products of distillation of, 834  
 purchase of, by specification, 830  
 Rhode Island graphitic, 821  
 sampling, for analysis, 825, 900  
 semi-anthracite, 824  
 semi-bituminous, composition of, 819-823, 828  
 space occupied by anthracite, 823  
 spontaneous combustion of, 832  
 steam, relative value of, 826  
 storage bins, 1196  
 tests of, 822, 823  
 vs. oil as fuel, 842, 843  
 washing, 833  
 weathering of, 830  
 weight of bushel of, 834  
 Welsh, analysis of, 825
- Coals, furnaces for different, 827
- Coatings, preservative, 471-474
- Coatings, protective, for pipe, 206
- Coefficient of elasticity**, 274, 374  
 expansion, 566 (*see* Expansion by heat)  
 fineness, 1369  
 friction, definition, 1219  
 friction of journals, 1220  
 friction, rolling, 1220  
 friction, tables, 1220-1223  
 performance of ships, 1370  
 propellers, 1378



- Coefficient of transverse strength, 297  
 water lines, 1369
- Coils and bends of brass tubes, 222  
 electric, heating of, 1409  
 heat radiated from, in blower system, 708
- Coiled pipes, 221
- Coke, analyses of, 833  
 by-products of manufacture of, 833, 834  
 foundry, quality of, 1255  
 ovens, generation of steam from waste heat of, 834  
 weight of, 180, 834
- Coking, experiments in, 833
- Cold**-chisels, form of, 1261  
 -drawing, effect of, on steel, 361  
 -drawn steel, tests of, 361  
 effect of, on railroad axles, 465  
 effect of, on strength of iron and steel, 464  
 -rolled steel, tests of, 361  
 -rolling, effect of, on steel, 479  
 -saw, 1309
- Collapse of corrugated furnaces, 342  
 of tubes, tests of, 341-344  
 resistance of hollow cylinders to, 341-345
- Collars for shafting, 1133
- Cologarithm, 137
- Color determination of temperature, 558
- Color scale for steel tempering, 493
- Color values of various illuminants, 1469
- Columns**, built steel, tests of, 287  
 Carnegie channel, dimensions and safe loads, 323-327  
 Carnegie plate and angle, 323, 328-330  
 cast-iron, strength of, 289-292  
 cast-iron, tests of, 290  
 cast-iron, weight of, table, 200  
 comparison of formulæ for, 286  
 eccentric, loading of, 296  
 Gordon's formula for, 284  
 Hodgkinson's formula for, 283  
 made of old boiler tubes, tests of, 363  
 mill, 1393  
 permissible stresses in, 286  
 strength of, by New York building laws, 1389  
 wrought-iron, tests of, 360  
 wrought-iron, ultimate strength of, table, 285
- Combination, 10
- Combined stresses, 335
- Combustion**, analyses of gases of, 817  
 heat of, 560  
 of fuels, 816  
 of gases, rise of temperature in, 818
- Combustion, rate of, due to chimneys, 947  
 spontaneous, of coal, 832  
 theory of, 816
- Commutating-pole motors, 1437
- Composition of forces, 513
- Compound engines (*see* Steam-engines, compound), 976-983  
 interest, 13, 14  
 locomotives, 1122, 1124  
 proportion, 7  
 numbers, 5  
 units of weights and measures, 27
- Compressed-air**, 623, 632-653  
 adiabatic and isothermal compression, 633  
 cranes, 1192  
 diagrams, curve of, 636  
 drills driven by, 645  
 engines, adiabatic expansion in, 638  
 engines, efficiency, 641  
 flow of, in pipes, 618-624  
 for motors, effect of heating, 639-641  
 formulæ, 633  
 for street railways, 652  
 gain due to reheating, 647  
 hoisting engines, 646  
 horse-power required to compress air, 637  
 locomotives, 1128  
 loss of energy in, 632  
 losses due to heating, 633  
 machines, air required to run, 645, 647  
 mean effective pressures, tables, 636, 637  
 mine pumps, 652  
 moisture in, 611  
 motors, 639-641  
 motors with return-air circuit, 648  
 Popp system, 639-641  
 practical applications of, 647  
 pumping with (*see also* Air-lift), 645  
 reheating of, 641  
 table for pumping plants, 645  
 tramways, 652  
 transmission, efficiencies of, 641  
 two-stage compression, 635  
 volumes, pressures, temperatures, table, 636  
 work of adiabatic compression, 634
- Compressed steel, 488
- Compressibility of liquids, 175  
 of water, 721
- Compression**, adiabatic, formulæ for, 633  
 and flexure combined, 335  
 and shear combined, 335  
 and torsion combined, 335  
 in steam-engines, 965  
 of air, tables, 635-638
- Compressive strength, 281-283

- Compressive strength of iron bars, 359  
 strength of woods, 366  
 tests, specimens for, 282
- Compressor volume in refrigerating, 1341
- Compressors, air, effect of intake temperature, 647  
 air, tables of, 641-643
- Concrete, crushing strength of 12-in. cubes, 1386  
 durability of iron in, 466  
 reinforced, allowable working stresses, 1386
- Condenser**, barometric, 1069  
 the Leblanc, 1056  
 tubes, heat transmission in, 589
- Condensers, 1069-1079  
 air-pump for, 1071, 1073  
 calculation of surface of, 939  
 choice of, 1078  
 circulating pump for, 1075  
 continuous use of cooling water in, 1076  
 contraflow, 1071  
 cooling-towers for, 1079  
 cooling water required, 1068  
 ejector, 1069  
 evaporative surface, 1076  
 for refrigerating machines, 1353  
 heat transference in, 1070  
 increase of power due to, 1077  
 jet, 1068  
 surface, 1069  
 tubes and tube plates of, 1072, 1073
- Condensing apparatus, power used by, 1071
- Conductance, electrical, 1401
- Conduction of heat, 580  
 of heat, external and internal, 580
- Conductivity, electrical, of metal, 1401  
 electric, of steel, 477
- Conductors, electrical, heating of, 1408  
 electrical, in series or parallel, resistance of, 1407
- Conduit, water, efficiency of, 766
- Cone, measures of, 62  
 pulleys, 1136
- Conic sections, 73
- Connecting - rods, steam - engine, 1025  
 tapered, 1026
- Connections, transformer, 1452
- Conoid, parabolic, 65
- Conoidal fans, 666
- Conservation of energy, 531
- Constantan, copper-nickel alloy, 403
- Constants, steam-engine, 971-974
- Construction of buildings, 1385-1395
- Controllers, for electric motors, 1462
- Convection, Dulong's law of, table of factors, for, 597  
 loss of heat due to, 596  
 of heat, 580
- Conversion tables, metric, 23-26
- Converter, Bessemer, temperature in, 555
- Converters, electric, 1453  
 synchronous, 1453
- Conveying of coal in mines, 1203
- Conveyors, belt, 1198-1201  
 cable-hoist, 1205  
 coal, 1197  
 horse-power required for, 1198, 1200  
 screw, 1198
- Cooling agents in refrigeration, 1342  
 air for ventilation, 710  
 effect, in refrigerating, 1341  
 of air, 594  
 of air by washing, 687
- Cooling-tower**, air per pound of circulating water, table, 1081  
 air supply required for, 1080  
 for condensers, 1079  
 practice in refrigerating plants, 1354  
 water evaporated per pound of air, 1080  
 water vapor mixed with air, table, 1081
- Co-ordinate axes, 70
- Copper**, 178  
 and brass-lined iron pipe, 227  
 ball pyrometer, 553  
 balls, hollow, 345  
 cast, strength of, 356, 384  
 castings of high conductivity, 368  
 density of, 1406  
 drawn, strength of, 356  
 effect of on cast-iron, 438  
 electric conductivity of, 1402  
 -manganese alloys, 401  
 -nickel alloys, 402  
 plates, strength of, 356  
 resistivity of, 1403  
 temperature coefficient of, 1403  
 tubing, bends and coils, 222  
 rods, weight of, table, 230  
 steels, 499  
 strength of at high temperatures, 368  
 -tin alloys, 384  
 -tin alloys, properties and composition of, 384  
 -tin-zinc alloys, law of variation of strength of, 388  
 -tin-zinc alloys, properties and composition, 387  
 -vanadium alloys, 395  
 weight required in different systems of transmission, 1459
- Copper-wire** and plates, weight of, table, 229  
 carrying capacity of, Underwriter's table, 1410

- Copper-wire, cross-section required for a given current, 1410  
 electrical resistance, table, 1404  
 stranded, 253  
 table of electrical resistance, 1404  
 weight of for electric circuits, 1410
- Copper-zinc alloys, strength of, 386  
 -zinc alloys, table of composition and properties, 386  
 -zinc-iron alloys, 393
- Cord of wood, weight of, 181  
 yield of charcoal from, 836
- Cordage, technical terms relating to, 411  
 weight of, 411, 415,
- Cork, properties of, 377
- Corrosion** by stray electric currents, 470  
 due to overstrain, 470  
 electrolytic theory of, 468  
 of iron, 467  
 of pipe in hot-water heating, 708  
 of steam-boilers, 467, 927-932  
 prevention of, 468  
 resistance of aluminum alloys to, 401  
 resistance to of nickel steel, 498
- Corrosive agents in atmosphere, 466
- Corrugated arches, 195  
 furnaces, 342, 917  
 plates, properties of Carnegie steel, table, 310  
 sheets, sizes and weights, 194
- Cosecant of an angle, table, 170-172
- Cosine of an angle, 66  
 of an angle, table, 170-172
- Cost of coal for steam-power, 1010  
 of steam-power, 1009-1011
- Cotangent of an angle, 66
- Cotangents of angles, table, 170-172
- Cotton ropes, strength of, 357
- Coulomb, definition of, 1397
- Counterbalancing of hoisting-engines, 1188  
 of locomotives, 1126  
 of steam-engines, 1008
- Counterpoise system of hoisting, 1189
- Couples, 515
- Couplings, flange, 1133  
 hose, standard sizes, 218
- Coverings for steam-pipe, tests of, 584-587
- Covered sine of angles, table, 170-172
- Cox's formula for loss of head, 734
- Crane chains, 264, 265  
 installations, notable, 1192  
 pillar, 150-ton, 1192
- Cranes**, 1189-1193
- Cranes and hoists, power required for, 1193  
 classification of, 1189  
 compressed air, 1192  
 electric, 1190-1192  
 electric, loads and speeds of, 1191  
 guyed, stresses in, 542  
 jib, 1190  
 power required for, 1191  
 quay, 1193  
 simple, stresses in, 541  
 traveling, 1190-1193
- Crank angles, steam-engine, table, 1058  
 arm, dimensions of, 1029  
 pins, steam-engine, 1027-1029  
 pins, steel, specifications for, 507  
 shaft, steam-engine, torsion and flexure of, 1038  
 shafts, steam-engines, 1030-1038
- Cranks, steam-engines, 1029
- Critical point in heat treatment of steel, 480  
 temperature and pressure of gases and liquids, 606
- Cross-head guides, 1025  
 pin, 1029
- Cross-sections of materials, for draftsmen, 271
- Crucible steel, 475, 490-494 (*see* Steel, crucible)
- Crushing strength of masonry materials, 371
- Crystallization of iron by fatigue, 466
- Cubature of volumes, 77
- Cube root, 9  
 roots, table of, 93-108
- Cubes of decimals, table, 108  
 of numbers, table, 93-108
- Cubic feet and gallons, table, 130  
 measure, 18
- Cupola** fan, power required for, 1253  
 gases, utilization of, 1253  
 loss in melting iron in, 1253  
 practice, 1247-1257  
 practice, improvement of, 1249  
 results of increased driving, 1252
- Cupolas, blast-pipes for, 671  
 blast-pressure in, 1247-1251  
 blowers for, 661, 662  
 charges for, 1247-1250  
 charges in stove foundries, 1250  
 dimensions of, 1247  
 rotary blowers for, 678  
 slag in, 1248
- Current motors, 765
- Currents, electric (*see* Electric currents)
- Curve, railway degree of, 54
- Curve of  $PV^n$ , construction of, 602
- Curves in pipe-lines, resistance of, 747



- Cut-off for various laps and travel of slide valves, 1060
- Cutting metal by oxy-acetylene flame, 488
- metal, resistance overcome in, 1292
- speeds of machine tools, (*see also* Tools, cutting), 1258
- speeds of tools, economical, 1268
- stone with wire, 1309
- Cycloid, construction of, 50
- differential equations of, 81
- integration of, 81
- measures of, 61
- Cycloidal gear-teeth, 1162
- Cylinder** condensation in steam-engines, 966-968
- lubrication, 1245
- measures of, 62
- Cylinders**, hollow, resistance of to collapse, 341-345
- hollow, under tension, 339
- hooped, 340
- hydraulic press, thickness of, 340, 813
- locomotive, 1112
- open-end cast-iron, weight of, 200
- steam-engine (*see* Steam-engines)
- tables of capacities of, 131
- thick hollow, under tension, 339
- thin hollow, under tension, 340
- Cylindrical ring, 64
- tanks, capacities of, table, 132
- D**ALTON'S law of gaseous pressures, 604
- Dam, stability of, 515
- Darcy's formula, flow of water, 732
- formula, table, of flow of water in pipes, 740, 741
- Decimal equivalents of feet and inches, 5
- equivalents of fractions, 3
- gage, 32,
- Decimals, 3
- square and cubes of, 108
- Delta connection for alternating currents, 1447
- Delta connection transformers, 1452
- metal wire, 248, 393
- Denominate numbers, 5
- Deoxidized bronze, 395
- Derrick, stresses in, 542
- Detrick and Harvey key, 1330
- Diagonals, formula for strains in, 545
- Diametral pitch, 1158
- Diesel oil engine, 1102
- Differential** calculus, 73-82
- coefficient, 75
- coefficient, sign of, 78
- gearing, 1169
- of exponential function, 79, 80
- partial, 75
- pulley, 539
- Differential screw, 540, 541
- second, third, etc., 77
- windlass, 540
- Differentials of algebraic functions, 74
- Differentiation, formulæ for, 74
- Discount, 12
- Disk fans (*see* Fans, disk)
- Displacement of ships, 1369, 1374
- Distillation of coal, 834
- Distiller for marine engines, 1082
- Distilling apparatus, multiple system, 570
- Domed heads of boilers, 339
- Domes on steam boilers, 918
- Draught, chimney, intensity of, 945
- chimney, with oil fuel, 952
- forced, chimneys with, 952
- forced for steam boilers, 923
- power of chimneys, 945, 946
- theory of chimneys, 944
- Drawing-press, blanks for, 1322
- Dressings, belt, 1151
- Driers and drying, 574
- performance of, 575
- Drift bolts, resistance of in timber, 346
- Drill gage, table, 30
- Drills**, feeds and speeds for, 1288
- for pipe taps, 201
- high-speed steel, 1285
- performance of, 1289
- rock, air required for, 645
- speed of, 1285
- tap, sizes of, 236, 1320
- twist, experiments with, 1289
- Drilling compounds, 1286
- high-speed, data on, 1289
- holes, speed of, 1287
- steel and cast iron, power required for, 1286, 1287
- Drop in electric circuits, 1407
- press, pressures obtainable by, 1322
- Drums, steam-boiler, 913
- Dry measure, 19
- Drying and evaporation, 569-577
- apparatus, design of, 576
- in a vacuum, 573
- of different materials, 574
- Ductility of metals, table, 180
- Dulong's formula for heating value of coal, 827
- law of convection, table of factors for, 597
- law of radiation, table of factors for, 596
- Durability of cutting tools, 1268
- of iron, 465-467
- Durand's rule for areas, 56
- Dust explosions, 837
- fuel, 837
- Duty, measure of, 27
- of pumping-engines, 802
- trials of pumping-engines, 802-806
- Dynamics, fundamental equations of, 525

**Dynamo-electric machines**, classification of, 1437  
 e.m.f. of armature circuit, 1436  
 moving force of, 1435  
 torque of armature, 1435  
 strength of field, 1436  
**Dynamometers**, 1333  
 Alden absorption, 1334  
 hydraulic absorption, 6000 H.P., 1335  
 Prony brake, 1333  
 traction, 1333  
 transmission, 1335  
**Dynamotors**, 1457  
**Dyne**, definition of, 512

**EARTH**, cubic feet per ton, 181  
 Eccentric loading of columns, 296

Eccentric, steam-engine, 1039  
 Economical angle of framed structures, 548

Economics of power-plants, 1011  
 Economizers, fuel (*see* Fuel economizers), 924

Edison wire gage, 29, 30

**Efficiency**, definition of, 12  
 of a machine, 532  
 of compressed-air engines, 641  
 of compressed-air transmission, 641  
 of differential screw, 541  
 of electric systems, 1412  
 of fans, 656, 657  
 of injector, 937  
 of pumps, 790  
 of riveted joints, 428-434  
 of screw, 538  
 of screw bolts, 538  
 of steam-boilers, 891  
 of steam-engines, 964

Ejector condensers, 1069

**Elastic Limit**, 273-278  
 apparent, 273  
 Bauschinger's definition of, 275  
 elevation of, 275  
 relation of, to endurance, 275  
 Wohler's experiments on, 275

Elastic resilience, 274  
 resistance to torsion, 334  
 Elasticity, coefficient of, 274  
 moduli of, of various materials, 374  
 modulus of, 274

**Electric brakes**, 1240  
 circuits (*see* Circuits, electric)  
 conductivity of steel, 477  
 current, alternating, 1440-1461  
 (*see* Alternating currents)  
 current, cost of fuel for, 796  
 current determining the direction of, 1432  
 current required to fuse wires, 1409  
 currents, direct, 1406  
 currents, heating due to, 1408  
 currents, short-circuiting of, 1411

Electric furnaces, 1422  
 heaters, 713, 1420  
 heating, 713  
 lighting, 1468-1477  
 lighting, cost of, 1475  
 lighting, terms used in, 1468  
 locomotive, 1416

**Electric Motors** (*see also* Motors), 1461  
 alternating current, variable speed, 1463  
 changing the number of poles, 1463  
 for the machine-shop, 1294-1303, 1466  
 for machine tools, 1294-1303, 1467  
 for wood-working tools, 1303-1305  
 selection of, for different service, 1464  
 speed control of, 1462  
 types used for various purposes, 1464

Electric power, cost of, 1012  
 process of treating iron surfaces, 473

**Electric Railways**, 1414  
 adhesion between wheel and rail, 1416  
 cars, resistance of, 1110  
 efficiency of distributing systems, 1417  
 safe speed on curves, 1416  
 steam railroads electrified, 1418  
 Electric resistance of steel rails, 1416  
 smelting of pig iron, 1424  
 stations, economy of engines in, 992  
 storage batteries, 1425-1428  
 transmission, direct current, 1410-1413  
 transmission, high tension, notes on, 1459  
 transmission, lines, spacing for high voltages, 1460  
 transmission, sag of wires, 1461  
*vs.* steam heating, 1421  
 welding, 1419  
 wires (*see* Wires and Copper wires)

Electrical and mechanical units, equivalent values of, 1399

**Electrical engineering**, 1396-1477  
 horse-power, 970, 1408  
 machinery, shaft fits, allowances for, 1326  
 resistance, 1400  
 resistance of different metals and alloys, 1401  
 resistance of rail bonds, 1416  
 symbols, 1477  
 units, relations of, 1397, 1399

Electricity, analogies to flow of water, 1400  
 standards of measurements, 1396  
 units used in, 1396

Electro-chemical equivalents, 1429

- Electro-magnetic measurements, 1398  
 -magnets, 1430-1437  
 -magnets, polarity of, 1432  
 -magnets, strength of, 1431  
 -motive force of armature circuit, 1436
- Electrolysis, 1428
- Electrolytic theory of corrosion, 468
- Elements, chemical, table, 173  
 of machines, 535-541
- Elevators, coal, 1196  
 gravity discharge, 1197  
 perfect discharge, 1197
- Ellipse, construction of, 45-48  
 equations of, 71  
 measures of, 60
- Ellipsoid, 64
- Elongation, measurement of, 279
- Emery, grades of, 1311  
 wheels, safe speeds, 1316, 1317  
 wheels, speed and selection of, 1310-1315  
 wheels, stress in, 1310  
 wheels, truing and dressing, 1317
- E.M.F. of electric circuits, 1407
- Endless screw, 540
- Endurance of materials, relation of, to elastic limit, 275
- Energy**, available, of expanding steam, 870  
 conservation of, 531  
 definition of, 528  
 intrinsic or internal, 600  
 measure of, 528  
 mechanical, of steam expanded to various pressures, 963  
 of recoil of guns, 531  
 of water flowing in a tube, 746, 765  
 sources of, 531
- Engines**, alcohol, 1102  
 alcohol consumption in, 844  
 automobile, capacity of, 1101  
 blowing, 680  
 compressed air, efficiency of, 639-641  
 fire, capacities of, 752  
 gas, 1095-1108 (*see* Gas-engines)  
 hoisting (*see* Hoisting engines), 1186  
 hot-air or caloric, 1095  
 hydraulic, 815  
 internal combustion, 1095-1108  
 marine, steam-pipes for, 880  
 oil and gasoline, 1101  
 petroleum, 1102  
 pumping, 802-806 (*see* Pumping-engines)  
 steam, 959-1095 (*see* Steam-engines)  
 solar, 1015  
 winding (*see* Hoisting engines), 1186
- Entropy, definition of, 599  
 of water and steam, 602
- Entropy of water and steam, tables, 869, 871-873  
 -temperature diagram, 599
- Epicycloid, 50
- Equalization of pipes, 625, 884
- Equation of payments, 14
- Equation of pipes, 884
- Equations, algebraic, 34-36  
 of circle, 71  
 of ellipse, 71  
 of hyperbola, 72  
 of parabola, 72  
 quadratic, 35  
 referred to co-ordinate axes, 70
- Equilibrium of forces, 516
- Equivalent orifice, mine ventilation, 715
- Equivalents, electro-chemical, 1429
- Erosion of soils by water, 755
- Ether, petroleum, as fuel, 841
- Euler's formula for long columns, 284
- Evaporation**, 569-577  
 by exhaust steam, 572  
 by multiple system, 570  
 factors of, 908-912  
 in a vacuum, 573  
 in salt manufacture, 570  
 latent heat of, 569  
 of sugar solutions, 572  
 of water from reservoirs and channels, 569  
 total heat of, 569  
 unit of, 886
- Evaporator, for marine engines, 1082
- Evolution, 8
- Exciters, 1449
- Exhauster, steam-jet, 679
- Exhaust-steam, evaporation by, 572  
 for heating, 1009
- Expansion**, adiabatic, formulæ for, 638  
 by heat, 565  
 coefficients of, 566
- Expansion of air**, adiabatic, 638  
 cast iron, permanent by heating, 453  
 gases, construction of curve of, 602  
 gases, curve of, 73  
 iron and steel by heat, 465  
 liquids, 567  
 nickel steel, 499  
 solids by heat, 566  
 steam, 959  
 steam, actual ratios of, 965  
 timber, 367  
 water, 716
- Explosions, dust, 837  
 of fuel economizers, 927
- Explosive energy of steam-boilers, 932
- Exponential function, differential of, 79, 80
- Exponents, theory of, 36
- Eye-bars, tests of, 360



- F**ACTOR of evaporation, 908-912  
of safety, 374-377  
of safety, formulæ for, 376  
of safety in steam-boilers, 918
- Factory heating by fan system, 708, 710
- Fahrenheit-Centigrade conversion table, 550, 551
- Failures of stand-pipes, 350  
of steel, 486
- Fairbairn's experiments on riveted joints, 424
- Falling bodies**, graphic representation, 522  
height and velocity of tables, 523, 524  
laws of, 521
- Fan** blowers, types of, 654  
tables, caution in regard to, 662
- Fans** (*see also* Blowers)  
and blowers, 653-681  
and chimneys for ventilation, 712  
and rotary blowers, comparative efficiencies, 657  
best proportions of, 653  
blast-area of, 655  
centrifugal, 648, 649, 653  
centrifugal, high-pressure, 648  
conoidal, 666  
cupola, power required for, 1253  
design of, 653  
disk, 675-677  
disk, influence of speed on efficiency, 675, 677  
effect of resistance on capacity of, 664  
efficiency of, 656, 657, 668  
electric motors for, 1464  
experiments on, 657  
for cupolas, 661  
high-pressure, capacity of, 663  
horse-power of, 668  
influence of spiral casings, 674  
methods of testing, 667  
multiblade, 655, 658  
multiblade, characteristics of, 656  
pipe lines for, 670  
pressure characteristics of, 655  
pressure due to velocity of, 653  
quantity of air delivered by, 655  
relation of speed volume, pressure and power, 656
- Farad, definition and value of, 1397
- Fatigue, crystallization of iron by, 465  
effect of, on iron, 465
- Feed and depth of cut, effect of, on speed of tools, 1264  
-pump (*see* Pumps)
- Feeds and speeds of drills, 1288
- Feed-water**, cold, strains caused by, 939  
heaters, 938-940
- Feed-water heaters, capacity of, 939  
heaters: closed *vs.* open, 940  
heaters, proportions of, 940  
heaters, transmission of heat in, 590  
heating, Nordberg system, 1003  
heating, saving due to, 938  
purification of, 723-726  
to boilers by gravity, 938
- Feet and inches, decimal equivalents of, table, 5
- Fellows stub tooth gear, 1167
- Fence wires, corrosion of, 468
- Ferrite, 439, 480
- Ferro-alloys for foundry use, 1255  
manufacture of, 1424  
silicon, addition of, to cast-iron, 450  
silicon, dangerous, 1255
- Field, magnetic, 1398
- Fifth roots and fifth powers of numbers, 109  
powers, square roots of, 110
- Fineness, coefficient of, 1369
- Finishing temperature, effect of in steel rolling, 478
- Fink roof truss, 547
- Fire, temperature of, 817, 818
- Fire-brick** arches in locomotives, 1115  
number required for various circles, table, 267  
refractoriness of, 268  
sizes and shapes of, 266  
weight of, 266
- Fire-clay, analysis of, 269  
pyrometer, 553, 556
- Fire-engines, capacities of, 752
- Fire-proof buildings, 1389
- Fire-streams, 749-752  
discharge from nozzles at different pressures, 750, 753  
effect of increased hose length, 750  
friction loss in hose, 752  
hydrant pressure required for, table, 750
- Fireless locomotive, 1127
- Fits**, force and shrink, 1324-1327  
force and shrink, pressure required to start, 1327  
limits of diameter for, 1325  
press, pressure required for, 1324-1326  
running, 1325  
stresses due to, 1326
- Fittings (*see* Pipe-fittings), 206-216
- Flagging, strength of, 373
- Flanges**, brass, 214, 215  
cast-iron, forms of, 210, 214-216  
forged and rolled steel, 211  
forged steel, for riveted pipe, 211  
for riveted pipe, 211  
pipe, extra heavy, tables, 210, 212

- Flanges, pipe, tables, 209-213  
 reducing, dimensions of, 214
- Flanged fittings, cast-iron, 208-210
- Flat plates in steam-boilers, 916  
 plates, strength of, 336  
 steel ropes, 258, 261  
 surfaces in steam-boilers, 916
- Flattened strand rope, 258, 261
- Flexure and compression combined, 335  
 and tension combined, 335  
 and torsion combined, 335  
 of beams, formula for, 297, 299
- Flight conveyors, 1197
- Flights, sizes and weights of, 1199
- Floors, maximum load on, 1390-1393  
 strength of, 1390-1393
- Flow of air in long pipes, 618-624**  
 air in pipes, 617-624  
 air through orifices, 615-617, 670  
 compressed air, 618-624  
 gas in pipes, 864-866  
 gas in pipes, tables, 865, 866  
 gases, 605  
 metals, 1323
- Flow of steam at low pressure, 699**  
 capacities of pipes, 877-878  
 in long pipes, 877  
 in pipes, 877-879  
 into atmosphere, 876  
 loss of pressure due to friction, 877  
 loss of pressure due to radiation, 880  
 Napier's rule, 876  
 resistance of bends, valves, etc., 879  
 tables of, 699, 877-879  
 through a nozzle, 876, 1085  
 through safety valves, 934
- Flow of water, 726-746**  
 approximate formulæ, 734, 737, 746  
 Chezy's formula, 728  
 D'Arcy's formula, 732  
 experiments and tables, 737-753  
 exponential formula, 736  
 fall per mile and slope, table, 729  
 formulæ for, 726-746  
 in cast-iron pipe, 737  
 in house service pipes, table, 744  
 in pipes at uniform velocity, table, 739  
 in pipes, table from D'Arcy's formula, 740, 741  
 table from Hazen & Williams' formula, 742, 743  
 table from Kutter's formula, 738, 739  
 in riveted steel pipes, 734-736  
 in 20-in. pipe, 737  
 Kutter's formula, 730
- Flow of water over weirs, 726, 762  
 through nozzles, table, 753  
 through orifices, 726  
 through rectangular orifices, 760  
 values of *c*, 732, 736  
 values of coefficient of friction, 734
- Flowing water, horse-power of, 765  
 water, measurement of, 757-764
- Flues, collapsing pressure of, 341  
 corrugated, 341, 917 (*see also* Tubes and Boilers)
- Flux, magnetic, 1398
- Fly-wheels, arms of, 1050**  
 centrifugal force in, 1047  
 diameters for various speeds, 1048  
 for presses, punches, shears, etc., 1323  
 for steam-engines, 1040, 1044-1052  
 speed, variation in, 1044-1049  
 strains in, 1049  
 thickness of rim of, 1052  
 weight of, 1045-1048  
 weight of, for alternating current units, 1047  
 wire wound, for extreme speeds, 1052  
 wooden rim, 1051
- Foaming or priming of steam-boilers, 721, 930
- Foot-pound, unit of work, 528
- Force, centrifugal, 521**  
 definitions of, 512  
 graphic representation of, 513  
 moment of, 514  
 of a blow, 529, 1322  
 of acceleration, 526  
 units of, 512  
 work, power, etc., 528
- Forces, composition of, 513  
 equilibrium of, 516  
 parallel, 515  
 parallelogram of, 513  
 parallelepipedon of, 514  
 polygon of, 513  
 resolution of, 513
- Forced draught, chimneys with, 952  
 draught in steam-boilers, 923
- Forcing and shrinking fits, 1323-1327 (*see* Fits)
- Forging and grinding of tools, 1263  
 heating of steel for, 492  
 hydraulic, 814, 815  
 of tool steel, 488, 492, 1263
- Forgings, steel, annealing of, 482  
 strength of, 353
- Forging-press, hydraulic, 814
- Föttinger transformer or hydraulic pinion, 1095
- Foundation walls, thickness of, 1386
- Foundations, masonry, allowable pressures on, 1386

- Foundations of buildings, 1386  
**Foundry** coke, quality of, 1255  
   irons (*see* Pig iron and Cast iron)  
   ladles, dimensions of, 1257  
   molding-sand, 1256  
   practice, 1247-1257  
   practice, shrinkage of castings, 1254  
   practice, use of softeners, 1253  
   use of ferro alloys in, 1255  
 Fractions, 2  
   product of, in decimals, 4  
 Framed structures, stresses in, 541-548  
 Frames, steam-engine, 1043  
 Framing, for tanks with flat sides, 339  
 Francis's formulæ for weirs, 762  
 Freezing point of brine, 1343  
   point of water, 719  
 French measures and weights, 21-26  
   thermal unit, 560  
 Frequency changers, 1457  
   of alternating currents, 1440  
   standard, in electric currents, 1440  
 Friction and lubrication, 1219-1246  
   brakes and friction clutches, 1239  
   brakes, capacity of, 1334  
   clutches, 1179  
   coefficient of, definition, 1219  
   coefficient of, in water-pipes, 734  
   coefficients of, tables, 1219-1221  
   drives, power transmitted by, 1178  
   fluid, laws of, 1220  
   laws of, of lubricated journals, 1225  
   loss of head by, in water-pipes, 728, 735, 745  
   moment of, 1229  
   Morin's laws of, 1223  
   of air in mine passages, 714  
   of car journals, 1228  
   of hydraulic packing, 813, 1241  
   of lubricated journals, 1220-1232  
   of metals, under steam pressure, 1223  
   of motion, 1219-1222  
   of pivot bearings, 1229, 1232  
   of rest, 1219  
   of solids, 1219  
   of steam-engines, 1238  
   of steel tires on rails, 1219  
   rollers, 1233  
   rolling, 1219  
   unlubricated, law of, 1219  
   work of, 1229  
 Frictional gearing, 1178  
   resistance of surfaces moved in water, 756  
 Frustum of cone, 62  
 Frustum of parabolic conoid, 65  
   of pyramid, 62  
   of spheroid, 64  
   of spindle, 65  
**Fuel**, 816-858  
   bagasse, 839  
   charcoal, 836-837 (*see* Charcoal)  
   coke, 824, 832-834 (*see* Coke)  
   combustion of, 816  
   dust, 837  
**Fuel, economizers**, 924-927  
   equation of, 925  
   explosions of, 927  
   heating surface of, 925  
   heat transmission in, 925  
   saving due to, 925  
   tests of, 926  
**Fuel for cupolas**, 1248, 1255  
   gas, 845 (*see* Gas)  
   gas, for small furnaces, 854  
   heat of combustion of, 560, 817  
   liquid, 840-844  
   peat, 838  
   pressed, 831  
   sawdust, 838  
   solid, classification of, 818  
   straw, 839  
   theory of combustion of, 816  
   turf, 838  
   value of illuminating gas, 863  
   weight of, 180  
   wet tan bark, 838  
   wood, 835, 836  
**Fuel-oil**, burners for, 842  
   California, heating values of, 842  
   chimney draught with, 952  
   chimney table for, 951  
   specifications for purchase of, 843  
 Functions, trigonometric, tables  
   of, 170-172  
   trigonometric, of half an angle, 69  
   of sum and difference of angles, 68  
   of twice an angle, 69  
**Furnace** for melting iron for malleable castings, 454  
   flues, steam-boiler, formulæ for, 917  
   heating (*see* Heating)  
 Furnaces, blast, gases of, 855  
   blast, temperature in, 555  
   corrugated, 342, 917  
   down draught, 919  
   electric, 1422  
   for different coals, 827  
   for house heating, 690  
   gas, fuel for, 854  
   hot-air, heating by, 690  
   industrial, temperatures in, 554  
   open hearth, temperature in, 554, 555  
   steam-boiler (*see* Boiler-furnaces)  
   steam-boiler, combustion space in, 889



- Fusible alloys, 404  
 plugs in boilers, 404, 918
- Fusibility of metals, 180
- Fusing-disk, 1309  
 temperatures of substances, 554, 559
- Fusion, latent heat of, 568  
 of electrical wires, 1409
- g*, value of, 522, 525
- G**AGE, decimal, 32  
 lines for steel angles, 321  
 sheet metal, 28, 29, 31, 32  
 Stub's wire, 28,
- Gages, limit, for iron for screw threads, 232  
 wire, 28-30
- Gallon, British and American, 27
- Gallons and cubic feet, table, 130  
 per minute, cubic feet per second, 130
- Galvanic action, corrosion by, 467
- Galvanized sheets, weights of, 192  
 wire, test for, 474  
 wire rope, 255, 262
- Galvanizing by cementation, 474  
 iron surfaces, 473, 474  
 of welded pipe 206
- Gas** (*see also* Fuel-gas, Water-gas, Producer gas, Illuminating-gas)  
 ammonia, properties of, 1339  
 analyses by volume and weight, 854  
 and electric lighting, 1468  
 and oil engines, rules for testing, 1105  
 and vapor mixtures, laws of, 604  
 anthracite, 845  
 bituminous, 846  
 carbon, 845  
 coal, 858  
 exhausters, rotary, 679  
 fuel (*see also* Water-gas)  
 fuel, cost of, 863  
 fuel for small furnaces, 854  
 flow of, in pipes, 864-866 (*see* Flow of gas)  
 illuminating, 858-866 (*see* Illuminating-gas)  
 lamps, pipe services for, 864  
 lights, candle-power of, 860  
 lights, Welsbach, standard sizes, 1474  
 meter, Thomas electric, 667, 669  
 natural, 847-848  
 perfect, equations of a, 600  
 pipe, cast-iron, weights and dimensions, 198, 199  
 produced from ton of coal, 848  
 producer, 848-855 (*see also* Gas-Producers)  
 sulphur-dioxide, properties of, 1338, 1341  
 table of factors for equivalent volumes of, 865
- Gas, water, 846, 859-864 (*see* Water-gas)
- Gases, absorption of, 605  
 Avogadro's law of, 604  
 combustion of, rise of temperature in, 818  
 cupola, utilization of, 1253  
 densities of, 604  
 expansion of, 601, 603  
 expansion of by heat, table, 565  
 flow of, 605  
 heat of combustion of, 560  
 ignition temperature of, 858  
 law of Charles, 600, 604  
 liquefaction of, 605  
 Mariotte's law of, 603  
 of combustion, analyses of, 817  
 physical properties of, 603-606  
 specific heats of, 563, 564  
 waste, use of, under boilers, 898, 899  
 weight and specific gravity of, table, 176
- Gas-engine**, 1095-1108  
 calculation of the power of, 1097  
 conditions of maximum efficiency, 1103  
 economical performance of, 1104  
 efficiency of, 1103  
 four-cycle and two-cycle, 1096  
 governing, 1103  
 heat losses in, 1104  
 horse-power, estimate of, 1101  
 ignition in, 1102  
 mean effective pressure in, 1098  
 pressures developed in, 1097  
 pumps, 808  
 sizes of, 1100  
 temperatures and pressures in, 1096, 1099  
 tests of, 1105-1108  
 tests with different coals, 853
- Gas-producers**, capacity of, 851  
 and scrubbers, proportions of, 849  
 combustion in, 849  
 practice, 851  
 use of steam in, 854
- Gasoline engines, 1101  
 fuel value of, 841  
 vapor pressures of, 844
- Gauss, definition and value of, 1398
- Gear**, reduction, for steam turbines, 1095  
 reversing, 1039  
 stub-tooth, 1167,  
 wheels, calculation of speed of, 1162  
 wheels, formulæ for dimensions of, 1160  
 wheels, milling cutters for, 1162  
 wheels, proportions of, 1161  
 worm, 540
- Gears, automobile, efficiency of, 1172  
 lathe, for screw cutting, 1259  
 of lathes, quick change, 1260

- Gears, spur, machine-cut, 1178  
with short teeth, 1160
- Gear-box drive for machine tools, 1308  
-cutting, speeds and feeds for, 1284
- Gearing, annular, 1169  
bevel, 1169  
chordal, pitch, 1159  
comparison of formulæ, 1174-1177  
cycloidal teeth, 1162  
diameters for 1-inch circular pitch, 1159  
differential, 1169  
efficiency of, 1170-1172  
forms of teeth, 1162-1167  
frictional, 1178  
involute teeth, 1165  
pitch, pitch-circle, etc., 1157  
proportions of teeth, 1159, 1161  
racks, 1165  
raw-hide, 1177  
relation of diametral and circular pitch, 1158  
speed of, 1177  
spiral, 1168  
stepped, 1168  
strength of, 1172-1177  
stub-tooth, 1167  
toothed-wheel, 539, 1157-1180  
twisted, 1168  
worm, 1168  
worm, efficiency of, 1171
- Generator sets, standard dimensions of, 1007
- Generators, acetylene, 857  
alternating-current, 1448 (*see* Dynamo electric machines)  
electric, 1437, 1448
- Geometrical problems, 37-53  
progression, 11  
propositions, 53
- Geometry, analytical, 70-73
- German silver, 356, 402  
conductivity of, 1401
- Gesner process, treating iron surfaces, 473
- Gib keys, 1332
- Gilbert, unit of magneto-motive force, 1398
- Girder beams, Bethlehem steel, 331
- Girders, allowed stresses in plate and lattice, 289  
and beams, safe load on, 1387  
and beams, New York building laws, 1390  
plate, strength of, 353  
Warren, stresses in, 546
- Glass, skylight, sizes and weights, 196  
strength of, 365  
weight of, 177
- Gold, melting temperature of, 554, 559  
properties of, 178
- Gordon's formula for columns, 284
- Governor, inertia, 1066
- Governors, steam-engine, 1065-1068
- Governing of gas-engines, 1103
- Grade line, hydraulic, 748
- Grain, weight of, 180
- Granite, strength of, 357, 370
- Graphite, Acheson's deflocculated, 1246  
lubricant, 1246  
paint, 471
- Grate-surface, for house heating, boilers and furnaces, 693  
in locomotives, 1115  
of a steam-boiler, 888
- Gravel, cubic feet per ton, 181
- Gravity, acceleration due to, 521, 525  
boiler-feeders, 938  
center of, 516  
specific (*see* Specific gravity), 173-175
- Grease lubricants, 1244
- Greatest common measure or divisor, 2
- Greek letters, 1
- Greenhouses, hot-water, heating of, 703  
steam-heating of, 702
- Grinding as a substitute for finish turning, 1317  
of tools, 1263  
wheel (*see* Grindstones and Emery wheels)  
wheel for high-speed tools, 1263, 1314
- Grindstones, speed of, 1317  
strains in, 1318
- Guest's formula for combined stresses, 335
- Gun-bronze, variation in strength of, 386
- Gun-iron, variation in strength of, 452
- Gun-metal (bronze), composition of, 390
- Guns, energy of recoil of, 531
- Gurley's bronze, composition of, 390
- Guy ropes for stand-pipes, 349  
ropes, wire, 255
- Gyration, center of, 518  
radius of, 293  
table of radii of, 519
- H**-COLUMNS, Bethlehem steel, 333  
Halpin heat storage system, 927, 1014
- Hammering, effect of, on steel, 488
- Hanger bolts, 243
- Hardening and tempering, change of shape due to, 1291  
of soft steel, 479
- Hardness, electro-magnetic tests of, 365  
of copper-tin alloys, 385

- Hardness of metals, Brinell's tests, 364  
 of water, 723  
 scleroscope tests of, 365
- Harvey process of hardening steel, 1291
- Harveyizing steel armor-plate, 1291
- Haulage, wire-rope, 1202-1205  
 wire-rope, endless rope system, 1203  
 wire-rope, engine-plane, 1203  
 wire-rope, inclined-plane, 1202  
 wire-rope, tail-rope system, 1203  
 wire-rope tramway, 1204
- Hauling capacity of locomotives, 1111
- Hawley down-draught furnace, 919
- Hawsers, steel wire, 262
- Hazen & Williams' formula, table of flow of water, 742, 743
- Head, loss of, 728, 735, 745 (*see* Loss of head)  
 of air, due to temperature differences, 716  
 of water, 728  
 of water, comparison of, with various units, 718
- Heads of boilers, 914  
 of boilers, unbraced, wrought iron, strength of, 337
- Heat**, 549-597  
 conducting power of metals, 580  
 conduction by various substances, 580-587  
 conduction of, 579  
 convection of, 579  
 effect of on grain of steel, 479  
 expansion due to, 565  
 generated by electric current, 1408  
 -insulating materials, tests of, 581  
 latent, 568 (*see* Latent heat)  
 loss by convection, 596  
 losses in steam-power plants, 1012  
 mechanical equivalent of, 560, 868  
 of combustion, 560  
 of combustion of fuels, 560, 817  
 produced by human beings, 686  
 quantitative measurement of, 560  
 radiating power of substances, 578  
 radiation of, 578 (*see also* Radiation)  
 reflecting power of substances, 578  
 resistance, coefficients of, 583  
 resistance, reciprocal of conductivity, 582  
 specific, 562-565 (*see* Specific heat)  
 steam, storing of, 927, 1014
- Heat storage, Halpin system, 927, 1014
- Heat transmission**, Blechynden's tests of, 593  
 from flame to water, 592  
 from gases to water, 592  
 from steam to water, 587  
 in condenser tubes, 589  
 in feed-water heater, 590  
 in radiators, 698  
 resistance of metals to, 580  
 through building walls, etc., 582, 688  
 through plates, 580, 591  
 through plates from steam or hot water to air, 595
- Heat treatment of a motor-truck axle, 479  
 treatment of high speed tool steel, 1265  
 treatment of steel (*see* Steel)  
 unit of, 560, 867  
 units per pound of water, 717
- Heaters and condensers, calculation of surface of, 939  
 cast iron, for hot-blast heating, 709  
 cast iron, tests of, 709  
 electric, 1420  
 feed-water, 938-940  
 feed-water, open-type, 940  
 feed-water, transmission of heat in, 590
- Heating and Ventilation**, 681-716  
 allowance for exposure and leakage, 688  
 blower system, 708-710  
 boiler heating surface, 694  
 computation of radiating surface, 698  
 heating surface, indirect, 698  
 heating value of radiators, 684, 697  
 quantity of heat required, 690  
 steam-heating, 694-703 (*see* Steam-heating)  
 transmission of heat through building walls, 688
- Heating a building to 70° in zero weather, 711  
 air, heat absorbed in, 691  
 and ventilating by electric current, 1421  
 by blower system, capacity of fans for, 711  
 by electricity, 713  
 by exhaust steam, 1009  
 by hot-air furnaces, 690  
 by hot water, 703-708 (*see* Hot-water heating)  
 by overhead steam pipes, 702  
 by steam (*see* Steam-heating)  
 domestic, by electricity, 1421  
 furnace, size of air pipes for, 692  
 furnace, with forced air supply, 690  
 guarantees, performance of, 712  
 of electrical conductors, 1408



- Heating of factories by blower system, 708, 710  
   of greenhouses, 702  
   of large buildings, 684  
   of steel for forging, 492  
   of tool steel, 492  
   problems, standard values in, 687  
   steam and electric, 1421  
   value of coals, 826-830  
   value of wood, 835  
   water by steam coils, 591
- Heating-surface of steam-boiler, 887, 888
- Height, table of, corresponding to a given velocity, 523
- Helical steel springs, 418
- Helix, 61
- Hemp rope, strength of, 357  
   rope, table of strength and weight of, 410, 415
- Henry, definition and value of, 1397
- High-speed tool steel (*see* Steel, and Tools)
- Hindley worm gear, 1169
- Hobson's hot-blast pyrometer, 555
- Hodgkinson's formula for columns, 283
- Hoists, electric motors for, 1464
- Hoisting** by hydraulic pressure, 813  
   counterpoise system, 1189  
   cranes, 1189-1193 (*see* Cranes)  
   effect of slack rope, 1186  
   endless rope system, 1189  
   engines, 1186  
   engines, compressed-air, 646  
   engines, counterbalancing of, 1188  
   horse-power required for, 1184  
   Koepe system, 1189  
   loaded wagon system, 1189  
   limit of depth for, 1186  
   of cargoes, 414  
   pneumatic, 1187  
   suspension cableways, 1205  
   with tapering ropes, 1188
- Hoisting-rope**, 410-415  
   flexible steel wire, 258, 259  
   iron or steel, tables, 255-261  
   non-spinning, 258, 261  
   stresses in, on inclined planes, 1204  
   tension required to prevent slipping, 1206  
   wire, sizes and strength of, 410,
- Holding power** of bolts in white pine, 346  
   of expanded boiler tubes, 364  
   of lag-screws, 347  
   of nails in wood, 347  
   of nails, spikes and screws, 346, 347  
   of tubes expanded into sheets, 364  
   of wood screws, 346
- Holes, tube, in steam-boilers, 916
- Hollow cylinders, resistance of to collapse, 341-345  
   shafts, torsional strength of, 334
- Homogeneity test for fire-box steel, 508
- Hooks and shackles, strength of, 1184  
   heavy crane, 1183  
   proportions of, 1182
- Horse gin, 534  
   work of, 533
- Horse-power** (*see also* Power)  
   brake, 970  
   brake, definition of, 1017  
   computed from torque, 1436  
   constants, of steam-engines, 971-974  
   definition of, 27, 528  
   electrical, 970, 1408  
   electrical, brake and indicated, 1408  
   hours, definition of, 528  
   nominal, definition of, 974  
   of compound engine, estimating, 971  
   of flowing water, 765  
   of marine and locomotive boilers, 888  
   of steam-boilers, 885  
   of steam-boilers, builders' rating, 888  
   of steam-engines, 970-976  
   water and steam, cost of, 767
- Hose couplings, national standard, 218  
   fire, friction losses in, 752  
   hydrant pressures required with different lengths of, 750  
   rubber-lined, friction loss in, 752  
   specifications for, 379
- Hot-air engines, 1095  
   heating (*see* Heating)
- Hot-blast pyrometer, Hobson's, 555
- Hot-blast system of heating, 708 (*see* Heating)
- Hot boxes, 1228
- Hot-water Heating** (*see* Heating), 703-708  
   arrangement of mains, 703  
   computing radiating surface, 704-706  
   corrosion of pipe in, 708  
   indirect, 705  
   of greenhouses, 703  
   rules for, 703  
   size of pipes for, 704  
   sizes of flow and return pipes, 707  
   velocity of flow, 703  
   with forced circulation, 707
- House-heating (*see* Heating)
- House-service pipes, flow of water in, table, 744
- Howden system of forced draught, 923

- Howe truss, stresses in, 546  
 Humidity and temperature, comfortable, 685  
   relative, table of, 610  
 Humphrey gas pump, 808  
 Hyatt roller bearings, 1235  
 Hydraesfer process, treating iron surfaces, 473  
 Hydrant pressures required with different lengths of hose, 750  
**Hydraulic** air compressor, 650  
   apparatus, efficiency of, 812  
   cylinders, thickness of, 813  
   engine, 815  
   forging, 814, 815  
   formulæ, 726-746  
   formulæ, approximate, 734, 737, 746  
   grade-line, 748  
   packing, friction of, 813  
   pipe, riveted, table, 219  
   power in London, 814  
   press, thickness of cylinders for, 340  
   presses in iron works, 813  
   ram, 810-812  
   riveting machines, 814  
 Hydraulics (*see* Flow of water)  
**Hydraulic pressure**, hoisting by, 813  
   transmission, 812-816  
   transmission, energy of, 812  
   transmission, speed of water through pipes and valves, 813  
   transmission, references, 816  
 Hydrometer, 175  
 Hygrometer, dry and wet bulb, 610  
 Hyperbola, asymptotes of, 73  
   construction of, 49  
   equations of, 72  
 Hyperbolic curve on indicator diagrams, 974  
   logarithms, tables of, 164-166  
 Hypocycloid, 50
- I-BEAMS** (*see also* Beams)  
   Bethlehem steel, 332  
   Carnegie, table of, 307-310  
   safe loads on, 309  
   spacing of, for uniform load, 311
- Ice-making, absorption evaporator system, 1367  
   machines, 1336-1367 (*see* Refrigerating machines)  
   plant, test of, 1367  
   tons of ice per ton of coal, 1367  
   with exhaust steam, 1367  
 Ice, manufacture, 1366  
   -melting effect, 1343  
   properties of, 720  
   strength of, 368  
 Ignition in gas engines, 1102  
   temperature of gases, 858  
**Illuminants**, relative color values of, 1469  
**Illuminants**, relative efficiency of, 1472  
**Illuminating coal-gas**, 858  
**Illuminating-gas**, 858-866  
   calorific equivalents of constituents, 860  
   fuel value of, 863  
   space required for plants, 862  
**illuminating water-gas**, 859  
**illumination** by arc lamps at different distances, 1471  
   definition of, 1468  
   electric and gas lighting, 1468  
   interior, 1473  
   of buildings, watts per square foot, required for, 1369  
   relation of, to vision, 1469  
**Impact**, 530  
**Impedance**, 1441  
   polygons, 1442  
**Impulse water wheels**, 779 (*see* Water wheel, tangential)  
**Impurities of water**, 720  
**Incandescent lamps** (*see* Lamps), 1470  
**Inches and fractions as decimals of a foot**, table, 5  
**Inclined-plane**, 527, 537  
   motion on, 527  
   stresses in hoisting ropes on, 1204  
   wire-rope haulage, 1202  
**Incrustation and scale**, 721, 927-932  
**India rubber**, action under tension, 378  
   vulcanized, tests of, 378  
**Indicated horse-power**, 970-976  
**Indicator diagrams**, analysis of, 1017  
   diagrams, to draw clearance line on, 974  
   diagrams, to draw expansion curve, 974  
   diagrams, tests of locomotives, 1122  
   rig, 969  
**Indicators**, steam-engine, 968-976 (*see* Steam-engines)  
   steam-engine, errors of, 969  
**Indirect heating radiators**, 698  
**Inductance**, 1440  
   of lines and circuits, 1445  
**Induction**, magnetic, 1398  
   motors, 1463  
**Inertia**, definition of, 513  
   moment of, 293, 517  
**Ingot iron**, "Armco," 477  
**Injector**, 807  
   efficiency of, 937  
   equation of, 936  
   performance of, 937  
**Inspection of steam-boilers**, 932  
**Insulation**, underwriters', 1410  
**Insulators**, electrical value of, 1402  
   heat, 581  
**Integrals**, 75  
   table of, 80, 81

- Integration**, 76  
**Intensity of magnetization**, 1398  
**Interest**, 12  
   compound, 13, 14  
**Intercoolers for air compressors**, 648  
**Interpolation**, formula for, 86  
**Invar**, iron-nickel alloy, 499, 567  
**Involute**, 52  
   gear-teeth, 1165  
   gear-teeth, approximation of, 1166  
**Involution**, 7  
**Iridium**, properties of, 178  
**Iron and steel**, 178, 436-511  
   classification of, 436  
   effect of cold on strength of, 464  
   electric furnaces, 1423  
   inoxidizable surface for, 472  
   preservative coatings for, 471-474  
   relative corrosion of, 468  
   rustless coatings for, 471-474  
   sheets, weight of, 183  
   tensile strength at high temperatures, 463  
**Iron bars** (*see* Bars)  
   bars, weight of square and round, 181, 184  
   bridges, durability of, 466  
   cast, 437-454 (*see* Cast-iron)  
   castings, chemical standards for, 441  
   coated with aluminum, 473  
   coated with lead, 474  
   coefficients of expansion of, 465  
   color of at various temperatures, 558  
   -copper-zinc alloys, 393  
   corrosion of, 467  
   corrugated, sizes and weights, 194  
   durability of, 465-467  
   electrolytic, properties of, 460  
   flat-rolled, weight of, 188, 189  
   for stay-bolts, 462  
   inoxidizable surfaces, production of, 472  
   latent heat of fusion of, 568  
   malleable, 454 (*see* Malleable iron)  
   pig (*see* Pig-iron and Cast-iron)  
   plates, approximating weight of, 486  
   plates, weight of, table, 187  
   properties of, 178  
   rivets, shearing resistance of, 430  
   rope, table of strength of, 410  
   shearing strength of, 362  
   sheets, weights, 31, 32, 183  
   -silicon-aluminum alloys, 398  
   specific heat of, 562, 563  
   tubes, collapsing pressure of, 341  
   wrought, 459-463 (*see* Wrought iron)
- Irregular figure**, area of, 56, 57  
   solid, volume of, 65  
**Irrigation canals**, 755  
**Isothermal compression of air**, 633  
   expansion, 601  
   expansion of steam, 959
- JAPANESE alloys**, composition of, 393  
   Jarno tapers, 1319  
**Jet condensers**, 1068  
   propulsion of ships, 1384  
   reaction of a, 1385  
**Jets**, steam (*see* Steam Jets)  
   vertical water, 749  
**Joints**, pipe (*see* Pipe joints)  
   riveted, 424-435 (*see* Riveted joints)  
**Joists**, contents of, 21  
**Joule**, definition and value of, 1396, 1397  
**Joule's equivalent**, 560  
**Journals** (*see also* Shafts and Bearings)  
   coefficients of friction of, 1220  
**Journal-bearings**, cast-iron, 1223  
   friction of, 1220-1232  
   of engines, 1034
- KAO LIN**, melting point of, 556  
   Kelvin's rule for electric transmission, 1411  
**Kennedy key**, 1330  
**Kerosene as fuel**, 841  
   for scale in boilers, 929  
**Keys**, dimensions of, 1328  
   gib, 1332  
   holding power of, 1332  
   various forms of, 1328  
**Key-seats**, depth of, 1329  
**Keyways for milling cutters**, 1277  
**Kinetic energy**, 528  
**King-post truss**, stresses in, 543  
**Kirkaldy's tests of strength of materials**, 352-358  
**Knife-edge bearings**, 1238  
**Koepe's system of hoisting**, 1189  
**Knot**, on nautical mile, 17  
**Knots**, varieties of, 415, 416  
**Krupp steel tires and axles**, 354  
**Kutter's formula**, flow of water, 730  
   formula, tables of flow of water, 738, 739
- LACING of belts**, 1147  
   Ladles, foundry, sizes of, 1257  
**Lag screws**, holding power of, 347  
   screws, sizes and weights, 241  
**Lamps**, arc, 1470  
   arc, data of, 1471  
   arc, illumination by, at different distances, 1471  
   arrangement of, in rooms, 1475  
   electric, life of, 1476  
   incandescent, characteristics of, 1474  
   incandescent electric, 1470



- Lamps, mercury vapor, 1470  
tungsten, 1473
- Land measure, 17
- Lang-lay wire-rope, 254
- Lap and lead in slide valves, 1052-1054
- Lap joints, riveted, 426, 427
- Laps and lapping, 1310
- Latent heat** of evaporation, 569  
of fusion of iron, 568  
of fusion of various substances, 568
- Lathe**, change-gears for, 1260  
cutting speed of, 1259  
horse-power to run, 1292, 1293  
power required for, 1293  
rules for screw-cutting gears, 1259  
setting taper in, 1261  
tools, forms of, 1261
- Lattice girders, allowed stresses in, 289
- Laws of falling bodies, 521  
of motion, 513
- Lead** and tin tubing, 226, 227  
coatings on iron surfaces, 474  
effect of, on copper alloys, 394  
-lined iron pipes, 227  
paint as a preservative, 471  
pipe, tin-lined, sizes and weights, table, 226  
pipe, weights and sizes of, table, 226, 227  
properties of, 178  
sheet, weight of, 228  
waste-pipe, weights and sizes of, 227
- Leakage of steam in engines, 976
- Least common multiple, 2
- Leather, strength of, 357
- Lea-Deagan two-stage pump, test of, 801
- Le Chatelier's pyrometer, 554
- Lentz compound, engine, 997
- Leveling by barometer, 607  
by boiling water, 607
- Lever, 535  
bent, 514, 536
- Lewis's key, 1329
- Lighting, electric and gas, 1468  
electric, cost of, 1475  
of streets, 1471  
quantity of gas and electricity required for different rooms, 1473  
street, recent installations, 1476
- Lightning protection of chimneys, 949
- Lights (*see* Lamps)
- Lignites, analysis of, 829
- Lime and cement mortar, strength of, 372  
and cement, weight of, 180
- Limestone, strength of, 371
- Limit, elastic, 273-278  
gages for screw-thread iron, 232
- Lines of force, 1430
- Links, steel bridge, strength of, 353
- Link-beltting, sizes and weights, 1199
- Link-motion, locomotive, 1119  
steam-engine, 1062-1065
- Lintels in buildings, 1390
- Liquation of metals in alloys, 388
- Liquefaction of gases, 605
- Liquid air and other gases, 605, 606  
measure, 18
- Liquids, absorption of gases by, 605  
compressibility of, 175  
expansion of, 567  
specific gravity of, 175  
specific heats of, 563
- Loading and storage machinery, 1193
- Lock-joints for pipes, 212
- Locomotive** boilers, 1113  
boiler tubes, seamless, 222  
boilers, size of, 1113  
crank-pin, quantity of oil used on, 1246  
engine performance, 1122  
forgings, strength of, 353
- Locomotives**, 1108-1129  
boiler pressure, 1117  
classification of, 1116  
compounding of, 1125  
compressed-air, 1128  
compressed-air, with compound cylinders, 1129  
counterbalancing of, 1126  
dimensions of, 1120-1122  
drivers, sizes of, 1118  
economy of high pressure in, 1116  
effect of speed on cylinder pressure, 1117  
efficiency of, 1111  
exhaust-nozzles, 1115  
fire-brick arches in, 1115  
fireless, 1127  
fuel efficiency of, 1119  
fuel waste of, 1125  
grate-surface of, 1115  
hauling capacity of, 1111  
horse-power of, 1113  
indicator tests of, 1122  
leading types of, 1116  
light, 1127  
link-motion, 1119  
Mallet compound, 1120  
narrow gage, 1127  
performance of high speed, 1118  
petroleum burning, 1127  
safety valves for, 935  
smoke-stacks, 1115  
speed of, 1118  
steam distribution of, 1117  
steam-ports, size of, 1118  
superheating in, 1126  
testing, 1123  
tractive force of, 1112. 1125  
types of, 1116  
valve travel, 1118  
water consumption of, 1122  
weight of, 1124

- Locomotives, Wootten, 1114  
 Logarithmic curve, 73  
   ruled paper, 84  
   sines, etc., table, 167  
 Logarithms, 79  
   four-place, table, 168  
   hyperbolic, tables of, 164-166  
   six-place, table, 137-164  
   use of, 135-137  
 Logs, area of water required to  
   store, 181  
   lumber, etc., weight of, 181  
   weight of, 181  
 Long measure, 17  
 Loop, steam, 883  
 Loops of force, 1430  
 Lord and Haas's tests of coal,  
   822, 823  
 Loss and profit, 12  
   of head, Cox's formula, 734  
   of head in cast-iron pipe, tables,  
     745  
   of head in flow of water, 728,  
     735, 745  
   of head in riveted steel pipes, 735  
 Lowmoor iron bars, strength of,  
   352  
 Lubricant, water as a, 1246  
**Lubricants**, examination of, 1242  
   grease, 1244  
   measurement of durability, 1241  
   oil, specifications for, 1242  
   qualifications of good, 1242  
   relative value of, 1242  
   soda mixture, 1246  
   solid, 1246  
   specifications for petroleum,  
     1242  
 Lubrication, 1241-1246  
   of engines, quantity of oil  
     needed for, 1245  
   of steam-engine cylinders, 1245  
 Lumber, weight of, 181  
 Lumen, definition of, 1469  
 "Lusitania," performance of,  
   1376, 1381  
   turbines and boilers of, 1381  
 Lux, definition of, 1469
- M**ACHINE screws, A. S. M.  
   E. standard, table, 234-  
     237  
   screws, taps for, 1320  
   shop, 1258-1333  
   shops, electric motors for, 1294-  
     1308, 1466  
**Machine tools**, drives, feeds and  
   speeds, 1307  
   electric motors for, 1294-1308,  
     1466  
   gear connections of, to motors,  
     1301  
   individual motors for driving,  
     1308  
   methods of driving, 1307  
   power required for, 1270, 1278,  
     1286, 1293  
   sizes of motors for, 1294
- Machine tools, soda mixture for,  
   1246  
   speed of, 1258  
 Machines, dynamo-electric (*see*  
   Dynamo-electric-machines)  
   efficiency of, 532  
   elements of, 535-541  
   in groups, power required for  
     driving, 1305  
 Machinery, coal-handling, 1196-  
   1199  
   horse-power required to run,  
     1292-1308  
 Maclaurin's theorem, 78  
 Magnalium, magnesium-alumi-  
   num alloy, 399  
 Magnesia bricks, 269  
 Magnesite, analysis of, 270  
 Magnesium, properties of, 179  
 Magnet, electro, 1430  
 Magnets, lifting, 1193  
**Magnetic** alloys, 402  
   balance, for testing steel, 483  
   brakes, 1240  
   capacity of iron and steel, ef-  
     fect of annealing on, 483  
   circuit, 1430  
   circuit, units of, 1398  
   field, 1398  
   field, strength of, 1436  
   flux, magnetic induction, 1398  
   moment, 1398  
   pole, unit of, definition, 1398  
 Magnetization, intensity of, 1398  
 Magneto-motive force, 1398  
 Magnolia metal, composition of,  
   405  
 Mahler's calorimeter, 826  
 Malleability of metals, table, 180  
**Malleable** cast iron, 454  
   castings, annealing, 455  
   castings, design of, 457  
   castings, tests of, 458  
   iron, pig iron for, 454  
   iron, composition and strength  
     of, 454, 458  
   iron, improvement in quality,  
     458  
   iron, physical characteristics, 456  
   iron, shrinkage of, 455  
   iron, specifications, 457  
   iron, strength of, 454, 458  
   iron test bars, 457  
 Mandrels, standard steel, 1318  
 Manganese bronze, 401  
   -copper alloys, 401  
   effect of, on cast iron, 438, 450  
   effect of, on steel, 476  
   properties of, 179  
   steel, 494  
   sulphide, dangerous in steel, 486  
 Manganin, high resistance alloy,  
   404, 1402  
 Manhole openings in steam-  
   boilers, 914  
 Manila rope, 411  
   rope, weight and strength of,  
     410-415

- Manograph, a high-speed engine-indicator, 969
- Manometer, air, 607  
work of, tables, 532, 533
- Man-wheel, 533
- Marble, strength of, 357
- Marine engineering, 1368-1385  
(*see* Ships and Steam-engines)  
engine, internal combustion, 1374  
engine practice, advance in, 1380
- Mariotte's law of gases, 603
- Martensite, 439, 480
- Masonry, allowable pressures on, 1386  
crushing strength of, 371  
materials, weight and specific gravity of, 177
- Mass, definition of, 511
- Materials, 173-273  
standard cross-sections, for draftsmen, 271  
strength of, 272-379  
strength of, Kirkaldy's tests, 352-358  
various, weights of, table, 181
- Maxima and minima, 78, 79
- Maxwell, definition and value of, 1398
- Measures** and weights, compound units, 27  
and weights, metric system, 21-26  
apothecaries, 19  
board and timber, 20  
circular, 20  
dry, 19  
liquid, 18  
long, 17  
nautical, 17  
of work, power and duty, 27  
old land, 17  
shipping, 19, 1316  
solid or cubic, 18  
square, 18  
surface, 18  
time, 20
- Measurement of air velocity, 624  
of elongation, 279  
of flowing water, 757-764  
of vessels, 1368
- Measurements, miner's inch, 761
- Mechanics, 511-548
- Mechanical equivalent of heat, 560, 868  
and electrical units, equivalent values of, 1399  
powers, 535  
stokers, 918
- Mekarski compressed-air tramway, 652
- Melting-points of substances, temperatures, 554, 559
- Mensuration, 54-66
- Mercurial thermometer, 549
- Mercury-arc rectifier, 1456
- Mercury-bath pivot, 1233  
properties of, 179
- Mercury vapor lamp, 1469
- Mesuré and Nouel's pyrometric telescope, 556
- Metacenter, definition of, 719
- Metals**, anti-friction, 1223  
coefficients of expansion of, 566  
coefficients of friction of, 1220  
electrical conductivity of, 1401  
flow of, 1323  
heat-conducting power of, 580  
life of, under shocks, 276  
properties of, 177-180  
resistance overcome in cutting of, 1292  
specific gravity of, 174  
specific heats of, 562, 563  
table of ductility, infusibility, malleability and tenacity, 180  
tenacity of, at various temperatures, 463  
weight of, 174
- Metaline lubricant, 1246
- Metallography, 480
- Meter, Thomas electric, for measuring gas, 667, 669  
Venturi, 758  
water, V-notch recording, 759
- Meters, water delivered through, 749
- Methane gas, physical laws of, 604
- Metric conversion tables, measures and weights, 21-26  
screw-threads, cutting of, 1261
- Microscopic constituents of cast iron and steel, 439, 480
- Mil, circular, 18, 29.
- Mill buildings, columns, 1393  
buildings, approximate cost of, 1394  
power, 766
- Milling cutters**, diameter, clearance and rake of, 1278  
for gear-wheels, 1162  
inserted teeth, 1276  
keyways in, 1277  
lubricant for, 1281  
number of teeth in, 1276  
side, 1275  
spiral, 1275
- Milling, high-speed, 1282  
jobs, typical, 1281  
machines, cutting speed of, 1280, 1284  
machines, high results with, 1282  
machines, typical jobs on, 1281  
power required for, 1278  
practice, modern, 1279, 1283  
with or against the feed, 1280
- Mine fans, experiments on, 673  
ventilating fans, 673  
ventilation, 714
- Mines, centrifugal fans for, 672
- Miner's inch, 18  
inch measurements, 761
- Modulus of elasticity, 274  
of elasticity of various materials 374



- Modulus of resistance, or section  
   modulus, 294  
   of rupture, 297  
 Moisture in atmosphere, 609-613  
   in steam, determination of, 942-  
   944  
   in steam escaping from boilers,  
   944  
 Molding-sand, 1256  
 Molds, cast-iron, for iron castings,  
   analysis of, 1256  
 Moment of a couple, 515  
   of a force, 514  
   of friction, 1229  
   of inertia, 293, 295, 517  
   statical, 514  
 Moments, method of, for deter-  
   mining stresses, 545  
   of inertia of regular solids, 517  
   of inertia of structural shapes,  
   295  
 Momentum, 527  
 Mond gas producer, 852  
 Monel metal, copper-nickel alloy,  
   403  
 Monobar chain conveyor, 1197  
 Morin's laws of friction, 1223  
 Morse tapers, 1319  
 Mortar, strength of, 372  
 Motion, accelerated, formulæ for,  
   527  
   friction of, 1219, 1221  
   Newton's laws of, 513  
   on inclined planes, 527  
   perpetual, 532  
   retarded, 521  
**Motor** applications, 1464-1468  
   boats, power of engines for, 1374  
   -driven machine tools, 1308  
   generators, 1456  
   repulsion, induction, 1464  
   squirrel-cage, 1463  
   temperatures, limits of, 1432  
**Motors**, alternating-current, 1463  
   commutating pole, 1437  
   compressed-air, 639-641  
   electric (*see* Electric motors)  
   electric, classification of, 1461  
   gear connections of, for machine  
   tools, 1301  
   sizes of, for machine tools, 1294  
   water current, 765  
 Moving strut, 536  
 Mule, work of, 534  
 Multiphase electric currents, 1445  
 Multiple system of evaporation,  
   570  
 Multivane fans, 658  
 Muntz metal, composition of, 390  
 Mushet steel, 496  
**NAILS**, cut, table of sizes and  
   weights, 244  
   cut *vs.* wire, 347  
   holding power of, 346  
   wire, table of sizes and weights,  
   246, 247  
 Nail-holding power of wood, 347  
 Naphtha as fuel, 841  
 Napier's rule for flow of steam,  
   876  
 Natural gas, 847, 848  
 Nautical measure, 17  
   mile, 17  
 Newton's laws of motion, 513  
 Nickel, effect of on properties of  
   steel, 498  
 Nickel, properties of, 179, 379  
   steel, 497  
   steel, tests of, 497  
   steel, uses of, 498  
 Nickel-copper alloys, 402  
   -vanadium steels, 499  
 Niter process, treating iron sur-  
   faces, 473  
 Nordberg feed-water heating sys-  
   tem, 1003  
   key, 1331  
   pumping-engine, 805  
 Nozzles, flow of steam through,  
   876, 1085  
 Nozzles, flow of water in, 753  
   for measuring discharge of  
   pumping-engines, 759  
   water, efficiency of, 784  
 Nut and bolt heads, thickness of,  
   231  
**OATS**, weight of, 180  
 Ocean waves, power of, 786  
 Oersted, unit of magnetic  
   reluctance, 1398  
 Ohm, definition and value of, 1397  
 Ohm's law, 1406  
   law applied to alternating cur-  
   rents, 1442  
   law applied to parallel circuits,  
   1407  
   law applied to series circuits,  
   1407  
**Oil** as fuel (*see* Fuel Oil), 842, 843  
   -engines, 1102  
   fire-test of, 1243  
   for scale removal in boilers, 930  
   for steam turbines, 1244  
   fuel, chimney draught with, 952  
   fuel, chimney table for, 951  
   lubricating, 1242-1245 (*see* Lub-  
   ricants)  
   paraffine, 1243  
   pressure in a bearing, 1228  
   quantity needed for engines,  
   1245  
   tempering of steel forgings, 482  
   *vs.* coal as fuel, 842, 843  
   well, 1243  
   wells, air-lift pump for, 809  
 Open-hearth, steel (*see* Steel,  
   open-hearth), 475  
   furnace, temperatures in, 554  
 Ordinates and abscissas, 70  
 Ores, cubic feet per ton, 181  
 Orifice, equivalent, in mine ven-  
   tilation, 715  
   flow of air through, 615-617,  
   670

- Orifice, flow of water through, 726  
 rectangular, flow of water through, table, 760
- Oscillation, center of, 518  
 radius of, 518
- Overhead steam-pipe radiators, 702
- Ox, work of, 534
- Oxy-acetylene welding, 488
- Oxygen, effect of on strength of steel, 477
- $\pi$  value and relations of, 57
- P**ACKING, hydraulic, friction of, 1241  
 -rings of engines, 1023
- Paddle-wheels, 1383
- Paint, 471  
 chrome, preventing corrosion, 469  
 for roofs, 192  
 qualities of, 472  
 quantity of, for surface, 472
- Paper, logarithmic ruled, 84
- Parabola, area of by calculus, 76  
 construction of, 48, 49  
 equations of, 72  
 path of a projectile, 525
- Parabolic conoid, 65  
 spindle, 65
- Parallel forces, 515  
 operation of motors, 1439, 1450
- Parallelogram area of, 54  
 of forces, 513  
 of velocities, 523
- Parallelepipedon of forces, 514
- Parentheses in algebra, 34
- Partial payments, 14
- Parting and threading tools, speed of, 1268
- Patterns, weight of, for castings, 1256
- Payments, equation of, 14
- Pearlite, 439, 480
- Peat, 838
- Pelton water-wheel, 779
- Pendulum, 520  
 conical, 520
- Percentage, 12
- Percussion, center of, 518
- Perforated plates, strength of, 425
- Permeability, magnetic, 1400, 1430
- Permeance, magnetic, 1400
- Permutation, 10
- Perpetual motion, 532
- Petroleum** as a metallurgical fuel, 843  
 -burning locomotives, 1127  
 cost of as fuel, 842  
 engines, 1102  
 for scale removal in boilers, 930  
 Lima, 841  
 products of distillation of, 840  
 products, specifications for, 1242  
 value of as fuel, 841
- Pewter, composition of, 407
- Phosphor-bronze, composition of, 390  
 specifications for, 395  
 springs, 424  
 strength of, 395
- Phosphorus, influence on steel, 476  
 influence of, on cast iron, 438
- Piano-wire, strength of, 250
- Pictet fluid, for refrigerating, 1337
- Piezometer, 757
- Pig-iron** (*see also* Cast iron)  
 analysis of, 439  
 charcoal, strength of, 452  
 distribution of silicon in, 448  
 electric smelting of, 1424  
 for malleable castings, 454  
 grading of, 437  
 influence of silicon, etc., on, 438  
 sampling, 443  
 specifications for, 443
- Piles, bearing power of, 1386
- Pillars, strength of, 283
- Pine, strength of, 366
- Pinions, raw-hide, 1177
- Pins, forcing fits of by hydraulic pressure, 1324
- Pins, taper, 1321
- Pipe** bends, flexibility of, 221  
 branches, compound pipes, formula for, 746  
 cast-iron, friction loss in, table, 747, 748  
 cast-iron, specifications for metal for, 441  
 cast-iron, threaded, 199  
 corrosion of in hot-water heating, 708  
 coverings, tests of, 584-587  
 dimensions, Briggs standard, 221, 222  
 fittings, flanged, 208-214  
 fittings, screwed, 207, 216  
 fittings, strength of, 216  
 fittings, valves, etc., resistance of, 701  
 flanges, extra heavy, tables, 210, 212  
 flanges, tables, 209-213  
 iron and steel, strength of, 363  
 iron, lead-, brass- and copper-lined, 227  
 iron, lead-covered, 228  
 iron, tin- and lead-lined, 227  
 joints, bell and spigot, lead required for, 199  
 lines for fans and blowers, 670  
 lines, long, 743  
 specialties, 205  
 threading of, force required for, 363  
 welded, weight and bursting strength of, 205  
 wooden stave, 218, 735
- Pipes**, *see also* Tubes  
 air-bound, 748  
 air, loss of pressure in, 617-624  
 and valves for superheated steam, 882

- Pipes, bent and coiled, 221, 222  
 block-tin, weights and sizes of, 227  
 coiled, table of, 221
- Pipes, cast-iron**, bell and spigot for gas, 198  
 flanged, for gas, 199  
 for high-pressure service, 198  
 formulæ for thickness of, 196  
 safe pressures for, tables, 196-198  
 thickness of, for various heads, 196-200  
 transverse strength of, 452  
 underground, weight of, 197  
 weight and dimensions, 196-200
- Pipes**, effects of bends in, 624, 747  
 equalization of, table 625  
 equation of, 884  
 flow of air in, 617-624  
 flow of gas in, 864-866  
 flow of steam in, 877-879  
 flow of water in, 728-746  
 for steam heating, 698  
 house-service, flow of water in, table, 744  
 iron and steel, corrosion of, 466, 467  
 lead, safe heads for, 226  
 lead, tin-lined, sizes and weights, table, 227  
 lead, weights and sizes of, table, 226  
 maximum and mean velocities in, 758  
 proportioning to radiating surface, 699, 700  
 rectangular, flow of air in, 622  
 resistance of the inlet, 735  
 rifled, for conveying heavy oils, 746  
 riveted, flanges for, table, 211  
 riveted hydraulic, weights and safe heads, table, 219  
 riveted iron, dimensions of, table, 220  
 riveted steel, loss of head in, 734  
 riveted steel, water, 351  
 sizes of threads on, 201, 217  
 spiral riveted, table of, 220  
 steam (*see* Steam-pipes)  
 steam, sizes of in steam heating, 699-701  
 table of capacities of, 131  
 used as columns, 363  
 volume of air transmitted in, table, 623, 624  
 water, loss of head in, 728, 735, 745 (*see* Loss of head)  
 welded, extra strong, 203, 204  
 welded, standard, table of dimensions, 202
- Pipe-joint, Converse lock-joint, 212  
 Matheson, 212  
 Rockwood, 212
- Piping, power-house, identification of by different colors, 885
- Piston rings, steam-engine, 1023  
 rods, steam-engine, 1024  
 valves, steam-engine, 1061
- Pistons, steam-engine, 1023
- Pitch, diametral, 1158  
 of gearing, 1157  
 of rivets, 427  
 of screw-propeller, 1377
- Pitot-tube, best form of, 667  
 gage, 757  
 measurements, accuracy of, 669  
 use in testing fans, 667
- Pivot-bearings, 1229, 1232  
 mercury bath, 1233
- Plane, inclined, 527, 537 (*see* Inclined Plane)  
 surfaces, mensuration of, 54
- Planer, horse-power required to run, 1302  
 tools, standard, 1271-1274  
 work, 1270-1274
- Planers, feeds and speeds of, 1270  
 power requirements of, 1302
- Planing, time required for, 1271  
 work that should be planed, 1270
- Planished and Russia iron, 473
- Plank, wooden, maximum spans for, 1392
- Plate-girder, strength of, 353  
 -girders, allowed stresses in, 289
- Plates** (*see also* Sheets)  
 acid pickled, heat transmission through, 591  
 areas of, in square feet, table, 128, 129  
 brass, weight of, tables, 228, 229  
 Carnegie trough, properties of, table, 308  
 circular, strength of, 336  
 copper, strength of, 356  
 copper, weight of, table, 229  
 corrugated steel, properties of, table, 310  
 flat, cast-iron, strength of, 336  
 flat, for steam-boilers, rules for, 916  
 flat, unstayed, strength of, 337  
 for stand-pipes, 349  
 iron and steel, approximating weight of, 486  
 iron, weight of, table, 187, 188  
 of different materials, table for calculating weights of, 181  
 perforated, strength of, 425  
 punched, loss of strength in, 424  
 stayed, strength of, 338  
 steel boiler, specifications for, 507  
 steel, for cars, specifications for, 507  
 steel, specifications for, 507  
 steel, tests of, 353, 355  
 transmission of heat through, 587  
 transmission of heat through, from air to water, 592



- Plates, transmission of heat through, from steam to air, 595
- Plating for bulkheads, table, 339  
steel, stresses in, due to water pressure, 338  
for tanks, table, 338
- Platinite, 499, 567
- Platinum, properties of, 179  
pyrometer, 553  
wire, 248
- Plenum system of heating, 708
- Plow-steel wire, 250  
-steel wire-rope, 257, 259
- Plugs, fusible, in steam boilers, 918
- Plunger packing, hydraulic, friction of, 1239
- Pneumatic conveying, 1201  
hoisting, 1187  
postal transmission, 1201
- Polarity of electro-magnets, 1432
- Poles, tubular, for electric lines, 206
- Polishing and buffing, 1310  
wheels, speed of, 1310
- Polyedron, 63
- Polygon, area of, 55  
construction of, 42-45  
of forces, 513
- Polygons, impedance, 1442  
table of, 45, 55
- Polyphase circuits, 1445
- Popp system of compressed-air, 639-641
- Population of the United States, 11
- Port opening in steam-engines, 1057
- Portland cement, strength of, 358
- Postal transmission, pneumatic, 1201
- Potential energy, 528
- Pound, British avoirdupois, 26  
-calorie, definition of, 560
- Pounds per square inch, equivalents of, 27
- Power**, animal, 532  
and work, definition of, 528  
electrical, cost of, 1012  
factor of alternating currents, 1440  
hydraulic, in London, 814  
measures of, 27  
of a waterfall, 765  
of electric circuits, 1408  
of ocean waves, 786  
required for machine tools, 1292-1302  
required to drive machines in groups, 1305  
unit of, 528
- Powers of numbers, algebraic, 33  
of numbers, tables, 7, 8, 93-110
- Power-plant economics, 1011
- Pratt truss, stresses in, 544
- Preservative coatings, 471-474
- Press fits, pressure required for, 1324-1326  
forging, high-speed, steam hydraulic, 815  
hydraulic forging, 814  
hydraulic, thickness of cylinders for, 340
- Presses, hydraulic, in iron works, 813  
punches and shears, fly-wheels for, 1323  
punches, etc., 1321
- Pressed fuel, 831
- Pressure, collapsing of flues, 342  
collapsing of hollow cylinders, 341
- Pressures of fluids, conversion table for, 607
- Priming, or foaming, of steam boilers, 721, 930
- Prism, 62
- Prismoid, 63  
rectangular, 62
- Prismoidal formula, 63
- Problems, geometrical, 37-53  
in circles, 39-44  
in lines and angles, 37-39  
in polygons, 42-45  
in triangles, 41
- Process, the Thermit, 400
- Producer-gas, 848-855 (*see Gas*)
- Producers, gas (*see Gas-producers*)  
gas, use of steam in, 854
- Profit and loss, 12
- Progression, arithmetical and geometrical, 10, 11
- Projectile, parabola path of, 525
- Prony brake, 1333
- Propeller, screw (*see Screw-propeller*) 1377  
shafts, strength of, 354
- Proportion, 6  
compound, 7
- Protective coatings for pipes, 206
- Pulleys**, 1135-1138  
arms of, 1050  
cone, 1136  
cone, on machine tools, 1307  
convexity of, 1136  
differential, 539  
for rope-driving, 1217  
or blocks, 538  
proportions of, 1111  
speed of, 1148, 1162
- Pulsometer, 806  
tests of, 807
- Pumps**, air-, for condensers, 1071, 1073  
air-lift, 808  
and pumping-engines, 788-812  
boiler-feed, 792  
boiler-feed, efficiency of, 937  
centrifugal, 796-802  
centrifugal, combination single stage and two stage, 798  
centrifugal, design of, 797  
centrifugal, multi-stage, 797

- Pumps, centrifugal, relation of height of lift to velocity, 797  
 centrifugal, tests of, 798, 800, 802  
 circulating, for condensers, 1075  
 depth of suction of, 788  
 direct-acting, efficiency of, 790  
 direct-acting, proportion of steam cylinder, 790  
 electric motors for, 1463  
 feed, for marine engines, 1076  
 gas-engine, 808  
 high-duty, 793  
 horse-power of, 788  
 jet, 807  
 leakage, test of, 803  
 lift, water raised by, 790  
 mine, operated by compressed air, 652  
 piston speed of, 791, 792  
 rotary, 801  
 rotary, tests of, 802  
 speed of water in passages of, 790  
 steam, sizes of, tables, 789, 791  
 suction of, with hot water, 788  
 theoretical capacity of, 788  
 underwriters', sizes of, 792  
 vacuum, 806  
 valves of, 792, 793  
 Pump-inspection table, 751  
 Pumping by compressed air, 645, 808 (*see also* Air-lift)  
 by gas-engines, cost of, 795  
 by steam pumps, cost of fuel for, 795  
 cost of electric current for, 794  
**Pumping-engine**, 72,000,000 gal., 793  
 screw, 794  
 the d'Auria, 793  
 Pumping-engines, duty trials of, 802-806  
 economy of, 794  
 high-duty records, 806  
 table of data for duty trials of, 803-805  
 use of nozzles to measure discharge of, 759  
 Punches and dies, clearance of, 1321  
 spiral, 1322  
 Punched plates, strength of, 425  
 Punching and drilling of steel, 483, 485  
 Purification of water, 723-726  
 Pyramid, 62  
 frustum of, 62  
**Pyrometer**, air, Wiborgh's, 555  
 copper-ball, 553  
 fire-clay, Seger's, 555  
 Hobson's hot-blast, 555  
 Le Chatelier's, 554  
 principles of, 549  
 thermo-electric, 553  
 Uehling-Steinbart, 557  
 Pyrometers, graduation of, 554  
 Pyrometric telescope, 556  
 Pyrometry, 549
- Q**UARTER-TWIST belt, 1147  
 Queen-post truss, inverted, stresses in, 544  
 truss, stresses in, 543  
 Quenching test for soft steel, 507
- R**ACK, gearing, 1165  
 Radian, definition of, 523  
 Radiating power of substances, 578  
 surface, computation of, for hot-water heating, 704  
 surface, computation of, for steam heating, 698  
 surface, proportioning pipes for, 700  
 Radiation, black body, 579  
 of heat, 578  
 of various substances, 578, 595  
 Stefan and Boltzman's law, 579  
 table of factors for Dulong's laws of, 596  
 Radiators, experiments with, 697, 708  
 indirect, 698  
 overhead steam-pipe, 702  
 steam and hot-water, 697  
 steam, removal of air from, 702  
 transmission of heat in, 697  
 Radius of gyration, 293, 518  
 of gyration, graphical method for finding, 294  
 of gyration of structural shapes, 293, 294  
 of oscillation, 518  
 Rails, steel, electric resistance of, 1416  
 steel, specifications for, 508  
 steel, strength of, 353  
 Railroad axles, effect of cold on, 465  
 steam, electrifications of, table, 1418  
 track, material required for one mile of, 244, 245  
 trains, resistance of, 1108-1111  
 trains, speed of, 1118  
 Railway curve, degree of a, 54  
 street, compressed-air, 652  
 track bolts and nuts, 244, 245  
 Railways, electric (*see* Electric railways), 1414  
 narrow-gage, 1127  
 Ram, hydraulic, 810  
 Rankine cycle efficiency for different conditions, 1091  
 cycle, efficiency of, 996, 1089  
 Rankine's formula for columns, 284  
 Ratio, 6  
 Raw-hide pinions, 1177  
 Reactance of alternating currents, 1441  
 in transformers, 1452  
 Reaction of a jet, 1385  
 Reamers, taper, 1318  
 Réaumur thermometer-scale, 549

- Recalcence of steel, 480  
 Receiver-space in engines, 980  
 Receivers on steam pipe lines, 884  
 Reciprocals of numbers, tables of, 87-92  
   use of, 92  
 Recorder, carbon dioxide, or CO<sub>2</sub>, 890  
   continuous, of water or steam consumption, 970  
 Rectangle, definition of, 54  
   value of diagonal of, 54  
 Rectangular prismoid, 62  
 Rectifier, in absorption refrigerating machine, 1346  
   mercury arc, 1456  
 Reduction, ascending and descending, 5  
 Reese's fusing disk, 1309  
 Reflecting power of substances, 578  
**Refrigerating** (*see also* Ice-making), 1336-1367  
   air-machines, 1343  
   direct-expansion method, 1365  
**Refrigerating - machines**, actual and theoretical capacity, 1355  
   ammonia absorption, 1346, 1364  
   ammonia compression, 1345, 1356  
   condensers for, 1353  
   cylinder-heating, 1349  
   diagrams of, 1348  
   dry, wet, and flooded systems, 1345  
   ether-machines, 1343  
   heat-balance, 1359  
   ice-melting effect, 1343  
   liquids for, pressure and boiling points of, 1337  
   mean effective pressure and horse-power, 1350  
   operations of, 1336  
   performance of, 1364  
   pipe-coils for, 1354  
   pounds of ammonia per minute, 1350  
   properties of brine, 1343  
   properties of vapor, 1337  
   quantity of ammonia required for, 1351  
   rated capacity of, 1353  
   relative efficiency of, 1348  
   relative performance of ammonia-compression and absorption machines, 1347  
   sizes and capacities, 1352  
   speed of, 1353  
   sulphur-dioxide, 1345  
   temperature range, 1360  
   test reports of, 1358  
   tests of, 1355  
   using water vapor, 1345  
   volumetric efficiency, 1349  
   Voorhees multiple-effect, 1351  
**Refrigerating plants**, cooling-tower practice in, 1354  
   systems, efficiency of, 1349  
 Refrigeration, 1336-1367  
   a reversed heat cycle, 600  
   cooling effect, compressor volume, and power required, 1341  
   cubic feet space per ton of, 1368  
   means of applying the cold, 1365  
 Regenerator, heat, 1014  
 Regnault's experiments on steam, 870  
 Reinforced concrete, working stresses of, 1387  
 Reluctance, magnetic, 1398, 1430  
 Reluctivity, magnetic, 1400  
 Reservoirs, evaporation of water in, 569  
 Resilience, elastic, 274  
   of materials, 274  
**Resistance**, elastic to torsion, 334  
**Resistance, electrical** (*see also* Electrical resistance), 1400  
   effect of annealing on, 1402  
   effect of temperature on, 1402  
   in circuits, 1406  
   internal, 1408  
   of copper wire, 1402, 1404  
   of copper wire, rule for, 1406  
   of steel, 477  
   of steel rails, 1416  
   standard of, 1402  
**Resistance**, elevation of ultimate, 275  
   frictional, of surfaces moved in water, 756  
   moment of, and section modulus, 294, 295  
   of metals to repeated shocks, 276  
   of ships, 1369  
   of trains, 1108-1111  
   tractive, of an electric car, 1415  
   work of, of a material, 274  
 Resistivity, definition of, 1403  
   of copper, 1403, 1406  
 Resolution of forces, 513  
 Retarded motion, 521  
 Reversing-gear for steam-engines, dimensions of, 1039  
 Rhomboid, definition and area of, 54  
 Rhombus, definition and area of, 54  
**Rivet-iron and steel**, shearing resistance of, 430  
   spacing for structural work, 321, 322  
**Rivets**, bearing pressure on, 426  
   center distances, of staggered, 322  
   cone-head, 239  
   diameters of, for riveted joints, table, 429  
   in steam-boilers, rules for, 913, 914  
   length required for various grips, 241  
   minimum spacing and clearance, 322



- Rivets, oval head, sizes and weights, 238  
pitch of, 426  
pressure required to drive, 435  
round head, weight of, 243  
shearing value, area of rivets, and bearing value, 240  
steel, chemical and physical tests of, 435  
steel, specifications for, 505  
tinnern', table, 239
- Riveted iron pipe, dimensions of, table, 220
- Riveted joints**, 355, 424-435  
British rules for, 433  
drilled, *vs.* punched holes, 424  
efficiencies of, 428-434, 914  
notes on, 425  
of maximum efficiency, 431  
proportions of, 427-434  
single riveted lap, 427  
table of proportions, 434  
tests of double-riveted lap and butt, 429  
tests of, table, 359  
triple and quadruple, 431  
triple, working pressures on steam-boilers with, 917
- Riveted pipe, flow of water in, 734-736  
pipe, weight of sheet steel for, 221
- Riveting, cold, pressure required for, 435  
efficiency of different methods, 425  
hand and hydraulic, strength of, 425  
machines, hydraulic, 814  
of structural steel, 484  
pressure required for, 435
- Roads, resistance of carriages on, 534
- Rock-drills, air required for, 645  
requirements of air-driven, 645
- Rods of different materials, tables for calculating weights of, 181
- Rollers and balls, steel, carrying capacity of, 340  
bearings, 1233  
chain and sprocket drives, 1153
- Rolling of steel, effect of finishing temperature, 478
- Roof construction, 191-195  
paints, 192  
-truss, stresses in, 547
- Roofs, snow and wind, [loads on, 191  
strength of, 1389
- Roofing materials and roof construction, 191-195  
materials, weight of various, 191
- Rope-driving**, 1214-1218  
English practice, 1218  
horse-power of, 1215  
pulleys for, 1217  
sag of rope, 1216  
tension of rope, 1214
- Rope-driving, weight of rope, 1218
- Ropes and cables**, 410-415  
cotton and hemp, strength of, 357  
cotton, for transmission, 1218  
for hoisting or transmission, 410-415  
hemp, iron and steel, table of strength and weight of, 410  
hoisting (*see* Hoisting-rope)  
locked-wire, 262  
manila, 411  
manila, data of, 1214-1218  
manila, hoisting and transmission, life of, 415  
manila, weight and strength of, 410-415  
splicing of, 412  
table of strength of iron, steel and hemp, 410  
taper, of uniform strength, 1208  
technical terms relating to, 411  
wire, "Lang Lay," 254  
wire (*see also* Wire-rope)  
wire, track cable for aerial tramways, 260
- Rotary blowers, 677  
steam engines, 1082
- Rotation, accelerated, work of, 529
- Rubber belting, 1152  
goods, analysis of, 378  
vulcanized, tests of, 378
- Rule of three, 6, 7
- Running fits, 1325
- Rupture, modulus, of, 297
- Russia and planished iron, 473
- S**AFETY, factor of, 374-377  
valves for locomotives, 935  
valves for steam-boilers, 932-935  
valves, spring-loaded, 933
- Sag of wires between poles, 1432
- Salt, solubility of, 571  
weight of, 180
- Salt-brine manufacture, evaporation in, 570  
properties of, 570, 571, 1343  
solution, specific heat of, 564
- Sampling coal for analysis, 825
- Sand, cubic feet per ton, 181  
molding, 1256
- Sand-blast, 1309
- Sand-lime brick, tests of, 371
- Sandstone, strength of, 371
- Saturation point of vapors, 604
- Sawdust as fuel, 838
- Sawing metal, 1309  
-machines for metals, 1291  
metals, speeds and feeds for, 1291
- Scale, boiler, 721, 927-932  
boiler, analyses of, 722  
effect of, on boiler efficiency, 928  
removal of, from steam-boilers, 930
- Scales, thermometer, comparison of, 550, 551

- Scantling, table of contents of, 21  
 Schiele pivot bearing, 1233  
 Schiele's anti-friction curve, 50  
 Scleroscope, for testing hardness, 365
- Screw, 61**  
 -bolts, efficiency of, 538  
 conveyors, 1198  
 differential, 540  
 efficiency of a, 538  
 (element of machine), 537  
 heads, machine, dimensions of, 237  
 -propeller, 1377  
 -propeller, coefficients of, 1378  
 -propeller, efficiency of, 1379  
 -propeller, slip of, 1379
- Screws and nuts for automobiles, table, 233**  
 cap, table of standard, 238  
 lag, holding power of, 347  
 lag, table of, 241  
 machine, A. S. M. E. standard, 234  
 machine, dimensions of, 234-238  
 set, table of standard, 238  
 wood, 236  
 wood, holding power of, 346
- Screw-threads, 231-238**  
 Acme, 234  
 A. S. M. E. standard, table, 237  
 British Association standard, 232  
 English or Whitworth standard, table, 232  
 International (metric) standard, 232  
 limit gages for, 232  
 metric, cutting of, 1261  
 standard sizes for bolts and taps, 235, 236  
 U. S. or Sellers standard, table of, 231
- Scrubbers for gas producers, 849  
 Sea-water, freezing-point of, 719  
 Secant of an angle, 66  
 of an arc, 67  
 Secants of angles, table of, 170-172
- Section modulus of structural shapes, 294, 295  
 Sector of circle, 60  
 Sediment in steam-boilers, 928  
 Seger pyrometer cones, 555  
 Segment of circle, 60  
 Segments, circular, areas of, 121, 122
- Segregation in steel ingots, 487  
 Self-inductance of lines and circuits, 1445  
 "Semi-steel," 453
- Separators, steam 941  
 steam, efficiency of, 941
- Set-screws, dimensions of, 238  
 holding power of, 1332  
 standard table of, 238
- Sewers, grade of, 757  
 Shackles, strength of, 1184
- Shaft bearings, 1034**  
 bearings, large, tests of, 1230  
 couplings, flange, 1133  
 fit, allowances for electrical machinery, 1326  
 -governors, 1066  
 speeds in geometrical progression, 1138
- Shafts and bearings of engines, 1042-1044**  
 bearings for, 1034  
 bending resistance of, 1032  
 dimensions of, 1030-1033  
 equivalent twisting moment of, 1032  
 fly-wheel, 1033  
 hollow, 1133  
 hollow, torsional strength of, 334  
 steam-engine, 1030-1038  
 steel propeller, strength of, 354  
 twisting resistance of, 1030
- Shafting, 1130-1134**  
 collars for, 1133  
 deflection of, 1131  
 formulæ for, 1130  
 horse-power transmitted by, 1130  
 keys for, 1328  
 laying out, 1134  
 power required to drive, 1305  
 torsion tests of, 361
- Shaku-do, Japanese alloy, 393  
 Shapers, motors required to run, 1296
- Shapes of test specimens, 280  
 structural steel, dimensions and weights, 302-305
- Shear and compression combined, 335  
 and tension combined, 335  
 poles, stresses in, 542
- Shearing, effect of on structural steel, 483  
 resistance of rivets, 430  
 strength of iron and steel, 362  
 strength of rivets, 240  
 strength of woods, table, 367  
 strength, relation to tensile strength, 362
- Sheaves, diameter of, for wire-rope, 1211  
 for wire-rope transmission, 1208, 1211  
 size of for manila rope, 414
- Sheet aluminum, weight of, 230**  
 brass, weight of, table, 228  
 copper, weight of, 229  
 iron and steel, weight of, 183  
 metal gage, 28, 29, 31, 32  
 metal, weight of, by decimal gage, 32  
 metals, strength of various, 356
- Sheets (*see* Plates)  
 Shelby cold-drawn tubing, 223  
 Shells for steam-boilers, material for, 908  
 spherical, strength of, 339

- Sherardizing, 474  
 Shibu-ichi, Japanese alloy, 393  
 Shingles, weights and areas of, 196  
**Ship** "Lusitania," performance of, 1376, 1381  
 Ships, Atlantic steam, performance of, 1376, 1383  
   coefficient of fineness of, 1369  
   coefficient of performance, 1370  
   coefficient of water lines, 1369  
   displacement of, 1369, 1374  
   horse-power for given speeds, 1373  
   horse-power of, from wetted surface, 1372  
   horse-power of internal combustion engines for, 1374  
   horse-power required for, 1373-1375  
   jet propulsion of, 1384  
   relation of horse-power to speed, 1373, 1376  
   resistance of, 1369  
   resistance of, per horse-power, 1373  
   resistance of, Rankine's formula, 1370  
   rules for measuring, 1368  
   rules for tonnage, 1369  
   small sizes, engine power required for, 1374  
   wetted surface of, 1371  
   wetted surface, empirical equations for, 1371  
   with reciprocating engine, and turbine combined, 1383  
 Shipbuilding, steel for, 507  
 Shipping measure, 19, 1368  
 Shocks, resistance of metals to repeated, 276  
   stresses produced by, 276  
 Short circuits, electric, 1411  
 Shrinkage fits (*see* Fits, 1324)  
   of alloys, 409  
   of castings, 1254  
   of cast-iron, 438, 447  
   of malleable iron castings, 455  
   strains relieved by uniform cooling, 448  
 Sign of differential coefficients, 78  
   of trigonometrical functions, 67  
 Signs, arithmetical, 1  
 Silicon-aluminum-iron alloys, 398  
   -bronze, 395  
   -bronze wire, 248, 395  
   distribution of in pig iron, 448  
   excessive, making cast-iron hard, 1254  
   influence of, on cast-iron, 438, 447  
   influence of, on steel, 476  
 Silundum, 1425  
 Silver, melting temperature, 554, 559  
   properties of, 179  
 Simpson's rule for areas, 56  
 Sine of an angle, 66  
 Sines of angles, table, 170-172  
 Single-phase circuits, 1445  
 Sinking fund, 17  
 Siphon, 754  
 Sirocco fans, 653, 664-666  
 Skin effect in alternating currents, 1442  
 Skylight glass, sizes and weights, 196  
 Slag bricks and slag blocks, 268  
   in cupolas, 1248  
   in wrought iron, 460  
 Slate roofing, sizes, areas, and weights, 195  
 Slide rule, 82  
**Slide-valve**, cut-off for various laps and travels, table, 1060, 1061  
   definitions, 1052  
   diagrams, 1053-1055  
   effect of lap and lead, 1052-1057  
   lead, 1057  
   port opening, 1057  
   ratio of lap to travel, 1058  
   relative motion of cross-head and crank, 1060  
   steam-engine, 1052-1062  
 Slope, table of, and fall in feet per mile, 729  
 Slotters, power required to run, 1295  
 Smoke-prevention, 920-922  
 Smoke-stacks, locomotive, 1115  
   sheet-iron, 958  
 Snow load on roofs, 191  
   weight of, 720  
 Soapstone lubricant, 1246  
   strength of, 371  
 Soda mixture for machine tools, 1246  
 Softeners in foundry practice, 1253  
 Softening of water, 724  
 Soils, bearing power of, 1385  
   resistance of, to erosion, 755  
 Solar engines, 1015  
 Solder, brazing, composition of, 390  
   for aluminum, 382, 383  
 Solders, composition of various, 383, 409  
 Soldering aluminum-bronze, 397  
 Solid bodies, mensuration of, 61-66  
   measure, 18  
   of revolution, 64  
 Solubility of common salt, 571  
   of sulphate of lime, 571  
 Soot, effect of on boiler tubes, 931  
 Sorbite, 480  
 Sources of energy, 531  
**Specific gravity**, 173-175  
   and Baumé's hydrometer compared, table, 175  
   and strength of cast iron, 452  
   of brine, 571  
   of cast-iron, 452  
   of copper-tin alloys, 384



- Specific gravity of copper-zinc alloys, 388  
of gases, 176  
of ice, 720  
of liquids, table, 175  
of metals, table, 174  
of steel, 486  
of stones, brick, etc., 177
- Specific heat**, 562-565, 720  
determination of, 562  
of air, 562, 614  
of gases, 563, 564  
of ice, 720  
of iron and steel, 562, 563  
of liquids, 563  
of superheated steam 869  
of metals, 562, 563  
of solids, 562, 563  
of saturated steam, 867  
of water, 564, 720  
of woods, 563
- Specifications for boiler-plate**, 507  
castings, 441  
cast iron, 441  
chains, 264  
elliptical steel springs, 423  
foundry pig iron, 443  
fuel oil, 843  
galvanized wire, 250  
helical steel springs, 423  
hose, 379  
malleable iron, 457  
metal for cast-iron pipe, 441  
oils, 1242  
petroleum lubricants, 1242  
phosphor-bronze, 395  
purchase of coal, 830  
spring steel, 507  
steel axles, 507, 509  
steel billets, 507  
steel castings, 489, 510  
steel crank-pins, 507  
steel for automobiles, 510  
steel forgings, 506  
steel for ships, 507  
steel rails, 508  
steel rivets, 505  
steel splice-bars, 509  
steel tires, 509  
structural steel, 504  
tin and terne-plate, 194  
wrought iron, 461, 462
- Speed of cutting, effect of feed and depth of cut on, 1264  
of cutting tools, 1258  
vessels, 1373
- Speeds in geometrical progression, 1307
- Spelter, (*see* Zinc)
- Sphere, measures of, 62
- Spheres of different materials, table for calculating weight of, 181  
table of volumes and surfaces, 126, 127
- Spherical polygon, area of, 63  
segment, volume of, 64  
shells and domed boiler heads, 339
- Spherical polygon shells, strength of, 339  
shells, thickness of, to resist a given pressure, 339  
triangle, area of, 63  
zone, area and volume of, 64
- Spheroid, 64
- Spikes, holding power of, 346  
railroad and boat, 245, 248  
wrought, 245
- Spindle, surface and volume of, 64, 65
- Spiral, 51, 61  
conical, 61  
construction of, 51  
gears, 1168  
plane, 61  
-riveted pipe-fittings, table, 220  
-riveted pipe, table of, 220
- Splice-bars, steel, specifications for, 509
- Splices, railroad track, tables, 245
- Splicing of ropes, 412  
of wire rope, 263
- Spontaneous combustion of coal, 832
- Springs**, 417-424  
elliptical, sizes of, 423  
elliptical, specifications for, 423  
for engine-governors, 1066-1068  
helical, 418-422  
helical, formulæ for deflection and strength, 418  
helical, specification for, 423  
helical, steel, tables of capacity and deflection, 418-422  
laminated steel, 417  
phosphor-bronze, 424  
semi-elliptical, 417  
steel, chromium-vanadium, 424  
steel, strength of, 355  
to resist torsion, 423
- Sprocket wheels, 1154, 1156
- Spruce, strength of, 367
- Square**, definition of, 54  
measure, 18  
root, 8  
roots of fifth powers, 110  
roots, tables of, 93-108  
side of, equivalent to circle of same area, 125  
value of diagonal of, 54
- Squares of decimals, table, 108  
of numbers, table, 93-108
- Squirrel-cage motor, 1463
- Stability, 515  
of chimneys, 954  
of dam, 515
- Stand-pipes**, 349-351  
at Yonkers, N. Y., 350  
failures of, 350  
guy-ropes for, 349  
heights of, for various diameters and plates, table, 351  
thickness of plates of, table, 351  
thickness of side plates, 349  
wind-strain on, 349

- Star connection, transformers, 1452
- Statical moment, 515
- Stay-bolt iron, 462
- Stay-bolts in steam-boilers, 916
- Stays, steam-boiler, loads on, 916
- steam-boiler, material for, 908
- Stayed surfaces, strength of, 338
- Steam**, 867-885
- boilers (*see Steam-boilers below*)
- calorimeters, 942-944
- consumption, continuous recorder for, 970
- consumption in engines, Willan's law, 991
- determining moisture in, 942-945
- domes on boilers, 918
- drums, 913
- dry, definition, 867
- dry, identification of, 944
- energy of, expanded to various pressures, 963
- engines (*see Steam-engines, below*)
- entropy of, tables, 871-874
- expanding, available energy of, 870
- expansion of, 959
- fire-engines, capacity and economy of, 993, 994
- flow of, 876-882 (*see Flow of steam*)
- gaseous, 870
- generation of, from waste heat of coke-ovens, 834
- heat required to generate 1 pound of, 867
- heating, 694-703
- heating, diameter of supply mains, 699, 701
- heating, indirect, 698
- heating of greenhouses, 702
- heating, pipes for, 699-701
- heating, vacuum systems of, 702
- jackets on engines, 1004
- jet blower, 679
- jet exhauster, 679
- jet ventilator, 679
- latent heat of, 867
- loop, 883
- loss of pressure in pipes, 880
- maximum efficiency of, in Carnot cycle, 881
- mean pressure of expanded, 960
- metal (bronze alloy), 390, 392
- moisture in, escaping from boilers, 945
- pipe coverings, tests of, 584-587
- pipes (*see Steam-Pipes below*)
- ports, area of, 880
- power, cost of, 1009-1011
- receivers on pipelines, 884
- Regnault's experiments on, 870
- sampling for moisture, 942
- saturated, definition, 867
- Steam, saturated, density, volume and latent heat of, 869, 871
- saturated, properties of at high temperatures, 868
- saturated, properties of, table, 869, 871-874
- saturated, specific heat of, 867
- saturated, temperature and pressure of, 868
- saturated, total heat of, 867
- separators, 941
- separators, efficiency of, 941
- ships, Atlantic, performances of, 1376, 1383
- superheated (*see also Superheated steam*)
- superheated, definition, 867
- superheated, economy of steam-engines with, 998
- superheated, pipes and valves for, 882
- superheated, properties of, 870, 874, 875
- superheated, specific heat of, 869
- superheated, volume of, 869
- temperature of, 867
- vessels (*see Ships*)
- weight of, per cubic foot, table, 871
- wet, definition, 867
- Steam-boilers**, 885-944 (*see also Boilers*)
- air-leakage in, 891
- braces in 916
- bumped heads, rules for, 914
- combustion space in furnaces of, 889
- compounds, 929
- conditions to secure fuel economy in, 890, 893
- construction of, 908-918
- corrosion of, 467, 927-932
- curves of performance of, 894, 895
- dangerous, 932
- domes on, 918
- down-draught furnace for, 919
- effect of rate of driving, 893
- effect of soot on, 931
- Steam-boiler efficiency**, at different rates of driving, 898
- computation of, 687, 891
- effect of excess air supply, 896
- effect of imperfect combustion, 896
- effect of quality of coal, 895
- maximum, 898
- obtained in practice, 897
- relation of, to rate of driving, air-supply, etc., 893
- straight line formula for, 896
- Steam-boilers**, evaporative tests of, 898, 899-908
- excess air supply to, 896
- explosive energy of, 932
- factors of evaporation, 908-912
- factors of safety of, 918
- feed-pumps for, efficiency of, 937

- Steam-boilers, feed-water heaters for, 938-940 (*see* Feed-water heaters)  
 feed-water, saving due to heating of, 938  
 flat plates in, rules for, 916  
 flues and gas passages, proportions of, 889  
 foaming or priming of, 721, 930  
 for blast-furnaces, 899  
 forced combustion in, 923  
 fuel economizers, 924  
 furnace formulæ, 917  
 furnaces, height of, 889  
 fusible plugs in, 918  
 grate-surface, 887, 888  
 grate-surface, relation to heating surface, 887  
 gravity feeders, 938  
 heating-surface in, 887, 888  
 heating-surface, relation of, to grate-surface, 887  
 heat losses in, 892  
 height of chimney for, 948, 950  
 high rates of evaporation, 898  
 horse-power of, 885  
 hydrostatic test of, 918  
 imperfect combustion in, 896  
 incrustation of, 927-932  
 injectors on, 936-938 (*see* Injectors)  
 man-hole openings in, 914  
 marine, corrosion of, 930  
 measure of duty of, 886  
 mechanical stokers for, 918  
 moisture in steam escaping from, 944  
 performance of, 889  
 plates, ductility of, 913  
 plates, tensile strength of, 908, 913  
 pressure allowable in, 917, 918  
 proportions of, 887-889  
 proportions of grate- and heating-surface for given horse-power, 887, 888  
 proportions of grate-spacing, 889  
 quench-bend tests of steel for, 913  
 riveting rules for, 914  
 safety-valves, 932-935  
 safety-valves, discharge of steam through, 934  
 safety-valves, formulæ for, 932  
 safety-valves, spring-loaded, 933  
 safe working-pressure, 918  
 scale compounds, 929  
 scale in, 927-932  
 sediment in, 928  
 shells, material for, 908  
 smoke prevention, 920-923  
 stay-bolts in, 916  
 stays, loads on, 916  
 stays, material for, 908  
 steel for, 913  
 strain caused by cold feed-water, 939
- Steam-boilers, strength of, 908-918  
 strength of circumferential seams, 913  
 strength of rivets, 914  
 tests, heat-balance in, 907  
 tests, rules for, 899-908  
 thickness of plates, 913  
 tube holes, 916  
 tube-plates, rules for, 914  
 tube spacing in, 916  
 tubes, holding power of, 916  
 tubes, iron and steel, 916, 917  
 tubes, material for, 913  
 tubes, size of, 917  
 use of kerosene in, 929  
 use of zinc in, 931  
 using waste gases, 898, 899  
 working pressures on with triple riveted joints, 917
- Steam-engines, 959-1095**  
 advantages of compounding, 976  
 advantages of high initial and low back pressure, 996  
 and turbine, best economy of, in 1904, 1005  
 bearings, size of, 1034  
 bed-plates, dimensions of, 1044  
 clearance in, 966
- Steam-engines, compound, 976-983**  
 best cylinder ratios, 982  
 calculation of cylinders of, 982  
 combined indicator diagram, 979  
 cylinder proportions, 980  
 economy of, 997  
 estimating horse-power of, 971  
 formulæ for expansion and work in, 981  
 high-speed, performance of, 989, 990  
 high-speed, sizes of, 989, 990  
 non-condensing, efficiency of, 1000  
 receiver, ideal diagram, 977  
 receiver space in, 980  
 receiver type, 977  
 steam-jacketed, performances of, 989  
 steam-jacketed, test of, 1005  
 Sulzer, water-consumption of, 998  
 test of with and without jackets, 1005  
 two-cylinder *vs.* three-cylinder, 997  
 velocity of steam in passages of, 986  
 water consumption of, 988  
 Woolf, ideal diagram, 977
- Steam-engines, compression, effect of, 965  
 condensers, 1069-1079 (*see* Condensers)  
 connecting-rod ends, 1026



- Steam-engines, connecting-rods, dimensions of, 1025, 1040, 1041  
 cost of power from, 1009-1011  
 counterbalancing of, 1008  
 crank-angles, table, 1058  
 crank-pins, dimensions of, 1027, 1040, 1041  
 crank-pins, pressure on, 1028  
 crank-pins, strength of, 1027  
 cranks, dimensions of, 1027  
 crank-shafts, dimensions of, 1030-1038, 1040, 1041  
 crank-shafts, formulæ for torsion and flexure, 1038  
 crank-shafts for triple-expansion, 1038  
 crank-shafts, three-throw, 1038  
 cross-head and crank, relative motion of, 1060  
 cross-head, dimensions of, 1040, 1041  
 cross-head pin, dimensions of, 1029, 1040, 1041  
 cut-off, most economical point of, 1009  
 cylinder condensation, experiments on, 967  
 cylinder condensation, loss by, 966  
 cylinder, finding size of, 970  
 cylinders, dimensions of, 1021, 1022, 1039, 1041  
 cylinders, ratios of, 980, 982, 986  
 cylinder-head bolts, size of, 1022, 1039, 1041  
 cylinder-heads, dimensions of, 1022, 1039  
 design, current practice, 1039-1041  
 dimensions of parts of, 1007, 1021-1042  
 eccentric-rods, dimensions of, 1039  
 eccentrics, dimensions of, 1039  
 economic performance of, 987-1007
- Steam-engines, economy at various loads and speeds, 992, 993**  
 effect on of wet steam, 1001  
 of in central stations, 992  
 of simple and compound compared, 997  
 tests of high speed, 994  
 under variable loads, 992  
 with superheated steam, 998
- Steam-engines, effect of leakage on indicator diagram, 976  
 effect on, of moisture in steam, 1001  
 efficiency in thermal units per minute, 964  
 estimating I.H.P. of single cylinder and compound, 970  
 exhaust steam used for heating, 1009  
 expansions in, table, 965  
 fly-wheels (*see* Fly-wheels), 1040, 1041, 1044-1052
- Steam-engines, foundations embedded in air, 1009  
 frames, dimensions of, 1044  
 friction of, 1238  
 governors, fly-ball, 1066  
 governors, fly-wheel, 1066  
 governors, shaft, 1066  
 governors, springs for, 1066-1068  
 guides, sizes of, 1024  
 highest economy of, 1003  
 high piston speed in, 995  
 high-speed, British, 995  
 high-speed Corliss, 995  
 high-speed, economy of, 994  
 high-speed, performance of, 988, 989, 992  
 high-speed, sizes of, 988-992  
 high-speed throttling, 996  
 horse-power constants, 971-974  
 indicated horse-power, 970-976  
 indicator diagrams, (*see* Indicator), 968-976  
 indicator rigs, 969  
 indicators, errors of, 969  
 influence of vacuum and superheat on economy, 1001  
 Lentz compound, 997  
 limitations of speed of, 995  
 link motions, 1062-1065  
 mean and terminal pressures, 960  
 mean effective pressure, calculations of, 961  
 measures of duty of, 963  
 non-condensing, 998-990  
 oil required for, 1245  
 pipes for, 879, 1039, 1040  
 piston-rings, size of, 1023  
 piston-rod guides, size of, 1024  
 piston-rods, fit of, 1024  
 piston-rods, size of, 1024, 1040, 1041  
 pistons, clearance of, 1021  
 pistons, dimensions of, 1022, 1040, 1041  
 piston-valves, 1061  
 prevention of vibration in, 1008  
 proportions, current practice, 1039-1041  
 proportions of, 1021-1042  
 quadruple-expansion, 986  
 quadruple, performance of, 1003  
 Rankine cycle efficiencies, 996  
 ratio of cylinder capacity in compound marine, 980  
 ratio of expansion in, 962  
 reciprocating parts, weight of, 1040, 1041  
 relative cost of, 1011  
 reversing gear, dimensions of, 1039  
 rolling-mill, sizes of, 1008  
 rotary, 1082  
 rules for tests of, 1015  
 setting the valves of, 1061  
 shafts and bearings (*see* Shafts), 1030-1033, 1040, 1041  
 single-cylinder, economy of, 987

- Steam-engines, single-cylinder, high-speed, sizes and performance of, 989  
 single-cylinder, water consumption of, 987-1007  
 slide valves (*see* Slide Valves), 1053-1055  
 small, coal consumption of, 993  
 small, water consumption of, 992  
 Sulzer compound and triple-expansion, 998  
 superheated steam in, 998  
 steam consumption of different types, 999  
 steam-jackets, influence of, 1004  
 steam-turbines and gas-engines compared, 1013  
 Stumpf uniflow, 997  
 test of with superheated steam, 998  
 three-cylinder, 1038  
 to change speed of, 1066  
 to put on center, 1061
- Steam-engines, triple-expansion,** 983-986  
 crank-shafts for, 1038  
 cylinder proportions, 983-985  
 cylinder ratios, 986  
 high-speed, sizes and performances of, 990, 991  
 non-condensing, 990  
 sequence of cranks in, 986  
 steam-jacketed, performance of, 990, 991  
 theoretical mean effective pressures, 984  
 types of, 986  
 water consumption of, 998
- Steam-engines, using superheated steam, 998-1002  
 use of reheaters in, 1004  
 valve-rods, dimensions of, 1038  
 Walschaerts valve-gear, 1064  
 water consumption of, 967, 975, 987-1006  
 water consumption from indicator-cards, 975  
 with variable loads, wasteful, 964  
 with sulphur-dioxide addendum, 1007  
 wrist-pin, dimensions of, 1029
- Steam-pipes,** 882-885  
 copper, strength of, 882  
 copper, tests of, 882  
 failures of, 882  
 for engines, 879  
 for marine engines, 880  
 proportioning for minimum loss by radiation and friction, 880  
 riveted-steel, 883  
 uncovered, loss from, 884  
 underground, condensation in, 884  
 valves in, 883  
 wire-wound, 882
- Steam turbines,** 1083-1095  
 and gas-engine, combined plant of, 1014
- Steam turbines and steam-engines compared, 1005, 1092  
 effect of pressure, vacuum and superheat, 1090  
 effect of vacuum on, 1088  
 efficiency of, 1087  
 heat consumption of ideal engine, 1091  
 impulse and reaction, 1082, 1087  
 low-pressure, 1069  
 low-pressure, combined with high-pressure reciprocating engine, 1383  
 most economical vacuum for, 1075  
 Rankine cycle ratio of, 1089  
 reduction gear for, 1095  
 speed of the blades, 1086  
 steam consumption of, 1088, 1092  
 testing oil for, 1244  
 tests of, 1088  
 theory of, 1084  
 using exhaust, from reciprocating engines, 1093, 1383  
 30,000 K.W., 1092
- Steel,** 475-511  
 analyses and properties of, 476  
 and iron, classification of, 436  
 alloy, heat treatment of, 502-504  
 aluminum, 496  
 annealing of, 484, 492  
 axle, effect of heat treatment on, 479  
 axles, specifications for, 507, 509  
 axles, strength of, 354  
 bars, effect of nicking, 485  
 beams, safe load on, 298  
 bending tests of, 478  
 Bessemer basic, ultimate strength of, 476  
 Bessemer, range of strength of, 478  
 blooms, weight of, table, 190  
 bridge-links, strength of, 353  
 brittleness due to heating, 483  
 burning carbon out of, 485  
 burning, overheating, and restoring, 481  
 Campbell's formulæ for strength of, 477  
 castings, 489, 510  
 castings, specifications for, 489, 510  
 castings, strength of, 355  
 cementation or case-hardening of, 1291  
 chrome, 496  
 chromium-vanadium, 500-502  
 chromium-vanadium spring, 424  
 cold-drawn, tests of, 361  
 cold-rolled, tests of, 361  
 color-scale for tempering, 493  
 comparative tests of large and small pieces, 480

- Steel, copper-, 499  
   corrosion of, 467, 468  
   crank-pins, specifications for, 507  
   critical point in heat treatment of, 480  
   crucible, 475, 490-494  
   crucible, analyses of, 490, 494  
   crucible, effect of heat treatment, 481, 491  
   crucible, selection of grades of, 490  
   crucible, specific gravities of, 490  
   dangerous, containing manganese sulphide, 486  
   effect of annealing, 479  
   effect of annealing on grain of, 479  
   effect of annealing on magnetic capacity, 483  
   effect of cold on strength of, 464  
   effect of finishing temperature in rolling, 478  
   effect of heating, 481  
   effect of heat on grain, 479, 491  
   effect of oxygen on strength of, 477  
   effect of vibration and load on, 278  
   electric conductivity of, 477  
   endurance\* of, under repeated stresses, 487  
   expansion of, by heat, 566  
   eye-bars, test of, 360  
   failures of, 486  
   fatigue resistance of, 500  
   fire-box, homogeneity test for, 508  
   fluid-compressed, 488  
   for bridges, specifications of, 504, 505  
   for car-axles, specifications, 507, 509  
   for different uses, analyses of, 505-510  
   forgings, annealing of, 482  
   forgings, oil-tempering of, 482  
   forgings, specifications for, 506  
   for rails, specifications, 508  
   for ships, specifications of, 507  
   for steam boilers, 913  
   hardening of soft, 479  
   Harveyizing, 1291  
   heating in a lead bath, 492  
   heating in melted salts by an electric current, 492  
   heating of, for forging, 492  
   heat treatment of Cr-Va steel, 502  
   high carbon, resistance of, to shock, 277  
   high-speed tool, 494  
   high-speed tool, emery wheel for grinding, 1263, 1314  
   high-speed tool, Taylor's experiments, 1261  
   high-speed tool, tests of, 1269
- Steel, high-strength, for shipbuilding, 507  
   ingots, segregation in, 487  
   life of, under shock, 276  
   low strength of, 477  
   low strength of, due to insufficient work, 478  
   manganese, 494  
   manganese, resistance to abrasion of, 495  
   manufacture of, 475  
   melting temperature of, 555  
   mixture of, with cast iron, 453  
   Mushet, 490  
   nickel, 497  
   nickel, tests of, 497  
   nickel-vanadium, 499  
   of different carbons, uses of, 494  
   open-hearth, range of strength of, 478  
   plates (*see* Plates, steel)  
   quench-bend tests of, for boilers, 913  
   rails, electric resistance of, 1416  
   rails, specifications for, 508  
   rails, strength of, 353  
   range of strength in, 478  
   recalescence of, 480  
   relation between chemical composition and physical character of, 476  
   rivet, shearing resistance of, 430  
   rivets, specifications for, 505  
   shearing strength of, 362  
   sheets, weight of, 183  
   soft, quenching test for, 507  
   specific gravity of, 486  
   specifications for, 504-511  
   splice-bars, specifications for, 509  
   spring, strength of, 355  
   springs (*see* Springs, steel)  
   static and dynamic properties of, 500  
   strength of, Campbell's formulæ for, 477  
   strength of, Kirkaldy's tests, 353  
   strength of, variation in, 478
- Steel, structural**, annealing of, 484  
   effect of punching and shearing, 483  
   punching of, 483  
   punching and drilling of, 485  
   riveting of, 484  
   shapes, properties of, 305-321  
   specifications for, 504  
   treatment of, 483-485  
   upsetting of, 484  
   welding of, forbidden, 484
- Steel struts, formulæ for, 285  
   tempering of, 493  
   tensile strength of, at high temperatures, 463  
   tensile strength of, pure, 477  
   tires, specifications for, 509  
   tires, strength of, 354



- Steel tool, composition and heat treatment of, 1265  
 tool, heating of, 492  
 tool, high-speed, 1265  
 tungsten, 496  
 used in automobile construction, 510  
 very pure, low strength of, 477  
 water-pipe, 351  
 welding of, 484, 498  
 wire gage, tables, 30  
 working of, at blue heat, 482  
 working stresses in bridge members, 287
- Stefan and Boltzman law of radiation, 579
- Stellite, alloy for cutting tools, 1269
- Sterro metal, 393
- St. Gothard tunnel, loss of pressure in air-pipes in, 620
- Stoker, Riley, 919  
 Taylor gravity underfeed, 919
- Stokers, mechanical, for steam-boilers, 918  
 underfeed, 919
- Stone-cutting with wire, 1309  
 strength of, 357, 370  
 weight and specific gravity of, table, 177
- Storage batteries, 1425-1428  
 batteries, Edison alkaline, 1428  
 batteries, rules for care of, 1427  
 of steam heat, 927, 1014
- Storms, pressure of wind in, 627
- Stove foundries, cupola charges in, 1250
- Stoves, for heating compressed-air, efficiency of, 641
- Straight-line formula for columns, 285  
 formula for boiler efficiency, 896
- Strain and stress, 272
- Strand, steel wire, for guys, 255
- Straw as fuel, 839
- Stream, open, measurement of flow, 760
- Streams, fire, 749-752 (*see* Fire streams)  
 running, horse-power of, 765
- Street-lighting installations, 1476  
 kinds of, 1472
- Strength** and specific gravity of  
 cast iron, 452  
 compressive, 281-283  
 compressive, of woods, 368  
 loss of, in punched plates, 424
- Strength of aluminum**, 381  
 aluminum-copper alloys, 396  
 anchor forgings, 353  
 basic Bessemer steel, 476  
 belting, 357  
 blocks for hoisting, 1181  
 boiler-heads, 337, 338  
 boiler-plate at high temperatures, 463  
 bolts, 348  
 brick, 358
- Strength of brick and stone, 370-372  
 bridge-links, 353  
 bronze, 356, 384  
 canvas, 357  
 castings, 352  
 cast iron, 444-447  
 cast-iron beams, 451  
 cast-iron columns, 289  
 cast-iron cylinders, 452  
 cast-iron flanged fittings, 452  
 cast iron, relation to size of bar, 444  
 cast-iron water-pipes, 196, 452  
 cement mortar, 372  
 chain cables, tables, 264, 265  
 chains, table, 264, 265  
 chalk, 371  
 columns, 283-293, 1389  
 copper at high temperatures, 368  
 copper plates, 356  
 copper-tin alloys, 385  
 copper-tin-zinc alloys, graphic representation, 388  
 copper-zinc alloys, 388  
 cordage, table, 410, 415, 1218  
 crank-pins, 1027  
 electro-magnet, 1431  
 flagging, 373  
 flat plates, 336  
 floors, 1390-1393  
 German silver, 356  
 glass, 365  
 granite, 357  
 gun-bronze, 386  
 hand and hydraulic riveted joints, 425  
 ice, 368  
 iron and steel, effect of cold on, 464  
 iron and steel pipe, 363  
 lime-cement mortar, 372  
 limestone, 371  
 locomotive forgings, 353  
 Lowmoor iron bars, 352  
 malleable iron, 454, 453  
 marble, 357  
 masonry materials, 371  
 materials, 272-379  
 materials, Kirkaldy's tests, 352-358  
 perforated plates, 425  
 phosphor-bronze, 395  
 Portland cement, 358  
 riveted joints, 359, 424-435  
 roof trusses, 547  
 rope, 357, 411, 1218  
 sandstone, 371  
 silicon-bronze wire, 395  
 soapstone, 371  
 spring steel, 355  
 spruce timber, 367  
 stayed surfaces, 338  
 steam-boilers, 908-918  
 steel axles, 354  
 steel castings, 355  
 steel, formulæ for, 476, 477

- Strength of steel propeller-shafts, 354  
 steel rails, 353  
 steel tires, 354  
 structural shapes, 305-321  
 timber, 368  
 twisted iron, 280  
 unstayed surfaces, 337  
 various sheet metals, 356  
 welds, 264, 355  
 wire, 357, 358  
 wire and hemp rope, 356, 357  
 wrought-iron columns, 285  
 yellow pine, 368  
 zinc plates, 370
- Strength, range of, in steel, 478  
 shearing, of iron and steel, 362  
 shearing, of woods, table, 367  
 tensile, 278  
 tensile, of iron and steel at high temperatures, 463  
 tensile, of pure steel, 477  
 torsional, 334  
 transverse, 297-300
- Stress and strain, 272  
 due to temperature, 335
- Stresses allowed in bridge members, 287  
 combined, 335  
 effect of, 272  
 in framed structures, 541-548  
 in plating of bulkheads, etc., due to water-pressure, 338  
 in steel plating due to water pressure, 338  
 produced by shocks, 276
- Structural materials, permissible stresses in, 1387, 1388  
 shapes, elements of, 294  
 shapes, moment of inertia of, 295  
 shapes, radius of gyration of, 295  
 shapes, steel (*see* Steel, structural, *also* Beams, angles, etc.)  
 steel shapes, dimensions and weights, 302-305  
 steel shapes, properties of, 305-321  
 work, rivet spacing for, 321, 322
- Structures, framed, stresses in, 541-548
- Strut, moving, 536
- Struts, steel, formulæ for, 285  
 strength of, 283  
 wrought-iron, formulæ for, 285
- Stub gear teeth, 1167
- Stud bolts, 237
- Stumpf uniflow engine, 997
- Suction lift of pumps, 788
- Sugar manufacture, 839
- Sugar solutions, concentration of, 572
- Sulphate of lime, solubility of, 571
- Sulphur-dioxide refrigerating-machine, 1345
- Sulphur - dioxide - addendum to steam-engine, 1007  
 dioxide, properties of, 1338  
 influence of, on cast iron, 438  
 influence of, on steel, 476
- Sum and difference of angles, functions of, 68
- Sun, heat of, as a source of power, 1015
- Superheated steam, economy of steam-engines with, 998  
 steam, effect of on steam consumption, 998  
 steam, practical application of, 1002
- Superheating, economy due to, 1006  
 in locomotives, 1126
- Surface condensers, 1069  
 of sphere, table, 126, 127
- Surfaces of geometrical solids, 61-66  
 of revolution, quadrature of, 77  
 unstayed flat, 337
- Suspension cableways, 1205
- Sweet's slide-valve diagram, 1054
- Symbols, chemical, 173  
 electrical, 1477
- Synchronous converters, 1453  
 generators, 1448, 1453  
 -motor, 1463
- T**-CONNECTIONS, trans-  
 formers, 1452  
 T-shapes, properties of Carnegie steel, table, 313-315
- T-slots, T-bolts and T-nuts, 1321
- Tackle, hoisting, 1182
- Tackles, rope, efficiency of, 415
- Taggers, tin, 192
- Tail-rope, system of haulage, 1203
- Tanbark as fuel, 838
- Tangent of an angle, 66
- Tangents of angles, table of, 170-172
- Tangential or impulse water wheels, tables of, 779
- Tanks and cisterns, number of barrels in, 134  
 capacities of, tables, 132-134  
 with flat sides, plating and framing for, 339
- Tap-drills, sizes of, 235, 236, 1320  
 for pipe taps, 201
- Taper pins, 1321  
 to set in a lathe, 1261
- Tapers, Jarno, 1319  
 Morse, 1319
- Tapered wire rope, 1208
- Taps, A. S. M. E. standard, 235, 236
- Tapping and threading, speeds for, 1290
- Taylor's experiments on cutting tools of high-speed steel, 1261
- Taylor's rules for belting, 1143
- Taylor's theorem, 78

- Taylor-White high-speed tools, cutting speeds of, 1266
- Teeth of gears, forms of, 1162-1167 of gears, proportions, 1159, 1161
- Telegraph poles, tubular, 206 -wire, tests of, table, 250
- Telpherage, 1196
- Temperature**, absolute, 567 and humidity, comfortable, 685 coefficient of resistance of copper, 1403 conversion table, 552 determination of by color, 558 determinations of melting-points, 554, 559 effect of on strength, 368, 463-465 -entropy diagram, 600 -entropy diagram of water and steam, 602 of fire, 817, 818 rise of, in combustion of gases, 818 stress due to, 335
- Temper carbon, in cast-iron, 439
- Tempering, effect of, on steel, 493 oil, of steel forgings, 482 steel, change of shape due to, 1291
- Tenacity of different metals, 180 of metals at various temperatures, 368, 463-465
- Tensile strength (*see* Strength) strength, increase of, by twisting, 280 tests, precautions in making, 279 tests, specimens for, 280
- Tension and flexure, combined, 335 and shear, combined, 335
- Terne-plate, or roofing tin, 193
- Terra cotta, weight of, 196
- Tests**, compressive (*see* Compressive strength) of steam-boilers, rules for, 899-908 of steam-engines, rules for, 1015 of strength of materials (*see* Strength) quench-bend, of steel 913 tensile (*see* Strength and Tensile strength)
- Thermal capacity, 562 storage, 927, 1014 units, 560
- Thermit process, 401 welding process, 488
- Thermodynamics, 597-603 laws of, 598
- Thermometer, air, 557 centigrade and Fahrenheit compared, tables, 550
- Threads, pipe, standard, 201, 217
- Threading and parting tools, speed of, 1268 and tapping, speeds for, 1290 pipe, force required for, 363
- Three-phase circuits, 1445 transmission, rule for sizes of wires, 1459
- Throttle valves, size of, 880
- Thrust bearings, 1232
- Tides, utilization of power of, 787
- Ties, railroad, required per mile of track, 245
- Tiles, weight of, 196
- Timber** (*see also* Wood) beams, safe loads, 1387, 1393 beams, strength of, 368 expansion of, 367 measure, 20 preservation of, 368 strength of, 368-369 table of contents in feet, 21 to compute volume of square, 21
- Time, measures of, 20
- Tin, alloys of (*see* Alloys) lined iron pipe, 227 plates, 192-194 properties of, 179
- Tires, locomotive, shrinkage fits, 1324 steel, friction of on rails, 1219 steel, specifications for, 509 steel, strength of, 354
- Titanium, additions to cast-iron, 439, 451 -aluminum alloy, 401
- Tobin bronze, 392
- Toggle-joint, 536
- Tonnage of vessels, 1369
- Tons per mile, equivalent of, in lbs. per yard, 27
- Tools**, cutting, durability of, 1268 cutting, effect of feed and depth of cut on speed of, 1264 cutting, in small shops, best method of treatment, 1268 cutting, interval between grindings of, 1264 cutting, pressure on, 1264 cutting, use of water on, 1264 economical cutting speed of, 1268 forging and grinding of, 1263 high speed, table of cutting speeds, 1266 machine (*see* Machine tools) parting and thread-cutting, speed of, 1268 standard planing, 1271
- Tool-steel** (*see also* Steel) best quality, 1265 high-speed, composition and heat-treatment of, 1265 high-speed, new (1909), tests of, 1269 high-speed, Taylor's experiments, 1265 in small shops, best treatment of, 1268 of different qualities, 1268
- Toothed-wheel gearing, 539, 1157-1180



- Torque computed from watts and revolutions, 1436  
horse-power and revolutions, 1436  
of an armature, 1435
- Torsion and compression combined, 335  
and flexure combined, 335  
elastic resistance to, 334  
of shafts, 1030, 1130  
tests of shafting, 361
- Torsional strength, 334
- Track bolts, 244, 245  
spikes, 245
- Tractive force of locomotive, 1112
- Tractrix, Schiele's anti-friction curve, 50
- Train resistance, electric cars, 1415  
loads, average, 1125
- Trains, railroad, resistance of, 1108  
railroad, speed of, 1187
- Trammels, to describe an ellipse with, 45
- Tramways, compressed-air, 652  
wire-rope, 1204
- Transformers, constant current, 1453  
electrical, 1451  
efficiency of, 1451  
primary and secondary of, 1451
- Transmission**, compressed-air (*see* Compressed-air)  
electric, 1410, 1457  
electric, area of wires, 1410, 1457  
electric, economy of, 1411  
electric, efficiency of, 1411  
electric, weight of copper for, 1411, 1457  
electric, wire table for, 1413, 1457  
hydraulic-pressure (*see* Hydraulic-pressure transmission)  
of heat (*see* Heat)  
of power by wire-rope (*see* Wire-rope), 1208-1213  
pneumatic postal, 1201  
rope (*see* Rope-driving)  
rope, iron and steel, 256, 257  
wire-rope (*see* Wire-rope)
- Transporting power of water, 755
- Transverse strength, 297-300
- Trapezium and Trapezoid, 54
- Trapezoidal rule, 56
- Triangles, mensuration of, 54  
problems in, 41  
solution of, 69  
spherical, 63
- Trigonometrical computations by slide rule, 83  
formulae, 68  
functions, logarithmic, 167  
functions, table, 170-172
- Trigonometry, 66-70
- Triple effect evaporators, 570
- Triple-expansion engine (*see* Steam-engines)
- Triple-riveted joints, working pressures on boilers with, 917
- Troostite, 480
- Trough plates, properties of, 308
- Troy weight, 19
- Trusses, bridge, stresses in, 543-547  
roof, stresses in, 547
- Tubes** (*see also* Pipe)  
aluminum 226  
aluminum bronze, 397  
boiler (*see* Steam-boiler tubes)  
boiler, table, 204  
boiler, used as columns, 336  
brass, seamless, 224, 225  
collapse of, formulæ for, 341-344  
collapse of, tests of, 341-344  
collapsing pressure of, table, 334  
copper, 225  
expanded, holding power of, 364, 916  
lead and tin, 227  
of different materials, weight of, 181  
seamless, 222-225  
steel, cold-drawn, Shelby, 223  
surface per foot of length, 224
- Tube-plates, steam-boiler, rules for, 914
- Tube-spacing in steam-boilers, 916
- Tungsten and aluminum alloy, 399  
electric lamps, 1473  
steel, 496
- Turbines, steam (*see* Steam-turbines)  
fall-increaser for, 778  
of 13,500 H.P., 778  
rating and efficiency of, 774  
wheel tables, 772, 776, 777  
wheels, 768-777  
wheels, proportions of, 768-772  
wheels, tests of, 773
- Turf or peat, as fuel, 838
- Turnbuckles, 243
- Tuyeres for cupolas, 1247
- Twist-drill (*see* Drills)  
and steel wire gages, 1286  
gage, table, 30  
sizes and speeds, 1285
- Twisted steel bars, strength of, 280
- Two-phase currents, 1445
- Type-metal, 408
- U**EHLING and Steinbart pyrometer, 557  
Underwriters' rules for electrical wiring, 1410
- Unequal arms on balances, 20
- Uniflow steam-engines, Stumpf, 997
- Unions, pipe fittings, 207
- Unit of evaporation, 886  
of force, 512  
of heat, 560  
of power, 528  
of work, 528

- Units, electrical and mechanical, equivalent values of, 1399  
 electrical, relations of, 1397  
 of the magnetic circuit, 1399
- United States, population of, 11  
 standard sheet metal gage, 29
- Unstayed surfaces, strength of, 337
- Upsetting of structural steel, 484
- V**-NOTCH recording water meter, 759
- Vacuum at different temperatures, 788  
 drying in, 573  
 for turbines, most economical, 1075  
 high, advantage of, 1078  
 high, influence of on steam-engine economy, 1001  
 inches of mercury and absolute pressure, 1071  
 pumps, 806  
 systems of steam heating, 702
- Valves and elbows, friction of air in, 624  
 and fittings, loss of pressure due to, 747, 748  
 and pipe fittings, description and sizes, 206-208  
 for superheated steam, 882  
 in steam pipes, 883  
 pump, 792, 793  
 straight-way gate, 217, 218
- Valve-gear, Stephenson, 1062  
 Walschaerts, 1064
- Valve-stem or rod, design of (*see* Steam-engines), 1038
- Vanadium-chrome steel, 500-502  
 -copper alloys, 395  
 effect of on cast iron, 439, 450  
 -nickel steels, 499  
 steel spring, 424
- Vapor and gases, mixtures of, 604  
 pressures of various liquids, 844  
 saturation point of, 604  
 water, and air mixture, weight of, 610-613
- Vapors used in refrigerating, properties of, 1341
- Varnishes, 471
- Velocity, angular, 522  
 due to falling a given height, 524  
 of gas in chimneys, 951  
 parallelogram of, 523  
 table of height corresponding to a given, 523
- Ventilation (*see also* Heating and Ventilation)
- Ventilating ducts, quantity of air carried by, 683  
 fans, 653-660, 672
- Ventilation by chimneys, 712  
 by steam-jet, 679  
 cooling air for, 710  
 of mines (*see* Mine-ventilation)  
 of mines, equivalent orifice, 715
- Ventilation problems, standard values in, 687  
 standards of, 686
- Ventilators, centrifugal for mines, 672
- Venturi meter, 758
- Versed sine of an arc, 67  
 sines, table, 170-172
- Verticals, formulæ for strains in, 545
- Vessels (*see also* Ships)  
 framing of, table, 339
- Vibrations in engines, preventing, 1008
- Vis-viva, 528
- Volumes of revolution, cubature of, 77
- Volt, definition of, 1397
- Voltages used in long-distance transmission, 1459
- Vulcanized India rubber, 378
- W**ALLS of buildings, thickness of, 1388  
 of warehouses, factories, etc., 1388  
 windows, etc., heat loss through, 688
- Walschaerts valve-gear, 1064
- Warren girder, stresses in, 546
- Washers, cast and wrought, tables of, 242, 243
- Washing of coal, 833
- Water**, 716-726  
 abrading power of, 755  
 amount of to develop a given horse-power, 784  
 analysis of, 722  
 as a lubricant, 1246  
 boiling-point at various barometric pressures, 608  
 boiling-point of, 719  
 comparison of head in feet with various units, 718  
 compressibility of, 720  
 conduits, long, efficiency of, 766  
 consumption of locomotives, 1122  
 consumption of steam-engines (*see* Steam-engines)  
 current motors, 765  
 drums for boilers, 913  
 erosion and abrading by, 755  
 flow of (*see* Flow of water)  
 flowing in a tube, power of, 765  
 flowing, measurement of, 757-764  
 freezing-point of, 719  
 frictional resistance of surfaces moved in, 756  
 -gas, 846, 859-864  
 -gas analyses of, 860  
 -gas, manufacture of, 859  
 -gas plant, efficiency of, 861  
 -gas plant, space required for, 862  
 hammer, 749  
 hardness of, 723

- Water, head of, 718**  
 heating of, by steam coils, 591  
 heat-units per pound of, 717  
 horse-power required to raise, 788  
 impurities of, 720  
 in pipes, loss of energy in, 812  
 jets, vertical, 749  
 meter, V-notch recording, 759  
 meters, capacity of, 749  
 pipe, cast-iron, transverse strength of, 452  
 pipes, compound with branches, 746  
 -power, 765  
 -power, plants, high pressure, 785  
 -power, value of, 766  
 pressure on vertical surfaces, 719  
 pressure per square inch, equivalents of, 27, 718  
 pressures and heads, table, 718  
 prices charged for in cities, 749  
 pumping by compressed air, 808  
 purification of, 723-726  
 -softening apparatus, 724  
 specific heat of, 564, 720  
 total heat and entropy of, 869, 871-873  
 tower (*see* Stand-pipe)  
 tower at Yonkers, N. Y., 350  
 transporting power of, 755  
 under pressure, energy of, 765  
 units of pressure and head, 718  
 vapor and air mixture, weight of, 610-613  
 velocity of, in open channels, 755  
 weight at different temperatures, 716, 717  
 weight of one cubic foot, 27  
 -wheels, 768  
 -wheels, jet, power of, 785  
 -wheels, Pelton, 779  
 -wheels, tangential, 779  
 -wheels, tangential, choice of, 780  
 -wheels, tangential, table, 782  
**Waterfall, power of a, 765**  
**Waves, ocean, power of, 786**  
**Weathering of coal, 830**  
**Wedge, 537**  
 Wedge, volume of, 62  
**Weighing on an incorrect balance, 20**  
**Weight and specific gravity of materials, 174-177 (*see also* Material in question)**  
 definition of, 511  
 measures of, 19  
**Weights and measures, 17-27**  
**Weir dam measurement, 762**  
 flow of water over, 762  
 trapezoidal, 764  
 triangular or V-notch, 759  
**Welds, strength of, 355**  
**Welding by oxy-acetylene flame, 488**  
**Welding, electric, 1419**  
 electric arc, 1419  
 of steel, 484, 487  
 process, the thermit, 488  
**Well, artesian, pumping by compressed air, 810**  
**Welsbach gas lights, standard sizes, 1474**  
**Wheat, weight of, 180**  
**Wheel and axle, 539**  
**Wheels, turbine (*see* Turbine wheel)**  
**Whipple truss, 544**  
**White-metal alloys, 407**  
**Whitworth process of compressing steel, 488**  
**Wiborgh air-pyrometer, 555**  
**Wildwood pumping-engine, high economy of, 805**  
**Willans law of steam consumption, 991**  
**Wind, 626, 627**  
 force of, 627  
 loads on roofs, 191  
 pressure of, in storms, 627  
 strain on stand-pipes, 349  
**Winding engines (*see* Hoisting engines) 1186**  
**Windlass, 539**  
 differential, 540  
**Windows, loss of heat through, 688**  
**Windmills, 627-632**  
 capacity and economy, 627-632  
**Wire, aluminum, properties of, 248, 1414**  
 aluminum-bronze, 248  
 brass, properties of, 248  
 brass, weight of, table, 229  
 copper, hard-drawn, specification for, 251, 252  
 copper, rule for resistance of, 1406  
 copper, stranded, 253  
 copper, telegraph and telephone, 251, 252  
 copper, weight of bare and insulated, 252  
 gages, tables, 28  
 galvanized, for telegraph and telephone lines, 250  
 galvanized iron, specifications for, 250  
 galvanized steel strand, 255  
 insulated copper, 252  
 nails, 246, 247  
 of different metals, 248  
 phosphor-bronze, 248  
 piano, strength of, 250  
 platinum, properties of, 248  
 plow steel, 250  
 silicon-bronze, 248, 395  
 steel, properties of, 249  
 stranded feed, table, 253  
 telegraph, tests of, 250  
 weight per mile-ohm, 250  
 -wound fly-wheels, 1052  
**Wires of various metals, strength of, 358**



- Wires, sag of between poles, 1432
- Wire-rope**, 253-263  
 bending curvature of, 1213  
 bending of, 254  
 breaking strength of, 254, 1209  
 exposure to heat, 256  
 extra flexible, 258, 259  
 flat, 260, 261  
 flattened strand, 258, 261  
 flexible hoisting, 258, 259  
 galvanized, 255, 262  
 galvanized steel hawser, 262  
 haulage (*see* Haulage)  
 horse-power transmitted by, 1210  
 iron and steel, table of strength of, 261, 410  
 locked, 262  
 notes on use of, 254, 256  
 plow steel, 257-259  
 protection of, 256  
 radius of curvature of, 1213  
 sag or deflection of, 1211  
 sheaves for, 1208, 1211  
 splicing of, 263  
 steel-clad hoisting, 260  
 strength of, 356  
 table of strength of, 410  
 tapered, 1208  
 tramways, 1204  
 varieties and uses, 254, 256
- Wire-rope transmission**, deflection of rope, 1207, 1211  
 inclined, 1212  
 limits of span, 1212  
 long distance, 1212  
 of power by, 1208  
 sheaves for, 1211
- Wiring rules, Underwriters', 1410  
 table for direct currents, 1413  
 table for three-phase transmission lines, 1459
- Wohler's experiments on strength of materials, 275
- Wood** (*see also* Timber)  
 as fuel, 835, 836  
 composition of, 835  
 drying of, 368  
 expansion of, by heat, 368  
 expansion of, by water, 368  
 heating value of, 835  
 holding power of bolts in, 346  
 nail-holding power of, 346, 347  
 screws, 236  
 screws, holding power of, 346  
 strength of, 368, 369
- Wood, strength of, Kirkaldy's tests, 358  
 weight of, 181  
 weight and specific gravity of, table, 176  
 weight and heating values of, 835  
 weight per cord, 181
- Woods, American shearing strength of, 367  
 tests of, 366
- Wood-working machinery, power required for, 1303
- Wooden fly-wheels, 1051  
 stave pipe, 218, 735
- Woodruff key, 1331, 1332
- Wool compound engines, 977
- Wootten locomotive, 1114
- Work, definition of, 27, 528  
 energy, power, 528  
 of accelerated rotation, 529  
 of acceleration, 529  
 of a man, horse, etc., 532-534  
 of friction, 1229
- Worm gearing, 540, 1168
- Wrist-pins, dimensions of, 1029
- Wrought-iron**, chemical composition of, 460  
 effect of rolling on strength of, 460  
 manufacture of, 459  
 slag in, 460  
 specifications, 461, 462  
 strength of, 352, 359, 459-463  
 strength of, at high temperatures, 463  
 strength of, Kirkaldy's tests, 352
- Y**ACHT rigging, galvanized steel rope, 255  
 Yield point, 273
- Z**-BARS, Carnegie, property of, 316  
 Zero, absolute, 567, 868
- Zeuner's slide-valve diagram, 1055
- Zinc alloys (*see* Alloys)  
 plates, strength of, 370  
 properties of, 179  
 sheet, weight of, table, 228  
 use of in steam-boilers, 931
- Zirconia, 270
- Zone of spheroid, 64  
 of spindle, 65  
 spherical, 64











THE LIBRARY OF CONGRESS





LIBRARY OF CONGRESS



0 021 213 158 1