

505.73

THE  
AMERICAN  
JOURNAL OF SCIENCE.

EDITOR: EDWARD S. DANA.

ASSOCIATE EDITORS

PROFESSORS GEORGE L. GOODALE, JOHN TROWBRIDGE,  
W. G. FARLOW AND WM. M. DAVIS, OF CAMBRIDGE,

PROFESSORS ADDISON E. VERRILL, HORACE L. WELLS,  
L. V. PIRSSON AND H. E. GREGORY, OF NEW HAVEN,

PROFESSOR GEORGE F. BARKER, OF PHILADELPHIA,  
PROFESSOR HENRY S. WILLIAMS, OF ITHACA,  
PROFESSOR JOSEPH S. AMES, OF BALTIMORE,  
MR. J. S. DILLER, OF WASHINGTON.

---

FOURTH SERIES

VOL. XX—[WHOLE NUMBER, CLXX.]

WITH 15 PLATES.

---

NEW HAVEN, CONNECTICUT.

1905

193868

THE TUTTLE, MOREHOUSE & TAYLOR PRESS.

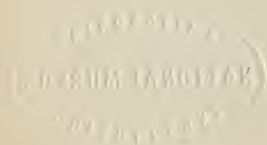



## CONTENTS TO VOLUME XX.

### Number 115.

	Page
ART. I.—Iodine Titration Voltameter ; by D. A. KREIDER ..	1
II.—Handling of Precipitates for Solution and Reprecipitation ; by F. A. GOOCH .....	11
III.—Estimation of Sulphites by Iodine ; by R. H. ASHLEY ..	13
IV.—Revision of the New York Helderbergian Crinoids ; by M. TALBOT. (With Plates I-IV) .....	17
V.—Petrographic Province of Central Montana ; by L. V. PIRSSON .....	35
VI.— <i>Croomia pauciflora</i> ; by T. HOLM .....	50
VII.—Relative Proportion of Radium and Uranium in Radio-active Minerals ; by E. RUTHERFORD and B. B. BOLTWOOD .....	55
VIII.—Side Discharge of Electricity ; by J. TROWBRIDGE ..	57
IX.—Effect of High Temperatures on the Rate of Decay of the Active Deposit from Radium ; by H. L. BRONSON ..	60

### SCIENTIFIC INTELLIGENCE.

- Chemistry and Physics*—Amounts of Neon and Helium in the Air, W. RAMSAY : Radio-activity of Thorium, O. SACKUR, 65.—Use of Quartz Apparatus for Laboratory Purposes, MYLIUS and MEUSSER : Permeability of Quartz Vessels to Gases, BERTHELOT : Outlines of Inorganic Chemistry, A. GOOCH and C. F. WALKER, 66.—Spectroscopic Analysis of Gas Mixtures, J. E. LILIENFELD : FitzGerald-Lorentz Effect, MORLEY and MILLER, 67.—Normal Element ; Influence of Character of Excitation upon Structure of Spectral lines : Radio-active Minerals, R. J. STRUTT : Absence of excited Radio-activity due to temporary Exposure to  $\gamma$ -Rays, 68.—Handbuch der Spectroscopie, H. KAYSER, 69.
- Geology and Natural History*—United States Geological Survey, 69.—Preliminary Report on the Geology and Underground Water Resources of the Central Great Plains, N. H. DARTON, 70.—Origin of the Channels surrounding Manhattan Island, New York, W. H. HOBBS, 71.—Isomorphism and Thermal Properties of the Feldspars, A. L. DAY and E. T. ALLEN, 72.—Tin Deposits of the Carolinas, J. H. PRATT and D. B. STERRETT : Tubicolous Annelids of the Tribes Sabellides and Serpulides from the Pacific Ocean, K. J. BUSH, 75.—Student's Text-Book of Zoology, A. SEDGWICK : Preliminary Report on the Protozoa of the Fresh Waters of Connecticut, H. W. CONN, 76.—Études sur l'Instinct et les Moeurs des Insects, J.-H. FABRE : Rocky Mountain Goat, M. GRANT : Catalogue of North American Diptera (or two-winged Flies), J. M. ALDRICH : Fauna and Geography of the Maldive and Laccadive Archipelagoes, J. S. GARDINER : American Museum Journal, 77.—Cold Spring Harbor Monographs, 78.
- Miscellaneous Scientific Intelligence*—Vom Kilimandscharo zum Meru, C. UHLIG, 78.—Glacial Studies in the Canadian Rockies and Selkirks, W. H. SCHERZER : Solar Observatory of the Carnegie Institution of Washington, G. E. HALE : United States Naval Observatory : Publications of West Hendon House Observatory, Sunderland, 80.

## Number 116.

	Page
ART. X.—Mechanical Equivalent of the Heat Vaporization of Water; by R. H. HOUGH .....	81
XI.—Phosphorescence of Zinc Sulphide through the Influence of Condensed Gases obtained by Heating Rare-Earth Minerals; by C. BASKERVILLE and L. B. LOCKHART ....	93
XII.—Action of Radium Emanations on Minerals and Gems; by C. BASKERVILLE and L. B. LOCKHART .....	95
XIII.—Behavior of Typical Hydrous Bromides when Heated in an Atmosphere of Hydrogen Bromide; by J. L. KREIDER .....	97
XIV.—Glacial (Dwyka) Conglomerate of South Africa; by E. T. MELLOR .....	107
XV.—Formation of Natural Bridges; by H. F. CLELAND ..	119
XVI.—Quartz from San Diego County, California; by G. A. WARING .....	125
XVII.—Radio-active Properties of the Waters of the Springs on the Hot Springs Reservation, Hot Springs, Ark.; by B. B. BOLTWOOD .....	128
XVIII.—Genesis of Riebeckite Rocks; by G. M. MURGOCI .	133
XIX.—Purpurite, a new Mineral; by L. C. GRATON and W. T. SCHALLER .....	146

## SCIENTIFIC INTELLIGENCE.

- Chemistry and Physics*—Studies with the Liquid Hydrogen and Air Calorimeters. I. Specific Heats, J. DEWAR, 152.—Thermo-electric Junction as a Means of determining the Lowest Temperatures, J. DEWAR, 153.
- Geology*—Geology of the Vicinity of Little Falls, Herkimer County, H. P. CUSHING, 156.—Geology of the Watkins and Elmira Quadrangles, accompanied by a geologic map, J. M. CLARKE and D. D. LUTHER, 157.—Geologic map of the Tully Quadrangle, J. M. CLARKE and D. D. LUTHER, 158.—Contribution to the Paleontology of the Martinez Group, C. E. WEAVER: Faune cambrienne du Haut-Alemtejo (Portugal), J. F. N. DELGADO, 159.—Paraphorhynchus, a new genus of Kinderhook Brachiopoda, S. WELLER: Sympterura Minveri, n. g. et sp.; a Devonian Ophiurid from Cornwall, F. A. BATHER: Ancestral origin of the North American Unionidæ, or fresh-water Mussels, C. A. WHITE, 160.—Thalattosauria, a group of marine reptiles from the Triassic of California, J. C. MERRIAM: Geology of Littleton, New Hampshire, C. H. HITCHCOCK: Vorschule der Geologie, J. WALTHER, 161.—Die Moore der Schweiz mit Berücksichtigung der gesammten Moorfrage, J. FRÜH and C. SCHRÖTER, 162.—Study of Recent Earthquakes, C. DAVISON: Introduction to the Geology of Cape Colony, A. W. ROGERS, 163.—Ice Erosion Theory, a Fallacy, H. L. FAIRCHILD, 164.—Hanging Valleys, I. C. RUSSELL, 165.—Glaciation of the Green Mountains, C. H. HITCHCOCK: Ice or Water, H. H. HOWORTH, 166.
- Miscellaneous Scientific Intelligence*—United States National Museum, R. RATHBUN: Forestry; Tenth Annual Report of the Chief Fire Warden of Minnesota, C. C. ANDREWS: Les Prix Nobel en 1902: Negritos of Zambales, W. A. REED: Magnetic Survey of Japan reduced to the Epoch 1895.0 and the Sea-level, A. TANAKADATE, 167.—Beiträge zur chemischen Physiologie, F. HOFMEISTER: Du Laboratoire à l'Usine, L. HOULLEVIGUE: Traité Complet de la Fabrication des Bières, G. MOREAU and L. LÉVY, 168.

## Number 117.

	Page
ART. XX.—Development of Fenestella ; by E. R. CUMINGS. (With Plates V, VI, and VII).....	169
XXI.—Age of the Monument Creek Formation ; by N. H. DARTON .....	178
XXII.—Iodometric Determination of Aluminium in Alumin- ium Chloride and Aluminium Sulphate ; by S. E. MOODY	181
XXIII.—Secondary Origin of Certain Granites ; by R. A. DALY .....	185
XXIV.—Tychite, a New Mineral from Borax Lake, Califor- nia, and on its Artificial Production and its Relations to Northupite ; by S. L. PENFIELD and G. S. JAMIESON	217
XXV.—Modification of Victor Meyer's Apparatus for the Determination of Vapor-Densities ; by B. J. HAR- RINGTON .....	225
XXVI.—New Lower Tertiary Fauna from Chappaquiddick Island, Martha's Vineyard ; by T. C. BROWN. (With Plate VIII) .....	229
XXVII.—Production of Radium from Uranium ; by B. B. BOLTWOOD .....	239

## SCIENTIFIC INTELLIGENCE.

*Geology*—Explorations in Turkestan with an account of The Basin of Eastern Persia and Sistan. Expedition of 1903, under the direction of RAPHAEL PUMPELLY, 245.

## Number 118.

	Page
ART. XXVIII.—Ultimate Disintegration Products of the Radio-active Elements ; by B. B. BOLTWOOD .....	253
XXIX.—Use of the Rotating Cathode for the Estimation of Cadmium taken as the Sulphate ; by C. P. FLORA ..	268
XXX.—Crystallization of Luzonite ; and other Crystallo- graphic Studies ; by A. J. MOSES .....	277
XXXI.—Determining of the Optical Character of Birefract- ing Minerals ; by F. E. WRIGHT .....	285
XXXII.—Groups of Efficient Nuclei in Dust-Free Air ; by C. BARUS .....	297
XXXIII.—Studies in the Cyperaceæ ; by T. HOLM .....	301
XXXIV.—Preliminary Note on some Overthrust Faults in Central New York ; by P. F. SCHNEIDER .....	308
XXXV.—Petrography of the Tucson Mountains, Pima Co., Arizona ; by F. N. GUILD. (With Plate IX.) .....	313

## SCIENTIFIC INTELLIGENCE.

*Chemistry and Physics*—Gases produced by Actinium, DEBIERNE : New Heavy Solution, DUBOIN, 319.—Hydrolysis of very Concentrated Ferric Sulphate Solutions, RECOURA : Separation of Gold from the Metals of the Platinum Group, JANNASCH and VON MOYER : Determination of Sugar with Fehling's Solution, LAVALLE, 320.—Slow Transformation Products of Radium, E. RUTHERFORD, 321.

*Geology and Mineralogy*—Indiana, Department of Geology and Natural Resources, Twenty-ninth Annual Report, W. S. BLATCHLEY, 322.—Geological Survey of Louisiana : Geological Survey of New Jersey : Brief descriptions of some recently described Minerals, 323.

## Number 119.

	Page
ART. XXXVI.—A New Niobrara Toxochelys; by G. R. WIELAND. (With Plate X.) .....	325
XXXVII.—Contributions to the Geology of New Hampshire. I. Geology of the Belknap Mountains; by L. V. PIRSSON and H. S. WASHINGTON. (With Plate XI.)	344
XXXVIII.—The Fauna of the Chazy Limestone; by P. E. RAYMOND .....	353
XXXIX.—The Mechanical Properties of Catgut Musical Strings; by J. R. BENTON .....	383
XL.—Use of the Rotating Cathode for the Estimation of Cadmium taken as the Chloride; by C. P. FLORA...	392

## SCIENTIFIC INTELLIGENCE.

*Chemistry and Physics.*—Formation of Ozone by Ultra-violet Light, FISCHER and BRAEMER: New Reagent for Nickel, TSCHUGAEFF, 397.—Electrolytic Dissociation Theory with some of its Applications: Soils and Fertilizers: Engineering Chemistry, 398.—Text-book of Chemical Arithmetic: Text-book of Physiological Chemistry for Students of Medicine: Formation of Helium from the Radium Emanation, 399.—Blondlot's "Emission pesante": Diffusion of Nascent Hydrogen through Iron, A. WINKLEMANN, 400.—Landolt-Börnstein Physikalisch-chemische Tabellen, 401.

*Geology and Mineralogy.*—United States Geological Survey, 402.—Osteology of Baptanodon, C. W. GILMORE, 403.—Cambrian Fauna of India, C. D. WALCOTT, 404.—Catalogue of Type-Specimens of Fossil Invertebrates in the Department of Geology, U. S. National Museum, 405.—Graptolites of New York; Part I, Graptolites of the Lower Beds, R. RUEDEMANN: Mesozoic Plants from Korea, H. YABE: Paleontologia Universalis: Ninth Annual Report of the Geological Commission, Dept. of Agriculture, Cape of Good Hope, for 1904: Rock Cleavage, C. K. LEITH, 406.—Experiments on Schistosity and Slaty Cleavage, G. F. BECKER: Die Alpen im Eiszeitalter, 407.—Structural and Field Geology, J. GEIKIE: Clays and Clay Industry of Connecticut, G. F. LOUGHLIN, 408.—Geology of Western Ore Deposits: Delavan Lobe of the Lake Michigan Glacier, etc., 409.—Platinum in Black Sands from Placer Mines, D. T. DAY: Cassiterite, W. E. HIDDEN, 410.

*Miscellaneous Scientific Intelligence.*—Harvard College Observatory: Publications of the Cincinnati Observatory: Report of Director of the Yerkes Observatory, Univ. of Chicago: Carnegie Institution of Washington, 411.—Annual Report Board of Regents Smithsonian Institution: Catalogue of Collection of Birds' Eggs in the British Museum of Natural History: Bibliotheca Zoologica II, 412.

*Obituary.*—Baron FERDINAND VON RICHTHOFEN, Professor LEO ERRERA, Mr. G. B. BUCKTON, M. ELISÉE RECLUS, 412.

## Number 120.

	Page
ART. XLII.—Two New Ceratopsia from the Laramie of Converse County, Wyoming; by J. B. HATCHER. (With Plates XII, XIII.) .....	413
XLIII.—Restoration of the Horned Dinosaur Diceratops; by RICHARD S. LULL. (With Plate XIV.) .....	420
XLIII.—Triassic System in New Mexico; by CHARLES R. KEYES .....	423
XLIV.—Structure of the Upper Cretaceous Turtles of New Jersey: Agomphus; by G. R. WIELAND .....	430
XLV.—The Cambro-Ordovician Limestones of the Middle Portion of the Valley of Virginia; by H. D. CAMPBELL .....	445
XLVI.—Relations of Ions and Nuclei in Dust-free Air; by CARL BARUS .....	448
XLVII.—Additional Notes upon the Estimation of Cadmium by Means of the Rotating Cathode, and Summary; by CHARLES P. FLORA .....	454
XLVIII.—The Estimation of Cadmium as the Oxide; by CHARLES P. FLORA .....	456
XLIX.—The Mounted Skeleton of Triceratops prorsus in the U. S. National Museum; by C. SCHUCHERT. (With Plate XV.) .....	458

## SCIENTIFIC INTELLIGENCE.

*Chemistry and Physics.*—A New Formation of Diamond, SIR W. CROOKES: A New Compound of Iron, OTTO HAUSER: Nitrosyl Fluoride, RUFF and STÄUBER, 460.—The Atomic Weight of Strontium, T. W. RICHARDS: Qualitative Analysis, E. H. S. BAILEY and H. P. CADY: Charging Effect of Röntgen Rays, KARL HAHN, 461.—Emission of Negative Corpuscles by the Alkali Metals, J. J. THOMSON: A New Method of showing the Presence of Neon, Krypton, and Xenon, S. VALENTINER and R. SCHMIDT: The Mechanical Properties of Catgut Musical Strings, J. R. BENTON, 462.

*Geology and Mineralogy.*—Iowa Geological Survey, Volume XV, 463.—Summary Report of the Geological Survey Department of Canada, R. BELL: Glaciation of Southwestern New Zealand, E. C. ANDREWS, 464.—Mastodon-Reste aus dem interandinen Hochland von Bolivia, J. F. POMPECKJ: Description of New Rodents and Discussion of the Origin of Daemoneelix, O. A. PETERSON, 465.—Economic Geology of the Bingham Mining District, Utah, 466.—Economic Geology, 467.—Minerals in Rock Sections, L. MCL. LUQUER, 468.

*Miscellaneous Scientific Intelligence.*—National Academy of Sciences, 468.—The Geological Society of America: A Laboratory Guide in Bacteriology, PAUL G. HEINEMANN: British Tunicata, ALDER and HANCOCK, 469.—Catalogus Mammalium tam viventium quam fossilium, E. L. TROUËSSART: Carnegie Institution of Washington: A Handbook of the Trees of California, A. EASTWOOD, 470.

*Obituary.*—Professor DEWITT BRISTOL BRACE, Professor RALPH COPELAND, Professor D. W. VON BEZOLD, 470.

INDEX TO VOL. XX, 471.

VOL. XX.

JULY, 1905.

Established by BENJAMIN SILLIMAN in 1818.

THE  
AMERICAN  
JOURNAL OF SCIENCE.

EDITOR: EDWARD S. DANA.

ASSOCIATE EDITORS

PROFESSORS GEORGE L. GOODALE, JOHN TROWBRIDGE,  
W. G. FARLOW AND WM. M. DAVIS, OF CAMBRIDGE,

PROFESSORS ADDISON E. VERRILL, HORACE L. WELLS,  
L. V. PIRSSON AND H. E. GREGORY, OF NEW HAVEN,

PROFESSOR GEORGE F. BARKER, OF PHILADELPHIA,

PROFESSOR HENRY S. WILLIAMS, OF ITHACA,

PROFESSOR JOSEPH S. AMES, OF BALTIMORE,

MR. J. S. DILLER, OF WASHINGTON.

FOURTH SERIES

VOL. XX—[WHOLE NUMBER, CLXX.]

No. 115.—JULY, 1905.

WITH PLATES I-IV.

NEW HAVEN, CONNECTICUT.

1905

THE TUTTLE, MOREHOUSE & TAYLOR CO., PRINTERS, 123 TEMPLE STREET.

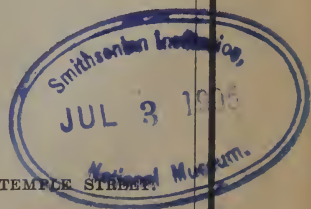

Published monthly. Six dollars per year, in advance. \$6.40 to countries in the Postal Union. Remittances should be made either by money orders, registered letters, or bank checks (preferably on New York banks).

# CRYSTALLIZED STANNITE

A small consignment direct from the silver mines in Bolivia affords new and unique examples of the following. They have been identified by high mineralogical authority.

**Stannite, Splendent crystals**, grouped in cavities of the massive mineral. The crystals are most perfectly developed and very rich in planes. The species has been known to science for over a century, but until recently only in the massive form, thus leaving its crystallographic form in question. Hence the present find is peculiarly welcome.

**Andorite.** A silver and lead sulph-antimonide. Massive and in small but characteristic crystals of highly modified orthorhombic habit. Sometimes associated with the crystallized Stannite.

---

## RARE MINERALS

Specimens are supplied by us to students and chemists for purposes of comparison and investigation; in commercial quantities for industrial uses.

---

## SYSTEMATIC COLLECTIONS OF TYPICAL SPECIMENS

In sets of twenty-five up to fifteen hundred specimens. Prices \$5.00 upwards per set, the average price for students' specimens being about twenty cents. We have supplied the leading institutions for thirty years, having lately completed a single order for over 60,000 specimens. Our material is the accepted standard both as to correct labeling and high quality.

**Free Collection Catalog**, containing lists and illustrations of General Mineral Collections, Series of Ores for Prospectors, Sets of Crystals, Series illustrating Hardness and other Physical Characters of Minerals, with Price List of Laboratory Material and Individual Specimens.

---

## FOOTE MINERAL CO.,

Established 1876, by Dr. A. E. Foote.

W. M. FOOTE, Manager.

DEALERS IN

MINERAL SPECIMENS AND COMMERCIAL RARE MINERALS,

1317 Arch Street, Philadelphia.



THE  
AMERICAN JOURNAL OF SCIENCE

[FOURTH SERIES.]

ART. I.—*An Iodine Titration Voltameter*; by D. ALBERT  
KREIDER.

THE rapidity, accuracy and sharpness of the end reaction of several of the methods of volumetric analysis, particularly of the iodometric methods, have suggested the possibility of applying them to the voltameter. A rather extensive investigation of quantitative electrolytic oxidation and reduction methods, with this aim in view, has resulted in the evolution of a titration voltameter the accuracy of which may be depended upon to about one part in ten thousand. The advantages in point of manipulation and time required, as well as its applicability to a greater range of current density, will, in the writer's opinion, make it of service in many investigations.

The basis of the method is the electrolysis of potassium iodide and the titration of the liberated iodine by sodium thio-sulphate. Herroun\* first suggested the use of iodine in this connection. He electrolyzed zinc iodide between a platinum anode and zinc cathode in a beaker; but gives the results of only one determination and leaves the method in an impracticable form.

Danneel† reports four comparative tests of Herroun's zinc iodide voltameter in series with a silver voltameter. The results show a difference of between +0.27 per cent and -1 per cent. His burette readings were made to only the nearest 0.1<sup>cc</sup>, and the total quantity of thiosulphate was small; varying from 7 to 34<sup>cc</sup>.

The work of Danneel, as well as that of Kistiakowsky‡ on a silver titration voltameter, seems never to have found its way

\* Phil. Mag. [5], xl, 91, 1895.

† Zeitschr. für Elect. Chem., iv, 154, 1897.

‡ Zeitschr. Phys. Chem., vi, 97, 1890.

into the general literature. The work of both men, on voltameters, was incidental to another research and the titles of their articles fail to afford any clue to this particular contents. My own preliminary search of possible reactions had been completed and I had settled upon the form of the iodide voltameter before I learned of the work just mentioned.

Herroun rather erroneously points to the high electrochemical equivalent of iodine as its chief advantage; this is obviously immaterial in a volumetric method. As a basis of a titration method, however, iodine has peculiar advantages in the rapid action of sodium thiosulphate upon it and in the extreme sharpness of the end reactions, intensified when desirable by the addition of starch solution. Potassium iodide is, moreover, much to be preferred to the zinc salt. It is obtainable commercially quite free from iodates and its solutions may, therefore, be acidified without the liberation of iodine, except for the very slow action of atmospheric, or dissolved, oxygen.

It is, of course, impracticable to electrolyze the potassium iodide directly, when the liberated iodine is to afford a measure of the current; this is because of the recombination of the electrode products by diffusion. Acidifying prevents this recombination, or even after it has taken place, in an acid solution the original amount of iodine is liberated, providing the iodine has not been allowed to diffuse to the cathode during the electrolysis, where it would tend to combine with hydrogen and would be irrecoverable.

A most satisfactory action is obtained when the anode is submerged in a strong aqueous solution of the potassium iodide under dilute hydrochloric acid in which the cathode is suspended. With the electrodes thus placed vertically, the anode below, the liberated iodine, because of its great density and solubility in potassium iodide, diffuses very slowly. After a run of hours, and even on subsequent standing for hours more, the solution about the cathode remains perfectly colorless and free of iodine.

#### *The Potassium Iodide Cell.*

As a cell, I have employed a side-necked test tube, fig. 1, drawn out at the bottom to a long capillary. Into the junction of this capillary a glass rod was ground. The test tube was closed by a rubber stopper with three perforations, through the middle one of which the ground glass rod passes air tight, though not so tightly as to prevent easy motion when moist. The other perforations receive the glass tubes through which the wires connect with the platinum electrodes; anode at the

bottom of the tube, cathode above. The size of the electrodes was, in the small cell,  $1.6 \times 2.7$  cm; in the large cell,  $2.5 \times 6$  cm. In the latter case the cathode was somewhat smaller and corrugated. These electrodes were bent into cylindrical form and arranged coaxially with the tube. The smaller cell had a diameter of 2 cm, length, 12 cm, length of capillary, 7 cm. Its capacity was about 30 cc; about 7 cc being required to cover the anode. The larger cell was made in the same way, of a tube 3 cm in diameter and about 15 cm in length, with a capillary about 18 cm long. With the distance of 5 cm between the nearest edges of the electrodes, the total volume required to cover the cathode was about 60 cc, about 20 cc sufficing to cover the anode.

The apparatus was filled by raising the ground glass rod and by diminished pressure, effected through the side neck, drawing up through the capillary successively the required amount of hydrochloric acid and then the strong solution of potassium iodide in water. In this way the anode is completely submerged in the concentrated solution of iodide without the use of excessive quantities. The hydrochloric acid serves as an electrolyte, permitting the separation of the electrodes sufficiently to preclude the possibility of any interaction of the electrode products.

By this method of filling the cell the iodide is sufficiently acidified, and if not too rapidly drawn in, a sharp line will mark the junction of the two solutions of different density. The electrolysis results in a quantitative liberation of iodine unless the current density is too great. In the latter case oxygen is evolved along with the iodine. With the permissible current densities indicated in Table I, so long as the potassium iodide is not impoverished about the anode, not a trace of oxygen appears and the action is entirely satisfactory. As the iodine is liberated it sinks along the electrode and by its convection effect renews the iodide at the surface of the electrode without the slightest disturbance of the supernatant acid. In all cases where the current density has not exceeded the indicated maximum, or where the duration of the current has not been such as to exhaust the iodide (so that no oxygen is evolved) the supernatant liquid remains perfectly colorless and free of iodine, and continues to show a sharp line of demarcation between the iodine solution and the acid.

Table I shows the possible current densities, potential change, and permissible time of run, under the given conditions. In the first column, the first figure represents the num-

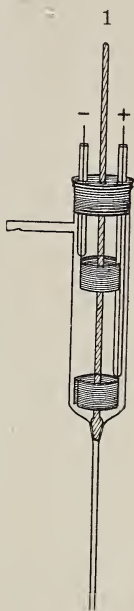

ber of grams of potassium iodide used and the second figure the volume of its solution in water. In the fifth column, where two figures are given, the first represents the fall of potential through the cell at the beginning of the experiment and the second figure that at the end of the run. The interval is found in the sixth column. An asterisk following the figures of the sixth column indicates that the current was continued until, and stopped at the moment of, the first appearance of gas on the anode. It is evident that the liberation of iodine is no longer quantitative for some time before this gas appears, the safety limit depending upon the current density. Within this safety limit the rise of potential is also not as great as that indicated in the fifth column. The fall of potential through the cell increases continuously and very regularly, after the first few minutes, in which it rises rather more rapidly. Just before the appearance of the gas the potential naturally rises quite rapidly. The gradual change of potential is doubtless due to the increased resistance of the potassium chloride solution which is formed during the electrolysis at the boundary of the two solutions. This part of the cell, especially the small one, is always considerably heated by the current, and a conspicuous line of increased density of the solution, but entirely colorless, gradually creeps up the tube to a distance of several centimeters in an hour's run. In the 7th experiment the solution became quite warm and small bubbles of gas appeared on the sides of the glass, long before there was any evidence of gas being evolved at the anode. To test the correctness of the supposition that this was merely dissolved gas, the 8th experiment was made with the cell in a water bath maintained at 9°. Under these conditions no gas appeared until it was evolved at the anode. This experiment also shows that the warming of the solution is, if anything, an advantage; due, doubtless, to the more rapid diffusion of the iodide or to the greater solubility of the iodine. In experiments 3 and 10 the current was varied; the time of run for each value of the current is given in the sixth column.

Three determinations with two of the small cells in series, each containing 2 grams of potassium iodide in 7.5<sup>cc</sup>, with a current density of 0.015 amp./ $\sqrt{\text{cm}^2}$  showed the following satisfactory agreement in the amount of thiosulphate required:

(a) $\left\{ \begin{array}{l} 31.55^{\text{cc}} \\ 31.58^{\text{cc}} \end{array} \right.$	(b) $\begin{array}{l} 28.60^{\text{cc}} \\ 28.66^{\text{cc}} \end{array}$	(c) $\begin{array}{l} 16.62^{\text{cc}} \\ 16.60^{\text{cc}} \end{array}$
---	---	---

A comparison between the values obtained by two of the iodine voltameters in series with each other and with one or more copper voltameters is shown in Table II. The titrations

in these cases were not as accurately made, nor the solutions standardized with the same care that characterized the later determinations, as will be seen from the sequel.

TABLE I.

(a) Small cell { Diam. of cell = 2<sup>cm</sup>.  
Length of cell = 12<sup>cm</sup>.  
Electrodes 1.6 × 2.7<sup>cm</sup>.  
Dist. between nearest edges of electrodes, 5<sup>cm</sup>.

	KI grms. in cc. of solution	HCl (1:4) cc.	Current (approx.) amp.	Current density (approx.) amp./cm <sup>2</sup>	P. D. Volts.	Time of run, mins.	
1	1 in 5	not measured	0.13	0.015	2.25	22*	
2	2 " 5		0.13	0.015	2.00	35*	
3	2 " 7.5	"	0.25	0.029		15	
			0.40	0.046		2 more	
			0.5	0.058		4½ more*	
4	2 " 7.5	"	0.5	0.058	7.1 to 7.8	15*	
5	2 " 7.5	20	0.5	0.058	3. " 4.7	13*	Solid iodine at anode
6	4 " 7.5	5	0.5	0.058	5. " 12.5	47*	
7	5 " 7.5	20	0.5	0.058	2.4 " 4.8	85*	Solution alkaline
8	5 " 7.5	20	0.5	0.058	2.6 " 5.8	54*	Solid iodine in large quantity at anode
(b) Large cell { Diam. of cell = 3 <sup>cm</sup> . Length of cell = 15 <sup>cm</sup> . Electrode (anode) 2.5 × 6 <sup>cm</sup> . Distance nearest edges, 5 <sup>cm</sup> .							
9	5 " 20	40	0.5	0.017	2. " 3.5	41*	Solid iodine at anode
			0.5	0.017	1.5 " 2.5	91	
10	10 " 20	40	1.0	0.033	4.1 " 4.7	3 more	Solid iodine at anode
			1.5	0.050	5.7	1 more*	

\* Gas evolved at anode.

TABLE II.

Iodine voltameter.							Cu-voltameter.		
Distance between elec- trodes, cm.	KI grms. in cc.	Cur- rent amp.	Amp./cm <sup>2</sup>	Time, mins.	Na <sub>2</sub> S <sub>2</sub> O <sub>3</sub> cc.	Copper equiv- alent, grms.	Copper grms.	Amp./cm <sup>2</sup>	
1	(a) 5.4 in 7.5	0.5	0.058	25	73.90	0.2391	0.2379	0.013	
	(b) 1.4 " 7.5				73.72	0.2385			
2	(a) 5.4 " 7.5	0.5	0.058	45	132.87	0.4202	0.4199	0.013	
	(b) 5.4 " 7.5				132.71	0.4198	0.4203		
3	5.5 " 7.5	0.5	0.058	45	134.21	0.4244	0.4234 0.4240	0.013	

*Standard Solutions.*

Sodium thiosulphate is the most convenient medium for the titration of iodine, but it is not a very satisfactory standard where great accuracy is desired. The salt is readily obtained quite pure, but there is always some uncertainty as to the amount of extraneous water the crystals may contain. Further, on long standing, especially when exposed to the light, it undergoes a slight decomposition, with deposition of sulphur. However, this decomposition is so slow that, if kept in the dark, the solution will remain quite constant for months. In all of my titrations, except those that were merely relative, I have employed an approximately decinormal solution of sodium thiosulphate, standardized against arsenious oxide, by means of an iodine solution. The purest arsenious oxide obtainable was resublimed three times and weighed from a weighing bottle. This solution also was only approximately decinormal. The weight of the arsenious oxide was carefully determined and reduced to its weight in vacuo, and the solution accurately made up to one liter at 20° in a calibrated flask. The direct employment of the arsenic solution for the titrations is undesirable because it necessitates an excess of bicarbonate and the danger of loss of iodine in the neutralization requires a complicated series of traps. Moreover, the end reaction, when starch is employed, is much slower with arsenic than with the thiosulphate. With the latter it is practically instantaneous.

*The Titrations.*

The titrations were performed in Ehrlenmeyer beakers. In filling the cell, care was always taken to draw up the last of the iodide solution as far as the ground glass joint, but without admitting air which would stir up the solutions. To avoid a possible loss of iodine through a considerable leakage of the joint and vaporization from the concentrated solution, the Ehrlenmeyer beaker containing about 150<sup>cc</sup> of water was placed under the cell during the electrolysis. The capillary extension of the cell (fig. 1) reached to the bottom of the beaker. Whenever the leakage of the ground glass joint was sufficient to allow the iodine solution to descend the full length of the capillary during an experiment, the joint was reground with the finest emery. Under these conditions a loss of iodine is impossible.

After the current was cut off, the ground glass joint was opened slightly and the cell allowed to empty slowly. The great density of the iodine solution keeps it continuously covered with a layer of water of considerable depth in the

beaker, and the supernatant acid of the cell washed out the iodine completely.

A burette of 50<sup>cc</sup> capacity was employed. This burette was carefully calibrated and was found to be surprisingly accurate. Its error indicates an extremely minute and regular taper of the tube and the graduations are such as to permit of accurate readings to 0.02<sup>cc</sup>. In fact I have felt considerable confidence in reading it to 0.01<sup>cc</sup>. This, with the strength of solution employed, was equivalent to about 0.1<sup>mg</sup> of silver. In the earlier determinations, when more than 50<sup>cc</sup> of the thiosulphate were required, the burette was in some cases refilled, which, of course, multiplied the error of reading. In other cases, where the amount of thiosulphate was approximately known, a sufficient quantity was added to the beakers from calibrated pipettes of various size, so that the additional amount required should be less than 50<sup>cc</sup>. This is, of course, less exact and impractical as well, unless the amount required is approximately known.

In the later determinations a bulb burette, fig. 2, was employed. This contained 6 bulbs, each of approximately 25<sup>cc</sup> capacity, connected by small tubes of about 2 to 3<sup>mm</sup> internal diameter. At about the middle of these tubes marks were etched in such a way as to permit readings without error of parallax. The smallness of the tubes prevented filling the burette from the top and to avoid the uncertainty of rubber connections a small side tube, also about 2 to 3<sup>mm</sup>, terminating in a funnel, *b*, was sealed on and supported by a section of cork as shown. A finger placed on *a* as the liquid is poured into *b* regulates the flow, so that air bubbles are not carried along and the burette is filled quietly and accurately. Inclining the discharge tube, as shown, is of great advantage in preventing any of the grease from the cock soiling the interior of the burette, a very troublesome feature of the usual burette.

The readings of this burette are naturally extremely accurate. It was employed in bleaching the larger part of the iodine. Experience enabled me to judge from the color about when the remaining iodine was less than that bleached by the contents of one bulb. If there was any difficulty in judging this, a comparison beaker of iodine solution could be employed. At any rate the 50<sup>cc</sup> burette, with which the titration was com-

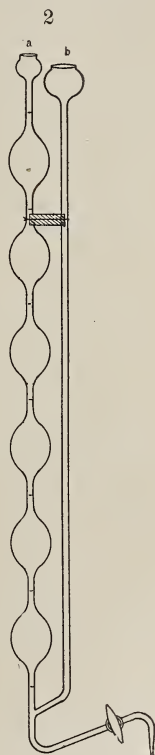

pleted, was equal to two of the bulbs, and no difficulty was experienced in keeping within that limit. In case of accidentally overstepping the amount of thiosulphate required, a measured volume of iodine solution may be added and the titration be repeated, subsequent deduction being made for the amount of thiosulphate necessary to bleach the added iodine.

The end reaction was in all cases taken as the bleaching of the iodine color, without starch. This in itself is quite delicate, and I have invariably been able to read it to a small fraction of a drop, when the beaker stood on white paper in a good indirect light. As a confirmation of the reading, 5<sup>cc</sup> of starch solution was then added and produced a faint purple color. The delicacy of this end reaction was more thoroughly appreciated when, after a number of titrations had been made successively, as in the experiments of Table III, the addition of the starch produced almost precisely the same shade of color in all, despite the fact that a very small fraction of a drop of the thiosulphate produced a distinctly perceptible change in the color.

TABLE III.

	Electrodes, cm.	Dis. bet. electrodes, cm.	KI grms. in cc.	Amperes (approx.)	Amp./cm <sup>2</sup> (approx.)	Na <sub>2</sub> S <sub>2</sub> O <sub>3</sub> cc.	Difference.	
							cc.	%
(1)	1.6 × 2.7	2	5 in 7.5	0.5	0.058	130.84	0.17	0.13
	1.6 × 2.7	5	5 " 7.5			130.67		
(2)	1.6 × 2.7	2	5 " 7.5	0.5	0.058	128.49	0.06	0.047
	1.6 × 2.7	5	5 " 8.5			128.55		
(3)	1.6 × 2.7	2	5 " 7.5	0.5	0.058	127.36	0.10	0.078
	2.5 × 6.0	5	10 " 20		0.017	127.46		
(4)	1.6 × 2.7	2	5 " 7.5	0.5	0.058	170.67	0.23	0.135
	1.6 × 2.7	5	5 " 7.5			170.67		
	2.5 × 6.0	5	10 " 20			0.017		

Table III is a record of a number of determinations of the constancy of this voltameter. Two or more of the cells were connected in series, and the conditions in each varied as shown. The time of run for 1 to 3 inclusive was about 45 mins., for the 4th, one hour. The amount of hydrochloric acid (1:4) was not measured. Enough of the acid was drawn in to insure the covering of the cathode when the iodide solution was drawn in, and to keep the solution acid throughout the experi-



ment. The iodide was roughly weighed. No correction was made for the blank determinations, nor was special care taken to maintain exact constancy of temperature.

Table IV shows the results of the only two determinations that were made by three of the iodine voltameters in series with each other and with one normal silver gravimetric voltameter. The original readings of the burettes for the required thiosulphate is given in the 6th column. In the 7th column is given the value corrected for the blank determinations. A number of blank determinations for the small cell, when 5 grams of iodide were used, gave, with the blank shown in (2), an average value of 0.07<sup>cc</sup> of thiosulphate, which is the correction applied to all of the small cells. The large cell, with 10 grams of potassium iodide, showed an average value for a blank determination of 0.21<sup>cc</sup> of thiosulphate. This is three times instead of twice the value of the small cell, as would be expected were the result due to traces of iodate in the iodide. The uncertainty as to the amount of iodine liberated by iodate, or by dissolved oxygen, or by possible oxidizing impurities of the acid, make it rather more desirable to employ known weights of the iodide and known volumes of the acid and then to correct for the blank determination, than the alternative of securing absolute freedom from these extra sources of liberation of iodine.

In the silver voltameter employed, the cathode was a platinum bowl about 8<sup>cm</sup> in diameter and 3.5<sup>cm</sup> in depth. The anode was a silver disc, 5.8<sup>cm</sup> in diameter, 0.8<sup>mm</sup> thick, and supported by three platinum wires bent over its edges. This was wrapped in filter paper. The solution was made up of 20 grams of pure silver nitrate, dissolved in 106<sup>cc</sup> of distilled water. The deposited silver was washed with water and allowed to stand under water over-night. Then washed again with water, finally with absolute alcohol and heated for 4 hrs. in an oven at 160°. Then allowed to cool for an hour in a desiccator before weighing.

TABLE IV.

	Electrodes, cm.	Distance between Electrodes, cm.	KI grms. in cc.	Amp. (approx.)	Amp./cm <sup>2</sup> (approx.)	Na <sub>2</sub> S <sub>2</sub> O <sub>3</sub> cc.	Na <sub>2</sub> S <sub>2</sub> O <sub>3</sub> corrected for blank, cc.	Silver equivalent, grms.	Silver (in vac.) ag-voltameter, grms.	Difference.	
										Grms. of silver.	%
1	1.6 × 2.7	2	5 in 7.5	0.5	0.058	152.07	152.00	1.63386	1.63236	0.00150	0.092
	1.6 × 2.7	5	5 " 8.5		0.058	152.06	151.99	1.63375		0.00139	0.085
	2.5 × 6.0	5	10 " 20		0.017	152.19	151.98	1.63364		0.00128	0.078
2	1.6 × 2.7	2	5 " 7.5	0.5	0.00	0.06			1.67934	0.00106	0.063
	1.6 × 2.7	5	5 " 7.5		0.058	156.40	156.33	1.68042		0.00119	0.071
	2.5 × 6.0	5	10 " 20		0.017	156.55	156.34	1.68053			

The titrations in the experiments recorded in this table were made with due regard to all possible sources of error. The solutions were brought precisely to the temperature of 20°, at which temperature the room was maintained. The burettes had been thoroughly cleaned with chromate solution, and of course, ample time was allowed for the burettes to drain to a constant reading. The results show that the iodine voltameter, even after the correction for the blank determinations, run uniformly higher by from 0.06 per cent to .09 per cent; but that they agree among themselves to an order of accuracy of about 1 part in 10,000.

Sloane Physical Laboratory,  
Yale University, June 5, 1905.

ART. II.—*The Handling of Precipitates for Solution and Reprecipitation*; by F. A. GOOCH.

[Contributions from the Kent Chemical Laboratory of Yale Univ.—cxxxv.]

IN many processes of analytical chemistry, the preparation of substances in pure condition is brought about by precipitation, solution, and reprecipitation; and sometimes this cycle of operations must be repeated. When a precipitate, gathered upon a filter, is easily acted upon by the appropriate solvent, the process of dissolving the precipitate from the filter is simple; but when the precipitate is refractory toward solvents or difficult to attack on account of its physical condition, as is the case with many gelatinous precipitates, the proper handling of the precipitate involves some inconvenience and delay.

In meeting such difficulties, I have found it advantageous to place within the ordinary paper filter, before filtering, a movable lining of platinum gauze upon which the precipitate rests for the most part and with which it may be removed. The simplest form of this device is easily made by cutting platinum gauze to the shape shown in the accompanying figure. In ordinary use, this piece of gauze, folded to make a cone of angle a little less than  $60^\circ$ , and held by pincers at the point of overlapping, is placed within this filter and allowed to fit itself closely by the natural spring of the gauze when released.



Upon filters so prepared a precipitate may be collected and washed as usual; and, at the end of the operation, the cone with nearly all the precipitate may be transferred, by means of ivory-pointed pincers, to dish or beaker for suitable treatment. The small amounts of the precipitate which have passed through the gauze, being somewhat protected by the gauze against the compacting action of filtration and washing, are generally removable with ease from the filter by a jet of the washing-liquid. After washing, the gauze may be replaced within the same filter and serve for a second collection of the precipitate to be subsequently dissolved, in case double precipitation and solution are desirable. The final collection of the precipitate is, of course, made upon paper without the gauze lining, when precipitate and filter are to be ignited.

This device has proved very serviceable in the handling of such precipitates as ferric hydroxide, aluminium hydroxide, and basic acetate precipitations.

I have used also in the manipulation of such precipitates a regularly made cone of  $60^\circ$ , fitted with eyelets for handling; but the simple folded cone is, on the whole, more convenient.

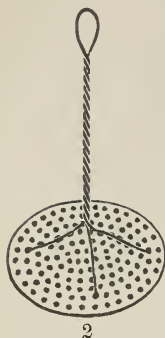

Precipitates collected upon asbestos in the perforated crucible are frequently removable without difficulty by allowing a suitable solvent to percolate precipitate and felt; but in case the precipitate is pasty or compacted, solution in this manner may be unpleasantly slow. In such cases, it is convenient to remove the greater part of the precipitate, collected and washed in the usual manner, upon a disc of platinum foil, perforated, fitted with a wire handle, as shown in the figure and placed upon the asbestos felt before the transfer of the precipitate to the crucible. To make such a disc, shown in figure 2, is the work of a few moments only; and by its use pasty precipitates, such as cuprous sulphocyanide or the sulphides of the metals, are easily handled for solution.

These simple devices so facilitate the manipulation of precipitates in many processes of analysis that they have seemed to be worthy of description.

ART. III.—*The Estimation of Sulphites by Iodine*; by  
R. HARMAN ASHLEY.

[Contributions from the Kent Chemical Laboratory of Yale Univ.—cxxxvi.]

VOLHARD'S method for the determination of sulphur dioxide and sulphites is accurate and reliable, but involves the inconvenience of making up every solution to be examined accurately to a standard volume of which portions are to be drawn from a burette and made to react with definite amounts of a standardized solution of iodine. The method consists in running the unknown sulphite or sulphurous acid solution into a known amount of a standardized solution of iodine, acidified with hydrochloric acid, to the disappearance of the iodine reaction with starch. This procedure rests upon the facts that the oxidation of sulphite is brought about in the acidified solution and that, as Bunsen showed, no more than a small proportion of hydriodic acid should be present at the point at which the bodies are made to react. The reaction for the oxidation of sulphur dioxide proceeds normally in dilute solutions according to the equation

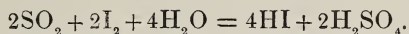

In solutions too concentrated, however, the secondary reaction

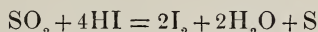

takes place as Volhard has shown\*, and vitiates the indications.

To avoid the inconvenience of the Volhard method it has been proposed by Rupp† to bring about the oxidation of sulphites by treatment with an excess of standardized iodine in a solution made alkaline by acid sodium carbonate, and then, after fifteen minutes, to titrate the excess of iodine by sodium thiosulphate. This procedure, however, is, as has been shown by Ruff and Jaroch‡ and by the present writer,§ faulty in principle and practice, and gives correct results only by a chance balancing of opposing errors. Theoretically it might be possible to overcome the difficulties by treating with acid the alkaline mixture of iodine and sulphite and acid sodium carbonate

\* Ann. Chem. 242, 93.

† Ber. Dtsch. Chem. Ges. xxxv, 3694.

‡ Ber. Dtsch. Chem. Ges. xxxviii, 409.

§ This Journal, vol. xiv, p. 237.

before attempting to titrate by sodium thiosulphate the excess of iodine.

In the experiments recorded in the table the following procedure was followed: the sulphite was treated with 1 gram. of acid sodium carbonate and an excess of standardized iodine solution. The solution was then acidulated with a safe amount of hydrochloric acid, it having been found by experiment that the presence of 10<sup>cm</sup><sup>3</sup> of 1:4 hydrochloric acid in 125<sup>cm</sup><sup>3</sup> of water was without effect upon the determination of iodine by sodium thiosulphate. The excess of iodine after acidification was titrated by standardized sodium thiosulphate. It will be noticed that in the experiments recorded under A of the table, the excess of iodine used was small and in these experiments large negative errors are obtained; while in the experiments recorded under B, in which a large excess of iodine was employed, the results are better. They are best when at least twice as much iodine is added as is theoretically required to oxidize the sulphur dioxide. The length of time during which the iodine may act does not affect the results to any very marked degree.

## A

Iodine value of SO <sub>2</sub> taken. gm.	Iodine taken. gm.	Iodine value of Na <sub>2</sub> S <sub>2</sub> O <sub>3</sub> used. gm.	Error.		Excess of HCl 1:4. cm <sup>3</sup> .	Vol. at titration. cm <sup>3</sup> .
			In terms of Iodine. gm.	In terms of SO <sub>2</sub> . gm.		
0·2197	0·3143	0·0978	-0·0032	-0·0008	7·5	125
"	"	0·0965	-0·0019	-0·0005	"	"
"	"	0·0970	-0·0024	-0·0006	"	"
0·1535	0·1913	0·0464	-0·0086	-0·0022	"	"
"	"	0·0467	-0·0089	-0·0022	"	"
"	"	0·0472	-0·0094	-0·0024	"	"
"	"	0·0465	-0·0087	-0·0022	"	"
0·2366	0·3194	0·0903	-0·0075	-0·0019	"	"
0·2906	0·3825	0·1132	-0·0213	-0·0054	"	"
0·3825	0·4463	0·0750	-0·0112	-0·0028	"	"

## B

0·1143	0·3143	0·1990	+0·0010	+0·0003	5·0	125
"	"	0·1982	+0·0018	+0·0004	"	"
"	"	0·1992	+0·0008	+0·0002	"	"
"	"	0·1986	+0·0014	+0·0003	"	"
0·1482	0·3187	0·1708	-0·0003	-0·0001	7·5	"
0·1576	0·3187	0·1586	+0·0025	+0·0006	"	"
"	"	0·1643	-0·0032	-0·0008	"	"
"	"	0·1598	+0·0013	+0·0003	"	"
"	"	0·1606	+0·0005	+0·0001	"	"
"	"	0·1602	+0·0009	+0·0002	"	"

(B)

Iodine value of SO <sub>2</sub> taken. gm.	Iodine taken. gm.	Iodine value of Na <sub>2</sub> S <sub>2</sub> O <sub>3</sub> used. gm.	Error.		Excess of HCl 1 : 4 cm <sup>3</sup> .	Vol at titration. cm <sup>3</sup> .
			In terms of Iodine. gm.	In terms of SO <sub>2</sub> . gm.		
0·1576	0·3187	0·1622	-0·0011	-0·0003	7·5	125
0·1560	0·3195	0·1660	-0·0025	-0·0006	"	"
0·1992	0·4460	0·2482	-0·0014	-0·0003	"	"
0·1915	0·3825	0·1919	+0·0009	-0·0002	"	"
0·2056	0·3771	0·1701	+0·0014	+0·0003	"	"
"	"	0·1697	+0·0018	+0·0004	"	"
"	"	0·1707	+0·0008	+0·0002	"	"
"	"	0·1709	+0·0006	+0·0002	"	"
[0·2131	0·4470	0·2412	-0·0073	-0·0018]	"	"
0·2354	0·3825	0·1490	-0·0019	-0·0005	"	"
0·2597	0·4463	0·1869	-0·0003	-0·0001	"	"
0·2638	0·4463	0·1847	-0·0022	-0·0005	"	"
0·2908	0·6375	0·3505	-0·0038	-0·0009	"	"
0·3187	0·4463	0·1326	+0·0050	+0·0012	"	"
0·3395	0·6275	0·2842	+0·0038	+0·0009	"	"
"	"	0·2852	+0·0028	+0·0007	"	"
"	"	0·2844	+0·0036	+0·0009	"	"
"	"	0·2855	+0·0025	+0·0006	"	"

Ruff and Jaroch\* take the ground that in the favorable results occasionally obtained by Rupp's process, an error due to the over-oxidation of the tetrathionate normally formed in the action of sodium thiosulphate upon the residual iodine is apparently balanced by some oxidation of sulphur dioxide by dissolved air, the iodine in solution acting catalytically as well as directly. The theory, however, is quite at variance with the evidence supplied in the table: for, if it were true, under no conditions could iodine in the presence of air act as a correct measure of sulphur dioxide, as it apparently does when used in a sufficiently large excess; nor does the theory of the catalytic action of iodine explain the fact that when a greater mass of iodine is used, under conditions otherwise similar, we get a larger oxidation of sulphur dioxide.

The most obvious explanation is that at a low concentration of iodine an intermediate oxidation product may be formed and that the formation of this product may be prevented by sufficient concentration of the iodine. It is not unreasonable to suppose that the formation of a small amount of dithionate instead of sulphate is the occasion of the deficient expenditure of iodine noted when the concentration of this element is low, and that the dithionate is not formed appreciably when the

\* Loc. cit.

iodine concentration is high. The dithionate once formed is but slowly attacked by iodine, and that is apparently the reason why long standing of the mixtures containing a small proportion of iodine does not result in complete oxidation of the sulphite to sulphate. From these considerations it will be seen that the secondary error of Rupp's process may very probably be due to the formation of some dithionate from the sulphite where the concentration of the iodine is low.

The practical estimation of sulphurous acid or a soluble sulphite may, then, be accomplished with a reasonable degree of accuracy by adding to the solution of the substance, not exceeding 100<sup>cm</sup><sup>3</sup> in volume and containing a gram of acid sodium carbonate, at least twice as much iodine as is theoretically necessary to effect oxidation, acidifying cautiously with hydrochloric acid, and determining with standard sodium thiosulphate the excess of iodine remaining in the acidified solution.

The author takes this occasion to thank Prof. F. A. Gooch for much kind assistance.



ART. IV. — *Revision of the New York Helderbergian Crinoids*;\* by MIGNON TALBOT. (With Plates I–IV.)

THIS paper treats of the Crinoidea of the Helderbergian rocks of New York, and is a continuation of Dr. George H. Girty's thesis, "A Revision of the Sponges and Coelenterates of the Lower Helderberg Group of New York." In Dr. Girty's paper, the term "Lower Helderberg" included the Tentaculite, or Manlius, limestone; but here "Helderbergian," as proposed by Clarke and Schuchert,† is used to include only the Coeymans, or Lower Pentamerus; the New Scotland, or Delthyris Shaly; and the Becraft, or Upper Pentamerus.

With the exception of the work done by Wachsmuth and Springer, who probably used specimens that Hall had studied, the crinoids of the Helderbergian rocks of New York have not received much attention since Hall's descriptions were published, in 1859. Very little subsequent collecting has been done, and for the most part the forms secured have been specimens of *Homocrinus scoparius* and *Edriocrinus pocilliformis* or simply stem fragments, the work of gathering being done in the New Scotland.

A reopening of the old locality at Jerusalem Hill was made, however, in 1901, by Professors Beecher and Schuchert; and a new locality was discovered at North Litchfield, both of these being in the Coeymans limestone. The majority of fossils found were crinoids, but there were also cystids in appreciable numbers and five ophiuroids representing two genera. In the fall of 1903, these collections were increased by more material collected at the same locality by Mr. C. J. Sarle; so that in the Yale University Museum there are now three collections—one from Jerusalem Hill and two from North Litchfield.

The first of these consists mainly of *Homocrinus scoparius*, though it contains uncompressed forms of *Cordylocrinus plumosus* and several good specimens of *Melocrinus pachyductylus*. In the region of Litchfield, the Coeymans limestone attains a thickness of one hundred and fifty feet and *Homo-*

\* This paper is part of a thesis presented to the Graduate Faculty of Yale University for the degree of Doctor of Philosophy, in June, 1904. The larger part of the work was done under the supervision of the late Professor Charles Emerson Beecher, for whose help and inspiration the writer wishes to make the most grateful acknowledgment. Type specimens have been studied in the Yale University Museum, the New York State Museum and the American Museum of Natural History: and the thanks of the writer are here expressed to Professor R. P. Whitfield, Dr. J. M. Clarke, Dr. E. O. Hovey and Mr. H. H. Hindshaw, for courtesies in connection with the study, and to Professor Charles Schuchert, who took up the direction of the work after Professor Beecher's death.

† Science, New Series, vol. x, p. 876, 1899.

*crinus scoparius* is said to range from the Manlius almost to the top of the Coeymans. Most of the specimens in the Yale collection were found about forty-six feet from the top of the section in a twelve-inch layer containing slabs rich in *Homocrinus scoparius* and also specimens of *Melocrinus pachydactylus*, *Anomalocystites cornutus*, *Lepocrinites gebhardi* and the ophiuroids. *Cordylocrinus plumosus* is abundant in the lower bed mentioned later.

The collection from North Litchfield is chiefly from two horizons and is extremely rich. One of these beds is a limestone four inches thick in which are specimens of *Melocrinus nobilissimus* with very large crowns and very stout, long stems and a large form of *Cordylocrinus plumosus* in comparative abundance, the majority of the individuals showing many long cirri crowding around the calyx. The material from this zone has one specimen of *Lepocrinites gebhardi* and several of *Homocrinus scoparius*. Although all the fossils in this bed are of large size, especially is this true of *Melocrinus nobilissimus*, whose columns are very thick and, though only fragments, measure from fifty to seventy centimeters in length. This is long for Paleozoic crinoids. Wachsmuth and Springer state that no columns over three feet in length have been seen from the Paleozoic and that generally they are not over one foot long.\* Here there are numbers over two feet in length.

The other horizon, a few inches higher in the section, has furnished slabs covering a floor space of some sixty-five square feet, slabs that are literally covered with crinoid stems and crowns. Here, too, as in the lower bed, are stems over two feet long. The forms represented are *Mariacrinus beecheri*, *Melocrinus nobilissimus*, *M. pachydactylus*, *Thysanocrinus arborescens* and *Cordylocrinus plumosus*. To show the relative abundance of these species, an enumeration of the individuals on the slabs was taken and by actual count there were found, of *Mariacrinus beecheri* thirty-one specimens, of *Melocrinus nobilissimus* six, of *M. pachydactylus* one, of *Thysanocrinus arborescens* ten, and of *Cordylocrinus plumosus* eight hundred and seventy-three, making a total of nine hundred and twenty-one specimens. In addition to these are numerous crinoid columns, several gastropods and brachiopods and one cephalopod. On a small surface of six square feet there are three hundred and twenty crinoids.

The cover of this bed is also in the collection and it is estimated that two-thirds as many more crinoids are on its lower surface. This enumeration was made before anything was done toward developing the slabs and such preparation may

\*North American Crinoidea Camerata, vol. i, p. 39; Mem. Mus. Comp. Zool., Harvard College, vol. xx, Cambridge, Mass., May, 1897.

double the number now visible; hence in this one collection, there are undoubtedly more crinoids than in all other collections from New York combined.

The following species, listed by Hall from the Coeymans limestone at North Litchfield, have not been recognized in the Yale material: *Mariacrinus paucidactylus* (probably *Melocrinus pachydactylus*), *M. ramosus*, *M. plumosus*, *Platycrinus parvus* (probably *Cordylocrinus plumosus*), *P. ramulosus* (seems to be restricted to the Cobleskill zone of the Manlius) and *P. tentaculatus*. This is not to be wondered at, however, as a slight change of position, horizontally or vertically, often reveals a different fauna; and as Hall's collections represented gatherings not only from the quarries but also from the stone walls about the town of Litchfield, the fossils undoubtedly came from different horizons and localities.

In the classification, nomenclature and terminology of the crinoids, Wachsmuth and Springer have been followed and the reader is referred to their works, "The North American Crinoidea Camerata"\* and "The Revision of the Palæocrinoidea."†

Order, INADUNATA Wachsmuth and Springer.

Suborder, FISTULATA, Wachsmuth and Springer.

Family, *Cyathocrinidae* Roemer.

Genus, *Homocrinus* Hall.

*Homocrinus scoparius* Hall. Plate III, figure 3.

*Homocrinus scoparius* Hall, Nat. Hist. N. Y., Pal., vol. iii, 1859, p. 102, pl. 1, figs. 1-9.—Wachsmuth and Springer, Rev. Palæoc., Pt. I, 1879, p. 79; Proc. Phila. Acad. Nat. Sci., vol. xxxi, 1880, p. 302.—Bather, Kongl. Svenska Vet. Akad., Handl. xxv, 1893, p. 105.

In the collection of crinoids from Jerusalem Hill, N. Y., now in the Yale University Museum, there is a considerable number of slabs showing *Homocrinus scoparius* in abundance. These slabs vary in size from a few centimeters to over half a meter in length and the surfaces are virtually covered with these beautiful fossils. One slab, thirty centimeters long and twenty-three wide, has eighteen specimens, three of which are complete, that is, have the crown and the whole length of the column, including the distal end. Aside from these, there are four other stems and two (possibly three) specimens of *Anomalocystites cornutus* on the same slab. On other slabs from the same horizon are *Melocrinus pachydactylus*, *Anomalocystites cornutus*, *Protaster forbesi*, and *Dalmanites* sp. (?). Many

\* Memoirs of the Museum of Comparative Zoology at Harvard College, vols. xx and xxi, with Atlas, Cambridge, Massachusetts, May, 1897.

† Proceedings of the Philadelphia Academy of Natural Sciences, vols. xxxi, xxxiii, xxxvii and xxxviii.

of the specimens of *Homocrinus* are in almost perfect condition, and where the fine cirri are visible on the stem the grace and delicacy of this species are well shown (pl. III, fig. 3).

The following additions are made to Hall's description:—

Ventral sac strong, elongated, sometimes three-fourths as long as the arms, the upper part composed of vertical rows of small hexagonal plates. The upper end of the sac probably has five large plates, which are drawn out into spines, something like those in *Scaphocrinus unicus*. Three of these spines and traces of a fourth can be seen in one specimen, and their position shows that a fifth was probably present originally. These spines are not scattered irregularly over the upper surface, as is indicated in Hall's figure. Column long and slender, consisting of irregularly alternating larger and smaller joints, round below and becoming obtusely angular and enlarged above. Canal small and round. Shortest column observed 4<sup>cm</sup> in length; longest, which is still incomplete, 15<sup>cm</sup> long. Very delicate cirri are preserved, but in no specimen are they found above the middle of the stem. Wherever the distal end of the column is present, there is a coil or loop, as if the stem twined around some support (pl. III, fig. 3). No indications of the clustering of columns mentioned by Hall were seen in the Yale collection.

*Horizon and locality.*—Common in the thinly laminated or shaly layers of the Coeymans or Lower Pentamerus, at Schoharie, Jerusalem Hill and North Litchfield. Hall reports the species from the Manlius, or Tentaculite, limestone,\* but no such specimens have come under the writer's observation.

*Cotypes* (used by Wachsmuth and Springer for the revised genus) in the American Museum of Natural History, from Litchfield, N. Y.

#### Family, *Edriocrinidae* n. fam.

In the specimens of *Edriocrinus* under observation, there are differences that at first seemed to have specific, if not generic value. There are two quite common forms—one (No. 1 and No. 2)† the small hemispherical cups, so well known to collectors in the Helderberg Mountains; and another (No. 3) like the preceding only that the cup has a prominent band or ring around the upper margin. There are other forms that are not so common, however; and they can be divided into two groups, or even three. One specimen (No. 4) about twice as high as the common ones has the hemispherical cup, above which and fused to which is a solid band; and above this still another band of six fused plates, twice as high as the lower

\* Nat. Hist. N. Y., Pal., vol. iii, p. 103, 1859.

† Numbers refer to those on pl. IV, figs. 1-6.

band. Another individual (No. 5) does not show the first band, and the second is broken up by weathering into five comparatively broad plates and one narrow one. The next specimen to attract attention (No. 6) resembles the one just described only that on one side the plates succeeding the cup have the appearance of a row of three short plates, instead of one high one.

It was not until these forms, seemingly so different, had been most carefully compared that any conclusion concerning them could be reached. The difficulty was due, mainly, to the fact that in most cases the suture lines are wholly obliterated; but, with a trace of a suture here and another there, there was something on which to base an interpretation. The following solution is offered:

The genus *Agassizocrinus* is said to be dicyclic because young specimens have infrabasals, although the latter are obliterated before maturity is attained. The question has arisen, Why may not the same be true of *Edriocrinus*? By following out this idea, these seemingly distinct forms were reduced to two whose difference is simply in the development of the basals, which in one group are inconspicuous and in the other are enlarged to form the prominent ring or band mentioned above.

The explanation of these varying specimens is as follows: No. 2 and No. 5, instead of being monocyclic, are dicyclic, the infrabasals, which are the largest, being fused with the basals. No. 3 shows infrabasals and basals, the latter being very prominently developed. No. 6 has infrabasals and fractured radials, but no brachials. This conclusion has been reached by comparing opposite sides of the same specimen. Though on one side there seems to be a short radial followed by two short brachials in each ray, the other side shows no such division; and it is evident that the apparent brachials are due to the transverse breaking of the radials. This view is supported by the fact that the anal plate is as high as the radials and the apparent brachials combined. No. 4 shows all the plates of the calyx and furnishes the clue to the others. The prominence of the basals is hardly a specific characteristic and these specimens are all left in the original species, *E. pocilliformis*. In the Yale collection, there is one example of *E. sacculus* which gives faint indications of the presence of infrabasals, though none of the specimens show any thickening of the basal ring.

In regard to classification, these forms certainly cannot belong with the genus *Agassizocrinus* in the family Astylocrinidæ, where *Edriocrinus* was placed provisionally by Wachs-

muth and Springer,\* because there are no supplementary anal plates in the calyx, as is the case in *Agassizocrinus*. Bather lists the genus provisionally under the order *Flexibilia*,† an order with no anal plate in the cup; but, as *Edriocrinus* has such a plate, the genus cannot be so referred. The calyx structure is that of the Cyathocrinidæ but there are differences that prevent the reference of *Edriocrinus* to this family. The absence of a column is one of these differences and the manner in which the rays divide is another. In *Cyathocrinus*, which is the most representative genus of the family, the arms in branching spread out irregularly, and the joints are generally higher than wide; while in *Edriocrinus* the joints are very short, and the arms branch as do those of *Ichthyocrinus*, the divisions remaining in contact and curling inward. The arms, however, do not form a part of the calyx as in the last named genus.

*Family description*.—Calyx elongate. Base dicyclic, probably five fused plates in each order. Radials with facets for the insertion of the brachials extending across the whole width. Arms incurved, seemingly without pinnules, divisions remaining in contact; joints much wider than long. Column wanting, the attachment being by the infrabasals in the young stages; mature forms unattached.

#### Genus, *Edriocrinus* Hall.

##### *Edriocrinus* Hall.

*Edriocrinus* Hall, Nat. Hist. N. Y., Pal., vol. iii, 1859, p. 119; 15th Rept. N. Y. St. Cab. Nat. Hist., 1862, p. 115.—Meek and Worthen, Geol. Rept. Ill., vol. iii, 1868, p. 119.—Wachsmuth and Springer, Rev. Palæocr., Pt. I, 1879, p. 21, Pt. III, 1885, p. 10, and 1886, pp. 192, 265, 286; Proc. Phila. Acad. Nat. Sci., vol. xxxi, 1880, p. 244, vol. xxxvii, 1886, p. 232, and vol. xxxviii, 1887, pp. 116, 189, 210; N. Am. Cri. Cam., vol. i, 1897, pp. 59 and 145.—Zittel, Handb. d. Palæontol., I Band, 1880, p. 350.—P. H. Carpenter, Ann. Mag. Nat. Hist., May, 1883, p. 333.—Bather, Rept. Brit. Assoc. Adv. Sci. for 1898, p. 923; A Treatise on Zoology, 1900, Pt. III. The Echinoderma, p. 191.

*Amended generic description*.—Calyx directly cemented, either throughout life or only in the young stages, the attachment being by the large infrabasals. The cicatrix very large in some specimens and in others obliterated, by the accumulation of calcareous matter on the outer surface of the calyx plates. Infrabasals large, their height being from one-half to two-thirds that of the cup as ordinarily found, completely fused so as to destroy suture lines and to make the number of plates uncertain. Basals five, height varying in proportion to that of

\* Rev. Palæocr., Pt. III, p. 192, 1885, or Proc. Phila. Acad. Nat. Sci., vol. xxxviii, p. 116.

† Rept. Brit. Assoc. Adv. Sci. for 1898, p. 923; also The Echinoderma, p. 191, 1900.

the infrabasals, generally so fused as to show no suture lines on the outer surface, although they are often seen on the inner side. Upper margin scalloped for the attachment of the radials and the anal plate. Radials five, large, rectangular, the upper margin excavated slightly for the attachment of the brachials and the lower curved to fit into the concave upper margin of the basals. An anal plate half as wide as the radials and a small plate above it furnish all that is known of the anal area. Ventral surface unknown. Arms known in only one species, *E. sacculus*, where they consist of very short transverse plates and bifurcate several times, but show no trace of pinnules.

*Genotype, E. pocilliformis* Hall.

*Edriocrinus pocilliformis* Hall. Plate IV, figures 1-6.

*Edriocrinus pocilliformis* Hall, Nat. Hist. N. Y., Pal., vol. iii, 1859, p. 121, pl. v, figs. 8-12.—Meek and Worthen, Geol. Rept. Ill., vol. iii, 1868, p. 370, pl. 7, figs. 5a and 5b.—Wachsmuth and Springer, Rev. Palæocr., Pt. III, 1886, p. 266; Proc. Phila. Acad. Nat. Sci., vol. xxxviii, 1887, p. 190.—Keyes, Geol. Surv. Mo., vol. iv, 1894, p. 221, pl. xxx, fig. 7.

*Amended specific description.*—Infrabasals present but so fused that their number is uncertain. Height from one-half to two-thirds that of the cup as ordinarily found. Basals five, completely fused with each other and with the infrabasals or distinguished from the latter as a narrow protruding band. Suture lines sometimes apparent on the interior. Upper margin scalloped for the attachment of the radials and the anal plate. Height about half that of the infrabasals. Radials five, often as high as the infrabasals and basals combined, and, like them, fused to form a part of the cup. In most instances, however, the suture lines between the radials are plainly discernible. As a rule, the union between the radials and basals is not so strong as that of basals with infrabasals; and the cup is generally broken off at the top of the basals. Since in no specimens are brachials preserved, the union of brachials with radials must have been still weaker. Anal plate as high as the radials, but only half as wide. Radials and anal gently convex, sloping in all directions from the center of the plate. Arms and ventral disk unknown. The attachment scar is visible on a number of specimens, and in some is a short distance up on the side of the cup, rather than on the bottom.

*Horizon and locality.*—Throughout the New Scotland limestone in Helderberg Mountains.

*Cotypes* in the American Museum of Natural History.

Order, CAMERATA Wachsmuth and Springer.

Family, *Thysanocrinidæ* Wachsmuth and Springer.

Genus, *Thysanocrinus* Hall.

*Thysanocrinus arborescens* n. sp. Plate I, figure 2; text-figure 1.

Although, in America, no members of this genus have been reported above the Niagara, a number of crinoids that must

be referred to this genus is found in one of the beds of the Coeymans limestone at North Litchfield. The generic features, as given by Wachsmuth and Springer,\* are well marked—the subglobose calyx, urn or bell-shaped; infrabasals five, small, barely protruding beyond the column; basals five, the posterior one truncated by a large anal plate; radials five, considerably larger than the costals; costals two; arms ten or twenty, rather strong and biserial; pinnules long; first interbrachial large, followed by smaller ones; anal side wider, first anal plate followed by three in the next row.

The specimens under examination lack the ridges which are so conspicuous in marking the rays in most of the species of *Thysanocrinus*; their plates are smooth, instead of being sculptured as is generally the case in this genus, and the column is pentangular, while in most of the species it is round. The specimens resemble *T. liliiformis* more closely than any other species, but differ from it in the pentangular column and the absence of the ridges on the radial series of plates. Not enough is known about the bifurcation of the arms in *T. liliiformis* to make comparison.



Text-figure 1.—Diagram of *Thysanocrinus arborescens* showing position of the anal plates and first bifurcation of the arms.

bifurcation occurs, seemingly only on the inner branches and at different intervals in the different arms, varying from the fourteenth to the twenty-third palmar. Pinnules found on the fifth distichal and continuing to the tips of the arms. Column pentagonal. Near the calyx, the joints alternate in size; but farther down the stem every fourth joint is larger. In a specimen in which the crown is 29<sup>mm</sup> in length, the column, though incomplete, is 40<sup>cm</sup> long.

\* N. Am. Cri. Cam., vol. i, p. 190, 1897.



This species is associated with *Melocrinus nobilissimus*, *M. pachydactylus*, *Mariacrinus beecheri*, and *Cordylocrinus plumosus*.

*Horizon and locality*.—Upper third of the Coeymans limestone at North Litchfield.

*Holotype* in the Yale University Museum.

Family, *Melocrinidae* Roemer.

Subfamily, *Melocrininae*.

Genus, *Mariacrinus* Hall.

In re-diagnosing the genera *Mariacrinus* and *Melocrinus*, Wachsmuth and Springer recognized the fact that the arms of the former remain apart and do not form the tubular appendage which is so conspicuous in *Melocrinus*. The only species in the Yale collection that shows this characteristic of *Mariacrinus* is a new species, *M. beecheri*, in which the proximal end of the ray forms a tube while the distal end is divided, the arms diverging conspicuously. The species is thus seen to hold a position intermediate between *Mariacrinus* and *Melocrinus*. As the features of the former are more strongly developed, this species is referred to that genus.

Genotype, *M. plumosus* Hall.

*Mariacrinus beecheri* n. sp. Plate I, figure 3; text-figure 2.

This species bears a resemblance to *Melocrinus nobilissimus* but differs from it in features other than the division of the rays. The auxiliary arm, instead of being comparatively inconspicuous, as in *Melocrinus*, is strong and prominent and lies alongside the tube.

The joints of the rays are longer than those of *M. nobilissimus*, so that, although the arms are given off more frequently than in the last named species, they seem to take origin at greater intervals. As in *M. nobilissimus*, the stem joints alternate in size, but they are so very thin in all parts of the stem, and especially so near the crown, that there is no difficulty in determining this form by the column alone. The column is also much larger in proportion to the size of the calyx.

*Specific description*.—Calyx small, elongate, once and a half as long as wide, the increase in width being very gradual. Basals wider than long, pentagonal, not forming a projecting cup, but continuing the width of the column. Radials five, four heptagonal and one hexagonal. Costals two, the first hexagonal, more than half as large as the radials, and the second smaller, pentagonal, and support-



Text-figure 2.—Anal sac of *Melocrinus beecheri* with *a*, *b* and *c* as the last of the anal series of plates in the cup.  $\times 4\frac{1}{2}$ .

ing two rows of distichals, three in each row. The last distichal supports two rows of palmars, whose first two plates are connected. Above this point, the palmars separate, those on the outside of the ray forming an auxiliary arm which lies alongside the ray but is not connected with it. The inner row of palmars joins corresponding plates from the other row of distichals to form a tubular appendage which extends for a short distance only, when the divisions separate and remain apart to the end of the ray. On the outer side of the ray, arms arise from every fourth or fifth joint; but, on account of the length of the joints, the arms are quite far apart. The arms are biserial to the end. The first interbrachial is large, hexagonal, followed by a double row of alternating hexagonal plates. Anal interradius wider and ending in a short thick tube or sac, composed of numerous plates which seem to have been hexagonal originally. This sac is seen in but one specimen, where the plates are very poorly preserved (text-fig. 2). Column circular, with diameter large in proportion to the size of the calyx. Distally the joints alternate in size, but near the calyx they are very thin and of uniform thickness.

*Horizon and locality.*—Upper third of the Coeymans limestone at North Litchfield.

*Cotypes* in the Yale University Museum.

Genus, *Melocrinus* Goldfuss.

Genotype, *Mariacrinus nobilissimus* Hall.

*Melocrinus nobilissimus* (Hall). Plate II.

*Mariacrinus nobilissimus* Hall, Nat. Hist. N. Y., Pal., vol. iii, 1859, p. 105, pl. 2, figs. 1-5; pl. 2A, fig. 1.

*Melocrinus nobilissimus* Wachsmuth and Springer, Rev. Palaeocr., Pt. II, 1881, p. 122; Proc. Phila. Acad. Nat. Sci., vol. xxxiii, 1882, p. 296; N. Am. Cri. Cam., vol. i, 1897, p. 295; Atlas, pl. xxiii, figs. la, 2 and 3.—Bather, A Treatise on Zoology, 1900, Pt. III. The Echinoderma, p. 161, text-fig. lxxiv, 2.

Sixteen individuals of this species have been added recently to the Yale collections; yet, since the type specimen is so nearly perfect, very little additional knowledge has been gained from this new material. Attention, however, may be called to a few points. One specimen shows a row of three or four small plates between the auxiliary arm and the tubular appendage. These plates appear in the figures given by Wachsmuth and Springer, but no mention is made of them in the descriptions. They seem to be interpalmars, though it is possible that they belong to the ventral disk. The domelike extension of the anal series of plates, which is also figured by Hall, is seen indistinctly in one specimen. One crown has a column attached, over 21<sup>cm</sup> in length; while another column on the same slab, and to all appearances of the same species, is over 69<sup>cm</sup> long and gives no indication of proximity to either calyx or distal end.

At North Litchfield, this species was found associated with *Mariaocrinus becheri*, *Melocrinus pachydaetylus*, *Cordylocrinus plumosus*, *Thysanocrinus arborescens*, *Homocrinus scoparius*, *Lepocrinites gebhardi*, and *Dalmanites* sp. The crowns are not numerous, but judging from the associated fragments of stems this spot must have been very favorable to the growth of *Melocrinus nobilissimus*. On one slab about fourteen inches long (pl. II), four crowns were found with columns belonging to forty-six more. The only other fossils on this slab are one *Conularia* and two Bryozoan fragments.

*Horizon and locality*.—Coeymans limestone at Litchfield and North Litchfield.

*Cotypes* in the American Museum of Natural History.

*Melocrinus pachydaetylus* (Conrad). Plate I, figure 1.

*Astrocrinites pachydaetylus* Conrad, Ann. Rept. Pal. N. Y., 1841, p. 34.—Mather, Geol. Rept. N. Y., 1843, p. 347; text-fig. 6 on p. 345.

*Mariaocrinus pachydaetylus* Hall, Nat. Hist. N. Y., Pal., vol. iii, 1859, p. 107, pl. 3, figs. 1-4.

*Mariaocrinus paucidaetylus* Hall, *ibid.*, p. 109, pl. 3, fig. 5.

*Melocrinus pachydaetylus* Wachsmuth and Springer, Rev. Palæocr., Pt. II, 1881, p. 122; Proc. Phila. Acad. Nat. Sci., vol. xxxiii, 1882, p. 296; N. A. Cri. Cam., vol. i, 1897, p. 296, pl. xxiii, figs. 4 and 5; pl. xxiv, figs. 4a and 4b.

*Melocrinus paucidaetylus* Wachsmuth and Springer, Rev. Palæocr., Pt. II, 1881, p. 122; Proc. Phila. Acad. Nat. Sci., vol. xxxiii, 1882, p. 296; N. A. Cri. Cam., vol. i, 1897, p. 296.

*Actinocrinus polydaetylus* Bonny, Schenectady Reflector, 1835.

Although this species heretofore has been considered a rare fossil, it is now represented in the Yale University Museum by thirteen specimens. Little additional knowledge of the calyx, however, has been gained. In all cases where the distichals can be distinguished from the other plates, their number is two, instead of three. The former number agrees with all previous figures; yet, in their description, Wachsmuth and Springer make the distichals three in number.\*

One of the rays, though incomplete, shows nineteen arms, which are plainly seen to be uniserial, not biserial as previously described and figured.† The actinal side of the rays and arms shows the ambulacral groove. As to the number of brachials in the successive orders of the plates of the rays, careful examination of the specimens at Yale yields results different from those reached by Wachsmuth and Springer.‡ Brachials of the fourth, fifth and sixth orders have seven plates, and the subsequent orders seem to alternate with six and seven to the

\* N. Am. Cri. Cam., vol. i, p. 296, 1897.

† Nat. Hist. N. Y., Pal., vol. iii, 1859, p. 108, pl. 3, figs. 1-3 and 4a; N. Am. Cri. Cam., Atlas, pl. xxiii, figs. 4 and 5; pl. xxiv, figs. 4a and 4b, 1897.

‡ *Ibid.*, vol. i, p. 297.

end of the ray. In one specimen, small dome-like interpalms show between the auxiliary arm and the tubular appendage, occupying the same position as in *M. nobilissimus*, but differing in form. Stem joints alternate in size near the calyx, but farther down the column every fourth one is larger. One individual has a stem 19<sup>cm</sup> long, which makes a loop at the distal end about 2·5<sup>cm</sup> in diameter. Another loop not more than 1<sup>cm</sup> in diameter has two complete whorls.

*M. pachydactylus* is found at Jerusalem Hill with *Lepocrinites gebhardi* and many specimens of *Homocrinus scoparius*; at North Litchfield with *Mariacrinus beecheri*, *Melocrinus nobilissimus*, *Thysanocrinus arborescens*, and *Cordylocrinus plumosus*.

Wachsmuth and Springer regard *M. paucidactylus* and *M. pachydactylus* as synonyms, but give no reasons therefor. Hall's distinctions are the narrower calyx and the fewer and more distant arms of the former. The specimen figured on pl. I, fig. 1, is very narrow, proving the width of the calyx to be variable. The greater distance between the branches of the arms cannot, in itself, be considered a specific difference; and there seems to be no reason for referring these narrow specimens to another species.

*Horizon and locality*.—Near the base of the Coeymans limestone at Schoharie;\* in the upper third of the same limestone at Jerusalem Hill and North Litchfield.

#### Family, *Platycrinidæ*.

##### Genus, *Cordylocrinus* Angelin.

*Cordylocrinus plumosus* (Hall). Plate III, figures 2 and 4; text-figure 3.

*Platycrinus plumosus* Hall, Nat. Hist. N. Y., Pal., vol. iii, 1859, pp. 113 and 148, pl. 4, figs. 1-5.

*Platycrinus parvus* Hall, Nat. Hist. N. Y., Pal., vol. iii, 1859, p. 114, pl. 4, figs. 6-9.

*Cordylocrinus plumosus* Wachsmuth and Springer, Rev. Palaeocr., Pt. II, 1881, p. 61; Proc. Phila. Acad. Nat. Sci., vol. xxxiii, 1882, p. 235; N. Am. Cri. Cam., vol. ii, 1897, p. 737; Atlas, pl. lxxv, fig. 20.

*Cordylocrinus parvus* Wachsmuth and Springer, Rev. Palaeocr., Pt. II, 1881, p. 60; Proc. Phila. Acad. Nat. Sci., vol. xxxiii, 1882, p. 234; N. Am. Cri. Cam., vol. ii, 1897, p. 737.

*Clematocrinus plumosus* Jaekel, Zeit. d. deutsch. Geol. Gesell., Band xlix, 1897, Verhandl., p. 47.

*Clematocrinus parvus* Jaekel, Zeit. d. deutsch. Geol. Gesell., Band xlix, 1897, Verhandl., p. 737.

In the Yale Museum, there are many hundreds of specimens of this species; and at first glance it seemed that substantial additions could be made to the descriptions already given. Closer examination, however, revealed the fact that in only a

\* Nat. Hist. N. Y., Pal., vol. iii, p. 109, 1859.

few specimens could the plates be distinguished. It also seemed that there were two species, the fossils differing so much in size, gibbosity and general appearance; but further study failed to reveal any real differences. Some of the forms have a hemispherical calyx, and arms only three or four times as long as the cup, while others have a flat cup and arms five or six times as long; and yet the plates of the calyx, the joints of the arms, the pinnules and the cirri seem to be the same in the two varieties.

In the material from North Litchfield, the lower bed has much the larger forms, all of which are compressed. The upper bed has an abundance of the smaller ones, a few of which have the calyx gibbous, not flattened. The specimens from Jerusalem Hill are uncompressed and small. Wachsmuth and Springer consider *C. parvus* the young of *C. plumosus*; and it may be that it was these small, uncompressed specimens from the upper crinoid bed that Hall had under observation when he described the former species. If this assumption can be proved, it may be well to regard *C. parvus* as a variety of *C. plumosus*, as these small forms occur at a slightly higher geological horizon.

From a study of the specimens in the Yale University Museum, the following new data may be given: In no case does the length of the column exceed once and a quarter that of the crown, which varies from 5<sup>mm</sup> to 32<sup>mm</sup>. A large majority of those specimens which retain the column have very many unusually long cirri.

Several of the specimens have a feature which Bather states is found in some of the Camerata, and which he explains as being due to the fusing of the joints of the arms.\* In these forms the arms are composed of long joints, seemingly single, with the upper and lower surfaces parallel and horizontal. In parts of the arm, every other joint bears two pinnules on the same side of the ray. This alternation of one- and two-pinnuled joints does not extend throughout the whole length of the ray, but in places it is every third joint that has this peculiarity. Toward the base the joints are normal, that is, one-pinnuled. In his description, Hall mentions the fact that some of the joints have two pinnules; but in his figure,† he represents most



Text-figure 3. — Anal sac of *Cordylocrinus plumosus*. *a*, right postero-lateral radial; *b*, left postero-lateral radial; *c*, first of anal series of plates.  $\times 4$ .

\* A Treatise on Zoology, Pt. III. The Echinoderma, p. 116, 1900.

† Nat. Hist. N. Y., Pal., vol. iii, pl. 4, fig. 4, 1859.

of such joints as made of two, in this agreeing with Bather's explanation. The specimens under examination, although one is very well preserved, do not give the faintest trace of the separate joints; yet this explanation for the presence of the additional pinnules seems to be the most rational one yet offered.

Of the whole number of specimens examined, only one shows the anal tube mentioned by Hall. This tube is seen indistinctly in the photograph (pl. III, fig. 4; also text-fig. 3). The length of the tube is a little over half that of the crown.

*Horizon and locality.*—Upper third of the Coeymans limestone at Jerusalem Hill and at North Litchfield.

*Cotypes* in the American Museum of Natural History.

Order, ARTICULATA Wachsmuth and Springer.

Suborder, IMPINNATA Wachsmuth and Springer.

Family, *Ichthyocrinidae* Wachsmuth and Springer.

Genus, *Ichthyocrinus* Conrad.

*Ichthyocrinus schucherti* n. sp. Plate III, figure 1; text-figure 4.

*Specific description.*—Crown, including the incurved arms, an inverted, truncated cone with straight sides. Length and breadth equal, 19<sup>mm</sup>, the greatest breadth being at the point where the arms become free. Infrabasals not shown. Basals five, pentagonal. Radials five, hexagonal, wider than long. Costals three in each ray, wider than long, one hexagonal, the other two pentagonal, the upper supporting two rows of distichals, the first three ranges of which are quadrangular and the last pentangular and followed by two rows of palmars. The palmars are of different numbers in the different rays and even in different parts of the same ray. Two or three of the palmars are included in the cup. Each costal and each distichal is wider than the plate of the same order below it, but in the palmars there is a decrease in the size of the successive plates.

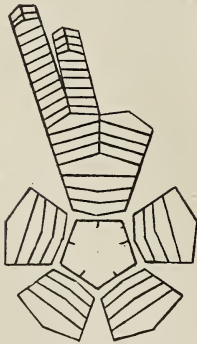

Text-figure 4.—Diagram of *Ichthyocrinus schucherti*.

Anal area not shown. Arms free from the second or third palmar, incurved. Each row of palmars divides at least once, making the number of branches forty. Column spreading slightly at the point of union with the crown. Joints of the column thin and equal near the calyx, alternating below, the larger ones about three times as high as the smaller. Length of column unknown.

A single individual of this species was found by Professor Schuchert and was presented by him to the Yale University Museum. It differs from other species of the genus, principally in the shape of the crown, the straight sides of the cup being very characteristic. It resembles *I. lœvis* more closely than any other, but differs from that species in the divisions of the rays and in the fact that the suture lines are not wavy.

*Horizon and locality.*—Lower third of the New Scotland limestone near Clarksville.

*Holotype* in the Yale University Museum.

Too little is known of the following Helderbergian crinoids to make definite statements in regard to their classification :—

Genus, *Aspidocrinus* Hall.

*Aspidocrinus callosus* Hall.

*Aspidocrinus callosus* Hall, Nat. Hist. N. Y., Pal., vol. iii, 1859, p. 123, pl. 5, figs. 13 and 14.—Wachsmuth and Springer, Rev. Palæocr., Pt. II, 1881, p. 228 ; Proc. Phila. Acad. Nat. Sci., vol. xxxiii, 1882, p. 402.

*Aspidocrinus digitatus* Hall.

*Aspidocrinus digitatus* Hall, Nat. Hist. N. Y., Pal., vol. iii, 1859, p. 123, pl. 5, figs. 19 and 20.—Wachsmuth and Springer, Rev. Palæocr., Pt. II, 1881, p. 228 ; Proc. Phila. Acad. Nat. Sci., vol. xxxiii, 1882, p. 402.

*Aspidocrinus scutelliformis* Hall.

*Aspidocrinus scutelliformis* Hall, Nat. Hist. N. Y., Pal., vol. iii, 1859, p. 122, pl. 5, figs. 15–18.—Wachsmuth and Springer, Rev. Palæocr., Pt. II, 1881, p. 228 ; Proc. Phila. Acad. Nat. Sci., vol. xxxiii, 1882, p. 402.

These species of *Aspidocrinus* present difficulties that are as yet unsolved. Hall described the forms as bases of crinoid cups, but Wachsmuth and Springer listed them doubtfully as crinoid roots. There are two reasons, at least, for thinking that they cannot be crinoid roots or basal expansions of columns. If they are basal expansions, the concave side must be the under side and this must have rested on the mud of the sea floor. One specimen of *A. scutelliformis* in the Yale University Museum has a bryozoan attached to this concave surface, proving that this surface could not have rested on the mud. If, on the other hand, these specimens represent the base of a cup, the presence of the bryozoan might be explained by supposing that its growth took place after the upper part of the dead calyx had been broken off but while the lower part still remained attached to the column.

Again, in undisputed examples of basal expansions, the lower or distal joints of the column enlarge and the segmentation of the column is continued into the upper part of the enlarged base. No such segments are visible in any of the specimens in question. In every good specimen, there is a clear-cut cir-

cular spot, generally dark-colored, which looks like the point of attachment of the column to the crown. With the exception of this spot, the cleavage lines of the calcite have obliterated all traces of organic structure.

*Horizon and locality.*—At the base of the Becraft limestone, or what was called the “Scutella limestone,” at Clarksville, Countryman Hill and Schoharie.

Genus, *Brachioocrinus* Hall.

*Brachioocrinus (Herpetocrinus?) nodosarius* Hall. Plate IV, figures 7 and 8.

*Brachioocrinus nodosarius* Hall, Nat. Hist. N. Y., Pal., vol. iii, 1859, p. 118, pl. 5, figs. 5-7, pl. 6, figs. 1-3. — Wachsmuth and Springer, Rev. Palæocœr., Pt. II, 1881, p. 229; Proc. Phila. Acad. Nat. Sci., vol. xxxiii, 1882, p. 413.

*Herpetocrinus nodosarius* Bather, Am. Geol., vol. xvi, 1895, p. 217.

In Hall's description, these fragments of crinoids are considered as arms or parts of arms; and this opinion was also held by Wachsmuth and Springer, in 1881. In 1895, Bather brought arguments to prove that they belong to columns, not arms,\* and even gave a revised diagnosis of these New York forms as *Herpetocrinus nodosarius*. That he is not so certain of this classification as the earlier paper would indicate, may be gathered from the fact that in a later reference to the fossil, he lists *Brachioocrinus* as doubtfully synonymous with *Herpetocrinus*.†

Among other points in support of his first view, he remarks that “cirri composed of thick, beadlike joints which increase in size from the base to the middle and thence diminish to the extremities,” characteristic of this species, are also found in *Herpetocrinus flabelliformis*, which occurs in the uppermost beds of the Silurian of Gotland.‡

Most of the specimens in the Yale collection are so encrusted with silica that it is very difficult to get anything but general outlines; but one specimen is in fairly good condition and clearly shows the joints of the column and the cirri. The joints are slightly wedge-form and quite thin, giving to the fossil an irregular appearance, which is still further increased by the difference in the size of the joints of the cirri. The diameter of the cirri is so great that only every third or fourth joint is cirrus-bearing. The bulb-like process, varying in size and shape, is shown in several specimens at the end of the column. The question has arisen whether this bulb is at the base of the stem, or whether it is simply a thickening somewhere between the proximal and distal ends. If the latter were the case, the central canal should show at both ends of

\* Am. Geol., vol. xvi, p. 213, 1895.

† A Treatise on Zoology, Pt. III. The Echinoderma, p. 146, 1900.

‡ Am. Geol., vol. xvi, pp. 215 and 216, 1895.



1

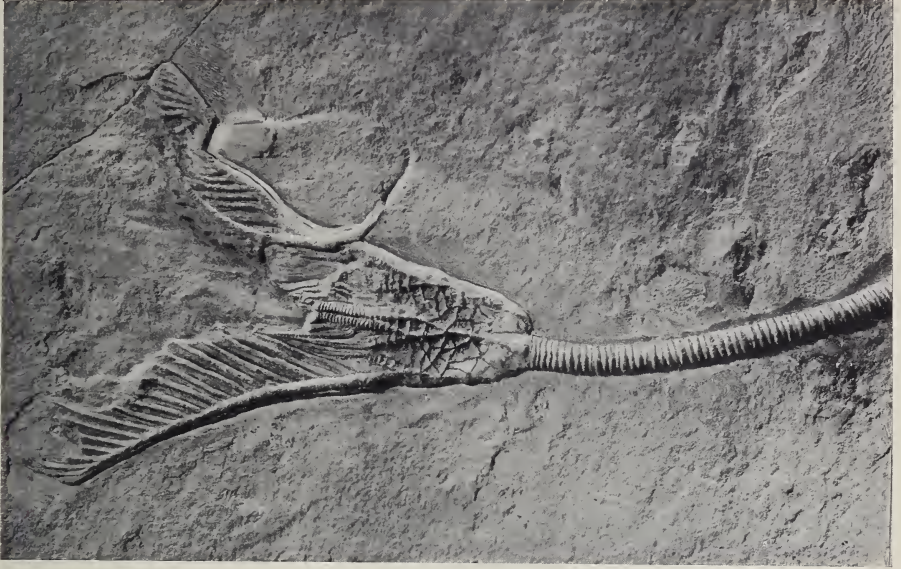

2

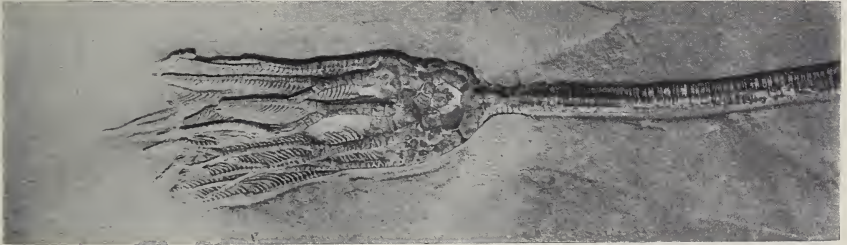

3



FIGURE 1.—*Melocrinus pachydaetylus*.  
FIGURE 2.—*Thysanocrinus arborescens*.  
FIGURE 3.—*Mariacrinus beecheri*.





*Melocrinus nobilissimus.*



1



2

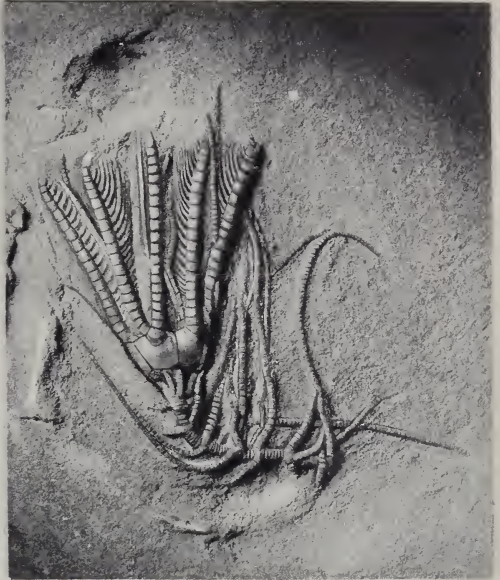

3

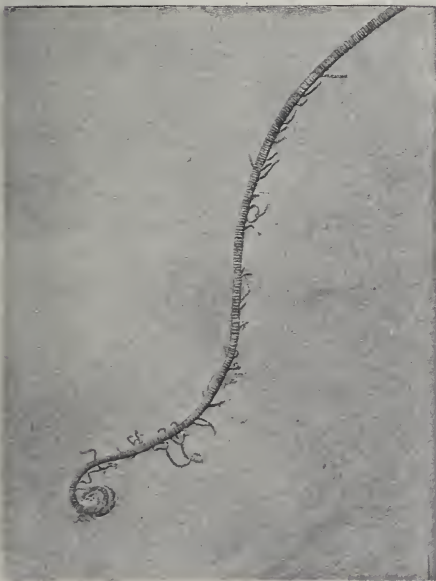

4



FIGURE 1.—*Ichthyocrinus schucherti*.  
FIGURES 2 and 4.—*Cordylocrinus plumosus*.  
FIGURE 3.—Stem of *Homocrinus scoparius*.



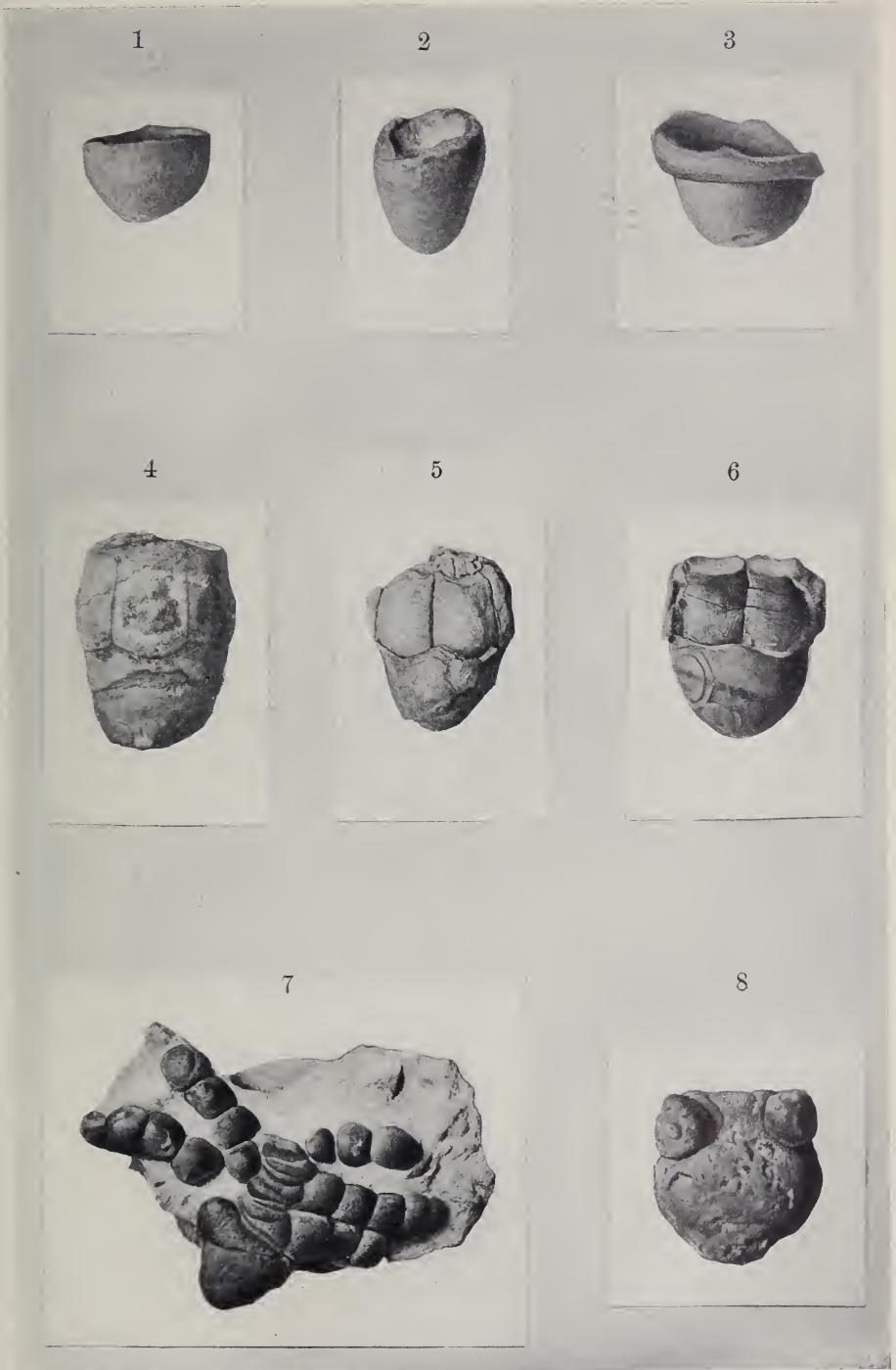

FIGURES 1-6.—*Edriocrinus pocilliformis*.  
FIGURES 7 and 8.—*Brachioocrinus nodosarius*.





the specimens. Although one individual shows the canal very well at the distal end of the cirri and the proximal end of the stem fragment, this canal is not visible at the distal end of the bulb on any individual under observation. A small depression on one specimen looks like a cicatrix of attachment. Several individuals have the crescentic form of the joints of the column, as in *Herpetocrinus*.

*Horizon and locality.*—Lower part of the New Scotland limestone in the Helderberg Mountains.

*Cotypes* in the American Museum of Natural History and the New York State Museum.

## EXPLANATIONS OF PLATES.

## PLATE I.

- FIGURE 1.—*Melocrinus pachydactylus*. About natural size.  
 FIGURE 2.—*Thysanocrinus arborescens* showing the hexagonal column and the branching of the arms. About natural size.  
 FIGURE 3.—*Mariocrinus beecheri* showing the thin stem joints near the crown and the separation of the two parts of the rays toward the distal end. About natural size.

## PLATE II.

Slab containing stems and crowns of *Melocrinus nobilissimus*. Reduced a little more than one-half.

## PLATE III.

- FIGURE 1.—*Ichthyocrinus schucherti* showing the characteristic straight sides of the crown and the straight suture lines.  $\times 2$ .  
 FIGURE 2.—*Cordylocrinus plumosus* showing the long, crowding cirri and the one- and two-pinnuled joints of the arms.  $\times 2$ .  
 FIGURE 3.—Distal end of the stem of *Homocrinus scoparius* showing the coiling and the delicate cirri.  $\times 2$ .  
 FIGURE 4.—*Cordylocrinus plumosus*. The upper specimen on the plate shows the anal sac.  $\times 2$ .

## PLATE IV.

- FIGURES 1-6.—*Edriocrinus pocilliformis*.  $\times 2$ .  
 FIGURES 1 and 2.—Simple ordinary forms, basals and infrabasals fused.  
 FIGURE 3.—Cup showing fused basals as a prominent ring, also cicatrix of attachment.  
 FIGURE 4.—Cup showing ring of basals, not protruding, and high narrow radials.  
 FIGURE 5.—Cup showing radials, but basals indistinguishable from infrabasals.  
 FIGURE 6.—Cup showing basals and infrabasals fused and radials fractured transversely.  
 FIGURES 7 and 8.—*Brachioocrinus nodosarius*.  $\times 2$ .  
 FIGURE 7.—Portion of the column showing the bulb at the distal end and the beadlike cirri.  
 FIGURE 8.—A larger bulb with the first joints of two cirri attached.

TABLE OF HELDERBERGIAN CRINOIDS.

Species with * also in the Siluric. Numbers refer to localities given below.	Coeymans.	New Scotland.	Becraft.	Location of the Type.
<i>Aspidocrinus callosus</i> Hall		1, 2		Holotype, Am. Mus. Nat. Hist.
“ <i>digitatus</i> Hall		2		“ N. Y. St. Mus.
“ <i>scutelliformis</i> Hall			2, 3, 4	Cotypes, Am. Mus. Nat. Hist.
<i>Brachioocrinus (Herpetocrinus?) nodosarius</i> Hall		1, 2		“ Am. Mus. Nat. Hist. and N. Y. St. Mus.
<i>Cordyloocrinus plumosus</i> (Hall)	5, 7			“ Am. Mus. Nat. Hist.
<i>Coronocrinus polydactylus</i> Hall		2		Holotype, N. Y. St. Mus.
<i>Eldriocrinus pocilliformis</i> Hall		3, 4		Cotypes, Am. Mus. Nat. Hist.
* <i>Homocrinus scoparius</i> Hall	2, 5, 6, 7			“ Am. Mus. Nat. Hist.
<i>Ichthyocrinus schucherti</i> n. sp.		3		Holotype, Yale Univ. Mus.
<i>Mariaocrinus beecheri</i> n. sp.	6			Cotypes, Yale Univ. Mus.
“ (?) <i>macropetalus</i> (Hall), referred provisionally to <i>Cordyloocrinus</i> by Wachsmuth and Springer				
<i>Mariaocrinus plumosus</i> Hall	7			Cotypes, Am. Mus. Nat. Hist.
“ <i>ramosus</i> Hall	7			Holotype, N. Y. St. Mus.
“ (?) <i>stoloniferus</i> Hall				“ N. Y. St. Mus.
<i>Marsupioocrinus tentaculatus</i> (Hall)		1, 2		Cotypes, Am. Mus. Nat. Hist.
<i>Melocrinus nobilissimus</i> (Hall)	6, 7			Holotype, Am. Mus. Nat. Hist.
“ <i>pachydactylus</i> (Conrad)	2, 5, 6			Cotypes, Am. Mus. Nat. Hist.
<i>Platyocrinus ramulosus</i> Hall	5			? Probably occurs in Cobleskill zone of the Manlius.
<i>Thysanocrinus arborescens</i> n. sp.	6			Holotype, Yale Univ. Mus.

1. The Helderberg Mountains.
2. Schoharie.
3. Clarksville.
4. Countryman Hill.
5. Jerusalem Hill.
6. North Litchfield.
7. Wheelock's Hill.

ART. V.—*The Petrographic Province of Central Montana*;  
by L. V. PIRSSON.

Introduction.  
Definition of the province.  
Consanguinity shown by minerals.  
    Augite.  
    Biotite.  
    Hornblende.  
    Feldspars.  
    Absence of minerals.  
Consanguinity shown in textural habit.  
Chemical evidence of consanguinity.  
    General law of the province.  
    Application to the region.  
Geographical arrangement of magmas.  
    Bearing on differentiation.  
Regional progression of types,

*Introduction.*

THE fact that in certain areas of the world's surface the igneous rocks have common characteristics, which serve to ally them together and to define them from the rocks of other areas, is now well recognized by petrographers. These common features are sometimes expressed in the minerals, sometimes in the chemical composition of the magmas and sometimes in peculiarities of texture, but usually in a union of these qualities. In some cases these features are clearly marked, in others they are but slightly developed; nevertheless, like those indescribable characters which define a man as belonging to one nation rather than to another, they are easily recognized by the experienced eye.

The formulation of this principle, that the rocks of a given region may be thus genetically related, we owe to Judd,\* and it has since been elaborated and applied with fruitful results to various regions by Iddings,† who developed it under the expression "*consanguinity of igneous rocks.*" Since then the idea has been applied to various regions by other petrographers; so, for example, Lacroix in a recent very interesting memoir on the alkalic rocks of northwest Madagascar, calls attention to the great belt of types rich in soda that stretches along the eastern coast of Africa.‡ Of all the various areas, however, where the consanguinity of igneous rocks has been studied and these relationships pointed out, there is probably none better known or more thoroughly investigated than that of South

\* Quar. Jour. Geol. Soc., 1886, vol. xlii. p. 54.

† Origin of Igneous Rocks. Bull. Phil. Soc. Washington, xii, p. 128, 1892.

‡ Roches alcaline de Prov. Petrograph. d'Ampasindava Nouv. Arch. d. Muséum, 4<sup>m</sup>e Ser., vols. i et v, 1902, 1903.

Norway, and our knowledge of this region we owe for the greatest part to the keen perception and untiring labors of Brögger, who has given the results of his work in that fine series of monographs which have become classics in the literature of petrography.

The fact that the outlying mountain groups east of the main chain of the northern Rocky Mountains are composed of rocks of a special character rich in alkalis, was pointed out by Iddings\* in the work already referred to, although at that time little was known about them. Since then investigations and studies in the field and in the laboratory by a number of workers have thrown a flood of light upon this region. In the Black Hills of North Dakota the work of Caswell,† Jaggard,‡ Irving§ and the writer|| has shown a prevalence of types rich in alkalis with soda dominating the potash.

In Montana, the most southern of the eastern outlying groups fronting the great plains, is the Crazy Mountains, some of whose interesting rocks of alkalic types are known through the researches of Wolff.¶ North of this come the various groups studied by Mr. Weed and the writer; the Castle Mountains,\*\* the Little Belt Mountains;†† the Judith Mountains;‡‡ the Highwood Mountains;§§ the Bearpaw Mountains;||| the Little Rocky Mountains¶¶ and lastly, on the border line between Canada and the United States, the Sweet Grass Hills,\*\*\* the last of the outliers. While some of these have been rather thoroughly investigated, there yet remains much to be done. The few types that have been described from the Crazy Mountains by Wolff, and its map††† showing the vast complexity of the

\* Op. cit., p. 31.

† Microscopic Petrography of the Black Hills, 1876. U. S. Geog. and Geol. Surv., Rocky Mts. region, J. W. Powell in charge. Rep. on the Black Hills of Dakota, pp. 469-527, Washington, 1880.

‡ Laccoliths of the Black Hills, 21st Ann. Rep. U. S. Geol. Surv., Pt. iii, pp. 163-290, 1901.

§ Geology of the northern Black Hills. Ann. N. Y. Acad. Sci., vol. xii, No. 9, pp. 187-340, 1899.

|| Phonolite Rocks from the Black Hills. This Journal, 3d Ser., vol. xlvii, pp. 341-346, 1894.

¶ Bull. Geol. Soc. Amer., vol. iii, pp. 445-452, 1892. Bull. Harv. Mus. Comp. Zool., vol. xvi, pp. 227-233, 1893.

\*\* Bull. No. 139, U. S. Geol. Survey, 1896.

†† 20th Ann. Rept. U. S. Geol. Surv., 1900, Pt. iii, p. 562. This Journal, 3d Ser., vol. i, pp. 467-479, 1895.

‡‡ 18th Ann. Rept. U. S. Geol. Surv., 1898, Pt. iii, p. 437-616.

§§ Bull. 237 U. S. Geol. Surv., 1905. Bull. Geol. Soc. Amer., vol. vi, pp. 389-422, 1895. This Journal, vol. ii, pp. 315-323, 1896.

||| This Journal, 4th Ser., vol. i, pp. 283-301, 351-362, and vol. ii, pp. 136-148, 188-189, 1896.

¶¶ Jour. of Geol., vol. iv, pp. 339-428, 1896.

\*\*\* This Journal, 3d Ser., vol. i, pp. 309-313, 1895.

††† Little Belt Mountains Folio, Montana. U. S. Geol. Surv., Geol. Atlas of U. S., No. 56, 1899.

dikes and sheets surrounding the main stocks of granular rocks, only serve to awaken general interest as to the character and relations of these rock masses, and it is to be greatly hoped that Professor Wolff will be able to continue his studies upon this interesting material and publish his results for the benefit of petrographers and for the understanding of the region. In the Bearpaw Mountains the researches of the writer upon the material collected during a hurried trip through them by Mr. Weed, which brought out such a variety of novel types of alkalic rocks, can only serve to demonstrate that this relatively large area must afford a fruitful field of study in the future; one whose complete investigation will add much to our knowledge of theoretic petrology and yield many interesting rock types.

The same must in large measure be true of the Sweet Grass Hills. The material studied by the writer gave types much like those of the Judith Mountains with hints of alkalic ones accompanying them, and the appearance of some specimens forwarded to Mr. Weed would seem to indicate that rocks of tinguoid habit occur there. Adding these facts to Dr. Dawson's\* descriptions, it would seem as if they might consist largely of laccoliths probably with accompanying sheets and dikes similar in character and in rocks to those of the Judith and Little Rocky Mountains and the Black Hills.

#### *Definition of the province.*

That part of this great region which has been studied by the writer, and with which he is therefore most familiar, lies in the center of Montana and embraces as its foci of igneous activity the Castle, Little Belt, Judith, Highwood, Bearpaw and Little Rocky Mountains. Since the general reader cannot be expected to be familiar with the geography of this region and the disposition of these groups, their arrangement with respect to one another and to the main chains of the Rocky Mountains is shown on the accompanying sketch map. It will there be seen that they lie in a roughly oval area stretching from the northeast towards the southwest, about 150 miles long by about 100 broad, in the middle of Montana and shown on the map by the dotted line. It is this region which it is here proposed to define as the petrographic province of central Montana; the consanguinity and general family relations of whose rocks it is intended to describe.

This paper then may be considered as a general summation along the line just mentioned of the work of the writer on these different mountain groups, presenting the broad petrologic features they possess in common. For the separate

\* Rep. Canadian Geol. Surv., 1882-4, Pt. C, pp. 16 and 45.

details the reader is referred to the series of memoirs upon them whose list is given upon a foregoing page.

The evidences of consanguinity are to be seen in two ways, in certain mineral peculiarities and in the chemical composition of the magmas, the first being dependent upon the second in conjunction with the physical conditions attendant upon crystallization.



Map of Central Montana showing arrangement of mountain groups in petrographic province.

#### *Consanguinity shown by minerals.*

*Augite.*—One of the most marked features in regard to the mineral composition of this composite geographical rock family is to be seen in the augite. This has been already pointed out by Iddings,\* but its application to this province is worthy of special mention.

The augite is of a distinct green color, very rarely pleochroic. It varies from very pale to a deep green. Brown or purplish augites are rare. They do occur in some of the lamprophyric dikes and flows but are exceptional, so that in a great preponderance of the rocks the green augite distinctly rules. Moreover this applies through the whole series from

\* Op. cit., p. 131.

the most salic to the most femic types, the depth of color usually increasing somewhat towards the ferromagnesian pole. It is commonly supposed that the purplish color of augite is due to the titanite oxide it contains; and while this perhaps is true, it should nevertheless be pointed out that one of these green pyroxenes from the shonkinite of Square Butte, analyzed by the writer, contained over a half per cent of titanite oxide. It is also to be noted that titanite oxide occurs in all of these rocks, gradually increasing with the iron towards the ferromagnesian pole, yet the rocks towards this end still have the strong green color in the pyroxene. This is especially noticeable in the shonkinites of Yogo peak in the Little Belts, in the various occurrences in the Highwoods and in the Beaver stock and elsewhere in the Bearpaws, the  $TiO_2$  ranging from 0.75 to 1.50 per cent, the silica falling as low as 46 per cent in the latter case. The occurrence of this green augite through the whole series is more strongly marked in the Highwoods than elsewhere and this local peculiarity did not escape Lindgren's notice and he makes especial mention of it,\* not only for the Highwoods but for the other groups of the region with which he was acquainted. There is no notable exception to this rule in any of the Highwood rocks numbering several hundred occurrences studied by the writer, no matter how salic or femic the types may be.

This green augite is a marked feature then of this petrographic province, and in this respect it appears to differ from many other well-marked provinces of alkalic rocks. In the exceptional cases mentioned above, the augite is pale brown, strong purplish colors not having been noted, so far as the writer can recall, in the whole province.

In the salic rocks rich in alkalis, aegirite-augite appears: this is a marked feature of those of tinguoid habit; aegirite itself is rare. This seems to be due to the dominance of potash over soda, as will be shown in the discussion of the chemical peculiarities of the province. It is possible that the characters of the pyroxene, including its green color and non-pleochroism, are also due to this general chemical character of the magmas.

*Biotite.*—Throughout the province the biotites are the brown, strongly pleochroic variety—ordinary biotite. The red-brown biotites of the theralite rocks found in the Crazy Mountains to the southward do not occur, nor the pale phlogopites of the rocks rich in potash of the Leucite Hills in Wyoming as described by Zirkel† and Cross.‡ In some exceptional

\* 10th Census United States, vol. xv, p. 726, 1886.

† Micro. Petrog. 40th Parallel Surv., vol. vi, p. 261.

‡ Igneous Rocks of the Leucite Hills and Pilot Butte, Wyoming; this Journal, vol. iv, 1897, p. 120.

cases of the lamprophyric dike rocks the biotites have darker borders, otherwise they are very uniform in all classes alike.

*Hornblende.*—This mineral is, comparatively speaking, of limited occurrence. It is found in an alkalic type in Square Butte syenite (pulaskose), and in the trachyandesite (adamellose) flow on North Willow creek in the Highwoods, and in some of the porphyries composing the laccoliths in the various mountain groups and in vogesite dikes in the Castle and Little Belt Mountains; but, with these exceptions, when it occurs it is clearly uralitic after augite. In this province augite rules in the vast majority of cases and even in the quartzose rocks (quardofelic types) it appears rather than hornblende.

*Feldspars.*—It cannot be said that there is any specially marked evidence of consanguinity to be seen in these minerals so far as the author is able to detect. They do not present, for instance, any such remarkable features as those seen in the feldspars of the alkalic rocks of south Norway, shown in their greatest development in the phenocrysts of the rhombic porphyries. It is to be noted, however, that on account of the tendency for potash to dominate soda in the magmas, that orthoclase or soda-orthoclase is commonly the chief feldspar. Albite is of rare occurrence, even in the strongly alkalic types free from plagioclase, the one instance which is an exception to this—the porphyry of Lookout Butte\* in the Little Rockies—being a notable exception. On the other hand, it is an interesting fact that in spite of the strong predominance of potash feldspar in so many occurrences of all kinds, microcline may be said to be absolutely wanting in the province. It is probably due to the comparatively recent and hypabyssal character of these rocks and the fact that they have not been subjected to dynamic pressures.

*Absence of minerals.*—The characters of a petrographic province are shown as much by the absence of some minerals as by the presence of others. In this one it is shown by the rarity or absence of minerals caused by the groups of rare earths—as they have, somewhat infelicitously, been called,—that is minerals marked by the presence of zirconia, thoria, cerium, lanthanum, didymium, columbic oxide, etc., etc. Even titanite is a rather rare mineral and zircon uncommon. Experience would seem to show that it is chiefly magmas rich in soda which these oxides accompany and that the potassic dominance in the magmas of the central Montana province tends to exclude them and to produce rocks lacking in the interesting minerals they give rise to.

\* Jour. of Geol., vol. iv, p. 422, 1896.



*Consanguinity shown in textural habit.*

In some cases the consanguinity of the rock family is shown in the repetition of certain textural habits. Thus the pseudo-leucite basalts of both the Highwoods and the Bearpaws closely resemble each other and both of them differ in habit from the leucitic rocks of other regions, from those of Italy for example. A most marked instance is also seen in the minettes of Highwood type (phyro-biotitic-cascade). These occur not only in the Highwoods but thirty miles to the north-east on the Missouri River Mr. Weed collected similar rocks and they occur doubtless in the Bearpaw Mountains.\* One of these from the Missouri River so exactly resembles the occurrence on Williams Creek on the south slope of the Highwoods and described in the memoir on the Highwood rocks† that hand specimens of the two cannot be distinguished from one another. So too, while each occurrence of shonkinite in the region, in the Little Belts, the Highwoods and the Bearpaw has its own peculiarities, yet taken together they form in sum total a well marked family group.

In the salic, feldspathic types, on account of their simpler composition these evidences of family relationship are less distinctly marked, and yet in the porphyries composing the laccoliths in all the groups of the province, there appears to be a tendency towards the repetition of a type with a certain textural habit difficult to describe but easily recognizable. It appears to be largely conditioned by a certain abundance, size and disposition of phenocrysts. There are many wide exceptions and variations of this, nevertheless the rule holds.

*Chemical evidences of consanguinity.*

The strongest evidences which show that the rocks of these various groups belong to a common family are to be found in comparing their chemical compositions. For this purpose a sufficient number of analyses are available for the Castle, Little Belt, and Highwood Mountains. For the Bearpaws there are enough to show the general character of the magmas, though more would be desirable. For the Judith and Little Rocky Mountains there is only one for each, but the general similarity of the types, shown by their petrographic study, is sufficient to indicate that they must agree in essential chemical characters, and as the rocks are of very similar nature and of simple types the two analyses must supplement each other fairly well. The Moccasin Mountains, which are two compound laccoliths, are practically a part of the Judith Mountains, and their rocks,

\* Judging from Dawson's description (op. cit., p. 46) it seems probable that the same type also occurs in the Sweet Grass Hills.

† Igneous Rocks of the Highwood Mts., Bull. No. 237, U. S. Geol. Surv., 1904, p. 142.

as shown by Lindgren's\* brief description and by specimens collected by Mr. Weed, are mainly composed of feldspar porphyries similar to those of the Judith Mountains.

In all 58 analyses have been made and published of rocks of this province, 15 by H. N. Stokes, 12 by W. F. Hillebrand, and one by W. H. Melville in the laboratory of the United States Geological Survey; 16 by the author and 14 under his direction by Messrs. H. W. Foote and E. B. Hurlburt in the laboratories of the Sheffield Scientific School in New Haven. It is not

*Castle Mountains Magmas.*

	1	2	3	4	5	6	7
SiO <sub>2</sub> -----	74.9	65.9	61.9	56.8	46.5	45.1	42.5
Al <sub>2</sub> O <sub>3</sub> -----	13.6	16.8	17.3	18.3	10.5	15.4	12.0
Fe <sub>2</sub> O <sub>3</sub> -----	.7	1.6	2.3	1.6	4.4	2.8	3.2
FeO -----	.5	1.2	2.4	5.6	7.8	5.6	5.3
MgO -----	tr	1.5	1.8	3.6	10.6	6.5	12.4
CaO -----	.6	2.6	3.2	5.3	9.5	8.8	12.1
Na <sub>2</sub> O -----	4.2	4.7	5.2	4.3	3.1	2.8	1.2
K <sub>2</sub> O -----	4.6	3.1	3.8	3.3	1.5	2.8	2.7

*Little Belt Magmas.*

	8	9	10	11	12	13	14	15	16	17	18
SiO <sub>2</sub> ----	73.1	69.7	68.6	64.9	61.6	62.2	54.4	52.3	48.3	48.4	49.0
Al <sub>2</sub> O <sub>3</sub> ---	14.3	15.0	16.1	15.4	15.1	15.8	14.3	14.0	13.3	11.6	12.3
Fe <sub>2</sub> O <sub>3</sub> --	.5	.8	2.2	2.0	2.0	1.8	3.3	2.8	4.4	4.1	2.9
FeO ----	.3	.3	.4	1.6	2.2	2.4	4.1	4.4	3.2	3.6	5.8
MgO ---	.2	.7	.7	2.6	3.7	3.5	6.1	8.2	8.4	12.5	9.2
CaO ----	1.1	2.1	1.4	3.1	4.6	4.1	7.7	7.1	9.9	7.6	9.6
Na <sub>2</sub> O ---	3.4	3.4	4.4	4.2	4.3	3.9	3.4	2.8	3.3	4.1	2.2
K <sub>2</sub> O ----	4.9	4.4	4.9	3.9	4.5	3.9	4.2	3.9	3.0	3.2	5.0

*Highwood Magmas.*

	19	20	21	22	23	24	25	26	27	28	29	30	31
SiO <sub>2</sub> ---	65.5	59.2	58.0	57.2	56.4	55.2	51.9	51.7	49.6	47.8	48.0	46.0	46.1
Al <sub>2</sub> O <sub>3</sub> --	17.8	13.8	17.2	18.5	20.1	18.3	15.8	14.5	14.5	13.6	13.3	12.2	10.0
Fe <sub>2</sub> O <sub>3</sub> --	.7	5.5	2.5	3.6	1.3	4.9	4.1	5.1	3.5	4.7	4.1	3.9	3.2
FeO ----	1.1	1.4	1.2	1.1	4.4	2.1	3.2	3.6	5.5	4.5	4.2	4.6	5.6
MgO ----	1.0	4.8	1.8	.7	.6	1.8	3.5	4.6	6.2	7.5	7.0	10.4	14.7
CaO ----	1.9	5.6	3.5	2.3	2.1	3.6	6.0	7.0	9.0	8.9	9.3	9.0	10.5
Na <sub>2</sub> O ---	5.5	3.1	3.4	4.5	5.6	4.0	3.4	2.9	3.5	4.4	3.5	2.4	1.3
K <sub>2</sub> O ----	5.6	4.2	10.1	8.6	7.1	6.4	7.7	7.6	5.6	3.2	5.0	5.8	5.1

*Bearpaw Magmas.*

	32	33	34	35	36	37	38	39	40
SiO <sub>2</sub> ----	66.2	68.3	57.5	52.8	51.9	50.0	46.5	68.7	57.6
Al <sub>2</sub> O <sub>3</sub> ---	16.2	15.3	15.4	15.7	20.3	9.9	11.8	18.3	17.5
Fe <sub>2</sub> O <sub>3</sub> ---	2.0	1.9	4.9	3.1	3.6	3.5	7.6	.6	3.5
FeO ----	.2	.8	.9	4.8	1.2	5.0	4.4	.1	1.2
MgO ----	.8	.5	1.4	5.0	.2	11.9	4.7	.1	.2
CaO ----	1.3	.9	2.6	7.6	1.6	8.3	7.4	1.0	1.4
Na <sub>2</sub> O ---	6.5	5.5	5.5	3.6	8.5	2.4	2.4	4.9	5.8
K <sub>2</sub> O ----	5.8	5.6	9.4	4.8	9.8	5.0	8.7	4.7	9.2

*Little Rocky and Judith Magmas*

\* This Journal, 3d Ser., vol. xlv, pp. 286-297, 1893.

worth while, however, to give all these analyses,\* for some of them from a given area, for our purposes, would be merely repetitions of one another, and in this case only one is selected to represent this variety of magma. Only the essential elements are given and consequently the summations are omitted. In examining these tables of analyses the first thing that is evident is that in general, high silica, alumina and alkalis go together and are opposed to lime, iron and magnesia. This is of course merely a general truth applicable to all igneous rocks and not a special character of the province. The special and most obvious feature which distinguishes this district is in the relation of alkalis to one another and to silica. The potash dominates over the soda.

*General law of the province.*—Definitely stated it is this; *The petrographic province of central Montana is characterized by the fact that in the most siliceous magmas the percentages of potash and soda are about equal; with decreasing silica and increasing lime, iron and magnesia, the potash relatively increases over the soda, until in the least siliceous magmas it strongly dominates.* An inspection of the tables will show that there are but a few partial exceptions to this law in the 40 analyses given, and since all which are exceptions are given, the 18 omitted analyses would merely add the weight of additional figures to the truth of the law.

*Application to the region.*—It will be of interest now to examine this more in detail with respect to the various mountain groups. The Castle Mountains lie on the extreme southern border of the province; their next neighbor to the south is the Crazy Mountains group, and an examination of analyses from that district† shows that in the magmas soda strongly dominates the potash throughout the series. The writer has already shown‡ that the general Castle magma was one of a very salic character, in fact that of a granite, and that femic rocks play but a small role. Thus in the siliceous types we see the influence of the nearby Crazy Mountains' magma; the soda here slightly dominates the potash; we are on the edge of the province and the rocks are transitional. The relation to it is seen however in the most femic type, since here potash dominates the soda. As we go northward from here into the province the Little Belt rocks came next and its characters become more evident. In percentages potash begins to rule even in the siliceous types and in the extreme femic types this peculiarity is strongly marked. Only two exceptions are noted, both of which are given and both of which are narrow dikes. Their exceptional

\* They may be found in the works previously cited.

† Bull. U. S. Geol. Surv. 168, pp. 120-124, 1900.

‡ Geology of the Castle Mountain Mining District, Bull. U. S. Geol. Surv. 139, p. 138.

position in the Little Belt series has been already discussed.\* In the siliceous rocks the dominance of potash as one goes toward the center of the province sometimes expresses itself more strongly; thus in the granite porphyry of Wolf Butte on the extreme northern edge of the Little Belts the relations are  $K_2O : Na_2O = 4.4 : 3.3$ , as shown in an analysis not quoted above.

Next north beyond the Little Belts and near the center of the province are the Highwoods, and here its characters reach their highest development. The most siliceous type has equal percentages of soda and potash; there is only one occurrence, the syenite of Highwood peak; in the others the potash strongly dominates, increasing towards the femic end until in missourite it is 4 to 1. There is only one exception in this group which has been found, No. 28 in the table. It is the analcite basalt of Highwood Gap, occurring in narrow dikes.

The general line through the province to the northward now bends to the east toward the Bearpaws. Between the Bearpaws and the Highwoods there is an occurrence of igneous rocks in small stocks and dikes on the Missouri river. They have not yet been thoroughly investigated, but the study of sections made from specimens collected by Mr. Weed shows them of femic types like those occurring in the Highwoods. They are in fact largely minettes of Highwood type, as previously mentioned, and all their characters show that they closely conform to the general law and that potash rules.

Next beyond these come the Bearpaws, in which the general law of the province strictly holds. It is to be noted that towards the southern side the rocks are femic, and as we pass through the group we find on the northeast, on the edge of the province, salic (quardofelic) types occurring in laccoliths again as in Eagle Butte, the analysis of whose rock is shown in No. 32. Again here as on the southern edge the soda rises until it slightly exceeds potash.

Southeast of here, defining the edge of the province in that direction, are the Little Rockies, another laccolithic intrusion of salic types. There is some variation and the rocks pass into a tinguaitic phase. Exactly of the same character are the Judith Mountains; also a boundary group on the edge of the province, of salic types running into tinguaites. There is as yet only one analysis from each of these groups, one of a granite porphyry from the Little Rockies No. 39 and one of a tinguaitite (judithose) from the Judith Mountains. Thus they supplement each other and the general law holds true, the potash increasing as the silica falls. It is also to be noted that in neither of these boundary groups do any femic types occur.

\* Petrography of the Little Belt Mts., 20th Ann. Rep. U. S. Geol. Surv., Pt. iii, p. 576.

So far as is known, the Sweet Grass Hills off to the northwest agree with the last two groups, but the absolute confirmation of this must await future exploration and study. Moreover they are somewhat outside of the general area under discussion. In this connection however there might be mentioned Big Snowy Mountain, south of the Judith Mountains. This is evidently a large laccolithic uplift, and from the Judith Mountains the heavy white Carboniferous limestones dipping away from it are clearly seen. Intelligent mining prospectors, who have searched the mountain for ore deposits, have assured me that it is all limestone on top and that no porphyry is exposed. The laccolithic roof has evidently not yet been eroded away, but considering all the facts of structure and occurrence in this province, there can scarcely be reasonable doubt that a concealed body of feldspathic porphyry lies underneath the limestone dome.

#### *Geographical Arrangement of Magmas.*

From what has been already said, it is now evident that there is a rather orderly arrangement of magmas in the province. Around the outer edge they tend to be strongly siliceous, low in lime, iron and magnesia, and with the percentages of soda about equal to those of potash, and these magmas have usually marked their upward movement and intrusion by the formation of laccoliths. One can say in truth that the boundary of the province on the south, southeast, east, north and if it be extended to include the Sweet Grass Hills, on the northwest, is defined by laccoliths or groups of laccoliths of a rather definite type of magma. On the west the boundary is not yet well known and is perhaps not so clearly defined. At all events, in this direction it is eventually cut off by the main ranges of the Rocky Mountains, whose magmas, so far as we know them, are of a quite different character, belonging in fact to the granite-diorite series whose surface equivalents are rhyolites, andesites and basalts.

On the border line of the province thus defined femic types are rare or wanting. When they appear, however, they tend to assume the regional character and potash rises. As we approach the center of the province they become more numerous and of larger volume and as silica sinks the potash rises. This is shown by the occurrences of monzonite and shonkinite in the Little Belts and on its northern edge. Finally, in the central portion of the province in the Highwoods, on the Missouri river and in part of the Bearpaws the magmas are distinctly femic and rocks rich in ferro-magnesium components form the largest masses, are most numerous in occurrence and distinctly rule. There is still a recurrence of salic types, but they are of small volume and of diminished importance.

This arrangement of magmas over the region is of course not so well displayed as if there had been outbreaks of lava and igneous intrusions in every ten square miles of it and all conforming to the rule, but it is believed by the writer that one who reads carefully the facts previously stated and studies the map must be struck with the disposition of the magmas about a common center as shown in the mountain groups. It does not appear as if this could be mere chance; on the contrary, it certainly seems to point to an orderly arrangement of things according to some definite cause, whether we are able to discover the latter or not.

*Bearing on Differentiation.*—It will be noticed that this arrangement is contrary to what obtains in most cases of local differentiation such as those of Yogo and Bearpaw peaks and Square Butte in this province, in which the border zones are femic with a concentration of the salic components towards the center. Washington\* has shown that at Magnet Cove the contrary is the case, the outer zone being more salic and the inner part of strongly femic types. An instance of this also occurs in this province in the "diorite" intrusion of Castle Mountain near Blackhawk,† which at the center is a monzonoid rock with 56 per cent of silica and grows steadily more siliceous towards the periphery until it becomes a quartzose porphyritic type. Other examples are described by Brögger‡ in Norway and Ramsay and Hackmann§ in Lapland.

Washington in discussing these cases|| is inclined to view them as results of processes of solution and crystallization in which the magma, composed of silica, alumina and alkalies, is the solvent, the others being the solutes, and the solvent being in excess tends to crystallize first at the outer margins. This might explain such cases of *local* differentiation as are seen in laccoliths like Square Butte, but it is clear that it could not be applied to whole regions. For granting for the moment that a parent body of homogeneous magma can form diverse smaller bodies by some process, it could not do so over wide areas by one of solidification; the facts demand that the cleaved products should remain liquid though these secondary bodies, after intrusion into place, might yield diverse products by crystallization. The writer is not inclined to believe, on the other hand, that pure molecular flow, which Becker¶ has shown must take place with great and increasing slowness, can be a sufficient

\* *Igneous Complex of Magnet Cove*, Bull. Geol. Soc. Amer., vol. xi, p. 407, 1900.

† Bull. 139, U. S. Geol. Surv., pp. 134 and 140, 1896.

‡ Brögger: *Zeit. f. Kryst.*, vol. xvi, 1890, p. 45.

§ Ramsay and Hackmann: *Fennia*, vol. xi, No. 2, 1894.

|| *Loc. cit.*, p. 408.

¶ This Journal, vol. iii, p. 21, 1897.

*modus operandi* on a vast scale. But within limits and with sufficient time it may be a factor of importance, and combined with convection currents and forced movements on a small scale due to the passage of heated gases, and on a large one to dynamic movements of the crust, a variety of agencies may be brought into play which may be sufficient to render a body of homogeneous magma, even if of considerable size, quite diverse in its parts. And it is to be clearly noted that this is quite independent of the question as to whether the magma shell of the molten earth (supposing there ever was such a thing) was ever homogeneous or not. This is purely an academic question and may always, as at present, remain a matter of mere speculation. Whether it was or not, the magmas underlying the crust are different now in different regions, and this is the basic fact with which the petrographer has to concern himself.

On the other hand, it is the writer's belief that it would be unreasonable to throw away such indications as those afforded above, that the distribution and occurrence of igneous rocks are not due to mere chance; to deny they are governed like other things in nature by definite laws and processes; to affirm that they are caused by mere haphazard heterogeneity of the underlying magma, and to thus dispose of the subject by relegating it to chaos.

In regard to *local* as distinguished from *regional* differentiation, we know something of the conditions and occurrences most favorable for its operation of the magmas in which it is most likely to occur and to predict some of the probable results of its operation. But in regard to the latter it does not seem to the writer quite reasonable to assume that agencies and processes that would be operative on a small scale would be necessarily applicable to vast bodies of magma underlying great regions. The writer has already discussed this phase of the subject in another place and it is not necessary to repeat it here.\* But in the writings and speculations of many petrographers a good deal of confusion on this subject appears and the differentiation of huge "magma basins" presumably covering hundreds and even thousands of square miles, is discussed in the same terms and with appeal to the same supposed agencies as has produced visible results in a single dike, laccolith or other relatively small rock body. In the writer's opinion this is wrong and will only tend to throw discredit upon what has so far been produced that is of real value. It must be confessed that at the present time so little is known and so much remains to be discovered that any attempt, from the

\* Igneous Rocks of the Highwood Mountains, Bull. 237 U. S. Geol. Surv., p. 183.

data in hand, to solve the problem of general differentiation over wide regions must be a mere speculation. While the physical chemist therefore is attacking the problem on one side, it remains for the petrographer, on the other, to gather data regarding the occurrences of igneous rocks and their interrelationships and characters over definite areas, and the present article can be considered as a contribution towards this end.

#### *The Regional Progression of Types.*

It is desired to call attention here to a phase of the occurrence of rock types in the province in the hope that petrographers may observe if it is of general application in different petrographic provinces.

In lieu of a better name it may be called the *regional progression of types*, and the idea involved in this term is as follows: while in a given province there are certain family characters serving to bind the various rock types into one clan, yet from place to place within its limits the magmas may vary greatly from each other, and there may be, as in the Montana province, a number of centers with complexes of their own. It is so to speak that the clan is made up of a number of families each of which consists of individuals. In traversing the area from one family to another, the observer will note that certain types which are rare or sporadic in the first will become numerous or even dominating ones in the second. Long before the second family is reached its types begin to appear, and as the area is approached they are likely to become more numerous, then attain their greatest frequency and die away beyond. Thus there is an overlapping of types and the rare one of a given center of igneous rocks becomes the common one of a neighboring center. It of course depends upon the gradual change in the character of the magmas.

Some instances of this which have been observed in this province are as follows. In the Castle Mountains a single sporadic case of a monchiquoid rock was observed.\* Going northward into the Little Belts they begin to be more common, and the author has described them under the name of "analcite basalts,"† while still farther to the northward in the Highwoods these are exceedingly common rocks. They occur for the greater part in dikes but in the Highwoods in flows also. In the midst of the Castle rocks this type appeared out of place when considered only by itself, but if we consider it not as a member of the Castle family, but of the central Montana clan, its occurrence falls into order.

\*Bull. 139 U. S. Geol. Surv., pp. 68 and 114, 1896.

†Petrog. Little Belt Mts., 20th Ann. Rep. U. S. Geol. Surv., Pt. iii, p. 543, 1900.



Again, in the Castle district the stock at Blackhawk described under the name of "diorite" has its central portion developed as a monzonoid facies, as may readily be seen by reference to its description and analysis.\* In the Little Belts to the north monzonite occurs in a considerable mass at Yogo Peak,† and in the Highwoods‡ and Bearpaws§ it is a prominent type.

Or again, shonkinitic facies of rock masses are found at Yogo Peak in the Little Belts and in the stock at the head of Beaver Creek in the Bearpaws, while in the Highwoods this rock is the common type and found in numerous masses.

So also rocks of tinguoid habit do not occur at all in Castle Mountain or in the Little Belts in the southern part of the province. They first begin to appear in the Highwoods in the middle part; here they are rare, only a few occurrences being noted, but in the Judith,|| Little Rocky¶ and Bearpaw\*\* Mountains which define the northern part of the province they are very common rocks.

Other instances might be cited but these are sufficient to indicate the idea involved. It is in intrusive rocks of various kinds of occurrence, and perhaps more noticeably in dikes, that this progression of types is seen. The extrusive rocks do not occur so generally in this province that it may be observed among them.

It would be a matter of interest to know if this progression of types is a peculiarity confined to this province and occasioned by the local distribution of magmas or whether it is of more general application. The writer has observed indications of it in other places, as, for instance, in central New Hampshire, where at Red Hill and Mount Belknap centers of alkalic magmas occur. These are indicated at long distances by sporadic dikes of bostonoid and camptonoid habits, the latter becoming very numerous at the actual centers. But outside of the central Montana area the writer has not that intimate acquaintance with other broad petrographic provinces which is necessary to be able to apply this idea to them, and it must be left to others. It would seem as if south Norway and central Italy and perhaps the Bohemian Mittelgebirge, which is being so ably investigated by Hibsich, might afford good examples.

Sheffield Scientific School of Yale University,  
New Haven, Conn., December, 1904.

\* Bull. 139, p. 89.

† Petrog. Little Belt Mts. p. 475.

‡ Bull. 237, p. 76.

§ This Journal, vol. i, p. 355, 1896.

|| 18th Ann. Rep. U. S. Geol. Surv. Pt. iii, p. 566, 1898.

¶ Journal Geol., vol. iv. p. 419, 1896.

\*\* This Journal, vol. ii, p. 189, 1896.

ART. VI.—*Croomia pauciflora* Torr. An anatomical study; by THEO. HOLM. (With one figure in the text drawn by the author.)

MANY years ago *Croomia* was considered a member of the *Berberidaceæ* and an ally of *Berberis*, *Caulophyllum*, *Diphyleia*, *Jeffersonia* and *Podophyllum*,\* with the admission, however, that the examination of a single seed did not disclose whether the plant was dicotyledonous or not, and that the affinity in either case remained obscure. Several years later the mistake was corrected by Gray himself and the genus referred to the *Roxburghiaceæ*.† Besides the American species there is another one in Japan: *C. Japonica* Mig., but these two are the only ones, known so far, of this singular genus. The monotypic *Stichoneuron* and the small genus *Stemona* Lour. (*Roxburghia* Banks) are with *Croomia* the only representatives known of the order. Habitually these genera are quite distinct, *Stemona* being a tall climber, the others low herbs; the floral structures have been carefully described by Gray, Bentham and Hooker, and Engler and Prantl. A more detailed account of the morphology of the flower as well as the anatomy of the vegetative organs of some species of *Stemona* has been given by Mr. Lachner-Sandoval.‡ In regard to *Croomia* Gray pointed out some few peculiarities in the stem-structure, sufficient to prove that its systematic position would have to be sought among the *Monocotyledones*, but otherwise the genus has not been studied from this particular point of view.

Having received some fresh material from Alabama, we have examined the internal structure of the vegetative organs of *Croomia*, and the following notes may be considered as supplemental to those of Mr. Lachner-Sandoval for illustrating the comparative anatomy of this peculiar little order. A few remarks upon the rhizome may, also, be inserted at this place.

As stated above, *Croomia pauciflora* is a low herb with a few green leaves and two- or three-flowered inflorescences near the apex of the single stem. The rhizome represents a sympodium; it is slender, horizontally creeping with stretched internodes and scale-like, membranaceous leaves. The terminal bud produces the aerial, flower-bearing stem surrounded at the base by three scale-like leaves, while a bud from the axil of the lowermost of these pushes out into a horizontal, subterranean branch, which continues the direction and growth of

\* Gray, Asa: *Genera floræ Americæ bor.-orient. ill.* Vol. i, 1848, p. 90.

† Same: On the genus *Croomia*, and its place in the natural system. (*Mem. Amer. Acad. Sc.*, Ser. 2, vol. vi, 1859, p. 453, plate 31.)

‡ Beitrag zur Kenntniss der Gattung *Roxburghia*. (*Botan. Centralb.*, vol. 1, 1892, p. 65.)

the mother-rhizome. Dormant buds may be observed in the axils of some of the leaves of the horizontal portion of the rhizome. The roots are white, somewhat fleshy and sparingly ramified; they develop mostly below the nodes or, sometimes, a little above these.

In the Japanese species *C. Japonica* Mig. the habit of the plant is the same, but the flowers are single in the axils of the leaves, and the rhizome has no stretched internodes.

The internal structure of the vegetative organs of our species of *Croomia* shows several points of interest, when compared with the allied orders, and we will begin with the roots.

#### *The roots.*

The secondary roots are storage-roots with no contractile power; they are nearly glabrous and the thin-walled epidermis persists covering directly the cortical parenchyma, no hypoderm being developed. The cortex consists of about fifteen layers of thin-walled, starch-bearing cells, constituting a rather compact tissue. There is an endodermis of exceedingly small cells with thin walls and the Casparyan spots barely visible; it surrounds a continuous similarly thin-walled pericambium. Inside this are seven narrow rays of hadrome with one to two protohadrome vessels and about twenty, much wider, around a narrow central group of moderately thickened conjunctive tissue.

The thin, lateral roots show a like structure, but the cortex contains no starch and the endodermis is large-celled with the spots plainly visible; these roots were diarchic and the position of the protohadrome vessels was like that in the mother-root, inside the pericambium.

#### *The rhizome.*

When we examine one of the stretched, horizontal internodes we notice a smooth cuticle and an epidermis with the outer cell-walls moderately thickened. The cortex consists of about twenty-five layers, of which the peripheral two or three are collenchymatic, the others thin-walled and starch-bearing. No endodermis was to be observed, and the mestome-bundles possess only a weak support of stereome, which does not form a continuous ring around these. It is merely represented by a few, one to two, layers on the inner face of the mestome-bundles or on the sides of these; on the leptome-side this tissue is, also, poorly developed, sometimes entirely wanting.

The structure of the mestome-bundles is very irregular. They are apparently arranged in one or two circles, but several of these having fused together so as to form several groups of leptome and hadrome in immediate connection with each other, their number or real position could not be ascertained. As will be seen later, the mestome-bundles of the stem above

ground are leptocentric, and this structure is, also, to some extent to be observed in the rhizome, but much less regularly; the following variations were noticed. A few were collateral with the leptome and hadrome radially opposite each other and supported by stereome on both faces, the outer and the inner. Or the leptome was found to be surrounded by the vessels on the sides, and these bordering again on other groups of leptome with or without some support of stereome; in others the leptome constituted but one group with some vessels on the sides, while inwards it was separated from the pith by layers of stereome. Near the periphery of the cortex were observed two isolated, collateral and, in transverse section, orbicular mestome-bundles.

The central portion of the rhizome is occupied by a thin-walled, starch-bearing, solid pith.

A much more regular structure exists in the short, vertical internode below the uppermost of the three scale-like leaves which surround the base of the flowering stem. In this internode the fourteen mestome-bundles are located in an almost regular circle; nine of these are leptocentric and much larger than the remaining five, which are collateral and orbicular in transverse section. In regard to the disposition of these two forms of mestome-bundles, there is usually a small one between each two of the larger ones. They all are surrounded by stereome and separated from each other.

#### *The stem.*

A like structure was observed in the long internode of the stem above ground. This stem-portion is cylindric and solid; the cuticle is wrinkled and covers a small-celled epidermis, which is moderately thickened, perfectly glabrous and almost destitute of chlorophyll. The cortex consists of about fourteen strata of which the peripheral three or six are collenchymatic, and the innermost layer did not show the characteristic structure of an endodermis. A circle of thirteen mestome-bundles is imbedded in the cortex; each of these are completely surrounded by two to three layers of moderately thick-walled stereome, which enters into the leptome as a separate group in the larger bundles or merely as a bridge in the smaller ones (fig. 1). The mestome-bundles are all more or less oval in transverse section and contain a very large group of small-celled leptome, completely surrounded by a ring of scalariform and spiral vessels.

A pith of large, thin-walled cells without starch occupies the center of the stem.

By continuing our investigation to the structure of the axis of the inflorescence, we notice here the same arrangement of the tissues, but the structure is somewhat weaker. There is

only one peripheral layer of collenchyma and the stereome is reduced to a few isolated cells on the leptome-side instead of forming a closed ring around the bundle. The mestome-bundles themselves occur in a smaller number, from eight to nine, and are strictly collateral; they border on a narrow cen-

1

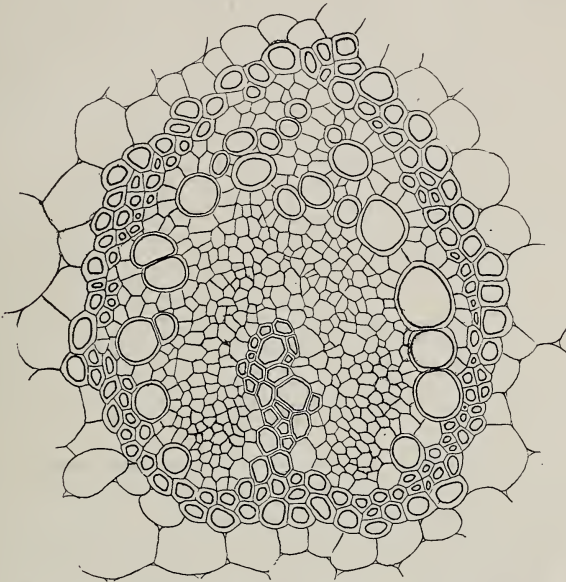

FIG. 1. Transverse section of a mestome-bundle from the stem above ground; 500 × natural size.

tral cylinder of pith. A corresponding structure is to be observed in the peduncle of the flower, but this possesses only two mestome-bundles, both of which are collateral.

#### *The leaf.*

The petiole: About three almost continuous, subepidermal layers of collenchyma surround the thin-walled cortex in which only a small amount of chlorophyll was observed. There is no stereome and no endodermis is differentiated. Seven collateral mestome-bundles traverse the petiole; they are arranged in a crescent corresponding with the outline of the petiole, and the mediane is the largest.

The blade: A thin smooth cuticle covers an epidermis with the outer cell-walls slightly thickened on both faces of the leaf-blade; the stomata are level with the epidermis and they are not parallel with the longitudinal axis of the blade; they occur only on the lower face. The chlorenchyma consists of five homogenous layers of oblong cells, which are not perpendicular, however, on the leaf-surface; this tissue is a little more

open on the lower face, thus representing some kind of pneumatic tissue. No stereome is developed, but there is a prominent ridge of colorless tissue above and below the midrib and the larger secondaries which becomes collenchymatic where it borders on the epidermis. But this is the only mechanical tissue in the leaf. The mestome-bundles are all collateral and single.

Characteristic of *Croomia pauciflora* is, thus, the structure of the mestome-bundles in the stem above ground, being leptocentric as well as in the rhizome, but simply collateral in the axis of the inflorescence, in the peduncles and in the leaves. The presence of similar leptocentric mestome-bundles is, moreover, characteristic of the genus *Roxburghia* in accordance with Mr. Lachner-Sandoval's investigations, cited above. This peculiar structure, where the leptome is surrounded, more or less completely, by the hadrome, is well known from various other orders among the Monocotyledones, but mostly from the rhizomes of these\*; it is known, also, from mestome-bundles of certain Dicotyledones, which are located in the pith. In other words, it seems as if this peculiar structure of the mestome-bundles is principally observable in storage-organs and tissues: rhizomes and pith. But in the *Roxburghiaceae* this structure is, furthermore, met with in the stem above ground instead of only in the rhizome.

Another peculiarity is the presence of stereome in the leptome, sometimes as an isolated group in the larger mestome-bundles or as a bridge in the smaller ones. The occurrence of thick-walled cells in the leptome has been described by several authors and defined as an abnormal thickening of the companion cells or, in some instances, of the sieve-tubes themselves instead of pertaining to the adjoining strata of stereomatic tissue. However it has been admitted that it is only occasionally that such thick-walled cells in the leptome are clearly distinguishable from true stereome-cells. In *Croomia*, as far as the writer has been able to ascertain, these cells were inseparable from the supporting layers of stereome; thus we have described them as belonging to this tissue.

It appears as if leptocentric mestome-bundles in stems above ground are uncommon, at least among the Monocotyledones. No such case has, so far, been recorded in the voluminous literature dealing with *Gramineae* and *Cyperaceae*, and Mr. Schulze does not mention the occurrence of such structure in any of the *Liliaceae*, *Hæmodoraceae*, *Hypoxidæ* or *Velloziaceae*, which he has studied and described in his interesting paper on these orders.†

Brookland, D. C., April, 1905.

\* Compare Chrysler, M. A.: The development of the central cylinder of *Araceae* and *Liliaceae* (Bot. Gazette, vol. xxxviii, p. 161, 1904).

† Engler's bot. Jahrb., vol. xvii, p. 295, 1893.

ART. VII. — *The Relative Proportion of Radium and Uranium in Radio-active Minerals*; by E. RUTHERFORD and B. B. BOLTWOOD.

THE experiments made by one of us\* have shown that within the limit of experimental error the amount of radium present in radio-active minerals is proportional to the content of uranium. The amount of radium corresponding to each gram of uranium in a mineral is thus a definite constant which is of considerable practical as well as theoretical importance.

The proportionality between the content of uranium and radium in radio-active minerals strongly supports the view that radium is a decomposition product of uranium. According to the disintegration theory, the amount of radium per gram of uranium present in a mineral should be a constant whose value can be approximately deduced if the relative activity of pure radium and pure uranium is known.

In order to determine the amount of radium associated with one gram of uranium it is only necessary to compare the activity of the emanation produced by a standard quantity of pure radium bromide with that produced by a quantity of mineral containing a known weight of uranium.

In the experiments which are to be described, a standard solution of radium bromide was prepared from a specimen of radium bromide, which had been found experimentally by Rutherford and Barnes to give out heat at a slightly greater rate than 100 gram-calories per hour. The radium bromide was, therefore, probably pure. About one milligram of the salt was taken and weighed as accurately as possible on a balance. The weighing was confirmed by comparing the relative gamma-ray effect produced on an electroscope by the sample in question and the effect produced by a quantity of radium bromide weighing 23.7 milligrams. The determinates by the two methods were found in good agreement.

The known weight of radium bromide was dissolved in water and solutions were successively made up which contained  $10^{-2}$  and  $10^{-4}$  milligram of radium bromide per cubic centimeter. Of the more dilute solution a quantity equivalent to 1.584<sup>cc</sup> was carefully weighed out, transferred to a glass bulb having a capacity of about 100<sup>cc</sup> and diluted to a volume of about 50<sup>cc</sup> with pure, distilled water. The bulb was sealed and allowed to stand for about 60 days in order that the maximum quantity of emanation might accumulate. At the end of this period the emanation was completely removed by boiling the

\* Boltwood, *Phil. Mag.* (6), ix, 599, 1905.

solution and was transferred to an air-tight electroscope, in which its activity was measured. The observed activity corresponded to the emanation from  $1.584 \times 10^{-4}$  milligram of radium bromide, which was assumed to be equivalent to  $0.926 \times 10^{-4}$  milligram of radium.

The activity of the maximum or equilibrium quantity of emanation produced by the radium associated with one gram of uranium in a radio-active mineral was determined by the method which has already been described.\* The mineral chosen was a very pure sample of uraninite from Spruce Pine, N. C., containing 74.65 per cent of uranium.

The activity of the emanation from the standard radium bromide solution was equal to 24.24 divisions per minute. The activity of the emanation from 0.1 gram of the mineral was equal to 14.45 divisions per minute, corresponding to 193.6 divisions per minute for each gram of uranium present. These values indicate that *the quantity of radium associated with one gram of uranium in a radio-active mineral is equal to approximately  $7.4 \times 10^{-7}$  gram.* One part of radium is therefore in radio-active equilibrium with approximately 1,350,000 parts of uranium.

By the application of these numbers to the ordinary ores of uranium it is possible to determine their actual content of radium. Thus a high-grade pitchblende ore containing 60 per cent of uranium carries approximately 0.40 gram of radium, equivalent to 0.69 gram of radium bromide, per ton of 2,000 pounds. A low-grade 10 per cent uranium ore will contain per ton approximately 0.067 gram of radium, equivalent to 115 milligrams of radium bromide.

The amount of radium occurring with uranium is about the amount to be expected if uranium is the parent of radium, but a satisfactory comparison of theory with experiment is not possible until the relative activity of pure radium and pure uranium is more accurately determined. Experiments in this direction are in progress and the results will be given in a later paper. A method has been devised for determining in a radio-active mineral the proportion of the total activity due to the presence of uranium, radium and the other radio-active bodies. The results obtained lead to the conclusion that actinium is not a direct product of uranium in the same sense as is radium. An account of these experiments will be published later.

\* Boltwood, loc. cit.



ART. VIII.—*Side Discharge of Electricity*; by JOHN TROWBRIDGE.

THE installation of a large storage battery of 10,000 to 20,000 cells presents many interesting problems in regard to insulation; and modern theories of ionization receive great support from a study of the phenomena observed in the region surrounding the poles of the battery. There is a great probability of an invisible ionization which is constantly taking place between the earth and the battery.

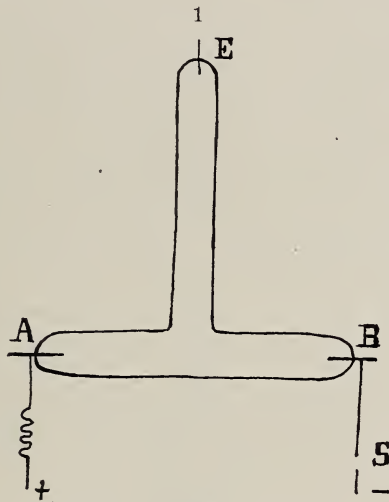

Such ionization immediately becomes visible in an interesting form of Geissler tube shown in fig. 1.

The terminal A is connected permanently with the pole of the battery through a large water resistance (several megohms). The terminal B is connected to the negative pole by a spark gap S. E is connected to the earth. At the instant the spark occurs a brilliant side discharge occurs between E and B. If the negative pole of the battery is permanently connected through the large water resistance to B, and A connected by a spark gap to the positive pole of the battery, the side discharge takes place between E and A. At the same time that these side discharges take place, a discharge passes between A and B. It is evident that the capacity of the region outside the battery, the room, and building charges up under the difference of potential between it and the poles of the battery, a difference

of potential which is greater than that between A and B, which are connected by the small resistance of the rarified gas.

This phenomenon suggests a photometric method of comparing the capacity of large condensers and also of obtaining the capacity of the immediately surrounding space. Fig. 2 represents a modification of the tube represented in fig. 1. To the arm C and D of the cross are attached the condensers which are to be compared. At the instant of the completion

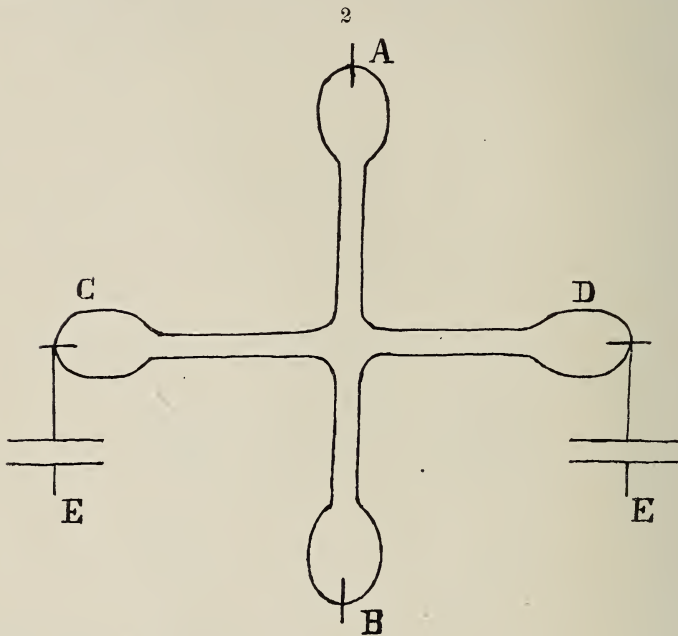

of the circuit with the storage battery under the conditions mentioned above, two side discharges take place from C and D either to A or B. By bringing the light of these two simultaneous discharges into a suitable photometric arrangement, one can compare the capacity of the condensers to the degree of accuracy obtainable by ordinary photometric determinations. Since it is difficult to obtain an estimate of the capacity of large bodies of irregular shape and of large extent, this method may be of use. By a suitable vacuum tube and proper exhaustion the method does not require a large number of cells.

It was noticeable that when a stratified discharge was established between A and B fig. 1, there being no spark gap in the circuit except that of the rarified space between A and B,

fluctuating feeble discharges took place to earth through E. This phenomenon seems to indicate a discontinuity in the stratified discharge.

When the small spark gap, either at the positive or negative pole, is of a suitable length, the discharges between E and either pole of the battery succeed each other so rapidly that the side discharges to earth appear continuous. If a large condenser is substituted for the earth at E, one plate of the condenser being connected to earth, the time between each discharge is lengthened. This time of charging can be well illustrated by connecting condensers directly through a large water resistance directly to the poles of a large storage battery and allowing the condensers to discharge through a spark gap. The time of discharge can be regulated through a wide range and the arrangement can be termed an electric clock.

It is probable that in the case of lightning side discharges take place to the earth in the manner indicated by this method; the potential between the positively and negatively charged clouds rising to a higher value than that between the clouds; the earth space beneath the clouds acting as a localized capacity.

ART. IX.—*The Effect of High Temperatures on the Rate of Decay of the Active Deposit from Radium*; by HOWARD L. BRONSON.

IN the course of a careful investigation of the decay of the active deposit from radium, some experiments of Curie and Danne\* were repeated. These consisted in determining the change which high temperatures produce on the rate of decay of this active deposit. As a result of the following experiments, a different conclusion from that offered by Curie and Danne has been arrived at.

Miss Gates† showed that high temperatures produced at least a partial separation of the components of the active deposit from radium, owing to the fact that they are not all equally volatile. Curie and Danne verified this, and also found that the rate of decay of the active deposit apparently was permanently altered by exposure to temperatures between 650° and 1300° C. The following table gives some of their results:

$t$	$\theta$
6 30°	29·3
8 30	24·6
10 00	21·0
11 00	20·3
12 50	24·1
13 00	25·4

Here  $t$  is the temperature in degrees centigrade to which the active deposit was raised, and  $\theta$  is the "period," that is the time in minutes required for the activity to fall to half value. From this table it is seen that the rate of decay increased as the temperature was raised from 650° to 1100°, but decreased again at still higher temperatures. Curie and Danne also stated that the decay curves were exponential, and they therefore concluded that the rate of decay had been permanently altered.

In the following experiments the measurements were all made with an electrometer, and the "constant deflection method" described by the writer‡ was employed. The active deposit was collected on platinum wires by connecting them to the negative pole of a battery of 400 volts, and exposing them for several hours in the emanation from radium. After removal the wires were kept for a few minutes at the desired temperature in a small electric furnace, made by Dr. C. A.

\* Comptes Rendus, cxxxviii, p. 748, 1904.

† Physical Review, May, 1903.

‡ This Journal, Feb., 1905.

Timme of Berlin, and were then placed in the testing vessel. A calibration curve for the furnace had previously been made by the use of a platinum-rhodium thermo-junction.

A large number of experiments were made using several temperatures between 700° and 1100° C. An example of the kind of results obtained is given in fig. 1. A, B, C and G are four decay curves of the active deposit, which had been previously heated to about 800° C. In the case of D, E and F the temperature used was about 900° C. The time is reckoned from the removal of the wire from the

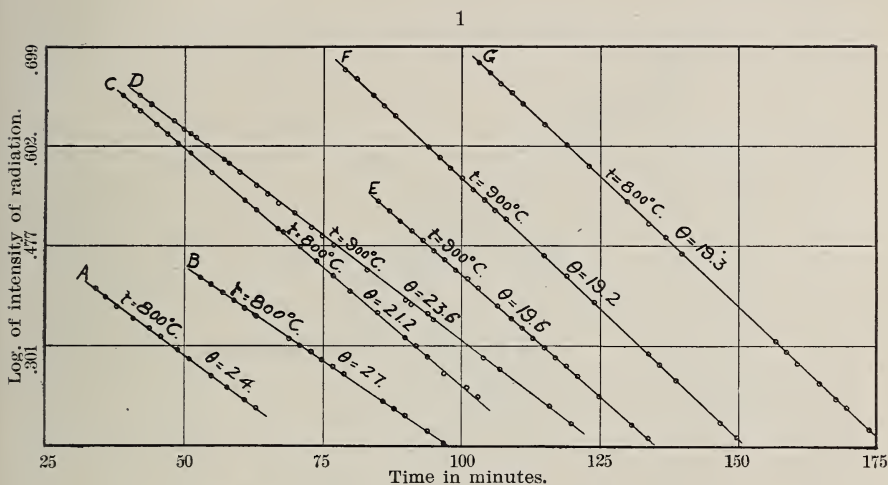

emanation. The first points on curves F and G should be at about 200 and 300 minutes respectively, as in these cases the wires were not placed in the furnace until several hours after their removal from the emanation. These curves are apparently exponential, as was found by Curie and Danne, but  $\theta$  does not at all seem to be a function of the temperature, for its value seems just as liable to change when the temperature is kept the same as when a different temperature is used. In fact  $\theta$  was found liable to take on any value between nineteen and twenty-seven minutes, and this was true for all temperatures between 700° and 1100°. Among these values of  $\theta$  there were, however, a large number between nineteen and twenty-one minutes. This was nearly always the case when the wire was not heated until several hours after removal from the emanation.

Now Rutherford\* has shown that, neglecting the first half

\* Philosophical Transactions, 204, p. 196.

hour, the decay curve of the active deposit from radium is satisfactorily explained by assuming two successive products, radium B and radium C; the matter B giving rise to no rays, and the matter C to  $\alpha$ ,  $\beta$  and  $\gamma$  rays. Taking twenty-eight minutes as the decay period of one of these, he calculated that the period of the other must be twenty-one minutes. Theoretically it makes no difference whether the longer period belongs to the matter B or C, but the above mentioned experiments of Curie and Danne supplied the evidence which decided this question in favor of the matter C.

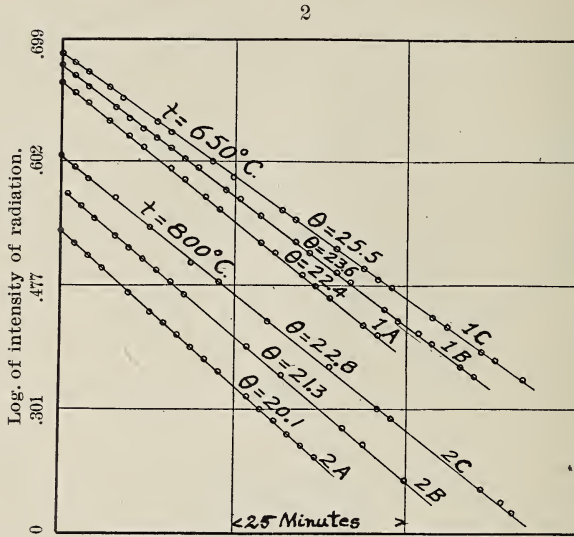

The fact that so many of the values of  $\theta$ , obtained after heating the deposit, were in the neighborhood of twenty-one minutes, made it seem quite possible that the matter C had the shorter period, and not that its period had been changed by heating. Also the fact that the rayless change in the active deposits from thorium and actinium each have a longer period of decay than the change immediately following, possibly is evidence in the same direction. If this be the case, then all the larger values of  $\theta$  must have been produced by mixtures of the two kinds of matter, B and C, in different proportions. This, however, would not give an exponential decay curve, but the period would continue to increase, since the ratio of the matter having the longer period to that having the shorter would increase with the time.

In order to see if this were the case, the decay of the activity of the heated deposit was measured over a long period of

time. Fig. 2 shows the result of two experiments of this kind. 1 A, 1 B and 1 C are three sections of the same curve, obtained after heating the active deposit to about 650° C. 1 A was taken immediately after heating, 1 B after about two hours, and 1 C after about four hours. The respective values of  $\theta$  were 22.4, 23.6, and 25.5. In the case of curve 2, the temperature used was about 800° C. 2 A was taken immediately after heating, 2 B after about one hour, and 2 C after about

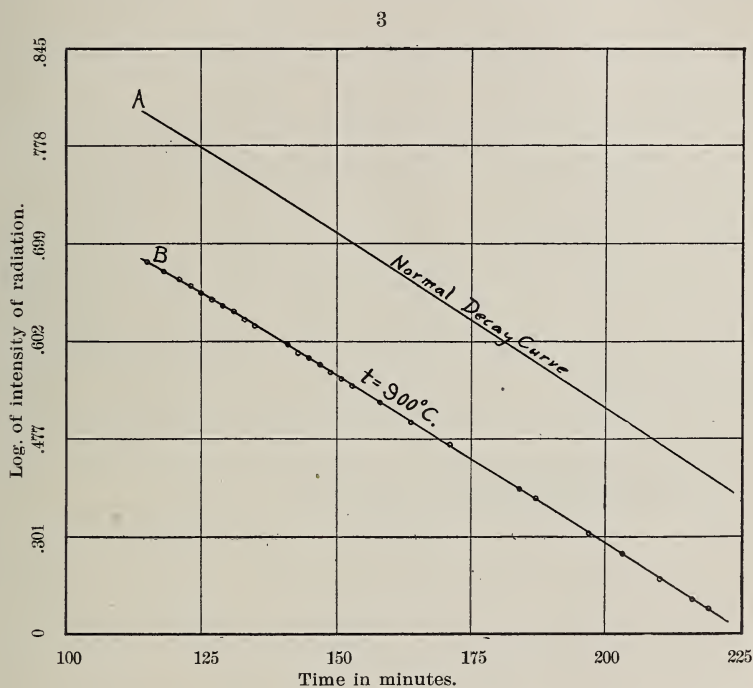

two and one-half hours, and the values obtained for  $\theta$  were, respectively, 20.1, 21.3, and 22.8.

The above results furnished very strong evidence in favor of the supposition that the heating did not actually alter the rate of decay of the active deposit. In order to make this conclusive, the wire on which the active matter had been deposited was sealed, before heating, in a piece of glass combustion tubing. This prevented the escape of any volatile products, which in the previous experiments had evidently been the uncertain factor. By exhausting the glass before sealing, it was found that it would stand temperatures high enough to melt the copper wires, which were used in this case.

A number of experiments were made in this way, using the same temperatures as before, but in no case did  $\theta$  fall below twenty-six minutes.

B, fig. 3, is the logarithmic decay curve, obtained when the active deposit was sealed in a glass tube and heated to  $900^{\circ}$  C. A is the normal decay curve for the active deposit. These curves are approximately parallel, showing that the rate of decay had not been measurably changed by a temperature of  $900^{\circ}$  C.

It is thus evident that temperatures between  $700^{\circ}$  and  $1100^{\circ}$  C. have very little, if any, effect on the rate of decay of the active deposit from radium. The results obtained by Curie and Danne and those given in the present paper are satisfactorily explained by assuming that radium C has the shorter instead of the longer of the two periods, and that radium B is the more volatile, but that in general a part of it still remains on the wire after heating.

The measurements made in this investigation also seem to show that both twenty-eight and twenty-one minutes are too large for the decay periods of radium B and C, and that twenty-six and nineteen minutes are nearer right. Experiments are at present in progress which it is hoped will settle this definitely.

In conclusion, I desire to thank Professor Rutherford for his many suggestions and kind supervision of this work.

Macdonald Physics Building,  
McGill University, Montreal, June 5, 1905.



## SCIENTIFIC INTELLIGENCE.

## I. CHEMISTRY AND PHYSICS.

1. *Amounts of Neon and Helium in the Air.*—SIR WILLIAM RAMSAY, in connection with previous investigations, has roughly estimated the amount of helium in the atmosphere at one or two parts per million, and the amount of neon at one or two parts per hundred thousand. He has now made more accurate determinations of these constituents, and finds one volume of neon in about 81,000 volumes of air, or .00086 per cent by weight, and one volume of helium in about 245,000 volumes of air, or .000056 per cent by weight. (In the published article the percentages are erroneously given as 100 times smaller than the above.) The method used in these determinations was based upon the absorption of gases by charcoal as recently studied by Sir James Dewar. The charcoal was kept at  $-100^{\circ}$ , at which temperature neither neon nor helium is absorbed in appreciable quantities, while the other constituents may be almost completely absorbed by repeating the treatment. In this way about  $2^{\circ}$  of gas were left from the treatment of 18 l. of air, and after the residual air had been removed by sparking, the residue, which gave no spectrum of argon, was measured in a delicate apparatus. The neon was then condensed by charcoal at the temperature of liquid air in order to separate it from helium as far as possible, and the separate gases were afterwards measured. It appeared that this separation was a satisfactory one, although not absolute, and that the helium determination may be somewhat too high.

It is interesting to notice that Ramsay collected the lighter gases from  $540^{\circ}$  of liquid air, corresponding to about 400 l. of the gas, and that while he obtained a fair yield of neon and helium, he could find no evidence of the presence of hydrogen in this residue. The result appeared to show that there must be less hydrogen in the air than  $1/500$  of the combined neon and helium, but the author does not regard the experiment as quite conclusive.—*Chem. News*, xci, 203.

H. L. W.

2. *The Radio-activity of Thorium.*—An account is given by O. SACKUR of a product obtained by fractionating a mixture of barium and radium bromide obtained from 2.5 tons of thorianite. It was found by Hahn that the more soluble fractions of this mixture of bromides did not continually decrease in activity, as would be expected from the removal of radium, but, after a series of crystallizations, became more active. A strongly radio-active product was obtained from this liquid by precipitation with ammonia, and by solution in acid and precipitation with ammonium oxalate the activity was still further concentrated. It was found that the emanation from this substance lost one-half of its activity in 52–55 seconds, and that it consequently corresponds to the thorium emanation. This was confirmed by determining

the decay of its induced activity, which showed a period of 11.2 hours for the half value, while Rutherford has given about 11 hours as the characteristic period for the induced activity produced by the thorium emanation. It may be considered certain, therefore, that the substance obtained by Hahn gives off the thorium emanation; but, since comparative tests showed that the product possesses a power of emanation about 250,000 times greater than thorium, it is concluded that it contains a new radioactive element which produces the thorium emanation. The question arises whether two distinct elements may produce the same emanation, or whether the activity of thorium may be due to a mixture with this new element—a question which has not yet been decided.—*Berichte*, xxxviii, 1756. H. L. W.

3. *The Use of Quartz Apparatus for Laboratory Purposes.*—MYLIUS and MEUSSER of the Phys.-Techn. Reichsanstalt at Charlottenburg have investigated the action of various liquids upon quartz vessels by finding the loss in weight after such action. They find that water has no appreciable effect either at ordinary temperature or at 100°. In fact, the electrical conductivity of water may be diminished by boiling off the carbonic acid in these vessels. The vessels are attacked by alkaline liquids, and in this respect they appear to possess no advantage over glass. Dilute acids, with the exception of hydrofluoric, and concentrated sulphuric acid have no appreciable action at 100°, or at lower temperatures. Corrosion is produced by phosphoric acid when it is concentrated above 400°, and white silicophosphate separates. Quartz vessels possess the property of absorbing certain dyes from their solutions. The amounts thus absorbed are exceedingly small, forming a uniformly colored film when the vessels are rinsed, and this can be removed by the use of hot solvents.—*Zeitschr. Anorgan. Chem.*, xlv, 221. H. L. W.

4. *Permeability of Quartz Vessels to Gases.*—It has been observed that vessels of quartz glass are permeable to helium at temperatures below red heat, and BERTHELOT has recently found that other gases, for instance, atmospheric nitrogen, are capable of penetrating tubes of this material at a temperature of about 1,300°. This property of fused quartz will somewhat limit its applications for investigations at high temperatures.—*Comptes Rendus*, cxl, 821. H. L. W.

5. *Outlines of Inorganic Chemistry*; by FRANK AUSTIN GOOCH and CLAUDE FREDERIC WALKER. 12mo, pp. xxiv + 233 + 514. New York, 1905 (The Macmillan Company).—This textbook of elementary chemistry, a large and comprehensive work, is divided into two distinct parts, "inductive" and "descriptive." About twice as many pages are devoted to the latter part as to the former. It has been the aim of the authors to introduce the student to chemistry by consideration of the simplest and fewest things, and much attention has been paid to the inferences to be drawn from experimental phenomena. Part I takes up the consecutive experimental development of the principles upon which

chemistry rests. Only in the final chapter of this part is the notion of the atom introduced. Part II is arranged in accordance with a modification of Mendeléeff's Periodic System. Graphic symbols are freely used, and ionic terminology has been employed, although the extreme developments of the idea of free ions have not been made use of. Careful introductions to group characteristics, and full summaries covering the relations in detail, are given in this part of the book.

H. L. W.

6. *Spectroscopic Analysis of Gas Mixtures.*—Many investigators have endeavored to use the sensitive portion of the positive discharge in a Geissler tube as a qualitative means of determining proportions of gases in mixtures. Secchi, however, found that oxygen of air could not be detected in this way. E. Wiedemann has shown that mercury vapor masks the hydrogen and nitrogen spectra even when a large proportion of these gases are present. Collie and Ramsay found the method inoperative in the case of some gases. J. E. LILIENTFELD, by suitable forms of tubes and proper arrangement of electrical circuit, finds that the method can be made extraordinarily sensitive, and gives the following table :

Smallest visible quantities.	Collie and Ramsay.	E. Wiedemann.	Lilienfeld.
He in N	10%	--	0.7%
Ar in N	37%	--	0.932%
			(in air)
N in Hg	--	approx. 30%	0.7%
H in Hg	--	" 30%	0.7%

The author shows that the theory of ionization explains the masking of the spectra of gases in a mixture. The presence of one gas prevents the dissociation of another gas.—*Ann. der Phys.*, No. 5, 1905, pp. 931-942. J. T.

7. *The FitzGerald-Lorentz Effect.*—FitzGerald and Lorentz, in reference to Michelson and Morley's experiments on the drift of the ether, suggested that the dimensions of the apparatus might be modified by its motion through the ether. Professors MORLEY and MILLER have, therefore, taken up the experiment anew and conclude their paper as follows: "We may declare, therefore, that the experiment shows that if there is any effect of the nature expected, it is less than the hundredth part of the computed value. If pine is affected at all, as has been suggested, it is affected to the same amount as sandstone. If the ether near the apparatus did not move with it, the difference in velocity was less than 3.5 kilometers per second, unless the effect on the materials annulled the effect sought. Some have thought that the former experiment only proved that the ether in a certain basement room was carried along with it. We desire to place the apparatus on a hill covered only with a transparent covering, to see if an effect could be there detected." The authors propose to make this experiment.—*Phil. Mag.*, May, 1905, pp. 680-685. J. T.

8. *The Normal Element.*—The weighty questions in regard to the conditions of stability of the mercuric sulphate do not appear to be solved. At present the silver voltameter is as reliable as the Weston element, and there does not appear any reason why those countries which have adopted the silver voltameter as a standard should give it up for the Weston element.—*Physk. Techn., Reichsanstalt, 1904.* J. T.

9. *Influence of Character of Excitation upon Structure of Spectral lines.*—If a Geissler tube is excited by electric oscillations, the fine spectral lines undergo a marked change, which is probably due to an increase of temperature arising from the electrical oscillations.—*Phys. Techn. Reichsanstalt, 1904.* J. T.

10. *On the Radio-active Minerals.*—In a paper upon this subject in the Proceedings of the Royal Society (A, lxxvi, 88–100) the author, R. J. STRUTT, summarizes his results as follows :

(1) The conclusion, that the amount of radium in a mineral is proportional to the uranium, is confirmed. The investigation of this point has brought to light the existence of uranium in some minerals not previously known to contain it, monazite, for instance.

(2) It is shown that thorium minerals invariably contain the uranium-radium combination. The observation is difficult to interpret, but it may possibly indicate that thorium is producing uranium.

(3) Helium never occurs except in very minute quantity unless thorium is present. The helium of minerals, therefore, is probably produced more by thorium than by radium.

(4) Thorium minerals vary much in emanating power. Some retain nearly all their emanation, others give off large quantities.

11. *On the Absence of excited Radio-activity due to temporary Exposure to  $\gamma$ -rays.*—This subject is discussed by J. J. Thomson and by H. A. Bumstead in brief articles published in the Proceedings of the Cambridge Philosophical Society, vol. xiii, part 2 (pp. 124, 125–128). Thomson says :

“Experiments were made to see if the radiation given out by metals could be temporarily increased by exposure to the radiation from radium. The method used was to measure the saturation current inside a closed metallic vessel, then to place a sealed glass tube containing 30 mg. of radium bromide inside the vessel and leave it there for times varying from one hour to ten days ; the radium was then removed and as soon as possible afterwards the saturation leak again measured ; experiments were made with vessels made of lead, brass, tin, but no increase in the saturation current attributable to exposure to the radium was ever detected. The measurement of the saturation current took at least five minutes after the removal of the radium, so that a very short-lived increase might escape detection by this method.”

The last mentioned point was independently investigated by Bumstead, who experimented with copper, lead, tin and uranium nitrate by a method specially devised for the purpose, but also without positive results. The author remarks :

“With the four substances tested, therefore, the result is negative. If they retain the power of giving out any rays capable of penetrating 0.7<sup>cm</sup> of air and 0.00005<sup>cm</sup> of aluminium, for 0.009 seconds after exposure to the  $\beta$ - and  $\gamma$ -rays from 30 milligrams of radium, these rays must be considerably less intense than those due to a layer of uranium salt whose surface-density is 1 milligram per square centimeter.”

12. *Handbuch der Spectroscopie*; von H. KAYSER. Dritter Band. Pp. viii, 604; 3 plates, 94 figures. Leipzig, 1905 (S. HIRZEL).—Upon the appearance of the first volume of this work on Spectroscopy by Professor Kayser, a somewhat extended notice was published in this Journal, giving an outline of the whole plan (see vol. x, 464, 1900). Since then the second volume has appeared, followed now by the third. So thorough and exhaustive, however, is the work which the author is doing, that it has been found necessary to enlarge the original plan and devote two volumes instead of one to the subject of absorption, here discussed. The present volume contains the description of methods and of apparatus for the investigation of absorption spectra, a discussion of our present knowledge in regard to the connection between absorption and the constitution of the substance; and, finally, a presentation of the results of observations both for inorganic and artificial organic substances. The remainder of the subject, reserved for the next volume, includes the discussion of the natural organic coloring materials, both vegetable and animal, and also the phenomena connected with absorption; that is, dispersion, fluorescence and phosphorescence. The devotion with which the author has given himself to the subject and the thoroughness of his treatment of the entire subject matter are both noteworthy. In the preparation of the first volume he has had the assistance of Professor W. N. Hartley, of Dublin, who discusses very fully the question of the connection between constitution and absorption, where the author regarded himself as not sufficiently informed in reference to the chemical side to enable him to handle it satisfactorily. It needs hardly to be said that this chapter (pp. 144–316) shows the same degree of completeness and careful handling which characterizes the whole work.

## II. GEOLOGY AND NATURAL HISTORY.

1. *United States Geological Survey, Charles D. Walcott, Director.*—Recent publications by the U. S. Geological Survey include the following:

FOLIOS: No. 120, Silverton Folio, Colorado. This includes a description of the Silverton Quadrangle by WHITMAN CROSS, ERNEST HOWE and F. L. RANSOME; also geography and general geology of the Quadrangle by WHITMAN CROSS and ERNEST HOWE.

No. 121, Waynesburg Folio, Pennsylvania, by RALPH W. STONE.

BULLETINS. No. 243. Cement Materials and Industry; by EDWIN C. ECKEL. 395 pp., 15 plates.

No. 255. The Fluorspar Deposits of Southern Illinois; by H. FOSTER BAIN. 75 pp., 6 plates.—This bulletin gives an account of the fluorspar mines in Hope and Hardin counties in the extreme southern part of Illinois. The principal mines are near Rosiclare, Elizabethtown and Cave-in-Rock on the Ohio river in Hardin County. The discovery of the deposits goes back to 1839, although the material was not definitely mined until the early 70's. The author discusses the geology of the region in detail, and shows that the deposits of fluorspar, with the accompanying ores of lead and zinc, are vein deposits occurring along faulting fissures. The amount of fluorspar produced from the region in 1903 was 18,360 short tons, as compared with 29,000 tons from Kentucky and 628 from Arizona and Tennessee. The highest grade is used in the enameling, chemical and glass trades. The second grade is used in steel making, being used in open-hearth work because of the great fluidity which it gives the slag. Twenty thousand tons are used annually in this work. The lowest grade is used in foundry work, and there seems to be an almost unlimited market for it.

WATER SUPPLY PAPERS. No. 126. Report of Progress of Stream Measurements for the calendar year 1904. Prepared under the direction of F. H. NEWELL, by N. C. GROVER and JOHN C. HOYT. Part III, Susquehanna, Patapsco, Potomac, James, Roanoke, Cape Fear and Yadkin river Drainages.

No. 260, Contributions to Economic Geology, 1904; S. F. EMMONS, C. W. HAYES, geologists in charge. 620 pp., 4 plates, 25 figures.—The prompt and liberal return which the Geological Survey makes to the country at large for its pecuniary support is well shown by the numerous publications, appearing each year, which to a greater or less extent are devoted to Economic Geology. The publications of 1904 of this character, for example, included a Monograph by Van Hise; ten professional papers, chiefly on ore deposits in different regions; three bulletins and two folios, the last on the Globe and Bisbee Districts in Arizona. The present bulletin is the third bearing this title, its predecessors being Nos. 213 and 225, for the years 1902 and 1903. The object of these particular bulletins is to bring before the public, with all possible promptness, the economic results obtained by the Survey parties. Many of the subjects here presented are to be more fully discussed in other papers, appearing independently. The production of gold and silver are naturally presented at length; also that of tin, copper, zinc, lead and iron. Special chapters are given to some of the rare elements, as molybdenum, vanadium and uranium in Utah, etc. Coal, oil, gas and salt also form the subjects of special chapters. Many different authors contribute to the volume.

2. *Preliminary Report on the Geology and Underground Water Resources of the Central Great Plains*; by N. H. DAR-

TON. 433 pp., 4to, 72 plates, 18 figures. U. S. Geological Survey, Professional paper 32.—The area covered by the discussion in this volume embraces nearly all of South Dakota, Nebraska and Kansas, and extends westward to central Wyoming and Colorado. Over most of the region the rolling plains of the eastern portion rise gradually and uniformly to the westward. The geological structure is comparatively simple for the most part, with the exception of the Black Hills region in South Dakota and portions included of the Big Horn and Laramie Ranges in Wyoming and Colorado. The geological features are very fully presented in the first half of the present volume, the descriptions being based upon work by numerous geologists in the past, supplemented by that of Mr. Darton and his assistants. Numerous excellent views from photographs, and also geological maps and sections, accompany the text. The chief interest of the investigation, however, lies in the question of water supply, which in many parts of the region is very deficient and must be supplemented where possible by artesian wells. Great numbers of these have already been sunk, many of them with excellent results, and the study that Mr. Darton has made so carefully of the region gives promise that still more will be accomplished in the future. Although the rocks of Cambrian, Ordovician, Carboniferous and Jurassic age are believed to underlie the entire area, almost no wells exist lower than the Cretaceous, and the water horizon of the Dakota sandstone is the most widely extended and the most useful. The author states that over a thousand deep wells have been sunk east of Missouri River most of which are from 500 to 1000 feet in depth and yielding a large supply of flowing water, most of which is used for irrigation. The aggregate flow from these wells is estimated to be about 7,000,000 gallons a day. From the Fox Hills-Laramie formation the supply is much more limited. The Tertiary deposits also yield useful wells, particularly in the Denver basin. Finally, the alluvial deposits of the Quaternary afford large quantities of water from limited depths (5 to 50 feet), while the tubular wells in east South Dakota and east Nebraska bring the water of the glacial drift mainly at the base of the till.

The great pressure under which the water exists is a point of much interest and shows that it must owe its origin to an altitude some thousands of feet above. Several wells in eastern South Dakota, for example, show surface pressures over 175 pounds to the square inch, and two are a little over 200 pounds; the latter indicating a pressure of 780 pounds at the bottom of the well. The theoretical hydrostatic pressure is, however, much diminished by the leakage of water to the east and south. Full details are given in the volume in regard to existing wells, and the work closes with a chapter upon the Economic Geology of the region, that is, the supplies of coal, oil, gas, salt, etc.

3. *Origin of the Channels surrounding Manhattan Island, New York*; by W. H. HOBBS. Bull. Geol. Soc. America, xvi,

pp. 151-182, plate 35.—The author has made a careful study of the data now obtainable in regard to the various channels around the Manhattan Island, with a view to deciding as to their probable origin. In 1881 the subject was discussed by J. D. Dana\* and their formation ascribed to the presence of belts of limestone whose erosion was believed to explain the topographic features. Hobbs, however, concludes that there is no sufficient evidence of a correspondence between the directions of belts of limestone, or dolomite, and those of the various channels; on the contrary, he regards them as owing their origin to lines of jointing and displacement. The account of Julien is appealed to, giving the location and orientation of the principal dikes on the island, which quite generally run along the direction of the avenues. Julien shows that the orientation of the drainage has been largely determined by the planes of fracture. Julien has also shown that, besides these, there is a system of cross faults nearly at right angles to the avenues, or, in other words, along the cross streets. Thus the fissure planes occupied by the dikes, and the perpendicular series often occupied by quartz lenses and pegmatite, both correspond very closely in their direction with the two series making up the main drainage system. The observations of the author also show that many of the most prominent joint-planes in the rocks of the island have the direction of the cross fissures, N60°W. He concludes that "the rôle of the dolomite in fixing the locations of the present channels would thus appear to have been a subordinate one, excepting in so far as the direction of its boundaries has been determined by its fissure planes."

4. *The Isomorphism and Thermal Properties of the Feldspars*. Part I, Thermal Study; by ARTHUR L. DAY and E. T. ALLEN, pp. 13-75. Part II, Optical Study; by J. P. IDDINGS, pp. 77-95. Plates I to XXVI. With an introduction by GEORGE F. BECKER, pp. 4-12. Publication No. 31 of the Carnegie Institution of Washington.—The first part of this volume gives the complete presentation of the results obtained by Day and Allen in their very important work upon the thermal relations of the feldspars. This is accompanied by a series of twenty-six beautiful plates illustrating the crystallization of the various compounds and the effect of very high temperatures upon them. An extended abstract of this paper has already been given in the number of this Journal for February, 1905 (pp. 93-142).

Part II gives the results of an optical study by Iddings of the series of lime-soda feldspars synthetically obtained by crystallization in open crucibles from fused constituents. In addition to the detailed description of thin sections of the individual compounds, a general summary is given which contains some points of so much importance in petrography that we quote largely from it:

"The results of these synthetical experiments agree closely in some respects while differing in others. They agree in general

\* This Journal, xxi, 25, 443; xxii, 313, 1881.



in the habit and arrangement of the crystals of the different feldspars produced, while differing in the size of the crystals of the various feldspars according to their composition. These results have an important bearing on the problem of texture and granularity in igneous rocks.

First, as to the habit of the feldspar crystals produced from solution of the feldspar constituents without admixture of other material. So far as can be determined by microscopical study of the sections, the crystals are in most cases blade-like in form; that is, they are elongated plates. They vary, however, from one extreme to another, being in some cases equidimensional plates of extreme thinness, in other cases prisms, elongated in one direction with the other two dimensions equal. The development of these forms takes place in feldspars of various compositions, and appears to be chiefly a function of the rate of crystallization and not of the chemical composition of the feldspar, except as this modifies the viscosity of the solution. It is not possible to recognize any fixed relation between the habit of the crystals and the composition of the feldspar. This is, of course, in accord with the well-known isomorphism of the feldspar group.

The common mode of crystallization in these preparations is that of spherulitic aggregations, more or less completely developed in spherical forms.

The elements of the spherulites are bundle- or sheaf-like aggregations of long, thin blades, which blades lie nearly parallel to one another in the middle or narrower part of the bundle, and diverge at the ends into fan-like or plumose forms. Several of these bundles or blades cross one another at the middle, and when there are a sufficient number of bundles, or when they diverge sufficiently, a completely spherulitic aggregation results.

In some cases a spherulite consists of bundles or prisms that extend uninterruptedly from the center to the outer margin, the rays of the spherulite being nearly straight. In other cases the spherulite is a composite of divergent bundles shorter than the radius, which have been added to one another as though new plumes had started from the ends of earlier ones.

In most cases the middle portion of the feldspar bundles consists of stouter crystals than the outer parts. It also appears that the middle portion is more prismatic, in certain cases somewhat cuboidal, the outer parts becoming delicately tabular. This, with the divergence in position, explains the spread of the outer part of the sphere. There is a great increase in the number of individual crystals in the outer portion of the spherulite, and in some cases the crystals also increase in size in the outer part.

The shapes of the crystals are due to the flattening of the crystal parallel to the second pinacoid (010), and its elongation parallel to the crystal axis  $a$ . The outlines of the plates appear to conform to traces of several pinacoids in the zone of the  $b$  axis, (001), ( $\bar{2}$ 01), ( $\bar{1}$ 01), (201), ( $\bar{3}$ 04), ( $\bar{2}$ 03), not all of these occurring together. It is quite probable that pinacoids in the zone of the  $c$  axis also may be developed, but they were not recognized.

Bladed forms in some cases prove to be aggregates of thin plates not strictly parallel to one another in the plane of flattening, so that the blade is curved and not straight in the direction of its longest axis.

In some spherulites the component crystals are prisms throughout, with no tabular flattening. The number of crystal prisms increases from the center of the spherulite outward by the development of new prisms at slightly divergent angles, in arborescent arrangement.

The most complex arrangements are produced by twinning and divergence combined, resulting in feather-like aggregates. Long, narrow, tapering blades in albite twins form a shaft, elongated parallel to the crystal axis  $a$ , on two sides of which diverge at a slight angle a double set of thin blades, like barbs. These consist of branched smaller blades or prisms, like barbules, the branch prisms having approximately the direction of the crystal axis  $c$ . The two sets in each "barb" are apparently related to one another as the halves of a manebach twin. The small prisms are composed of many subparallel plates flattened in the plane of the second pinacoid (010). These correspond to barbicels in a feather.

With respect to the size of the crystals it is extremely significant that pure anorthite (An) develops in comparatively large plates, 5<sup>mm</sup> thick and 20 to 30<sup>mm</sup> long, in a few hours, whereas the more sodic the feldspar the smaller the individual crystals formed under almost the same conditions of cooling. Thus with oligoclase (Ab<sub>4</sub>An<sub>1</sub>) the individual crystals composing a bundle of blades are considerably less than 0.01<sup>mm</sup> thick, probably about 0.001<sup>mm</sup>, a difference in thickness when compared with anorthite of about 5,000 to 1. This as shown elsewhere is due to the greater viscosity of the liquid feldspars near their solidifying point as they approach the albite end of the series.

Any comparison of the grain of rocks, that is, the size of the constituent crystals, with a view to determining the physical conditions attending the solidification of the magma, must be based in the first instance on a knowledge of the behavior of the various rock-making minerals under similar physical conditions, both separately and in combination, that is, in solution with one another. The granularity of rocks is clearly a function of the chemical composition.

With respect to the homogeneity of the crystals separating from the liquid, it is observed that the great part of each crystal aggregation appears to be of one composition, but that in some cases a small proportion, probably less than 1 per cent, is different from the bulk of the feldspar, both in composition and habit. In one instance this small variant differed in composition but not in habit from the main mass of crystals.

In the first case it appears that crystallization began with feldspar richer in the anorthite molecule than the solution and developed cuboidal forms. These were prolonged into prismatic

bundles, the prisms having the composition of the main mass of crystals.

In the second case the small variant crystallized toward the end of the crystallization and contained more albite molecules than the main mass of feldspar crystals. It had the same habit as the other more calcic portion, and appears to have crystallized at the same time with it, the crystals with different optical properties being by the side of one another and not in zonal relation. Neither of the feldspars represents the end members of the series, An or Ab."

The Introduction to the volume by Becker, to whom the original plan of the work is largely due, will be read with much interest.

5. *The Tin Deposits of the Carolinas*; by J. H. PRATT and D. B. STERRETT. 64 pp. Raleigh, 1904. Bulletin No. 19 of the North Carolina Geol. Survey, J. A. Holmes, State Geologist.—The occurrence of tin in the country, and the southern states particularly, is mentioned in Bulletin No. 260 of the Geological Survey, noticed on page 70. This paper, by Pratt and Sterrett, appears from the North Carolina Geological Survey and takes up in detail the tin deposits of North and South Carolina. The first discovery of tin ore was made near Kings Mountain, North Carolina, in 1883, though but little progress was made until 1903, when the Ross mine at Gaffney, South Carolina, was discovered. During these twenty years, considerable prospecting has been done on the Carolina tin belt, so that this can now be traced quite definitely in a northeasterly direction from Gaffney, Cherokee county, South Carolina, across Gaston and Lincoln counties, North Carolina. Tin deposits also occur in Rockbridge county, Virginia.

A full account is given of the work which has been accomplished thus far, and a brief statement is added of the occurrence of tin in other parts of the country and abroad. At present, the practical work in the Carolina belt is limited to hydraulic mining in the alluvial gravels, the vein tin requiring different and more expensive treatment. Such deposits as those of the Ross mine are regarded as thoroughly remunerative, but in a large proportion of the alluvial deposits the yield of cassiterite is relatively small and this fact makes successful mining more problematical.

6. *Tubicolous Annelids of the Tribes Sabellides and Serpulides from the Pacific Ocean*; by KATHARINE J. BUSH, Ph.D. 8vo, 130 pp., 44 plates.—This admirable memoir forms part of volume xii of the reports of the Harriman Alaska Expedition. It includes a list of all known Pacific Ocean species of these groups and a very complete bibliography. The systematic portion includes full descriptions and illustrations of all the known species from California to Alaska. In the case of *Spirorbis* all the known species are reviewed from other regions also. Many of the illustrations are from photographs reproduced as heliotypes. The northwest coast of America seems to be one of the

great headquarters of the Sabellidæ, for the species are unusually large, handsome, and numerous. Many new genera and species are described and the previously known genera are revised.

A. E. V.

7. *A Student's Text-Book of Zoology*, Vol. II; by ADAM SEDGWICK. London: Swan Sonnenschen & Co. New York: Macmillan Co. 705 pp., 333 cuts.—The second volume of this excellent text-book has been received. It includes the true Vertebrata and Cephalochorda. These are treated with unusual fullness both systematically and anatomically, and are well illustrated, though a large part of the cuts are the same as those used in the well known work of Claus. About fifty cuts are new. In the case of fishes the somewhat old classification of Gunther has been followed. Many later improvements in that group might well have been adopted. On the whole, it is the best text-book on the morphology of the Vertebrata now available.

A. E. V.

8. *A Preliminary Report on the Protozoa of the Fresh Waters of Connecticut*; by HERBERT WILLIAM CONN. Bulletin No. 2, Connecticut State Geological and Natural History Survey. 69 pp., 34 pls., 1905.—This report deserves more than a passing notice because it is the first attempt yet made to enumerate and illustrate all the unicellular animals found in any locality in America. As implied by the title, the present report is but the beginning of an extensive work, in which it is aimed to eventually include a general study of all the Protozoa found in the State, with a consideration of their habits, evolution, geographical distribution, and their economic relation to the purity of drinking waters. The preliminary work for such a study must be the identification of the species, and to aid microscopists in recognizing the forms already found the present report is provided with 303 figures, all of which are from original drawings by the author from specimens collected in the State, and include every species which the author has thus far recognized in the region. No attempt has been made to give names to the new genera and new or unidentified species which are thus illustrated, such forms being designated merely as "new genus" and "sp. (?)" respectively. In the final report it is intended to furnish generic and specific diagnoses of all these forms, but the present work is provided with a brief description of the recognized genera only, specific descriptions being wholly omitted. There are admirably arranged keys to orders and genera. The figures are remarkably well drawn, and are printed in such a manner as to reflect great credit on the officers of the Survey, as well as on the author. The excellence of these plates is in striking contrast with the character of the illustrations published in the majority of State reports in recent years.

The value of this work will go far in justifying the inauguration of the newly established Geological and Natural History Survey of the State and forms a worthy leader of its series of zoological publications.

W. R. C.

9. *Études sur l'Instinct et les Moeurs des Insects*; by J.-H. FABRE. Souvenirs Entomologiques, 9<sup>e</sup> Série, pp. 374. Paris.—This ninth volume of the author's very interesting accounts of the domestic life of insects describes in popular language some of his extensive observations on the habits and instincts of several species of spiders, a scorpion, gall insects, etc. W. R. C.

10. *The Rocky Mountain Goat*; by MADISON GRANT. Reprinted from the 9th Annual Report of the New York Zoological Society. New York, Office of the Society, 1905. 36 pp.—A well illustrated account of the systematic position, habits, and distribution of this little-known game animal, which is not strictly a goat, but the sole American representative of the *Rupicaprinae*, or mountain antelopes. W. R. C.

11. *A Catalogue of North American Diptera (or two-winged Flies)*; by J. M. ALDRICH. 680 pp. Washington, 1905. Smithsonian Miscellaneous Collections, No. 1444, part of volume xlvi.—The author states that this work is based upon the second edition of Osten Sacken's Catalogue of North America Diptera, published in 1878. It is by no means a reproduction of this, however, for the twenty-five years that have passed since Sacken's Catalogue have doubled the number of species and otherwise brought many changes; the careful labors of the author, aided by many gentlemen interested in the subject, have brought all this material together into a valuable and homogeneous volume.

12. *The Fauna and Geography of the Maldive and Laccadive Archipelagoes*; by J. STANLEY GARDINER, M.A. Vol. II, Part IV, pp. 807-921, with plates lxvii-lxxxvii and text illustrations 127-139. Cambridge, 1905 (The University Press).—This continuation of the account of the collections made by the expedition of 1899-1900, repeatedly noticed in this Journal, contains the following reports: 1. The Alcyonaria of the Maldives, Part III, by Sydney J. Hickson. 2. Marine Crustaceans, XIV, Paguridae, by Major Alcock. 3. Hydroids, by L. A. Borradaile. 4. Notes on Parasites, by A. E. Shipley. 6. Marine Crustaceans, XV, Les Alpheidae, by H. Coutière.

Supplement I, pp. 923-1040, with plates lxxxviii-c and text-illustrations 140-153. This supplement contains the following reports: 1. Marine Crustaceans, XVI, Amphipoda, by A. O. Walker. 2. Madreporaria, III Fungida, IV Turbinolidae, by J. Stanley Gardiner. 3. Scyphomedusae, by Edward T. Brown. 4. Coleoptera, by D. Sharp. 5. The Cephalopoda, by W. E. Hoyle. 6. Notes in the Collection of Copepoda, by R. Norris Wolfenden.

13. *The American Museum Journal*. Published quarterly by the American Museum of Natural History, New York City.—The second number of volume v, "the Brontosaurus number," contains an account of the mounted skeleton put on exhibition in February, 1905. It also describes the two bird groups recently completed in the museum, one of Flamingos, the other of the summer bird-life of San Joaquin valley, California; the former is particularly striking and successful.

14. *Cold Spring Harbor Monographs*. Published by the Brooklyn Institute of Arts and Sciences, March, 1905.—The following additional numbers have been issued.

IV. The Life History of Case Bearers: 1, *Chlamys plicata*; by Ella Marion Briggs, 12 pp., with one plate and eleven text-figures.

V. The Mud Snail: *Nassa obsoleta*; by Abigail Camp Dimon, 48 pp., with two plates.

15. *Montana Agricultural College Science Studies; Botany*. Published quarterly by the College, Bozeman, Montana, 1905.—Numbers 1, 2 and 3 of volume i, 139 pp., issued together, contain the following papers:

I. A century of Botanical Exploration in Montana, 1805–1905, Collectors, Herbaria and Bibliography; by J. W. Blankinship.

II. Supplement to the Flora of Montana, additions and corrections; by J. W. Blankinship.

III. Common names of Montana Plants; by J. W. Blankinship and Hester F. Henshall. This is accompanied by an excellent colored plate of the pretty Bitter-root (*Lewisia rediviva*.)

### III. MISCELLANEOUS SCIENTIFIC INTELLIGENCE.

1. *Vom Kilimandscharo zum Meru*; von C. UHLIG. *Zeitschrift für Erdkunde*, Berlin, Jahrg. 1904, No. 9 und 10.—This preliminary account of a journey of exploration in German East Africa contains much that is of interest. In reading the opening pages one cannot help reflecting how greatly the task of exploration in eastern Central Africa has been simplified in the last two or three years by the opening up of the Uganda Railway. The long and trying journey across the eastern desert region, which exhausted so much of strength, energy and resources before the real work began, is now performed in comparatively few hours. Thus our author leaves the coast on the 12th of September, and nine days later with his caravan is at Moschi on the lower slope of Kilimandjaro, ready to commence the ascent.

This he made from the eastern side without apparently any serious difficulty beyond the suffering entailed by the sudden change from the tropics to an arctic region. It will be recalled that Kilimandjaro has two summit peaks, a higher snow-capped one to the west called Kibo, and a lower one to the east called Kimawenzi or Mawenzi; these are separated by a deep saddle. Uhlig reached a height of about 19,500 feet on Kibo, but was unable to attain the highest point, which was about 200 feet more above him. He gives a number of interesting details concerning the snow and glacier formations accompanied by excellent photographs. Since the last ascent by Hans Meyer the amount of ice and snow appears to have distinctly increased. One striking feature was the occurrence along the snow slopes of long processions of weird and bizarre-shaped figures several feet high, similar to those observed, of much greater size, in the Andes, and to which the name of "nieve penitente" has been given from the suggestion which they offer of processions of white-

robed penitents. Uhlig remarks that those he saw much more resembled trains of white poodles, rabbits and the snow men made by children than penitents. He ascribes their formation to the ablation from insolation and the dryness of the air, though other factors must be sought to explain their regularity of arrangement, as they appear in two distinct lines, one up and down the slope, the other at right angles, i. e. along contour lines. The mention of this arrangement by Uhlig suggests that perhaps cracking of the hardened snow into such systems, combined with the agencies mentioned above, may explain the phenomenon.

He also made a second ascent of Kibo from the south into the glacier zone and discovered a new one, not previously mapped, to which the name of Richter glacier is given. A fine photograph of Kibo from the south shows a great snow-covered dome with long glacial tongues reaching down from it.

After this work on Kilimandjaro, Uhlig turned his attention to Meru, a great volcano which rises to the westward. Its height is about 15,200 feet. His first ascent was made from upper Aruscha on the south flank, at an elevation of about 4,500 feet. At 7,000 feet a girdle composed of dense masses of bamboos was encountered, which lasted to about 8,800 feet, and which required the greatest efforts to penetrate. It appears quite similar to the bamboo zone which Gregory encountered on Mt. Kenia, and which he found so difficult to surmount. Above this the mountain offered no especial difficulties aside from the extraordinary steepness of its slopes. Towards its upper limit the flora assumes the distinctly alpine character noted on the other great volcanoes of equatorial Africa. Some forms of vegetation, grasses, compositæ and *Arabis albida*, persist even to the top. No snow was found on Meru, its summit falling over 2,000 feet short of the snow-line on the neighboring Kilimandjaro. Nor were any marks of a former period of glaciation visible, although on Kilimandjaro, according to Meyer, the glaciation once extended some 3,000 feet lower than at present, and Gregory found evidences of much more extended glaciation on Kenia than it now shows. It is possible, however, that Meru may have had small hanging glaciers.

At the summit Uhlig found himself on the edge of a vast crater, whose precipitous walls fell beneath him, over 4,000 feet to the bottom. The highest point, on the opposite wall, he attempted in a second ascent from the northeast, but was unable to attain.

Meru is a concentric crater which shows several periods of volcanic activity. There is an outward somma with broad opening to the east. Within this and close to it is an inner somma with a narrow opening to the west through it and the outer one. Within these is the deep caldera mentioned above with relatively level surface, on the south side of which and near the encircling wall, rises an ash cone which Uhlig believes to have very recently been in an active condition. The caldera is about one and a half miles broad.

Mügge, who studied the rock specimens brought back by Fischer\* from his journeys in equatorial Africa, found the sam-

\* Neues Jahrb. für Min., Beil. Bd. iv.

ples collected near the base of Meru to be of tephrite, leading to the suspicion that the volcano was built up of extrusive magmas of alkalic nature. This was fully confirmed by the material collected by Uhlig, the preliminary study showing it to consist of varieties of the phonolite-tephrite family. There is thus added another instance to confirm the highly alkalic character of the East African petrographic province, whose nature and extent through the studies of Hyland, Gregory, Prior, Lacroix and others, we are now beginning to appreciate. Now that the way has been opened into eastern equatorial Africa, we may expect that detailed studies of the region, such as Uhlig has been making in the Kilimandjaro region, will furnish in geography, in geology and in other fields of science, results of great importance and interest.

L. V. P.

2. *Glacial Studies in the Canadian Rockies and Selkirks.*—A paper upon the above subject, by W. H. SCHERZER, is contained in Part 4, Vol. II, of the Quarterly Issue of the Smithsonian Miscellaneous Collections. This gives an account of the results obtained in connection with the Smithsonian Expedition of 1904. It is made particularly interesting by a series of excellent illustrations reproduced from photographs. Many of the details of glacial structure are particularly well shown; as, for example, the Forbes "dirt bands," the "dirt stripes," the stratification and shearing exhibited in the glacial front, also the various forms of moraines under many different conditions.

3. *The Solar Observatory of the Carnegie Institution of Washington*; by GEORGE E. HALE. 22 pp. with 5 plates. Contributions from the Solar Observatory, Mt. Wilson, California, No. 2.—This second contribution from the Mt. Wilson Solar Observatory (see p. 473 of the June number) details the special objects aimed at in its construction and the particular lines of work which it is proposed to carry through. An account is given also regarding the erection of the Snow telescope, sent out by the University of Chicago, and also the progress made in the construction of other buildings. The present staff of the Observatory is as follows: Director, George E. Hale; Astronomer and Superintendent of Instrument Construction, G. W. Ritchey; and Assistants, Ferdinand Ellermann and Walter S. Adams.

4. *United States Naval Observatory, Rear-Admiral Colby M. Chester, U. S. N., Superintendent. Second series. Vol. IV, Appendix IV. The present status of the Use of Standard Time*; by EDWARD E. HAYDEN, Lieut. Commander, U. S. N. 28 pp. Washington, 1905.—This paper explains the use of "standard time" and shows the remarkable extension of this system over the world.

5. *Publications of West Hendon House Observatory, Sunderland. No. III, 1905. Pp. xi, 122, with 9 plates.*—This volume contains the results of an extended series of observations by Mr. T. W. Backhouse, upon certain variable stars, made during the years 1866-1904.



# MERELY A REMINDER

THIS PAGE is occupied by us merely as a reminder that the only concern in America which can supply you with

SPECIMENS IN ALL DEPARTMENTS OF NATURAL HISTORY

(Except Botany and Entomology)

IS

## Ward's Natural Science Establishment

To our old friends, the leading museums, colleges, educators and private collectors of the world, we are continually offering new things, some of which will be announced at the bottom of this page, from time to time. We endeavor to always remember you with our latest circulars; if you have failed to receive these recently, a line from you will bring them by return mail.

To those who have not formerly dealt with us,—our establishment was founded in 1862, and incorporated in 1890 as a stock company with a paid-up capital of \$125,000. We occupy a frontage of 250 feet facing the University of Rochester, and are known from the Yukon to the Ganges as the largest institution in the world dealing in Natural History Specimens. For over forty years we have made it our sole business to collect, prepare and sell these, individually or in collections. Quality rather than extreme cheapness is our aim, and we have spared no expense to maintain a high standard and a standing in scientific circles. We pay no commissions, but deal direct with our customers, and sell at list prices only. We offer school collections as low as \$5 and have made one cabinet costing over \$100,000 (Field Columbian Museum, Chicago), and seventeen others ranging from \$10,000 to \$70,000. In numerous instances we have built a large public museum complete at one stroke. Our catalogues, over twenty in number, are not mere price-lists, but are valuable as reference works, and have even been used as text-books in academies and colleges. A small charge is made for these, except to our regular customers or teachers intending to purchase; a list will be sent upon request. We also issue free circulars in all departments, and shall be glad to place your address on our mailing list.

### OUR DEPARTMENTS.

*Mineralogy* (Minerals, Rocks, Crystal Models, Meteorites, etc.).  
*Geology* (Phenomenal Series, Relief Maps, Geological Models).  
*Palaeontology* (Fossils, Casts of Celebrated Fossils, Wall Charts, etc.).  
*Archaeology and Ethnology* (Specimens, Models, Casts of Monuments).  
*Invertebrates* (Shells, Echinoderms, Corals, etc.; Biological Supplies).  
*Zoology* (Mounted Skins and Skeletons, Custom Work in Taxidermy).  
*Human Anatomy* (Human Skeletons, and Anatomical Models of all kinds).

### SPECIAL ANNOUNCEMENT FOR THIS MONTH.

**MASTODON.**—We have recently received an unusually complete skeleton which we are prepared to mount on order.

**GLYPTODON.**—A fine specimen of *Schistopleurum typum* has recently been restored and mounted by us.

**MOA.**—One of the largest specimens we have mounted is now ready for sale. Full particulars and photographs to interested parties.

---

Ward's Natural Science Establishment,

76-104 COLLEGE AVENUE, ROCHESTER, N. Y.

## CONTENTS.

	Page
ART. I.—Iodine Titration Voltameter ; by D. A. KREIDER .	1
II.—Handling of Precipitates for Solution and Reprecipitation ; by F. A. GOOCH .....	11
III.—Estimation of Sulphites by Iodine ; by R. H. ASHLEY	13
IV.—Revision of the New York Helderbergian Crinoids ; by M. TALBOT. (With Plates I-IV) .....	17
V.—Petrographic Province of Central Montana ; by L. V. PIRSSON .....	35
VI.— <i>Croomia pauciflora</i> ; by T. HOLM .....	50
VII.—Relative Proportion of Radium and Uranium in Radio-active Minerals ; by E. RUTHERFORD and B. B. BOLTWOOD .....	55
VIII.—Side Discharge of Electricity ; by J. TROWBRIDGE ..	57
IX.—Effect of High Temperatures on the Rate of Decay of the Active Deposit from Radium ; by H. L. BRONSON..	60

### SCIENTIFIC INTELLIGENCE.

*Chemistry and Physics*—Amounts of Neon and Helium in the Air, W. RAMSAY : Radio-activity of Thorium, O. SACKUR, 65.—Use of Quartz Apparatus for Laboratory Purposes, MYLIUS and MEUSSER : Permeability of Quartz Vessels to Gases, BERTHELOT : Outlines of Inorganic Chemistry, A. GOOCH and C. F. WALKER, 66.—Spectroscopic Analysis of Gas Mixtures, J. E. LILIENTELD : FitzGerald-Lorentz Effect, MORLEY and MILLER, 67.—Normal Element : Influence of Character of Excitation upon Structure of Spectral lines : Radio-active Minerals, R. J. STRUTT : Absence of excited Radio-activity due to temporary Exposure to  $\gamma$ -Rays, 68.—Handbuch der Spectroscopie, H. KAYSER, 69.

*Geology and Natural History*—United States Geological Survey, 69.—Preliminary Report on the Geology and Underground Water Resources of the Central Great Plains, N. H. DARTON, 70.—Origin of the Channels surrounding Manhattan Island, New York, W. H. HOBBS, 71.—Isomorphism and Thermal Properties of the Feldspars, A. L. DAY and E. T. ALLEN, 72.—Tin Deposits of the Carolinas, J. H. PRATT and D. B. STERRETT : Tubicolous Annelids of the Tribes Sabellides and Serpulides from the Pacific Ocean, K. J. BUSH, 75.—Student's Text-Book of Zoology, A. SEDGWICK : Preliminary Report on the Protozoa of the Fresh Waters of Connecticut, H. W. CONN, 76.—Études sur l'Instinct et les Moeurs des Insects, J.-H. FABRE : Rocky Mountain Goat, M. GRANT : Catalogue of North American Diptera (or two-winged Flies), J. M. ALDRICH : Fauna and Geography of the Maldive and Laccadive Archipelagoes, J. S. GARDINER : American Museum Journal, 77.—Cold Spring Harbor Monographs, 78.

*Miscellaneous Scientific Intelligence*—Vom Kilimandscharo zum Meru, C. UHLIG, 78.—Glacial Studies in the Canadian Rockies and Selkirks, W. H. SCHERZER : Solar Observatory of the Carnegie Institution of Washington, G. E. HALE : United States Naval Observatory : Publications of West Hendon House Observatory, Sunderland, 80.

VOL. XX.

AUGUST, 1905.

Established by BENJAMIN SILLIMAN in 1818.

THE  
AMERICAN  
JOURNAL OF SCIENCE.

EDITOR: EDWARD S. DANA.

ASSOCIATE EDITORS

PROFESSORS GEORGE L. GOODALE, JOHN TROWBRIDGE,  
W. G. FARLOW AND WM. M. DAVIS, OF CAMBRIDGE,

PROFESSORS ADDISON E. VERRILL, HORACE L. WELLS,  
L. V. PIRSSON AND H. E. GREGORY, OF NEW HAVEN,

PROFESSOR GEORGE F. BARKER, OF PHILADELPHIA,

PROFESSOR HENRY S. WILLIAMS, OF ITHACA,

PROFESSOR JOSEPH S. AMES, OF BALTIMORE,

MR. J. S. DILLER, OF WASHINGTON.

FOURTH SERIES

VOL. XX—[WHOLE NUMBER, CLXX.]

No. 116.—AUGUST, 1905.

NEW HAVEN, CONNECTICUT.

1905

THE TUTTLE, MOREHOUSE & TAYLOR CO., PRINTERS, 123 TEMPLE STREET.



Published monthly. Six dollars per year, in advance. \$6.40 to countries in the Postal Union. Remittances should be made either by money orders, registered letters, or bank checks (preferably on New York banks).

# CRYSTALLIZED STANNITE

A small consignment direct from the silver mines in Bolivia affords new and unique examples of the following. They have been identified by high mineralogical authority.

**Stannite, Splendent crystals**, grouped in cavities of the massive mineral. The crystals are most perfectly developed and very rich in planes. The species has been known to science for over a century, but until recently only in the massive form, thus leaving its crystallographic form in question. Hence the present find is peculiarly welcome.

**Andorite.** A silver and lead sulph-antimonide. Massive and in small but characteristic crystals of highly modified orthorhombic habit. Sometimes associated with the crystallized Stannite.

---

## RARE MINERALS

Specimens are supplied by us to students and chemists for purposes of comparison and investigation; in commercial quantities for industrial uses.

---

## SYSTEMATIC COLLECTIONS OF TYPICAL SPECIMENS

In sets of twenty-five up to fifteen hundred specimens. Prices \$5.00 upwards per set, the average price for students' specimens being about twenty cents. We have supplied the leading institutions for thirty years, having lately completed a single order for over 60,000 specimens. Our material is the accepted standard both as to correct labeling and high quality.

**Free Collection Catalog**, containing lists and illustrations of General Mineral Collections, Series of Ores for Prospectors, Sets of Crystals, Series illustrating Hardness and other Physical Characters of Minerals, with Price List of Laboratory Material and Individual Specimens.

---

## FOOTE MINERAL CO.,

Established 1876, by Dr. A. E. Foote.

W. M. FOOTE, Manager.

DEALERS IN

MINERAL SPECIMENS AND COMMERCIAL RARE MINERALS,

1317 Arch Street, Philadelphia.

T H E

# AMERICAN JOURNAL OF SCIENCE

[FOURTH SERIES.]

ART. X. — *On the Mechanical Equivalent of the Heat Vaporization of Water*; by R. H. HOUGH.

THE object of this investigation is the development of a method for the determination of the mechanical equivalent of the heat of vaporization of water directly in ergs: i. e., of a method not involving the use of the calorie.

This equivalent, which will be designated in what follows by  $L$ , is usually expressed in terms of the calorie varying from 536 C. to 540 C., depending on the particular calorie taken as the unit and the particular method pursued.

Regnault's is the only classic determination. He defined the calorie as the amount of heat to raise a kilogram of water from  $0^{\circ}$  to  $1^{\circ}$ , and worked out the following formula:

$$L = 606.5 - 0.695t - 0.00002t^2 - 0.0000003t^3$$

At standard pressure this gives the value 536.5, which is generally used by physicists, notably by Joly in the reduction of his determinations with the steam calorimeter. In close agreement with this value is the 536.2 of Berthelot, whose method was much less complicated. The empirical formula of Griffith:\*

$$L = 596.73 - 0.601t$$

gives the value 536.63 in terms of the calorie from  $14^{\circ}.5$  to  $15^{\circ}.5$  centigrade. This agreement is only apparent, and a more just value of  $L$  is obtained by following Callendar,† who estimated  $L$  from the observations of Joly and Barnes. Joly‡

\* Griffith, Phil. Trans. A., 1895, p. 261.

† Callendar, Proc. Roy. Soc., lxxvii, 1900.

‡ Joly, Proc. Roy. Soc., xlvii, 1889.

determined the mean specific heat of water from  $12^\circ$  to  $100^\circ$  in terms of the calorie at  $20^\circ$  using the following relation :

$$wL = Ws(t_1 - t_2)$$

observing  $w$ ,  $W$ ,  $t_1$ , and  $t_2$ , and taking Regnault's value of  $L$ , 536.5. Callendar substitutes in this relation Joly's observations of  $w$ ,  $W$ ,  $t_1$ , and  $t_2$ , and Barnes's\* determination of the mean specific heat of water from  $12^\circ$  to  $100^\circ$  in terms of the calorie at  $20^\circ$  and solves for  $L$ . This gives the value of 540.2 in terms of the calorie at  $20^\circ$ . Callendar prefers this value to that of Regnault and uses it in his work on the properties of steam. It is probable that even this value is low, since Barnes's† values for the specific heats of water from  $40^\circ$  to  $100^\circ$  are almost parallel to but much lower than those of Regnault. There is much uncertainty as to the value of  $L$  in calories.

There is as yet no absolute determination of  $L$  in ergs. It may be expressed in ergs, however, as the product of  $L$  in calories into the mechanical equivalent of heat. Using 540.2 as the most probable value of  $L$  in calories at  $20^\circ$  and  $4.184 \times 10^7$  as the most probable value of the mechanical equivalent at  $20^\circ$ , this being an average of the values due to Barnes, Rowland, Griffith, Schuster, and Moorby, gives  $2.26 \times 10^{10}$  against  $2.24 \times 10^{10}$  from Regnault's value.

The sources of error for this value are many. It can not be stated that the mechanical equivalent of the heat of vaporization of water is known with certainty to one per cent.

In any method of calorimetry involving the use of the calorie, no greater degree of accuracy can be attained than that of the calorie itself. But the determination of the value of  $C$  involves the use of the thermometer and all the errors incident to the measurement of temperature. That these are greater and more varied than is commonly supposed, and can only be corrected for by the exercise of the greatest care and skill, is definitely shown by Rowland‡ in his work on thermometry. He sees visions of careful, painstaking observers conscientiously reading with telescope and micrometer eye-piece to the thousandth part of a degree, unconscious of the fact that variations due to internal and external pressure, apparent friction and previous history, to say nothing of those due to the sectional calibration and the fundamental points, are many times as great as the usual errors of parallax and estimation.

Griffith,§ who is not so caustic though quite as vigorous, says: "The difficulties with regard to the measurement of temperature are not peculiar to the electrical method of inves-

\* Brit. Assoc. Rep., 1889.

† Phil. Trans. A., 1902, vol. cxvii.

‡ Rowland, Proc. Am. Acad. of Arts and Sciences, vol. xv.

§ Griffith, Phil. Trans., 1893.

tigation, and therefore I need not dwell upon them. I would, however, venture to add my expressions of astonishment to those of Rowland, that so many enquirers attach so little importance to this point: many investigators, whose methods have otherwise been of a high order of accuracy, having satisfied themselves with the mercurial thermometer as a standard." Rowland\* rejects, as having no weight, previous determinations in which the thermometer readings were not reduced to the air scale. As to the difficulty of this reduction, and to the general uncertainty of the apparent readings of the ordinary thermometer, a very instructive object lesson is to be found in an article by Cole and Durgan,† entitled "An Example in Thermometry."

It is the record of a systematic calibration of a Gerhardt thermometer, made in a concise and thorough manner. The mere statement of the corrections made, the record of the observations, and the results of the calculations, stated as briefly as consistency with clearness would permit, occupy twenty pages. In his determination of the mechanical equivalent of heat, Rowland made the most involved and elaborate corrections on his thermometer readings, and only brought his results and those of Joule into agreement by making the same kind of corrections for the latter's thermometers. Without raising the question of the soundness of such corrections, it is evident that a method for the determination of any fundamental heat constant independent of them is desirable if only to serve as a check: for the only way to minimize their effect is to extend the range of temperature, which is sure to increase the errors due to radiation, conduction and the calorimeter constant.

The error due to the latter constant need not be large, provided only that the water equivalent of the calorimeter be small compared with that of the substance under observation, and this can usually be accomplished without much difficulty.

The error due to the water vapor in the steam is only present in methods of steam calorimetry and is almost entirely eliminated by the differential method.

The errors due to radiation, convection and conduction are more serious. Reynolds‡ remarks on Joule's determination "that notwithstanding the greater facilities enjoyed by subsequent observers owing to the progress of physical appliances, the inherent difficulties remained: the losses from conduction and radiation could only be minimized by restricting the range of temperature and this ensured thermometric difficulties, par-

\* Rowland, Proc. Am. Acad., vol. xv.

† Cole and Durgan, Phys. Review, vol. iv, 1896.

‡ Reynolds, Phil. Mag., 1897.

ticularly with the air thermometer which does not admit of very close reading." In fact, so uncertain are the corrections for radiation and conduction, that Griffith\* asserts as "the general principle on which he proposed to work, that of eliminating the effects of radiation, conduction, etc., rather than that of ascertaining the actual loss or gain due to such causes." He eliminates these effects by maintaining the walls of the chamber enclosing his calorimeter at a constant temperature and gradually raising the temperature of the calorimeter from some point below to some point above that of the jacket, such that the gain and loss by the calorimeter are equal. This he calls the null point and determines it experimentally. The correction for convection by this method is doubtful. Rowland, who also bunches the losses due to radiation, convection and conduction, estimates the loss by convection to be more than 75 per cent of the total losses from these causes. He likewise corrects empirically. Obviously a better plan would be to eliminate not only the effects but the cause of these errors by maintaining the calorimeter, the jacket and the intervening medium at the same constant temperature, if a method admitting of such a process is possible. In fact, the principle of elimination of source of error is fundamental to all physical measurements since minimization and correction formulæ can never be more than a series of successive approximations.

The grounds then for a new method of determining *L* are: (*a*) the absence of any authoritative determination; (*b*) the absence of any absolute method; (*c*) the inherent sources of error in the present indirect methods. These are sufficient but there are weightier considerations: i. e. the advantages resulting from the use of *L* as the primary heat unit. Much can be said in favor of *L* instead of *C* as the primary heat unit, especially since the development of steam calorimetry by Bunsen and Joly.

The substance under calorimetric observation may be in a thermo-dynamic or in a thermo-static condition. The temperature may be changing, or it may be constant. In the first case the thermometer should be accurate, delicate and sensitive. That is to say, that not only should all corrections to reduce its readings to the air scale be definitely known, but it should respond to small variations of temperature in a readable degree and respond quickly. In this case the readings must be taken rapidly and are necessarily limited in number. In the second case the thermometer should be accurate and delicate but not necessarily sensitive to a higher degree. The readings may be taken more leisurely, with greater precision, and are only

\* Griffith, *Phil. Trans.*, 1893.



limited in number by expediency. It is apparent that methods necessitating observations of the first class are, other things being equal, inferior to those involving readings of the second class only. The determinations of Regnault, Joule, Rowland, Moorby, Griffith and Barnes all involve observations of the first class. In Joly's method of steam calorimetry, however, the temperature readings are made while the substance is in a state of thermal equilibrium which may be maintained almost indefinitely.\* In this respect his method is unsurpassed. An absolute determination of  $L$  substituted for the Regnault value used by Joly would enhance the value of his work many fold. His differential method is unquestionably the best general method of calorimetry yet devised, the use of an uncertain constant being, as Joly himself pointed out, its weakest point.

Barnes' curve for the heat capacity of water from  $0^{\circ}$  to  $100^{\circ}$  will never be changed much except, perhaps, by shifting the origin along the axis of specific heats. Rowland determined only a small portion of this curve, which from  $10^{\circ}$  to  $20^{\circ}$  is practically parallel to Barnes' but lower in value. Regnault determined the portion of the curve between  $40^{\circ}$  and  $100^{\circ}$ . It is also practically parallel to Barnes' but much higher. This indicates the presence of constant errors—but where? In this particular work the men are to be given almost equal weight. A constant error in Rowland's work, whose results agree among themselves most perfectly but for which he only claims an accuracy of two parts in a thousand, is hard to locate. It is possibly due to the sensitiveness of his thermometers not being great enough for observations on a substance in a thermodynamic condition. Regnault's constant error is likely due to several causes, including radiation, while Barnes' is possibly due to the position of his thermometers, as this is a source of error common to all continuous methods and very hard to eliminate or to correct for. In some preliminary work on the ratio of  $L$  to  $C$ , an attempt was made to develop a continuous method of steam calorimetry. It was abandoned for a time at least because the results, while agreeing very well among themselves, were found to be a function of the position of the thermometers placed in the ingoing and outcoming water. It would not be safe then to decide which of these curves, agreeing so well in all but their positions, is nearest to the true one. The substitution of the true value of the heat of vaporization of water in Joly's determination of the mean specific heat of water from  $12^{\circ}$  to  $100^{\circ}$  in terms of the calorie at  $20^{\circ}$ , would give a value by which Barnes' curve could be shifted. In this way much of the work of previous investigators in calorimetry

\* Joly, Proc. Roy. Soc., vol. xlvii, 1889.

would be enhanced in value. Hence an absolute determination of the mechanical equivalent of the heat of vaporization of water is a thing to be desired in itself.

The present method aims at the elimination of the errors due to thermometry, the calorimeter constant, the water vapor in the steam, radiation and convection, and a rigorous correc-

1

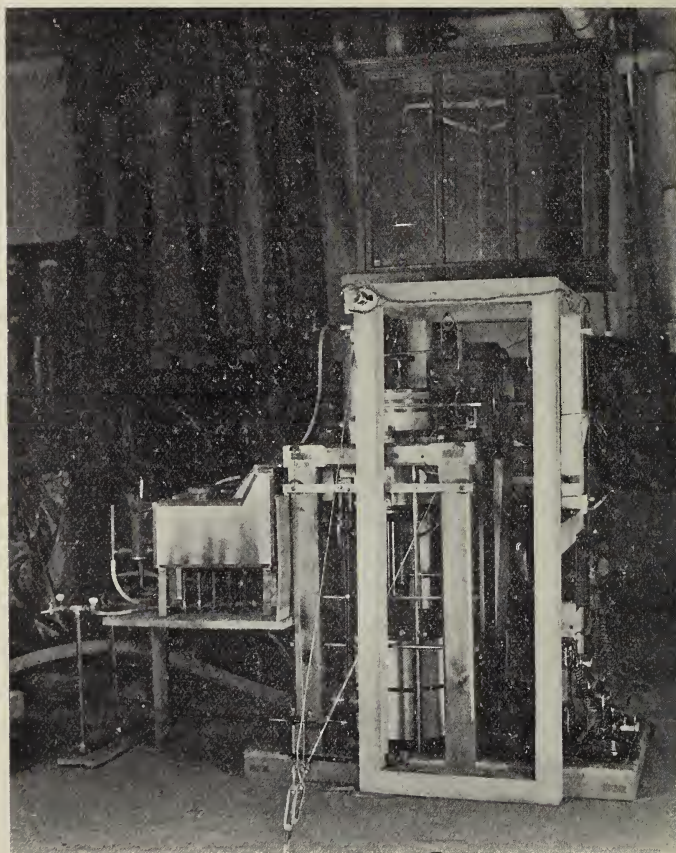

tion for conduction. The devices used to attain these ends will be described in detail followed by a discussion of the principles involved.

The general plan of the machine and the relation of its parts is best shown by the photograph (fig. 1) and the conventional diagrams (figs. 2 and 3). It consists essentially of (*a*) a vertical

shaft to which power is supplied: (b) a friction brake of peculiar design to convert the mechanical energy into heat: (c) a controlling device to maintain a convenient constant load: (d)

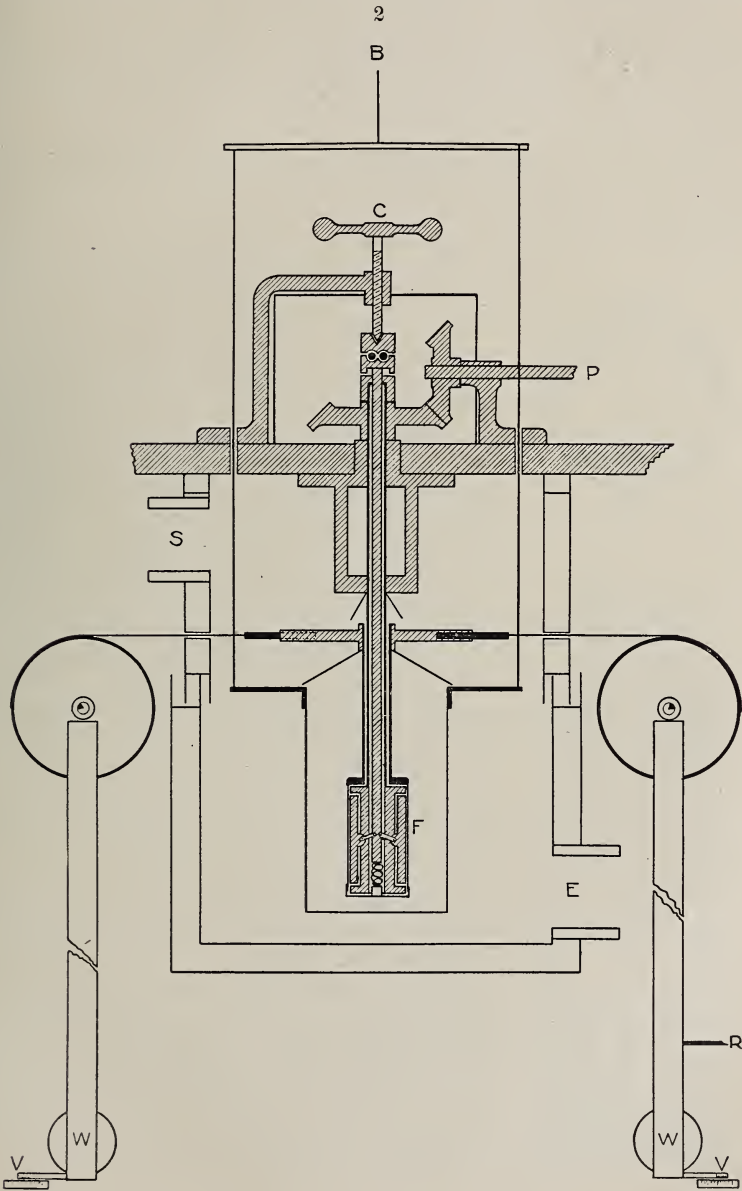

a cup suspended from the arm of a balance to hold the water to be evaporated: (*e*) two bent levers to balance the friction against gravity: (*f*) a recording device to plot the variation of the mechanical force with the number of revolutions: (*g*) a counter to register the number of revolutions: (*h*) a clutch for throwing the recorder and the counter in or out of gear at will: (*i*) a double-walled jacket: (*j*) a shield between the cup and the jacket to prevent radiation: (*k*) a steam supply to furnish the steam bath.

The vertical shaft consists of a hollow steel tube turned and fitted to accurately bored brass boxings. Power is communicated to this through the bevel gearing at the top from the horizontal shaft which is driven by a motor. To this horizontal

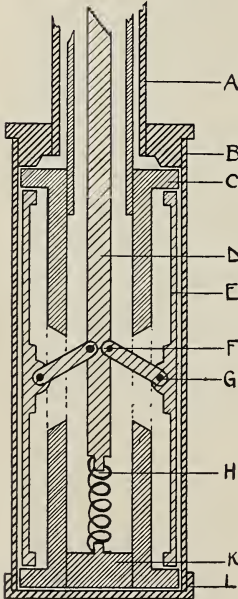
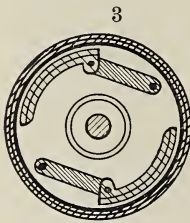

shaft is geared, through the clutch by which they are operated, the recorder and the counter. The counter is a Veeder and gives excellent service. The recorder consists simply of a horizontal drum whose angular velocity is a linear function of that of the brake. This carries the paper vertically under the marker. The marker is moved horizontally by means of the familiar device for parallel motion invented by Watt. The parts of this registering apparatus are very light and accurately centered on hardened steel cone bearings. They communicate directly with one of the bent levers so that the position of the marker at any instant is a linear function of the mechanical force. The marker is not in continuous contact with the paper, but only for an instant at regular intervals when struck by a bar which is actuated by a cam geared directly to the drum. The bent levers consist of accurately turned cast-iron pulleys with hardened steel knife edges bearing on hardened steel surfaces. Attached to these pulleys are pendulum bars and bobs. Flexible steel tapes with swivel joints transmit the moment from the disk of the friction brake to the pulleys of the bent levers. The friction brake consists of a bobbin threaded to the vertical shaft and rotating with it. Two rubbers, quadrant sections of a turned steel tube,

are hinged to the bobbin by means of a double joint which permits radial motion. A toggle joint, operated by a rod inside the vertical shaft, connects the two rubbers diametrically through an opening in the bobbin. This rod is forced upwards by means of a strong spiral spring in the bottom of the bobbin, and draws the rubbers in toward the center at the same time. When pressed down by the controlling device at the top, it forces the rubbers out radially. Surrounding the rubbers and accurately turned to fit them, is a cylinder supporting a torsion disk at the top. As the shaft rotates the rubbers move with it, and on account of the friction drag the cylinder and the torsion disk at the top with them. This motion is communicated by the tapes to the pulleys of the bent levers and the pendulums are displaced until their moment is equal to that of the friction. The double hinged joints are the important feature of this device. They permit the rubbers to seat themselves perfectly in the cylinder and the resulting friction is very uniform. In fact, the small periods of its variations are so short compared to that of the long bent levers that they are completely integrated by these levers, the record being almost a straight line. The controlling device consists of a hand screw to force down the rod operating the toggle joint. This pressure is transmitted through the ball-bearing since the rod is rotating with the shaft.

The manipulation of the machine is quite simple. A steam bath is allowed to flow through the chamber from the boilers throughout the experiment, maintaining all parts inside the shield at the temperature of the bath. The motor is started and the load is gradually increased by the control to the desired constant. When the water is evaporating freely and the thermal conditions have been maintained constant for some time, the weights are adjusted a little light and, as the water in the cup evaporates and the pointer comes to the zero, the clutch is operated throwing the counter and the recorder in gear, the weights and the counter having been observed and recorded. After any convenient period the weights are again adjusted a little light and the clutch again operated just as the pointer comes to zero, the counter and the weights being observed and recorded.

The calculation of the mass of the water evaporated is made in the usual way, but that of the mechanical energy may need a word of explanation. Since the ordinates and the abscissas of this curve are linear functions of the friction and the number of the revolutions of the rubbers, the following relations hold:

$$W = \int_0^s f. ds$$

$$= C \int_0^x y \cdot dx$$

$$= C \cdot A$$

but

$$A = X \bar{y}$$

$$= C_1 S \bar{y}$$

where  $\bar{y}$  = average ordinate

$$S = n \cdot 2\pi r$$

where  $n$  = no. of revolutions  
 $r$  = radius of disk

$$y = \frac{w_1}{w_2} l$$

where  $w_2$  = total weight of paper  
 $w_1$  = weight of A  
 $l$  = width of paper

$$c_1 = g \cdot G$$

where  $g$  = acc. due to gravity

$G$  = mass in grams to

displace marker 1<sup>cm</sup>.

∴

$$W = \frac{w_1}{w_2} l \cdot g \cdot G \cdot n \cdot 2\pi r.$$

The constant  $G$  is determined by empirical calibration, for which four steps are necessary: the calibration of the scale of one of the pendulums in grams per centimeter by suspending weights in a pan from the pulley: the adjustment of the mass of the other pendulum bob to the same grams per centimeter: the adjustment of either tape until any deflection of the disk gives the same displacement on both scales: the calibration of the marker in terms of these scales. This determines  $G$ .

A second set of observations is taken using a second cylinder of different conductivity capacity from that of the first and  $L$  is determined from the following relation:

$$W = u_1 + u_2 + R$$

where  $u_1$  = heat in ergs to the rubbers

$u_2$  = heat in ergs to water

$R$  = heat in ergs radiated

if the temperature of the shield approaches that of the cylinder

$$R \doteq 0 \quad \text{and}$$

$$W = u_1 + u_2$$

$$\text{but } u_2 = (m + m')L$$

where  $m$  = apparent loss of

water in the cup

$m'$  = water deposited

on cup due to

water vapor in

steam

and if  $m \doteq 0$

$$u_2 = mL$$

$$W = u_1 + mL.$$

Let

$$\begin{aligned} W &= u_1 + u_2 && \text{for the first cylinder} \\ W' &= u'_1 + u'_2 && \text{for the second cylinder} \\ &&& \text{and } u_2 = m L \\ &&& u'_2 = m' L \end{aligned}$$

$$\frac{u_1}{u'_1} = \frac{W - m L}{W' - m' L}$$

$$\text{But } du_1 = \frac{k_1 A_1}{l_1} (T_1 - T_2) dt$$

$$du_2 = \frac{k_2 A_2}{l_2} (T_1 - T_2) dt$$

$$du'_1 = \frac{k'_1 A'_1}{l'_1} (T'_1 - T'_2) dt$$

$$du'_2 = \frac{k'_2 A'_2}{l'_2} (T'_1 - T'_2) dt$$

where  $k$  = specific conductivity  
 $A$  = cross section of conductor  
 $l$  = length of conductor  
 $T$  = temperature  
 $t$  = time

integrating

$$u_1 = \frac{k_1 A_1}{l_1} \int_0^t (T_1 - T_2) dt$$

$$u_2 = \frac{k_2 A_2}{l_2} \int_0^t (T_1 - T_2) dt$$

$$u'_1 = \frac{k'_1 A'_1}{l'_1} \int_0^{t'} (T'_1 - T'_2) dt$$

$$u'_2 = \frac{k'_2 A'_2}{l'_2} \int_0^{t'} (T'_1 - T'_2) dt$$

and

$$\frac{u_1}{u'_1} = \frac{\int_0^t (T_1 - T_2) dt}{\int_0^{t'} (T'_1 - T'_2) dt}$$

$$\frac{u_2}{u'_2} = \frac{\frac{k_2 A_2}{l_2} \int_0^t (T_1 - T_2) dt}{\frac{k'_2 A'_2}{l'_2} \int_0^{t'} (T'_1 - T'_2) dt}$$

$$= R \cdot \frac{\int_0^t (T_1 - T_2) dt}{\int_0^t (T'_1 - T'_2) dt}$$

where  $R$  = ratio of the conductivity capacities of the two cylinders.

$$\begin{aligned} \frac{u_1}{u'_1} &= \frac{u_2}{u'_2 R} \\ &= \frac{m I}{m' R} \end{aligned}$$

$$\frac{m}{m' R} = \frac{W - mL}{W' - m' L}$$

$$L = \frac{W}{m} + \frac{1}{R - 1} \left( \frac{W}{m} - \frac{W'}{m'} \right)$$

In the second term of the right hand member the two factors always have opposite signs. The correction is therefore a negative quantity. By reducing the conductivity capacity of the rubbers and increasing that of the cylinder, this correction is reduced to a minimum. Only the ratio of the conductivity capacities is demanded by this formula, not the specific conductivities. This ratio is determined by the method of cooling.

The advantages of this method are: the measurement of all quantities involved to a high degree of accuracy, depending only on the skill of the mechanician: the elimination of all errors due to thermometry, the calorimeter constant, the water vapor in the steam, radiation and convection: the minimization and rigorous correction for conduction.

Preliminary tests of the most rigorous type show that all the factors that enter into this result are entirely within control. A long series of observations are to be made during the coming year, from which it is confidently expected that a value accurate to at least one part in a thousand will be obtained.

University of Pennsylvania.



ART. XI.—*The Phosphorescence of Zinc Sulphide through the Influence of Condensed Gases obtained by Heating Rare-Earth Minerals*; by CHARLES BASKERVILLE and L. B. LOCKHART.

HELIUM has been shown to be a product of the disintegration of radium emanations; it is also obtained from minerals which contain thorium and uranium. It has been shown by Afanassiew, Mme. Curie, Crookes, Strutt, Hoffman, Baskerville, and Boltwood that minerals containing these elements are radio-active.

It seemed to be of interest to ignite these minerals and condense the gases given off and note their effect upon phosphorescent zinc sulphide. The method of procedure was essentially that described in the preceding paper, except that the pulverized mineral was placed in the closed tube of hard glass instead of a radium preparation. Screens of Sidot's blende were prepared in strips for the purpose. The glowing of the screen was assumed to indicate the condensation of the emanation.

No final conclusion could be drawn from the experiments, which were distinctly qualitative. It appeared, however, that those minerals which offer the richest sources of helium gave the greatest amount of emanation. Most of the minerals were obtained by purchase, but we are indebted to Dr. Geo. F. Kunz for some of them, to Dr. H. S. Miner, of the Welsbach Lighting Co., for others, and to the Nernst Lamp Co., Pittsburg, Pa., for still others.

In addition to the minerals we made some experiments with uranium compounds\*, commercial thorium oxide, and the fractions of that element obtained in our laboratory.

The list of minerals, and observations follow:

Mineral.	Locality.	Result.
Aeschnite	Hitterö, Norway	Fair glow
Allanite (orthite)	Amherst Co., Virginia	No glow
Allanite	Amherst Co., Virginia	No glow
Annerödite	Norway	No glow
Auerlite	Henderson, N. C.	Fair glow
Bastnäsite	Manitou Springs, Col.	No glow
Brookite	Arkansas	No glow
Carnotite	La Salle Creek, Mont. Co., Colorado	Fine glow
Carnotite	Utah	No glow
Catapleiite	Brevig, Norway	No glow
Cerite	Bastnäs, Sweden	Fair glow
Cleveite	Moss, Norway	Fine glow
Columbite	Amelia Co., Virginia	No glow
Crytolite	Bluffton, Texas	Faint glow
with Fergusonite	(Llano)	

\* For which we are indebted to Dr. S. A. Tucker, Columbia University.

Mineral.	Locality.	Result.	
Crytolite	S. Co., Texas	No glow	
Euxenite	Spangereid, Norway	Fair glow	
Euxenite	Arendal, Norway	Good glow	
Fergusonite	Ytterby, Sweden	Fine glow	
Gadolinite	Fahlun, Sweden	No glow	
Gummite	Mitchell Co., N. C.	No glow	
Hjelmit	Karapfvet	No glow	
Monazite sand	Brazil, S. A.	Fair glow	
Monazite	Norway	Medium	
Monazite sand	Mitchell Co., N. C.	Very faint glow	
Mixite	Joachimsthal, Bohemia	No glow	
Orangite	Norway	Medium	
Orthite	Arendal, Norway	No glow	
Pitchblende (Uraninite)		Medium glow (below fair)	
Pechurane	Bohemia	Strong glow	
Samarskite	Mitchell Co., N. C.	Fine glow	
Steenstrupine	Urals	No glow	
Thorite	Langesund, Norway	Fair glow	
Thorite (Orangite)	Brevig, Norway	Fair glow	
Thorogummite	Bluffton, Llano Co., Tex.	No glow	
Tritomite	Brevig, Norway	No glow	
Tyrite	Tromsö, Norway	No glow	
Uraninite	North Carolina	Fine glow	
Uraninite	Joachimsthal, Bohemia	Very faint glow	
Uranite	(rare)	No glow	
Uranophane	Spruce Pine, Mitchell Co., N. C.	Fair glow	
Xenotime	Hitterö, Norway	Faint	
Ytthro-tantalite	Ytterby, Sweden	No glow	
Zeunerite	S. B., Germany	No glow	

Substance.	Prepared by	Result.	Remarks.
Uranium carbide	Tucker	No glow	Not expected from our knowl- edge of the activ- ity of uranium.
Uranium oxide	Tucker	No glow	
Uranium nitrate	Purchased	No glow	
Thorium-X	Miner. From 100 gals. wash-water	Fair glow	
Thorium oxide	Same as for Welsbach burners	Fair glow	Slight glow with tiffanyites. No glow with solid willemite.
Berzelium* oxide	Irwin. Monazite sand	No glow	No glow with tiffanyites.
Thorium* oxide	Davis. Monazite sand	Fair glow	Slight glow with tiffanyites.
Carolinium* oxide	Skinner. Monazite sand	No glow	

\* These preparations were made in our laboratory, University of North Carolina. All showed some but not the same radio-activity when tested by the electrical and photographic methods.

ART. XII.—*The Action of Radium Emanations on Minerals and Gems*;\* by CHARLES BASKERVILLE and L. B. LOCKHART.

KUNZ and Baskerville† have made some interesting observations concerning the action on minerals and gems of radium compounds of the highest activity enclosed within glass, as well as of mixtures of weaker preparations with a limited number of minerals, especially diamonds, willemite and kunzite.‡ Rutherford used willemite most satisfactorily§ for demonstrating to a large audience the condensation of the emanations by means of liquid air. It was thought advisable to subject other minerals, found by Kunz and Baskerville to be fluorescent or phosphorescent, or both fluorescent and phosphorescent under the influence of ultra-violet light, to similar treatment. We wish to express our obligations to Dr. Geo. F. Kunz, who generously provided us with most of the minerals, all of which were authenticated.

The method of testing was as follows: About 0.25 gram of radium chloride, 7000 uranies|| strong, was placed in a hard glass tube 2<sup>mm</sup> in diameter, sealed at one end. This was bound to a glass tube, provided with a stop-cock, which was bent so as to reach through one of the two holes in a rubber stopper to the bottom of a test-tube 2<sup>cm</sup> wide and 15<sup>cm</sup> deep. Through the other hole was passed a bent tube so that it just projected below the rubber. This tube was provided with a glass stop-cock and connected with an ordinary vacuum pump. The material upon which the action of the emanation was to be determined was placed in the wide test-tube. The tube was then dipped into liquid air contained in a suitable unsilvered Dewar bulb.

On opening the cock next to the pump while it was in operation a good vacuum was produced in the container tube. When this cock was closed, the radium chloride was heated to low redness. The cock between this and the test-tube was opened. The emanations were swept in and condensed. In every case the tube and contents were allowed to remain in the liquid air until they were assumed to have obtained an uniform temperature. All experiments were carried out in the dark and observations were made only after the eyes had become accustomed to the conditions.

\* Read before the Washington Section of the American Chemical Society, April 6th, 1904.

† Science.

‡ Patent applied for.

§ Address before the American Association for the Advancement of Science, St. Louis, Mo., Meeting, Dec., 1903.

|| By an "uranie" is meant the radio-activity of metallic uranium, which is taken as the standard.

It was learned that tiffanyite diamonds are quite as sensitive to the action of the emanations as the phosphorescent zinc sulphide. We did not have enough diamonds to change for each experiment, so in each trial a strip of Sidot's blende screen was inserted. This served to show that the emanations had been condensed. We were much surprised to learn on frequent repetition of the experiment that kunzite, which is so responsive to radium, neither fluoresced nor phosphoresced when the emanations were condensed thereon. It is, therefore, responsive to the beta- and gamma-rays only.

Before giving the results of the observations, which follow in tabulated form, it may be well to relate the results obtained in several experiments, the bearing of which upon the question in mind is apparent.

The cooling of zinc sulphide to the temperature of liquid air does not cause it to glow, with or without vacuum. A good vacuum and a sudden releasing of the same does not cause zinc sulphide to glow. But warming it to ordinary temperature after removal from liquid air does cause it to glow brilliantly. Chlorophane and kunzite cooled in liquid air show no phosphorescence.

Action of emanations from radium chloride (7000 activity) on :

Mineral.	Locality.	Result.	Remarks.	With Ultra-Violet Light.
Wollastonite	Harrisville, Lewis Co., N. Y.	Slow to phosphoresce, faint	Triboluminescent	Phosphorescent
White wollastonite (with idocrase and pink garnet)	Morelos, Mexico	Glowes brilliantly	Loses glow in less than five minutes	Phosphorescent
Wollastonite	Franklin Tunnel, N. J.	Glowes brilliantly	Loses glow quickly	Phosphorescent
Pectolite	Havers, N. Y.	Nothing		Phosphorescent
Pectolite	Paterson, N. J.	Nothing		Phosphorescent
Pectolite	Guttenburg, N. J.	Nothing		Phosphorescent
Spodumene	Paris, Me.	Nothing		Nothing
Spodumene (hid-denite)	Alexander Co., N. C.	Nothing		Nothing
Spodumene	U. G., Brazil, S. A.	Nothing		Nothing
Spodumene (kunzite)	Pala, Cal.	Very slight response		Phosphorescent
Willemite	Franklin, N. J.	Glowes well	Not so sensitive as zinc sulphide, or tiffanyite; glowes with emanations from commercial thorium oxide	Fluorescent and phosphorescent.
Greenockite		Glowes strongly	Goes away quickly	Fluorescent
Hyalite	Yellowstone Park	Nothing		Fluorescent
Colemanite	Mono Lake	Nothing		Phosphorescent
Chlorophane	Amherst, Va.	Nothing		Phosphorescent
Tiffanyite	5 Dutch diamonds, 2 $\frac{1}{4}$ k.	Glowes very easily and brilliantly	Lasts several hours	Phosphorescence prolonged

ART. XIII.—*The Behavior of Typical Hydrous Bromides when Heated in an Atmosphere of Hydrogen Bromide;*  
by J. LEHN KREIDER.

[Contributions from the Kent Chemical Laboratory of Yale Univ.—cxxxvii.]

IN former papers from this laboratory\* the results obtained in the dehydration of certain hydrous chlorides in air and in an atmosphere of hydrogen chloride have been studied and compared. In the present paper the effects of treating typical hydrous bromides in air and in an atmosphere of hydrogen bromide are described.

Hydrous barium bromide has been taken as a type of hydrous salts which when heated in air lose their water without much further decomposition; hydrous magnesium bromide as typical of salts which lose part of their water without much further decomposition and the remainder with simultaneous evolution of hydrogen bromide; and hydrous aluminum bromide as typical of salts which lose their water only with simultaneous loss of hydrogen bromide.

The method of experimentation was very similar to that followed by Gooch and McClenahan† in their experiments with hydrous chlorides.

For these experiments two combustion tubes 30<sup>cm</sup> in length and 2<sup>cm</sup> in diameter, set horizontally side by side in a tubulated paraffine bath, served as heating chambers. Each tube was fitted with a thermometer. Portions of the hydrous bromides to be treated were weighed into porcelain boats. One of these boats was inserted in each tube about midway in the bath (heated to a regulated temperature) and below the bulb of the thermometer, so that the temperature to which the material in the boat was submitted might be indicated by the thermometer as accurately as possible. Through one tube was drawn slowly a current of air purified by sulphuric acid, and through the other was sent a slow current of purified hydrogen bromide, generated in a flask by the action of bromine on a heated solution of naphthalene and kerosene, and passed through a purifying apparatus consisting of a tower containing successive layers of red phosphorus and glass wool and a wash bottle charged with a saturated solution of hydrobromic acid. At the end of a definite period, the boat was withdrawn, placed in a desiccator for a suitable interval to cool, and weighed. The residue in the boat was dissolved in water, and the bromine was precipitated by silver nitrate, the silver bromide being weighed on asbestos. In this way it was

\* Gooch and McClenahan, this Journal [4], xvii, 365. McClenahan, this Journal [4], xviii, 104.

† Loc. cit.

possible to determine the loss of water and hydrogen bromide from separate portions of the salt under examination, during definite intervals and at fixed temperatures, both in an atmosphere of hydrogen bromide and in air, and to find for each portion under examination what proportion of the total loss was hydrogen bromide and what was water. The tabular statements and the diagrams show the course of decomposition of the various salts for the temperatures indicated.

*Hydrous Barium Bromide.*

For the experiments with hydrous barium bromide, a well crystallized specimen was prepared by taking commercially pure barium carbonate, dissolving it in hydrochloric acid, precipitating by ammonium carbonate, washing the precipitate, dissolving in hydrobromic acid, and crystallizing and drying the crystals by pressing between filter papers. The analysis of different portions of this salt showed a definite composition, corresponding very closely to theory.

	Found.	Theory.
Ba .....	41.69%	41.60%
Br .....	48.05	47.95
2H <sub>2</sub> O .....	10.26	10.45
	100.00%	100.00%

The progress of the decomposition of this salt in air and in hydrogen bromide when submitted for a half hour to the temperatures indicated is shown in the accompanying table and diagram.

Here may be noted a gradual loss of water from 70° C. to 160° C., at which point the water is entirely expelled, without an appreciable loss of hydrogen bromide, either in air or hydrogen bromide, and that hydrogen bromide influences the process of dehydration in no marked way. There is nothing to show that any part of the water sustains a peculiar relation to the salt.

*Hydrous Magnesium Bromide.*

Similar experiments were performed with hydrous magnesium bromide, prepared by dissolving magnesium ribbon in hydrobromic acid and crystallizing the salt over sulphuric acid. The analysis of the salt gave a definite constitution corresponding fairly to theory.

	Found.	Theory.
Mg .....	08.68	08.27
Br .....	54.61	54.69
6H <sub>2</sub> O .....	36.71	37.04
	100.00	100.00

*Dehydration of Hydrous Barium Bromide.*

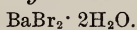

Atmosphere.	Weight taken.	Loss on heating.		Bromine in residue.			Water evolved.	Time.	Temperature.	
	gram.	gram.	per cent.	gram.	per cent.	Variation from theory.	per cent.	hrs.		
1 {	HBr	·2377	·0165	06·94	·1130	47·56	-0·39	06·55	$\frac{1}{2}$	70°C.
	Air	·2364	·0107	04·52	·1141	48·24	+0·29	04·81		
2 {	HBr	·2309	·0147	06·36	·1105	47·82	-0·13	06·23	$\frac{1}{2}$	80°C.
	Air	·2247	·0125	05·56	·1082	48·16	+0·21	05·77		
3 {	HBr	·2299	·0121	05·26	·1115	48·49	+0·54	05·80	$\frac{1}{2}$	90°C.
	Air	·2311	·0127	05·49	·1115	48·26	+0·31	05·80		
4 {	HBr	·2413	·0121	05·01	·1173	48·58	+0·63	05·64	$\frac{1}{2}$	100°C.
	Air	·2416	·0134	05·54	·1167	48·33	+0·38	05·92		
5 {	HBr	·2399	·0118	04·91	·1157	48·26	+0·31	05·22	$\frac{1}{2}$	110°C.
	Air	·2342	·0128	05·50	·1162	48·09	+0·14	05·64		
6 {	HBr	·2296	·0115	05·00	·1111	48·41	+0·46	05·46	$\frac{1}{2}$	120°C.
	Air	·2287	·0127	05·50	·1095	47·91	-0·04	05·46		
7 {	HBr	·2501	·0157	06·27	·1208	48·32	+0·37	06·64	$\frac{1}{2}$	130°C.
	Air	·2472	·0135	05·46	·1195	48·37	+0·42	05·88		
8 {	HBr	·2389	·0198	06·58	·1147	48·03	+0·08	06·66	$\frac{1}{2}$	140°C.
	Air	·2304	·0148	06·42	·1113	48·31	+0·36	06·78		
9 {	HBr	·2491	·0258	10·36	·1190	47·78	+0·17	10·19	$\frac{1}{2}$	150°C.
	Air	·2438	·0251	10·29	·1167	47·86	-0·09	10·20		
10 {	HBr	·2460	·0269	10·93	·1190	48·37	+0·42	11·35	$\frac{1}{2}$	160°C.
	Air	·2416	·0242	10·01	·1166	48·26	+0·31	10·32		

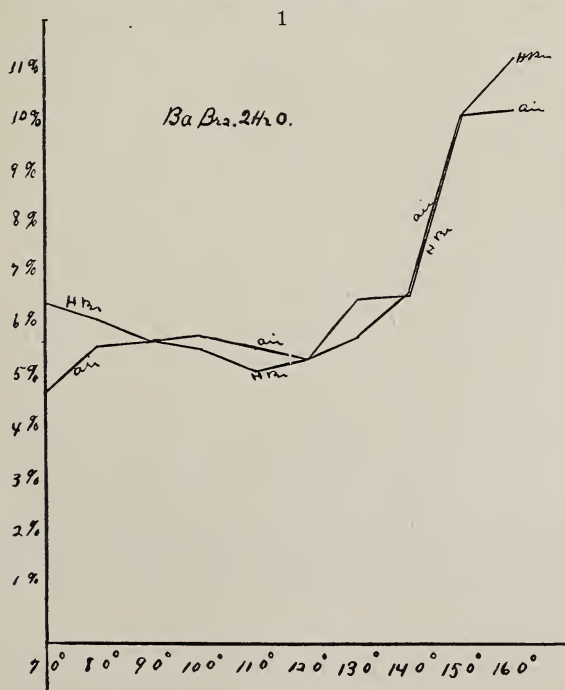

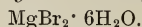
*Dehydration of Hydrous Magnesium Bromide.*

Atmosphere.	Weight taken.	Loss on heating.		Bromine in residue.		HBr lost.	Water lost.	Time. hrs.	Temperature.	
	gram.	gram.	per cent.	gram.	per cent.	per cent.	per cent.			
1	HBr	·2389	·0000	00·00	·1310	54·81	00·12	00·12	$\frac{1}{2}$	70° C.
	Air	·2400	·0000	00·00	·1319	54·98	00·29	00·29		
2	HBr	·1370	·0000	00·00	·0751	54·85	00·16	00·16	$\frac{1}{2}$	80°
	Air	·1380	·0012	00·86	·0752	54·55	00·14	00·72		
3	HBr	·1259	·0019	01·50	·0693	54·96	00·27	01·77	$\frac{1}{2}$	90°
	Air	·1482	·0023	01·95	·0813	54·87	00·18	02·13		
4	HBr	·1220	·0053	04·34	·0664	54·46	00·23	04·11	$\frac{1}{2}$	100°
	Air	·1448	·0048	03·31	·0797	55·07	00·38	03·69		
5	HBr	·1345	·0070	05·20	·0736	54·76	00·07	05·27	$\frac{1}{2}$	110°
	Air	·1384	·0103	07·44	·0752	54·33	00·36	07·80		
6	HBr	·1374	·0115	08·36	·0751	54·69	00·00	08·36	$\frac{1}{2}$	120°
	Air	·1353	·0120	08·86	·0737	54·50	00·19	08·67		
7	HBr	·1331	·0114	08·56	·0724	54·41	00·28	08·28	$\frac{1}{2}$	130°
	Air	·1317	·0128	09·71	·0714	54·28	00·41	09·30		
8	HBr	·1345	·0140	10·40	·0734	54·58	00·11	10·29	$\frac{1}{2}$	140°
	Air	·1369	·0183	13·37	·0733	53·59	01·11	12·26		
9	HBr	·1375	·0216	15·71	·0748	54·47	00·22	15·49	$\frac{1}{2}$	150°
	Air	·1358	·0251	18·48	·0727	53·58	01·12	17·36		
10	HBr	·1313	·0140	10·66	·0714	54·46	00·23	10·46	$\frac{1}{2}$	160°
	Air	·1311	·0324	24·71	·0698	53·26	01·44	23·27		
11	HBr	·1366	·0170	12·44	·0744	54·39	00·31	12·13	$\frac{1}{2}$	170°
	Air	·1379	·0159	11·53	·0744	54·00	00·69	10·84		
12	HBr	·1399	·0220	15·72	·0760	54·35	00·34	15·38	$\frac{1}{2}$	180°
	Air	·1358	·0232	17·08	·0723	53·27	01·43	15·65		
13	HBr	·1285	·0217	16·89	·0696	54·75	00·06	16·95	$\frac{1}{2}$	190°
	Air	·1324	·0275	20·77	·0702	53·06	01·65	19·12		
14	HBr	·1345	·0284	21·11	·0731	54·42	00·27	20·84	$\frac{1}{2}$	200°
	Air	·1382	·0312	22·57	·0730	52·87	01·84	20·73		
15	HBr	·1349	·0282	20·90	·0731	54·19	00·50	20·40	$\frac{1}{2}$	210°
	Air	·1350	·0331	24·51	·0704	52·20	02·51	22·00		
16	HBr	·1337	·0297	22·21	·0722	54·01	00·68	21·53	$\frac{1}{2}$	220°
	Air	·1320	·0379	28·71	·0686	52·03	02·69	26·02		
17	HBr	·1354	·0340	25·11	·0731	54·02	00·67	24·47	$\frac{1}{2}$	230°
	Air	·1373	·0606	44·13	·0649	47·43	07·35	36·78		
18	HBr	·1376	·0401	29·14	·0740	53·69	01·01	28·13	$\frac{1}{2}$	240°
	Air	·1360	·0555	40·80	·0665	48·93	05·80	35·00		

From these results it appears that approximately a third of the water may be removed from the hydrous magnesium bromide, submitted at once to the temperatures indicated, either in air or in an atmosphere of hydrogen bromide, without considerable simultaneous loss of hydrogen bromide from the salt, the trifling loss being somewhat less in the atmosphere of



hydrogen bromide than in air, Thereafter the loss of hydrogen bromide when the salt is heated in air increases generally with the temperature and is inhibited, as is the loss of water,

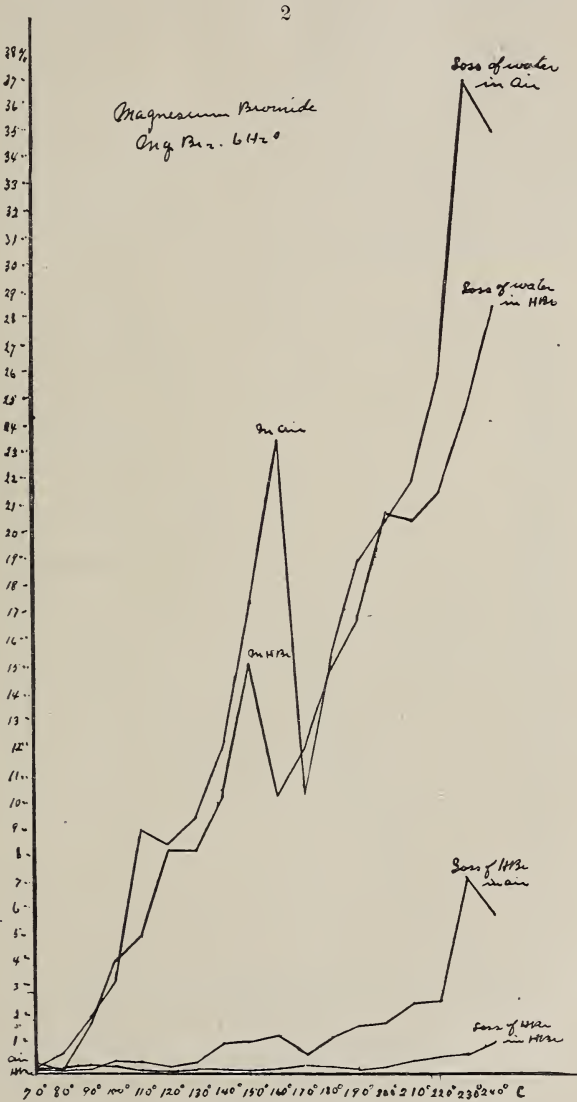

by the atmosphere of hydrogen bromide. It appears that about a third of the water of magnesium bromide bears a relation to the salt different from that of the remainder.

When submitted at once, without preliminary heating, to a temperature of  $170^{\circ}$  in air and  $160^{\circ}$  in hydrogen bromide, the hydrous salt melts and in the melted condition loses water less rapidly than the solid salt at a somewhat lower temperature. This is what makes the break in the curves which indicate the losses of water and hydrogen bromide. When the salt was heated successively, for intervals of a half hour, at temperatures varying by ten degrees, the progress of dehydration was more uniform, as is shown in the accompanying diagram, all the water being lost at  $160^{\circ}$  in air and  $220^{\circ}$  in hydrogen bromide, the inhibiting action of hydrogen bromide upon the dehydration being more marked as the temperature rises from the point at which the first third is lost.

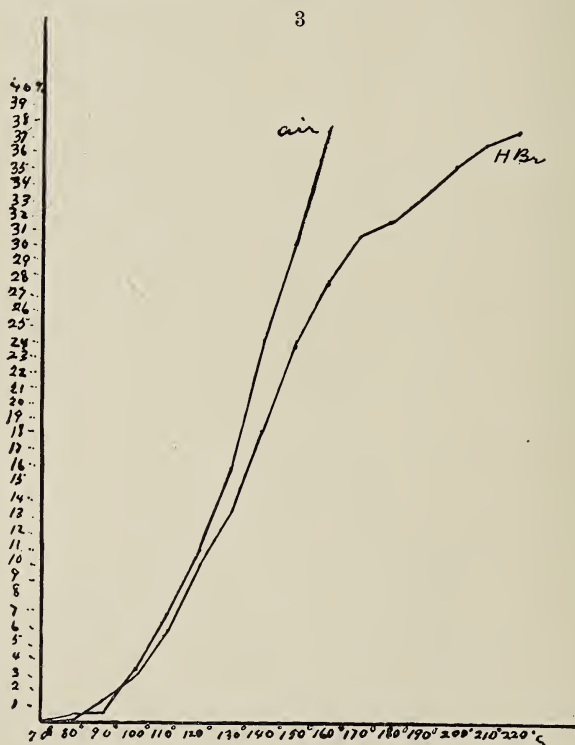

*Hydrous Aluminum Bromide.*

The hydrous aluminum bromide used was prepared by dissolving pure aluminum chloride in water, precipitated aluminum hydroxide by ammonium hydroxide, filtering off the aluminum hydroxide, and washing until free from impurities. This precipitate was then dissolved in hydrobromic acid, and

the solution thus formed allowed to crystallize by evaporation in vacuum over sulphuric acid: the crystals thus formed were of nearly normal constitution.

	Found.	Theory.
Al -----	07·25%	07·20%
Br <sub>3</sub> -----	63·90	63·95
6H <sub>2</sub> O -----	28·85	28·85
	100·00	100·00

The course of dehydration of hydrous aluminum bromide in air and in an atmosphere of hydrogen bromide is shown in the accompanying table and diagram.

*Dehydration of Aluminum Bromide.*

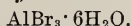

Atmosphere.	Weight taken.	Loss on heating.		Bromine in residue.		HBr lost.	Water lost.	Time. hrs.	Temperature.																																																																																																																																																																																																																																											
	gram.	gram.	per cent.	gram.	per cent.	per cent.	per cent.																																																																																																																																																																																																																																													
1	HBr	·1308	·0000	00·00	----	----	----	½	70° C.																																																																																																																																																																																																																																											
	Air	·1306	·0000	00·00	----	----	----			2	HBr	·1394	·0000	00·00	----	----	----	½	80°	Air	·1381	·0000	00·00	----	----	----	3	HBr	·1344	·0000	00·00	----	----	----	½	90°	Air	·1360	·0000	00·00	----	----	----	4	HBr	·1317	·0008	00·60	·0831	63·13	00·83	½	100°	Air	·1316	·0014	01·06	·0842	64·05	00·10	5	HBr	·1364	·0008	00·58	·0861	63·60	00·35	½	110°	Air	·1378	·0024	01·74	·0865	62·83	01·13	6	HBr	·1381	·0008	00·57	·0878	63·62	00·33	½	120°	Air	·1367	·0054	03·95	·0834	61·07	02·91	7	HBr	·1297	·0006	00·46	·0825	63·64	00·31	½	130°	Air	·1318	·0106	08·04	·0767	58·24	05·78	8	HBr	·1379	·0011	00·79	·0831	60·32	03·67	½	140°	Air	·1357	·0127	09·35	·0771	56·85	07·18	9	HBr	·1366	·0113	08·27	·0730	53·46	10·62	½	150°	Air	·1355	·0549	40·51	·0485	35·84	28·46	10	HBr	·1308	·0121	09·25	·0740	56·57	07·43	½	160°	Air	·1348	·0668	49·55	·0413	30·66	33·71	11	HBr	·1380	·0270	19·56	·0703	50·94	13·17	½	170°	Air	·1390	·0919	66·11	·0281	20·72	43·77	12	HBr	·1378	·0561	40·71	·0477	34·65	29·67	½	180°	Air	·1346	·0949	70·50	·0232	17·28	47·26	13	HBr	·1331	·0850	63·86	·0280	21·09	43·40	½	190°	Air	·1307	·0976	74·67	·0193	14·80	49·72	14	HBr	·1362	·0938	68·87	·0232	17·08	47·46	½	200°	Air	·1377	·1090	79·15	·0197	14·33	50·24	15	HBr	·1355	·0958	70·70	·0246	18·04	46·49	½	210°	Air	·1345	·1040	77·32
2	HBr	·1394	·0000	00·00	----	----	----	½	80°																																																																																																																																																																																																																																											
	Air	·1381	·0000	00·00	----	----	----			3	HBr	·1344	·0000	00·00	----	----	----	½	90°	Air	·1360	·0000	00·00	----	----	----	4	HBr	·1317	·0008	00·60	·0831	63·13	00·83	½	100°	Air	·1316	·0014	01·06	·0842	64·05	00·10	5	HBr	·1364	·0008	00·58	·0861	63·60	00·35	½	110°	Air	·1378	·0024	01·74	·0865	62·83	01·13	6	HBr	·1381	·0008	00·57	·0878	63·62	00·33	½	120°	Air	·1367	·0054	03·95	·0834	61·07	02·91	7	HBr	·1297	·0006	00·46	·0825	63·64	00·31	½	130°	Air	·1318	·0106	08·04	·0767	58·24	05·78	8	HBr	·1379	·0011	00·79	·0831	60·32	03·67	½	140°	Air	·1357	·0127	09·35	·0771	56·85	07·18	9	HBr	·1366	·0113	08·27	·0730	53·46	10·62	½	150°	Air	·1355	·0549	40·51	·0485	35·84	28·46	10	HBr	·1308	·0121	09·25	·0740	56·57	07·43	½	160°	Air	·1348	·0668	49·55	·0413	30·66	33·71	11	HBr	·1380	·0270	19·56	·0703	50·94	13·17	½	170°	Air	·1390	·0919	66·11	·0281	20·72	43·77	12	HBr	·1378	·0561	40·71	·0477	34·65	29·67	½	180°	Air	·1346	·0949	70·50	·0232	17·28	47·26	13	HBr	·1331	·0850	63·86	·0280	21·09	43·40	½	190°	Air	·1307	·0976	74·67	·0193	14·80	49·72	14	HBr	·1362	·0938	68·87	·0232	17·08	47·46	½	200°	Air	·1377	·1090	79·15	·0197	14·33	50·24	15	HBr	·1355	·0958	70·70	·0246	18·04	46·49	½	210°	Air	·1345	·1040	77·32	·0158	11·76	52·85														
3	HBr	·1344	·0000	00·00	----	----	----	½	90°																																																																																																																																																																																																																																											
	Air	·1360	·0000	00·00	----	----	----			4	HBr	·1317	·0008	00·60	·0831	63·13	00·83	½	100°	Air	·1316	·0014	01·06	·0842	64·05	00·10	5	HBr	·1364	·0008	00·58	·0861	63·60	00·35	½	110°	Air	·1378	·0024	01·74	·0865	62·83	01·13	6	HBr	·1381	·0008	00·57	·0878	63·62	00·33	½	120°	Air	·1367	·0054	03·95	·0834	61·07	02·91	7	HBr	·1297	·0006	00·46	·0825	63·64	00·31	½	130°	Air	·1318	·0106	08·04	·0767	58·24	05·78	8	HBr	·1379	·0011	00·79	·0831	60·32	03·67	½	140°	Air	·1357	·0127	09·35	·0771	56·85	07·18	9	HBr	·1366	·0113	08·27	·0730	53·46	10·62	½	150°	Air	·1355	·0549	40·51	·0485	35·84	28·46	10	HBr	·1308	·0121	09·25	·0740	56·57	07·43	½	160°	Air	·1348	·0668	49·55	·0413	30·66	33·71	11	HBr	·1380	·0270	19·56	·0703	50·94	13·17	½	170°	Air	·1390	·0919	66·11	·0281	20·72	43·77	12	HBr	·1378	·0561	40·71	·0477	34·65	29·67	½	180°	Air	·1346	·0949	70·50	·0232	17·28	47·26	13	HBr	·1331	·0850	63·86	·0280	21·09	43·40	½	190°	Air	·1307	·0976	74·67	·0193	14·80	49·72	14	HBr	·1362	·0938	68·87	·0232	17·08	47·46	½	200°	Air	·1377	·1090	79·15	·0197	14·33	50·24	15	HBr	·1355	·0958	70·70	·0246	18·04	46·49	½	210°	Air	·1345	·1040	77·32	·0158	11·76	52·85																															
4	HBr	·1317	·0008	00·60	·0831	63·13	00·83	½	100°																																																																																																																																																																																																																																											
	Air	·1316	·0014	01·06	·0842	64·05	00·10			5	HBr	·1364	·0008	00·58	·0861	63·60	00·35	½	110°	Air	·1378	·0024	01·74	·0865	62·83	01·13	6	HBr	·1381	·0008	00·57	·0878	63·62	00·33	½	120°	Air	·1367	·0054	03·95	·0834	61·07	02·91	7	HBr	·1297	·0006	00·46	·0825	63·64	00·31	½	130°	Air	·1318	·0106	08·04	·0767	58·24	05·78	8	HBr	·1379	·0011	00·79	·0831	60·32	03·67	½	140°	Air	·1357	·0127	09·35	·0771	56·85	07·18	9	HBr	·1366	·0113	08·27	·0730	53·46	10·62	½	150°	Air	·1355	·0549	40·51	·0485	35·84	28·46	10	HBr	·1308	·0121	09·25	·0740	56·57	07·43	½	160°	Air	·1348	·0668	49·55	·0413	30·66	33·71	11	HBr	·1380	·0270	19·56	·0703	50·94	13·17	½	170°	Air	·1390	·0919	66·11	·0281	20·72	43·77	12	HBr	·1378	·0561	40·71	·0477	34·65	29·67	½	180°	Air	·1346	·0949	70·50	·0232	17·28	47·26	13	HBr	·1331	·0850	63·86	·0280	21·09	43·40	½	190°	Air	·1307	·0976	74·67	·0193	14·80	49·72	14	HBr	·1362	·0938	68·87	·0232	17·08	47·46	½	200°	Air	·1377	·1090	79·15	·0197	14·33	50·24	15	HBr	·1355	·0958	70·70	·0246	18·04	46·49	½	210°	Air	·1345	·1040	77·32	·0158	11·76	52·85																																																
5	HBr	·1364	·0008	00·58	·0861	63·60	00·35	½	110°																																																																																																																																																																																																																																											
	Air	·1378	·0024	01·74	·0865	62·83	01·13			6	HBr	·1381	·0008	00·57	·0878	63·62	00·33	½	120°	Air	·1367	·0054	03·95	·0834	61·07	02·91	7	HBr	·1297	·0006	00·46	·0825	63·64	00·31	½	130°	Air	·1318	·0106	08·04	·0767	58·24	05·78	8	HBr	·1379	·0011	00·79	·0831	60·32	03·67	½	140°	Air	·1357	·0127	09·35	·0771	56·85	07·18	9	HBr	·1366	·0113	08·27	·0730	53·46	10·62	½	150°	Air	·1355	·0549	40·51	·0485	35·84	28·46	10	HBr	·1308	·0121	09·25	·0740	56·57	07·43	½	160°	Air	·1348	·0668	49·55	·0413	30·66	33·71	11	HBr	·1380	·0270	19·56	·0703	50·94	13·17	½	170°	Air	·1390	·0919	66·11	·0281	20·72	43·77	12	HBr	·1378	·0561	40·71	·0477	34·65	29·67	½	180°	Air	·1346	·0949	70·50	·0232	17·28	47·26	13	HBr	·1331	·0850	63·86	·0280	21·09	43·40	½	190°	Air	·1307	·0976	74·67	·0193	14·80	49·72	14	HBr	·1362	·0938	68·87	·0232	17·08	47·46	½	200°	Air	·1377	·1090	79·15	·0197	14·33	50·24	15	HBr	·1355	·0958	70·70	·0246	18·04	46·49	½	210°	Air	·1345	·1040	77·32	·0158	11·76	52·85																																																																	
6	HBr	·1381	·0008	00·57	·0878	63·62	00·33	½	120°																																																																																																																																																																																																																																											
	Air	·1367	·0054	03·95	·0834	61·07	02·91			7	HBr	·1297	·0006	00·46	·0825	63·64	00·31	½	130°	Air	·1318	·0106	08·04	·0767	58·24	05·78	8	HBr	·1379	·0011	00·79	·0831	60·32	03·67	½	140°	Air	·1357	·0127	09·35	·0771	56·85	07·18	9	HBr	·1366	·0113	08·27	·0730	53·46	10·62	½	150°	Air	·1355	·0549	40·51	·0485	35·84	28·46	10	HBr	·1308	·0121	09·25	·0740	56·57	07·43	½	160°	Air	·1348	·0668	49·55	·0413	30·66	33·71	11	HBr	·1380	·0270	19·56	·0703	50·94	13·17	½	170°	Air	·1390	·0919	66·11	·0281	20·72	43·77	12	HBr	·1378	·0561	40·71	·0477	34·65	29·67	½	180°	Air	·1346	·0949	70·50	·0232	17·28	47·26	13	HBr	·1331	·0850	63·86	·0280	21·09	43·40	½	190°	Air	·1307	·0976	74·67	·0193	14·80	49·72	14	HBr	·1362	·0938	68·87	·0232	17·08	47·46	½	200°	Air	·1377	·1090	79·15	·0197	14·33	50·24	15	HBr	·1355	·0958	70·70	·0246	18·04	46·49	½	210°	Air	·1345	·1040	77·32	·0158	11·76	52·85																																																																																		
7	HBr	·1297	·0006	00·46	·0825	63·64	00·31	½	130°																																																																																																																																																																																																																																											
	Air	·1318	·0106	08·04	·0767	58·24	05·78			8	HBr	·1379	·0011	00·79	·0831	60·32	03·67	½	140°	Air	·1357	·0127	09·35	·0771	56·85	07·18	9	HBr	·1366	·0113	08·27	·0730	53·46	10·62	½	150°	Air	·1355	·0549	40·51	·0485	35·84	28·46	10	HBr	·1308	·0121	09·25	·0740	56·57	07·43	½	160°	Air	·1348	·0668	49·55	·0413	30·66	33·71	11	HBr	·1380	·0270	19·56	·0703	50·94	13·17	½	170°	Air	·1390	·0919	66·11	·0281	20·72	43·77	12	HBr	·1378	·0561	40·71	·0477	34·65	29·67	½	180°	Air	·1346	·0949	70·50	·0232	17·28	47·26	13	HBr	·1331	·0850	63·86	·0280	21·09	43·40	½	190°	Air	·1307	·0976	74·67	·0193	14·80	49·72	14	HBr	·1362	·0938	68·87	·0232	17·08	47·46	½	200°	Air	·1377	·1090	79·15	·0197	14·33	50·24	15	HBr	·1355	·0958	70·70	·0246	18·04	46·49	½	210°	Air	·1345	·1040	77·32	·0158	11·76	52·85																																																																																																			
8	HBr	·1379	·0011	00·79	·0831	60·32	03·67	½	140°																																																																																																																																																																																																																																											
	Air	·1357	·0127	09·35	·0771	56·85	07·18			9	HBr	·1366	·0113	08·27	·0730	53·46	10·62	½	150°	Air	·1355	·0549	40·51	·0485	35·84	28·46	10	HBr	·1308	·0121	09·25	·0740	56·57	07·43	½	160°	Air	·1348	·0668	49·55	·0413	30·66	33·71	11	HBr	·1380	·0270	19·56	·0703	50·94	13·17	½	170°	Air	·1390	·0919	66·11	·0281	20·72	43·77	12	HBr	·1378	·0561	40·71	·0477	34·65	29·67	½	180°	Air	·1346	·0949	70·50	·0232	17·28	47·26	13	HBr	·1331	·0850	63·86	·0280	21·09	43·40	½	190°	Air	·1307	·0976	74·67	·0193	14·80	49·72	14	HBr	·1362	·0938	68·87	·0232	17·08	47·46	½	200°	Air	·1377	·1090	79·15	·0197	14·33	50·24	15	HBr	·1355	·0958	70·70	·0246	18·04	46·49	½	210°	Air	·1345	·1040	77·32	·0158	11·76	52·85																																																																																																																				
9	HBr	·1366	·0113	08·27	·0730	53·46	10·62	½	150°																																																																																																																																																																																																																																											
	Air	·1355	·0549	40·51	·0485	35·84	28·46			10	HBr	·1308	·0121	09·25	·0740	56·57	07·43	½	160°	Air	·1348	·0668	49·55	·0413	30·66	33·71	11	HBr	·1380	·0270	19·56	·0703	50·94	13·17	½	170°	Air	·1390	·0919	66·11	·0281	20·72	43·77	12	HBr	·1378	·0561	40·71	·0477	34·65	29·67	½	180°	Air	·1346	·0949	70·50	·0232	17·28	47·26	13	HBr	·1331	·0850	63·86	·0280	21·09	43·40	½	190°	Air	·1307	·0976	74·67	·0193	14·80	49·72	14	HBr	·1362	·0938	68·87	·0232	17·08	47·46	½	200°	Air	·1377	·1090	79·15	·0197	14·33	50·24	15	HBr	·1355	·0958	70·70	·0246	18·04	46·49	½	210°	Air	·1345	·1040	77·32	·0158	11·76	52·85																																																																																																																																					
10	HBr	·1308	·0121	09·25	·0740	56·57	07·43	½	160°																																																																																																																																																																																																																																											
	Air	·1348	·0668	49·55	·0413	30·66	33·71			11	HBr	·1380	·0270	19·56	·0703	50·94	13·17	½	170°	Air	·1390	·0919	66·11	·0281	20·72	43·77	12	HBr	·1378	·0561	40·71	·0477	34·65	29·67	½	180°	Air	·1346	·0949	70·50	·0232	17·28	47·26	13	HBr	·1331	·0850	63·86	·0280	21·09	43·40	½	190°	Air	·1307	·0976	74·67	·0193	14·80	49·72	14	HBr	·1362	·0938	68·87	·0232	17·08	47·46	½	200°	Air	·1377	·1090	79·15	·0197	14·33	50·24	15	HBr	·1355	·0958	70·70	·0246	18·04	46·49	½	210°	Air	·1345	·1040	77·32	·0158	11·76	52·85																																																																																																																																																						
11	HBr	·1380	·0270	19·56	·0703	50·94	13·17	½	170°																																																																																																																																																																																																																																											
	Air	·1390	·0919	66·11	·0281	20·72	43·77			12	HBr	·1378	·0561	40·71	·0477	34·65	29·67	½	180°	Air	·1346	·0949	70·50	·0232	17·28	47·26	13	HBr	·1331	·0850	63·86	·0280	21·09	43·40	½	190°	Air	·1307	·0976	74·67	·0193	14·80	49·72	14	HBr	·1362	·0938	68·87	·0232	17·08	47·46	½	200°	Air	·1377	·1090	79·15	·0197	14·33	50·24	15	HBr	·1355	·0958	70·70	·0246	18·04	46·49	½	210°	Air	·1345	·1040	77·32	·0158	11·76	52·85																																																																																																																																																																							
12	HBr	·1378	·0561	40·71	·0477	34·65	29·67	½	180°																																																																																																																																																																																																																																											
	Air	·1346	·0949	70·50	·0232	17·28	47·26			13	HBr	·1331	·0850	63·86	·0280	21·09	43·40	½	190°	Air	·1307	·0976	74·67	·0193	14·80	49·72	14	HBr	·1362	·0938	68·87	·0232	17·08	47·46	½	200°	Air	·1377	·1090	79·15	·0197	14·33	50·24	15	HBr	·1355	·0958	70·70	·0246	18·04	46·49	½	210°	Air	·1345	·1040	77·32	·0158	11·76	52·85																																																																																																																																																																																								
13	HBr	·1331	·0850	63·86	·0280	21·09	43·40	½	190°																																																																																																																																																																																																																																											
	Air	·1307	·0976	74·67	·0193	14·80	49·72			14	HBr	·1362	·0938	68·87	·0232	17·08	47·46	½	200°	Air	·1377	·1090	79·15	·0197	14·33	50·24	15	HBr	·1355	·0958	70·70	·0246	18·04	46·49	½	210°	Air	·1345	·1040	77·32	·0158	11·76	52·85																																																																																																																																																																																																									
14	HBr	·1362	·0938	68·87	·0232	17·08	47·46	½	200°																																																																																																																																																																																																																																											
	Air	·1377	·1090	79·15	·0197	14·33	50·24			15	HBr	·1355	·0958	70·70	·0246	18·04	46·49	½	210°	Air	·1345	·1040	77·32	·0158	11·76	52·85																																																																																																																																																																																																																										
15	HBr	·1355	·0958	70·70	·0246	18·04	46·49	½	210°																																																																																																																																																																																																																																											
	Air	·1345	·1040	77·32	·0158	11·76	52·85																																																																																																																																																																																																																																													

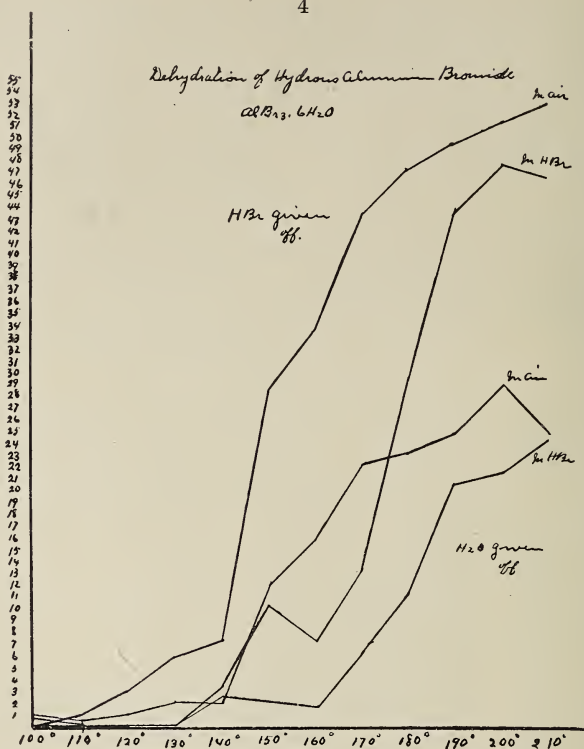

From these results it appears that, at 100° and higher temperatures, hydrous aluminum bromide loses water and hydrogen bromide simultaneously, both in air and in an atmosphere of hydrogen bromide; but that the loss of water, as well as of hydrogen bromide, from the salt is retarded by the atmosphere of hydrogen bromide. At the highest temperature recorded, 210° C. the salt still retained bromine. There is nothing to indicate that any part of the water possesses a different relation to the salt from that possessed by any other part of the water.

#### *Discussion of Results.*

In correlating the phenomena noted, Cushman's hypothesis of inner and outer linkages of water relative to the molecular complex, upon the assumption of quadrivalent oxygen, seems applicable.

Thus the symbol

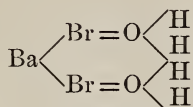

for hydrous barium bromide, showing two molecules of water externally attached, suggests the observed easy removal of all water without simultaneous loss of hydrogen bromide, and indicates, as was observed, that concentration of hydrogen bromide in the system is not likely to affect the course of dehydration.

The symbol

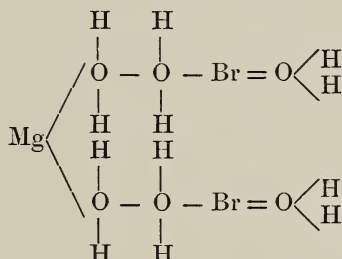

for hydrous magnesium bromide, in which two molecules of water are externally attached and four internally, shows why one-third of the water may be removed at a moderate temperature, without much loss of hydrogen bromide; why the remaining two-thirds of the water require a higher temperature for their removal with simultaneous evolution of hydrogen bromide; and why increase in the concentration of hydrogen bromide in the system retards both the loss of water and hydrogen bromide, after the first third of the water has been expelled.

The symbol

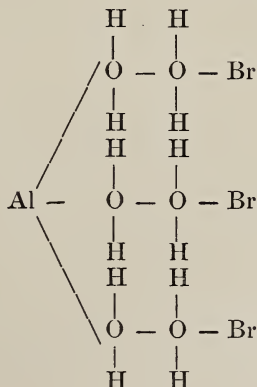

for hydrated aluminum bromide suggests the observed impossibility of evolving water without simultaneous loss of hydrogen bromide, the salt tending on continued heating to go over to the oxide. With a salt showing this constitution the natural effect of the concentration of hydrogen bromide in the system would be to retard the dehydration of the salt, as was observed.

So it appears that the phenomena of dehydration of the hydrated bromides under discussion admit of explanation upon Cushman's hypothesis of the molecular attachment of water within and without the complex.

The author is greatly indebted to Prof. F. A. Gooch for advice and assistance throughout this work.

ART. XIV.—*The Glacial (Dwyka) Conglomerate of South Africa*; by EDWARD T. MELLOR.

[Communicated by permission of the Director of the Geological Survey of the Transvaal.]

*Introductory.*—Few rocks have aroused so widespread and so sustained an interest as the Glacial Conglomerate occurring at the base of the Karroo System of South Africa, generally known as the Dwyka Conglomerate. From the time when attention was first directed to it by Bain in 1856, down to the present, the Dwyka Conglomerate has continued to be a source of almost continual discussion.

In the first instance, this interest was in a great measure due to the very different views held by various geologists as to the nature of the conglomerate, and especially to the opposition offered by many to the theory of its glacial origin—a question which one may venture to regard as finally settled by the accumulation of evidence in recent years. This establishment of the glacial character of the deposits included under the term Dwyka Conglomerate, which occur over thousands of square miles in South Africa, and which correspond closely with similar formations of corresponding age in India, Australia, and South America, lends a newer and perhaps more widely spread interest to the study of this series, and of the conditions under which it was formed. To the South African geologist the rock derives additional interest from the fact that it affords the only geological horizon common to the various colonies yet established with any degree of certainty.

*Nomenclature.*—The term “Glacial Conglomerate” was used by E. J. Dunn on his map published in 1873\* for the northern outcrops of the conglomerate, while he still retained for the more southerly occurrences an old name, “Trap Conglomerate,” used by Wyley. In the second edition of his map,† two years later, while retaining the term Glacial Conglomerate for the northern outcrops, Dunn applied the term “Dwyka Conglomerate” to those of the southern parts of Cape Colony and Natal. The term Dwyka is derived from a river of that name in Cape Colony in the neighborhood of which the conglomerate is typically developed. The name is now frequently applied to the glacial conglomerate at the base of the Karroo System generally throughout South Africa. It might perhaps be more appropriately restricted to the southern type, which, as will be pointed out, differs in some important respects from the more northerly occurrences, especially as the intermediate

\* E. J. Dunn, Geological Sketch Map of Cape Colony, London, 1873.

† E. J. Dunn, Geological Sketch Map of South Africa, London, 1875.

phases have not yet been fully worked out. For the northern conglomerates the original term "Glacial Conglomerate" is as appropriate as ever, and I have preferred it in various descriptions of these conglomerates in the Transvaal.

*Distribution of the Conglomerates.*—The main area occupied by the Karroo System covers a large part of South Africa, including the major portions of Cape Colony and Natal, nearly the whole of the Orange River Colony and most of the south-eastern Transvaal. This area would be included roughly between lines drawn from a point on the south-east coast of Cape Colony, near to the mouth of the Gualana River, W. to near the head of the Doorn River beyond Matjesfontein, NNE. to the Lange Berg on the southern border of Namaqualand, NW. by Prieska and Kimberley to Middelburg and Belfast in the Transvaal, SSE. by Amsterdam to Vryheid, and SSW. to the coast of Cape Colony at the mouth of St. Johns River. This area includes most of the higher portions of South Africa, and almost the whole of it lies above a level of 3000 feet. In the Drakensberg the uppermost portions of the Karroo System attain an elevation of over 8000 feet.

The series of glacial deposits at the base of the system crop out almost continuously around the margin of the vast area occupied by it, following approximately the lines given above. Along their southern margin the Karroo rocks, particularly the Dwyka Conglomerate, have been affected by the intense folding characteristic of the southern portions of Cape Colony. There the lowest Karroo Beds are frequently highly inclined, and their outcrop is correspondingly reduced in width, but over the whole of the remainder of the area occupied by them the Karroo rocks are practically horizontal, and the outcrops of the various divisions occupy broad tracts of country. This is especially the case with the Glacial Conglomerate and lower portions of the system, which in many places form extensive outliers around the margin of the main area as above defined.

*Relationships and Age.*—In its southern portions in Cape Colony the Dwyka Conglomerate grades downwards into a series of greenish shales (Lower Dwyka Shales) some 700 feet in thickness, which in turn lie conformably upon the quartzites of the Witteberg Series. These, together with the Bokkeveld Beds and the Table Mountain Series, constitute the "Cape System" of Cape Colony.

Passing northwards, the Dwyka Series overlaps the lower divisions of the Cape System, which thin out in that direction, and comes to lie unconformably upon various much older systems of rocks. In all the more northerly localities where the conglomerate has been studied, it lies unconformably on the older South African rocks, the surfaces of which are fre-



quently glaciated. In Cape Colony and Natal the Dwyka Conglomerate passes upwards into the Eccla Shales, a series of shales and mudstones identical in character with the shales occurring with the Dwyka Conglomerate, and in composition corresponding with the finer portions of the matrix of that rock. The Eccla shales are succeeded by a very extensive series of sandstones and shales, attaining a maximum thickness of some thousands of feet, and including on at least two different horizons seams of coal. These, together with the Eccla Shales and Dwyka Conglomerate, constitute the Karroo System of South Africa. Intrusive sheets of diabase occur throughout the Karroo rocks, and the uppermost portion of the system consists, for the most part, of a succession of lava-flows usually amygdaloidal and of basaltic composition interbedded with sandstones containing much fragmental material of volcanic origin.

The Bokkeveld Beds of Cape Colony have yielded a numerous assemblage of fossils related to the Devonian fauna of Europe; the Witteberg beds which succeed them and underlie the Dwyka Series have so far afforded only a few imperfect specimens showing general Carboniferous affinities. With the Eccla Shales in Cape Colony and with the beds associated with the Coal Seams of the Transvaal, which sometimes, as at Vereeniging, lie immediately above the Glacial Conglomerate, a fossil flora is associated of Permo-Carboniferous age\* having a number of genera in common with the lower part of the Indian Gondwana System, and the Coal Measures of New South Wales.

Compared with the southern and eastern margins of the Karroo area, the northern outcrops of the Glacial Conglomerate and associated beds show a considerable diminution in thickness, a feature shown also by the other divisions of the Karroo System. In the southern outcrops in Cape Colony the Dwyka Conglomerate has a thickness of about 1000 feet; on the north of the Colony, in the neighbourhood of Prieska, it is stated not to exceed 500 feet.† In Natal and the eastern Transvaal the thickness of the conglomerate is about 300 feet,‡ while on the northern border of the formation, in the central portions of the Transvaal, it rarely reaches 100 feet, and may be locally absent altogether. As will be seen from the descriptions given below, this difference in thickness corresponds with differences in composition, and in general characters dependent upon variations in the original conditions of deposition in the different localities.

\* A. C. Seward, *Notes on the Plant Remains from Vereeniging*, Q. J. G. S., vol. liv, pp. 92-93. London, 1898.

† A. W. Rogers, *The Geology of Cape Colony*, London, 1905.

‡ G. A. F. Molengraaff, *Geology of the Transvaal*, Edinburgh, 1904, p. 73.

*Description of the Dwyka Conglomerate in the Southern Outcrops.*—The earlier studies and descriptions of the Dwyka conglomerate were confined to its occurrence in the southern portions of Cape Colony and in Natal. In the southern examples especially the conglomerate has certain characteristics which led to much controversy as to its origin. Its appearance in the Dwyka locality was thus described by Mr. E. J. Dunn: \* “The conglomerate consists of a bluish grey base so fine that its constituents are not resolvable, except under high magnifying power, and then no crystals are disclosed; it appears to be a very fine indurated mud; in this base are enclosed boulders, pebbles, angular fragments, and grains of a great variety of rocks, such as granite, granulite, gneiss, mica, and other schists, quartz rock, hard sandstone, jasper, hornfels, quartz, small pieces of felspar, etc.”

The included fragments, which range in size from mere grains to boulders several feet in diameter, are distributed in the matrix without definite arrangement. The rock as a whole is very hard and fractures pass indifferently through matrix and boulders alike. By weathering it frequently produces a yellowish clay, through which the hard rock fragments and boulders of the original conglomerate are scattered. Besides the conglomerate beds, other shaly beds occur devoid of included fragments. Individual beds persist over long distances, maintaining at the same time their distinctive lithological characters. The conglomerate beds vary from a few inches to hundreds of feet in thickness. In the southern parts of Cape Colony the conglomerate often shows a schistose structure resulting from the earth movements which have affected that area—to the effects of which is probably also due in part the extreme hardness of the southern rock as compared with its northern representative.

*Various theories concerning the Origin of the Dwyka Conglomerate.*—The dark green color of the conglomerate, its richness in minerals not usually abundant in rocks of sedimentary origin, including much chloritic material, its extreme hardness, its crystalline appearance and the frequent absence of bedding through great thicknesses of rock, disposed almost every observer, including many geologists of wide experience, to attribute to the conglomerate an igneous origin. Expressive of these views are the following names applied to the rock at various times by different workers: “Claystone-porphry,” “Trap-conglomerate,” “Melaphyre-breccia,” “Volcanic-breccia,” “Trap-breccia.” Many and various were the theories advanced at different times and by different observers to

\* E. J. Dunn, Report on the Camdeboo and Nieuwveldt Coal, p. 7, Cape Town, 1879.

account for the peculiar characters of the conglomerate. A. G. Bain, "The Father of South African Geology," who first described the Dwyka Conglomerate in 1856, suggested that it represented a flow from an immense volcano. Prof. A. H. Green thought it to be a "coarse shingle formed along a receding coast-line," while from Green's specimens Sir A. Geikie and Dr. F. H. Hatch considered it had the aspect of a volcanic breccia. The majority of South African geologists favored the igneous theory, accounting for its peculiar characters and occasional stratification by referring its origin to submarine volcanoes.

A glacial origin was first attributed to the conglomerate in 1868 in a paper on the Geology of Natal by Dr. P. C. Sutherland,\* who had previously regarded the rock as a lava-flow. Sutherland, who was familiar with the conglomerate in Natal, where the rock has more the features of a terrestrial glacial deposit, and rests in places upon striated rock surfaces, clearly stated the real character of the rock. The glacial view received early support from Stow,† who, however, referred the glaciation to a much later period, and subsequently from Schenck.‡ Dunn, who did so much to work out the main features of the distribution of the Glacial Conglomerate as shown in the various editions of his "Geological Sketch Map of South Africa," regarded the rock as largely due to the action of floating ice, an agent which no doubt had much to do with the southern deposits.

It is only quite recently, however, that owing to the accumulation of evidences§ from various localities in South Africa the glacial origin of the Dwyka Conglomerate has received anything approaching general acceptance.

*Recent Studies of the Glacial Conglomerate.*—In 1898 Dr. Molengraaff|| published a description of the Dwyka Conglomerate, and overlying Ecca beds, as developed in the Vryheid district of the Transvaal, to the north of the Natal border (now included in the latter colony). In the Vryheid district the Dwyka Conglomerate averages about 300 feet in thickness, and lies unconformably upon an old land surface composed mainly of the hard quartzites and shales of the Barberton formation—the surfaces of which are frequently polished and striated. Both the conglomerate and succeeding Ecca Shales offer good

\* P. C. Sutherland, *On the Geology of Natal, Pietermaritzburg*, 1868.

† G. W. Stow, *On some Points in S. A. Geology*, Q. J. G. S., vol. xxvii, pp. 497-548. London, 1871.

‡ A. Schenck, *Die Geologische Entwicklung Südafrikas*, Pet. Mitt., Band xxxiv. Gotha, 1888.

§ See recent reports of the Geological Surveys of Cape Colony, Natal and the Transvaal.

|| G. A. F. Molengraaff, *The Glacial Origin of the Dwyka Conglomerate*, Trans. Geol. Soc. S. A., vol. iv, 1898.

opportunities for study in the many sections exposed in the deeply cut valleys of the eastern rivers. In this district the Dwyka Conglomerate includes both unstratified and stratified portions, in each of which faceted and striated bowlders are abundant, together with many angular and sub-angular rock fragments. The stratified beds are sometimes almost devoid of bowlders and pebbles, and include mudstone and shales, the latter indistinguishable from the overlying Ecce Shales into which the Dwyka Conglomerate gradually passes.

In 1899 Messrs. Rogers and Schwartz\* studied the Glacial Conglomerate in the Prieska district in the north of Cape Colony. They found the Conglomerate here to present all the features of a true ground moraine, with abundance of faceted and striated bowlders; and lying unconformably upon all the older rocks of the district, fragments of which occur in the conglomerate and which afford fine examples of "roches mon-tonnées" and striated surfaces. The direction of the striæ and distribution of the bowlders point to a movement from the north southwards.

In his report for the same year Dr. Corstorphine† summed up the results obtained in the north and south of Cape Colony and elsewhere, and compared the features of the northern and southern deposits, contrasting the northern Glacial Conglomerates, possessing the characters of a ground moraine, with the southern Dwyka, which is to be looked upon as "a sediment formed under a probably inland water, into which there floated the icebergs calved from the front of the glacier or glaciers on the northern shore."

The identity in character of the Glacial Conglomerate with a true ground moraine, seen in the northern parts of Cape Colony, comes out with even greater clearness along the northern edge of the main area occupied by the Karroo System in the Transvaal.

*The Glacial Conglomerate in the Transvaal.*—In the central portions of the Transvaal, and particularly in a district lying along the eastern railway line from Pretoria to Middelburg, I have recently mapped many outliers of Karroo rocks isolated by the progress of denudation from the main body, which covers extensive areas to the south and south-east. These outliers sometimes include portions of the sandstones, grits, and shales associated with coal-seams which form the upper portion of the Karroo System as developed in this part

\* Rogers and Schwartz, Ann. Rep. of the Geol. Commission, 1899. Cape Town, 1900. On the Orange River Ground Moraine. Trans. Phil. Soc. S. A., vol. xi, part 2, 1900.

† G. S. Corstorphine, Ann. Rep. of the Geol. Commission, 1899. Cape Town, 1900. (Full references to the previous literature will be found in this paper.)

of the Transvaal. They are, however, frequently reduced to patches consisting almost entirely of the Glacial Conglomerate and associated beds. The copious sandy drift shed by these outliers frequently renders their examination difficult, but in some cases they offer more than usually good opportunities for the study of the Glacial Conglomerate and its relationships to the underlying rocks. In the district here more especially referred to, the glacial deposits consist for the most part of a conglomerate showing all the characters to be expected in one formed beneath an extensive ice-sheet. This conglomerate is

1



very irregular in distribution, and varies greatly in thickness within short distances, partly in consequence of its original deposition on an irregular land surface, and partly as a result of subsequent denudation. Its average thickness is about fifty feet. In depth the rock is sometimes greenish in color, but at the surface it is usually light yellow, and crops out in characteristic humpy masses (see fig. 1). The matrix is a sandy-looking material consisting of sharply angular fragments of quartz and of various rocks—quartzites, hard shales, felsites, granophyres—common in the district. These angular fragments vary in size from the smallest particles to pieces several inches in diameter. Irregularly distributed through the matrix, and with a conspicuous absence of any sort of arrangement as to size or orientation, occur abundant pebbles and

bowlders of very miscellaneous composition, and ranging in size up to a diameter of eight or ten feet. These pebbles and bowlders are frequently faceted, and those of very hard materials are always highly polished, while bowlders of somewhat softer nature, especially if fine in grain, such as hard shales and weathered felsitic rocks, frequently show striations. A network of cracks in some cases divides the pebbles into a number of fragments which have been again cemented into a whole. In any particular locality there is always a preponderance of bowlders derived from rocks which locally underlie the Glacial Conglomerate, associated with others easily recognizable as derived from more distant sources, which are always to the north of the present position of the bowlders. Thus along the eastern railway line, to the south of an area mainly occupied by the Waterberg Formation and the Red Granite, the Glacial Conglomerate contains an abundance of bowlders derived from these rocks. South of the outcrop of the hard white Magaliesberg quartzites, fragments of the white quartzites are very abundant. Those lying nearest to the ridge from which they were derived are angular and frequently of huge dimensions, so that when weathered out and lying on the surface they are conspicuous objects at a distance of two or three miles. On the eastern Witwatersrand the conglomerate contains many bowlders derived from the Rand Series together with others formed of the hard cherts of the Dolomite to the north. Except quite locally, the lower and more massive portions of the conglomerate rarely show any traces of bedding, but are occasionally traversed by irregular partings dividing the rock into rude sheets with undulating billowy surfaces. Towards the upper portions of the conglomerate, lenticular beds of fine-grained massive sandstone frequently occur, together with patches of white and cream-colored shales and mudstones. The shales appear to have been formed in local pockets below the ice. They consist of the finest glacial mud. The examination of a district of some hundreds of square miles in extent leads to the conclusion that at the termination of the period during which glacial conditions obtained, the country was left covered with an almost complete mantle of glacial deposits, quite similar in character and distribution to those remaining in other parts of the world from extensive glaciation of more recent date. After the cessation of glacial conditions the conglomerates and associated deposits appear to have suffered a certain amount of sub-aërial erosion and denudation, during which materials derived from the glacial deposits underwent re-arrangement and re-deposition, giving rise in some cases to beds of conglomerate very similar in composition and general appearance to those of glacial origin, with

which they are liable to be confused, but differing in the more orderly arrangement of their materials, including a definite orientation of the pebbles and bowlders. These secondary conglomerates occasionally occur at the base of the purely sedimentary series which succeed the true glacial deposits, and by which as a result of a period of long continued subsidence the latter were ultimately entirely covered. This sedimentary series included the succession of beds constituting in the Transvaal area the upper portion of the Karroo System. Later formations were also possibly represented but of these no ves-

2



tige has hitherto been discovered in the Transvaal. Raised subsequently to an average elevation of 5000 feet above the sea, the Karroo System has been again subjected to denuding forces and the removal of the overlying sandstones, shales, and grits of the Coal Measures has laid bare extensive areas of the underlying Glacial Conglomerate.

Although modified by the double process of denudation to which it has been subjected, it still presents in its distribution a striking similarity to that of more recently formed glacial deposits. Following the contours of the land surfaces upon which it was originally laid down, it ranges within distances of a few miles through variations in elevation of three to five hundred feet. It is frequently well developed on one slope of a hill and entirely absent from the other. When protected

from erosion it fills preëxisting valleys, and is usually especially abundant below ancient escarpments of the older rocks, and in such places boulders often of very large size, attaining in some cases eight or ten feet in diameter, are exceptionally numerous. After the complete weathering away of the matrix the boulders remain abundantly scattered over areas previously occupied by the conglomerate. (See fig. 2.)

*Glaciated Surfaces below the Conglomerate—Direction of Ice-Movement.*—The progressive removal by denudation of the Glacial Conglomerate around the margins of the areas now occupied by the Karroo System and its outliers continually lays bare fresh portions of the underlying old land surface. Where these include outcrops of hard and moderately fine-grained rocks, the latter frequently present excellent examples of glacially striated surfaces,\* some of which are represented in the photographs reproduced in figures 3, 4, 5. Striated surfaces of this kind were long ago described by Sutherland in Natal, by Griesbach in the same colony, by Dunn and Schenk in the neighbourhood of the Vaal River, and more recently by Molen-graaff in the South-Eastern Transvaal, and by Rogers and Schwartz in the Prieska district in the north of Cape Colony. While working on an area lying about 25 miles east of Pretoria in 1903, I found the surface shown in figure 3, and later those in figures 4 and 5. These latter occur on the edge of an outlier of Karroo rocks some 25 miles further east, which includes the coal seam worked at the Douglas colliery. I have since met with many similar surfaces distributed over an area of some 300 square miles. The striation in most cases is exceedingly clear, and the direction of ice-movement easily determined and remarkably consistent. In all the examples found it only varies within a few degrees from magnetic north and south, the direction of movement being in a southerly direction, which is also true in general for the other districts in South Africa where striated surfaces have been found. This consistency of direction over so considerable an area and in the case of surfaces lying 25 miles apart, points to the existence of an ice-sheet of considerable magnitude, rather than to that of a number of more or less isolated glaciers, a conclusion which is supported by the nature of the land surface laid bare by the disappearance of the Karroo deposits.

Where the Waterberg Sandstone Formation, which occupies much of the district here referred to, has been long exposed to ordinary denudation, the rivers cut deep valleys and gorges in the sandstone, giving rise to very varied and occasionally rug-

\* E. T. Mellor, On Some Glaciated Land Surfaces occurring in the District between Pretoria and Balmoral. Trans. Geol. Soc. S. A., vol. vii, part 1, 1904.



3



4



ged scenery. Where, however, the overlying Glacial Conglomerate is only now in process of removal, the country retains the rounded outlines characteristic of a glaciated landscape.

*Northern extension of the Glacial Conglomerate.*

I have recently met with good examples of the Glacial Conglomerate much further to the north than any hitherto described.\* (Figures 1 and 2.) These are situated near the junc-

5



tion of the Elands and Olifants Rivers, about 90 miles north of the latitude of Johannesburg, and are interesting for the additional light they throw upon the northward extent of the country subjected to glacial action in early Karroo times.

EXPLANATION OF FIGURES.

FIGURE 1.—Glacial conglomerate near the junction of the Elands and Olifants Rivers, Transvaal (75 miles NE. of Pretoria).

FIGURE 2.—Weathered-out Glacial conglomerate, same locality. The figure stands upon grits of the upper Karroo formation.

FIGURE 3.—Glaciated surface. Elands River Valley (25 miles E. of Pretoria).

FIGURES 4 and 5.—Glaciated surfaces north of Balmoral (50 miles E. of Pretoria).

The striated rocks are red quartzitic sandstones of the Waterberg Series.

Geological Survey, Pretoria, Transvaal.

\* E. T. Mellor, *Outliers of the Karroo System near the Junction of the Elands and Olifants Rivers in the Transvaal*, *Trans. Geol. Soc. S. A.*, vol. vii, part 3, 1904.

ART. XV.—*The Formation of Natural Bridges;* by  
HERDMAN F. CLELAND.

UNTIL recently the text-books of Geology and Physical Geography have given the idea, whether intentionally or not, that natural bridges are universally formed by the partial caving in of a long cavern, the bridge being that portion of the roof strong enough to span the cavity.\* The belief seems to be prevalent that these cavities extended for long distances, a condition comparable to that which would exist if the greater part of the roof of Mammoth Cave should fall in, leaving a small portion as a bridge. This theory is simple and logical and is one which immediately appeals to the reader, but, as will be seen from the examples cited in this paper, not only is it not of universal application but it must be exceptional rather than otherwise. The writer was led to this study by an examination of the natural bridge near North Adams, Mass. which has long been considered to be a typical example and proof of the formation from caverns.

The North Adams Natural Bridge spans Hudson Brook and has been an object of more than local interest for many years both because of its natural beauty and because of the rarity of these objects. Hudson Brook is a small stream emptying into Beaver Creek, a tributary of the Hoosick River. From the dam (shown in the sketch fig. 1) to the pre-glacial valley the brook flows through a gorge 30 to 60 feet deep and from 5 to 40 feet wide, the average width above the bridge being from 1 to 10 feet and below from 10 to 30 feet. This gorge is cut in a coarsely crystalline marble which, because of its color and texture, presents a striking appearance. The rock is Cambro-Silurian and belongs to the Stockbridge formation.

The top of the natural bridge is 44 feet above the water of the stream and the bridge itself is about 8 feet thick. The span of the bridge is less than 10 feet long and the width at present 25 feet, but at one time it probably extended a short distance farther south where it is now fallen in. It is extremely difficult to take a good photograph of the bridge because, as will be seen from the sketch, the stream turns sharply both above and below. Because of this condition it was found necessary to make a drawing, in order to give a correct idea of its appearance.

Prof. E. Hitchcock described the North Adams Natural Bridge and published a rough drawing of it in 1841.† Concerning this drawing he says, "I thought it better that a sketch

\* Chamberlain and Salisbury, *Geol.*, vol. i, pp. 145-147.

† *Geology of Mass.*, by Edward Hitchcock, vol. i, 1841, pp. 287-288.

should be taken by one not at all accustomed to drawing, than that no memento be left of this interesting place," (there was danger at that time that the bridge might be destroyed by the quarry-men.) Hovey\* in his "Celebrated American Caverns" describes this bridge but gives the locality as Adams, Mass.

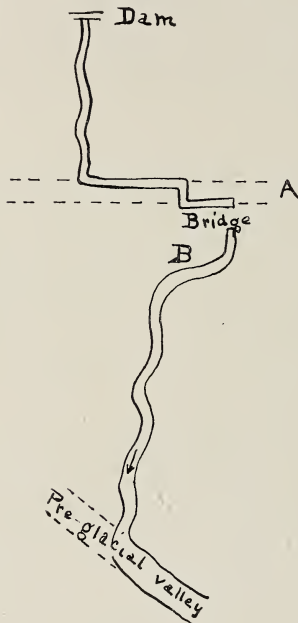

FIG. 1.—Sketch map of Hudson Brook, Mass., showing the position of the natural bridge, the joint planes A-A, and the pre-glacial valley.

In the accompanying sketch (fig. 1) the relation of the stream to the joint planes is indicated by the dotted lines A-A. The channel through which the stream flowed previous to the formation of the bridge is also well marked a few feet to the west at B. A pot-hole situated near the edge of the gorge at B is further evidence of the former position of the brook.

The bridge was probably formed as follows: When the stream flowed into the gorge through the ancient channel, it plunged over a fall into the pre-glacial valley. Some of the water in the joint plane nearest the present bridge seeped through an approximately horizontal crack a short distance under the present arch of the bridge. The solvent power of

The explanation of the formation of the North Adams Natural Bridge, as given by Hitchcock and accepted by Hovey, is that it is the section of the roof of a cavern, the ends of which have fallen in. In illustration of this point, Hovey states that, "the combination of cave, chasm and natural bridge, on Hudson Brook, Mass. is even a better example (than that of the Natural Bridge in Virginia) of the same thing," i. e., "that what are now open canons were once caves, the arch being merely a remnant of an ancient cave roof."

On examining the course of the stream and the rock in the vicinity of the North Adams Natural Bridge one is struck with the width of the joints, and the fact that the stream has, for a portion of its course, followed the joint planes.

\* "Celebrated American Caverns," H. C. Hovey, pp. 14 and 206.

the water containing carbon dioxide ( $\text{CO}_2$ ) gradually increased the size of the crack until it was still further enlarged by the erosion of the stream. The stream was finally entirely diverted from its former channel at B to its present course. The gorge from the dam to the pre-glacial valley is a succession of broken pot-holes varying in size up to 6 or 8 feet in diameter, showing

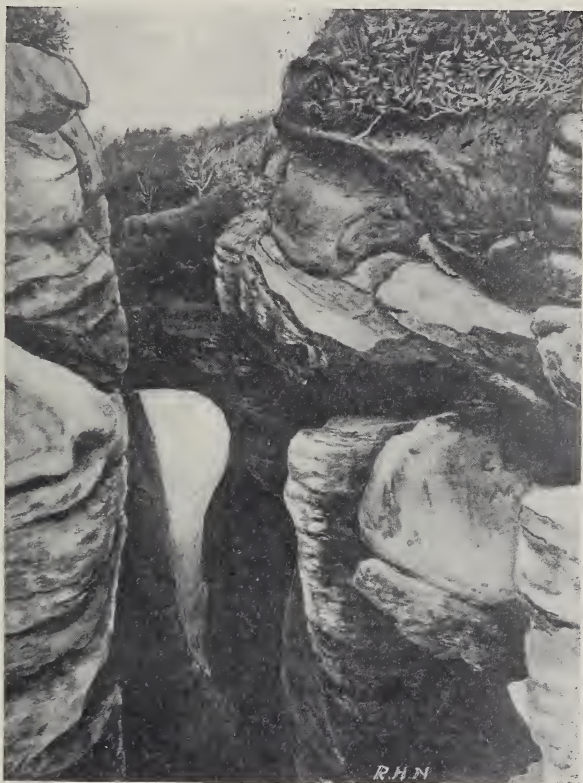

FIG. 2.—The North Adams Natural Bridge as seen from the south.<sup>1893</sup> Formerly the bridge probably extended nearly to the foreground of the picture.

that after the tunnel was made the gorge was largely excavated in this way. The pre-glacial valley in which the Hudson Brook flows below the gorge is broad but to some extent choked with glacial drift.

The origin of the famous Natural Bridge of Lexington, Va.,\* as explained by Walcott, was similar to that of the Natural Bridge of North Adams, Mass., but is on a larger scale. Before

\* National Geographic Magazine 1893, vol. v, p. 59.

the formation of the bridge the stream, which now flows under, then flowed upon the surface of what is now the arch and probably plunged over a fall a short distance below the present site of the bridge. While the stream was flowing over this fall a portion of the water was percolating through a joint plane or other crack up stream and discharging into the stream under the fall, enlarging its passage by its solvent power. In the course of time this passage became sufficiently large to contain all of the water of the stream, and the bridge resulted. It is not possible to say what the length of this underground passage was. It must have been somewhat longer than at present, but "whether one hundred feet or several hundred feet" it is not possible to determine.

The description of some wonderful natural bridges in Utah,\* in a recent paper, suggests an explanation similar to that given above, except that, in the case of these bridges, the rock is said to be a sandstone (pink or gray) instead of a limestone. The most probable explanation is that, at one time, the river flowed over a fall a short distance below the lowest bridge and that, as the stream was cutting back, a portion of the water was pouring through a fissure up the stream and reappearing at the brink of the fall, dissolving out the cement of the sandstone along its course. This underground passage was gradually enlarged by the washing out of the unconsolidated sand, resulting in a tunnel of sufficient size to hold the entire volume of the stream. After this event the valley was eroded to nearly its level. This process was repeated three times with the formation of three bridges. When it is remembered that one of these bridges spans a canyon 335' wide, that the lower side of the arch is 357' above the stream and that the material of which they are constructed is sandstone, it will be seen that any explanation requiring a tunnel of great size extending for a long distance is untenable. It is, however, unsafe to do more than speculate upon the formation of these bridges, since so little is known of the rock of which they are composed.

In the Yellowstone National Park occurs a small natural bridge of rhyolite. The bridge consists of two vertical slabs of lithoidal rhyolite, parts of the contorted layers of lava flow, which stand nearly vertical in this place.† They are slightly curved and are separated by open crevices with roughened scoriaceous walls. Of the two slabs forming the ledge the eastern is two feet thick at its ends and thinner in the middle. There is a space of two feet between it and the western slab, which is four feet thick. "The span of the arch is about 30 feet and it rises about 10 feet, the top of the bridge being some

\* W. W. Dyar, *Cent. Mag.*, vol. lxviii, 1904, pp. 505-511.

† *Geol. of Yellowstone Nat. Park*, U. S. G. S. Mon., vol. 32, pt. II, pp. 386-7.

40 feet above the stream." The explanation of the formation of the bridge is as follows: The stream which flows underneath



FIG. 3.—Vertical plates of rhyolite. Yellowstone Natural Bridge. (Mon. U. S. G. S. 32, pt. II, plate 49.)

the bridge has been able to excavate, owing to a former waterfall and the peculiar platy structure of the rhyolite, in which curved layers of extremely different physical texture and friability offered a favorable site for attack by frost and water.

The formation of lava bridges is usually explained as follows: The surface of a lava flow cools and hardens while the interior is still in a molten condition. As a result of this condition, if the molten rock beneath continues to flow, a tunnel will result. Such tunnels are of common occurrence on Mt. Vesuvius, the volcanoes of the western states and in other volcanic regions. From such a tunnel a bridge might be formed by the caving in of the greater part of the roof. A study of the photograph (fig. 3) showing the structure of the lava of which the Yellowstone Natural Bridge is formed shows that such an explanation is untenable in this case at least, the rock being composed of approximately vertical plates of lava of different degrees of compactness. The writer has not made a study of other lava bridges, but it seems probable that the mode of formation of the Yellowstone bridge may be exceptional for bridges of this character.

In each of the cases cited the top of the bridge was formerly a portion of the bed of the stream. If natural bridges were formed as commonly supposed, it would be unusual to find that a surface stream had once been superimposed upon the cavern for its entire length. There is, for example, seldom any relation between the surface topography of a country and the underground passages of extensive caves.

Occasionally a small natural bridge occurs near the opening of a cavern or where a spring flows from beneath a cliff. Such a bridge is the sandstone arch spanning a spring which emerges from beneath the sandstone capping of Lookout Mountain near Chattanooga, Tenn. The bridge is formed by the widening of a transverse joint, first by weathering alone and later by the combined action of weathering and erosion, thus separating the bridge from the cliff. The breadth of the span was increased largely by weathering.

The conclusion to which one is led by this study of natural bridges from different parts of the United States and composed of various kinds of rocks—marble, limestone, sandstone, and lava—is that, although bridges may be formed, and undoubtedly have occasionally been formed, by the partial falling in of the roof of a long underground tunnel, the usual mode of formation is that described above. It should, however, be said that examples exist concerning which it is difficult to say which mode of formation was the more prominent.



ART. XVI.—*Quartz from San Diego County, California* ;\*  
by G. A. WARING, Stanford University, California.

IN quartz crystals occurring in the pockets of the gem-bearing pegmatite veins of the Pala and Rincon districts, San Diego County, California, several peculiarities of crystallization have been observed, which it is believed have not before been described. These crystals occur attached to the sides of the cavities, associated usually with albite and orthoclase. The most remarkable feature about them is the common development of tetartohedral faces.

On two crystals, figs. 3 and 7, the facial angles were measured by means of a Fuess reflecting goniometer, and the following rare faces determined, according to Bravais-Miller system of notation.

On the small crystal, fig. 7:—

	Measured.	Given by Dana.
$m \wedge \Gamma$ (40 $\bar{1}$ 1)	11° 12'	11° 8'
$m \wedge x$ (51 $\bar{6}$ 1)	11° 50'	12° 1'

On the crystal, fig. 3:—

	Measured.	Given by Dana.
$m \wedge x$ (51 $\bar{6}$ 1)	11° 27'	12° 1'
$m \wedge y$ (41 $\bar{5}$ 1)	{ 14° 8' 14° 54'	14° 35'
$m \wedge s$ (11 $\bar{2}$ 1)	{ 14° 10' 37° 39'	37° 58'

The  $\Gamma$  (40 $\bar{1}$ 1) and  $M$  (30 $\bar{3}$ 1) faces also are present on this crystal, determined by measurement with the contact goniometer, and the  $u$ -face (31 $\bar{1}$ 1) is also developed; it is distinctly visible with the pocket-lens, but too small to be measured with certainty. It has the terminal pyramids partly developed at the other end also, and imperfectly showing the rare faces. It is intergrown with a left-handed crystal which on the face preserved exhibits the faces  $s$  (2 $\bar{1}$ 11),  $x$  (6 $\bar{1}$ 51) and  $\Gamma$  (40 $\bar{1}$ 1).

Twinning is common and, so far as observed, is always according to the Dauphiné law. The upper part of the crystal shown in fig. 3 is such a twin, of two right-handed individuals very perfectly joined, the twinning plane but faintly shown by cloudy patches within the crystal.

Fig. 1 is a twin of two left-handed individuals, the plane of twinning being well marked on the surface by a discontinuity in the prismatic striations, and by a plane of dark patches

\* Sincere appreciation is expressed to Dr. M. Murgoci of Vienna for assistance in the measurement of the inter-facial angles, and to Dr. J. P. Smith of Stanford University for advice and aid in the preparation of this article.

within. This twinning is also markedly shown at the junction of the prism and pyramid faces, by the development on one individual of the  $e(50\bar{5}1)$  face and on the other of the  $\Gamma(40\bar{1}1)$  face. This twin has developed on one member between the  $m$  and  $z$  faces the  $x(6\bar{1}\bar{5}1)$ ,  $\Gamma(40\bar{1}1)$  and  $e(50\bar{5}1)$  faces, and between  $m$  and  $r$  on the adjacent edge to the right, the  $x(6\bar{1}\bar{5}1)$

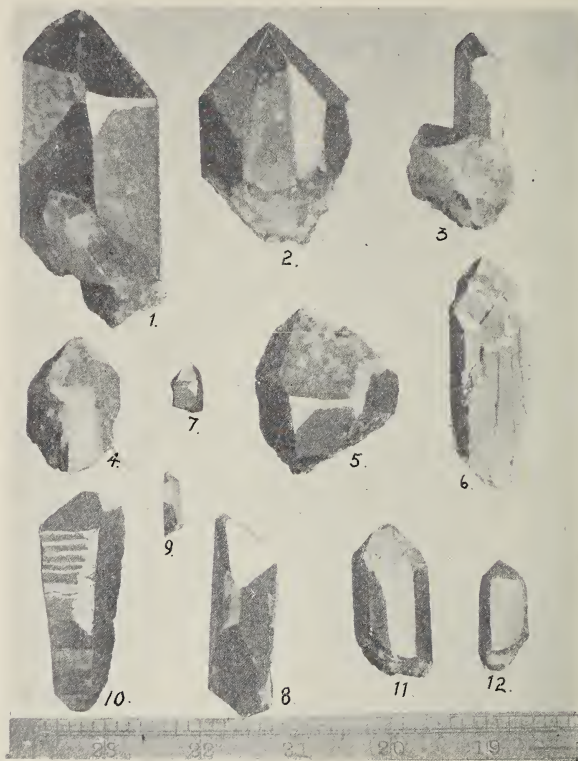

Group of quartz crystals from Pala and Rincon, San Diego County, California.

and  $e(50\bar{5}1)$  faces; while the other member has developed only the  $\Gamma(40\bar{1}1)$  face.

In figs. 3a, 3b and 1a, 1b are given orthographic and clinographic projections of the two crystals numbered 3 and 1 respectively in the group of crystals above, showing the relative size and positions of the rare faces.

Figs. 2 and 4 also are distinctly marked twins; the one shown by a joint or break along the prism face, the other by a distinct difference in opacity of the two members.

Deformation, or abnormal growth, is also met with. Fig. 6 is an example of parallel growth, while figs. 8, 9 and 10 are distorted forms. In fig. 10 the crystal is placed with its major axis perpendicular to the paper, so that one is looking down on the apex of the pyramid.

Corrosion or etching of the pyramidal faces, while those of the prism are unaffected, is illustrated in figs. 11 and 12.

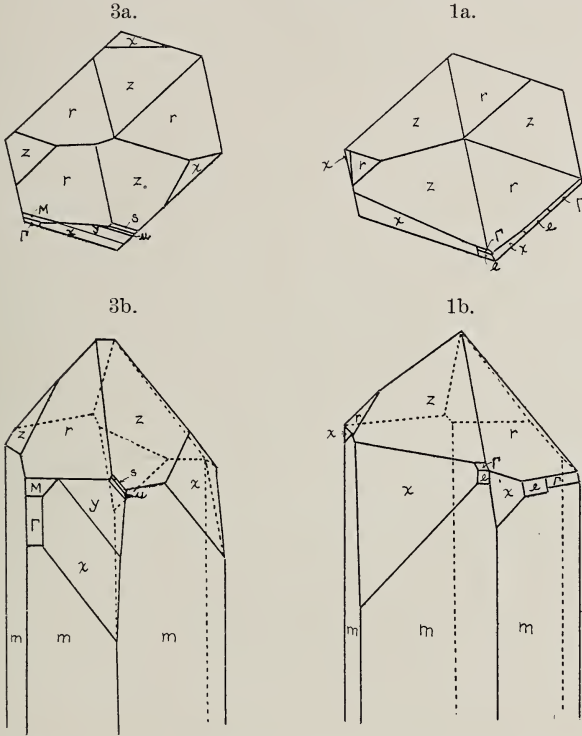

Orthographic and clinographic projections of quartz crystals from Rincon, California, from figs. 3 and 1, p. 126.

One other extremely interesting point is that of the evidence of secondary crystallization, as shown by the filling up of the  $x$ ,  $y$ , and  $e-M$  faces to a level, or nearly so, with the prism face. This is well exhibited in figs. 5 and 10.

While the  $s$  face occurs rather commonly elsewhere, the  $x$  and  $y$  faces are of much rarer occurrence. It is therefore worthy of note that upon the crystals of this region it is the trapezohedral faces that develop most frequently, while the  $s$  face, the trigonal pyramid, is seldom found.

Stanford University, California.

ART. XVII.—*On the Radio-active Properties of the Waters of the Springs on the Hot Springs Reservation, Hot Springs, Ark.*; by BERTRAM B. BOLTWOOD.\*

THE Hot Springs Reservation is situated in Garland County, Ark., on the western slope of the Hot Springs Mountain, a spur of the Ozark Range. On the grounds of the Reservation the thermal waters rise through over fifty separate sources, and the total flow is estimated to be over 800,000 gallons in twenty-four hours.

During the summer of 1904, at the direction of the Secretary of the Interior, a thorough examination of the waters of these springs for radio-active properties was carried out by the writer. Samples of the waters were collected at the springs, some in July by Dr. Joseph H. Pratt, and the remainder in August by Mr. Martin A. Eisele, Superintendent of the Reservation. The samples were taken directly from the springs and were immediately introduced into large, glass receptacles. These receptacles were tightly corked and the corks were covered with a heavy coating of hot sealing-wax, thus hermetically sealing up the sample contained within them. The samples were shipped by express to New Haven, Conn., where the tests described in this paper were conducted. The samples were collected and shipped in separate lots of six each, and the tests were carried out as soon after the receipt of the samples as possible. The average time required for the transportation of the samples by the express companies was about seven days.

The constituents tested for were radio-active gas (emanation) and radio-active solids. An examination was also made of the tufa deposited by certain of the springs in order to determine whether this contained any radio-active substances.

The methods employed in the determination of the radio-active gas contained in the water, and in the determination of the presence of radium salts in solution, have already been described† in an earlier paper. The plan there followed of expressing the activity of the dissolved radium emanation in terms of the uranium equivalent has been modified to the extent of introducing a correction for the proportion of radium emanation lost by the pulverized sample of uranium mineral used for determining the standard.‡ Since the quantity of

\* Published with the permission of the Secretary of the Interior.

† This Journal, xviii, 378, 1904.

‡ A method for determining the proportion of emanation which spontaneously escapes from the cold, finely-ground mineral has been described in the Phil. Mag. (6), ix, 599.

radium associated with a definite weight of uranium in a radio-active mineral has been shown\* to be a perfectly definite and unvarying quantity, this method of expressing the activity of a given quantity of emanation affords a convenient and accurate standard for the comparison of samples of water from different sources.

Samples of water from forty-four of the different hot springs were examined. The properties of the gaseous, radio-active constituent were found to be identical with those of the radium emanation. The activity of the gas fell to one-half value in about 3.9 days and the active deposit, after two hours from the start, had a half-value period of twenty-eight minutes.

In the following table are given the quantitative results of the examination of the waters. The first column gives the laboratory number of the sample, the second column contains the number representing the activity of the gas actually obtained from one liter of water expressed in terms of the uranium standard,† the third column gives the number of days which transpired from the time of collecting the sample to the time of testing the water, and the fourth column gives the initial activity of the water (per liter) as calculated from the equation:  $I_0 = Ie^{-\lambda t}$ .

Laboratory number.	Observed activity per liter water $g \times 10^{-4}$ uranium.	Days from time of collection.	Calculated initial activity.
22A	0.9	8	3.7
23A	3.8	7	14.4
24A	1.8	7	6.8
25A	3.9	7	15.1
26A	8.4	7	31.9
27A	0.4	8	1.6
29A	6.3	7	23.9
30A	12.5	7	49.0
32A	7.6	7	28.9
33A	3.1	7	11.8
34A	7.7	7	29.3
35A	17.2	7	65.4
36A	14.4	7	54.7
37A	2.1	9	10.3
38A	0.9	7	3.4
39A	8.5	9	41.6
40A	2.6	10	15.3
41A	1.3	10	7.7
43A	1.3	7	4.9

\* Boltwood, this Journal, xviii, 97; Phil. Mag. (6), ix, 599.

† The number denotes the weight in grams of the quantity of uranium in a radio-active mineral which is associated with a quantity of radium, the total emanation from which would be equivalent to the emanation obtained from one liter of the water.

Laboratory number.	Observed activity per liter water $g \times 10^{-4}$ uranium.	Days from time of collection.	Calculated initial activity.
44A	5.8	7	22.0
45A	0.9	9	4.4
46A	1.8	9	8.8
47A	8.1	6	23.5
48A	1.3	7	4.9
50B	1.7	9	8.3
51B	1.3	8	5.3
52B	0.17	6	0.5
54B	0.4	7	1.5
55B	2.1	7	8.0
56B	0.2	8	0.8
59B	3.4	7	12.9
60B	1.8	7	6.8
61B	4.9	6	14.2
62B	3.9	7	14.8
63B	25.6	7	97.3
64C	9.0	6	26.1
65C	5.0	6	14.5
66C	10.5	6	30.5
67C	2.5	8	10.2
68C	9.0	6	26.1
69C	13.8	6	40.0
70C	91.6	6	265.6
71C	3.6	7	13.7
72C	3.9	7	14.8

#### *Radio-activity of Water on Standing.*

A sample of water No. 39A was sealed up in a large receptacle holding about twelve liters and allowed to stand undisturbed for thirty-two days. At the end of this period the activity of the gases contained in the water was tested. The activity was very low and was not greater than the natural residuum which would remain from the emanation originally present. This indicated that the water contained no radium salts in solution.

A quantity of water No. 70C, from which the gas had been removed by boiling after acidifying with acetic acid, was allowed to stand in an open vessel for two days, and was then sealed up for twelve days longer. At the end of this time it was tested for radio-active gases, but no radio-activity could be detected in the gas which was obtained during the second boiling operation. This also indicated the absence of radium salts in solution.

#### *Residues from Water.*

About twenty liters of water from sources No. 39A and 67C were evaporated to dryness and the residue tested in the elec-

troscope. No indication of any activity in the solid substance could be obtained. The mineral salts in the residue were converted into chlorides, dissolved in water, and the resulting solution was sealed up for thirty days. The accumulated gases were boiled off and tested. The observed radio-activity was too slight to measure with any accuracy, and corresponded at most to the smallest detectable trace of radium salts in the waters.

*Tufa from Springs.*

On issuing from the ground a number of the springs form a deposit of "tufa," consisting chiefly of carbonate of calcium. A sample of this material weighing 100 grams was dissolved in dilute hydrochloric acid and the gas evolved was conducted into a strong solution of sodium hydroxide. A small residue of gases not absorbed by the sodium hydroxide solution was examined in the electroscope. The radio-activity of these gases indicated that the quantity of radium present in the tufa was less than one-millionth of the quantity of radium associated with an equal weight (100 grams) of uranium in pitchblende.

*Gas from Springs.*

Samples of the gases which rise with two of the springs were tested under conditions identical with those under which the gas obtained on boiling the water was tested. The measurements were carried out eight days after the gases had been collected at the springs, and the activity of the gases was found to be less than that of equal volumes of gases obtained by boiling the waters from the same springs.

*Water from Cold Springs.*

In addition to the hot springs, there are on the grounds of the Reservation two cold springs, situated on the northern slope of Hot Springs Mountain, and issuing from the earth about 800 feet from the nearest hot spring. An examination of the waters of these springs gave the following results :

Laboratory number.	Observed activity per liter water $g \times 10^{-4}$ uranium.	Days from time of collection.	Calculated initial activity.
73D	6.0	6	17.4
74D	18.1	10	106.8

*Discussion of Results.*

One of the most interesting results of the present investigation is the demonstration of such marked variations in the activity of the water from such a closely related series of springs. The temperature of the different springs varies from

35° C. to 64° C. and the total solids in the waters vary from 170 to 310 parts per million,\* while the average amount of solids in all the springs is between 275 parts and 280 parts. In only a few of the springs do the solids fall below 270 parts or rise above 290 parts per million.

In their general chemical characteristic the waters from the different springs show a marked resemblance to one another, and such a great variation in the activity of the different waters was entirely unexpected. It will be noticed that the most active spring water (No. 70C) is over 500 times more active than the least active (No. 52B).

That these variations were in no way due to the conditions under which the particular samples were collected and tested was shown by the fact that duplicate samples collected at different times and by different persons gave closely agreeing results.

All of the hot springs are situated on a narrow strip of land about 500 yards in length. No connection can be discovered between the location of the springs and their radio-active properties. The more active springs are widely scattered and adjacent springs usually show great differences in the radio-active properties of their waters. As a general summary it can be stated that it has been found impossible to establish any connection between the temperature, flow, location or chemical composition of the waters of the springs and the observed differences in the radio-active properties.

Another interesting point is brought out by the relatively high activity of the two cold springs as compared with the least active hot springs. It will be noted that the second most radio-active water was that from the cold spring No. 74D. This would seem to indicate that the thermal qualities of the waters and their radio-active properties are due to quite independent causes.

The results of this investigation demonstrate the necessity of the quantitative examination of the water from each separate spring in order to obtain a definite knowledge of the radio-active properties of the waters derived from a number of adjacent, individual sources.

139 Orange St., New Haven, Conn., June, 1905.

\* A very complete chemical examination of the waters of these springs has been made by Mr. J. K. Haywood of the U. S. Department of Agriculture. The results have been published under the title of "The Hot Springs of Arkansas," Senate Document No. 282, Government Printing Office, Washington, 1902.



ART. XVIII.—*On the Genesis of Riebeckite and Riebeckite Rocks* ;\* by G. M. MURGOI, Bucharest.

RECENT investigations have shown that riebeckite rocks are not uncommon; new occurrences are being discovered, and in old localities alkali rocks described as containing black or blue hornblende are often identified as really containing riebeckite. These rocks are attracting special attention, because of the presence of this rare sodium-iron amphibole, and because some of them are the most acid of alkali rocks, rising to 78 per cent in  $\text{SiO}_2$  (according to the analyses of Butureanu, Ludwig, etc.) and to 10 per cent in  $\text{Na}_2\text{O}$  and  $\text{K}_2\text{O}$ .

I have discovered these interesting rocks in Dobrogea at Jacobdeal and Piatra Rosie† (at the mouths of the Danube), and was able to study *in situ* their geological characters and relations to the enclosing rocks. I have also compared them in the laboratory with similar rocks from other localities. A résumé of the facts in Dobrogea is as follows:

In the Paleozoic formations composed of quartzites, sandstones and conglomerates, calcareous and argillaceous shales and crystalline limestone, the following rocks are found as intrusive masses: various kinds of granites, microgranites, quartz and orthoclase porphyries, diorites and olivine gabbros, etc., which in general occupy the anticlines of the sedimentary formations. All the foregoing rocks and the Triassic sandstone and limestone are penetrated by dikes of microgranites, porphyries, diorites, pearl and porphyritic diabases, etc. It has been proved satisfactorily that there have been two epochs of volcanic activity: Paleozoic (pre-Permian) and Triassic. Sometimes the mesocratic rocks of the two series are very similar and could easily be confused one with another, if the field relations are not correctly interpreted.

The rocks of the first volcanic epoch, usually alkali rocks (Mrázec), show a consanguinity obvious in the field and confirmed by investigation in the laboratory, Dobrogea being in this respect a very interesting petrographical province. Riebeckite rocks, however, are confined to the hills of the western Dobrogea in two of the anticlines of the slightly metamorphosed argillaceous shales and sandstones. The anticlines have a northwest-southeast strike and in the region of Carjelari run

\* Preliminary communication read before the Geological Society in Philadelphia, December, 1904.

† G. M. Murgoci, *Ridicări geologice în N. Dobrogei*, Bull. Soc. Inginerilor de mine, 1898, Bucuresti.

Among the specimens that I collected in the quarries of Jacobdeal, Prof. L. Mrázec recognized riebeckite granite and described it in: *Note préliminaire sur un granite à riebeckite and aëgirine des environs de Turcoaia (Dobrogea)*. Ibidem. 1899.

together, forming, by their uniting cores, one single large mass of eruptive rocks.\* In this zone, granites (soda-granites, nordmarkite, and quartz syenite) microgranites and granite porphyries (granophyre and paisanite) and typical quartz and orthoclase porphyries are found together in the same or neighboring localities. One may remark, according to the present exposures and topography of these rocks, that the porphyritic masses, with or without riebeckite, occupy a larger area at the surface than the granite (in the proportion of 3:1); the region is much eroded, the layers are almost vertical and the porphyritic facies occurs in the western part of the granite zone. In this case the porphyritic rocks can not be regarded only as marginal facies of the granite massif. On the other hand, the various rocks with riebeckite form large streaks and patches (*schlieren*) mixed at random in the massives, with similar masses without riebeckite, but very acid and poor in black constituents. Some masses, especially those of more basic character, were obviously homogeneous and polygeneous inclusions. Although there are many quarries in the two hills of Jacobdeal and Piatra Rosie, which furnish exposures, dike rocks of pegmatitic, aplitic or lamprophyric characters could not be found. In one place of the type of nordmarkite occurs in such a manner that it might be regarded as a dike terminating abruptly upwards; the same rock, however, occurs in the neighborhood as polygeneous inclusions.

Owing to the absence of obvious dikes, it is impossible to determine the order of the ascension and consolidation of the magmas forming these various rocks. Their occurrence and structure, their study by chemical and petrographical methods and the relations between them, reveal to us only local phenomena which occurred during the consolidation of the large molten mass.

It is well known what a tendency the alkali magmas have to differentiate and especially in massives of sodic rocks; this fact can be very well confirmed, as shown by numerous researches. This phenomenon, often described in the alkali rocks of the trachyte-syenite series (especially in nephelite syenites), is also mentioned in massives with riebeckite rocks of the granite-rhyolite series, when studied over large areas. There might be cited the classic researches by Brögger (Christiania region), Tenne (Yemen), Washington (Essex County, Mass.†), Lacroix

\* See the geological map by R. Pascu, *Moniteur du Petrole roum.* 1904. Bucharest.

† In the neighborhood of Boston, "the glaucophane granite" studied by White has been determined by Washington as riebeckite granite (*Journal of Geology*, vol. vi, No. 8 and fol., 1898-1899), and among the specimens which I possess through the kindness of Prof. Kemp, I was able to distinguish riebeckite granophyre, paisanite, interesting inclusions, etc. Even White described gradual variations of structure and composition in one and the same massif. *Proc. of the Boston Soc. of Nat. Hist.*, 28, No. 6, 1897.

(Madagascar, Corsica, Colorado), Pelikan (Socotra, etc.), Har-ker (I. of Skye, etc.), and many interesting remarks in Rosenbusch's writings, where he discusses amphibole and pyroxene granites, etc. The very interesting example is given by Lacroix\* in the rhyolite of Somalis, where schlieren of microgranite were observed in the rhyolitic mass.

I have recently compared my riebeckite rocks with those from Scotland, Wales and Massachusetts, and have been able to extend and generalize the conclusions of Lacroix† deduced from observations on different granites with riebeckite and ægirite, and I would include also microgranitic and porphyritic types from granite and quartz syenite series. Summarizing the observations, we may emphasize the characters which reveal to us the genesis of the riebeckite rocks as follows:

1. The massives with riebeckite rocks are characterized by a great variety of types rich in soda as schlieren or as dikes. In such massives there is very frequently a tendency towards a pegmatitic or miarolitic structure in some of the schlieren, and a fluidal or microgranitic one in others. Schlieren with a protoclastic structure may be observed in the holocrystalline types and also in porphyritic ones.

2. Variations occur not only in the structure, but also much more in the constituents, especially in the dark-colored ones, which are, however, almost always amphibole, or pyroxene, or both, often grown together or zonal. The amphibole in the most acid rocks is of the arfvedsonite-riebeckite group, in the relatively basic ones it is of the kataforite-barkevikite group; the pyroxene is ægirite or ægirite-augite. Ægirite nearly always accompanies riebeckite; but while ægirite occurs often as well developed, more or less idiomorphic, crystals, the large patches of riebeckite have, as is well known, a spongy, poikilitic structure with a well marked allotriomorphic development. The character of its occurrence, in even granular rocks and in porphyries, shows that riebeckite has been formed continually during the whole time of the consolidation of the magma. It is found as microlites, in small and minute prisms and needles or fibers, included in other constituents such as feldspar, quartz, etc.; as large dark-blue crystals grown together with other minerals, such as ægirite, zircon, and pyrochlore; as patches cementing feldspar and even quartz; as poikilitic shreds and beads in the groundmass of the porphyritic rocks; further it is found in miarolitic cavities, in pneumatogeneous inclusions, in the cracks and druses of the rocks filled by pegmatitic masses, etc.

\* A. Lacroix, *Les Rhyolites à ægirine and riebeckite de Somalis.* C. R., Ac. Sc. Paris, cxxviii, 1899.

† A. Lacroix, *Materiaux pour la Minéralogie de Madagascar.* Nouvelles Archives du Muséum d'Hist. Natur. IV<sup>e</sup> s, 1902, p. 164, etc. See also *Les travaux de M. A. Lacroix*, 1903.

3. The riebeckite rocks represent in the massives the pegmatitic varieties, consolidated under special physical conditions, riebeckite being a mineral which requires pneumatolitic conditions for its formation. All petrologists, who have studied riebeckite rocks, mention pegmatitic, micropegmatitic or grano-phyrlic structures as being characteristic of them. Brögger\* has remarked that riebeckite (and arfvedsonite) occurs especially in rocks rich in quartz (over 60 per cent, according to the analyses of Butureau† and E. Ludwig‡, up to 78.5 per cent), and on the other hand, while ægirite occurs in almost all the rocks of the Christiania region, riebeckite appears only in those which indicate high pressure, and is wanting in those pegmatitic dikes, where ægirite is the most frequent mineral. Flink & Bøggild§ have described riebeckite ("type II of arfvedsonite," Riebeckite?) in the pegmatitic schlieren of Greenland (Narsarsuk), which are also very rich in ægirite. It must be noted, that the syenite pegmatites of Narsarsuk occur not as veins or dikes, like those from Christiania, but "there are dike-like syenite formations, which differ from the ordinary typical syenite, in having as chief elements constituents, rich in iron, of the pyroxene and amphibole series. There can be no question of dikes or deposits, . . . . the minerals show that the pegmatitic formations have arisen simultaneously with the bulk of the rock." Hedde, Prior, König, etc., have also studied perfect crystals from quartz dikes or miarolite cavities only. On the other hand, Lacroix|| has described very characteristic pegmatites, containing the only large crystals of riebeckite known, which come from Colorado (San Petro's Dom), Corsica, Madagascar, etc. The riebeckite crystals occur in the pegmatite-like black tourmaline in common pegmatites; the riebeckite pegmatites pass over gradually into granitic or microgranitic rocks.

\* W. C. Brögger, *Eruptivgesteine der Kristiania Gebietes*, i, 1894, pp. 36, 39, 184, 186, etc.

† V. Butureau, *Sur la composition des granite à Riebeckite de Jacobdeal, Dobrogea*. *Annales scientifiques de l'Université de Jassy*, 1893. An analysis of riebeckite too.

‡ A. Pelikan, *Petrographische Untersuchungen von Gesteine der Inseln Sokotra, Abdel Kûri und Semba*. *Denkschriften der Math. Naturw. Klasse der k. Akademie Wien*, 1902, lxxi. Analyses by Prof. E. Ludwig.

§ J. Flink, O. Bøggild and Chr. Winter. *Untersuchungen über Mineralien von Julianehaab*. *Meddelelser om Groenland*, 1899, 24. Reference in *Zeitschr. f. Kryst. and Min.* xxxiv, 1901.—N. v. Ussing (*ibidem*, 1894, Abstract in *Neues Jahrbuch f. Miner., etc.*, 1901, 45) cites riebeckite also in syenite.

|| A. Lacroix, after the communications to *Academie de Sciences*, Paris (Colorado, *Comptes Rendus* cix, 1889, Mt. Saber, C. R. cxxviii, 1899) returns to the Corsican rocks (described first by Le Vevier, C. R. cix, 1899, and Nentien, *Mem. carte géol. France*, 1897) in *Minéralogie de la France*, i, 695, and recently discusses the general question in *Matériaux pour la Minéralogie de Madagascar*. *Nouv. Archives du Muséum d'Hist. Natur.* 1902–1903. See also: *Les travaux de M. A. Lacroix*, 1903.

4. I may further emphasize the similarity of riebeckite, in its occurrence and petrographic characters, with the tourmaline from tourmaline granites, aplites, etc. The poikilitic structure of the large crystals, hypidiomorphic and allotriomorphic forms in one and the same rock, are characters common to both riebeckite and tourmaline. The rocks with tourmaline are very alkalic like those with riebeckite\*; riebeckite like tourmaline eliminates other black constituents such as biotite. The riebeckite rocks have their special accessory mineral, zircon, in the same way that tourmaline rocks carry cassiterite.†

5. The quartz and the feldspars (which are orthoclase either with patches of soda-microcline or with albite in micropertlite intergrowths, all more or less idiomorphic) contain many inclusions of riebeckite, zircon, and liquids with bubbles and cubes of common salt.

6. A great deal of zircon accompanies the riebeckite; Brögger, Washington, Mrazec, Lacroix and Souza Brandão (1905) emphasize this fact. Lacroix found as much as 7.5 per cent zircon in the rocks of Madagascar. The barkevikite rocks, on the other hand, contain much titanite. It is worthy of mention in this connection that Brögger‡ states that in the middle of a dike of quartz-lindöite (of west Åker, Christiania) riebeckite occurs with much zircon, crystallized after riebeckite, whilst at the salband there is katoforite and ægirite without zircon; on the other hand, zircon is very frequent in the pegmatitic dikes at the Christiania region. Zircon and titanite have been formed during the whole time of the consolidation of the magma-like riebeckite.

7. In miarolitic cavities of these rocks fluorspar, galena, zircon (spinel?) and riebeckite have been found together. Brögger, Lacroix and Washington state that fluorspar is often a constituent of the rocks rich in soda, which contain ægirite and riebeckite, and in general I have also found it in many of the rocks of the region studied by me and in those of other places, such as in the Quincy granite, the trachyte of Berkum near Remagen, the microgranite of Ailsa Craig, etc.

The occurrence of fluorspar in certain granites is very important from a theoretical standpoint; in them fluorspar occurs as small crystals, often microlites, grown together with or included in the ægirite; riebeckite when inter-grown with ægirite is quite free from such fluorspar inclusions, but may contain small pockets of rare carbonates (parasite?). In general

\* The complicated composition of riebeckite is well known. I know of six analyses and no two alike; the differences can not come from mistakes only. On the other hand, riebeckite contains Fl also.

† A. Lacroix, *Materiaux de Madagascar*, loc. cit., i, p. 89.

‡ W. C. Brögger, loc. cit., pp. 137, 138.

ægirite granite carries much fluorspar; in the pure riebeckite granite, on the other hand, it is almost entirely wanting. Brögger\* mentions the occurrence of much fluorspar and ægirite on the salbands of the grorudites of Omholtsaeter, which are apophyses of the soda-granite of Kongsberg and in relation with the genuine pegmatitic dikes and akmite granite of Rundemyr. According to Rosenbusch† in this massif there occurs also riebeckite granite.

Brögger‡ described also a peripheral transformation of barvikite into ægirite and lepidomelane with a rich accompaniment of fluorspar, and he explains this change as due to pneumatolitic action at the end of the consolidation of the hydato-pyrogenous mass or immediately after it. This may be possible in the pegmatitic dikes of Christiania, where Brögger has proved four phases of pneumatolitic action, ægirite being formed in the third phase. If the rock contains both riebeckite and ægirite, often grown together with fluorspars and carbonates, I believe the process to have occurred in another manner, riebeckite and ægirite being primary, fluorspar and carbonates also. It is well known what complicated relations of zonal and other intergrowths there are between the pyroxenes and amphiboles when they occur together, especially in ægirite-riebeckite rocks; some petrologists have considered the ægirite as a transformation product of riebeckite, and others have taken the riebeckite for a secondary product of ægirite. Among other examples there might be mentioned the one furnished by Cross§ in his description of amphiboles from Silver Cliff, Col., and another by Bøggild (loc. cit.), who has found in the pegmatitic schlieren of Narsarsuk arfvedsonite covered by secondary ægirite, and in the same rock riebeckite with a core of ægirite. Most petrologists state, however, that riebeckite and ægirite are primary in their rocks. Without denying the later transformation of riebeckite into ægirite, a fact easy to imagine considering that their composition is similar and that ægirite seems to be the more stable form, I believe, however, that in general riebeckite and ægirite are both primary in rocks, and if transformations have taken place, they must have occurred before the consolidation of the magma.

The genesis at the same time of these two minerals of almost identical composition is a very interesting phenomenon and deserves to be taken for a moment into consideration: Steen-

\* W. C. Brögger, *ibidem*, p. 190.

† H. Rosenbusch, *Massige Gesteine*, II ed., p. 59.

‡ W. C. Brögger, *Die Mineralien der Syenit-pegmatitgänge von Norwegen*. *Zeitschrift der Krystallographie und Mineralogie*, 16, 1890. The first part is devoted to the rocks of that region.

§ Whitman Cross. Note on some secondary minerals of the amphibole and pyroxene groups. *This Journal*, xxxix, 1890.

strup\* by melting arfvedsonite has obtained ægirite; Doelter by melting gastaldite in sodium fluoride has also obtained ægirite or akmite, but without fluoride there resulted an amorphous mass. These two experiments and many others have shown that ægirite and pyroxene can originate in molten masses under ordinary conditions. This is, however, not the case with amphiboles, and recently Vogt† has demonstrated again that amphiboles require high pressure for their formation. Considering the facts more closely, for a medium to be capable of giving rise to the riebeckite or ægirite molecule (which may be expressed by  $\text{Si}_5\text{O}_{15}\text{Fe}'''\text{Fe}''\text{Na}_2$ ‡), there appear to be two chief factors necessary, namely *pressure and mineralizers*§. The obvious fact that these two minerals can originate at the same time in a magma, shows that there cannot be much difference between their coefficients of solubility, i. e., their capacity for forming saturated solutions in the molten mass; on the other hand, the melting point of these minerals (æg. =  $940^\circ$ , rieb. =  $945^\circ$  C. according to Doelter) is not different under ordinary circumstances and cannot vary much if the circumstances vary in the same way for both minerals. The structure of the riebeckite-ægirite rocks and the mode of occurrence of these minerals support the statement of Höpfner verified by Vogt (l. c.), that pressure has not much influence on the order of separation of the minerals in a magma and on the composition of eutectic mixtures. I may add, with respect to the ideas of Loewinson-Lessing,|| that pressure alone is not sufficient to force a dimorphous substance to crystallize in one form rather than in another, although one may have a smaller true molecular volume than the other. According to this general dynamic rule, ægirite, with the smaller molecular volume, should be the characteristic mineral of the abyssal rocks rich in soda. Observation and experiment contradict this: ægirite can form under ordinary pressure and occurs much more in hypabyssal and volcanic rocks than in abyssal ones; riebeckite has not been obtained at ordinary pressure, but it occurs in trachyte with fluorspar and in rhyolites, which clearly show evidences of a pneumatolytic process. On the

\* The best argument for the primary existence of the ægirite is its occurrence, in the same rock, with little thin needles of riebeckite, which could not resist even the slowest and slightest action of transformation.

† T. H. Vogt, Die Silikatschmelzlösungen. Mem. of the Acad. of Christiania, 1904.

‡ This formula given by König, and confirmed by Butureau on the Dobrogean riebeckite, agrees very closely with the analyses of ægirite by Doelter.

§ This question in particular I intend to take up again, after some experiments, with more detail.

|| F. Loewinson-Lessing, Studien über Eruptivgesteine. Memoires du Congrès Geol. de St. Petersburg, 1897, p. 325 f.

other hand, the schistose metamorphosed riebeckite rocks of Gloggnitz and Alter Padroso, etc., show no transformation in this respect, ægirite and riebeckite having the same character and both being primary, often grown together or zonal, as in the unpressed eruptive rocks. We are forced accordingly to invoke, besides the composition of the magma and the pressure, also that important agent, which has left its traces in the components of these rocks, the *mineralizers*.\*

If now,  $p$  represents the conditions of pressure, which may be unity, or one atmosphere, and  $m$  the mineralizers†, which may be much reduced, of a magma in which the whole substance  $\text{Si}_2\text{O}_5, \text{Fe}''', \text{Fe}'' \text{Na}_2$  may crystallize as ægirite, then  $P$  and  $M$  may be the conditions of minimal pressure and mineralizers in which the same substance may crystallize as riebeckite. One can imagine that between the points  $p, m$  and  $P, M$  there may be a large number of stages ( $P_x, M_y$ ), where there can arise a variable percentage  $A$  of ægirite to  $B$  of riebeckite, more or less respectively, accordingly as a particular stage is nearer to the point  $p, m$  or  $P, M$ .‡ The variation of the medium  $\mu$  (composition of magma + mineralizers) influences in large proportion the phenomena, and the representative curve of the phenomena  $f(m, p)$  is displaced in plane, and for a definite value of  $\mu$  we meet with a critical point for the formation of riebeckite; in a magma below this limit,—riebeckite can no longer form under any pressure by the given mineralizers. And according to these different conditions of a magma, pressure and mineralizers, there can originate in one and the same igneous mass and at the same time of consolidation rocks with riebeckite only, rocks with riebeckite and ægirite in all proportions, and those with ægirite alone.

In this way we can explain the relations which have been observed between riebeckite, ægirite and fluorspar. The min-

\* F. Loewinson-Lessing in his interesting discussion (l. cit. p. 359) admits the necessity for pressure and an active gas (he means water) for the formation of amphiboles. The experiments which he has made by melting pyroxenes and amphiboles in an atmosphere of water vapour have not been successful in producing hornblende. It would be very interesting to know what would be the result of an experiment in a fluorine atmosphere under a high pressure! I may note that the only synthetic hornblende (with 2%  $\text{Na}_2\text{O}$ ) was obtained by Chrustschoff (1891) in sealed tubes in the presence of water at high temperature.

† That is to say, the capability of the mineralizers for forming minerals.

‡ This question is a very complicated one and we do not know how many substances and how many phases there are at a given moment. We may, however, imagine the simplified case of  $n$  substances (magma, iron-sodium silicate and fluorine mineralizers) and  $n+1$  phases (magnatic solution, riebeckite, ægirite and gas). The most analogous example is to be found in the crystallization of calcite and aragonite (or conchite) from a dilute solution at varying temperatures. See: Beiträge zur mineralogischen Kenntnis der Kalkausscheidung im Tierreich von Agnes Kelly. Jenäischer Zeitschrift für Naturwissenschaft, 1900.



eralizers have not a catalytic action only; it has been demonstrated several times that they have an active part in the consolidation of magmas and in the formation of minerals. Accordingly, in a magma of a definite composition containing mineralizers and under a sufficient pressure to give rise to riebeckite, a part of the mineralizers (F1, Na, Ti, Zr, etc.) play an active rôle in the formation of the riebeckite, entering also into its composition.\* Where there is low pressure and the mineralizers are not appropriate for the formation of riebeckite, ægirite is formed, and the mineralizers, which it does not require for its production, react on the magma and among themselves, giving rise to other characteristic minerals with the form and paragenesis which we have seen above.

8. The former presence of high pressure and abundant active mineralizers can be clearly deduced from the study of riebeckite rocks, as may be seen from the works of Brögger, Lacroix and others. Lacroix, in particular, concludes from the presence of fluorspar, galena, zircon, and the pseudomorphic changes and alterations undergone by riebeckite and ægirite, that emanations characterized by fluorine and zirconium were active at the moment of consolidation, and that in riebeckite rocks zirconium plays the part of tin in alkali rocks with tourmaline. He, like Brögger, assumes a powerful manifestation of post-volcanic activity, which in some cases has produced deposits of cryolite, as at St. Peter's Dome, Colo., and in Greenland, or marked transformations in the structure and composition of the rocks, as in the rhyolite of Somalis.

According to my researches in Dobrogea the post-volcanic activity is almost wanting in massives with many schlieren and much variation in the kinds of rocks. No pegmatitic dikes or veins like those in Greenland or Norway have been seen in the many quarries in Jacobdeal and Piatra Rosie, and the contact metamorphism of the neighboring rocks is very small. I may add that, in this respect, the alkali granite of Măcin and Pricopanu shows much greater contact phenomena and pneumatolitic post-volcanic activity. In the cracks of the Jacobdeal granite I have found only a few spots coated with little crystals of quartz, hæmatite, very rarely fibers of crocidolite, and beautiful dendrites of ferromanganese hydroxides like those from the Quincy granite.

\* This deduction finds a certain verification in the composition of riebeckite; unfortunately the existing analyses are very unsatisfactory. In a recent conversation with Dr. Tassin, he informed me that he had found fluorine in a riebeckite which he is analyzing. Amphiboles with fluorine are known; for example, see the pargasites, etc., in the table of analyses by Hintze, and the hornblende from Grenville (Quebec) with 2.8 per cent F1 (Harrington, B., this Journal, 1903, p. 392). Perhaps the loss in König's (riebeckite) analyses (made, he says, with all precautions) may be fluorine.

The pneumatolitic elements have been in the magma and reacting rather during the time of the consolidation of these riebeckite rocks than later (as I have attempted to show above). The study of the inclusions of riebeckite granite give further support for this statement. Such inclusions have been mentioned by Brögger, Washington, and White, but do not seem to have aroused much interest. I have found many inclusions in the granite of Jacobdeal and Piatra rosie, and have observed some in the Quincy granite. They may be classified as follows:

Homogeneous inclusions, that is aggregates of riebeckite which are often fibrous (crocidolite?), with spongy quartz, zircon and hematite; the riebeckite forms large prisms but is not well developed.

Pneumatogenous inclusions, that is, those formed by mineralizing vapors which are porous or hollow, with a great deal of fluor spar, galena, pyrites, pyrotite, mispikel, hematite and many earthy looking minerals which are certainly alteration products of other minerals; riebeckite and angite-ægirite are rare, feldspar is more frequent and there is very little quartz.\*

Polygenous and enalogenous inclusions formed by varying combinations of processes, of variable size and composition; in such inclusions occur large crystals of orthoclase and albite, pyroxenes, amphiboles (but no riebeckite), astrophillite, mica, etc. Through the assimilation of these inclusions local variations in the composition and structure of the granite arise, and rocks are formed (endopligenous inclusions) of the types of nordmarkite, akerite, grorudite, paisanite and even quartz-pulaskite and sölvbergite. The occurrence of these different rocks as inclusions is very striking in the many quarries of Dobrogea and also in specimens from Quincy, Mass†. In many of these rocks riebeckite is replaced by katoforite or barkevikite, and this fact can be explained, in my belief, by variation in the composition of the magma under definite limits, while pressure and mineralizers remain the same as in the main mass.

Lacroix has described from Ampasibitika contact rocks of a riebeckite granite (perhaps in part inclusions) and states that they contain the same minerals, riebeckite—sometimes in pseudomorphic forms—ægirite, fluor spar, spinel and zircon, which occur in the granite. The contact of Dobrogea does not show marked metamorphism; there are epidote, pyroxene and amphibole hornfels, but without riebeckite, and it may be

\* G. Murgoci, *Minerale din Dobrogea*. Publicatiunile Soc. Naturalistilor, 2, 1902. Bucharest.

† I may further remark that the analyses of an enclosure in granite of Pigeon Hill, by Washington (loc. cit.), does not differ at all from the akerite analyzed by the same investigator. *Journal of Geology*, 1898-99.

added that in general this mineral does not occur in genuine schists. The well known forellengranulite (orthogneiss) of Gloggnitz,\* the riebeckite granulite of Alter Pedroso in Portugal,† are surely eruptive rocks,‡ and their characters are quite similar to those summarized above. Lacroix§ mentions genuine schists with riebeckite from Corsica, from the Alps of Savoy, from Bulgar Dagħ in the Taurus, etc., which occur associated with glaucophane schists. It is to be noted that the riebeckite of these rocks occurs as needles and fibers, radially spherulitic or lenticular, and it has always been compared with the tourmaline of luxullianite. In some rocks, especially holocrystalline ones, needles and fibers of riebeckite(?) are found in such relation to large crystals of riebeckite or ægirite, that they look like secondary products and are quite similar to those described by Cross, Lane, White and Washington. Cross has identified the blue amphibole of Silver Cliff with the crocidolite of Lacroix¶; perhaps it is the case that all these kinds of blue amphiboles should be referred to crocidolite.¶ Crocidolite seems to be different from riebeckite both in occurrence and composition; its genesis in riebeckite rocks seems to show that it should there be primary, indicating circumstances which Weinschenk presupposes in piezocrystallization; and many characters of crocidolite are in accordance with this hypothesis, as S. Franchi has deduced for the glaucophane (and crocidolite) schists.

From the above mentioned characters of riebeckite and of the rocks in which it occurs, we may, to some extent, deduce the circumstances under which these rocks have been formed, especially those from Dobrogea.

The magma which has given rise to the riebeckite rocks ascends from an alkaline magma basin, from which it is derived by a process of magmatic differentiation. The molten mass,

\* H. Keyserling, Der Gloggnitzer Forellenstein: Tschermak's Mineral. petrogr. Mittheilungen, xxii, 1903.

† V. de Souza Brandão, Ueber einen portugiesischen Alkaligranulit. Centralblatt für Mineralogie, Geologie und Paleontologie, 1902, p. 50.

‡ Dr. Teall and Fleet have found, last summer, in Wales, a riebeckite gneiss which in mineralogical and petrographical characters seems a granite gneiss.

§ A. Lacroix, Mineralogie de la France, i, p. 697.

¶ With the blue amphibole described by W. Cross, C. Palache has identified another blue amphibole, *crossite*, from an albite schist of Berkeley, Bul. of Geol. Depart. Calif. Univ., i, 1894. I may observe, however, following the comment of Lane and my own determinations, that this cannot be done; the crossite of Berkeley is a blue amphibole (glaucophane) which has the plane of the optic axes perpendicular to (010),  $b:c=16^\circ$ . But I have found the amphibole of Cross in a syenite from Spanish Peak, Cal., and it looks like crocidolite.

¶ S. Franchi, Prof. Louderback, etc., have found crocidolite quartzite in the area of glaucophane schists which are very similar to the riebeckite schists described by Lacroix.

isolated perhaps in an anticline or in a laccolith, is maintained for a long time as a mother liquor in a state of hydrothermal fusion in which there swim crystals already formed, or in process of formation. On account of the impermeability to vapor of the beds of shale, quartzite, etc., between which it has been introduced, the mineralizers cannot escape, they continue to act on the magma and to be gradually assimilated. The presence of fluor spar, zircon, titanite, and sulphides as constituents of the riebeckite rocks, the occurrence of pneumatogeneous and polygeneous inclusions and of schlieren with characteristic minerals confirm this view.

The chief factors in the formation of riebeckite rocks are the pressure and definite mineralizers; with the variation of these two factors and of the composition of the magma, the products of crystallization are also changed. Only under high pressure due to tectonic movements and to the persistent retention of mineralizing vapors, and with a large quantity of the latter present, could riebeckite be formed; if one of these factors varied, especially the pressure, ægirite would then occur in addition to riebeckite. Of course the pressure, the mineralizers and the composition of the magma usually differ from one point to another, as may be seen from the quantitative and qualitative variation of the mineral elements of the rocks. Especially had the assimilation of inclusions of neighboring rocks provoked such variations of chemical and physical conditions, that riebeckite could no longer be formed.

In addition to the chemical, a mechanical action was present; new upwellings of fluid magma and of mineralizers cause streams and vortices in the consolidating molten mass. These influence the crystallization and aid in the formation of schlieren; in the more quiet parts a pegmatitic or a granular structure is produced; there in the streams and more agitated areas a fluidal or a protoclastic structure originates; the rapid sinking of the temperature, the loss of mineralizing vapors, or lowering of pressure in other parts, determines a porphyritic structure with the two periods of consolidation more or less well pronounced of the mineral constituents.\*

Riebeckite forms only in the relatively most acid magmas, and especially under the influence of mineralizers: its composition, content of fluorine, long period of crystallization from the beginning up to the end of and even after the consolida-

\* In respect to the conception of the rôle of the mineralizers and inclusions, their influence at the time of consolidation of the magma, the forming of schlieren and of the structure, I incline toward the views of the French petrologists. None the less, in the ideas of Prof. E. Weinschenk I have found many points à propos to these views; the short and clear chapters on these questions in his book, *Gesteinskunde I*, 1902, excite my heartiest admiration.

tion of the magmas; its occurrence in cavities and its paragenesis with zircon, pyrochlore, fluor spar, sulphides, etc.; its presence as large crystals in pegmatites in immediate relation with veins of fluor spar or cryolite, and its absence in non-eruptive rocks, are many facts which support the view as to its origin presented in this paper.

The mineralizers which aid to produce it are not rich in water and sulphur vapors, but are characterized by an abundance of Zr, which has played a part in riebeckite granite similar to that of Sn in cassiterite granites. Zircon also forms throughout the whole period of consolidation. One can correlate: tourmaline—Sn; riebeckite—Zr and katoforite (or another soda amphibole)—Ti.

The magma has been fairly rich in  $Al_2O_3$ ,  $Na_2O$ , and  $K_2O$ , but a large quantity of soda and iron have been brought in by mineralizers and the genesis of riebeckite facilitated. The occurrence of masses and small areas of hæmatite and limonite, around or across the inclusions and schlieren, does not come from secondary alteration, but from areas which at the moment of consolidation were still more or less impregnated with iron compounds and water vapors.

Doubtless new upwellings of magma and of mineralizers have caused some transformations in the minerals already formed in the riebeckite and ægirite, but needles and fibers of crocidolite could be formed in eruptive rocks, as well as in metamorphic schists, as a phenomenon of piezocrystallization, which is quite in accord with the process which I have here tried to sketch.

ART. XIX.—*Purpurite, a new Mineral*;\* by L. C. GRATON and W. T. SCHALLER.*Introduction.*

IN the central portion of the Carolinas there occurs a belt of metamorphic rocks penetrated by narrow dikes of pegmatite, many of which contain lithium minerals. There can be little question but that the dikes of pegmatite represent the final product of a parent magma which has crystallized as granite and appears almost continuously along the extent of this belt.

Attention was first directed to these pegmatites by the discovery of cassiterite in them. In the autumn of 1904, one of the writers made an examination of these tin deposits for the U. S. Geological Survey. During the course of this study, Mr. J. L. Daniels, superintendent of the Faires tin mine at Kings Mountain, Gaston County, N. C., called attention to a purplish material encountered within a few feet of the surface in the workings of that mine. Thanks are due to Mr. Daniels, who kindly supplied much of the material obtained. Preliminary examination failed to identify the material with any known mineral, although its properties seemed to be those of a definite crystalline compound. Chemical analysis shows that the material is a new mineral, being a hydrous manganic ferric phosphate—the only manganic phosphate known.

The most striking feature of this mineral is its purple or dark reddish color, and for this reason it has been named *purpurite*, from the Latin *purpura*, purple or dark red.

Since the discovery of this mineral in North Carolina, the same mineral has been noticed on some specimens from San Diego County, California. These had been collected by one of the writers, and through the courtesy of Mr. F. M. Sickler, of Pala, several more specimens from this locality have been obtained. They are from one of the lithium-bearing pegmatite dikes on Hiriart Hill, Pala, San Diego County. The mineral occurs with triphylite, and possesses the same purple color as the North Carolina specimens. Under the microscope, the appearance and properties of the mineral from the two localities are identical. There is, however, not enough of the California material for chemical examination.

*Occurrence and Physical Properties*; by L. C. GRATON.

The mineral purpurite is found in small irregular masses in the tin-bearing pegmatite dikes, and in the near-by schist at the Faires mine. In most cases it occurs in narrow lenses or

\* Published by permission of the Director of the U. S. Geological Survey.

veinlets, and appears to have been deposited from solution in cavities. Occasionally, however, it is found in the midst of the pegmatite as if it were an original mineral.

The question of the origin of purpurite is one of interest. Pegmatite dikes believed to be closely related to the tin-bearing dikes carry the rare-earth phosphate, monazite. Among the primary minerals of the tin-bearing pegmatites are cassiterite, tourmaline, apatite, spodumene, lepidolite, and a yellowish brown, lithia-bearing phosphate which is doubtless lithiophilite. The last two minerals have been found only in small quantities. Partially decomposed specimens of this pegmatite frequently show much manganese dioxide as thin mammillary coating on the other minerals. Ilmenite is often included in crystals of cassiterite. It is evident, therefore, that the elements manganese and iron (as monoxides), lithium, and phosphorus (as phosphate) were primary components of the pegmatite magma.

The mineral presumed to be lithiophilite is always surrounded by a coating of black, secondary material. In one case, a narrow zone of purpurite was found between the lithiophilite and the black mineral. It is believed that this single occurrence furnishes the explanation of the origin of purpurite. A lithia-manganous-ferrous phosphate, probably lithiophilite, was attacked by oxidizing solutions. The lithia was almost wholly carried away, while of the remaining elements, iron and manganese were oxidized to the state of sesquioxides and were recrystallized with the phosphoric acid and water to form purpurite. The trace of lithium which this mineral contains is a remnant of that from the lithiophilite. In some cases the recrystallization took place without transportation of the materials, forming pseudomorphous replacements, but in general the materials were carried in solution to cavities and there deposited.

Purpurite is probably orthorhombic, but no specimens have been found which show crystal outline. A cleavage which is probably pinacoidal is of rather perfect development, but the cleavage surfaces are often curved as if the orientation of adjoining grains were not exactly the same. A second cleavage, presumably at right angles, is considerably less distinct. The mineral has an uneven fracture and is rather brittle. It is scratched without difficulty by the knife, but on the other hand just scratches fluorite, and hence has a hardness of 4-4.5. Mr. Schaller determined the specific gravity as approximately 3.15. In color the mineral is a rich deep red or reddish purple, sometimes with a slight bronzy iridescence, and not uncommonly darker on the cleavage planes. The powder and the streak have a decided purple or deep rose color. The mineral has a peculiar satiny luster or sheen, more noticeable on fracture surfaces than on cleavage planes.

Although transparent in very thin pieces, the ordinary thin section allows the passage of very little light through purpurite. The colors in transmitted light are very beautiful. Pleochroism is noticeable. Parallel to the cleavage the color is a deep scarlet, inclining to rose-red, while across the cleavage the absorption is greater and the color becomes a beautiful purple. This absorption, it will be noticed, is similar to that of tourmaline and a few other minerals, in which the greatest absorption is at right angles to the direction of cleavage or elongation. Extinction is generally parallel; an inclination up to three or four degrees, which has been observed in a few instances, has probably been due to the orientation of the sections examined. It may be, however, that the mineral is monoclinic, with a very small extinction angle. Sections which were transparent were not of sufficient size to give an interference figure. No sections showing the intersecting cleavages were seen, and in all the sections examined the traces of the cleavages are parallel to the direction of greater elasticity of the section; so if the mineral is biaxial, the intersection of the cleavages is parallel to  $a$ . This is also the direction of least absorption. The refractive index is somewhat greater than that of Canada balsam and probably lies between 1.60 and 1.65. The difference of the indices or the double refraction is high, and although it could not be measured at all accurately, is probably not much below .060. One effect of this high double refraction on the very thin sections examined is that under crossed nicols the mineral appears to transmit as much and as brilliant light as without polarization. The red interference colors are very striking.

The purple mineral is always covered or surrounded by a greater or less thickness of a black or brownish black material of pitchy luster and uneven or sub-conchoidal fracture. This material, which is soluble in hydrochloric acid, has been found by Mr. Schaller to contain iron, manganese, phosphoric acid, and water. Under a lens the black material can be seen to enroach upon the purpurite, eating in along the cleavage planes and gradually replacing the purple mineral. It is undoubtedly a decomposition product of purpurite and is certainly the same as that which surrounds the supposed lithiophilite. Viewed with the aid of the microscope it appears to be a definite mineral, having an imperfect cleavage, and a brownish yellow color in transmitted light. Extinction is nearly or quite parallel to the cleavage, and the trace of the cleavage is the direction of least refractive index of the sections examined. Pleochroism is distinct and, as in the case with purpurite, absorption is greatest across the cleavage. The index of refraction is greater than that of Canada balsam, and the double refraction



tion is probably rather high. It is hoped that sufficient of this material for analysis will soon be obtained.

The occurrence of purpurite in material collected from California by Mr. Schaller throws additional light on the origin and association of this mineral. It occurs with a black material which appears to be identical with that described above, and both are undoubtedly decomposition products of the accompanying triphylite, the iron-rich member of the lithia-manganous-ferrous phosphate series, of which lithiophilite is the manganese-rich end.

The small number and rarity of minerals containing manganic oxide,  $Mn_2O_3$ , may be due to the relative instability of that base in comparison with manganese dioxide.

*Chemical Composition*; WALDEMAR T. SCHALLER.

About a gram of pure material was separated by Mr. Graton. This was divided into several portions, using about a fifth of a gram for each determination. The most interesting part of the analysis was to determine the state of oxidation of the manganese. When the mineral is treated with hydrochloric acid, chlorine is readily given off. The manganese present can therefore not be in the manganous state, and the absence of ferrous iron and the presence of ferric iron suggested that the manganese was present as a manganic salt. Such was found to be the case.

A fifth of a gram was dissolved in sulphuric acid with a known amount of ferrous ammonium sulphate. All precautions were observed to avoid the presence of air, the entire operation being conducted in an atmosphere of carbon dioxide. The water used had been boiled and cooled out of contact with air. Just before the iron sulphate was introduced into the flask containing the mineral, an equal quantity was removed from the stock solution and titrated with permanganate. Thus, the amount of ferrous iron introduced into the flask with the mineral was known. After the mineral had been decomposed by the sulphuric acid, the flask was cooled and the solution titrated, the amount of iron sulphate oxidized by the liberation of oxygen from the mineral being determined in this way. From these data the amount of  $Mn_2O_3$  was calculated and found to be 30.47 per cent.

A second sample was decomposed by hydrochloric acid and the chlorine evolved passed into a solution of potassium iodide. The liberated iodine was then titrated with sodium thiosulphate, the latter being standardized with pure copper. Calculating from the results obtained, the amount of  $Mn_2O_3$  was found to be 27.93 per cent. Though these results vary somewhat, yet, considering the small amount of material used

(1/5 gram) and the many operations necessary, the agreement is as close as could be expected. The average of the two results is 29.20 per cent.

A direct determination of the total manganese, weighed as anhydrous sulphate, gave as the amount of  $Mn_2O_3$  in the mineral, 29.35 per cent, which agrees almost exactly with the average of the two indirect determinations.

The remaining constituents were determined as follows: A portion of the mineral was dissolved in hydrochloric acid and a known weight of iron added (as ferric chloride). A basic acetate separation was then made, boiling the solution for fifteen minutes, which according to Bunsen will precipitate all the phosphoric acid with the iron and will not precipitate any manganese. The precipitate was dissolved in hydrochloric acid, and reprecipitated by ammonia, after the addition of some ammonium chloride. The two filtrates were united, manganese precipitated by hydrogen sulphide and finally weighed as anhydrous manganese sulphate. Calcium was then thrown out, dissolved and reprecipitated and magnesia found to be absent. The iron-phosphate precipitate was dissolved in hydrochloric acid and divided into two portions. In the one, the iron and phosphoric acid were precipitated by ammonia and weighed. This was then fused up with sodium bisulphate and tested for manganese with silver nitrate and ammonium persulphate. None was present. In the second portion, the iron was reduced by hydrogen sulphide and titrated with permanganate. Phosphoric acid was determined in the usual way and a second value obtained by the difference between the iron and the iron plus phosphoric acid. The alkalis were determined by the Lawrence Smith method. The final solution of chlorides gave a strong spectroscopic test for lithium. The water below 105° was determined directly, using a toluene bath. The total water was determined directly by heating in a glass tube according to Penfield. The water is all given off at a low temperature, that at 105° being given off very readily, and at one time. Further heating at 105° failed to remove any more. The values obtained are as follows:

		Av.	Ratio.	
$Fe_2O_3$ .....	15.89,	15.89	1.03	} 2.96
$Mn_2O_3$ .....	29.35, 30.47, 27.93	29.25	1.93	
$P_2O_5$ .....	47.64, 46.96	47.30	3.47	
$H_2O$ .....	5.26	5.26	3.04	
$CaO$ .....	1.48	1.48	.27	} .41
$Na_2O$ .....	.84	.84	.14	
$Li_2O$ .....	tr.	tr.		
Insol. ....	.52	.52		

The amount of water given off at 105° is 3.31 per cent. As all of the water is so readily given off, it is most probably present as water of crystallization.

Considering that the calcium and soda require some phosphoric acid, the ratio of  $R''O_3 : P_2O_5 : H_2O$  is approximately 3:3:3. Combining the ratio of the calcium and sodium with that of the iron and manganese, and reducing these to their hydrogen equivalent, the ratio becomes

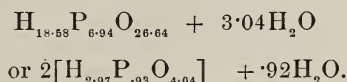

The acid is therefore  $H_3PO_4$ . The formula for the mineral then becomes  $R''O_3 \cdot P_2O_5 + H_2O$ .

It is not known in just what state of combination the calcium and sodium are. They most probably represent some slight impurity. If the manganic and ferric oxides are isomorphous in the sense that manganeous and ferrous oxides are, the ratio of  $Mn_2O_3$  to  $Fe_2O_3$  being nearly 2:1 is of no significance and the formula then should not be written  $Fe_2O_3 \cdot 2Mn_2O_3 \cdot 3P_2O_5 + 3H_2O$ , but  $(Mn''', Fe''')_2O_3 \cdot P_2O_5 + H_2O$ , the mineral purpurite being near the manganic end of an isomorphous series having as its two end members:

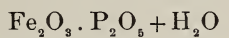

There are only a few hydrous phosphates of the normal division in which the base is trivalent, such as scorodite and strengite. All of these, however, contain more water than the mineral here described.

While no manganic phosphates were noted in the literature, there are a number of arsenates containing  $Mn_2O_3$ , with none of which, however, can purpurite be classed. Synadelphite, flinkite, arseniofleite, and perhaps hematolite, contain  $Mn_2O_3$  with  $Al_2O_3$  or  $Fe_2O_3$ , while in durangite and arseniosiderite,  $Mn_2O_3$  is reported in small amounts.

The mineral fuses easily and readily gives off water in a closed tube becoming yellowish brown. It is readily soluble to a clear solution in hydrochloric acid, while in nitric acid a black oxide of manganese separates out. The specific gravity determined on the powdered mineral by the Thoulet solution is approximately 3.15.

## SCIENTIFIC INTELLIGENCE.

## I. CHEMISTRY AND PHYSICS.

1. *Studies with the Liquid Hydrogen and Air Calorimeters.*  
 I. *Specific Heats*;\* by Sir JAMES DEWAR.—“The calorimeter employed in the following researches was similar to that described in my paper on ‘The Scientific Uses of Liquid Air,’† and in an improved form in Madame Curie’s work ‘Recherches sur les Substances Radio-Actives,’ 2d edition, p. 100. A sketch of the apparatus appears in my paper on ‘The Absorption and Thermal Evolution of Gases Occluded in Charcoal at Low Temperatures.’‡

The arrangement employed consists essentially of a large vacuum vessel capable of holding 2 or 3 liters, into which is inserted a smaller vacuum vessel of 25 to 50 c.c. capacity constituting the calorimeter, the latter being sealed on to a long narrow tube which projects from the mouth of the exterior vessel, in which it is lightly held by a loose packing of cotton wool. A little below the upper end a branch tube is taken off which conveys the volatilized gas from the calorimeter to the gas receiver. To the extremity of the projecting tube a small test-tube, to hold the portions of substance experimented on, is attached by a short piece of rather wide rubber tubing which forms naturally a movable joint that can be bent into any position. With care I have found this valve gives as good results as more elaborate means of securing the dropping of the substances into the calorimeter. A small vacuum vessel containing solid carbonic acid, liquid ethylene, liquid air, etc., into which the test-tube is placed, cools the materials to different temperatures below those of the laboratory, or alternatively it may be heated in the vapour of water or other liquids.”

The general constants for liquid gas calorimeters (here omitted) show that “an instrument in which liquid air is used has twice the sensibility of a corresponding one in which liquid ethylene is employed, whereas the substitution of liquid hydrogen for liquid air increases the delicacy of the calorimeter some seven times. It is easy to detect the transference of 1/50 of a gram-calorie in the liquid air instrument, whilst 1/300 of a gram-calorie can be similarly observed in the liquid hydrogen form of the calorimeter.”

A detailed account is given of the method of use of the instrument and also of the various sources of error. Of the experiments described the following results were obtained for carbon in the form of diamond and of graphite, and for ice.

\* Extracts from an advanced proof (received from the author) of a paper read June 8, before the Royal Society of London.

† Proc. Roy. Inst., 1894, vol. xiv, p. 398.

‡ Proc. Roy. Soc., 1904, vol. lxxiv, p. 123.

Substance.	18° to -78°.	-78° to -188°.	188° to -252°·5.
Diamond -----	0·0794	0·0190	0·0043
Graphite -----	0·1341	0·0599	0·0133
Ice -----	0·463*	0·285	0·146

“It appears from these values that between the ordinary temperature and the boiling point of hydrogen the specific heat of the diamond has been reduced to 1/19, whereas under similar conditions graphite has diminished to about 1/10. Further it will be observed that at the lowest temperatures the specific heat of graphite is about three times that of the diamond. It is also worthy of being recorded that the values of the specific heats of diamond and graphite taken between the temperatures of liquid air and boiling hydrogen are far smaller than that of any known solid substance, being even lower than that of any gas taken under constant volume.”

Another table gives the results obtained, at temperatures extending down to  $-188^{\circ}$ , for the specific heats of various substance including German-silver, brass, tellurium, sulphur, etc., to solid carbon dioxide, solid ammonia and solid sulphur dioxide. The author concludes with the remark that “an almost endless field of research in the determination of specific heats is now opened, in which the use of liquid air and hydrogen calorimeters are certain to become ordinary laboratory instruments.”

2. *On the Thermo-electric Junction as a Means of Determining the Lowest Temperatures*; by Sir JAMES DEWAR.†—“The inconvenience of using the gas thermometer at very low temperatures and the failure of platinum and other metal-resistance thermometers within  $30^{\circ}$  or  $40^{\circ}$  of the absolute zero, led me some years ago to consider the experimental behavior of the thermo-electric junction at the lowest temperatures. My special object at the time the experiments were made was to have a further confirmation of the melting point of hydrogen, and also of the lowest temperature reached on exhausting solid hydrogen, other than that I had found by means of the hydrogen gas thermometer.‡ The results have remained unpublished, because my intention has always been to extend them to other thermo-electric combinations. Not having been able to accomplish this project, they are now abstracted as affording useful information in this field of investigation, and as furnishing a general confirmation of my previous investigations.

A German-silver platinum couple was selected as likely to give the most uniform results at low temperatures, although subsequent experiments have led to the conclusion that it would have been better to have replaced the platinum by gold. As regards resistance thermometers, I have shown that gold is more reliable

\* This from  $-18^{\circ}$  to  $-78^{\circ}$ .

† Extracts from an advance proof (received from the author) of a paper read June 8 before the Royal Society of London.

‡ The Boiling Point of Liquid Hydrogen, determined by Hydrogen and Helium Gas Thermometers, Proc. Roy. Soc., vol. lxxviii, 1901.

than platinum at temperatures near the boiling point of hydrogen.\* The difficulties of the investigation were considerable: it had to be carried out at the time in the neighborhood of the machinery producing the liquefied gases required in the investigation, namely, oxygen, nitrogen, and hydrogen, so that the zero of the delicate galvanometer employed did not remain quite constant. To remedy this I inserted a rocking make-and-break in order to get the readings of each observation at both ends of the scale. In the process of removing one difficulty another presented itself, through the development of small but appreciable thermo-electric currents in the rocker. Precautions had to be taken against these and at all other metal junctions against similar small thermo-electric currents, and it was even found necessary to have a correction on account of the resistance box, inserted in the circuit to bring large readings within the limits of the scale. The galvanometer and resistance box were inserted in the German-silver branch of the couple, the points of junction of the copper leads with the German silver ends of the couple being insulated and placed close together within a vacuum test-tube packed with cotton wool to ensure equality of temperature.

Preliminary experiments showed that the junctions altered after having been subjected to the temperature of liquid hydrogen. However, on re-soldering the junctions with hard silver solder instead of soft solder, the thermo-couple accurately repeated observations at the temperature of liquid oxygen, after having passed through a liquid hydrogen bath. From this it appears that all such couples before calibration ought to be cooled suddenly in liquid air and then rapidly heated to the ordinary temperature, a similar operation being repeated with liquid hydrogen. If the couples return to their original state after such abrupt changes of temperature, then they are in a fit state for calibration.

Three series of observations were made to determine whether the resistance of the junctions varied to a noticeable extent with the temperature, namely, at the freezing point of water, at the boiling point of oxygen, and at the boiling point of hydrogen. Six very concurrent observations with varying resistances in the resistance box were made between  $0^{\circ}\text{C}$ . and  $15^{\circ}\text{C}$ . These were reduced by the method of least squares, and gave for the resistance of the circuit 3·500 ohms. Five similar results between the melting point of nitrogen and the boiling point of oxygen gave, by least squares, 3·293 ohms. Only two observations were taken in liquid hydrogen, which are therefore not entitled to the same weight as those already given, but the resistance appeared again about 3·3 ohms. As the variation of the resistance of the circuit was so slight, an attempt was made to reduce the results on the assumption of constancy, but this was not satisfactory. However, on treating the variation of the resistance of the circuit as linear with the temperature, the data came into better agreement.

\* Bakerian Lecture, "The Nadir of Temperature and Allied Problems," Proc. Roy. Soc., vol. lxviii, 1901.

The following table contains the details of the observations made with the silver soldered German-silver platinum couple, the recorded readings of the galvanometer being the means of several observed readings, corrected when necessary for resistance introduced into the circuit:—

No. of expt.	Substances used for difference of temperature.	Corresponding absolute temperatures.	Mean absolute temperature.	Mean galvanometer reading.	$dE/dt$ .
1	Water of 15° and ice	280°, 273°	280½°	463·2	30·88
2	Boiling carbonic acid and ethylene.....	195, 170	182½	693·5	27·74
3	Boiling ethylene at 10 <sup>mm</sup> and oxygen..	123½, 90½	107	724·0	21·94
4	Boiling oxygen and nitrogen.....	90½, 77½	84	279·0	21·46
5	Boiling nitrogen and melting nitrogen..	77½, 62½	70	320·7	21·38
6	Boiling hydrogen and melting nitrogen..	62½, 20½	41½	623·5	14·84
7	Boiling hydrogen and melting hydrogen..	20½, ?	?	51·0	?
8	Boiling hydrogen—solid hydrogen about 20 <sup>mm</sup> .....	20½, ?	?	64·0	?

where  $dE/dt$  is the quotient of the mean galvanometer reading by the difference of the temperatures in the third column.

On plotting the first six of these results the 1st, 2d, and 6th and means of the other three, viz.,  $dE/dt = 21·59$  at  $t = 87°$ , lie nearly on a continuous curve. The continuity of the curve, without any approach to abrupt change of form, even in the region of liquid hydrogen, shows that a silver-soldered German-silver platinum couple is an efficient instrument for the determination of the lowest temperatures hitherto reached."

A detailed discussion of the four sets of observations, Nos. 3, 4, 5, 6, follows, with the results given below; those from Nos. 5 and 6 are probably the most accurate.

"The general results with the German-silver platinum junction may be summarized in the following table, the typical equation being  $dE/dt = m + nT$ .

Source of constants.	$m$	$n$	Melting point of hydrogen.	Solid hydrogen exhausted.
(3) and (6) .....	12·52	0·108	16°·4	15°·27
(4) and (6) .....	11·49	0·158	15°·9	14°·7
(5) and (6) .....	9·931	0·231	15°·0	13°·5
Graphically.....	10·2	0·167	15°·5	14°·15
Mean.....	-----	-----	15°·7	14°·4

It is added that in the paper on liquid hydrogen, already referred to, the temperatures obtained by the hydrogen gas thermometer for the boiling point of hydrogen and the solid under exhaustion were  $19^{\circ}.63$  and  $14^{\circ}.34$  respectively. Finally it is concluded that, "at as low a temperature as  $6^{\circ}$  absolute, the sensibility of this couple is still half what it was at  $20\frac{1}{2}^{\circ}$  absolute, and therefore that, unless some absolute breakdown in the law connecting electromotive force and temperature below  $14^{\circ}$  takes place, it must continue to be an excellent thermometer, and will record temperature with considerable accuracy down to the boiling point of helium, which is about  $5^{\circ}$  or  $6^{\circ}$  degrees absolute."

## II. GEOLOGY.

1. *Geology of the Vicinity of Little Falls, Herkimer County*; by H. P. CUSHING. Bull. 77, New York State Mus., 1905, pp. 95, pls. 1-15, and topographic and geologic maps.—Mr. Cushing here gives an account of the geology of one of the most interesting regions in New York. In this presentation he does not limit himself to the area of his map, but notes as well the general geology of the Adirondack region, thus setting forth in a philosophical manner the historical events which have taken place in northeastern New York.

The author states that the Adirondacks formed a low-lying land when the Potsdam sea encroached upon it. "It is possible that a small area may have persisted above sea level throughout [to the close of Utica time], though it is not likely, and in any case it was very small." The southern part of the Adirondack mass was the last to pass beneath the sea. The Potsdam is thickest on the northeast border, thinning out both westward and southward; it is not known on the south side about Little Falls. Upon the Potsdam along the eastern side was laid the Beekmantown limestone, but, according to the reviewer, it is questionable whether the so-called Beekmantown of the southern exposure is of the same age. These southern dolomites are 450 feet thick at Little Falls, but diminish to "nearly or quite zero at the northern limit of the sheet." Upon this formation in both areas follow the limestones of the Mohawkian series and then the Utica shales. At the top of the Utica "the present Adirondack region was either wholly submerged or else so nearly so that only a few small islands were left protruding above the water." This is not the generally accepted view and the occurrence of Potsdam within the Adirondack mass will have to be explained as depressed fault-blocks.

"Following the deposition of the Utica formation came a movement of disturbance and uplift of the region on the northeast and east. This apparently raised the present Champlain valley and northern Adirondack region above sea level, while the southern portion was not affected and remained submerged. . . .

"Quite possibly the first faulting of the region took place at the close of the Lower Silurian coincidentally with the Taconic



disturbance. . . . The Little Falls fault has a throw of nearly or quite 800 feet at Little Falls."

One of the most interesting problems suggested by this bulletin is—What is the relation of the so-called Beekmantown formation of this Little Falls region to the true Beekmantown of the Champlain valley? The author shows how these dolomites overlap and disappear northward over the Adirondack mass. "Nor does the basal bed at Little Falls appear to represent the real base of the formation, deep well records to the west seeming to indicate an increased thickness in that direction." The sequence of the Upper Cambrian and the succeeding dolomites of the Great Interior Sea apparently denote continuous deposition and show that the dolomites along the south side of the Adirondacks are those of a shallow sea, with a sparing fauna. Their age is probably closely connected with the Cambrian and is doubtless older than the Beekmantown of the Lake Champlain area. The faunas of the two areas are widely different, that of the Lake Champlain district being a normal marine one abounding in large cephalopods and gastropods, hardly any of which are found in the Mohawk valley. Again, the sequence varies greatly in the two areas, as in the Lake Champlain region the Beekmantown is followed by the Chazy, while in the Mohawk valley the Lowville reposes on the so-called Beekmantown dolomites. On the northeast side of the Adirondacks the Paleozoic section is at least 3000 feet thicker than in the Mohawk valley.

c. s.

2. *Geology of the Watkins and Elmira Quadrangles, accompanied by a geologic map*; by JOHN M. CLARKE and D. DANA LUTHER. Bull. 81, New York State Mus., 1905, pp. 1-29, with a map and a section.—This Bulletin describes in detail the Upper Devonian strata of these quadrangles, with considerable notation of the occurrence of the faunules of the following horizons :

		Feet.	
Neodevonian	Chatauquan	Chemung sandstone and shale	800
		Prattsburg shale	250
		High Point sandstone	85
		West Hill flags and shale	315
		Grimes sandstone	75
		Hatch shale and flags	440
	Senecan	Rhinestreet black shale	1
		Parrish limestone, in the Cashagua shale	207
		West River shale	35
		Genundewa limestone	1
		Genesee shale	6+

Much detail is presented in regard to the distribution of the characteristic Naples or black shale fauna and its interlocking but rarely commingling with the eastern or Ithaca fauna. The latter is a direct outgrowth of the Hamilton, as may be seen from

Bulletin 82, reviewed below. The eastern or Ithaca fauna appears for the first time, but sparingly, in the lower portion of the Cashaqua shale, as far west as the region about Watkins Glen, and there are several alternations of this fauna with the Naples in the higher Hatch shale. The Iowa Lime creek fauna of 32 species has its only occurrence near the middle of the High Point sandstone, while *Spirifer disjunctus*, apparently a migrant also from the west or southwest, is seen for the first time in the Genesee valley, in the lower portion of the Prattsburg shale. "The horizon of *Spirifer disjunctus* follows close on the change from the Naples fauna in western New York at a high altitude above the base of the Portage formation. In central New York there is no such change, but the gradation from the Ithaca fauna out of the Hamilton fauna upward into the association which carries species elsewhere concurrent with *Sp. disjunctus* is very easy, and it is extremely difficult to draw a division plane anywhere except on the basis of refined distinctions into successive faunules. *Spirifer disjunctus* in this eastern region did not appear till this period of 'Chemung' deposition was well nigh over." c. s.

3. *Geologic Map of the Tully Quadrangle*; by JOHN M. CLARKE and D. DANA LUTHER. Bull. 82, New York State Mus., 1905, pp. 35-70, with map.—This Bulletin describes the following formations:—

						Feet.
Neodevonian	Senecan	}	Ithaca	Ithaca flags and sandstones	450	
			Portage	Sherburne flags	210	
			Genesee	Genesee shale	75	
			Tully	Tully limestone	23	
Mesodevonian	{	Eirian	Hamilton	Moscow shale	180	
				Ludlowville shale	350	
			Marcellus	Skaneateles shale	335	
				Cardiff shale	175	
				Marcellus shale	100	
Paleodevonian	{	Ulsterian	Onondaga	Onondaga limestone	65	
			Oriskany	Oriskany quartzite	6	
		Helderbergian	Helderberg	New Scotland limestone and		
				Coeymans limestone	40	
Silurian	Cayugan	}	Manlius	Manlius limestone	74	
				Rondout dolomite	40	
			Salina	Cobleskill dolomite	6	
				Bertie dolomite	15	
		Camillus shale	40			

The evidence regarding the presence of the New Scotland in this area is not convincing. As the present writer did not find this formation to the east, about Litchfield, it appears to him more probable that the New Scotland does not occur in the Tully quadrangle.

Dr. Clark adds a chapter on the "Ithaca fauna of Central New York," and lists 199 species collected by Mr. Luther from 80 stations. Of these forms, not less than 106 occur beneath the top of the Tully, abundantly confirming the statement of the author that "the fauna in point of number is prevailingly affiliated to that of the Hamilton."

The leading Hamilton species commonly found at these stations are the following: *Phacops rana*, *Pleurotomaria sulcomarginata*, *Actinopteria boydi*, *Glyptodesma erectum*, *Modiomorpha concentrica*, *M. mytiloides*, *Grammysia bisulcata*, *Cimitaria recurva*, *Microdon bellistriatus*, *Nuculites oblongatus*, *Nucula bellistriata*, *Palaeoneilo emarginata*, *Paracyclas lirata*, *Rhipidomella vanuxemi*, *Spirifer mucronatus*, *Cyrtina hamiltonensis*, *Camarotcechia congregata* and *Tropidoleptus carinatus*. c. s.

4. *Contribution to the Paleontology of the Martinez group*; by CHARLES E. WEAVER. Univ. California Pub., Bull. Dept. Geol., pp. 101-123, pls. 12, 13, date of printing not given.—This Eocene fauna consists of 67 species. Of these 18 are new and with 3 others are described and illustrated.

"The Martinez represents a distinct division of time in the geological history of California. It contains a fauna distinct from both the Chico and the Tejon. On the average it is composed of about two thousand feet of thick-bedded sandstones, together with some shales, thin-bedded sandstones and conglomerates. . . . Its position in the geological scale seems to correspond most closely to a portion or all of the lower quarter of the Eocene."

"There was probably no direct faunal connection between India and the Western Coast of North America in Martinez times. . . . The evidence seems also to point to the fact that during this period the Martinez seas were isolated from the regions of the southeastern United States." c. s.

5. *Faune cambrienne du Haut-Alemtejo (Portugal)*; par J. F. NERY DELGADO. Comm. Serv. Geol. du Portugal, v, 1904, pp. 307-374, pls. 1-6.—This work describes a very interesting Lower Cambrian fauna. It is especially noteworthy because of an abundance of bivalve shells of which 9 species are described, whereas in North America the *Olenellus* fauna is known to have but 2 species and but one of these is common.

The author regards this fauna as probably Lower Cambrian; from a survey of the genera adopted, however, his readers would be perplexed to know to what age these beds should be referred, were it not for the good photographic plates illustrating the species. *Paradoxides choffati* is clearly an *Olenellus*. The several species (9) of *Hicksia* are very suggestive of Lower Cambrian *Solenopleura* and especially of a form found at York, Penn. Of *Microdiscus*, the author describes 5, but *M. caudatus*, *M. subcaudatus*, and *M. wenceslasi* must be placed under a new genus, because they have dorsal eyes and a caudal spine. As *M. souzai* and *M. woodwardi* have eyes, they, too, should be referred to

another genus. It may be best to erect a new genus with *M. woodwardi* as the genoholotype, and a new subgenus with *M. caudatus* as the type species.

The Pelecypoda, as far as their generic reference is concerned, are very inadequately treated. One is referred to *Posidonomya*?, 2 to *Modiolopsis*, 1 to *Synek*?, 3 to *Davidia*, and 1 to *Ctenodonta*. While these names may indicate the types of pelecypods represented, yet it is safe to state that a careful study will show that all belong to other, probably new genera. The species are small and thin-shelled. In a conversation with Professor Verrill he concluded that all these Lower Cambrian bivalves were probably free-swimming forms.

The brachiopods are also very unsatisfactorily referred generically, and the illustrations are inadequate for more accurate determination.

This fauna of Portugal is certainly of Lower Cambrian age, and while it has relationship with that of York, Penn., yet in its trilobites and especially in its pelecypods it has a faunal facies entirely distinct from any American Lower Cambrian fauna.

c. s.

6. *Paraphorhynchus*, a new genus of *Kinderhook Brachiopoda*; by STUART WELLER. Trans. Acad. Sci. St. Louis, xv, 1905, pp. 259-264, pl. 1.—This rhynchonelloid form has the interior generic characters of *Camarotœchia*, with the exterior of *Pugnax*, to which is added a finely striated surface of the shell. The genoholotype is *Paraphorhynchus elongatum*, sp. nov. Other species are *P. transversum*, sp. nov., *Rhynchonella striatocostata* Meek and Worthen, *R. medialis* Simpson, and *R. striata* Simpson.

c. s.

7. *Sympterura Minveri*, n. g. et sp.: a Devonian Ophiurid from Cornwall; by F. A. BATHER. Geol. Mag., II, 1905, pp. 161-169, pl. 6.—This important paper describes in detail the skeleton of this brittle-star. The description is followed by a learned interpretation of the parts of the organism and their relation to other ophiurid structures.

c. s.

8. *The ancestral origin of the North American Unionidæ, or fresh-water Mussels*; by CHARLES A. WHITE. Smithsonian Misc. Coll. (Quarterly Issue), June, 1905, pp. 75-88, pls. 26-31.—After a long silence in Paleontology, Dr. White returns to a group of shells on which he has often worked.

The oldest American Unionidæ occur in the Triassic. They "are all of simple form, and none of them exhibits distinctive prototypal relationship to the living Mississippi River fauna." Of Jurassic species, but seven are known and none of these appears to be directly related to the living shells. Toward the close of the Cretaceous, "the family received an extraordinary development" and increased its diversity. In the Laramie strata are found the greatest number of species of *Unio* having prototypal features connecting them with existing species in so marked a manner "that Professor Whitfield has given names to

the fossil forms [three] which are only modifications of the names of the living forms which they so closely resemble." In the Tertiary all connecting forms are absent, but the author explains that the Cenozoic species thus far found are plain types such as are now obtained only in still waters or lakes. "The more diverse and ornamental forms of living *Uniones* occupy fluviatile, or other running or moving waters. None of the deposits containing the Tertiary *Uniones* referred to gives any inherent evidence of having been formed in fluviatile or estuarine waters."

"Fresh-water gill-bearing faunas have as certainly descended genetically through successive geological ages to the present time as have marine faunas. . . . There has never been any intermission of such continuity because the fresh-water supply has never failed, and because, as a rule, rivers have been among the most persistent of the earth's surface features." c. s.

9. *The Thalattosauria, a group of marine reptiles from the Triassic of California*; by JOHN C. MERRIAM. Mem. California Acad. Sci., V, 1905, pp. 1-52, pls. 1-8.—During the past three years the Geological Department of the University of California has been collecting the remains of the marine reptiles from the Upper Triassic of Shasta county. From the fact that both are black, the material is very difficult to clear from the matrix, the latter being a shaly limestone.

This memoir describes in detail the skeletal structure of the Thalattosauridæ, comprising the genera *Thalattosaurus* (*T. alexandree*, *T. shastensis* sp. nov., *T. perrini* sp. nov.) and *Nectosaurus* gen. nov. (*N. halius* sp. nov.). The pen and ink illustrations are good.

"The Thalattosaurs represent an early adaptation to marine conditions of that division of the Reptilia which has persisted in measurably primitive form in the Rhynchocephalia. During the early history of that group it gave rise to a numerous company of forms taking quite divergent paths in their evolution. Of the older orders only the Proganosauria were aquatic. They appear, however, to have been limited to fresh water. The Thalattosaurs are evidently the marine representatives of this great rhynchocephalian or diaptosaurian group." c. s.

10. *The Geology of Littleton, New Hampshire*; by C. H. HITCHCOCK. Pp. 38, 2 plates and map. Reprinted from History of Littleton, 1905.—This paper brings together all that is known in regard to the geology about Littleton, including the recently published article by Hitchcock (Bulletin Geol. Soc. America). The strata present are referred to the Quaternary, Helderberg, Silurian, Lower Silurian or Cambrian, and eruptives. In an appendix, Mr. Avery E. Lambert describes a new trilobite, *Dalmanites lunatus*, with notes on other fossils from the Littleton area. c. s.

11. *Vorschule der Geologie*; von JOHANNES WALTHER. Pp. 144, and 98 original text figures. Jena, 1905.—This very interestingly written, simply stated, and well printed little book on elementary geology is intended for beginners in geology. They

are led to observe nature for themselves and are shown how to determine the stratigraphic sequence in the profiles leading up to map making. Comparative stratigraphy and historical geology are not here considered.

There are 18 chapters, as follows: 1. Introduction; 2. Geological exposures; 3. Weathering (physical, chemical, and organic); 4. Results of weathering; 5. Kinds of rocks; 6. Rock-clefts or joints; 7. Subterranean waters and springs; 8. Infiltration of joints and caves; 9. Flowing waters; 10. Standing waters; 11. Sea-shore; 12. Mountains and hills; 13. Deformation and earthquakes; 14. Plutonic appearances; 15. Volcanic activity; 16. Stratigraphic sequence; 17. Maps; 18. Chronological sequence.

The book is distinguished for two things: The "Aufgaben" and the many clear and well-drawn diagrams of geological structures. At the end of each chapter, under "Aufgaben," the student is directed how and where to look for the things described. There are 110 of these lessons. c. s.

12. *Die Moore der Schweiz mit Berücksichtigung der gesammten Moorfrage*; von Dr. J. FRÜH und Dr. C. SCHRÖTER. Herausgegeben von der geologischen Kommission der Schweiz-Naturforschenden Gesellschaft. Preisschrift der Stiftung Schnyder von Wartensee. Pp. 751, 5 plates, figures in text. Bern, 1904.—This voluminous quarto report comprises a most elaborate treatment of swamps and peat-bogs, particularly in regard to those of Switzerland. Dr. Früh, professor of geography, and Dr. Schröter, professor of botany, at the Polytechnikum at Zurich, have combined in a most thorough manner the knowledge concerning these deposits from the point of view of geography, climatology, and botany. The first part of the work deals with vegetal deposits now making in northwestern and central Europe and in a general way with those of other districts, with reference to the classification of the deposits and an analysis of all the conditions which affect the growth of the plants and the accumulation of vegetal deposits. The second part of the work is devoted to a detailed description of local deposits within the confines of Switzerland. Throughout this work the botanist and the geographer have labored together to present precisely and technically the varied conditions which are displayed in the various plant colonies encountered within their field of study. Over 6,000 microscopic preparations were examined in the study of the stratigraphy of peat-beds. Helpful schematic tables arranged in the form of geological cross-sections of the types of swamp accumulations present a summary of the chapters of description, in which climate, altitude, position in relation to sunshine, slope, drainage, and accidental factors, are equally faithfully portrayed with encyclopedic fulness. A useful discussion of the world distribution of vegetal accumulations of the present day is accompanied by a mercator's chart showing the grouping of the broader divisions of vegetal deposits. There is also a chapter on the flora of the interglacial deposits. The authors, notably Früh, do not find that bacteria are effective producers of the change from

ordinary cellulose to the peaty state of vegetable matter. As a contribution to the æcology of plants the work is of exceptional interest. To the student of Pleistocene and Post-glacial deposits it seems clear that a like investigation of the vegetal deposits of America, for which there is abundant material, would prove equally valuable. There is an appended bibliography of 280 or more papers, and a topographic map of Switzerland on the scale of 1 : 530,000 showing by colors the distribution of swamps.

J. B. W.

13. *A Study of Recent Earthquakes*; by CHARLES DAVISON, Sc.D., F.G.S. Pp. xii + 355, with 80 illustrations. London, 1905 (Contemporary Science Series. The Walter Scott Publishing Co.).—The scope and object of this work are well stated in the opening paragraph of the preface, here quoted :

“The present volume differs from a text-book of seismology in giving brief, though detailed, accounts of individual earthquakes rather than a discussion of the phenomena and distribution of earthquakes in general. At the close of his *Les Tremblements de Terre*, Professor Fouqué has devoted a few chapters to some of the principal earthquakes between 1854 and 1887; and there are also the well known chapters in Lyell’s *Principles of Geology*, dealing with earthquakes of a still earlier date. With these exceptions there is no other work covering the same ground; and he who wishes to study any particular earthquake can only do so by reading long reports or series of papers written perhaps in several different languages. The object of this volume is to save him this trouble, and to present to him the facts that seem most worthy of his attention.”

The eight earthquakes selected are those which have been most thoroughly studied, “or which are of special interest owing to the unusual character of their phenomena, or the light cast by them on the nature and origin of earthquakes in general.”

This volume is a welcome addition to recent earthquake literature, and forms what may be regarded as a valuable supplementary volume to the recent work of Dutton’s treating of earthquakes in general.

J. B.

14. *An Introduction to the Geology of Cape Colony*; by A. W. ROGERS, Director of the Geological Survey of Cape Colony. With a chapter on the fossil reptiles of the Karroo Formation by Prof. R. BROOM, M.D., BSc., of Victoria College, Stellenbosch. 463 pp., 21 plates, 22 text figures and a colored geological map. London, 1905. (Longmans, Green & Co.)—This well written and clearly printed book makes a very desirable addition to geological literature, bringing into one compact volume the geology of Cape Colony and enabling the specialist in other geological fields to gain, with a minimum of effort, a comprehensive idea of this distant part of the earth.

The Cape System is the oldest within which organic remains have been found, the middle member consisting of shales and thin sandstones 2500 feet thick containing fossils identical with or closely related to species which are found in Devonian rocks

of America and Europe. Beneath the Cape System are found a great thickness of closely folded and metamorphosed sedimentary formations largely injected with granite and embracing as many as four unconformable subdivisions.

The base of the Cape System consists of the topographically prominent Table Mountain sandstone, with a maximum thickness of 5000 feet, remarkably constant in character over the whole area of its present occurrence, probably over 90,000 square miles, pointing to its deposition over a wide shallow platform with unknown limits fronting a land which probably lay to the northward. An interesting feature is the occurrence of a thick shale-band with pebbles up to five inches in diameter occasionally flattened and striated. The pebbles are scattered irregularly through the shale and mudstone without any tendency to form beds of conglomerate. Considering all the evidence, it is concluded that the pebbles were distributed by floating ice somewhere early in Neopaleozoic times.

Following the Cape System, conformably in the south but unconformably in the northern portion of the Colony, is the Karroo System, with a maximum thickness of not less than 14,000 feet; it is rich in the remains of Permo-Carboniferous and Triassic reptiles. Its base, the Dwyka Conglomerate, a thousand feet in thickness, appears to consist in the south of iceberg deposits and in the north of true bowlder clay resting unconformably upon striated and moutonnéed surfaces with indications of ice movement from the north toward the south. Several plates from photographs illustrative of these highly interesting occurrences are given.\*

Sometime after the middle of the Karroo a period of folding set in, building the mountain structures of Cape Colony facing outwards toward the oceans. This was followed by a period of great basic intrusions and of volcanism closing the Triassic. Since that time the history of Cape Colony has been preëminently one of successive uplifts and erosion; an erosion history interrupted in early Cretaceous times by a partial subsidence and probably an increased aridity of climate, and checked occasionally in later times by an approach of the river valleys to base level.

It is to be noted that on the southeast the even coast line cuts across the folded structures for a distance of four hundred miles, and there are indications, as in a downfaulted remnant of the Cretaceous, that post-Cretaceous faulting has played an important part in this truncation of older structures and the present termination, at this place, of the continental platform. J. B.

15. *Ice Erosion Theory a Fallacy*; by H. L. FAIRCHILD. Bull. Geol. Soc. Amer., vol. xvi, pp. 13-74, pls. 12-23. Published Feb., 1905. Read Jan. 1st and Dec. 30th, 1904.—In this article the author defines glacial erosion as the power of making vast and deep excavations in the solid or live rock, resulting in

\* See also the article on this subject by E. T. Mellor in this number, pp. 107-118.



the excavation of fiords and large lake basins, a power which is questioned by many geologists and accepted by others equally, if not more, numerous; the capacity of removing loose material and of plucking away frost-loosened blocks, especially where facilitated by vertical jointing, being, on the other hand, universally conceded.

The arguments for deep erosion are discussed in detail and are considered to be inconclusive. Following this, concrete illustrations are given from several glaciated mountain ranges, showing a scouring and polishing action in valleys originating from preglacial erosion rather than a topographic transformation of the preglacial surface.

Among the important consequences from such conclusions, Fairchild considers that fiords and hanging valleys may and ordinarily do occur as the result of preglacial erosion, masked, however, by the glacial occupancy and signifying therefore certain preglacial changes in the altitude of the land. It is conceded, however, that glacial action emphasizes and makes more conspicuous hanging valleys of preglacial origin.

Following the above is a discussion of the evidence from the state of New York, with the conclusion that continental as well as Alpine glaciation is ineffective as a powerful erosive agent.

In many ways the quantitative value of ice erosion is an important problem and the writer has certainly presented ably his views upon the subject, but they would probably have met with a readier acceptance among those holding different opinions if prefaced with a less assertive and combative title. Many details of the argument, such as the significance of cross striae as indicative of weak erosive power, are still open to discussion in a manner similar to that on the subject of hanging valleys; but coming down to the essential conclusions of the problem, Professor Fairchild and many of his opponents upon this question are probably nearer together than would at first appear, the problem turning on the quantitative value of ice erosion: the one side holding that it is rapid and important, the other that it is slow and very subordinate to the aggregate effects of the previous fluvial and subaërial sculpture.

J. B.

16. *Hanging Valleys*; by I. C. RUSSELL. Bull. Geol. Soc. Amer., vol. xvi, pp. 75-90. Read Dec. 30th, 1904. Published Feb., 1905.—A number of prominent physiographers have considered hanging valleys to result as a rule from the unequal erosion of valleys by glaciers of unequal size and to represent therefore the differential erosive power of the main and tributary glaciers, the total erosive power being necessarily still greater.

Dismissing the idea of glacial action as being the sole or necessary cause, a hanging valley may be defined, as stated by Chamberlin and Salisbury, as "when the lower end of the tributary valley is distinctly above the level of its main." On this basis Russell divides hanging valleys into four species, namely, stream-formed, ocean-formed, diastrophic, and glacier-formed. Even

among the glacier-formed "there appear to be at least six sets of conditions or processes each of which may produce glaciated hanging valleys without necessitating a conspicuously great measure of differential ice erosion." Illustrations confirmatory of these conclusions are cited from Stein mountain in south-eastern Oregon and from the Sierras.

The discussions of this paper may be considered as an amplification of one phase of the general problem presented in Fairchild's paper, and tending likewise to diminish the conception of the total magnitude of ice erosion.

J. B.

17. *Glaciation of the Green Mountains*; by C. H. HITCHCOCK, LL.D., pp. 21. Montpelier, Vt. (Argus and Patriot Press, 1904.)—After a review of the literature and an examination of the data in regard to all the higher summits of New England and New York, Dr. Hitchcock concludes that all, including Mt. Katahdin, Mt. Washington and Mt. Marcy, were completely buried beneath the continental ice and that any nunataks must be sought for among the Catskills or some other highland comparatively near the ice-border just as they are in Greenland to-day.

J. B.

18. *Ice or Water*; by SIR HENRY H. HOWORTH. In three volumes. London, 1905 (Longmans, Green & Co.).—This voluminous work, each volume consisting of some five hundred pages, is by the author of a previous work of the same character entitled "The Glacial Nightmare and the Flood." He calls the present volumes "Another appeal to induction from the scholastic methods of modern geology," and reiterates and amplifies the views current in regard to the origin of the "drift or diluvium" previous to 1840.

For geologists there is no need of a review of this work as the titles of this and the previous one are sufficiently explanatory, but as the former has met with some little acceptance among those interested in geology but not specialists in the science, as is witnessed in a recent work by the Rev. N. Hutchinson, and as this is doubtless intended for the same class of readers, it may be well to say that the conclusions drawn in these volumes are essentially those held previous to 1840, thoroughly threshed out during the next twenty years and as thoroughly abandoned by all active geologists for the past thirty. A considerable part of the argument turns upon the idea that since the *causes* of the ice age are but poorly understood and there is as yet no unanimity of opinion upon that subject, therefore it is bad logic to believe in the existence of an age of ice at all.

The author has, however, read up glacial literature with considerable thoroughness, and he destroys to his satisfaction every theory of the glacialists including those which are founded upon the best accepted facts as well as those proposed upon insufficient knowledge and which have been already left by the wayside by all prominent glacialists themselves. In reading these volumes one is reminded of a criticism of Brögger dealing with a similar reversion to an earlier period of thought "Der menschliche Geist

ist wunderbar conservativ: denn Ansichten, die man schon längst als todt und begraben ansehen müsste, stehen immerfort wieder als Gespenster aus der Vergangenheit auf." J. B.

### III. MISCELLANEOUS SCIENTIFIC INTELLIGENCE.

1. *The United States National Museum*; by RICHARD RATHBUN. Report of the U. S. National Museum for 1903, pp. 177-309, with 29 plates. Washington, 1905.—This is a very readable and well illustrated account of the Government Museum buildings in Washington; the first of these is the picturesque Smithsonian building finally completed in 1855 and restored in 1865-1867 after the partial destruction by fire in January, 1865. This was followed by the National Museum, completed in 1881 under Secretary Baird. The plans for the new Museum building, the foundations of which have been recently begun, are also presented.

2. *Forestry: Tenth Annual Report of the Chief Fire Warden of Minnesota*, for the year 1904; by C. C. ANDREWS. 135 pp., with 17 plates.—The annual appropriation by the State of Minnesota in behalf of the preservation of its forests amounts to the very small sum of \$5,000. The present report shows how much can be accomplished with even this amount, and it cannot be believed that the strong plea of the Chief Fire Warden for adequate support and an enlightened policy can be disregarded; certainly the matter is one in which the State has a vital interest.

3. *Les Prix Nobel en 1902*. Stockholm, 1905.—The Swedish Academy of Sciences has recently distributed an interesting volume giving an account of the distribution of the Nobel prizes in 1902, with plates showing the medals and diplomas, also the portraits of the recipients accompanied by brief biographies. The prizes were awarded as follows, viz.: in physics, to H. A. Lorentz and Pieter Zeeman; in chemistry, Emil Fischer; in medicine, Ronald Ross; in literature, Theodor Mommsen. The volume also contains the Nobel lectures by Professors Lorentz, Zeeman, Fischer, Ross and Ducommun.

4. *Negritos of Zambales*; by WILLIAM ALLEN REED. 90 pp., 62 plates. Manila, 1904 (Ethnological Survey Publications, vol. II, Part 1).—Of the various publications which appear from time to time from Manila, not the least important are those devoted to ethnological subjects. The present paper, which forms Part I of vol. II, is devoted to an account of the interesting race of pygmy blacks, the Negritos of Zambales Province; it presents the subject very fully, with a large number of plates, reproduced from photographs.

5. *A Magnetic Survey of Japan reduced to the Epoch 1895.0 and the Sea-level*, carried out by order of the Earthquake Investigation Committee. Reported by A. TANAKADATE. 347 pp., 98 plates, Tokyo, 1904. The Journal of the College of Science, Imperial University of Tokyo, Japan, vol. xiv.—This large volume presents the results of the Magnetic Survey of Japan,

carried on, under the auspices of the Earthquake Investigation Committee, during the four summers from 1893 to 1896. The Appendix gives a complete list of the observations, reduced to 1895.0 and sea-level. A large number of plates and eleven beautifully executed maps accompany the text. Many of the maps are double, a thin rice-paper chart covering a second one on thick paper; in this way a double series of data are presented.

6. *Beiträge zur chemischen Physiologie*, herausgegeben von F. HOFMEISTER. Band VI. 1905. Braunschweig (F. Vieweg und Sohn).—The present volume, like its predecessors, contributes a large number of new data to the literature of physiological chemistry. Only a few of the 41 papers can be selected for special mention in this place. Many of them deal with the chemistry of metabolism. Thus von Bergmann and Langstein have investigated the "residual nitrogen" of the blood; Knop, the metabolism of aromatic fatty acids; Eppinger, the physiological formation of allantoin and urea; Blumenthal, the assimilation limits for common sugars after intravenous introduction; and Steinitz and Weigert, the composition of the body after improper nutrition. Dr. von Fürth has published the details of an extensive study of the oxidative decomposition of proteids. Friedmann's research on the chemical structure of adrenalin, Pollak's paper on the diversity of tryptins, and Embden's various papers on carbohydrate metabolism indicate the scope of the journal. Students of haemolysis and related topics will be interested in the papers by Pascucci upon the chemistry of the stroma of the red blood corpuscles, and one by Hausmann on the behavior of saponin in the presence of cholesterin. L. B. M.

7. *Du Laboratoire à l'Usine*; par LOUIS HOULLEVIGUE, Professeur à l'Université de Caen, 299 pp., 12mo. Paris, 1904 (Armand Colin).—This useful little book discusses in elementary form a wide range of well-selected practical topics: the part played by machines; the gas meter; the transformation and distribution of energy; the industrial Alps; electro-chemistry; lighting by incandescence; the production and use of extreme cold; molecules, ions and corpuscles. The method of presentation is adapted to the requirements of the ordinary public interested in the applications of science.

8. *Traité Complet de la Fabrication des Bières*; par MM. G. MOREAU and LUCIEN LÉVY. 674 pp., 5 plates, 173 figures in the text. Paris, 1905 (Libr. Polytechnique, Ch. Béranger Éditeur, successeur de Baudry et Cie.).—This volume, like others which have preceded it from the same publishers and belonging to this series, is a very complete and exhaustive discussion of the subject of which it treats. This is somewhat out of the range of this Journal, but attention may be called to the discussion of the botanical side of the various forms of hops and barley, also of the yeast, and of the part played by bacteria; these have more than a technical interest. The illustrations are numerous and good and the whole presentation of the technical part of the subject is very thorough.

# MERELY A REMINDER

THIS PAGE is occupied by us merely as a reminder that the only concern in America which can supply you with

SPECIMENS IN ALL DEPARTMENTS OF NATURAL HISTORY

(Except Botany and Entomology)

IS

## Ward's Natural Science Establishment

To our old friends, the leading museums, colleges, educators and private collectors of the world, we are continually offering new things, some of which will be announced at the bottom of this page, from time to time. We endeavor to always remember you with our latest circulars; if you have failed to receive these recently, a line from you will bring them by return mail.

To those who have not formerly dealt with us,—our establishment was founded in 1862, and incorporated in 1890 as a stock company with a paid-up capital of \$125,000. We occupy a frontage of 250 feet facing the University of Rochester, and are known from the Yukon to the Ganges as the largest institution in the world dealing in Natural History Specimens. For over forty years we have made it our sole business to collect, prepare and sell these, individually or in collections. Quality rather than extreme cheapness is our aim, and we have spared no expense to maintain a high standard and a standing in scientific circles. We pay no commissions, but deal direct with our customers, and sell at list prices only. We offer school collections as low as \$5 and have made one cabinet costing over \$100,000 (Field Columbian Museum, Chicago), and seventeen others ranging from \$10,000 to \$70,000. In numerous instances we have built a large public museum complete at one stroke. Our catalogues, over twenty in number, are not mere price-lists, but are valuable as reference works, and have even been used as text-books in academies and colleges. A small charge is made for these, except to our regular customers or teachers intending to purchase; a list will be sent upon request. We also issue free circulars in all departments, and shall be glad to place your address on our mailing list.

### OUR DEPARTMENTS.

*Mineralogy* (Minerals, Rocks, Crystal Models, Meteorites, etc.).  
*Geology* (Phenomenal Series, Relief Maps, Geological Models).  
*Palaeontology* (Fossils, Casts of Celebrated Fossils, Wall Charts, etc.).  
*Archaeology and Ethnology* (Specimens, Models, Casts of Monuments).  
*Invertebrates* (Shells, Echinoderms, Corals, etc.; Biological Supplies).  
*Zoology* (Mounted Skins and Skeletons, Custom Work in Taxidermy).  
*Human Anatomy* (Human Skeletons, and Anatomical Models of all kinds).

### SPECIAL ANNOUNCEMENT FOR THIS MONTH.

Send for circulars of our improved MINERAL AND ROCK TRIMMER and of PENFIELD GONIOMETERS. Also for catalogue of Palaeontological Charts and for new complete "Supplement of Naiades" (Unionidae).

Ward's Natural Science Establishment,

76-104 COLLEGE AVENUE, ROCHESTER, N. Y.

## CONTENTS.

	Page
ART. X.—Mechanical Equivalent of the Heat Vaporization of Water; by R. H. HOUGH .....	81
XI.—Phosphorescence of Zinc Sulphide through the Influence of Condensed Gases obtained by Heating Rare-Earth Minerals; by C. BASKERVILLE and L. B. LOCKHART .....	93
XII.—Action of Radium Emanations on Minerals and Gems; by C. BASKERVILLE and L. B. LOCKHART .....	95
XIII.—Behavior of Typical Hydrous Bromides when Heated in an Atmosphere of Hydrogen Bromide; by J. L. KREIDER .....	97
XIV.—Glacial (Dwyka) Conglomerate of South Africa; by E. T. MELLOR .....	107
XV.—Formation of Natural Bridges; by H. F. CLELAND ..	119
XVI.—Quartz from San Diego County, California; by G. A. WARING .....	125
XVII.—Radio-active Properties of the Waters of the Springs on the Hot Springs Reservation, Hot Springs, Ark.; by B. B. BOLTWOOD .....	128
XVIII.—Genesis of Riebeckite Rocks; by G. M. MURGOCI ..	133
XIX.—Purpurite, a new Mineral; by L. C. GRATON and W. T. SCHALLER .....	146

### SCIENTIFIC INTELLIGENCE.

- Chemistry and Physics*—Studies with the Liquid Hydrogen and Air Calorimeters. I. Specific Heats, J. DEWAR, 152.—Thermo-electric Junction as a Means of determining the Lowest Temperatures, J. DEWAR, 153.
- Geology*—Geology of the Vicinity of Little Falls, Herkimer County, H. P. CUSHING, 156.—Geology of the Watkins and Elmira Quadrangles, accompanied by a geologic map, J. M. CLARKE and D. D. LUTHER, 157.—Geologic map of the Tully Quadrangle, J. M. CLARKE and D. D. LUTHER, 158.—Contribution to the Paleontology of the Martinez Group, C. E. WEAVER: Faune cambrienne du Haut-Alemtejo (Portugal), J. F. N. DELGADO, 159.—Paraphorhynchus, a new genus of Kinderhook Brachiopoda, S. WELLER: Sympterura Minveri, n. g. et sp.; a Devonian Ophiurid from Cornwall, F. A. BATHER: Ancestral origin of the North American Unionidæ, or freshwater Mussels, C. A. WHITE, 160.—Thalattosauria, a group of marine reptiles from the Triassic of California, J. C. MERRIAM: Geology of Littleton, New Hampshire, C. H. HITCHCOCK: Vorschule der Geologie, J. WALTHER, 161.—Die Moore der Schweiz mit Berücksichtigung der gesammten Moorfrage, J. FRÜH and C. SCHRÖTER, 162.—Study of Recent Earthquakes, C. DAVISON: Introduction to the Geology of Cape Colony, A. W. ROGERS, 163.—Ice Erosion Theory, a Fallacy, H. L. FAIRCHILD, 164.—Hanging Valleys, I. C. RUSSELL, 165.—Glaciation of the Green Mountains, C. H. HITCHCOCK: Ice or Water, H. H. HOWORTH, 166.
- Miscellaneous Scientific Intelligence*—United States National Museum, R. RATHBUN: Forestry; Tenth Annual Report of the Chief Fire Warden of Minnesota, C. C. ANDREWS: Les Prix Nobel en 1902: Negritos of Zambales, W. A. REED: Magnetic Survey of Japan reduced to the Epoch 1895.0 and the Sea-level, A. TANAKADATE, 167.—Beiträge zur chemischen Physiologie, F. HOFMEISTER: Du Laboratoire à l'Usine, L. HOULLEVIGUE: Traité Complet de la Fabrication des Bières, G. MOREAU and L. LÉVY, 168.

Established by BENJAMIN SILLIMAN in 1818.

THE  
AMERICAN  
JOURNAL OF SCIENCE.

EDITOR: EDWARD S. DANA.

ASSOCIATE EDITORS

PROFESSORS GEORGE L. GOODALE, JOHN TROWBRIDGE,  
W. G. FARLOW AND WM. M. DAVIS, OF CAMBRIDGE,

PROFESSORS ADDISON E. VERRILL, HORACE L. WELLS,  
L. V. PIRSSON AND H. E. GREGORY, OF NEW HAVEN,

PROFESSOR GEORGE F. BARKER, OF PHILADELPHIA,

PROFESSOR HENRY S. WILLIAMS, OF ITHACA,

PROFESSOR JOSEPH S. AMES, OF BALTIMORE,

MR. J. S. DILLER, OF WASHINGTON.

FOURTH SERIES

VOL. XX—[WHOLE NUMBER, CLXX.]

No. 117.—SEPTEMBER, 1905.

WITH PLATES V-VIII.

NEW HAVEN, CONNECTICUT.

1905

THE TUTTLE, MOREHOUSE & TAYLOR CO., PRINTERS, 123 TEMPLE STREET.

Published monthly. Six dollars per year, in advance. \$6.40 to countries in the Postal Union. Remittances should be made either by money orders, registered letters, or bank checks (preferably on New York banks).

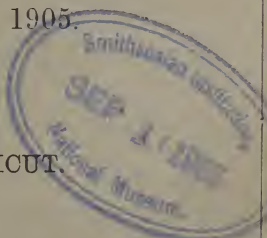

# CRYSTALLIZED STANNITE

A small consignment direct from the silver mines in Bolivia affords new and unique examples of the following. They have been identified by high mineralogical authority.

**Stannite, Splendent crystals**, grouped in cavities of the massive mineral. The crystals are most perfectly developed and very rich in planes. The species has been known to science for over a century, but until recently only in the massive form, thus leaving its crystallographic form in question. Hence the present find is peculiarly welcome.

**Andorite.** A silver and lead sulph-antimonide. Massive and in small but characteristic crystals of highly modified orthorhombic habit. Sometimes associated with the crystallized Stannite.

---

## RARE MINERALS

Specimens are supplied by us to students and chemists for purposes of comparison and investigation; in commercial quantities for industrial uses.

---

## SYSTEMATIC COLLECTIONS OF TYPICAL SPECIMENS

In sets of twenty-five up to fifteen hundred specimens. Prices \$5.00 upwards per set, the average price for students' specimens being about twenty cents. We have supplied the leading institutions for thirty years, having lately completed a single order for over 60,000 specimens. Our material is the accepted standard both as to correct labeling and high quality.

**Free Collection Catalog**, containing lists and illustrations of General Mineral Collections, Series of Ores for Prospectors, Sets of Crystals, Series illustrating Hardness and other Physical Characters of Minerals, with Price List of Laboratory Material and Individual Specimens.

---

## FOOTE MINERAL CO.,

Established 1876, by Dr. A. E. Foote.

W. M. FOOTE, Manager.

DEALERS IN

MINERAL SPECIMENS AND COMMERCIAL RARE MINERALS,

1317 Arch Street, Philadelphia.



THE  
AMERICAN JOURNAL OF SCIENCE

[FOURTH SERIES.]

---

ART. XX. — *Development of Fenestella*; by EDGAR ROSCOE CUMINGS, Ph.D. (With Plates V, VI, and VII.)

*Introduction.*

DURING the past two years, the writer's studies of the development of Paleozoic Bryozoa\* have brought out some very interesting points bearing upon the earliest stages of *Fenestella*. The present paper deals with the development (astogeny) and morphology of *Fenestella*, and is based entirely upon calcified material from the Hamilton formation of Thedford, Ontario.† This material consists of numerous bases of *Fenestella* colonies. In these, the minutest details of internal structure are preserved with remarkable fidelity. The method of study has been the preparation of both thin and serial sections. The latter were obtained by slowly grinding down the bases and accurately drawing each stage as seen by reflected or in some cases by transmitted light. The specimens studied are in various stages of growth. Some represent the bases of adult colonies from which the adult (ephebastic) portion has been lost; others are minute bases, which in their growth never proceeded farther than the nepiastic stage. In these nepiastic

\* In a former paper, a classification of the growth stages of the bryozoan colony was given, together with a general classification of the growth stages of any colony belonging to any group of organisms. The terms applicable to the growth stages of any colony are: *Nepiastic*, *neanastic*, *ephebastic*, and *gerontastic*, corresponding to the well-known terms *nepionic*, *neanic*, *ephebic*, and *gerontic*, applicable to the growth stages of the individual. Dr. Ruedemann has recently proposed the term *astogenetic* with reference to the colony, as the term parallel with *ontogenetic* with reference to the individual. The *astogenetic* stage of a colony, therefore, corresponds with the *ontogenetic* stage of an individual.

† This *Fenestella* is probably the form listed by Grabau as *Semicoscium labiatum*.

colonies, the zoëcia emerge upon the surface; but in the older ones, the apertures of the zoëcia in the basal portion are submerged in a copious deposit of punctate sclerenchyma. In all cases, however, there has been no resorption of the earlier zoëcia, so that sections of the bases of ephebastic or gerontastic zoaria reveal the morphology of the earliest stages as faithfully as sections of a nepiastic colony. As an aid to the elucidation of the astogeny of *Fenestella*, the writer studied the astogeny of *Retepora phænicea*, a recent bryozoan morphologically very similar to the ancient *Fenestellas* and *Polyporas*.

In the writer's former paper on the development of Paleozoic Bryozoa, the term *protæcium* was introduced as designating the primary individual of the colony. In this sense, it would have the same signification as the term *ancestrula* of Jullien or *primary cell* of Hincks. In the Cyclostomata, as is well known, the first zoëcium surmounts a hemispherical base (*basal disc*), which serves as the point of attachment of the young colony to the substratum. This basal disc has been shown to be the calcified wall of the metamorphosed and histolyzed embryo (Barrois and others). It is believed by the present writer that the persistence of this structure (kathembryonic stage) in the ancient order of Cyclostomata is not without significance, especially in view of the fact, to be shown presently, that it is a conspicuous feature in the development of the ancient Cryptostomata and possibly of the Trepostomata (*Phylloporina corticosa*). The basal disc is probably the *true* first zoëcium. In the present paper, therefore, the term *protæcium* is restricted to the basal disc or its equivalent, and the superjacent portion of the primary cell is designated the *ancestrula*. In many recent Chilostomata, there seems to be no distinction of *protæcium* and *ancestrula*. This may mean that the extreme acceleration of these modern types has practically eliminated the *protæcium* from the ontogeny. In the ancient Cryptostomata, on the other hand, the *protæcium* greatly predominates over the *ancestrula*, which is often little more than an exaggerated aperture to the former. In any case, the ontogenetic stage of which the *protæcium* is the index is always present throughout the Ectoprocta, for by a degenerative metamorphosis they all give rise to a hemispherical kathembryo, from which the adult polypide arises by a sort of budding process. Furthermore, this kathembryo becomes invested with a calcareous or chitinous ectocyst, which is the first skeletal structure of the developing individual. The *protæcium* is therefore very closely analogous to the protegulum of brachiopods, the protoconch of cephalopods, etc.

## DEVELOPMENT OF FENESTELLA.

*The Protœcium.*

Many well-preserved *Fenestella* bases show a minute circular pit on their basal surface. This can be seen only in colonies that were attached to a substratum which disappeared in the process of fossilization, leaving the basal surface of the colony free from all extraneous matter. Where the colony is still attached to the substratum, frequently the frond of another bryozoan, the circular pit can always be demonstrated by means of thin sections. This pit is the protœcium. As will be seen from the longitudinal sections (figs. 20, 36, 37, 59), the protœcium is separated from the substratum by a thin basal membrane. In such sections, this pit appears as a semi-circular object in the proximal portion of the colony. In transverse sections, it appears as a dark ring surrounded by concentric zones of punctate secondary sclerenchyma. That the protœcium has its own proper wall, similar to that of ordinary zoœcia, is shown by numerous sections (figs. 36–38, and 59). The diameter of the protœcium is from 0.4–0.6<sup>mm</sup>, or about three or four times that of the ordinary zoœcia. In form and position it corresponds precisely to the basal disc of Cyclostomata, and there can be little doubt that it has the same morphological and developmental significance.

*The Ancestrula.*

The protœcium is surmounted by a tubular structure arising from the center of its distal surface. This is the ancestrula. In some of the earlier sections prepared by the writer, one of the primary buds was mistaken for the ancestrula, and its size and shape were therefore thought to be different from what was shown in later sections. It is considerably smaller than the primary buds, being both shorter and of less diameter. It seems altogether likely that the primary polypide never permanently ascended into the ancestrula as in the Cyclostomata. On the other hand, the ancestrula of *Fenestella* is far from being the homologue of the vestibule of ephebastic zoœcia. It is not built up of secondary deposits, but is composed of the same thin non-punctate substance as the proper wall of the protœcium and other zoœcia. The homology of the ancestrula of *Fenestella* is with the tubular primary zoœcium of the Cyclostomata. Figures 59 and 60 indicate the shape and appearance of the ancestrula, as seen in the majority of properly orientated longitudinal sections,\* and figures 10–13, 24, 43, and 54 in transverse sections.

\* The zoœcium marked *I*, in figures 19 and 20, was at first thought to be the ancestrula, since it communicates freely with the protœcium. A careful study of the appearances possible in a series of longitudinal sections with

*The Primary Buds.*

Two lateral primary buds arise from the primary zoecium (figs. 3-7, 21-23, 40-43). There is still some question as to whether these buds arise from the protœcium or from the ancestrula. The sections figured reveal all that can be expected. The question becomes one of interpretation and of analogy with recent Bryozoa. The proximal ends of the primary buds are in contact with the protœcium and are separated from its cavity by a very thin calcareous wall, which is frequently broken away (figs. 19 and 20). The appearance of this wall is well shown in figure 36. Figures 3-7 and 38-40, 42 show the intimate relation of the primary buds to the protœcium. From the analogy of recent Bryozoa, on the other hand, these buds might be expected to originate from the ancestrula. A median primary bud is not indicated by any of the sections. If it existed, it certainly arose from the ancestrula.

The size, shape, and position of the primary buds is beautifully shown in figures 38 and 39, and in the transverse sections. These buds are long and tubular, and diverge but slightly from the axis of the zoarium. There is no long vestibule as in ephebastic zoecia, but the whole aspect of the buds is that of a simple tubular zoecium, quite similar to that of the Cyclostomata. There is also no indication of hemisepta or any other structures within the zoecium.

*Secondary Buds.*

All buds of the second generation from the protœcium are designated secondary buds. The series of sections (figs. 1-16) seems to indicate that each of the primary buds produces a lateral and a median bud. The lateral buds are very clearly shown in such a position that they could have originated from no other source than from the primary buds (see especially figs. 5, 41, and 42). The median buds belong to the second tier of zoecia. They are designated  $II_{21}$  and  $II_{22}$  in figure 13. The shape of the secondary buds is quite similar to that of the primary ones (figs. 37, 45, 59, and 60). Figure 50 is a drawing different assumed orientation has convinced the writer that the zoecium in question is a primary bud. To test this, four different bases in which the protœcium and primary buds could be seen on the basal surface (in some cases only after slight etching) were sectioned in the direction  $j-j$ , figure 48, which had been determined by previous inspection of the basal surface, and marked by carefully drawing a fine line through the center of the protœcium and as nearly as possible between the primary buds. Every one of these sections has the appearance shown in figures 59, 60, and 45. It is therefore unlikely that figures 19 and 20 (which were orientated at random) represent the ancestrula. It is needless to state that only a very small proportion of the many sections prepared in this study are figured.

of a secondary bud, and may be compared with figure 53, which is a drawing of two zoëcia of *Protoerisina* (after Ulrich), a cyclostomatous bryozoan from the Trenton. The resemblance is too striking to need further emphasis. No internal zoëcial structures have been observed in the secondary buds.

#### *Tertiary and Later Buds.*

One bud of the third generation from the ancestrula occupies a position in the first tier of zoëcia, diametrically opposite the ancestrula (*III*, figs. 6-13, 24, 26, 43, 54-58). The shape of this bud is well shown in figures 37, 45, 59, and 60. There is no means of telling from which of the two secondary buds this tertiary one is derived. It may have originated now from one, now from the other. In figure 43, it is rather more intimately associated with 32, which was in turn derived from the right lateral primary bud. Figure 13 indicates that each of the secondary buds gives rise to a median bud lying in the second tier of zoëcia.

Ascending the axis of the zoarium (figs. 17-20, 36-39), there is exhibited a series of zoëcia very symmetrically arranged about the axis. In transverse sections, above the level of *y*, figure 17, these present a peculiar star-shaped appearance seen in figures 15, 16, and 58, as well as in figure 61 of the writer's former paper. The order of budding of these later zoëcia cannot be determined, although the writer has devoted a large amount of time and study to this point. It is probable that the order of budding in these later generations is without significance. An important point shown by the sections, however, is the shape and size of these zoëcia. This is best seen in figures 17 and 38. The zoëcia are tubular, but somewhat less elongate than the earlier ones. It is not until the zoarium begins to expand into its characteristic infundibular form that the zoëcia assume the shape normal to *Fenestella*. Figure 51 shows a row of zoëcia from the neanastic region (base of the cone) of the specimen represented in figure 38. For comparison with this is inserted figure 52, showing a specimen of *Fenestella acmea* from the Waldron shale of Tarr Hole, Indiana. The resemblance is striking. The adult zoëcia of the Thedford *Fenestella* are shown in figure 49.

#### *Discussion and Conclusions.*

The morphological element of the bryozoan colony which corresponds to the primitive integument of Mollusca, Brachiopoda, etc. (that is, to the protoconch, protogulum, etc.), is the *protæcium*, or basal disc, of the primary individual of the colony. The protecium is the calcareous or chitinous wall of

the kathembryo. In *Fenestella* it is very large and in every way similar to the protœcium (basal disc) of the Cyclostomata. The ancestrula is the tubular superstructure of the primary individual. It is a simple, undifferentiated, tubular zoœcium. The earlier formed zoœcia (nepiastic zoœcia) of the *Fenestella* colony differ markedly in shape and size from later formed (neanastic and ephebastic) zoœcia. In every feature in which they depart from the ephebastic zoœcia of *Fenestella* they approach the ephebastic zoœcia of the Cyclostomata.

From these observations, it may be reasonably concluded that *Fenestella* as well as the entire order of Cryptostomata is derived from the Cyclostomata. Certain other general conclusions, more or less speculative, are suggested by a consideration of the probable significance of the protœcium and ancestrula.

The meaning of the degenerative metamorphosis of Bryozoa has always been a puzzle to students of this class. The striking analogy of this metamorphosis to the degeneration of an ordinary polypide and production of a brown body, together with the nearly identical life history of the regenerating polypide or of ordinary buds and the primitive polypide issuing from the kathembryo, have more than once led to the suggestion that the primitive polypide is in the true sense a bud. The writer is inclined to hold this view. Assuming, therefore, that the primitive polypide is a bud, the following suggestions may be made in regard to the significance of the metamorphosis and of the resulting protœcium:

1. In the primitive bryozoan, there was no histolysis of the larval organs. The development was direct and resulted in a primitive zoœcium and polypide.

2. This primitive zoœcium was hemispherical in shape and possessed a simple aperture in the center of its upper surface. Some ancient types of Cyclostomata retain nearly such a form of zoœcium (*Stomatopora* of the Trenton, especially *S. turgida*).

3. This primitive zoœcium might now give rise to a linear adnate series of zoœcia, as in *Stomatopora*, or to a series of superposed zoœcia, as in the Trepostomata. By variations of zoarial habit based upon one or the other of these fundamental plans of budding all existing types of Bryozoa could have been produced.

4. In accordance with the law of tachygenesis, later in the history of the bryozoan group a tendency toward concentration of the early stages in development would arise. In any colony the tendency to degenerate may be supposed to have applied to the primitive polypide as well as to later ones, and finally to have become an invariable part of its life history. By the continued operation of the law of tachygenesis, the life history of the first polypide became so abbreviated as to be

represented only by its degenerative stage, that is, by its latest growth stage, all the earlier growth stages having been crowded out or back into the larval stage.

In accordance with this interpretation of bryozoan development, the large size of the protœcium in ancient types is explicable and is thought to be due to a less degree of acceleration, the calcification of the zoœcial wall of the primitive individual being allowed to proceed nearly to completion before the second zoœcium was superposed upon it. The probability that the first polypide remains in the protœcium in *Fenestella*, instead of ascending into the ancestrula as in modern Cyclostomata, may indicate a still more primitive condition. The relations of the protœcium and ancestrula in the Cyclostomata and in *Fenestella* suggest the normal relation of superposition of the zoœcia in the Trepostomata. It is not without interest to find evidence, in the development of Paleozoic Bryozoa, of the fundamental relationship of these great groups. Ulrich (Geol. Surv. Illinois, vol. viii) has already suggested such a relationship on the ground of the resemblances of such types as the early *Fenestellas*, *Phylloporina* and *Protocrisina*. The evidence presented by these adult types is greatly strengthened by the striking parallelism of the nepiastic stages of *Fenestella* with the series of adult types named above.

Paleontological Laboratory, Indiana University,  
June, 1905.

#### EXPLANATION OF PLATES.

##### *Description of Figures.\**

Letters having the same meaning for all the figures:—

- a, b, c, d, e*, primary carinæ (except figs. 17, 24, 47, and 48).
- f*, fenestrule.
- k*, carina.
- o*, protœcium.
- s*, substratum of bryozoan colony.
- z, z'*, etc., zoœcia of generations later than the primary zoœcia.
- A*, ancestrula.
- I*, primary bud.
- II*, bud of second generation, that is, derived from a primary bud.
- III*, bud of third generation.
- 2*, left lateral bud.
- 3*, right lateral bud.
- 23*, right lateral bud of the second generation, derived from a left lateral primary bud.
- 32*, left lateral bud of the second generation, derived from a right lateral primary bud.

\* All drawings except figures 1-16 were made with the camera lucida. Figures 30-32 are after Barrois, and figure 53 is after Ulrich. All the specimens of *Fenestella* are from Thedford, Ontario.

## PLATE V.

- FIGURES 1-16.—Transverse serial sections of a *Fenestella* base. These sixteen sections represent 1<sup>mm</sup> thickness of rock.
- FIGURES 1, 2.—Protœcium (cf. figs. 40, 41, 31-35).
- FIGURE 3.—Section in the plane of *a-a*, figure 47, cutting the proximal ends of the primary buds and the buds of the second generation (secondary buds) (cf. fig. 42).
- FIGURES 4, 5.—Successively higher sections.
- FIGURE 6.—Section in plane of *a'-a'*, figure 47, cutting the proximal end of the tertiary bud (cf. fig. 43).
- FIGURES 7-12.—Successively higher sections between the planes of *a'-a'* and *c-c*, figure 47, showing the development of the initial buds. Figures 10-12 cut the aperture of the ancestrula (cf. fig. 24. with fig. 12).
- FIGURE 13.—Section cutting the proximal ends of buds of the second tier (*II<sub>31</sub>*, *II<sub>31</sub>*, *III<sub>b</sub>*, and *III<sub>c</sub>*) (cf. fig. 26).
- FIGURE 14.—Section just cutting the distal end of the aperture of the ancestrula.
- FIGURES 15, 16.—Assumption of the star-shaped arrangement of zoecia, characteristic of the paranepiastic stage of *Fenestella*.

## PLATE VI.

- FIGURE 17.—Longitudinal section of a *Fenestella* base cutting in the plane of *e-e*, figure 47, and *a-a*, figure 48. This section passes through the edge of the protœcium and misses the ancestrula entirely. *b, b'*, buds of the second tier. At *z* and *z'* the zoecia are vertically above each other; at *z''*, *z'''* they alternate, and at the top of the figure they lie side by side. × 17.
- FIGURE 18.—Longitudinal section cutting still more excentrically than that shown in figure 17, probably in the plane of *b-b*, figure 48. This misses the protœcium and ancestrula entirely, but their relative position is shown at *o* and *A*. The vertical alignment of zoecia is shown at *z-z'* and the ordinary arrangement, on either side of the carina, at *z''*. The bifurcation of a primary branch is shown at *g-h* (between *z''* and *g, h*). In each new branch, the zoecia first alternate and later lie side by side. Normal arrangement shown at *k' k''*. × 17.
- FIGURE 19.—Longitudinal section cutting in the plane of *c-c*, figure 48. The section cuts a row of zoecia (*z'-z''*) nearly longitudinally. × 17.
- FIGURE 20.—Section in nearly the same plane as in figure 19 (*d-d*, figure 48). This section was orientated by polishing and etching the basal surface of the colony and marking the position of the protœcium and primary buds. The section was then ground as nearly as possible in the marked direction. A primary bud is very clearly shown (*I*). × 17.
- FIGURE 21.—Transverse section in the plane of *a-a*, figure 47. The primary buds are very distinct. × 17.
- FIGURE 22.—Similar section of another specimen, cutting the proximal end of the ancestrula. × 17.
- FIGURE 23.—Transverse section of a very slender base. Section in about the same plane as 22. × 17.
- FIGURE 24.—Section in the plane of *b-b*, figure 47. Ancestrula very distinct. × 17.
- FIGURE 25.—Longitudinal section of a base from which the substratum was absent. × 17.
- FIGURE 26.—Transverse section in the plane of *d-d*, figure 47, showing the proximal ends of two buds of the second tier (*z, z'*) (cf. fig. 13). × 17.
- FIGURE 27.—Protœcium and ancestrula of *Retepora phœnicea* from St. Vincent's Gulf, Australia. × 27.
- FIGURE 28.—Ancestrula and three primary buds (*1, 2, 3*) of *Retepora phœnicea*. × 29.
- FIGURE 29.—Profile view of protœcium and ancestrula of another specimen of *Retepora phœnicea*. × 27.



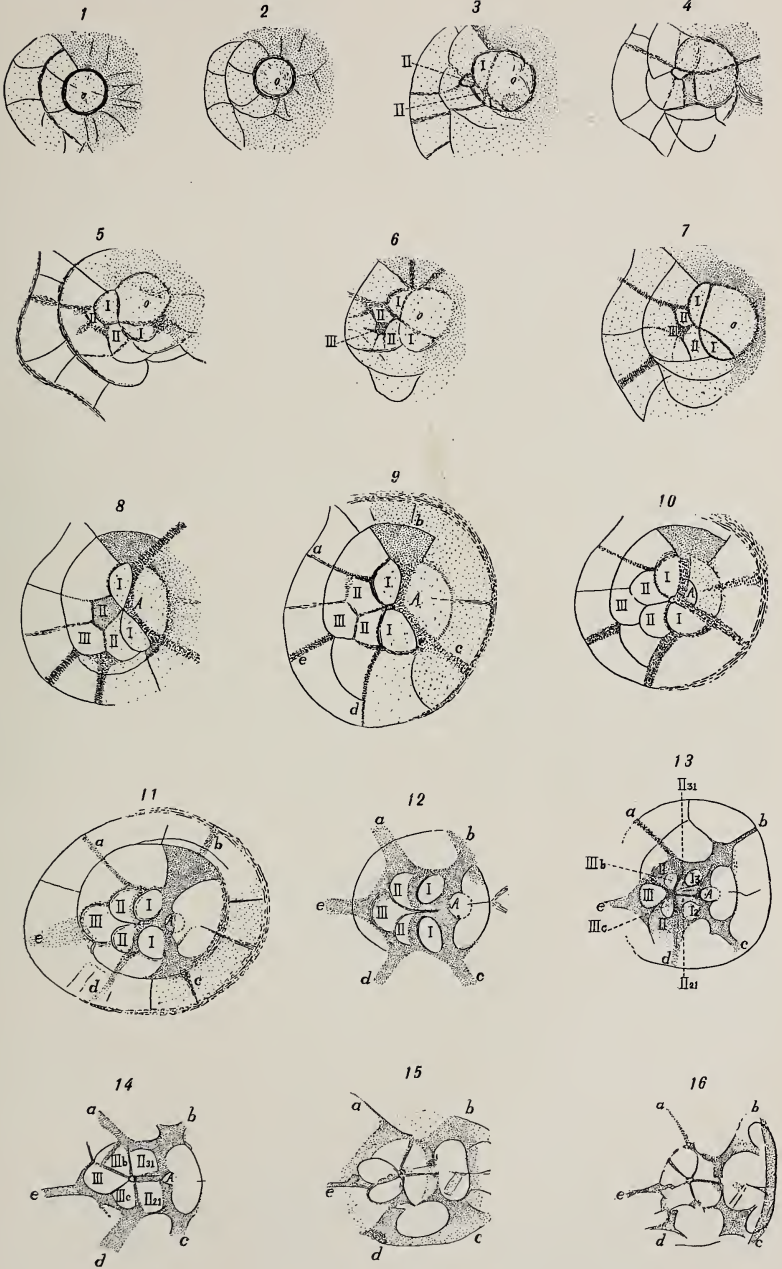

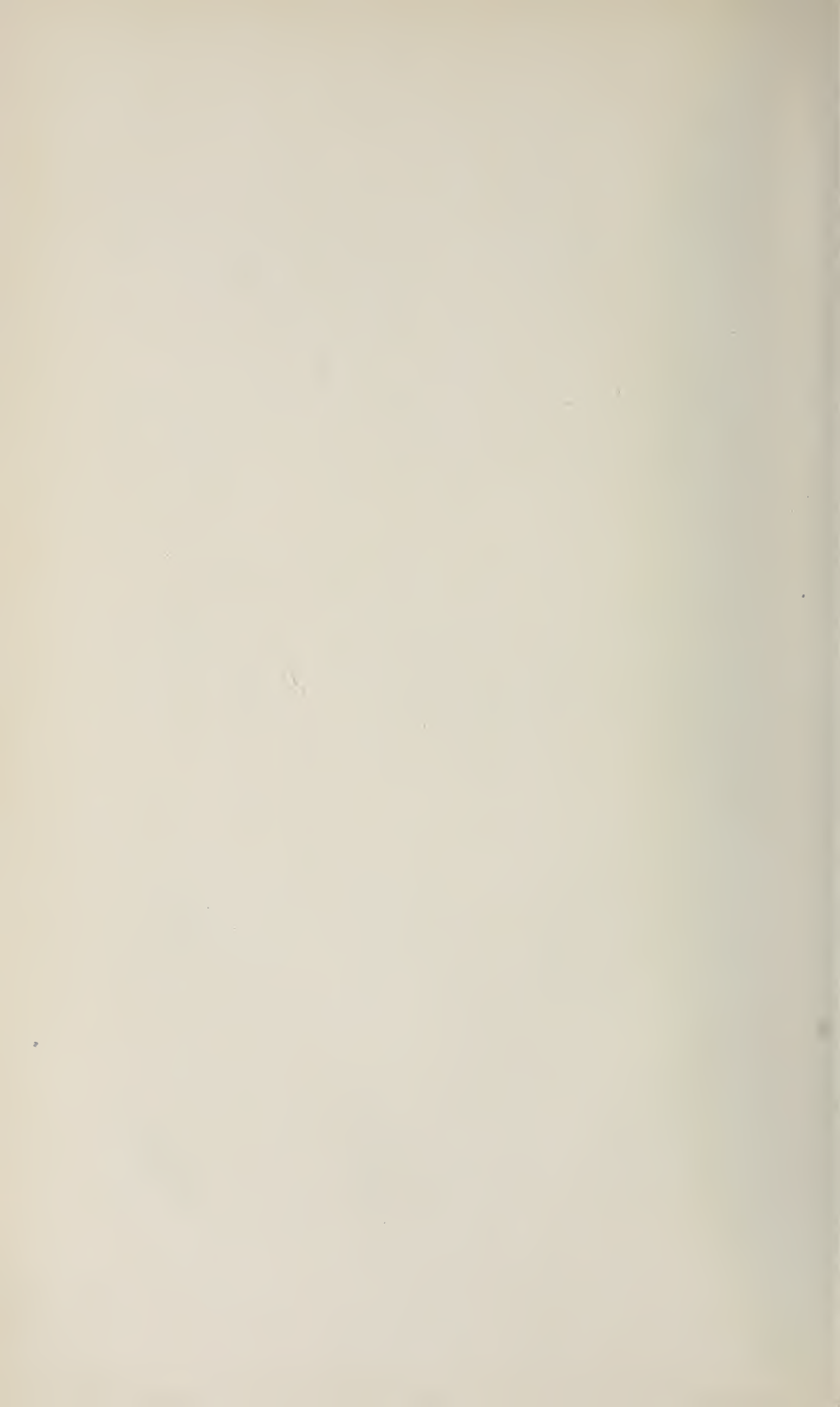

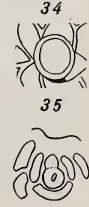
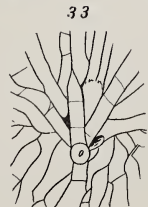
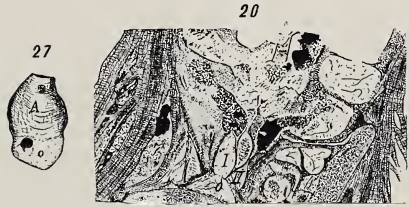
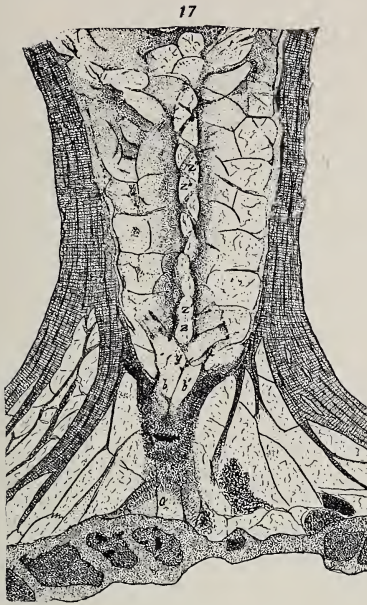

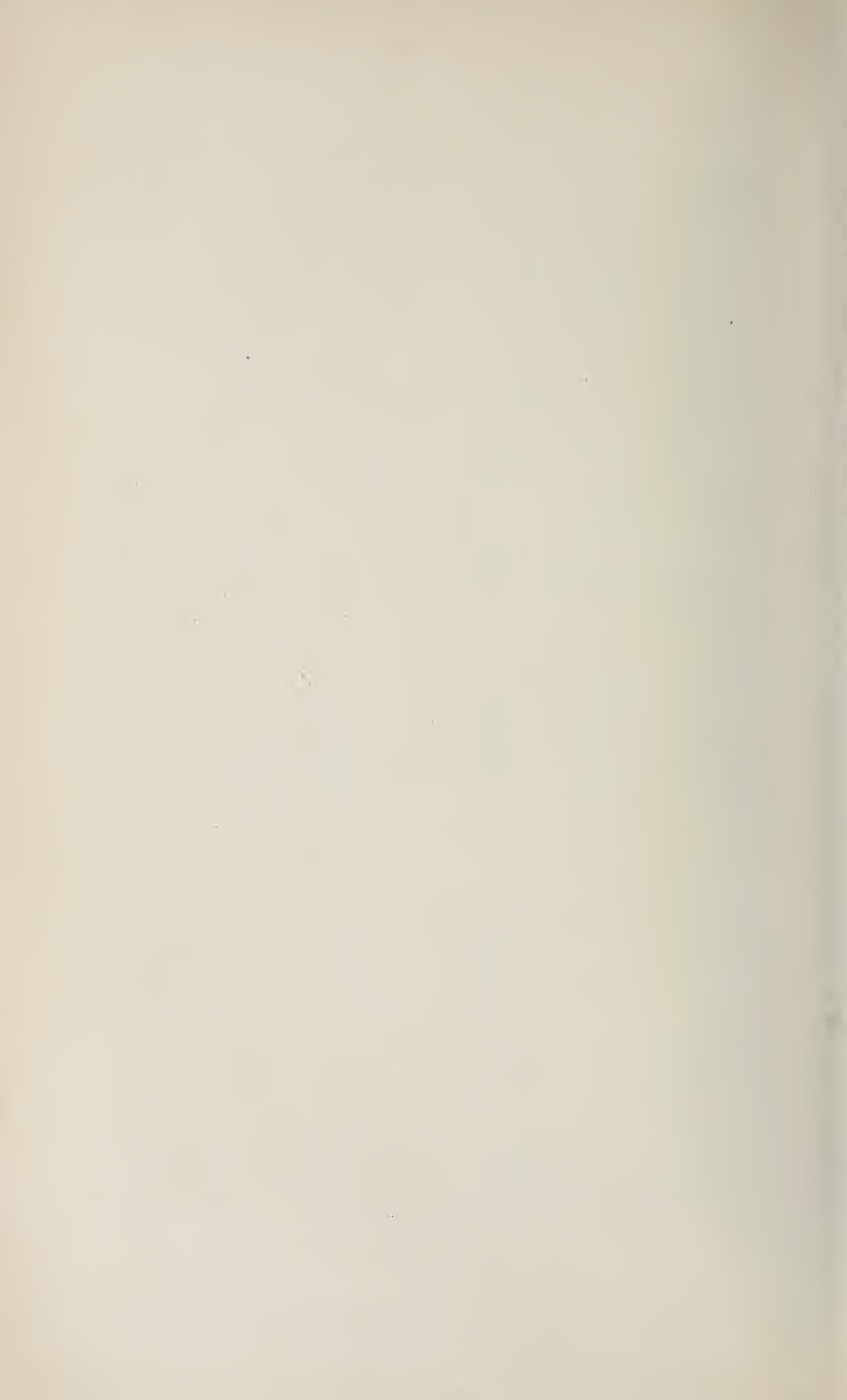

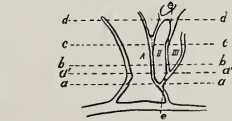
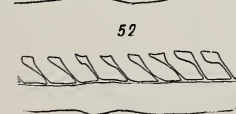
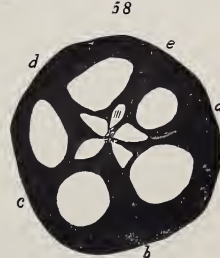
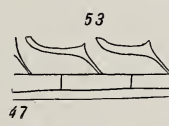
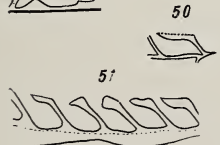
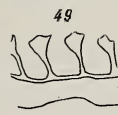
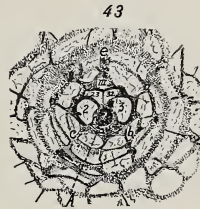
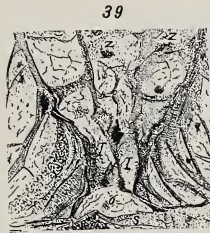
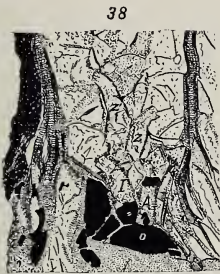
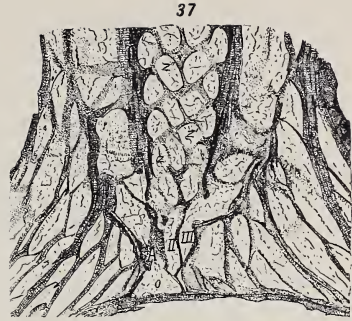



- FIGURE 30.—Protœcium, ancestrula, and primary bud of *Tubulipora*. After Barrois.  $\times 27$ .  
 FIGURE 31.—Same; seen from the under surface.  $\times 27$ .  
 FIGURE 32.—Ancestrula and primary bud of *Schizoporella*.  $\times 33$ .  
 FIGURE 33.—Protœcium and primary zoœcia of *Phylloporina corticosa* from Cannon Falls, Minnesota.  $\times 17$ .  
 FIGURE 34.—Protœcium of *Polypora* from the Lower Helderberg of Indian Ladder, New York.  $\times 28$ .  
 FIGURE 35.—Protœcium of *Thamniscus* from the Upper Coal Measures of Kansas.  $\times 17$ .

PLATE VII.

- FIGURE 36.—Longitudinal section of *Fenestella*, in the plane of *f-f*, figure 48.  $\times 17$ .  
 FIGURE 37.—Longitudinal section in the plane of *g-g*, figure 48.  $\times 17$ .  
 FIGURE 38.—Longitudinal section in the plane of *h-h*, figure 48. This section shows remarkably well the shape of the nepiastic zoœcia.  $\times 17$ .  
 FIGURE 39.—Longitudinal section in the plane of *i-i*, figure 48.  $\times 17$ .  
 FIGURE 40.—Transverse section in the plane of *a-a*, figure 47. Shows the primary buds (*2, 3*).  $\times 17$ .  
 FIGURE 41.—Transverse section of another specimen in which the primary and secondary buds have a rather unusual arrangement.  $\times 17$ .  
 FIGURE 42.—Transverse section in the plane of *a'-a'*, figure 47 (cf. fig. 5). Same specimen as figures 54-58.  $\times 17$ .  
 FIGURE 43.—Transverse section in the plane of *b-b*, figure 47. Shows the proximal end of the tertiary bud (cf. fig. 10).  $\times 17$ .  
 FIGURE 44.—Probable interpretation of figure 39. Section in the plane of *i-i*, figure 48.  
 FIGURE 45.—Semidiagrammatic drawing of a longitudinal section (in the plane of *j-j*, fig. 48) of a specimen showing the ancestrula and two zoœcia, probably one of the secondary buds and a tertiary bud (*II, III*).  $\times 17$ .  
 FIGURE 46.—Semidiagrammatic drawing of a longitudinal section (in the plane of *k-k*, fig. 48) of the ancestrula and protœcium of another specimen.  $\times 17$ .  
 FIGURE 47.—Semidiagrammatic drawing from figure 37, to show the position of transverse sections.  
 FIGURE 48.—Semidiagrammatic drawing from figure 43, to show the position of longitudinal sections.  
 FIGURE 49.—Epebastic zoœcia of *Fenestella*. Specimen from Thedford, Ontario.  $\times 17$ .  
 FIGURE 50.—Nepiastic zoœcium of *Fenestella*. Specimen from Thedford, Ontario.  $\times 17$ .  
 FIGURE 51.—Neanastic zoœcia of *Fenestella*. From the proximal portion of the cone of the same specimen as that shown in figure 38.  $\times 17$ .  
 FIGURE 52.—Epebastic zoœcia of *Fenestella acmea* from the Waldron shale of Tarr Hole, Indiana (cf. fig. 51).  $\times 17$ .  
 FIGURE 53.—Epebastic zoœcia of *Protoerisina exigua* Ulr. from the Trenton limestone of Montreal, Canada (cf. fig. 50). After Ulrich.  $\times 18$ .  
 FIGURES 54-58.—Serial sections of a *Fenestella* base. Same specimen as that shown in figure 42, figure 54 being the next section above. Figures 55-58 are successively higher sections.  $\times 17$ .  
 FIGURE 59.—Longitudinal section (in the plane of *j-j*, fig. 48) of a *Fenestella* base, showing the shape of the ancestrula most often seen, and three nepiastic zoœcia (*II, III, z'*).  $\times 17$ .  
 FIGURE 60.—Semidiagrammatic drawing from figure 59.

ART. XXI.—*Age of the Monument Creek Formation*;\* by  
N. H. DARTON.

THIS contribution is an account of additional evidence as to the Oligocene age of the Monument Creek formation, or at least of its upper member, afforded by the discovery of Titanotherium and other fossil bones at several localities.

On the high divide between the Platte and Arkansas drainage basins, at the foot of the Rocky Mountains, there is an extensive deposit of sands, gravel and clay to which F. V. Hayden gave the name of Monument Creek group.† This observer recognized the fact that the group overlies the Laramie formation unconformably, but apparently he included in its lower portion more or less of the beds later separated, as the Arapahoe and Denver formations in the Denver region. The opinion was held that it was of early Tertiary age, but no precise correlation was suggested. In 1873, Prof. E. D. Cope examined a portion of the deposit and found a few bones in regard to which he made the following statement:‡

“The age of the Monument Creek formation in relation to the other Tertiaries not having been definitely determined, I sought for vertebrate fossils. The most characteristic one which I procured was the hind leg and foot of an *Artiodactyle* of the Oreadon type, which indicated conclusively that the formation is newer than the Eocene. From the same neighborhood and stratum, as I have every reason for believing, the fragment of the *Megaceratops coloradoensis* was obtained. This fossil is equally conclusive against the Pliocene age of the formation, so that it may be referred to the Miocene until further discoveries enable us to be more exact.”

Doubtless Professor Cope regarded the fauna as belonging in the White River group, which is now generally considered to be Oligocene. He added nothing regarding the precise locality, or stratigraphic position of the fossils. So far as I can find, no further paleontological evidence has since been offered, regarding the age of the formation. A brief account of the Monument Creek formation was given by G. H. Eldridge, in the “Geology of the Denver Basin.”§ The true stratigraphic limits of the formation in relation to the underlying

\* Published by permission of the Director of the United States Geological Survey.

† Preliminary field report of U. S. Geological Survey of Colorado and New Mexico, 1869, p. 40.

‡ [7] Annual Report of the United States Geological and Geographical Survey of the Territories, embracing Colorado, Report for 1873, by F. V. Hayden, p. 430.

§ United States Geological Survey, Monographs, vol. xxvii, pp. 252-254.



Laramie, Arapahoe and Denver formations were recognized, and it was shown that the formation consists of two distinct members separated by a well-defined break in deposition. The lower member lies on an uneven floor of Denver formation at the north and Laramie to the southeast. It displays "marked regularity in the succession of its beds, excepting at the base, where, owing to the uneven floor, the material varies from conglomerate through sandstone to arenaceous shale. A short distance above the base are two broad bands of green shale separated by one of pink and capped by a fine grit, or sandstone, which is soft and friable and easily disintegrates." The thickness is estimated to be about 900 feet. The sandstones and grits of the lower member are mostly of granite debris. The upper member consists of sandstones and shales, with numerous beds of conglomerate, and between the two there are local deposits of rhyolitic tuff, in places 40 feet thick, which are quarried extensively for building stone near Castle Rock. In the lower part of the upper member many fragments of this rhyolitic tuff occur, a feature which is notably displayed in the breccia and conglomerate capping the butte known as Castle Rock. The thickness of the upper member is estimated by Eldridge at about 400 feet. In portions of the area, I have observed that in the lower member there are extensive deposits of massive clay, very similar in appearance and properties to the fullers earth which is characteristic of the Chadron formation, or Titanotherium beds, of the White River group in the Big Bad Lands of South Dakota and elsewhere.

In the general résumé of the geology in the Monograph on the Denver Basin,\* Mr. Emmons suggests that the vertebrate remains of Miocene age probably were from the lower member of the formation and that the upper member might be correlated with the Pliocene. This suggestion was based on the fact that the uppermost Tertiary deposits in the eastern portion of Colorado are of Pliocene age, and in the region north of the Platte River they lie unconformably on White River beds. Mr. Emmons recognized the fact that these beds differ somewhat from Monument Creek beds in character, yet this could be explained by the proximity of the Monument Creek formation to shore lines along the mountain front.

Two years ago, while examining the southern portion of the Monument Creek area, I obtained from the conglomerate four miles northwest of Calhan, the distal end of a large humerus which Dr. F. A. Lucas has identified as Titanotherium. This conglomerate is the upper member of the formation and caps a long line of buttes and extensive plateaus. A number of

\* Loc. cit., p. 39.

bones have also been collected for me along the valley of Cherry Creek, half way between Castle Rock and Elizabeth, consisting mainly of bones of titanotherium. They were obtained at many localities and all from the sandstones of the upper member of the formation. A fragment of a lower jaw of titanotherium was the most distinctive fossil obtained. It was found in the upper beds, at Kaumpfer's ranch, 7 miles southwest of Elizabeth. In Wild Cat Canyon, 6 miles west-by-south of Elizabeth, were found fragments of a jaw and the distal ends of a titanotherium tibia and humerus. Portions of a lower jaw of hyracodon, apparently *nebrasensis*, were found in a well at Anderson's place 6 miles south-southwest of Elizabeth, together with various turtle bones. All of this material appears to have been obtained from the upper beds and it correlates these beds with the Chadron formation of the White River group, or Oligocene. No evidence was obtained as to the age of the lower member, but the fullers earth, as before mentioned, is similar to that which is so characteristic in other areas. The presence of the unconformity between the upper and lower members suggests that the latter may be of Wasatch or Bridger age. The nearest locality to the Monument Creek area, at which Oligocene deposits occur in eastern Colorado, is in the vicinity of Akron and Fremont's Butte, where titanotherium remains occur in abundance. Farther north, in the region about Pawnee Buttes, there are well-known localities of the titanotherium and overlying beds. In the low intervening area, east and southeast of Denver, Oligocene deposits are absent, but it is probable that originally they extended continuously from the vicinity of Akron to the foot of the Rocky Mountains in the Monument Creek area. There is much evidence throughout the Great Plains region that the Oligocene deposits were originally of wide extent, for outliers occur along the mountain slopes and in many widely separated areas. They have been subjected to extensive degradation in Miocene, Pliocene and later times and probably removed from large districts, especially in the wider valleys. In my recent report on the Great Plains,\* there is given a map showing their present distribution and probably former great extent.

\* United States Geological Survey, Professional Paper No. 32, pl. xlv.

ART. XXII.—*The Iodometric Determination of Aluminium in Aluminium Chloride and Aluminium Sulphate*; by S. E. MOODY.

[Contributions from the Kent Chemical Laboratory of Yale Univ.—cxxxviii.]

A PROCESS for the gravimetric determination of alumina in salts of aluminium has been described by Stock,\* who bases the method upon the reaction represented by the following equation:

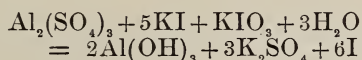

This equation would show that iodine is liberated when potassium iodate and potassium iodide are together added to a solution of aluminium sulphate. It was found, however, that in the action of the iodide-iodate mixture upon a solution of potassium alum, only about two-thirds of the iodine corresponding to the aluminium salt is accounted for; and this suggests that the reaction is not completed according to the equation, and that the precipitate formed is not the simple hydroxide. Upon ignition the precipitate yields, however, the total amount of alumina present; and, since the character of the precipitate is good, the process is easily managed and gives, as Stock has said, an excellent gravimetric method for the determination of alumina.

Taking aluminium chloride,  $\text{AlCl}_3 \cdot 6\text{H}_2\text{O}$ , and proceeding in the same manner, similar results are obtained, and after dissolving the precipitate in sulphuric acid and adding silver nitrate to the dilute solution, a decided precipitate of silver chloride is observed, which upon washing, drying and weighing is found to be about one-third of the amount of that substance corresponding to the original aluminium chloride. This indicates that it is an oxychloride which is formed on the addition of potassium iodide and iodate; moreover, upon removing by sodium thiosulphate the iodine first set free in the action and allowing the mixture to stand, progressive hydrolysis takes place as shown by the return of color due to iodine, and this change can be still further hastened by heating after adding an excess of sodium thiosulphate to take up the iodine as liberated. The attempt was made, therefore, to complete the reaction between the iodide-iodate mixture and the aluminium chloride, or alum, by heating the solution in a Voit flask through which steam or, still better, hydrogen was passed, as an aid in the transfer of the iodine liberated to a receiver

\* Ber. Dtsch. Chem. Ges., 1900, xxxiii, i, p. 548.

charged with a solution of potassium iodide. The iodine collected was titrated with  $\frac{n}{10}$  sodium thiosulphate.

Table I gives results obtained by this method. The details of the experiments in which steam was used as an agent to force the iodine over are given in section A, while those of the experiments in which hydrogen was employed are indicated in section B.

TABLE I.

Approx. $\frac{n}{10}$ Aluminium chloride solution. cm <sup>3</sup> .	HIO <sub>3</sub> . grm.	KI. grm.	Time in minutes. A	Approx. $\frac{n}{10}$ Na <sub>2</sub> S <sub>2</sub> O <sub>3</sub> . cm <sup>3</sup> .	Al <sub>2</sub> O <sub>3</sub> calculated grm.	Diff. grm.
25	0.3	1.0	25	25.05	0.0427	-0.0007
25	0.3	1.0	90	25.15	0.0428	-0.0006
B						
25	0.3	1.0	20	25.05	0.0427	-0.0007
25	0.3	1.0	15	25.10	0.0428	-0.0006
25	0.3	1.0	15	25.00*	0.0426	-0.0009
25	0.3	1.0	15	25.00*	0.0426	-0.0009

In each of these experiments the iodide-iodate mixture was made by exactly neutralizing iodic acid with potassium hydroxide, adding a minute crystal of the iodic acid, introducing the potassium iodide in solution and taking up with a drop or two of sodium thiosulphate the iodine set free. This mixture was put into the Voit flask together with the aluminium chloride, and the whole was heated in the current of steam or hydrogen.

Applying the process to a solution of potassium alum the results recorded in the following table were obtained.

TABLE II.

Approx. $\frac{n}{10}$ Aluminium potassium alum. cm <sup>3</sup> .	KIO <sub>3</sub> . grm.	KI grm.	Time in minutes.	Approx. $\frac{n}{10}$ Na <sub>2</sub> S <sub>2</sub> O <sub>3</sub> . cm <sup>3</sup> .	Al <sub>2</sub> O <sub>3</sub> calcu- lated. grm.	Al <sub>2</sub> O <sub>3</sub> found. grm.	Diff. grm.
25	0.3	1.0	30	24.55	0.0410	0.0414	-0.0004
25	0.3	1.0	30	24.60	0.0411	0.0416	-0.0005
25	0.3	1.0	25	24.50	0.0409	0.0414	-0.0005
25	0.3	1.0	30	24.70	0.0413	0.0416	-0.0003
25	0.3	1.0	35	24.50	0.0409	0.0415	-0.0006
25	0.3	1.0	30	24.55	0.0410	0.0415	-0.0005
25	0.3	1.0	25	24.50	0.0409	0.0415	-0.0006

\* New standard.

In Table III are shown results of the application of the process to an ammonium alum.

TABLE III.

Approx. $\frac{n}{10}$ Ammonium alum. cm <sup>3</sup> .	KIO <sub>3</sub> . gram.	KI. gram.	Time in minutes.	Approx. $\frac{n}{10}$ Na <sub>2</sub> S <sub>2</sub> O <sub>3</sub> . cm <sup>3</sup> .	Al <sub>2</sub> O <sub>3</sub> calculated gram.	Diff. gram.
25	0·3	1·0	20	25·20	0·0429	+0·0007
25	0·3	1·0	15	25·17	0·0429	+0·0007
25	0·3	1·0	20	25·10†	0·0427	+0·0005
25	0·3	1·0	25	25·20†	0·0429	+0·0007
25*	0·3	1·0	12	25·70†	0·0421	-0·0001
25*	0·3	1·0	12	24·65†	0·0420	-0·0002
25	0·3	1·0	20	25·20†	0·0430	+0·0008
25	0·3	1·0	25	25·15†	0·0429	+0·0007
25	0·3	2·0	25	25·20†	0·0430	+0·0008
25	0·3	2·0	20	25·15†	0·0429	+0·0007

These results proved to be too high and led to the conclusion that the ammonium sulphate was acted upon by the iodic mixture, liberating an additional portion of iodine. Experiments with ammonium sulphate verified the supposition, and the process is, therefore, less accurate in the presence of ammonium salts. In fact, ammonium sulphate in the amounts taken may be completely hydrolyzed in the course of three hours, about one-half of the iodine liberated by the sulphuric acid formed in the hydrolysis being available for estimation under the conditions of the foregoing determinations. When, however, the distillate is collected in a solution of potassium iodide containing sufficient acid to combine with the ammonia volatilized, iodine is liberated in amount equivalent to the entire quantity of sulphates present, and may be titrated with sodium thiosulphate.

The reaction between iodine and ammonia in alkaline solution, and the hydrolysis of ammonium salts, are undergoing further investigation by the writer.

The attempts to obtain a complete reaction by heating the mixture in a pressure bottle showed that the results of this procedure are low, although but slightly deficient, and cannot be used for estimating correctly the amount of aluminium salt in the solution.

The following method can be recommended as one giving constant results which correspond closely with the gravimetric

\* Liquid in Voit flask not clear.

† New standard.

‡ New standard.

determinations and the theoretical amount of alumina in neutral aluminium chloride, sulphate, or alum, little time being necessary for a single determination:

Measure 25<sup>cm<sup>3</sup></sup> of the approximately  $\frac{n}{10}$  solution of the neutral aluminium salt to be analyzed into a Voit flask and to this add a mixture of 10<sup>cm<sup>3</sup></sup> of a solution of neutral potassium iodate (30 grms. to a liter) and 1.0 gm. potassium iodide. Pass a current of hydrogen through the liquid and heat for fifteen to twenty-five minutes, or until the solution is nearly colorless, collecting the iodine liberated in a Drexel flask, about half full of water, in which 3 grms. of potassium iodide is dissolved. Titrate with sodium thiosulphate the iodine in the Drexel flask and that which remains in the solution in the Voit flask, and calculate the amount of alumina, Al<sub>2</sub>O<sub>3</sub>, corresponding to the iodine, 6I, liberated.

The writer wishes to thank Professor F. A. Gooch for friendly assistance during this investigation.

ART. XXIII.—*The Secondary Origin of Certain Granites*;  
by REGINALD A. DALY, Ottawa, Canada.

[Published by permission of the Chief Commissioner for Canada, International Boundary Surveys.]

CONTENTS.

General thesis of the paper.

A. The Sills of the British Columbia (International) Boundary.

The Moyie Sill.

Field Hypothesis.

B. Occurrences in Minnesota.

(a) Pigeon Point.

(b) Governor's Island.

(c) Lake Superior islands and Logan sills.

(d) Cook County, Lake County and other localities.

C. The Sudbury intrusive sheet.

Synthetic discussion.

Magmatic assimilation.

*Summary.*

Asymmetry of the intrusive bodies.

Magmatic Differentiation.

General Application.

*General thesis of the paper.*—Igneous rocks originate in magmas. The discovery of the laws governing the immediate derivation of such rocks from their parent magmas is, therefore, not the final aim of the geologist. He is logically compelled to refer rocks themselves to the yet more fundamental problem of the origin of igneous magmas. Whence come the raw materials of basalt, gabbro, porphyry or granite?

One of the earliest answers to this question has been gradually assuming a systematic statement in the form of the "assimilation theory". This theory holds that some igneous rocks are derived from the compound magmas formed by the local fusion of solid rock in molten rock of a different chemical composition. The process can be imitated in the laboratory furnace, and has certainly operated on many igneous contacts in nature. Yet one of the very latest utterances of one of the world's greatest petrologists reads thus: "The untenability of the 'assimilation' or fusion theory I regard as definitely proved."\* On the other hand, a no less well known authority claims assimilation on a large scale as a necessary stage in the preparation of the Christiania granite.† Brögger and many of his followers hold that the contact phenomena of this granite show that the assimilation theory breaks down even when applied to a most favorable case.

\* "Die Unhaltbarkeit der 'Assimilations'- oder Einschmelzungs-Theorie betrachte ich als endgültig bewiesen."—J. H. L. Vogt, *Die Silikatschmelzungen*, Part II., Christiania, 1904, p. 225.

† F. Loewinson-Lessing, *Comptes Rendus*, 7th Session, International Geological Congress, 1899, p. 369.

This divergence of view is, of course, due to the lack of definite knowledge of the vital conditions controlling the activities of such an intrusive body as the Christiania granite. The study of its accessible contacts can, of itself alone, furnish neither proof nor disproof of the doctrine of wholesale assimilation. Without the aid of other geological data the attempt to solve the problem is like the attempt to produce graphically a complex curve of which but two points are known and fixed. Deep-seated assimilation about any magma chamber can only be finally discussed and evaluated if the complete form of the chamber and the complete composition of its rock-filling are at least tolerably known.

The present paper furnishes a brief discussion of a number of cases where it is believed that magmatic assimilation on a comparatively large scale has taken place. It is believed, further, that the geological conditions in these cases supply elements generally untouched in earlier discussions of the doctrine. The original magma had the composition of a gabbro intruded in the manner of sills; the invaded formations are ancient sandstones, both normal and feldspathic, with associated argillites or schists; the invaded formation, in every case, is more acid than the gabbro; the product of assimilation is always a granite graduating into granophyre. The acid magma is believed, however, to have been derived indirectly from the compound magma of assimilation through a systematic kind of differentiation. The primary cause of the differentiation is referred to the perfect or nearly perfect density stratification of each magmatic chamber.

The result of the investigation has been to confirm the writer's general theoretical conclusions on the subject of assimilation where it was necessarily introduced among the tests of the hypothesis of magmatic stopping\*. Assimilation and differentiation are not antagonistic processes; both of them are involved in the secondary origin of some granites.

#### *A. The Sills of the British Columbia (International) Boundary.*

During the field season of 1904 the writer developed a geological structure section along the 49th parallel of latitude between Port Hill, Idaho, and Gateway, Montana, the two points where the Kootenay River crosses the boundary line between Canada and the United States. It was found that the mountains traversed by the section are for the most part composed of two very thick siliceous sedimentary formations which, in all probability, are of pre-Cambrian age. The two are conformable.

The lower formation has been called the Creston quartzite. It is a remarkably homogeneous, highly indurated light-to medium-gray sandstone, generally thick-platy in structure but

\* This Journal, xv, 269, 1903, and xvi, 107, 1903.



occasionally interrupted by thin intercalations of argillaceous material. The formation is generally composed of nearly pure quartz with a little mica, but some bands are feldspathic to a notable extent. The total thickness of the formation is at least 9900 feet in the vicinity of Port Hill; its base was not directly observed.

Immediately overlying the Creston quartzite is the conformable Kitchener quartzite, composed of about 7400 feet of a highly ferruginous indurated sandstone. This formation is, in the field, distinguished from the Creston quartzite not only by the rusty color of the outcrops but also by a relatively thinner bedding and a greater proportion of micaceous cement, once somewhat argillaceous. Individual beds of the Kitchener quartzite are charged with detrital feldspar, but the formation as a whole is essentially composed of cemented quartz grains.

Dark-colored red, brown, and gray shales with thin intercalations of gray quartzite conformably overlie the Kitchener quartzite. The series, totalling 3200 feet in thickness, has been grouped under the name of the Moyie argillite. This formation appears but twice in the section and then only in comparatively small areas.

This great group of formations, from end to end of the section, has been mountain-built. A few open folds broken by faults appear in the eastern half of the belt, but the deformation has generally been due to the tilting of monoclinical blocks separated by strong normal faults and, more rarely, by thrusts. The tilting ranges though all angles up to verticality, but the average dip is less than forty-five degrees. In consequence of the deformation and subsequent denudation the edges of some 20,000 feet of well-bedded ancient sediment are now exposed for study. There have also come to light a number of thick sills of gabbro intruded at various horizons into the Kitchener quartzite and the upper part of the Creston quartzite. The intrusion and crystallization of the gabbro is believed to have taken place before the upturning of the sedimentaries. The faulting and tilting has repeated the outcrops of certain of the sills. One of the thickest of them has, along with the quartzites, been warped into one of the rare synclinal folds. The thickness of the sills varies from 100 feet to more than 2500 feet.

The main mass of each sill was uniformly found to consist of a hornblende gabbro with essential green (primary) hornblende and plagioclase (labradorite to anorthite, the latter in the cores of occasionally zoned feldspars). Accessory quartz, often in considerable amount, always accompanies the other accessories, which are titanite, titaniferous magnetite, and apatite with often a little biotite and sometimes a little orthoclase in addition. Epidote and chlorite are the principal secondary

minerals. The structure of the rock is typically hypidiomorphic-granular.

Already in those sills that range from 400 to 500 feet in thickness, the gabbro is acidified near its upper contact. The change from the normal composition is seen in the great increase of biotite, orthoclase, microperthite and interstitial quartz.

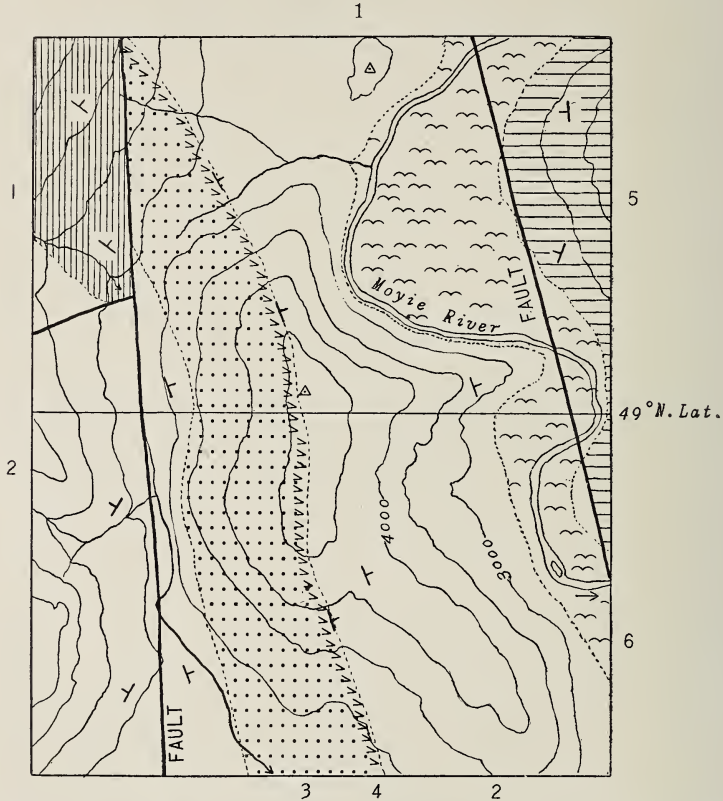

FIG. 1. Map of Moyie Sill, taken from plane-table sheet of the International Boundary Commission. 1. Moyie argillite. 2. Kitchener quartzite. 3. Hornblende gabbro sill. 4. Acidified (granite) zone of sill. 5. Creston quartzite. 6. Alluvium. Conventional sign for strike and dip. Scale: one inch = about one mile.

Biotite and quartz then assume the proportions of essential minerals. The quartz is characteristically in poikilitic relation to all the other constituents except orthoclase and microperthite, with which it is in true micrographic intergrowth. From this micropegmatite-bearing phase of the intrusive there is a gradual transition to the normal gabbro which thus composes the lower three-fourths or four-fifths of the sill.

*The Moyie Sill.*—The acidification of the upper zone of the gabbro being generally in a direct ratio to the strength of the sill, the phenomenon is specially marked in the greatest of all the intrusions. On account of its importance both in size and character, this rock-body is called the “Moyie Sill,” the name referring to its situation on the Moyie River. A map and section of this sill are given in figs. 1 and 2, which illustrate one of the fault-blocks so characteristic of this part of the Boundary belt.\* The sill is rather more than 2500 feet in thickness. It follows the bedding of the Kitchener quartzite, which here dips about sixty degrees to the eastward. The intrusive mass is seen to be cut off at its northern end by a master-fault which has dropped the Moyie argillite down into contact with the

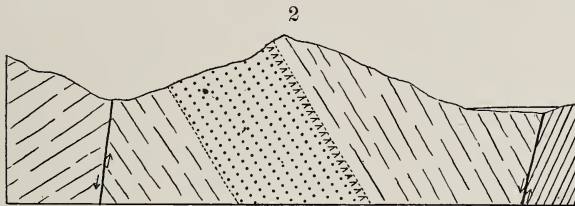

FIG. 2. Section of Moyie Sill, along line of the International Boundary.

gabbro. This faulting is believed to have occurred after the sill-intrusion. There is a complete lack of contact metamorphism in the argillite where it adjoins the gabbro.

Since the Moyie sill, throughout the six miles of linear outcrop studied, is in intrusive contact with the Kitchener quartzite alone, the other sedimentary formations need not here be described in detail. The Kitchener quartzite is, on the whole, a homogeneous terrane. On a fresh fracture the rock is seen to be a fine-grained, vitreous, light to darkish gray, well-bedded but tough, metamorphic sandstone, splitting with some readiness along the darker colored layers. The rusty color of the joint-surfaces and bedding planes is due to the leaching out and subsequent deposition of the iron contained in the pyrite, magnetite, etc., disseminated through the rock.

Under the microscope the rock is always seen to be essentially a fine-grained aggregate of interlocking quartz grains, seldom showing any direct traces of their detrital origin. The quartz mosaic is, in every thin section, shot through with abundant crystals of biotite which is often developed in phenocryst-like individuals occasionally as much as one centimeter in diameter. Sericitic muscovite is seldom absent as an essential, and sometimes rivals the biotite in abundance. Only

\* All the line-drawings used in illustration of this paper have been made for the most part by the aid of a typewriter, provided with a few special keys. The machine permits of a great saving of time in the preparation of the manuscript drawings. Cf. this Journal, vol. xix, 1905, p. 227.

rarely is feldspar essential; in one slide it seems to compose ten to fifteen per cent of the rock. So far as observed, the feldspar of the staple quartzite is orthoclase. No sodiferous mineral has been certainly determined in the rock. Epidote, zoisite, titanite, magnetite, leucoxene, pyrite and zircon, besides chlorite, secondary after biotite, are the other, always subordinate, constituents.

In marked contrast to the normal quartzite is the rock collected at a point thirty feet from the upper contact of the Moyie sill. It is a very hard, vitreous, massive, light bluish gray quartzite carrying much feldspar. The whole rock seems to have been recrystallized. The granular-mosaic structure has been largely replaced by poikilitic and micrographic structures. Quartz is thus either regularly intergrown with feldspar or else encloses non-oriented individuals of the same mineral. The feldspar proved to be orthoclase, albite and microperthite, named in the order of their relative abundance. Biotite and sericitic muscovite are, as usual, in considerable amount. A little magnetite and a few minute crystals of anatase are the subordinate minerals. The characters of this contact phase point to the thorough metamorphism and notable feldspathization of the quartzite in the external contact zone of the gabbro.

The main mass of the sill-rock has the composition noted above as found in the sills generally. The grain is here medium to coarse, the structure hypidiomorphic-granular.

At the lower contact the grain of the gabbro is somewhat finer than in the interior of the sill, but the rock is still medium-grained and never compact. At the same time, interstitial and poikilitic quartz, along with biotite, orthoclase and microperthitic feldspar, are increased in amount. There is thus some acidification of the sill at its lower contact, though the rock is still gabbroid in macroscopic appearance and has hornblende and plagioclase (andesine to labradorite) as the chief constituents. Acidification of this order is visible for at least 200 feet from the lower contact. The intrusive rock is yet more abundantly charged with quartz, biotite and alkaline feldspars in the vicinity of the occasional xenoliths torn from the invaded quartzites.

The conditions are different at the upper contact. They may be readily studied on the wagon-road that threads the floor of the western meridional valley, shown in fig. 1. From the upper contact inward for a perpendicular distance of about 150 feet the intrusive is a highly siliceous rock, the mineralogical composition of which is shown in Table I and Table II. The structure of this rock varies irregularly, even in the same slide, from the hypidiomorphic granular of granite to the structure of granophyre or micropegmatite.

TABLE I.

Mineralogical composition of Rocks showing secondary derivation of Granite. (Essential minerals noted in italics.)

I. MOYIE SILL.

Gabbro.	Intermediate rock.	Granophyre-granite.
<i>Hornblende</i>	<i>Hornblende</i>	<i>Biotite</i>
<i>Labradorite</i>	<i>Biotite</i>	<i>Soda orthoclase</i>
Quartz	<i>Andesine</i>	<i>Microperthite</i>
Titanite	Quartz	<i>Micropegmatite</i>
Biotite	Chlorite	Quartz
Apatite	Titanite	Andesine
	Titanif. magnetite	Muscovite
	Apatite	Titanif. magnetite
		Apatite
		Calcite, epidote, kaolin

Country rocks: highly acid mica-bearing quartzite, sometimes slightly feldspathic, containing quartz, biotite and muscovite (sericite) as principal constituents, with orthoclase, epidote, titanite, magnetite, pyrite, zoisite, chlorite, leucoxene and zircon as subordinate minerals. Occasionally a thin layer or parting of more argillaceous composition.

II. PIGEON POINT.

Gabbro.	Intermediate rock.	Granophyre-granite.
<i>Olivine</i>	<i>Hornblende</i>	<i>Anorthoclase</i>
<i>Diallagic augite</i>	<i>Anorthoclase</i>	<i>Oligoclase</i>
<i>Basic labradorite</i>	<i>Plagioclase</i>	Quartz
Apatite	Quartz	<i>Micropegmatite</i>
Titanif. magnetite	Micropegmatite	<i>Chlorite</i>
	Chlorite	Augite (occasional)
	Magnetite	Muscovite
	Apatite	Rutile
	Rutile	Leucoxene
		Hematite
		Apatite

Country rocks: feldspathic quartzite and slate, containing quartz, orthoclase, plagioclase, chlorite, green mica, biotite, magnetite, leucoxene. Feldspar sometimes 75 per cent of the quartzite.

III. SUDBURY DISTRICT.

Norite.	Intermediate rock.	Granophyre-granite.
<i>Hypersthene</i>	<i>Hornblende</i> or	<i>Biotite</i>
<i>Augite</i>	<i>Hypersthene</i>	<i>Orthoclase</i>
<i>Bytownite</i>	<i>Biotite</i>	<i>Micropegmatite</i>
Quartz	<i>Oligoclase-andesine</i>	<i>Microperthite</i>
Biotite	<i>Orthoclase</i>	<i>Microcline</i>
Hornblende	<i>Microperthite</i>	<i>Oligoclase</i>
Apatite	Quartz	Quartz
Magnetite	Epidote	Epidote
Sulphides	Apatite	Ilmenite
	Magnetite	Titanite

Country-rocks: sandstones, graywackes, slates, conglomerates, greenstones, volcanic tuffs and granitoid gneiss.

TABLE II.

Showing the weight percentages of minerals as determined by the Rosiwal method.\*

	1.	2.	3.	4.	5.	6.	7.
Hornblende .....	58·7	54·8	42·9	49·4	---	---	---
Biotite .....	·9	---	6·6	22·0	8·9	22·0	15·2
Labradorite, Ab <sub>1</sub> An <sub>1</sub> -Ab <sub>1</sub> An <sub>2</sub> } .....	34·8	25·6	---	---	---	---	---
Andesine, Ab <sub>4</sub> An <sub>3</sub> .....	---	---	18·5	16·5	---	---	---
Oligoclase, Ab <sub>2</sub> An <sub>1</sub> .....	---	---	---	---	1·5	1·5	1·0
Soda-bearing ortho- clase } .....	---	---	5·5	---	24·9	29·1	32·5
Microperthite .....	---	---	---	---	---	---	3·9
Quartz .....	4·0	6·3	22·8	11·7	57·1	46·0	41·6
Muscovite .....	---	---	---	---	3·2	---	4·6
Apatite .....	·2	---	---	·3	---	·5	·2
Titanite .....	1·4	2·0	3·7	---	---	---	---
Magnetite .....	---	·3	---	---	1·9	·5	1·0
Chlorite .....	---	11·0	---	---	---	---	---
Calcite .....	---	---	---	---	2·5	·4	---

Total is 100 in each case.

1. Normal unacidified gabbro from sill about eleven miles east of the Moyie sill.

Nos. 2 to 7 inclusive are types from the Moyie sill, specimens taken thus :

2. Thirty feet from lower contact.
3. Two hundred feet from lower contact.
4. Two hundred feet from upper contact.
5. Fifty feet from upper contact.
6. Forty feet from upper contact.
7. Fifteen feet from upper contact.

Table II was constructed by the use of the Rosiwal method for the determination of the relative quantities of the different constituents. The values are only approximate, owing to the difficulties of exact measurement and identification of the mineral grains. No account was taken of the sometimes abundant grains of epidote, occasional grains of calcite (measured in one instance), and often rather abundant scales of kaolin which occur in the slides. These minerals are products of the alteration of the feldspars, that alteration affording another difficulty in using the Rosiwal method for this suite of rocks. The proportions of the micas are probably too high on account of their not being even approximately equidimensional. Though these rocks do not lend themselves to a very satisfactory employment of the method, and though the table cannot be considered as accurate, the strong contrasts between the acid and basic phases of the sill are clearly evident.

\* Verh. Wien. Geol. Reichs-Anst., vol. xxxii, 1898, pp. 143 ff.

Since the compositions of the hornblende, biotite and soda-bearing orthoclase are not known, the chemical analyses cannot be calculated from Table II. Direct chemical analyses of types Nos. 1 and 7 in Table II have been made by Professor Dittrich, of Heidelberg, and are recorded in Table III.

TABLE III.

	1.	2.
SiO <sub>2</sub> .....	51.92%	71.69%
TiO <sub>2</sub> .....	.83	.59
Al <sub>2</sub> O <sub>3</sub> .....	14.13	13.29
Fe <sub>2</sub> O <sub>3</sub> .....	2.97	.83
FeO .....	6.92	4.23
MnO .....	.14	.09
MgO .....	8.22	1.28
CaO .....	11.53	1.66
Na <sub>2</sub> O .....	1.38	2.48
K <sub>2</sub> O .....	.47	2.37
H <sub>2</sub> O (below 110° C.) .....	.10	.14
H <sub>2</sub> O (above 110° C.) .....	1.07	1.31
P <sub>2</sub> O <sub>5</sub> .....	.04	.07
CO <sub>2</sub> .....	.06	.13
	99.78	100.16
Sp. gr. ....	3.000	2.773

1. Normal unacidified gabbro from sill about eleven miles east of the Moyie sill.

2. Acid rock fifteen feet from upper contact of the Moyie sill.

The rock of col. 2 belongs to the granite family. The silica is normal (higher in types of cols. 5 and 6, Table II), but the total of the alkalis is extraordinarily low, namely 4.85 per cent, or .76 per cent lower than the total of the potash and soda in the least alkaline among the twenty-six types of granite analyses selected for Rosenbusch's "Elemente der Gesteinslehre." The comparatively high content of lime is probably to be referred to a not unimportant mixture of lime feldspar and alkaline feldspar in isomorphous relation, as well as to a small amount of secondary epidote.

Col. 1 shows the gabbro to be a normal type in some respects, but the high content of silica and relatively low content of alumina and soda are abnormal for gabbro. These features are partly due to the predominance of hornblende over feldspar and to the presence of free quartz. It can be seen by inspection of cols. 1 and 2, Table II, that the gabbro at the bottom of the Moyie sill would give an analysis very close to that of col. 1, Table III, which represents a good type of the

average gabbro from the many sills of the Boundary belt. A comparison of cols. 2, 4 and 7, Table II, shows that col. 4 corresponds to a rock-type intermediate between the two types actually analyzed. It is planned that a rather complete set of total analyses of the various phases of the Moyie sill will be published in the final report of the Chief Commissioner for Canada on Boundary Surveys.

Partially absorbed inclusions of the quartzite occur also in the upper, granitic zone of the intrusive.

Next to the peculiar granite-granophyre is a hundred-foot (thick) zone of intermediate rock which, with rapid transition,

3

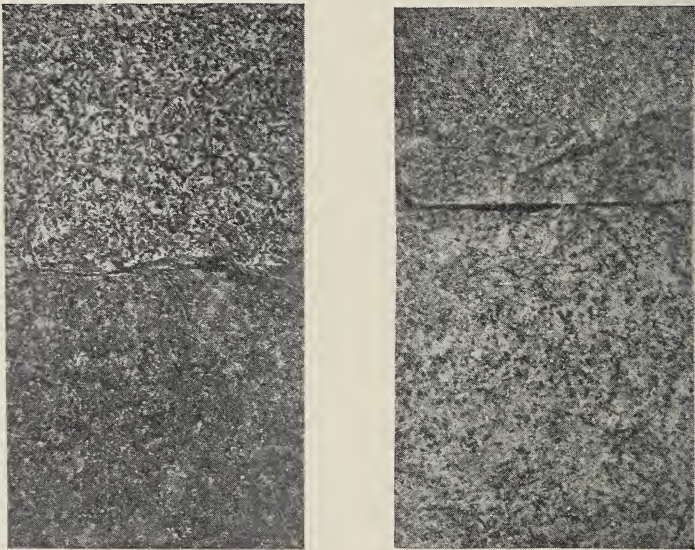

FIG. 3. Photograph of specimens showing contrast of color between a basic and a normal phase of the gabbro of the British Columbia sills and between both of these and two phases of the Moyie Sill granite-granophyre shown on the left.

replaces the acid rock as the section is thus carried inwards through the sill. The mineralogical composition of this intermediate rock is shown in Tables I and II.

The structure is again hypidiomorphic-granular with continual gradations into the granophyric. The grain varies from medium to rather coarse.

The intermediate rock grades imperceptibly into the normal gabbro of the internal part of the great intrusive body.

The variation in mineral composition among the zones of granite, intermediate rock and gabbro are shown in Table II.



The profound macroscopic differences of aspect are imperfectly illustrated in fig. 3, which shows the variation of color-tint. The corresponding variations in the specific gravity of specimens taken in the cross-section of the sill is shown in the following table:

Locality of specimen.	Sp. gr.
15 feet from upper contact .....	2·773
40 " " " " .....	2·784
50 " " " " .....	2·800
Average for granite zone about .....	2·790
200 feet from upper contact .....	3·020
Average for middle of sill about .....	3·025
200 feet from lower contact .....	2·967
30 feet " " " " .....	2·980

A series of determinations showed in addition that the average specific gravity of the normal gabbro in all the sills of the Boundary belt is about 3·020.

Exomorphic contact action was observed at both upper and lower contacts with the Kitchener quartzite. It has taken the form of increasing the already high induration of the sediments with an accompanying special development of biotite at both upper and lower contacts. Though there is evidence of the feldspathization of the quartzite at the upper contact, none has yet been forthcoming for the lower contact, where, nevertheless, feldspar may have been similarly introduced from the magma. Doubtless on account of the chemical nature of the invaded sediments contact metamorphism is not conspicuous in the field, nor is it easy to trace its influence. The writer's impression is that the effects are more manifest, the action having been more intense, at the upper contact than at the lower, but additional field study will be required to test the real truth of that impression.

Apart from the development of exotic feldspar in the quartzite, indications of true pneumatolytic action seem to be lacking at both contacts. Mineral veins, including quartz veins, except occasional stringers of quartz, are conspicuously absent.

*Field Hypothesis.*—The hypothesis adopted in the field to explain these rocks and their relations involved a secondary origin for the granite-granophyre zone at the top of the sill. That zone was thereby interpreted as due to the contact-action of the gabbro intrusion on the adjacent Kitchener quartzite; digestion and assimilation of the sediments both on the main or "molar" contacts and on the peripheries of blocks shattered off from those contacts, was credited with the formation of a new compound magma from which the highly acid and somewhat anomalous granite was derived. The fact that the acid

rock is practically confined to the upper contact-zone was explained by the collection of the products of digestion at the upper contact by gravitative adjustment in the magma. The low density of the locally formed new magma of assimilation would tend to effect its upward diffusion and the consequent cleansing of the heavier gabbro magma from such acid material. The comparatively slight acidification at the lower contact was attributed to the solution of the quartzite in the period immediately preceding the final consolidation of the sill; at that time the viscosity of the magma was too great to allow of the upward diffusion.

A principal test for such a hypothesis is obvious. If it be true, there should be other examples among the great basic sills cutting siliceous sediments. It has already been noted that there is actually such acidification of the other gabbro sills encountered between Port Hill and Gateway, and that in them the acidification is always most marked at the upper contact. Much more striking examples have been described with unusual thoroughness in Minnesota and Ontario. The comparison of these other cases is so important that the best established types will here be sketched and illustrated in some detail. The further discussion of the Moyie sill will be postponed to later pages, in which a synthetic treatment of all the examples will be undertaken.

### B. Occurrences in Minnesota.

(a) The very able and specially detailed memoir of Bayley on the rocks of Pigeon Point contains, doubtless, the most elaborate argument in favor of the secondary origin of some granites. A brief summary of his facts and conclusions may well be given in the works of Bayley's own outline forming the introduction to his paper.

"Pigeon Point is the northeastern extremity of Minnesota. It is one of a series of parallel points extending from Minnesota and Canada eastward into Lake Superior. Its backbone is a great east and west dike-like mass of a gray, coarse-grained rock that has always been called gabbro. This consists of phenocrysts of plagioclase in a diabasic groundmass of the same mineral, olivine and diallage, and consequently, it is a diabase porphyrite. . . .

"The rocks through which the gabbro cuts are evenly bedded slates and indurated sandstones of Animikie age. They dip south-southeast at 15 to 20 degrees, except at a very few places near the contact with other rocks, where they are more or less contorted. . . .

"The most interesting features in the geology of the point relate to the series of rocks usually occurring between the gabbro and the clastic beds. Beginning on the gabbro side the series

comprises in succession coarse-grained red rocks, a fine-grained red rock that is sometimes porphyritic and a well-marked belt of altered quartzites.

“The fine-grained red rock has all the characteristics of an eruptive. It sends dikes into the contiguous bedded rocks, and consists essentially of a hypidiomorphic granular aggregate of plagioclase, anorthoclase and quartz. The quartz and anorthoclase often form micropegmatite, while the plagioclase is in comparatively large grains, some of which have hardly defined idiomorphic outlines. At a few places this red rock is porphyritic, with bipyramidal quartz crystals imbedded in a red granophyric groundmass. The rock is similar to many of the augite-syenites described by Irving as occurring in the Keweenaw series, and is in structure and composition a quartz keratophyre.

“The coarse-grained rocks between the gabbro and the keratophyre are intermediate in character between these two. The variety nearest the gabbro differs but slightly from the basic eruptive. In addition to the gabbro components it contains a little quartz and red feldspar—constituents derived from the keratophyre. As the latter rock is approached, the augite, olivine, and plagioclase disappear, while increased quantities of quartz, red feldspar, and brown hornblende make their appearance, and the rock becomes more and more like the fine-grained red rock. Finally the hornblende disappears and the keratophyre is reached. Since the intermediate rocks occur only between the gabbro and the fine-grained red rock, and since all gradations in composition between the two end members of the series are represented, the coarse-grained red rocks are regarded as contact products formed by the intermingling of the gabbro and the keratophyre magmas.”\*

After describing the compound external zone of contact metamorphism, Bayley continues :

“From the above-mentioned facts it is concluded that the contact belt represents Animikie slates and quartzites that have been altered near their contact with an intrusive rock. The metamorphism of the quartzites has resulted simply in the recrystallization of the quartz and feldspar of the fragmental grains, with the addition, perhaps, of a little orthoclase.

“Since, in several instances, the gabbro is in direct contact with the metamorphosed rocks, while the keratophyre is not to be found in the neighborhood, it is inferred that the former rock and not the latter was the cause of the contact action.”

The significant paragraph follows :

“Inclusions of fragmentals in the gabbro and the keratophyre have alike suffered the same alterations as have taken place in the various members of the contact belt, with this difference, that quartzite inclusions in the basic rock are often surrounded by a

\* W. S. Bayley, Bull. 109, U. S. Geol. Survey, 1893, p. 11.

rim of red rock, identical in all its properties with the keratophyre. This suggests that the keratophyre itself may be of contact origin."

Finally:

"The conclusion reached is that, in all probability, the keratophyre is of contact origin—that is, it was produced by the

4

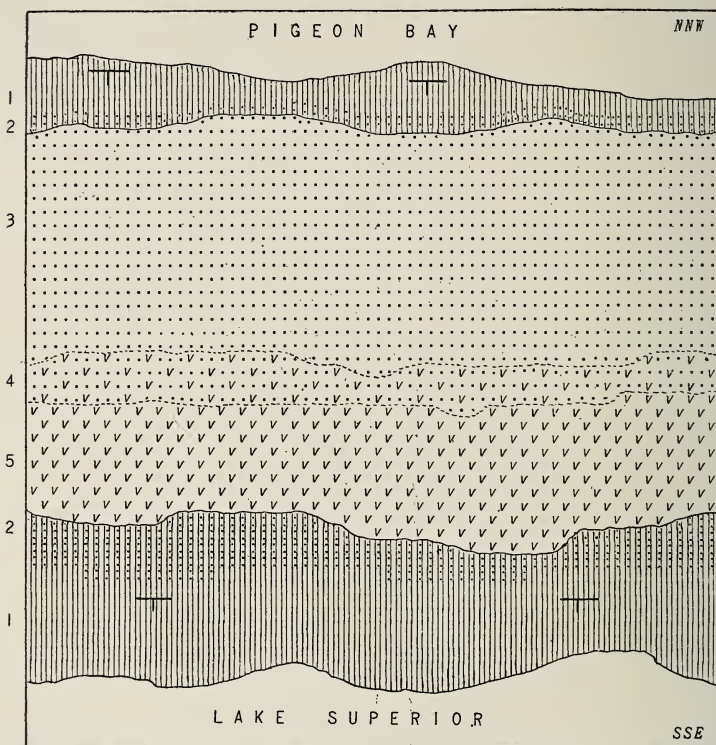

FIG. 4. Diagrammatic map of part of Pigeon Point, Minnesota, showing general relations among the different rock formations; after Bayley.

1. Animikie quartzites and slates. 2. Contact zone in the Animikie sedimentaries. 3. Olivine gabbro. 4. Intermediate rock. 5. Soda granite and keratophyre. Conventional sign for strike and dip. Scale: nine inches = one mile.

fusion of the slates and quartzites of the Animikie through the action upon them of the 'gabbro.' The magma thus formed then acted in all respects like an intrusive magma. It penetrated the surrounding rocks in the form of dikes, and solidified as a soda-granite under certain circumstances, and under others as a quartz-keratophyre."\*

\* *Op. cit.*, p. 12.

The diagrammatic map of fig. 4 generalizes the field relations as expressed in Bayley's maps. There have been omitted from the diagram certain complexities in the maps showing the actual geology. The essential features are thus made all the more evident; at the same time it is believed that this arbitrary treatment of the maps does not introduce error in principles.

A summary of the mineralogical compositions of the gabbro, intermediate rock, granite-keratophyre (granophyre) and invaded sediments is given in Table I. The correlative differences in chemical constitution are noted in Table IV.

TABLE IV.  
Selected Analyses, Bayley on Pigeon Pt.

	A.	B.	C.	D.	E.	F.
SiO <sub>2</sub> .....	49.88%	57.98	72.42	73.85	59.71	70.31
TiO <sub>2</sub> .....	1.19	1.75	.40	.05	tr.	tr.
Al <sub>2</sub> O <sub>3</sub> .....	18.55	13.58	13.04	10.91	18.32	12.81
Fe <sub>2</sub> O <sub>3</sub> .....	2.06	3.11	.68	6.98	8.11	7.26
FeO .....	8.37	8.68	2.49	.89	.85	.88
MnO .....	.09	.13	.09	----	----	----
CaO .....	9.72	2.01	.66	.44	1.05	.60
BaO .....	.02	.04	.15	----	----	----
MgO .....	5.77	2.87	.58	1.52	3.54	2.03
K <sub>2</sub> O .....	.68	3.44	4.97	1.39	3.43	1.90
Na <sub>2</sub> O .....	2.59	3.56	3.44	2.28	1.93	2.19
H <sub>2</sub> O .....	1.04	2.47	1.21	1.88	3.24	2.22
P <sub>2</sub> O <sub>5</sub> .....	.16	.29	.20	----	----	----
	100.12	99.91	100.33	100.19	100.18	100.20
Sp. gr. . . .	2.923- 2.970	circa 2.740	2.620	not given, prob. ca 2.70	not given, prob. ca 2.75	

- A. Olivine diabase; aver. of five specimens . . . p. 37
- B. Intermediate rock . . . . . 63
- C. Red granite; aver. of 7 specimens . . . . . 56
- D. Unaltered quartzites; aver. comp. . . . . 90
- E. Unaltered slate . . . . . 90
- F. Approximation to aver. comp. of sediments 113

The general similarity in the character and spatial arrangement of the rocks at Pigeon Point and on the Moyie River is apparent. The comparison of conditions is obscure only as relates to the structural cross-section. The Moyie intrusive is unquestionably a sill. The underground relations of the Pigeon Point intrusive, for lack of decisive field evidence, have not been fixed beyond the possibility of doubt. Bayley says:

"The most prominent features of these gabbro masses are those of dikes. As has already been mentioned, the larger one [the one referred to in the present paper] in many places presents perpendicular walls both to the north and to the south. It occupies all the highest portions of the point, and these are in a straight line. It has the appearance of an intrusive mass, and is like any one of those forming the numerous points to the north of the international boundary line. It has been regarded as a dike by both Irving and N. H. Winchell. Its contact with the sedimentary rocks is only occasionally to be seen. At several of these contacts the eruptive has the appearance of having escaped from between the dike walls and thrust itself for a short distance between the fragmental beds, or having piled itself up around the dike orifice and overlapped the intruded rocks. . . . At only two places on the north shore do the fragmental rocks appear, and at these places they are far below where they should be were they interbedded with the gabbro, and in neither case is the contact like that of interbedded eruptive and sedimentary rocks."

He concludes that :

"The larger mass of the Pigeon Point gabbro is in the form of a dike, which has broken through its walls at certain places and intruded itself between the strata of the surrounding rocks."\*

In accordance with his view Bayley's cross-sections show vertical contacts among all the igneous rock members and also between sediments and eruptives.

On the other hand, Professor N. H. Winchell states, in a personal letter to the writer :

"All my observations bearing on the relations of the gabbro to the Animikie on Pigeon Point lead to the conclusion that the gabbro is later than the Animikie. But the term gabbro here is made to include those coarse non-ophitic dikes that resemble gabbro and which are also allied to diabase. There are abundant places where this rock is in the form of sills in the Animikie. The great backbone of Pigeon Point, which is the most distinctly gabbroid of the intrusive rocks, is simply a large example of a sill, while, as I interpret the structure, many of the dikes cutting the Animikie are only contemporary offshoots from it."

With Winchell's view there agrees the observation of Bayley that the feldspar phenocrysts of the porphyritic gabbro are sometimes "arranged in rude layers parallel to the dip surfaces of the quartzite. Their longer axes are usually in the direction of the dip of the sedimentary rocks."† This orientation suggests flow-structure parallel to contacts. Professor Bayley has, by letter, restated to the writer his conclusion that "the gabbro was intruded as a boss or huge dike, certainly not

\* *Op. cit.*, pp. 22-23.

† *Op. cit.*, p. 23.

as a sill," but adds the remark that "while the contacts of the quartzites with the red rock and gabbro so far as they were seen are vertical, it does not necessarily follow that they are vertical with depth." He continues: "I have no means of knowing the date of the intrusion. With respect to the tilting (of the quartzites) my guess is that the intrusion was prior to the latest tilting, but later than an earlier tilting lakeward."

The possibility that the Pigeon Point eruptive is either a true sill only locally breaking across the bedding of the sediments or at any rate dips as a whole to the south-southeastward, is further suggested by the analogy of the many undoubted sills of gabbro cutting the southerly to southeasterly dipping Animikie of Minnesota. Some of these sills have likewise zones of soda granite lying between the gabbro and the sediments on the southerly flank of the gabbro. Thus in those cases the sediments dip under the gabbro on the one side of the eruptive body and away from the granite on the other side.

Bayley's full and trenchant argument for the contact origin of the soda granite and granophyre need not be repeated. The independent origin of the acid rock is rendered highly improbable by the occurrences of the intermediate rock lying directly between the gabbro and the sediments without the intervention of the true granite or granophyre.

The efficiency of contact-shattering in aiding the digestion of the slates and quartzites is strikingly manifest in Bayley's descriptions.

"Very close to the red rock appears a belt in which the various rocks are in the most complicated relations imaginable. In the eastern portion of the point this belt is well seen on the southern shore, about one-third of a mile from the end of the point. (See Pl. XVI.) Here the red rock is exposed in low cliffs, and in it are small, sharp slate and quartzite inclusions, into which the red rock penetrates in every direction. The exact line of contact between the red rock and the bedded fragmentals cannot be detected, as they appear to merge gradually into one another, the latter becoming redder and redder as they approach the former, which penetrates them in veins and dikes, and finally includes numerous pieces in such a way as to yield a good eruptive breccia."

"Some of the inclusions are very sharp and but little altered, while others are partially dissolved, and are surrounded by concentric zones, resulting from the action of the red rock upon the material of the inclusion, and the reciprocal effect of the partially dissolved inclusion upon that portion of the red-rock magma immediately contiguous to it. . . . Thus it would seem to be a fact beyond controversy that the red rock is the immediate cause of the alteration noticed in the fragmental rocks and of the brec-

cia observed along its contact with them. If, however, the contact belt is examined very closely, it is found that although the red rock is always accompanied by a zone of this belt, there are localities in which the latter occurs without the presence of the former. . . . The metamorphosing rock seems to be the gabbro. Just as in the case of the contacts with the red rock, the quartzites become mottled as they approach the eruptive, and inclusions of the former in the latter are so frequent that there appears to be a gradual transition between the two rocks.”\*

Similar shatter-breccias are described at the northern contact. The metamorphism of the inclusions is there the same in kind as on the southern contact but is less intense.†

(*b*) A significant discovery was made at a mining prospect on Governor’s Island just south of Pigeon Point. The shaft started in hardened slate at the surface, then struck red quartzite and finally red granite where the sinking was discontinued. In this case there is no question that the sediments overlie the granite in a relation similar to that involved in the sill theory of the Pigeon Point intrusive.‡

(*c*) Parallels to the Pigeon Point case have also been found on Spar, Jarvis and Victoria Islands.§ Lawson has described other examples among the Logan sills of Lake Superior, and says that the sills are repeated by step-faults gently tilting the sills to the southeast at the maximum angle of five degrees.||

(*d*) Grant describes the great gabbro area of Cook County, Minnesota, as a laccolith in the gently dipping Animikie quartzites, slates and graywackes. He maps soda granites passing into alkaline quartz porphyries on the southern flank of the gabbro or in it. This latter occurrence is possibly to be related to the occasional horizontal dips of the Animikie.¶

N. H. Winchell maps a broad band of the red granite to the southward of the huge gabbro mass of Lake County. He states that the southern limit of the gabbro forms the northern limit of the red granite, but that there are numerous places where these rocks are intricately interbedded and in some instances isolated areas of the red rock are surrounded by gabbro.\*\* The official atlas of the Minnesota Geological Survey indicates still other large-scale examples of the same or similar close relations of gabbro and red granite—notably those mapped in vol. vi, plates 68, 69, 84, 85 and 87.

\* Op. cit., pp. 28–29.

† Op. cit., p. 81.

‡ Final Report, Geol. Surv. of Minnesota, vol. iv, 1899, p. 516, and vol. v, 900, p. 799.

§ Bayley, op. cit., p. 30; cf. E. D. Ingall, Ann. Rep. Geol. Surv. Canada, 1888, Pt. H, pp. 45 and 49.

|| Bull. 8, Geol. Surv. Minnesota, 1893, pp. 30–33–42–44.

¶ Final Rep. Minn. Geol. Surv., vol. iv, 1899, pp. 323 and 326.

\*\* Ibid., pp. 296–7.



C. The Sudbury Intrusive Sheet.

A still more remarkable parallel to the conditions of the Moyie sill has been rather fully described by Barlow and Coleman, following the earlier work of Walker in their respective memoirs on the geology of the Sudbury District, Ontario. In the scale of the various related phenomena, in the wonderfully systematic arrangement of the different rock-formations, and in the occurrence of valuable ore-bodies directly and geneti-

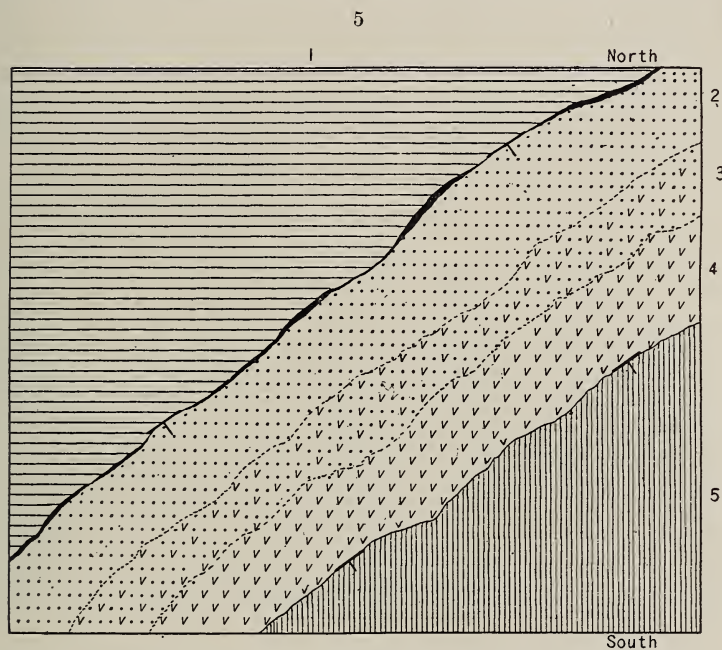

FIG. 5. Diagrammatic map of part of the Northern Nickel Range, Sudbury District, Ontario; after Coleman.

1. Granitoid gneiss, greenstones and graywackes. 2. Norite. 3. Intermediate rock, transitional between norite and micropegmatite. 4. Micropegmatite. 5. Slates, sandstones and volcanic tuffs. (The position of the sulphide ores shown by heavy black line.) Conventional sign for strike and dip. Scale: one inch = two miles.

cally associated with the intrusive, the Sudbury District example stands unique in petrographical records.

The latest reports of Barlow and Coleman agree in the conclusion that the famous nickel-bearing eruptive has the form of an enormous intrusive sill of a composition exactly analogous to that of the Moyie sill excepting as regards the development of the valuable sulphides. It is "a vast sheet of eruptive rock having a basin shape; a sheet nearly 40 miles long

and 17 miles wide, and probably a mile and half to two miles thick on the average, if the (average centripetal) dip (of the sheet) is 45 degrees.”\*

This great sheet cuts sediments and schists referred to the Laurentian and Upper Huronian. Their general field relations are summarized in the diagrammatic map of fig. 5, drawn from a part of Coleman’s official map of the “Northern Nickel Range.” Again the gabbroid rock (norite) is seen to be concentrated on the lower contact of the sheet, the acid rock, micropegmatite or granophyre, graduating into true granite, on its upper contact, while between the two is a zone of intermediate rock. On the “Southern Nickel Range” across the spoon-shaped basin, Barlow has determined the same arrangement of acid, intermediate and basic zones in the sheet, which there, however, agreeably with the basin theory of structure, has a northerly dip; so that in this case, the norite occurs on the south side of the sheet, the granite-granophyre zone on its northern side. On the basin theory of the structure, the volume of the granite-granophyre in this sheet is to be measured by hundreds of cubic miles.

All around the basin the nickel ores form a more or less continuous zone at the lower contact of the norite. The sulphides are also to be found in especial abundance as segregations in apophysal offshoots of the norite where the basic magma penetrated fissures outside the lower contact of the sheet.

Coleman states that where the band of eruptive (outcrop edge of the sheet) is narrow, there is less change in the rock in passing from the lower to the upper contact, the most basic norite as well as ore being absent for the most part. He also notes the absence of granophyre or granite in the smaller intrusions of the norite which occasionally appear outside the main basin.†

Eruptive breccias due to the shattering of the invaded formations by the hot magma are found at both upper and lower contacts.‡

Coleman notes that in the northern nickel range the contact metamorphism is more intense next the upper acid zone than next the norite. He explains this as possibly due to the fact that the rocks at the lower contact were already well crystallized before the intrusion took place, while the sediments along the upper contact were then capable of notable minera-

\* A. P. Coleman, Rep. Bureau of Mines, Ontario, 1903, p. 277. Cf. A. E. Barlow, Ann. Rep. Geol. Surv. Canada, vol. xiv, 1904, p. 72; also stereogram accompanying Coleman’s report.

† 1904 report, p. 212, and 1903 report, p. 286.

‡ A. E. Barlow, op. cit., pp. 122, 129 and plates; A. P. Coleman, Rep. Bureau of Mines, Ontario, 1904, p. 213; T. L. Walker, Quart. Jour. Geol. Soc., vol. liii, 1897, p. 54.

logical changes. The metamorphism on the upper contact extends outward for a distance of from 1000 to 1500 feet.

There seems to be a decided lack of pneumatolytic action (other than that due to water vapor) incident to the intrusion.\*

Coleman has concluded that the intrusion of the sheets *antedated* the synclinal warping of the region to which the present basin shape of the sheet is attributed.†

The mineralogical compositions of the norite, intermediate rock and micropegmatite-granite are summarized in Table I. Their chemical compositions are entered in Table V, taken from Walker's paper, page 56. The corresponding specific gravities also show the significant homologies existing between these rocks and those of Pigeon Point and of the Moyie sill. The value of a close study of these tables will appear in the following general comparison of the rocks and of their relations to one another.

TABLE V.

	1.	2.	3.	4.	5.
SiO <sub>2</sub> -----	49·90%	51·52%	64·85%	69·27%	67·76%
TiO <sub>2</sub> -----	1·47	1·39	----	·78	·46
Al <sub>2</sub> O <sub>3</sub> -----	16·32	19·77	11·44	12·56	14·00
Fe <sub>2</sub> O <sub>3</sub> -----	----	·47	2·94	2·89	----
FeO -----	13·54	6·77	6·02	4·51	5·18
MgO -----	6·22	6·49	1·60	·91	1·00
CaO -----	6·58	8·16	3·49	1·44	4·28
Na <sub>2</sub> O -----	1·82	2·66	3·92	3·12	5·22
K <sub>2</sub> O -----	2·25	·70	3·02	3·05	1·19
H <sub>2</sub> O -----	·76	1·68	·78	·76	1·01
P <sub>2</sub> O <sub>5</sub> -----	·17	·10	·24	·06	·19
	-----	-----	-----	-----	-----
Sp. gr. ....	99·03	99·71	98·30	99·35	100·29
	3·026	2·832	2·788	2·724	2·709

1 to 5—"Specimens range from north to south" across the Sudbury intrusive sheet, that is, from near lower contact (No. 1) to near upper contact (No. 5).

### Synthetic Discussion.

*Magmatic Assimilation.*—The secondary origin of granite has long been maintained by N. H. Winchell, who has referred to the Pigeon Point case as, among others, demonstrating the fact.‡ Bayley came to the same belief for the granite and granophyre of the point, but did not extend his argument in detail to cover other occurrences among the Minnesota intrusives. On the other hand, the principle has not been accepted

\* A. E. Barlow, op. cit., p. 129.

† 1903 report, p. 277.

‡ Final Rep. Minn. Geol. Surv., vol. v, 1900, p. 62, etc.

as applying to these localities even by Van Hise, whose rare knowledge of Lake Superior geology must give his opinion exceptional weight.\* Even the latest text-books of geology give most inadequate treatment of the doctrine though it refers to one of the most important problems in the whole field of geology. Doubtless the majority of petrologists are to-day unfavorable to the assimilation theory of granite and its relatives except as it applies to a very limited, in point of volume insignificant, modification of certain magmas at their contacts.

Van Hise's chief argument against the contact origin of the Pigeon Point granite emphasizes the fact that that rock has not the chemical composition either of the sedimentary formation or (as especially shown in the surplus of alkalis and the deficiency of iron in the granophyre-granite) of a direct mixture of gabbro and sediments.† The much quoted argument of Brøgger with reference to the Norwegian granites is based on a similar fact.‡ Many other writers have, on a similar ground, excluded contact assimilation as playing any considerable part in the formation of abyssal or hypabyssal magmas.

In practically every case the opponents of the assimilation theory have treated of the assimilation as essentially a static phenomenon. Each interpretation of field facts has been phrased in terms of magmatic differentiation *versus* magmatic assimilation as explaining the eruptive rocks actually seen on the contacts discussed. Nothing seems more probable, however, than that such rocks are often to be referred to the compound process of assimilation accompanied and followed by magmatic differentiation. The chemical composition of an intrusive rock at a contact of magmatic assimilation is thus not simply the direct product of digestion. It is the net result of rearrangements brought about in the compound magma of assimilation. In the magma, intrusion currents, convection currents and the currents set up by the sinking or rising of xenoliths must take a part in destroying any simple relation between the chemical constitutions of the intrusive and invaded formations. Still more effective may be the laws of differentiation in a magma made heterogeneous by the absorption of foreign material which is itself generally heterogeneous. The formation of eutectic compounds or mixtures, the development of density stratification, and other causes for the chemical and physical resorting of materials in the new magma ought certainly to be regarded as of powerful effect in the same sense.

A second fundamental principle has as a rule been disregarded in the discussions on magmatic assimilation. The *form*

\* Monograph XLVII, U. S. Geol. Surv., 1904, pp. 730-733.

† Op. cit., p. 733.

‡ Die Eruptivgesteine des Kristianiagebietes, Pt. II, 1895, p. 130.

of the intrusive body, and the relation of the accessible points of its contacts to that form as a whole, must be taken into account. If, for example, differentiation of the compound magma has taken place so as to produce within the magma chamber layers of magma of different density, the lightest at the top, the heaviest at the bottom, the actual chemical composition of the resulting rock at any contact will depend directly on the magmatic stratum rather than on the composition of the adjacent country-rocks.

Thirdly, the method of intrusion is of primary significance in the discussion of assimilation in a given instance. There are strong reasons for believing that the subterranean chambers of stocks and batholiths have been opened largely or at least in part through magmatic "stopping," whereby magmas have made their way upward through the invaded formations by engulfing suite after suite of blocks shattered off from those formations by the heat of the intrusives.\* In such a case the destructive action at the molar contact is chiefly physical, and chemical solution is subordinate. Most of the solution takes place in the complete digestion of the sunken blocks and is therefore abyssal rather than marginal. The conditions are peculiarly favorable for the systematic differentiation of the new compound magma. The chemical composition of the intrusive at any contact will thus depend on the constitution of a (possibly well differentiated) magma containing materials won from *all* the invaded formations and not simply materials won from the immediately adjacent country-rock. Brögger's argument derived from the low content of lime in the Christiania granite cutting thick limestones (themselves overlying an enormous thickness of crystalline schists, etc.) is clearly inconclusive until it can be shown that this and the other two factors just noted have not been at work.†

Magmatic stopping has, in all probability, taken place to some extent in the great intrusive body at Pigeon Point. The specific gravity of the gabbro varies from 2.923 to 2.970. Molten at 1400 degrees Cent., its specific gravity, at atmospheric pressure, would be not far from 2.43 to 2.48. The specific gravities of the intermediate rock and granite are respectively 2.740 and 2.620; molten at 1400 degrees Cent., they would, at atmospheric pressure, be about 2.30 and 2.19 respectively. The specific gravity of the invaded sediment varies from 2.70 to about 2.75. Blocks of the quartzite and slate immersed in any of the molten magmas and there assuming the temperature of 1400 degrees Cent., would at the same

\* Cf. R. A. Daly, *The Mechanics of Igneous Intrusion*, this Journal, vol. xv, 1903, p. 269, and vol. xvi, 1903, p. 107.

† Cf. Loewinson-Lessing, *op. cit.*, p. 368.

pressure have specific gravities varying between 2.60 and 2.65. There are good reasons for believing that plutonic pressures would not essentially affect these contrasts of density. Assuming a certain degree of fluidity in the magma (an assumption underlying the whole of this paper and believed to be demonstrated by such facts as the patent ease of diffusion that once reigned in each of the intrusives), it appears that blocks of the sedimentary rocks must sink in the magma, whether acid or basic.\*

The actual shatter-breccias described by Bayley are therefore to be attributed to the last destructive effort of the magma, which, at that time, through cooling, had become too viscous to allow of the sinking of the xenoliths.

A precisely similar argument applies to the Moyie and Sudbury examples (see table of specific gravities and table in this *Journal*, vol. xv, 1903, p. 277). All these igneous bodies, though not intruded by magmatic stoping, yet show that process to have assisted in the production of the granites and granophyres. Whether this process has there been more or less efficacious than molar or marginal assimilation, perhaps cannot be determined.

In all these cases the stoping that did occur must clearly have tended to destroy a simple chemical identity between igneous rock and country-rock at any given contact.

*Summary.*—It will be useful to review the chief field and laboratory observations so far noted as favoring the assimilation theory when applied to the granites and granophyres described in this paper.

1. Bayley's elaborate argument is believed to be valid except as it fails to take differentiation into account. No fact has been noted either by the writer in connection with the Moyie sill or in the descriptions of the other examples which tends to weaken that argument.

2. Belief in the truth of his conclusion is greatly strengthened by the repeated occurrence of essentially the same phenomena in widely separated regions.

*a.* At Pigeon Point, at Sudbury and on the Moyie River there occur intrusive bodies of gabbro passing by gradual transitions (as shown by chemical, mineralogical and specific gravity determinations) into the border phases of granite and granophyre. Both types of rock clearly belong to the same period of intrusion.

*b.* All three igneous bodies are of relatively great thickness, which means that, other things being equal, they possessed relatively great stores of thermal energy.

\* Cf. R. A. Daly, *op. cit.*, 1903, p. 277, etc.

c. In each occurrence the gabbro contains xenoliths of the more acid sedimentary rocks. These blocks are commonly more or less digested and the product of this local solution is always closely allied to, if not equivalent to, the granophyre-granite phase.

d. In each case there is correspondence though not equivalence between the composition of the acid border-phase and the average composition of the invaded formation. This important fact is emphasized in Tables I, II, III, IV and V, in which the silica and alkalies are either directly or inferentially seen to be more or less abundant in the granophyre-granite according to the relative abundance of those oxides in the respective country-rocks.

e. A considerable number of other examples not as yet thoroughly studied have been noted in British Columbia and Minnesota. The conditions are throughout identical or so allied as to favor one explanation common to all the occurrences.

f. The assimilation theory is also supported by certain other facts which have already been mentioned but merit a more detailed discussion such as is attempted in the sequel.

3. The principal objection to the doctrine of assimilation, namely, the objection that chemical analyses disprove any genetic relationship between intrusive and invaded formation at certain accessible contacts, cannot hold, because that objection allows no place for differentiation in the magma made compound by assimilation.

*Asymmetry of the Intrusive Bodies.*—There remains for particular explanation the cardinal fact that all the intrusive bodies are asymmetric. The granophyre-granite is always concentrated on one side of the intrusive, that is, along the upper contact or the side away from which the enclosing sediments dip.

In all the localities the dips of the sedimentaries and of the intrusive sheets are believed to have been flatter at the time of the injection of the magma than those dips now are. It is, indeed, possible that, in every instance, the gabbro sheet lay practically horizontal during the period of cooling and consolidation. In any case the granophyre-granites appears to have always overlain their respective gabbroid associates.

Three possible explanations have offered themselves for this asymmetry. (a) It is conceivable that extensive assimilation occurred only on the upper contacts; or (b) the asymmetry may be due to the density stratification of magma compounded of gabbro and digested sediments; or (c) due to a combination of both those factors.

One or more subordinate suppositions are necessary if the assimilation be credited essentially to the upper contact. On

the one hand, the invaded formations above and below the gabbro might be lithologically so different that the one above was much more subject to contact alteration than the one below. This idea is at once declared irrelevant in the British Columbia and Minnesota cases, where there is certainly no evidence of differences of digestibility.

On the other hand, it is possible that the original gabbro was differently constituted, and thus more energetic in assimilation, along the upper contact than elsewhere. Magmatic water or other strong solvents may thus be conceived to have early concentrated in the upper zone of each sill. In favor of this view would seem at first sight the fact that at Pigeon Point the zone of external metamorphism is reported by Bayley to be much wider on the upper contact than on the lower. (See fig. 4.) The same seems to be true in the Sudbury case, but is explained by Coleman as noted on a previous page. The writer could find no absolutely certain evidence of such differential metamorphism about the Moyie sill, yet considers it as probable.

That the conditions for the complete assimilation of the invaded formations obtained throughout the intrusive bodies is illustrated in the unmistakable digestion of xenoliths found at all depths in the gabbro. As already pointed out, the assimilation here belongs to the period immediately preceding the consolidation of the gabbro. A much greater volume of similar material derived from the interaction of gabbro and sedimentary rock must have been formed from other blocks in the hotter, more fluid, and more energetic magma of the preceding period. There seems to be no possible doubt that most of that material has diffused upward and now forms part of the granophyre-granite zone.

The simplest and most probable cause for that diffusion is, as suggested in the field hypothesis for the Moyie sill, the difference of density between the acid magma of assimilation and the enclosing gabbro.

It is quite possible that the metamorphosing effect of the new magma may have been greater than that of the original pure gabbro. The new magma would presumably carry with it the water derived from the digested sediments which, apparently in every case, are notably more hydrous than the original gabbro magma. The accompanying table shows the proportion of water (or loss on ignition) found in the analyses of the rocks of Pigeon Point.

Rock.	Per cent of water.
Gabbro .....	1.04
Intermediate rock .....	2.47
Red soda granite.....	1.21
Slate .....	3.24
Quartzite (loss on ignition) .....	1.88



So far as such water determinations in the crystallized rock can be considered as indicating a true condition of the magma before solidification, the table implies that the compound magma corresponding to the "intermediate rock" still held the extra water of assimilation up to the moment of crystallization; and, secondly, that the well differentiated magma corresponding to the soda granite had lost about half of the water of assimilation before final solidification. It is, accordingly, quite possible that this extra water which the upper acid zone could not hold in permanent combination, has been responsible for the unusual amount of external metamorphism in the sediments south of the Pigeon Point intrusive. Similar reasoning may apply to the Sudbury example, but the required elaborate chemical study of its more complex terranes has not yet been made.

In favor of this hypothesis is the fact that, so far as known to the writer, differential contact metamorphism of the kind here in discussion has never been described in connection with a sill that does not also show evidence of strong internal assimilation.

Finally, there is no cause yet well determined why water or other solvents should be systematically concentrated from the original magma along the roof of an intrusive sill. Such concentration may, indeed, be the rule, but it has apparently not been announced by any worker among the thousands of basic sills described in geological literature.

The conclusion seems justified that the special intensity of the metamorphism on the upper contact of certain intrusive bodies is probably not due to the special activity of solvents in the original magma along that contact. The explanation seems to lie partly in the different liability of the roof-rocks and floor-rocks to metamorphic change, but yet more in the metamorphic effects of water vapor set free in the digestion of the invaded hydrous sediments. This water vapor may have also assisted in the solvent work of the magma at the main upper contact, and, finally, in increasing the fluidity of that magma.

*Magmatic Differentiation.*—The development of basic, intermediate and acid zones in each of the sills is, thus, believed to have been the result of the density stratification of the compound magma of assimilation. The efficiency of differential density in separating out lighter acid material from the heavier basic, has been ably discussed and affirmed by Loewinson-Lessing.\* It is unnecessary to recapitulate his argument, with which the present writer is in full accord.

\* Op. cit., pp. 344-354.

Loewinson-Lessing points out that when large amounts of foreign rock-material is digested in a magma, there is established a special tendency toward a systematic differentiation of the mixture.\* Liquefaction will then take place when the cooling mixture reaches a certain temperature. The same author also holds that, according to the principles of physical chemistry, a magma becomes actually more fluid as a result of digesting foreign material. Differentiation is thereby facilitated. Vogt's valuable researches tend to corroborate this view.†

The granites and granophyres of the Moyie sill, of the Pigeon Point intrusive, and of the Sudbury sheet are to be regarded as not directly or merely due to the contact solution of sedimentary rocks and schists by gabbro; they are controlled in their final composition by a common process of differentiation supplementary to the gravitative effect. At Pigeon Point the acid rock, whatever its structure and grain, is a rather definite mixture of oxides. This is illustrated in the analyses of granular soda granite, the "quartz keratophyre", and the porphyry of Little Brick Island near Pigeon Point.‡ For lack of sufficient analyses the same statement cannot be made concerning the Moyie sill, but within limits it applies to the huge Sudbury sheet.§

The acid zone may have won some of its soda from the original magma; the gabbro may now hold some of the potash with the silica derived from the micaceous and feldspathic quartzites and other sediments. It is obvious, however, that all the details of the chemical processes engaged in this type of magmatic separation (chemical affinity in magma disturbed by gravitative diffusion currents) cannot be worked out from existing data on the magmatic behavior of silicates.

The intermediate rock at all three localities may be regarded as occupying zones of incomplete differentiation.

Special interest attaches to the occurrence of the nickel ores along the lower contact of the Sudbury sheet. Barlow, Coleman, Vogt and Walker agree that these sulphides are soluble in magmas. The solubility is in inverse proportion to the acidity of those magmas.¶ The fact suggests that the sulphides have been precipitated from the norite which has been acidified by assimilation. The concentration of the ore on the lower contact is again the result of differentiation through contrasts of density, the sulphides settling to the bottom of the sheet. Loewinson-Lessing has already suggested this gen-

\* *Op. cit.*, pp. 375 ff.

† *Op. cit.*, Part 2.

‡ *Bull.* 228, U. S. Geol. Surv., p. 89.

§ See A. P. Coleman, 1904 report, p. 213.

¶ *J. H. L. Vogt, op. cit.*, p. 229.

eral hypothesis to explain the segregation of sulphide-ores, without, however, connecting the concentration with gravitational influence. Coleman has announced the view that the ores have thus settled to the bottom of the sill, but has not connected the action with the digestion of acid rock in the norite.\* The whole array of facts connected with the Sudbury intrusive is so accordant with the double theory of assimilation and differentiation through density stratification, as to single out this particular case as perhaps, of all those noted in the present paper, the most convincing and illuminating.

It is necessary that brief reference be made to an alternative view of all these related phenomena. One may conceive that the granite-granophyre, intermediate rock and gabbroid rock in each of the intrusive sheets may be explained by simple differentiation from an *original* magma through density stratification but without the aid of significant assimilation of the country-rocks. Lack of space forbids that this hypothesis be here discussed at length. The writer believes that the hypothesis is untenable or, at least, is much less adapted to explaining the facts than the hypothesis of assimilation accompanied and followed by differentiation. Most of the facts on which that belief is founded have been already implied or expressly noted.

Among the significant facts are the following :

1. There is a close similarity in composition between the granite-granophyre zone and rims of manifest digestion about xenoliths now surrounded by gabbro. This consanguinity is inexplicable on the theory of mere differentiation within the original magma.

2. The genetic relationship between the granite-granophyre zone and the invaded sediments is further shown by certain special features already described among the structures of the acid rock in the Moyie sill, and of the overlying, metamorphosed quartzite. For example, the development of remarkably poikilitic quartz in the granite-granophyre and in the recrystallized quartzite (the quartz of the latter being largely or wholly indigenous) may be mentioned. This repeated occurrence of a peculiar structure finds no simple explanation on the pure-differentiation theory.

3. In the period of high temperature preceding the viscous period when the visible xenoliths were frozen in the gabbro, thousands or millions of other xenoliths were completely or in part digested in the gabbro magma. The product of their digestion can be found, apparently, in no other place than in the existing acid zone of each intrusive sheet.

\* 1903 report, p. 277.

4. Mere differentiation of an original magma (through density stratification) cannot readily explain the slight but certain excess of silica along the lower contact of the Moyie sill. That degree of acidification is readily understood on the assimilation theory.

5. Along the British Columbia boundary a large number of contemporaneous gabbro sills of practically identical mineralogical and chemical composition have been found. In most of these no true granite-granophyre zone occurs. The composition of these gabbros is essentially equivalent to that of the gabbro in the central part of the Moyie sill; yet, on the pure-differentiation theory we should expect a distinct difference of composition between these other sills and the basic pole of differentiation in the Moyie sill. The assimilation-differentiation theory finds no difficulty in the essential equivalence of composition.

6. The assimilation-differentiation theory demands that a great absolute amount of thermal energy be credited to a sill in which secondary granite has been formed; that sill must always be thick. Other things being equal, granite formed by mere differentiation from an original magma should be found also in sills of less thickness, though here again the absolute thickness must be considerable. True granite with the relations described in this paper has never been found as a continuous zone in any intrusive sheet 500 feet or less in thickness. On the pure-differentiation theory it is difficult to understand why differentiation should afford true granite in a sheet of the strength observed at Pigeon Point, and should not afford a true granite zone in a sheet 400 or 500 feet thick. The assimilation-differentiation theory readily interprets the fact as due to the relatively enormous amount of heat required for the generation of the granite-granophyre zone, namely, an amount of heat characteristic only of thick intrusive sheets.

7. The pure-differentiation theory has to face another difficult question which does not arise if the assimilation-differentiation theory be accepted. Why was differentiation in the original magma postponed to the moment of intrusion? This difficulty is, of course, by no means conclusive against the pure-differentiation theory, but it means one more unavoidable theoretical burden weighting the pure-differentiation theory in a way which renders, by contrast, the assimilation-differentiation theory one of relative simplicity and, by so much, of greater strength.

*General Application.*—In the foregoing discussion the secondary origin of some granites has been deduced from the study of intrusive sills or sheets; but it is evidently by no means necessary that the igneous rock body should have the

sill form. The wider and more important question is immediately at hand—does the assimilation-differentiation theory apply to truly abyssal contacts? Do the granites of stocks and batholiths sometimes originate in a manner similar or analogous to that just outlined for the sills?

The writer has briefly noted general reasons affording affirmative answers to these questions.\*

Gabbro and granophyre are often characteristically associated at various localities in the British Islands as in other parts of the world.† The field relations are there not so simple as in the case of the Moyie sill, for example, but otherwise the recurrence of many common features among all these rock-associations suggests the possibility of extending the assimilation-differentiation theory to all the granophyres. Harker's excellent memoir on the gabbro and granophyre of the Carrock Fell District, England, shows remarkable parallels between his "laccolite" rocks and those of Minnesota and Ontario.‡

At Carrock Fell there is again a commonly occurring transition from the granophyre to true granite, and again the granophyre is a peripheral phase. Still larger bodies of gabbro, digesting acid sediments yet more energetically than in the intrusive sheets, and at still greater depth, would yield a thoroughly granular acid rock as the product of that absorption with the consequent differentiation. This does not imply, of course, that all granites are of this origin, but it is quite possible that most intrusive granites are either of this origin or have been more or less modified through assimilation.

The difficulty of discussing these questions is largely owing to the absence of accessible lower contacts in the average granite body. All the more valuable must be the information derived from intrusive sills. The comparative rarity of such rock-relations as are described in this paper does not at all indicate the exceptional nature of the petrogenic events signalized in the Moyie, Pigeon Point or Sudbury intrusives. It is manifest that extensive assimilation and differentiation can only take place in sills when the sills are thick, well buried, and originally of high temperature. All these conditions apply to each case cited in the present paper. The phenomena described are relatively rare largely because *thick* basic sills cutting acid sediments are comparatively rare.

On the other hand, there are good reasons for believing that a subcrustal gabbroid magma, actually or potentially fluid, is general all around the earth; and secondly, that the overlying solid rocks are, on the average, crystalline schists and sediments

\* This Journal, vol. xv, 1903, p. 269, vol. xvi, 1903, p. 107.

† See A. Geikie, *Ancient Volcanoes of Great Britain*, 1897.

‡ *Quart. Journal Geol. Soc.*, vol. 1, 1894, p. 311 and vol. li, 1895, p. 125.

more acid than gabbro. Through local, though widespread and profound, assimilation of those acid terranes by the gabbro, accompanied and followed by differentiation, the batholithic granites may in large part have been derived.\* True batholiths of gabbro are rare, perhaps because batholithic intrusion is always dependent on assimilation.

The argument necessarily extends still farther. It is not logical to restrict the assimilation-differentiation theory to the granites. The preparation of the magmas from which syenites and diorites, for example, have crystallized, may have been similarly affected by the local assimilation of special rock-formations. The development of some of the anorthosites of the Canadian and Adirondack Archean was possibly conditioned on the digestion of part of the associated crystalline limestones by plutonic magma.

The officers of the Minnesota Geological Survey have shown that the same magma represented in the soda granite and granophyre of Pigeon Point forms both dikes and amygdaloidal surface flows.† The assimilation-differentiation theory is evidently as applicable to lavas as to intrusive bodies. But demonstration of the truth or error of the theory will doubtless be found in the study of intrusive igneous bodies rather than in the study of volcanoes either ancient or modern.

Finally, the fact of "consanguinity" among the igneous rocks of a petrographical province may be due as much to assimilation as to differentiation.

\* Cf. R. A. Daly, *op. cit.*

† N. H. Winchell, *Final Rep. Minn. Geol. Surv.*, vol. 4, 1899, pp. 519-22.

ART. XXIV.—*On Tychite, a New Mineral from Borax Lake, California, and on its Artificial Production and its Relations to Northupite*; by S. L. PENFIELD and G. S. JAMIESON.

*Historical*.—The new mineral to be described in this paper was discovered by the merest chance in 1895, when some minerals from Borax Lake, San Bernardino County, California, were being studied by one of the present writers (Penfield). At the time mentioned, word had been received from Mr. Warren M. Foote of Philadelphia that he had some unknown minerals from the Borax Lake region, and arrangement was made for their examination in the mineralogical laboratory of the Sheffield Scientific School. One of the minerals, which proved to be a new species, consisted of octahedral crystals, averaging about  $3^{\text{mm}}$  in diameter, and concerning it Mr. Foote wrote that it was a carbonate of magnesium and sodium containing chlorine. The material sent for examination consisted of a large number of the octahedral crystals, and from amongst them a small one, which was perfect in form and seemed to be in every way typical of the lot, was selected for the purpose of making a few preliminary tests. It was brought in contact with a drop of nitric acid on a watch glass and dissolved with effervescence; the solution gave the flame test for sodium, a minute drop of it gave the reaction for magnesium with ammonia and sodium phosphate, but a test for chlorine with silver nitrate gave a negative result. Thinking over what else might possibly be present, the idea of a sulphate suggested itself, and a test with barium chloride indicated the presence of the  $\text{SO}_4$  radical. Accordingly, a letter was sent to Mr. Foote informing him that there evidently was some mistake, for the mineral he had sent proved to be a sulphate and not a chloride. This elicited an immediate reply from Mr. Foote, stating that, on the contrary, the mistake was on our part, for he had always obtained the test for chlorine and had repeated the experiment with like results; thereupon the test was repeated by us, and the presence of chlorine was found in one crystal after another. The fact, therefore, was established, that in the material sent there were two minerals crystallizing in octahedrons, one containing the sulphate radical, the other chlorine, and that by chance a crystal of the rarer sulphate happened to be the one first selected for making the initial examination. A preliminary notice of the chlorine compound was published by Mr. Foote,\* who named the mineral *northupite* after Mr. C. H. Northup of San Jose, California,

\* This Journal (3), 1, p. 480, 1895.

who first observed the new mineral and supplied the material for investigation. A complete study of the chemical composition and physical properties of the new compound was subsequently made by Pratt, who found the composition to be  $\text{MgCO}_3 \cdot \text{Na}_2\text{CO}_3 \cdot \text{NaCl}$ , his results being published in this Journal.\*

Being assured of the existence of a second, new, octahedral mineral, associated with the northupite, Mr. Foote generously responded to our request to send to New Haven his entire stock of crystals in order that a search might be made for the missing sulphate. The following simple method of testing was employed, which did not in any way injure the specimens: Some dilute nitric acid containing a little silver nitrate was prepared, and with a broom-straw a minute drop of the liquid was applied to each crystal. Thus, if chlorine was present, a little silver chloride would be formed and the drop of liquid would become milky-white. In testing several hundred crystals in this way, only two were found which did not give the reaction for chlorine. One of these was a small but perfect octahedron, the other a small cluster of octahedrons, of somewhat inferior quality: together they weighed only about 0.10 gram. It was hoped, however, that by sacrificing the specimens for chemical analysis sufficient determinations could be obtained for deriving the formula; but in this we were disappointed, for, unfortunately, the analysis met with an accident before a single determination had been made. We were thus compelled to abandon the hope of determining the composition of the new mineral until other crystals should be found in new lots of the northupite.

Recently our attention was called to the unknown sulphate by observing in the stock of Mr. Lazard Cahn of New York a supply of northupite crystals which he generously loaned to us for examination, but when tested they all proved to be the chlorine compound. Likewise Mr. Warren M. Foote of Philadelphia has been kind enough to send us his entire stock of northupite, consisting of something over four thousand crystals, among which we had the good fortune of finding one small octahedron, weighing but 0.0109 gram. Curiously enough, this was among the last ten crystals which were tested, and was found after hope of obtaining the desired sulphate had practically been given up.

*Artificial production.*—Believing that the unknown sulphate would prove to be closely related to northupite, and knowing that de Schulten† had succeeded in making the latter artificially, it occurred to us that possibly the wished for sulphate

\* This Journal (4), ii, p. 133, 1896; also, iii, p. 75, 1897.

† Bull. Soc. Franc. de Min., vol. xix, p. 164, 1896.



might also be prepared synthetically. Following in general the method of de Schulten, 8 grams of  $\text{Na}_2\text{CO}_3$  and 34 grams of  $\text{Na}_2\text{SO}_4$  were dissolved in  $120^\circ\text{C}$  of water, and to the solution 1.4 grams of  $\text{MgSO}_4$  were added, which immediately produced an amorphoid precipitate, presumably of some basic magnesium carbonate. The mixture, contained in a flask, loosely stoppered to prevent evaporation, was then heated on a steam bath. By using chlorides in the place of sulphates, as described above, de Schulten succeeded in making northupite in a crystallized condition in about seven hours; in our experiment, however, we waited five days, the solution being heated without interruption, before any signs of crystallization appeared. In the meantime we had tried heating a similar mixture in a sealed tube at a high temperature, without definite results, and had practically given up hope of obtaining the desired crystals. It was almost a matter of accident, therefore, that the flask containing the mixture was left standing on the steam bath for so long a time. When the crystallization had once started, however, it apparently proceeded quite rapidly, and the insoluble material in the flask was almost wholly converted into octahedral crystals, very symmetrical in development and remarkably uniform in size, about  $0.15\text{mm}$  in diameter. Having once produced a crop of crystals, we are now able, by "seeding" or adding some of the product already formed to a new experiment, to produce crystals in fifteen hours, though it still seems to take several days to complete the reaction. When examined under the microscope, it was found that each crystal contained minute inclusions, presumably of basic magnesium carbonate, but the inclusions constituted a very small proportion of the total bulk of the material. The crystals were next suspended in acetylene tetrabromide, diluted with benzol, and it was found that they all floated when the specific gravity was 2.594, and on diluting to 2.583 almost all of the material sank. The mean of the two values, 2.588, may therefore be taken as the specific gravity of the mineral. It was found that the lighter crystals, left floating on the heavy solution, were perceptibly richer in inclusions than those which sank at 2.583. The crystals are quite hard and give a gritty sensation when ground in an agate mortar. They scratch calcite and probably, like northupite, have a hardness between 3.5 and 4. The crystals are isotropic when examined in polarized light. Using two surfaces which come together at the apex of an octahedron as a prism, it was possible to determine approximately the index of refraction, but the surfaces of the crystal were not good enough to make the determination accurate beyond the second place of decimals: the value found was 1.510, while  $n_y$  for northupite was 1.514.

An analysis of the purest material, separated by means of the heavy solution, gives the formula  $2\text{MgCO}_3 \cdot 2\text{Na}_2\text{CO}_3 \cdot \text{Na}_2\text{SO}_4$ , the results being as follows :

	I.	II.	Theory.
$\text{SO}_3$ .....	15·08	15·06	15·33
$\text{CO}_2$ .....	33·55	33·45	33·72
$\text{MgO}$ .....	15·83	15·77	15·33
$\text{Na}_2\text{O}$ .....	35·49	35·65	35·62
	<hr/> 99·95	<hr/> 99·93	<hr/> 100·00

The slight discrepancies between the results of the analyses and the theory are probably to be accounted for by the presence in all of the crystals of the minute inclusions mentioned on the previous page.

The finely powdered salt does not dissolve to any extent in hot water, nor does it suffer decomposition. Some powder, boiled with water for a considerable time, then filtered and dried, gave the following results:— $\text{SO}_3$ , found 15·21 per cent, theory 15·33 per cent. The filtrate gave only a slight reaction of a sulphate when tested with barium chloride.

*Name.*—We have named the new and rare sulphate *tychite*, from  $\tau\upsilon\chi\chi\eta$ , meaning luck or chance, a name which it well deserves, when it is considered that out of fully five thousand specimens examined, the very first crystal and one of the ten last crystals tested proved to be the sulphate, and only two other specimens were found, the ones lost in an unsuccessful attempt to make an analysis.

*Comparison of the artificial salt with the natural mineral.*—Without question, the artificial salt is identical with the mineral found at Borax Lake: they both contain the same constituents. They crystallize not only in the same system, but also in octahedrons. They are isotropic, although the last crystal of tychite found showed some slight action on polarized light, which seemed to be confined only to the exterior portions of the crystal, for fragments from the interior were wholly isotropic. The specific gravity of the artificial salt is 2·588, of the crystal examined by Pratt (the analysis of which was lost) 2·456, and of the last crystal found by us 2·30. The last crystal, however, contains numerous inclusions, which undoubtedly account for its low specific gravity. As far as can be recollected, the crystal examined by Pratt was very white and pure, but not equal in transparency to the artificial crystals. Both Pratt's determination, 2·456, and ours of the artificial salt, 2·588, are somewhat higher than the specific gravity of northupite, as might be expected from differences in composition: Pratt found the specific gravity of northupite to be

2380, and de Schulten determined that of the artificial salt as 2377. By using two of the faces which meet at the apex of the octahedron as a prism, we have succeeded in determining the index of refraction of the last crystal found. The surfaces of the octahedron were not very perfect, and had to be covered over for the most part, taking the reflections of the signal from only the tip end of the crystal, and the refraction of light through the same. The value obtained,  $n_v=1.508$ , compares favorably with that of the artificial salt, 1.510, especially when it is taken into consideration that the condition did not favor exact determinations in either case. A further argument for the identity of tychite and the artificial salt, if any is needed, is that at Borax Lake both tychite and northupite occur together, and were formed undoubtedly under similar conditions, while in the laboratory either of these closely related chemical compounds may be made by only varying the conditions of the experiment by using sodium sulphate for the one and sodium chloride for the other.

Of the four specimens of tychite thus far found, three have been very symmetrically developed octahedrons, but small, measuring not over 3<sup>mm</sup> in diameter, and noticeably whiter than the average of the northupites. It is the small size of the crystals which favored the discovery of the new mineral, for in the original preliminary test one of the smallest and whitest specimens was selected, both because of its evident purity, and also with the idea of not using up any more material than was necessary. Those who may happen to have northupite crystals and wish to search for specimens of the new mineral, may look for tychite therefore among the smaller crystals. We are informed in a recent letter from Mr. Northup that the chances of finding additional crystals of tychite, or of the associated minerals, northupite and pirssonite, are too remote to be seriously considered, as the old borax works are now dismantled. Tychite, therefore, promises to be a very rare mineral, unless a new locality for it happens to be discovered. The single crystal which we recently had the good fortune to find, Mr. Foote has generously presented to the Brush Collection of the Sheffield Scientific School, and both for this gift and for the interest he has taken in assisting us in our investigation we take pleasure in expressing our most sincere thanks.

*Comparison of tychite and northupite.*—The two minerals, found so intimately associated with one another and both crystallizing in octahedrons, are chemically closely related, but in order to show the relation it is necessary to double the formula of northupite, as determined by Pratt. The compositions may then be expressed as follows :

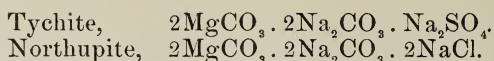

Other physical properties are given below :

	Specific gravity.	Index of refraction, $n_y$ .
Tychite,	2·456 natural.	1·508 natural.
	2·588 artificial.	1·510 artificial.
Northupite,	2·380 natural.	1·514 natural.
	2·377 artificial.	

*Theoretical.*—There seems to be far more interest connected with the present investigation than the mere description of a new species. Although northupite is somewhat slowly soluble in cold water, and is quickly decomposed by boiling water with the separation of magnesium carbonate, tychite is almost insoluble, even when its fine powder is treated with boiling water. Unlike most insoluble substances, however, which precipitate quickly as soon as the constituents necessary for their formation are brought together, northupite and tychite are formed slowly. In de Schulten's experiment, northupite was obtained after seven hours heating, and in ours it took nearly as many days of continued heating to obtain crystals of tychite. It would seem as though the slowness with which these substances are formed might be taken as an indication of their having a complex molecular structure, and that the element of time is necessary for the arrangement of the atoms in a state of equilibrium. Just what the arrangement of the atoms is, we are not able to determine, but the simplest and most symmetrically developed formulas which suggest themselves are the following :

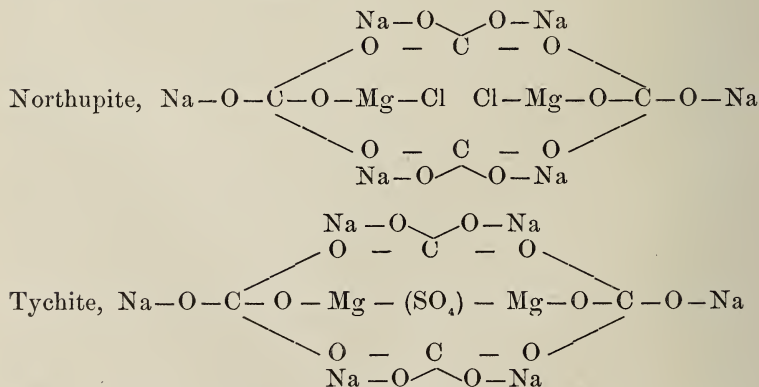

In these formulas the four carbon atoms are united by oxygen in ring formation, which it may be assumed it takes some time to establish, but, when once established, accounts

for the stability of the compounds. It is possible also that the assumed symmetrical arrangement of the atoms in the molecule is the cause of the crystallization of these compounds in the isometric system, for, as a rule, salts of a highly complex nature crystallize in some system other than the isometric. Moreover, if the above formulas are correct, it might be expected that tychite would be more difficultly soluble in water than northupite, for the  $\text{SO}_4$  radical uniting the two magnesium atoms would serve, as we might say, to protect the latter from attack, while the sodium atoms could not be taken away without disturbing the equilibrium of the molecule. Perhaps also the union of the magnesium atoms by the  $\text{SO}_4$  radical in tychite is more difficult to establish than the combination of the two chlorine atoms with magnesium in northupite, which may account for the greater length of time required to make the sulphate compound artificially.

In these compounds, two chlorine atoms in the one and a  $\text{SO}_4$  radical in the other play the same rôle, and are isomorphous with one another in the broader sense of the term, namely, that different constituents may enter into similarly constituted molecules without changing the crystalline form. In simple chemical compounds, it is contrary to all experience that a chloride and a sulphate should have the same crystalline form, or be isomorphous with one another. In the salts under consideration, however, it is assumed that some definite arrangement of the large number of sodium, oxygen, carbon and magnesium atoms, by virtue of *mass effect*,\* determines the crystalline form of the compounds, and that the rôles played by two chlorine atoms in the one and a  $\text{SO}_4$  radical in the other are relatively so unimportant that either of these constituents may enter into the molecule without changing the crystalline form. Whether it is possible to obtain a single crystal containing both the two chlorine atoms and the sulphate radical replacing one another as isomorphous constituents, or to obtain a single crystal with a nucleus of one salt and an external growth, in parallel position, of the other, we are not as yet able to state, but experiments along these lines, to determine to what extent the principles of isomorphism may be applied to so widely different radicals as  $\text{Cl}_2$  and  $\text{SO}_4$  under the influence of mass effect action, will be carried on and form the subject of a later communication. In one experiment, in which the attempt was being made to obtain a product containing both  $\text{Cl}_2$  and the  $\text{SO}_4$  radical, a small crop of octahedral crystals was formed which reacted for neither chlorine nor sulphate. In appearance

\* Compare *mass effect* action as applied to tourmaline (Penfield and Foote, this Journal (4), vii, pp. 122-124); also to the alunite-jarosite group of minerals (Hillebrand and Penfield, this Journal (4), xiv, pp. 216-220).

the crystals were in every respect like those of the artificial northupite and tychite. As seen with the microscope the crystals were full of inclusions, and, in forming, had evidently enclosed an unusually large amount of amorphous magnesium carbonate precipitate. We assumed at once, and correctly, that the compound would prove to be like northupite and tychite, except in having a  $\text{CO}_3$  radical in the place of  $\text{Cl}_2$  and  $\text{SO}_4$ , namely,  $2\text{MgCO}_3 \cdot 2\text{Na}_2\text{CO}_3 \cdot \text{Na}_2\text{CO}_3$ ; see page 222. The analysis, made on a small quantity of the rather impure product, gave almost the theoretical percentage of  $\text{CO}_2$ , but the  $\text{MgO}$  was high and the  $\text{Na}_2\text{O}$  low, which was to be expected. Attempts will be made later to produce this salt in a state of purity, when it will be described more minutely.

Mineralogical Laboratory of the  
Sheffield Scientific School of Yale University,  
New Haven, Conn., July, 1905.

ART. XXV.—*A Modification of Victor Meyer's Apparatus for the Determination of Vapor-Densities*; by B. J. HARRINGTON.

THE ingenious apparatus devised by the late Professor Victor Meyer for the determination of vapor-densities has been in use for many years and has proved of great value for the purpose for which it was intended. It, however, has certain imperfections, being awkward on account of its height and very liable to be broken, especially in the hands of inexperienced workers. Two modified forms of the apparatus have been devised by the writer and have proved so useful in our own laboratories that it has been deemed worth while to publish a description of them. In both cases an attempt was made to simplify the apparatus and make it more convenient and rapid to work with.

The first form tried is that shown as fig. I in the accompanying illustration. It will be observed that the receptacle  $dd$  is horizontal instead of vertical and that the long stem of Meyer's apparatus is bent upon itself a number of times; the apparatus accordingly occupying but little space. Instead of the long outer tube or jacket ordinarily employed, a box made of tinned iron or copper is used.

In making an actual determination the space around the glass at  $m$  and  $k$  (fig. II) is packed with a little asbestos, and it has been found advantageous to lay a piece of asbestos card on the cover of the box.

The weighed material in the ordinary stoppered tube or bulb is dropped in at  $e$  (fig. I) and as it has not far to fall there is no need of the usual cushion of asbestos or sand. As soon as one operation is completed the vapour is quickly swept out of the apparatus by connecting the tube  $ab$  (fig. I) with the vacuum-pump, the water in the box  $ff$  (fig. II) being kept continuously boiling. In this way one operation quickly succeeds another, and it has been found that students can make two or three determinations in the time required for one with the ordinary apparatus.

The second form experimented with is shown at III. In this the receptacle  $dd$  of I is placed vertically, as it was thought that the vapor would be less likely to be carried into the delivery tube than if the horizontal position were adopted. The tube  $e$  is somewhat longer than in the first form (I) but the curve at the bottom checks the velocity of the little tube containing the liquid and no asbestos is required at the bottom

of *dd*. Like No. I, this form is much more easily dried out than the ordinary apparatus. The metal box for No. III. is

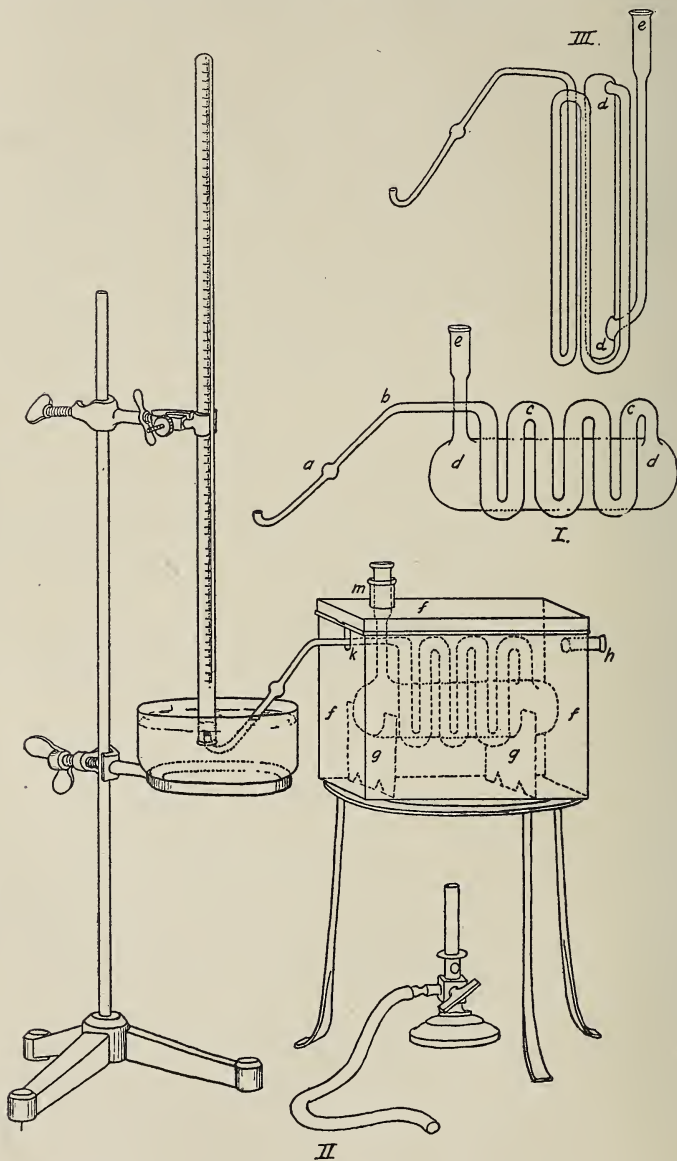

not shown in the drawing, but its construction can be readily understood. With both forms of apparatus *e* was closed with



an ordinary cork, a correction being made for the small quantity of air displaced by the cork, but of course one of the improved appliances for introducing the liquid could be employed. So far the apparatus has been tried only for bodies with comparatively low boiling points, but it could no doubt be adapted for use with liquids with higher boiling points.

The following table gives a series of molecular weight determinations kindly made for me by Mr. Douglas McIntosh, D.Sc., of this university, with the different forms of apparatus, and gives an idea of the results which may be expected. Apparatus No. II. has, on the whole, been found to give more concordant results than No. I, but the latter is simpler and less likely to be broken than the former and in either case the figures obtained are sufficiently accurate for the purpose. They were obtained by working very rapidly and with no special precautions, and cannot therefore be fairly compared with those given by Victor Meyer's apparatus in the last column; for in the case of the latter Dr. McIntosh states that he took every precaution in order to ensure the most accurate results possible.

MOLECULAR WEIGHT DETERMINATIONS MADE BY MR. DOUGLAS  
McINTOSH, D.Sc. (Air =  $2 \times 14.44$ )

	Modified Apparatus No. I.	Modified Apparatus No. II.	Meyer's Apparatus.
Methyl	35.0		
Alcohol	36.0		
CH <sub>3</sub> OH	36.9	32.9	
(32)	36.5	33.4	
	34.0	33.5	31.91
	36.9	33.1	31.94
	34.7		
	34.8		
	37.2		
	<hr/>		
Mean	35.8	Mean 33.2	Mean 31.93
Methyl	46.0		
Alcohol	43.1	44.1	
C <sub>2</sub> H <sub>5</sub> OH	45.0	44.7	46.70
(46)	44.5	44.3	46.10
	43.6		
	42.3		
	<hr/>		
Mean	44.1	Mean 44.4	Mean 46.40

228 *Harrington—Modification of Victor Meyer's Apparatus.*

	Modified Apparatus No. I.	Modified Apparatus No. II.	Meyer's Apparatus.
Acetone	59.4		
$\text{CH}_3 > \text{CO}$	57.2		
$\text{CH}_3$	59.2	58.9	
(5S)	58.0	59.0	57.90
	59.0	58.5	57.80
	59.1		
	<hr/>	<hr/>	<hr/>
Mean	58.6	Mean 58.8	Mean 57.85
Ether	76.1		
$(\text{C}_2\text{H}_5)_2\text{O}$	80.0		
(74)	82.6	77.7	
	74.9	75.0	75.70
	82.6	77.1	76.90
	76.1	76.2	
	<hr/>	<hr/>	<hr/>
Mean	78.7	Mean 76.5	Mean 76.30
Benzol	77.3		
$(\text{C}_6\text{H}_6)$	73.3	81.2	
(78)	80.2	80.8	79.00
	81.1	80.4	79.20
	81.7	79.7	
	<hr/>	<hr/>	<hr/>
Mean	78.7	Mean 80.5	Mean 79.10
Chloroform	134.9		
$\text{CHCl}_3$	131.5		
(119.5)	122.6		
	126.3	124.2	
	136.8	124.9	
	125.5	122.8	123.20
	125.8	126.2	123.00
	<hr/>	<hr/>	<hr/>
Mean	129.1	Mean 124.5	Mean 123.10

McGill University, May, 1905.

ART. XXVI.—*A New Lower Tertiary Fauna from Chappaquiddick Island, Martha's Vineyard*;\* by THOMAS C. BROWN. (With Plate VIII.)

CHAPPAQUIDDICK Island lies at the eastern end of Martha's Vineyard and owing to the shifting nature of the sands and varying tidal currents, it is at times connected with that island, but it is for the greater part of the time completely separated from it. Dr. Arthur Hollick has made a very careful study of the structure of this island and collections of the molluses and plants found fossil upon it.\* The fossil plants have been very fully described by him in the Bulletin of the New York Botanical Garden, vol. ii, No. 7. The mollusc material has not been described and its horizon was provisionally set as Cretacic by Dr. Hollick because of the similar lithological character of this material with other deposits on Martha's Vineyard containing undoubted Cretacic fossils.

A careful study of the fossils has shown that this material is not Cretacic but Eocene in age and that it contains a new and peculiar fauna, a fauna which differs considerably from that of the Eocene deposits of the southern Atlantic slope.

In describing the deposits from which these molluscan remains were obtained Dr. Hollick says: ". . . the Island may be said to be composed of reassorted drift. . . . These hills in general may be described as kame-like, both in appearance and in composition. They are rounded accumulations of sand, gravel and cobble stones, with some bowlders, and were evidently formed by water action. In many places the sand and gravel is cemented together by limonite, forming hard lenses and strata, and ferruginous concretions and shaly fragments are abundantly represented."†

In his geological studies of Martha's Vineyard and surrounding islands Professor Shaler recognizes these ferruginous concretions and concerning them he says: "On the Island of Chappaquiddick and in the region near Edgartown, occasional fragments of a ferruginous sandstone are found which closely resemble in their general character the materials containing the Cretaceous fossils, but as they offer no organic remains I hesitate to consider them of that age."‡

Dr. Hollick considered these concretions as lithologically identical with those containing Cretacic molluscs and plants and set out to make a collection of organic remains that would

\* The investigations on which this paper is based were carried on in the Paleontological Laboratory of Columbia University and the types of these species are in the university collection.

† Bull. N. Y. Botanical Garden, vol. ii, No. 7, p. 399.

‡ N. S. Shaler, 7th Ann. Report U. S. G. S., p. 326.

substantiate the point. "A systematic exploration of all exposures was therefore prosecuted; hundreds of the concretions and shaly fragments were broken open and critically examined and the result was a collection, not only of molluscs but also of plant remains, a few of which were found sufficiently well preserved for identification."\*

Upon his return Dr. Hollick submitted the molluscs to Professor R. P. Whitfield of the American Museum of Natural History for a hasty examination, and concerning them Professor Whitfield spoke thus: "I have examined the fossils you sent the other day but I cannot satisfy myself as to their age. They consist of a *Modiola*, which apparently does not differ from our common *M. plicatula*, of the harbor here; an *Anomia* which might pass for *A. gigantaria* of the lower greensand marls of New Jersey, if it were not for the *Modiola*; also a single imperfect internal cast of a small (young?) *Pectunculus* not enough of it to tell the species, and a small bivalve of which I cannot yet determine the genus. These are the only shells I can recognize, and from their evidence I should think the rocks could hardly prove to be Cretaceous."†

These fossils were also submitted to Professor Grabau of Columbia University for examination. "Mr. Grabau is of the opinion that they may represent a new fauna, of more recent age than the Cretaceous, and this is quite consistent with the conditions under which they occur, so far to the south of any recognized Cretaceous outcrop. The character of the matrix also, with a single exception, is notably different from that in which undoubted Cretaceous molluscs have been found elsewhere, being a micaceous sandstone instead of a hardened clay or greensand."‡

A careful study and detailed comparison of these fossils with descriptions, figures, and specimens of the Cretacic and Eocene species shows that these fossils represent a new fauna of Eocene age. This fauna, however, differs widely from that of the Eocene deposits of the South Atlantic coast and seems to be more closely allied in general to the Eocene of England. Some of the specimens are very well preserved, while others are only represented by external and internal molds. Many of these molds are of such a nature and so well preserved that a wax impression can easily be taken and the characters of the fossil observed and compared. The following descriptions and comparisons include the best preserved and most typical specimens. Some of these are not perfect enough to be described as new species, but most of them can be generically placed.

\* Bull. New York Botanical Garden, vol. ii, No. 7, pp. 399-400.

† Bull. N. Y. Botanical Garden, vol. ii, No. 7, p. 400.

‡ Ibid., p. 401.

*Modiola vineyardensis* sp. n. Pl. I, fig. 1.

Shell strongly ventricose, with a very prominent, almost angular umbonal ridge extending from the beak to the ventral margin. Shell distinctly concave anterior to this ridge; posterior to this ridge it becomes flattened toward the posterior margin; anterior end extremely short barely extending beyond the beak; posterior margin angulate, front margin nearly straight only a slight emargination occurring, basal end rounded; the portion of the margin from the end of the hinge line to near the point of angulation, and from beyond the point of angulation to the ventral margin, are almost straight lines. Surface with pronounced raised radii, flattened at the top and separated by spaces equal to or slightly wider than the radii; the radii are very fine and crowded on the anterior portion of the shell, much coarser on the median and posterior region, and distinct from the beak to the margin. They increase in size progressively from the dorsal to the ventral portion of the shell, with a corresponding increase in the width of the interspaces. They increase in number by intercalation as well as bifurcation. Fine distinct growth lines cross and cancellate the radii.

This species resembles *M. alabamensis* Aldrich,\* from the Eocene of Maryland, but differs from it in general outline. It has a less curved anterior border and more radii, which are very distinct from the margin to the beak. The shell is shorter antero-posteriorly, and the posterior margin is more obtusely angulate. The shell of *M. vineyardensis* is also more ventricose and the umbonal ridge more angular and more pronounced.

In general outline this species approaches more nearly *M. grammatus* Dall,† from the Oligocene of Florida. The surface ornamentation is very similar, but judging from Dall's figure his shell is less ventricose and the umbonal ridge less angular and less distinct.

But even closer than to any of these is the resemblance of this species to *M. elegans* Sowerby‡ from the Eocene of England as figured and described by Wood among the Eocene bivalves. In general outline and surface ornamentation the resemblance is very close. *M. elegans* is, however, slightly less angulate at the postero-dorsal margin and judging from the figures is less ventricose.

Compared with the modern *M. plicatula* Lamarck, living along the Atlantic coast, *M. vineyardensis* seems to be nar-

\* Bull. of Am. Palaeont., vol. i, p. 68, pl. v, fig. 13.

† Trans. Wagner Free Institute of Sci., vol. iii, pt. 4, p. 794, pl. xxx, fig. 2.

‡ Paleontological Soc. Monographs, London 1861-71. Eocene Bivalves, p. 65, pl. xii, fig. 5 (c).

rower toward the ventral portion of the shell, while the postero-ventral margin is more nearly a straight line and the radii are more numerous and finer and proportionately more widely separated. In *M. vineyardensis* and *M. plicatula* the mode of increase in the number of the radii by occasional intercalation and bifurcation is very similar. In *M. plicatula* the umbonal ridge is less angulate and less pronounced.

The shell described is a left valve with the following measurements: length 32.5<sup>mm</sup>, width 14<sup>mm</sup>. Several small specimens of this same species occur in other fragments of the concretions, as well as imprints of these shells. These smaller specimens correspond exactly with the growth lines of the younger stages in the larger individuals.

*Modiola vineyardensis* mut. *inornata*.

This mutation is very similar to the type of the species described above, except that the radii are very faintly marked. Fine, distinct, concentric growth lines mark the surface. Distinct radii can be seen on the anterior and umbonal region of the shell. These radii are flattened on top and separated by very narrow impressed lines. They fade out as they pass away from the umbonal and completely disappear on the ventral portion of the shell.

This mutation is represented in the collection by a comparatively small left valve.

*Modiola Hollicki* sp. n. Pl. VIII, fig. 2.

Shell ventricose, with a prominent umbonal ridge extending from the beak to the ventral margin; shell sloping abruptly to the anterior margin and becoming flat in the postero-dorsal part; anterior end rather short; anterior end rounded, front margin slightly arcuate, ventral margin broadly arcuate, rounded, postero-dorsal margin obtusely angulate; cardinal line straight; surface without ornamentation except for rather faint concentric lines of growth.

In general outline this species somewhat resembles *M. Mitchelli* Morris,\* from the Eocene of England. It has a more obtuse postero-dorsal angle and is slightly narrower, with a slightly arcuate anterior margin instead of being emarginate as in that form.

Represented in the collection by two specimens, one nearly perfect left valve (fig. 2) and a valve lacking the beak and hinge area. These occur together with the *Corbulas* (see below) in a fine-grained hard ferruginous lutyte concretion quite different in character from the micaceous sandstone concretions in which all the other fossils are found.

\* Palaeontological Society Monographs (see above), p. 68, pl. xiii, fig. 10.

*Corbula Whitfieldi* sp. n. Pl. VIII, fig. 3.

Shell large for the genus, ventricose and subtriangular; beak high and incurved; anterior margin sharply rounded, ventral margin broadly arcuate in the median and anterior portions but sinuously emarginate posteriorly; the posterior end of the shell is narrow, produced and abruptly truncated. Surface marked by distinct concentric asymmetrical folds or concentric wrinkles which are broadly rounded on top, with the dorsal border slightly broader and not as abruptly sloping as the ventral border. The folds are separated by narrow channeled interspaces. These folds constitute a surface ornamentation, and not lines of growth, as is shown by the fact that they increase in number by intercalation, some folds extending from the anterior to the median portion of the shell, while others extend almost to the posterior end. The principal folds extend to the posterior end and are there sharply flexed. These folds are well defined on the ventral half of the shell and become finer and more crowded on the umbones and almost disappear at the beaks.

This species approaches very closely in general outline and surface ornamentation to *C. alaeformis*\* Gabb, from the Tejon formation of California, but is less than one-half as large. The concentric folds become finer and more crowded on the umbonal region in the specimen from Chappaquiddick than in that figured by Gabb.

This species also somewhat resembles *C. subenqonata*† Dall, from the Eocene of Maryland and Virginia, but differs from that species in being narrower anteriorly and more produced posteriorly, and in the absence of a subcarinate ridge extending from the umbo to the posterior margin. The concentric folds are also more crowded and less prominent on the umbonal region.

The material in hand represents a right and a left valve. These specimens occur in a very fine-grained hard ferruginous lutyte concretion, quite different in character from the material in which most of the other fossils are found.

*Anomia simplexiformis* sp. n. Pl. VIII, fig. 10, 11.

Shell subovate and prolonged in the region of the beak; left valve very globose, nearly equilateral, somewhat irregular; beak located in median dorsal portion of the shell, submarginal, slightly projecting and incurved; surface without plications or ornamentation, except possibly very faint indications of concentric lines of growth.

\* Palaeontology of California, vol. ii, p. 177, pl. xxix, fig. 63.

† Md. Geol. Sur., Eocene, p. 163, pl. xxxii, figs. 1, 1a, 2, 2a, 2b.

A portion of a right valve, probably of this species, is present in a fragment of the ferruginous concretion (fig. 11). It is very much flattened, more or less irregular, with large byssal opening and indications of very faint concentric growth lines.

This species is represented by several complete or nearly complete left valves, varying greatly in size, the length ranging from ten to thirty millimeters. It resembles very closely the modern *A. simplex* from the shores of Long Island. It has the same general outline and shape, and approaches that species in size and in the absence of surface plications and other ornamentations.

*Anomia paucistriata* sp. n. Pl. VIII, fig. 12.

Shell subcircular, somewhat irregular; left valve convex, nearly equilateral; beak submarginal, dorso-medially placed and not pronounced; surface marked by a few faint radiating striations, crossed and cancellated by very fine concentric lines of growth.

This species is smaller than the preceding, averaging in length about ten to twelve millimeters. It is represented by several left valves. Right valve unknown.

*Glycymeris* sp. ?. Pl. VIII, fig. 13.

Represented by several internal molds not preserving characters sufficient for specific description. The figure shows the internal characters of the shell and is drawn from a wax imprint made from a mold.

This species is smaller and more ovate in form than *G. idoneus* Conrad, from the Nanjemoy and Aquia formations of Maryland. In size, form and general appearance it resembles more closely *Glycymeris (Pectunculus) decussatus* Sowerby, from the Eocene of England.

*Nucula* sp. ?.

Represented by a few small internal molds. In one at least the dental characters are very well preserved. In general outline these resemble very closely *N. potomacensis* Clark, from the Eocene of Maryland, but do not preserve sufficient characters for specific identification or description.

*Turritella* sp. ?. Pl. VIII, fig. 4.

Shell small, spire high, angle about twenty-five degrees each whorl marked by a distinct, well-defined anterior and less prominent posterior spiral carinate ridge, following around above and below the suture, otherwise the surface is smooth and free from ornamentation; suture distinct; whorls closely placed and rapidly increasing in size.



This species resembles very closely a *Turritella* not specifically identified from the Eocene of Whellock, Texas, in the University collection. The Whellock specimen is larger but has the same apical angle, is free from ornamentation and has the anterior and posterior carinate ridges present but faintly marked.

This description is based on a wax imprint made from a very perfectly preserved external mold in a red micaceous sandstone concretion. The full length of the shell is not represented, so that the number of whorls and dimensions cannot be given. There are no characters of aperture and lips apparent.

*Terebra* sp. ?. Pl. VIII, fig. 5.

Shell elongate, spire elevated, whorls closely placed, rapidly enlarging, flat on the outer surface between suture, free from ornamentation or with very faint revolving lines, aperture elongate elliptical, pointed anteriorly, rounded posteriorly; outer lip thin and broadly arcuate, inner lip smooth without callus or ridge.

The specimen figured occurs on the edge of a small fragment of rock. The apex is concealed in the matrix and the anterior end of the aperture is slightly injured so that it does not show the minute characters.

*Terebra juvenicostata* sp. n. Pl. VIII, fig. 6.

Shell small and slender, spire elevated; apex pointed, acute with an apical angle starting at about thirty degrees and decreasing toward the body whorl where the sides of the spire approach to parallelism; the whorls are closely placed and flattened between the sutures. There are distinct ribbings on the earlier whorls which become less distinct along the advancing spire and disappear on the body whorl.

*Odostomia semicostata* sp. n. Pl. VIII, fig. 7.

Shell small, consisting of six or seven volutions, spire elevated, apical angle thirty degrees; sutures very pronounced; volutions flattened convex between sutures; earliest whorls marked by distinct transverse plications or ribs which become almost or quite obsolete on body whorl; outer lip distinctly denticulate within.

The aperture and columella of this specimen is not fully preserved so it cannot be accurately described. Length of shell as preserved 9.5<sup>mm</sup>.

*Odostomia crenulata* sp. n. Pl. VIII, fig. 8.

Shell very small, spire high and closely coiled, apex subacute, whorls flattened externally, faintly crenulate along the posterior margin, suture distinct, aperture and lips unknown.

Genus? sp.? Pl. VIII, fig. 9.

Shell small, loosely coiled, apex acute, whorls five or six, well rounded, rapidly increasing in size, smooth without any ornamentation: suture quite deep and distinct, character of aperture and lips unknown.

This species is very similar to a *Limnaea* in shape but can hardly be one of these as it appears to be a salt water form.

Represented in the collection by a small but very perfect external mold of which a wax impression was taken.

*Ostrea* sp.?

Several small internal molds of representatives of this genus are present among the fragments of the concretion. These are not sufficiently well outlined to be specifically determined. They seem to represent at least two or three different species and all are comparatively very small.

*Cardium?* sp.?

Several casts doubtfully referred to this genus are to be found among the fragments of concretion collected by Dr. Hollick.

These fossils represent a new and distinct fauna markedly different from that of any other Eocene deposits of this country. Since this fauna does not contain a single species in common with the Eocene faunas of the Atlantic slope and gulf deposits, it cannot be accurately correlated with these beds and assigned its proper place in the geologic scale. Nevertheless from the general characteristics of the contained species and their affinities to forms from widely distant provinces, the horizon of these deposits can be ascertained with some approximation to the truth.

Considering the marine Eocene deposits of this country as a whole, we find that they naturally fall into several provinces lithologically quite distinct, and containing faunas with very few species in common. In New Jersey there is a small and isolated area known as the Shark River beds from their outcrop along that river. According to Clark, these beds represent lower Eocene and rest conformably upon the Cretacic below. By early writers they were considered a part of the Cretacic, as there was no marked line of separation between them and the underlying strata. The fossils, however, were found to be of undoubted Eocene character, and although the fauna was lacking in some of the most widely distributed Eocene species, it still contained no characteristic Cretacic forms.

These Shark River deposits were thought by Harris to represent a higher horizon than the Eocene deposits of Maryland

and Virginia, and Dall, in his correlation tables of the North American Tertiaries, has placed them in the Claibornian stage or equivalent to upper Middle Eocene. The fossils of this province differ so widely from those of the regions immediately to the south that correlation is very difficult, and even now there is doubt as to the exact position of these beds.

A second province of the Eocene, generally known as the Pamunkey formation from its typical development along the Pamunkey River in Virginia, begins in Delaware and extends across Maryland well into Virginia. Lithologically these deposits have more similarities to those of the provinces to the south than to the Shark River beds of New Jersey, yet they are sufficiently distinct both lithologically and in their contained fauna to require complete separation. According to Clark these deposits "constitute a single geological unit."

A third province embraces the Eocene deposits of the Carolinas and Georgia and affords a far more complete series of Eocene strata than either of the more northern areas. The lower beds consist of arenaceous and conglomeratic deposits, rather sparingly fossiliferous, probably because the material by its very nature was not adapted to permit the preservation of fossils. The middle and upper beds are well developed and represented by limestones and marls containing an extensive fauna, yet quite distinct from the surrounding provinces.

A fourth, the Gulf province, is by far the most extensive of the Eocene areas. It extends from Florida to Texas and includes the so-called Mississippian embayment, an area extending well up into the Mississippi basin. All stages of the Eocene are more fully represented, but both lithologically and paleontologically this province is very distinct from those along the Atlantic coast. Peculiar conditions in this area resulted in the interbedding among the other deposits of many lignitic strata.

A fifth marine Eocene province occurs along the Pacific coast, and outcrops along the coastal range in California, Oregon and Washington. These deposits are generally known as the Tejon group and were originally referred to the Cretacic. Later study has shown them to be of Eocene age, and yet their fauna differs widely from those of the Atlantic and Gulf provinces.

The fauna from Chappaquiddick represents a new and distinct Eocene province, differing from all the other provinces but no more widely different from these than they are from one another. Although in this fauna there are several species somewhat resembling those of the provinces to the south, on the whole it would seem to be more closely allied to the Eocene of England. The genera most abundantly represented

in these Chappaquiddick deposits, e. g., *Modiola*, *Glycymeris*, are also among the most abundant in the English deposits. These same genera, although represented in the Atlantic and Gulf provinces, are there more sparsely distributed and occur with other more abundantly represented genera that appear to be altogether wanting in the Chappaquiddick deposits.

A comparison of this Chappaquiddick fauna with other Eocene faunas indicates that it is of lower Eocene age, the species most closely resembling those found in this fauna being found in the lower beds of the Atlantic and Gulf provinces, the Tejon of California and the lower beds of England. These deposits may possibly be of the same age as the Shark River beds of New Jersey, but being deposited in a region separated from this have no forms in common with it, but such correlation could be only conjecture. As the correlation of the well known Eocene deposits is even yet very uncertain, it is unnecessary and impossible to place these beds any more definitely than simply to say they are lower Eocene.

Columbia University, New York City.

#### EXPLANATION OF PLATE VIII.

FIGURE 1.— <i>Modiola vineyardensis</i> .....	p. 232
FIGURE 2.— <i>Modiola hollicki</i> .....	p. 232
FIGURE 3.— <i>Corbula Whitfieldi</i> .....	p. 233
FIGURE 4.— <i>Turritella</i> sp. ? .....	p. 234
FIGURE 5.— <i>Terebra</i> sp. ? .....	p. 235
FIGURE 6.— <i>Terebra juvenicostata</i> .....	p. 235
FIGURE 7.— <i>Odostomia semicostata</i> .....	p. 235
FIGURE 8.— <i>Odostomia crenulata</i> .....	p. 235
FIGURE 9.—Genus ? sp. ? .....	p. 236
FIGURES 10 and 11.— <i>Anomia simplexiformis</i> .....	p. 233
FIGURE 12.— <i>Anomia paucistriata</i> .....	p. 234
FIGURE 13.— <i>Glycymeris</i> sp. ? .....	p. 234



FIG. 1,  $\times \frac{1}{2}$ .

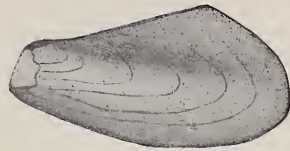

FIG. 2,  $\times \frac{2}{3}$ .

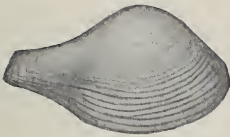

FIG. 3,  $\times \frac{2}{3}$ .



FIG. 4,  $\times \frac{2}{3}$ .



FIG. 5,  $\times \frac{2}{3}$ .



FIG. 6,  $\times \frac{2}{3}$ .



FIG. 7,  $\frac{2}{3}$ .



FIG. 8,  $\frac{2}{3}$ .



FIG. 9,  $\frac{2}{3}$ .



FIG. 10,  $\times \frac{1}{2}$ .



FIG. 11,  $\frac{2}{3}$ .



FIG. 12,  $\times \frac{2}{3}$ .

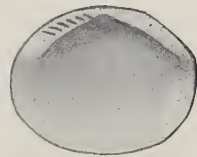

FIG. 13,  $\times \frac{2}{3}$ .



ART. XXVII.—*The Production of Radium from Uranium* ;  
by BERTRAM B. BOLTWOOD.

THE hypothesis that radium is a disintegration product of uranium has been greatly strengthened through the demonstration of the fact that in radio-active minerals the quantity of radium is directly proportional to the quantity of uranium present.\* On the basis of the disintegration theory a proportionality of this sort is to be expected between the parent element and its radio-active successor.

Additional data on this highly important question are however desirable, and a single experiment likely to further elucidate the problem has been independently undertaken by a number of different investigators. This experiment consists in observations conducted on a carefully purified uranium salt with a view to determining whether, with the lapse of time, measurable quantities of radium will be produced within it. If radium is a *direct* product of uranium through the intermediate stage of uranium-X and if the average life of radium is approximately 1,000 years, then it can readily be deduced that, with the delicate methods of measurement at command, the quantity of radium formed in a few hundred grams of uranium salt will be readily detectable and measureable after the lapse of a period no longer than a month. If, however, one or more transition products of a relatively slow rate of change intervene between the substance uranium-X and radium, the production of radium will be so protracted that no quantity of it sufficiently great to permit its detection will be formed within a greatly extended period.

The difficulties involved in the experimental demonstration of the growth of radium do not appear to be great. Uranium forms no radio-active, gaseous disintegration product, while the radium emanation affords a most convenient means of quantitatively estimating any radium which may be present. A solution of a carefully purified uranium salt can therefore be prepared and can be tested at intervals for radium emanation. If radium is formed from the uranium its existence will be indicated by the presence of radium emanation in the uranium solution.

Three papers in which an experiment of this character is described have been published by Mr. Soddy.† In the first

\* Boltwood, *Phil. Mag.* (6), ix, 599; Strutt, *Proc. Roy. Soc. Lond.*, lxxvi, 88; McCoy, *Berichte d. deutsch. chem. Ges.*, xxxvii, 2641.

† "The Life-history of Radium," *Nature*, lxx, 30; "The Origin of Radium," *Nature*, lxxi, 294; "The Production of Radium from Uranium," *Phil. Mag.* (6), ix, 768. Mr. Whetham has also published two contributions on the same general topic (*Nature*, lxx, 5; *ibid.*, lxxi, 319) in which he states

paper, published May 12, 1904, very scanty details of the experimental procedure are given, but a summary of the conclusions reached at that time by the author is as follows:

1. The quantity of radium which has accumulated in one kilogram of uranium nitrate in twelve months is less than  $10^{-11}$  gram.

2. The question so far as the production of radium from uranium is concerned is practically settled.

3. If uranium changes into radium, less than one ten-thousandth part of the theoretical quantity is produced during the first year's accumulation.

4. The evidence may be taken as indicating that uranium is not the parent element of radium.

The second paper, published Jan. 26, 1905, eighteen months from the commencement of the experiment, is likewise lacking in a detailed account of the experimental methods, but the author states that measurements carried out at that time with the kilogram of uranium nitrate under observation indicate that it contains  $1.5 \times 10^{-9}$  gram of radium, a quantity which, while of considerable relative magnitude, is only one five-hundredth of the amount to be expected from the disintegration theory on the assumption of a direct change. The author suggests that the greater part of the radium emanation may (under the conditions of the experiment) be retained in the uranium solution and not evolved as a gas. On the basis of the amount of radium assumed to be then present it is deduced that the fraction of uranium changing per year is  $2 \times 10^{-12}$ .

After pointing out certain sources of error likely to have exercised a disturbing influence during the elapsed period of observation, the author adds,—“if the whole series of measurements from the commencement are recalculated, eliminating the error alluded to, they are fairly consistent with there having been a steady production of radium at this rate continuously from the commencement.” One of the sources of error alluded to was the introduction of very considerable quantities of radium salts into the laboratory during the period when the kilogram of uranium nitrate was under observation. It is stated that the presence of this radium greatly disturbed the electroscope in which the measurements were conducted. Additional difficulty had been previously experienced in attempting to standardize the measuring instrument with the emanation corresponding to a known weight of pure radium salt.

that he also believes that he has observed indications of the growth of radium in uranium compounds. Since Whetham's communications contain neither any account of experimental details nor any record of quantitative measurements, it is impossible to judge as to the value of the data on which the author's conclusion is based.



The third and more elaborate article by the same author appeared in the June number of the Philosophical Magazine. The data briefly given in the earlier articles are here treated at greater length and a closer insight can be gained of the experimental methods and the results on which the author's later conclusions are based. Although it is stated in this paper that observations had been taken occasionally over a period of eighteen months and that these observations indicated a *gradual* growth of the emanating power of the uranium solution, the only definite and directly comparable numbers are restricted to a total period of about three weeks (Dec. 17, 1904 to Jan. 9, 1905) and include only four measurements conducted at the close of the period of observation.

Without entering into a discussion of various minor details in Mr. Soddy's papers, it is desired to call particular attention to the following important considerations in relation to the experimental data submitted:

*First.* No conclusive evidence is brought forward to show definitely how much or how little radium was present in the uranium solution at the commencement of the experiment.\*

*Second.* It appears extremely possible that the increase in the content of radium which Mr. Soddy believes he has observed in his uranium solution may in fact have been due to the accidental and unconscious introduction of radium salts during the tests conducted at the end of the twelve months period. According to his own statements these tests were carried out in a laboratory notably contaminated with various radio-active products, and the accidental introduction of the sub-microscopic quantity of material ( $1.6 \times 10^{-9}$  gram.) which was afterwards detected would account for the later positive results. The liability of contamination from an extraneous source is strongly suggested by the behavior of Mr. Soddy's electro-scope, in which the normal air leak has risen from 0.048 division per minute to 1.56 division per minute, an increase of over thirty times, during the period covered by his experiments.

The conditions essential to the elucidation of the question of the actual production of radium in uranium compounds would seem to be:

\* The writer of the present paper convinced himself at the beginning of his own experiments that the method of procedure followed by Mr. Soddy in testing his solutions for radium emanation is entirely unsuited for the determination in question. A concentrated solution of incompletely purified uranium nitrate containing traces of radium gave up only a fraction of the total radium emanation generated within it when the solution was allowed to stand for days in contact with a small air space and air was bubbled through it. It was speedily found that only by boiling the solution vigorously for about fifteen minutes could the total emanation present be positively separated.

(a) The employment of a method for the determination of radium which gives positive and quantitative results. The method must be suitable for the determination of very small quantities of radium and must be capable of indicating the *maximum* quantity present at all times.

(b) The preparation of a pure compound of uranium and the demonstration that the compound is initially free from radium.

(c) Proper conditions for testing and preserving the uranium salt in order to preclude the introduction of radium or radium emanation from external sources, so that if the presence of radium is noted it can be assumed with certainty that the radium found has actually been formed in the solution.

It would appear that none of these essential conditions has been fulfilled in the experiment described by Mr. Soddy.

The writer of the present paper has been conducting an experiment on the growth of radium in a uranium solution for the past thirteen months. The conditions of the experiment were the following: In May, 1904, a kilogram of "purest uranium nitrate" was purchased from Eimer & Amend of New York City. This material was tested qualitatively for radium (through the emanation) and readily detectable quantities of this element were found to be present. The salt was dissolved in distilled water and the solution was filtered. The compound was then recrystallized five separate times, the conditions being so chosen that the separate crystals of each of the different crops were not over two millimeters in cross-section. The mother liquors were each time removed from the crystals on a suction filter, and the crystals were washed with a small quantity of ice-cold water.

The final yield of purified material was a little in excess of 200 grams. Of this 100 grams were taken and dissolved in pure, distilled water. This solution was introduced into a glass bulb with a capacity of approximately 400<sup>cc</sup>, diluted to about 250<sup>cc</sup>, and the neck of the bulb was drawn out into a short capillary and sealed in the flame of the blowpipe. The solution was sealed up on July 8, 1904. Thirty days later the bulb was opened under conditions which precluded the escape of any portion of the contained gases and the entire gaseous contents were removed and transferred to an electroscope. In order to completely displace the dissolved gases and any radium emanation which might have been present the solution was boiled vigorously for about fifteen minutes.\*

\* The removal and collection of the gaseous contents of the bulb was accomplished by the use of the apparatus which has been described in a previous paper (this Journal, xviii, 379). The neck of the bulb containing the uranium solution having been first notched with a file, it was inserted in the rubber tube D, the point was broken off within the tube, and the gases displaced from the bulb on heating were collected in the burette D, which was filled at the start with boiling water.

The type of electroscope used in this investigation has already been described (this Journal, xviii, 97). The emanation from the radium associated with 0.1 gram of uranium in a radio-active mineral caused a leak of approximately 21 divisions per minute. Assuming that the 100 grams of uranium nitrate contained 48 grams of uranium, the leak corresponding to the quantity of radium in radio-active equilibrium with 48 grams of uranium would be approximately 10,000 divisions per minute. The normal air leak of the instrument was 0.012 division per minute, and an increase of 0.005 division per minute could have been detected with certainty. The electroscope was therefore capable of indicating the presence of a quantity of radium equal to  $5 \times 10^{-7}$  of the equilibrium quantity. The actual quantity of radium equivalent to a leak of 0.005 division per minute was  $1.7 \times 10^{-11}$  gram.\*

On introducing the gases present† in the uranium solution into the electroscope *no increase* in the leak of the instrument could be detected although the observations were continued over a period of eight hours. The quantity of radium present at the start was therefore less than  $1.7 \times 10^{-11}$  gram.

The uranium solution in the bulb was allowed to cool, and the neck of the bulb was again sealed. At the end of six months from the start, in January, 1905, the uranium solution was again tested under conditions identical with those under which the first test was carried out. Entirely negative results were obtained and the quantity of radium then in the solution was still less than  $1.7 \times 10^{-11}$  gram. A similar test was conducted on August 2, 1905, 390 days from the commencement, and no evidence of the presence of radium emanation was even then obtained. It can therefore be positively stated on the basis of sound experimental data that in 390 days the quantity of radium formed from 48 grams of uranium in a uranium nitrate solution is less than  $1.7 \times 10^{-11}$  gram.

The quantity of radium which can have been produced in the given time is therefore less than one two-millionth of the equilibrium quantity and less than one sixteen-hundredth of the quantity which would be expected from the disintegration theory if the value of  $\lambda$  for radium is taken as  $8.8 \times 10^{-4}$  (year)<sup>-1</sup>.‡ The quantity is furthermore only about one-tenth of the quantity assumed by Mr. Soddy to have been formed from an equal quantity of uranium in his solution during an interval of eighteen months.

It is important to add that the whole series of measurements has been conducted in a laboratory which has been carefully

\* Rutherford and Boltwood, this Journal, xx, 55.

† At the end of the 30-day period.

‡ Rutherford, Trans. Roy. Soc. London, (A) cciv, 215.

protected from contamination by the salts of radium or other radio-active substances, and that the electroscope used has been reserved for this particular research, its original normal air-leak having remained unaltered throughout the entire period. It has therefore been unnecessary to introduce any corrections or to make any allowances for possible errors due to known causes of any description.

The experiments described in this paper are considered to indicate that the results obtained by Mr. Soddy are without significance and that one or more products of a slow rate of change intervene between uranium and radium.

It is claimed, moreover, that the conclusions in Mr. Soddy's first paper, so far as they relate to the *direct* transformation of uranium into radium, are more truly in accord with the actual facts than are those contained in his later publications.

139 Orange street, New Haven, Conn.  
August, 1905.

## SCIENTIFIC INTELLIGENCE.

## I. GEOLOGY.

1. *Explorations in Turkestan with an account of The Basin of Eastern Persia and Sistan. Expedition of 1903, under the direction of RAPHAEL PUMPELLY.* 4to, 324 pp., 6 pls., 174 figs in text. Washington, D. C. (Published by the Carnegie Institution of Washington. Publication No. 26. April 1905.)—This publication contains the following five papers: Archeological and Physico-Geographical Reconnaissance in Turkestan by Raphael Pumpelly; A Journey across Turkestan by William M. Davis; Physiographic Observations between the Syr Darya and Lake Kara Kul, on the Pamir, 1902, by Raphael W. Pumpelly; A Geologic and Physiographic Reconnaissance in Central Turkestan, by Ellsworth Huntington; The Basin of Eastern Persian and Sistan, by Ellsworth Huntington.

Professor Pumpelly states in the introduction that "At the end of 1902 the Carnegie Institution voted a grant to me 'for the purpose of making, during the year 1903, preliminary examination of the Trans-Caspian region, and of collecting and arranging all available existing information necessary in organizing the further investigation of the past and present physico-geographical conditions and archeological remains of the region.'

"The investigation was proposed because (1) there is a school that still holds the belief that central Asia is the region in which the great civilizations of the far East and of the West had their origins; and (2) because of the supposed occurrence in that region, in prehistoric times, of great changes in climate, resulting in the formation and recession of an extensive Asian Mediterranean, of which the Aral, Caspian, and Black seas are the principal remnants.

"It had long seemed to me that a study of Central Asian archeology would probably yield important evidence in the genealogy of the great civilizations and of several, at least, of the dominant races, and that a parallel study of the traces of physical changes during Quaternary time might show some coincidence between the phases of social evolution and the changes in environment; further, that it might be possible to correlate the physical and human records and thus furnish a contribution to the time scale of recent geology.

"At my request Professor William M. Davis assumed charge of the physico-geographical part of the preliminary reconnaissance."

In concluding he remarks that "We have shown that the recent physical history of the region is legibly recorded in glacial sculpture and moraines, in orogenic movements, in valley cutting and terracing, in lake expansions, and in the building up of the

plains, and we have made some progress in correlating these events.

"We have also found full confirmation of the statements as to a progressive desiccation of the region of long standing, which has from a remote period continually converted cultivable lands into deserts and buried cities in sands.

"We have found, widely distributed, great and small abandoned sites of human occupation, with evidences of great antiquity.

"We have reason to think that a correlation of these physical and human events may be obtained through a continuance of the investigation, and that archeological excavations will throw light on the origin of Western and Eastern civilization."

In the second article Professor Davis describes his observations upon the Caspian region with its abandoned shore lines up to 600 feet above the present water-level, and the traces of the Pliocene sea whose deposits, as the Russian geologists have shown, underlie the plains of southern Turkestan. He says of the Piedmont plains that: "Since the withdrawal of the Pliocene sea, the eastern and southern borders of the plains of southern Turkestan appear to have been aggraded by the rivers that flow out upon them from the mountains. That a certain measure of such constructive action has taken place is announced by the Russian geologists, but it is not apparent that the full measure of river action has been recognized. Some of the strata of the plains are said to be not fluvial but lacustrine, because they are of fine texture and uniform structure, without the variable layers of gravel that are by implication supposed to be always indicative of river work; but this seems to be a simpler solution than the problem deserves. There are many rivers that do not carry gravel, and there are many river plains whose smooth surface must receive very even and uniform deposits of flood-laid silts over large areas. Records of boring are quoted by Walther which show river muds on sand and loess to a depth of nearly 50 meters beneath the bed of the Amu River at Charjui, where the great railroad bridge was built. The record of a well boring at Askhabad, quoted by the same author, shows variable piedmont deposits over 2,000 feet deep. It seems, indeed, as if we had in the plains of Turkestan and the Great Plains of our West one of the most striking of the many physiographic resemblances between Eurasia and North America; and that there as well as here an increasing share may be given to the action of aggrading rivers in forming the plains, as observations are extended. It is well known that the tide of geological opinion in this country has in recent years turned more and more toward a fluvial origin for the strata of the Great Plains that slope eastward from the Rocky Mountains, and the traditional lacustrine origin of the plains strata has been repeatedly questioned; so we may expect, as closer attention is given to the details of river-laid formations, that a larger and larger share of the fresh-

water strata that slope westward from the mountains of Central Asia may be interpreted as fluvial rather than as lacustrine."

"The irregular structure of the piedmont slope, as exposed in cuts along the railroad line, is well described by Walther. There is a frequent and irregular alteration of stratified or massive loess-like clay, finely stratified sands, and coarse gravel, with many local unconformities; all this being the result of the variable action of floods that sweep suddenly, unguided by channels, down the piedmont slope; now eroding, now depositing; here sweeping along coarse blocks, there depositing fine silts. Ten miles south of Askhabad, where the railroad station is 819 feet altitude, we saw, when returning by the Meshed road from an excursion in the Kopet Dagh, more abundant piedmont deposits of mountain-waste dissected to depths of several hundred feet. A great thickness of these deposits has been penetrated by the artesian boring in the suburbs of Askhabad, already mentioned, 2000 feet deep, and therefore with more than half its depth below sea level, but without securing a water supply. The whole depth, as shown in the record quoted by Walther, is in variable layers of clay, sand, and gravel, similar to the deposits seen in the barrow-pits near the railroad embankments, or in the natural sections; and all of this heavy deposit is therefore best explained by conditions and processes like those of to-day during persistent depression of the surface. The failure to secure a water supply from this deep well is in itself very suggestive of the irregular underground structures and of their torrential origin."

An excursion into the Kopet Dagh and the mountains of Persia revealed abundant evidence of sub-recent terracing in the valleys of a character to suggest a relative uplift of the heart of the chain. The desert plains from Askhabad to Samarkand are characterized by aggrading rivers. "The most notable feature of this district was the absence of valleys. The rivers have channels in which their waters are usually restrained, but there were no valleys in which the river floods were limited. The plains were open to overflow as far as flood supply held out. We were told, however, that some distance upstream (to the south) the Murg-ab has a flood-plain slightly depressed beneath the plain. This we interpreted as meaning that the river had there changed its habit from aggrading to degrading. On crossing the Amu at Charjui we saw a low bluff on the north or right of its course, although on the south the plain is not significantly above the river.

"The general absence of valleys is a natural, indeed an essential, feature of a fluvial plain in process of aggradation by flood deposits. It is peculiarly appropriate to rivers like the Tejen and Murg-ab, which dwindle away and end on the plain, so that every grain of sand and every particle of silt must be laid down as the water volume lessens and disappears. The absence of valleys would, on the other hand, be surprising in a

lacustrine or a marine plain, for the reason that coincidence could hardly be expected between the slope that might be given to such a plain when it is laid bare and the slope that is satisfactory to the graded rivers that run across it. It is not, however, as has already been pointed out, always the case that fluviatile plains have no valleys eroded beneath their general level. The river-made plains of northern India are now commonly somewhat trenched by their rivers. Our Great Plains, piedmont to the Rocky Mountains, are likewise in process of dissection by their rivers. The plains of Turkestan are therefore somewhat exceptional in this respect. As a result we had unfortunately no opportunity of seeing sections of the plains in which the structure of the deposits could be examined. A well on the Czar's estate at Bairam Ali, a modern village near Old Merv, where we were most agreeably entertained by the superintendent. Mr. Dubassof, was said to have shown nothing but 'sand and loess.' The desert and river deposits found by borings beneath the Amu River beds at Charjui have already been noted. The inspection of these vast plains of silt was very suggestive in connection with the problematic origin of the fresh-water Tertiary formations of the western United States. Certainly no one who sees the river-made area of the plains of Turkestan can doubt the capacity of rivers to lay down extensive fine-textured deposits."

In regard to the Tian Shan mountains Professor Davis states that "A number of the mountain ranges that we saw were of vigorous form, with sharp peaks and deep-carved valleys, in which it was impossible to recognize any trace of the original unsculptured mass; but certain observations made in the central and northern ranges, near Lakes Son Kul and Issik Kul, and on the steppes that border the mountains on the north, led to the belief that the region had been very generally worn down to moderate or small relief since the time of greater deformation, which probably occurred in the Mesozoic age; that large areas of subdued or extinguished mountain structures are still to be seen in the low ranges and in the steppes north of the Ili River; and that the present relief of many of the higher Tian Shan ranges is the result of a somewhat disorderly uplift and of a more or less complete dissection of dislocated parts of the worn-down region. Mr. Huntington's report shows the application of these conclusions to a large part of the central and southern Tian Shan." The space devoted to a notice of so wide ranging a report forbids further detailed mention of the numerous observations of the author upon river and glacial phenomena of the valleys of the Tian Shan.

In the article by Mr. Pumpelly, an account is given of the Kara Kul, a lake of bitter salt water, and its desert shores, and also a good description of the moraines in the mountains. Indications of two long-separated ice advances were noted and signs of a feeble third. Variations of lake level and ice advance are attributed to climatic control. Evidence is discussed



to support the supposition that in early Pleistocene time the Alai mountains wasted down until a detritus-covered piedmont plain formed on the north of the range, whereupon a dislocation seems to have occurred nearly parallel to the range and north of it with sinking of the plains still farther north or with uplift of the range. The relations of the river work to this change of altitude are briefly explained.

In his article on central Turkestan Mr. Huntington gives a summary of the geology and topographic development. Of the Paleozoic series he states: "In Central Turkestan a single succession of strata is repeated again and again, with only slight local modifications. The oldest observed formation is an ancient white marble, shot through and through with intrusions of granite. It was noticed only in the Alai Mountains in the neighborhood of Kok Su and Karategin. Its junction with the overlying formation was not seen, but the contact presumably shows an unconformity, as a conglomerate near the base of the covering strata contains pebbles of the marble. The granite which is intruded into the marble is of much later date, for it occurs abundantly in the Paleozoic series in the ridges of the Tian Shan plateau and along the north side of the Alai range. The main body of the Paleozoic series is a great thickness of limestones, many of them slaty, which are stated by Tchernachef to be of Devonian and Carboniferous age. They are greatly folded and have been penetrated not only by granite intrusions, but also by some basaltic lavas, as may be seen, for instance, in the Sugun Valley west of Shor Kul. The folding of the Paleozoic strata is of the sort which is associated with mountain building, hence at the end of the Paleozoic era or in the early part of the Mesozoic this part of Central Asia must have been highly mountainous. In evidence of this it may be pointed out that the succeeding unconformable conglomerates are so coarse that they could only have been formed subaerially in a region of considerable relief, and yet at the time of their deposition the old folds of limestone and slate had already suffered great denudation. As a rule, the hard Paleozoic strata are found in the highlands, while the softer Mesozoic and Tertiary strata occur in basins among the highlands and mountains; but this seems due less to the superior resistance of the older rocks than to the fact that they were bent down where they are covered, and that the younger strata were largely formed in the very basins which they now occupy."

"The conditions under which the Mesozoic-Tertiary series were deposited seem to have been largely subaerial, or at least non-marine. The coarse conglomerates at the base probably indicate arid or semi-arid conditions in a region of considerable relief. As relief grew less, or as the climate grew moister, the gravel of the conglomerate gave place to sand, and that in turn to shale; in the latter are four or five coal seams. The next period, that of the vermilion beds, seems to have opened at a time of sub-

aerial deposition when the conglomerates and the cross-bedded sandstones were formed; but toward the end the encroachment of the sea is indicated by the deposition of the marls and fossiliferous limestones. Elsewhere throughout the whole Mesozoic-Tertiary series fossils seem to be wholly absent, although the deposits are well fitted to preserve the remains of plants and animals if any had existed; but here the calcareous strata, which show other evidences of being marine, contain fossils in abundance. Above the limestones the strata are at first red, as though the shallowing of the sea allowed the very highly weathered soil of an old land mass to be washed farther and farther out into the area of deposition. The succeeding formations, the pink and brown sandstone and the brown conglomerate, show a nearer and nearer approach to present conditions. It appears as though, after the retirement of the sea, the land was covered with great playas, on which water first stood in thin sheets, forming ripple-marks in the mud, and then retired or was evaporated, allowing the surface to become sun-cracked. As time went on streams began to flow across the playas, at first slow and broad and able to cut only shallow channels, which were afterwards filled and covered, assuming the form of very thin lenses of a material slightly different from that of the surrounding playa strata. Then, as the strength of the streams increased, sand was deposited over the whole area, and the channels, now deep and distinct, were filled with gravel. Lastly, gravel was deposited almost everywhere."

Central Turkestan exhibits a recently warped and elevated peneplain the dissection of which is assumed to have begun in the closing Tertiary, though the uplift is placed mainly in Pleistocene time. Summit glaciers were found among the mountains between Marghilan and Issik Kul. From his observations upon the ancient moraines of these glaciers the author concludes that: "Wherever old moraines are well developed they indicate that the glacial period is divisible into two or more subdivisions; and where the valleys are large and reach high enough still to contain glaciers the number of these subdivisions is five, marked by successive moraines, each of which is smaller and at a greater altitude than its predecessor. Two theories present themselves as worthy of consideration in explanation of these facts. According to one there was but a single glacial advance and retreat. The retreat was not accomplished uniformly or rapidly, but by successive steps, after each of which there was a long pause that gave opportunity for the accumulation of a moraine; thus five moraines were formed by each glacier and those now in process of deposition belong to the sixth step of the same long retreat. According to the other theory, each moraine represents a distinct glacial epoch, during which the glaciers first advanced and then retreated. Under this theory the intervals of retreat were as warm as or warmer than the present and the ice retreated far into the mountains during each of them.

“For fifteen out of the twenty-four glaciated valleys examined the first theory is sufficient, but it will not explain the other nine. In eight of these nine valleys one or more of the older moraines lies upon a topography different from that of to-day, so as to suggest that the moraines and the floor on which they rest have been trenched by a valley of stream erosion. In this valley lie the younger moraines, leaving the older moraines as terraces which extend beyond the later moraines both up-valley and down-valley; the up-valley extension of the morainic terrace gives a minimum measure of the retreat of the glacier during the interglacial epoch. In the ninth valley a detached portion of an older moraine lies far up-valley from its successor and even above the main part of the modern moraine. These facts are to be explained only by supposing a glacial retreat and advance in each interglacial epoch, and hence a warmer interglacial epoch between colder glacial epochs. Another sort of evidence of a warmer interglacial epoch is found where one moraine lies upon its predecessor in an attitude which indicates that before the deposition of the younger moraine the older one was first an area of erosion and later of deposition. All these facts accord with the theory of successive advances and retreats, and thus warrant the division of the glacial period into several glacial and interglacial epochs. In one place or another signs of an interglacial retreat are found between each successive pair of the four earlier moraines, while the fifth moraine stands apart from the others, except at Kan Su, where the time during which there is evidence of retreat may be either between the third and fourth or fourth and fifth advances of the ice. Everywhere the climate of the successive glacial epochs seems to have grown less severe, and the duration of the interglacial epochs seems to have diminished in the same ratio.”

A succession of terraces found in the valleys are regarded as the result of a climatic change. The number of climatic swings thus inferred agrees essentially with the series of cold epochs based upon the occurrence and distribution of moraines. He states: “The essential point in our study of the recent geological history of Turkestan is this: From three separate lines of reasoning, based on the allied yet distinct phenomena of glaciation, terracing, and lake expansion, we arrive at the same conclusion, namely, that during the Quaternary era there have been a number of colder or glacial epochs, five or more, separated by warmer interglacial epochs when the climate was similar to that of to-day; and further, that these epochs progressively decreased in length and intensity.”

In the final article on the basin of eastern Persia and Sistan Mr. Huntington discusses briefly the geology and in a more complete way the physiography of this desert basin. In a summary paragraph he states: “The facts set forth above, so far as they warrant any conclusion, suggest that in Eastern Persia the lower strata of the basins are generally greenish shales, which are now exposed along the edges of the basins where they have been

extensively warped and compressed. Above them occur reddish silts containing more or less sand and gypsum and warped like the underlying shales, although to a less extent. In certain places toward the top of the series the red strata alternate with green clays. Above all lie the deposits of silt and gravel which are to-day accumulating. Although these different strata show varying degrees of warping along the edges of the basins, it is noticeable that toward the centers they approach the horizontal position. It is probable that in the centers of many of the basins an uninterrupted series of strata has been deposited from the time of the post-Cretaceous uplift of the country until now. At first a shallow sea or large lakes probably occupied the central portions of Iran and allowed the deposition of the green shales. Later, as the great basin was broken into smaller basins, the larger bodies of water gave place to smaller ones, and these, under the influence of a dry climate, gave place to playas or shallow salt lakes where the prevailing deposits were reddish silts. Still the process of deepening the basins and decreasing their area went on, with the result that the green shales were more highly warped and the red deposits were also uplifted along the borders of the basin and were exposed to erosion. Meanwhile the superficial deposits which now cover the plains were laid down and the country assumed its present form. It is not to be supposed that every basin has gone through exactly the same process, or that a single process has everywhere taken place at the same time. Accidents have intervened. At Zorabad the damming of the Heri Rud formed a lake and greatly altered the course of events. At Sistan, and probably elsewhere, a series of lakes appears to have occupied the basin during the glacial period. Nevertheless the general course of events was a gradual progress from larger basins to smaller basins, and from sub-aqueous to subaerial deposition."

The report is well illustrated and its publication in this country cannot but help correct the too great reluctance of American geologists to depart, in their interpretation of the continental deposits of western America, from the traditional invoking of those processes which in the infancy of geology were the sole known agencies of change because they are the controlling ones in its birthplace. The English geologists in India and Persia long ago pointed out the magnitude and characteristics of the reproductive work of rivers, and of the changes going on in arid regions; and Mr. Huntington well observes that the likeness of the physical history in Central Asia and the western and southwestern portions of the United States is now and has been in the course of geological time very striking both in product and process.

J. B. W.

# COLLEGES NEED :

The Leuckart Zoological Wall-Charts.

The Zittel Palæontological Wall Charts  
and Keller Reconstructions of Ancient Life.

Our Improved Mineral and Rock Trimmer.

Common Minerals by the Pound.

Biological Laboratory Supplies.

Our Unsurpassed Special Dissections.

The Shaler-Davis-Harris Series of Physiographic Models and  
Photographs.

Our Geological Models and Relief Maps.

Beecher Restorations of Trilobite and Stylonurus  
and Models of Typical Brachiopods.

Clarke Restorations of Eurypterus and Hughmilleria.

Casts of Famous Inscriptions—Rosetta Stone, Black Obelisk,  
Deluge Tablets, etc.

Our Genetic Collection of Rocks.

Our Collection of Phenomenal Geology.

Penfield Goniometers, for laboratory and field use.

Our Regular College Collections of Fossils, Minerals, Rocks, and  
Invertebrate Animals.

---

*Send for catalogues or circulars of some of these.*

THEY WILL DOUBLE YOUR TEACHING EFFICIENCY.

---

**Ward's Natural Science Establishment,**

76-104 COLLEGE AVENUE, ROCHESTER, N. Y.

## CONTENTS.

	Page
ART. XX.—Development of Fenestella ; by E. R. CUMINGS. (With Plates V, VI, and VII).....	169
XXI.—Age of the Monument Creek Formation ; by N. H. DARTON .....	178
XXII.—Iodometric Determination of Aluminium in Alumin- ium Chloride and Aluminium Sulphate ; by S. E. MOODY	181
XXIII.—Secondary Origin of Certain Granites ; by R. A. DALY .....	185
XXIV.—Tychite, a New Mineral from Borax Lake, Califor- nia, and on its Artificial Production and its Relations to Northupite ; by S. L. PENFIELD and G. S. JAMESON	217
XXV.—Modification of Victor Meyer's Apparatus for the Determination of Vapor-Densities ; by B. J. HAR- RINGTON .....	225
XXVI.—New Lower Tertiary Fauna from Chappaquiddick Island, Martha's Vineyard ; by T. C. BROWN. (With Plate VIII) .....	229
XXVII.—Production of Radium from Uranium ; by B. B. BOLTWOOD .....	239

### SCIENTIFIC INTELLIGENCE.

*Geology*—Explorations in Turkestan with an account of The Basin of Eastern Persia and Sistan. Expedition of 1903, under the direction of RAPHAEL PUMPELLE, 245.

50570

VOL. XX.

OCTOBER, 1905.

Established by BENJAMIN SILLIMAN in 1818.

THE  
AMERICAN  
JOURNAL OF SCIENCE.

EDITOR: EDWARD S. DANA.

ASSOCIATE EDITORS

PROFESSORS GEORGE L. GOODALE, JOHN TROWBRIDGE,  
W. G. FARLOW AND WM. M. DAVIS, OF CAMBRIDGE,

PROFESSORS ADDISON E. VERRILL, HORACE L. WELLS,  
L. V. PIRSSON AND H. E. GREGORY, OF NEW HAVEN,

PROFESSOR GEORGE F. BARKER, OF PHILADELPHIA,

PROFESSOR HENRY S. WILLIAMS, OF ITHACA,

PROFESSOR JOSEPH S. AMES, OF BALTIMORE,

MR. J. S. DILLER, OF WASHINGTON.

FOURTH SERIES

VOL. XX—[WHOLE NUMBER, CLXX.]

No. 118.—OCTOBER, 1905.

WITH PLATE IX.

NEW HAVEN, CONNECTICUT.

1905

THE TUTTLE, MOREHOUSE & TAYLOR CO., PRINTERS, 123 TEMPLE STREET.

Published monthly. Six dollars per year, in advance. \$6.40 to countries in the Postal Union. Remittances should be made either by money orders, registered letters, or bank checks (preferably on New York banks).

# RARE MINERALS IN TON LOTS

Correspondence solicited with miners or consumers of the ores of

**Molybdenum**

**Tantalum**

**Thorium**

**Titanium**

**Tungsten**

**Uranium**

**Vanadium**

**Yttrium**

**Zirconium**

and other rare metals. Offers from producers should be accompanied by samples.

---

## SYSTEMATIC COLLECTIONS OF TYPICAL SPECIMENS

In sets of twenty-five up to fifteen hundred specimens. Prices \$5.00 upwards per set, the average price for students' specimens being about twenty cents. We have supplied the leading institutions for thirty years, having lately completed a single order for over 60,000 specimens. Our material is the accepted standard both as to correct labeling and high quality.

**Free Collection Catalog**, containing lists and illustrations of General Mineral Collections, Series of Ores for Prospectors, Sets of Crystals, Series illustrating Hardness and other Physical Characters of Minerals, with Price List of Laboratory Material and Individual Specimens.

---

## FOOTE MINERAL CO.,

Established 1876, by Dr. A. E. Foote.

**W. M. FOOTE**, Manager.

DEALERS IN

MINERAL SPECIMENS AND COMMERCIAL RARE MINERALS,  
1317 Arch Street, Philadelphia.



T H E

# AMERICAN JOURNAL OF SCIENCE

[FOURTH SERIES.]

---

ART. XXVIII.—*On the Ultimate Disintegration Products of the Radio-active Elements*; by BERTRAM B. BOLTWOOD.

IN a paper by Rutherford and Soddy,\* the authors have called attention to the probability that an intimate knowledge of the composition of radio-active minerals will lead to the recognition and identification of the ultimate, stable products formed by the disintegration of the relatively unstable radio-active elements.†

It is an extremely impressive fact that it was from the somewhat meager information available on the occurrence of helium in radio-active minerals, and from the consideration of the data derived from the experiments of one of them on the nature of the expelled alpha particle, that in 1902 the same authors were enabled to make that brilliant prediction of the production of helium‡ which was afterwards confirmed by the experiments of Ramsay and Soddy.

The natural minerals represent chemical systems which are in most instances of extreme antiquity, their original formation having frequently taken place during the earliest geological periods of our planet. With the assistance of the data supplied by geology and mineralogy, it is often possible to assign the origin of a given mineral to some definite geological period and to arrange a series of different individuals roughly in the order

\* Phil. Mag. (6), v, 576 (1903).

† "In the naturally occurring minerals containing the radio-elements these changes must have been proceeding steadily over very long periods, and, unless they succeed in escaping, the ultimate products should have accumulated in sufficient quantity to be detected, and should therefore appear in nature as the invariable companions of the radio-elements."—*Rutherford and Soddy, loc. cit.*

‡ Phil. Mag. (6), iv, 582.

of their production, obtaining in this manner an approximate knowledge of their relative ages. In dealing with the question of radio-active change, where the element of time is such an important factor in the solution of nearly every problem, the advantages to be derived from the careful study of the radio-active minerals can therefore scarcely be overestimated.

From a knowledge of the chemical properties and the crystallographic, optical and other physical properties of a given mineral specimen, together with an understanding of its occurrence and of the other mineral substances with which it is found associated, it is generally possible to definitely determine whether the mineral was formed simultaneously with the mass of material or geological formation in which it now occurs, or whether it is of more recent production, having originated through the action of percolating waters or of subterranean vapors or gases on some original constituent. In the former case, when all available data indicate that the formation of the mineral was coincident with that of the mass of rock in which it occurs, the mineral can be classed as primary; in the latter case, when it has apparently originated through the alteration of primary compounds, it can be considered as secondary. The term secondary can also be applied in a restricted sense to such minerals as occur in veins, where the general character of the vein indicates that it has originated through the formation of fissures in existing strata and that the contents of the vein is of an age inferior to that of the mass of rock by which it is bounded.

In applying these considerations to the greater number of minerals which have up to this time been observed to contain radio-active constituents, it may be considered as fortunate that these minerals occur under conditions which would seem to render the task of assigning the individual species to one or the other of the above classes a relatively simple one.

The most prominent radio-active mineral, uraninite, more commonly known as pitchblende, occurs both as a primary constituent of granitic rocks and also as a constituent of metalliferous veins cutting geological formations of a relatively recent geological period. When occurring in a granitic rock the uraninite is frequently quite perfectly crystalline in form and the rock itself is of the type called pegmatite; the most noted localities furnishing specimens of this primary uraninite being southern Norway, particularly in the neighborhood of Moss, North Carolina, Llano Co., Texas, and Connecticut. Prominent localities where uraninite occurs as a constituent of metalliferous veins are Johanngeorgenstadt, Marienberg and Schneeberg in Saxony, Joachimsthal and Příbram in Bohemia, Cornwall in England, and Colorado and South Dakota in the United States.

The term secondary uraninite will be used in referring to the material from these latter localities.\*

Among the radio-active minerals other than uraninite which occur as primary constituents of pegmatite may be mentioned thorite, samarskite, fergusonite, aeschynite, euxenite, monazite and the recently described† thorianite. Associated with, and obviously resulting from the alteration of, the primary minerals through the action of percolating waters and other agencies, are secondary minerals, the more prominent of which are gummite, thorgummite, uranophane and autunite.

In considering the available data on the composition of radio-active minerals, with a view to discovering the ultimate disintegration products of the radio-elements, it is therefore necessary to give strict attention to the question of the primary or secondary origin of the individual specimens and the geological period at which they were formed. The nature of the associated minerals is also usually of considerable significance, since through them it is frequently possible to discover some clue to the conditions under which the mineral originated and some indication of the influences to which they have been subjected since they were first formed.

#### *Lead.*

In reviewing the various published analyses of minerals containing notable proportions of uranium, and particularly of those which are evidently of primary origin, one can not fail to be impressed by the frequent and almost invariable occurrence of lead as one of the other constituents. Out of a considerable number of analyses undertaken with the particular object of discovering whether or not lead was present, I have been unable to find a single specimen of a primary mineral containing over two per cent of uranium in which the presence of lead could not be demonstrated by the ordinary analytical methods. The same is moreover true of the secondary uranium minerals which have been examined, although in a single case, namely in a small specimen of uranophane from North Carolina, the proportion of lead was so low as to require the working up of a gram of material in order to conclusively demonstrate the presence of lead as a constituent.

Through a dawning appreciation of the significance of the persistent appearance of this element in uranium minerals, the writer was led to suggest in an earlier paper‡ that lead might prove to be one of the final, inactive disintegration products of uranium. All the data which have been obtained since that time point to the same conclusion.

\* Hillebrand, this Journal, xi, 384 (1890).

† Dunstan and Blake, Proc. Roy. Soc. Lond. (A), lxxvi, 253 (1905).

‡ Phil. Mag. (6), ix, 613 (1905).

I have been particularly impressed by the information kindly supplied in a private communication by Mr. W. F. Hillebrand of the U. S. Geological Survey, a recognized authority on the analysis of uranium minerals, that so far as his experience goes he does not remember to have found uranium in any mineral without its being accompanied by lead, and he adds: "the association has often caused me thought."

Additional weight attaches to these experimental indications because of the theoretical considerations leading to a similar conclusion. It has been pointed out by Rutherford,\* that if the alpha-ray particle consists of helium, since four alpha-ray products intervene between radium and the final, inactive substance radium-G, the indicated atomic weight of radium-G is sufficiently near to that of lead to be impressive. Thus one alpha particle is expelled by each of the atoms Ra, Ra-Em, Ra-A, Ra-C and Ra-F, making five particles in all. The loss of five alpha particles with an atomic weight of 4 from the atom of radium with an atomic weight of 225 would cause a reduction of this by  $4 \times 5 = 20$  units, with the formation of a chemical element having an atomic weight of 205 or thereabouts. This is not far from the accepted atomic weight of lead, namely 206.9.

#### *Thorium (Rare earths).*

Another element which occurs quite commonly with uranium is thorium, and the common association of these two elements has been noted by Strutt and interpreted by him as indicating that thorium is possibly the parent of uranium.† Aside from the very doubtful hypothesis that the atomic weight of thorium is greater than that of uranium, his conclusions would seem open to serious objections. His statement that all thorium minerals contain readily detectable quantities of uranium, while some minerals containing notable quantities of uranium are comparatively free from thorium, is manifestly in accord with his experimental data, but it would appear that his thorium minerals containing uranium are all old minerals, while his uranium minerals containing no thorium are of relatively recent origin. If his theory is correct, the existence of very old minerals containing high percentages of uranium and no thorium should be possible, but that such minerals have been found is not indicated by any of the reliable analyses available. The experimental data offered by Strutt, as well as those to be derived from other sources, can all be much more consistently interpreted by the assumption that thorium is a disintegration product of uranium having a life considerably longer than that

\* Silliman Lectures, Yale University, 1905. Not yet published.

† Proc. Roy. Soc. Lond. (A), lxxvi, 88 (1905).

of its parent and long as compared with the oldest of the known minerals. This hypothesis is supported by the circumstance noted by Strutt, that in general the minerals containing high proportions of thorium also contain a comparatively high proportion of helium, a point which will be referred to later in the course of this paper. Since the present knowledge of radio-active phenomena leads to the assumption that the average life of uranium is of the order of  $2 \times 10^9$  years, while the average life of thorium is apparently in excess of that number, it seems scarcely reasonable to expect that minerals will be found which are sufficiently old for a state of equilibrium to have been reached between thorium and uranium. The production of a slowly changing disintegration product from a more rapidly changing parent is in no way contradictory to the disintegration theory, since a number of examples of this are at present recognized.\* The common association of the other rare earths with thorium may indicate, as suggested by Strutt, that these are possible final products of the latter element.

#### *Bismuth.*

The occurrence of bismuth as a constituent of the more highly radio-active minerals is another significant indication of a possible end product. The proportion of bismuth which is present in the older radio-active minerals is, however, very small, so small indeed that its occurrence is but seldom detected in the ordinary course of analysis. It is only in treating considerable quantities of material for the extraction of polonium that the presence of bismuth becomes evident. This occurrence of bismuth in small quantities is suggestive of its formation from the disintegration, either of a parent having a relatively long life, or of one which is itself produced in only relatively small quantities. The former requirement would seem to be fairly well filled by thorium, in which case it is to be expected that in two minerals of equal age, the one containing the greater proportion of thorium would also contain the greater relative amount of bismuth. An opportunity has not yet been found for the experimental investigation of this question. The fact that the atomic weight of bismuth differs from the atomic weight of thorium by exactly 24 units, an even multiple of 4, is possibly significant.

#### *Barium.*

Another element which persistently appears as a minor constituent of uranium minerals is barium. Its production, if it is

\* One example is the production of the active deposit from the thorium emanation, the parent with a half-value period of less than one minute, the product with a half-value period of eleven hours.

actually a disintegration product, is certainly slow, for only very small relative amounts of it are found in some comparatively old minerals. In primary minerals the amount of lead present is always greatly in excess of the barium, which occurs only in traces made evident in the separation of the radium from considerable quantities of material. As in the case of bismuth, the barium might be produced either from a slowly disintegrating parent or from a radio-active body existing only in comparatively small amounts in the radio-active system. Certain data, to be published later by the writer, have been obtained which seem to indicate that the amount of actinium in a radio-active mineral is dependent on the amount of uranium present, thus suggesting that uranium is the parent of actinium as well as of radium, but other results lead to the conclusion\* that actinium is not a direct result in the same sense as is radium. The quantity of actinium produced in a radio-active mineral is apparently small as compared to the radium, and it may therefore be possible that the barium present is a final product of the actinium.

#### *Hydrogen.*

A point which has caused much speculation on the part of mineralogists is the apparent hydration of the greater number, if not all, of those minerals which are now known to contain radio-active constituents. That this state of affairs is in some way connected with the disintegration processes taking place in these compounds would not appear impossible, since the production of such an elementary substance as hydrogen as one of the products of the radio-active decay of the atoms of elements of high atomic weight is in fact suggested by much of the data on the nature of the expelled alpha particles.† It would seem possible that the difference in ionizing power, of the power of penetration, etc., shown by the alpha particles from certain of the radio-active types of material may perhaps be due to a difference in the mass of the projected particle, and that the occurrence of notable quantities of water in the primary radio-active minerals, which is otherwise most difficult to explain, may be considered as indicating that hydrogen is in fact one of the disintegration products, originating as an alpha-ray particle from one or more of the numerous radio-active substances which have already been identified. The origination of hydrogen in a mineral containing oxidized constituents would in all probability lead to the reduction of the more readily reducible of these with the consequent production of water.

\* Rutherford and Boltwood, this Journal, xx, 56 (1905).

† Rutherford, "Radio-activity," p. 328 and elsewhere.

In the greater number of instances where water is found present in these minerals, it is quite impossible to explain how it could have penetrated into them from without, since their close-grained and impervious nature is impressively indicated by the very notable quantity of helium which they have retained. Moreover non-radio-active minerals which occur associated with the radio-active species, and which have been subjected to the same external influences, are often quite anhydrous, e. g., apatite, magnetite, etc. The mineral thorite has been called to the attention of the writer by Professor S. L. Penfield. This mineral frequently occurs in very perfect crystals, which however exhibit only the optical properties of an isotropic and amorphous compound. This species has been long regarded as having undergone alteration, but that the causes of the alteration existed within and not without the crystals is, I believe, a new and somewhat novel explanation.

It is a significant fact that results obtained\* in the examination of certain radio-active minerals indicate that hydrogen occurs as one of the gaseous constituents of many of these compounds. A further interesting point bearing on this question is mentioned by Hillebrand,† who observed that when uraninite was mixed with sodium carbonate and fused in an atmosphere of carbon dioxide, the lead present was apparently entirely reduced and collected in globules. Mixtures of corresponding proportions of lead oxide (litharge) and  $U_3O_8$  or  $UO_2$ , when treated in an identical manner, showed no reduction of the litharge to metallic lead. This distinctive difference in behavior is strongly indicative of the presence of hydrogen as a constituent of uraninite.

#### *Argon.*

Results obtained by Ramsay and Travers‡ may further indicate that another of the disintegration products of radio-active substances is the inert gas argon. It is stated by these authors that most minerals which evolve helium also evolve argon in small quantity. It may not be impossible that some of the rayless changes which have been observed by Rutherford to take place in radio-active bodies, may be accompanied by the expulsion of alpha particles consisting of argon, which owing to their relatively high mass are projected at too low velocities to cause ionization of the surrounding gases and to permit

\* Ramsay, Collie and Travers, *Jour. Chem. Soc., Lond.*, lxvii, 684 (1895), state that hydrogen in varying quantities was evolved by yttrantalite, samarskite, hielmite, fergusonite, tantalite, monazite, xenotime, columbite, perofskite, euxenite, orthite, gadolinite and cerite. Also Ramsay, *Proc. Roy. Soc. Lond.*, lix, 325 (1896).

† *Bulletin of the U. S. Geological Survey*, No. 78, p. 59 (1891).

‡ *Proc. Roy. Soc. Lond.*, lii, 316 (1898).

their detection by the ordinary electrical methods. It has been pointed out by Rutherford\* that the kinetic energy of certain alpha particles approaches quite closely to the critical value below which no ionization would be produced. It is moreover quite interesting that the assumption of a difference of atomic mass of 40 units between certain successive radio-active transformation products would greatly facilitate their assignment to vacant positions in the periodic system of the elements.

### Composition of Uraninite.

The suggestions offered in the foregoing pages as to the possible nature of some of the disintegration products resulting from the process of radio-active change can be more clearly understood, and the basis of fact from which they have been derived can be more correctly appreciated, by a consideration of some of the results which have been obtained in the analysis of radio-active minerals.

The most accurate and reliable of the available data on the composition of uraninite have been published by Hillebrand.†

TABLE I.

Locality Number.	Glastonbury, Conn.					Branchville, Conn.			Colo.	N. Carolina.	
	I	II	III	IV	V	VI	VII	VIII	IX	X	XI
UO <sub>3</sub>	22·08	23·35	22·22	26·48	23·03	13·27	21·54	14·00	25·26	50·83	44·11
UO <sub>2</sub>	59·13	58·01	59·31	57·43	59·93	72·25	64·72	70·99	58·51	39·31	46·56
Total Uranium	70%	70	70	72	72	74	75	74	72	77	77
PbO	3·14	3·24	3·07	3·26	3·08	4·35	4·34	4·35	0·70	4·20	4·53
ThO <sub>2</sub>	----	----	----	9·79	----	7·20 <sup>2</sup>	6·93	6·52 <sup>2</sup>	0·0	2·78	----
Total rare earths	9·57	10·24	10·31	10·37	11·10	7·20	7·26	6·52	7·81	3·74	3·04
N <sub>2</sub> <sup>1</sup>	----	----	----	----	2·41	----	----	2·63	0·15	0·37	----
H <sub>2</sub> O	0·97	----	----	0·61	0·43	0·68	0·67	0·68	1·96	1·21	----
Sp. G.	9·12	9·05	----	9·58	9·62	9·73	9·56	9·35	8·07	9·08	9·49

Various important details such as the general character and appearance of the different samples and the indication of alteration from external causes in a number of specimens will be found in Hillebrand's papers.

Blank spaces in the table signify that the indicated constituent was not determined.

<sup>1</sup> Hillebrand assumed that the inert gas present was nitrogen and the percentages of this element shown in the table are calculated on the basis of that assumption. By dividing these numbers by 7 a maximum value for the helium separated is obtained.

<sup>2</sup> ThO<sub>2</sub> + ZrO<sub>2</sub> ?

The results of his analyses are given in a condensed form in Table I.

\* Phil. Mag., July (1905).

† Bulletin of the U. S. Geological Survey, No. 78, p. 43, 1891; this Journal, xl, 384 (1890); *ibid.*, xlii, 390 (1891).



Neglecting for the present the results under IX and XXII, which are types of secondary uraninites, it will be noticed in an examination of the numbers given in Table I that—

1. In specimens from the same general locality, viz.: from Connecticut, from Norway and from North Carolina, a rough proportionality is shown between the content of uranium and the content of lead, rare earths, helium (nitrogen) and water. A still more striking relation appears to exist between the proportion of uranium in the form of the lower oxide,  $UO_2$ , and the amount of helium (nitrogen). This was remarked by Hillebrand, who makes the following statement\* in connection with the results obtained from the analysis of the first eighteen samples:

“Throughout the whole list of analyses in which nitrogen has been estimated the most striking feature is the apparent relation between it and the  $UO_2$ . This is especially marked in the table of Norwegian uraninites recalculated†, from which the rule might almost be formulated that, given either nitrogen or  $UO_2$ , the other can be found by simple calculation. The same ratio is not found in the Connecticut varieties, but if the

TABLE I.

Norway.							Texas.	S. Carolina.	Canada.	Saxony.
XII	XIII	XIV	XV	XVI	XVII	XVIII	XIX	XX	XXI.	XXII.
30.63	25.36	22.04	32.00	35.54	42.71	26.81	44.17	----	41.06	59.30
46.13	50.74	43.03	43.88	43.38	24.18	44.18	20.89	----	34.67	22.33
66	66	57	65	68	56	61	55	71	65	68
9.04	10.06	8.58	9.46	9.44	10.54	10.95	10.08	3.58	11.27	6.39
6.00	8.48	----	8.98	6.63	----	4.15	6.39	1.65	6.41	0.0
7.62	9.03	8.43	10.48	8.09	13.42	13.87	19.19	10.25	10.49	0.0
1.17	1.28	1.08	1.03	1.08	----	1.24	0.54	----	0.86	0.02
0.74	0.73	0.74	0.77	0.79	1.23	----	1.48	----	1.47	3.17
8.89	9.14	8.32	8.96	8.93	7.50	----	8.29	----	----	6.89

Of the samples from Norway XII was from Anneröd, XIII and XIV from Elvestad, XV from Skaartorp, XVI from Huggenäsken, and XVII and XVIII from Arendal. Sample XIX was from Llano Co., Texas, XX from Marietta, South Carolina, XXI from Villeneuve, Canada, and XXII from Johannegeorgenstadt, Saxony.

determination of nitrogen in the Branchville mineral is to be depended on, the rule still holds that the higher the  $UO_2$  the higher likewise is the nitrogen. The Colorado and North Carolina minerals are exceptions, but it should be borne in mind that the former is amorphous like the Bohemian and possesses the further similarity of containing no thorium, although zirconia may take its place, and the North Carolina material is

\* This Journal, xi, 391 (1890).

† Excluding the insoluble matter.

so much altered that its original condition is unknown." This generalization can apparently be extended to include lead also.

2. When the analyses of samples from the same actual locality are compared it will be evident that, in general,

a) The content of rare earths increases with the amount of lead present. This is most strikingly shown in the groups I-V, VI-VIII, XIII-XIV and XVII-XVIII. The simultaneous variation of thorium is also indicated somewhat imperfectly in those instances where this constituent was separately determined.

b) That in those specimens having the highest specific gravity (v and viii) the proportion of helium compared with the lead present is greatest. It is in general to be expected that the denser and therefore less porous material would retain a greater proportion of the helium formed within it. The low proportion of gas compared with lead in x and xix might well be due to the high emanating power of the former\* and the greater porosity of the latter indicated by its low density. It is moreover interesting to note that those specimens (x, xix, xxi) containing disproportionately large amounts of water contain a relatively low amount of helium compared with the lead present. It is possible that these minerals were sufficiently porous to permit the entrance of water from without while at the same time a part of the helium formed has escaped from within them.

It is evident that, in Table I, a lack of agreement exists between the proportion of lead and rare earths and the proportion of helium in the Connecticut material and the proportions of the corresponding constituents in the Norwegian samples. In the latter the amounts of lead and rare earths as compared with the gas present are much greater than in the former. This can be explained by assuming that the Norwegian minerals are considerably older than the American varieties, and that the Norwegian specimens examined by Hillebrand have in some manner lost a large part of their helium. The geological data available on the relative ages of the American and Norwegian occurrences, while not entirely in accord with the assumption of such a great difference in age, would not appear to be sufficiently definite to preclude such a possibility.

In considering the bearing of the results of the analyses of the two secondary uraninites, ix and xxii, on the general theories proposed in this paper, it is evident that the presence

\* *Phil. Mag.* (6), ix, 609.

of the low proportion of lead and helium, and the practical absence of thorium in IX, is quite in accord with the geological indications that this material is of an age greatly inferior to that of the primary uraninites. In XXII the very notable amount of lead shown by the analysis would seem to offer no serious obstacle to the theory, since this material occurs intimately associated with the sulphide of lead and other similar minerals, and the massive and amorphous form in which it is found would indicate that the conditions under which it was originally deposited were not favorable to the separation of a pure uranium compound. The statement of Hillebrand\* that nitrogen (helium) and the rare earths were practically absent in specimens of secondary uraninite from Příbram, Joachimsthal and Johanngeorgenstadt; which he examined, is also of interest in this connection. The experience of Debièrnet† in separating actinium from a secondary uraninite of this character, is, however, indicative of the existence of small amounts of thorium in these minerals.

*Other Radio-active Minerals.*

In the table which follows (Table II) will be found some data compiled from various sources on the composition of a number of primary and secondary radio-active minerals.

As bearing on the topic under discussion it is interesting to note the following :—

1. The greatest proportion of helium with respect to the uranium and lead present has been observed in those primary minerals which have the lowest emanating power and the highest specific gravity, i. e., in the most compact and least porous minerals. Examples are furnished by thorianite, fergusonite, samarskite and monazite. (Of the varieties of thorite, much greater proportions of helium have been observed in the variety known as orangite, which has also the greatest density.)

2. Greater proportions of lead and helium with respect to uranium are found in those primary minerals which occur in the oldest geological formations. This point is well illustrated by thorianite, which is found in Ceylon in a geological formation which is probably of the Archean period.

3. The primary minerals containing the greatest proportion of thorium are in general the most hydrated.

In considering the secondary radio-active minerals certain probable conditions must be recognized. Where these minerals are formed by the alteration of primary minerals *in place*, namely, where the primary mineral is acted on by underground

\* Bulletin U. S. Survey, No. 78, p. 72.

† Compt. rend., cxxx, 906 (1900).

TABLE II.

PRIMARY MINERALS.							Reference.
Species.	Locality.	ThO <sub>2</sub>	UO <sub>2</sub>	PbO	H <sub>2</sub> O	He	
Thorite, Hitterö, Norway	----	48.66	9.00 <sup>1</sup>	1.26	10.88	X <sup>a</sup>	Dana, p. 488
Mackintoshite, Llano Co., Tex.	----	45.30	22.40	3.74	4.31	X <sup>b</sup>	A <sub>1</sub>
Yttrialite, Llano Co., Tex.	----	10.85	1.64	0.80	0.32	X <sup>c</sup>	A <sub>2</sub>
Thorianite, Ceylon	----	78.86	----	2.59	X <sup>d</sup>	0.39%	A <sub>3</sub>
Samarskite	----- <sup>3</sup>	10-13%	----	----	3-1%	X <sup>e</sup>	
"	(?) Colorado	3.64	4.02	0.72	1.58	?	Dana, p. 740
Annerödite, Anneröd, Nor.	----	2.37	16.28	2.40	8.19	.?	Dana, p. 741
Euxenite	----- <sup>3</sup>	5-12%	0.92	4.71	?		Dana, p. 744
Hielmite, Falun, Sweden	----	?	2.34 <sup>4</sup>	0.21	2.23	X <sup>e</sup>	Dana, p. 742
Polycrase, Slättakra, Nor.	----	3.51	18.45	0.92	4.71	X <sup>e</sup>	Dana, p. 745
Fergusonite, Llano Co., Tex.	----	0.83	7.05 <sup>5</sup>	1.43	2.02	?	Dana, p. 730
"	--	?	3.81 <sup>4</sup>	0.16	?	0.03	A <sub>4</sub>
Xenotime, Narestö, Sweden	----	2.43	3.48 <sup>4</sup>	0.68	1.77	X <sup>e</sup>	Dana, p. 749
Monazite, North Carolina	----	5.00	0.40 <sup>6</sup>	tr.	0.20	X <sup>e</sup>	

## SECONDARY MINERALS.

UO <sub>3</sub>							
Gummite, North Carolina	----- <sup>7</sup>	75.20	5.57	10.54	?		Dana, p. 892
Thorogummite, Llano Co., Tex.	----	41.44	22.43	2.16	7.88	?	A <sub>5</sub>
Carnotite, Colorado	-----	0.0	52.25	0.25	3.06	0 <sup>8</sup>	A <sub>6</sub>
Uranophane, North Carolina	---- <sup>9</sup>	66.67	0.60	12.02	?		Dana, p. 699

<sup>1</sup> U<sub>2</sub>O<sub>3</sub>.<sup>2</sup> UO<sub>3</sub> 6.03 + UO<sub>3</sub> 9.07.<sup>3</sup> Hofmann and Strauss (Berichte, xxxiii, 3126) state that they found both thorium and lead in samarskite and in euxenite.<sup>4</sup> UO<sub>3</sub>.<sup>5</sup> UO<sub>3</sub> and UO<sub>2</sub>.<sup>6</sup> The composition of monazite given above is derived from experiments of the writer.<sup>7</sup> Specimens of gummite from North Carolina analyzed by the writer have been found to contain from 2 to 3 per cent. of thoria.<sup>8</sup> It is stated by Adams (this Journal, xix, 321 (1905) that helium is absent from this mineral, which is to be expected since it is highly porous and of recent formation.<sup>9</sup> Samples of this material have been examined by the writer in which no thorium could be detected.X<sup>a</sup> Helium has been found in the variety of thorite known as orangite.X<sup>b</sup> Hillebrand's experiments suggest the presence of helium in this mineral.X<sup>c</sup> Including this species among the primary minerals is possibly open to objection. Hillebrand's experiments would seem to indicate that it contains from 1<sup>cc</sup> to 2<sup>cc</sup> of helium per gram.X<sup>d</sup> The analyses of Dunstan and Blake (see Ref.) do not indicate the presence of water, but several tests made by the writer, on samples kindly supplied by Mr. Geo. F. Kunz, suggest the presence of water in quite notable quantities.X<sup>e</sup> The occurrence of helium in samarskite, hielmite, polycrase, xenotime, monazite, orangite, and other radio-active minerals is described in papers by Ramsay, Collie and Travers (Jour. Chem. Soc. Lond., lxvii, 684) and Ramsay and Travers (Proc. Roy. Soc. Lond., lx, 442).A<sub>1</sub> W. F. Hillebrand, this Journal, xlvi, 101 (1893).A<sub>2</sub> Hillebrand, this Journal, xiii, 195 (1902).A<sub>3</sub> Dunstan and Blake, Proc. Roy. Soc. Lond. (A), lxxvi, 253 (1905).A<sub>4</sub> Ramsay and Travers, Proc. Roy. Soc. Lond., lii, 316 (1898).A<sub>5</sub> Hillebrand and Mackintosh, this Journal, xxxviii, 480 (1889).A<sub>6</sub> Hillebrand and Ransome, this Journal, x, 120 (1900).

waters, etc., with the removal of certain constituents and the substitution of others originally dissolved in the waters, the resulting hydrated residue will in some cases consist of a mixture of several different chemical compounds and its general composition will not correspond to any definite formula, but will depend on chance and the accidental local conditions. An excellent example of a secondary product of this character is afforded by the mineral known as gummite, which occurs as an alteration product of the North Carolina uraninites. Samples of this mineral from the Flat Rock mine have been examined by the writer, in which great variations in the proportions of lead, thorium and uranium present were observed in samples removed from different parts of the same comparatively small specimen. The mineral known as uranophane from the same locality shows corresponding variations in composition. Both these substances are amorphous in structure but very frequently occur with a crystalline form as pseudomorphs after the original uraninite. It is obvious that these facts must be considered in attempting to arrive at any conclusions from a chemical examination of these materials.

In other cases the percolating waters undoubtedly dissolve the more readily soluble components of the primary minerals and deposit them again as definite, crystalline compounds of a relatively high degree of purity. Examples of this sort are afforded by such minerals as torbernite  $[\text{Cu}(\text{UO}_2)_2\text{P}_2\text{O}_8 \cdot 8\text{H}_2\text{O}]$ , autunite  $[\text{Ca}(\text{UO}_2)_2\text{P}_2\text{O}_8 \cdot 8\text{H}_2\text{O}]$ , uranocircite  $[\text{Ba}(\text{UO}_2)_2\text{P}_2\text{O}_8 \cdot 8\text{H}_2\text{O}]$ , zeunerite  $[\text{Cu}(\text{UO}_2)_2\text{As}_2\text{O}_8 \cdot 8\text{H}_2\text{O}]$ , uranosphaerite  $[(\text{BiO})_2\text{U}_2\text{O}_7 \cdot 3\text{H}_2\text{O}]$ , and a considerable number of others. The examination of minerals of this character will probably afford data of considerable value on the nature of the ultimate disintegration products of uranium.

The mineral mackintoshite is quite possibly of secondary origin, but owing to some doubt in the matter it has been placed among the primary minerals. It may represent a variety of thorite, containing originally a considerable proportion of uranium, which has undergone alteration owing to the radio-active processes which have taken place within it. The evidence is strongly in favor of the view that the thorogummite has been formed from the alteration of the mackintoshite through external causes.

Any definite conclusions at present as to the formation of carnotite are quite impossible. Its composition and occurrence are both so unique that little or no analogy with other known uranium compounds can be detected. It seems highly probable, however, that its age is not relatively very great and its general composition, *e. g.* the low amount of lead present and the practical absence of thorium and helium, is quite in accord with such a conclusion.

An interesting radio-active mineral has been described by Danne.\* This substance is stated to be a phosphate of lead, or pyromorphite, containing quantities of radium equivalent to about 6 per cent of uranium. It is asserted, however, that no uranium is present in the mineral, although considerable deposits of uranium minerals are known to exist at no very great distance in the same region where it occurs. According to Danne, the pyromorphite is found in fissures through which underground waters containing radium salts are constantly percolating, and he suggests that the radium contained in the mineral is derived from the water. It might also be conjectured that the lead of the mineral has resulted from the disintegration of radium, the radium itself having been formed from the disintegration of uranium in the neighboring deposits.

#### *Occurrence of Minerals.*

It would seem possible that some general data on the disintegration products of radio-active substances might be derived from the study of the conditions under which the radio-active minerals occur in nature. The following suggestions may perhaps be of interest in this connection. The primary minerals found in the pegmatitic dikes include uraninite, thorite, fergusonite, aeschenite, euxenite, columbite and monazite, all of which, with the exception of columbite,† probably contain thorium in greater or smaller proportions. The theory generally accepted by geologists is that the pegmatites were formed under conditions of so-called hydro-igneous fusion, involving high temperatures and the presence of considerable water vapor which was prevented from escaping by the high pressure due to incumbent masses of rock of great thickness. Assuming the prior existence of considerable deposits of uranium compounds at great depths, it would appear probable that in an upheaval of deep-lying material, with the intrusion of the plastic magma into the upper layers from below, the conditions would be favorable to the separation of the various constituents of the already partially disintegrated uranium with the production of new minerals representing new combinations of the various elements present. Thus some of the uranium might separate out as the oxide (uraninite), either quite free from other elements or with admixtures of other isomorphous oxides (thorium oxides and other rare earth oxides), while the thorium might be greatly concentrated in the form of such minerals as thorite and thorianite, containing mixtures of variable propor-

\* Compt. rend., cxi, 241 (1905).

† The very common association of radio-active elements with niobium, tantalum, etc., in minerals is possibly significant of some ultimate relation between them.

tions of uranium and the rare earths. Others of the rare earths present might be themselves concentrated to form such minerals as allanite and gadolinite, compounds containing but relatively small proportions of the radio-elements.

When uraninite is found in metalliferous veins the general indications point to its transportation hither from greater depths by thermal waters and its deposition at a temperature considerably lower than that existing in the plastic pegmatite. The association of the secondary uraninites with the sulphides of iron, copper, lead, bismuth and other metals is indicative of conditions of deposit unfavorable to the simultaneous production of rare earth minerals, which have never been observed to occur under similar conditions in any locality.

The mode of occurrence of radio-active minerals would therefore appear to offer certain valuable data on the processes taking place in the radio-elements and the products formed by their disintegration.

#### *Origin of Elements.*

If it can be ultimately demonstrated that lead, bismuth, barium, hydrogen and argon, or any one of them, actually result from the disintegration of uranium, an interesting question which naturally arises will be: Have the quantities of these chemical elements already existing been produced wholly in the same manner? Any discussion of this problem at the present time would certainly be premature, but the time may not be very far remote when this question will deserve serious consideration.

#### *Summary.*

Various data have been presented which are interpreted as indicating that the ultimate disintegration products of the radio-elements may include lead, bismuth, barium, the rare earths, hydrogen and argon.

The writer is fully conscious of the meagerness of the data upon which the hypothesis of the production of these substances is founded, but the suggestions are made in the hope that the attention of other investigators may be directed to the possibilities offered by a careful study of the composition and occurrence of the radio-active minerals, and that their interest may be sufficiently awakened to induce them to independently undertake the experimental investigation of the theories which have been suggested.

ART. XXIX.—*The Use of the Rotating Cathode for the Estimation of Cadmium taken as the Sulphate*; by CHARLES P. FLORA.

[Contributions from the Kent Chemical Laboratory of Yale Univ.—cxxxix.]

IN a recent paper from this laboratory\* has been described the application of the rotating cathode to the rapid estimation of copper, silver and nickel; and, in a later paper,† its fitness for the estimation of cadmium as well as several other metals has been shown. The object of the present investigation has been to more thoroughly study the conditions under which cadmium may be estimated by this means. The apparatus used was that described in the previous papers. Since it had already been shown‡ that cadmium taken in the form of the sulphate can be estimated by deposition of a solution slightly acidulated with sulphuric acid, this formed the natural point of departure.

I. *In Solutions containing Sulphuric Acid.*

A solution of cadmium sulphate was prepared, containing approximately 16.6 grams of the salt to the liter of water. Portions of this solution were carefully measured from a burette, diluted to the desired volume, a few drops of dilute sulphuric acid (1:4) added, the proper connections made and the electrolysis conducted as previously described. The following were the results obtained upon two different solutions:

SOLUTION A.							
No. of Exp.	Sol. taken. cm <sup>3</sup> .	H <sub>2</sub> SO <sub>4</sub> . (1:4) drops.	Time. min.	Cur't read.= amp.	N.D. <sub>100</sub> amp.	E.M.F. approx. volts.	Cd. found gm.
1.	15	5	18	0.4-1.0	1.2-3.0	8	0.1111
2.	15	5	10	0.4-0.5	1.2-1.5	8	0.1090
3.	15	5	16	0.4-0.9	1.2-2.7	8	0.1115
4.	15	7	35	0.5-1.0	1.5-3.0	8	0.1117
5.	15	12	25	1.0-1.5	3.0-4.5	8	0.1115
6.	15	10	35	1.0-1.5	3.0-4.5	8	0.1120
7.	15	18	30	1.5-2.0	4.5-6.0	8	0.1119
8.	15	15	25	1.5-2.0	4.5-6.0	8	0.1117
9.	30	Indef.	15	3.0-4.0	9.0-12.0	8	0.2235
10.	20	12	35	2.0-3.0	6.0-9.0	8	0.1491
11.	15	Indef.	60	2.0	6.0	8	0.1120

In experiments numbered 1 to 4, the liquid at the end of the period indicated showed traces of cadmium remaining, but in the seven experiments following these the cadmium was all deposited upon the cathode in a satisfactory condition. These

\* Gooch and Medway, this Journal [4], 320 (1903).

† Medway, this Journal [4], xviii, 56 (1904).

‡ Loc. cit.



results were therefore taken as indicating the standard of the solution used, the mean of the series showing the presence of 0.007454 gram. of cadmium in each cubic centimeter of the solution.

In a second solution which it became necessary to standardize the following results were obtained :

SOLUTION B.						
No. of Exp.	Sol. taken. cm.	Time. min.	Cur't read. = amp.	N.D <sub>100</sub> amp.	E.M.F. vts.	Cd. found. gm.
1.	20	27	1.0-1.5	3.0- 4.5	7.9	0.0816
2.	25	30	2.0-3.0	6.0- 9.0	7.9	0.1018
3.	25	55	2.5-4.0	7.5-12.0	7.6	0.1019
4.	30	25	2.0-2.5	6.0- 7.5	12.0	0.1224
5.	30	20	1.0	3.0	7.8	0.1223
6.	30	10	1.5-2.5	4.5- 7.5	7.8	0.1226

The mean of these six experiments gives a value of 0.10194 gram. of cadmium for every 25<sup>cm<sup>3</sup></sup> of the solution, or 0.0040776 gram. for each cubic centimeter. This value was taken as the standard whenever this solution was used.

One point which was not mentioned in the former paper\* on the estimation of cadmium by this method, but which is of much importance, is that of dilution. The earlier experiments in this work were performed at a dilution of from 65<sup>cm<sup>3</sup></sup> to 75<sup>cm<sup>3</sup></sup>. Much trouble was experienced, however, at this dilution; for the last traces of the metal were driven from the solution only with extreme difficulty and with much loss of time, as may be noted by comparing the time interval of most of the experiments with the shorter interval of the last two experiments of the second series, where the dilution was 45 to 50<sup>cm<sup>3</sup></sup>. Moreover it was found advisable, in order to avoid mechanical loss, to deposit not more than 0.2 gram. to 0.25 gram. of the metal upon the cathode, while even smaller quantities are to be preferred. The current density must also be kept within the limits indicated; for otherwise a spongy deposit may result. Cadmium seems to be especially liable to the formation of these spongy, unweighable deposits, and the greatest difficulties experienced in this investigation have come from this behavior of the metal.

The best condition, therefore, may be briefly summarized as follows: Cadmium sulphate, equivalent to not more than 0.2<sup>cm<sup>3</sup></sup> to 0.25 gram. of the metal, is dissolved in 45<sup>cm<sup>3</sup></sup> to 50<sup>cm<sup>3</sup></sup> of water; ten to fifteen drops of dilute sulphuric acid are added; and the proper connections made and the solution subjected to electrolysis as described, fifteen minutes being sufficient time for the complete deposition of the metal upon the cathode. It

\* Loc. cit.

is not necessary to heat the liquid, as the passage of such large currents soon heats it sufficiently. When electrolysis is complete, the excess of sulphuric acid may be destroyed with a slight excess of ammonia water, the current broken, and the cathode removed, thoroughly rinsed with water and alcohol, and dried by waving over a free flame. If the deposit is not spongy the drying is a matter of only a few moments, and there is no danger of oxidizing the metallic deposit. If it is preferred, the current may be reduced by interposed resistance, the rotation stopped, and the liquid readily siphoned without danger of injuring the metallic coating.

## II. *In Solutions containing Acetates.*

The next method to be studied in its application to the rotating cathode was the use of solutions containing acetates, as recommended by Edgar F. Smith. Originally, Smith used a solution obtained by dissolving cadmium oxide in acetic acid\* but later found that the electrolysis proceeded equally well in solutions containing the nitrate, chloride or sulphate of cadmium with an excess of sodium acetate.† In the study of the application of this method to the estimation of cadmium, taken as the sulphate, upon the rotating cathode, two methods of proceeding were followed, both of which had been previously used by Exner‡ in his work upon the rotating anode. In series A, of the experiments following, measured amounts of cadmium sulphate solution were run off from a burette, the indicated amount of sodium acetate was added in solution, a small amount of potassium sulphate was added to increase the conductivity of the solution, the whole diluted to the desired volume and electrolysis conducted as with the solution containing sulphuric acid. In series B, the cadmium in the measured solution was precipitated as the hydroxide with a sodium hydrate solution, the precipitate dissolved in a very slight excess of acetic acid, potassium sulphate added as before, and the solution subjected to electrolysis.

### SERIES A.

No.	Cd. taken. grm.	NaOC <sub>2</sub> H <sub>3</sub> O. grm.	K <sub>2</sub> SO <sub>4</sub> . grm.	Cur't read. = amp.	N.D <sub>100</sub> . amp	E.M.F. vts.	Time. min.	Cd. fd. grm.	Error. grm.
1.	0·1864	1·5	0·5	2·0	6·0	8·0	-	(§)	----
2.	0·1491	2·0	1·0	1·5	4·5	8·0	15	(  )	----
3.	0·1118	0·5	1·0	1·0	3·0	8·0	20	0·1121	+0·0003
4.	0·1491	1·5	0·5	0·9	2·7	8·0	15	0·1494	+0·0003
5.	0·1491	1·5	0·5	0·9	2·7	8·0	15	0·1496	+0·0005
6.	0·1223	1·5	0·5	0·75	2·25	7·5	20	0·1237	+0·0014

\* Ber., xi, 2048 (1878).

† Am. Ch. J., ii, 41 (1880).

‡ J. Am. Ch. Soc., xxv, 896 (1903).

§ Did not weigh, as precipitate was non-adherent. Current too high for quantity of cadmium present.

|| Deposits spongy and blistered. Too much electrolyte present.

SERIES B.

No.	Cd. taken. gram.	NaOH. gram.	K <sub>2</sub> SO <sub>4</sub> . gram.	Cur't = amp.	N.D <sub>100</sub> amp.	E.M.F. vts.	Time. min.	Cd. found. gram.	Error. gram.
1.	0·1491	excess	0·5	1·25	3·75	8·0	10	0·1496	+ 0·0005
2.	0·1491	0·2	0·5	0·8	2·4	8·0	15	0·1491	± 0·0000
3.	0·1491	0·2	0·5	0·8	2·4	8·0	15	0·1493	+ 0·0002
4.	0·1223	0·5	0·2	1·0	3·0	12·0	20	0·1223	± 0·0000
5.	0·1223	0·5	0·2	1·0	3·0	12·0	20	0·1223	± 0·0000
6.	0·1223	0·2	0·5	1·25	3·75	7·5	10	0·1227	+ 0·0004

In both series the volume of the solution was about 60<sup>cm</sup><sup>3</sup> to 65<sup>cm</sup><sup>3</sup>. The sixth experiment in each series will indicate the result when the greater concentration of 45<sup>cm</sup><sup>3</sup> to 50<sup>cm</sup><sup>3</sup> was tried. In these cases the precipitate showed a tendency to sponginess, which was more noticeable in series A. At the greater dilution, the deposition of the cadmium proceeds rapidly and satisfactorily; the deposit is rather crystalline, fairly compact, and easily washed, so that the method forms one of the very best where the cadmium is taken in the form of the sulphate: the chloride and nitrate behave differently and will be treated later. The second modification seemed to give deposits more satisfactory than the first. Certain cautions, however, are to be observed. Not more than 0·1500 gram. may safely be estimated; the normal current density should not exceed 3·0 amperes if a spongy deposit is to be avoided; and, for the same reason, a large excess of electrolytes is to be avoided.

III. *In Solutions containing Cyanides.*

The deposition of cadmium from a solution of the double cyanide has always been very satisfactory, and the results with the rotating cathode were in complete accordance with previous work on this method. The range of conditions of current and quantity of electrolyte is broad, the deposit is a beautiful silvery plate, so compact as to be rubbed off only with difficulty, which dries very quickly; and although the complete deposition of the metal is not so rapid as it is from solutions containing sulphates or acetates, it is sufficiently rapid. Care should be taken to avoid foaming of the solution, as this retards somewhat the deposition of the final traces of cadmium. Generally, a volume of 65<sup>cm</sup><sup>3</sup> to 70<sup>cm</sup><sup>3</sup> was found most satisfactory. The solution was run off into a beaker of convenient size, the cadmium precipitated with sodium hydroxide, and the precipitate redissolved in potassium cyanide. The following results were obtained:

No.	Cd. taken. grm.	NaOH. grm.	KCN. grm.	Cur't read = amp.	N.D. <sub>100</sub> . amp.	E.M.F. vts.	Time. min.	Cd. found. grm.	Error. grm.
1.	0·1491	1·5	0·5	2·5	7·5	8	35	0·1498	+0·0007
2.	0·1491	1·0	0·5	2·5-4·5	7·5-13·5	8	30	0·1490	-0·0001
3.	0·1223	1·5	1·0	2·5	7·5	8	35	0·1225	+0·0002

IV. *In Solutions containing Pyrophosphates.*

Brand\* has recommended the use of a solution containing sodium pyrophosphate for the electrolytic estimation of metals, among others, cadmium: and the fitness of this solution for use with the rotating cathode was now studied. In each case the cadmium was precipitated with the indicated amount of sodium pyrophosphate, the precipitate dissolved in an excess of ammonium hydroxide (series A), phosphoric acid of 1·7 specific gravity (series B), sulphuric acid (series C), or hydrochloric acid (series D), and subjected to the action of the current. The volume of the solution was 60<sup>cm</sup>³.

While fairly accurate results may be obtained, the method is neither so accurate as those previously described, nor are the conditions so flexible. Particular care must be used to avoid too large a current, as a spongy deposit may result. The following were the results obtained:

SERIES A.									
No.	Cd. taken. grm.	Na <sub>4</sub> P <sub>2</sub> O <sub>7</sub> . grm.	NH <sub>4</sub> OH.	Cur't = amp.	N.D. <sub>100</sub> . amp.	E.M.F. vts.	Time. min.	Cd. fd. grm.	Error. grm.
1.	0·1491	0·5	15 <sup>cm</sup> ³ (1:4)	1·0-1·5	3·0-4·5	8	15	0·1498	+0·0007
2.	0·1491	0·5	excess.	0·4	1·2	8	15	0·1489	-0·0002
3.	0·1864	0·5	15 <sup>cm</sup> ³ (conc.)	0·7	2·1	8	15	0·1869	+0·0005
SERIES B.									
			H <sub>3</sub> PO <sub>4</sub> (1·7 sp. gr.)						
4.	0·1491	1·0	1·0 <sup>cm</sup> ³.	1·0	3·0	8	30	0·1496	+0·0005
5.	0·1864	1·0	1·0 "	1·0-1·5	3·0-4·5	8	30	0·1857	-0·0006
6.	0·1491	1·0	1·0 "	1·0	3·0	8	30	0·1493	+0·0002
SERIES C.									
			H <sub>2</sub> SO <sub>4</sub> .						
7.	0·1491	1·0	2 <sup>cm</sup> ³ (1:4)	2·0-2·5	2·0-7·5	8	30	0·1501	+0·0010
8.	0·1864	0·5	excess.	1·0-2·0	3·0-6·0	8	35	0·1862	-0·0002
SERIES D.									
			HCl.						
9.	0·1491	0·5	slt. excess.	1·0	3·0	8	37	0·1499	+0·0008
10.	0·1491	0·5	" "	1·0	3·0	8	36	0·1486	-0·0005

\* Z. anal. Ch. xxviii, 581 (1889).

In Nos. 1 and 3 a small amount of dilute sulphuric acid was added to increase the conductivity of the solution, but the time was not reduced thereby, while the resulting deposit was slightly spongy.

In No. 5 the cadmium was not quite all precipitated.

In No. 7 the precipitate was spongy.

#### V. *In Solutions containing Phosphates.*

The use of a solution containing the orthophosphates dissolved in phosphoric acid has been recommended by Smith\*, and this solution was next tried. The following results will show the scope of the modifications tried:

No.	Cd. taken. gm.	HNA <sub>2</sub> PO <sub>4</sub> . gm.	H <sub>2</sub> PO <sub>4</sub> (1:7) cm.	Total vol. cm.	Cur't. = amp.	N.D. <sub>100</sub> . amp.	E.M.F. vts.	Time. min.	Cd. fd. gm.	Error. gm.
1.	0·1491	0·5	1·0	75	1·0-1·2	3·0- 3·6	8	20	0·1477	-0·0014
2.	0·1491	0·5	5·0	75	2·0-2·5	6·0- 7·5	8	23	0·1496	+0·0005
3.	0·1491	0·5	5·0	75	2·0-1·5	6·0- 4·5	8	30	0·1508	+0·0017
4.	0·1491	0·5	3·0	75	2·5	7·5	12	25	0·1502	+0·0011
5.	0·1491	0·5	4·0	75	2·5	7·5	8	25	0·1485	-0·0006
6.	0·1491	9·5	2·0	75	2·5	7·5	12	35	0·1501	+0·0010
7.	0·1864	0·25	2·0	75	2·0-3·0	6·0- 9·0	12	40	0·1861	-0·0003
8.	0·1491	0·3	1·5	75	3·5	10·5	12	30	0·1502	+0·0011
9.	0·1019	0·25	5·0	75	2·5-3·0	7·5-9·0	7·8	30	0·1024	+0·0005
10.	0·1019	0·25	5·0	75	3·0-3·5	9·0-10·5	7·8	30	0·1027	+0·0008
11.	0·1223	0·2	5·0	75	3·0-3·5	9·0-10·5	7·8	40	0·1221	-0·0002

No. 1.—Not all out. No. 2.—Slight yellow color with H<sub>2</sub>S. No. 3.—Slight yellow with H<sub>2</sub>S. No. 4.—Spongy. No. 5.—Not all out. No. 6.—Spongy. No. 10.—Spongy. No. 11.—Slight test with H<sub>2</sub>S.

From this series of experiments it may be seen that the method may be made to give fair results if the following conditions are closely adhered to: for a total volume of 75<sup>cm</sup><sub>3</sub>, the cadmium is precipitated with 0·25 gm. of hydrogen disodic phosphate, 5<sup>cm</sup><sub>3</sub> of phosphoric acid (sp. gr. = 1·7) added, and the solution electrolyzed with a current of about 8 volts potential. If the normal current density does not exceed 9 amperes, the deposit will be fair, and complete in about 30 minutes.

#### VI. *In Solutions containing Oxalates.*

Much work was expended upon the oxalate method, but in spite of this, a satisfactory deposit could not be obtained. When ammonium oxalate was present, even in small amounts, the deposit was very spongy: while the use of sodium oxalate alone, when carried down even to the smallest excess possible

\*Am. Ch. J., xii, 329 (1890).

to give a soluble double oxalate, gave results much too high. The dissolving of the precipitated oxalates in various reagents furnished no solution to the problem.

The results in the following table will show the scope of the work done :

No.	Cd. tkn. grm.	Am. oxalate. grm.	Pot. oxalate. grm.	Solvent.	Cur't = amp.	N. D. <sub>100</sub> amp.	E.M.F. vts.	Time. min.	Cd. fd. grm.	Error. grm.
1.	0·1491	excess	none	none	3·0	9·0	12	?	0·1558	+ 0·0067
2.	0·1491	slt. excess	none	"	2·5	7·5	12	30	0·1506	+ 0·0015
3.	0·1491	2·0	0·5	"	2·0 - 2·5	6·0 - 7·5	8	25	0·1531	+ 0·0040
4.	0·1491	none	0·5	{ H <sub>2</sub> SO <sub>4</sub> 15 dps.	2·5	7·5	8	30	0·1476	- 0·0015
5.	0·1491	"	8·0	none	2·0	6·0	6·2	20	0·1507	+ 0·0016
6.	0·1118	4·0	none	"	1·5	4·5	6·1	20	0·1272	+ 0·0154
7.	?	none	5·0	{ NH <sub>4</sub> OH <sub>3</sub> few cm.	2·0 - 3·5	6·0 - 10·5	6-8	18	?	?
8.	0·1118	"	5·0	none	1·5	4·5	6·0	15	0·1129	+ 0·0011
9.	0·1019	"	4·0	"	2·0 - 3·0	6·0 - 9·0	8	20	0·0995	- 0·0024
10.	0·1019	"	6·0	"	0·5 - 1·5	1·5 - 4·5	4-6	35	0·0982	- 0·0037
11.	0·1019	"	5·0	"	1·0	3·0	5·5	55	0·1033	+ 0·0014
12.	0·1019	"	7·0	"	0·5	1·5	4	55	0·1030	+ 0·0011
13.	0·1223	2·0	8·0	"	0·1 - 0·15	0·3 - 0·45	4	60	0·1236	+ 0·0013
14.	0·1223	2·0	8·0	"	0·02-0·10	0·06- 0·3	4	76	0·1229	+ 0·0006
15.	0·1223	{ KOH 1 grm.	{ H <sub>2</sub> SO <sub>4</sub> dil. 10 <sup>cm</sup>	{ oxalic acid 5 grm.	3·0	9·0	8	40	0·0876	- 0·0347
16.	0·1223	{ KOH 0·25 grm.	----	{ oxalic acid 10 grm.	----	----	--	--	----	----
17.	0·1019	----	----	{ oxalic acid 1 grm.	1-2	3-6	8	35	0·1033	+ 0·0014
18.	0·1019	----	----	{ oxalic acid 3·5 grm.	3	9	8	60	0·1018	- 0·0001

Of these, numbers 1, 2, 3, 6, 8, 9, 14, 15, 17, and 18 gave very spongy precipitates, while No. 7 was so spongy that it could not be satisfactorily dried, and so was not weighed. In experiments numbered 4, 9, 10, 14, 15, and 18 the cadmium was not all precipitated in the time allowed. In No. 10, also the precipitate was non-adherent. In No. 16, the oxalate was precipitated and was not broken up by the current.

#### VII. *In Solutions containing Urea, etc.*

Balachowsky\* obtained good results by the electrolysis of solutions containing, in addition to cadmium salts, urea and various aldehydes. These solutions were found to offer no difficulties with the rotating cathode, when cadmium sulphate is taken, as may be seen from the following results. The deposits were gray, compact, and quickly dried. The solution was diluted to about 60<sup>cm<sup>3</sup></sup> or 70<sup>cm<sup>3</sup></sup>, and the best current potential was found to be that given by six storage cells connected in series—approximately 11·8 volts.

\* Compt. rend., cxxxi, 385 (1900).

SERIES A.—Urea, 3 grms.

No.	Cd. taken. gm.	Cur't = amp.	N.D <sub>100</sub> . amp.	Time. min.	Cd. found. gm.	Error. gm.
1.	0·1019	0·25-0·5	0·75-1·5	35	0·1018	-0·0001
2.	0·1223	0·2	0·6	35	0·1223	±0·0000
3.	0·1223	0·25-0·5	0·75-1·5	30	0·1230	+0·0007

SERIES B.—Formalin, 2<sup>cm</sup>³.

1.	0·1019	0·1 -1·0	0·3 -3·0	30	0·1018	-0·0001
2.	0·1223	0·2 -1·0	0·6 -3·0	30	0·1224	+0·0001
3.	0·1223	0·2 -1·0	0·6 -3·0	30	0·1225	+0·0002

SERIES C.—Acetaldehyde, 2<sup>cm</sup>³.

1.	0·1019	0·1 -0·8	0·3 -2·4	35	0·1022	+0·0003
2.	0·1223	0·1 -0·8	0·3 -2·4	30	0·1228	+0·0005
3.	0·1223	0·1 -0·8	0·3 -2·4	30	0·1222	-0·0001

Since the conductivity of the solutions containing urea and the aldehydes is comparatively low, the effect of adding electrolytes was tried. The rate of deposition was very much increased, but the precipitated metal showed such tendency toward sponginess that this procedure is not to be highly recommended. The following were the tests tried :

SERIES A.—Urea, 3 grms.; Time, 20 min.; E.M.F., 7·8 volts; Current read, 0·5 amperes; N.D<sub>100</sub>, 1·5 amperes.

No.	Cd. taken. gm.	Electrolyte.	Cd. found. gm.	Error. gm.	Notes.
1.	0·1019	K <sub>2</sub> SO <sub>4</sub> , 0·5 gm.	0·1031	+0·0022	spongy.
2.	0·1019	same	0·1031	+0·0022	"
3.	0·1019	{ H <sub>2</sub> SO <sub>4</sub> (1:4) 5 drps.	0·1023	+0·0004	good ppt.
4.	0·1019	same as 3	0·1027	+0·0008	slt. spgy
5.	0·1019	{ H <sub>2</sub> SO <sub>4</sub> (1:4) 8 drps.	0·1027	+0·0008	" "

SERIES B.—Formaldehyde (formalin), 2·5<sup>cm</sup>³; Time, 20 min.; E.M.F. 7·9 volts. Current started at 0·5 ampere and rose to 1·0 ampere at the end of the process (N.D<sub>100</sub> = 1·5-3·0 amperes.) In each case the precipitate was good. Ten drops of dilute sulphuric acid were added to increase the conductivity of the solution.

No.	Cd. taken. gm.	Cd. found. gm.	Error. gm.
1.	0·1019	0·1020	+0·0001
2.	0·1019	0·1019	±0·0000

VIII. *In Solutions containing Formates.*

The use of the solutions containing potassium formate and a slight excess of formic acid has been recommended,\* but I

\* Warwick, Z. anorg. Ch., i, 285 (1892); Avery and Dales, J. Am. Ch. Soc., xix, 380 (1897).

was unable to adapt this method to the rotating cathode. When potassium formate was present in even the smallest amounts the precipitate was spongy, and non-adherent. From solutions containing formic acid alone, however, the metal is deposited in a satisfactory form, but only after long passage of the current. The following results will show the limit of applicability of the process, experiments numbered 8 and 9 seeming to represent the most desirable conditions:

No.	Cd. tkn. grm.	KCHO <sub>2</sub> sat. sol. cm <sup>3</sup> .	HOCHO.	Cur't = amp.	N.D. <sub>100</sub> . amp.	E.M.F. vts.	Time. min.	Cd. fd. grm.	Error. grm.
1.	0·1019	2	--	1·0 -2·0	3-6	8	17	} Not weighed ; ppt. blistered and dropped off.	
2.	0·1223	0·5	--	0·4	1·2	8	--		
3.	0·1223	0·5	--	0·4	1·2	8	--		
4.	0·1223	0·5	--	0·4	1·2	8	--		
5.	0·1223	--	15 dps.	0·25-0·8	0·75-2·4	12	25	0·1228	+0·0005
6.	0·1223	--	15 "	0·25-0·8	0·75-2·4	8	25	0·1212	-0·0010
7.	0·1223	--	21 "	0·5 -1·5	1·5 -4·5	12-16	35	0·1202	-0·0021
8.	0·1019	--	1·5cm <sup>3</sup>	0·5 -1·0	1·5 -3·0	12	60	0·1022	+0·0003
9.	0·1223	--	1·5 "	0·4 -1·0	1·2 -3·0	12	55	0·1218	-0·0005

In the experiments numbered 5, 6 and 7 the cadmium was not all precipitated in the time indicated, as was shown by testing the solution with hydrogen sulphide.

#### IX. *In Solutions containing Tartrates.*

Solutions containing ammonium tartrate were also tried, but failed to give satisfactory deposits, the deposit in each case being spongy. If the solution contain only tartaric acid, however, in place of its salts, fairly satisfactory results may be obtained, as shown by the following table:

No.	Cd. tkn. grm.	Tartaric acid. grm.	Cur't = amp.	N.D. <sub>100</sub> . amp.	E.M.F. vts.	Time. min.	Cd. fd. grm.	Error. grm.
1.	0·1223	3	0·5-1·0	1·5-3·0	8	20	0·1212	-0·0011
2.	0·1223	2	0·5	1·5	8	30	0·1216	-0·0007
3.	0·1223	2	0·5	1·5	8	50	0·1215	-0·0008
4.	0·1019	3	1·5	4·5	11·8	18	0·1022	+0·0003

Tests with hydrogen sulphide showed that the cadmium was not all precipitated in the tests numbered 1, 2 and 3, which were performed at a dilution of 70<sup>cm<sup>3</sup></sup>; experiment 4 was performed at a dilution of 50<sup>cm<sup>3</sup></sup>. It will be noted that, as in the sulphate process, the last traces of cadmium are thrown out of the higher state of dilution only with extreme difficulty.



ART. XXX.—*The Crystallization of Luzonite; and other Crystallographic Studies*; by ALFRED J. MOSES.1. *The Crystallization of Luzonite.*

THE reddish bronze, fine-grained variety of  $\text{Cu}_3\text{AsS}_4$  which is found in the copper veins of Mancayan, Luzon Island in the Phillipines, has been generally accepted as dimorphous with enargite, but the minute crystals, "tiny individuals of unrecognizable form,"\* observed in the cavities growing from the granular mass have not been measured but rather referred to as "indistinct, uneven, striated crystals not rhombic but monoclinic or even triclinic."†

Recently Mr. Maurice Goodman, senior field assistant in the Bureau of Mines, Manila, collected a number of luzonite specimens showing these crystals in cavities, from which I selected and measured the crystals here described.

*Crystals No. 1 and No. 2.*—A mass of typical luzonite, free from all visible columnar blackish enargite, showed a number of cavities the walls of which were crystallized; that is, little detached fragments of the walls under the microscope were seen to be faceted by minute crystals which projected very slightly and the faces of which could be traced down until they merged in the bronze-colored mass. They were not implanted on or enclosed in the mass, but distinctly suggested that the mass on solidifying formed little facets such as form on the cooling of a fused mass of pyromorphite. It is curious and probably of genetic significance, that the terminal planes of these crystals are decidedly lighter in color and of less brilliant luster than the side planes, the latter suggesting the dark gray of enargite or stibnite and the former a reddish steel-gray not very different from the tint of the massive luzonite. In more than one instance in which a fracture extended across a crystal into the massive material it was impossible to see any difference in the color or character of the surfaces.

Two little crystals were mounted for measurement. No. 1, shown in fig. 1, was only  $\frac{1}{8}$  to  $\frac{1}{2}$  mm in any direction, but was attached to a fragment of the mass from which it had developed. Signals were obtained in the two-circle goniometer from seven faces but were a little blurred. Crystal No. 2, shown in fig. 2, was the largest crystal I observed as a cavity wall facet, and its terminal face was approximately a rhomb of  $1\frac{1}{2} \times \frac{2}{3}$  mm. It also yielded signals from seven faces and a series of signals from a curved triangular surface.

In both crystals the terminal faces were reddish steel-gray and the vertical faces dark gray. Taking the terminal faces

\* Weisbach, *Tscher. Min. Mitth.*, 1874, 257.

† Frenzel, *ibid.*, 1877, 303.

as  $c = 001$ , the consideration of the angles in the vertical zone suggested an orientation for comparison with the common forms of enargite as follows :

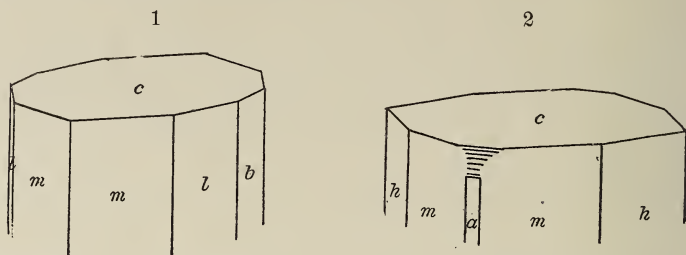

Enargite Form.	Face.	Crystal No. 1.		Face.	Crystal No. 2.	
		Signal.	Measured $\phi$ .		Signal.	Measured $\phi$ .
$c = 001$	1	Fair	----	1	Fair	----
$m = 110$	5	Double	$48^\circ 57'$	2	Double	$49^\circ 02'$
	6	"	$48^\circ 58'$	5	Fair	$48^\circ 44'$
	7	Blurred	$48^\circ 30'$	-	----	----
$h = 120$	-	----	----	3	Faint	$31^\circ 44'$
$l = 130$	2	Fair	$20^\circ 22'$	-	----	----
	4	Double	$19^\circ 17'$	-	----	----
$b = 010$	3	"	$0^\circ 5'$	-	----	----
$a = 100$	-	----	----	7	Double	$89^\circ 46'$
$h0l$	-	----	----	curved	Series	$90^\circ 0'$

The comparison of the averaged angles is :

Enargite $\phi$ .	Crystal No. 1 $\phi$ .	Crystal No. 2 $\phi$ .
$m = 48^\circ 59' 47''$	$48^\circ 48'$	$48^\circ 56'$
$h = 29^\circ 54' 13''$	----	$31^\circ 44'$
$l = 20^\circ 58' 38''$	$20^\circ 22'$	----
$b = 0^\circ$	$0^\circ 5'$	----
$a = 90^\circ$	----	$89^\circ 46'$

That is, *all* the angles are those of the common forms of enargite within the limits of accuracy that the measurement of minute crystals with rather dull  $c$  faces and somewhat striated vertical faces would permit.

*Crystals No. 3 and No. 4.*—The relatively simple crystals from the cavity walls connect directly with the two other more highly modified crystals here described.

Upon another specimen and so in contact with the massive luzonite as to be, in my opinion, developed from it, were a number of little, bright, highly modified crystals which like Nos. 1 and 2 are much lighter colored on the terminal faces than on the side or prism faces. Crystal No. 3 was the best of these found, and as shown in fig. 3 it proved to include all the forms of Nos. 1 and 2 as well as those of the later described crystal 4. Its size was  $\frac{1}{2} \times \frac{1}{3} \times 1^{\text{mm}}$  in the directions  $\check{a}$ ,  $\check{b}$ ,  $\check{c}$  respectively.

From still another specimen of massive luzonite, but resting upon it rather than growing from it, was a little group of black lustrous crystals, the best of which, crystal No. 4, shown in fig. 4, measured  $\frac{3}{10} \times \frac{1}{2} \times \frac{5}{4}$  mm in the directions  $\bar{a}$ ,  $\bar{b}$ ,  $\bar{c}$ , which,

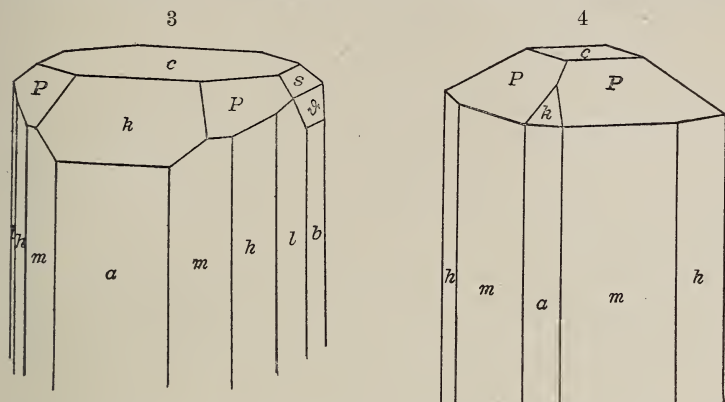

while differing from all described enargite crystals in the presence of a pyramid,  $P=223$ , as its most prominent terminal form, connects directly with crystal No. 3 by the fact that this pyramid and all the other forms of the crystal are prominent on crystal 3.

Both crystals were measured in the two-circle goniometer. Crystal No. 3 yielded good to fine signals from twenty-one faces and poorer ones from four others, while crystal No. 4 yielded good signals from twelve faces and poorer from two others. The average results tabulate as follows:

Form.	Crystal.	Number faces.	Measured angles.		Computed enargite angles.	
			$\phi$	$\rho$	$\phi$	$\rho$
$c$ (001)	3	1	----	$0^\circ$	----	$0^\circ$
"	4	1	----	$0^\circ$	----	----
$b$ (010)	3	1*	$0^\circ$	$89^\circ 49\frac{1}{2}'$	$0^\circ$	$90^\circ$
$a$ (100)	3	2	$90^\circ 04\frac{1}{2}'$	$90^\circ$	$90^\circ$	$90^\circ$
"	4	2*	Approx. $90^\circ$	$90^\circ$	----	----
$m$ (110)	3	4	$49^\circ 02'$	$90^\circ$	$48^\circ 59' 47''$	$90^\circ$
"	4	4	$48^\circ 57'$	$90^\circ$	----	----
$h$ (120)	3	4	$29^\circ 56\frac{1}{2}'$	$90^\circ$	$29^\circ 54' 13''$	$90^\circ$
"	4	1	$30^\circ 03'$	$90^\circ$	----	----
$l$ (130)	3	1	$20^\circ 50'$	$90^\circ$	$20^\circ 58' 38''$	$90^\circ$
$s$ (011)	3	1*	$0^\circ 1'$	$39^\circ 40'$	$0^\circ$	$39^\circ 36' 16''$
$\bar{s}$ (051)	3	2*	$0^\circ$	$76^\circ 18'$	$0^\circ$	$76^\circ 24' 40''$
$\bar{h}$ (101)	3	2	$90^\circ 5'$	$43^\circ 39'$	$90^\circ$	$43^\circ 34' 56''$
"	4	2	$90^\circ$	$43^\circ 40\frac{1}{2}'$	----	----
P (223)	3	4	$49^\circ 1\frac{1}{2}'$	$39^\circ 54'$	$48^\circ 59' 47''$	$40^\circ 3' 16''$
	4	4	$48^\circ 59'$	$39^\circ 56'$	----	----

\* Poor signals.

*The Calculated Angles of Enargite.*—The axial elements calculated by Dauber\* in 1854 are

$$\check{a} : \bar{b} : \check{c} = 0.8711 : 1 : 0.8248$$

based upon angles of  $mm = 82^\circ 7'$  and  $cs = 39^\circ 31'$ .

In 1895 Fletcher† calculated new elements

$$\check{a} : \bar{b} : \check{c} = 0.8694 : 1 : 0.8308$$

based upon angles  $mm = 82^\circ 0\frac{1}{2}'$  and  $ck = 43^\circ 42'$

This value of  $mm$  is the average of so many measurements that it cannot well be questioned and it is not far from the angles here obtained since the mean of twenty  $\phi$  angles of 110 and 223 is  $48^\circ 57\frac{1}{2}'$  and Fletcher's  $mm = 82^\circ 0\frac{1}{2}'$  yields  $\phi$  of  $110 = 48^\circ 59\frac{3}{4}'$ .

Fletcher's value for  $\check{c}$ , however, considers only the faces  $k = 101$  and is the mean of some fourteen values of  $ck$ . The new pyramid,  $P = 223$ , is represented on crystals Nos. 3 and 4 by eight good faces and the readings especially in crystal 4 are close. The angles  $\phi$  and  $\rho$  of 223 in crystal 4 yield  $\check{a} : \bar{b} : \check{c} = .8698 : 1 : .8241$ , essentially those of Fletcher in the case of  $\check{a}$  but not so near in the case of  $\check{c}$ .

I have therefore used in my calculation an intermediate value for  $\check{c}$  of .8274, which is also an approximate mean between the  $\check{c}$  values of Fletcher and Dauber.

In conclusion, these results show that the crystals which form at the solidification of luzonite and those which form possibly later on luzonite have the angles of enargite. In other words, "luzonite" is not an independent species but merely a variety of enargite.

I base this claim principally on the angles here recorded for the small and relatively simple crystals Nos. 1 and 2, which are types of the cavity-wall crystals so connected with the massive material that it is impossible to doubt that they are the results of its solidification.

Crystal No. 3 I believe to have formed in the same manner but under more favorable conditions, while crystal No. 4 is evidently secondary. The new form  $P = 223$ , prominent in both, connects them however.

The observed color difference on the terminal faces and vertical faces of the cavity-wall crystals, and crystal No. 3, probably has genetic significance. The recorded analysis by Winkler is of practically pure material, which makes inadmissible a theory of crystallographic regularity in elimination of impurities. The comparative dullness of the basal plane in Nos. 1 and 2 might suggest a light effect explaining the color,

\* Pogg. Ann., lxxiii, 383, 1854.

† Mineralogical Magazine, xi, 73, 1895.

but in crystal No. 3  $c$  is bright and the color is still reddish steel-gray. Tarnish does not seem to explain it, as enargite usually tarnishes a blue-black, and finally the possible deposition of a thin layer of dark-colored enargite observed on pyrite associated with Morococho enargite seems not to explain, since the cleavage on No. 3 is also of the dark gray color.

## 2. Crystallized Wolframite from Boulder Co., Col.

Mr. Morris K. Jones, of Boulder, Colorado, sent me a sack of tungsten ore from different lodes in the property of the Great Western Exploration and Reduction Co., situated about twelve miles west of the city of Boulder.

The mineral, which varies in the percentage of manganese in the different lodes, occurs in most of the specimens as the cementing material of a brecciated rock composed chiefly of fine-grained quartz and partially decomposed feldspar. The spaces between the angular rock fragments are filled with the

5

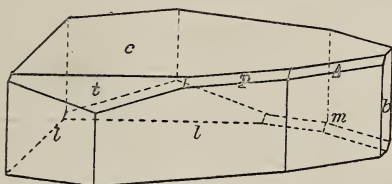

crystalline black ore, the crystals often crossing the crevices. Occasionally the ore thickens to a considerable mass.

On breaking the specimens numerous black brilliant little crystals were found, rarely exceeding  $1\frac{1}{2}$  to  $2^{\text{mm}}$  in their longest dimension. So far as observed none of the crystals is doubly terminated in the direction of the  $\bar{b}$  axis, but all have grown out in that direction from the mass. This and the frequent existence at the visible end of a rectangular face or cleavage  $b = 010$  suggests at first examination a simple combination of the three pinacoids. The actual form, however, is that shown in figure 5.

Two crystals, each ending in a  $b$  cleavage and essentially alike in habit, were measured. Crystal No. 1 was  $\frac{2}{3} \times \frac{1}{3} \times \frac{2}{3}^{\text{mm}}$  in the directions  $\bar{a}$ ,  $\bar{b}$ ,  $\bar{c}$ , and crystal No. 2 a trifle larger.

The forms identified by the measurements were:

*Prismatic zone*— $l = 210$ ;  $m = 110$ ;  $b = 010$ ; all yielding good signals from bright decided faces of both crystals.

In addition a signal was obtained from both crystals which closely corresponded to  $\bar{d} = 310$ . It was, however, evidently a second element in the striations upon the faces  $l = 210$ .

The largest face in each crystal was undoubtedly  $c = 001$ , but these faces were so striated that the series of images gave values for  $\rho$  each side of the correct position through four or five degrees, and probably involved various indeterminable domes  $h\ 0\ l$  and  $\bar{h}\ 0\ l$ .

The remaining forms determined were  $t = 102$  well developed;  $\Delta = 112$  minute but bright, and a new form,  $p = 214$  occurring as a narrow truncation.

The comparison between the measured and computed coordinate angles for  $l$ ,  $m$ ,  $t$ ,  $\Delta$  and  $p$  is:

Face.	Measured.		Calculated.	
	$\theta$	$\rho$	$\theta$	$\rho$
$l$	$67^\circ 36\frac{3}{4}'$	$90^\circ$	$67^\circ 34\frac{1}{2}'$	$90^\circ$
$m$	$50^\circ 15'$	$90^\circ$	$50^\circ 27\frac{1}{2}'$	$90^\circ$
$t$	$89^\circ 52\frac{1}{2}'$	$28^\circ 10\frac{1}{2}'$	$90^\circ$	$28^\circ 3'$
$\Delta$	$51^\circ 58'$	$34^\circ 10\frac{1}{2}'$	$50^\circ 53\frac{1}{2}'$	$34^\circ 29'$
$p$	$68^\circ 45'$	$30^\circ 17'$	$68^\circ 6'$	$30^\circ 8\frac{1}{2}'$

Upon a few of the specimens there were small yellow sphalerite crystals and small crystals of scheelite not suitable for measurement.

### 3. New Faces on Sylvanite Crystal from Cripple Creek, Col.

Some three or four years ago Mr. F. C. Hamilton purchased some telluride specimens from a dealer at Cripple Creek, Col., and presented them to Columbia University. Among these was a mass of  $3\frac{1}{2}$  oz. in weight which consisted almost entirely of large crystals and crystal bunches some of them  $20 \times 5^{\text{mm}}$  in length and breadth. Nearly every one of these was partly coated with a thin layer of chalcedony, but many brilliant faces and cleavages were visible.

There were a few smaller crystals upon the mass which were nearly free from chalcedony; one of these was so symmetrical that it was measured under the impression that it was orthorhombic and possibly a highly modified krennerite. The angles, however, quickly proved its identity with sylvanite.

The dimensions of the crystal were approximately  $1 \times 1 \times 2^{\text{mm}}$  in the directions  $\bar{a}$ ,  $\bar{b}$ ,  $\bar{c}$ . For better adjustment the crystal was mounted in the two-circle goniometer with the large  $\bar{b} = (010)$  face parallel to the vertical circle, and centered by this face and the faces of the zone  $[100\ 001]$ . The results were then transformed.

Twenty-six forms were identified, of which twenty have been previously described by Dr. Chas. Palache\* on crystals from Cripple Creek; two others,  $\bar{M} = \bar{1}01$  and  $p = 112$ , are recorded forms not previously noticed on the crystals from this locality

\* This Journal, x, 419, 1900.

and four are new domes  $H=102$ ,  $T=103$ ,  $l=203$  and  $L=\bar{2}03$ . The following angles give the proofs for these previously unrecorded and new forms:

	Measured $\rho$ .	Calculated $\rho$ .
$M=\bar{1}01$ .....	$34^{\circ} 35\frac{1}{2}'$	$34^{\circ} 18'$
$H=102$ .....	$19^{\circ} 19'$	$19^{\circ} 12\frac{1}{2}'$
$l=203$ .....	$24^{\circ} 50\frac{1}{2}'$	$24^{\circ} 55'$
$T=103$ .....	$13^{\circ} 16\frac{1}{2}'$	$13^{\circ} 4\frac{1}{2}'$
$L=\bar{2}03$ .....	$24^{\circ} 13'$	$24^{\circ} 27'$

For the pyramid  $p=112$

Measured angles.....	$\phi=31^{\circ} 18'$	$\rho=33^{\circ} 30'$
Calculated angles.....	$\phi=32^{\circ} 0\frac{1}{2}'$	$\rho=33^{\circ} 35\frac{1}{2}'$

The occurring forms and their relative development may be judged by the following tabulation. The forms in the first column are in most cases composed of fine relatively large faces; the largest, however, being the three pinacoids and the three domes 102,  $\bar{1}01$ ,  $\bar{2}03$ . All of these domes are new to the locality.

Type.	Faces yielding fine signals.	Faces yielding good signals.	Faces yielding faint signals.
Pinacoids..	001, 010, 110	----	----
$hk0$ .....	110, 210	310	----
$okl$ .....	----	011	----
$h0l$ .....	102, 101	203	103
$\bar{h}0l$ .....	$\bar{1}01$ , $\bar{2}03$	----	----
$hkl$ .....	121, 321	111, 112, 123	141, 323, 521
$\bar{h}kl$ .....	$\bar{1}21$ , $\bar{3}21$	$\bar{1}11$ , $\bar{1}23$	$\bar{5}21$

#### 4. Hematite Parting from Franklin Furnace, N. J.

A mass of ore from Franklin Furnace, N. J., weighing about two pounds, consisted principally of hematite with a very marked rhombohedral parting. With the hematite was calcite also showing a parting (parallel to  $01\bar{1}2$ ) and enclosed within the calcite was a broken crystal about one inch in diameter which consisted of a well-defined crust of hematite with the parting, the red streak, the very feeble manganese and very weak magnetism; and a core of franklinite with different luster, no parting, brown streak, decided manganese reaction and decided magnetism.

For record the nearly cubical parting was measured. The signals are not bright and there is a little calcite between the parting surfaces. Two angles of a fragment yielded respectively  $94^{\circ} 35'$ ,  $93^{\circ} 52'$  or an average of  $94^{\circ} 13'$ . The unit rhombohedron angle of hematite is  $94^{\circ} 0'$ .

Mr. John Crawford, Jr., made triplicate analyses for me of selected material for total iron and for FeO, the result being:

Fe per cent.	FeO per cent.
67·15	1·97
67·07	1·66
67·22	1·54
<hr/>	<hr/>
67·15 average.	1·72 average.

Deducting the 1·34 Fe equivalent to 1·72 FeO leaves 65·81 Fe present as Fe<sub>2</sub>O<sub>3</sub> or 94·00 per cent.

The total analysis becomes :

Insoluble .....	1·50
CaO calculated to CaCO <sub>3</sub> .....	2·85
Fe <sub>2</sub> O <sub>3</sub> .....	94·00
FeO .....	1·72
	<hr/>
	100·07

Or recalculating the Fe<sub>2</sub>O<sub>3</sub> and FeO to 100 per cent.

Fe <sub>2</sub> O <sub>3</sub> .....	98·20 per cent.
FeO .....	1·80 "

Columbia University, June, 1905.



ART. XXXI.—*The Determination of the Optical Character of Birefracting Minerals*; by FRED. EUGENE WRIGHT.

MINERALS are recognized in the thin section chiefly by their crystallographic properties and by the effect they have on transmitted light. The more important optic features used in their microscopic discrimination are color, pleochroism, refractive index, birefringence, optical orientation, angle between the optic axes ( $2V$ ),\* and optical character. Of these the latter two are determined in convergent polarized light and are well adapted for general application. They furnish exclusive data as to the nature of a given mineral, and can be accomplished by ordinary petrographic microscopes.

The optical character of a mineral, whether positive or negative, depends by definition solely on the value of the bisector of the acute angle between the optic axes; it is, therefore, independent of the crystal system and pertains to all birefracting minerals. The usual methods available for its determination, however, apply in practice only to uniaxial minerals and to those biaxial minerals for which the angle between the optic axes in air ( $2E$ ) is less than  $80^\circ$ ; if  $2E$  exceeds this limit, the traces of the optic axes lie outside of the microscopic field and give rise to uncertainty as to the position of the acute bisectrix, thereby seriously affecting the results. There are several methods, however, which, although not novel in principle, are scarcely recognized in literature, and which practically obviate this difficulty. They are based on phenomena observed in convergent polarized light with nicols crossed and apply equally well to uniaxial and biaxial minerals.

A general consideration of microscopic mineral determination shows conclusively that the optical character of minerals is one of their most useful traits for practical determination since the means employed are simple and of easy application. The following paragraphs aim to present these methods from a working standpoint, the necessary theoretical data appearing in fine print.

The crystal sections of birefracting minerals, from which decisive interference figures can be obtained, are those cut exactly or nearly perpendicular to the bisectrices of the optic axes, to the optic axes, and parallel to the plane of the optic axes. These sections and the methods applicable to them can be discussed for all birefracting substances if uniaxial minerals are treated as a limiting case of biaxial minerals.

\* The use of the term optic binormal in place of "optic axes" as proposed by Mr. L. Fletcher in his treatise on *The Optical Indicatrix* may be an improvement on the original term, but since the distinction implied by the words uniaxial and biaxial is in use in all languages, is convenient and causes no confusion, it is probable that the original designation will remain.

The figures 1-6, used to illustrate the methods, were obtained in part by graphical and in part by mathematical means based on the law of Fresnel, that the planes of polarization for rays traveling in any direction bisect the angles between the planes containing the ray and the two optic axes respectively; in other words, the directions of extinction for any face bisect the angles between the projections of the optic axes on the face.

*Plates cut perpendicular to the acute bisectrix.*

For birefracting minerals in which  $2E$  is less than  $80^\circ$ , the methods ordinarily described in text-books are applicable and satisfactory. Both optic axes appear then in the field, and the optical character can be ascertained in convergent polarized light by observing the change in position of the lemniscatic interference curves in alternate quadrants on the insertion of a quartz wedge or a plate showing the interference-color red of the first order, or a quarter-undulation mica plate. The numerical value of  $2E$  can also be measured on the same section by the Bertrand-Mallard\* method described below. For minerals whose  $2E$  is greater than  $80^\circ$ , a method described by Michel Lévy† for determining whether the section is perpendicular to the obtuse or the acute bisectrix can be used to advantage. It consists in observing the angle of revolution of the stage from the position where the black achromatic curves of the interference figure form a cross to that at which they are tangent to a given circle (usually field of the microscope). From this angle  $2E$  can be determined, and from it in turn the true optic axial angle ( $2V$ ), if the medium index of refraction of the substance be known.

It can be proved both mathematically and graphically that the dark achromatic hyperbolas, which form during the revolution of the stage, pass through the traces of the optic axes and recede from the field along the diagonals of the principal planes of the nicols. Practically, the course of procedure is to find a plate cut perpendicular to the bisectrix, to record the angle of revolution of the stage from the point where the dark hyperbolas intersect to that at which they are tangent to a given circle within the field of vision. From this angle the corresponding axial angle in air can be obtained by using fig. 1a, provided the Mallard constant of the microscope has been previously determined. If the medium refractive index of the mineral is also given, it is possible to convert  $2E$  into  $2V$  by means of fig. 1b.

\* E. Bertrand in Mallard, *Miner. physique*, 11, 418. E. Mallard, *Sur la mesure de l'angle des axes optiques*. *Bull. Soc. miner.*, 1882, page 77 et seq.

† Michel Lévy, *Minéraux des Roches*, 94-95.

FIG. 1.

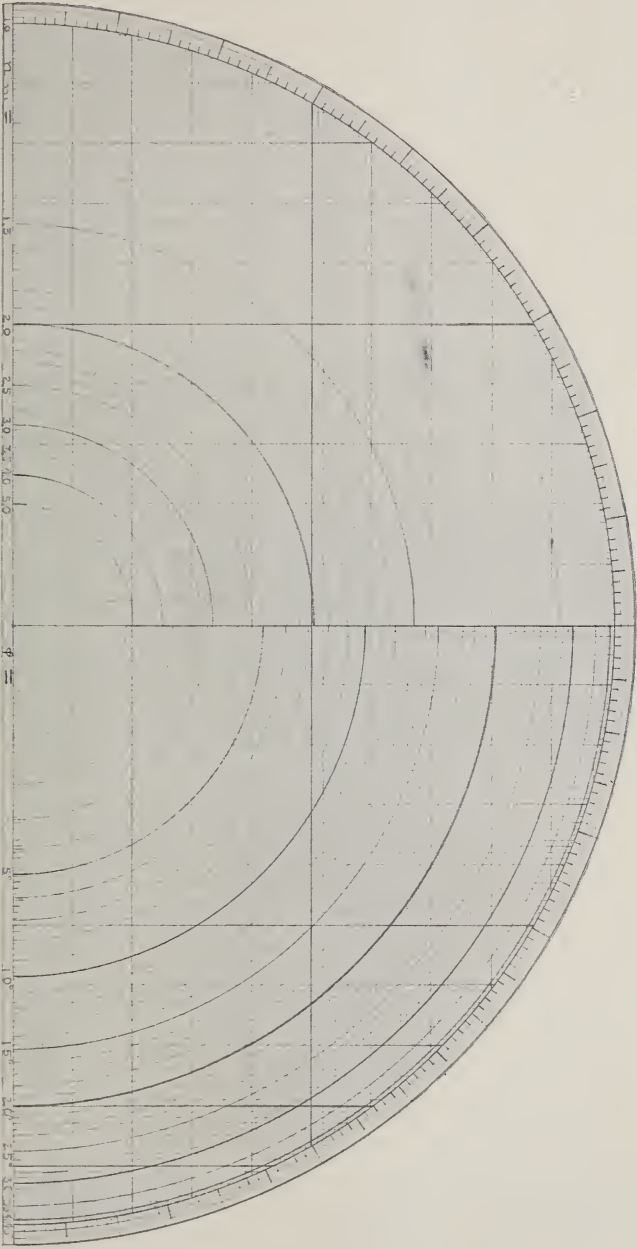

1a

1b

*Bertrand-Mallard method* for measuring the optic axial angle ( $2E$ ) under the microscope. Mallard has shown that the distance of the trace of an optic axis from the center of the interference figure is proportional to the sine of the angle which the optic axis makes with the axis of the microscope; that, if the distance  $D$  be measured by means of a micrometer ocular, the angle  $E$  can be figured from the formula

$$\sin E = \frac{D}{K}$$

in which  $K$  is the constant of the microscope to be determined once for all on a substance whose  $2E$  is known. By drawing a circle of radius  $K$  in fig. 1a (once for all), the angle  $E$  corresponding to any number of divisions of the micrometer ocular is then the angle in the figure included between its base and the radius passing through the intersection of the arc  $K$  with the horizontal line at the distance  $D$  from the base line. To convert  $2E$  into  $2V$  use fig. 1a, which was derived from the formula

$$\sin V = \frac{\sin E}{n_m}$$

$n_m$  being the medium refractive index of the substance. The angle  $2V$  is then the angle on the degree circle included between the base line and the horizontal line which passes through the intersection of the radius  $E$  and the given refractive index arc.

*Michel Lévy method.* Michel Lévy has developed a formula from which approximate values of the axial angle  $2E$  can be calculated, provided the index of refraction of the objective lens in which the interference figure is observed be known. As this, however, is not generally the case, a modification of the formula by introducing Mallard's constant in place of the refractive index is better suited to actual practice.

FIG. 2.

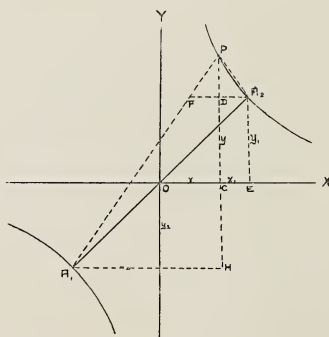

In fig. 2\* let the plane of the paper represent the section perpendicular to the bisector of the acute optic axial angle and the figure itself the achromatic lines observed in convergent polar-

\* Compare Preston, *Theory of Light*, 3d ed., pp. 400-401.

ized light ;  $A_1A_2$ , the projection of the optic axes, and P that of any ray in the achromatic hyperbola. Fresnel's law states that the planes of polarization of rays traveling in any direction P are the bisectors of the angles between the planes  $A_1P$  and  $A_2P$ . For small angles of incidence, the traces of the planes of polarization of the rays will approximately coincide with the bisectors of the angle  $A_1PA_2$ . Since P is a point of the achromatic curve, the bisector of the angle  $A_1PA_2$  must be parallel to one of the principal planes of the nicols. The triangle  $FPA_2$  is then isosceles, and the triangles PFD and  $PDA_2$  are similar. Therefore

$$\frac{x_1 - x}{y - y_1} = \frac{x + x_1}{y + y_1}, \text{ or} \tag{1}$$

$$xy = x_1y_1 \tag{2}$$

the equation of an equilateral hyperbola. In order that this curve be tangent to a circle, its tangent must be perpendicular to the radius the equation for which is

$$y = -\frac{1}{\frac{dy}{dx}} x \tag{3}$$

By substituting the value of  $\frac{dy}{dx}$  from (2), (3) becomes

$$x = y \tag{4}$$

which shows that the hyperbolic curves are tangent to the circles along the diagonals of the nicols. For these points (2) reads

$$x^2 = x_1y_1 \tag{5}$$

Transforming (5) to polar coördinates, we find

$$\rho^2 = r^2 \sin 2\phi \tag{6}$$

From Mallard's method above, it is evident that

$$r = K \sin E$$

and  $\rho = K \sin O$

$$\text{Therefore, } \sin E = \frac{\sin O}{\sqrt{\sin 2\phi}} \tag{7}$$

where sine O is the constant of the circle used and to be determined once for all by the Mallard method. For any given angle of revolution ( $\phi$ ) the corresponding E can be found by finding in fig. 1b the intersection of the horizontal line at the distance sine O from the base line with that arc which corresponds to the angle  $\phi$ . 2E can then be reduced to 2V by fig. 1a, if the medium index of refraction be known.

Owing to the width of the achromatic curves, the results attained by this method are only approximate but of sufficient accuracy to be useful in many instances. The angles  $\phi$  can also be figured for sections not exactly perpendicular to the bisectrix ; they possess, however, only slight practical value.

The mathematical formula above is only an approximate one, while a graphic method can be applied which is theoretically correct and by which more accurate results can be obtained. The method has been used by Michel Lévy, Viola,\* von Fedorow and others in their feldspar studies and is well adapted for general use in the study of optical phenomena.

The lines along which any face will extinguish can be found by passing planes through the normal to the face and the optic axes respectively, and bisecting the traces of these planes on the face. In order to do this readily, a stereographic projection of the optic axes in any desired position should first be made. By a revolution about each of two horizontal axes in the principal planes in the nicols, any face normal can be brought to coincide with the pole of the projection and the face with that of the paper. The bisectors of the angles between the straight lines drawn through the pole of the projection and the optic axes in their new positions are then the desired directions. The achromatic black hyperbolas of the interference figure correspond to those face-normals whose extinction lines are parallel to the axes of revolution of the projection. In the projection the achromatic lines, however, do not appear as they do when observed under the microscope, for its interference figure can be considered with slight error as an orthographic projection of the rays on a sphere, as shown by Mallard's formula above. The curves of the stereographic projection must therefore be replotted by making the polar distance  $\sin E$  instead of  $\tan \frac{E}{2}$  as it is in the stereographic projection. The general aspect of the curves is not changed by this transformation. The graphic method has been applied to the methods below with satisfactory results. (Figs. 4 and 6.)

The interference figure from the section perpendicular to the obtuse bisectrix differs from the above only in the wider optic axial angle, which can be measured by the same methods.

#### *Plate perpendicular to an optic axis.*

The interference figure obtained from this plate consists ordinarily of a black achromatic bar which revolves in a direction opposite to that of the stage. In general the bar is a straight line only when it is parallel to the planes of polarization of the nicols; in the intermediate positions it is more or less convex, depending on the angle between the optic axes. If  $2E$ , however is equal to  $90^\circ$ , the curve is a straight line in all positions for the usual microscopic field of vision.

\* Michel Lévy, *Sur la détermination des feldspaths*, 1894, pp. 15-20. C. Viola, *Zeitschr. für Kryst.*, xxx, 232, xxxi, 484, xxxii, 305. E. von Fedorow, *Zeitschr. für Kryst.*, xxxi, 579, xxxii, 246.

FIG. 3.

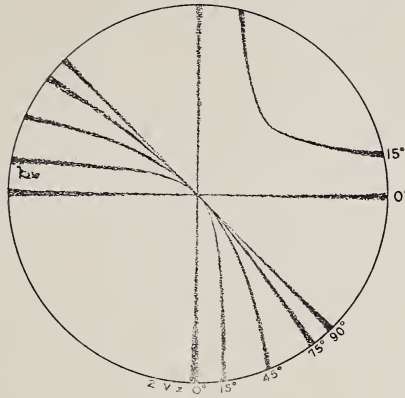
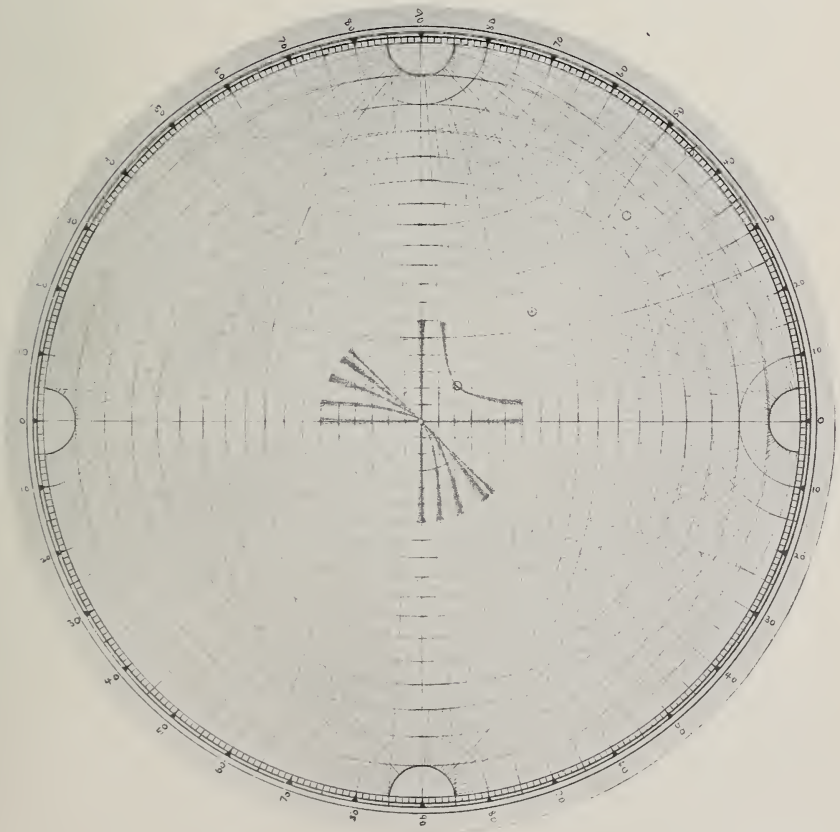

FIG. 4.



An examination of the curves for the several optic axial angles, figs. 3 and 4, indicates clearly that the convex side of the bar in the diagonal position points toward the acute bisectrix. The determination of the optical character is effected then most readily by means of the red of the first order plate. If the achromatic bar of the interference figure be placed in the position of fig. 3 with the convex side of the hyperbola pointing to the northeast and the arrow of the plate (direction of least ellipsoidal axis) also in the same direction, the convex side of the curve will show a blue interference color if the mineral is optically negative; the blue spot will be on the concave side of the curve if it is optically positive.

This method can always be applied if the convexity of the curve can be discerned. In certain plagioclase feldspars, the limiting case of  $2V = 90^\circ$  is encountered occasionally and there the bar is in fact a straight line. For most of the feldspars, however, the curvature is sufficiently marked to enable a determination of their optical character. The result can be checked by extinction angles of the section and adjacent twinning lamellæ after the method of Michel Lévy.

The approximate formula for the achromatic curves from this plate can be derived from a discussion of fig. 5, which is based on assumptions similar to those obtaining for the curves of the plate perpendicular to the acute bisectrix.

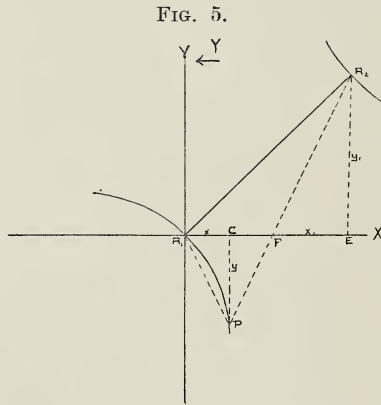

The similar triangles  $A_1PC$  and  $A_2FE$  give at once the relations

$$\frac{x}{y} = \frac{x_1 - 2x}{y_1} \tag{1}$$

$$xy_1 = yx_1 - 2xy \tag{2}$$



the equation of an equilateral hyperbola passing through the zero coördinate point with asymptotes parallel to the X and Y axes. For the special case under consideration where  $x_1 = y_1$ , the formula becomes

$$y = \frac{1}{\frac{1}{x} - \frac{2}{x_1}} \quad (3)$$

From (3) the curves of fig. 3 were plotted in gnomonic projection.

For  $x_1 = \infty$ , equation 3 becomes

$$x = y$$

the equation of a straight line passing through the zero point at an angle of  $45^\circ$  with the coördinate axes. If the formula of Mallard were exact,  $x_1$  could not assume a value greater than 1 (sine  $90^\circ$ ); since it is approximately correct only for small angles, the above remark does not obtain. The gnomonic projection was, therefore used in fig. 3 instead of the orthographic.

In such limiting cases the graphic method gives more satisfactory results and is in general better suited to the study of optical phenomena. In fig. 4, the stereographic plat with curves for optic axial angles  $0^\circ$ ,  $15^\circ$ ,  $45^\circ$ ,  $75^\circ$ , and  $90^\circ$  is given. Their course in the vicinity of the pole of the projection only is represented since it corresponds to that portion which is seen under the microscope.

*Plate parallel to the plane of the optic axes.\**

In the uniaxial minerals this plate corresponds to any section in the prism zone.

The interference figure from the section can be recognized by the fact that in the position of darkness the entire field is practically dark and that a small revolution of the stage ( $5^\circ$ ) will cause the faint hyperbola to recede entirely from the field of vision. In the diagonal position the colored interference curves have the form of hyperbolas.

Since ordinary approximate methods of calculation do not apply to this section, the graphic method with the stereographic projection plat as base was adopted. The result, as depicted by the curves of fig. 6, shows that the recession of the dark achromatic lines for the optic axial angles  $2V=0^\circ$ ,  $10^\circ$ ,  $80^\circ$ , and  $90^\circ$  after a revolution of  $1^\circ$  of the stage is very marked, and that, except in the limiting case of  $2V=90^\circ$ , the dark hyperbolas pass out of the field most slowly in the direction of the acute bisectrix. For  $2V=90^\circ$  the hyperbolas in all quadrants recede from the center with equal rapidity. In fig. 6

\* Compare F. E. Wright, this Journal, xvii, 387-391.

the lines between the outer and inner circles represent the actual position of the bisectrices and optic axes under the conditions stated.

Owing to the fact that for this section the angles of extinction are very low for all rays whose angle of incidence is small, the intensity of the rays adjacent to those of the achromatic curve is also low, since it varies with the square of the sine of

FIG. 6.

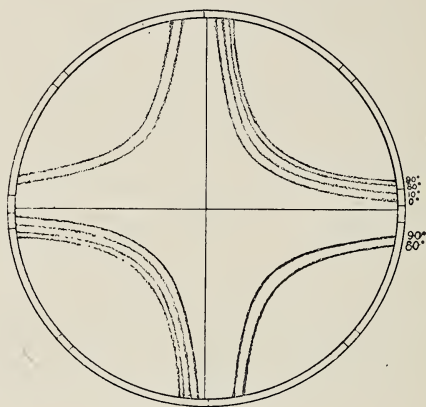

the angle  $\rho$  between the planes of polarization of the nicols and that of the section according to the formula

$$I = \sin^2 2\rho \sin^2 \frac{\pi}{\lambda} (o - e)$$

The black curves are therefore indistinct and require careful scrutiny to be observed at all.

The colored hyperbolic interference curves which appear in the interference figure most sharply in the diagonal position of the section can also be used to locate the direction of the acute bisectrix. It can be proved in several different ways that the acute bisectrix is generally direction of less birefringence than the obtuse bisectrix. The birefringence of any section can be figured approximately by the formula

$$\gamma' - a' = (\gamma - a) \sin \theta_1 \sin \theta_2$$

where  $\gamma'$  and  $a'$  denote the maximum and minimum refractive indices of the given section,  $\gamma$  and  $a$  those of the mineral,  $\theta_1$  and  $\theta_2$  the angles between the normal to the section and the

optic axes respectively. The formula indicates clearly that, except in the limiting case of  $2V=90^\circ$ , the birefringence for sections in the alternate quadrants containing the acute bisectrix is less than that for corresponding sections in the two remaining quadrants. The rule resulting from this fact is that the interference colors for points in the quadrants containing the acute bisectrix are lower than those for corresponding points in the direction of the obtuse bisectrix.

After the direction of the acute bisectrix has been found by one of the above methods, its value ( $c$  or  $a$ ) can be readily ascertained by ordinary methods either in parallel or convergent polarized light.

### Summary.

In the practical determination of minerals under the microscope advantage is taken chiefly of those properties which are definite in character and which can be readily ascertained. Of these the optical character is one of the most useful since it applies to all birefracting minerals and can be determined in convergent polarized light on plates cut along one of several different directions:

1. On plates perpendicular to the acute bisectrix, by observing the direction of movement of the curves of the interference figure on the insertion of a quartz wedge, mica plate, or plate showing the interference color red of the first order. If the loci of the optic axes lie outside of the field, determine whether the plate is perpendicular to the obtuse or acute bisectrix by measuring the optic axial angle in air by the modification of the Michel Lévy method described on page 288. The reduction of the observed optic axial angle to that in the crystal can be accomplished only when the medium refractive index of the substance is known and then easily by fig. 1.

2. On a plate perpendicular to an optic axis by noting that, when the black achromatic bar lies in a position diagonal to that of the principal planes of the nicols, its convex side points toward the acute bisectrix and that on the insertion of a plate showing the interference color red of the first order, the convex side will be colored blue if the arrow ( $n$ ) of the inserted plate lies in the plane of the optic axes and the mineral is optically negative; if the blue spot lies on the concave side of the bar and the arrow of the plate still lies in the plane of the optic axes, the mineral is optically positive. This method is applicable whenever the curvature of the achromatic bar can be observed. The section is moreover easy to find because in parallel polarized light with nicols crossed it remains nearly dark for all positions of the stage.

3. On a plate parallel to the plane of the optic axes the direction of the acute bisectrix can be located by two different methods:

*a.* Revolve mineral from the position of darkness through a small angle and note that the direction in which the faint dark hyperbolas recede from the field is that of the acute bisectrix.

*b.* In the diagonal position of the interference figure observe the interference colors of corresponding points in adjacent quadrants and note that the points in the direction of the acute bisectrix show the lower interference colors. In both cases the value of the acute bisectrix ( $c$  or  $a$ ) can be determined either in convergent or parallel polarized light by the usual methods and thus the optical character of the mineral be ascertained.

U. S. Geological Survey, Washington.

ART. XXXII.—On Groups of Efficient Nuclei in Dust-Free Air; by C. BARUS.

1. *Dust-free Air*.—By this term I refer to atmospheric air filtered with extreme slowness (through large wide filter of packed cotton) and thereafter left without interference for two or more hours. Such air shows a high fog limit. In the fog chamber used the coronal condensation begins at a pressure difference of about  $\delta p = 26$  cm., rain-like condensation at  $\delta p = 21$  cm.

In the present experiments all tests are made at  $\delta p = 41.5$  cm., at a pressure difference therefore much above the fog limit, and probably approaching the condensing power of the apparatus. The number of nuclei computed from the coronas observed is an approximation merely, as the constants needed for the very large range of variation in question are not available. Nevertheless, if the same  $\delta p$  is used throughout, the nucleations obtained are immediately comparable. With these reservations\* the number of nuclei found in the dust-free air and at the  $\delta p$  in question is about  $380 \times 10^3$  to  $400 \times 10^3$  per cm<sup>3</sup>. It is obvious, moreover, that these nuclei are excessively small, much smaller than ions, smaller even than those which would respond to smaller exhaustions, exceeding  $\delta p = 26$  cm.

In figure 1 I have given an example of these relations. Between  $\delta p = 21$  and 26 (for this apparatus) condensation probably takes place largely on ions, above that on the nuclei of dust-free air. The upper dotted line shows the limit of value found, the latter being variable because (as will appear more clearly below) the ionization of atmospheric air is essentially variable. Though relatively small in number, the ions from their larger size probably capture much of the moisture.

2. *Effect of Radium*.—Now let the fog-chamber (fig. 3) be subjected to the radiations from weak radium (10,000 ×, 10 mg.) contained in a thin hermetically sealed aluminum tube. As the walls of the fog-chamber are 3 cm. thick and

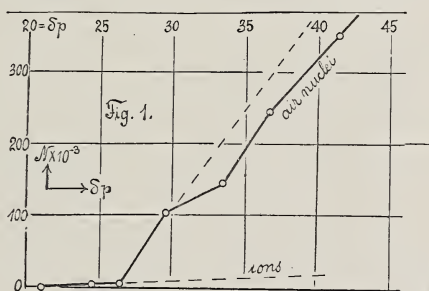

\*The nuclei are supposed to be removed by exhaustion, faster than they can be restored, either by radiation or by the molecular mechanism.

the end (bottom) toward the tube nearly 1 cm. thick,  $\gamma$ -rays only will penetrate into the inside apart from the secondary radiation there produced. In figure 3  $F$  is the cylindrical fog-chamber,  $R$  the radium tube at an axial distance  $D$  from the nearer end. In addition to this the radium was also tested at  $T$  (top) in the figure, where it is nearest the body of dust-free air under experiment.

Within the fog-chamber the coronas are everywhere normal and of the same size, in spite of the axial length of 45 cm. available. This is a singular result when contrasted with the marked positional effect observed for the case of radium placed at the different distances  $D$  outside of the chamber. The data investigated are shown in the curve (fig. 2), where the abscissas are the distances  $D$  and the ordinates the number of *efficient nuclei per cm*<sup>3</sup>.

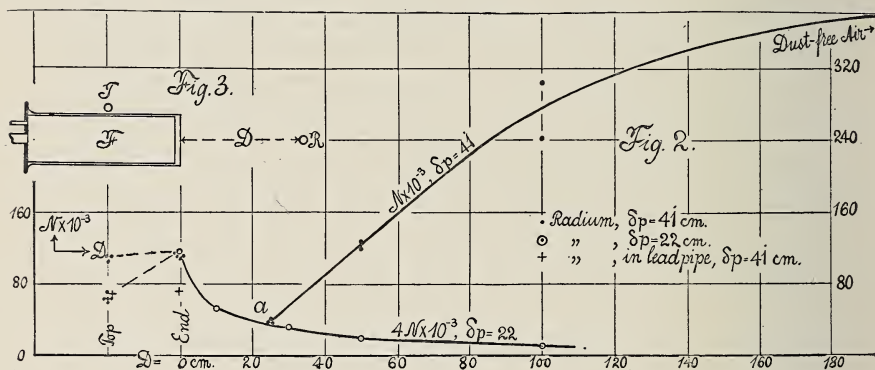

It follows from the graph that as the radium is brought in an axial direction from  $\infty$  to the end of the fog-chamber, the number of efficient nuclei in the dust-free air contained is gradually but enormously reduced to a minimum for  $D = 25$  cm. (about), after which the number again increases to the maximum at  $D = 0$ . Curiously enough, if the radium is further approached to the body of the air by being placed at  $T$ , the number of nuclei does not increase; in some observations it even diminishes.

If the radium is enclosed in a long thick lead tube (60 cm. long, walls .5 cm. thick), the nucleation is but moderately reduced (see fig. 2, crosses), showing that  $\gamma$ -rays are in question.

4. *Cause of the minimum.*—This is easily explained since the ions are relatively large bodies and relatively few in number as compared with the nuclei of dust-free air for the same  $\delta_p$ . Hence the ions virtually capture the moisture more and more fully as their number, with diminishing distance  $D$ , becomes greater. At  $D = 25$  cm. probably the whole of the

moisture is condensed on ions, and as their number increases as  $D$  vanishes, the minimum in question results.

In fact it was shown elsewhere, that below the fog-limit of air, the nucleation observed and due purely to radium at different distances  $D$ , is for example ( $\delta p = 22$ )

$D =$ .....	0	10	30	50	100	
$N \times 10^{-3}$ .....	120	50	32	20	12	etc.

agreeing in character as far as may be expected with the data here in question. These data multiplied by 4, i. e.,  $4n \times 10^{-3}$ , are also given in figure 2 for comparison. Hence the ions caught at  $\delta p = 41.5$  are about four times more numerous than at  $\delta p = 22$ , and correspondingly smaller. They are, therefore, markedly graded, but nevertheless, as a group, throughout much smaller than the nuclei of dust-free air so long as the radiant field is appreciable. Whether the latter are agglomerated under the influence of radiation to make the ions (as would seem more probable), or whether the ions are made from the molecules themselves so that the ions and the nuclei of dust-free air are present together, is a question beyond the scope of the method. While the number of nuclei continually grows smaller, with diminishing  $D$ , the efficient or capturing nuclei may nevertheless increase again below a certain  $D$ , seeing that the nuclei in dust-free air are enormously in excess, only a few of which are caught even in the absence of radium.

4. *Cause of the maximum.*—It is more difficult to account for the result that the same nucleation is observed wherever the radium touches the elongated fog-chamber. In other words, radium at the end of the chamber produces at least the same nucleation as when at the top, although the distances from the center of mass of the glass are as 3 to 1. The same kind of explanation already given in § 3 may possibly hold. The radium tube when placed on the top ( $T$  in figure 3) and in contact with thinner glass, may act with sufficient intensity to admit of the formation in turn of a group of nuclei larger than ions. This is what actually occurs in the case of X-rays. But it is more probably connected with the uniform distribution of nuclei within the chamber (§ 1) and in some way referable to secondary radiation evoked within the chamber. Secondary radiators added on the outside are quite without effect.

5. *General Conclusion.*—The occurrence of a continuous succession of groups or gradations of nuclei in the curve of figure 2, each of which groups constitutes a condition of chemical equilibrium for the given radiating environment, is suggestive. In the first place, it may be recalled that the nuclei of dust-free air are an essential part of this body as much as the molecules themselves. Such nuclei if withdrawn by precipi-

tation are at once restored. Again air left without interference for days shows a maximum of this nucleation for the given conditions of exhaustion when all foreign nucleation must have vanished. Indeed the molecules themselves may be treated as a continuous part of the nucleation in question, the frequency of occurrence being a maximum for the molecular dimensions.

Furthermore in the presence of radium the character of the phenomenon is the same, only the nuclei are larger. If withdrawn by precipitation, they are at once restored. They are an essential part of the air in the new environment.

It is natural to compare the particular nuclear status introduced in the latter case by a particular kind of radiation ( $\gamma$  rays), with the former case of dust-free air in the absence of recognized radiation. In other words, quite apart from the details of the mechanism, chemical agglomeration might be considered referable to an unknown radiant field, but be otherwise essentially alike in kind to the much coarser nucleations observed in the known radiant fields of the above experiments. But the effect of radium, however distant, is always virtually an increase of the size of the air nuclei and a decrease of their number. Hence if we were to fancy that the nucleation (not the ions, of course) of non-energized dust-free air responds to its own radiant environment, this radiation would have to be special in kind.

Returning to the case of the gamma rays, fig. 2, (or of the X-rays coming from a distance,) let me recall that the effective radiation within the fog chamber is everywhere the same and the same in all directions. Hence whether the radiation be corpuscular or (in other cases) undulatory, the interior is nothing less than an ideal Lesage medium; and there must therefore be a tendency at least to agglomerate the colloidal nuclei of dust-free air into fleeting nuclei or ions, so long as the radiation lasts. When it ceases the ions are free to fall apart, so far as external influence goes, as they actually do. Furthermore since the pressure so obtained would increase with the number of corpuscles per cubic cm. and with the square of their velocity, it is conceivable that with increasing electrification this pressure would become strong enough to bring about permanent union of the aggregates, corresponding to the observed continuous transition of the ions into persistent nuclei, produced by the X-rays. Again a different nucleus would presumably correspond to the bombardment of the negative corpuscles as compared with the residual positive quantities. Finally, if any physical or chemical process like combustion or ignition or electric charge, or the case of phosphorus, etc. is accompanied by intense ionization, one would for the same reason anticipate the presence of nuclei in such a field.



ART. XXXIII.—*Studies in the Cyperaceæ*; by THEO. HOLM.  
XXIV. New or little known *Carices* from Northwest America. (With 18 figures, drawn from nature by the author.)

WITH the object of preparing a treatise of the genus *Carex* as represented in the northwestern part of this continent the writer has examined several very extensive collections, containing a vast number of specimens, among which some few have been observed as imperfectly understood or as hitherto undescribed. Inasmuch as the treatment of the genus in a subsequent paper will be from a geographical point of view, we prefer to publish the diagnoses of the new species separately with some remarks upon their affinities.

These species are :

*Carex limnæa* sp. n. (figs. 1-3).

Rhizome vertical with ascending shoots and light brown, fibrillose leaf-sheaths; leaves a little shorter than the culm, narrow, but flat, glaucous, scabrous along the margins; culm about 60<sup>cm</sup> in height, erect or slightly curved above, very slender, triangular, scabrous, phyllopodic; spikes 3 to 5, but mostly 4, the terminal staminate or, sometimes, androgynous, the lateral pistillate, the uppermost contiguous, the lowest remote, sessile to shortly peduncled, erect, not very dense-flowered, cylindric, about 2<sup>cm</sup> in length, subtended by sheathless, foliaceous bracts, the lowest one often exceeding the inflorescence; scale of staminate spike lanceolate, light purplish-brown with green midvein; scale of pistillate spike oblong, obtuse, black with hyaline apex and greenish midvein, shorter than the perigynium; perigynium stipitate, slightly spreading, narrowly elliptical; granular, plano-convex, prominently many-nerved on the outer (convex) face, three-nerved on the inner, pale green with a black, entire and very distinct beak; stigmata 2, style long and exerted.

Oregon: Crater Lake National Park, Cathedral spring, collected by Mr. F. V. Coville, September, 1902 (No. 1456); Four-mile Lake, Klamath County, in meadows, and between Diamond and Crescent Lakes, Cascade Mountains.

The graceful habit of this species reminds us more of *C. rhomboidea* than of *C. vulgaris*, but when we, nevertheless, prefer to place it nearer *C. vulgaris* it is on account of the structure of the perigynium, narrowly elliptical and prominently many-nerved.

*Carex brachypoda* sp. n. (figs. 4–6).

Rhizome short with ascending shoots and persisting, dark brown leaf-sheaths; leaves shorter than the culm, relatively broad (about 5<sup>mm</sup>) and flat, deep green, scabrous along the margins and lower face, glabrous above; culm about 35<sup>cm</sup> in height, erect, stiff, triangular, scabrous, phyllopodic; spikes 3 to 4, mostly 4, the terminal staminate, the lateral pistillate, somewhat remote, sessile or the lowest one short-peduncled, erect, dense-flowered, cylindrical, from 1 to 2<sup>cm</sup> in length, subtended by sheathless bracts with narrow blades much shorter than the inflorescence; scale of staminate spike lanceolate, reddish brown with pale midvein; scale of pistillate spike ovate, obtuse, black with green, not excurrent midvein, a little shorter than the perigynium; perigynium minutely stipitate, erect, almost orbicular, granular and denticulate along the margins above, compressed, nerveless, pale green, the minute beak dark purple with the orifice entire, papillose; stigmata 2.

Oregon: Crater Lake National Park, Cathedral spring, collected by Mr. F. V. Coville, September, 1902 (No. 1455).

The affinity of this species is with *C. gymnoclada*, but it differs from this by the perigynium for instance, which is more roundish, denticulate and very shortly beaked.

*Carex pachystoma* sp. n. (figs. 7–8).

Rhizome caespitose with strong roots and persisting, reddish leaf-sheaths; leaves almost as long as the culm, quite broad and flat (0.5<sup>cm</sup>), glabrous, light green; culm from 30 to 56<sup>cm</sup> in height, erect, somewhat slender, triangular, scabrous, phyllopodic; spikes 4 to 6, the terminal and uppermost lateral staminate, the others pistillate, remote or the uppermost contiguous, all, especially the lower ones, slenderly peduncled, erect or spreading, dense-flowered except at the base, from 3 to 5<sup>cm</sup> in length, subtended by sheathless, leafy bracts about as long as the inflorescence or a little longer; scale of staminate spike lanceolate, obtuse, purplish brown with green midvein; scale of pistillate spike lanceolate, mucronate, deep purple with broad, green midvein, narrower, but longer than the perigynium; perigynium sessile, slightly spreading, elliptical, granular, compressed, nerveless, green or purplish-spotted above, the beak short and thick, sparingly denticulate, the orifice very narrow, slightly emarginate on outer face; stigmata 2.

Oregon: Crater Lake National Park, Anna Creek Canyon, near the falls (No. 1362) and near Odell Lake, Klamath County (No. 520), collected by Messrs. Applegate and Coville.

Washington: Springy places, northern slope of Mt. Adams, and Falcon Valley, W. Klickitat County (No. 2959), by Mr. W. Suksdorf.

The species may be placed between *C. variabilis* and *C. lenticularis*, although it shows some approach to *C. acutina*, though merely in respect to its habit. We have examined a number of specimens and are unable to refer the plant to either of those mentioned above.

*Carex Nebraskensis* Dew.

Habitually and in several other respects this species seems inseparable from the *Microrhynchæ*, but we have placed it\* as one of the most evolute types of these on account of the bidentate beak of the perigynium. It is excellently described by Boott,† and well marked by the strong stolons covered by brown scale-like leaves, which are never shining, by the pale, glaucous leaves and especially by the perigynium with its prominent ribs and bidentate beak. In the extensive collection of Mr. Suksdorf we found several specimens, which were somewhat like this species, but a careful examination of the spikes convinced us that these could not safely be referred to the species, nor ought they to be considered as simply varieties, hence we prefer to describe them as two distinct species: *C. eurycarpa* and *C. oxycarpa*.

*Carex eurycarpa* sp. n. (figs. 9–10).

Rhizome stoloniferous with persisting, brown leaf-sheaths and strong roots; leaves half as long as the culm, narrow (3<sup>mm</sup>), carinate, light green, scabrous along the keel and margins; culm 60<sup>cm</sup> in height, erect, slender but somewhat stiff, scabrous, triangular, phyllopodic; spikes 3 to 5, mostly 5, the terminal and, sometimes, the uppermost lateral staminate, the others purely pistillate, all remote; the pistillate short-peduncled, erect, dense-flowered except towards the base, until 5<sup>cm</sup> in length, cylindric, but relatively thin, subtended by narrow, sheathless bracts, about as long as the inflorescence; scale of staminate spike oblong, obtuse, light brown with pale midvein and narrow, hyaline margins; scale of pistillate spike lanceolate, acute, blackish with pale, not excurrent, midvein, narrower, but about as long as the perigynium; perigynium sessile or nearly so, erect, roundish, granular, slightly planoconvex, prominently many-nerved on both faces, brownish, the beak short, emarginate; stigmata 2.

Washington: W. Klickitat County, Falcon Valley, collected by Mr. W. Suksdorf, June, 1886 (Nos. 1284 and 2962).

*Carex oxycarpa* sp. n. (figs. 11–12).

Rhizome stoloniferous with strong roots and persisting, brown leaf-sheaths; leaves a little shorter than the culm, nar-

\* The author: Greges Caricum. (This Journal, vol. xvi, p. 457, 1903.)

† Ill. gen. *Carex*, vol. iv, p. 175 and plate 592.

row ( $4^{\text{mm}}$ ), carinate, light green, scabrous; culm about  $75^{\text{cm}}$  in height, erect, slender, but somewhat stiff, triangular, scabrous, phyllopodic; spikes 4 to 5, the terminal staminate, long-peduncled, the lateral pistillate, contiguous, seldom remote, short-peduncled, erect, dense-flowered, cylindric, from 2 to  $4^{\text{cm}}$  in length, subtended by sheathless, narrow, foliaceous bracts, the lowest one exceeding the inflorescence; scale of staminate spike oblong, obtuse, light reddish-brown with pale midvein; scale of pistillate spike lanceolate, acute, blackish with pale, not excurrent midvein, narrower, but about as long as the perigynium; perigynium sessile, broadly elliptical, granular, compressed, prominently 3-nerved, brownish, prominently denticulate along the margins from near the base to the short, emarginate beak; stigmata 2.

Washington: W. Klickitat County, meadows near the Columbia, collected by Mr. W. Suksdorf, June, 1885 (No. 816).

Of these *C. eurycarpa* is a very slender plant and much more so than any of the numerous specimens of *C. Nebraskensis*, which we have studied. The broad perigynium with the beak merely emarginate constitutes, also, a good distinction. In the other, *C. oxycarpa*, we have, also, a plant of slender habit, but the spikes are relatively heavy, and the perigynium is here merely 3-nerved and with the margins quite prominently denticulate from the base to the emarginate beak.

The affinity of these two species is unquestionably with *C. Nebraskensis* Dew., next to which they should be placed in the system.

*Carex campylocarpa* sp. n. (figs. 13–15).

Rhizome with short stolons and purplish, persisting leaf-sheaths; leaves shorter than the culm, narrow, but flat, scabrous along the margins and on the lower face; culm about  $40^{\text{cm}}$  in height, erect, stiff, triangular, scabrous, phyllopodic; spikes 3 to 4, mostly 3, the terminal staminate, the lateral pistillate; remote, sessile or nearly so, erect, dense-flowered, short cylindric to ovoid, from  $\frac{1}{2}$  to  $1^{\text{cm}}$  in length, subtended by sheathless, foliaceous bracts, shorter than the inflorescence; scale of staminate spike lanceolate, obtuse, purplish brown with pale midvein; scale of pistillate spike ovate, obtuse, blackish with the midvein faintly visible and the margins narrow, hyaline, much shorter than the perigynium; perigynium shortly stipitate, spreading, elliptical-oblong, granular and prominently denticulate along the upper margins, turgid, nerveless, pale green with purplish spots and streaks, the beak quite prominent, excurved, the orifice entire; stigmata 2, style not exerted.

Oregon: Crater Lake National Park, Cathedral spring, collected by Mr. F. V. Coville, September, 1902 (No. 1457).

The systematic position of this species seems naturally to be among the *Microrhyncheæ*, but as a deviating type on account of the excurved beak of the perigynium, and if it were not for the distinct marginal denticulation of the perigynium and its slender shape the species would resemble *C. scopulorum* to some extent. A perigynium of this kind is somewhat unusual within the representatives of the grex, but is, as we remember, very characteristic of the *Spirostachyæ*; in these, however, the beak is generally bifid and more distinctly differentiated from the body. The species may be placed next to *C. scopulorum*.

*Carex cryptochlæna* sp. n. (fig. 16).

Rhizome cæspitose with purplish, persisting leaf-sheaths; leaves about half as long as the culm, broad (about 1<sup>cm</sup>) and flat, glabrous except along the margins; culm from 70 to 90<sup>cm</sup> in height, erect and stiff, triangular, scabrous along the edges, phyllopodic; spikes from 4 to 7, the terminal and frequently the uppermost lateral staminate, the others pistillate or androgynous, contiguous or the lower ones remote, sessile or short-peduncled, erect or spreading, seldom nodding, dense-flowered, subtended by sheathless, foliaceous, broad bracts of which the lower ones exceed the inflorescence; scale of staminate spike elliptical-oblong, acute, light reddish-brown with pale midvein; scale of pistillate spike lanceolate, sharply pointed, deep purplish with broad, greenish midvein, exceeding the perigynium; perigynium almost sessile, erect, broadly elliptic to roundish, nerveless, pale green, granular, sparingly denticulate near the minute, entire beak; stigmata 2.

Alaska: Kussiloff, on sands with *Elymus*, collected by Dr. Walter H. Evans, July, 1898 (No. 618), and Seldovia near mouth of Cook inlet by Prof. C. V. Piper, August, 1904 (Nos. 4818 and 4819).

This species is somewhat remarkable on account of its resemblance to *Carex cryptocarpa*, so far as concerns the structure of the spikes, the deep-purplish, lanceolate scales and the broad pale-green perigynia. But it shows, on the other hand, a striking contrast to this species, *C. cryptocarpa*, not only by the almost sessile and mostly erect pistillate spikes, but also by its very broad leaves, the basal and the bracts. Habitually the species does not resemble *C. cryptocarpa*, but, to some extent, Drejer's *C. hæmatolepis* or certain very robust forms of *C. salina*; it appears, however, to be distinct from these, and as a type intermediate between the true *Salina* and *C. cryptocarpa* Mey.

*Carex luzulæfolia* W. Boott var. *strobilantha* nob. (fig. 18).

Taller and more robust than the typical plant; the spikes thick and very compact-flowered; scales of staminate and pistil-

late spikes mostly mucronate; perigynium glabrous throughout, faintly nerved on the inner face, nearly sessile, roundish in outline and terminated by a very distinct, bidentate beak.

California: Above Donner Pass in Placer County, in a subalpine meadow, where snow-drifts lie late, and usually near granite rocks, collected by Mr. A. A. Heller, August, 1903 (No. 7187).

In the specimens of this new variety the rhizome is densely matted with ascending shoots and covered by dark, brownish fibers from the old leaf-sheaths. The leaves are very broad, but much shorter than the culms. The heavy, deep-brown spikes remind of small cones, hence the name "*strobilantha*," and there is quite a variation in respect to their number, position and the distribution of the sexes. We noticed the following instances in 26 specimens:

2 staminate and 3 pistillate spikes in 14 specimens.	
1	" 3 " " 5 "
2	" 4 " " 2 "
1	" 4 " " 2 "
2	" 2 " " 1 "
3	" 3 " " 1 "
3	" 1 androgynous " 1 "

In some specimens the pistillate spikes were borne on very long peduncles overtopping the terminal, and several of these were observed to be more or less decompound.—The structure of the perigynium is very characteristic and differs essentially from that of the typical plant, which, as described by W. Boott,\* is: "oval to lanceolate," "slenderly nerved, slightly serrate on the upper margins, longer and broader than the scale." The accompanying figures of the perigynia show the distinction very plainly, a distinction, however, which appears to the writer as merely varietal.

Brookland, D. C., May, 1905.

\* S. Watson: *Botany of California*, vol. 2, p. 250, 1880.

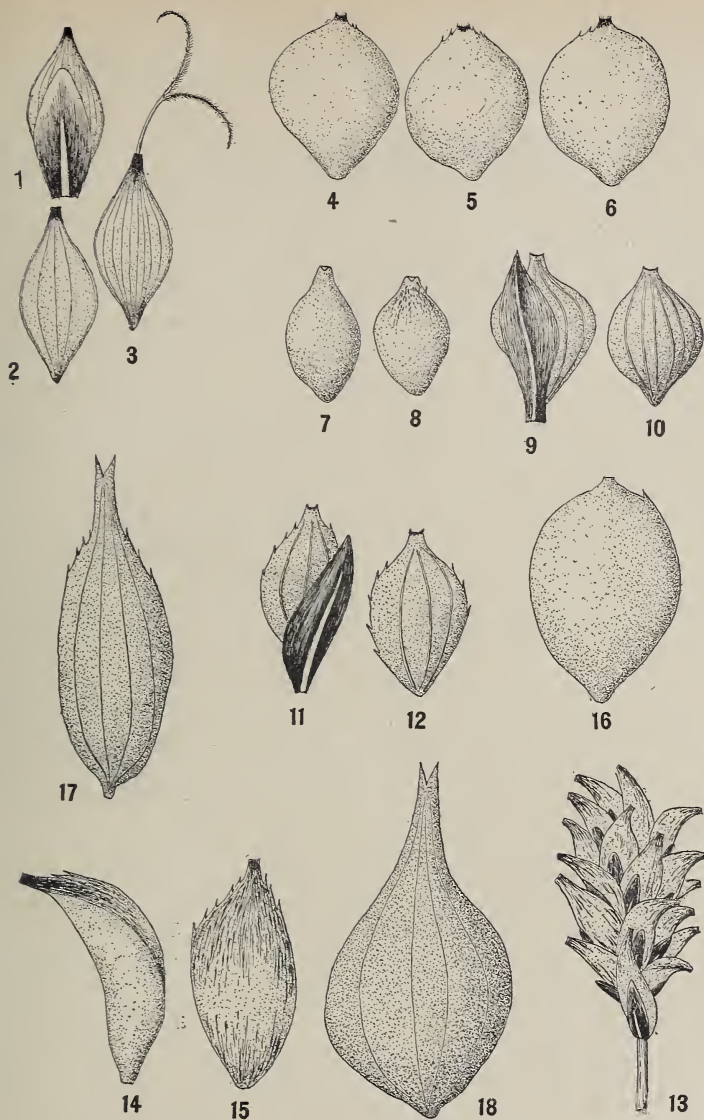

FIGURE 1. Perigynium and scale of *Carex limnaea*.  
 " 2. Perigynium of same, inner face.  
 " 3. Perigynium of same, outer face.  
 " 4-6. Perigynium of *Carex brachypoda*, outer face.  
 " 7, 8. Perigynium of *Carex pachystoma*, outer face.  
 " 9. Perigynium and scale of *Carex eurycarpa*.  
 " 10. Perigynium of same, outer face.  
 " 11. Perigynium and scale of *Carex oxycarpa*.  
 " 12. Perigynium of same, outer face.  
 " 13. Pistillate spike of *Carex campylocarpa*.  
 " 14. Perigynium of same, side view.  
 " 15. Same, outer face.  
 " 16. Perigynium of *Carex cryptochlœna*, outer face.  
 " 17. Perigynium of *Carex luzulefolia*, outer face.  
 " 18. Perigynium of *C. luzulefolia* var. *strobilantha*, inner face.

All figures magnified.

ART. XXXIV.—*Preliminary Note on some Overthrust Faults in Central New York*; by PHILIP F. SCHNEIDER.

MY attention was recently called to two unrecorded overthrusts in the limestones of this vicinity by Mr. Charles E. Wheelock, who discovered the same, and at whose request this preliminary notice has been prepared. In company with Mr. Wheelock the writer recently visited the locality and this description is largely confirmatory of Mr. Wheelock's observations, which will be given in full in a future paper.

These disturbances in the horizontally stratified Paleozoic rocks of central New York, where for so many years it was thought they could not exist and where the first announcements of such occurrences were received with such incredulity, are not yet sufficiently common to permit them to pass unrecorded. The faults are furthermore important because of the relation between them and the well known peridotite intrusives and the probability of the identity of the causes producing the same.

Both of the faults brought to light by Mr. Wheelock occur in some thinly bedded limestones which he correlates with the Bertie dolomite as described by Clarke in his recent report on the formations in the Tully Quadrangle,\* or with the lower layers of the Waterlime of Vanuxem,† Geddes,‡ Schneider,§ and Luther.||

The faults can be easily studied in the gorge of Butternut Creek, near Dunlop's station, one and one-quarter miles north of Jamesville. In the east cliff, a few yards to the south of the stairs leading from Fiddler's Green to the gorge of the creek, the thrust plane of the southernmost of the faults (Fault IV. Dunlop's) can be easily distinguished as it extends upward from the base of the cliff through its entire height, a distance of nearly thirty feet. At this point the cliff is comparatively free from talus. The dip of the fault plane is 28° to the northeast, N. 40° W. This northerly dip of the thrust planes of both of the faults located by Mr. Wheelock is interesting inasmuch as they seem to belong to a series of faults extending in an east and west direction across the country, which had to the southward.¶ It is furthermore surprising as they occur about mid-

\* Bulletin 82, N. Y. State Museum, 1905, J. M. Clarke.

† Rept. 3d Dist. N. Y. 1842.

‡ Geol. Survey of Onon., Rept. N. Y. State Agricultural Society, 1859.

§ Notes on Geol. of Onondaga Co., N. Y. 1893.

|| Econ. Geol. of Onon., 15th Ann. Rept. N. Y. State Geol. 1895.

¶ This refers to the overthrusts in the Helderberg limestone series only and not to the slips and slides which are so common in or near the gypsum beds, and which can be explained by the expansion due to the formation of the gypsum, or to the solution of the gypsum or salt immediately underneath.



way between Gifford's and Russell's faults, the two disturbances showing the greatest amount of displacement and practically in a straight line with them. The layers have been sharply bent along both sides of the thrust plane and secondary crystals of calcite have been formed in the numerous fractures in and between the layers, but not as abundantly as at East Onondaga and Marcellus. Mr. Wheelock believes the amount of displacement is about four feet, but it is impossible to determine the thrust accurately because of the marked similarity of the layers of limestone.

The continuation of this fault may be seen in the west wall of the gorge, where it is not as easily accessible nor as readily studied because of the accumulated material. The bending and buckling of the layers is even more pronounced here than on the east side of the stream, although the displacement was apparently less.

Following the direction of the fault to the eastward, a cut on the trolley line just north of Dunlop's station is reached, showing some disturbance and a marked anticlinal fold. The fractured and disturbed condition of the layers in the entire cut and especially at the fold, which is directly in the line of the strike of the fault, makes it difficult to determine whether the faulting has reached upward to this point. The fracturing and shattering of the layers resembles somewhat that produced in certain of the layers overlying the gypsum, and lends color to the belief that Fiddler's Green marks the position of the gypsum deposit. A study of the gypsum ledge to the north-eastward indicates that the gypsum occurs either just above or just below the cut showing the shattered layers, while a comparison of the altitudes of the adjoining gypsum deposits shows that it should occur at the Fiddler Green locality. Nevertheless it has not yet been noted there. However, the gorge of the creek lies below Fiddler's Green, hence it is hardly possible that the faults just described can occur in the Bertie limestone which is described by Clarke as overlying the gypsum. However, according to Clarke's map the Bertie occurs in the gorge of the creek at this point.

*Fault III. Dunlop's.*—Following the gorge to the northward for a hundred yards or more, the folding and buckling of the layers give evidence of another disturbance. At this point the force seems to have exerted itself mainly in the bending of the layers, and without any large amount of displacement. The thrust plane of the fault is plainly visible, dipping at an angle of  $23^{\circ}$  to the northward. The displacement is not more than two feet. Fault III occurs in the same formation as that already described, the Bertie dolomite (?) The fault cannot be seen on the west side of the gorge because of a change in the

course of the stream here, which change in the direction is no doubt due in part at least to the existence of the fault right here.

*Fault I. Dunlop's.*—In making a cutting for Jamesville branch of the Suburban railroad about two years ago, two somewhat similar faults were exposed in the calcareous layers occurring three-eighths of a mile farther north. These layers may be continuously traced to the northeastward until they are found underlying the gypsum. They undoubtedly correspond with the limestone ledge mentioned by Clarke as containing the *Leperditia Scalaris* Jones, which occurs in the Camillus shale near the base of the Heard gypsum quarries. Inasmuch as there is only a difference of five feet in elevation between the altitude of these layers at faults I and II and faults III and IV with practically horizontal layers between the localities, it leaves little question but that faults III and IV occur in this same *Leperditia Scalaris* limestone and not in the Bertie. Fault No. I may be seen in the first cut showing the limestone, which is about 150 yards south of the crossing of the trolley and the Jamesville and Orville turnpike. The thrust plane of the fault cuts these somewhat thinly laminated layers, and dips at an angle of  $35^{\circ}$  to the south. The layers show little disturbance except at the fault line. Secondary calcite crystals occur in the fractures of the limestone, near the fault.

*Fault II. Dunlop's.*—Occurs in the same formation and in practically the same layers twenty yards south of fault No. I. The thrust plane dips south  $32^{\circ}$  and the layers are bent for several yards to the southward. The slickensided surfaces are well shown, also a slight tendency toward slaty fracture. Calcite crystals are lacking. The displacement is slight, probably not more than three feet. The fault maintains its character throughout the entire height of the cut. Owing to an accumulation of talus and the dense vegetable growth the faults have not been located on the west side of the stream.

Other evidences of slight faulting are noticeable farther north in this cut, also some shearing of the layers with the formation of calcite crystals.

The overthrusts now known and described in central New York are—

(a) Russell's Quarry at East Onondaga, fault plane cuts the Manlius, Lower Helderberg, Oriskany, and Onondaga formations. Displacement forty-two feet. Also shown in Hibbard's and adjoining quarries. Rocks affected for over a mile to the eastward as shown by the marked slaty cleavage in the finer grained limestones of the Corniferous.

Luther, "Econ. Geol. of Onon.," 15th Ann. Rept. N. Y.

State Geologist, 1895. Schneider "Science Series, No. 2.," Onon. Acad. Science publication, 1899.

(b) Maylie's Quarry at Marcellus, cuts Corniferous and Seneca layers of the Onondaga. Displacement, three feet. Shown in adjoining quarries for over one-half mile to westward. Thrust plane dips  $17^{\circ}$  to N. See preceding references.

(c) Gifford's Glen, two miles west of Manlius. Cuts the Onondaga and Marcellus groups. Decidedly interesting because of the remarkable manner in which the heavy layers of Onondaga limestone have been arched and bent. Thrust plane not visible. Luther makes the elevation of the limestone sixty feet, but says it is due to bending.

(d) Fillmore's Corners, one-half mile west of preceding. Cuts Onondaga and Marcellus groups. Displacement, fifteen feet. "Geological Fault at Jamesville," Schneider. This Journal, vol. iii, 1897.

(e) Indian Reservation Quarries. Two faults cut Onondaga formation. Dip  $23^{\circ}$  S. Total displacement of the several faults about six feet. Schneider, "Science Series No. IV.," Onon. Acad. Sci. 1905.

(f) Dunlop, No. I, cuts *Scalaris* limestone in *Camillus* shale. Displacement, three feet. Dip,  $35^{\circ}$  S.

(g) Dunlop, No II, *Scalaris* limestone. Displacement, three feet. Dip,  $32^{\circ}$  S.

(h) Dunlop, No. III, cuts *Bertie dolomite* (?) Displacement, two feet. Dip,  $23^{\circ}$  N.

(i) Dunlop, No. IV, *Bertie dolomite* (?) Displacement, four feet. Dip,  $28^{\circ}$  N. E.

(j) Heard's gypsum quarry. A small overthrust in the *Camillus* shale occurs here, apparently more deeply seated than the displacements so common in the gypsum quarries due to the formation and subsequent solution of the gypsum.

The writer also has MS. notes and drawings of several small faults occurring in the *Camillus* shale near the *peridotite* dikes which were temporarily exposed during the trenching of that region for city water.

At the *Solvay* quarries at *Split Rock* in the *Manlius* and *Onondaga* formations and in some of the adjoining abandoned quarries several sharp folds and some slickensided surfaces occur which tell of further disturbances. Similar evidences occur in *Madison Co.* in the vicinity of *Chittenango Falls* to the east of the described localities, while to the westward they may be seen in the same ledge about *Auburn* in *Cayuga Co.* *Cleland\** mentions a fault in the outlet of *Keuka Lake*, still far-

\* "A Study of the Fauna of *Hamilton* formation of the *Cayuga Lake* section in central New York," H. F. *Cleland*, Bulletin No. 206, U. S. Geol. Survey.

ther west, but no facts are given, while the folds in the higher formations are well shown in long arch at Cayuga Lake, and similar undulations in strata at Seneca. Disturbances are also noted by Lincoln in his account of the geology of Seneca Co.\*

Inasmuch as most of the above mentioned disturbances occur in or near the Helderberg escarpment, composed in the main of heavy limestones aggregating several hundred feet in thickness, and the persistence of the faults across central New York, it would seem that all are the result of some considerable force capable of affecting this entire region. In a general way the solution of the salt from the Salina formation which immediately underlies the Helderberg series has been regarded as an explanation for all the disturbances in this vicinity. Mr. Wheelock believes that the solution of all of the saline ingredients of the Salina rocks together with the slight dip of rocks of central New York is a sufficient explanation for the faulting, as any settling of the layers must shorten the length of the hypotenuse of the triangle and thus produce the force which crumpled and fractured the rocks. The fact that the softer shales sandwiched between the limestone bands are sometimes bent and sheared while the harder layers are not affected, and that the larger throws all occur in the more resistant layers, he believes will favor his explanation. This, however, would be true irrespective of the cause, provided of course that it were compression. It has also been suggested† that expansion due to the formation of gypsum would explain the faulting. While considering the causes of the faults it would be well to keep in mind that there is a series of widely known intrusives which parallel north and south this series of faults, and which extend across the state from Little Falls on the east to Ithaca on the west, and it is not impossible that both faults and dikes owe their origin to the same general disturbance. The consideration of this question, however, will be left to another paper.

Syracuse, N. Y.

\* "Geol. of Seneca Co.," Rept. N. Y. State Geologist, 1894.

† E. H. Kraus, verbally.

ART. XXXV.—*Petrography of the Tucson Mountains, Pima Co., Arizona*; by F. N. GUILD, University of Arizona. (With Plate IX.)

THE Tucson Range of mountains is located directly west of Tucson and is about twenty miles long with an average width of about seven miles. It consists of a series of jagged peaks extending nearly north and south, the higher ones of which are estimated to have an altitude of 4000 feet above sea level. The approach to the main line of peaks is over a series of low-lying rounded knolls devoid of all vegetation except a few cacti and other stunted growths characteristic of an arid region.

Petrographically quite a variety of rocks are represented which are almost entirely eruptive. There occur, however, in places, remnants of the original quartzites and limestones through which this great mass of lava has broken. On the west side of the range and southwest of Tucson is an elevated plateau of an area of one hundred square miles or more, consisting entirely of these limestones and quartzites. It is quite level and the beds are exposed only along its edges and near the center where the uplifted strata form two small buttes, consisting almost entirely of crystalline limestone tilted to an angle of about forty-five degrees.

It is the purpose of this paper to describe from a petrographical standpoint the eruptive rocks without discussing their geological relations. The question of names and classification is not taken up, the writer considering descriptions of more importance. With this introduction, they will be described in the order of their relative abundance.

*Rhyolite*.—The main line of jagged peaks referred to above is made up of this rock, varying in color from a dark red to nearly white. Phenocrysts are inconspicuous, not very abundant and rarely exceed three millimeters in diameter. They consist of quartz and less abundant orthoclase. Under the microscope, the quartz is found to occur in rounded masses corroded by the groundmass with frequent inclusions of the latter in the form of bag-shaped inlets. Black dust-like inclusions and glass with gas bubbles are common. The feldspar, although much decomposed and containing opaque inclusions, still shows the characteristic cleavage of orthoclase. The groundmass in the darker varieties is too much altered to show any characteristic texture. In the southern portion of the district, however, material is sometimes met with of sufficient freshness to admit of satisfactory study, and here it is found to have a cryptocrystalline structure. Specimens of it are frequently found possessing faint flow lines, sometimes vis-

ible to the unaided eye, but usually requiring a microscope to be seen. (Fig. 1, Plate IX.) Occasionally dark shredded masses occur which may have been originally mica. All varieties contain irregular inclusions of varying size, sometimes two inches across, of a red jasper-like substance or of sandstone or quartzite. Frequently also rounded patches are met with which under the microscope are found to be made up of quartz and feldspar in equidimensional crystals, which may represent areas of more complete crystallization of the groundmass.

Associated with these more typical rhyolites are large masses usually of a light yellow to buff color, lacking all phenocrysts. They correspond to rocks which have been variously called felsite, felsophyre, granophyre, etc. They sometimes break with conchoidal fracture, but are more often too coarse-grained to show this characteristic. Under the microscope, quartz, feldspar and sometimes shreds of mica can be seen in the coarser varieties. The finer-grained types are made up entirely of cryptocrystalline material in which none of the constituents can be determined.

*Rhyolitic Tuff.*—Associated with the outflow forming the main rhyolite peaks, there were probably formed masses of volcanic ash. The greater portions of this have been washed away, but occasionally where geological conditions have been favorable some of this material has become consolidated into a compact rock of light gray color of sufficient strength to be used extensively in building. Underlying Sentinel Peak in places there are small masses of it which have been held in place by the basaltic outflow. Under the microscope it is found to be made up of fragments of quartz, feldspar, glass, etc. It is interesting to note that the quartz has the same kind of inclusions as the quartz phenocrysts in the rhyolite described above.

*Andesites.*—Several types of this rock varying greatly in appearance and texture occur. They may be grouped rather roughly as follows:

1. Light-colored andesites containing phenocrysts of mica or hornblende or both and of feldspar.
2. Dark-colored andesites of non-porphyritic texture.
3. Vitrophyric andesites.

The first variety covers an area only slightly less in extent than the rhyolites and constitutes the material of the low-lying knolls previously referred to. It has usually a mottled appearance not unlike that of some granites. The feldspar is pure white and the groundmass varies from white to greenish gray. The chief variation is in the black ferro-magnesian minerals, which are most often biotite, but in some localities hornblende predominates, while in still others the black phenocrysts are quite inconspicuous. Under the microscope the feldspar is clear,

usually striated, and as shown by the extinction angles on the twinning plane appears to be an acid plagioclase. The biotite is quite fresh and of the usual dark yellow-brown color. Hornblende has become darkened by alteration and is often quite opaque. The groundmass is crystalline and made up mostly of feldspar with some magnetite and shreds of the dark silicates.

The second variety is found in the northern portion of the district near the edge of the mountains about twelve miles from Tucson. It varies greatly in both megascopic and microscopic structure in different parts of the same mass. Its general appearance is more like that of a diabase except in portions where phenocrysts of feldspar appear. It is very dark with a slight green tinge weathering red. Porphyritic texture is not conspicuous and may be megascopically absent. Under the microscope, however, the rock is found to consist of crystals of plagioclase, pyroxene, and biotite in a variable groundmass. In some portions the distinction between groundmass and phenocrysts is very marked, the groundmass being typically andesitic, while in other parts there is comparatively little difference in size between the constituents of the groundmass and the phenocrysts. The pyroxene is light yellow-green in color with high extinction angle and non-pleochroic and rarely occurs in crystals longer than one millimeter. The plagioclase phenocrysts are usually somewhat larger, ordinarily clear but sometimes opaque from decomposition. The biotite appears in rather small crystals compared with the other phenocrysts and is of a light yellow-brown color with darker borders. In altered specimens the dark-colored constituents have decomposed into yellow non-pleochroic masses.

The third variety, or vitrophyric andesite, is also found in the northern portion of the district as a low rounded ridge not more than one hundred feet above the surrounding country. It is also a pyroxene mica andesite, and is distinctly porphyritic, the phenocrysts occupying fully one half of the entire mass of the rock. Black mica and feldspar are very conspicuous and occasionally orthoclase crystals eight millimeters in length showing well-formed Carlsbad twins occur. The groundmass varies from a nearly black to light gray transparent glass. Under the microscope the feldspar is found to be of plagioclase and of an unstriated variety. It frequently possesses zonal structure and is often much broken, appearing in angular fragments. The biotite is in fresh hexagonal plates and irregular shreds. Pyroxene is light green and shows high extinction angle. Magnetite is present in the usual quantities. The groundmass is isotropic and filled with what appear to be small fragments of the phenocrysts and very small crystallites.

Fine flow-lines and perlitic cracks occur in places. This variety of andesite is very common in southern Arizona and frequently possesses flow-lines of remarkable beauty. (Fig. 2.) In the upper part of the andesite the groundmass has become entirely opaque through devitrification.

*Basalt.*—Outflows of this rock occur at various intervals along the edges of the mountain range especially west and south of Tucson. They vary greatly in character and may be grouped into the following varieties:

1. Fine-grained olivine basalt.
2. Porphyritic basalt.
  - a. Containing phenocrysts of feldspar and augite, in a coarse-grained or doleritic groundmass.
  - b. Containing porphyritic crystals of feldspar only in a basaltic groundmass.
  - c. Containing feldspar, augite and olivine in an andesitic groundmass.
3. Quartz basalt.

One of the most prominent of these basaltic outflows is one mile west of Tucson in the form of a symmetrical cone-shaped mass called Sentinel Peak. Immediately northwest of this is another irregular dome-shaped mass of the same rock. It is further represented in two promontory-shaped outflows southwest of the San Xavier Mission and ten miles south of Tucson. These elevations are made up chiefly of the fine-grained type of basalt in which none of the constituents can be recognized with the naked eye. It is usually compact and free from cavities, but occasionally is found quite cellular and even scoriaceous in structure. The cavities are sometimes rounded in outline with a diameter of one half inch or more, but are more often drawn out by movements of the mass when in a molten condition into irregular channels. These cavities are usually empty, but are sometimes filled with gypsum or aragonite. The predominating color is black, but deep red varieties are met with, especially in the San Xavier outflow. In places pressure and movement of the mass have developed a schistose structure, the laminations frequently being nearly vertical. This is especially noticeable on the dome-shaped mountain mentioned above near the Carnegie Desert Botanical Laboratory, and leads to the conjecture that the vent through which the basalt escaped is located under it.

Microscopically the rock is made up of numerous feldspar rods crowded together and frequently arranged in flow-lines, large amounts of magnetite and rather small quantities of olivine. Glass is present in greatly varying quantities. The olivine occurs mostly in rounded grains with a dark red halo



of ferritic material and occasionally the interior of the crystal has been reabsorbed leaving skeletons filled by the groundmass. (Fig. 3.) The accompanying illustrations (figs. 3, 4) will show the most important variation in this type of basalt. In fig. 4 the constituents are more porphyritically dispersed than is usual in these outflows and the groundmass contains more isotropic material, yet to the unaided eye they all appear nearly identical.

Porphyritic basalt of the first type (*a*) is found underlying the compact basalt of Sentinel Peak at its southern extremity. That this represents an outflow distinct from the compact variety is shown by the sharp contact between the two, where there is a layer of dark red basaltic tuff and breccia from two to six feet thick. A rock practically identical with this is found at the San Xavier Mission in a small cone-shaped elevation. This variety appears to be made up of large plagioclase crystals constituting nearly one half of the mass, and frequent black lustrous crystals of augite in a groundmass varying from coarse crystalline to compact. The feldspar crystals are sometimes over one half inch in length and frequently broken. Under the microscope they are found to be quite fresh, twinned plagioclase filled with dark inclusions of the groundmass. The pyroxene is light yellow with parallel cleavage cracks and high extinction angle. The groundmass, where it can be made out with the microscope, is mostly feldspar and augite with but small amounts of glass. Olivine is not at all abundant and in some slides is absent. (Fig. 5.)

The second type of porphyritic basalt (*b*) is found as occasional outflows south of Sentinel Peak, the largest yet observed being about seven miles from Tucson. The color of the rock is medium dark gray, and the only minerals which can be determined in it by the naked eye are feldspar and occasionally magnetite. The feldspar is rarely over one quarter inch in length and is more rod-shaped than in the foregoing type. It becomes very conspicuous only as the rock weathers. Under the microscope the feldspar is like that in the first type. The groundmass can hardly be resolved by the microscope but seems to consist mostly of feldspathic material and magnetite.

The third type of porphyritic basalt (*c*) occurs in a very small mass not more than one hundred feet in length at the southern base of Sentinel Peak. Portions of the mass are amygdaloidal and much decomposed. The amygdules are sometimes six inches in diameter and filled with agate, usually in concentric rings of varying translucency, or with calcite or siderite. Sometimes there is an outer shell of agate, the interior being filled with calcite. Geodes of brilliant smoky quartz have also been found. In places the rock is sufficiently

fresh for satisfactory study. To the naked eye the porphyritic character of the rock is not at all apparent. Under the microscope, however, it is found to be made up of distinct porphyritic crystals of abundant feldspar, considerable pyroxene, and much less olivine in a semicrystalline groundmass consisting of a felt of magnetite and dark matter which reacts feebly under polarized light.

*Quartz basalt.*—This unusual type of basalt is found in the extreme southern end of the mountain range as a portion of the promontory-shaped hill two miles southwest of the San Xavier Mission. The greater portion of the outflow consists of the compact basalt already described with cellular and scoriaceous modifications. On the extreme eastern slope an abundance of the quartz-bearing variety appears. Quartz is the only mineral that can be detected with the naked eye. Aside from this porphyritic constituent the general character of the rock from both a megascopic and microscopic standpoint is the same as the compact varieties described above. The quartz occurs as rounded and semi-angular grains, rarely more than six millimeters in length. Under the microscope the quartz appears clear, much fractured and quite free from inclusions of all sorts. That the quartz is primary and not due to secondary filling of cavities is inferred from the fact that the grains each consist of but one individual as shown by the extinction. This is not the case where previously existing cavities have been filled by infiltration. Amygdaloidal fillings have been observed in this same rock and they present a structure quite different from the quartz in question. Basalts containing quartz have been described by Diller,\* Iddings† and Pirsson‡ from various localities in the United States, and by Andreae§ and Lacroix|| from other regions. By most of these writers their origin has been discussed and they have been held to be of primary origin. Some, like Lacroix, have, however held them to be inclusions, quartz grains caught up from lower rocks and held in the magma.

#### DESCRIPTION OF FIGURES, PLATE IX.

FIGURE 1.—Rhyolite, showing flow-lines in the groundmass, ordinary light, 18 diameters.

FIGURE 2.—Vitrophyric andesite, near Gila Bend.

FIGURE 3.—Basalt, Sentinel Peak, 45 diameters.

FIGURE 4.—Basalt, near San Xavier, 45 diameters.

FIGURE 5.—Porphyritic basalt, showing crystals of augite, 18 diameters.

FIGURE 6.—Agate, under polarized light, showing complicated structure, found as amygdaloidal filling in porphyritic basalt (c), 45 diameters.

\* This Journal, vol. xxxiii, p. 45, 1887. Bull. U. S. Geol. Surv. 79, 1891.

† This Journal, vol. xxxvi, p. 208, 1888. Bull. U. S. Geol. Surv. 66, 1890.

‡ Bull. U. S. Geol. Surv. 139, p. 129, 1896.

§ Zeit. deut. Geol. Gesell, 1892, p. 824.

|| Enclaves des rockes volcaniques, Ann. Acad. Macon, vol. x, 1893, p. 17.

1

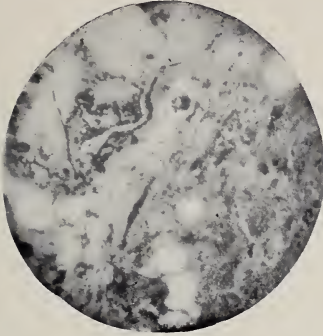

2



3

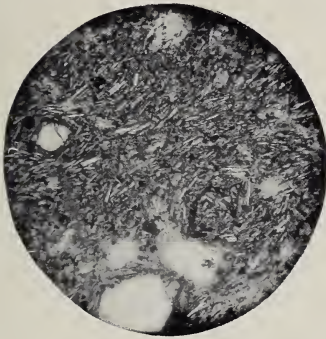

4

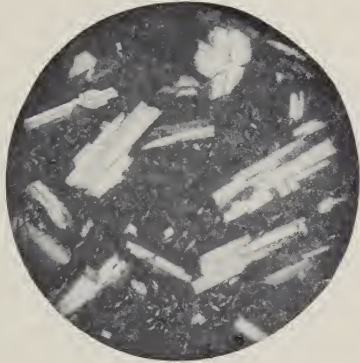

5

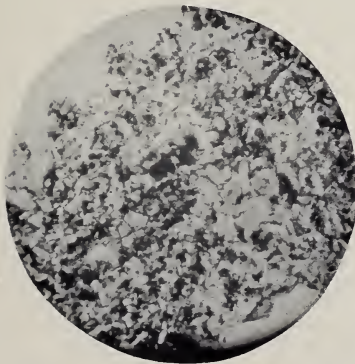

6

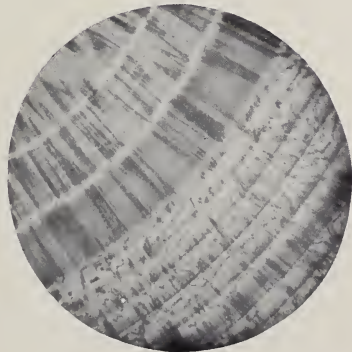



## SCIENTIFIC INTELLIGENCE.

## I. CHEMISTRY AND PHYSICS.

1. *The Gases produced by Actinium.*—It is known that solutions of radium salts give off continuously a mixture of hydrogen and oxygen from the decomposition of water, and it has been found that this detonating gas contains a small quantity of helium which is believed to be a product of the disintegration of the radium atom. DEBIERNE has recently confirmed this behavior of radium by using nearly a tenth of a gram of Curie's radium bromide and operating in a manner similar to that of Ramsay and Soddy. He has found, further, that solutions of actinium salts give off detonating gas containing helium, and that the amounts of these products apparently correspond to the amounts produced by a quantity of radium having the same activity.

For the experiments with actinium he used the whole of his most active products, and obtained the same results with a portion which had been specially purified from any possible contamination with radium by adding to it barium chloride and removing the barium. It was found, moreover, that the barium thus removed did not contain an appreciable quantity of radium. It was found also that solid actinium fluoride gave off helium. Debierne states that in addition to the large quantity of emanation with a rapid rate of decay which is given off by solid salts of actinium, there comes from it a very small quantity of an emanation of much slower change which he has identified as identical with the radium emanation; but its quantity is too small to have produced the helium found in his experiments.—*Comptes Rendus*, cxli, 383.

H. L. W.

2. *A New Heavy Solution.* — DUBOIN has prepared some liquids analogous to the well-known Thoulet's solution, one of which, at least, appears to possess decided advantages over the latter. In the place of the potassium iodide used by Thoulet, he uses sodium or lithium iodide. The alkaline iodide and mercuric iodide are alternately added to a small quantity of water until saturation takes place, the temperature being slightly raised at the end of the operation. Then the liquid is allowed to cool, and after twenty-four hours it is filtered. It was found that Thoulet's solution prepared in this way, and filtered at 22·9°, gave a specific gravity of 3·196 and an index of refraction of 1·730, while the sodium mercuric iodide solution, filtered at 24·75°, gave a density of 3·46 and an index of refraction of 1·797. The lithium solution is intermediate in its density and refraction between the two just mentioned. Analyses of the solutions showed that their compositions corresponded closely to the formulas  $K_2HgI_4$ ,  $Na_2HgI_4$  and  $Li_2HgI_4$ , and in each case the amount of water present was somewhat more than 10 per cent. A similar ammonium mercuric iodide solution was prepared, but this was less dense than Thoulet's liquid.

The sodium mercuric iodide solution is of considerable interest, as it is heavier than even methylene iodide. Although water produces in it a precipitate of mercuric iodide, it dissolves without change in alcohol and many other organic liquids.—*Comptes Rendus*, cxli, 385.

H. L. W.

3. *Hydrolysis of very Concentrated Ferric Sulphate Solutions*.—It has been observed by RECOURA that a concentrated solution of ferric sulphate made by dissolving the anhydrous salt in its own weight of water is completely decomposed when it is placed in contact with acetone for several days. The products are sulphuric acid, which dissolves in the acetone, and a basic ferric sulphate which separates in the solid form. The latter is yellowish white in color, is soluble in water, and has a composition represented by the formula  $6\text{Fe}_2(\text{SO}_4)_3 \cdot \text{Fe}_2\text{O}_3 \cdot \text{H}_2\text{O}$ . The same solid is formed without the use of acetone when a strong solution of ferric sulphate is placed in a well-stoppered flask and allowed to stand for a longer time. With solutions of the strength given above, the deposit begins to form after about twelve days and extends through the liquid in about a month. With stronger solutions the precipitate is formed more rapidly and abundantly, while with solutions slightly more dilute no basic salt separates. The deposit is formed most rapidly at  $20^\circ$ , and more slowly as the temperature is kept lower.—*Comptes Rendus*, cxl, 1685.

H. L. W.

4. *Separation of Gold from the Metals of the Platinum Group*.—JANNASCH and VON MOYER have found that gold is precipitated quantitatively by a salt of hydrazine in any kind of solution. This reagent, however, on account of its powerful reducing action does not serve to separate gold from the metals of the platinum group, although it is thus separated satisfactorily from potassium, sodium, barium, strontium, calcium, magnesium, aluminium, chromium, zinc, manganese, iron, uranium, nickel, cobalt, cadmium, mercury, lead and copper. Gold is precipitated by a hydroxylamine salt in acid solution somewhat slowly, and not below a temperature of  $80^\circ$ . Preliminary tests indicate that hydroxylamine hydrochloride is a satisfactory reagent for the separation of gold from palladium, platinum, iridium and rhodium, as well as from ruthenium and osmium.—*Berichte*, xxxviii, 2129.

H. L. W.

5. *Determination of Sugar with Fehling's Solution*.—On account of difficulties encountered in determining small quantities of sugar by Fehling's volumetric method, LAVALLE has modified this by carrying it out in the presence of an excess of caustic soda, so that the cuprous oxide produced remains in solution, and the change in color is more readily detected. The operation is as follows: In a porcelain dish of  $200\text{cc}$  capacity are placed 5 or  $10\text{cc}$  of Fehling's solution,  $30\text{cc}$  of sodium hydroxide solution (1:3), and 50 or  $60\text{cc}$  of distilled water. The liquid is then heated, and when it begins to boil the solution to be tested is gradually added. The operation is finished when the last drop causes the blue color of the Fehling's solution to disappear.—*Berichte*, xxxviii, 2170.

H. L. W.

6. *Slow Transformation Products of Radium.*—An article by Prof. E. RUTHERFORD, in the September number of the Philosophical Magazine, closes with the following summary of the products recognized in the slow transformation of radium.

“The results of the comparison of the products of radium with those contained in polonium, radio-tellurium, and radio-lead are summarized below.

Products in old Radio- lead.	}	Radium D = product in <i>new radio-lead</i> , no rays. Half transformed in 40 years.
		Radium E = gives out $\beta$ rays, separated with bismuth, and iridium. Half transformed in 6 days.
		Radium F = product in polonium and radio tellurium. Gives out only $\alpha$ rays. Half transformed in 143 days.

The family of substances produced by the disintegration of radium, together with the time for each to be half transformed, is shown diagrammatically in the figure.

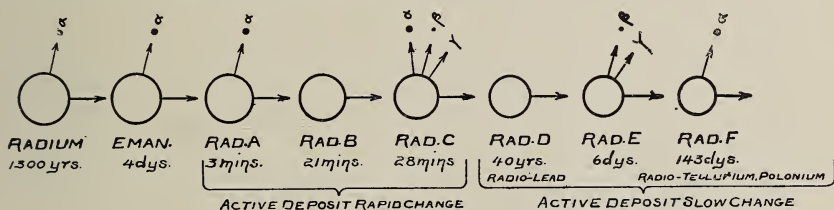

It is now fully established by the researches of Boltwood, Strutt, and McCoy that the amount of radium present in radio-active minerals always bears a constant ratio to the amount of uranium. The investigations of Boltwood, in particular, have shown a surprisingly good agreement between the content of radium and uranium for minerals obtained from various localities, which differ very widely in their content of uranium. This proportionality is a strong indication that radium is produced from uranium; and a conclusive proof of this point of view is given by the experiments of Soddy and Whetham, who find that there is a slow growth of radium in uranium which was initially freed from radium. In addition, the actual amount of radium in radio-active minerals is of the right order of magnitude to be expected from theoretical considerations, if uranium is the parent of radium.

Soddy finds that the present growth of radium from uranium is only a very small fraction of the theoretical amount. This is most simply explained by supposing that one or more products of slow period of transformation intervene between  $UrX$  and radium. The uranium-radium family and their connection with one another is summarized below.

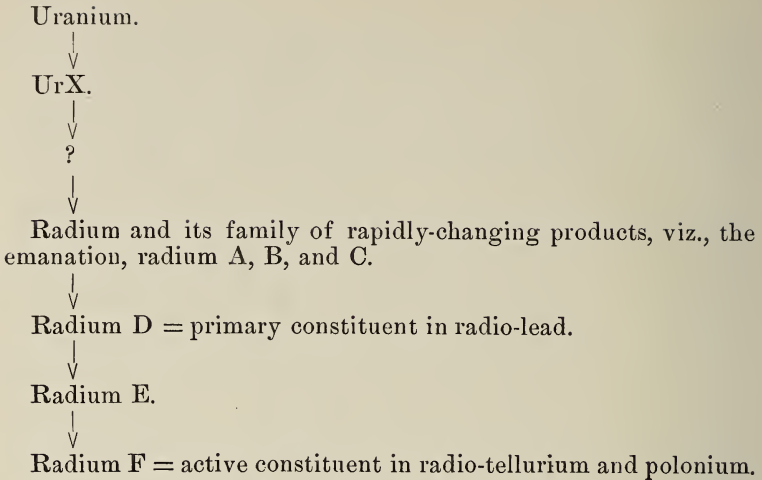

No evidence has been obtained that any further active products exist after radium F has been transformed. If the  $\alpha$  particle is a helium atom, remembering that five products are present in radium which emit  $\alpha$  particles, the atomic weight of the transformation product of radium F should be  $225 - 20$  or  $205$ . This is very close to the atomic weight of lead,  $206.7$ . The view that lead is the final or end product of the transformation of radium is supported by the fact that lead is always found in the radioactive minerals in about the amount to be theoretically expected from the content of uranium, when the quantity of helium, present in the mineral, is used to compute its probable age.\* A similar suggestion has recently been advanced by Boltwood."

## II. GEOLOGY AND MINERALOGY.

1. *Indiana, Department of Geology and Natural Resources, Twenty-ninth Annual Report*, W. S. BLATCHLEY, State Geologist, 1904. 888 pp., 34 pl.—This Twenty-ninth Report of the State Geologist of Indiana is largely devoted to the economic interests of the state, which have shown a very large increase in recent years. Thus comparing the figures for 1895 with those for 1904, although there has been a falling off in natural gas, the amount of coal produced has been more than doubled and that of petroleum increased nearly three times, while the value of the output of building stone and of clay products has also doubled. Twenty-five years since the resources of the state were almost exclusively agricultural, while in 1904 the total value of the mineral resources amounted to not less than forty million dollars. The present volume discusses very fully the clays and clay industry of the

\* A full discussion of this question was given by the writer in the Silliman Lectures, Yale University, March, 1905.



state, in which direction the state has been found to be very rich, the shales, particularly those of the Coal Measures, which were not many years since supposed to be valueless, now being turned on an extensive scale into pipes and tiles, bricks of various kinds and other products. An account is also given of the petroleum industry, and the volume closes with an illustrated chapter upon the insect galls of Indiana by Melville T. Cook.

2. *Geological Survey of Louisiana, G. D. Harris, Geologist-in-charge.*—It is announced that hereafter the biennial reports of the State Survey of Louisiana will be brought out first as Bulletins and subsequently will be bound up in part as regular volumes. Of the Report of 1905, three Bulletins have already appeared: No. 1—The Underground Waters of Louisiana; No. 2—Magnetic Survey of Louisiana; and No. 3—Tide Gauge Work in Louisiana. These may now be had gratis by addressing Dr. W. R. Dodson, Director Experiment Station, Baton Rouge, La.

3. *Geological Survey of New Jersey. Annual Report of the State Geologist, Henry B. Kummel, for the year 1904.* 317 pp., 19 plates, 18 text figures. Trenton, 1905.—This report contains a popular account of fossil fishes and their place in paleontology, by Dr. C. R. Eastman, followed by a detailed account of the fossil fishes of the Triassic as found in the Newark formation. Dr. Weller contributes papers on the faunas and corresponding formations of the Cretaceous of New Jersey. Professor F. B. Peck has a chapter on the talc deposits of Phillipsburg, N. J., and Easton, Pa., while the molding sands are treated by H. B. Kummel and S. H. Hamilton. Progress is noted in the survey of the pre-Cambrian rocks in coöperation with the United States Geological Survey, and further parts treat of well records, forest fires and mining. The work throughout the report is thorough and of high grade; it deals largely with subjects of practical value to the state.

J. B.

4. *Brief descriptions of some recently described Minerals.*—BECKELITE is a silicate of the cerium metals and calcium, described by J. Morozewicz and named after Prof. Fr. Becke of Vienna. It is found in a rock of the eleolite-syenite type, called by the author mariupolite and forming one of the petrographic elements of the Azov granite table. It occurs in coarse grains of a light yellow color, optically isotropic, also in octahedrons and dodecahedrons resembling pyrochlore. The hardness is 5 and the specific gravity about 4.15. An analysis yielded:

SiO <sub>2</sub>	ZrO <sub>2</sub> + R <sub>2</sub> O <sub>3</sub>	Mn <sub>2</sub> O <sub>3</sub>	CaO	MgO	K <sub>2</sub> O	Na <sub>2</sub> O	ign.
17.13	65.31	0.07	15.46	tr.	0.39	0.78	0.99=100.13

The rare elements forming the 65.31 of ZrO<sub>2</sub> + R<sub>2</sub>O<sub>3</sub> included the following: ZrO<sub>2</sub> 2.50, Ce<sub>2</sub>O<sub>3</sub> 28.10, La<sub>2</sub>O<sub>3</sub> 13.60, Di<sub>2</sub>O<sub>3</sub> 18.00, Y<sub>2</sub>O<sub>3</sub> + Er<sub>2</sub>O<sub>3</sub> 2.80, Al<sub>2</sub>O<sub>3</sub> 0.30, Fe<sub>2</sub>O<sub>3</sub> tr. The calculated formula is Ca<sub>3</sub>(Ce, La, Di)<sub>4</sub>Si<sub>3</sub>O<sub>15</sub>.—*Min. petr. Mitth.*, xxiv, 120, 1905.

Several new species are described by R. H. Solly, in a recent number of the Mineralogical Magazine (xiv, 72). They are

derived from the dolomite of the quarries in the Binnenthal, Switzerland. HUTCHINSONITE, named after Dr. Arthur Hutchinson, of the University of Cambridge, is a species occurring in prismatic orthorhombic crystals, with numerous terminal faces. The color is gray to grayish black, and the streak vermilion. The crystals are transparent to nearly opaque. Hardness, 1.5-2; cleavage, good, parallel to the macropinacoid. In composition it is found by G. T. Prior to be a sulpharsenite of thallium, lead, silver and copper; it contains nearly 20 per cent of the rare element thallium.

SMITHITE, named after Mr. G. F. Herbert Smith of the British Museum, occurs in monoclinic crystals, resembling flattened hexagonal prisms, with prominent basal plane. The lustre is adamantine, the color light red, and the streak vermilion. The crystals are transparent to translucent. Hardness, 1.5-2; cleavage, parallel to the orthopinacoid, perfect. The surface of the crystals changes on exposure to light from pure red to orange red. According to G. T. Prior, the composition is expressed by the formula  $AgAsS_2$ .

TRECHMANNITE, after Dr. C. O. Trechmann, occurs very sparingly in minute rhombohedral crystals resembling the two species hutchinsonite and smithite in color, streak and hardness. The crystals showed portions of hexagonal prisms, with small pyramidal and rhombohedral faces. Cleavage was observed perpendicular to the prism. The composition is as yet undetermined.

MARRITE, named after Dr. John Edward Marr of Cambridge, occurs in highly modified monoclinic crystals, usually doubly terminated. The color is lead- to steel-gray, the surface showing iridescent tarnish; the luster is metallic, brilliant. The hardness is 3 and the fracture conchoidal; no cleavage was observed. Only a single specimen had been found at the time the description was published; this showed some fifteen small crystals implanted upon the dolomite, hence though the crystallographic data are complete the composition is yet to be determined.

LENGENBACHITE, named after the Lengenbach, a tributary stream in the Binnenthal, occurs in bladed crystals often very thin and sometimes curled up like paper. They show a highly perfect cleavage and splendid luster; the crystals are apparently twinned and are inferred to belong to the triclinic system. The plates are flexible and somewhat malleable but not elastic. The color is steel-gray, often with iridescent tarnish, the luster metallic; the specific gravity is 5.80. In composition it is essentially a sulpharsenite of lead with small amounts of antimony, silver and copper, as determined by A. Hutchinson.

BOWMANITE, named after H. L. Bowman of the University of Oxford, occurs in rhombohedral crystals with basic cleavage and having the form of six-sided plates, often grouped in rosettes; the crystals show a pseudo-symmetry in the basal sections. The color is honey-yellow, the luster brilliant vitreous to resinous. The hardness is 4.5, the specific gravity 3.2. According to Bowman it is essentially a phosphate of lime and alumina with small amounts of iron, water and possibly magnesia.

# COLLEGES NEED :

The Leuckart Zoological Wall-Charts.

The Zittel Palæontological Wall Charts  
and Keller Reconstructions of Ancient Life.

Our Improved Mineral and Rock Trimmer.

Common Minerals by the Pound.

Biological Laboratory Supplies.

Our Unsurpassed Special Dissections.

The Shaler-Davis-Harris Series of Physiographic Models and  
Photographs.

Our Geological Models and Relief Maps.

Beecher Restorations of Trilobite and Stylonurus  
and Models of Typical Brachiopods.

Clarke Restorations of Eurypterus and Hughmilleria.

Casts of Famous Inscriptions—Rosetta Stone, Black Obelisk,  
Deluge Tablets, etc.

Our Genetic Collection of Rocks.

Our Collection of Phenomenal Geology.

Penfield Goniometers, for laboratory and field use.

Our Regular College Collections of Fossils, Minerals, Rocks, and  
Invertebrate Animals.

---

*Send for catalogues or circulars of some of these.*

THEY WILL DOUBLE YOUR TEACHING EFFICIENCY.

---

**Ward's Natural Science Establishment,**

76-104 COLLEGE AVENUE, ROCHESTER, N. Y.

## CONTENTS.

	Page
ART. XXVIII.—Ultimate Disintegration Products of the Radio-active Elements ; by B. B. BOLTWOOD .....	253
XXIX.—Use of the Rotating Cathode for the Estimation of Cadmium taken as the Sulphate ; by C. P. FLORA ..	268
XXX.—Crystallization of Luzonite ; and other Crystallographic Studies ; by A. J. MOSES .....	277
XXXI.—Determining of the Optical Character of Birefracting Minerals ; by F. E. WRIGHT .....	285
XXXII.—Groups of Efficient Nuclei in Dust-Free Air ; by C. BARUS .....	297
XXXIII.—Studies in the Cyperaceæ ; by T. HOLM .....	301
XXXIV.—Preliminary Note on some Overthrust Faults in Central New York ; by P. F. SCHNEIDER .....	308
XXXV.—Petrography of the Tucson Mountains, Pima Co., Arizona ; by F. N. GUILD .....	313

### SCIENTIFIC INTELLIGENCE.

*Chemistry and Physics*—Gases produced by Actinium, DEBIERNE : New Heavy Solution, DUBOIN, 319.—Hydrolysis of very Concentrated Ferric Sulphate Solutions, RECOURA : Separation of Gold from the Metals of the Platinum Group, JANNASCH and VON MOYER : Determination of Sugar with Fehling's Solution, LAVALLE, 320.—Slow Transformation Products of Radium, E. RUTHERFORD, 321.

*Geology and Mineralogy*—Indiana, Department of Geology and Natural Resources, Twenty-ninth Annual Report, W. S. BLATCHLEY, 322.—Geological Survey of Louisiana : Geological Survey of New Jersey : Brief descriptions of some recently described Minerals, 323.

### TEN-VOLUME INDEX.

An *extra number*, containing a full Index to volumes XI to XX of the Fourth Series, will be ready in December. Sent only to those who specially order it. Price one dollar.

Established by BENJAMIN SILLIMAN in 1818.

THE  
AMERICAN  
JOURNAL OF SCIENCE.

EDITOR: EDWARD S. DANA.

ASSOCIATE EDITORS

PROFESSORS GEORGE L. GOODALE, JOHN TROWBRIDGE,  
W. G. FARLOW AND WM. M. DAVIS, OF CAMBRIDGE,

PROFESSORS ADDISON E. VERRILL, HORACE L. WELLS,  
L. V. PIRSSON AND H. E. GREGORY, OF NEW HAVEN,

PROFESSOR GEORGE F. BARKER, OF PHILADELPHIA,  
PROFESSOR HENRY S. WILLIAMS, OF ITHACA,  
PROFESSOR JOSEPH S. AMES, OF BALTIMORE,  
MR. J. S. DILLER, OF WASHINGTON.

FOURTH SERIES

VOL. XX—[WHOLE NUMBER, CLXX.]

No. 119.—NOVEMBER, 1905.

WITH PLATES X, XI.

NEW HAVEN, CONNECTICUT.

1905

THE TUTTLE, MOREHOUSE & TAYLOR CO., PRINTERS, 123 TEMPLE STREET.

Published monthly. Six dollars per year, in advance. \$6.40 to countries in the Postal Union. Remittances should be made either by money orders, registered letters, or bank checks (preferably on New York banks).

# RARE MINERALS IN TON LOTS

Correspondence solicited with miners or consumers of the ores of

**Molybdenum**

**Tantalum**

**Thorium**

**Titanium**

**Tungsten**

**Uranium**

**Vanadium**

**Yttrium**

**Zirconium**

and other rare metals. Offers from producers should be accompanied by samples.

---

## SYSTEMATIC COLLECTIONS OF TYPICAL SPECIMENS

In sets of twenty-five up to fifteen hundred specimens. Prices \$5.00 upwards per set, the average price for students' specimens being about twenty cents. We have supplied the leading institutions for thirty years, having lately completed a single order for over 60,000 specimens. Our material is the accepted standard both as to correct labeling and high quality.

**Free Collection Catalog**, containing lists and illustrations of General Mineral Collections, Series of Ores for Prospectors, Sets of Crystals, Series illustrating Hardness and other Physical Characters of Minerals, with Price List of Laboratory Material and Individual Specimens.

---

## FOOTE MINERAL CO.,

Established 1876, by Dr. A. E. Foote.

**W. M. FOOTE, Manager.**

DEALERS IN

**MINERAL SPECIMENS AND COMMERCIAL RARE MINERALS,**

1317 Arch Street, Philadelphia.



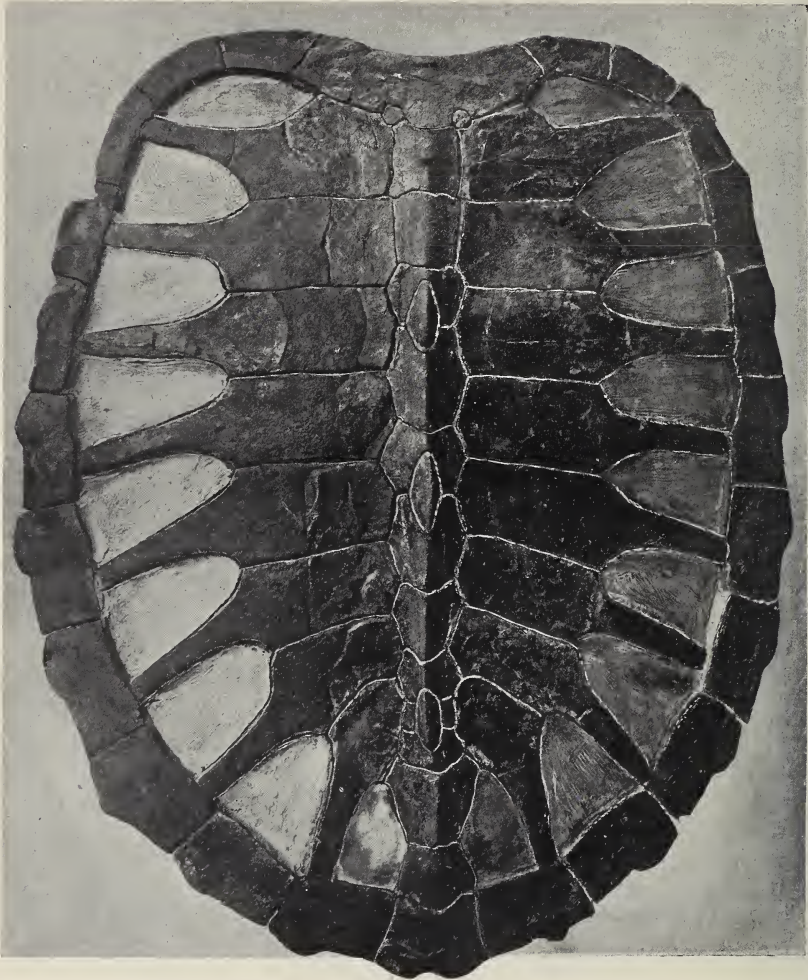

Carapace of *Toxochelys Bauri* Wieland sp. nov. from the Niobrara Cretaceous of Gove County, Kansas, as partly restored and mounted in the Yale Museum.—Actual length about 53<sup>cm</sup>.



THE

# AMERICAN JOURNAL OF SCIENCE

[FOURTH SERIES.]

---

ART. XXXVI.—*A New Niobrara Toxochelys*;\* by G. R. WIELAND. (With Plate X.)

NONE of the numerous marine, or semi-marine turtles from the Kansas chalk or Niobrara Cretaceous have proven of greater interest than the forms included within the genus *Toxochelys*. For this wholly extinct American group unites carapacial and plastral characters of the *Lytolomas* of the Upper Cretaceous of New Jersey with *Chelydra*-like cranial features, and is well represented by a considerable number of specific forms and variations presenting fairly clear evidence that we have here to deal with a line which independently acquired the modifications of limb structure suiting at least some of its members to a marine habitat.

Moreover it is very significant that discrete epi-neural ossicles somewhat similar to those the writer supposed might be present in *Archelon* are borne serially either on the neuralia, or over the neural junctions in an order suggesting that they have an ancient history, possibly analogous to the ossicles of somewhat similar form so characteristic of the Crocodylidae and in part the Chelydridae. These ossicles as noted further on were first observed in *Toxochelys (serrifer) stenoporis* by Case (2) and later more fully described and commented on by Hay (6, 7, 8). The character of the entire series is, however, now determined for the first time. The idea that such ossi-

\* The writer's previous contributions, mainly on the marine turtles, are as follows:—

This Journal, vol. ii, Dec., 1896, pp. 399-412, pl. VI. American Naturalist (p. 446), 1897. This Journal, vol. v, Jan., 1898, pp. 15-20, pl. II; vol. ix, Apr., 1900, pp. 237-251, pl. II; vol. ix, June, 1900, pp. 413-424; vol. xiv, Aug., 1902, pp. 95-108; vol. xv, March, 1903, pp. 211-216; vol. xvii, Feb., 1904, pp. 112-132, pls. I-IX; vol. xviii, Sept., 1904, pp. 183-196, pls. V-VIII.—(In Press,—Protostega; Memoirs, Carnegie Museum of Pittsburgh; Plastron of Protosteginae.)

AM. JOUR. SCI.—FOURTH SERIES, VOL. XX, NO. 119.—NOVEMBER, 1905.

cles really represent a disappearing series of dermal elements is further strengthened by the writer's observation that interpolated ossicles also occur in the marginal series of occasional specimens of *Lytoloma angusta*, as will be further considered below.

Despite the frequent occurrence of Toxochelyds in the Niobrara, until now no complete carapace has been described. It is, therefore, of timely interest that a specimen collected by Mr. Charles H. Sternberg in Gove County, Kansas, and very recently acquired by the Yale Museum, includes a carapace and plastron sufficiently complete to determine accurately all the details of shell structure and form. The original locality, according to Mr. Sternberg, is in a ravine about three miles north of Monument Rocks, and about four miles east of the western Gove County line. This fossil is numbered 2823 in the Yale Museum accession list, and on the basis of the analysis given below is referred to the new species *Toxochelys Bauri*, in honor of that distinguished student of the Testudinata the late lamented Professor Georg Baur. As shown on Plate X, *T. Bauri*, represents one of the most ornate of all extinct Testudinate species. The type consists in the following elements:—

The nuchal and eight closely articulated neuralia with the ninth median or post-neural element bipartite, and followed by an antero-pygial and the pygal marginal (the postero-pygial being the only median element absent); three epi-neural ossicles respectively seated on the 3d and 4th, the 5th and 6th, and the 8th–10th members of the neural series; the 1st–3d, and the 8th–11th right marginals; the 4th–6th, 8th and 10th left marginals; most of the pleuralia; also the right hyo- and hypoplastron nearly complete, and various fragments of vertebræ with several centra and arches. Of the right pleuralia the first and seventh are complete, and the third, fourth and sixth only lack rib-tips, while the expanded plates of all the right pleurals but the distal portion of the fifth, are fortunately present. On the left side the pleurals are not so complete, only the proximal ends having been recovered, with the exception of the third, which only lacks a middle portion of the plate. Cf. figure 6.

The hyo- and hypoplastron lack their interior digitations, but fortunately permit an approximate restoration from what is known of the plastron of several other species (cf. figure 7). The fragmentary or not directly determinable skeletal parts include two dorsal centra, 4<sup>cm</sup> in length, and several caudal centra, with a few portions of cervicals.

With the exception of some of the middle and anterior marginals, which are curiously crushed from very different

angles, the various elements of the present in reality exceptionally fine fossil do not appear to have been much displaced in their original chalk matrix. This had been removed, however, and aside from the neurals, which remained for the greater part solidly articulated, any clues to form and organization afforded by position in the matrix had been thus destroyed before the specimen reached the Yale Museum.

Despite this crushing and dissociation of parts, as the result of a careful joint examination by the Museum preparateur, Mr. Gibb, and the writer, it has nevertheless proven possible for the former to make a very handsome and successful mounting of the fine carapace with the considerably restored plastron in its approximately natural position, as illustrated on Plate X, and figures 1-3, and 6, 7. In fact it is owing to the presence of the nearly complete hyo- and hypoplastron that we are enabled to determine the true width of the carapace, which is indicated in the corrected drawing (figure 1) based in part on the measurement thus obtained. The specimen itself is mounted more nearly as removed from the chalk matrix, the width being somewhat exaggerated by compression. For it was at once decided that it would be far better in mounting the specimen to adhere nearly to the form that had resulted from crushing in the matrix, rather than to distort the junctions of the several elements in an effort to reach the elongate form *Toxochelys Bauri* really had. The restoration is accordingly, although at first sight indicating a considerable length of shell, not nearly so narrow and relatively long as originally in life,—an interesting fact because this is almost the only marine form with a carapace suggestive of the great length seen in *Dermochelys*.

#### *Description of Parts.*

As the main features of the anatomy of the carapace appear in sufficient detail in the summary of characters and measurements given below, taken in conjunction with the accompanying figures and plates, we may pass on to a discussion of the special or unique features of interest, namely the *nuchal*, the *epi-neural spines*, and the *pygal region*.

*Nuchal*.—The Trionychid-like fontanelles at the junction of the nuchal, first neural and pleurals (figure 1, *f*), are circular to slightly elliptical, and 1<sup>cm</sup> in diameter. Such have not been hitherto observed to occur outside the Trionychids, and with the general form of the nuchal suggest a certain connection with original lines less distant from the Trionychid stocks than are the Cheloninæ. Elsewhere the writer has suggested that the Nuchal and Epiplastra of *Dermochelys*, *Protostega*, and the *Jurassic* Thalassenyds may go to indicate a yet

closer relationship to stocks ancestral to the Trionychidæ, and that there are many most suggestive indications that indepen-

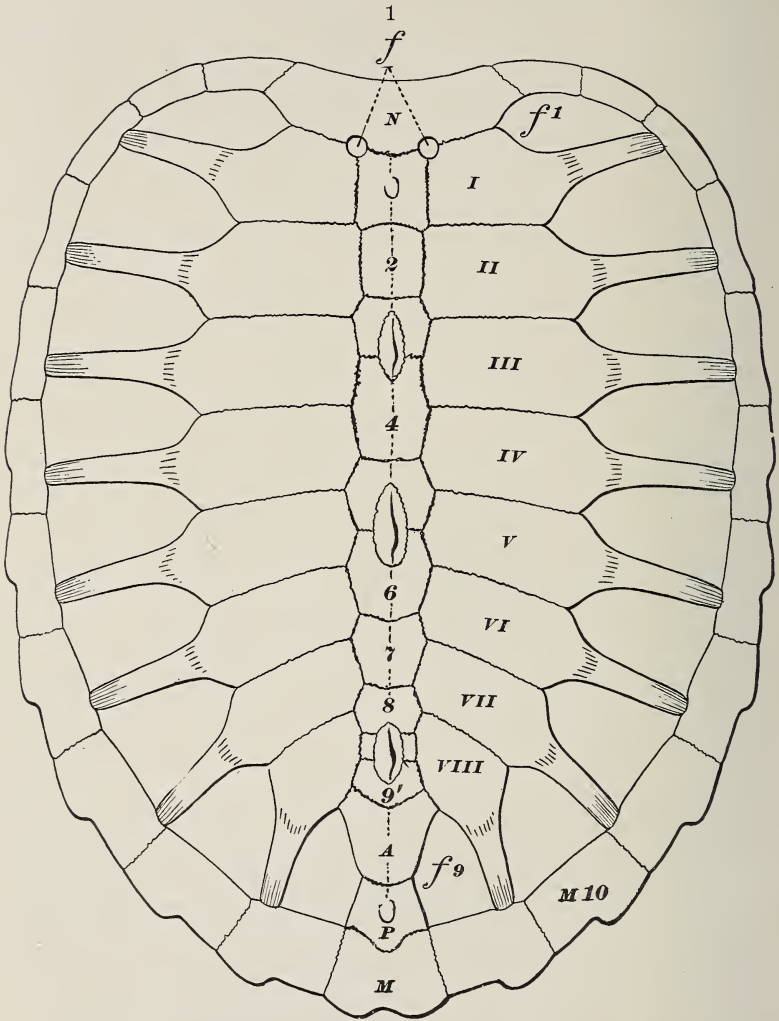

FIGURE 1.—Carapace of *Toxochelys Bauri* Wieland,  $\times \frac{1}{4}$  nearly. (Drawn from type.) *N*, Nuchal; 2, 4, 6, 8, Neuralia; 9', posterior segment of the 9th or post-neural element of the median series; *A*, Antero-pygal; *P*, Postero-pygal; *M*, Marginalo-pygal; I–VIII, the Pleuralia; *M10*, 10th (rib-free) Marginal; *f*, the post-nuchal foramina; *f*<sup>1</sup>, *f*<sup>8</sup>, 1st and 8th pleuro-marginal fontanelles. The three Epi-neurals are not lettered.

dent marine races of Testudinates, of which at least a half dozen may be enumerated, have been repeatedly developed ever since the Jurassic.

It is also of much interest that while in forms like *Osteopygis* a nether nuchal process is wholly absent, there is in the present turtle a mere, although distinct beginning of such a

2

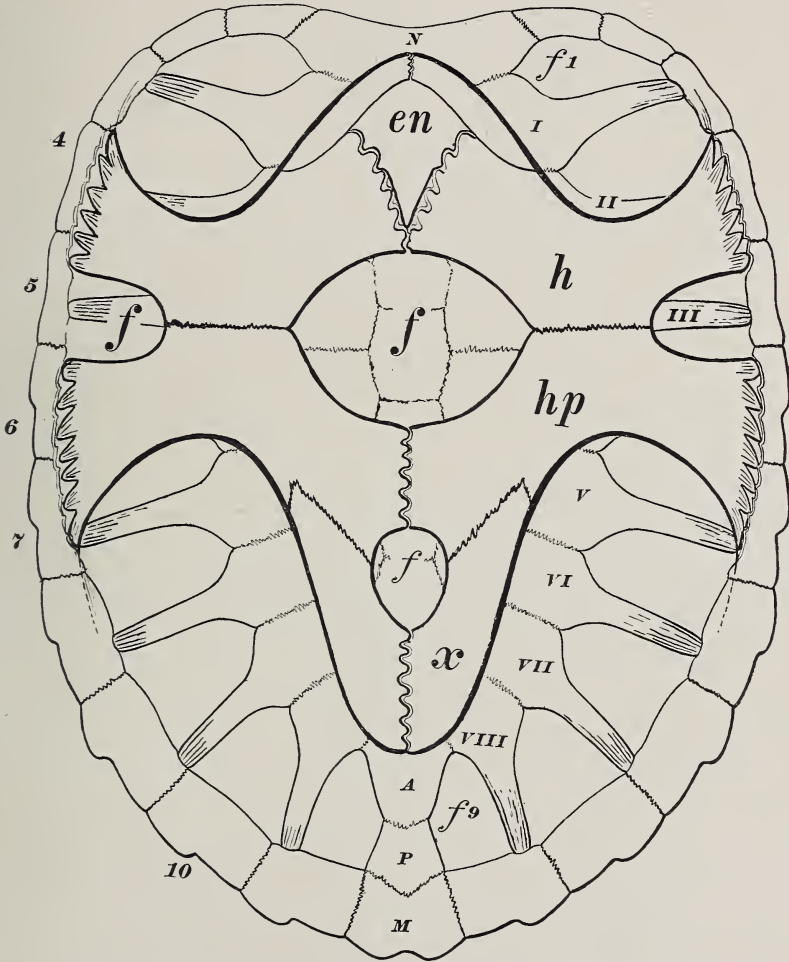

FIGURE 2.—Plastral view of *Toxochelys Bauri* Wieland,  $\times \frac{1}{4}$  nearly. (Drawn from type).—*en*, Entoplastron; *h*, Hyoplastron; *hp*, Hypoplastron; *x*, Xiphiplastron; *f*, *f*, *f*, the median and the lateral hyo-hypoplastral, and the hypo-xiphiplastral foramina; 4-7, the plastron-supporting marginalia. Other letters as in figure 1.

process, and in *Toxochelys latiremis* a much larger projection for actual cervical articulation. This process thus appears to have arisen in different groups rather than to have been com-

monly present in Cretaceous turtles, and may now be considered to have been definitely traced to its origin in at least one genus.

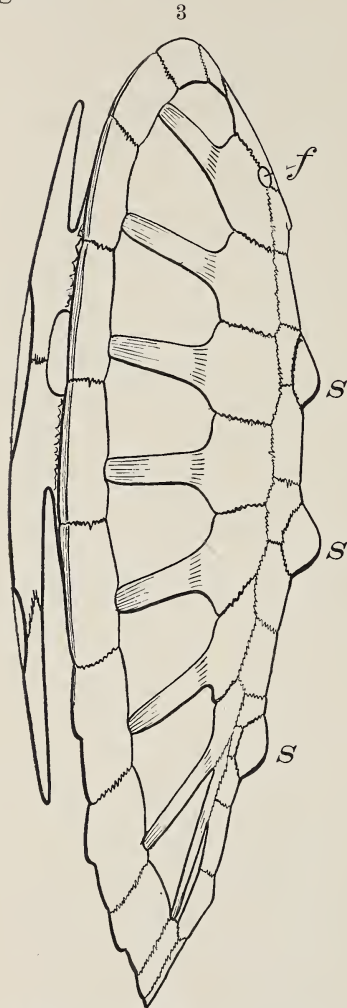

FIGURE 3.—Lateral view of the Carapace of *Toxochelys Bauri* Wieland,  $\times \frac{1}{4}$  nearly. Drawn from the type. s, s, s, the three Epi-neural spines supported respectively by the 3d and 4th, the 5th and 6th neurals, and the 8th neural and the post-neural elements; f, the post-nuchal foramina.

*Epi-neural Spines*—The series of epi-neural spines taken in conjunction with the strongly carinate neurals, and the keeled marginals, give to the present fossil carapace a most ornate form. See figures 1 and 3.

The earliest suggestion of the possible presence of epi-neural elements in the Testudinata was made by the writer in his original description of the Fort Pierre Cretaceous turtle *Arche-lon* given in this Journal for Dec., 1896. It appears on page 400 of that number as follows: "One of the chief features of the carapace is the arching into a heavy dorsal ridge, beginning just back of the region of the first dorsal vertebra, and from thence continuous, except in the sacral region. It marks the position of the neural spines and is very distinctly grooved from anteriorly to the region of the eighth dorsal vertebra. Immediately over the neural spines this groove inclines to widen and send out asteriations. In life these grooves were no doubt filled with horny material, and the animal may have borne a dorsal row of spines."

Two years later the spines of *Toxochelys* were first observed by Case,\* and have been since more fully described and commented on by Hay, who would see in them the remnants of a former dermal series, probably once common to all turtles, and going far to explain the homol-

\* Kansas Univ. Geol. Survey, vol. iv, p. 382 (1898).

ogy of the osteodermal mosaic of *Dermochelys* (6, 7). The present is, however, the first time that the entire series of ossicles and their relation to the successive neurals has been determined. As may be judged from reference to the several figures, the system of ossicles may really be a much changed and disappearing one. The first neural bears a small but very distinct completely fused boss near its middle, and then forms the beginning of the dorsal carina. The third neural which is rather short, and the fourth which is abnormally long, support a large epi-neural spine. This occupies all the median posterior three-fourths of the length of the third and the anterior fourth of the length of the fourth neurals, and is doubtless the second member of the original epi-neural series. The second free epi-neural [or third of the original series] is the largest, and is equally borne by the fifth and sixth neurals. The third free epi-neural [or fourth of the hypothetical primitive series] rests over the ninth member of the neuralia, so as to project slightly forward onto the eighth and well backward over all the anterior half of the post-neural tenth. This latter epi-neural is the smallest of the three free epi-neurals.

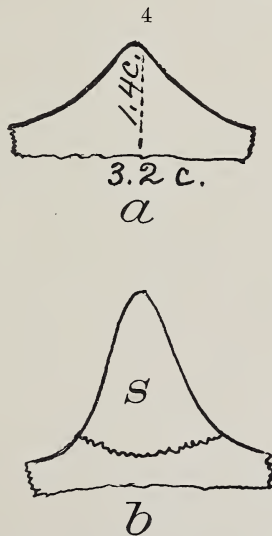

FIGURE 4.—*Toxochelys Bauri* type,  $\times 1/1$ . *a*, Vertical transverse section through the second neural showing the average elevation and outline of the median neural carina. *b*, Vertical transverse section through anterior end of the 6th neural, and the epi-neural spine (*s*) borne on this and the 5th neurals.

Whether a fifth member of the epi-neural series was borne by the postero-pygal, which would afford the symmetrical position, is of course conjectural in the absence of this latter member of the median series.

Whether or not the keels of the marginalia mark the fusion of a lateral series of elements, corresponding to the epi-neurals, is likewise only conjectural, although it appears that some light may be shed on the subject by *Proganochelys*. There is however some uncertainty as to the number of marginals and true significance of the peculiar marginal fringe of spines in this singularly interesting turtle as so carefully studied by Fraas (4) from material recovered under conditions unfavorable to the exact preservation of structural details. But it is also a most interesting and suggestive fact that small ossicles are irregularly interpolated between the lateral marginals of the Cretaceous *Lytoloma*, as small triangular elements about 1.5<sup>mm</sup> on each side. Such are shown at E, E, E in the accompanying figure 5. As these epi-marginal ossicles are not equally present on both the right and left marginals even in the same individual and certainly not always present in all specimens of *Lytoloma angusta*, they would at first sight appear to be of much less significance, taken by themselves, than are the epi-neurals of *Toxochelys*. Nevertheless it would now seem that they do represent a disappearing series that may once have invested the entire margin of the carapace. If so, they form one of the most impressive examples of the very last vestiges of a vanishing series.

The truth of this hypothesis yet remains to be mainly determined by fossil evidence, which we may hope ere long to discover, if correct. At any rate it is extremely interesting and suggestive to find further traces of an additional osteodermal series in *Lytoloma*, whatever may be the homology to that of *Dermochelys*.

What the characteristic number of elements in this system as developed in pre-Cretaceous testudines was, no one has yet attempted to suggest. Nor is it possible to reach a safe conclusion in the absence of further paleontologic evidence. It would appear however that the series was once at least as complex as is the horn-shield and the bony plate series, and that it had some form of alternate or imbricate relationship to both these latter systems. Also, if the osteodermal mosaic of *Dermochelys* arose from such an additional dermal series, such origin must therefore have been in part by a subdivision process such as was suggested to Baur by the abnormal breaking up into smaller ossicles along the edges of the pleurals observed by him in *Eretmochelys*. Such a subdivision would of course follow the lines of the original system, and could thus very well produce the carapacial carina seen in *Dermochelys*.

It should be especially noted in this connection that such an hypothesis for the more primitive origin of the osteodermal mosaic does not necessarily imply a more ancient origin for



*Dermochelys* than for the Cheloniidæ, and that its correctness would not necessarily leave *Dermochelys* the most primitive of turtles, but rather the most specialized, as hitherto held by Baur, Dollo, and the writer. As stated, only new fossil evidence can settle the very interesting questions that here arise.

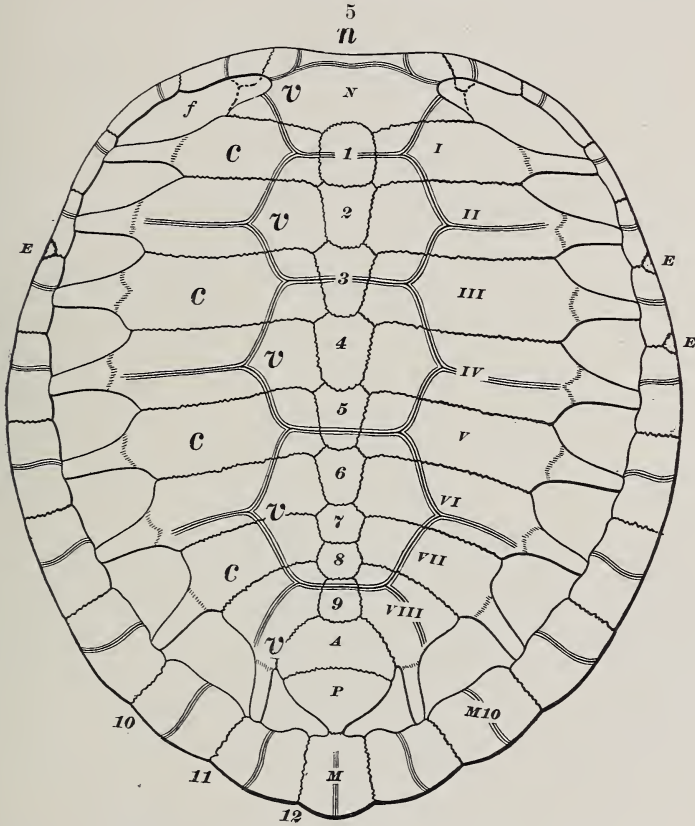

FIGURE 5.—Carapace of *Lytoloma angusta* from the Upper Cretaceous Greensand of Barnsboro, Gloucester Co., New Jersey. *E, E, E*, Epi-marginals respectively borne by the right 4th and 5th, 5th and 6th, and the left 4th and 5th marginalia. (Enough marginals are present in the original specimen—No. 625 of the Yale Collection—to determine that no further epi-marginals accompanied these three, unless such were borne anteriorly to the 4th marginals.) Epi-marginals are not always present in *L. angusta*.

*The pygal region.*—The neural series of *Toxochelys Bauri*, excluding of course the epi-neural ossicles, agrees with that of *Hardella thurgi* (1) in having ten elements, in the neural row,—in reality an interpolated element between the normal or

common eighth and ninth elements, or better a division of the ninth or post-neural region of the median series. Unlike *Hardella*, however, the pygal is not single, the post-neural region being divided into an antero- and postero-pygal, as in *Osteopygis*, and in the Cheloninæ. The existence and outlines of the postero-pygal are indicated by the conformation of the pleuralia and posterior marginals, together with the posterior suture of the antero-pygal and the anterior suture of the pygal marginal, which are quite unlike. From these sutural borders it is also quite evident that the heavy median keel which evenly traverses all the length of the antero-pygal, finally ran out on the postero-pygal, where it no doubt ended as a distinct boss like that of the first neural, which would perforce represent a fused fifth member of the median or epi-neural ossicular system. The pygal marginal, in correspondence with the strong keels of the marginals, is ornately double-keeled. The organization of this region has not hitherto been determined in any species of *Toxochelys*. Both Case (2) and Hay (6) have figured the posterior half of the carapace of *T. (serrifer) stenoporus* type, but without determining the sutures, whether because not indicated or because of difficulty of interpretation not being stated by either. A distinct difference from the present specimen is, however, obviously present in the postero-pygal region.

*Synopsis of the Characters of Toxochelys Bauri* (type).

*Carapace*.—Elliptical to elongate in outline with large and persistent pleuro-marginal fontanelles; composed of 52 bony plates and 3 additional epi-neural spinose ossicles; numerical arrangement of parts combining the general alignment and form seen in the Chelonine *Lytoloma angusta* with the post-neural arrangement of the existing *Hardella thurgi*. Surface finely granulate to smooth, and horn-shield sulci not apparent, save for notches formed by the posterior border of the marginal keels. (A distinctly leathery hide is not, however, supposed to be present.) Marginals, 11 pairs, rather narrow anteriorly, increasing very slowly in breadth to the 11th, which is still nearly twice as long as broad, outer borders all the way to the pygal marginal more and more sharply keeled anterior to the indistinct to absent horn-shield sulci, upper and nether surfaces of nearly equal area, supported by rib-ends only with the pits of the plastral digits small to indistinct and extending from the 3d to about the middle of the 7th; rib-pits small, with the 10th marginal ribless, and the 11th supporting the 9th rib anteriorly as in *Chelone* and *Lytoloma*.

Nuchal large and very broad, uniting by straight sutures with the 1st neural and 1st pleurals, between which are formed

posteriorly two small oval fenestrae as in the Trionychids; with a minute (incipient) nether articular projection but no costiform processes. Neuralia 8 with the post-neural bipar-

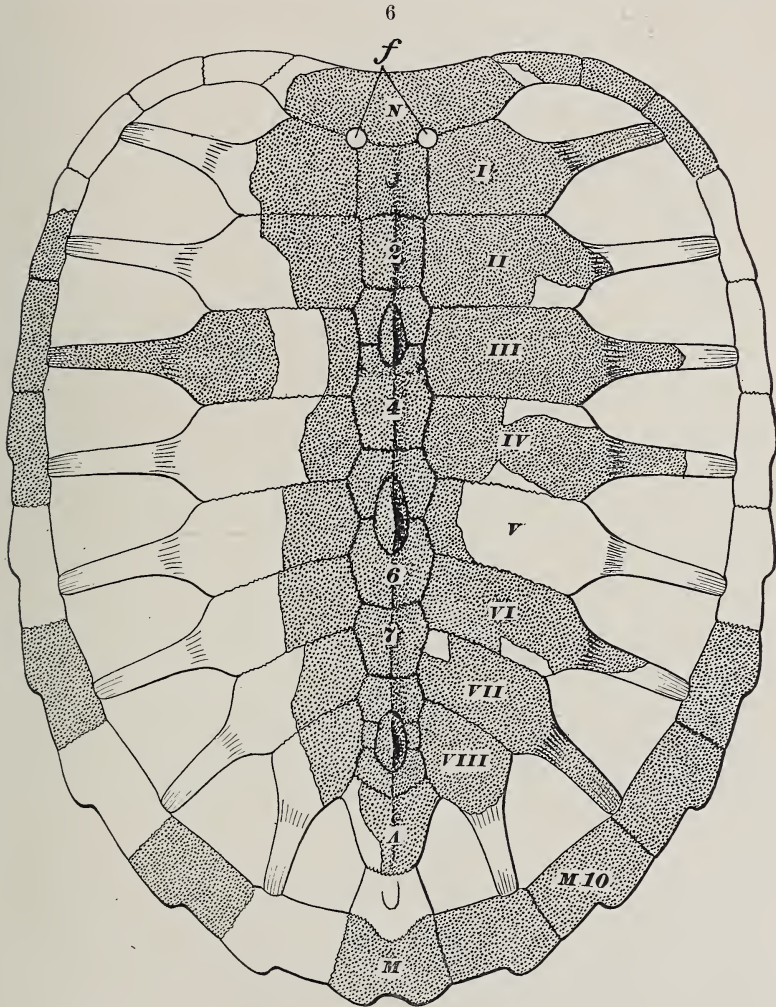

FIGURE 6.—*Toxochelys Bauri* (type). A supplementary figure to Plate X, showing by stippled surfaces the parts of the original carapace actually recovered. (Lettering as in figure 1.)

tite, oblong to hexagonal, prominently carinate and supporting the three large epi-neural spinose ossicles. Antero- and postero-pygals nearly as in *Lytoloma*. Pleuralia more reduced than in either *Chelone* or *Lytoloma*.

*Plastron*.—Of the same Chelydroid form seen in *Osteopygis* and *Lytoloma*.

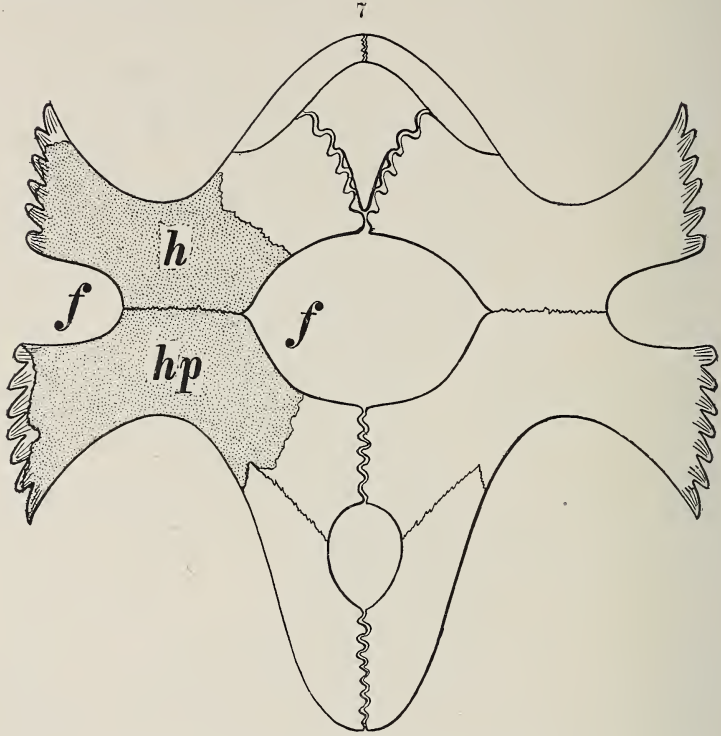

FIGURE 7.—*Toxochelys Bauri* (type). Restoration of the plastron.  $\times \frac{1}{4}$ .—The stippled surface shows the portions of the hyoplastron (*h*) and the hypoplastron (*hp*) actually recovered.—(The epiplastron and entoplastron is only known in *T. latiremis*, cf. figure 8, and the xiphiplastron in *T. stenoporus*.)

#### *Specific Relationships.*

The specific identity of the *Toxochelys* described in the foregoing pages with any of the known species of the genus cannot be affirmed, as appears from the following analysis.—Five species have been assigned to the Niobraran genus *Toxochelys* as first established by Cope in 1873, namely: *T. latiremis*, the generic type; *T. serrifer*, Cope, 1875; *T. brachyrhinus*, Case, 1898; and *T. procaræ* and *T. stenoporus*, as proposed in a recent revision of the genus by Hay (8).

With *T. latiremis* as close a comparison as desirable is not yet afforded, since but few of the elements of the carapace and plastron of this form are known. It appears, however, that the nuchal was of markedly different proportions from those

of the present *T. Bauri*, as may be noted on comparison with a nuchal figured by Case.\*

Nor is there specific agreement with the nuchal of the Yale specimen I referred to, *T. latiremis*, when describing the accompanying flipper (10). This nuchal is here shown in figure 8 for the sake of more convenient reference.

8

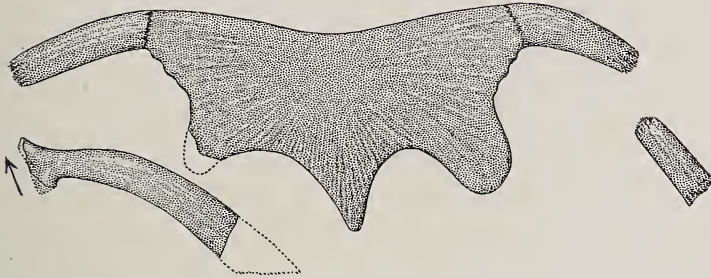

FIGURE 8.—*Toxochelys latiremis*, from the Niobrara Cretaceous, Gove County, Kansas. (Yale accession list 2419.)  $\times$  about  $\frac{1}{3}$ .

Nuchal with the attached first marginals of both sides and the proximal half of the right second marginal, together with the accompanying epiplastron.—This nuchal bears far back nearly in line with the front border of the large curved posterior notches a large and prominent nether process for cervical articulation.

Although true that the general form varies in turn from that just noted as figured by Case, the differences are more easily reconciled within specific limits. The simple fact is that in no previously described specimen of *Toxochelys*, and in no other semi-marine, or marine member of the Cheloniidæ, do we observe Trionychid-like foramina between the nuchal and first neural and pleurals. I may add that from recent measurements given by Hay it appears that amongst the several *Toxochelys* *T. brachyrhinus* is next related to *T. latiremis*; and there is a question in my mind if the former is a distinct species, the differences in cranial proportion from *T. latiremis* being so slight as to be of very doubtful significance in specimens so invariably crushed at more or less varying angles as are the Niobrara fossils.

With the skull fragments and crushed [9th] left marginal of *T. serrifer* as recently figured for the first time by Hay (8), I am unable to identify the present handsome specimen. As the horn-shields of *T. serrifer* formed a very deep marginal notch leading into a pronounced sulcus (as indicated by Hay), there appear to be distinct differences. It is, of course, one of the difficulties of vertebrate paleontologists that species based

\* University Geol. Survey of Kansas, pl. lxxxii, figure 3.

on such meager skeletal parts accumulate in the course of time; but surely we are permitted little diffidence in applying the laws of priority and nomenclature now in vogue to a handsome and reasonably complete fossil like that discussed in the present paper. Perhaps the day is not distant when fragments will be merely noted within generic limits, and then numbered and laid aside for a certain number of years before being arbitrarily dignified as the types of new forms. Assuredly such a method would simplify the study of extinct faunæ. The extreme difficulty of reaching accurate specific identifications after most painstaking comparisons and study of descriptions primarily based on fragmentary material, has been especially brought home to the writer in his consideration of the Upper Cretaceous Turtles of New Jersey, and he has great sympathy with Professor Marsh's oft repeated contention that the types of extinct vertebrates ought to be mainly founded on fairly complete forms.

With the isolated and imperfect skull of rather large and robust form named *T. procaæ* by Hay, as with that of *T. brachyrhinus*, no comparisons are afforded by the material thus far obtained.

From *T. (serrifer) stenoporus*, finally, *T. Bauri* differs distinctly, as shown by comparison with the posterior half of the carapace figured by Case.\* From that and other specimens of *T. (serrifer) stenoporus* the present fossil differs in being of a larger type with relatively heavier marginals and larger pleural plates; also in the much more pronounced sutural union of the postero- and marginalo-pygals, which is reduced to peg-like junction in *T. (serrifer) stenoporus*.

#### *Systematic Position of the Genus Toxochelys.*

Because of the carapacial organization with much reduced pleurals and marginals, as well as certain plastral characters, all suggesting primitive relationships to the Cheloniidæ, it was first suggested by the writer on his discovery of the organization of the front leg of *Toxochelys latiremis*, that the Toxochelyds do not justly constitute a separate family of turtles, as proposed by Cope and held by Hay, but are better classified as a sub-family of the Cheloniidæ, the Toxochelydinæ. Recently Hay, while accepting the principle that the limbs do furnish "a test of the correctness of this disposition of the genus," interprets the evidence differently (7). He now reaches the conclusion that Wieland misinterpreted the limbs of *T. latiremis* (10), and that these, as in the Trionychid *Amyda spinifera*, were merely long fingered and webbed,

\* Kansas Univ. Geol. Sur., vol. iv, plate lxxxiii.

and not markedly modified for marine life, so that *Toxochelys* "did not navigate the open seas."

In support of his contentions Dr. Hay uses a percentual method of comparison in which the humerus is conveniently and arbitrarily considered the unit in terms of which the length of the digits is expressed. This very effective means of comparison was first used by the writer in the case of forms in other ways related, and is, within limits, unquestionably useful in a diagrammatic sense. But Dr. Hay now mistakenly employs it in a far wider application than originally contemplated, when he reaches direct conclusions as to the front limb of *Toxochelys* by comparison with the Trionychid *Amyda spinifera*, thus:—

	ARM.			FINGERS.				
	Humerus.	Radius.	Ulna.	1st.	2d.	3d.	4th.	5th.
<i>Amyda</i>	100	53	51	69	90	98	116	98
<i>Toxochelys</i>	100	58	50	51	73	100±	104±	70±

One might as well go on to prove that the "hawks-bill," *Eretmochelys imbricata*, is unable to "navigate the open seas".—For similarly:

	ARM.			FINGERS.				
	Humerus.	Radius.	Ulna.	1st.	2d.	3d.	4th.	5th.
<i>Amyda</i>	100	53	51	69	90	98	116	98
<i>Eretmochelys</i>	100	53	44	49	89	128	105	44

Whence the following differences:

	ARM.			FINGERS.				
	Humerus.	Radius.	Ulna.	1st.	2d.	3d.	4th.	5th.
<i>Amyda</i>	--	--	+7	+20	+1	--	+11	+54
<i>Eretmochelys</i>	--	--	--	--	--	+30	--	--

It is clear that save for that short thumb and long fourth finger of *Eretmochelys*, were this an extinct form, no conclusive evidence of the true flipper development would be afforded by such measurements as the above when considered alone. For it is a noteworthy fact that the disparity between the thumb and fourth finger of *Amyda* is +47 as against +53 in *Toxochelys*, and +56 in *Eretmochelys*. Yet as a true indication of unequal finger development, instead of disparity between only the short first and the long third and fourth fingers, as in *Eretmochelys*, there was in *Toxochelys* strong disparity between the short first and second and the long third and fourth fingers. There was also ulnar disparity.

All these fundamental numerical relations have been overlooked in Dr. Hay's criticism. He entirely ignores, too, the

fact that as a merely web-footed turtle *Toxochelys* would have been very unlike *Amyda*. For these percentual results must always be considered in connection with the humeral changes in the direction of marine forms, which are indicated in the thalassoid humerus of *Toxochelys*, as well as the enlargement of the pisiform to nearly the same size as in *Eretmochelys*. In short, it is evident that Dr. Hay overlooked important factors and that his views are untenable.

When I originally described the flipper of *Toxochelys* I was of the opinion that it represented the most primitive form yet discovered that could be called more distinctly marine than merely natatorial, long-fingered and web-footed; and now that I have had the present opportunity to briefly reconsider the subject I may say that I believe this interpretation in accord with the facts.\*

Dr. Hay "readily grants that the fore limb of *Toxochelys* had entered on the early stages of those modifications which resulted in the production of flippers." But as clearly enough indicated by the facts, much more modification had been undergone, and the foot was more a swimming than a walking one. Whether the third to fifth fingers were encased in a leathery hide, or still retained some of their freedom of motion, as in distinctly webbed types, is open to some question; but nevertheless finger disparity, reduction of the 3d-5th claws, pisiform enlargement and humeral change had all been accomplished to such an advanced extent that the limb is to be regarded as a flipper, quite admirably fitting *Toxochelys latiremis* to range the great inland Niobrara Sea. And even were the anatomical facts of less certain interpretation, the *onus probandi* would rest on him who asserted the non-marine nature of those turtles which occur so widely distributed in as extensive a chalk formation of indisputably marine origin as the Niobrara Cretaceous.

It is very evident, therefore, that on the basis of limb organization *Toxochelys* is a member of the Cheloniidæ, and that as proposed by the writer on the basis of the general organization, limb structure, and relationships the genus is most conveniently placed in the Chelonidan sub-family Toxochelydinæ.

As a concluding word it may be added for the sake of clearness that no great diagnostic significance is attached to the presence of the epi-neural ossicles,—certainly not if they are to be regarded as vestiges of a disappearing system, likewise indicated in the genus *Lytoloma* of the Cheloninæ.

Yale Museum, New Haven, Conn., Sept. 26, 1905.

\* In view of the great interest of the subject I will as early as convenient refigure the flipper of *Toxochelys* with all possible care. Dr. Hay is also of the opinion that the great turtles of the Fort Pierre, and perforce the Niobrara *Protostega* were likewise littoral and web-footed rather than marine. As will be incontestably demonstrated by the writer in a forthcoming Memoir of the Carnegie Museum of Pittsburgh, *Protostega* and *Archelon* were powerfully equipped for their marine habitat.



*Measurements of Carapace and Plastron of Toxochelys Bauri.*

(Yale Museum accession list 2823. Elements disarticulated and more or less altered in form by crushing in matrix. Recovered portions as shown in the accompanying figure 6 by the stippled surfaces.)

Length of carapace (estimated to within 1 or 2<sup>cm</sup> ..... 53<sup>cm</sup>  
 Breadth of carapace (greatest, as measured across the  
 anterior end of the 6th neural) ..... 40 +

	(a) Exact length on outer edge of carapace.	(b) Width measured at notch of the hornshield sulci.
Nuchal .....	12·0	--
1st marginal .....	6·0	2·5
2d " .....	5·0	2·5
3d " .....	5·9	2·8
4th " .....	6·0	--
5th " .....	6·5	2·8
6th " .....	7·0	3·3
7th " .....	7·5	--
8th " .....	8·0	4·5
9th " .....	7·5	4·5
10th " .....	7·0	4·5
11th " .....	6·8	4·5
Pygal .....	7·0	4·5

(The thickness and transverse sections of the marginals are approximately the same as in *Lytoloma angusta*. Owing to the crushing undergone by most of the marginals a closer approximation cannot readily be given.)

	Length on Median line.	Greatest width.
Nuchal .....	5·5	14·5
1st neural .....	3·8	3·8
2d " .....	4·4	3·7
3d " .....	4·4	4·0
4th " .....	4·6	4·4
5th " .....	3·4	4·5
6th " .....	5·0	4·0
7th " .....	4·0	3·8
8th " .....	2·5	3·5
9th " .....	1·5	3·5
(10th) " .....	2·5	3·4
Antero-pygal .....	4·5	5·9
(Postero-pygal) .....	(3·5)	(4·0)
Marginalo-pygal .....	4·5	6·5

1st epi-neural ossicle .....	3.5	1.7
2d " " .....	4.5	2.0
3d " " .....	3.9	1.5

(Thickness of 2d neural measured through carina, 1.4<sup>cm</sup>.)

(The total height of the epi-neural ossicles is respectively, 15, 21, and 15<sup>mm</sup>, the projection above the carina, 9, 12, and 9<sup>mm</sup>.)

	(a) Length over curvature.	(b) Length of posterior sutural border.	(c) Median width.
Nuchal .....	---	[10]	--
1st pleural .....	15.0	6.5	5.7
2d " .....	18.5	8.4	5.5
3d " .....	19.5	8.4	5.0
4th " .....	19.5	8.2	4.9
5th " .....	19.0	7.7	4.8
6th " .....	17.5	6.9	4.5
7th " .....	14.5	5.1	3.8
8th " .....	11.5	2.2	3.8

(The average thickness of the pleurals is 50<sup>mm</sup>. The distance between the bases of the rib-capitulae of the 7th pleurals is 4<sup>cm</sup>. The large pleuro-marginal fontanelles are approximately one-half, or more than one-half the length of the pleurals which bound them. The hornshield sulci, save for the notched marginals, are indistinct.)

*The Plastron.* (Cf. figure 7.)

Length on median line.....	39 ± <sup>cm</sup>
Greatest width .....	36 ±

(With added width of the inferior faces of the adjoining marginals, or 2<sup>cm</sup> × 2, this measurement yields as the approximate breadth of the carapace 40<sup>cm</sup>.)

Width (on antero-posterior line) of the marginalo- hyo-hypoplastral fontanelle.....	5.0
Length of hyo-hypoplastral suture .....	6.3
Least width of the hyo-hypoplastral bridge .....	11.0

## References.

1. Boulenger, G. A. : Catalogue of Chelonians, British Museum of Natural History, 1889.
2. Case, E. C. : *Toxochelys*. University Geological Survey of Kansas, Paleontology, Part IV. Topeka, 1898.
3. Cope, E. D. : Vertebrata of the Cretaceous Formations of the West, vol. ii, Rep. U. S. Geological Survey of the Territories. Washington, 1875.
4. Fraas, E. : *Proganochelys Quenstedtii* Baur (*Psammochelys Keuperina* Qu.). Ein neuer Fund der Keuper-schildkröte aus dem Stubensandstein. Jahreshefte des Ver. für Naturk. in Württemberg. Stuttgart, 1899.
5. Gray, J. E. : Supplement to the Catalogue of Shield Reptiles in the British Museum. London, 1870.
6. Hay, O. P. : On the skeleton of *Toxochelys latiremis*. Publications of the Field Columbian Museum. Zool. I. Chicago, 1895.
7. ——— On the group of Fossil Turtles, known as the Amphichelydia ; with Remarks on the Origin and Relationships of the Suborders, Superfamilies, and the Families of the Testudines. Bull. American Museum of Natural History, vol. xxi, Article IX. New York, June 30, 1905.
8. ——— A Revision of the species of the Family of Fossil Turtles called Toxochelyidæ, with Descriptions of two New Species of *Toxochelys* and a New Species of *Porthochelys*. Ibid., Article X.
9. Wieland, G. R. : *Archelon ischyros* : A new gigantic cryptodiran Testudinate from the Fort Pierre Cretaceous of South Dakota. Ibid., vol. ii, Dec., 1896.
10. ——— Notes on the Cretaceous Turtles *Toxochelys* and *Archelon*, with a classification of the Marine Testudinata. Ibid., vol. xiv, Aug., 1902.
11. ——— Structure of the Upper Cretaceous Turtles of New Jersey: *Adocus*, *Osteopygis*, and *Propleura*. Ibid., February, 1904.
12. ——— Structure of the Upper Cretaceous Turtles of New Jersey: *Lytoloma*. Ibid., Sept., 1904.

ART. XXXVII.—*Contributions to the Geology of New Hampshire. I. Geology of the Belknap Mountains*; by L. V. PIRSSON and H. S. WASHINGTON. (With Plate XI.)

*Introductory Note.*—Our object in this paper and in one to follow it is to present the results of a study made in the field and in the laboratory of the occurrence and characters of a group of igneous rocks from a locality about which little is known. Our field work was done in two visits to the area and covers a period of between two and three weeks, during which it was traversed and roughly outlined and the highest peaks and ridges ascended. This was sufficient to give a good general idea of its geology and of the various rock types. In the lack of a suitable base map on a sufficient scale, upon which to make record, more detailed and careful work was not warranted and would have enabled us to add little of interest to the general results presented in this paper. The map used and upon which our results are given is taken from that accompanying the Hitchcock Survey, referred to later, and which we have modified to some extent. The topography is more or less generalized and in places somewhat inaccurate, but it is the only one showing topography of which we have any knowledge and it has served as the basis of several topographic maps since published for the use of tourists which we have also consulted.

LOCATION AND GEOGRAPHY.

The Belknap Mountains form an elevated tract south and west of Lake Winnepesaukee in New Hampshire and lying in the townships of Gilford, Alton and Gilmanton. Although they are sometimes referred to as the "Belknap Range" they do not form a mountain range of the anticlinal type, being the irregular, eroded upper portion of a great intrusion of igneous rock of a generally granitic character. In its greatest length, which is northwest and southeast, the mountain tract extends about eleven miles and its width at the broadest point east and west is about six miles. In shape the mass is triangular, the long side facing the west composed of the main ridge which carries the highest summits, while an eastward extension produces the triangular shape. At the eastern end of the triangle there is an extension running southward. On the north and east sides the slopes descend into Lake Winnepesaukee; on the west and south into a much lower, irregularly hilly country. The drainage on the west is carried off by the Gunstock River, which in its course of about six miles runs due north at the foot of the mountain slopes in a valley cut along the contact

zone of the igneous rock mass. On the south the drainage is less clearly defined and is carried off through a series of small lakes which empty to the southward. On the other sides small brooks run into the lake. The mountains are quite generally covered with trees and brushwood on the steeper slopes; below these are generally open pasture fields, and the highest crests and summits are more or less bare rock exposures with small meadows between them. At the foot of the eastern and northern slopes, along the shore of Lake Winnepesaukee, runs the Lake Shore Railroad, a branch of the Boston and Maine Railway system, which ends at Lakeport-Laconia. These towns with Alton Bay at the south end of the lake and the village of Gilford are the most important places in the vicinity of the mountains, although the shore of the lake at their foot is thickly dotted with summer cottages and places of resort. Around them elsewhere is an open farming country and the high valley between the northern extension and the eastward one of Mount Straightback is also a cultivated area reached by a road over the mountains from Gilford to West Alton.

*Historical.*—The only reference in the literature to the geology of the Belknap Mountains which we have been able to find is the short description by Hitchcock.\* He states that the mountains are composed of eruptive syenite similar to that of Red Hill in Moultonborough. He describes briefly a few localities, and mentions that in places it is in contact with porphyritic gneiss and mica schist. He thinks that the syenite has come up through a synclinal fault. Near the contact with the porphyritic gneiss it is brecciated and full of dark hornblendic spots. He alludes to a "trap" dike ten feet wide cutting the syenite in one place, and says that reddish feldspathic veins are common. This is an evident reference to one of the lamprophyric dikes and the felsitic ones. He also refers to a breccia which is found in one locality, the coarser syenites occurring as nodules in a rock resembling trap. The mass of diorite (camptonose) rock above the Gilford station on the lower west slope of Locke's Hill is not mentioned and was probably not seen by him. In Hawes'† report the rocks of this area are not mentioned, although he describes the syenite of Red Hill.

#### GEOLOGY OF THE BELKNAP MOUNTAINS.

The Belknap Mountains are formed of a mass of granitic igneous rock, the result of the upthrust of a great body of molten magma into the rock masses surrounding it, the latter being broken and displaced to permit of its entry. In sequence to this major event there were later upthrusts of other magmas

\* *Geology of New Hampshire*, vol. ii, p. 607, 1877.

† *Lithology of New Hampshire*, loc. cit., vol. iii.

of different composition in small amounts which now appear as accompanying intrusive masses and dikes. Since then the superincumbent rocks have been removed by long-continued erosion, which has also bitten deeply into the igneous mass as well, but this has resisted better than those which surround it, and in consequence the igneous stock now projects as a rough mountain tract. Lastly, much material was removed at the time of the glacial invasion and the rock surfaces left scored and polished.

*The enclosing rocks.*—These are mostly gneisses and mica schists, rocks of metamorphic character. Although they do not especially concern us in this paper, a word or two may be added regarding them. On the eastern side the contact is with a heavy solid gneiss, composed of quartz, alkali feldspars and biotite, and often carrying red garnets. In its texture it is rather irregular, not presenting that evenness of aspect frequently shown by gneissoid granites, and it is possible that detailed study in the future may show that it is of sedimentary origin. It has a wide extension in this general region and has been called the Winnepesaukee gneiss by the Hitchcock Survey.

In Mount Major and Pine Mountain are two small masses of a porphyritic granite as shown on the map of the Hitchcock survey. In their report it is spoken of as the porphyritic gneiss. It covers a large area to the north of this region, where we have seen and studied it to some extent. By its general characters, contact modifications, etc., it is clearly an igneous rock—a granite which carries large, often huge, phenocrysts of orthoclase. It occurs in other parts of New England and is a type worthy of especial study. It sometimes has a pronounced gneissoid structure which evidently is often a fluxion texture, at other times it is due to dynamic shearing and in some places it is quite devoid of any gneissic character.

On the west and south the Belknap massif is in contact with micaceous gneisses, micaceous slates colored dark with organic matter and iron ore and with mica schist rocks evidently of sedimentary origin. The boundaries and names of these formations are those given on the Hitchcock map. The lack of printed symbols on this map connecting the legend with the outlined areas and the great similarity of colors makes it exceedingly difficult, in many cases impossible, to determine what some of these areas are meant to be, nor does the text afford much help in this direction. The formations are mentioned in many places, but there is no definite description of them given in a systematic manner by which their characters may be recognized. From what is stated,\* however, we conclude that the rocks on the west belong to the Montalban series

\* *Op. cit.*, vol. ii, p. 600.

of Hitchcock, and they are so designated on the map. Where we have seen them they are mostly gray micaceous gneisses and mica schists.

*Geology of the main mass.*—The greater part of the mountain group is made up of a coarse-grained hornblende syenite, a *hornblende-grano-pulaskose* in the new classification, whose characters will be given in a succeeding petrographical paper. It is this rock which composes the mass of Mt. Gunstock, of Mt. Belknap the peak next north of it and of the northern extension in Locke's Hill. It occurs also in the ledges exposed on the higher part of the road from Gilford to West Alton, where it crosses over the mountain. It also forms the higher parts of Piper Mountain south of Gunstock Peak, and it runs over towards Mt. Straightback. In Piper Mountain it assumes a somewhat porphyritic character. It is seen on the sides and crests of the main elevations in massive outcrops and exposures often several hundred feet across and is thus thoroughly laid bare. These surfaces show everywhere the planing and smoothing of glaciation. In none of them did we find the rock perfectly firm and unchanged. Everywhere its color ranges from a reddish to brownish, it tends to crumble under the hammer and in places it is loose and crumbling into coarse gravel. The chemical analysis shows however that this is not due to any chemical alteration of the constituent minerals, but to mechanical disintegration from the action of frost and weathering, which have tended to loosen the texture of the rock. Blasting would probably reveal excellent material at a few feet below the surface. We did not find any quarry openings in this rock-material; it is in general too high above the zone of cultivation to have made such work necessary. In only one place did we find this type at the contact zone against the older rocks, on the southwest slope of Locke's Hill in a little ravine where it is in contact with mica schist. It is here rather coarse, altered and not of typical composition.

*Contact facies of fine-grained granite.*—With the exception just mentioned, in all localities examined by us, we have found that at the contact with the enclosing rocks, not the syenite but a fine-grained granite (*grano-liparose*) is present. The lower slopes where the actual contact lies are in general so covered with glacial drift and soil, often with a more or less dense growth of vegetation, that it is masked and rarely seen, but immediately above where it should be this granite appears and beyond and above it the syenite. This we found to be the case in a number of places on different sides of the mass, so for example at the west foot of Mt. Gunstock, the west and south slopes of Piper Mountain, the northeast foot of Locke's Hill, at West Alton and on the southern prolongation of the

mass northeast of Hill's Pond. Hitchcock's description also gives clear indications of the same thing in other localities not visited by us. One of the best localities for the study of the contact that was seen by us is at the foot of the west slopes running down from the north end of Piper Mountain in the pasture fields south of Morrill's farm, where the path, by which Mt. Gunstock is generally ascended, begins. The mica schists and other rocks, which we infer make the formation shown by Hitchcock on his map as the Montalban, are full of pegmatite and fine granite stringers and dikelets and appear to be enriched in feldspar. As the contact is approached they change to a fine dark-gray gneiss which is cut by fine granite dikes. Higher up appears the syenite itself. The attitude and characters of the gneisses are such that they indicate quite clearly that they lie, thinning out toward the mountain, upon a rising slope of the igneous rock below and that the contact plane is therefore here not vertical but dipping away from the mountain. The syenite from the slopes above is that of the main type but finer-grained. At the south end of Piper Mountain the bordering granite has a faint but distinct gneissoid appearance. It is also to be noted that these bordering masses of granite are generally filled with spots and streaks of variable size of darker inclusions, which are no doubt fragments of the country rock thoroughly altered by immersion in the magma.

It appears to us that the best explanation for these fringing granite masses is to consider them a differentiated border facies, an endomorphic contact modification of the main type. They may not exist everywhere, but they have been so generally found on different sides, as seen by ourselves and indicated by Hitchcock, that the phenomenon seems difficult of explanation on any other basis. It is true that we have not been able on continuous exposures to trace the gradual merging of the granite into the syenite, because this should be done on the lower slopes, and for reasons given above these do not afford proper exposures for this purpose. We cannot affirm then positively that these are not a series of later eruptions which have broken out around the border of the previously intruded syenite, but in view of their disposition such an explanation seems unnatural, and especially so since they do not exhibit certain phenomena shown by an undoubted later intrusion of granitic magma on the western slope of Locke's Hill, which will be presently described. From the facts at our command, therefore, we are inclined to think the first explanation the more reasonable one and to regard the granite as a differentiated border mantle of the syenite. We also do not regard the granite border as having been produced by the melting up



Geologic and Topographic Map of the Belknap Mountains, N. H.

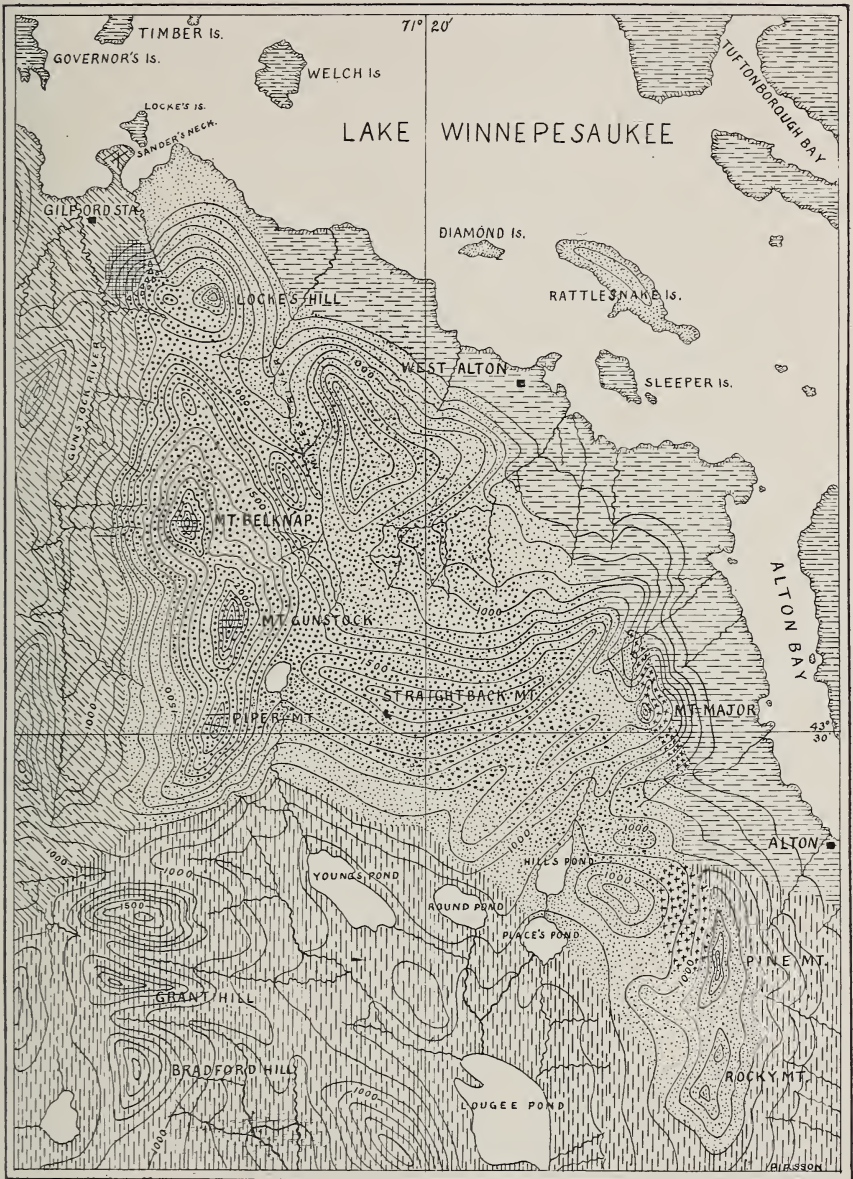

Syenite. Granite. Diorite and breccia. Porphyritic Gneiss. Winnepe-saukee Gneiss. Montalban Series? Cambrian? Rockingham mica schist.

Scale 1 inch = 2 miles. Contour interval = 100 feet.



and absorption of the country rock with which the mass of syenite magma came in contact for two sufficient and convincing reasons. First, because as already shown, the surrounding rocks differ widely in character and in chemical composition in different places, while the granite border maintains everywhere essentially the same characters, and second, because in many places inclusions of the country rock are to be seen in it which, without regard to size, preserve all the sharpness and angularity of their original fragmentary form, thus showing that, although they have been much metamorphosed, melting of them did not occur. On the highest peaks and ridges and in the deepest erosive cuts into the mass it has been worn away and the main type of syenite appears. Its thickness was quite variable, and in a few places it did not appear at all. The line between the syenite and granite as shown on the geological map is therefore to be taken as a generalized expression of the existence of the two types and not as a definite geological boundary line, since for reasons just given this could not be definitely determined.

*Gilford diorite area.*—On our first visit to the region we found quite abundantly distributed in the form of bowlders in the fields and stone walls of the fences along the higher part of the land from Gilford over to West Alton, a most peculiar dark rock composed of large dark-brown hornblendes poikilitically enclosing ophitic feldspars. In field usage it is here called a diorite for purposes of geologic description; petrographically it is, as will be shown later, a grano-hornblende-camptonose, or in the older systems an Essexite. On our second visit an especial search was made to locate if possible the occurrence of this type, and it was found to constitute a considerable mass on the lower west slope of Locke's Hill and not far from the Gilford station on the railway. Its area is small, probably not over half a mile in length north and south along the slope and less than that in breadth. On the north it rises in heavy ledges above a little spring drainage and on the west its lower slopes are covered with soil and debris, but above this it forms a rather well-defined bench on the lower mountain side and in rather prominent outcrops it is seen everywhere over the pasture fields which lie upon it. On the south it descends into a little ravine, a locality mentioned above in connection with the syenite, and is here in contact with the mica schists and gneisses. Its upper edge is in contact with the syenite, but the actual contact was everywhere covered so far as we could discover. We have traced it, however, to within a few yards distance, and it is then observed that the rock diminishes very strikingly in the size of its grain, especially so with regard to the large poikilitic hornblendes, and for this reason and others to be mentioned later we believe

it to be a later intrusion than the syenite and that it has broken up alongside of it. The upper contact with the syenite is, however, largely replaced by a remarkable breccia zone to be presently described. This rock varies considerably in characters from place to place, as will be described in a succeeding petrographic paper.

*Breccia zone.*—As just mentioned, the contact between the diorite and syenite above is occupied by a brecciated rock mass. The cement is a quartz-alkali feldspar rock much like the granite facies previously described; it has a sugar granular texture, and is of the character of rocks designated as aplites. In this are thickly scattered blocks of all sizes, which may attain an extreme dimension of four feet in length but which average perhaps a foot or two in diameter and descend from this size to minute fragments of a fraction of an inch. In some places they are so thickly crowded that their mass is much greater than that of the cement. In shape they are usually extremely angular and the sharpness of the angles has been perfectly preserved. In other cases they appear somewhat rounded as if partially melted, and are surrounded by darker aureoles richer in ferromagnesian minerals. It is remarkable, on the other hand, how some of the smallest fragments retain in some cases all their distinctness of outline. There are several different types of rocks among these included fragments. One common one is a dense black basaltic-looking type too compact for the component minerals to be seen, in which lie phenocrysts of mica and other minerals—a rock of well defined lamprophyric character. Other fragments are of the diorite mentioned above, while others are obviously pieces of gneisses and schists.

The determination of the relative age of this breccia and of the syenite and diorite is not easy. It would be simple to imagine that the latter is the older rock, that the syenite with its granite border broke up alongside of it enclosing masses of femic rock. If this view is adopted, then the basaltic, lamprophyric and granitic and felsitic dikes which cut the syenite must of course be separate and later intrusions and there would be four periods of eruption, in two of which, those of the diorite and the lamprophyric dikes, similar magmas were produced. The oldest rock, the diorite, is then also the most differentiated one, a fact contrary to general experience. Considering these points, we are inclined to believe the syenite the first and oldest, to place the eruption of the diorite next, which would also explain the distinct endomorphic contact modification it exhibits toward the syenite and make it contemporaneous with the lamprophyric dikes. Then came an eruption of granitic magmas, which also forms dikes in the syenite, one of

which broke up at the border of the diorite, involving masses of it in its various modifications and thus produced the breccia. If this view is adopted, there are but three periods of eruption and they follow the normal course commonly seen in such cases.

*Dikes.*—It has been observed by us that wherever the main types of igneous rocks are exposed over considerable areas in this mountain tract they are commonly cut by dikes, and the same is true of the border zone of the enclosing schists and gneisses. Except, however, in the highest parts of the mountains, such exposures are not very common nor are they of great size. It seems probable, therefore, that only a very small part of the dikes actually present in the region has been seen by us, the greater part being covered up by the heavy mantle of debris and glacial drift.

As is so often the case when the dikes are found to be a throng of satellites attendant upon a large body of igneous rock, they may be readily referred to two strongly contrasted groups. In one of these the rocks are light colored, strongly persalic and therefore almost devoid of ferromagnesian minerals; in the second the rocks are dark colored, saffemic, heavy and composed in very large, if not for the greater part, of ferromagnesian minerals. They are persalanes and saffemanes in the new classification or aplites and camptonites in the older ones.

The *persalane* dikes are found cutting the main syenite in all directions, of a generally pink color and varying in size from dikelets but a few inches in breadth to masses twenty feet wide. The bare exposed slopes and ledges of the upper part of Mt. Belknap were found cut by them in great abundance and it was here noticed that they often ended abruptly and appeared as if somewhat elongated roughly lenticular masses. They were often branched, were connected with others, anastomosed or formed reticulated systems, large and small together. Their small angular chippy jointing, light color on the weathered surface and flinty felsitic aspect clearly distinguished them from the massive granular rock they cut. These same characters were found repeated on the exposed surfaces of Mt. Gunstock and Mt. Piper, and in one place, about half way up Mt. Gunstock from Morrill's house, on the west slope above the spring, the ledges in a pasture field on an open shoulder of the mountain were found cut by a dike of this nature 15-20 feet in width and with north and south trend. It was also found that where the contact zone was exposed at the foot of the mountain slopes, as along the west side in the localities described above, that both the igneous rock and the enclosing schists and gneisses were cut by dikes and stringers

of persalitic rock. While in the crest of the ridges and in the peaks these dikes vary in texture from dense felsitic to sugar granular granites, in the contact zone we observed only the latter, and they sometimes pass into varieties with pegmatoid texture.

With only a few exceptions all of these occurrences are on too small a scale to be shown on the map. The *salfemane* dikes were not nearly so numerous, but on account of the contrast made by their dark color appear more distinctly defined. They were also observed cutting the exposed rock surfaces on the tops of the mountains; there are several below the summit of Mt. Belknap on the southwest side and one six feet wide with porphyritic feldspars cuts the very highest point of the peak with east and west trend. Three or four of about the same size were found on the top of Mt. Gunstock and they were likewise observed on the crest of Mt. Piper. The lower slopes of the mountains are probably cut by them also, but the masses of debris and vegetation which cover them hide the exposures in which they might be seen.

They occur also in the surrounding rock masses in which the intrusion took place. Here again the exposures are difficult to find, but one place, Sander's Neck, a small promontory on the shore of the lake north of the mountains, presents considerable areas of the glaciated gneisses, and these we found traversed by several intersecting dikes of these salfermic rocks. As usual they were but a few feet in width. They occur in the mica schists which are exposed at the foot of the lower west slopes of Mt. Gunstock and Mt. Piper, and from what we have observed around the similar intrusive mass of Red Hill north of the lake, it seems probable that a more detailed study of the surrounding region would show a considerable number of them extending to relatively long distances from the central parent mass. Some of those mentioned above are shown on the accompanying map.

New Haven, Conn., and Locust, N. J., May, 1905.

ART. XXXVIII.—*The Fauna of the Chazy Limestone* ;\* by  
PERCY E. RAYMOND.

INTRODUCTION.

IN several papers on the Chazy limestone, Brainerd and Seely have given sections showing the lithological characters and thickness of the rocks at various localities from Chazy, New York, south to Orwell, Vermont.† These authors have divided the formation into three parts, A, B, and C, of which A is the base and C the top. These divisions are founded partly on lithologic and partly on paleontologic grounds. Only a few species of fossils, however, were listed; hence it has been the object of the present writer to ascertain which are the common species in the Chazy, and to learn their stratigraphic and geographic distribution. For this purpose, detailed sections have been made at Crown Point, Valcour Island, and Chazy, and extensive collections have been obtained at other places in the Champlain and Ottawa valleys. The sections will be fully described in the *Annals of the Carnegie Museum*. In this place, however, only a synopsis of each is given.

DISTRIBUTION.

The Chazy formation was named by Ebenezer Emmons‡ from the outcrops studied by him at Chazy village, New York, this locality, therefore, becoming the typical one for the formation.

In stratigraphic position, the Chazy overlies the Beekmantown (Calcareous) and underlies the Lowville (Birdseye) member of the Mohawkian. It may be traced from Orwell, Vermont (along the Champlain Valley), to Joliette, north of Montreal, Canada. In the Ottawa Valley, it extends from Hawksbury west to Allumette Island, 80 miles northwest of Ottawa. The formation is seen again at the Mingan Islands in the St. Lawrence, where it covers a small area.

In the Lake Champlain region, these strata are mostly limestone, and the thickness ranges from 60 feet at Orwell to 890

\* Abstract of part of a thesis presented to the Faculty of the Yale University Graduate School for the degree of Doctor of Philosophy. The detailed paper, with full discussion and illustration of species, will be published in early numbers of the *Annals of the Carnegie Museum*. For description of the trilobites here mentioned, see *Annals of the Carnegie Museum*, vol. iii, p. 328, and this *Journal*, vol. xix, p. 377. Other new forms noted in the text are described at the end of the present paper.

† *Amer. Geol.*, vol. ii, p. 323, 1888; *Bull. Geol. Soc. Amer.*, vol. ii, p. 300, 1891; *Bull. Amer. Mus. Nat. Hist.*, vol. viii, p. 305, 1896.

‡ *Geology of New York*, Pt. 2, Report of the Second District, 1842, p. 107.

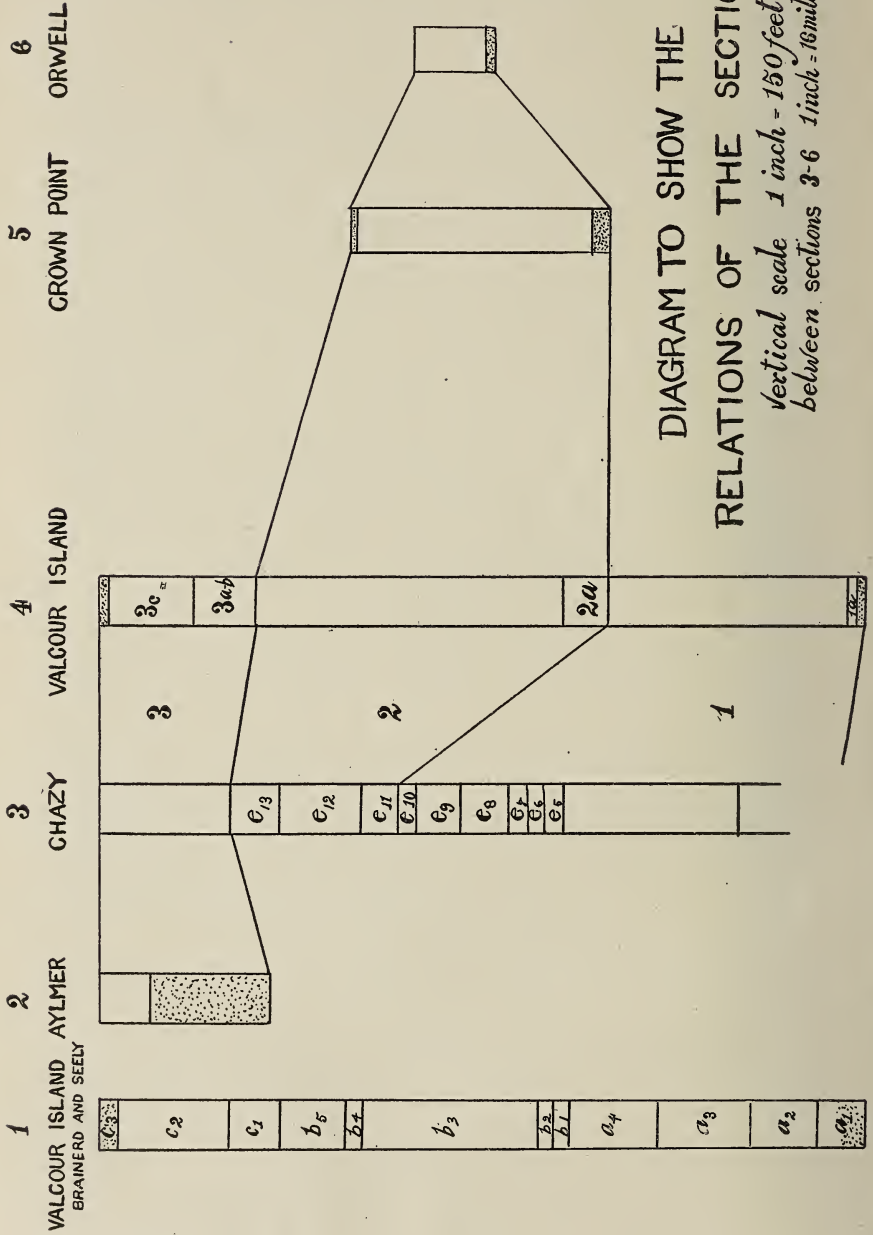



feet at Valcour Island. Further north the thickness is not definitely known. In the Ottawa Valley, the formation is usually from 100 to 200 feet thick and is about half limestone and half sandstone, the former usually overlying the latter. At the Mingan Islands, the thickness was estimated by Sir William Logan at about 300 feet, and the strata include both shales and limestone.

#### LAKE CHAMPLAIN REGION.

As the typical Chazy is exposed in the Lake Champlain region, that area will be first taken up. In general, the Chazy rocks are seen as a narrow belt running almost north and south from Orwell, Vermont, to Joliette, Canada. The area is seldom more than 10 miles wide, and is not a continuous exposure, but occurs in small patches, in most cases evidently fault blocks, and the strata are usually inclined at a considerable angle. The principal outcrops are along the west side of Lake Champlain and on the islands in the northern part of the lake. South of Willsboro Point, there are scattered patches on both sides of the lake nearly to Fort Ticonderoga.

#### Faunal Divisions.

In the Lake Champlain region, three major faunal divisions of the Chazy may be distinguished. Within these, there are again various zones which are more or less local in geographical extent.

*Division 1. The Hebertella exfoliata Division.*—The strata of this basal division are chiefly light-colored, impure, rather coarse-grained limestones and frequently have shaly partings. The thickness varies from nothing at the south end of Lake Champlain to 300 feet on Valcour Island, 365+ at Chazy, and 225 feet on Isle La Motte.

The characteristic fossils are: *Hebertella exfoliata* sp. nov., *Orthis acutiplicata* sp. nov., *Strophomena prisca* sp. nov., *Scenella pretensa* sp. nov., *S. montrealensis*, *Palæacmæa irregularis* sp. nov., *Raphistoma immatura*, and *Scalites angulatus*. Other species occurring abundantly in this zone are: *Blastoidocrinus carchariædens*, *Bolboporites americanus*, *Zygospira acutirostris*, *Raphistoma stamineum*, *Lophospira subabbreviata*, *Bucania sulcatina*, and *Pseudosphærexochus chazyensis*. Those which occur only rarely in this division, but which thus far have not been found in higher divisions, are: *Lingula belli*, *Cyrtodonta solitaria* sp. nov., *Cyclonema? normaliana* sp. nov., *Eunema leptonotum* sp. nov., and *Heliomera sol.*

Of the 141 species in the Chazy whose range is known, 64 make their first appearance in this horizon and 23 are found in

all three divisions. This member is further marked by the appearance of the earliest of American Bryozoa, and these, unlike most Ordovician species, range throughout the entire formation above the sandstone.

Division 1 is characterized by the predominance of individuals and species of Brachiopoda. Fourteen of the 25 species of this group occurring in the Chazy of the Champlain Valley are found in this lowest member, while only 2 of the 16 pelecypods are represented. Exactly half the species of trilobites are also found here, but specimens are not common. Gastro-pods are more numerous, as half the species are represented and individuals of some forms are abundant. They do not occur in the lower strata, but are confined almost entirely to the upper part.

There are three zones in this division which are worthy of notice:—

Zone 1<sub>a</sub>, or the *Orthis acutiplicata* zone, is near the base of the division and is found at Valcour Island and Isle La Motte. The characteristic fossils are: *Orthis acutiplicata*, *Rafinesquina incrassata*, *Isotelus harrisi*, and *Thaleops ovata*, all long rangers except the first.

Zone 1<sub>b</sub>. The *Scalites angulatus* zone. The faunule of this zone is found at Plattsburg and Chazy. It is located near the middle of Division 1. The characteristic fossils are: *Scalites angulatus*, *Raphistoma immaturum*, *R. stamineum*, *Bucania sulcatina*, *Camarella longirostris*, *Illænus globosus*, and *Thaleops ovata*. Only the first two are restricted to this horizon.

Zone 1<sub>c</sub>, the *Lophospira subabbreviata* zone, has been found only at Chazy, but is very strongly marked. It occurs about 75 feet below the top of Division 1. The characteristic fossils are: *Lophospira subabbreviata* and *Raphistoma stamineum*, both of which are very abundant. Of less importance are the rare *Schizambon? duplicimuriatus*, *Heliomera sol*, and *Clionychia marginalis* sp. nov.

Division 2. The *Maclurites magna* Division.—The strata of this middle division are usually heavy bedded, dark blue and grey, fairly pure limestones, with an occasional layer of grey sparkling dolomite or of light coarse-grained limestone. The layers near the middle usually weather into nodular masses, and the fossils are frequently poorly preserved and difficult to extract. The thickness varies from 200 feet at Chazy to 400 at Valcour Island, and decreases toward the south. The characteristic fossils are: *Maclurites magna*, *Rafinesquina champlainensis*, *Plasiomys platys*, *P. strophomenoides* sp. nov., *Strophochetus*, *Eospongia varians*, *Eotomaria obsoletum* sp. nov., *Eccyliopterus fredericus*, *Bathyporellus minor*, *Glaphurus primus*, and *Leperditia limatula* sp. nov.

Thus far, the following fossils have been found only in this division, and most of them in but one locality: *Camarotechia pristina* sp. nov., *Otenodonta dubiaformis* sp. nov., *Clidophorus obscurus* sp. nov., *Cyrtodonta expansa* sp. nov., *Endodesma undulatum* sp. nov., *Scenella robusta* sp. nov., *Raphistoma undulatum* sp. nov., *Helicotoma vagrans* sp. nov., *Bucania bidorsata?*, *Trochonema dispar* sp. nov., *Subulites prolongata* sp. nov., *Holopea scrutator* sp. nov., *Eoharpes ottawäensis*, *Asaphus marginalis*, *Isotelus angusticauda*, *Isotelus?* *bearsi*, *Illeenus punctatus*, *Cybele valcourensis*, *Ceraurus pompilius*, *C. hudsoni*, and *Pseudosphærexochus approximus*.

This middle division is marked by an abundance of pelecypods, gastropods, and trilobites, and in this respect is sharply contrasted with the lower division. Of the 16 pelecypods, 13 are represented here. Of 35 trilobites, 27 are present.

Species of *Stromatocerium* and *Strephochetus* are common in these rocks, but are also abundant in the lower zone of the next division.

Zone 2<sub>a</sub>. The *Malocystites murchisoni* zone. Thus far, only one subfaunule has been detected in Division 2, and that is at the very base. It is best developed at Valcour, but occurs also on Valcour Island. The zone is characterized by the great abundance of cystid fragments. The characteristic fossils are: *Glaphurus primus*, *Eoharpes antiquatus*, *Lonchodomas halli*, *Cybele valcourensis*, *Malocystites murchisoni*, *M. emmonsii*, *Glyptocystites forbesi*, *Palæocystites tenuiradiatus*, *Raphistoma stamineum*, *Maclurites magna*, *Plasiomys strophomenoides*, and *Camarella varians*.

Division 3. The *Camarotechia plena* Division.—The strata of this division are rather thin bedded, light grey, coarse-grained limestones, abounding in fossils. Near the base there are always buff-colored, pure, fine-grained dolomites and heavy bedded, coarse-grained blue limestones. The only fossil which is found throughout this division is *Camarotechia plena*. Other characteristic fossils are: *Camarotechia major* sp. nov., *Orthis ignicula* sp. nov., *Modiolopsis fubaformis* sp. nov., and *Glaphurus pustulatus*.

There is here a decided falling off in the number of gastropods and pelecypods, only 6 of the former and 5 of the latter being represented. There are about as many trilobites (16) in this division as in Division 1, and 8 of these are found in all three sections. The number of species of brachiopods is about the same in each of the three divisions, but they dominate the fauna in the first and third. In the former, one of the Protre mata (*Hebertella*) is most abundant, while in the third division one of the Telotre mata (*Camarotechia*) predominates.

There are three well-marked zones in this division, as follows:

Zone 3<sub>a</sub>, the *Glaphurus pustulatus* zone, is found at the base of Division 3, at Valcour Island, Chazy, Cooperville, and Isle La Motte. The characteristic fossils are: *Glaphurus pustulatus*, *Ilænus globosus*, *I. erastusi*, *Isotelus harrisi*, *Remopleurides canadensis*, *Pliomerops canadensis*, *Amphili-chas minganensis*, *Pseudosphærexochus vulcanus*, *Camarotæchia plena*, *Conocardium beecheri* sp. nov., *Bucania sulcatina*, and several cephalopods.

Zone 3<sub>b</sub>, the *Camarotæchia major* zone, stands between 3<sub>a</sub> and 3<sub>c</sub> and its faunule is a transition between the two. *Camarotæchia* becomes more abundant and better developed, and fossils, while numerous, become fewer in species. The best development is at Valcour Island. The characteristic fossils are: *Camarotæchia plena*, *C. major*, *Hebertella costalis*, *Malocystites emmonsii*, *Malocystites* sp., *Palæocystites* sp., *Ilænus globosus*, *Pliomerops canadensis*, *Bucania sulcatina*, *Raphistoma stamineum*, and *Isotelus obtusum*.

Zone 3<sub>c</sub>. The *Modiolopsis fabaformis* zone. In this zone, *Camarotæchia plena* is abundant, almost to the exclusion of other species. The faunule extends to the top of the formation at Chazy, Grand Isle, and Valcour Island. The characteristic fossils are: *Camarotæchia plena* and *Modiolopsis fabaformis*.

#### Section at Chazy, New York.

The section at Chazy has a thickness of 732 feet, but the base of the formation is not shown.

*Division 1.*—The rocks carrying the fauna of Division 1 are well exposed in the ridges south of the village, near Tracy Brook. The thickness is 365 feet, and judging from the fauna at the base, at least 150 feet of strata are missing. *Hebertella exfoliata* is very abundant, especially below the horizon of *Scalites angulatus*. The latter zone is 217 feet above the base of the exposed section, and is zone 1<sub>b</sub> of the generalized section. The most common fossils are: *Scalites angulatus*, *Bucania sulcatina*, *Raphistoma immaturum*, *R. stamineum*, and *Thaleops ovata*. Higher up in the section, 275 feet above the base, is the zone of *Lophospira subabbreviata*, about 35 feet in thickness. This is zone 1<sub>c</sub> of the generalized section. The gastropods are very abundant in the three localities at Chazy where this zone is exposed.

*Division 2.*—The strata of this division are about 195 feet in thickness, and are dark blue, impure nodular limestones, usually full of fossils which are frequently silicified. *Stroma-*

*tocerium*, *Eospongia varians*, *Rafinesquina champlainensis*, *Plasiomys platys*, *Maclurites magna*, *Pliomeroys canadensis*, and several cephalopods are common.

*Division 3.*—The *Camarotoechia plena* division is not very well developed along the line of the section at Chazy. The thickness is 156 feet, but a large part of the strata is covered with soil. At the base are about 25 feet of grey dolomite with almost no fossils. The remainder of the rock, as far as exposed, is an impure shaly limestone, abounding in *Camarotoechia plena*. Zones  $3_a$ ,  $3_b$ , and  $3_c$  can not be distinguished just at Chazy village, probably because the strata are so poorly exposed. About 3 miles southeast of this point, however, in a field near the lake shore, fine outcrops of zone  $3_a$  occur, and here *Glaphurus pustulatus*, *Amphilichas minganensis*, *Illenus globosus*, and the cephalopods are common.

#### Section at Valcour Island.

On Valcour Island, the whole of the Chazy is exposed, with a thickness of 890 feet. In one section along the south end, almost the entire thickness is shown, while nearly all the missing parts may be seen in other sections on the east and north sides of the island.

*Division 1.*—The strata of this division are well exposed on the south end. The thickness is 314 feet. At the base is a zone of sandstone and shale in which *Lingula brainerdi* is the common fossil. Other fossils are rare, *Isotelus harrisi* and a species of *Eccyliopecterus* being the only ones thus far found. Above this zone is that of *Orthis acutiplicata*, 10 feet in thickness.

The *Scalites angulatus* zone is not exposed on Valcour Island, the rocks usually containing it being absent at the pebble beach on the south end of the island. The *Lophospira subabbreviata* zone is not well developed, but may be indicated by a fauna found on the middle of the west side.

*Division 2.*—The strata of this division are 406 feet in thickness and are usually compact, dark blue and grey limestones. The fossils are frequently coarsely silicified, but are almost always difficult to extract. At the base, zone  $2_a$ ; the *Malocystites murchisoni* zone, is well developed, and as the fossils weather out in this locality, some 40 species have been listed.

While the rocks of this division usually afford poor collections, yet in favorable localities they are found to be extremely rich in interesting species. Thus, one locality on the east side of the island has yielded 60 species of fossils, among them such rare trilobites as *Asaphus marginalis*, *Isotelus ? bearsi*, and *Remopleurides canadensis*, and many species of pelecypods.

*Division 3.*—This is especially well developed on Valcour Island. Zone 3<sub>a</sub> is exposed in two or three localities on the east side. Zone 3<sub>b</sub> is best developed about Cystid Point, the southeast point of Valcour Island, and zone 3<sub>c</sub> is exposed both east and west of Black River Point on the north end. The division is 172 feet in thickness and carries *Camarotoechia plena* throughout. The faunules given for zones 3<sub>a</sub>, 3<sub>b</sub>, and 3<sub>c</sub>, are those found on Valcour Island.

*Crown Point Section.\**

The section at Crown Point is 305 feet in thickness. At the base is a zone 25 feet thick in which the strata are sandstone and shale, and the only fossil is *Lingula brainerdi*. The remaining 280 feet are impure blue and grey limestone, usually very fossiliferous. Division 1 is absent.

*Division 2.*—The fauna characteristic of this division is found all through the section at Crown Point. The characteristic fossils—*Maclurites magna*, *Rafinesquina champlainensis*, *Plesiomys platys*, and *Leperditia limatula*—are very abundant, and the whole expression of the fauna is that of the middle part of the section at Valcour Island and elsewhere. Brainerd and Seely assign the lower 48 feet to their Division A, and the upper 57 feet to Division C, but faunally the whole section belongs together. *Camarotoechia plena* is absent, as are also the other fossils characteristic of Division 3. The upper 3 feet of the section are a coarse limy sandstone, with *Plesiomys platys*, *Camarella varians*, *Raphistoma staminum*, and *Isotelus harrisi* in a layer a foot thick at the top.

*Orwell, Vermont.*

A short distance northeast of Orwell village is the most southern exposure of the Chazy. At that place there are about 60 feet of strata, the fauna of which indicates that they belong to Division 2. Another locality near by shows sandstone and shale at the base of the formation.

North of the International Boundary the various divisions can not be followed in the published lists, but this is due to the fact that no sections have been made in that region. The lists published by Billings, Logan, and Ami, of the Canadian Survey, however, do show that fossils characteristic of all three divisions are found in that region. The Champlain Valley fauna of the Chazy, which will be designated as the typical one, is found as far north as Joliette, 35 miles north of Montreal and

\* For detailed description of this section, see Bull. Amer. Pal., vol. iii, No. 14, 1902.

85 miles north of Chazy. To the west it is found as far as Hawkesbury, 75 miles northwest of Chazy and 55 miles west of Montreal.

#### MINGAN ISLANDS REGION.

The fauna of the Chazy at Mingan Islands is very closely related to that of the typical Chazy of the Champlain Valley, as is shown by the following list of species common to the two regions:—

<i>Bolboporites americanus.</i>	<i>Orthoceras bilineatum.</i>
<i>Phylloporina incepta.</i>	<i>O. multicameratum.</i>
<i>Columnaria ? ? parva.</i>	<i>Pleisoceras jason.</i>
<i>Rafinesquina incrassata.</i>	<i>Pliomerops canadensis.</i>
<i>Camarotæchia orientalis.</i>	<i>Ilænus globosus.</i>
<i>Camarella longirostris.</i>	<i>Eoharpes antiquatus.</i>
<i>C. varians.</i>	

#### OTTAWA VALLEY REGION.

The Chazy deposits of this region have been described in detail by Logan,\* Ells,† and Ami.‡ The formation is not more than 200 feet in thickness, usually less, and is divided into two parts, the lower including shales and sandstones, and the upper, limestones. It outcrops in a narrow belt extending along the north and south sides of the Ottawa River, from Hawkesbury west to Arnprior, and is again exposed south of Ottawa, whence another narrow belt runs to Cornwall, where it again turns northward. West of Arnprior there are a few outliers of the same formation. One large one occurs at Allumette Island, north of Pembroke, and another 10 or 15 miles south of this and west of Renfrew.

The coarse character of the sediments at the base of the formation in this region points to very shallow water and shore conditions and a probable erosion interval between the end of Beekmantown time and the deposition of the strata of Chazy age.

The writer has studied the rocks of this area chiefly in the vicinity of Ottawa and Aylmer, and the fauna there represented seems to consist of about 25 species, only 7 of which occur in typical Chazy deposits. The fauna of the sandstone at the Aylmer region is quite different from that found in the overlying limestone, and for that reason a list is here given of the species found in each. An asterisk denotes that the species is found also in the typical Chazy:—

\* Geology of Canada, 1863.

† Rept. Geol. Survey of Canada, 1899.

‡ Ibidem; also Trans. Roy. Soc. Canada, vol. ii, 1896, vol. vi, 1900, and various other papers.

Sandstone.	Limestone.
<i>Lingula lyelli.</i>	<i>Lingula lyelli.</i>
* <i>Camarotoechia plena.</i>	* <i>Camarotoechia plena.</i>
* <i>C. orientalis.</i>	* <i>Rafinesquina alternata.</i>
<i>Hebertella imperator.</i>	
<i>Modiolopsis breviuscula.</i>	<i>Modiolopsis breviuscula.</i>
<i>M. parviuscula.</i>	<i>M. parviuscula.</i>
<i>M. soweri</i> sp. nov.	
<i>Ctenodonta parvidens</i> sp. nov.	
<i>Whitella canadensis</i> sp. nov.	
* <i>Archinacella?</i> <i>deformata.</i>	
* <i>Raphistoma striatum.</i>	
* <i>R. stamineum.</i>	<i>Raphistoma stamineum.</i>
<i>Lophospira billingsi</i> sp. nov.	<i>Orthoceras allumettensis.</i>
<i>Bathyurus angelini.</i>	<i>Bathyurus angelini.</i>
<i>Beyrichia clavigera.</i>	<i>Leperditia amygdalina.</i>
<i>B. clavigera clavifracta.</i>	* <i>L. canadensis.</i>
	<i>Leperditella labellosa.</i>
<i>Primitia</i> sp.	<i>Isochilina ottawa.</i>
<i>Isochilina</i> sp.	<i>I. amiana.</i>
	<i>Primitia logani.</i>

It may be seen from the above parallel lists that there are only 6 species common to the sandstone and limestone divisions of this formation. In the limestones the ostracods are exceedingly abundant, often making up entire layers of the rock. The two divisions are intimately connected by very well-defined species, however, and none of the forms pass on into the overlying Lowville limestone.

In the Ottawa Valley, the most noticeable feature of the faunas is the absence of the cystids, Bryozoa, and Hydrozoa so common in the typical Chazy. The large number of species of ostracods and their great abundance are in marked contrast to the three or four species found in the Champlain Valley. This difference in the lithology and fauna has led the writer to suggest the name *Aylmer*\* formation for these deposits in the Ottawa Valley.

#### SUMMARY ON THE LAKE CHAMPLAIN, MINGAN ISLANDS AND OTTAWA VALLEY REGIONS.

In the Lake Champlain region occurs the fullest development of both the strata and the fauna of the Chazy period, and three divisions based upon faunal differences may be recognized. The fauna of the Chazy at Mingan Islands, while only partly known, shows that the typical Chazy is also found in that region. West of Hawkesbury, Canada, a decided change

\* Ann. Carnegie Mus., vol. iii, p. 380, 1905.



in the fauna is seen at L'Orignal, only 16 miles from Hawkesbury. Here is found a section less than 200 feet in thickness, with sandstone at the base and limestone in the upper portion. The fauna changes abruptly, several species occurring there which are unknown further east. The typical Chazy fossils found here are: *Camarotoechia plena*, *Raphistoma stamineum*, and *Malocystites murchisoni*. From this locality west to Allumette Island, a distance of 115 miles, the same succession of strata may be found, and about the same fauna. All through the Ottawa Valley the Chazy is represented by a formation which is sandstone at the base and limestone above. In its most western exposures, the limestones are absent and only the sandstone remains.

The base of the Chazy is always a sandstone, but this does not carry the same fauna in all regions, nor does the zone which rests upon it always have the same fauna. In the Lake Champlain region, the sandstone always contains *Lingula brainerdi*; in the Ottawa Valley, it carries a modified *Camarotoechia plena* fauna. At the type sections, *Lingula brainerdi* is at the base of the formation, while the *Camarotoechia plena* fauna appears 700 feet above.

Since the fullest development of limestone deposits of this age is in the region of Chazy and Valcour Island, New York, that must be the locality in which the Chazy sea persisted longest. From the evidence outlined above, it would seem that this sea was a shallow one, invading south and west over a slowly sinking land. Since the Chazy fauna is apparently developed less directly from the Beekmantown of the Lake Champlain area than from that of Newfoundland, and since there are many European types introduced into the Chazy, it seems probable that this sea was open to the east.

If the sea were thus invading upon the land, the sandstone would represent shore conditions. This is undoubtedly the case, for the sandstone in both the Champlain and Ottawa valleys frequently presents evidences of shore origin in cross bedding, ripple marks, and worm burrows.

If the sea were invading southward in the region now occupied by the Champlain Valley, the sandstone should be younger and younger in age as it is traced from north to south. That this is actually the case is shown by the faunas, for at Valcour Island all the strata of the *Hebertella exfoliata* division, 300 feet in thickness, were deposited before the *Maclurites magna* fauna became prominent, while at Crown Point this second fauna follows immediately upon the basal sandstone.

During the greater part of Chazy time, the transgression is southward, but later the shore began to move westward also. The region of the Ottawa Valley was then invaded, and the

sandstone brought with it a part of the *Camarotoechia plena* fauna. The date of this invasion to the west can be rather closely approximated. *Camarotoechia plena*, *Raphistoma stamineum*, and *Malocystites murchisoni* are found in the middle of the section at L'Original. At Valcour Island these species occur together in zone A<sub>39</sub>, 775 feet above the base, thus showing that the formation in the Ottawa Valley represents the very latest part of Chazy time.

Ulrich and Schuchert, in their paper on Paleozoic Seas and Barriers,\* bring out this idea of a Chazy sea invading westward and southward. They state: "With the earlier part of this subsidence [the Chazy invasion], the Atlantic invaded the continent westward. . . . The typical Chazy formation . . . bears evidence in its members of having encroached southward and westward in the arms, the latest beds . . . extending farthest south and west."

#### THE CLOSING PERIOD OF CHAZY TIME.

In the preceding pages an effort has been made to show that in northeastern New York and in the Ottawa Valley, the Chazy sea invaded over a land surface of Beekmantown rocks, and that the base of the Chazy is a tangential sandstone; also that the invasion was first southward, covering the region of the Champlain Valley, and later westward along the locality of the present Ottawa Valley.†

Of the former extent of the formation throughout the St. Lawrence Valley or elsewhere, there is at present little evidence. Since the sea did not attain the region of Aylmer until very late Chazy time, it is probable that the formation never extended much further west than the known outcrops in that region (Allumette Island, etc.).

From a study of the stratigraphy and faunas it becomes evident that the upper portion of the Chazy is not represented in the region south of Valcour Island. Either these beds were never deposited there or they were eroded before the Lowville was laid down. The evidence is not of such a character as to prove definitely which did occur, but for reasons given below it seems more probable that the upper beds were deposited south of Valcour and later eroded. These reasons are as follows:—

\* Rept. N. Y. State Pal., 1902, p. 639.

[† By these terms, Champlain Valley and Ottawa Valley, the writer does not intend to convey the impression that the Chazy deposits were laid down in narrow arms of the sea, or that the topography was then anything like that of the present time. It should be remembered that strata of post-Chazy age are involved in the Green Mountain uplift, and that there are indications that the Adirondacks did not exist in Ordovician time.]

*First.* All through the Champlain Valley, the Chazy is capped by a bed of sandstone 2 feet in thickness, and this may be interpreted as the invading base of the Lowville formation. From this it would follow that a period of erosion existed between the Chazy and Lowville formations.

*Second.* If the upper beds were never deposited south of Valcour, the Chazy sea after advancing slowly to the south to some point below Orwell, Vermont, must have then retreated to the northward. Such a recedence could have been caused only by an elevation south of Orwell, for there is no general retreat of the Chazy sea at this time, which is proved by the fact that at a still later period the sea advanced westward beyond Ottawa. That there was then no uplift in the south is shown by the fact that the Lowville sea invades from the southwest.\* On the other hypothesis, which seems more probable, the sea would have invaded southward to the region of Orwell and after depositing there the final, or *Camarotoechia plena*, beds vanished from the area of Lake Champlain. During the latter part of Chazy time or after its close, the Stones River (Lowville) sea was invading from south to north and there was a land interval in the Champlain region, during which time some of the Chazy and Beekmantown beds were removed along the barrier region between Orwell and the Mohawk Valley.

*Third.* By taking the rate of decrease in thickness (11.25 feet per mile) of the *Hebertella exfoliata* division between Chazy and Valcour Island, to compute the probable southern extent of that division, it is seen that it would have reached only 26.6 miles south from Valcour Island. Therefore, at the same rate of decrease the base of the Crown Point section is 461 feet higher than the base of the Valcour Island section. That this rate of decrease can not be used, is shown by the fact that Division 1 at Isle La Motte is only 225 feet thick, which is less than at Valcour Island, while Isle La Motte is as far north as is Chazy. The only reliable data for an estimate of this character are the facts that there are 300 feet of the beds of Division 1 at Valcour Island and nothing at Crown Point. This is a thinning out of 7.3 feet per mile, which, on the other hand, is probably too small. On this basis, the bottom of the Crown Point section is at least 300 feet above the base of the Valcour Island section and the base of the Orwell section is at least 424 feet above it. If this minimum estimate of the height of the base of the Crown Point section above that of the Valcour Island section is accepted as a working basis, it will be seen that the former lacks the upper 285 feet of the formation. This is a gradient of 6.95 feet per mile

\* See Ulrich and Schuchert.

to the top of the beds at Valcour Island. Taking the base of the Orwell section at 424 feet, the upper 407 feet are lacking. The thinning in the 17 miles from Crown Point to Orwell is 122 feet, or 7.1 feet per mile, while the gradient to the top of the Chazy at Valcour Island is 7.01 feet per mile. The close correspondence of these gradients and the small gradient of 7 feet per mile for 58 miles are significant, and seemingly indicate a base-leveled surface of this land during the Chazy-Lowville interval.

#### REPRESENTATION OF CHAZY TIME IN OTHER REGIONS.

The Chazy was formerly identified by various geologists as covering a large area, but more recently it has been held that while certain formations may have been laid down during Chazy time, the typical rocks and fossils of this period are restricted to the region of the Champlain and Ottawa valleys and the islands in the Gulf of St. Lawrence.

#### *The St. Peter's Sandstone.*

One of the formations which has long been correlated in time with the Chazy is the St. Peter's sandstone, which in Iowa, Minnesota, and parts of Illinois underlies the lowest member of the Mohawkian series. The fauna\* of this formation is meagre and is contained in a few layers near the top. It is made up chiefly of Mollusca, all closely allied to Trenton forms. None of the species are found in the Chazy; hence no new light is thrown on the correlation by the later studies of the Chazy fauna. On lithological grounds, James has correlated it with the Chazy of the Ottawa Valley, but there are no species common to the two formations. From the close relationship of its fauna to that of the Mohawkian (Trenton) it seems probable that the St. Peter's was deposited during Stones River time.

#### *Stones River Group.*

In the Columbia, Tennessee, folio of the U. S. Geologic Atlas, Ulrich has stated that the lower part of the Stones River group, including the Lebanon, Ridley, Pierce, and Murfreesboro limestones, is to be correlated in time with the Chazy of New York State.

This statement is evidently based mainly on stratigraphic grounds, as Ulrich and Schuchert† have held that the Low-

\* F. W. Sardeson, Bull. Minnesota Acad. Sci., vol. iv, No. 1, pt. 1, p. 64, 1896.

† Paleozoic Seas and Barriers, Rept. N. Y. State Pal.; Bull. 52, N. Y. State Mus., 1902, p. 633.

ville of New York is the northeastern representative of "the extreme top of the Stones River" group.

In the Columbia folio referred to above, Ulrich has tabulated the fossils of all the divisions of the Stones River group as developed in the middle Tennessee region. In the Lebanon formation, the upper member of the Stones River group which is there correlated with the Chazy, there are, according to the table, 37 species besides 10 undescribed Bryozoa. Of these 37 species, 7 are Bryozoa and 5 are not specifically identified. This large number of Bryozoa—17 species—at once suggests that the formation containing them is much more closely allied to the Trenton than to the Chazy. Leaving out of account the Bryozoa, which in the Ordovician nearly always have a very restricted vertical range, and the 5 forms not specifically identified, it is found that 17 of the 25 species remaining are Black River or Trenton forms. All the brachiopods, 4 of the 5 gastropods, and 2 of the 3 trilobites are species occurring in higher formations. Even if all the described species are included, 53 per cent of the species of the Lebanon formation are Black River or Trenton forms.

Below the Lebanon is the Ridley horizon, about 80 feet in thickness. Of the 9 species listed from this formation, 6 are found in the Black River.

Below the Ridley is the Pierce limestone with 12 species listed and 20 undescribed bryozoans. Only 11 forms are specifically identified and of these 30 per cent are Black River or Trenton forms.

The lowest member of the Stones River group is the Murfreesboro, which is about 60 feet in thickness and contains 24 species, 21 of which are identified. The fauna is composed principally of Mollusca, of which gastropods of the genera *Lophospira* and *Liospira* are particularly numerous. Of the 21 species, 11 are Black River or Trenton forms, so that 52 per cent of the species in this oldest member of the Stones River group belong to the Black River or Trenton.

This analysis may be tabulated thus:—

	Lebanon.	Rid- ley.	Pierce.	Murfrees- boro.	Black River.	Tren- ton.
Lebanon .....	25	--	1	--	4	7
Ridley .....	1	3	--	--	1	1
Pierce .....	4	2	9	1	1	2
Murfreesboro.....	3	4	1	21	4	7

Of the 58 described species occurring in these 4 subdivisions of the Stones River, the above table shows that 27, that is, 46 per cent, occur in the Black River and Trenton formations.

Comparing the large percentage of forms common to the Stones River and to the Black River and Trenton with the low percentage—less than 5 per cent—of forms common to the Chazy and Trenton, it becomes evident that the Stones River and Trenton are faunally much more closely connected than are the Chazy and Trenton. This close relationship of the fauna of the Stones River to that of the Trenton, coupled with the stratigraphy, suggests that the whole Stones River is younger than the Chazy.

*East Tennessee.*

In east Tennessee the Maclurea limestone was correlated by Safford\* with the Chazy or Black River of New York and Canada. While a large part of this limestone seems to be of Trenton age, a section around Lenoirs has afforded the writer a small fauna containing fossils characteristic of Division 2 in the Lake Champlain region. This region needs further study before definite correlations are made.

DESCRIPTION OF NEW SPECIES.

BRACHIOPODA.

*Lingula columba* sp. nov.

Shell small, oval in outline, gently and uniformly convex. There are no flat slopes and the front is semi-circular in outline. The posterior end is somewhat triangular, the beaks pointed. The surface is covered by very numerous and prominent concentric striæ, no radiating lines showing except when the surface is exfoliated.

One specimen is 10<sup>mm</sup> long and 7<sup>mm</sup> wide; another is 7<sup>mm</sup> long and 5<sup>mm</sup> wide.

*Locality.*—East side of Valcour Island at Chazy, and on Isle La Motte. Type in Yale University Museum.

*Camarotechia pristina* sp. nov.

Shells small, transversely oval to subcircular in outline. Both valves moderately and uniformly convex. The dorsal valve has a low fold and the ventral valve a shallow sinus, which is noticeable only toward the front of the shell. There are 10 to 14 strong rounded plications, 4 on the dorsal fold and 3 on the sinus. The 2 plications in the middle of the fold are smaller than the 2 outside ones and the median plication of the ventral valve is the weakest, which is the direct opposite of the state found in *Camarotechia orientalis*.

*Locality.*—Valcour Island and Chazy, New York. The type is in the Carnegie Museum.

\* Geol. Tennessee, 1869, p. 236.

*Camarotoëchia major* sp. nov.

Outline somewhat oval, widest a little in front of the middle. Dorsal valve with 10 to 14 strong angular plications. The ventral valve has 9 to 14. The fold and sinus are hardly defined except by a gentle arch in front, but are outlined on both valves by a pair of very strong plications. The dorsal fold bears 5 plications, the middle one of which is the strongest. The ventral sinus has 4 plications, the 2 largest in the middle. The ventral beak is somewhat incurved.

Length of a good specimen 23<sup>mm</sup>; width 21<sup>mm</sup>.

*Locality*.—Southeast point of Valcour Island, New York. The type is in the writer's collection.

*Strophomena prisca* sp. nov.

Shell of medium size, resupinate, nearly as long as wide. Ventral valve convex at the umbo, flat in front to about the middle of the valve and then concave. Dorsal valve flat on the umbo and convex in front. Cardinal area narrow, the wide delthyrium mostly covered by the deltidium, with a small opening for the pedicle at the beak. Muscle area in the ventral valve small, confined to the space under the umbo. Surface marked by fine alternating striæ, the prominent ones being very numerous and increasing by implantation. Between each pair of the strong striæ are two or three finer ones and the whole surface is crenulated by fine concentric striæ. The dorsal valve sometimes shows very small concentric wrinkles.

One specimen is 15.5<sup>mm</sup> long and 20<sup>mm</sup> wide; another 16<sup>mm</sup> long and 19.5<sup>mm</sup> wide.

*Locality*.—All the specimens are from Valcour Island, New York, and are in the writer's collection.

*Orthis ignicula* sp. nov.

Shell transversely oval in outline, usually but little wider than long. Hinge width nearly equal to the greatest width of the shell. Ventral valve strongly convex, the area high and a little incurved.

Dorsal valve nearly flat, with a broad depression near the front. Area of dorsal valve rather wide. Cardinal process small. Delthyrium narrow and open. Surface marked by 16 to 25 direct rounded plications which increase by implantation.

*Locality*.—Found rarely on the southeast corner of Valcour Island, New York.

*Orthis acutiplicata* sp. nov.

Shell small, almost circular in outline. Hinge width not quite equal to the greatest width below. Cardinal area of ventral valve high and a little retrorse. Foramen narrow and open. Ventral valve strongly convex, highest on the umbo. Dorsal valve convex on the umbo, flattened in front. There is a shallow sinus on this valve, which is narrow at the beak but becomes wider in front. Surface marked by 12 to 15 sharp simple striæ separated by spaces wider than the striæ.

*Locality.*—South end of Valcour Island. The types are in the writer's collection.

*Plasiomys strophomenoides* sp. nov.

Shell small, ventral valve convex at the umbo, concave in front. Dorsal valve convex, with a narrow sinus on the umbo, but frequently with a slight fold on the front of the shell, in which case the ventral valve shows a shallow median sinus.

Surface marked by numerous fine striæ, which increase by bifurcation and implantation. There are usually 7 or 8 in the space of 2 millimeters on the middle of the front of the shell.

The cardinal area of both valves is low. The ventral area has a narrow delthyrium, which at the apex is perforated for the passage of the pedicle. The interior of the ventral valve shows small but strongly marked muscle scars under the umbo. The muscle area is roughly quadrate and contains a pair of strong diductor scars, between which are the narrow adductor attachments. Posterior to the latter is a deep pedicle scar. The lateral edges of the diductor scars are bounded by strong plates, which run back to support the dental lamellæ. The interior of the dorsal valve shows a robust, simple cardinal process and small dental sockets bordered by strong plates which do not greatly diverge. In front of the cardinal process is a low but strong median ridge, on either side of which are the four scars of the adductor, not, however, deeply impressed.

*Locality.*—Crown Point, Plattsburg, and Valcour Island, New York. The type is from the quarries near the Plattsburg Fair Grounds and is in the Carnegie Museum.

*Hebertella exfoliata* sp. nov.

This shell is distinguished from *Hebertella costalis* by its smaller size, more pronounced dorsal sinus, and by the fact that the striæ are always simple instead of bifurcating. It differs from *H. borealis* in its smaller size, and in the narrow and deep dorsal sinus.

*Locality.*—Common in the lower part of the Chazy at Chazy and Valcour Island; also at Plattsburg, Valcour, and Isle La Motte, New York. The type is in the Carnegie Museum.



*Orthidium lamellosa* sp. nov.

Ventral valve strongly convex, the area high and curved backward. Delthyrium narrow and open. Along the middle of the valve is a narrow and shallow depression in which there is one plication. The outline of the shell is subquadrate. The greatest length is at the hinge and the cardinal extremities are slightly alate.

The dorsal valve has a narrow median sinus, which extends from the beak to the front and usually contains 2 plications. There are commonly about 20 sharp plications, which are crossed by strong concentric lamellæ of growth.

An average specimen is 3<sup>mm</sup> long and 5.5<sup>mm</sup> wide.

*Locality*.—Valcour Island, Chazy, and Crown Point, New York. The types are in the Yale University Museum.

PELECYPODA.

*Ctenodonta peracuta* sp. nov.

Shell small, longer than high, the beak about one-third the length from the posterior margin. Front rather drawn out, as in *Ctenodonta nasuta* Hall. The greatest convexity is at the umbo, the posterior slope very gradual. Both slopes to the hinge abrupt, but that to the basal margin gentle. One specimen is 12<sup>mm</sup> long and 9<sup>mm</sup> high. This species may be distinguished from the succeeding one by its more depressed valves and by the prolongation of the anterior margin into a somewhat nasute extension.

*Locality*.—Found in some numbers in the trilobite layers at Sloop Bay, Valcour Island, and in the middle of the Crown Point section. The type is in the writer's collection.

*Ctenodonta limbata* sp. nov.

Outline nearly circular, the beak back of the middle. Greatest convexity near the middle of the valve; all slopes steep. The cast shows a few faint lines of growth.

Length of largest specimen 10<sup>mm</sup>; height 10<sup>mm</sup>. A smaller one measures 8 x 8<sup>mm</sup>.

*Locality*.—All the specimens are from the trilobite layers, Sloop Bay, Valcour Island. The types are in the Yale University Museum.

*Ctenodonta dubiaformis* sp. nov.

Shell small, moderately convex, beak subcentral. Greatest convexity on the umbo, the slope from it to the base nearly flat. Basal margin nearly straight. Anterior end nasute and

longer than the posterior, which is regularly rounded. Front margin rather acute. All the specimens are of casts without trace of hinge teeth, muscle scars, or surface markings.

Largest specimen: Length 19<sup>mm</sup>; height 10·5<sup>mm</sup>. Another: Length 17<sup>mm</sup>; height 9<sup>mm</sup>.

*Locality.*—Sloop Bay, Valcour Island. The type is in the Yale University Museum.

*Otenodonta parvidens* sp. nov.

Shell oval in outline, usually flattened, but specimens from the harder layers show considerable convexity below the umbo, with regular slopes to the anterior, posterior, and ventral margins. The cast shows the impression of numerous very fine teeth on the hinge, but the number can not be counted as the beak is always flattened down upon the impression of the hinge. One specimen exhibits 5 teeth on the anterior portion of the hinge. Another shows 7. The surface is marked by very numerous fine concentric lines of growth.

*Locality.*—In shales and limy clays at the Hog's Back, Ottawa.

*Clidophorus obscurus* sp. nov.

Shell small, longer than high, not very convex. Basal margin nearly straight, anterior margin regularly curved, posterior end compressed, the margin acutely rounded. In front of the beak the cast shows a short clavicular impression, which extends about half the distance to the lower margin.

Length 6<sup>mm</sup>; height 4<sup>mm</sup>.

*Locality.*—Trilobite layers, Sloop Bay, Valcour Island. The type is in the Yale collection.

*Cyrtodonta tranceps* sp. nov.

Shell roughly rectangular in outline, strongly convex at the umbo and along a ridge which runs diagonally across the shell to the lower side of the posterior margin. In front of this ridge there is usually a slight depression running from the umbo to the middle of the lower side. The posterior margin is regularly rounded, the lower side straight or slightly indented. The anterior end extends a short distance in front of the beak. The slope to the hinge is flat and rather steep. The slope to the front and base is gently convex and more gradual. The surface is marked by numerous concentric lines.

*Locality.*—Valcour Island, New York. The type is in the collection of the Carnegie Museum.

*Cyrtodonta solitaria* sp. nov.

Shell roughly triangular, the beak a little behind the anterior end. Hinge line short. The anterior margin is narrow and rounded, the base long and straight, incurved at about 45° with the hinge. Posterior regularly rounded. Shell only moderately convex, the slope to the posterior end gradual and to the front nearly flat.

Length 15<sup>mm</sup>; height 12·5<sup>mm</sup>. Surface marked by concentric lines of growth.

*Locality*.—Ledge in pasture near Tracy Brook, Chazy, New York. The type is in the Yale collection.

*Whitella canadensis* sp. nov.

Shell small, convex, subrectangular in outline. A prominent ridge extends from the beak to the lower posterior corner. From this ridge the slope to the cardinal and posterior margins is abrupt, while there is little slope to the front until a point in front of the beak is reached, when the slope is suddenly deflected. The surface is marked by concentric undulations.

*Locality*.—Aylmer sandstone, Aylmer, Quebec.

*Clionychia marginalis* sp. nov.

Both valves moderately convex, the umbones somewhat depressed, but increasing rapidly in height, the greatest thickness of the valves being at about one-third the distance from the beak to the lower margin. Hinge line short. The posterior margin is broadly rounded, the lower margin semi-circular. The front is almost straight. The greatest convexity is along a line parallel to the front. The posterior and lower slopes are gentle, but the front slope is abrupt, almost 90° with the plane of union of the valves. The surface is marked by very fine concentric striæ.

One specimen is 20<sup>mm</sup> long and 26·5<sup>mm</sup> high.

*Locality*.—Chazy and Valcour Island, New York. The type is in the Yale collection.

*Ambonychia? curvata* sp. nov.

Shell large, both valves very strongly convex, especially along the region of the front and middle of the valves. Beaks small, incurved, directed a little forward. Anterior slope abrupt and overhanging. Posterior and bottom slopes rather steep. Posterior wing short. The posterior margin is almost straight. The anterior margin is regularly curved. The length and breadth are nearly equal.

A large specimen is 27<sup>mm</sup> long and 26<sup>mm</sup> high. Another is 43<sup>mm</sup> long and 39<sup>mm</sup> high. A small one is 10<sup>mm</sup> long and 10<sup>mm</sup> high.

The species is easily recognized by the curved anterior margin and the great convexity. The line of greatest convexity follows the anterior margin. There is an elongate posterior muscle faintly outlined on some of the casts. The general appearance is somewhat like *Ambonychia amygdalina* Hall.

*Locality*.—Valcour Island, Chazy, and Sloop Island, New York.

*Conocardium beecheri* sp. nov.

Shell very small but robust, with long anterior and short posterior wings. The region of greatest convexity is from the beak straight to the base of the shell, the curvature decreasing gradually forward to the anterior wing and rather abruptly backward to the posterior wing. The anterior wing is long, with straight lower margin. The posterior wing is short and narrow, joining the body at a large angle. The surface is marked by 7 or 8 large plications on the anterior wing, 15 or 20 smaller ones on the body of the shell, and 3 or 4 very large ones on the posterior wing. The dimensions of 2 specimens are: First, length 6.5<sup>mm</sup>, height 5<sup>mm</sup>; second, length 6<sup>mm</sup>, height 4<sup>mm</sup>.

*Locality*.—Sloop Island, east of Valcour Island, New York; also on Valcour Island and at Chazy, Clinton County, New York.

*Modiolopsis fabaformis* sp. nov.

Shell small, thick, with a strong ridge extending from the umbo to the lower posterior angle. In front of this ridge is a deep depression, which continues to the middle of the ventral margin; making that margin sinuate. Anterior ear small, convex. Anterior margin narrowly rounded. Posterior margin broadly rounded, not oblique as in *Modiolopsis breviscula* and *M. parviuscula*. The surface is marked by numerous concentric lines of growth.

*Locality*.—Common in the upper layers at Valcour Island. The type specimen is in the writer's collection.

*Modiolopsis sowteri* sp. nov.

Shell of medium size for the genus, rather convex, with a strong ridge running back from the beak to the lower posterior angle. Toward the front is a slight depression running from just ahead of the beaks a little backward to the basal margin. In front of the beak is a very deeply impressed anterior scar,

which on the internal cast is represented by a rounded conical elevation. The posterior scar is large and close to the hinge line.

Length 51<sup>mm</sup>, height 28<sup>mm</sup>.

Length 37<sup>mm</sup>, height 20<sup>mm</sup>.

*Locality*.—From the Aylmer sandstone, about 60 feet above the high-water mark of Lake Deschenes, at Aylmer, Quebec. Collected by T. W. E. Sowter, for whom it is named. The type is in the Yale University Museum.

GASTROPODA.

*Archinacella*? *deformata* (Hall).

*Orbicula*? *deformata* Hall, 1847, Pal. N. Y., vol. i, p. 23, pl. iv bis, figs. 10a, 10b.

*Metoptoma*? *dubia* Hall, *ibid.*, figs. 11a, 11b.

*Stenotheca dubia* Whitfield and Hovey, 1898, Catalogue of Type and Figured Specimens in the American Museum of Natural History, Bull. Amer. Mus. Nat. Hist., vol. xi, p. 58.

An examination of the types shows that Whitfield was right in regarding the specimen named *Orbicula*? *deformata* by Hall as identical with *Metoptoma*? *dubia*, which Hall described on the same page. His species, however, must take the first specific name applied to it, even though given under the misapprehension that it was a brachiopod instead of a gastropod.

The generic reference is uncertain as no specimens have been found which show either muscle scars or pronounced surface markings. It does not seem possible to leave it either in the genus *Metoptoma*, where Hall doubtfully put it, or in *Stenotheca*, where it was placed by Whitfield. In general form it most resembles the numerous species of *Archinacella* described by Ulrich and Scofield, to which it may be referred until better examples are obtained. The individual specimens of this shell are abundant and the characters are quite constant. It is easily recognized by the low form and almost marginal position of the beak.

*Scenella pretensa* sp. nov.

Shell small, aperture narrowly elliptical in outline. Height about equal to the greatest diameter of the aperture. Beak small, pointed backward, but not incurved. Posterior slope nearly straight. Anterior slope convex above, becoming straight below. Surface smooth, except for a few low concentric undulations near the base. Beak a little behind the middle.

The greatest diameter is 11<sup>mm</sup>; the shortest is 6.5<sup>mm</sup>. Height 11.5<sup>mm</sup>.

*Locality.*—Rare at Chazy, New York, in the Lower Chazy layers south of the lime kilns. It occurs also at Lenoirs, Tennessee.

*Scenella robusta* sp. nov.

Shell large, aperture nearly circular. Beak obtuse, rather high, and located a little behind the middle. All slopes about equal and all convex, the whole shell somewhat hemispheric. The specimens are all casts, showing no surface markings of any sort.

The only perfect example is 17<sup>mm</sup> in greater diameter and 16<sup>mm</sup> in lesser. A much larger one is represented by a fragment 27<sup>mm</sup> long, but it had evidently been considerably larger.

*Locality.*—Valcour Island, in the Middle Chazy beds. Rare. The type is in the writer's collection.

*Palæacmæa irregularis* sp. nov.

Shell rather large, irregular in outline, generally subcircular, but never with a smooth curve. Beak obtuse, almost central, sometimes a little back of the center. All slopes about equal, generally almost straight, but occasionally a little convex. Surface marked by numerous fine concentric lines of growth, which follow the irregular form of the aperture. Usually there are a few radial folds and some irregular depressions and pits which do not follow in symmetrical arrangement.

The greater diameter of the aperture is 26<sup>mm</sup>; the lesser is 10<sup>mm</sup>. The aperture of another is 19<sup>mm</sup> long, 18<sup>mm</sup> wide, and the apex is 9<sup>mm</sup> above the aperture.

*Locality.*—Common in lower layers at Chazy, New York.

*Helicotoma vagrans* sp. nov.

Shell small, somewhat *Maclurea*-like, the spire flat and depressed below the plane of the highest points on the upper surface. Outer edge of the body whorl angular, raised as a high sharp ridge toward the aperture. Lower surface of the shell rounded, the umbilicus wide. Aperture large, quadrilateral, angular above, rounded below. Surface marked by fine lines of growth, which turn back on crossing the angle of the upper surface.

*Locality.*—A rare fossil at Valcour Island, New York. The type is in the writer's collection.

*Eotomaria obsoletum* sp. nov.

Shell small, trochiform, with about four volutions. The upper part is conical, the volutions are flat, and the sutures only

slightly impressed. The lower surface is convex, umbilicus small. The present specimen is a cast and shows no surface markings. Aperture large, angulated on the side, rounded below.

*Locality*.—Crown Point and Valcour Island, New York. Very rare. The type is in the writer's collection.

*Lophospira rectangularis* sp. nov.

Shell fairly large, with 5 volutions. Body whorl very large, spire small. Last 3 whorls with sides parallel to the axis of the shell. Aperture large, nearly circular. Upper lip nearly straight, meeting the straight outer lip at an obtuse angle. The inner and lower sides of the aperture are rounded. The umbilicus is very small.

All the specimens in the collection are casts of the interior and do not show anything more than traces of the surface markings. They were probably the same as in *Lophospira subabbreviata*.

*Locality*.—A rare species from Valcour Island, New York. The type is in the writer's collection.

*Lophospira billingsi* sp. nov.

Shell of 4 volutions, body whorl very large, spire low, whorls angular, sloping gently from the suture to the keel. The under side of the body whorl is rounded and strongly convex. The umbilicus is small. The aperture is entire, the inner and lower lips are rounded, the upper lip is straight from the suture to the keel, sharply angulated at the keel and nearly straight for a short distance below it. The surface is covered by rather coarse lines of growth, which run first forward and cross the upper side of the volution diagonally and backward, again turning forward after crossing the volution. On the under surface of the whorl, the striæ turn back to the umbilicus.

*Locality*.—From the Canadian Pacific Railroad cut, east of Main street, Aylmer, Canada. Named for W. R. Billings of Ottawa, an enthusiastic student of the Chazy.

*Cyclonema? normaliana* sp. nov.

Shell small, elongate trochiform, with 4 or 5 whorls, which enlarge gradually. Sutures not deeply impressed and volutions almost flat sided. The under surface of the last whorl is flat or slightly convex. The surface is marked by 3 or 4 revolving raised lines or low keels.

*Locality*.—Lower Chazy, near the Normal School at Plattsburg, New York.

*Eunema leptonotum* sp. nov.

Shell small, with about 4 whorls, which increase gradually toward the base. The whorls are all convex, the suture is deeply impressed. The first 3 whorls are smooth and *Holopea*-like. The fourth, or body, whorl is ornamented by 5 sharp revolving ridges, equally spaced. These ridges are crossed by fine vertical lines, which are close together and give the ridges a pitted appearance. The aperture is not seen.

The height of the shell is 5<sup>mm</sup>; the width of the body whorl 3.5<sup>mm</sup>.

This shell is not uncommon in the Chazy, but on account of its small size and liability to exfoliation it is often overlooked or is in too imperfect a condition to be positively identified.

*Locality*.—Lower Chazy, at Chazy, New York. The type is in the Yale collection.

*Trochonema dispar* sp. nov.

Shell rather large, consisting of 3 whorls with depressed spire and very large body whorl. The suture is very deep. The whorls are almost free. The body whorl has a flat revolving band on the outer side. The top is flat and sloping and the lower side strongly convex. The surface markings are not shown. The umbilicus is large in the cast, but rather small in testiferous specimens.

*Locality*.—Fairly common on Valcour Island, in a locality at the south end. It is rare elsewhere on the island and at Chazy, New York. The type is in the writer's collection.

*Subulites prolongata* sp. nov.

Shell small, elongate, fusiform, with about 6 (?) whorls (specimen shows body whorl and 3 above). The whorls are long and narrow, decreasing slowly and regularly toward the top. The body whorl is about equal to the length of the 2 whorls above it and is contracted below. The aperture is not shown.

The length of the fragment is 29<sup>mm</sup>; the greatest thickness is 5<sup>mm</sup>. Probably the total length was about 35<sup>mm</sup>.

*Locality*.—Sloop Bay, Valcour Island. The type is in the Yale collection.

*Holopea hudsoni* sp. nov.

Shell usually large, with about 4 whorls. The body whorl is large, robust, expanding rapidly. The spire is fairly long, whorls strongly convex, sutures very deep. Aperture nearly circular, entire; the outer lip thin, the inner lip free from the body whorl. The umbilicus is small.



The surface is usually smooth. Some casts show traces of lines parallel to the margin of the outer lip. These lines run a little forward from the suture, continuing in this direction over the bulge of the whorl, then curve a little backward and finally forward again at the lower end.

*Locality.*—Rather common at Crown Point, Valcour, Valcour Island, Plattsburg, and Chazy, New York. The type is in the writer's collection.

*Holopea scrutator* sp. nov.

Shell of medium size, about 3 whorls, the body whorl constituting by far the larger part of the shell. Spire depressed, sutures not deep. Aperture elongate, oval, entire. Umbilicus small.

The specimens usually occur as casts, but on a few the shell is preserved. It shows no markings except a few growth lines, which run diagonally back across the whorl. When the specimens are exfoliated the suture lines are much more deeply impressed and the spire appears higher.

This shell is easily distinguished from the preceding by the low spire, the shallowness of the sutures and the general depressed form of the shell.

*Locality.*—Common at Valcour Island and Chazy, New York. The type is in the Yale Collection.

*Conularia triangulata* sp. nov.

Shell small, slender, slightly curved, 6-sided, but 3 of the sides are so narrow as to give the shell an almost triangular cross section. The narrow faces alternate with the wide ones, the former truncating the angles which the latter would make if prolonged till they met. Along each of the faces, both wide and narrow, is an elevated line, which extends longitudinally along the center of the face. The surface markings consist of numerous fine transverse striæ, which bend backward on crossing the raised line.

The best specimen in the writer's collection is broken at the tip and at the aperture, yet is 38<sup>mm</sup> long. The original length was at least 8<sup>mm</sup> more. At the largest end the 3 wide faces are each 7<sup>mm</sup> wide and the narrow faces are each 1.5<sup>mm</sup> wide. At the small end the wide faces are 2.5<sup>mm</sup> wide and the narrow faces are reduced to practically nothing, thus showing that in young stages the shell was really triangular.

*Locality.*—The type specimen, which is in the writer's collection, was found in the upper part of the Chazy, on the southeast point of Valcour Island (Cystid Point). It also occurs near Smuggler's Bay, in layers a little lower in the formation.

## OSTRACODA.

*Leperditia limatula* sp. nov.

Length 10.5<sup>mm</sup>; height 7.5<sup>mm</sup>.

Length 9<sup>mm</sup>; height 6<sup>mm</sup>.

Length 9.5<sup>mm</sup>; height 6.25<sup>mm</sup>.

Length 9.5<sup>mm</sup>; height 7.5<sup>mm</sup>.

Shell of medium size, a little smaller than *Leperditia fabulites*, oblong in outline, higher behind than in front. Hinge short, straight. Anterior end regularly rounded. The posterior end slopes back almost straight for a short distance, but is broadly rounded on the lower posterior margin. The eye tubercle is small, on some specimens sharp, on others obscure. It is situated in the anterior angle, above and a little in front of the "muscle spot." The latter is large, circular, and very finely reticulated. Back of the muscle spot is a region of the shell which is covered with fine raised lines radiating from the side of the spot. These lines frequently anastomose, making a very pretty reticulate surface. The muscle spot is raised above the general surface of the carapace on the lower posterior side, where these lines originate, but the upper and anterior sides are level with the main part of the shell.

The right valve overlaps the left valve considerably, especially along the ventral edge, which is abruptly deflected and usually shows a low short ridge right at the keel. The lower margins of the anterior and posterior ends are flanged. The border is very narrow and is marked by small pits, which increase in size ventrally. On one finely preserved specimen the anterior flange shows 8 pits, of which the seventh, counted from the front, is largest, and the eighth is very small. On the posterior flange of the same specimen there are 10 pits, the eighth from the posterior end being the largest, the ninth a little smaller, and the tenth minute. The left valve is not so high in proportion to the length as the right valve, but it is also abruptly deflected ventrally. It shows neither anterior nor posterior flanges and there is a small projection close to the hinge line and parallel to it. Below this is a slight depression.

*Locality.*—Common on Valcour Island in certain localities. Rare at Valcour and Chazy, New York.

*Primitia latimarginata* sp. nov.

Carapace small and depressed. Front and posterior margins meet the dorsal margin at angles of little more than 90°. Both ends are broadly rounded, the ventral margin is gently curved. The shell is a little higher at the posterior end than

in front. There is a deep sulcus just in front of the middle, which starts from the dorsal margin and extends half-way down the valve, turning a little forward at the lower end. On well-preserved specimens, in front of this sulcus there is a prominent eye spot, which is sometimes translucent. Often there is another slight depression or sulcus in front of the eye spot. The border is wide, concave, and of nearly uniform width all around from the anterior angle of the dorsal margin to the posterior one. The test is frequently punctate.

*Locality.*—Common all through the Chazy limestone at Chazy, Valcour Island, Crown Point, and elsewhere in the Champlain Valley.

TRILOBITA.

*Heliomera* subgen. nov.

*Heliomera sol* (Billings).

*Cheirurus sol* Billings, 1865, Paleozoic Fossils of Canada, vol. i, p. 288, fig. 276.

Cephalon short, wide, the glabella very large and flattened, the cheeks small. Glabella almost semi-circular, with 3 pairs of long, narrow glabellar furrows, all of which turn backward on their inner ends, each joining the one back of it, and the third pair joining the neck furrow, thus producing a central lobe like that of *Amphilichas*. This central lobe is of uniform width up to the inner ends of the first pair of glabellar furrows, but turns outward in front of that point. Toward the front of this median lobe there is a slight depression, somewhat similar to that sometimes seen in *Pliomerops canadensis*. The first pair of glabellar furrows run backward at an angle of about  $45^\circ$ , the second pair at a smaller angle, while the third pair are nearly parallel to the neck furrow. The glabellar lobes are narrow and club-shaped. This radiating arrangement of the glabellar furrows and lobes probably suggested the specific name. The neck ring is wide, flat, and separated from the glabella by a deep furrow, which extends the whole width of the cephalon. The cheeks are not sufficiently well preserved to be described, but enough of the test remains to show that the outline of the cephalon was the same as in *Pseudosphærezochus vulcanus*. There is a narrow smooth border all around the front of the cephalon, and the surface is covered with fine tubercles. The relations of this species are rather doubtful. From the form of the cephalon it evidently belongs close to *Pseudosphærezochus*, but there has not been seen in species of that genus any tendency to vary in the direction of an isolated central lobe and long isolated glabellar

furrows. The glabellar furrows in the various species of *Pseudosphærexochus* are usually faint, never deeply impressed as in this species. In this last character and in the presence of the median depression of the glabella, it recalls *Pliomeros*. The glabella is much larger in proportion to the size of the cephalon in *Heliomera sol*, however, and it is probable that this form must be regarded as intermediate between the two genera. For trilobites with this type of glabellar structure the subgeneric name *Heliomera* is suggested.

*Locality.*—From the Raphistoma layers in the upper part of the Lower Chazy, at Chazy, New York. The type is in the Yale University Museum.

Paleontological Laboratory,  
Yale University Museum, June 24, 1905.

ART. XXXIX.—*The Mechanical Properties of Catgut Musical Strings*; by J. R. BENTON, PH.D.

THE experiments here described were made in connection with investigations on the stress-strain relation in elastic solids, carried out at the Geophysical Laboratory of the Carnegie Institution under the direction of Dr. G. F. Becker, to whom the writer desires to make acknowledgment for many valuable suggestions in regard to the work presented in this note. Researches on the stress-strain relation have been made for rubber and for the metals; and it was thought of interest to experiment also on a substance of intermediate properties as regards extension within the elastic limit; for this purpose, catgut, as used for strings of musical instruments, appeared to be best adapted. Owing to its hygroscopic properties and the complicated nature of the after-effects it exhibits, it was found that a precise determination of the deviations from Hooke's law would involve an amount of labor far greater than was thought to be warranted by the importance of the substance. Such results as were obtained, however, together with general data on the mechanical properties of catgut, seem of sufficient interest to justify the publication of the present note.

*Tensile Strength.*—A piece of catgut  $.061^{\text{cm}}$  in diameter had an average breaking load of 12.0 kg., corresponding to a tensile strength of 43 kg. per  $\text{mm}^2$  (60,000 lbs. per sq. in.). A piece  $.038^{\text{cm}}$  in diameter broke under 4.5 kg., corresponding to a tensile strength of 41 kg. per  $\text{mm}^2$ . These figures show that it is nearly as strong as copper wire, and must be classed as one of the strongest organic substances, far exceeding all kinds of wood (less than 20,000 lbs. per sq. in.), leather (5000 lbs. per sq. in.), and hemp ropes (15,000 lbs. per sq. in.).

Catgut musical strings, as furnished on the market, are twisted, and tend to untwist when subjected to tension, and to twist up again when tension is removed. In order to study their elasticity, this twist must be removed, which is accomplished by soaking the string in water. If hot water is used the string becomes very soft, and contracts greatly in length. In this condition it behaves very much like rubber; it can be stretched to nearly double its unstrained length, and when released it snaps back like a rubber band.

It is greatly weakened, however, by being wet; but it regains its strength more or less completely upon drying, as shown in the following table:

Catgut string, .038<sup>cm</sup> in diameter.  
Average breaking load before special treatment, 4.5 kg.

Number of tests.	Treatment.	Breaking load in kgs.
2	Soaked $\frac{1}{2}$ hr. in water at 30° C., then tested while wet	2.1
1	“ “ “ “ “ dried, then tested	5.0
2	Soaked .1 hr. in water at 30° C., dried for five days, then tested	4.3, 4.4
1	Soaked 5 min. in water at 90° C., then tested while wet	less than 0.5
4	“ “ “ “ “ dried, then tested	1.0-1.9

*Elongation at Rupture.*—A piece 0.062<sup>cm</sup> in diameter, and 5.9<sup>cm</sup> long, stretched to 7.0<sup>cm</sup> just before rupture, or 19 per cent of its original length. Another test gave 15 per cent. These figures include whatever stretching was due to untwisting. After rupture the pieces were too much frayed out for any determination of their length.

*Specific gravity.*—By weighing a piece of catgut (not treated with water) of known length and cross section, its specific gravity was determined as 1.18 ( $\pm 0.01$ ).

All the remaining experiments to be described were made on a violin E-string, 150<sup>cm</sup> long and 0.062<sup>cm</sup> in mean diameter (the diameter was not quite uniform, varying between 0.059 and 0.065). It was freed from its original torsion on August 20, 1904, by soaking one and a half hours in water of 30° C., and while drying it supported a load of 0.5 kg. The experiments were carried on from time to time during the following year, at intervals during the prosecution of other work.

*Hygroscopic properties.*—Upon setting up this string and sighting with a micrometer telescope at a point near its lower end, it was at once seen that the length of the string did not remain constant; and by observing at intervals and determining the humidity of the air at the same time, it was easily demonstrated that the string stretched when the dampness increased and contracted when it decreased. This is in accordance with the well-known tendency of violin strings to break in dry weather. When the weather is damp the string has to be tightened to maintain the tension to keep it in tune; with increasing dryness its tension increases until finally it snaps. The actual tension required on a violin E-string to produce the proper pitch of 640 vibrations per second may be computed from the length of string (about 33<sup>cm</sup>) and its specific mass

(0.0035 g. per cm. of length) by the well-known formula for transverse vibrations of strings, and comes out about 6 kg., or about one-half of the breaking load. During the above experiments the string carried a load of 1.0 kg, and the temperature was 20 to 25° C. The order of magnitude of the changes was 0.0002 of the length of the string for each cm. of mercury of vapor tension. Precise determination of the dependence of length on humidity was made prohibitively difficult by the phenomena described in the following paragraph.

*After-effects.*—Whenever any change was produced in the conditions, the catgut did not at once come into equilibrium under the new conditions, but did so only gradually. Thus,

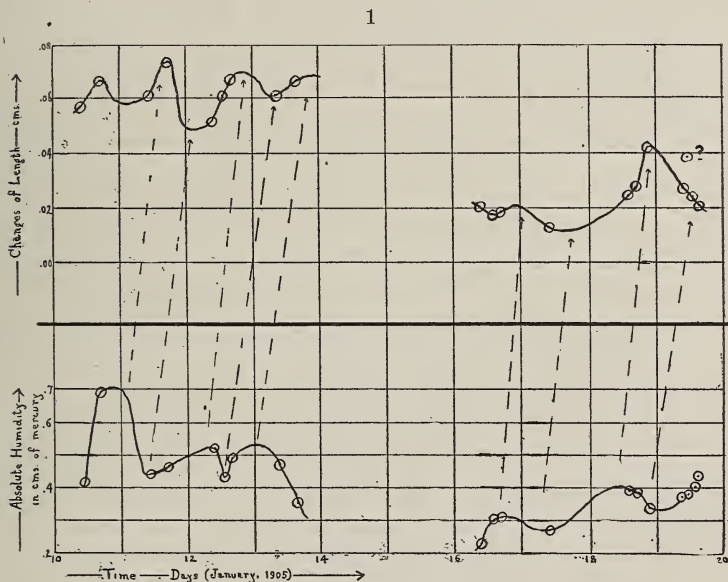
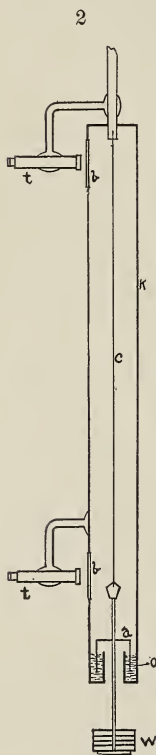

FIGURE 1.—Length and Humidity as Functions of Time.

when the load upon it was changed, it exhibited in marked degree the well-known elastic after-effect, requiring some days to come to sensible equilibrium, during which time the change in length due to change in load increased by about 25 per cent of its final amount. It was found also that the stretch due to humidity tended to continue after a change of humidity ceased; this could easily be seen in the fluctuations of humidity accompanying changes of weather; but no facilities for controlling humidity were available, and so no attempt could be made to study these phenomena thoroughly. No doubt some time is required for moisture to penetrate into the interior of the catgut. The curves of figure 1 represent change of length of the

catgut, and humidity (absolute), both as functions of time. After-effects were detected also in connection with change of temperature.

The elastic after-effect is of course responsible for the behavior of new strings on violins, which get out of tune very rapidly at first, and always in the direction of lower pitch. With greater duration of the tension the after-effect becomes less marked and the material approaches equilibrium under the imposed conditions. But if left for some time, the tendency is always towards lower rather than higher pitch, if temperature and humidity do not change.



To protect the string from changes of humidity, it was placed inside of a tube of galvanized iron ("spout-pipe"), 6 inches in diameter, and 2 meters long, the seam of which was soldered up (*k*, fig. 2). Near the top and bottom, plate glass windows (*b, b*),  $7\frac{1}{2} \times 15$  cm, were fastened into it and made moisture-tight by liberal application of thick grease ("mobilubricant") beneath the glass and around its edges. Inside the bottom of the tube a circular trough (*o*, fig. 2) 4 cm wide was soldered against it and filled with engine oil. A hanger was attached to the bottom of the catgut, and hung through the hole in the middle of the trough; to this hanger was fastened an inverted cup (*a*) of tin, which dipped into the oil of the trough. Thus the catgut was completely protected against changes of moisture in the air, and at the same time could be subjected to any desired tension by placing weights upon the hanger sticking out from the bottom of the tube. The whole arrangement was supported from the ceiling and braced against the floor. Micrometer telescopes for reading at top and bottom were supported from the tube itself. The top telescope took account of any sinking of the upper support; the distance between the two marks sighted upon on the string was 138 cm. The telescope at the bottom could be shifted bodily to keep up with stretching of the string; a reflection prism was fastened to it in front of its objective, and reflected into its field of view the image of a steel centimeter scale fastened vertically near by. In this way the shift of the telescope when moved could be measured.

*Coefficient of Thermal Expansion.*—After the catgut had been in the tube four days, readings were made upon it from



time to time, and were still found to fluctuate. Upon comparing these readings with those for temperature, it was obvious that the changes were related to it, as may be seen in figure 3 ;

3

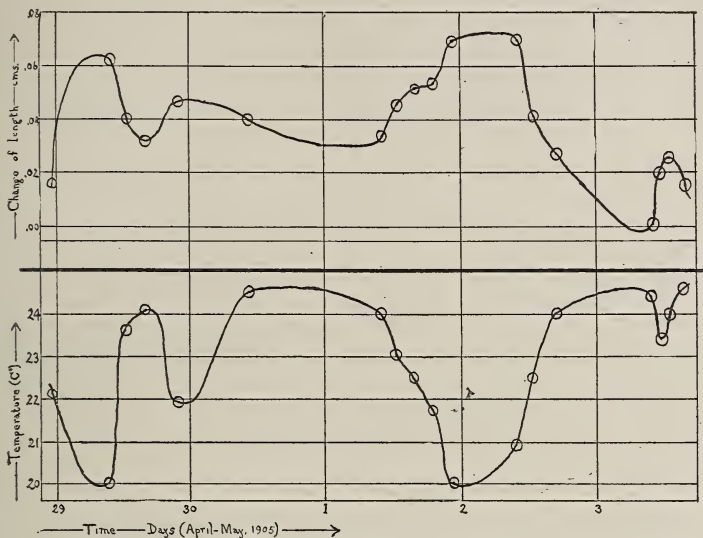

FIGURE 3.—Temperature and Length as Functions of Time.

4

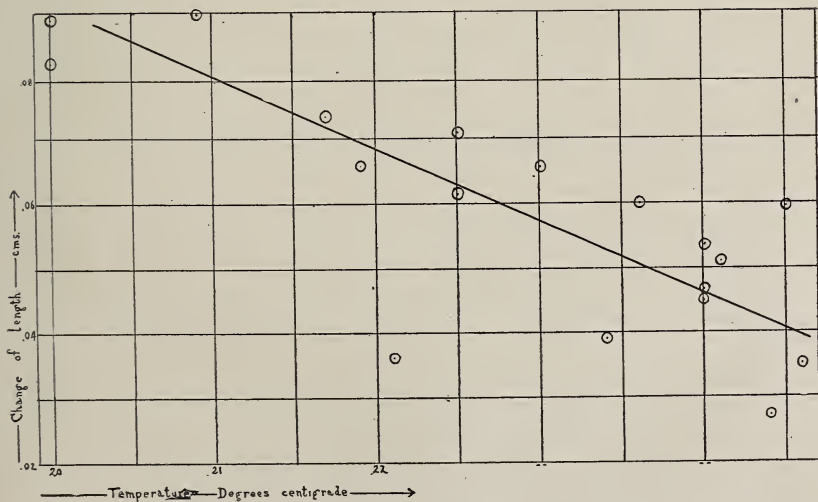

FIGURE 4.—Dependence of Length on Temperature.

but again the state of affairs is complicated by after-effects. These were simply neglected, however, and equations were set up for the determination of the coefficient of expansion, using eighteen observations; solving them by the method of least squares, the coefficient of linear expansion came out  $-0.000081$  per degree centigrade. The observations used are shown graphically in figure 4. As the coefficient of expansion comes out *negative* and larger in absolute value than for most substances, the question arises whether the data obtained were not

5

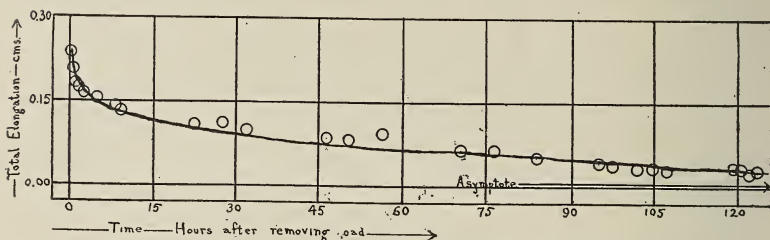

FIGURE 5.—Elastic After-effect upon removing 0.5 kg.

6

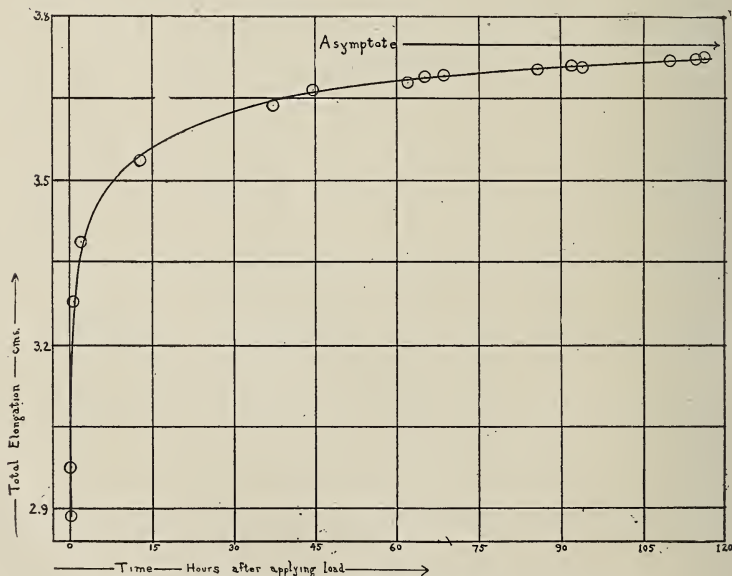
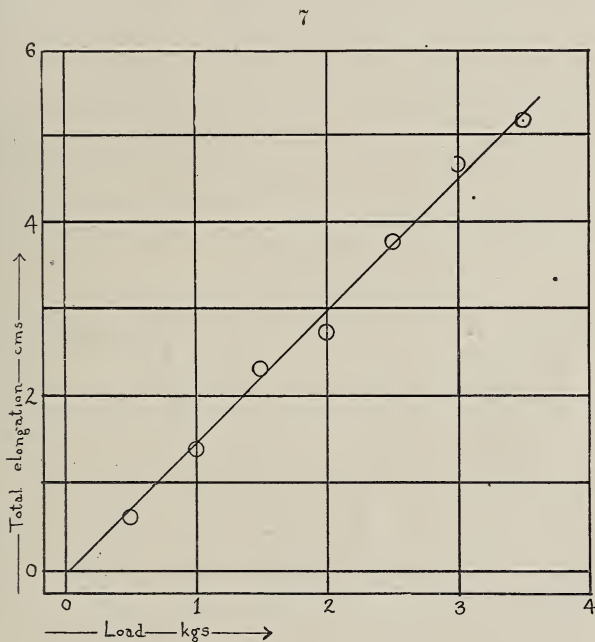

FIGURE 6.—Elastic After-effect upon applying 2.5 kgs.

influenced by humidity. In the enclosure containing the catgut, the *absolute* humidity was constant, but the *relative* humidity increased as the temperature fell; and it may be that under such conditions the material tends to absorb moisture and thus increase in length. It is possible, therefore, that in a perfectly dry atmosphere, the behavior of catgut under varying temperature might be quite different.

*Elasticity.*—To get at the true elastic properties of the material it would be necessary, after each change of load, to wait until the disappearance of the after-effect before determining the corresponding length of the string. In strictness,



an infinite time would be requisite for this; but practically the following procedure can be adopted, and was employed in these experiments: After each change of load, observations on the length of the string were made at intervals of a few hours for several days, and corrected for thermal expansion. From the data thus obtained, a curve was plotted with times for abscissas and lengths for ordinates; and from this curve the final length which the string tended to reach with disappearing after-effect, was estimated. Of course such an estimation involves considerable uncertainty and arbitrariness; but no other course seems available, as long as experiments must be

limited to finite time. Two of the curves obtained in this manner are exhibited in figures 5 and 6, together with their asymptotes as estimated. Such curves were taken after each change of load; but it is not thought to be of any interest here to submit more than two of them, or to present tables of the numerical data from which the curves are plotted.

The results obtained in this manner are summarized in the accompanying table. After any load had acted for a few days it was removed, and the string left unloaded a few days before the next load was applied. The individual readings were made to thousandths of centimeters; but the estimation of the length to which the string tended at infinite time was carried out only to hundredths. The first column of the table gives the loads, in kilograms, placed upon the hanger, which itself weighed about 0.5 kg.; the third column gives the total elongation after disappearance of the after-effect, estimated as explained above; the sixth column gives the after-effect, of change of strain from the first instant (practically about 60 seconds) after applying the load until final equilibrium is reached, expressed as percentage of the total final strain; the other columns require no explanation.

Violin E-string, 0.062<sup>cm</sup> in diameter.

Load, in kgs.	Stress in kgs. per mm <sup>2</sup> .	Total elongation in cms.	Strain.	Young's modulus in kgs. per mm <sup>2</sup> .	After-effect.	Time the load acted, in days.	Mean temperature, ° C.
0.5 { (applied) } { (removed) }	1.66	{ 0.59 } { 0.62 }	0.0044	378	{ 30% } { 33% }	5	24
1.0 (applied)	3.31	1.39	0.0101	328	44%	6	24
1.5 (removed)	4.97	2.26	0.0164	303	26%	5	25
2.0 { (applied) } { (removed) }	6.63	{ 2.70 } { 2.75 }	0.0198	335	{ 22% } { 29% }	4	28
2.5 { (applied) } { (removed) }	8.29	{ 3.78 } { 3.73 }	0.0272	304	{ 22% } { 29% }	5	31
3.0 (applied)	9.95	4.66	0.0338	294	20%	8	27
3.5 (applied)	11.60	5.17	0.0375	310	15%	6	28

*Young's Modulus.*\*—The mean value of Young's modulus from these experiments comes out 322 kgs. per mm<sup>2</sup>, or 458,000

\* The values of Young's modulus given in the above table are obtained by direct division of each stress by the corresponding strain. In strictness, Young's modulus should be determined from the slope of the stress-strain curve at the origin. But in the special case that the stress-strain curve is a straight line, the quotient of stress by strain for any point of the curve gives the same result as the slope at the origin. The data under discussion not being sufficiently regular to determine the true form of the stress-strain curve, it is taken as a straight line within the limits of the experiments; and this justifies the above method of determining Young's modulus.

lbs. per sq. in. If observations taken immediately after applying the loads had been used, instead of those after the disappearance of the after-effect, we would have about 400 kg. per  $\text{mm}^2$  for Young's modulus; and this latter figure represents the elastic resistance of the material to a stress applied for a short time, as in longitudinal vibrations of the string.

*Limit of Elasticity.*—As is seen from the table, slight permanent set appears, though not with great certainty, after applying 2.5 kg (+0.5 kg. for the hanger). That makes the limit of elasticity about 8 kg. per  $\text{mm}^2$ , corresponding to a strain of 2.7 per cent.

*Stress-strain Relation.*—The results tabulated above are shown graphically in figure 7. It is clear from it that Hooke's law is *approximately* true; but the results obtained are too irregular to furnish ground for any definite statement as to deviations from Hooke's law.

Sewickley, Penn.

ART. XL.—*The Use of the Rotating Cathode for the Estimation of Cadmium taken as the Chloride*; by CHARLES P. FLORA.

[Contributions from the Kent Chemical Laboratory of Yale Univ.—exl.]

IN a previous paper\* the author has described the use of the rotating cathode for the estimation of cadmium taken as the sulphate. In the present paper a similar study has been made of the behavior of cadmium when taken in the form of the chloride. Some differences are to be expected, since it has been established with some certainty that cadmium chloride, when subjected to electrolysis, forms not only positive cadmium ions and negative chlorine ions, but also complex cadmium-chlorine negative ions; and, in addition, the chlorine, when set free, does not recombine with the water, to set free oxygen, but exists in the solution in its free state. That there are some very important differences a few qualitative experiments showed, so that the study of the estimation of cadmium when taken in the form of this salt was now undertaken.

A solution was made up to a convenient strength, and the standard determined by the mean of several closely agreeing determinations by the carbonate method, which the author had carefully tested and found to be perfectly reliable. This showed 0.1589 gm. of cadmium in 30<sup>cm</sup><sup>3</sup> of the solution, or 0.0052966 gm. per cubic centimeter.

I. *In Solutions containing Sulphuric Acid.*

The procedure with cadmium chloride was the same as with the cadmium sulphate, and the results were very satisfactory. But emphasis is to be laid upon the dilution in this case especially, for it was found that from the more dilute solution it is almost impossible to drive the last traces of cadmium. A dilution of 45<sup>cm</sup><sup>3</sup> was found to give the most satisfactory results. To this solution ten drops of sulphuric acid of 1:4 dilution were added before electrolysis. The following results were obtained under these conditions:

No.	Cd. gm.	Cur't = amp.	N. D. <sub>100</sub> amp.	E.M.F. vts.	Time. min.	Cd. fd. gm.	Error. gm.
1.	0.1059	1.0-1.5	3.0-4.5	6.5-7.8	25	0.1054	—0.0005
1.	0.1059	2.0-3.0	6.0-9.0	7.8	15	0.1058	—0.0001

II. *In Solutions containing Acetates.*

The acetate method has proved one of the most satisfactory for the estimation of cadmium sulphate, but strangely enough,

\* This Journal, xx, 268 (1905).

it was found to be absolutely unfitted for the estimation of cadmium when taken as the chloride. The deposited metal was always spongy, often non-adherent and unfitted for quantitative work. The sponginess was less marked when no potassium sulphate was present, but the metal was still poorly adherent and unweighable. The modifications tried are given for the sake of comparison in the following table. The current potential throughout was 7.8 volts, while the dilution, excepting in experiment No. 4, was 45<sup>cm</sup>³. In No. 4 a dilution of 65<sup>cm</sup>³ was tried, but it offered no apparent advantage.

No.	Cd. gram.	NaOC <sub>2</sub> H <sub>3</sub> O. gram.	K <sub>2</sub> SO <sub>4</sub> . gram.	Cur't= amp.	N. D <sub>100</sub> amp.	Time. min.	Notes.
1.	0.1324	1.5	0.5	1.5	4.5	13	very spongy
2.	0.1324	1.5	none	1.0	3.0	8	0.1314 gram. fd.
3.	0.1059	1.0	"	0.75	2.25	20	non-adherent.
4.	0.1059	1.5	0.5	1.5	4.5	—	{ spongy, non- adherent
5.	0.1059	1.5	none	1.0	3.0	—	{ 2 <sup>cm</sup> ³ formalin added, spongy
6.	0.1059	1.5	"	0.75	2.25	—	non-adht., cryst.
7.	0.1059	0.5	0.5	1.0	3.0	—	" "

### III. In Solutions containing Cyanides.

The use of a cyanide solution gave results with the chloride of cadmium as satisfactory as were given when the sulphate of cadmium was taken. As in that case, care must be taken to avoid foaming of the solution. The best dilution seemed to be 65<sup>cm</sup>³. The time required is a trifle longer than in the estimation of cadmium sulphate by this method. The following results were obtained:

No.	Cd. gram.	KCN. gram.	NaOH. gram.	Cur't = amp.	N. D <sub>100</sub> amp.	E.M.F. vts.	Time. min.	Cd. fd. gram.	Error. gram.
1.	0.1324	1.5	1.0	4	12	7.8	35	0.1322	-0.0002
2.	0.1324	1.5	1.0	4	12	7.8	40	0.1317	-0.0007

In experiment No. 2 there was much foaming, and a trace of cadmium remained in solution, the deposition being much retarded.

### IV. In Solutions containing Pyrophosphates.

The different modifications of the pyrophosphate method gave results which were quite satisfactory, and in every respect comparable with the results obtained with this electrolyte in the estimation of cadmium sulphate. As was the case with that salt, the use of ammonium hydroxide to dissolve the precipitate gave the most satisfactory results; while after that, sulphuric acid seemed to be the most suitable

solvent. The deposits obtained from solutions to which were added free phosphoric acid showed a slight tendency toward sponginess. When hydrochloric acid was added, the deposits were good but deposition was slow. The total volume in each case was 45<sup>cm</sup><sup>3</sup>; the amount of sodium pyrophosphate used was 9.5 grm.; while the current potential was 7.8 volts.

The following results were obtained:

No.	Cd. grm.	Solvent.	Cur't = amp.	N. D <sub>100</sub> . amp.	Time. min.	Cd. fd. grm.	Error. grm.
1.	0.1324	NH <sub>4</sub> OH, conc., 1 <sup>cm</sup> <sup>3</sup> .	0.5	1.5	15	0.1327	+0.0003
2.	0.1324	H <sub>2</sub> SO <sub>4</sub> , (1.4), 12 dps.	0.75	2.25	35	0.1328	+0.0004
3.	0.1342	H <sub>3</sub> PO <sub>4</sub> (sp. gr. 1.7), 15 dps.	0.75-1.0	2.25-3.0	30	0.1331	+0.0007
4.	0.1324	HCl, 1 : 4, 15 dps.	0.7-0.5	2.1-1.5	45	0.1319	-0.0005

#### V. *In Solutions containing Phosphates.*

With cadmium chloride, hydrogen disodic phosphate must be used with even more care than with cadmium sulphate, if deposits which are even slightly satisfactory are to be obtained; and even when used with caution, the tendency to form spongy deposits is so persistent that this method is not to be recommended where other methods are available. The following are the solutions tried, the concentration being 45<sup>cm</sup><sup>3</sup> throughout:

No.	Cd. grm.	HNa <sub>2</sub> PO <sub>4</sub> . grm.	H <sub>3</sub> PO <sub>4</sub> . (sp. gr. -1.7)	Cur't = amp.	N. D <sub>100</sub> . amp.	E.M.F. vts.	Time. min.	Cd. fd. grm.	Error grm.
1.	0.1059	0.25	5 <sup>cm</sup> <sup>3</sup>	2.0-3.0	6.0-9.0	7.8	15	0.1082	+0.0023
2.	0.1324	0.25	2.5 <sup>cm</sup> <sup>3</sup>	2.0-3.0	6.0-9.0	7.8	13	0.1344	+0.0020
3.	0.1324	0.20	10 dps	1.0	3.0	7.8	15	0.1330	+0.0006
4.	0.1324	0.20	6 dps	0.25	0.75	7.8	35	0.1310	-0.0014

Numbers 1 and 2 gave spongy deposits; number 4 showed no color upon testing the solution at the end of the operation with hydrogen sulphide, but this test does not seem to be very sensitive in this solution. Number 3 seems to represent the best conditions.

#### VI. *In Solutions containing Oxalates.*

Several qualitative tests, using conditions identical with those giving the least unsatisfactory deposits with cadmium sulphate, were tried upon the cadmium chloride, with like unsatisfactory results, so that the work upon the oxalate method was not pursued further.

#### VII. *In Solutions containing Urea, etc.*

A few qualitative tests seemed to indicate that solutions containing urea, formaldehyde or acetaldehyde would furnish very satisfactory media for the estimation of cadmium, taken in the form of the chloride, but further experimentation proved these appearances to be deceptive. Under these conditions,



the cadmium is deposited much more quickly from a solution of its chloride than of the sulphate, and the deposit in the earlier part of the precipitation appears to be very satisfactory. But the chlorine set free apparently has some action upon the organic compound present to produce substances detrimental to the process. With care, however, satisfactory results may be obtained, as may be seen from a study of the following tables:

SERIES A.—UREA.

No.	Cd. gm.	Urea. gm.	Cur't = amp.	N.D. <sub>100</sub> . amp.	E.M.F. vts.	Time. min.	Tot. vol. cm <sup>3</sup> .	Cd. fd. gm.	Error. gm.	Notes.
1.	0.1324	3	1.0	3.0	12	20	60	0.1312	-0.0012	{ spongy, not all out
2.	0.1324	2	1.0	3.0	12	30	60	0.1336	+0.0012	{ spongy, not all out
3.	0.1324	3	1.0	3.0	7.8	15	55	0.1342	+0.0018	{ very spongy, all out
4.	0.1324	2	0.25	0.75	7.8	25	60	0.1324	±0.0000	all out
5.	0.1324	2	0.5	1.5	12	20	60	0.1333	+0.0009	{ slt. spy. all out
6.	0.1324	1	1.0	3.0	12	20	60	0.1370	+0.0046	{ very spongy
7.	0.1324	1.5	0.25-0.5	0.75-1.5	7.8	30	60	0.1328	+0.0004	good
8.	0.1324	1.5	0.25-0.5	0.75-1.5	7.8	30	60	0.1329	+0.0005	fair

The amount of urea present, therefore, should be between 1.5 gm. and 2 grms., and the current potential should not exceed 8 volts, instead of the 12 volts permissible when cadmium sulphate was used. The test with hydrogen sulphide does not seem to be very delicate in this solution, so that at least 30 minutes should be allowed for each determination. Some writers recommend the testing of the end-point in similar cases by raising the level of the liquid upon the cathode, but this was not proved of much value in this work, as the amount of metal deposited upon the fresh cathode surface from the solutions near the end of the process is imperceptible.

A solution to which formaldehyde was added gave the following results:

SERIES B.—FORMALDEHYDE (FORMALIN).

No.	Cd. gm.	Form. cm <sup>3</sup> .	Cur't = amp.	N.D. <sub>100</sub> . amp.	E.M.F. vts.	Time. min.	Tot. vol. cm <sup>3</sup> .	Cd. fd. gm.	Error. gm.	Notes.
1.	0.1324	3.0	0.25-1.5	0.75-4.5	7.8	20	45	0.1333	+0.0009	fair
2.	0.1324	2.0	0.50-2.0	1.50-6.0	11.8	15	45	0.1330	+0.0006	slt. spgy
3.	0.1324	1.5	0.75	2.25	7.8	30	60	0.1324	±0.0000	compact
4.	0.1324	1.5	1.0	3.0	7.8	35	60	0.1325	+0.0001	"

It will be seen from these results that it is better to use a somewhat smaller quantity of formaldehyde than was used with the cadmium sulphate; the current potential should not exceed 8 volts; while the solution should be rather dilute ( $60\text{cm}^3$ ).

These cautions are of even greater importance when acetaldehyde is used, if satisfactory results are to be obtained, as the following results show:

SERIES C.—ACETALDEHYDE (95%).										
No.	Cd. gram.	Aldehyd. (95%) $\text{cm}^3$ .	Cur't = amp.	N.D. <sub>100</sub> . amp.	E.M.F. vts.	Time. min.	Tot. vol. $\text{cm}^3$ .	Cd. fd. gram.	Error. gram.	Notes.
1.	0.1324	2.0	0.2-0.7	0.6-2.1	7.8	30	60	0.1311	-0.0013	} not all out
2.	0.1324	1.5	0.2-0.75	0.6-2.25	7.8	30	60	0.1346	+0.0022	
3.	0.1324	0.5	0.2-1.0	0.6-3.0	7.8	65	60	0.1307	-0.0017	} spongy, not all out
4.	0.1324	1.0	0.1-0.75	0.3-2.25	8.0	35	60	0.1328	-0.0001	

#### VIII. *In Solutions containing Formates and Tartrates.*

Like cadmium sulphate, so also cadmium chloride gave negative results when solutions containing in addition potassium formate in the presence of formic acid were subjected to electrolysis. Moreover, when no formate was added, but formic acid alone, the results were still unsatisfactory. To solutions containing 0.1324 gram. of cadmium in the form of the chloride was added  $1.5\text{cm}^3$  of formic acid, the whole diluted to  $50\text{cm}^3$ , and electrolysis conducted under potentials of 7.5 and 11.8 volts. In each case the precipitate was spongy and non-adherent, while the solution persistently held traces of cadmium, even after subjecting to the current nearly two hours.

Solutions containing tartaric acid behaved in a similar manner. In the presence of 3 gram. of tartaric acid, under current tensions of 8 and 12 volts, the precipitated metal peeled from the cathode during revolution, the deposit was spongy, and deposition seemed to be complete at no point of the operation.

## SCIENTIFIC INTELLIGENCE.

## I. CHEMISTRY AND PHYSICS.

1. *The Formation of Ozone by Ultra-violet Light.*—FISCHER and BRAEMER, by employing a mercury-vapor lamp with quartz walls, have studied the effect of ultra-violet light upon oxygen. They have found that ozonization takes place if the temperature is not too high, for above  $270^{\circ}$  ozone is decomposed more rapidly than it is formed. Thorough cooling of the oxygen by means of a water-jacket increased the yield of ozone, while a greater intensity of the light of the lamp also increased the yield to a certain limit and then decreased it, probably on account of the effect of greater heating. Upon doubling the speed of the oxygen through the apparatus the total amount of ozone formed was nearly doubled, but the percentage of ozone formed was somewhat diminished. The authors believe that their experiments show the correctness of Warburg's view, that the formation of ozone by the silent electric discharge is due to the ultra-violet light thus formed. A short time ago one of the authors found that their lamp could produce in a few hours the violet coloration of glass containing manganese, which is effected by sunlight in high mountainous regions in months or years, and in our low regions only after longer periods, because the ultra-violet part of its spectrum is strongly absorbed by the earth's atmosphere. By this absorption of ultra-violet sunlight by our atmosphere ozone results in the upper layers of air, and when it sinks to lower regions it is decomposed by oxidizable substances.—*Berichte*, xxxviii, 2633.

H. L. W.

2. *A New Reagent for Nickel.*—Heretofore there has been no characteristic and delicate reaction for nickel, particularly in the presence of considerable amounts of cobalt. The most delicate of the known tests is probably the brown color produced by alkali thiocarbonates, but this is interfered with by the presence of cobalt. TSCHUGAEFF has recently found that  $\alpha$ -dimethylglyoxime,

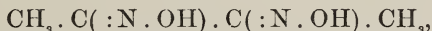

is an extraordinarily delicate and characteristic reagent for the metal under consideration. To make the test, the solution is first freed from any excess of acid by the addition of alkali (preferably an excess of ammonia or sodium acetate solution), then some powdered dioxime is added and the solution is heated to boiling for a short time. If the solution is not exceedingly dilute, a scarlet precipitate is produced at once having the composition  $\text{NiD} \cdot \text{DH}_2$ , where  $\text{DH}_2$  represents dioxime. When very small amounts of nickel are present a yellowish liquid is obtained, from which, after cooling, the red precipitate is deposited after a few minutes, whereby the excess of dioxime which separates at

the same time is colored distinctly pink. The delicacy of this reaction is so great that it is very distinct in solutions containing only one part of nickel to 400,000 parts of water. The reaction is not at all masked by the presence of ten times as much cobalt as nickel, but since cobalt salts also react with the dimethylglyoxime with the formation of a brown compound, it is expedient to modify the process when much cobalt is present by adding a very large excess of ammonia to the liquid, then shaking repeatedly in order to oxidize the cobalt to complex cobaltic-ammonia compounds, and then proceeding as before. In this case, with not too minute amounts of nickel, the reaction appears at once, when the liquid is boiled, by the formation of a scarlet froth which rises upon the walls of the test-tube, but generally it is necessary to filter the cooled liquid and to wash the residue with water in order to detect its pink color. The author gives a method for preparing the new reagent, and states that it may be obtained commercially from Kahlbaum.—*Berichte*, xxxviii, 2520.

H. L. W.

3. *The Electrolytic Dissociation Theory with some of its Applications*; by HENRY P. TALBOT and ARTHUR A. BLANCHARD, 8vo, pp. 84. New York, 1905 (The Macmillan Co.).—This is an elementary treatise for the use of students of chemistry. It deals with the fundamental topics of physical chemistry in a very clear and simple manner, and it is undoubtedly a valuable text-book for students who are not far enough advanced to take up the subject more elaborately. The six chapters of the book have the following titles: "Evidences of Electrolytic Dissociation afforded by a Study of the Properties of Solutions," "The Law of Mass Action and the Chemical Behavior of Electrolytes," "Electrolytic Solution Pressure," "Oxidation and Reduction," "The More Common Ions and their Characteristics," "Experiments."

H. L. W.

4. *Soils and Fertilizers*; by HARRY SCHNEIDER, 8vo, pp. 294. Easton, Pa., 1905 (The Chemical Publishing Co.).—This book gives in condensed form the principles of chemistry which have a bearing upon the conservation of soil fertility and the economic use of fertilizers. While it is intended particularly as a text-book for students in agricultural colleges, and includes a course of laboratory experiments for such students, it presents the subject in such a practical manner that it should find extensive use among farmers. The present second edition has been entirely rewritten, and has received the addition of new material.

H. L. W.

5. *Engineering Chemistry*; by THOMAS B. STILLMAN, Third Edition, 8vo, pp. 597. Easton, Pa., 1905 (The Chemical Publishing Co.).—The third edition of this well-known work on technical analysis contains much new matter, especially in regard to asphalts, lubricating-oils, Portland cement, and the technology of the products of the blast-furnace. In its present form the book will be more useful than ever to those who are interested in commercial chemistry.

H. L. W.

6. *A Text-Book of Chemical Arithmetic*; by H. L. WELLS, 12mo, pp. 169, 1905. New York (John Wiley & Sons).—Every instructor in chemistry knows how difficult it is to induce students to use their reasoning powers in solving simple problems. The tendency is always to use a formula or a factor without knowing or caring what these may mean. This text-book is designed to teach chemical arithmetic, but on a basis of reason rather than rules. Part I on approximate numbers deals with calculations from measurements involving errors of observation. The abbreviated methods of multiplication and division are also given. The rest of the book deals with chemical calculations relating to weights, to gases, and to volumetric analysis. Throughout the book, a large number of very practical problems is given. A student who has once solved these problems intelligently should certainly have no further trouble with chemical calculations. In an appendix, several convenient tables are given, including a table of logarithms.

H. W. F.

7. *A Text Book of Physiological Chemistry for Students of Medicine*; by JOHN H. LONG, Professor of Chemistry in Northwestern University Medical School, Chicago. Pp. viii + 424. Illustrated. Philadelphia, 1905 (P. Blakiston's Son).—In this volume are presented in a clear and simple form the necessary facts and principles underlying the science of physiological chemistry, written for use by students in medical schools, but few references are made to the literature. Besides the general topics usually treated of in a book of this character there is given an outline of the chemical phases of recent theories of immunity together with explanations of the application of the methods of cryoscopy and electrical conductivity and other physical processes in the field of chemistry related to medicine. The book is well adapted to the purpose for which it was written and should be well received.

F. P. UNDERHILL.

8. *Formation of Helium from the Radium Emanation*.—In answer to many inquiries called forth by an article on this subject, published in the *Berichte d. naturf. Ges. Freiburg i Br.* xvi, p. 222, 1904, F. HIMSTEDT and G. MEYER relate further experiments upon this subject. They have repeated their work with  $\text{RaBr}_2$  and also with  $\text{BaBr}_2$  by the same method. Using a much greater amount of material, they never found a trace of a helium line. They still possess, however, three tubes which show with the greatest ease the helium spectrum, which could not have come from the air of the room or from any source but the emanation.

In order to determine whether any occlusion phenomenon similar to the occlusion of hydrogen by palladium was concerned in the appearance of helium, they made the following experiments:

Palladium foil filled with hydrogen was placed in a quartz tube connected to a vacuum pump, and in the process of exhaustion was heated to a red heat and was flushed out with  $\text{CO}_2$  until every trace of the hydrogen spectrum disappeared. After three

days, on heating, the hydrogen spectrum reappeared. After eight days, on repetition of the heating, the hydrogen lines again appeared. Further examination was prevented by the breaking of the tube.

The following experiment with cleveite led to a totally different result. In a combustion tube 0.3 g. of cleveite with  $\text{SO}_4\text{KH}$  was strongly heated and the tube flushed with hydrogen until no helium lines could be seen. The tube was then exhausted as far as possible. After three days, perhaps, there was a trace of the helium spectrum; but repeated heating and pumping disclosed in fourteen days no trace of helium. This experiment was repeated without  $\text{SO}_4\text{KH}$  with the same result.

In marked contrast to this experiment was the following: About 40 mg.  $\text{RaBr}_2$  were so strongly heated in a highly exhausted quartz tube that the substance resublimed in a cooled end of the tube. The tube was flushed with hydrogen and exhausted, and on the following day the substance was again resublimed; no trace of the helium spectrum was seen. In six weeks, however, the helium spectrum could be readily produced in the tube. These experiments appear to the author to dispose of the theory of occlusion.

They point out that there may be a possibility of the formation of a helid. Instead of pure  $\text{RaBr}_2$  we may be dealing with a mixture of this substance with a small quantity of a hypothetical helid. However this may be, they conclude that there is no doubt of a connection between the radium emanation and helium.—*Ann. der Physik*, No. 10, 1905, pp. 905–1008. J. T.

9. *Blondot's "Emission pesante."*—M. R. BLONDOT published in the *Comptes Rendus* issues of 1904 two papers on a phenomenon analogous to the so-called N-rays, to which he gave the name "emission pesante." A preparation of calcium sulphide becomes more luminescent under the influence of this emission. Blondot states that he has not only observed this increase in luminescence, but also an effect of the magnetic field on the emission. Rudolf F. Pozdena has made an exhaustive examination of the effects claimed by Blondot and cannot find any evidence of the new emission if the observer does not conduct the experiments himself. The phenomenon is a subjective one and may arise in the anatomy of the retina of the eye by a species of autosuggestion leading to a "Will to believe."—*Ann. der Physik*, No. 6, 1905, pp. 104–131. J. T.

10. *Diffusion of Nascent Hydrogen through Iron.*—A. WINKLEMAN has conducted a long series of experiments upon this subject with the following conclusions:

The nascent hydrogen being formed on the outside of a hollow iron cylinder which was closed at the bottom and connected at the other end with an air pump, the iron cylinder serving as a cathode in a suitable electrolytic cell, it was found:

(1) The quantity of gas diffusing from the outside to the inside of the cylinder was independent of the pressure inside the cylin-

der over a range of 0 to 89<sup>cm</sup> of mercury. The quantity, moreover, was not altered if the exterior pressure on the iron cylinder was varied from one to a half atmosphere. The pressure, therefore, under which the gas is driven through the iron is of a different nature from that which one might suppose and has an under limit of 58 atmospheres.

(2) The diffusion with constant current strength increases notably with the temperature; and if one puts the diffusion proportional to a power of the absolute temperature, this power is at least equal to 5.

(3) The diffusion increases at constant temperature with increasing current strength but not in a proportionate manner.

(4) From 1 and 3 one can understand the observations of Nernst which show that the pressure of the ions formed electrolytically can be very great and that this pressure depends upon the potential difference under which the electrolysis occurs. In view of this great pressure which drives the ions through the metal, one can understand the no effect on one to a half atmosphere mentioned in 1; also one does not wonder at the results of Bellanti and Lussana, who found that diffusion occurred even against a pressure of 20 atmospheres.

(5) At constant temperature and similar conditions of solutions and electrodes the quantity of diffusion was nearly proportional to the potential difference.—*Ann. der Physik*, No. 9, 1905, pp. 589-626.

J. T.

11. *Landolt-Börnstein Physikalisch-chemische Tabellen*. Dritte umgearbeitete und vermehrte Auflage, herausgegeben von Dr. RICHARD BÖRNSTEIN und Dr. WILHELM MEYERHOFFER. 861 pp. Berlin, 1905 (Julius Springer).—The first edition of this very important work was published in 1883 and the second in 1894. The decade that has passed since the latter date has seen a very high degree of activity in physical research and a corresponding increase in the amount of physical data. In the working over and arrangement of this large amount of material, the editors have had the support of upwards of forty associates, chiefly in Germany; the work has been carried through with the support of the Prussian Academy of Sciences. The volume opens with the international atomic weights of 1903 calculated with oxygen = 16. Then follow tables of latitude and longitude of important places and then the tables of physical data relating to volume, density, elasticity, tension, etc.; then those pertaining to heat, light, elasticity, magnetism and sound. The name of the worker who has elaborated each series of tables is given at the bottom of each page and following each subject are the references to the literature giving fully the authorities quoted. The comprehensive scope, thoroughness and accuracy of this great work give it a unique place in physical literature and make it essential to every laboratory.

## II. GEOLOGY AND MINERALOGY.

1. *United States Geological Survey*: CHARLES D. WALCOTT, Director.—Recent publications of the U. S. Geological Survey are included in the following list. Notices are for the most part deferred till a later number.

FOLIOS: No. 122.—Tablequah Quadrangle, Indian Territory—Arkansas; by JOSEPH A. TAFF.

No. 123.—Elders Ridge Quadrangle, Pennsylvania; by RALPH W. STONE.

No. 124.—Mount Mitchell Quadrangle, North Carolina—Tennessee; by ARTHUR KEITH.

No. 125.—Rural Valley Quadrangle, Pennsylvania; by CHARLES BUTTS.

MONOGRAPH, No. XLVIII.—Status of the Mesozoic Floras of the United States. Second Paper; by LESTER F. WARD, with the collaboration of William M. Fontaine, Arthur Bibbins and G. R. Wieland. Part I, Text, pp. 616. Part II, plates i–cxix.

PROFESSIONAL PAPERS: No. 34.—The Delavan Lobe of the Lake Michigan Glacier of the Wisconsin Stage of Glaciation and Associated Phenomena; by WILLIAM C. ALDEN. Pp. 106, with 15 plates. See p. 409.

No. 36.—The Lead, Zinc and Fluorspar Deposits of Western Kentucky; by E. O. ULRICH and W. S. TANGIER-SMITH. Part I, Geology and General Relations by E. O. Ulrich. Pp. 1–105, plates i–vii. Part II, Ore Deposits and Mines by W. S. Tangier-Smith. Pp. 107–218, plates viii–xv, 31 text-figures.

No. 38.—Economic Geology of the Brigham Mining District, Utah; by JOHN MASON BOUTWELL. With a Section on Areal Geology by ARTHUR KEITH and an Introduction on General Geology by SAMUEL FRANKLIN EMMONS. Pp. 413, 49 plates, 10 figures.

BULLETINS—No. 208.—Descriptive Geology of Nevada south of the Fortieth Parallel and Adjacent Portions of California; by JOSIAH EDWARD SPURR. Second edition. Pp. 229, 8 plates. Map in pocket.

No. 235.—A Geological Reconnaissance across the Cascade Range near the Forty-ninth parallel; by GEORGE OTIS SMITH and FRANK C. CALKINS. Pp. 103, 4 plates. It is found that “the Cascade Mountains near the forty-ninth parallel are composed in greater part of igneous rocks that belong mainly to great batholithic masses of rather acidic composition quite comparable (in volume) with the immense intrusions of the Sierra Nevada.”

No. 237.—Petrography and Geology of the Igneous Rocks of Highwood Mountains, Montana; by LOUIS VALENTINE PIRSSON. Pp. 208, 7 plates, 8 figures.

No. 245.—Results of Primary Triangulation and Primary Traverse, fiscal year 1903–04; by SAMUEL S. GANNETT. Pp. 328 with map.



No. 247.—The Fairhaven Gold Placers, Seward Peninsula, Alaska ; by FRED H. MOFFIT. Pp. 85, 14 plates, 2 figures.

No. 248.—A Gazetteer of Indian Territory ; by HENRY GANNETT. Pp. 70.

No. 251.—The Gold Placers of the Fortymile, Birch creek and Fairbanks Region, Alaska ; by LOUIS M. PRINDLE. Pp. 89, 16 plates.

No. 253.—Comparison of a Wet and Crucible-fire methods for the Assay of Gold Telluride Ores, with notes on the errors occurring in the operations of fire assay and parting ; by W. F. HILLEBRAND and E. T. ALLEN. Pp. 30.

No. 254.—Report of Progress in the Geological Resurvey of the Cripple Creek District, Colorado ; by WALDEMAR LINDGREN and FREDERICK LESLIE RANSOME. Pp. 34.—Besides the details of more purely economic importance it is noted that in the deeper workings much annoyance and even serious interference with work has been experienced from mine gases, often in spite of vigorous measures for ventilation. The analyses showed the gas to be a mixture of nitrogen with about 20 per cent carbon dioxide and a small amount of oxygen. The authors believe that it represents the last exhalations from the throat of the extinct Cripple Creek volcano.

No. 256.—Mineral Resources of the Elders Ridge Quadrangle, Pennsylvania ; by RALPH W. STONE. 86 pp., 12 plates, 4 figures.

No. 257.—Geology and Paleontology of the Judith River Beds ; by T. W. STANTON and J. B. HATCHER ; with a chapter on the Fossil Plants ; by F. H. KNOWLTON. Pp. 174, 19 plates.

No. 262.—Contributions to Mineralogy from the U. S. Geological Survey ; by F. W. CLARKE, W. F. HILLEBRAND and others. Pp. 147, 12 text-figures.

No. 263.—Methods and Costs of Gravel and Placer Mining in Alaska ; by CHESTER WELLS PURINGTON. Pp. 273, 42 plates, 49 figures.

No. 266.—Paleontology of the Malone Jurassic Formation of Texas ; by F. W. CRAGIN ; with stratigraphic notes on Malone Mountain and the surrounding region near Sierra Blanca, Texas ; by T. W. STANTON. Pp. 172, 29 plates.

No. 267.—The Copper Deposits of Missouri ; by H. F. BAIN and E. O. ULRICH. Pp. 52.

No. 271.—Bibliography and Index of North American Geology, Paleontology, Petrology and Mineralogy for the year 1904 ; by FRED BOUGHTON WEEKS. Pp. 218.

WATER SUPPLY and IRRIGATION PAPERS.—Nos. 97, 98, 99, 100, 103, 106, 107, 108, 109, 110, 111, 112, 113, 114, 115, 116, 117, 118, 119, 124, 125, 127, 128, 129, 130, 131, 132, 133, 134, 135, 136, 141, 143, 144, 146, 149.

2. *Osteology of Baptonodon* (Marsh) ; by C. W. GILMORE. Memoirs of the Carnegie Museum, Vol. II, No. 2, August, 1905.—Mr. Gilmore's excellent paper gives us for the first time a satisfactory discussion of the osteological structure of the Jurassic

Ichthyosauria of America. Notes by Marsh and Knight have acquainted us with the essential characters of the paddles, but little information concerning the remainder of the skeleton has been published, and investigators working on related groups have had no satisfactory basis for comparison with these important forms. The specimens studied by Mr. Gilmore include practically all of the known *Baptanodon* material. The figures presented represent the complete structure of the skull in all its aspects, the pectoral girdle, the anterior limb, and the anterior portion of the vertebral column. The posterior limb is not certainly known.

The characters of the dentition of *Baptanodon*, for the original discovery of which we are indebted to Mr. Gilmore, have been summed up in the statement that: "*Baptanodon* was well provided with comparatively small, somewhat slender but functional teeth that extended along the full length of the jaw; the most anterior ones being much reduced." In addition to the characters of the dentition, Mr. Gilmore notes specializations in the reduction of the cervical intercentra to a simple free element in *B. marshi*, the median fusion of the clavicles, and the presence of a sixth digit in the anterior limb.

In the comparison of *Baptanodon* with the European *Ophthalmosaurus*, the two are shown to be remarkably similar. Distinguishing characters are found in the presence in *Baptanodon* of a sixth digit in the anterior limb, the uniform biconcave cupping of the anterior cervical centra, and the fusion of the clavicles. The two types are, however, very close together, as similar as one could reasonably expect to find species so widely separated geographically.

In the light of what is actually known, the relation of *Baptanodon* to the later Triassic forms of America seems still far from close. *Shastasaurus*, the youngest known Triassic genus, is at least in limb structure highly specialized along a line almost diametrically opposite that taken by *Baptanodon*. Unless a closer connection with the late Triassic forms of this continent can be discovered, we must continue to look upon *Baptanodon* as probably a Jurassic immigrant from the old world. The close relationship to the European *Ophthalmosaurus* is additional evidence in favor of the suggestion that *Baptanodon* was a Jurassic importation. In this connection it is interesting to note that Frass\* has recently described a vertebra which he believes to represent the genus *Ophthalmosaurus*, from the Jurassic of North-east Greenland.

JOHN C. MERRIAM.

3. *Cambrian Faunas of India*; by CHARLES D. WALCOTT. Proc. U. S. National Museum, xxxix, 1905, pp. 1-106.—This paper is the result of a preliminary study of the Cambrian material collected by Mr. Blackwelder, as a member of the Carnegie Institution of Washington Expedition to China, under the leadership of Mr. Bailey Willis. Previous to this expedition, Kayser,

\* E. Frass, Meddelelser om Grönland, xxix, p. 283.

Dames, and Bergeron had described 21 species, which are now increased by Walcott to 172 forms, of which 118 are trilobites. "The large fauna discovered in the reconnaissance made by Messrs. Willis and Blackwelder is an indication of the richness of the Cambrian faunas of eastern Asia, and of the great results that may be expected when systematic, thorough exploration and collecting are undertaken."

Almost the entire Cambrian seems to be represented here, and rests on the Tai Shan complex. The Lower Cambrian in the Man To formation has 12 species, and as the trilobite *Redlichia* is the diagnostic fossil, seemingly being a direct descendant of *Olenellus*, we are led to infer that the lower portion of the Lower Cambrian, as known in America, may be absent in China. The Middle Cambrian in the Chang Hsia formation is the richest in fossils. Another and higher member of this division is the Ku San shale, with a small fauna; followed by the Upper Cambrian in the Chao Mi Tien limestone, having another considerable faunal development.

"The fauna of the Ku San shale includes species of *Damesella*, *Dorypyge*, and genera that are typical of the Middle Cambrian fauna, while the fauna of the Chao Mi Tien limestone . . . is more nearly related to that of the Upper Cambrian of North America and northwestern Europe."

Walcott's lists clearly indicate that the Middle Cambrian of China is directly connected with that of America, a fact long ago noted by Dames, and recently more decidedly by Frech. The Upper Cambrian also has the American impress, while the Lower Cambrian is Asiatic in character.

The oldest known cephalopod is described here as *Cyrtoceras cambria*. The structure, as described, is that of *Cyrtoceras*, but one would rather have looked for *Piloceras* or *Endoceras*-like forms in the Cambrian. Brachiopods, gastropods, and especially trilobites make up the faunas, while not a single bivalve is here recorded. Of new genera—all trilobites—there are *Dorypygella*, *Damesella*, *Anomocarella*, *Pagodia*, and *Shantungia*. c. s.

4. *The Cambrian Fauna of India*; by CHARLES D. WALCOTT. Proc. Washington Acad. Sci., vii, 1905, pp. 251-256.—The writer here reviews the small Cambrian fauna of India first described by Waagen; this has also been referred to the Silurian and Carboniferous. Walcott concludes: "In the absence of any fossils clearly indicating the *Olenellus* fauna I think it unwise at present to assume any other age for the fossiliferous Cambrian beds than Middle Cambrian." c. s.

5. *Catalogue of the Type Specimens of Fossil Invertebrates in the Department of Geology, U. S. National Museum*; by CHARLES SCHUCHERT, assisted by W. H. DALL, T. W. STANTON, and R. S. BASSLER. Bull. U. S. National Museum, No. 53, Part I, 1905, pp. i-v, 1-704.—This is an alphabetic catalogue of the type and illustrated fossil invertebrates in this museum, previous to 1905. It records 11,490 specimens of 6,100 species. Within

the past few years, three similar catalogues have been published. The first one, by the American Museum of Natural History, New York City; the second, by the New York State Museum, Albany, New York, and now the one cited above. The last, however, records the largest number of species, and is an indication of the great amount of paleontological work done at Washington.

6. *Graptolites of New York. Part I, Graptolites of the Lower Beds*; by R. RUEDEMANN. N. Y. State Mus., Mem. 7, 1904 (distributed March 1905), pp. 457-803, pls. 1-17.—This very valuable monograph had its origin in stratigraphic work by the author, in the slate belt of eastern New York. The book is of the greatest importance, not only to paleontologists and paleogeographers, but as well to the stratigrapher of the older Paleozoic formations. In fact, the work is so valuable that no review could bring out its many excellent points, unless it were of great length, for which space is not at our disposal. In this monograph are treated the late Cambrian and early Ordovician graptolites of America, the species and genera not only being described and illustrated, but also their structure, morphology, reproduction, development, mode of existence, phylogeny, and systematic position, as well as the bearing of these organisms on the stratigraphy and paleogeography of Ordovician time. c. s.

7. *Mesozoic Plants from Korea*; by H. YABE. Jour. College Sci., Imperial University, Tokyo, Japan, 1905, pp. 1-59, pls. i-iv.—Here are described 21 species, 3 of which are new. Filices are the most prevalent, being represented by 11 species.

“It is quite evident that the flora is Jurassic, for neither typically Rhaetic or Cretaceous forms are found in it.”

“On the whole, so far as evidence goes, the writer has little hesitation in announcing the contemporaneity of the Naktong flora of Korea with that of the Japanese Tetori series [about Malm and Dogger], the affinity of the former to those of the corresponding age in Siberia, China, India and California being apparently more distant.” c. s.

8. *Palaeontologia Universalis*.—Early in September of the present year, there appeared the first fascicle of the second series of this important publication. Ninety-four species are now re-described and refigured and brought up to date. c. s.

9. *Ninth Annual Report of the Geological Commission, Dept. of Agriculture, Cape of Good Hope, for 1904*. Pp. 181 with numerous maps and figures. Cape Town, 1905.—This report contains the description of the detailed survey of several districts in the Colony of the Cape of Good Hope; thus adding valuable detail to the general works on South African geology which have recently appeared. J. B.

10. *Rock Cleavage*; by CHARLES KENNETH LEITH. Bulletin 239, U. S. Geol. Surv., 1905, pp. 216. 27 pls.—As noted by Dr. C. W. Hayes in the letter of transmittal, “The paper embodies the results of a very careful and laborious investigation of facts concerning rock cleavage and a discussion of their theoretical

significance. Its publication will place the subject of rock cleavage in a much more satisfactory shape and be of material assistance to all structural geologists." The writer divides secondary or induced cleavage into *flow-cleavage* and *fracture-cleavage*. The first is considered as depending upon a parallel arrangement of mineral particles and is shown to be developed by rock flowage, the cleavage, as held by Van Hise and Hoskins, developing at any instant normal to the greatest pressure, but the final direction of cleavage may be inclined to the direction of greatest pressure which has produced the deformation. Fracture-cleavage on the other hand is considered as not dependent upon a parallel arrangement of mineral constituents and as arising in a plane of shear in the outer zones of the earth's crust. The writer follows the inductive method of studying the facts in the field and laboratory and pointing out their significance.

J. B.

11. *Experiments on Schistosity and Slaty Cleavage*; by GEORGE F. BECKER. Bulletin 241, U. S. Geol. Surv., 1904, pp. 34, 7 pls.—This bulletin embraces the results of valuable experiments upon clay and ceresin in a "scission engine" of the author's invention in order to test disputed theories of cleavage. The results show, according to Dr. Becker, that in these cases the cleavage arose on planes of shear and not in the planes subjected to greatest pressure. This is in conformity with the author's conclusions published ten years previously and these are regarded by him as establishing his contention that all cleavage is to be regarded as arising in planes of shear. As noted in the previous review, Professor Leith grants the occurrence of this form of cleavage, but regards it as only of partial application to the natural phenomena and distinct from the more common flow-cleavage. Leith also differs from Dr. Becker in the interpretation of the experiments, regarding the results as due to flow-cleavage.

J. B.

12. *Die Alpen im Eiszeitalter*; von Dr. ALBRECHT PENCK, Professor an der Universität Wien und Dr. EDUARD BRÜCKNER, Professor an der Universität Bern. Part 6, pp. 545-656, 1904; Part 7, pp. 657-784. Leipzig, 1905.—These two parts continue the discussion of the Alps in the Glacial Period, and it is expected that the series will be completed upon the issuance of one more part. The volumes are well illustrated by profiles, maps, and photographs, and the names of the authors are a guarantee as to the quality of the work.

The subjects discussed in part 6 include the glacial history of the Reuss, Aar and Rhone valleys, the physiographic features and the nature of the interglacial plant remains. Part 7 deals chiefly with the French and southern Alps and discusses the paleolithic finds and their relation to the glacial and interglacial times. This work is of the utmost interest to anthropologists as well as to glacialists and physiographers and will rank for many years as a standard contribution to the Quaternary history of Central Europe.

J. B.

13. *Structural and Field Geology*; by JAMES GEIKIE. Pp. xx + 435, 56 page plates, 142 text illustrations. New York, 1905 (D. Van Nostrand Co.).—This volume opens by describing the rock-making minerals, also the rocks and fossils in so far as they are related to structural geology. Following this are several chapters on the rock structures, such as stratification, faults, mode of occurrence of eruptive rocks and of ore formations. A third part deals with the principles of geological surveying and the economic aspects of geological structure. The work is made very attractive by clear typography, appropriate subdivisions, and by the number and excellence of the illustrations, taken almost entirely from the British Isles, the plates being photographic reproductions. In photographing the rock-types, however, there is a tendency to unnaturally heighten the color contrasts.

Within the limits indicated by the title this is an excellent treatise, the subject matter being well arranged and classified. The chief value is for its outdoor application, the student finding here a good discussion of field methods and a full description of the structures which he is to look for and identify. The subordination of the dynamical to the structural side results necessarily in the causal relations of earth structures and their interpretation from being made prominent. The ultimate significances of the geological facts are thus not well brought out, and as these are the highest significances they should not be lost sight of in geological instruction. However, as the volume does not profess to cover this side of the subject, it should not be urged as a criticism but should merely be called to the attention of educators as not supplying the whole of the inorganic side of the science. As a text-book presenting an excellent account of the facts and field methods upon which geological conclusions are based, it is of value to all students of pure or applied geology.

J. B.

14. *The Clays and Clay Industries of Connecticut*; by GERALD FRANCIS LOUGHLIN. Bulletin No. 4 Connecticut Geol. and Natural History Survey. Hartford, Conn. 121 pp., 13 maps and plates. 1905.—This report gives first the geographical distribution of the Connecticut clays, followed by a discussion on the origin of clays in general and the geological history of the Connecticut clays in particular. It is shown that they were laid down in quiet waters fronting the continental glacier toward the close of the glacial period. The gravels, sands and clays give indications of water levels at 180, 120 and 80 feet above the present level of the sea. The writer ascribes the highest of these to damming by fragments of ice still lingering to the south, as the highest indication of shore lines to the south is only 120 feet above sea level. But in view of Fuller's recent paper on the Geology of Fisher's Island,\* the reviewer suggests as not improbable that these high-level gravels and clays may mark a

\* Bull. Geol. Soc. Amer., vol. xvi, pp. 367-390, 1905.

deepest stage of the Champlain submergence. If so they are of considerable scientific importance as serving to correlate the stages of ice retreat with the several stages of the Champlain subsidence within the New England states. Having given the geographical distribution and origin of the Connecticut clays, the subject is taken up of the chemistry of clays, the physical properties of clays and their commercial classification. Following this the composition, properties and adaptabilities of the Connecticut clays are given in detail. The lacustrine and estuarine clays, embracing the bulk of the clay deposits, while suited for the best quality of common red brick at low expense, are limited in their uses by high percentage of iron and extremely low fusing point. Part II treats of the clay industries of Connecticut.

The bulletin is well written throughout and is adapted to the comprehension of the intelligent but untechnical reader. The limited time and money appropriated for this work prevent it from being a final study of the subject, as noted in the introduction. Yet the results are of very considerable value, and by calling attention to one of the resources of the state which is, at present, but poorly developed, may ultimately yield a return in industry many times the comparatively small expenditure required for this report.

J. B.

15. *Geology of Western Ore Deposits*; by ARTHUR LAKES, late Professor of Geology at the Colorado School of Mines. 438 pp., 300 illustrations. Denver, Col. (The Kendrick Book and Stationery Co.)—This volume is not written for the specialist but for the intelligent miner or other person interested in the subject of western ore deposits. Introductory chapters review the rock-making minerals, the ore minerals, and the features of structural and dynamical geology connected with ore deposits. A glossary and index serve a useful purpose. The principles of ore deposition and various types of ore deposits are treated, the examples being chiefly drawn from Colorado, with which state the writer is most familiar, but the mining districts of the other western states and of Alaska are also briefly reviewed, and the distinctive features indicated.

J. B.

16. *The Delavan Lobe of the Lake Michigan Glacier of the Wisconsin Stage of Glaciation and Associated Phenomena*; by WILLIAM C. ALDEN. 106 pp., 15 plates. Washington, 1904. Professional Paper No. 34, U. S. G. S.—The author presents in this paper the detailed results of several seasons field work in the southeastern part of Wisconsin on a small tributary lobe of the Lake Michigan glacier. The points of chief interest lie in the proof, based on interlobate phenomena, of the contemporaneity of the Lake Michigan, Delavan, and Green Bay ice lobes and the simultaneous withdrawal of the two latter from their terminal moraines; and in the application to the deposits in this field of the criteria for the determination of the age relationships of the Wisconsin and pre-Wisconsin drift.

A large number of analyses of the drift of this region were made and its lithological character carefully determined therefrom. The interesting result is found that 87 per cent of the material is of local derivation, thus indicating a subglacial origin. The surface boulders are predominantly foreign and therefore probably englacially transported. No essential lithological difference was noted between the drift of terminal moraines, outwash, ground moraines and drumlins.

I. B.

17. *Platinum in Black Sands from Placer Mines*, DAVID T. DAY. —A circular sent out by U. S. Geological Survey in March, 1905, to some 8,000 placer miners, chiefly in the United States, has thus far brought in some 828 samples of black sands; these are largely from the western states and territories, but also from British Columbia, Central America and Mexico. Of these samples, 195 specimens were assayed for gold and platinum with the result of finding platinum in 72 of the specimens. Of these 72, 17 showed only a trace and 14 an amount equal to two ounces or more per ton of concentrate. A sample from Junction City mining district, Trinity Co., Cal., showed 25.8 oz.; one from Oroville, Butte Co., Cal., showed 27.45; and one from Riddle, Douglas Co., Oregon, 128.73 oz. In addition to these tests, 190 samples were examined as to the minerals present with interesting results; polycrase is noted in sands from Idaho Co., Idaho, and columbite and tantalite from Shoshone Co. Field work has also been carried on in the collection and examination of sands of various placer deposits, as also from bars in the Columbia river; important results may be anticipated from this thorough work.

18. *CASSITERITE, a new cleavage, or perhaps parting law*; by WILLIAM E. HIDDEN (communicated).—Preliminary announcement is hereby made of my late observation, at the Ross Tin Mine, near Gaffneys, S. C., of a new cleavage (or "parting") in cassiterite. This new cleavage is very common, almost perfect and is parallel to  $e$  (101, 1- $i$ ). Very imperfect cleavages parallel to  $s$  (111, 1) and  $m$  (110, 1) were also noticed, those with  $s$  being most common.

Measurements of  $e \wedge \acute{e}$  (cleavage surfaces), with hand goniometer, gave  $133\frac{1}{2}^\circ$ , while the required angle is  $133^\circ 32'$ . Faces of the new cleavage up to four inches long and over two inches wide were noticed, remarkably smooth and flat. They are very characteristic of the locality. Twins parallel to the well-known twinning plane ( $e$ , 101) were not uncommon. Some of these were elongated with the  $s$  planes, making what seem to be prismatic planes, similar to sphene, etc. This new tin locality is already credited with having produced about forty tons of cassiterite (yielding over 70% metallic tin) and gives good promise for the future. The associated minerals are albite, microcline (?), amphibole, quartz, biotite, menaccanite, rutile, garnet and probably scapolite, monazite and eudialyte.



## III. MISCELLANEOUS SCIENTIFIC INTELLIGENCE.

1. *Harvard College Observatory*.—Recent publications include the following :

ANNALS, Vol. LIII, No. V, Phoebe, the ninth Satellite of Saturn ; by WILLIAM H. PICKERING.

No. VI, Investigation of the Orbit of Phoebe ; by FRANK E. ROSS.

No. VII, Second Supplement to Catalogue of Variable Stars.

No. VIII, Martian Meteorology ; by WILLIAM H. PICKERING.

No. IX, The ninth and tenth Satellites of Saturn ; by WILLIAM H. PICKERING.

Vol. LVI, No. III. The Spectrum of Nova Persei, No. 2.

CIRCULARS. No. 93, The 24-inch Reflecting Telescope.

No. 94, Variability of Eunomia (15).

No. 95, Brightness of Jupiter's Satellites.

No. 96, 843 new variable Stars in the small Magellanic Cloud.

No. 97, Bruce Photographs of Planets.

No. 98, Stars having peculiar Spectra.

No. 99, A probable new Star, RS Ophiuchi.

No. 100, Variable Stars in the Clusters Messier 3 and Messier 5.

No. 101, Positions of Ocello (475) during 1904.

No. 102, Positions of Phoebe in May, 1904.

No. 103, Positions of Ocello (475) during 1905.

No. 104, H 1174. A new Algol Variable, 035727.

2. *Publications of the Cincinnati Observatory*. No. 15, *Catalogue of 4280 Stars for the Epoch 1900* ; by JERMAIN G. PORTER, Director. 100 pp. Cincinnati, 1905 (University of Cincinnati).—The stars included in this volume are all those of Piazzi's catalogue which were north of the equator in 1800 except those contained in the Berlin Jahrbuch and eighteen of the Pleiades group ; stars observed by Piazzi, but not given in his catalogue, are also included.

3. *Report of the Director of the Yerkes Observatory, University of Chicago* ; by Professor GEORGE E. HALE. 1, for the period July 1, 1899 to June 30, 1902, pp. 32. 2, for the period July 1, 1902 to June 30, 1904, 8 pp.—These reports, though presented in very concise form, give a clear summary of the various lines of important work carried on at the Yerkes Observatory during the five years from 1899 to 1904.

4. *Carnegie Institution of Washington*.—Recent publications from the Carnegie Institution include the following :

No. 8. Bibliographical Index of North American Fungi ; by WILLIAM G. FARLOW. Vol. I, Part I, Abrothallus to Badhamia, Pp. xxxv, 312, 8vo. Washington, Sept. 1, 1905.

No. 25, Evolution, Racial and Habitudinal ; by Rev. JOHN T. GULICK. Pp. xii, 269, 8vo. Washington, August, 1905.

No. 27. Bacteria in Relation to Plant Diseases ; by ERWIN F. SMITH, in charge of Laboratory of Plant Pathology, Bureau of Plant Industry, U. S. Department of Agriculture. Volume I,

Methods of work and general literature of Bacteriology exclusive of Plant Diseases. Pp. xii, 285, 4to, with 31 plates and 146 text-figures. Washington, September, 1905.

5. *Annual Report of the Board of Regents of the Smithsonian Institution, showing the operations, expenditures and condition of the Institution for the year ending June 30, 1904.* Pp. lxxix, 804, with numerous plates and text-figures.—The advance report of the Secretary, Professor S. P. Langley, was noticed in the number for March, on page 261. The complete volume now issued contains this administrative report, occupying the first one hundred pages, and also following a general appendix, pp. 109–791, containing, as usual, a series of articles. These give brief accounts of important scientific discoveries, also reports of investigations made by the workers connected with the Institution, and some more extended papers on special subjects of interest to the correspondents of the Institution. The volume closes with biographical notices of Sir George G. Stokes, Professor von Zittel and Professor Karl Gegenbauer.

6. *Catalogue of the Collection of Birds' Eggs in the British Museum of Natural History.* Volume IV, *Carinatae (Passeriformes continued)*; by EUGENE W. OATES assisted by Capt. SAVILLE G. REID. Pp. xviii, 352, with 14 colored plates. London, 1905.—This fourth volume of the British Museum Catalogue of Birds' Eggs corresponds with the fourth volume of Dr. Bowdler Sharpe's Hand-list of Birds. The number of species included is 620, represented by 14,917 specimens.

7. *Bibliotheca Zoologica II. Verzeichniss der Schriften über Zoologie welche in den periodischen Werken enthalten und vom Jahre 1861–1880 selbständig erschienen sind;* bearbeitet von Dr. O. TASCHENBERG. Siebzehnte Lieferung.—The sixth volume of this comprehensive work is completed with the present part. Like the parts immediately preceding, it is devoted to the twenty-second section of the entire field, that of Paleozoology, which it brings to a close. The volume, title page, dedication, and table of contents are also included.

#### OBITUARY.

BARON FERDINAND VON RICHTHOFEN died on October 7th, at the age of seventy-two years.

PROFESSOR LEO ERRERA, Professor of Botany in the University of Brussels, died on August 1, at the age of forty-seven years.

Mr. G. B. BUCKTON, F.R.S., the English Entomologist, died on September 26, at the age of eighty-eight years.

M. ELISÉE RECLUS, the eminent French geographer, died in July last in his seventy-sixth year.

# MERELY A REMINDER

THIS PAGE is occupied by us merely as a reminder that the only concern in America which can supply you with

SPECIMENS IN ALL DEPARTMENTS OF NATURAL HISTORY  
(Except Botany and Entomology)

IS

## Ward's Natural Science Establishment

To our old friends, the leading museums, colleges, educators and private collectors of the world, we are continually offering new things, some of which will be announced at the bottom of this page, from time to time. We endeavor to always remember you with our latest circulars; if you have failed to receive these recently, a line from you will bring them by return mail.

To those who have not formerly dealt with us,—our establishment was founded in 1862, and incorporated in 1890 as a stock company with a paid-up capital of \$125,000. We occupy a frontage of 250 feet facing the University of Rochester, and are known from the Yukon to the Ganges as the largest institution in the world dealing in Natural History Specimens. For over forty years we have made it our sole business to collect, prepare and sell these, individually or in collections. Quality rather than extreme cheapness is our aim, and we have spared no expense to maintain a high standard and a standing in scientific circles. We pay no commissions, but deal direct with our customers, and sell at list prices only. We offer school collections as low as \$5 and have made one cabinet costing over \$100,000 (Field Columbian Museum, Chicago), and seventeen others ranging from \$10,000 to \$70,000. In numerous instances we have built a large public museum complete at one stroke. Our catalogues, over twenty in number, are not mere price-lists, but are valuable as reference works, and have even been used as text-books in academies and colleges. A small charge is made for these, except to our regular customers or teachers intending to purchase; a list will be sent upon request. We also issue free circulars in all departments, and shall be glad to place your address on our mailing list.

### OUR DEPARTMENTS.

*Mineralogy* (Minerals, Rocks, Crystal Models, Meteorites, etc.).  
*Geology* (Phenomenal Series, Relief Maps, Geological Models).  
*Palaeontology* (Fossils, Casts of Celebrated Fossils, Wall Charts, etc.).  
*Archaeology and Ethnology* (Specimens, Models, Casts of Monuments).  
*Invertebrates* (Shells, Echinoderms, Corals, etc.; Biological Supplies).  
*Zoology* (Mounted Skins and Skeletons, Custom Work in Taxidermy).  
*Human Anatomy* (Human Skeletons, and Anatomical Models of all kinds).

### SPECIAL ANNOUNCEMENT FOR THIS MONTH.

We have cut into slabs and polished a fine boulder of the **ORBICULAR GABBRO** from Dehesa, California, described in this Journal Sept., 1904. Details in regard to size of slabs and prices will be sent on request.

---

## Ward's Natural Science Establishment,

76-104 COLLEGE AVENUE, ROCHESTER, N. Y.

## CONTENTS.

	Page
ART. XXXVI.—A New Niobrara Toxochelys; by G. R. WIELAND. (With Plate X.) .....	325
XXXVII.—Contributions to the Geology of New Hampshire. I. Geology of the Belknap Mountains; by L. V. PIRSSON and H. S. WASHINGTON. (With Plate XI.)	344
XXXVIII.—The Fauna of the Chazy Limestone; by P. E. RAYMOND .....	353
XXXIX.—The Mechanical Properties of Catgut Musical Strings; by J. R. BENTON .....	383
XL.—Use of the Rotating Cathode for the Estimation of Cadmium taken as the Chloride; by C. P. FLORA .....	392

### SCIENTIFIC INTELLIGENCE.

*Chemistry and Physics.*—Formation of Ozone by Ultra-violet Light, FISCHER and BRAEMER: New Reagent for Nickel, TSCHUGAEFF, 397.—Electrolytic Dissociation Theory with some of its Applications: Soils and Fertilizers: Engineering Chemistry, 398.—Text-book of Chemical Arithmetic: Text-book of Physiological Chemistry for Students of Medicine: Formation of Helium from the Radium Emanation, 399.—Blondlot's "Emission pesante": Diffusion of Nascent Hydrogen through Iron, A. WINKLEMANN, 400.—Landolt-Börnstein Physikalisch-chemische Tabellen, 401.

*Geology and Mineralogy.*—United States Geological Survey, 402.—Osteology of Baptonodon, C. W. GILMORE, 403.—Cambrian Fauna of India, C. D. WALCOTT, 404.—Catalogue of Type-Specimens of Fossil Invertebrates in the Department of Geology, U. S. National Museum, 405.—Graptolites of New York; Part I, Graptolites of the Lower Beds, R. RUEDEMANN: Mesozoic Plants from Korea, H. YABE: Paleontologia Universalis: Ninth Annual Report of the Geological Commission, Dept. of Agriculture, Cape of Good Hope, for 1904: Rock Cleavage, C. K. LEITH, 406.—Experiments on Schistosity and Slaty Cleavage, G. F. BECKER: Die Alpen im Eiszeitalter, 407.—Structural and Field Geology, J. GEIKIE: Clays and Clay Industry of Connecticut, G. F. LOUGHLIN, 408.—Geology of Western Ore Deposits: Delavan Lobe of the Lake Michigan Glacier, etc., 409.—Platinum in Black Sands from Placer Mines, D. T. DAY: Cassiterite, W. E. HIDDEN, 410.

*Miscellaneous Scientific Intelligence.*—Harvard College Observatory: Publications of the Cincinnati Observatory: Report of Director of the Yerkes Observatory, Univ. of Chicago: Carnegie Institution of Washington, 411.—Annual Report Board of Regents Smithsonian Institution: Catalogue of Collection of Birds' Eggs in the British Museum of Natural History: Bibliotheca Zoologica II, 412.

*Obituary.*—Baron FERDINAND VON RICHTHOFEN, Professor LEO ERRERA, Mr. G. B. BUCKTON, M. ELISÉE RECLUS, 412.

### TEN-VOLUME INDEX.

An *extra number*, containing a full Index to volumes XI to XX of the Fourth Series, will be ready in December. Sent only to those who specially order it. Price one dollar.

Established by BENJAMIN SILLIMAN in 1818.

THE  
AMERICAN  
JOURNAL OF SCIENCE.

EDITOR: EDWARD S. DANA.

ASSOCIATE EDITORS

PROFESSORS GEORGE L. GOODALE, JOHN TROWBRIDGE,  
W. G. FARLOW AND WM. M. DAVIS, OF CAMBRIDGE,

PROFESSORS ADDISON E. VERRILL, HORACE L. WELLS,  
L. V. PIRSSON AND H. E. GREGORY, OF NEW HAVEN,

PROFESSOR GEORGE F. BARKER, OF PHILADELPHIA,

PROFESSOR HENRY S. WILLIAMS, OF ITHACA,

PROFESSOR JOSEPH S. AMES, OF BALTIMORE,

MR. J. S. DILLER, OF WASHINGTON.

FOURTH SERIES

VOL. XX—[WHOLE NUMBER, CLXX.]

No. 120—DECEMBER, 1905.

WITH PLATES XII—XV.

NEW HAVEN, CONNECTICUT.

1905

THE TUTTLE, MOREHOUSE & TAYLOR CO., PRINTERS, 123 TEMPLE STREET.

Published monthly. Six dollars per year, in advance. \$6.40 to countries in the Postal Union. Remittances should be made either by money orders, registered letters, or bank checks (preferably on New York banks).

193868

# RARE MINERALS IN TON LOTS

Correspondence solicited with miners or consumers of the ores of

**Molybdenum**

**Tantalum**

**Thorium**

**Titanium**

**Tungsten**

**Uranium**

**Vanadium**

**Yttrium**

**Zirconium**

and other rare metals. Offers from producers should be accompanied by samples.

---

## SYSTEMATIC COLLECTIONS OF TYPICAL SPECIMENS

In sets of twenty-five up to fifteen hundred specimens. Prices \$5.00 upwards per set, the average price for students' specimens being about twenty cents. We have supplied the leading institutions for thirty years, having lately completed a single order for over 60,000 specimens. Our material is the accepted standard both as to correct labeling and high quality.

**Free Collection Catalog**, containing lists and illustrations of General Mineral Collections, Series of Ores for Prospectors, Sets of Crystals, Series illustrating Hardness and other Physical Characters of Minerals, with Price List of Laboratory Material and Individual Specimens.

---

## FOOTE MINERAL CO.,

Established 1876, by Dr. A. E. Foote.

**W. M. FOOTE, Manager.**

DEALERS IN

**MINERAL SPECIMENS AND COMMERCIAL RARE MINERALS,**

1317 Arch Street, Philadelphia.

THE

# AMERICAN JOURNAL OF SCIENCE

[FOURTH SERIES.]

ART. XLI.—*Two New Ceratopsia from the Laramie of Converse County, Wyoming*; by J. B. HATCHER. (With Plates XII, XIII.)

[From a Monograph on the Ceratopsia by J. B. Hatcher. Published by permission of the Director of the U. S. Geological Survey.]

*Editorial note.*—In the course of his extensive study of the Laramie Ceratopsia contained in the U. S. National Museum and in that of Yale University, Mr. Hatcher discovered two forms which were new to science. These he described in the above mentioned monograph, giving to the first, an undoubted *Triceratops*, a new specific name, while for the second specimen, which represents a new genus as well as species, no name was suggested by the author. The duty of naming this form devolves therefore upon the editor. The generic name *Dicera-**tops* is suggested by the lack of a nasal horn, while the specific name *hatcheri* will serve to commemorate Mr. Hatcher's work in connection with this remarkable type.

In view of the recent discoveries among these most interesting forms, it has been deemed advisable to publish these descriptions at the present time without waiting for the publication of the monograph.—RICHARD S. LULL.

*Triceratops brevicornus* sp. nov.

Plate XII, Figures 1 and 2.

Type No. 1834, Yale Museum.

*Char. Specific:* Supraorbital horn cores short and stout, not much compressed, nearly circular in cross-section. Nasal horn core short and stout with the anterior border vertical instead of being directed upward and forward at an angle of 30 degrees. Vertical and longitudinal diameters of lateral temporal foramen nearly equal. Orbit irregularly elliptical in outline with the longer axis running from above downward and forward. Postfrontal fontanelle open even in old individuals.

*The type*, No. 1834, Yale Museum, of the present species consists of a nearly perfect skull with lower jaw and a com-

plete series of presacral vertebræ, together with a number of ribs more or less complete, and portions of the pelvis, including a portion of the right ilium and a nearly complete pubis. The vertebral series lay in position with the vertebræ interlocked by their zygapophyses from the axis to the last dorsal, though portions of some of the vertebræ had weathered away when found. Behind the posterior dorsal, impressions of the centra of the first two sacrals were preserved in the hard sandstone in which the skeleton was imbedded.

*Locality.*—The skeleton was discovered by Mr. W. H. Utterback, and the exact locality was some three miles above the mouth of Lightning Creek and about one and a half miles south of that stream, in Converse County, Wyoming. The horizon was near the summit of the Laramie, and the specimen was collected by the present writer assisted by Messrs. W. H. Utterback, A. L. Sullins, and T. A. Bostwick. When discovered the skeleton lay imbedded in a hard sandstone concretion and was much shattered and weathered about the pelvic region. None of the limb bones and no part of the tail were recovered.

#### *The Skull.*

The extremely rugose nature of the skull together with the closed condition of the sutures, many of which are almost or entirely obliterated, make it certain that the type of the present species pertained to an old individual.

*The Cranium.*—The chief distinctive features of the cranium are as follows: The supraorbital horn cores are unusually short and stout, especially at the base. They are less compressed and more nearly circular in cross-section than in most other species. The nasal horn is short and very stout with the antero-posterior diameter much exceeding the transverse. Its anterior border is directed upward in a line perpendicular with the longer axis of the skull instead of forward and upward at an angle of about thirty degrees to that axis as in the type of *T. prorsus*. The lachrymal foramen, as in *T. serratus*, lies between the maxillary and the nasal, but in the present species its anterior half is entirely enclosed by the maxillary, that bone sending upward a short process alongside the premaxillary process and forming the anterior one-half of the superior border of the foramen. The orbit is elliptical in outline with the longer diameter inclined backward from the perpendicular at an angle of about ten degrees. The lateral temporal fossa is triangular in outline, its respective borders describing nearly an equilateral triangle, the fore and aft diameter only slightly exceeding the vertical. The rostral bone is heavy and very deeply excavated beneath. The epijugal is rather



acutely pointed and regularly triangular in cross-section. The infratemporal arch, as in *T. serratus*, is formed by the quadrate with overlapping processes from the jugal and squamosal, that from the latter element occupying a slightly more elevated position in the type of the present species than in that of *T. serratus*. The exoccipital process extends distally beyond the quadrate and projects as a small angular process. There are six exoccipitals, borne wholly on the squamosal, and at least three more between the last of these and the single median one situated at the median parietal region. Though the frill is not sufficiently perfect in this region to determine the number of epoccipitals with accuracy, there cannot be fewer than nineteen. The postfrontal fontanelle is large and circular in outline. The median longitudinal crest of the parietals is well defined and bears the usual rugosities. Near the apex the right horn core has been worn into a peculiar form by the action of wind, sand and water while it protruded from the sandstone concretion in which it was found prior to its discovery. The palatial view shows no characters essentially different from those of other species of this genus. In the region of the supraoccipitals and parietals the sutures are so obliterated by age and obscured by distortion and crushing that it is quite impossible to determine their nature.

*The Lower Jaw.*—The lower jaws with the predentary were in position and in a splendid state of preservation. The predentary is rather longer than is common. On the superior surface of the mandibular fossa near the anterior end two large foramina pierce the wall and pass upward toward the dental chamber. The splenial is very broad posteriorly and entirely encloses the mandibular fossa, except at the opening of the internal mandibular foramen. The coronoid process is low and stout and superiorly it is produced forward into a broad and somewhat decurved projection. At its greatest expansion the superior border of the splenial covers over for a short distance the series of dental foramina on the inner side of the dentary. The principal characters of the skull are well shown in Plate XII, figures 1 and 2.

*The Vertebrae.*—The vertebrae will be fully described in that portion of the monograph relating to the osteology of the genus *Triceratops*.

*Principal Measurements of Type of T. brevicornus (No. 1834, Y. M.).*

Greatest length of skull .....	1652 <sup>mm</sup>
Greatest breadth of frill .....	1120
Expanse of jugal .....	600

Expanse of frontal region at anterior border of orbits . . .	357 <sup>mm</sup>
Greatest diameter of orbit . . . . .	168
Least " " " . . . . .	120
Fore and aft diameter of lateral temporal fossa . . . . .	105
Vertical " " " " " " . . . . .	85
Distance from posterior border of orbit to posterior border of frill . . . . .	840
Thickness of postfrontal behind orbit . . . . .	130
Least antero-posterior diameter of horn core immediately above orbit . . . . .	175
Antero-posterior diameter of horn core, six inches above orbit . . . . .	117
Transverse diameter of horn core immediately above orbit	140
Transverse diameter of horn core, six inches above orbit	97
Greatest length of squamosal . . . . .	870
" breadth of " . . . . .	433
Length of parietals along median line . . . . .	712
Distance between squamosal sutures at posterior border of frill . . . . .	874
Distance between squamosal sutures at junction with post- frontals . . . . .	330
Distance from anterior border of orbit to posterior border of nasal opening . . . . .	228
Distance between orbit and lateral temporal foramen . . .	142
Distance between lateral and supra-temporal foramina . . .	285
Distance from lateral temporal foramen to posterior border of squamosal . . . . .	705
Distance from occipital condyle to posterior margin of crest . . . . .	650
Distance from occipital condyle to interior border of rostr- tral . . . . .	975
Distance from posterior border of anterior nares to ante- rior border of rostral . . . . .	525
Distance from postfrontal foramen to extremity of nasal horn . . . . .	750
Greatest expanse of exoccipital processes . . . . .	550
Distance from inferior border of orbit to bottom of jugal	343
Diameter of occipital condyle . . . . .	88
Distance from mid-frontal region to apex of supraorbital horn . . . . .	500
Length of splenial . . . . .	503
" " prementary . . . . .	255
Greatest breadth of prementary . . . . .	142
Combined length of dentary and prementary . . . . .	681
" " " " " articular . . . . .	620
Total length of presacral vertebral series . . . . .	2290
" " " dorsal series . . . . .	1490

*Diceratops hatcheri* Lull, gen. et sp. nov.

Plate XIII, Figures 3 and 4.

Mr. Hatcher's description is as follows :

“*Char. Generic:* Nasal horn core absent. Squamosal bones pierced by large fenestrae, while smaller ones penetrate the parietals. The inferior border of the squamosal lacks a quadrate notch.

Type No. 2412, U. S. National Museum.

“*Char. Specific:* Supraorbital horn cores short, robust, and nearly circular in cross-section at base, erect and but slightly curved. Orbits project in front of the horns, the frontal region lying between the horns being concave. Exoccipital processes slender and widely expanded.

“*The type*, No. 2412, of the U. S. National Museum, consists of a skull without the lower jaw. The posterior portion of the frill is somewhat weathered but the specimen appears to have suffered comparatively little from crushing.

“*Locality:* The specimen was found in a hard sandstone concretion about three miles southwest of the mouth of Lightning Creek, Converse County, Wyoming. When found the concretion in which the shell was imbedded had entirely weathered out of the surrounding sandstone and stood at an altitude of five or six feet above the ground, firmly attached beneath to another concretion. The skull stood on its nose with the frill pointing upward.

“*The Skull:* The chief distinctive features of the skull are as follows: The supraorbital horn cores are comparatively short, robust, and nearly circular in cross-section at the base instead of compressed, as in most other species. They rise more directly upward than in other species and are only slightly curved. The orbits also occupy a position more anterior than that seen in other species; the anterior borders of the horn cores rise from about the middle of the superior borders of the orbits so that the orbits project well in front of the horns. The frontal region between the orbits is concave. The exoccipital processes are rather slender and widely expanded.

“The nasals terminate anteriorly in a rounded rugosity not developed into anything approaching a nasal horn and resembling that of the type of *Triceratops obtusus*. The rostral bone is small and firmly coössified with the premaxillaries. The latter are elongate but not deep. The maxillaries are massive and the lachrymal foramen is elongate and below and considerably forward of the orbit. The jugal is broad distally and firmly coössified with the epijugal. The lateral temporal fossa is nearly as deep vertically as longitudinally. The squa-

mosal is elongate, and just posterior to the quadrate groove it is pierced by a large fenestra. The antero-inferior angle is little produced and there is no quadrate notch, the inferior border in this region describing widely an open concavity. The parietals are broad and thin and, on either side of the median line about 235<sup>mm</sup> in front of the posterior border, there is an elongated fenestra with a longitudinal diameter of 150<sup>mm</sup> and a greatest transverse diameter of 52<sup>mm</sup>. This fenestra is completely enclosed on the right side, but on the left the parietal is injured in this region. In the drawings it has been restored from the right side. The supra-temporal fossa is elongate. There is a single median postfrontal fontanelle as in *Triceratops*, but posteriorly this gives origin to two deep channels, one on either side. These run backward along the surface of the parietal and terminate in two small circular fontanelles, conditions very similar to those which obtain in *Torosaurus*.

*Measurements of the type.*

“ Distance from anterior end of rostral to posterior of squamosal .....	1990 <sup>mm</sup>
Distance from anterior end of rostral to anterior of orbits .....	845
“ “ inferior border of orbit to lower end of jugal .....	363
“ “ posterior border of nasal opening to extremity of beak .....	614
Distance from posterior border of orbit to posterior surface of horn core .....	175
Distance between anterior borders of orbits .....	340
Circumference of supraorbital horn cores at base .....	610
“ “ “ “ mm. above orbit .....	340
Vertical diameter of orbits .....	165
Antero-posterior diameter of orbits .....	125”

[*Note.*—This genus is most nearly allied to *Triceratops* and is distinguished therefrom mainly by the much smaller rostral bone; by the absence of a nasal horn, which in all species save *T. obtusus* is fairly well developed; by the very erect, short, robust, supraorbital horn cores which seem to take their origin much further back with relation to the orbit; by the concavity of the frontal region between the orbits and by the peculiar form of the postfrontal fontanelle. The general proportions of the skull resemble *Triceratops* rather than the contemporary genus *Torosaurus*, in which the great frill so preponderates over the comparatively abbreviated facial region. The parietals resemble those of *Triceratops* except for the presence of the small fenestrae on either side of the median line.

The squamosals differ from those of *Triceratops* in the conformation of the lower border, which lacks the quadrate notch, and in the presence of the unique fenestrae.

1

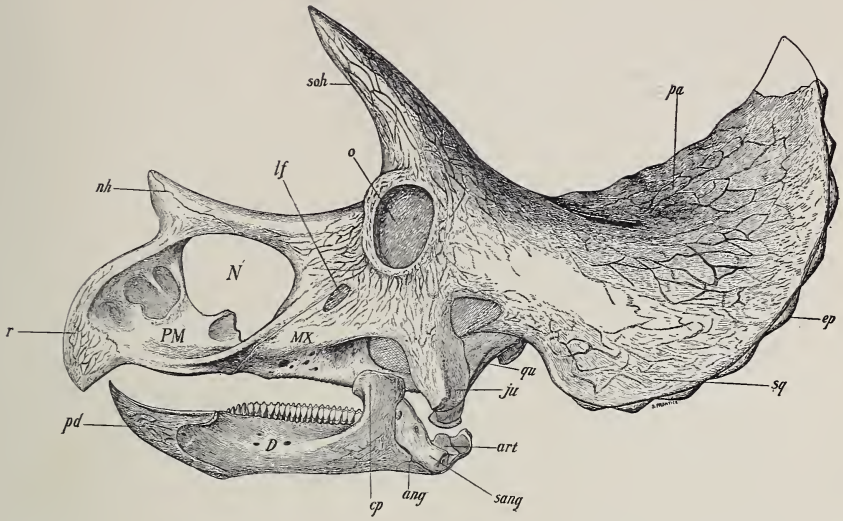

2

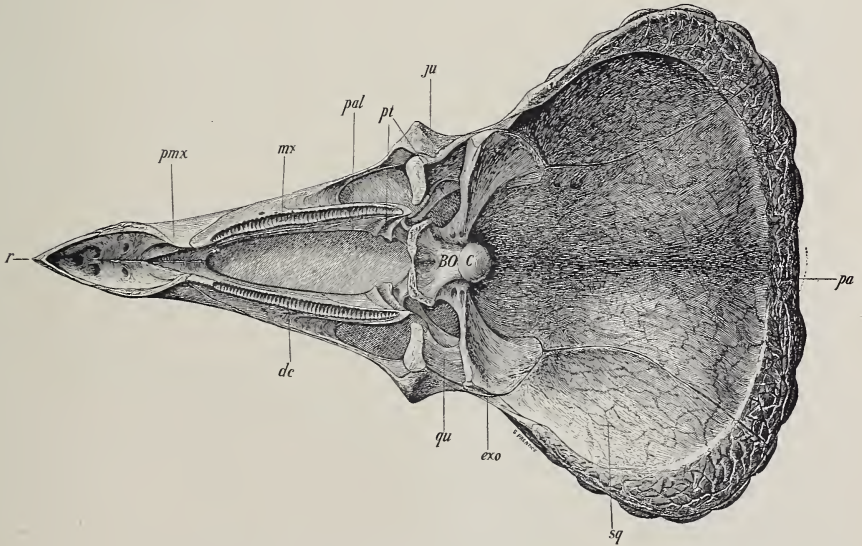

*Triceratops brevicornus* Hatcher, one-sixteenth natural size.



1

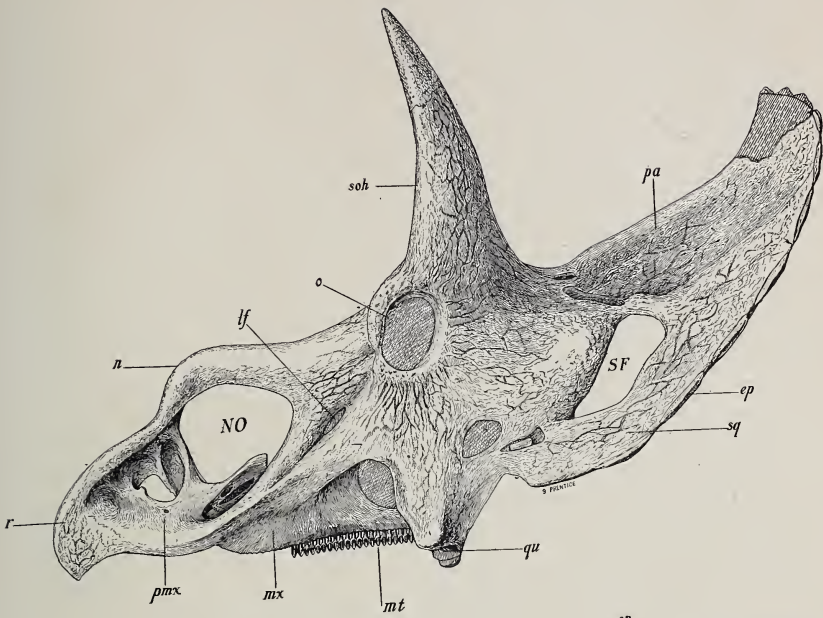

2

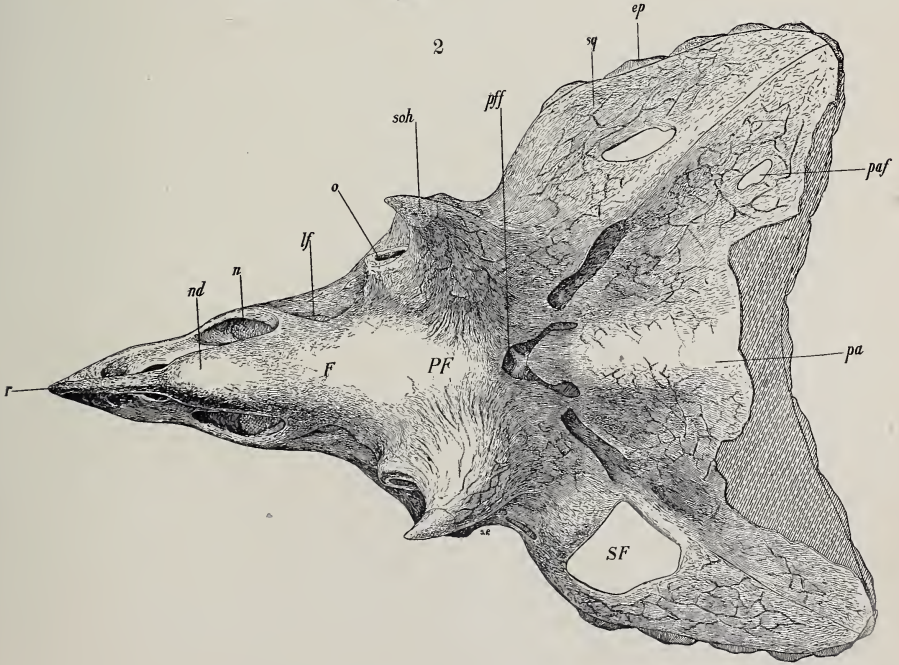

*Diceratops hatcheri* Lull, one-sixteenth natural size.





Aside from the general proportions of the skull, *Diceratops* and *Torosaurus* differ in the presence in the former of separately ossified epoccipital bones around the margin of the frill. These ossicles are apparently entirely lacking in *Torosaurus*. The two genera agree in the possession of parietal fenestræ though these are evidently not homogenous. They also agree in the form of the postfrontal fontanelle.

While I believe *Diceratops* to be a valid genus, I am not inclined to lay the stress upon the parietal and squamosal fenestræ which Hatcher does, as they may possibly be pathologic. Those of the squamosal bones, which are found in no other form among *Ceratopsia*, are not of the same size, while only one is known in the parietals for the sufficient reason that the bone is broken away on the left side where the fenestra would come if present, and it is quite possible that it may never have existed.

There is preserved in the Museum at Yale University a *Clasaurus* scapula with a clean cut foramen through it with perfectly healed edges. This foramen is not present in the other scapula from the same individual and Professor Marsh used to say that the perforation was caused by a *Triceratops* horn. This certainly seems suggestive of the manner in which the *Diceratops* fenestræ may have arisen.

RICHARD S. LULL.

Amherst, Mass.]

#### DESCRIPTION OF PLATES.

##### PLATE XII.

Skull of the type specimen of *Triceratops brevicornus* Hatcher. No. 1834, Yale University Museum. One-sixteenth natural size.

FIGURE 1.—Lateral view. *ang*, angular; *art*, articular; *ep*, coronoid process; *D*, dentary; *ep*, epoccipital; *ju*, jugal; *lf*, lachrymal foramen; *mx*, maxillary; *no*, nasal opening; *nh*, nasal horn core; *o*, orbit; *pa*, parietal; *pd*, predentary; *pmx*, premaxillary; *qu*, quadrate; *r*, rostral bone; *sang*, surangular; *sq*, squamosal; *soh*, supraorbital horn core.

FIGURE 2.—Palatal view. *dc*, dental channel; *exo*, exoccipital; *ju*, jugal; *mx*, maxillary; *pa*, parietal; *pal*, palatine; *pmx*, premaxillary; *pt*, pterygoid; *qu*, quadrate; *r*, rostral bone; *sq*, squamosal; *BO*, basioccipital; *C*, occipital condyle.

##### PLATE XIII.

Type skull of *Diceratops hatcheri* Lull. No. 2412, U. S. National Museum. One-sixteenth natural size.

FIGURE 1.—Lateral view. *ep*, epoccipital; *lf*, lachrymal foramen; *mt*, maxillary teeth; *mx*, maxillary; *n*, nasal; *NO*, nasal opening; *o*, orbit; *pa*, parietal; *pmx*, premaxillary; *qu*, quadrate; *r*, rostral bone; *SF*, squamosal fenestra; *soh*, supraorbital horn core.

FIGURE 2.—Dorsal view. *ep*, epoccipital; *lf*, lachrymal foramen; *n*, nasal opening; *o*, orbit; *pa*, parietal; *paf*, parietal fenestra; *pf*, postfrontal fontanelle; *r*, rostral bone; *SF*, squamosal fenestra; *sq*, squamosal; *soh*, supraorbital horn core.

ART. XLII—*Restoration of the Horned Dinosaur Diceratops*; by RICHARD S. LULL. (With Plate XIV.)

THE new genus and species described by Hatcher in the preceding article represents perhaps the most bizarre and grotesque form among all the race of horned dinosaurs, and the author has attempted an interpretation for the purpose of emphasizing the features wherein this animal differed from any of its allies.

Diceratops comes from the Laramie of Converse County, Wyoming, and while contemporaneous with Triceratops and Torosaurus it is probably as late in geological time as any of the species of either genus, and may be said to represent the culmination of at least one phylum of the Ceratopsia. Diceratops differs from Torosaurus in the proportions of the skull, for in the latter genus the frill is relatively huge as contrasted with the abbreviated facial region. In this Diceratops and Triceratops agree, and it is quite evident that there is a genetic relationship between these genera, while Torosaurus represents a totally distinct phylum.

Perhaps the most notable point of distinction between Triceratops and Diceratops is the presence of a fairly well developed nasal horn in the former while in the latter genus it is lacking, a feature which in the author's mind represents the culmination of specialization.

The earliest known Ceratopsia are the Judith River types, characterized by an incomplete frill, by rudimentary horns above the eyes, and by a very well developed, generally erect or backwardly curved nasal horn.

The supraorbital horns are progressive structures while the nasal horn is retrogressive, and during the lapse of time between the Judith River and Laramie periods, when the marine Bearpaw shales and Fox Hills sandstones were laid down, the Ceratopsia underwent a remarkable though unrecorded evolution, for when they again come into view in the Laramie the armament is reversed, in that the great temporal horns are by far the larger and more efficient weapons, and the diminishing nasal horn, while supplementing the others in the various species of Triceratops and Torosaurus, is vestigial in the form under discussion.

This change of armament was necessarily accompanied by a change in the method of attack, for while the Judith River types probably used the one horn much as the rhinoceros does, with an upward thrust, Triceratops seems to have charged with lowered head, the small forwardly directed nasal and the larger

supraorbital horns meeting the enemy at the same moment of impact. The frill now becomes of greater protective value instead of affording leverage merely for the muscles of the neck.

*Diceratops* exhibits the extreme of development of this style of warfare, for the supraorbital horns are the sole aggressive weapons while the widely expanded frill served admirably to withstand the shock of the adversary's horns. We have here a precise analogy with the knight of old tilting with his spear and shield.

The skull of *Diceratops* shows the horns to be very erect, much more so than in *Triceratops*, so that the head would have to be carried much lower in charging than in the latter genus and the horns through relatively short are extremely powerful. I have indicated a callosity, the last vestige of a horn, over the nasals, for they still remain very highly arched and evidently bore some of the impact of the adversary's blow. The eyes were set in deep thick-rimmed sockets which look directly outward, evidently limiting the forward range of vision, but affording ample protection to these highly necessary organs.

If one will turn to Hatcher's figure of the *Diceratops* skull (Plate XIII, figures 1 and 2), he will notice in the frill several apertures which Hatcher has called "fenestræ." Two of these are through the squamosal portion of the frill, one on either side, and one through the parietal.\* They are irregular in size and in position, and while the Judith River types and *Torosaurus* among the Laramie forms have *parietal* fenestræ, they are large and symmetrical, and there is no instance of *squamosal* fenestræ in any known genus of Ceratopsia. If the author's conception of the final function of the frill is correct, there would be no reason for the development of apertures through it, which would only tend to weaken it and mar its usefulness. It seems vastly more probable that these are "old dints of deep wounds" received in combat. None of them, not even the great one on the left, were necessarily fatal, as they all seem to be through the free portion of the frill, and, while the bone was destroyed, the horny or leathery integument may have grown again over the gap as indicated in the model. The edge of the apertures are healed, showing that the animal lived for some time after the injuries were received.

I have represented the gape of the mouth with much less

\* Mr. C. W. Gilmore, who prepared the type specimen of *Diceratops*, is by no means sure of the "parietal fenestra." There was no bone adhering to the matrix at that point so he left the opening through the frill for want of evidence to the contrary. The bone forming the margin of the left squamosal aperture is decidedly pathologic.

backward extent than in other restorations of Ceratopsia. Here we cannot be guided by the form of the mouth in existing reptiles, for none living have the same feeding habits as these dinosaurs. Here the mouth may properly be divided into an anterior prehensile portion, the turtle-like beak, and a posterior masticating portion, the dental armature. In herbivorous mammals the gape only includes the prehensile and never the masticating portion, because of the necessity of muscular cheeks to retain the food in the mouth. The Ceratopsia had a dental apparatus which chopped the food into short lengths, and the pieces, falling outside of the lower jaw, would have been lost had the gape extended backward beyond the beginning of the tooth series.

Massachusetts Agricultural College, Amherst.

1



2



Restoration of *Diceratops hatcheri* Lull, from a model by the author.

The upper figure is that of the front view of the model with the muzzle somewhat depressed.



ART. XLIII.—*Triassic System in New Mexico*; by CHARLES R. KEYES.

THE "Red Beds" of the Southwest, from central Kansas to the Grand Canyon, have long defied every attempt to determine their geological age, and to satisfactorily settle even the larger problems connected with their stratigraphy. In Kansas, in Oklahoma, in Texas, and on through New Mexico and Arizona to Utah, these formations have for more than half a century remained a puzzle. Those who have had to give some attention to the Red Beds have, in the absence of abundant characteristic fossils, considered the entire sequence either Triassic in age or (so-called Permian) Carboniferous.

Since the making of extensive examinations of the Red Beds formations over broad areas in New Mexico and the adjoining states during the past few years, it has been found that there are a number of important general features that have either not received the attention they deserve, or have escaped notice altogether. When two years ago I made the statement\* concerning the Kansas section, that after seeing at close range the Red Beds of New Mexico sufficient data had been obtained to clearly demonstrate that their stratigraphy could not be unraveled on the basis of the Kansas scheme, the separation of the Red Beds into their component parts was then beginning to resolve itself into a satisfactory reality.

The Red Beds do not form the homogeneous succession that they have been generally regarded as doing. Lithologically they are broadly divisible into two easily distinguishable parts. There is a large portion of the entire section composed of heavy argillaceous shales and clayey sandstones usually of deep red colors, rather uniform throughout, with much gypsum intercalated and disseminated, and with saline shales abounding. The upper part consists of light, sandy shales chiefly, with some heavy sandstones; the colors, while prevalently reds, are quite varied; gypsum and saline shales are present only sparingly. The plane separating the two parts of the Red Beds section, as thus defined, is, when once recognized, a conspicuous one.

In eastern New Mexico, in the Canadian and Pecos valleys, around the northern and western margins of the Llano Estacado, there is at the base of the upper one of the two terranes a well marked conglomerate that has been widely traced. Unconformable relationships exist between this and the strata beneath. In western Texas, Drake† and Cummins have also well established these facts.

\* American Geologist, vol. xxxii, pp. 218-223, 1903.

† Texas Geol. Sur., Third Ann. Rept., p. 227, 1892.

In western New Mexico, in the Zuni uplift, there exist, as was first shown by Dutton,\* similar conditions, except that the evidences of unconformities have not as yet been noted, and in fact no attempt has yet been made to look carefully for them. Between the two lithologically different parts of the Zuni section of the Red Beds there also exists an important conglomerate which the author just mentioned correlates with Powell's Shinarump conglomerate of the Grand Canyon, and which is considered the base of the Triassic of that district.

According to all available data, derived from the biologic contents, which at best are rather meager, the stratigraphic relationships, and lithologic characters, there is a lower portion of the Red Beds belonging to the so-called Permian (Carboniferous) and an upper portion which appears to be Triassic in age.

One great difficulty which has been encountered in the consideration of the Red Beds in the southwestern United States has been the existence of a great erosion interval during Early Cretaceous times when the Red Beds suffered severely from planing off during the period when they constituted part of a vast land area. This fact has only lately been fully appreciated,† and its full significance grasped.

The three general sections of western, central and eastern New Mexico may be paralleled as in the subjoined table:

GENERAL RED BEDS SECTIONS IN NEW MEXICO.

Western Section.	Central Section.	Eastern Section.
Dakota sandstones..	Dakota ss.	Dakota sandstones..
Wanting .....	Wanting	Comanche sandstones 300
Zuni shales .....	Wanting	Pyramid shales .....
1200	Wanting	100
Wingate sandstones 800	Wanting	Amarillo sandstones 200
Shinarump shales .. 1500	Wanting	Endee shales..... 300
Moencopie shales... 500	Wanting	Cimarron shales..... 1000
Madera limestones .	Madera li.	Not exposed.....

The geographic distribution of the Triassic beds presents some special points of interest. East of the Rio Grande the Carboniferous part of the Red Beds probably greatly predominates over the Triassic portion. West of that stream the latter no doubt has very much the larger section. Owing to extensive erosion that took place over the Red Beds district, at least throughout much of what is now New Mexico, before the deposition of the Dakota sandstone, a large portion of the Triassic portion must have been removed. It may be that part of this erosion took place just prior to Triassic times, as the conglomerate bed 500 feet above the base of the Red Beds

\* U. S. Geol. Sur., Sixth Ann. Rept., p. 135, 1886.

† This Journal (4), vol. xviii, pp. 360-362, 1904.



section in the Zuni region and in the middle of the section in eastern New Mexico would indicate.

In the Canadian valley, at the eastern border of New Mexico, the sediments of the Triassic system are well represented at the top of the Red Beds section. Farther westward, where the Rio Pecos cuts the Glorietta escarpment, Newberry distinguished both Triassic and Permian (Cimarron) plant remains.

Around the entire escarpment of the Llano Estacado, or Staked Plains, in eastern New Mexico and western Texas, embracing an area of over 50,000 square miles, the Triassic beds are more or less well exposed. The New Mexico portion of this belt is 300 miles long. The greater part of the Red Beds section seen in the Canadian and Pecos valleys is of Triassic age. Only in the bottom of these valleys is the Carboniferous part of the Red Beds found.

It now seems quite likely that within the boundaries of Kansas none of the Red Beds section can be considered as being of Triassic age. Early Cretaceous erosion, which bevelled off the Red Beds, appears to have removed the Triassic strata altogether east of the New Mexico line and north of the Canadian river. The youngest layers of the Early Cretaceous (Comanche series) in overlapping northward on the old, even, erosion-surface, now appear to rest, in southern Kansas, on the lower part only of the Red Beds.

West of the Rio Grande, in north-central New Mexico, along the Chama river, at the locality known as Abiquiu, Newberry and Cope regarded a very thick Triassic section to be represented. Around the Zuni mountains is an important belt of Triassic strata, which according to Dutton are more than 3500 feet in thickness.

As detailed mapping of the region goes on, the beds which have been considered as belonging to the Triassic system will be found to have a very much wider geographic distribution than is at present known, and many new localities will doubtless be discovered in which these strata are well represented.

In eastern New Mexico the basal plane of the Triassic appears to be well established at the bottom of a well-marked conglomeratic sandstone which separates the lower, dark red, clayey Red Beds from the upper, light reddish, sandy portions. At the base of this conglomerate there are abundant evidences of unconformable relationships between the two parts of the section.

These relationships are well displayed along the northern magnificent escarpment of the Llano Estacado, which forms the south side of the Canadian valley. Drake,\* who has traced the formation along the entire length of this great wall, and

\* Texas Geol. Sur., Third Ann. Rept., p. 229, 1892.

who has examined its details rather carefully, says regarding the character of this unconformity: "The slight difference in dip, and sudden change in lithological character of the Triassic beds from the Permian, point conclusively to a break in the sedimentation of the two formations. At some localities the Triassic beds are overlain by Cretaceous, but generally by Tertiary material. The Cretaceous escarpments or buttes resting on the Triassic beds are often two hundred feet thick, and mostly limestone. The denuding forces that for an immense length of time were cutting these Cretaceous rocks back towards their present limits must have carried away a great deal of the Triassic before it was covered by Tertiary. The strata thus enclosed between two unconformable beds must of necessity vary in thickness, and so we find it varying from a few feet to nearly four hundred feet. Even in localities close together the beds vary considerably in thickness. The average, however, will probably reach two hundred feet."

Of the appearance of the two formations a short distance east of the New Mexico line the same writer\* observes: "The contact between the Dockum beds and the underlying Permian is clearly marked. Both the color and lithological characteristics of the two formations bear a striking contrast. The Permian is a bright red argillaceous sand, slightly shaly, though sometimes massive, is characteristic for stratification planes, and below the top forty feet is interstratified with massive and fibrous gypsum, the gypsum becoming more abundant toward the base of the section exposed. The Dockum beds, arenaceous clays, in contact are a yellowish purple or a yellowish red, sometimes decidedly yellowish. The bedding is usually uniform and lacks the stratification planes so characteristic of the Permian. The contrast between the formations along their contact is so great that the contact may be located as far as the eye can see stratification planes in the freshly eroded outcropping bed, or as far as it can distinguish sharply contrasting colors."

The upper limiting horizon of the Triassic section is well defined. In the east, around the Llano Estacado in the Canadian and Pecos valleys, the superjacent formations are beds of the Comanche series of the Early Cretaceous. A little farther to the westward the massive Dakota sandstone of the Mid-Cretaceous age is the capping member. West of the Rio Grande there comes in between the Wingate division of the Triassic Red Beds and the undoubted Dakota sandstone a series of red and white shaly sandstones having a thickness of 1,200 feet, the exact age of which is at present not definitely determined. This formation is thought to belong to the Tri-

\* *Ibid.*, p. 241.

assic system. It is not impossible that it is Jurassic or Cretaceous in age. It is the beginning of a great formation which extends a long distance to the northwestward into Arizona, western Colorado and Utah and which has been regarded as representing the Jurassic period.

East of the Rio Grande a very marked plane of unconformity separates the Dakota sandstone from the Red Beds beneath. This break in sedimentation represents a profound erosion period, to which more detailed reference is made in another place

The stratigraphic extent of the Triassic strata in eastern New Mexico embraces about 500 feet of the general geological section. In the west the vertical measurement is very much greater. Dutton places it at 3,500 feet.

As regards correlation of the Triassic formations, that portion of the Red Beds which has been regarded as of Triassic age may be compared, on the one hand, with the cognate beds of the Texas section, and on the other with the enormous thicknesses of Triassic strata in Arizona, Utah and Colorado.

The standard section of the Triassic in New Mexico should be considered typically developed in the northwestern portion of the region, where the section is most complete and most extensive. In comparing this sequence with the Texas, Oklahoma and Kansas sections of the Red Beds there are presented some difficulties of an unusual kind. The planing off of the folded Paleozoics including the Red Beds in great part, during the erosion interval which existed in the eastern New Mexico region just before the deposition of the Dakota sandstone, removed a very large portion of the formation.

As at present understood, the general relationships of the Carboniferous part of the Red Beds, the Triassic Red Beds, and the associated formations are best indicated by diagram as given below.

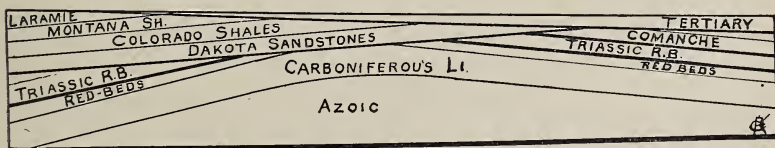

FIG. 1.—Relationships of the Triassic Formations in the southern Rocky Mountains.

The cross-section traverses New Mexico in a nearly east and west direction, passing through the Cerro Tucumcari and the Zuni mountains.

Owing to mountain-making movements which took place in the region in the latest Carboniferous or in Early Cretaceous

times, or possibly in both, the Paleozoic formations and Triassic beds were bowed up, somewhat folded and faulted and then eroded off as a land surface. When Mid-Cretaceous (basal part of "Upper") beds were laid down, they were deposited largely on this old land surface worn out on the bevelled edges of the older formations.

In the east there are shown marked unconformable relationships not only between the Cimarron Red Beds and the Triassic Red Beds, but between the latter and the Comanche series, between the last mentioned and the Dakota sandstone series, and between all of these and the Tertiary formations.

In central New Mexico, the Dakota series rests directly on the Madera limestones of the Carboniferous. The Red Beds of both the Cimarron series and the series of the Triassic have been entirely removed through Early Cretaceous erosion. The Comanche series, which had been constantly encroaching upon the old land area from the beginning to the end of its period of deposition, did not reach this far. In consequence the Mid-Cretaceous sandstones (Dakota) were deposited directly upon the Carboniferous limestones (Madera).

In the west the sequence was very much as it was in the east, except that the Early Cretaceous appears to be entirely missing, the Triassic section very much thicker, and the Cimarron section very much reduced.

It is a singular fact that the tripartite character of the Triassic sections in the west has a triple counterpart in the east. No direct connection between the two sections has been actually traced in this field, for in central New Mexico a wide gap exists.

Comparing the eastern section with the sections of the adjoining portions of Texas, this agreement is very close. The entire Triassic section is there called the Dockum beds. As already stated, it is not believed that any portion of the Red Beds of Kansas are represented by the Triassic formations of New Mexico.

In the Zuni uplift, where the Triassic beds are so well displayed, they come up from beneath the vast field of Cretaceous sandstones. The sequence between the so-called Permian Red Beds and the Dakota sandstones of the Cretaceous is very thick. The data upon which the geological age has been determined have been already given. Dutton, who a quarter of a century ago had perhaps given the subject more attention than anyone else, was unable to satisfactorily separate the two parts. He says that the "Triassic system of New Mexico cannot be correlated so easily with its cognate beds in southern Utah and the Grand Canyon district as the Carboniferous and Permian. In the former region it has yielded but few fossils, while in the

latter it has yielded none at all. We have here as well as there only an arbitrary provisional horizon for its base, and we are if possible still more uncertain where to assign its summit. The paleontological doctors disagree, and who therefore shall decide? It all hinges upon the question whether the Jurassic system has any representatives in this region. If not, then the summit of the Trias can be established at once. But if the upper portion of the enormous series of sandstones and gypsum beds which lies between the Shinarump conglomerate and the lower Cretaceous sandstone is Jurassic, the problem must wait for a solution.”\*

Of the Zuni section of the Triassic system it may be that only the lower portion is represented east of the Rio Grande. The upper part of this section has been regarded as belonging to the Jurassic age; but until fuller data are obtained it does not appear advisable to recognize the Jurassic system in this part of the country. For the present, at least, all of this part of the sequence will be considered as a portion of the Triassic succession.

New Mexico School of Mines,  
Socorro, New Mexico.

\* U. S. Geol. Sur., 6th Ann. Rept., p. 135, 1886.

ART. XLIV.—*Structure of the Upper Cretaceous Turtles of New Jersey*.\* *Agomphus*; by G. R. WIELAND.

THE genus *Agomphus* was first proposed by Cope for the reception of Leidy's *Emys firmus* and *Adocus petrosus* and *Adocus turgidus*,† all of which are based on very fragmentary and scanty remains from the Upper Cretaceous marl beds of New Jersey, indicating a genus of heavy shelled turtles next related to *Adocus*. Two of these original types, *A. petrosus* and *A. turgidus*, are now conserved in the Cope Collections in the American Museum of Natural History, where the writer has been extended the courtesy of seeing them, together with the allied *Adocus pectoralis* Cope. An additional type from the Tertiary of Georgia, *Amphiemys oxysternum*,‡ is no doubt correctly referred to *Agomphus*, but has not been accessible. Since the brief descriptions unaccompanied by figures were given by Cope, the only addition to the very meager knowledge of *Agomphus* was made by Baur,§ who briefly noted in addition to the close relationship to *Adocus* and inclusion in the Adocidæ as next related to the existing Central American Dermatemydidæ, the peculiar costiform processes and the interesting fact that *Agomphus* includes forms with relatively the heaviest carapace and plastron known. These latter facts were doubtless based on the specimens of the Marsh Collection obtained about the same time as the Leidy and Cope material, but never formally described or further mentioned although now found to make possible a complete description of the structure of the carapace and plastron, and to include at least two new species and a toptype as follows:

*Agomphus tardus* Wieland (sp. nov.). (Figures 1-7.)

By far the best specimen of the Marsh collection referable to the genus *Agomphus* is that numbered 774 (Accession No. 323), and now made the type of the new species *A. tardus*. This fine fossil was obtained from the Pemberton marl pits at Birmingham, Burlington County, New Jersey, in 1869. It is of especial interest as affording the structural characters of the

\* The first paper of this series, on *Adocus*, *Osteopygis*, and *Propleura*, appeared in this Journal, vol. xvii (pp. 112-132, pl. I-IX), Feb. 1904, and the second on *Lytoloma*, in vol. xviii (pp. 183-196, pl. V-VIII), Sept., 1904.

† The description of these forms under the generic name *Emys* appears on pages 125-8 of Cope's Synopsis of the Extinct Batrachia, Reptilia and Aves of North America. Philadelphia, August, 1869.—*Agomphus* in Suppl't, 1871.

‡ On a New Species of Adocidæ from the Tertiary of Georgia; by E. D. Cope. Proc. American Phil. Soc., vol. xvii, July, 1877, pp. 82-4.

§ Notes on some little known American Tortoises (on pp. 429 and 430), Proc. Acad. of Natural Sciences, Philadelphia, 1891 (pp. 411-430).

shell of another genus of a well represented Upper Cretaceous to Tertiary family, the Adocidæ, and as being relatively the heaviest and most massive turtle shell yet discovered. Although originally a perfect fossil with suturally united carapace and plastron, only thirteen complete and five incomplete elements of the carapace, together with the hyo- and hypoplastron, have escaped the accidents of discovery and collection. Of the imperfect parts but four are diagnostic as to form, whence the recovered elements that are wholly determinative virtually number

1

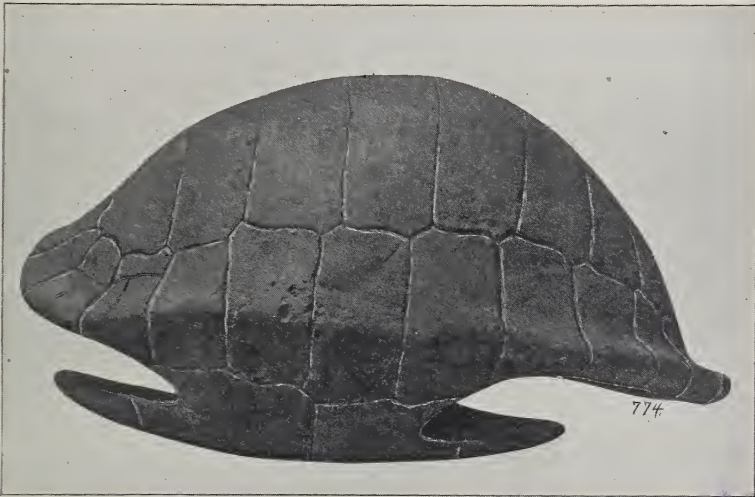

FIGURE 1.—*Agomphus tardus* Wieland (sp. nov.). Carapace and plastron of type specimen\* with the missing portions restored in the estimated natural size and position. Actual length of carapace 33<sup>cm</sup>. Elements present indicated in the succeeding figures 2-5.

but nineteen, or exactly one-third of the original fifty-seven elements of which the carapace and plastron was composed. These recovered elements of grayish to dark, marl green color, are however perfectly fossilized, uncrushed, disarticulated, and without crumbling or breaking of the sutural faces. Moreover they are by a rare and noteworthy chance so distributed as to clearly outline the missing elements and make possible a restoration by the Museum preparateur, Mr. Gibb, and the writer, which it is confidently believed by both will be found essen-

\* Elements present: nuchal (incomplete), 2d and 5th neurals, left 1st and 2d pleurals, right 4th and 5th pleurals (incomplete), right 6th and 7th pleurals, left 2d marginal, left 5th and 6th marginals (incomplete), left 10th and 11th marginals, right 8th-11th marginals, the left hyo- and the right hypoplastron.

tially correct as to form and size whenever a complete individual of this species is fortunately discovered. A side view of the restoration is shown in figure 1, this being perhaps the best view; for it was not found possible to bring all the elements into an absolutely symmetrical position, although they are virtually so indicated in the supplementary drawings, figures 2-6.

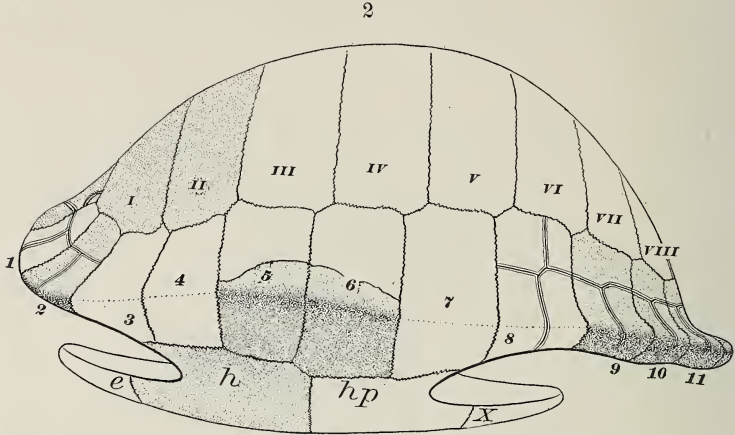

FIGURE 2.—*Agomphus tardus*. Left lateral view of the carapace of the type with elements present stippled (except 9th marginal). I-VIII and 1-11, the respective pleuralia and marginalia; e, epiplastron; h, hyoplastron; hp, hypoplastron; x, xiphiplastron. [Actual length of specimen 53<sup>cm</sup>.]

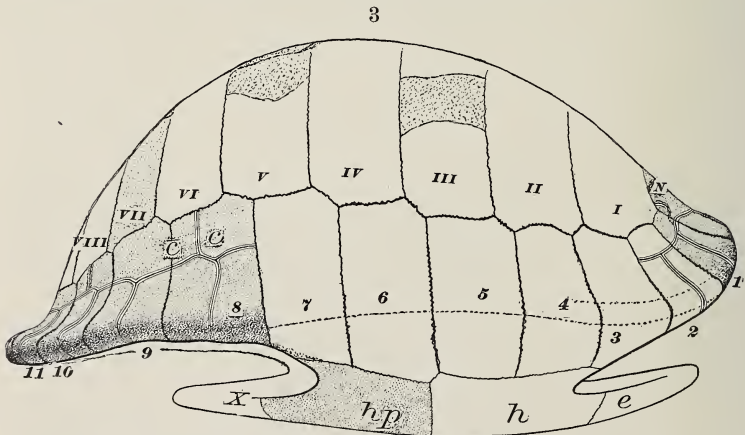

FIGURE 3.—*Agomphus tardus*. Right lateral view of carapace and plastron. Drawn from type with elements present stippled. N, nuchal; c, c, 3rd and 4th costalia. Other lettering as in the preceding figure.



As clearly shown in the figures, *A. tardus* was of robust oval form with marked depth over the inguinal region, and a distinct flanging of the nuchal region which gives the carapace a very symmetrical to ornate appearance. The rib capitulæ are diminutive. The medium-sized and heavy plastron without fontanelles is strongly interlocked by suture with the marginals, and the axillary buttress extends forward to the 3d, the inguinal buttress, back to the 8th marginal, as in *Adocus*.

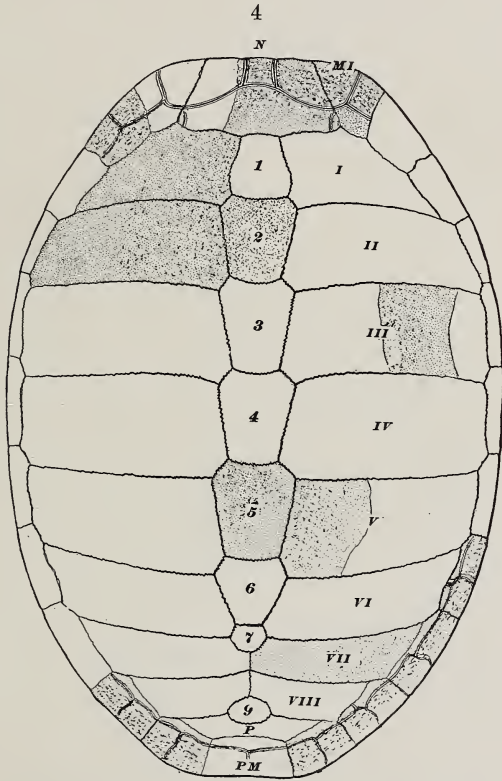

FIGURE 4.—*Agomphus tardus*. Dorsal view of the carapace. Drawn from the type with parts actually present stippled. *N*, nuchal; *MI*, 1st marginal. *I-7* and *9*, the neuralia; *P*, pygal; *PM*, pygal marginal; *I-VIII*, the respective pleuralia.

The most curious single feature is the complete perforation of the first marginals by the costiform processes of the nuchal. (Cf. figure 6.) The outlines of the transverse sections of the several elements as shown in the supplementary figures 6 and 7, in connection with the measurements may render more

detailed description of the form of the individual elements unnecessary. These figures show in particular the enormous thickness of the elements of the plastron, which is especially heavy near to the hypo-xiphiplastral suture. There was, however, no trace of fusion with the pubes. The hornshields are for the greater part indicated by narrow sulci not accentuated in the nuchal region as in *Adocus*, with the inner

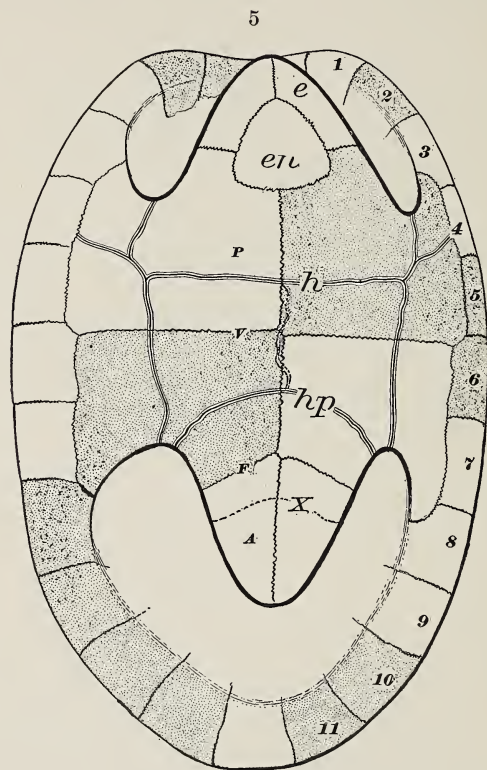

FIGURE 5.—*Agomphus tardus*. Plastral view drawn from the type. *P*, pectoral, *V*, ventral, *F*, femoral, and *A*, anal hornshields; *en*, entoplastron. Other letters and numbers as in figures 2 and 3.

borders of the marginalia, as is especially to be noted, not traversing the pleuralia as in that genus, but continuing below the pleuro-marginal sutures all round the carapace from the nuchal to the pygal region.

*Specific Relationships.*—The forms with which *Agomphus tardus* is to be compared are (1) *A. (Emys) firmus* (Leidy),

(2) *A. petrosus* Cope, (3) *A. turgidus* Cope, (4) *A. (Amphiemys) oxysternum* Cope, and (5) *Adocus (Pleurosternum) pectoralis* Cope,—all of which are either slightly or not illustrated and difficultly accessible or little known types, based on fragmentary materials of barely diagnostic value beyond family or generic limits. It appears, however, that in comparison with *Agomphus tardus* (sp. nov.), *A. (Emys) firmus* was a larger form with a shell relatively but not nearly so extremely heavy; that *A. turgidus* Cope (as further described from the Marsh Cotype No. 900), is a small turtle of about the same size as *A. tardus* with minor differences of form and horn-

6

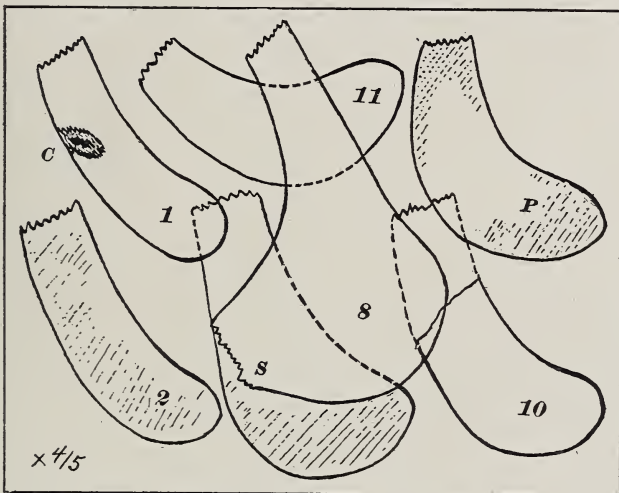

FIGURE 6.—*Agomphus tardus* (type).  $\times \frac{4}{5}$ . Outlines of the anterior sutural faces or transverse sections of the 1st, 2d, 8th, 10th, 11th and pygal marginals.—C, pit in anterior face of the right 1st marginal for the reception of the costiform process of the nuchal, which entirely perforates this marginal; S, sutural face for union of 8th marginal with the hypoplastron.

shield boundaries and far less robust plastron; that *A. petrosus* Cope had a steeper, less flanged or shovel-shaped nuchal region, with the hornshield sulci nearer the marginal border, and the plastron lighter; that *Adocus (Pleurosternum) pectoralis* had a much less massive plastron and narrower bridge than *A. tardus*; and that finally *A. (Amphiemys) oxysternum* from the Tertiary of Georgia is a fairly distinct species from all of the foregoing Cretaceous Agomphids.

*Measurements of Agomphus tardus Type.*

(Yale Museum Specimen No. 774. Skeletal elements uncrushed.)

## THE CARAPACE.

Length on straight line .....	33· cm
Length over curvature .....	43·5 ±
Width (greatest, or over 4th neural) .....	23· ±
Distance over curvature (greatest) .....	38· ±
Projection beyond front end of plastron .....	1·5
Projection beyond anal end of plastron .....	7·

[Thickness of nuchal (anterior), 1·3<sup>cm</sup>; (posterior), 7<sup>mm</sup>; of the 2d neural 1·4<sup>cm</sup>; of the 5th neural 1·5<sup>cm</sup>. With the exception of the distal extremity of the second pleural, which reaches the great thickness of 2·2<sup>cm</sup>, the pleurals are of much the same development throughout, their thickness being quite nearly indicated by that of the marginals given in transverse section.]

## BONY PLATES OF CARAPACE.

	Length on marginal border of carapace.	Middle length from marginal border of carapace to pleurals.
Nuchal .....	5·2	5·3
1st marginal .....	4·	4·3
2d .....	4·2	4·6
3d .....	3·8	--
4th .....	3·8	--
5th .....	4·	--
6th .....	4·	--
7th .....	--	--
8th .....	--	--
9th .....	--	5·
10th .....	3·8	4·5
11th .....	4·2	4·
Marginalo-pygal .....	4·	3·

	Length (Antero-posterior).	Greatest width (lateral).
Nuchal .....	5·2	7·3
1st neural .....	--	--
2d " .....	4·	3·5
3d " .....	--	--
4th " .....	--	--
5th " .....	4·	3·6
6th " .....	--	--
7th " .....	--	--
8th " .....	(absent)	(absent)
9th " .....	--	--
Pygal .....	(3·)	--

(Lateral length 1st, 2d, and 7th pleurals 9·5<sup>cm</sup>, 12<sup>cm</sup>, and 8·7<sup>cm</sup> respectively.)

THE PLASTRON.

	Greatest length on medium line.	Greatest width.
Epiplastron .....	--	--
Entoplastron .....	4.3	4.5
Hyo-plastron ..	6.0	10.
Hypoplastron .....	6.2	9.5
Xiphiplastron .....	7. ±	3.3

(Greatest thickness of the hyoplastron measured on interior border 2.7<sup>cm</sup>, of the hypoplastron 3.1<sup>cm</sup>. Least width of hyoplastron measured across axillary border 5.6<sup>cm</sup>, of the hypoplastron across the femoral border 5<sup>cm</sup>,—whence least width of bridge, 10.6<sup>cm</sup>.)

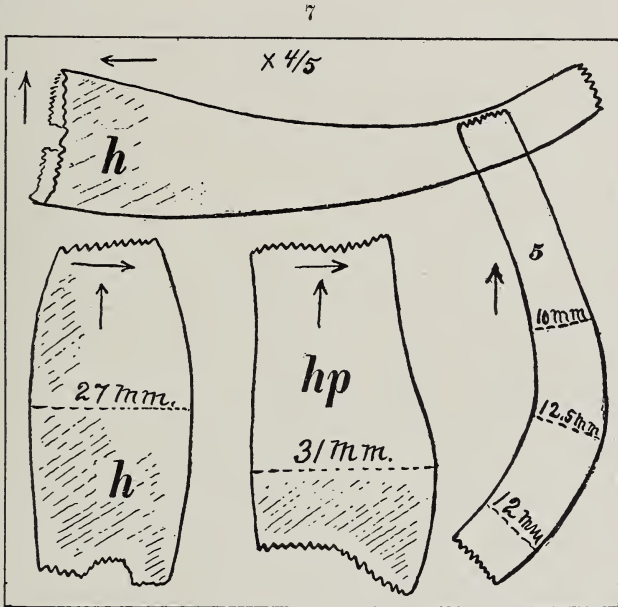

FIGURE 7.—*Agomphus tardus* (type).  $\times \frac{4}{5}$ . Outline of sutural faces (or transverse sections) of the hyoplastron, the hypoplastron, and the 5th marginal. *h, h*, posterior and internal sutural face of hypoplastron; *hp*, internal sutural face of hypoplastron, which placed tandem to *h* yields the median transverse section of the plastron, exclusive of the epi-, the ento- and xiphiplastron; *5*, anterior face, 5th marginal. The arrows orient to the vertical and median lines.

*Agomphus masculinus* Wieland (sp. nov.)—(Figure 8).

The beautifully fossilized plastron accompanied by various marginals, a nuchal and fragmentary pleurals of a smaller turtle than the preceding, received at the Yale Museum from the West Jersey Marl Co.'s pits, at Barnsboro, Gloucester

County, New Jersey, in April, 1872, and numbered 671 in the Marsh Collection, is here made the type of the new species *Agomphus masculinus*. This specimen undoubtedly pertains to

8

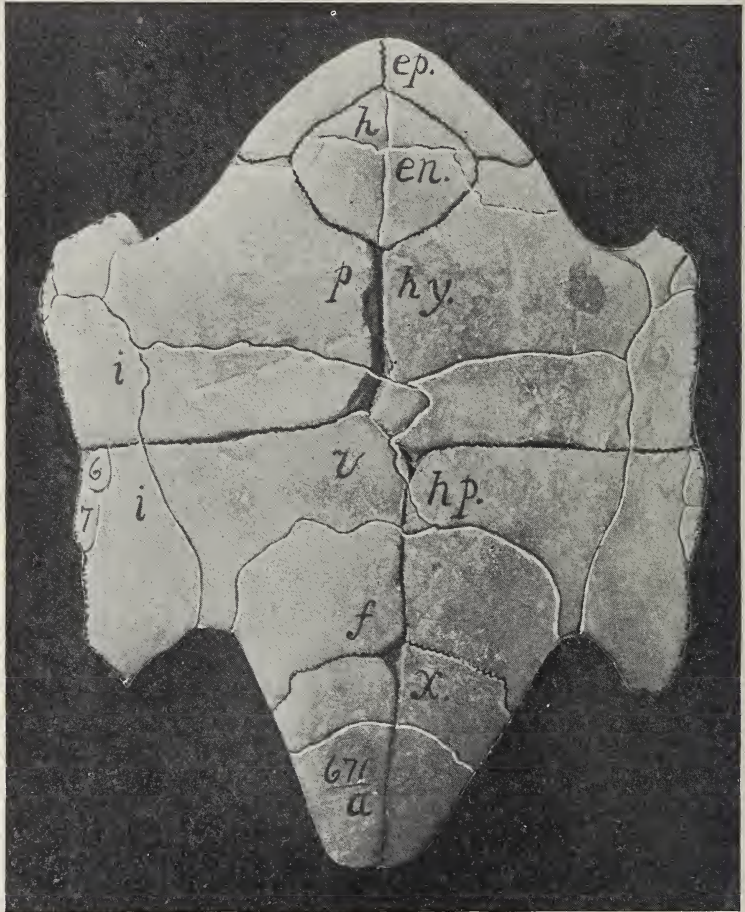

FIGURE 8.—*Agomphus masculinus* Wieland (sp. nov.). The plastron of the type specimen (No. 671, Marsh Collection), consisting in the entoplastron, hyoplastra, hypoplastra and right xiphiplastron complete (with the missing epiplastra and left xiphiplastron restored).  $\times \frac{3}{11}$ .

(1) Bone plates.—*ep.*, epiplastron; *en.*, entoplastron; *hy.*, hyoplastron; *hp.*, hypoplastron; *x.*, xiphiplastron.

(2) Hornshields.—*h.*, humeral (in part); *p.*, pectoral; *v.*, ventral; *f.*, femoral; *a.*, anal; *ii.*, inframarginal region (above which the axillary inframarginal appears completely outlined); 6, 7, inner borders of the 6th and 7th marginal shields.

an originally complete fossil shell, but the several parts secured, although as numerous as in the preceding fossil, scarcely have the fortunate situation making possible a similar restoration.

The elements are all matrix-free, uncrushed and disarticulated, with the sutural faces all clearly outlined (save a small outer border portion of the left side of the plastron). Also the narrow to line-like hornshield sulci are all distinct in every instance. Unfortunately, but a single example of the present species is known with certainty.

The plastral features of *A. masculinus* as shown in figure 8 are more nearly similar to those of *A. tardus* than to those of any other known Agomphid. Specific identity is however clearly indicated by the slightly less robust form with relatively larger hypoplastra and ventral hornshields, and an entoplastron of sub-rhombic instead of sub-isosceles outline.

It is further to be observed that the doubly sigmoid antero-posterior curvature of the plastron is greater than in any other known species of *Agomphus*. Although this feature does not clearly appear in the photographic figure 8, it is so strongly accentuated in the fossil itself as to suggest that it is an individual peculiarity denoting an old male turtle, or perhaps better tortoise, whence the specific name.

In addition a new specific character is exhibited by the complete nuchal, and the third, eighth and tenth marginals accompanying the present plastron. These show that the marginal hornshields anterior to the eleventh did not overlap the pleuro-marginal sutures, and that the eleventh and twelfth did so. As this peculiarity is not present in either *A. turgidus* or *A. tardus*, it in a sense unites *Agomphus* with *Adocus* since in *Adocus punctatus* at least, a similar hornshield overlap begins with the fifth marginal hornshield.

(a) *Measurements of the Plastron of Agomphus masculinus Type.*

Extreme length.....	17	cm
Extreme width.....	13	
Length of bridge suture.....	10	
Distance between the axillar and femoral borders.....	7.9	
Length of the hyo-hyoplastral suture.....	5.5	
Length of inner hyoplastral suture.....	4.	
Length of inner hypoplastral suture.....	3.5	
Length of inner xiphiplastral suture.....	4.5	
Lateral width of entoplastron.....	3.6	
Antero-posterior length entoplastron.....	3.4	
Greatest thickness entoplastron.....	1.5	
Greatest thickness hyoplastron.....	1.8	
Greatest thickness hypoplastron.....	1.8	
Greatest thickness xiphiplastron.....	1.6	

*Specimens 775 and 776.\*—(Figure 9).*

The characters of the plastron in the genus *Agomphus* are shown in still further specific detail by the complementary specimens 775 and 776 of the Marsh Collection, as represented in the retouched photographic figure 9. These two specimens, the parts of which are enumerated in the legend of figure 9, do not necessarily pertain to the same species. In fact specimen 776 indicates a turtle with a slightly heavier plastron and broader bridge than 775, although quite similar in all other comparable respects.

Specimen 776 probably belongs to *A. (Emys) turgidus*, although we note that it may perchance be separated from this form by the different outline of the humeral hornshields, and from *Adocus* (or *Agomphus*) *pectoralis* by the relatively larger plastral bridge. The bones, while unusually robust, do not reach the great thickness seen in both *A. tardus* and *A. masculinus*.

It is furthermore to be observed that specimen 775 is distinguished from both the species just named as well as from all other Adocidæ so far as known, by the series of accessory parallel growth lines of both the anterior and posterior sulci of the femoral hornshields. This peculiarity, as distinctly shown in figure 9, recalls the obverse condition of change from deep sulci in the nuchal region to narrow line-like sulci on all the rest of the carapace seen in *Adocus punctatus*. An imperfect accompanying hyoplastron however suggests proportions similar to those of *Adocus (Pleurosternum) pectoralis*, which we are fairly satisfied is an *Agomphus*. Were specimen 775 assigned to a new species, no one could say nay on the basis of the material now known, but to do so could only be defended, were no further examples likely to be yielded by the New Jersey Cretaceous.

While it is not therefore convenient to assign these specimens to any of the half dozen known types, and much less so to propose a new species for No. 775, it is held that whoever is fortunate enough to discover additional new specimens illustrating the doubtful points involved, will first be entitled to determine these specific values. For the present it is therefore only attempted so far as fairly practicable to make accessible the features of Agomphid structure. Nor do we consider that on last analysis there is any essential difference between this structural study and the more purely taxonomic point of view.

\* No. 775 is from the Cream Ridge Marl Co.'s pits, Hornerstown, Monmouth Co., New Jersey. It was received at the Yale Museum in April, 1871. No. 776 is doubtless from the same locality, but there is a discrepancy in the Museum record, so that it is not positively known where this fossil is from.



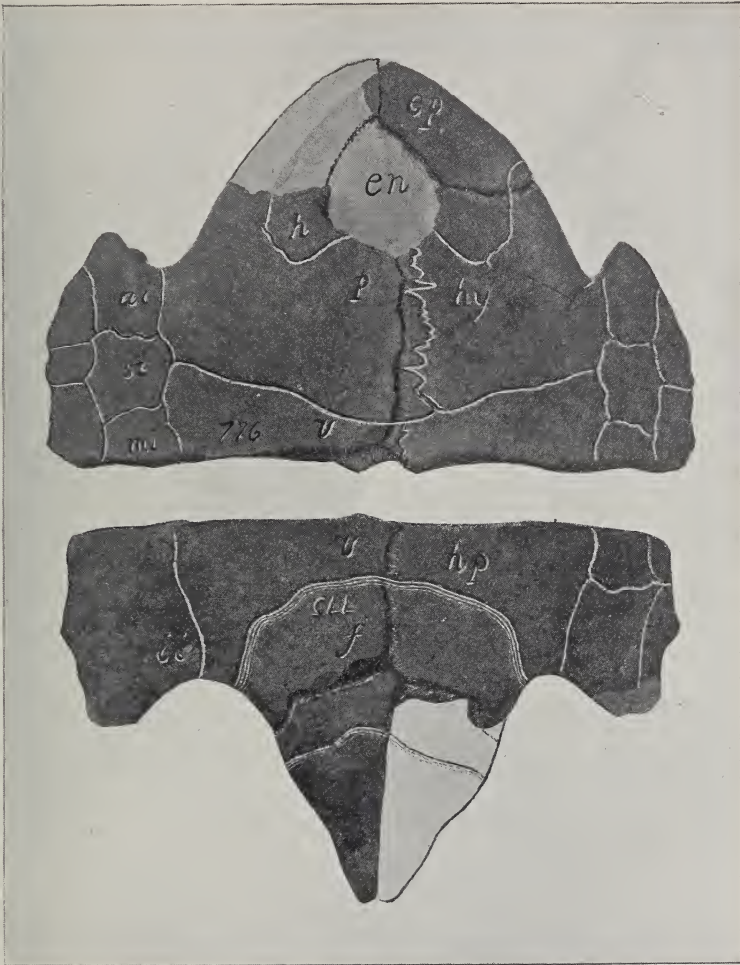

FIGURE 9.—*Agomphus*. Two complementary specimens illustrating plastral structure. No. 776, consisting in the hyoplastra and epiplastron, may be doubtfully referred to *A. turgidus*. No. 775, consisting in the hypoplastra and xiphiplastron, is of more uncertain specific reference. Both the specimens are shown exactly  $\frac{2}{3}$  natural size.

(1) Bone plates.—*ep*, epiplastron; *en*, entoplastron; *hy*, hyoplastron; *hp*, hypoplastron; (xiphiplastron not lettered).

(2) Hornshields.—*h*, humeral (in part); *p*, pectoral; *v*, ventral; *f*, femoral; *ai*, axillary—*si*, sub-axillary—*mi*, mesial—and *ii*, inguinal inframarginalia; (anal hornshield not lettered).

*Agomphus turgidus* (Cotype).

It is of interest to further note that the specimen (number 900) from the Cream Ridge Marl Co.'s pits Hornerstown, Monmouth Co., New Jersey, received at the Yale Museum in 1869, is clearly a second specimen of *A. turgidus* Cope, from the same locality as the type, and exhibiting various further structural features. Indeed here is still another instance in which more elements are present than in the above described *A. tardus*, although without the fortunate distribution permitting a restoration as in that specimen. These portions are: the entoplastron and both *hyoplastra* (that of the left side articulating with the nearly complete 3d marginal), the right 5th–11th marginals (the 6th and 7th having the superior and inferior borders broken away), the pygal marginal and the lower halves of the left 4th, 6th and 7th marginalia; also the second, a 6th or 7th neural, and the third and fourth neuralia complete with the proximal ends of the left 3d–5th and the right 4th pleuralia attached.

The specific characters of *A. turgidus* have already been commented on indirectly, so that further description of the present specimen which has been of much use in determining the preceding new species, is scarcely required. The original fossil shell was doubtless complete, and had but a few more fortunately situated elements been recovered a restoration could be made.

*A. turgidus* did not have as massive a shell as *A. tardus*, but presents all the characteristic generic features distinguishing *Agomphus* from *Adocus*; in particular the heavy shell, the sharp to acuminate rather than rounded xiphiplastral end of the plastron, and the marginalo-costal suture resting on the marginals, instead of rising up onto the pleuralia beyond the third marginal hornshield.

*Synopsis of the Characters of Agomphus.*

The description of the foregoing new species of *Agomphus*, *A. tardus* and *A. masculinus*, and of the plastra of more or less doubtful specific identity numbered 775 and 776 in the Marsh collections, together with a topotype of *A. turgidus*, finally acquaints us with the shell structure of this interesting Upper Cretaceous genus as follows:

*Carapace*.—Medium sized to small, of elliptical outline, considerable depth, and with thicker walls in some species than in any other known Testudinates. Composed of 49 bony plates (one more or less, depending on the presence or absence of 7th and 8th neurals), and without fontanelles. Hornshield sulci small and line-like to indistinct.

(a) *Bony plates*.—Marginals, 11 pairs, very heavy; nuchal, large, of sub-pentagonal outline, without a nether process, but with costiform processes sometimes perforating the entire 1st marginals (*A. tardus*); neural series with but seven or eight members—the 9th or post neural being present with suppression of the 7th, or both 7th and 8th; pygal single as in *Adocus*; pleuralia very heavy with medium to slight development of the rib capitulæ.

(b) *Hornshields*.—A medium-sized nuchal and twelve pairs of marginals with the inner or marginalo-costal suture not rising onto the pleurals, as in *Adocus*, but traversing the marginal plates throughout (except in the single species *A. masculinus*, where the penult and final or pygal shields respectively overlap the 8th pleural and pygal plate.

*Plastron*.—Of medium size, without fontanelles and very heavy with the strong bridge suture extending from the posterior end of the 3d to the anterior end of the 8th marginal. Entoplastron large, of sub-isosceles triangular to rhombic outline. Epiplastral border rounded; anal region acuminate in every known species—not rounded as in *Adocus*.

*Agomphus* is held to be distinct from the earlier proposed genus *Adocus* mainly because of the position of the marginalo-costal suture on the marginals, the very characteristic form of the plastron, and the enormous thickness of shell. Although some of the imperfectly known species may prove to intervene and bridge these gaps—not large when taken singly,—it appears at present that they uniformly separate an Agomphid series of closely related, mostly small turtles ranging from the Upper Cretaceous into the Eocene. Therefore, as both *Adocus* and *Agomphus* are numerous in species, it would seem to be much the better policy to retain the latter genus so long as not definitely proven to merge into the former. The species respectively assigned to these two closely related genera of the Adocidæ therefore are:

1. *Adocus (Emys) beatus* (Leidy) Cope.
2. “ *agilis* Cope.
3. “ *pravus* (Leidy) Cope.
4. “ *syntheticus* Cope.
5. “ *punctatus* Marsh.
6. *Agomphus (Emys) turgidus* (Leidy) Cope.
7. “ “ *firmus* (Leidy) Cope.
8. “ (*Amphimys*) *oxysternum* (Cope) Hay.
9. “ *petrosus* Cope.
10. “ (*Adocus*) *pectoralis* (Cope) Wieland.
11. “ *tardus* Wieland.
12. “ *masculinus* Wieland.

From this numerous assemblage of species we naturally come to ask how turtles with such thick shells as the Agomphids, the more naturally ascribed to land forms, came to be so intimately associated with *Osteopygis*, *Lytoloma*, and the various other semi-marine to marine turtles and other forms which teem in all the *Agomphus* localities in the Upper Cretaceous marl beds of New Jersey. Being mostly small turtles the heavy specialized shells would mainly serve as a protection from the other larger and more powerful reptiles, which swarmed along and into the bays and estuaries of the New Jersey Cretaceous shore line, so that a salt water littoral habitat is not precluded. But while no specimens of the Marsh or other collections illustrating limb or cranial structure have yet been referred to *Agomphus*, it would seem that at least some of the species of the genus dwelt back from the shore line along the streams, on the more or less sandy river, ox-bow, or delta banks, and doubtless in the vast numbers paralleling the Orinocan *Podocnemis*, the easy prey of the jaguar, and once far more abundant on lower river courses than now. From such locations many shells might be carried forward to the shore front in flood time or in the course of estuarial change. Also, if congregating in any considerable numbers on the more nearly forest-free river banks, or on dune slopes, at egg-laying time, many individuals might then be either preyed on by other animals, or swept shoreward. It is a fact of some slight bearing on such a conjecture that while the Adocidæ are much more numerous than the other Testudinales of the marl beds, nearly all the limb bones recovered pertain to the semi-marine to marine Osteopygid and Lytoloman series. Moreover the abundance of the fossils of the marl beds is probably not generally understood, since almost no specimens have been secured in the past twenty-five years. Only a very few per cent of the specimens uncovered in the marl pits, when excavation was actively carried on thirty years ago, ever made their way into the museums; and these were all from restricted areas, although these fossils were for the greater part abundant everywhere in the several fossiliferous horizons of the entire New Jersey marl belt.

Yale Museum, New Haven, Conn.

ART. XLV.—*The Cambro-Ordovician Limestones of the Middle Portion of the Valley of Virginia*; by H. D. CAMPBELL.

NEITHER the Knox dolomite nor the Shenandoah limestone, if used as the name of a geologic formation, should be made to include all of the Cambrian and Ordovician limestones of the Valley of Virginia from Tennessee to Maryland.

M. R. Campbell\* makes the Shenandoah limestone of southwest Virginia comprise not only the Knox dolomite but at least 1500 feet of Cambrian strata beneath it. He also describes two formations of limestone above the Shenandoah and recognizes 500 feet of subjacent variegated shale and impure limestone.

At the border between Tennessee and Virginia† he makes the Shenandoah limestone include not only the Knox dolomite but five other formations, remarking that the six merge into one formation which prevails along the eastern side of the Appalachian valley at least as far as Pennsylvania.

It is not the purpose of this article to discuss the correlation of the Knox dolomite and the Shenandoah limestone, which can be satisfactorily accomplished only after several additional sections across the valley of Virginia have been described in detail and the fossils from fixed horizons have been compared.

This introduction is offered as an explanation for using the following entirely new names for the formations recognizable in the limestones of the portion of the Appalachian valley near Lexington and the Natural Bridge, Virginia.

*Section of the Valley Limestones near Lexington, Virginia.*

Period.	Name of formation.	Thickness in feet.
Ordovician	Liberty Hall limestone	1000 ±
	Murat limestone	100-150
	Natural Bridge limestone	3500 +
Cambrian	Buena Vista shale	600-900
	Sherwood limestone	1600-1800

*Sherwood limestone.*—In the bluff of James River at Sherwood, Va. and for more than twelve miles to the southwest, the lower part of this formation consists of several hundred feet of white crystalline dolomite. This dolomite is overlaid by heavy beds of light blue and gray magnesian limestone with occasional beds of shale and shaly limestone. It was just beneath or at the very base of the Sherwood limestone that

\* U. S. Geol. Surv., Geol. Atlas of U. S., Folio No. 26, 1896.

† Ibid., Folio No. 59.

C. D. Walcott\* found Lower Cambrian fossils. The formation is superjacent to the quartzites and shales of the Balcony Falls section.

*Buena Vista shale.*—Bright variegated shale is conspicuous in the bluffs of James River between Sherwood and Buchanan, and along the road between Sherwood and Natural Bridge. Red bands predominate, but green, yellow, and brown colors are common. Mottled blue limestone beds alternate with the shale in the lower part, and it passes by a succession of shale and limestone beds into the superjacent limestone. In this formation C. D. Walcott† found a *Ptychoparia* closely related to species from the Middle Cambrian beds of Tennessee. The formation is from 600 to 900 feet thick. It receives its name from Buena Vista, Va., where it is well developed.

*Natural Bridge limestone.*—The formation consists principally of heavy-bedded gray and light blue magnesian limestones with thin siliceous laminae as a conspicuous feature, especially upon weathered surfaces. Beds of white and pinkish dolomite occur now and then. Calcareous sandstone strata from a few inches to eight feet thick are occasionally prominent. Black chert occurs in nodules more or less throughout the formation, but heavy beds of chert are usually very conspicuous near the top. Specimens of *Lingulepis* and *Obolus* were discovered by C. D. Walcott in this formation two miles below Buffalo Mills on Buffalo Creek in June 1898, thus establishing by fossils the age of part of this limestone as Cambrian. Fossils from 300 or 400 feet below the top of this formation make the age of its upper beds Beekmantown (Calciferous).‡

On account of the difficulty of determining the geologic structure in this section, the total thickness of the formation has not been accurately determined, but measurements which were made in a continuous series where there was no indication of folding or faulting indicate a thickness of over 3500 feet. The Natural Bridge and its canyon display part of this limestone, and hence the name.

*Murat limestone.*—Superjacent to the heavy chert beds of the Natural Bridge limestone occurs a massive gray crystalline limestone containing bryozoa and other fossils in abundance. About 125 feet of it are well exposed along Buffalo Creek at Murat, Va., whence the formation takes its name. Its lower portion often contains chert nodules. The deep red clay soil resulting from the Murat limestone is conspicuous in contrast with the gray cherty soil from the top of the Natural Bridge formation.

\* This Journal, July 1892, p. 53.

† Ibid., p. 52.

‡ R. S. Bassler, Bull. U. S. Geol. Surv. No. 243, 1905, p. 315.

*Liberty Hall limestone.*—In describing a section through this region in 1879, J. L. Campbell\* used the name Lexington limestone for this formation, but inasmuch as the same name is given to certain Silurian rocks in Kentucky,† it has been rechristened Liberty Hall limestone from the name of an old historic ruin which is constructed on and of this rock, and which has been standing for more than a century and is as well known in this region as Lexington itself.

The Liberty Hall limestone is usually a succession of rather evenly banded beds of fine-grained, dark blue limestone and darker, more argillaceous limestone which weathers shaly. As we ascend into the formation calcareous shale predominates and limestone beds are less frequent. In this region the formation has been much fractured and folded, and sometimes appears massive with innumerable veins of infiltration of calcite filling the crevices. Again it appears shaly after long exposure to weather. Brachiopods and trilobites of Mohawkian age are especially abundant in the lower beds. From the top of the Murat through the limestone and calcareous shale, so long as it carries conspicuous limestone beds, the Liberty Hall limestone is about 1000 feet thick. Then follows about 600 feet of shale and slabby sandstone to the bottom of the first bed of quartzite above the Valley limestones. The thick beds of shale above the limestones, both northeast and southwest of the section here considered, give rise to another problem of correlation.

Washington and Lee University,  
Lexington, Virginia, October 31, 1905.

\* This Journal, xviii, 1879, p. 29.

† U. S. Geol. Surv. Geol. Atlas of U. S., Folio No. 46, 1898.

ART. XLVI.—*Relations of Ions and Nuclei in Dust-free Air;*  
by CARL BARUS.

1. In the following table I shall give typical results of the nucleation computed from the coronas observed in a glass fog chamber, in the presence or absence of external radiation, when the saturated dust-free air contained is suddenly cooled by partial exhaustion of successively increasing magnitude. The amount of exhaustion (with which the supersaturation goes in parallel) may be conveniently specified in terms of the drop in pressure,  $\delta p$ , between the outside and the inside of the given moderately efficient fog-chamber. Since the barometer was nearly normal, the corresponding volume increase, etc., may be readily derived.

TABLE I.—Typical results of the ionized and colloidal nucleation of dust-free air, energized (or not) by weak and strong radiation. Fog chamber about 50<sup>cm</sup> long, 15<sup>cm</sup> in diameter; walls of glass 3<sup>cm</sup> thick, ends 1<sup>cm</sup> thick—Piping of one inch gas pipe. Barometer about normal. *D*, distance between walls of fog chamber and anticathode or sealed aluminum tube with weak radium.

X-rays		X-rays		Radium		X-rays		X-rays	
<i>D</i> =∞	from end	<i>D</i> =600 <sup>cm</sup>	from end	<i>D</i> =0 <sup>cm</sup>	from side	<i>D</i> =100 <sup>cm</sup>	from end	<i>D</i> =50 <sup>cm</sup>	from side
$\delta p$	$n \times 10^{-3}$ .	$\delta p$	$n \times 10^{-3}$ .	$\delta p$	$n \times 10^{-3}$ .	$\delta p$	$n \times 10^{-3}$ .	$\delta p$	$n \times 10^{-3}$ .
21	0	19	? 0	19	.2	18	0	18	0
23	.5	20	2	20	2	19	1	19	2
25	1.7	21	8	21	10	20	20	20	*10
27	.5	22	20	22	28	21	37	21	*28
28	18	23	28	23	38	22	50	22	57
29	45	24	33	24	45	24	75	24	93
30	59	26	36	25	50	26	95	25	110
32	73	28	37	26	52	28	110	27	133
34	87	30	39	28	53	30	124	29	145
36	100	34	41	30	55	35	135	32	155
--	--	--	--	35	56	--	--	35	160

In computing the (fleeting) nucleation one is left in doubt whether the nuclei (ions) are restored to the air more quickly than they can be removed by exhaustion; or whether the reverse is true. I have assumed the former to be the case and call this nucleation (number per cubic cm.) *n*. If the nuclei are removed more quickly than they are reproduced, it will be necessary to multiply *n* by the corresponding volume increase, and I shall call this value *N*. In the present experiments† *N*

\* Probably reduced by the presence of persistent nuclei in small number.

† At high values of  $\delta p$  both *n* and *N* become untrustworthy as absolute values; but they suffice very well to indicate the relations.



is usually much larger than  $n$ . In the cases of persistent nucleation due to the X-rays or other causes,  $N$  is obviously to be taken; but here from the low values of  $\delta p$  which suffice for condensation, the difference is not so important.

2. To vary the intensity of radiation, the anti-cathode of the X-ray tube or the radium tube (of thin aluminum, hermetically sealed, holding 10 mg. of weak radium —10,000  $\times$ — within), is placed at a distance,  $D$ , from the outside of the fog-chamber. This was a horizontal cylinder of glass, 50<sup>cm</sup> long and 15<sup>cm</sup> in diameter, with the end toward the bulb 1<sup>cm</sup> thick and the side wall 3<sup>cm</sup> thick. When  $D$  is measured from the end, persistent nucleation is not usually producible\* because of the thickness of the glass to be penetrated. When  $D$  is measured from the sides, however, persistent nucleation just begins at  $D = 50^{\text{cm}}$  and increases at a rapidly accelerated rate for smaller distances. Hence the ionization corresponding to  $D = 50^{\text{cm}}$  is a transitional value at which fleeting nuclei or ions merge into persistent nuclei.

3. If the data are constructed graphically, it appears that all the curves are eventually intersected by the curve for dust-free non-energized air. In the latter we may recognize a region of ions (say from  $\delta p = 21^{\text{cm}}$  to  $27^{\text{cm}}$ ) and a region of colloidal nuclei for larger values of  $\delta p$ ; but the whole phenomenon is continuous. The effect of radiation as seen in the other curves is therefore to decrease the efficient nucleation of

TABLE II.—Persistent (large) nuclei ( $N$ , number per  $\text{cm}^3$ ) produced by intense X-radiation, in dust-free air.  $\delta p = 18^{\text{cm}}$ , being decidedly below the fog-limit.  $D$  measured from *side* of glass fog chamber (wall 3<sup>cm</sup> thick) to anticathode. Aluminum screen inserted.

$D =$	12	20	30	40	50 <sup>cm</sup>
$N \times 10^{-3} =$	140	56	10	1	1

dust-free air more noticeably when the radiation is weaker and the supersaturation higher. These results may be tried directly for instance, with the radium tube at different distances,  $D$ ; for a fixed pressure difference,  $\delta p$ . Thus at  $\delta p = 41^{\text{cm}}$  the nucleation passes through a minimum at  $D = 25^{\text{cm}}$  when  $D$  increases from 0 to  $50^{\text{cm}}$ . The effect of radiation is then virtually an aggregation of the colloidal nuclei of dust-free air. If the effect of ionization were merely to mask the presence of the smaller colloidal nuclei, the same effect should occur at intense ionization. Here, however, nuclei larger as well as indefinitely smaller than the mean ionic gradation are produced like the latter in continually greater numbers as the radiation increases. The case is rather one in which relatively

\*I have since succeeded in producing persistent nucleation through thin tin plate.



supersaturations and the asymptotes (or maxima) are in every case reached and much higher in value. The range of supersaturation within which the condensations begin and are nearly completed is reduced so that the curves are usually steeper. In case of the new curve for non-energized air (and to the same extent in the others) the relative absence of nuclei in the region of ions is a distinguishing peculiarity. Investigated by the coronal methods, the curves rise, as it were, abruptly from the abscissa, and there is a rise of fog limit.

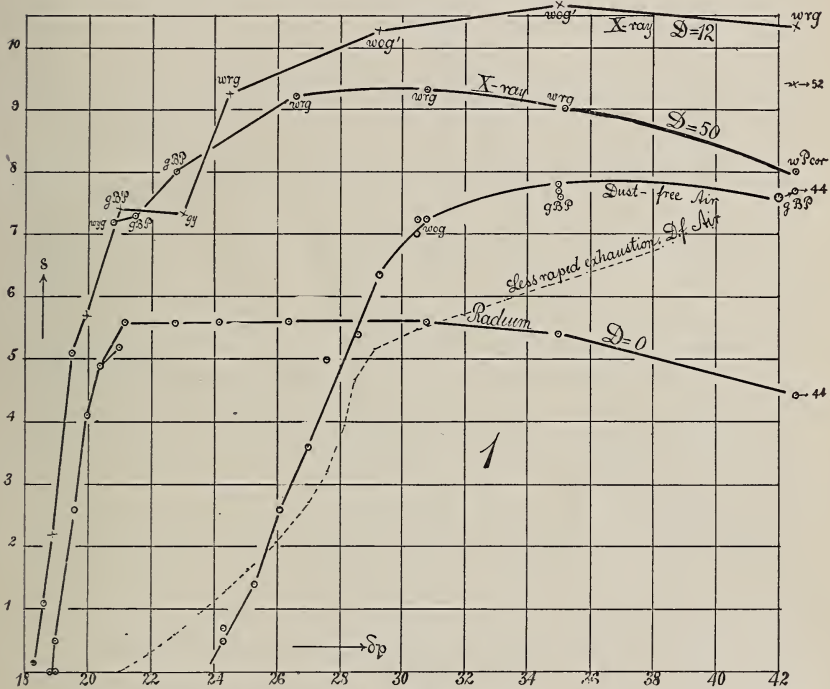

FIG. 1.—Charts for Table III, showing the coronal apertures (angular diameter being  $s/30$ ) in cases of different supersaturation (pressure drop on exhaustion  $\delta p$ ) in cases of non-energized dust-free air, and of dust-free air energized by radium and the X-rays from different distances,  $D$ . The dotted curve corresponds to less rapid exhaustion (Table I). Its intersection with the corresponding curve drawn in full should be noticed. It indicates the presence of a group of larger nuclei present in the former case and absent in the latter.

5. In connection with the present data, different suggestions made in the earlier paper and diverging from the more usual explanations, may be recalled: The effect of radiation if not too strong, has been shown to be virtually an aggregation of the colloidal nuclei of dust-free air. It seems probable

that the ions or fleeting nuclei are such loose aggregates built up out of colloidal nuclei, because evidence of the presence of colloidal nuclei absent at the low ionizations (exposure to weak radiation) is manifest at the high ionizations (exposure to intense radiation). If the radiation is very strong all sizes are represented, showing that the aggregates are virtually built up out of continually smaller colloidal nuclei probably closely approaching the molecular sizes, while at the same

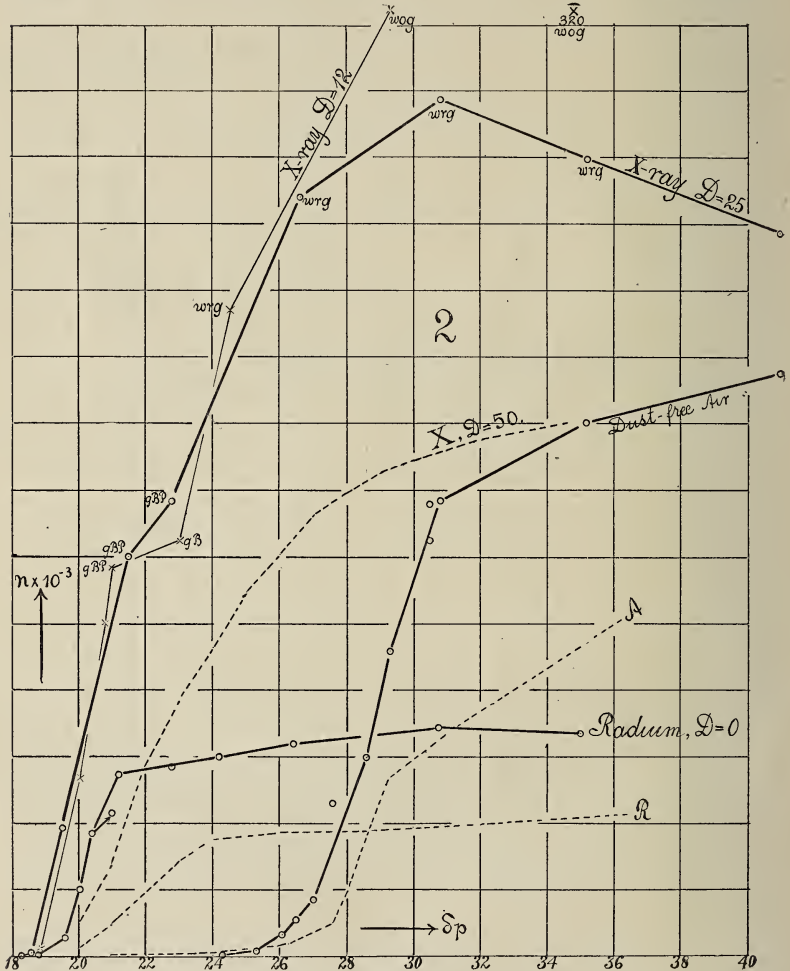

FIG. 2.—Charts for Table III showing the nucleation  $n$  in terms of the supersaturation (pressure drop  $\delta p$ ), for dust-free non-energized air, and for dust-free air energized by radium (10,000  $\times$ , 10 mg.) from different distances  $D$ . The dotted curves show the corresponding cases (Dust-free air,  $A$ ; Radium,  $R$ ; X-rays,  $X$ ) for less rapid exhaustion (Table I). The vertical spaces represent 20,000 nuclei each.

time the existing nuclei are further aggregated into larger systems.

Within the fog-chamber it is probable that the radiations whether undulatory or corpuscular, is at any point the same in all directions, for the nuclei in any given case are largely produced by secondary radiation.

Hence it follows, qualitatively at least, that the inside of the fog-chamber is an ideal Lesage medium. One may argue, therefore, that a corresponding tendency for the preëxisting colloidal nuclei of dust-free air to aggregate into ions or larger bodies, should be manifest. Again the ions, conditioned by the presence of radiation, must fall apart when the radiation is withdrawn, and this is the case. One may infer also that the nucleating effect produced by negative corpuscles would be different from that corresponding to the positive residuals.

Let the kinetic ionization pressure be supposed to increase as the square of the velocity of the corpuscles and as their density of distribution; then if the ionization becomes very intense it is possible that the pressure becomes strong enough to produce permanent union of the loose aggregates, or that the fleeting nuclei eventually become persistent, as is the case.

If the ionized field is intensely produced by corpuscles issuing from within the body itself, as for instance, in combustion, or ignition, etc., one may expect that large nuclei as well as fleeting nuclei should simultaneously appear; or that nucleation, passing through a transitional stage from fleeting to persistent as the electrification is more intense, should be the invariable concomitant of ionization. It is probable that the expulsion of corpuscles takes place whenever persistent nuclei are produced. Thus in the case of the X-rays, the generation of persistent nuclei occurs at an accelerated rate with time for a fixed radiation. If the radiation is cut off, nuclei are spontaneously generated (secondary generation) for some time after.

Arguments to the same effect would follow for light pressure for wave lengths small enough to be easily scattered. Thus persistent and fleeting nuclei as a simple continuous phenomenon are produced by the X-rays (Table II), in the manner identical with the case of ultra-violet light. Similarly nuclei grow large in size as the ignition, the potential differences, etc., are larger.

Finally, although the colloidal nucleation of dust-free air may be conceived to be aggregated both by undulatory and by corpuscular pressure, it is only in the latter case that the nuclei can be influenced by an electric field because the corpuscles are themselves actuated. This distinction in fact exists between nuclei otherwise quite identical fleeting or persistent, but produced in one case by ultra-violet light and in the other by the X-rays or the action of radium.

ART. XLVII.—*Additional Notes upon the Estimation of Cadmium by Means of the Rotating Cathode, and Summary;*  
by CHARLES P. FLORA.

[Contributions from the Kent Chemical Laboratory of Yale Univ.—exli.]

I. *The Behavior of Cadmium Nitrate.*

SINCE cadmium is not readily precipitated by the electric current from solutions containing even small amounts of free nitrate acid, it was to be expected that cadmium nitrate would prove to be little fitted for estimation by electrolysis, since the action of the current would produce nitric acid. This, in general, was the result of my experiments upon the estimation of cadmium in the form of the nitrate upon the rotating cathode. The deposits obtained from solutions containing sulphuric acid, the phosphates, pyrophosphates, urea or formaldehyde, were satisfactory, but the time necessary for complete deposition is so prolonged that these solutions are comparatively valueless for the estimation of cadmium taken as the nitrate, since it would be easier and more trustworthy to transform the salt to the sulphate by evaporation with sulphuric acid before electrolyzing. With solutions containing acetic acid the metal was not precipitated, except in a narrow ring at the surface of the liquid. The behavior of solutions containing formic acid, tartaric acid, acetaldehyde and formaldehyde was similar, but less pronounced. The only solution from which I was able to obtain satisfactory results in the estimation of cadmium nitrate was a solution containing potassium cyanide. This solution was prepared by adding to the solution of cadmium nitrate, which had been standardized by the precipitation and ignition of the carbonate, the desired amount of sodium hydroxide, and then redissolving the precipitated hydroxide in an excess of potassium cyanide. The time needed for complete deposition is somewhat longer than that required where the chloride and sulphate of cadmium were taken, but the deposit was bright and very satisfactory. Care must be used to avoid the use of too large an amount of potassium cyanide. The following table shows the results obtained:

No.	Cd. gram.	KCN. gram.	NaOH. gram.	Cur't = amp.	N.D100. amp.	E.M.F. vts.	Time. min.	Tot. vol. cm <sup>3</sup> .	Cd. fd. gram.	Error. gram.
1.	0.0920	1.5	0.5	4.0	12.0	7.8	45	60	0.0933	+0.0013
2.	0.0920	1.0	0.5	3.0	9.0	7.6	35	60	0.0924	+0.0004
3.	0.1073	0.7	0.5	2.5	7.5	7.7	50	60	0.1072	-0.0001

II. *The Behavior of Solutions containing Free Nitric Acid.*

If free nitric acid be added to a solution containing a salt of cadmium, the precipitation of the cadmium by the electric cur-

rent will be retarded, and even prevented altogether if the nitric acid be present in sufficient amount. Upon this behavior have been based methods for the separation of copper, bismuth and mercury from cadmium.\* Tests were made by me to determine the amount of free nitric acid necessary to prevent deposition of the cadmium, and it was found that 2<sup>cm<sup>3</sup></sup> of nitric acid of 1:4 dilution in 50<sup>cm<sup>3</sup></sup> of solution (approximately 1 per cent of free acid) will absolutely prevent the precipitation of the cadmium upon the cathode (current, 3 amperes; E.M.F., 7.5 volts). If less nitric acid was used, traces of cadmium were deposited upon the cathode.

*Summary of Results obtained in the Estimation of Cadmium by means of the Rotating Cathode.*

The results of the work described in this and the previous papers upon the estimation of cadmium by means of the rotating cathode may be briefly summarized as follows: Under the conditions used, cadmium taken in the form of the sulphate may be very accurately and satisfactorily estimated by deposition from solutions containing sulphuric acid, sodium acetate and acetic acid, or potassium cyanide; but little less satisfactorily from solutions containing urea, formaldehyde or acetaldehyde; and also with proper precautions, from solutions containing pyrophosphates, phosphates, tartaric acid or formic acid. From solutions containing oxalates or oxalic acid, ammonium tartrate, or potassium formate, however, I was unable to obtain satisfactory deposits. When taken as the chloride, cadmium does not permit such a wide range of conditions. Nevertheless, from solutions of the chloride containing sulphuric acid or potassium cyanide, or the pyrophosphates, the metal is deposited in a form comparable with that obtained when cadmium sulphate is taken. Solutions of the chloride of cadmium to which is added hydrogen disodic phosphate gave less desirable results; while solutions containing urea, formaldehyde or acetaldehyde gave deposits free from sponginess only after careful regulation of the conditions. In addition to the solutions containing the oxalates, oxalic acid, the formates and the tartrates, negative results were given in the case of the chloride by solutions containing the acetates, formic acid, and tartaric acid. The nitrate of cadmium is ill-fitted for electrolytic estimation, the cyanide solution being the only one from which satisfactory results were obtained. From solutions containing one per cent or more of free nitric acid, the cadmium is not deposited by the current.

\* Edgar F. Smith, *Am. Ch. J.* ii, 42 (1880); Smith and Mayer, *J. Ch. Soc.*, lxiv, ii, 496 (1893); Kammerer, *J.*, *Am. Ch. Soc.*, xxv, 94 (1903); Rüdorff, *Z. angew. Ch.* (1894), 388.

ART. XLVIII.—*The Estimation of Cadmium as the Oxide* ;  
by CHARLES P. FLORA.

[Contributions from the Kent Chemical Laboratory of Yale Univ.—cxlii.]

CADMIUM may be simply and accurately estimated by converting the carbonate to the oxide by ignition. The oxide of cadmium may be subjected to very intense heat without loss from volatilization; but in the presence of any carbonaceous matter it is very easily reduced to the metal, which is quite volatile at high temperatures. Consequently, this method has always been subject to more or less change of error where paper filters have been used. The usual course has been to wash thoroughly and then dry the precipitated carbonate, which is then removed as completely as possible from the filter: the latter then being burned separately. Even here there has always been a very appreciable loss, to avoid which various more or less complicated modes of treatment have been offered. As a type of these, we may take that of Max Muspratt,\* who, after noting that high results were given by the ignition of the nitrate formed by dissolving the precipitated carbonate in nitric acid on account of included sulphate, proceeded as follows: The precipitated carbonate was washed and dried, and as completely as possible scraped free from the filter paper, and then converted to the oxide by gentle ignition. This carbonate was entirely free from sulphate. The filter paper was treated with nitric acid and the resulting solution and rinsings brought into a large porcelain crucible and evaporated to dryness. The dry nitrate was gently heated and the weight of the oxide obtained added to that of the mass of the precipitate. Even after this tedious procedure, Muspratt is obliged to suggest that the results will be more satisfactory if the oxide obtained by the ignition of the paper and the residues upon it be calculated as  $Cd_2O$  rather than  $CdO$ . Evidently the method would give satisfactory results if this reducing action of the filter could be avoided, and in former papers from this laboratory,† it has been shown that this may be accomplished by the use of asbestos filters in a Gooch crucible. There is then no danger of loss from reduction, and the carbonate method is simplified and placed among the good analytical methods. Recently, however, Miller and Page‡ have found that “the carbonate method is the most troublesome and the least satisfactory;” but these investigators did not use the asbestos filter.

\* J. Soc. Ch. Ind.; xiii, 211 (1894).

† Browning, this Journal (3), xlvi, 280 (1893); Browning and Jones, *ibid.* (4), ii, 269 (1896).

‡ Ch. News, lxxxiv, 312 (1901).



The work of the writer upon the carbonate method fully substantiates the previous work from this laboratory. For the determinations given, a solution of cadmium sulphate was used, whose standard was accurately given by the average of a large number of closely agreeing electrolytic determinations. Portions of this solution were accurately measured from a burette and diluted to 300<sup>cm</sup><sup>3</sup> with hot water. A 10 per cent solution of potassium carbonate was then added, drop by drop, with constant stirring until no further precipitation took place. The whole was then boiled for about fifteen minutes, when the precipitate became granular and quickly settled. It was then filtered upon an asbestos mat in a Gooch crucible, which had previously been ignited and weighed, and was then carefully washed with hot water. In several cases, washing by decantation was used. The precipitate was then dried and ignited over a Bunsen burner, first gently, then at full red heat until a constant weight was obtained, care being taken to avoid the reducing action of any unburned gas from the burner.

The following results were obtained :

No. of exp.	CdO taken. grm.	CdO found. grm.	Error. grm.
1.	0.1277	0.1275	-0.0002
2.	0.1277	0.1280	+0.0003
3.	0.1277	0.1272	-0.0005
4.	0.1399	0.1391	-0.0008
5.	0.1399	0.1399	±0.0000
6.	0.1703	0.1700	-0.0003
7.	0.1703	0.1700	-0.0003
8.	0.2129	0.2128	-0.0001
9.	0.2129	0.2128	-0.0001
10.	0.2554	0.2554	±0.0000

The method is simple in execution, and the above results prove its accuracy.

Some of the older manuals also give as a method for the estimation of cadmium that of igniting to the oxide the precipitated hydroxide obtained by adding a solution of sodium or potassium hydroxide to the solution containing the salt of cadmium. Follenius has published\* some results obtained with the use of an asbestos filter, and it was decided to try this method in comparison with the carbonate method. As in the experiments with the carbonate, portions of the solution of cadmium sulphate were carefully measured off from a burette, diluted to about 300<sup>cm</sup><sup>3</sup>, and heated to boiling. A 10 per cent solution of potassium hydroxide was then added drop by drop and the whole boiled for about fifteen minutes. Upon cooling, the precipitate quickly settled in a semi-granular state,

\* Z. anal. Ch., xiii, 284 (1874).

and was best filtered and washed by decantation. The results were lower than when the cadmium was precipitated as the carbonate, as is shown by the following table :

No. of exp.	CdO taken. grm.	CdO found. grm.	Error. grm.
1.	0.1277	0.1277	$\pm 0.0000$
2.	0.1277	0.1270	$-0.0007$
3.	0.1277	0.1260	$-0.0017$
4.	0.1277	0.1286	$+0.0009$
5.	0.1362	0.1350	$-0.0012$
6.	0.1399	0.1389	$-0.0010$
7.	0.1703	0.1697	$-0.0006$
8.	0.1703	0.1693	$-0.0010$
9.	0.1703	0.1699	$-0.0004$
10.	0.1788	0.1802	$+0.0014$
11.	0.2129	0.2139	$+0.0010$
12.	0.2129	0.2128	$-0.0001$

While the figures show that fair results may be obtained by the hydroxide method, it can be compared with the carbonate method neither for accuracy nor convenience: the precipitate does not attain the same granular form as that of the carbonate; it is hard to filter, difficult to wash, and can be removed completely from the beaker in which precipitation takes place only with the utmost difficulty.

---

ART. XLIX.—*The Mounted Skeleton of Triceratops prorsus in the U. S. National Museum*; by C. SCHUCHERT. (With Plate XV.)

NOTE.—At various times articles on Triceratops by the late Professor Marsh have been printed in this Journal, and as the U. S. National Museum is the first institution to possess a mounted skeleton of this, the largest-headed Dinosaur, it is deemed advisable to complete the records by reproducing here the illustration recently published in the Proceedings of that Museum.\* Mr. G. W. Gilmore did the mounting, and from his article the following extracts are taken :

Among the vertebrate fossils included in that part of the Marsh collection, now preserved in the United States National Museum, are the remains of several individuals pertaining to the large Cretaceous dinosaur, Triceratops. All of this material, which comes from the Laramie division of the Cretaceous, was collected by or under the supervision of the late Mr. J. B. Hatcher in the northeastern part of Converse County, Wyoming, a locality made historic by the researches

\* Article 1426, vol. xxix, 1905, pp. 433-435, 2 plates.

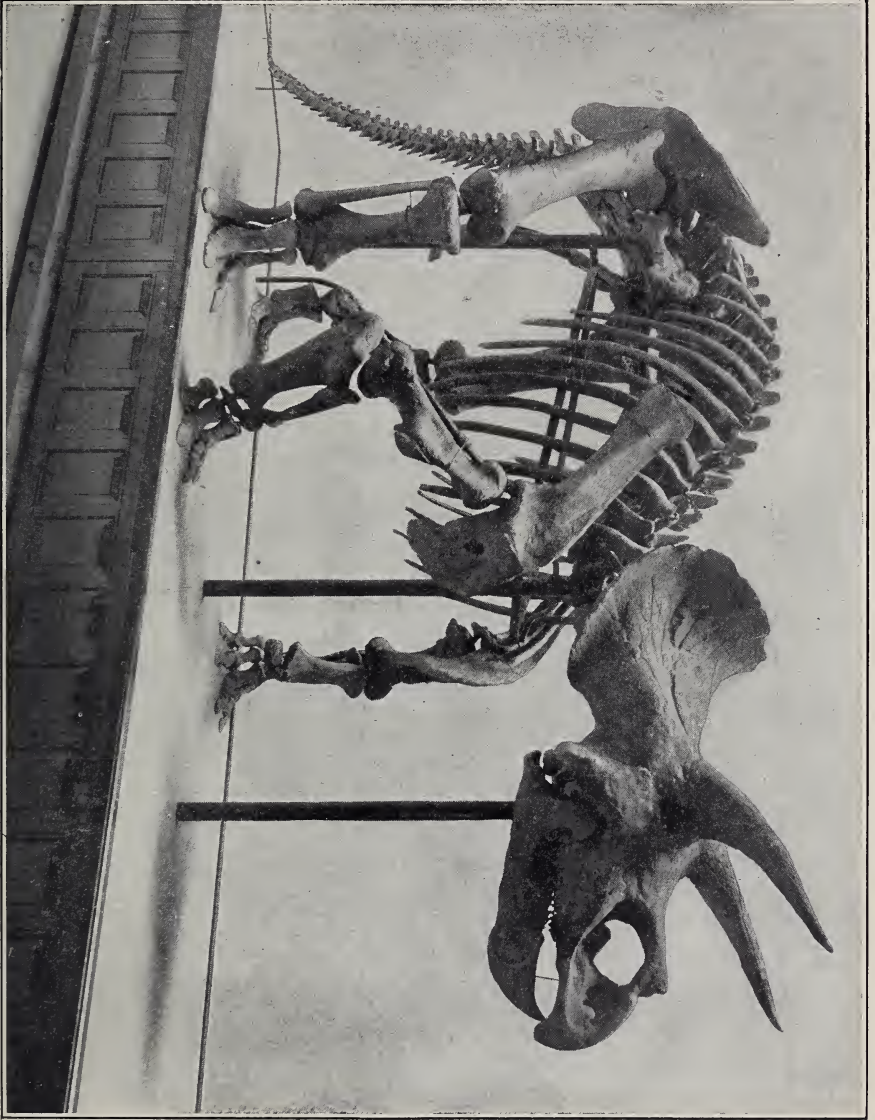



of this enthusiastic student. From this one region he collected the remains of more than forty individuals of the Ceratopsia, a record that has never been equaled.

\* \* \* \* \*

From the tip of the beak to the end of the tail the skeleton as restored is 19 feet 8 inches in length. The skull, which is 6 feet long, equals nearly one-third of this length. At the highest point (the top of the sacrum) it is 8 feet 2 inches above the base. The mounted skeleton presents several features which would otherwise be lost to the observer if seen in the disarticulated condition. The short body cavity, the deep thorax, the massive limbs, and the turtle-like flexure of the anterior extremities are characters only appreciated in the mounted skeleton. The position of the fore limbs in the present mount appears rather remarkable for an animal of such robust proportions, but a study of the articulating surfaces of the several parts precludes an upright mammalian type of limb, as was represented by Marsh in the original restoration. Moreover, a straightened form of leg would so elevate the anterior portion of the body as to have made it a physical impossibility for the animal to reach the ground with its head. . . . In constructing these parts we have followed Marsh's drawing, assisted somewhat by fore-foot material kindly loaned by Dr. H. F. Osborn, of the American Museum of Natural History, New York City.

The nasal horn of the skull used in the present skeleton appears to be missing, and on account of the unsatisfactory evidence as to whether the horn is wholly or only partly gone, it was decided not to attempt a restoration at this time. This will account for the absence of one of the important features upon which the name of the animal is based, *Triceratops* meaning three-horn face, in allusion to the presence of the two large horns above the eyes and the third smaller horn on the nose.

It may be of interest to mention here that Prof. O. C. Marsh used this skeleton (No. 4842), supplemented by other remains now preserved in the collections of the Yale Museum, for the basis of his restoration of *Triceratops prorsus*, published as Plate LXXI in the *Dinosaurs of North America*. . . . A comparison of the above restoration by Marsh with the mounted skeleton [see Plate XV] shows several differences in points of structure, due chiefly to the better understanding of these extinct forms. The most striking dissimilarity is in the shortening of the trunk by a reduction of the number of presacral vertebræ. . . . Mr. Hatcher determined, from a well-preserved vertebral column in the Yale Museum, the number of presacrals as twenty-one, this being six less than ascribed to the animal by Marsh.

## SCIENTIFIC INTELLIGENCE.

## I. CHEMISTRY AND PHYSICS.

1. *A New Formation of Diamond*.—In a lecture delivered before the British Association at Kimberly, South Africa, Sept. 5, 1905, SIR WILLIAM CROOKES stated that he had found what were, in all probability, microscopic diamonds in residues obtained by Sir Andrew Noble in exploding cordite in closed steel cylinders. Crookes had calculated the theoretical melting point of carbon as  $4400^{\circ}$  absolute, and the melting pressure as 16.6 atmospheres; hence he concluded that the conditions of the cordite explosions, where a pressure of 8000 atmospheres and a temperature reaching in all probability  $5400^{\circ}$  absolute, would be favorable for the formation of diamonds. Upon examining the residues from such explosions, octahedral crystals were found which had high index of refraction, the proper cleavage, and the absence of birefringence of the diamond, and, although their other properties have not yet been determined, the chemical ordeal to which they were subjected in the treatment of the material leads to the belief that they must be diamonds.—*Chem. News*, xcii, 148.

H. L. W.

2. *A New Compound of Iron*.—OTTO HAUSER has prepared a curious ammonium-ferrous-ferric basic carbonate, evidently a triple salt, to which he gives the formula

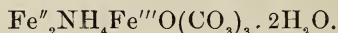

It may be prepared, in the form of a crystalline precipitate, as follows: Ammonium-ferrous sulphate is dissolved in five parts of water, then a solution of commercial ammonium carbonate in about five parts of water is added until the precipitate which forms at first has redissolved. The quickly filtered liquid is then placed in a loosely closed bottle where only a small surface of the solution is exposed to the air. The liquid now becomes brown very rapidly from the top downward without any separation of ferric hydroxide, and in about half an hour a slightly greenish precipitate settles to the bottom, and after about two days the iron is completely removed from the solution in the form of the new compound. The substance has a light green color when fresh, but it rapidly darkens upon exposure to the air. It dissolves readily in acids with effervescence; it gives a black ferrous-ferric oxide with alkalies, and at the same time evolves ammonia.—*Berichte*, xxxviii, 2707.

H. L. W.

3. *Nitrosyl Fluoride*.—RUFF and STÄUBER, by the action of nitrosyl chloride upon silver fluoride have prepared this substance, NOF. It is a colorless gas which melts at about  $-134^{\circ}$  and boils at  $-56^{\circ}$ . In its chemical activity it resembles free fluorine

as well as nitryl fluoride,  $\text{NO}_2\text{F}$ , which has been prepared by Moisson, but from the latter it differs in its density, in reacting readily with iodine to form iodine pentafluoride, and in reacting with water to form nitrous acid instead of nitric acid.—*Zeitschr. Anorgan. Chem.*, xlvii, 190. H. L. W.

4. *The Atomic Weight of Strontium*.—About ten years ago T. W. RICHARDS determined the atomic weight of strontium by means of a comparison of the bromide with silver. He now publishes the results of a comparison of the chloride with silver, made several years ago, but not published at the time on account of a discrepancy in the results due to an unknown cause. This discrepancy has been explained by the recent revision of the relation between silver and chlorine made by Richards and Wells, and it is found that the averages of the two series of determinations agree with remarkable closeness when the correction in the atomic weight of chlorine is made; thus:

$$\begin{aligned} \text{From SrBr}_2, \text{ Sr} &= 87.663 \\ \text{From SrCl}_2, \text{ Sr} &= 87.661 \end{aligned}$$

These results are based on silver as 107.930, but Richards remarks that this number is probably not exact in comparison with oxygen as 16, and that the result will require modification when the true atomic weight of silver has been determined.—*Zeitschr. Anorgan. Chem.*, xlvii, 145. H. L. W.

5. *Qualitative Analysis*; by E. H. S. BAILEY and H. P. CADY. 8vo, pp. 278. Philadelphia, 1905, P. Blakiston's Son & Co.—This book is interesting in being based upon the application of the theory of electrolytic dissociation and the law of mass action; but, however important these principles may be considered in connection with teaching the subject, it appears that the extent to which they are carried in this case often causes a loss of clearness and conciseness as far as qualitative analysis is concerned. It may be mentioned that the book is not as large as its pages would indicate, for nearly half of them are left blank for use in keeping notes. H. L. W.

6. *Charging Effect of Röntgen Rays*.—The ionizing effect of these rays has been apparently fully proved, and there is a satisfactory agreement in the results of observers. This is not, however, true in regard to the question whether the rays give various bodies upon which they impinge electric charges. The subject has been investigated by KARL HAHN, whose results support the contention of Prof. J. J. Thomson, that the rays give a positive charge to bodies. His results are summed up as follows:

(1) All bodies upon which the rays directly impinge are charged positively.

(2) Very thin sheets of metals are charged more strongly than thick sheets, and the difference is greater the shorter the exposure to the rays.

(3) The influence of the character of the metal surface is negligible.

(4) The potential of the charged plate is dependent upon :

(a) The capacity with which the plate is connected ;—the quantity of electricity, that is, the product of capacity and potential is smaller for the greater potential, that is for smaller capacity. If we assume that this is due to the conductivity of the air, one can assume that the quantity of electricity is constant.

(b) The time of exposure to the rays. The potential increases with the time of exposure up to 20 sec. and then remains constant.

(c) On the nature of the rays. Hard rays exert a stronger influence than weak rays.

(d) On the nature of the metals ; the potential is greater the greater the atomic weight, and the more the metal is electronegative. The influence of atomic weight is more notable with the hard rays ; the position of the metals in the electromotive series has greater effect in the case of the weak rays.

(e) On the surrounding gas. The potential is greater in air than in CO<sub>2</sub>.

(5) Secondary rays tend to neutralize the charges. This phenomenon explains the discordant results obtained by various observers.—*Ann. der Physik*, No. 11, 1905, pp. 140-171. J. T.

7. *Emission of Negative Corpuscles by the Alkali Metals*.—Elster and Geitel discovered that even the light emitted by a glass rod heated to a dull red heat was sufficient to cause rubidium to emit corpuscles. Professor J. J. THOMSON shows that rubidium and the liquid alloy of sodium and potassium give out corpuscles in the dark. This result leads Professor Thomson to speculate upon probable differences of temperature between the interiors of bodies and their surfaces arising from the explosion of atoms.—*Phil. Mag.*, Nov. 1905, pp. 584-590. J. T.

8. *A New Method of showing the Presence of Neon, Krypton, and Xenon*.—S. VALENTINER and R. SCHMIDT depart somewhat from the method of Dewar, by which, using the singular occlusion power of charcoal at low temperatures, Dewar showed the presence of neon, hydrogen and helium. Valentiner and Schmidt exhaust the spectrum tube and connected apparatus ; then admit a large quantity of argon, submit this argon to the occlusion action of charcoal at the temperature of liquid air. By this process neon is left in the spectrum tube ; and the quantity can be suitably increased by varying the pressure and amount of exhaustion. Suitable modifications of this method of employing argon as a basis and the occluding power of charcoal at different low temperatures enabled the authors to show the presence of krypton and xenon.—*Ann. der Physik*, No. 11, 1905, pp. 187-197.

J. T.

9. *The Mechanical Properties of Catgut Musical Strings ; a Correction* by J. R. BENTON (communicated).—I have to correct



an error in my article on the Mechanical Properties of Catgut Musical Strings, which appeared in the last issue of this Journal. On page 384, under the heading "Hygroscopic Properties," some observations are discussed which appear to show that the string in question increased in length with increasing humidity; although, as mentioned there, its behavior was much complicated by after-effects. It is well known that the catgut strings of musical instruments are affected by changes of humidity: but they tend to *contract* with increasing humidity, and not to *stretch*, as stated in the article. The string on which I made observations showed just the opposite behavior; but it was under different conditions from the strings in musical instruments. In the first place, it was under far less tension; in the second place, it was free from any torsion; consequently any lateral swelling of its fibers which might occur would have no tendency to shorten it, while such swelling would tend to shorten a twisted string.

## II. GEOLOGY AND MINERALOGY.

1. *Iowa Geological Survey, Volume XV. Annual Report, 1904, with accompanying papers.* FRANK A. WILDER, State Geologist; T. E. SAVAGE, Assistant Geologist. Pp. viii, 560, 7 plates, 51 figures and 10 geological maps. Des Moines, 1905.—The Geological Survey of Iowa, under the charge of Professor Samuel Calvin, has enjoyed an excellent reputation for the thorough and systematic work which it has accomplished since its inauguration. Professor Calvin has now found it necessary to resign from the position of chief responsibility, and the place has been filled by Professor Frank A. Wilder, under whose auspices the present volume has been published. This volume gives promise that the future work done for the State will be carried forward on the same lines and with the same excellent results that have characterized its predecessors.

The volume contains, in addition to the administrative report, a chapter on the Mineral Production in 1904, by S. W. Beyer; another on Cement and Cement Material, by E. C. Eckel and H. F. Bain; and then a series of chapters discussing in detail the geology of a number of counties accompanied by geological maps. These special reports include the following: On the Geology of Benton County, by T. E. Savage; of Emmet, Palo Alto and Pocahontas Counties, by Thomas H. Macbride; of Jasper County, by Ira A. Williams; of Clinton County, by Jon Andreas Udden; of Fayette County, by T. E. Savage. It is stated that the field work for 1905 is being carried on preëminently along economic lines, the earlier stratigraphic work having laid the necessary foundation.

In the report of Mr. Beyer alluded to above, it is shown that the value of the mineral productions of the State in 1904 was

\$15,000,000, of which the chief items are coal, making two-thirds of the whole, and clay more than a fifth; others are building stone, gypsum, lead and sand-lime brick.

2. *Summary Report of the Geological Survey Department of Canada, for the Calendar Year 1904.* ROBERT BELL, Acting Deputy Head and Director. Pp. xxxviii, 392, with seven geological maps. Ottawa, 1905.—This volume gives a concise account of the work accomplished by the Canadian Survey during 1904. The total number of parties engaged was twenty-eight, and their labors extended over the entire area of the country, extending not only from the Atlantic to the Pacific but also into the Arctic. In general, the work carried on, as with other surveys at the present time, was largely on the economic side. As an illustration of what may be accomplished in this way by careful geological work, the Director mentions the recent discovery of a seam of coal, 10 feet thick, at a depth of 2,340 feet, near Pettigrew, in Cumberland County, Nova Scotia. The bore-hole was sunk through an unproductive covering at the suggestion of Mr. Hugh Fletcher of the Survey, as the result of his knowledge of the minute structural geology of that district. This successful result opens the prospect of finding numerous coal seams through an area of fifty miles in length and thirty in breadth. This discovery is given as an illustration of the very important economic results that follow accurate topographical and geological work.

Of the special reports given in the volume, two are devoted to the Kluane and Duncan Creek mining districts, in Yukon Territory, others to the different coal-basins of British Columbia and so on. An interesting account is also given by Commander A. P. Low of the expedition to Hudson Bay and northward in 1903-4 by the S. S. Neptune. Among other points may be mentioned a detailed statement of the phenomena accompanying the fall of the meteorite at Shelburne, Ontario, on August 13, 1904.

3. *Glaciation of Southwestern New Zealand.*—E. C. ANDREWS, of the Department of Mines, Sydney, New South Wales, has written on "Some interesting facts concerning the glaciation of Southwestern New Zealand" (*Trans. Austral. Assoc. Adv. Science*, 1904, 189-205, 8 plates), in which he sets forth with much clearness the evidence of intense glacial erosion in the district of the fiords about Milford sound. Hanging lateral valleys, partially or totally truncated spurs, and the resulting rectilinear cliffs or over-steepened valley sides, with lakes and over-deepened fiords along the valley courses all occur in abundance. These peculiar features are compared with those developed by normal erosion in the highlands of northeastern Australia ("New England"), and the conclusion is reached that as normal erosion cannot possibly account for both, glacial erosion must be responsible for the peculiar features that occur where glaciers are independently shown to have existed. In a supplementary note, Andrews

well says: "The author feels confident that the glacial explanation is most convincing to students of geography, who . . . have not either lived in or even seen any region of former or present intense glaciation. Only to such workers does the whole series of novel perceptions presented during a first glimpse at a former strongly glaciated region come with the startling force of a revelation."

W. M. D.

4. *Mastodon-Reste aus dem interandinen Hochland von Bolivia*; von J. F. POMPECKJ. *Palaeontographica*, Bd. 52, 1905, pp. 17-56, 2 pls.—Dr. Pompeckj, during his travels in Bolivia in 1902, collected near Ulloma and Calacoto a number of mastodon jaws and teeth here described and discussed in great detail. These were found at an elevation of 3800 meters above sea level, and belong to *Mastodon bolivianus* and *M. humboldti*.

The belief is held by some that these mastodons lived at a time when the mountains had a far lower altitude than now, but Pompeckj holds quite the contrary opinion. He states:

"During Diluvial time, or at least during that portion of it when the fauna containing *Mastodon bolivianus* existed, the high Bolivian plains at an elevation of about 3800-4000 meters probably had the character of a steppe, similar to that of to-day, but with a greater rainfall and therefore with a richer growth of grass and bushes than at present.

"Neither the geological structure of the Bolivian highland nor its Diluvial fauna compels the conclusion of decided Diluvial or Postdiluvial elevation of the Andes."

C. S.

5. *Description of New Rodents and Discussion of the Origin of Daemonelix*; by O. A. PETERSON. *Mem. Carnegie Museum*, ii, 1905, pp. 139-191, text figures and pls. 17-21.—The part of this paper of greatest interest in general paleontology relates to the interpretation of the so-called "Devil's corkscrews," so well and fully described by Professor Barbour. The general explanation has been that these gigantic screw casts are the fossilized and infiltrated roots of water plants. However, the suggestion has also been made that they represent the burrows of some fossorial rodent.

Last year Mr. Peterson made a careful search for vertebrate fossils in the *Daemonelix* beds as exposed in the adjoining counties of Sioux in Nebraska and Converse in Wyoming. He states that one is always sure to find rodent remains in a locality where *Daemonelix* is found in great numbers, and he was rewarded in his exploration by securing a number of good skeletons of the beaver-like *Steneofiber* within the spiral of *Daemonelix* or its so-called rhizome. This led him next to study the tunnels of the living prairie-dog so common throughout the semi-arid region of the West. He did this by making a mixture of plaster, water, and sand, and pouring this into and filling the tunnel. Later this filling was dug out, and two of these casts are illustrated in the paper here reviewed; they certainly suggest

*Daemonelix*. The rhizomes of the gigantic corkscrew were found to be either simple or several times branched; some of them ended in an enlargement, but none of them showed small *Daemonelix* spirals emerging from them, as has been stated by other authors. The skeletons within *Daemonelix* are usually scattered "and quite often only the head is found crowded close to the wall, or inside of the rim of the compact mass of roots." The best skeleton was found near the end of one of the rhizomes. Some of the latter attained a length of fifteen feet.

In regard to the plant material found within the spirals, Mr. O. E. Jennings states: "The vegetable tissues are apparently simply the remains of a mesh of roots such as is sometimes found clogging a tile drain or sewer. . . . Enough was evident, however, to plainly indicate that nearly all the roots were those of angiosperms, the cells discerned being quite typical."

The evidence thus far presented is decidedly more in favor of *Daemonelix* being the cast of fossorial rodent burrows than the roots of some gigantic aquatic plant. c. s.

6. *Economic Geology of the Bingham Mining District, Utah*; by JOHN MASON BOUTWELL; with A Section on Areal Geology, by ARTHUR KEITH and An Introduction on General Geology, by SAMUEL FRANKLIN EMMONS. U. S. G. S. Professional Paper, No. 38, 396 pp., 49 pls., 10 figs. in text. — This paper, which almost approaches a monograph in size and scope, is a valuable contribution to the literature of economic geology as well as being a detailed description of an important and interesting mining district. Bingham has been a producing camp since about 1870. In the early days of the district the lead-silver deposits were worked, the carbonate ores being first mined and then later the sulphides. Some gold mining has also been carried on, both placer and vein deposits. In 1896 large bodies of low-grade copper ore were first seriously exploited and since then Bingham has steadily risen in importance as a copper producer. The production of copper from the district for the year 1902 was nearly 15,000,000 lbs.

The Bingham district is situated on the east side of the Oquirrh Mountains about fifteen miles south of Great Salt Lake. The rocks of the section are made up chiefly of quartzites, sandstones and limestones of Upper Carboniferous age, with intrusive bodies of monzonite and monzonite porphyry and extrusive flows of andesite. There is one broad open flexure of the rocks in the district, a synclinal fold which pitches toward the northwest. Besides this many smaller folds are found. The rocks are also extensively faulted.

The ores occur in vein, bedded and disseminated deposits. The vein deposits are chiefly those of argentiferous lead ore which fills fissures that traverse all of the rock types. The bedded deposits are of copper ore and are found in the limestones, while the disseminated copper ore is restricted to the monzonitic intrusives.

The most important ore bodies are those of the copper-bearing sulphide deposits which occur in massive marbled limestones along particular beds in the vicinity of the intrusives.

Mr. Boutwell sums up the geological history of the district as follows: "Between Carboniferous and late Tertiary time monzonitic intrusives invaded sediments in the Bingham area, metamorphosed them and introduced metallic elements which replaced marbled limestone with pyritous copper sulphides. After the superficial portions of the intrusives had cooled to at least partial rigidity they and the inclosing sediments were rent by northeast-southwest fissures.

"Heated aqueous solutions from the deeper unconsolidated portions of the magma then ascended these channels, altered their walls, and introduced additional metallic elements. At this time more pyritous copper sulphide may have been added to that formed earlier in the limestone in connection with contact metamorphism. Monzonite, including its original metallic constituents, was altered; copper, gold and sulphur were probably added, and auriferous copper sulphides were formed. The silver-lead ore was deposited in the fissures, mainly by filling, partly by replacement.

"Since this period of mineralization these original sulphide ores have been altered by surface waters, in their upper portions, into carbonates and oxides, and relatively enriched in their underlying portions."

W. E. F.

7. *Economic Geology, a Semi-Quarterly Journal devoted to Geology as applied to Mining and Allied Industries.* Volume I, Number 1. (Published by the Economic Geology Publishing Company, Lancaster, Pa.)—The appearance of the first number of this new journal is an event of unusual interest and importance. Economic geology has only within the last quarter century established its place as a distinct and important department of geological science. In Germany the *Zeitschrift für praktische Geologie* was the result of this movement among German geologists and it has done much to place this branch of geology on a firm basis both at home and abroad. It is only recently, however, that in the English-speaking world economic geology has begun to occupy its rightful position, and this new journal has been established on account of this fact and with the hope that by its efforts a still larger recognition may be given the subject. Until now the American geologist who had interested himself in the problems of ore deposits had no field for the publication of the results of his investigations outside of the channels of the United States Geological Survey, except in various technical or semi-technical journals devoted to mining. It is, therefore, with a distinct sense of congratulation that we find provided here a proper place for the printing of such papers.

The editor outlines the scope and office of the journal in his first editorial as follows: "The chief purpose of 'Economic Geol-

ogy' will be to furnish its readers with articles of a scientific character. These will deal with the application of the broad principles of geology to mineral deposits of economic value, with the scientific description of such deposits and particularly with the chemical, physical and structural problems bearing upon their genesis. With the engineering and commercial aspects of mining this journal will not be directly concerned, as these subjects find ample representation in the technical mining journals."

The editor of "Economic Geology" is Prof. J. D. Irving of Lehigh University, and the associate editors; Mr. W. Lindgren of Washington, Prof. J. F. Kemp of Columbia University, Mr. F. L. Ransome of Washington, Prof. H. Ries of Cornell University, Mr. M. R. Campbell of Washington and Prof. C. K. Leith of the University of Wisconsin.

The magazine in its mechanical make-up has evidently been modeled after the *Journal of Geology*. The paper, type, and general appearance are all excellent. The first number embraces 100 pages, of which about three-fourths are given to articles, whose titles are as follows: The Present Standing of Applied Geology, by F. L. Ransome; Secondary Enrichment in Ore-Deposits of Copper, by J. F. Kemp; Hypothesis to Account for the Transformation of Vegetable Matter into the Different Varieties of Coal, by M. R. Campbell; Ore-Deposition and Deep Mining, by W. Lindgren; Genesis of the Lake Superior Iron Ores, by C. K. Leith; The Chemistry of Ore-Deposition—Precipitation of Copper by Natural Silicates, by E. C. Sullivan. There are also sections devoted to the informal discussion of topics relating to economic geology, to reviews and to scientific notes and news.

W. E. F.

8. *Minerals in Rock Sections; the practical methods of identifying Minerals in Rock Sections by means of the Microscope*; by LEA McL. LUQUER. Revised Edition. 147 pp. New York, 1905 (D. Van Nostrand Co.).—The additions and changes introduced in the revised edition of this useful volume (see vol. vii, 319) are numerous and such as to materially increase its value for the practical worker with the microscope.

### III. MISCELLANEOUS SCIENTIFIC INTELLIGENCE.

1. *National Academy of Sciences*.—The autumn meeting of the National Academy was held at New Haven, Conn., on November 14 and 15. The following list contains the titles of papers read:

JOHN TROWBRIDGE: Slow movements of electrical discharges.

E. B. WILSON: Sex-determinations and the chromosomes.

L. B. MENDEL: Studies on the chemical physiology of development and growth.

W. M. DAVIS: The Dwyka glacial conglomerate of South Africa.

B. B. BOLTWOOD: The disintegration products of thorium as indicated by the proportions of lead and helium in minerals.

- A. HALL : Relation of the true anomalies in a parabola and a very eccentric ellipse having the same perihelion distance.  
 S. L. PENFIELD : On a new mineral from Borax Lake, California.  
 F. E. BEACH : On errors of excentricity and collimation in the human eye.  
 C. S. PEIRCE : The relation of betweenness and Royce's O-collections.  
 L. P. WHEELER : Some problems in metallic reflection.  
 FRANZ BOAS : On Pearson's formulas of skew distribution of variates.  
 A. AGASSIZ : On the variation in the spines of sea urchins.  
 W. H. BREWER : Further observations on sedimentation.  
 H. A. BUMSTEAD : The effect of Röntgen rays on certain metals.

Recent publications of the Academy are as follows :

Memoirs, Vol. IX.—Monograph of the Bombycine Moths of North America, including their Transformations and Origin of the Larval Markings and Armature. Part II, Family Ceratocampidæ, Subfamily Ceratocampinæ; by ALPHEUS SPRING PACKARD. 149 pp., 61 plates, in part colored.

Vol. X, No. 1.—The Absolute Value of the Acceleration of Gravity determined by the Ring-Pendulum Method; by CHARLES E. MENDENHALL. Pp. 1-23, 3 plates.

No. 2.—Claytonia Gronov, a Morphological and Anatomical Study; by THEODORE HOLM. Pp. 25-37, 2 plates.

No. 3.—A Research upon the Action of Alcohol upon the Circulation; by HORATIO C. WOOD and DANIEL M. HOYT. Pp. 39-68, 3 plates.

2. *The Geological Society of America*.—The eighteenth winter meeting of the Geological Society will be held at Ottawa, Dec. 27-29, in the House of Commons Building; this is by invitation of the Logan Club of the Geological Survey of Canada. President R. Pumpelly will preside. The Cordilleran Section of the Society will meet at Berkeley, Cal., Dec. 29, 30.

3. *A Laboratory Guide in Bacteriology*; by PAUL G. HEINEMANN. 143 pp. 1905 (The University of Chicago Press).—This little manual of 143 pages contains clear and concise directions for a thorough course of laboratory work in the subject, including the preparation of culture and staining media and the collection, isolation, and method of studying the different groups of bacteria. The course, as outlined, is that pursued by the medical students of the University of Chicago. There are descriptions and illustrations of practically every piece of apparatus used in the laboratory. Between each two pages is a blank sheet for notes and additions to the text.

W. R. C.

4. *British Tunicata*; by ALDER and HANCOCK, edited by the Secretary of the Ray Society. Vol. I. Ray Society, 1905. Pp. 146, with 20 plates.—This long delayed monograph, that was begun in 1855, has now made its appearance, more than thirty years after the death of both the authors. The entire work will be completed in three volumes and will contain descriptions and colored illustrations of all the British tunicates known up to the year 1873. The present volume contains a general account of the anatomy, physiology and relationships of the class Tunicata, together with extended specific descriptions of the thirty indige-

nous species of the genus *Ascidia*. Nearly all these forms are illustrated by beautiful colored drawings by the authors. There are also many anatomical figures. W. R. C.

5. *Catalogus Mammalium tam viventium quam fossilium* a Doctore E.-L. TROUËSSART. Quinquennale Supplementum (1899-1904) Fasciculus IV. Pp. vii, 753-929, Berlin, 1905 (R. Friedländer & Sohn).—This part completes the Supplement begun in 1904 (this Journal, xviii, 95) and gives the volume contents and index. It includes the Cetacea, Edentata, Marsupialia, Allothéria, Monotremata.

6. *Carnegie Institution of Washington*.—Recent publications, not before announced, are as follows:

No. 9.—The Collected Mathematical Works of GEORGE WILLIAM HILL. Volume one. Pp. xviii, 363. With an introduction by M. H. Poincaré and a portrait (frontispiece).

No. 35.—Investigations of Infra-red Spectra. Part I, Infra-red Absorption Spectra; Part II, Infra-red Emission Spectra; by WILLIAM W. COBLENTZ. 331 pp., 152 figures, 3 folded plates.

No. 36.—Studies in Spermatogenesis, with especial reference to the "Accessory Chromosome"; by N. M. STEVENS. 30 pp., 7 plates.

No. 37.—Sexual Reproduction and the Organization of the Nucleus in certain Mildews; by R. A. HARPER. 104 pp., 7 plates.

No. 41.—Traditions of the Caddo; collected under the auspices of the Carnegie Institution of Washington; by GEORGE A. DORSEY. 136 pp.

7. *A Handbook of the Trees of California*; by ALICE EASTWOOD, Curator of the Department of Botany. Occasional Papers of the California Academy of Sciences, IX. 86 pp., 57 plates. San Francisco, 1905.—The scope of this work will be seen from the following statement quoted from the preface: "The aim has been to prepare a work which, while giving all the information necessary for the identification of the different trees of our valleys and mountains, will be so brief and concise that the entire matter can be put into a book that can be carried into the field." The description of species are quite brief, but are well supplemented by a series of 57 excellent plates.

#### OBITUARY.

Professor DEWITT BRISTOL BRACE, head of the Department of Physics in the University of Nebraska and author of numerous physical papers, died at his home in Lincoln, Nebraska, on October 2, in his forty-seventh year.

Professor RALPH COPELAND, Astronomer Royal of Scotland and Professor of Astronomy in the University of Edinburgh, died on October 27, at the age of sixty-eight years.

Dr. W. VON BEZOLD, Professor of Physics and Meteorology at the University of Berlin and Director of the German Meteorological Institute, died early in October, in his sixty-ninth year.



# INDEX TO VOLUME XX.\*

## A

- Academy, National, New Haven meeting, 468; publications, 469.  
 Aldrich, J. M., catalogue of No. American diptera, 77.  
 Allen E. T., thermal properties of feldspars, 72.  
 Alpen, die, im Eiszeitalter, Penck and Brückner, 407.  
 American Museum Journal, 77.  
 Arizona, petrography of Tucson Mts., Guild, 313.  
 Ashley, R. H. estimation of sulphites by iodine, 13.

## B

- Bacteriology, Heinemann, 469.  
 Bailey, E. H. S., Qualitative Analysis, 461.  
 Barus, C., groups of efficient nuclei in dust-free air, 297; ions and nuclei in dust-free air, 448.  
 Baskerville, C., phosphorescence of zinc sulphide, 93; action of radium emanations on minerals, 95.  
 Becker, rock cleavage, 407.  
 Belknap Mts., N. H., geology, Pirs-son and Washington, 344.  
 Benton, J. R., properties of catgut musical strings, 383, 462.  
 Bières, Fabrication, Moreau and Lévy, 168.  
 Blondlot's Emission pesante, 400.  
 Bolivia, mastodon remains, Pompeckj, 465.  
 Boltwood, B. B., radium and uranium in radio-active minerals, 55; radio-active waters, Hot Springs, Ark., 128; disintegration products of radio-active elements, 253; production of radium from uranium, 239.

## BOTANY.

- Croomia pauciflora, Holm, 50.  
 Cyperaceæ, studies in the, Holm, No. XXIV, 301.  
 Trees of California, Eastwood, 470.  
 British Museum, Catalogue of Birds' Eggs, Cates, 412.

- Bronson, H. L., effect of temperature on rate of decay of radium deposit, 60.  
 Brown, T. C., Lower Tertiary fauna of Chappaquiddick Is., 229.  
 Brückner, E., die Alpen im Eiszeitalter, 407.  
 Bush, K. J. tubicolous annelids from Pacific, 75.

## C

- Cady, H. P., Qualitative Analysis, 461.  
 Campbell, H. D., Cambro-Ordovician limestones of Virginia, 445.  
 Canada geol. survey, 1904, 464.  
 Canadian Rockies, glacial studies, Scherzer, 80.  
 Cape Colony, Geology, Rogers, 163.  
 Carnegie Institution, publications, 80, 411, 470.  
 Carolinas, tin deposits of, Sterritt and Pratt, 75.  
 Cathode, rotating, for estimation of cadmium, Flora, 268, 392, 455.  
 Chemical Arithmetic, Wells, 399.

## CHEMISTRY.

- Actinium, gases from, Debiere, 319.  
 Aluminium, iodometric determination, Moody, 181.  
 Bromides, typical hydrous, Kreider, 97.  
 Cadmium, estimation of, as sulphate, Flora, 268; as chloride, Flora, 392; as oxide, Flora, 457; by rotating cathode, Flora, 455.  
 Ferric sulphate solutions, hydrolysis of, Recoura, 320.  
 Gold, separation from platinum metals, Jannasch and von Mayer, 320.  
 Helium from radium emanation, Himstedt and Meyer, 399.  
 Hydrogen, liquid, and air calorimeters, Dewar, 152; nascent, diffusion through iron, Winkleman, 400.  
 Iron, new compound, Hauser, 460.

\* This Index contains the general heads, BOTANY, CHEMISTRY (incl. chem. physics), GEOLOGY, MINERALS, OBITUARY, ROCKS, ZOOLOGY, and under each the titles of Articles referring thereto are mentioned.

**CHEMISTRY** *continued.*

- Neon and helium in the air, Ramsay, 65.  
 — krypton and xenon, new method of detecting, Valentiner and Schmidt, 463.  
 Nickel, new reagent for, Tschugaeff, 397.  
 Nitrosyl fluoride, Ruff and Stäuber, 460.  
 Ozone, formation by ultra-violet light, Fischer and Braemer, 397.  
 Precipitates, handling of, Gooch, 11.  
 Radium. See **Radium**.  
 Solution, new heavy, Duboin, 319.  
 Strontium, atomic weight, Richards, 461.  
 Sugar, determination with Fehling's solution, 320.  
 Sulphites, estimation by iodine, Ashley, 13.  
 Thorium, radio-activity of, Sackur, 65.  
 Zinc sulphide, phosphorescence, Baskerville and Lockhart, 95.
- Chemistry, Engineering, Stillman, 398.**  
 Inorganic, Gooch and Walker, 66.  
 Physiological, Long, 399.  
 Qualitative Analysis, Bailey and Cady, 461.
- Cincinnati. See Observatory.**  
**Cleland, H. F.**, formation of natural bridges, 119.  
**Conn, H. W.**, protozoa of Connecticut, 76.  
**Connecticut, clays of, Loughlin, 408.**  
**Crinoids, Helderbergian, of New York, Talbot, 17.**  
**Cummings E. R.**, development of Fenestella, 169.  
**Cushing, H. P.**, geology of Little Falls, N. Y., 156.

**D**

- Daly R. A.**, secondary origin of granites, 185.  
**Darton, N. H.**, age of Monument Creek formation, 178; geology and water resources of Central Great Plains, 70.  
**Davison C.**, Recent Earthquakes, 163.  
**Day, A. L.**, thermal properties of feldspars, 72.

**Dewar, J.**, liquid hydrogen and air calorimeters, 152; thermo-electric junction for determining temperatures, 153.

**E**

- Earthquakes, Recent, Davison, 163.**  
**Eastwood, A.**, Trees of California, 470.  
**Electricity**, side discharge of, Trowbridge, 57.  
**Electrolytic dissociation theory, Talbot and Blanchard, 398.**

**F**

- Fairchild, H. L.**, ice erosion theory, a fallacy, 164.  
**Feldspars, see MINERALS.**  
**FitzGerald-Lorentz effect, Morley and Miller, 67.**  
**Flora, C. P.**, estimation of cadmium as sulphate, 268; do. as chloride, 392; do. as oxide, 457; do. by rotating cathode, 455.  
**Forestry, report for Minnesota, 1904, 167.**  
**Fossils, see GEOLOGY.**

**G**

- Gardiner, J. G.**, Fauna and Geography of the Maldives and Laccadives, Vol. ii, pt. iv, 77.  
**Gas mixtures, Spectroscopic Analysis, Lilienfeld, 67.**  
**Geikie, J.**, Structural and Field Geology, 408.

**GEOLOGICAL REPORTS and SURVEYS**

- Canada, 1904, 464.  
 Cape of Good Hope, 1904, 406.  
 Indiana, 29th annual report, 322.  
 Iowa, Vol. xv, 1904, 463.  
 Louisiana, bulletins, 323.  
 New Jersey, 1904, 323.  
 United States, 69, 402.

**Geological Society of America, Ottawa meeting, 469.**

**GEOLOGY.**

- Baptanodon, osteology, Gilmore, 403.  
 Bingham mining district, Utah, geology, Boutwell, Keith and Emmons, 466.  
 Cambrian faunas of India, Walcott, 404, 405.

**GEOLOGY** *continued.*

- Cambrian, Lower, fauna of, Portugal, Delgado, 159.  
 Ceratopsia, two new, Wyoming, Hatcher, 413.  
 Chazy limestone, fauna of, Raymond, 353.  
 Clays of Connecticut, Loughlin, 408.  
 Daemonelix, origin of, Peterson, 465.  
 Diceratops, restoration, Lull, 420.  
 Faults, overthrust, in central New York, Schneider, 308.  
 Fenestella, development, Cumings, 169.  
 Fossil Invertebrates, Catalogue, U. S. Nat. Museum, Schuchert, 405.  
 Geologic map of Tully Quadrangle, Clarke and Luther, 158.  
 Geology of Bingham mining district, Utah, Boutwell, 466; of Central Great Plains, Darton, 70; of Little Falls, N. Y., Cushing, 156; of Littleton, New Hampshire, Hitchcock, 161; of Watkins and Elmira quadrangles, Clarke and Luther, 157.  
 Glacial conglomerate of South Africa, Mellor, 107.  
 — studies, Canadian Rockies, Scherzer, 80.  
 Glaciation of the Green Mts., Hitchcock, 166; of New Zealand, Andrews, 464.  
 Glacier, Delavan lobe of Lake Michigan, Alden, 409.  
 Graptolites of New York, Ruedemann, 406.  
 Helderbergian crinoids of New York, Talbot, 17.  
 Ice erosion theory, fallacy of, Fairchild, 164.  
 Limestones, Cambro-Ordovician of Virginia, Campbell, 445.  
 Martinez group, paleontology, Weaver, 159.  
 Mastodon remains from Bolivia, 465.  
 Mesozoic plants from Korea, Yabe, 406.  
 Monument Creek formation, age of, Darton, 178.  
 Natural bridges, formation, Cleland, 119.  
 Paraphorhynchus, new brachiopod, Weller, 160.  
 Peat bogs of Switzerland, Früh and Schröter, 162.

**GEOLOGY** *continued.*

- Rock cleavage, Leith, 406, Becker, 407.  
 Sympterura minveri, Devonian ophiurid, Bather, 160.  
 Tertiary, Lower, fauna of Chappaquiddick Island, Brown, 229.  
 Thalattosauria, California, Merriam, 161.  
 Toxocheleys, new Niobrara, Wieland, 325.  
 Triassic system in New Mexico, Keyes, 423.  
 Triceratops prorsus, mounted skeleton, Schuchert, 458.  
 Turtles, marine, new, Wieland, 325; Upper Cretaceous, Wieland, 430.  
 Unionidæ, origin of No. American, White, 160.  
 Vaileys, hanging, Russell, 165.  
**Geology**, Economic, Journal of, 467.  
 — of Cape Colony, Rogers, 163.  
 — Structural and Field, Geikie, 408.  
 Gilmore, C. W., osteology of Baptanodon, 403.  
**Glaciation, Glaciers**, see **GEOL-  
 OGY**.  
 Gooch, F. A., handling of precipitates for solution and reprecipitation, 11, Inorganic Chemistry, 66.  
 Graton, L. C., purpurite, new mineral, 146.  
 Green Mts., glaciation, Hitchcock, 166.  
 Guild, F. W., petrography of the Tucson Mts., Arizona, 313.

**H**

- Harrington, B. J., apparatus for vapor densities, 225.  
 Harvard College, see **Observatory**.  
 Hatcher, J. B., two new Ceratopsia, Wyoming, 413.  
 Heinemann, P. G., Laboratory Guide in Bacteriology, 469.  
 Hidden, W. E., cassiterite, a new cleavage, 410.  
 Hitchcock, C. H., glaciation of the Green Mts., 166.  
 Hobbs, W. H., origin of channels around Manhattan Island, 71.  
 Hofmeister, F., Beiträge zur chem. Physiologie, 168.  
 Holm T., Croomia pauciflora, 50; studies in the Cyperaceæ, XXIV, Carices from N. W. America, 301.

Hough, R. H., mechanical equivalent of heat vaporization of water, 81.

Howorth, H. H., Ice or Water, 166.

## I

Ice or Water, Howorth, 166.

Iddings, J. P., optical study of the feldspars, 72.

India, Cambrian faunas of, Walcott, 404, 405.

Indiana, geol. survey, 322.

Ions and nuclei in dust-free air, Barus, 448.

Iowa, geol. survey, 1904, 463.

## J

Jamieson, G. S., tychite, 217.

Japan, magnetic survey, Tanakadate, 167.

## K

Kayser, H., Handbuch der Spectroscopie, 69.

Keyes, C. R., Triassic system in New Mexico, 423.

Kilimandjaro to Meru, Africa, Uhlig, 78.

Korea, Mesozoic plants from, Yabe, 406.

Kreider, D. A., iodine titration voltmeter, 1.

Kreider, J. L., typical hydrous bromides, 97.

## L

Laboratoire de l'Usine, Houlevigue, 168.

Lakes, A., Geology of Western Ore Deposits, 409.

Landolt-Börnstein Physikalisch-Chemische Tabellen, 401.

Leith, J. B., rock cleavage, 406.

Littleton, N. H., geology, Hitchcock, 161.

Lockhart, L. B., action of radium emanations on minerals, 95; phosphorescence of zinc sulphide, 93.

Long, J. H., Physiological Chemistry, 399.

Loughlin, G. F., Clays of Connecticut, 408.

Louisiana geol. survey, bulletins, 323.

Lull, R. S., restoration of Dicera-tops, 420.

Luquer, L. McI., Minerals in Rock Sections, 463.

## M

Magnetic survey of Japan, Tanakadate, 167.

Maldives and Laccadives, Fauna and Geography, Gardiner, 77.

Manhattan Island, origin of channels around, Hobbs, 71.

Manila, ethnological survey, publications, 167.

Mastodon remains from Bolivia, Pompeckj, 465.

Mellor, E. T., glacial conglomerate of South Africa, 107.

Merriam, J. C., Thallatosauria from California, 161.

Metals, emission of negative corpuscles by alkali, Elster and Geitel, 461.

## MINERALS.

Beckelite, 323. Bowmanite, 324.

Cassiterite, new cleavage, 410.

Diamond, formation, Crookes, 460. Enargite, 280.

Feldspars, thermal properties, Day and Allen, 72; optical study, Iddings, 72.

Hematite, N. J., 283. Hutchinsonite, 324.

Lengenbachite, 324. Luzonite, 277. Marrite, 324.

Northupite, 217.

Platinum in black sands, Day, 410. Purpurite, 146.

Quartz, San Diego Co., Cal., 125.

Riebeckite, genesis, 133.

Smithite, 324. Sylvanite, 282.

Tin deposits of the Carolinas, Pratt and Sterrett, 75. Trechmannite, 324. Tychite, 217.

Wolframite, Boulder, Colo., 281.

Minerals, action of radium emanations on, Baskerville and Lockhart, 95.

— in Rock Sections, Luquer, 468.

— optical character of birefracting, Wright, 285.

— radio-active, Rutherford and Boltwood 55; Strutt, 68.

Montana, Agricultural College, Science Studies, 78.

— petrography of Central, Pirsson, 35.

Moody, S. E., iodometric determination of aluminium, 181.

Murgoci, G. M., riebeckite and riebeckite rocks, 133.

Musical strings, properties of, Benton, 383, 462.

## N

- Negritos of Zambale, Reed, 167.  
 New Hampshire, geology of, Pirsson and Washington, 344.  
 New Jersey geol. survey, 1904, 323.  
 New Mexico, Triassic system, Keyes, 423.  
 New York, graptolites of, Ruedemann, 406.  
 — Helderbergian crinoids, Talbot, 17.  
 — overthrust faults in central, P. F. Schneider, 308.  
 New Zealand, glaciation, Andrews, 464.  
 Nobel prizes in 1902, 167.  
 Nuclei, efficient, in dust-free air, Barus, 297.

## O

## OBITUARY.

- Von Bezold, W., 470; Brace, D., 470; Buckton, G. B., 412.  
 Copeland, R., 470.  
 Errara, L., 412.  
 Reclus, E., 412.  
 Von Richthofen, F., 412.  
 Observatory, Cincinnati, 411; Harvard College, 411; Mt. Wilson, Cal., 80; West Hendon House, 80; Yerkes, 411.  
 Optical character of birefracting minerals, Wright, 285.  
 Ore deposits, Geology of western, Lakes, 409.

## P

- Pacific, tubicolous annelids from, Bush, 75.  
 Palæontologia Universalis, 406.  
 Penck A., die Alpen im Eiszeitalter, 407.  
 Penfield, S. L., tychite, 217.  
 Peterson, origin of Daemonelex, 465.  
 Physikalisch-chemische Tabellen, Landolt-Börnstein, 401.  
 Physiologie, Beiträge zur chem. Hofmeister, 168.  
 Pirsson, L. V., petrographic province of Central Montana, 35; geology of New Hampshire, 344.  
 Portugal, Lower Cambrian fauna, Delgado, 159.  
 Pumpelly, R., Explorations in Turkestan, 245.

## Q

- Quartz apparatus for laboratory purposes, Mylius and Meusser, 66.  
 — permeability to gases, Berthelot, 66.

## R

- Radio-active elements, disintegration products, Boltwood, 253.  
 — minerals, Rutherford and Boltwood, 55; Strutt, 68.  
 — waters, Hot Springs, Ark., Boltwood, 128.  
 Radio-activity, absence of excited, due to temporary exposure to  $\gamma$ -rays, 68; of thorium, Sackur, 65.  
 Radium, action of emanations on minerals, Baskerville and Lockhart, 95.  
 — effect of temperature on rate of decay of deposit from, Bronson, 60.  
 — emanations, helium from, Himstedt and Meyer, 399.  
 — production from uranium, Boltwood, 239.  
 — slow transformation products, Rutherford, 321.  
 — and uranium in radio-active minerals, Rutherford and Boltwood, 55.  
 Ramsay, neon and helium in air, 65.  
 Raymond, P. E., fauna of Chazy limestone, 353.

## ROCKS.

- Andesites, Arizona, Guild, 314.  
 Basalt, Arizona, Guild, 316.  
 Belknap Mts., N. H., Pirsson and Washington, 344.  
 Granites, secondary origin of, Daly, 185.  
 Petrographic province of Central Montana, Pirsson, 35.  
 Quartz-basalt, Arizona, Guild, 318.  
 Rhyolite, Arizona, Guild, 313.  
 Riebeckite rocks, genesis, Murgoci, 133.  
 Rock cleavage, Leith, 406; Becker, 407.  
 Rogers, A. W., Geology of Cape Colony, 163.  
 Röntgen rays, charging effects, Hahn, 461.  
 Rutherford, E., radium and uranium in radio-active minerals, 55; slow transformation products of radium, 321.

## S

- Shaller, W. T., purpurite, a new mineral, 146.  
 Schneider, H., Soils and Fertilizers, 398.  
 Schneider, P. T., overthrust faults in central New York, 308.

- Schuchert, C., Catalogue of Fossil Invertebrates, U. S. Museum, 405; mounted skeleton of *Triceratops prorsus* in U. S. Nat. Museum, 458.  
 Sedgwick, A., text-book of Zoology, 76.  
 Smithsonian Institution, annual report, 412.  
 Soils and Fertilizers, Schneider, 398.  
 South Africa, glacial conglomerate, Mellor, 107.  
 Spectral lines, influence of character of excitation upon structure, 68.  
 Spectroscopie, Handbuch, Kayser, 69.  
 Stillman, T. B., Engineering Chemistry, 398.  
 Switzerland, peat bogs of, Früh and Schrötter, 162.

## T

- Talbot, M., revision of the New York Helderbergian Crinoids, 17.  
 Taschenberg, O., *Bibliotheca Zoologica*, II, 412.  
 Temperatures, thermo-electric junction for determining, Dewar, 153.  
 Trouessart, E. L., *Catalogus Mammalium*, 470.  
 Trowbridge, J., side discharge of electricity, 57.  
 Tully quadrangle, geologic map, Clarke and Luther, 158.  
 Turkestan, Explorations in, 245.

## U

- Uhlig, C., Kilimandjaro to Meru, Africa, 78.  
 United States, geol. survey, 69, 402. National Museum, Report for 1903, 167.  
 — — Catalogue of Fossil Invertebrates, Schuchert, 405.  
 Utah, geology of Bingham mining district, Boutwell, Keith and Emmons, 466.

## V

- Vapor-densities, apparatus for determining, Harrington, 225.  
 Virginia, Cambro-Ordovician limestones, Campbell, 445.  
 Voltaic element, normal, 68.  
 Voltmeter, iodine titration, Kreider, 1.

## W

- Walcott, C. D., Cambrian faunas of India, 404, 405.  
 Walker, C. F., *Inorganic Chemistry*, 66.  
 Walther, J., *Geology*, 161.  
 Waring, G. A., quartz from San Diego Co., California, 125.  
 Water, heat vaporization, mechanical equivalent, Hough, 81.  
 Watkins and Elmira quadrangles, geology, Clarke and Luther, 157.  
 Washington, H. S., geology of Belknap Mts, N. H., 344.  
 Wells, H. L., *Text-book of Chemical Arithmetic*, 399.  
 Wieland, G. R., new Niobrara *Toxochelys*, 325; Upper Cretaceous turtles, 430.  
 Wright, F. E., optical character of birefracting minerals, 285.  
 Wyoming, new *Ceratopsia*, Hatcher, 413; restoration of *Diceratops*, Lull, 420.

## Y

- Yerkes Observatory, report, 411.

## Z

- Zoologica*, *Bibliotheca*, II, Taschenberg, 412.  
 Zoology, text-book, Sedgwick, 76.

## ZOOLOGY—

- Annelids, tubicolous, from the Pacific, Bush, 75.  
 Birds' Eggs, catalogue, British Museum, Oates, 412.  
 Cold Spring Harbor Monographs, 78.  
 Diptera, No. American, catalogue, Aldrich, 77.  
 Fauna of Maldives and Laccadives, Gardiner, 77.  
 Goat, Rocky Mt., Grant, 77.  
 Insects, Habits and Instincts, Fabre, 77.  
 Mammalium, Catalogus, Trouessart, 470.  
 Protozoa of Connecticut, Conn. 76.  
 Tunicata, British, Alder and Hancock, 469.

# MERELY A REMINDER

THIS PAGE is occupied by us merely as a reminder that the only concern in America which can supply you with

SPECIMENS IN ALL DEPARTMENTS OF NATURAL HISTORY

(Except Botany and Entomology)

IS

## Ward's Natural Science Establishment

To our old friends, the leading museums, colleges, educators and private collectors of the world, we are continually offering new things, some of which will be announced at the bottom of this page, from time to time. We endeavor to always remember you with our latest circulars; if you have failed to receive these recently, a line from you will bring them by return mail.

To those who have not formerly dealt with us,—our establishment was founded in 1862, and incorporated in 1890 as a stock company with a paid-up capital of \$125,000. We occupy a frontage of 250 feet facing the University of Rochester, and are known from the Yukon to the Ganges as the largest institution in the world dealing in Natural History Specimens. For over forty years we have made it our sole business to collect, prepare and sell these, individually or in collections. Quality rather than extreme cheapness is our aim, and we have spared no expense to maintain a high standard and a standing in scientific circles. We pay no commissions, but deal direct with our customers, and sell at list prices only. We offer school collections as low as \$5 and have made one cabinet costing over \$100,000 (Field Columbian Museum, Chicago), and seventeen others ranging from \$10,000 to \$70,000. In numerous instances we have built a large public museum complete at one stroke. Our catalogues, over twenty in number, are not mere price-lists, but are valuable as reference works, and have even been used as text-books in academies and colleges. A small charge is made for these, except to our regular customers or teachers intending to purchase; a list will be sent upon request. We also issue free circulars in all departments, and shall be glad to place your address on our mailing list.

### OUR DEPARTMENTS.

*Mineralogy* (Minerals, Rocks, Crystal Models, Meteorites, etc.).  
*Geology* (Phenomenal Series, Relief Maps, Geological Models).  
*Palaeontology* (Fossils, Casts of Celebrated Fossils, Wall Charts, etc.).  
*Archaeology and Ethnology* (Specimens, Models, Casts of Monuments).  
*Invertebrates* (Shells, Echinoderms, Corals, etc.; Biological Supplies).  
*Zoology* (Mounted Skins and Skeletons, Custom Work in Taxidermy).  
*Human Anatomy* (Human Skeletons, and Anatomical Models of all kinds).

### SPECIAL ANNOUNCEMENT FOR THIS MONTH.

Out of Print.—Our well-known "CATALOGUE OF MOLLUSCA" will shortly be out of print, less than 100 copies remaining. This elaborate book of 150 pages and 200 illustrations will not be reissued. Send forty cents for a copy before it is too late.

Ward's Natural Science Establishment,

76-104 COLLEGE AVENUE, ROCHESTER, N. Y.

CONTENTS.

	Page
ART. XLI.—Two New Ceratopsia from the Laramie of Converse County, Wyoming; by J. B. HATCHER. (With Plates XII, XIII.)	413
XLII.—Restoration of the Horned Dinosaur Diceratops; by RICHARD S. LULL. (With Plate XIV.)	420
XLIII.—Triassic System in New Mexico; by CHARLES R. KEYES	423
XLIV.—Structure of the Upper Cretaceous Turtles of New Jersey: Agomphus; by G. R. WIELAND	430
XLV.—The Cambro-Ordovician Limestones of the Middle Portion of the Valley of Virginia; by H. D. CAMPBELL	445
XLVI.—Relations of Ions and Nuclei in Dust-free Air; by CARL BARUS	448
XLVII.—Additional Notes upon the Estimation of Cadmium by Means of the Rotating Cathode, and Summary; by CHARLES P. FLORA	454
XLVIII.—The Estimation of Cadmium as the Oxide; by CHARLES P. FLORA	456
XLIX.—The Mounted Skeleton of Triceratops prorsus in the U. S. National Museum; by C. SCHUCHERT. (With Plate XV.)	458

SCIENTIFIC INTELLIGENCE.

*Chemistry and Physics.*—A New Formation of Diamond, SIR W. CROOKES: A New Compound of Iron, OTTO HAUSER: Nitrosyl Fluoride, RUFF and STÄUBER, 460.—The Atomic Weight of Strontium, T. W. RICHARDS: Qualitative Analysis, E. H. S. BAILEY and H. P. CADY: Charging Effect of Röntgen Rays, KARL HAHN, 461.—Emission of Negative Corpuscles by the Alkali Metals, J. J. THOMSON: A New Method of Showing the Presence of Neon, Krypton, and Xenon, S. VALENTINER and R. SCHMIDT: The Mechanical Properties of Catgut Musical Strings, J. R. BENTON, 462.

*Geology and Mineralogy.*—Iowa Geological Survey, Volume XV, 463.—Summary Report of the Geological Survey Department of Canada, R. BELL: Glaciation of Southwestern New Zealand, E. C. ANDREWS, 464.—Mastodon-Reste aus dem interandinen Hochland von Bolivia, J. F. POMPECKJ: Description of New Rodents and Discussion of the Origin of Daemonelex, O. A. PETERSON, 465.—Economic Geology of the Bingham Mining District, Utah, 466.—Economic Geology, 467.—Minerals in Rock Sections, L. MCL. LUQUER, 468.

*Miscellaneous Scientific Intelligence.*—National Academy of Sciences, 468.—The Geological Society of America: A Laboratory Guide in Bacteriology, PAUL G. HEINEMANN: British Tunicata, ALDER and HANCOCK, 469.—Catalogus Mammalium tam viventium quam fossilium, E. L. TROUSSERT: Carnegie Institution of Washington: A Handbook of the Trees of California, A. EASTWOOD, 470.

*Obituary.*—Professor DEWITT BRISTOL BRACE, Professor RALPH COPELAND, Professor D. W. VON BEZOLD, 470.

INDEX TO VOL. XX, 471.

**TEN-VOLUME INDEX.**

An *extra number*, containing a full Index to volumes XI to XX of the Fourth Series, will be ready in December or January. Sent only to those who specially order it. Price one dollar.

313





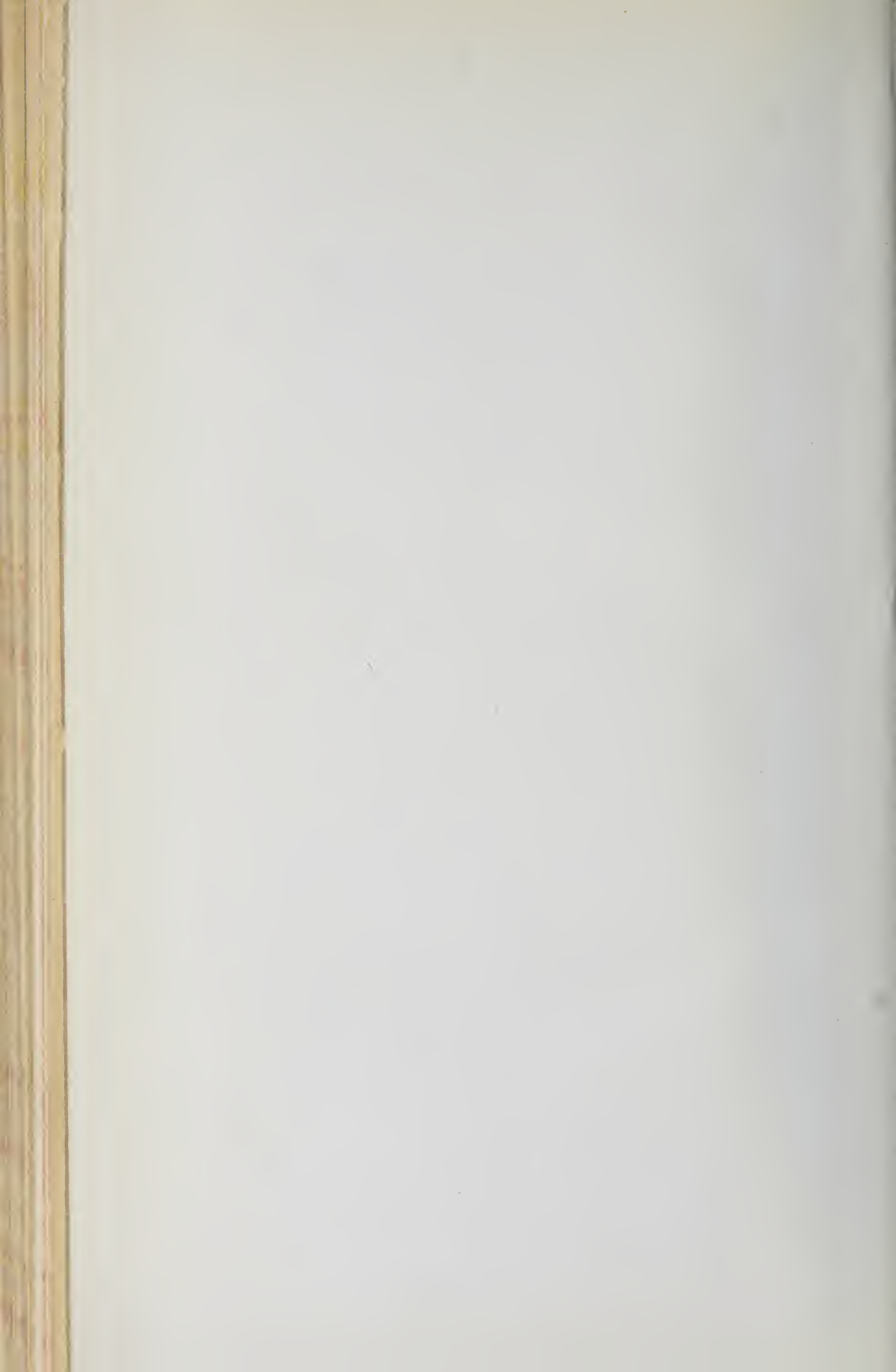







SMITHSONIAN INSTITUTION LIBRARIES



3 9088 01298 5719