

TH 5670
.669

AMERICAN
STAIR BUILDERS'
GUIDE.

LIBRARY OF CONGRESS.

TH5670

Chap. Copyright No.

Shelf ... Q 69

UNITED STATES OF AMERICA.







THE
AMERICAN
Stair-Builders' Guide,

BY
LUCIUS D. GOULD.

Illustrated by 32 Original Plates.

~~30~~
9 2 15

75413

NEW YORK:
A. J. BICKNELL & CO.
1875.

TH 670
G 69

~~TH 670
G 69~~

Entered according to Act of Congress, in the year 1875, by
LUCIUS D. GOULD,
In the Office of the Librarian of Congress, at Washington.

PRINTED BY
JENNINGS & HARDHAM,
NEWARK, N. J.

8-4170

PREFACE.

To invent and draw a system of stair-railing superior to any heretofore published, is claimed to be impossible. But after a careful examination of the systems now in use, the author of this work finds that they are not faultless, but susceptible of improvements, as will be demonstrated and proved to the satisfaction of every one who will carefully examine the plates, and peruse the descriptive matter shown in this work.

To furnish such drawings and explanations of the several parts of stairs and railing, as can be comprehended by workmen not versed in the science, nor much experienced in the construction of stair-railing, and as will enable them to execute with accuracy the most difficult designs it is necessary to study simplicity, both in the drawings, and in the terms used for their explanation. In what follows, we shall aim to do this in such a manner that the inexperienced workman will find no difficulty in understanding the plates and the description thereof.

NEWARK, N. J., }
August, 1875. }

Plate 1

Illustrates a few of the principles that govern the operation of constructing the face mould for the wreaths, and should be thoroughly understood by the workman, as he will FIRST draw the *elliptical curves* required for the mould, then find the point of contact of the straight wood with the curve and the length required.

To form an Ellipse with a thread or string.

Make A B (Figure 1) the long diameter or major axis, and C D half the short diameter or minor axis of the required ellipse. From the point D as centre, with C B as radius, describe arcs, cutting the major axis at 2 and 3; at the points, place pins; around the pins, place a cord so fastened at the ends that it shall reach around 2 D 3; place your pencil inside the cord and describe the ellipse A D B R. Care should be taken to keep the cord to an even tension. Suppose the elliptic curve A D B to be the centre of a mould required for a wreath, set off each way from D half the width of the rail, and draw the dotted lines D 2 and D 3. From the points S and H draw lines parallel to D 2 and D 3 to intersect the major axis. At the points thus found, place pins and describe the outside and inside curves. To draw two elliptical curves parallel to each other, set off from R to J, equal to B N, from the point J as centre, with C N as radius, describe arcs, cutting the major axis at A and B, the points for the pins to describe the curve required.

Figure 2 shows the method of finding the point to bore for the first baluster on the second step, when you have the length of the newel and the length of the short baluster given. Let A be the pitch-board and 2 the centre of the newel-post; make 3 4 equal to the difference between the lengths of the newel-post and short baluster. Square over from 4 to the under-side of newel-cap, and where the line 3 4 intersects the underside of rail will be the point to bore for the baluster. To continue the same height of rail from the starting to its termination, care should be taken to rise from the point B to C, equal to the height of the rise on the second flight; bisect the rise in D for the underside of the level rail.

Fig. 1.

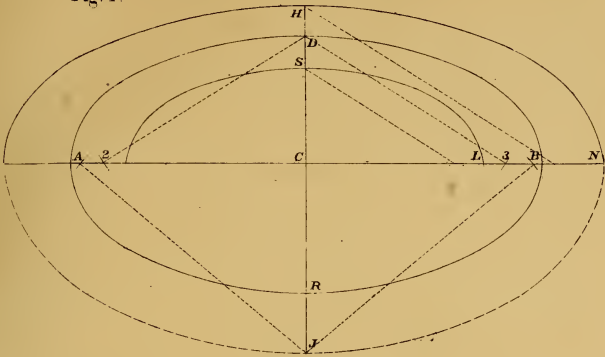
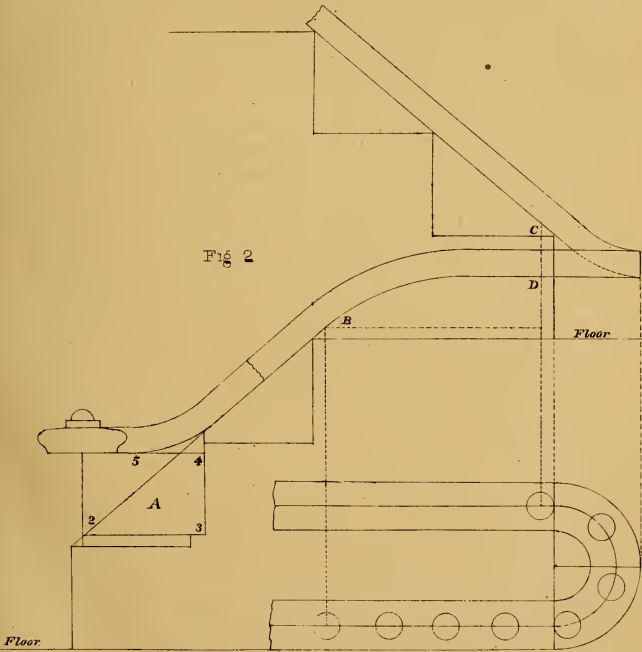

Fig 2



Scale inch - 1foot

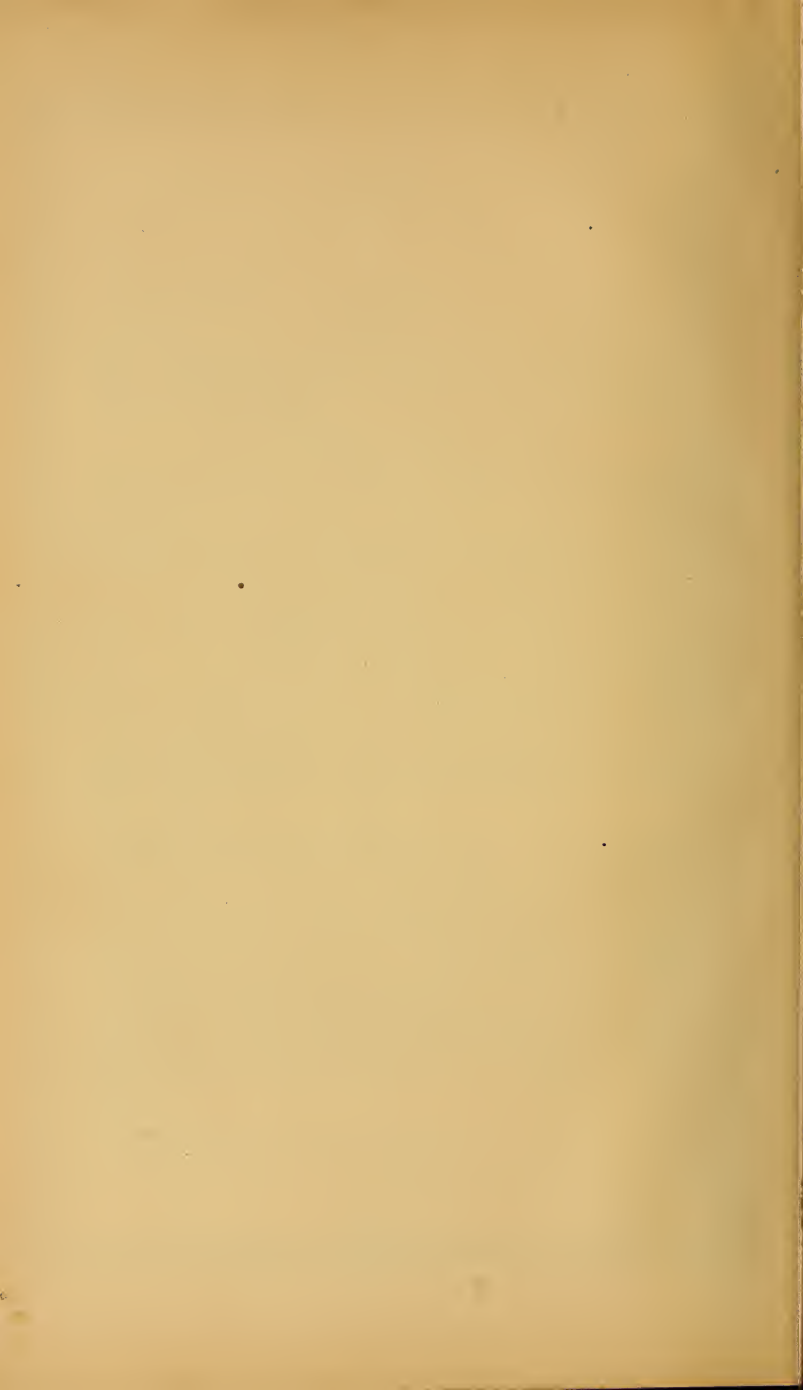



Plate 2

Exhibits the ground plan and elevation of the hand-rail for a platform staircase.

Figure 2, shows the method of forming the mould for the wreath. Draw A B, the pitch or inclination of the stairs. Square up from A and B, equal to C D, Fig. 1. Set off from C to B equal to the width of the rail. To find the points for the pins, to describe the elliptical curves for the outside and inside of the mould; from the points S and C as centres, with S 2 and C 3 as radii, describe arcs, cutting the line A B at 5 4 and 3 2, the points required. The application of the spring-bevel, shown at Fig. 3, is seen at the joint A, which gives the angle to draw the centre line and determine the thickness of plank required for the wreath. The plank sawed square, the straight wood one-fourth inch wider than the rail, apply the mould, as shown at Fig. 4, mark the curves on both sides. To remove the corner A, tack the mould on the opposite side of the plank. The same operation will be required to remove the corner B. The saw or plane should be held in the direction of the centre line shown at the joint. Screw the wreaths together and place them over the pitches on the drawing-board, as shown at Fig. 3. Find the points C and D, from which gauge the thickness of the rail and form the wreath.

This system can be applied to large cylinders by extending the radius from C to N and leaving the risers the same distance from the centre of the rail, as shown by the dotted lines at Fig. 1.

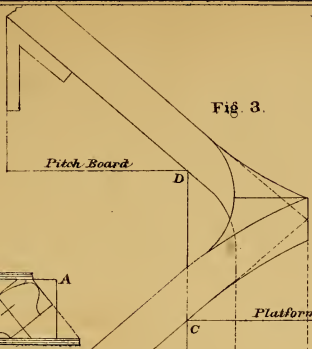

Fig. 4.

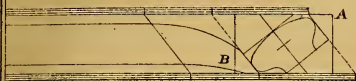

Fig. 2.

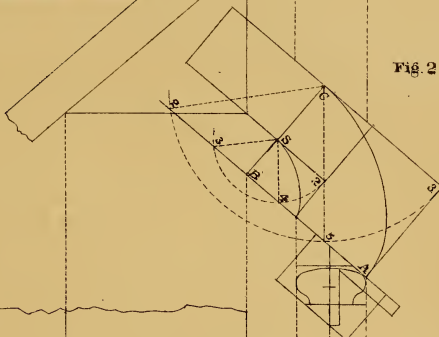
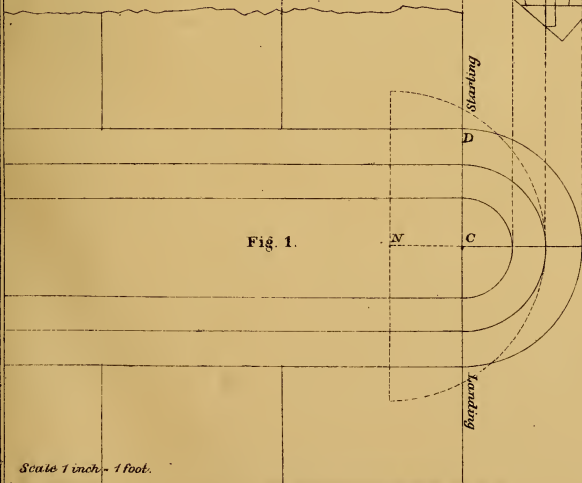

Fig. 1.



Scale 1 inch = 1 foot.





Plate 3

Exhibits the ground plan and elevation for a quarter landing; also the method of determining the length of curve required for the mould.

To draw the elevation, produce the radius A C, Fig. 1, to B, Fig. 2. From the point B, draw the pitch and floor lines, indefinitely. From the centre of the baluster, shown at A, Fig. 1, draw the dotted line parallel to A B, cutting the pitch line at J. Set up from J to P, equal to half the height of riser for the centre of level rail. Draw D T parallel to B A. Then A T, Fig. 1, is the length of the tangents, and A S is the length of curve required.

In works heretofore published on stair-railing, the authors have given geometrical methods, of finding the spring bevels for the joints, which may or may not be correct; the only evidence of their correctness, being ascertained by their application, which in our method is practically made before the mould is drawn, as the width of the mould, and thickness of the plank, are determined by the bevels, which can be found by taking a piece any thickness and forming the angle A T S, Fig. 1. Draw T L at right angles to A T, and L D, the pitch of the stairs. Draw L C at right angles to L T. Work to the lines, and apply the bevels. The bevel at C is for the joint. The bevel applied to the pitch line L D, is for the straight wood.

We will now state to the workman, that the minor or short axis of the elliptic curve, required for the mould, must in all cases, be equal to the radius of the circle given on the plan. The length of the major or long axis, is governed by the angle, to which the cylinder may be cut, as follows: Draw A B, Fig. 1, at right angles to A S, equal to S D, Fig. 2; produce the circle from A to R; draw C D parallel to A B; join S B and extend to R. Then D R equals half the length of the major axis, and S B determines the length of curve required for the mould.

The above rule will in all cases be found true, as we shall prove in the following plates.

The mould for the wreath is shown at Fig. 3. Draw the major axis indefinitely. To find the points for the pins, to describe the centre curve, set off from C to B, equal to D R, Fig. 1. From the point A, as centre, with C B, as radius, describe arcs cutting the major axis at 2 and 3, the points required. To find the length of curve, from the point B as centre, with S B, Fig. 1, as radius, describe an arc, cutting the curve at D, the length required. For the direction of the straight wood, draw D S, equal to B D, Fig. 2, and B S, equal to A T, Fig. 1; then S D is the direction required. For the width of the mould, set off from A each way half the width of the rail; at Fig. 2, set off from 2 to 3, the width of the rail, draw 3 4 at right angles to 2 3; then 4 5 is the width of the mould at B. The points for the pins to describe the outside and inside curves, are found in the same manner as those for the centre curve; the plank sawed square to a parallel width from the centre curve, one-fourth inch wider than the rail; cut the joints at right angles to the tangents. The application of the bevels are shown at Fig. 3, and give the direction of the centre line, from which the section of rail is formed at the joints. At right angles to the joints draw lines from H and B on both sides of the plank; then place the centre of the mould on the line H D, squared from the joint, and move the mould until the line B S stands over the line squared from the joint B. Mark the plank for the corners to be removed. The same operation is required for the opposite side. Tack the mould on the opposite side of the corner to be removed. In doing this, the saw or plane should be held in a vertical direction. The surplus wood can be removed from the upper and lower sides of the wreath, after tracing the thickness of the rail from the centre of the plank.

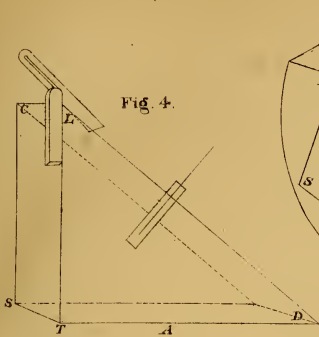

Fig. 4.

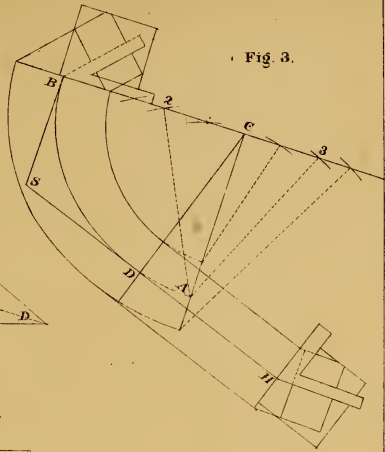

Fig. 3.

Fig. 2.

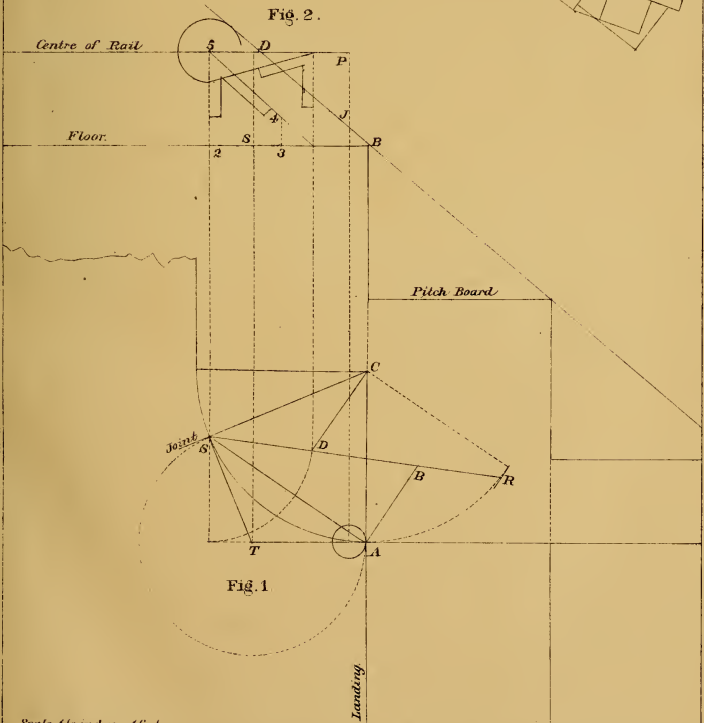

Fig. 1.

Scale 1 1/2 inches = 1 foot.





Plate 4

Exhibits the ground plan for a platform staircase; also a very simple and easy method of forming the face mould for the wreath; the plank sawed square to a parallel width.

The face-mould for the wreath, at Fig. 3, is found by first getting the length of the major axis, and describing the elliptical curves; next, the point of contact, from that the length of curve required. The length of the major axis is obtained by drawing B S, Fig. 1, at right angles to B H, equal to H R, Fig. 2. Produce the circle from B to E. Draw C J and E D parallel to B S; then J D equals half the length of the major axis, and H S determines the length of curve, required for the mould.

For the mould, at Fig. 3, draw a line indefinitely; square up from A to C, equal to C H, the radius of the circle at Fig. 1; set off each way, from the point C, half the width of the rail. To find the points for the pins, from the point C as centre, with J D as radius, describe arcs, cutting the major axis at 2 and 3, the points for the pins, to describe the centre curve. The points, for the pins to describe the outside and inside curves, are found by drawing the dotted lines parallel to C 2 and C 3, to intersect the major axis at the points required. To find the point of contact, draw H J equal to 2 3, Fig. 2, from the point J, as centre, with H S, Fig. 1, as radius; describe an arc cutting the curve at S, the point of contact of the straight wood with the circle. To find the direction of the straight wood, draw J K equal to R P, Fig. 2, and S K equal to T P, Fig. 2. Draw A S, and from its intersection with the curves, draw the straight wood parallel to K S, indefinitely. The joints are cut at right angles to the tangents. The bevel, for the straight wood, is shown at P; for the joint at H, Fig. 2.

Another example of the practical method of finding the spring bevels for the joints: Fig. 4 shows a piece formed to fit the angle B G H, Fig. 1; draw G S at right angles to G B; draw S B the same pitch or inclination as P T, Fig. 2, and S P the same pitch as P R, Fig. 2; apply the bevels at right angles to the pitch lines. The bevel on the line S P, is for the joint at J; the one on the line S B, is for the joint on the straight wood.

Fig. 3.

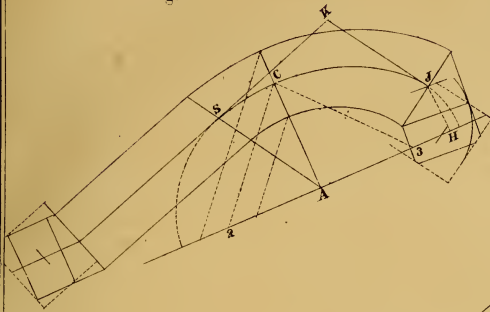
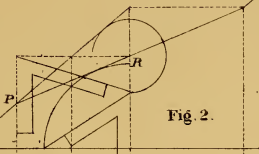

Fig. 2.



Pitch Board

Pitch Board

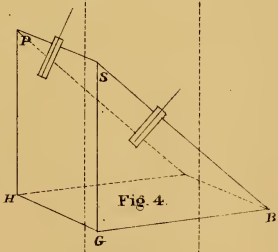
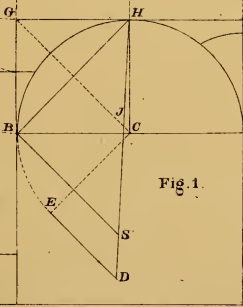

Fig. 4.

Starting

Landing

Fig. 1.



Scale 1 1/2 inches = 1 foot.





Plate 5

Exhibits the ground plan of the turn-out at the starting of a staircase, the wreath forming its own easing at the newel.

Before drawing the mould it is necessary to know the height of the newel, which is seven inches higher than the short balusters; or, suppose the short baluster to be two feet from the top of the step to the underside of the rail, and the newel two feet seven inches from the top of first step to the underside of newel-cap, then at Fig. 2 set up from the top of first step seven inches to the centre of rail. To find the position of the steps, from the point B, draw the common pitch indefinitely; set up from the first step the height of one riser, cutting the pitch line at C, the point for the riser, which determines the position of the steps on the plan. The radius of the curve will be governed by the projection of the newel, from the face of string. The length of curve will be determined by the width of steps and the height of newel.

Find the major axis of the elliptic curve for the centre of the face-mould by drawing S D, Fig. 1, at right angles to S B, equal to L G, Fig. 2; produce the circle from S to R; draw R P and C H parallel to S D; join B D and extend to P. Then H P equals half the length of the major axis and B D determines the length of curve required for the mould.

For the face-mould. At Fig. 3 draw the major axis; square up from the point C to B, equal to C S, Fig. 1. To find the points for the pins, to describe the centre curve, from the point B as centre, with C D as radius, describe arcs, cutting the major axis at 2 and 3, the points required. To find the length of curve, and point of contact, from the point D as centre, with B D, Fig. 1, as radius, describe an arc, cutting the curve at N, the point and length required. The direction of the straight wood is given by drawing D S equal to B L, Fig. 1, and N S equal to G B, Fig. 2. For the width of the mould set off each way from B half the width of the rail. At Fig. 2 make 2 3 equal to the width of the rail; draw 3 4 at right angles to 2 3. Then 2 4 is the width of the mould at D. The points for the pins to describe the outside and inside curves, are found in the same manner as those for the centre curve.

Figure 4 exhibits a practical method of finding the spring-bevels for the joints, by fitting a piece of wood to the angle of the tangents on the plan. From the point L, draw the line L C at right angles to L S; draw C D at right angles to C L, and C R, the pitch of the stairs; apply the bevels at right angles to the lines, C D and C R. The bevel on the line C D, is for the joint D, and is shown at 3, Fig. 2. The bevel on the pitch-line C R is for the straight wood, and is shown at 4, Fig. 2.

Fig. 3.

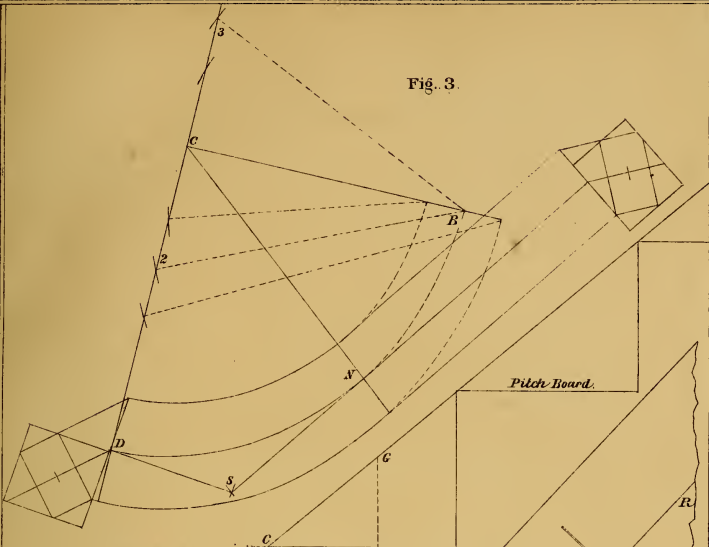

Fig. 2.

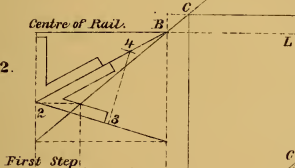

Fig 4

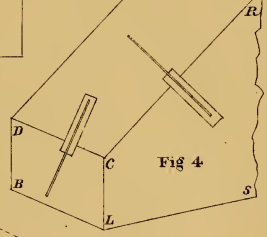
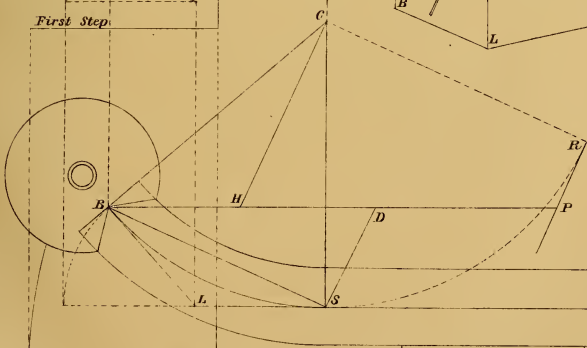

Fig. 1.



Scale 1 1/2 inches = 1 foot.





Plate 6

Exhibits the plan and elevation for the turnout at the starting of the staircase, the rail terminating against the newel; the plank sawed square to a parallel width.

The length of the major axis is found by producing the curve D A, Fig. 1, to T; draw T J and A S parallel to C B; make A S equal to R N, Fig. 2; join D S and extend to J. Then P J equals half the length of the major axis, and D S determines the length of the curve required for the mould.

At Fig. 3 draw the major axis indefinitely; square up from C to B equal to C D, Fig. 1. The points, for the pins to describe the centre curve, are found by taking in the compasses the distance P J, Fig. 1, with the point B as centre, and describing arcs, cutting the major axis at 2 and 3, the points required. The length of curve, and the direction of the straight wood, is found by making C S equal to C B, Fig. 1. From the point S as centre, with H N, Fig. 2, as radius, describe arcs, cutting the curve at D and H; join S H and S D. Then H D is the length of curve, and S D the direction required. The width of the mould is found by setting off each way from B, half the width of the rail; the points from which to describe the outside and inside curves. The points for the pins, are found by drawing the dotted lines parallel to B 2 and B 3 to intersect the major axis. The joints are cut at right angles to the tangents. One bevel answers for both joints.

Fig. 2.



Fig. 1.

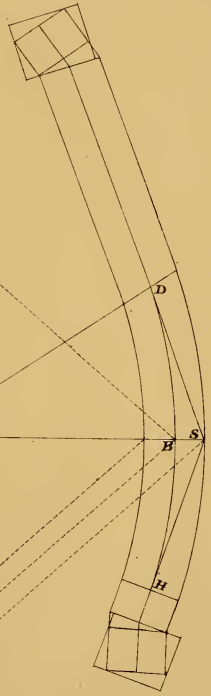

Fig. 3.

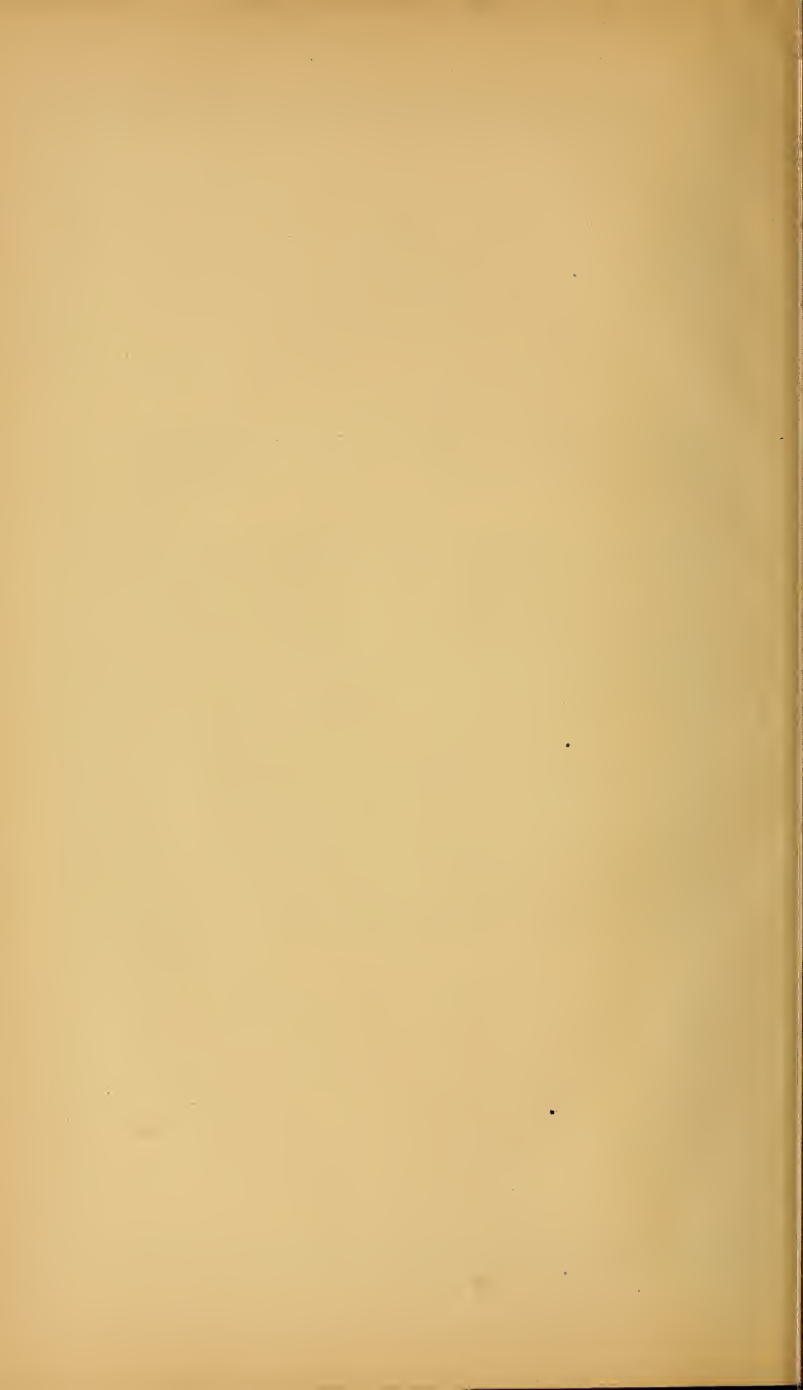



Plate 7

Exhibits the ground plan of an elliptical turnout at the starting of the staircase; the mould formed by ordinates; the plank sawed square, and the joints made at right angles to the face of plank.

The workman will first draw the elliptical curve required for the turnout, and attach the newel cap; then place the steps as shown at Fig. 1. At Fig. 2 is shown the elevation of the steps and risers, which gives the common pitch. Set up from the first step to the centre of rail, the difference in the heights of the newel post and short baluster, which is $6\frac{1}{2}$ inches; draw C L at right angles to A H; make the tangent A B, Fig. 1, equal to C L, Fig. 2. From the point B, Fig. 1, draw the tangent B D indefinitely.

To form the mould for the wreath, draw D S, Fig. 1, at right angles to B D, and A S parallel to B D; set up from D to R equal to L H, Fig. 2; join R S. At right angles to R S, draw R T, equal to D B, Fig. 1, and S J equal to S A, Fig. 1; join J T, which should equal C H, Fig. 2; draw any number of ordinates from the plan; transfer the distances, and trace the mould. The bevel for the straight wood is shown at Fig. 2, and is found by drawing D F at right angles to A B, Fig. 1; then by extending F D to intersect the pitch line at Fig. 2; from the point of intersection, square over to K; then P K will equal D F, Fig. 1. From the point P as centre, describe an arc, touching the pitch line, which determines the angle for the bevel required.

H

Fig. 2

L

C Centre of Rail

K

P

First Step

J

T

Fig. 3.

R

S

D

A

H

F

Fig. 1.

Scale 1 1/2 inches = 1 foot.

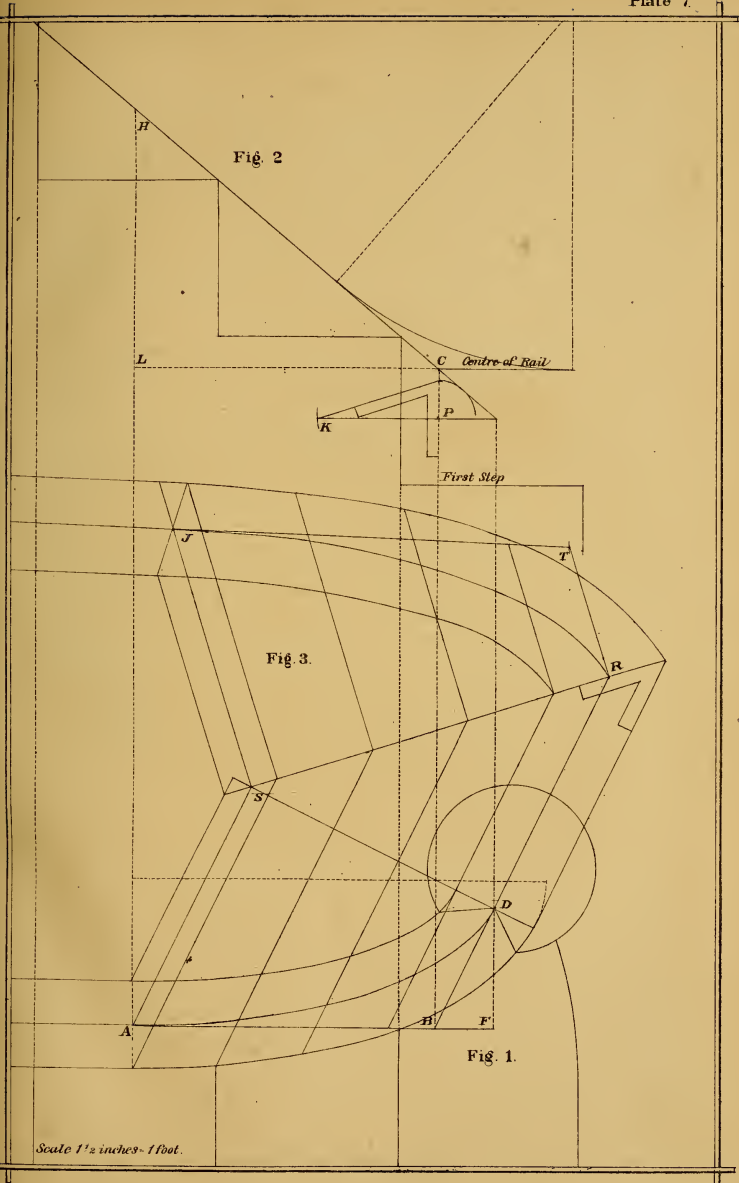

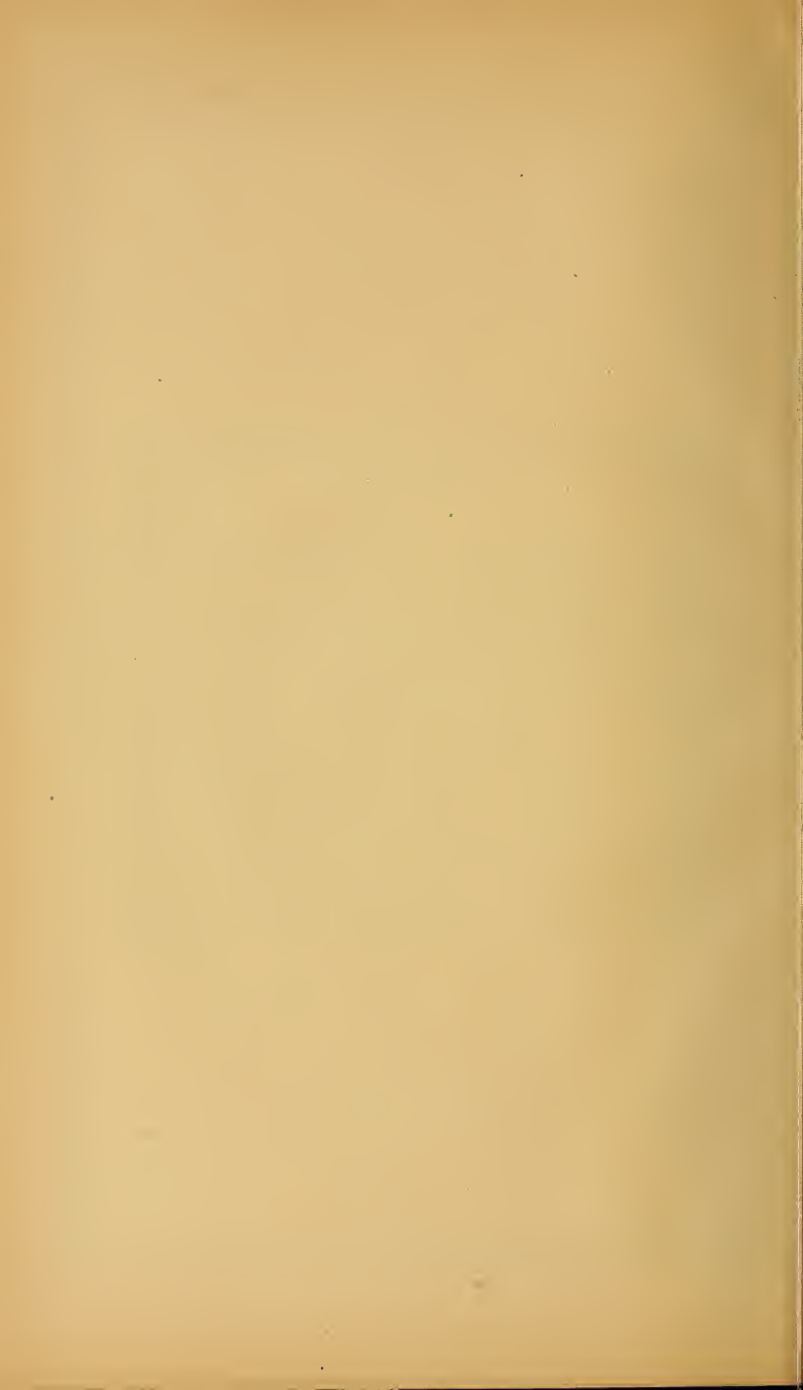



Plate 8

Exhibits the plan for a staircase, starting with winders; the circle produced beyond a quadrant; the plank sawed square to a parallel width, the wreath forming its own easing at the newel.

At Fig. 2, set up from the first step to the centre of rail, the difference in the heights of the newel and short baluster, find the height from the first step, to the first square step above the winders, which is six risers. Place the pitch-board and draw the common pitch indefinitely. Draw the easing, so as to have about three inches of straight wood to the wreath. Then from the point A, draw the pitch line, tangent to the curve in the rail, which completes the elevation.

The length of the major axis is found at Fig. 1, by producing the curve D A to T, and drawing A B and T R parallel to C S; make A B equal to C J, Fig. 2; join D B and extend to R. Then S R equals half the length of the major axis or long diameter, of the elliptic curve required for the centre of the mould.

For the mould, at Fig. 3 draw the major axis indefinitely; square up from C to D, equal to C D, Fig. 1. For the width of the mould, set off each way from D half the width of the rail. The points, for the pins to describe the centre curve, are found by taking the point D as centre, with S R, Fig. 1, as radius, and describing arcs, cutting the major axis at 2 and 3, the points required. The points, for the pins to describe the outside and inside curves, are found by drawing the dotted lines, parallel to D 3 and D 2 to intersect the major axis. The length of curve, and direction of the straight wood, is found by extending the line C D to S equal to C N, Fig. 1, from the point S as centre, with R J, Fig. 2, as radius; describe an arc, cutting the curve at J, the length required; join S J and extend to P; then S J is the direction, and J P the length of straight wood required. The bevel for the joint at the newel, is shown at R. The bevel, for the straight wood, is shown at K.

Fig. 2.

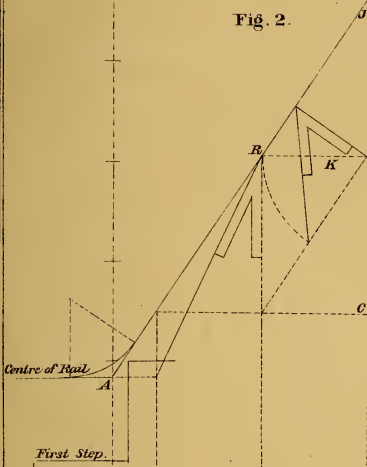

Pitch Board

Fig. 3.

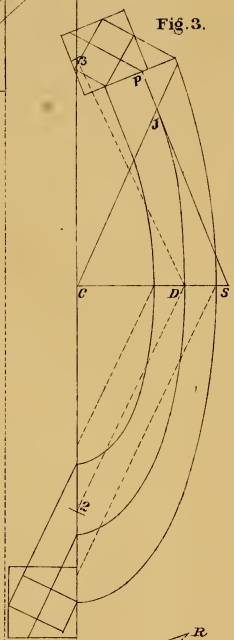
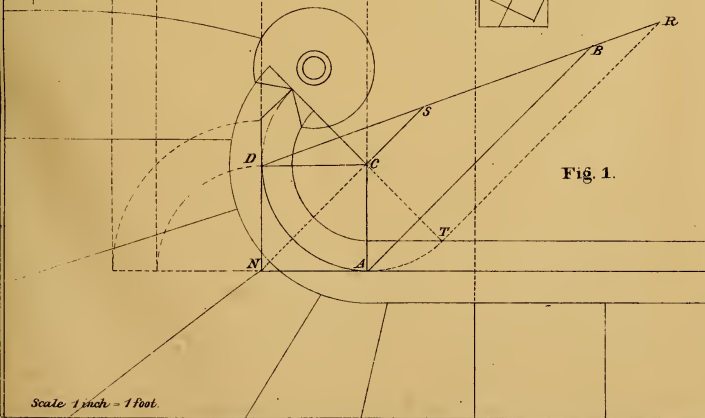

Fig. 1.



Scale 1 inch = 1 foot.

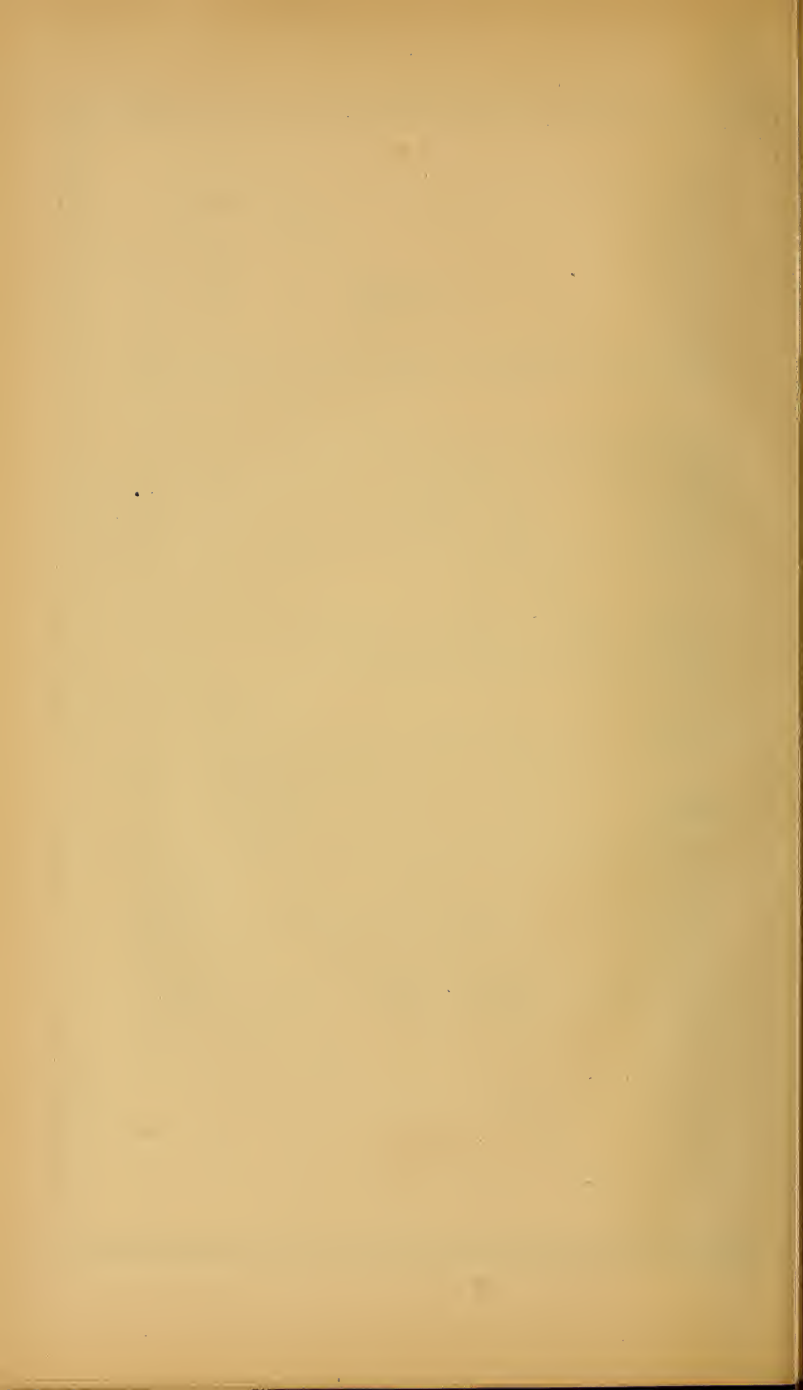



Plate 9

Exhibits the ground plan and elevation for a staircase, starting with winders; the curve is drawn from centres of unequal radii.

Set up from the first step to the centre of rail, the difference in the heights of the newel and the short baluster. To find the length of the major axis of the elliptic curve for the centre of the mould, draw lines from D and A, Fig. 1, parallel to C H, indefinitely; set up from D to R, equal to B C, Fig. 2; draw B R, and extend to S. Then J S equals half the length of the major axis for the centre of the mould at Fig. 3.

To form the mould, draw the major axis, indefinitely. To find the points for the pins, square up from C to B, equal to C D, Fig. 1. From the point B as centre, with J S, Fig. 1, as radius, describe arcs, cutting the major axis at 2 and 3, the points required. For the direction of the straight wood and length of curve, set up from C to P, equal to C H, Fig. 1. From the point P as centre, with L S, Fig. 2, as radius, describe arcs, cutting the curve at R and H; join P R and P H; then P H is the direction, and R H the length of curve required. For the width of the mould, and the points for the pins, to describe the outside and inside curves, set off each way from B half the width of the rail; from the points draw lines parallel to B 2 and B 3, to intersect the major axis. The bevel for the joints is shown at Fig. 2.

The face mould for the quadrant at the newel is shown at Fig. 4; square up from A to B equal to B 3, Fig. 1; set off from A to C equal to S B, Fig. 2. From the point B as centre, with A C as radius, describe arcs, cutting the line A C at 2 and 3; the points for the pins to describe the centre curve. For the width of the mould, and the points for the pins to describe the outside and inside curves, set off each way from B half the width of the rail. From the points draw lines parallel to B 2 and B 3 to intersect the line A C. The bevel for the joint C is shown at S, Fig. 2.

Fig. 3.

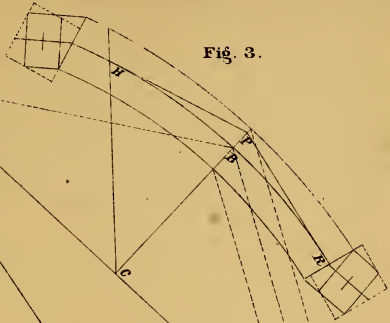

Fig. 4.

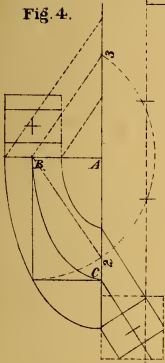

Fig. 2.

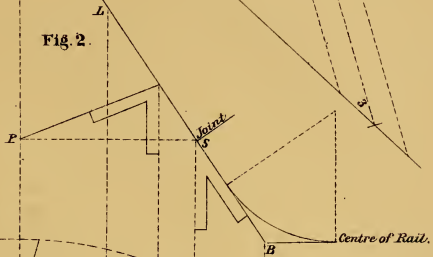
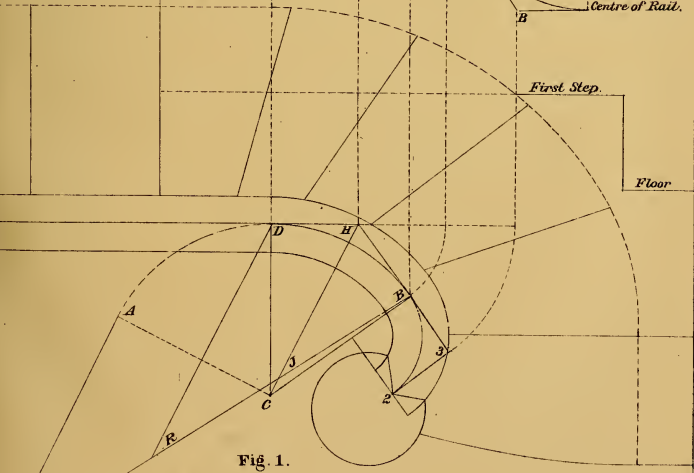

Fig. 1.



Scale 1 inch - 1 foot.





Plate 10

Exhib ts the ground plan and the elevation for a staircase, starting with wind-ers; the curve drawn from centres of unequal radii; the wreath in one piece forming its own easings.

Set up from the first step to the point N, equal to the difference in the heights of the newel, and the short baluster; join R N; square over from N to Y; draw Y V parallel to the centre of rail; join R V, and extend to P. Then H P equals half the major, and V Y half of the minor, axis of the quadrant at the starting.

To find the length of the major axis of the elliptic curve, for the centre of the mould, draw lines from the points B and L, Fig. 1, parallel to C P, indefinitely; set up from B to R equal to D G, Fig. 2; draw A R and extend to D. Then J D equals half the length of the major axis, and A R determines the length of curve required.

To form the mould at Fig. 3, draw the major axis indefinitely. To find the points for the pins; to describe the centre curve, square up from C to D, equal to C B, Fig. 1. From the point D as centre, with J D, Fig. 1, as radius, describe arcs, cutting the major axis at 2 and 3, the points required. For the point to cut the curve, set up from the major axis equal to 2 3, Fig. 1; from that point draw a line parallel to the major axis, cutting the curve at T. From the point T as centre, with A R, Fig. 1, as radius, describe an arc, cutting the curve at N. Then T N is the length of curve required for the mould standing over the curve B A, Fig. 1. For the extension of the mould over the quadrant at the starting, square over from N to A equal to V Y, Fig. 2; draw A B parallel to H N, equal to H P, Fig. 2. To find the points for the pins to describe the centre curve from N to B, take A B as radius, from the point N as centre, describe arcs, cutting the line A B, for the points required. For the width of the mould, set off each way from D half the width of the rail. At Fig. 2, 2 3 and 4 5 each equals the width of the rail; then 6 3 equals the width of the mould at T, and R 5 equals the width of the mould at B. To find the points for the pins, to describe the outside and inside curves from T to D, set off each way from 2 and 3 equal to T K. The points for the pins, to describe the outside and inside curves from N to B, are found in the same manner as those for the centre curve. The bevel for the straight wood is shown at 6; for the joint B, at R.

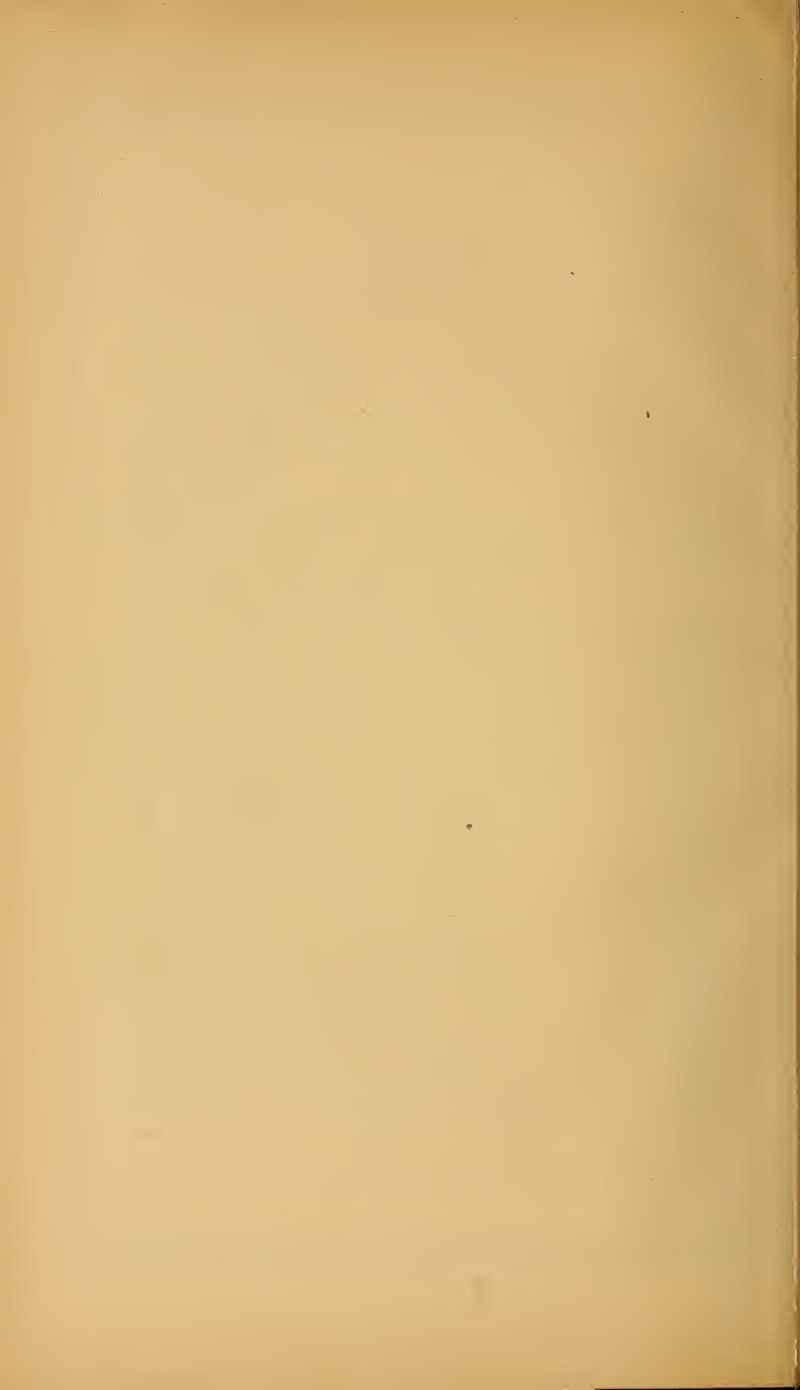



Plate 11

Exhibits the ground plan for a quarter platform staircase; the risers placed at the spring of the cylinder.

To find the major axis of the elliptic curve for the centre of the mould, draw $H B$, Fig. 1, parallel to $C A$, equal to $S C$, Fig. 2; produce the curve $T H$ to J ; draw $T B$ and extend to J . Then $D J$ equals half the length of the major axis, and $T B$ determines the length of curve required.

At Fig. 3 draw the major axis indefinitely; square up from C to B equal to $C T$, Fig. 1. To find the points for the pins to describe the centre curve, take $D J$, Fig. 1, as radius, from the point B as centre, describe arcs, cutting the major axis at 2 and 3, the points required. To find the point, to cut the curve, set up from the major axis, equal to $R S$, Fig. 1; from the point, draw a line, parallel to the major axis, cutting the curve at 5. From the point 5 as centre, with $T B$, Fig. 1, as radius, describe an arc, cutting the curve at L , the point of contact, and the length of curve required. For the direction of the straight wood, draw H , equal to $C D$, Fig. 2, and $L H$ equal to $B D$, Fig. 2. Extend $H L$ any length required. This being an arbitrary case, it is necessary to find the bevels, (which in all cases govern the width of the mould,) which are shown at Fig. 2. At Fig. 4 they are enlarged; the dotted line 2 3 equals the width of the rail; then 2 4 equals the width of the straight wood at L , and 6 5 the width of the mould at the joint. The points for the outside and inside curves are found by setting off each way from B , half the width of the rail, from the point N , set off each way half the length of 6 5, Fig. 4; then 4 5 and 6 7 are the points from which to draw the curves. The points for the pins are found by taking in the compasses $C 5$ as radius, from the point 6 as centre, and describing arcs, cutting the major axis, at the points required for the inside curve. The pins for the outside curve are found in the same manner. The joints are cut square with the tangents.

Fig. 3.

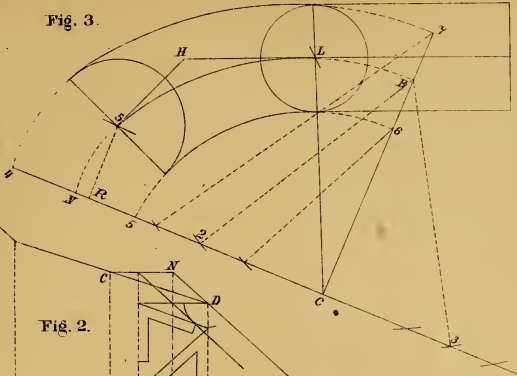
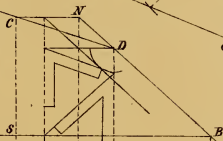
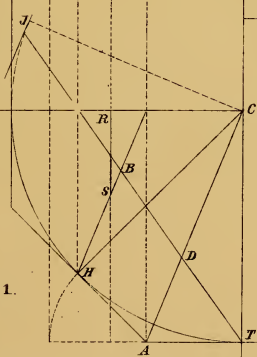

Fig. 2.



Starting

Fig. 1.



Pitch Board



Fig. 4.

Landing





Plate 12

Exhibits the ground plan and elevation of the platform, for an acute angled staircase; the wreath in one piece; the plank sawed square to a parallel width.

To find the length of the major axis of the elliptic curve for the centre of the mould, draw lines from the points A and J, Fig. 1, parallel to C F; set up from A to D, equal to S R, Fig. 2; draw R D and extend to E; then E G equals half the length of the major axis, and R D determines the length of the curve required for the mould.

For the mould at Fig. 3, draw the major axis indefinitely. To find the points for the pins, to describe the centre curve, square up from C to L equal to C R, Fig. 1. From the point L as centre, with G E, Fig. 1, as radius, describe arcs, cutting the major axis at 2 and 3, the points required. To find the point to cut the curve, set up from the major axis equal to 2 3, Fig. 1; from the point, draw a line parallel to the major axis, cutting the curve at J. From the point J as centre, with R D, Fig. 1, as radius, describe an arc, cutting the curve at R. For the direction of the straight wood, draw R H equal to N H, Fig. 2, and J H equal to R H, Fig. 2. For the width of the mould, and the points for the pins to describe the outside and inside curves, set off each way from L half the width of the rail. From the points draw lines parallel to L 2 and L 3 to intersect the major axis. The joints are cut square with the tangents, and face of plank. The bevel for the joint R is shown at N; for the straight wood at H.

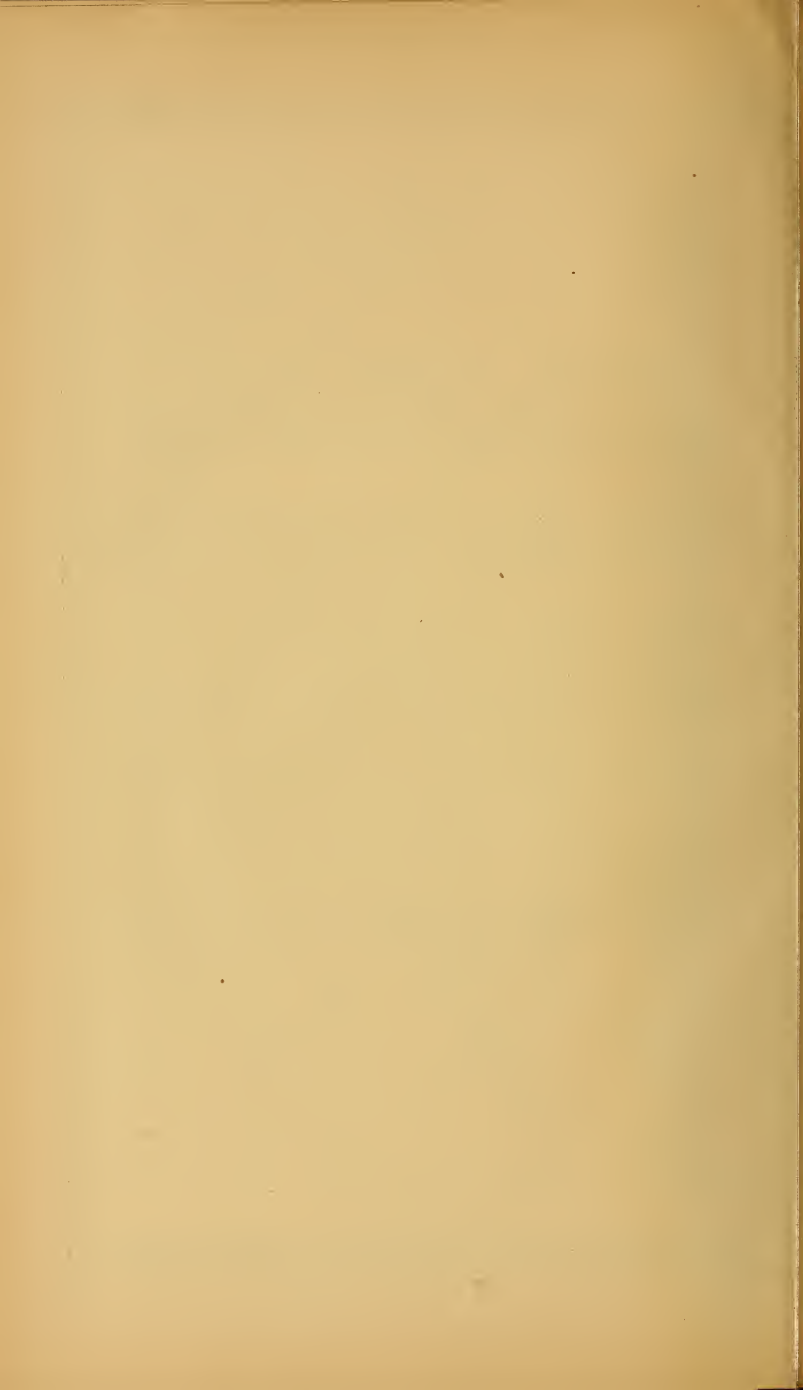



Plate 13

*Exhibits the ground plan and elevation of an acute angled platform staircase;
the wreath in two pieces.*

To find the major axis of the elliptical curve required for the centre of the mould. At Fig. 1, draw B S parallel to C R, equal to C D, Fig. 2; produce the curve A B to D; join A S and extend to D. Then R D equals half the length of the major axis, and A S determines the length of curve required for the mould.

For the face mould at Fig. 3, draw the major axis indefinitely. To find the points for the pins, to describe the centre curve, square up from C to D equal to C B, Fig. 1. From the point D, as centre, with R D, Fig. 1, as radius, describe arcs, cutting the major axis at 2 and 3, the points required. For the point to cut the curve, set up from the major axis equal to L J, Fig. 1; from the point, draw a line parallel to the major axis, cutting the curve at P; from the point P as centre, with A S, Fig. 1, as radius, describe an arc, cutting the curve at H; for the direction of the straight wood, draw P R, equal to D B, Fig. 2, and H R equal to S B, Fig. 2; for the width of the mould, and the points for the pins to describe the outside and inside curves, set off each way from D, half the width of the rail; from the points, draw lines parallel to D 2 and D 3, to intersect the major axis. The bevel for the centre joint is shown at C; for the straight wood, at S.

Fig. 3.

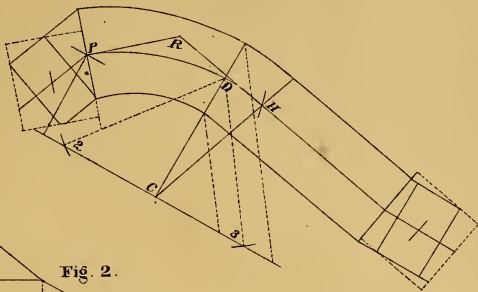
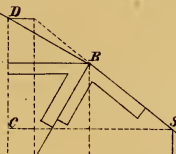

Fig. 2.

Pitch Board



Pitch Board

Steering

Landing

Fig. 1.

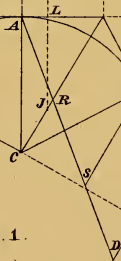

Scale 1 1/2 inches = 1 foot.



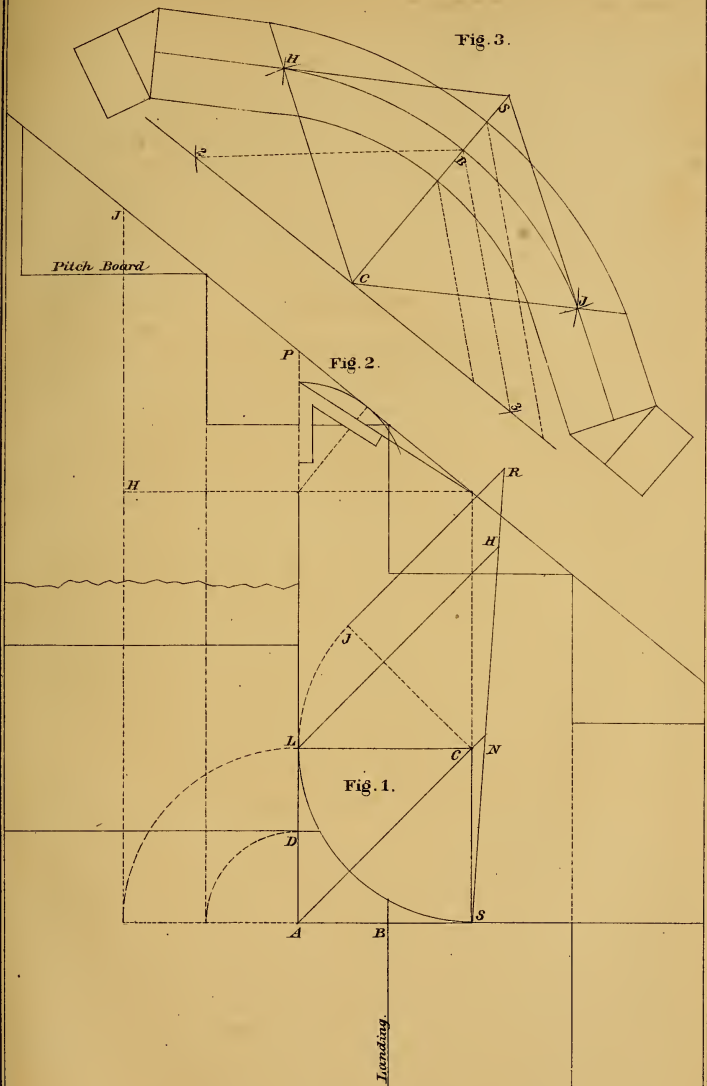

Plate 14

Exhibits the ground plan and elevation for a quarter platform staircase, showing the position of the risers in the cylinder, to continue the same plane or inclination in the wreath.

At Fig. 1 set off, from A, to B and D, equal to half the width of the step. To find the major axis of the elliptic curve for the centre of the mould, draw lines from L and J, Fig. 1, parallel to C A; set up from L to H equal to H J, Fig. 2; draw S H and extend to R. Then R N equals half the length of the major axis.

For the mould at Fig. 3, draw the major axis indefinitely. To find the points for the pins to describe the centre curve, square up from C to B equal to C L, Fig. 1; from the point B as centre, with N R, Fig. 1, as radius, describe arcs, cutting the major axis at 2 and 3, the points required; for the length of curve, and the direction of the straight wood, set off from C to S, equal to C A, Fig. 1; from the points C and S as centres, with P J, Fig. 2, as radius, describe arcs, cutting the curve at H and J; join S H and S J, for the direction required. For the width of the mould, and the points for the pins, to describe the outside and inside curves, set off each way from B half the width of the rail; from the points draw lines parallel to B 2 and B 3, to intersect the major axis. One bevel answers for the joints.



Scale $1\frac{1}{2}$ inches = 1 foot.

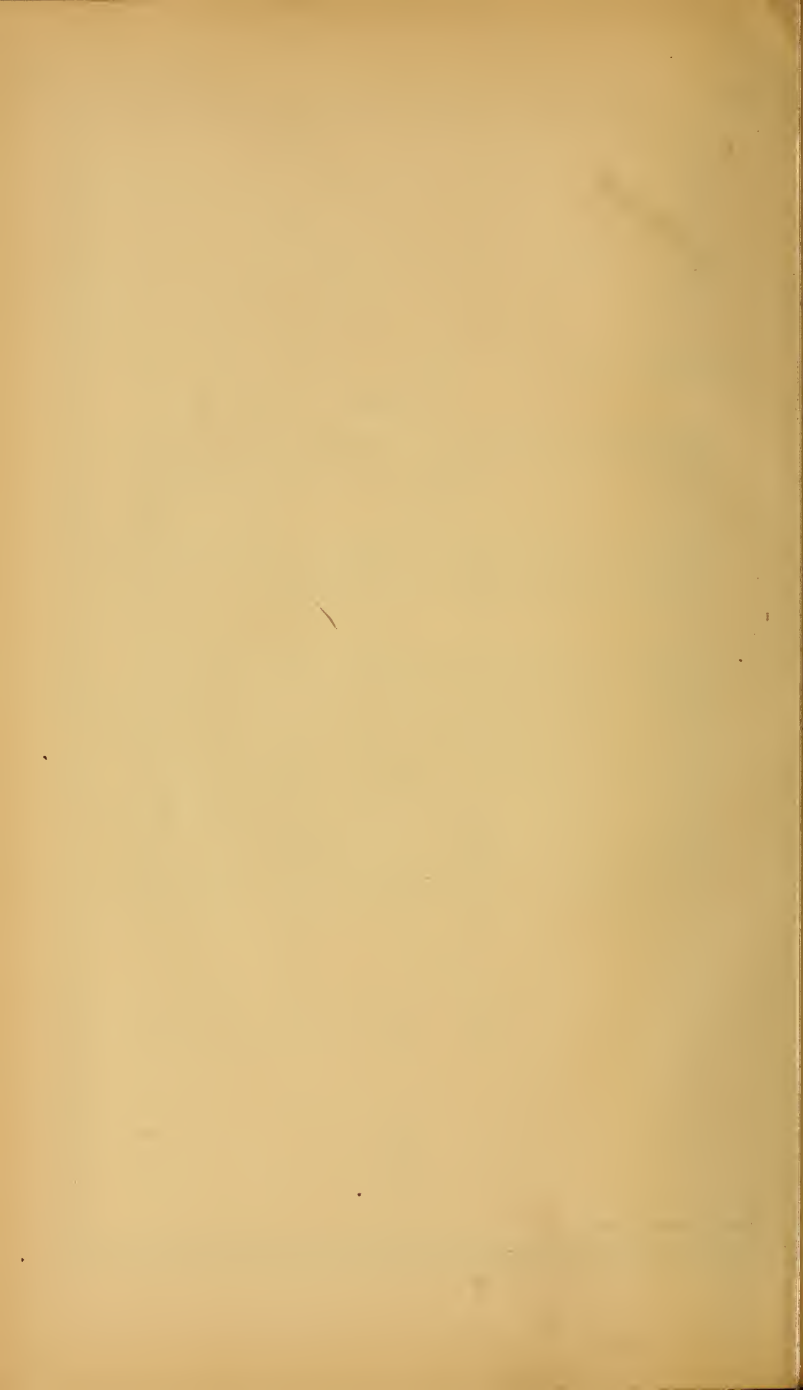



Plate 15

Exhibits the ground plan and elevation for the landing of the staircase, showing the method of finding the length of curve required for the mould, by which the workman is not obliged to make the joint in the centre, as the point of intersection of the level with the pitch line, determines the length of curve required.

For the length of the major axis of the elliptic curve for the centre of the mould, draw lines from A and S, Fig. 1, parallel to C L; set up from A to B, equal to A B, Fig. 2; join H B and extend to R. Then D R equals half the length of the major axis, and H B determines the length of the curve.

For the face mould at Fig. 3, draw the major axis indefinitely. To find the points for the pins to describe the centre curve, set up from C to D equal to C H, Fig. 1. From the point D as centre, with D R, Fig. 1, as radius, describe arcs, cutting the major axis at 2 and 3, the points required. For the direction of the straight wood and length of curve; from the point R as centre, with H B, Fig. 1, as radius, describe an arc, cutting the curve at S; draw R L equal to A L, Fig. 1, and S L equal to H B, Fig. 2. Then S L is the direction and S R the length of curve required. For the width of the mould and the points for the pins to describe the outside and inside curves: at Fig. 2, A J equals the width of the rail, and B J equals the width of the mould at R; set off each way from D half the width of the rail; from the points describe the curves. The bevel for the straight wood is shown at J; for the joint, at B.

Fig. 3.

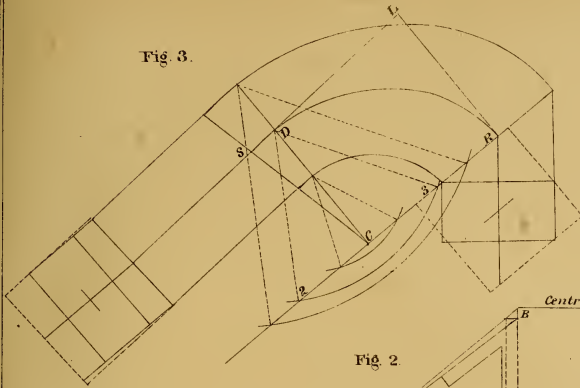
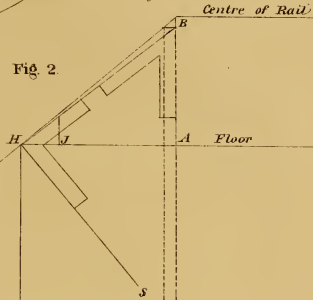
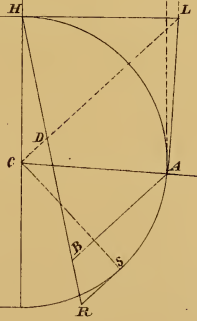

Fig. 2.



Pitch Board

Fig. 1.



Scale 2 1/4 inch = 1 foot.





Plate 16

Exhibits the ground plan and elevation for a staircase, with winders in the quarter circle; the wreath in one piece.

For the length of the major axis, of the elliptic curve for the centre of the mould: At Fig. 1, from the points A and D, draw lines parallel to C L; set up from A to H equal to R T, Fig. 2; join B H and extend to S. Then L S equals half the length of the major axis, and B H determines the length of curve required for the mould.

To form the mould at Fig. 3, draw the major axis indefinitely. To find the points for the pins to describe the centre curve, set up from C to B equal to C B, Fig. 1. From the point B as centre, with L S, Fig. 1, as radius, describe arcs, cutting the major axis at 2 and 3, the points required. For the point to cut the curve, set up from the major axis, equal to S T, Fig. 2; from the point draw a line parallel to the major axis, cutting the curve at S. From the point S as centre, with B H, Fig. 1, as radius, describe an arc, cutting the curve at J. For the direction of the straight wood, draw J H, equal to N H, Fig. 2, and S H, equal to T H, Fig. 2. For the width of the mould, and the points for the pins to describe the outside and inside curves, set off each way from B half the width of the rail; from the points draw lines parallel to B 2 and B 3, to intersect the major axis. The bevel for the joint J, is shown at S; for the straight wood, at H.

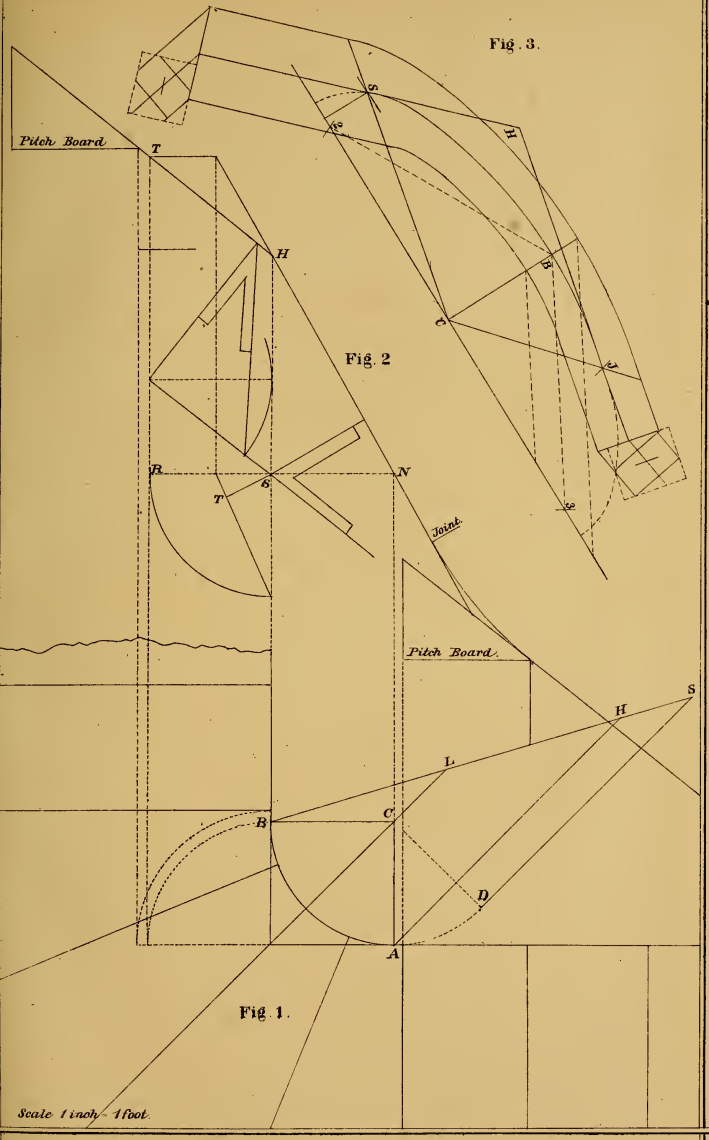

Fig. 3.

Fig. 2

Fig. 1.

Scale 1 inch = 1 foot.





Plate 17

Exhibits the ground plan and elevation of the landing, of an obtuse angled staircase, showing the method of determining the radius of the circle for the cylinder.

From the edge of the drawing-board, square up the line A D. At right angles to A B, draw the floor line and centre of rail. Place the pitch-board at D, and draw the pitch, to intersect the centre of rail at H; draw H B parallel to D A; then A B is the length of the tangents; draw B S, the direction required, to form the obtuse angle; make B S equal to B A; draw S C at right angles to S B; then C is the centre, and C A the radius of the arc, required for the cylinder.

To find the length of the major axis, of the elliptic curve for the centre of the mould, draw A P, Fig. 1, parallel to C B, equal to C H, Fig. 2; join S P, and extend to R. Then R H equals half the length of the major axis, and S P, determines the length of the curve, required for the mould.

To form the mould, at Fig. 3, draw the major axis indefinitely. To find the points, for the pins to describe the centre curve, square up from C to S, equal to C A, Fig. 1; set off, from C to P, equal to R H, Fig. 1. From the point S, as centre, with C P, as radius, describe arcs, cutting the major axis at 2 and 3, the points required. For the length of curve and direction of the straight wood, from the point P, as centre, with S P, Fig. 1, as radius, describe an arc, cutting the curve at J; draw P H, equal to S B, Fig. 1, and J H, equal to D H, Fig. 2. For the width of the mould, and the points for the pins, to describe the outside and inside curves, set off each way from S, half the width of the rail; at Fig. 2, set off from 3 to 2, equal to the width of the rail; then 7 6 equals the width of the mould, at P. The points, for the pins, are found in the same manner as those for the centre curve. The bevel, for the straight wood, is shown at 6; for the joint, at C.

Fig. 3.

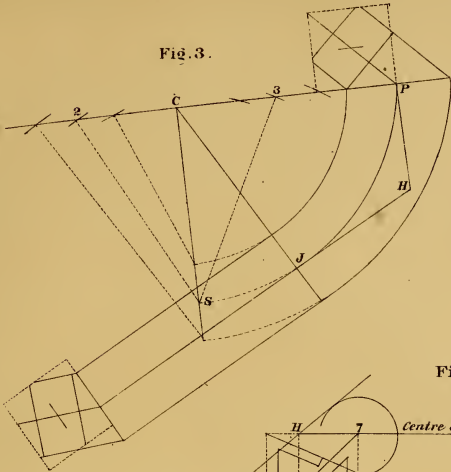

Fig. 2.

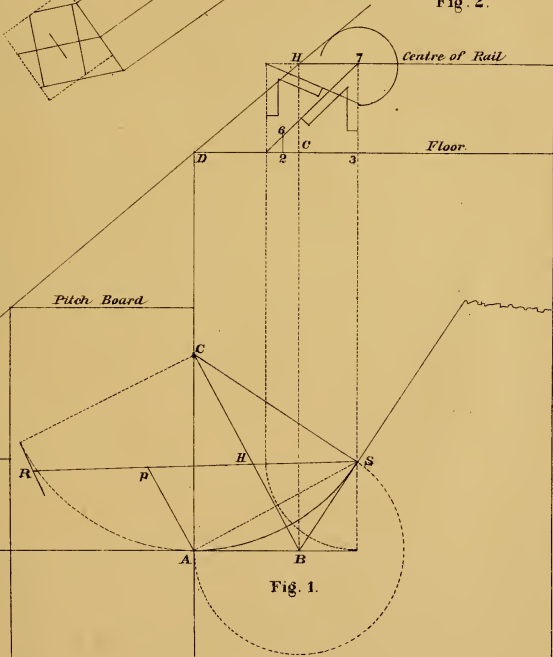

Fig. 1.

Scale $1\frac{1}{2}$ inches - 1 foot





Plate 18

Exhibits the plan and elevation for a platform staircase. For want of room, at the termination of the return flight, we have placed the riser at the starting, beyond the cylinder.

The length of the major axis, of the elliptic curve, for the centre of the mould, is found at Fig. 1, by drawing lines from B and E, parallel to C S, indefinitely; set up, from B to F, equal to R P, Fig. 2; join H F, and extend to G. Then J G equals half the length of the major axis, and H F determines the length of the curve, required for the mould.

For the face mould, at Fig. 3, draw the major axis indefinitely; square up from C to P, equal to C B, Fig. 1. To find the points for the pins, to describe the centre curve, take J G, Fig. 1, as radius, from the point P, as centre, describe arcs, cutting the major axis at 2 and 3, the points required. To find the point of contact and length of curve, at any point, set up from the major axis, equal to 2 3, Fig. 2; from the point, draw a line parallel to the major axis, cutting the curve at J. From the point J, as centre, with H F, Fig. 1, as radius, describe an arc, cutting the curve at S. For the direction of the straight wood, draw J R, equal to P N, Fig. 2, and S R, equal to L N, Fig. 2. For the width of the mould, set off each way from P, half the width of the rail. The points, for the pins, to describe the outside and inside curves, are shown at the intersection of the dotted lines, with the major axis. The joints are cut at right angles to the tangents. The bevel for the straight wood is shown at N; for the centre joint, at R.

Fig. 3

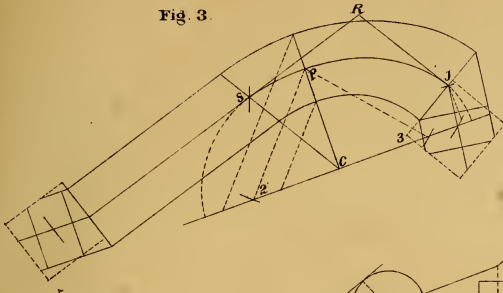
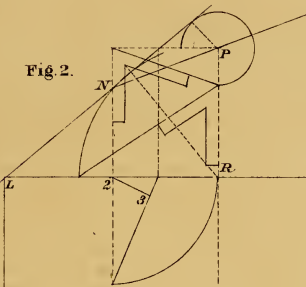

Fig. 2



Pitch Board

Pitch Board

Starting

Landing

Fig. 1

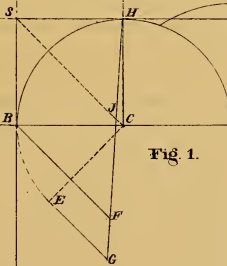

Scale 1 1/2 inches = 1 foot.

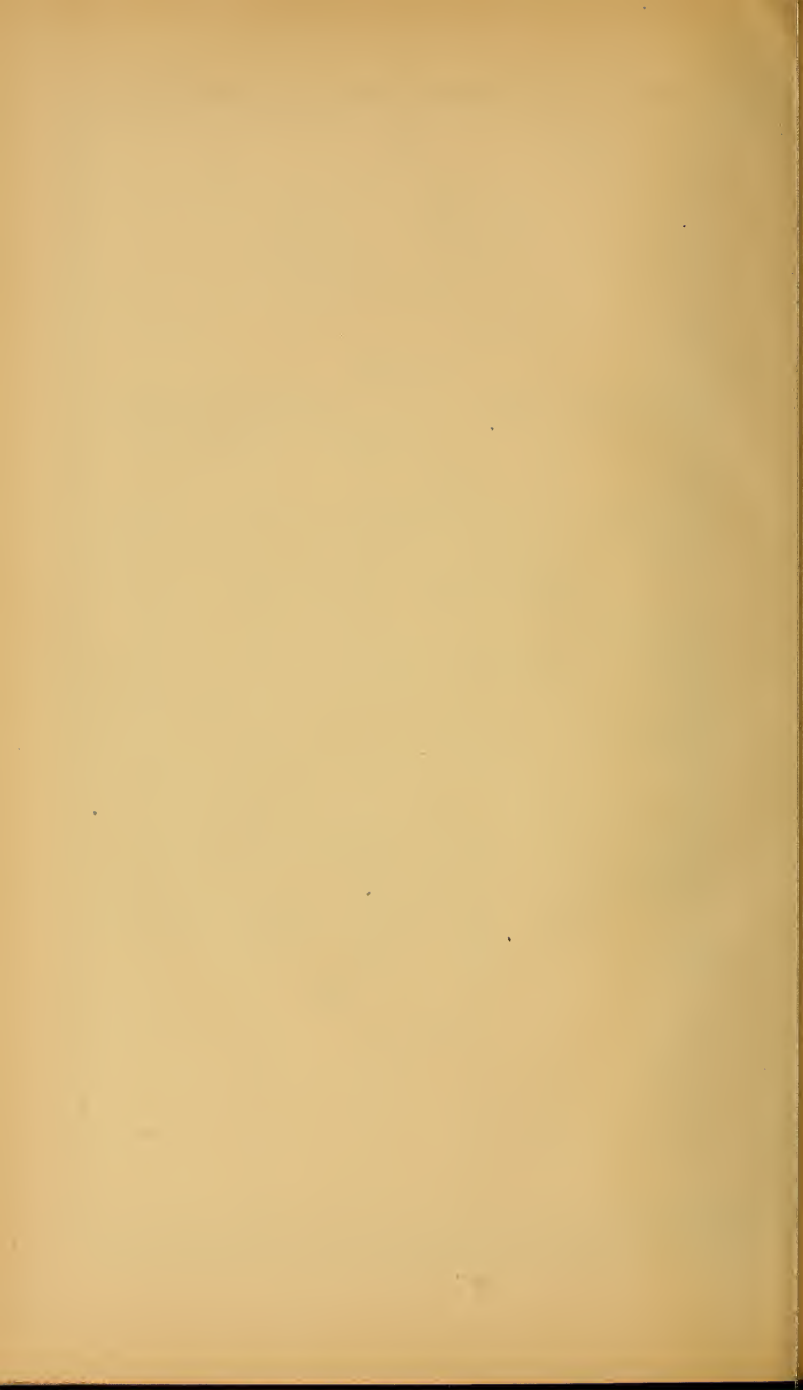



Plate 19

Exhibits the ground plan and elevation for the landing of a staircase; the riser placed on a line with the face of cylinder; the wreath in two pieces.

The length of the major axis, of the elliptic curve, for the centre of the mould, is found by drawing lines from A and P, Fig. 1, parallel to D L; set up, from A to B, equal to A C, Fig. 2; draw R B, and extend to C. Then J C equals half the length of the major axis, and R B determines the length of curve, required for the mould.

To form the mould, at Fig. 3, draw the major axis indefinitely. To find the points for the pins, to describe the centre curve, square up from the point C to B, equal to D A, Fig. 1. To find the points, for the pins, to describe the centre curve; from the point B, as centre, with J C, Fig. 1, as radius, describe arcs, cutting the major axis at 2 and 3, the points required. For the points, to cut the curve, set up from the major axis, equal to 2 3, Fig. 2; from the point, draw a line parallel to the major axis, cutting the curve at J. From the point J, as centre, with R B, Fig. 1, as radius, describe an arc, cutting the curve at L; then L is the point of contact, and L J the length of curve. For the direction of the straight wood, draw J H, equal to C D, Fig. 2, and L H, equal to E D, Fig. 2. For the width of the mould, and the points for the pins to describe the outside and inside curves, set off each way from B, half the width of the rail. From the points, draw the dotted lines parallel to B 2 and B 3, intersecting the major axis, at the points required. The bevel, for the centre joint, is shown at A; for the straight wood, at D, Fig. 2.

The mould, for the upper wreath, is shown at Fig. 4; draw A B, equal to A D, Fig. 1. At right angles to A B, draw A C, equal to C F, Fig. 2; set off, each way from B, half the width of the rail; join B C. For the width of the straight wood; from the points set off from B, draw the dotted lines parallel to B C, to intersect the line A C. The curves are drawn with the compasses. The bevel required, is shown at F.





Plate 20

Exhibits the continuation of the staircase, shown on Plate 19, to the starting of the second flight.

To find the length of the major axis, of the elliptic curve required for the centre of the mould, at Fig. 1, draw lines from the points A and P, parallel to S R; from the point A, set up to B, equal to L B, Fig. 2; draw C B, and extend to D. Then J D equals half the length of the major axis, and C B determines the length of curve required for the mould.

To form the mould, at Fig. 3, draw a line for the major axis. To find the points, for the pins to describe the centre curve, square up from C to S, equal to S A, Fig. 1. From the point S, as centre, with J D, Fig. 1, as radius, describe arcs, cutting the major axis, at 2 and 3, the points required. To find the points, to cut the curve, set up from the major axis, equal to 2 3, Fig. 2; from the point, draw a line parallel to the major axis, cutting the curve at D. From the point D, as centre, with C B, Fig. 1, as radius, describe an arc, cutting the curve at P. For the direction of the straight wood, draw D H, equal to S C, Fig. 2, and P H, equal to B C, Fig. 2. For the width of the mould, and the points for the pins to describe the outside and inside curves, set off each way from S, half the width of the rail; from the points, draw lines parallel to S 2 and S 3, cutting the major axis at the points required. The bevel, for the straight wood, is shown at S; for the centre joint, at B.

The mould, for the lower wreath, is shown at Fig. 4. Draw B C, equal to S C, Fig. 1, and B A, equal to S H, Fig. 2; set off each way from C, half the width of the rail. The width of the straight wood, is found by drawing the dotted lines parallel to A C. The curves are drawn with the compasses. The bevel, for the straight wood, is shown on the line H S.

Fig. 4.

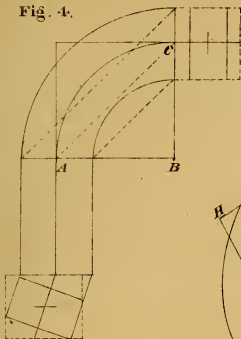

Fig. 3.

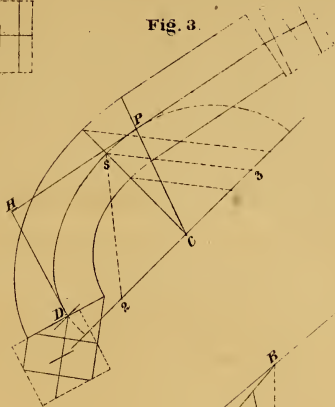
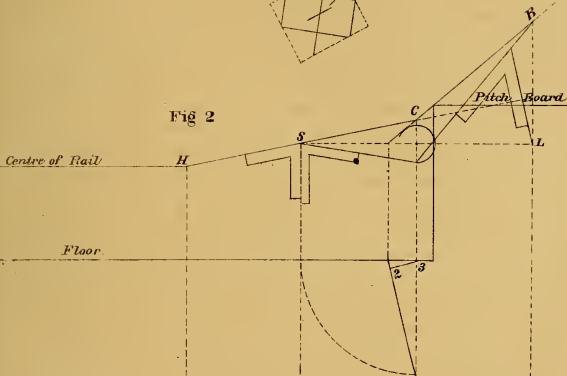

Fig 2



Centre of Rail

Floor

Pitch Board

Fig 1.

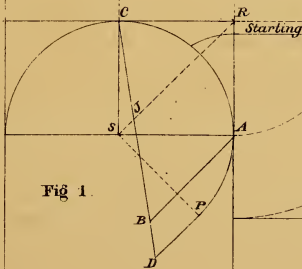

Starting

Scale 1 1/2 inches = 1 foot.





Plate 21

Exhibits the ground plan and elevation for a quarter circle of winders, and the starting of the return flight, from the spring of the cylinder; the wreath in two pieces.

To find the major axis, of the elliptic curve for the centre of the moulds, draw lines from A and L, Fig. 1, parallel to C P, indefinitely; set up from A to B, equal to L S, Fig. 2, and from A to D, equal to R H, Fig. 2; draw S B, and S D, and extend to J and R; produce P C to H. Then H J equals half the length of the major axis, of the elliptic curve for the centre of the mould, at Fig. 3, and N R equals half the length of the major axis, for the mould, at Fig. 4, and S D determines its length.

For the face mould, at Fig. 3, draw the major axis; square up from C to B, equal to C S, Fig. 1. The points for the pins, to describe the centre curve, are found by taking H J, Fig. 1, as radius, from the point B as centre, and describing arcs, cutting the major axis at 2 and 3, the points required. For the direction of the straight wood, and length of curve, make C H equal to C P, Fig. 1. From the points C and H, as centres, with B S, Fig. 2, as radius, describe arcs, cutting the curve, at S and J; draw H J, and H S, indefinitely. Then J S is the length of curve, and H S the direction of the straight wood. For the width of the mould, set off each way from B, half the width of the rail. The points for the pins, to describe the outside and inside curves, are at the intersection of the dotted lines, with the major axis. The bevel, for the joints, is shown at B.

For the face mould, at Fig. 4, draw the major axis; square up from A to B, equal to C A, Fig. 1. The points for the pins, to describe the centre curve, are found by taking N R, Fig. 2, as radius, from the point B as centre, describe arcs, cutting the major axis at 2 and 3, the points required. To find the point of contact, and length of curve, set up from the major axis, equal to 3 2, Fig. 2; from the point, draw a line parallel to the major axis, cutting the curve at H. From the point H, as centre, with S D, Fig. 2, as radius, describe an arc, cutting the curve at J. Then H is the point of contact of the straight wood, with the curve, and H J the length of curve required. The direction of the straight wood, is found by drawing J S, equal to S G, Fig. 2, and H S, equal to H G, Fig. 2. For the width of the mould, set off each way from B, half the width of the rail. The points for the pins, to describe the outside and inside curves, are at the intersection of the dotted lines, with the major axis. The joints are cut at right angles to the tangents. The bevel, for the straight wood, is shown at G; for the centre joint, at S.

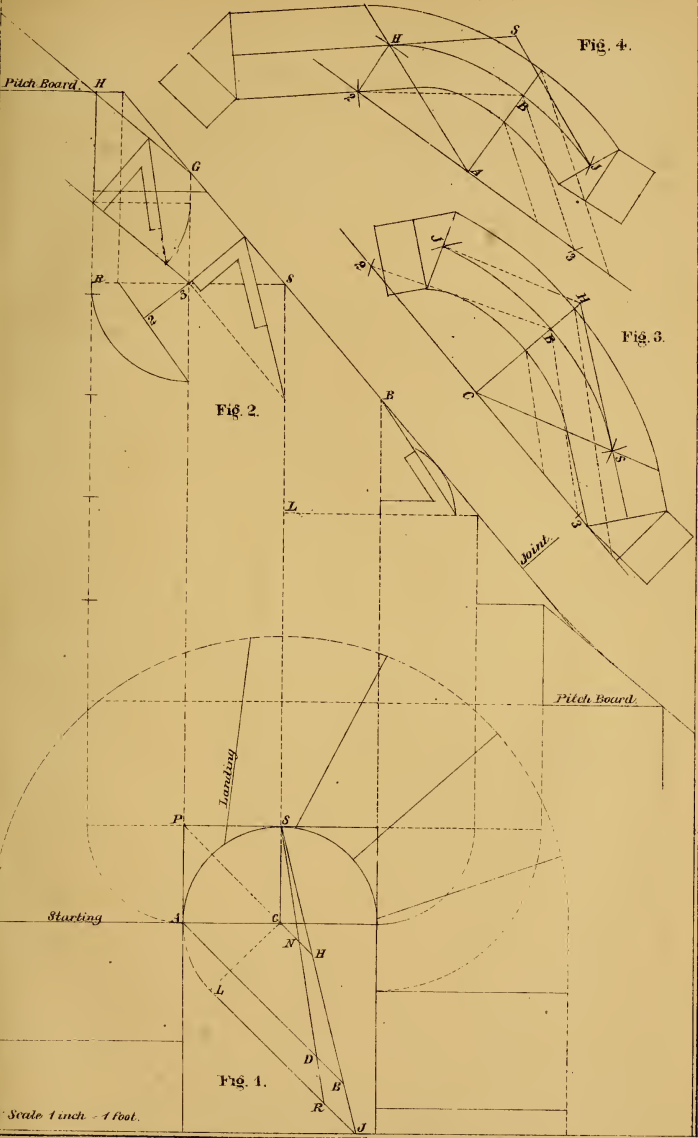

Fig. 2.

Fig. 4.

Fig. 3.

Fig. 1.

Scale 1 inch = 1 foot.

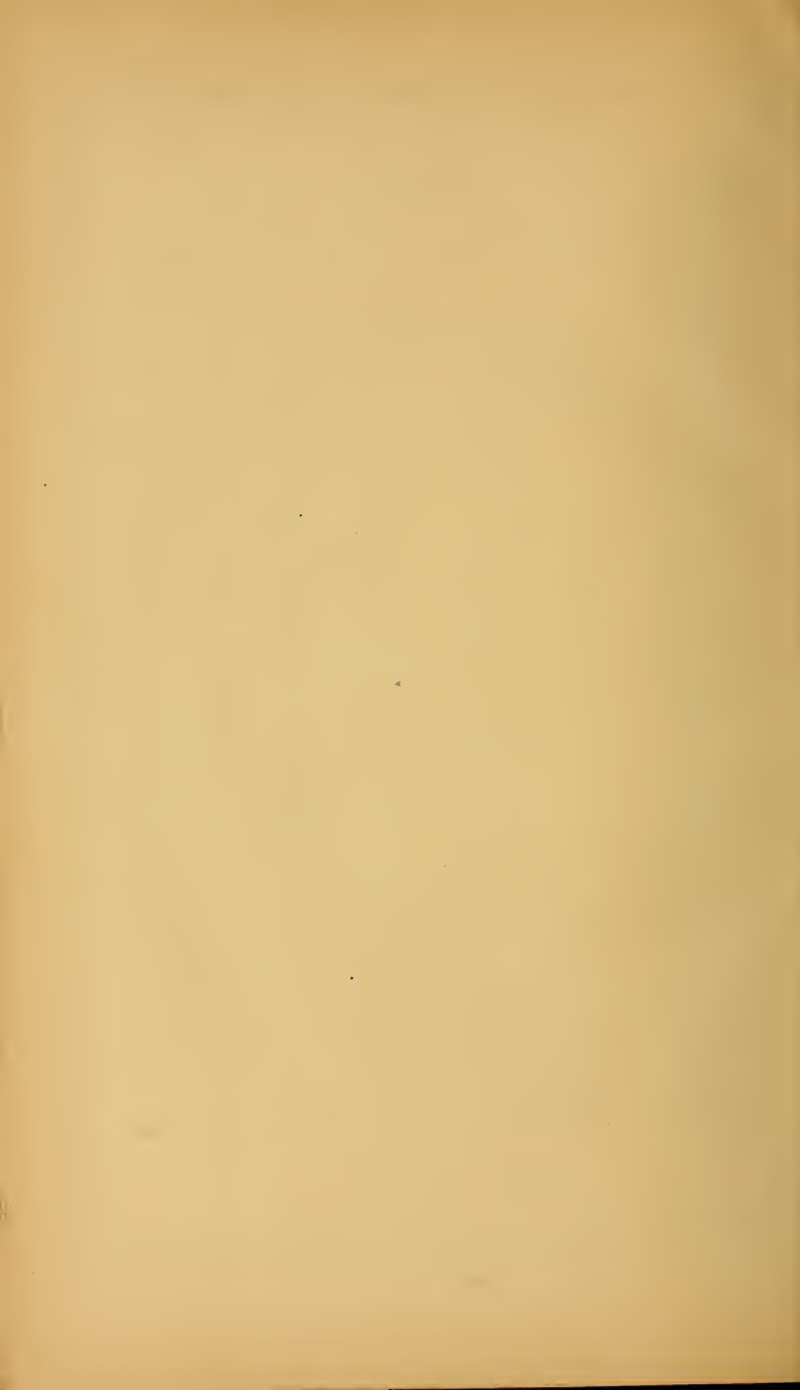

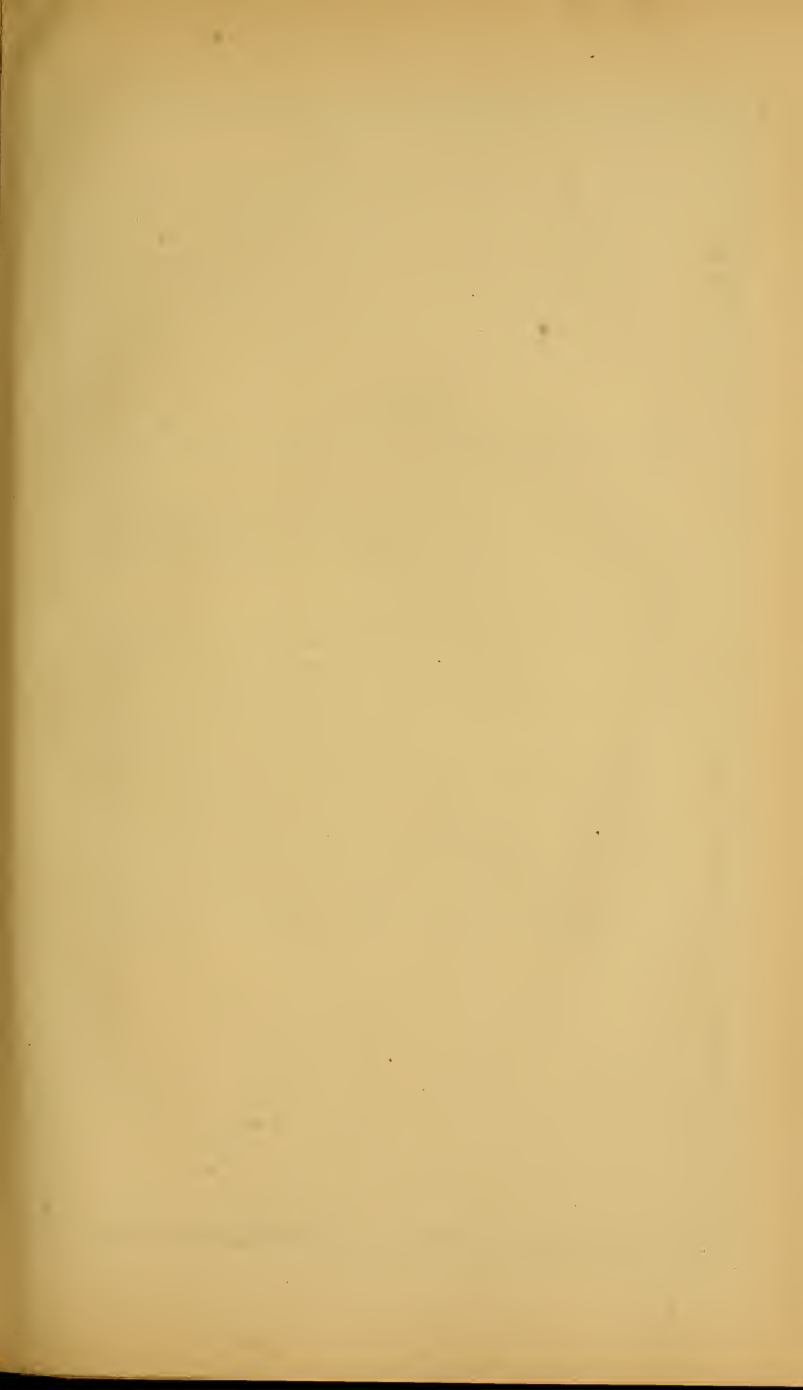

Plate 22

Exhibits the ground plan and elevation, for a semi-circle of winders, at the termination of the staircase; the wreath in two pieces.

To find the length of the major axis, of the elliptic curve, required for the centre of the mould: At Fig. 1, draw lines from A and E parallel to L C; set up from A to B, equal to B S, Fig. 2; draw D B, and extend to R. Produce L C to H, then H R equals half of the major axis of the elliptical curve, for the centre of the mould.

To draw the face mould, at Fig. 3, draw the major axis indefinitely. To find the points for the pins, to describe the centre curve, square up from C to D equal to C D, Fig. 1; from the point D as centre, with H R, Fig. 1, as radius, describe arcs, cutting the major axis at 2 and 3, the points required. From the point C as centre, with T R, Fig. 2, as radius; describe arcs, cutting the curve at S and J; join C S and C J. For the direction of the straight wood, draw S B and J B, parallel to C J and C S. To find the points for the pins, to describe the outside and inside curves, set off each way from D, half the width of the rail; from the points, draw the dotted lines parallel to D 2 and D 3, intersecting the major axis at the points required. One mould answers for both wreaths; by removing the straight wood at J, leaves the mould for the lower wreath; the same being done at S, leaves the mould for the upper wreath. One bevel answers for all the joints.

Fig. 3.

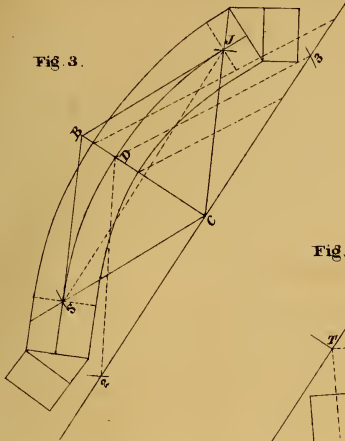

Fig. 2.

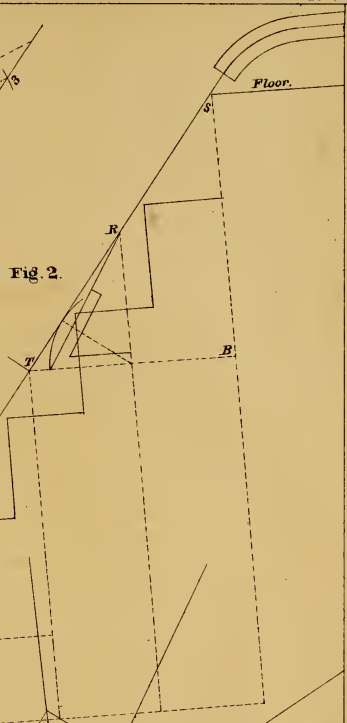
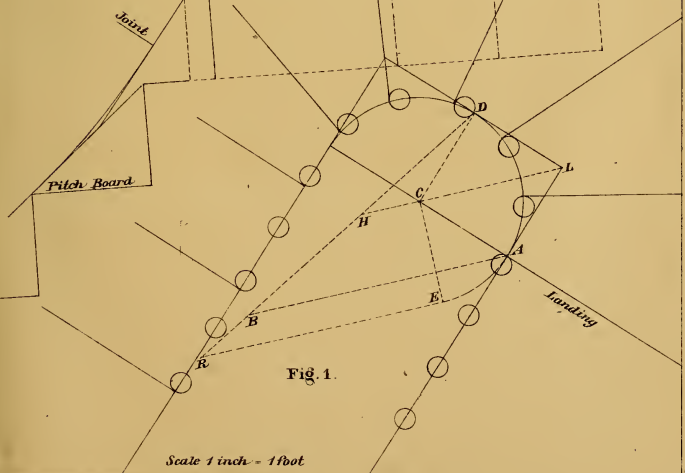

Fig. 1.



Scale 1 inch = 1 foot





Plate 23

Exhibits the ground plan and elevation of a quarter platform staircase. The platform placed one step below the floor, to continue the same width of passage at the landing; the wreath in two pieces.

For the length of the major axis, of the elliptic curve, for the centre of the mould, draw lines from A and J, Fig. 1, parallel to C N; set up from A to L, equal to P L, Fig. 2; draw S L, and extend to H. Produce N C to R, then R H equals half the length of the major axis, and S L determines the length of the curve, required for the face mould, shown at Fig. 3.

To form the face mould, at Fig. 3, draw the major axis indefinitely; square up from C to S, equal to C A, Fig. 1. The points for the pins, to describe the centre curve, are found by taking R H, Fig. 1, as radius, with the point S as centre, describe arcs, cutting the major axis at 2 and 3, the points required. The point of contact, is found by setting up from the major axis, equal to 2 3, Fig. 2; from the point, draw a line parallel to the major axis, cutting the curve at H, the point required. From the point H as centre, with S L, Fig. 1, as radius, describe an arc, cutting the curve at P. For the direction of the straight wood, draw P R equal to L B, Fig. 2, and H R, equal to C B, Fig. 2. For the width of the mould, set off each way from S half the width of the rail. The points for the pins, to describe the outside and inside curves, are shown at the intersection of the dotted lines with the major axis. The bevel shown at C, is for the straight wood; for the joint P, at B.

The mould for the wreath that connects with the level rail, is shown at Fig. 4; draw the major axis, D B, equal to L D, Fig. 2; square up from D to C, equal to C A, Fig. 1; set off each way from C half the width of the rail; from the points draw the dotted lines parallel to C B, for the width of the straight wood at B. The points for the pins, to describe the curves, are found by drawing the dotted curves to intersect the major axis. The bevel for the straight wood is shown at D, Fig. 2.

Fig. 3.

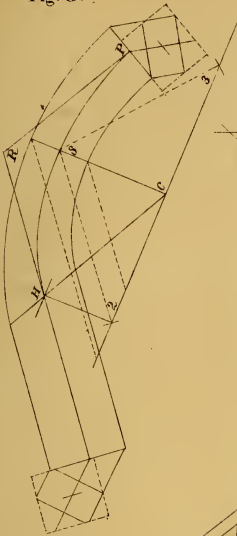

Fig. 4.

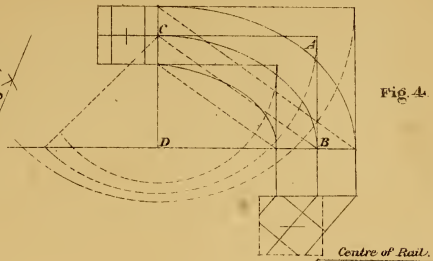

Fig. 2.

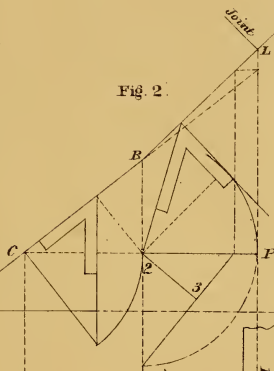
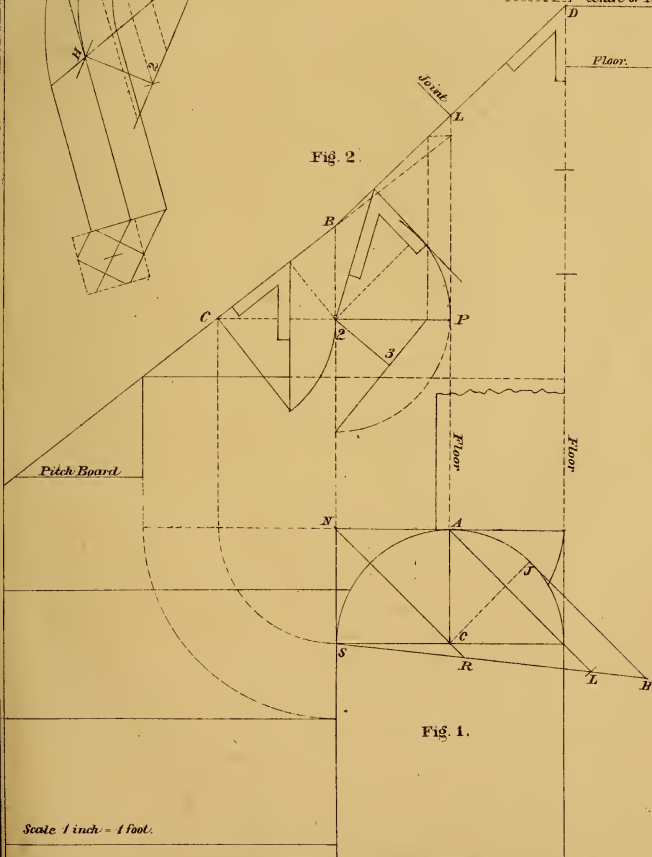

Fig. 1.



Scale 1 inch = 1 foot.

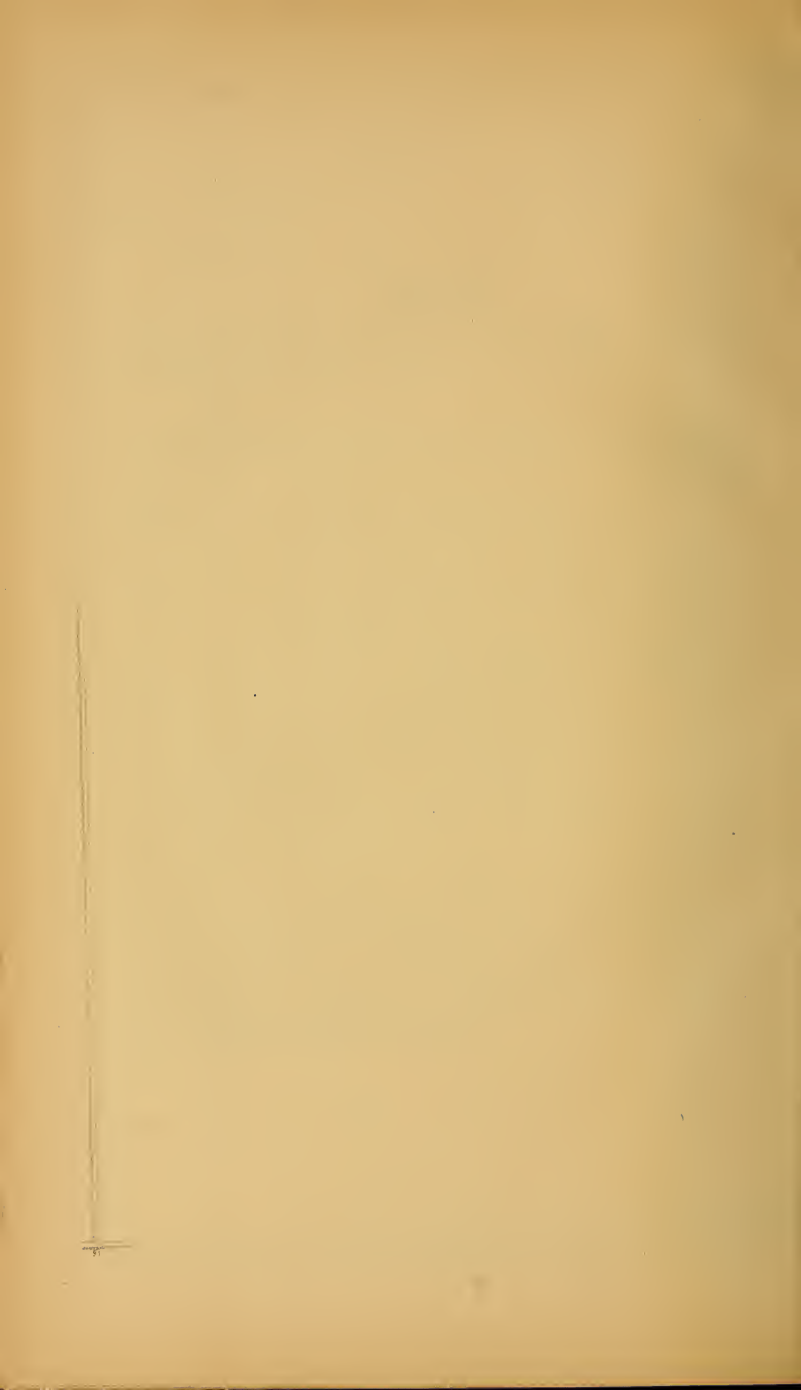



Plate 24

Exhibits the ground plan and elevation, for a staircase, with a quarter circle of winders at the landing.

To find the major axis, of the elliptic curve for the centre of the mould, draw lines from the points, J and L, Fig. 1, parallel to B C, indefinitely; set up from J to P, equal to R S, Fig. 2; draw A P, and extend to D; produce B C to H; then H D equals half the length of the major axis, and A P determines the length of the curves, required for the mould.

For the mould at Fig. 3, draw the major axis indefinitely. To find the points for the pins, to describe the centre curve, square up from C to S equal to C A, Fig. 1; from the point S as centre, with H D, Fig. 1, as radius, describe arcs, cutting the major axis, at 2 and 3, the points required. To find the points to cut the curve, set up from the major axis, equal to 2 3, Fig. 2; from the point, draw a line parallel to the major axis, cutting the curve at P; from the point P as centre, with A P, Fig. 1, as radius, describe an arc, cutting the curve at H. For the direction of the straight wood, draw H R, equal to S B, Fig. 2, and P R equal C B, Fig. 2. The points for the pins to describe the outside and inside curves are found, by setting off each way from S half the width of the rail; from the points, draw lines parallel to S 2 and S 3, to intersect the major axis; the joints are cut at right angles to the tangents. The bevel for the centre joint at H, is shown at B, for the straight wood, at R.

The mould for the wreath at the landing, is shown at Fig. 4; draw the major axis indefinitely, square up from B to H, equal to C J, Fig. 1; set off from B to S, equal to S T, Fig. 2; for the width of the mould at S, set off each way from H half the width of the rail; from the points draw lines parallel to H S. The points for the pins to describe the curves, are found by describing the dotted curves to intersect the major axis. The bevel required for the straight wood is shown at T.

Fig. 3

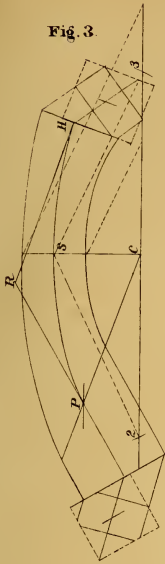

Fig. 4

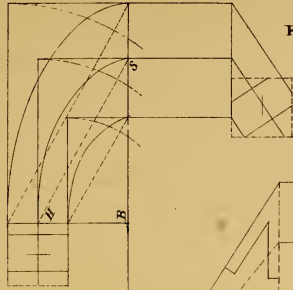
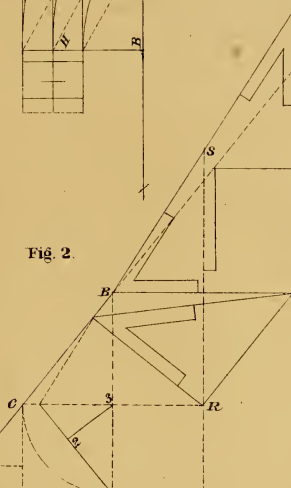

Fig. 2



Pitch Board

Landing

Fig. 1

Scale 1 inch = 1 foot.

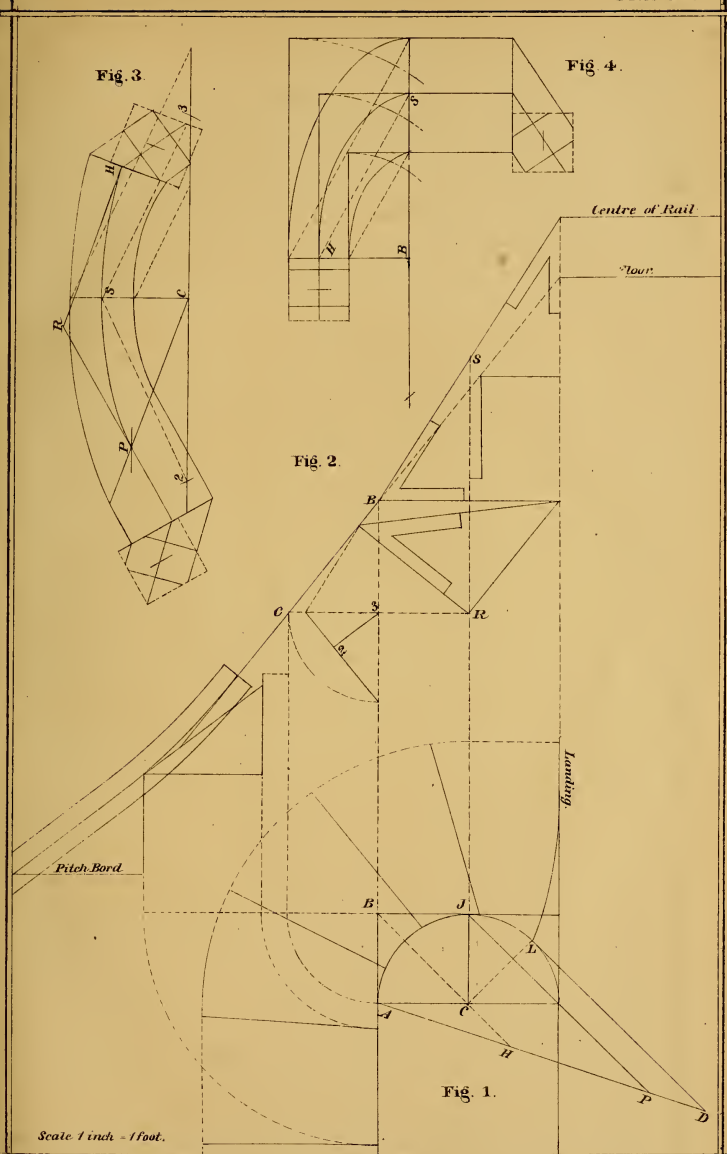





Plate 25

Exhibits the plan and elevation of a staircase, starting with a quarter circle of winders.

To find the major axis of the elliptic curve for the centre of the mould, draw lines from H and L, Fig. 1, parallel to R C indefinitely. Set up from H to S, equal to P J, Fig. 2; draw A S, and extend to D; produce R C to P; then P D equals half the length of the major axis, and A S determines the length of the curve required for the mould.

To draw the face mould at Fig. 3, draw lines at right angles to each other. To find the points for the pins, to describe the centre curve, set up from C, to B, equal to C H, Fig. 1. From the point B as centre, with P D, Fig. 1, as radius, describe arcs, cutting the major axis at 2 and 3, the points required. To find the point to cut the curve, set up from the major axis, equal to 2 3 Fig. 2; from the point draw a line parallel to the major axis, cutting the curve at S; from the point S, as centre, with A S, Fig. 1, as radius, describe an arc, cutting the curve at T. For the direction of the straight wood, draw T L equal to H S, Fig. 2, and S L equal to J S, Fig. 2. To find the points for the pins, to describe the outside and inside curves, set off each way from B half the width of the rail; from the points, draw lines parallel to B 2 and B 3, to intersect the major axis. The bevel for joint T, is shown at P, for the straight wood at S.

The mould for the wreath at the starting is shown at Fig. 4; draw the major axis indefinitely, square up from C to D, equal to C A, Fig. 1; set off from C to L, equal to H V, Fig. 2. For the width of the mould set off each way from D, half the width of the rail; from the points draw lines parallel to D L. The points for the pins, to describe the elliptic curves, are shown at the intersection of the dotted curves, with the major axis. The bevel is shown at H.

Fig. 3.

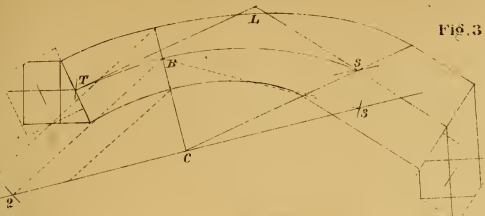

Fig. 4.

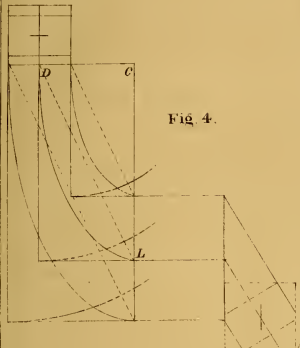
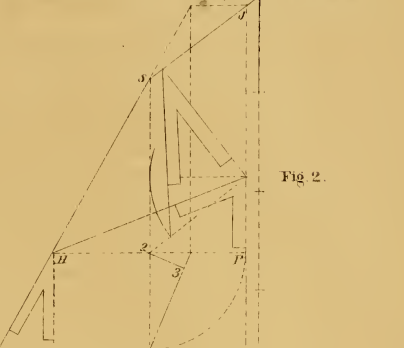

Fig. 2.



Centre of Rail.

Floor.

Starting

Fig. 1.

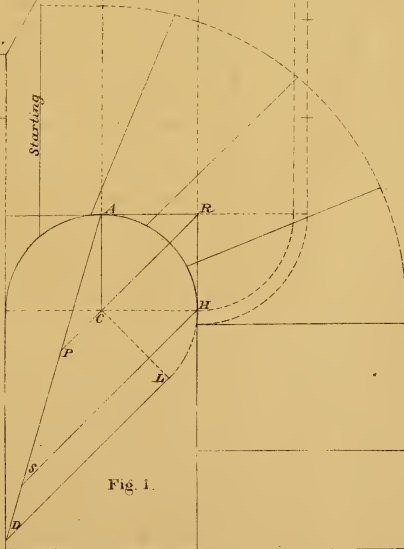

Scale 1 inch = 1 foot.





Plate 26

Exhibits the ground plan for a staircase starting with a scroll. At Fig. 1, draw the eye one inch wider than the rail; divide the radius of the eye into four equal parts; set one part off from the centre and form the square; through the centre of square draw a line parallel to 4 3; set off from C to D the width of the rail, and draw the curves that form the scroll.

To find the major axis of the elliptic curve for the centre of the mould; at Fig. 3, draw lines from H and N, Fig. 1, parallel to J 5, indefinitely; set up from H to E, equal to B C, Fig. 2, draw R E and extend to F; then J F equals half the length of the major axis, and R E determines the length of curve, required for the mould.

At Fig. 3, draw the major axis indefinitely. To find the points for the pins to describe the centre curve; square up from C to S equal to R 5, Fig. 1, from the point S as centre, with J F, Fig. 1, as radius, described arcs, cutting the major axis, at 2 and 3, the points required. To find the point to cut the curve, set up from the major axis equal to 2 3, Fig. 2; from the point draw a line parallel to the major axis, cutting the curve at N; from the point N as centre, with R E, Fig. 1, as radius, describe an arc, cutting the curve at H. For the direction of the straight wood, draw N B equal to L S, Fig 2, and H B equal to C S, Fig. 2. For the width of the mould, and the points for the pins to describe the outside and inside curves, set off each way from S, half the width of the rail, from the points, draw lines parallel to S 2, and S 3, to intersect the major axis. The bevel for the straight wood, is shown on the line 2 S, for the centre joint, on the line S C.

To draw the mould for the quadrant D R: At fig. 4, draw C B, equal to 4 R, Fig. 1, and C D equal to P L, Fig. 2. For the width of the mould, set off each way from B half the width of the rail, from the points, draw lines parallel to B D, to intersect the line C D. The curves are drawn with the compasses. The bevel is shown at L.

Fig. 3.

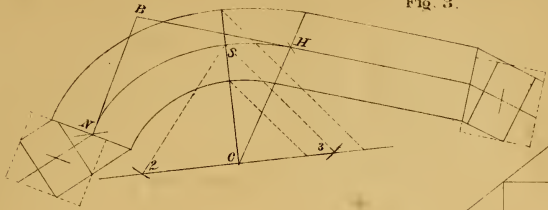

Fig. 4.

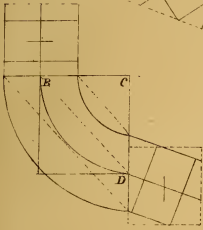

Fig. 2.

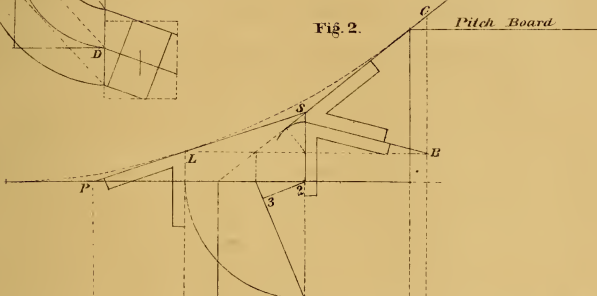
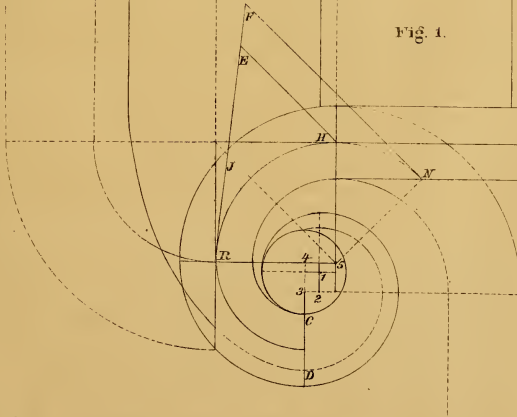

Fig. 1.



Scale inch - 1 foot.



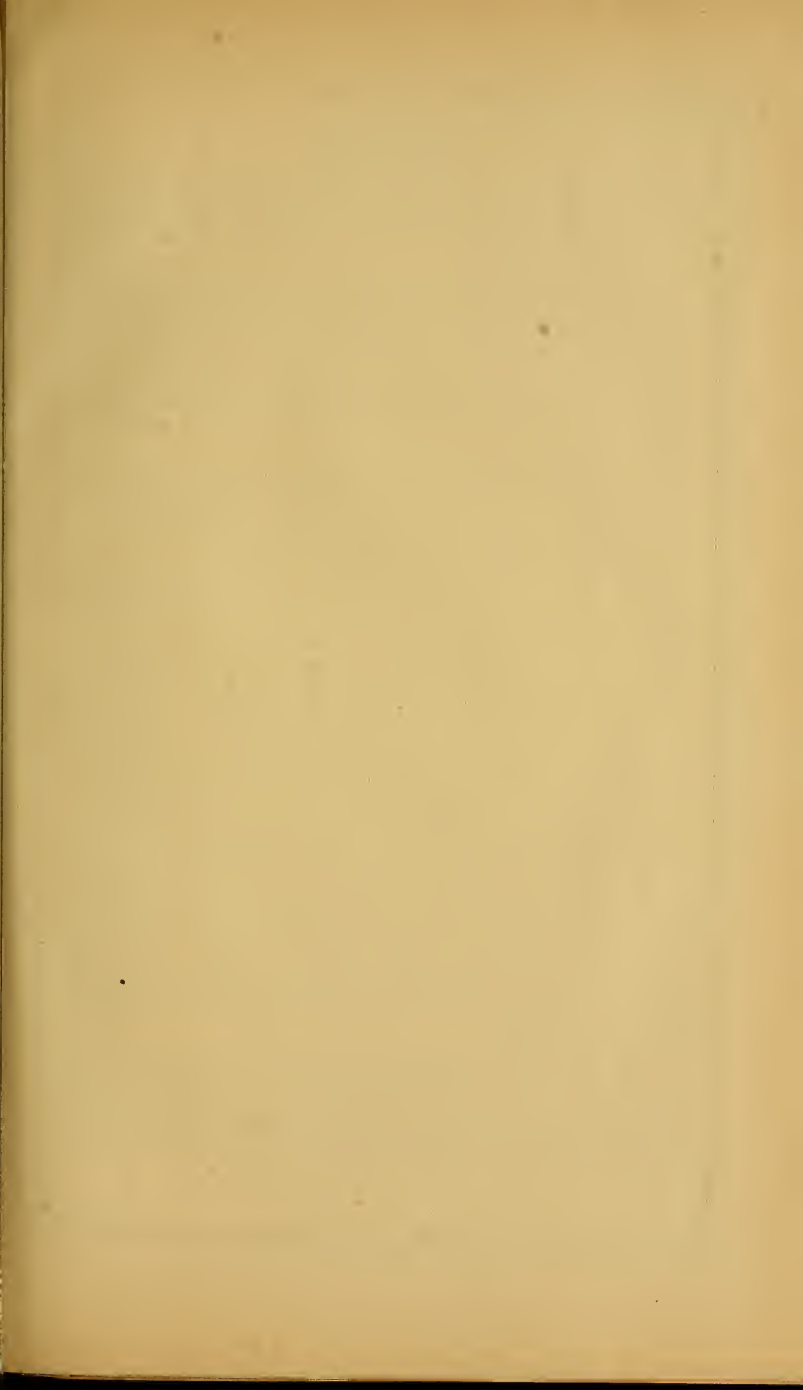

Plate 27

Exhibits the ground plan for the turnout, at the starting of the staircase. The curve drawn from centres of unequal radii. The wreath in one piece, forming its own easings at the newel.

At Fig. 1, draw the curves, and the newel cap, also the tangents. Produce the radius B D, indefinitely, draw L S Fig. 2, at right angles to B D; set up from L to N the height of three raises. Place the pitch board, and draw the common pitch. Set up from S to P the difference in the heights of the newel and shoit baluster. To find the positions of the steps, set up from L to H, the height of one riser, draw H J parallel to L S, cutting the pitch at the point required for the face of the riser, which determines the position of the steps on the plan.

For the length of the major axis of the elliptic curve for the centre of the mould, draw D P, Fig. 1, parallel to B C, equal to E N, Fig. 2; draw L P and extend to J; then H J equals half the length of the major axis, and L P determines the length of curve, required for the mould.

For the mould at Fig. 3, draw the major axis indefinitely. To find the points for the pins to describe the centre curve, square up from C to D equal to B D, Fig. 1. From the point D as centre, with H J, Fig. 1, as radius, describe arcs, cutting the major axis at 2 and 3, the points required. For the width of the mould and the points for the pins to describe the outside and inside curves, set off each way from D half the width of the rail. From the points, draw lines parallel to D 2 and D 3, to intersect the major axis. For the length of curve, and direction of the straight wood, set up from C to L equal to B C, Fig. 1; from the point L as centre, with R N, Fig. 2, as radius, describe arcs, cutting the curve at S and P, draw L S and L P indefinitely; set off from L to R equal to R P, Fig. 2, draw R H at right angles to L R equal to R S, Fig. 1; extend the tangent S L to T equal to L P, join T H, set off from S to A, equal to D G, Fig. 1, draw A H, indefinitely. From the point N as centre, describe the curve from H, tangent to the curve S D; through the point N, draw the dotted line at right angles to the tangent L R, on which find the centres to describe the outside and inside curves. The width of the mould is shown at Fig. 2; by setting off from 2 to 3, equal to the width of the rail, then the bevel determines the width of the mould at H. The bevel for the straight wood is shown at E, Fig. 2, for the joint at R.

At Fig. 4 is shown a practical method of finding the spring bevels for the joints; form a piece to fit the angle D N R, Fig. 1, draw B A at right angles to N B, and B C the pitch of the rail. Work to the lines and apply the bevels as shown, the bevel applied to the line B C is for the straight wood. The one shown as S is for the joint at the newel.

Fig. 3.

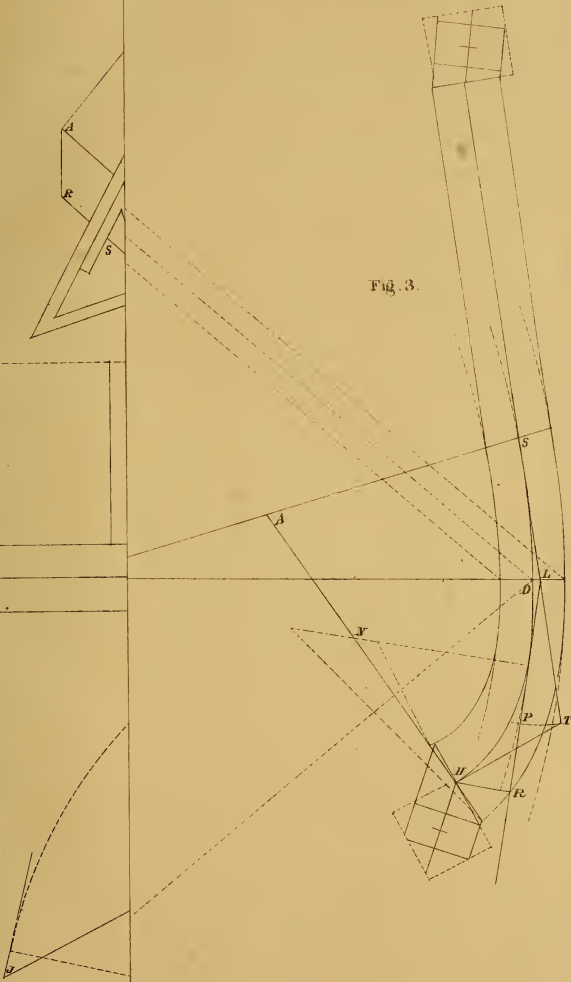

Scale 1 inch = 1

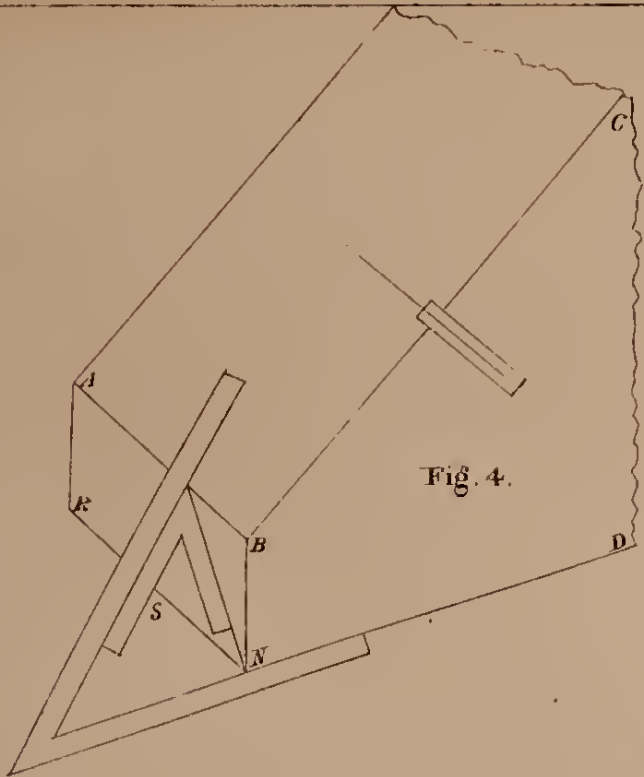

Fig. 4.

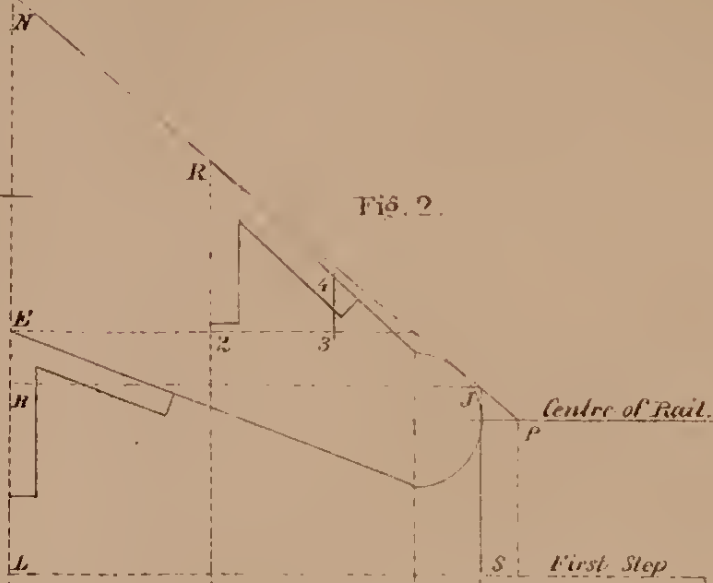

Fig. 2.

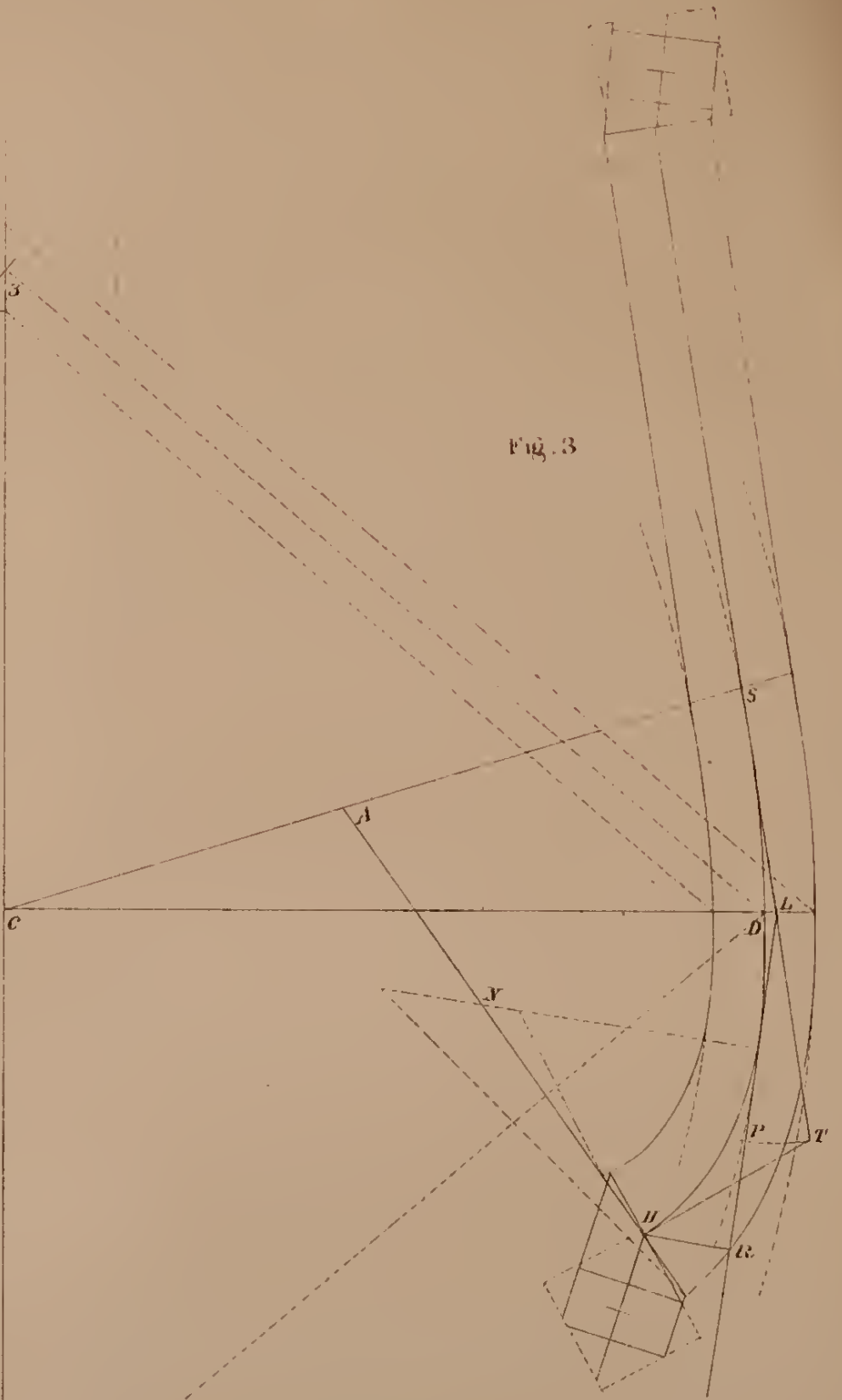

Fig. 3.

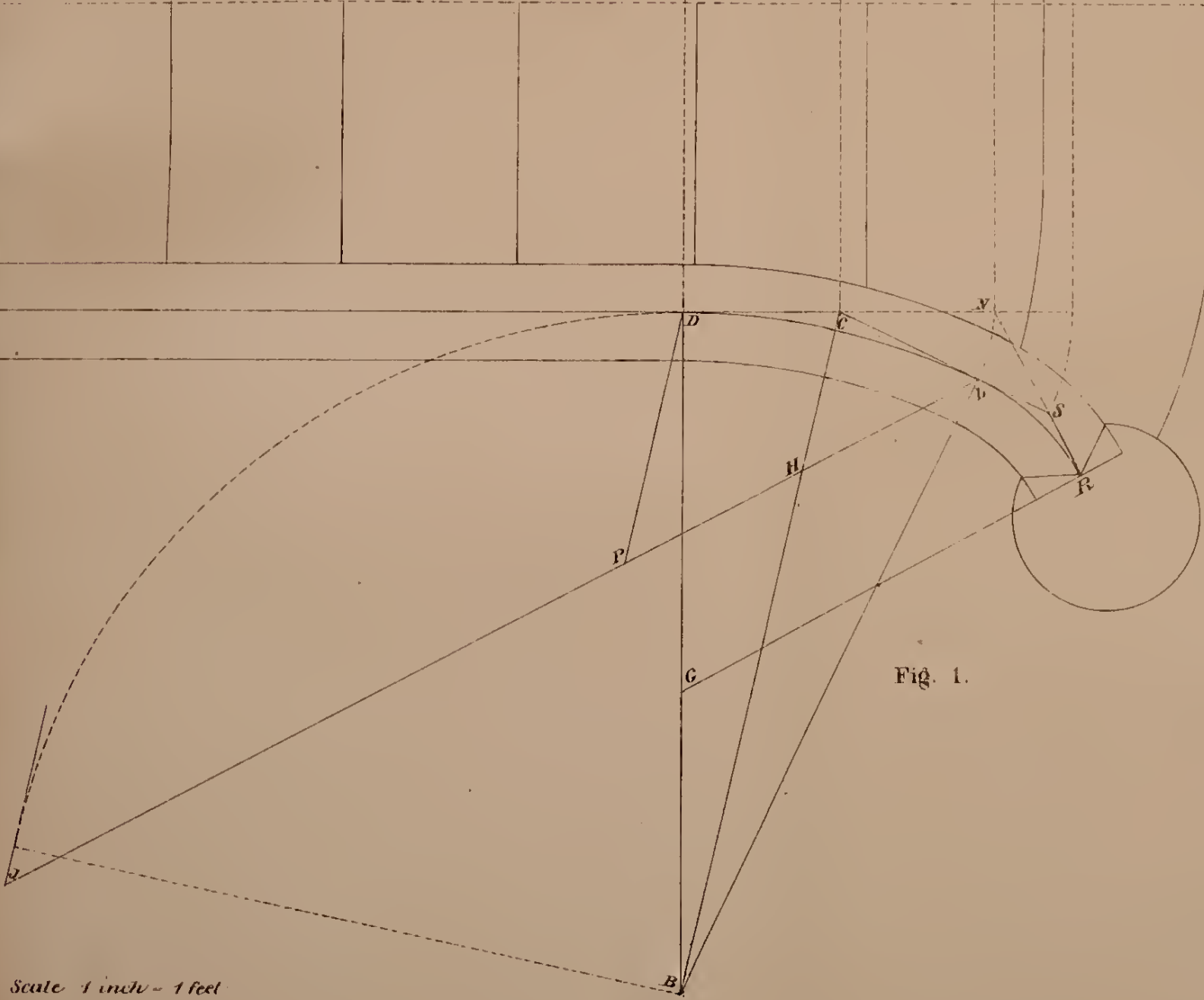

Fig. 1.

Scale 1 inch = 1 foot



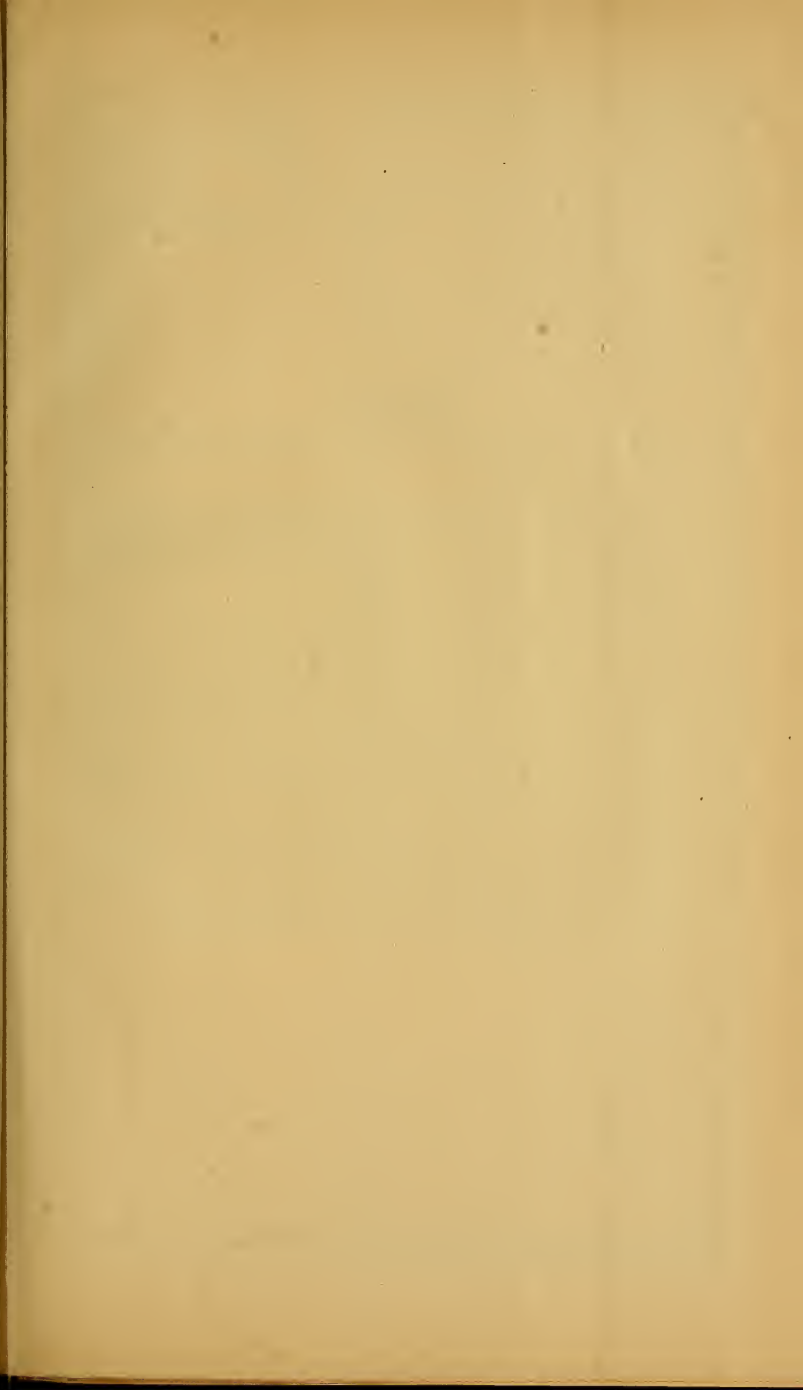

Plate 28

Exhibits the ground plan and elevation for a platform staircase, the risers placed beyond the cylinder.

To find the length of the major axis of the elliptic curve for the centre of the mould, draw lines from D and H, Fig. 1, parallel to C J indefinitely. Set up from D to S, equal to B S, Fig. 2, draw P S, and extend to R; then J R equals half of the length of the major axis, and P S determines the length of the curve required for the mould.

To draw the mould at Fig. 3, draw the major axis indefinitely. To find the points for the pins, to describe the centrecurve, square up from C to B, equal to C P, Fig. 1. From the point B as centre, with J R, Fig 1, as radius, describe arcs, cutting the major axis at 2 and 3, the points required. To find the points, to cut the curve, set up from the major axis, equal to L J, Fig. 2; from the point, draw a line parallel to the major axis, cutting the curve at J. From the point J as centre, with P S Fig. 1, as radius, describe an arc, cutting the curve at P. For the direction of the straight wood, draw J H, equal to S L, Fig. 2, and P H equal to N L, Fig. 2. For the width of the mould, and the points for the pins, to describe the outside and inside curves, set off each way from B, half the width of the rail; from the points draw lines parallel to B 2 and B 3, to intersect the major axis. The bevel for the centre joint is shown at A, for the straight wood at L.

Fig. 3.

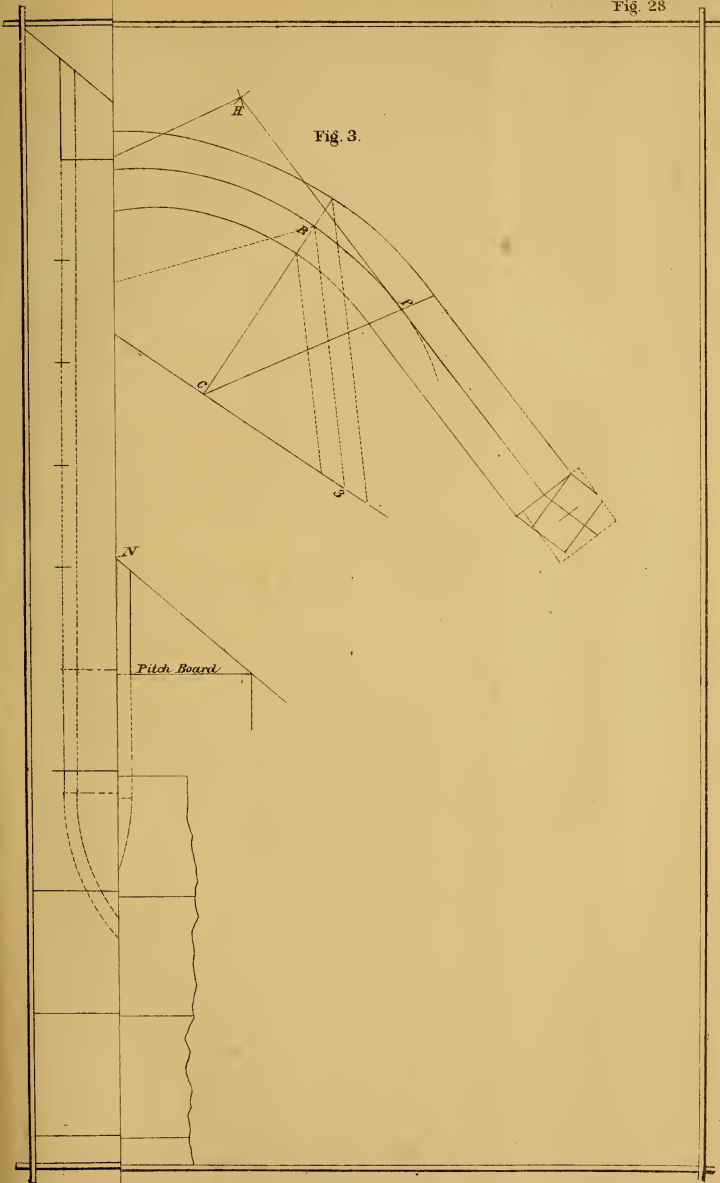

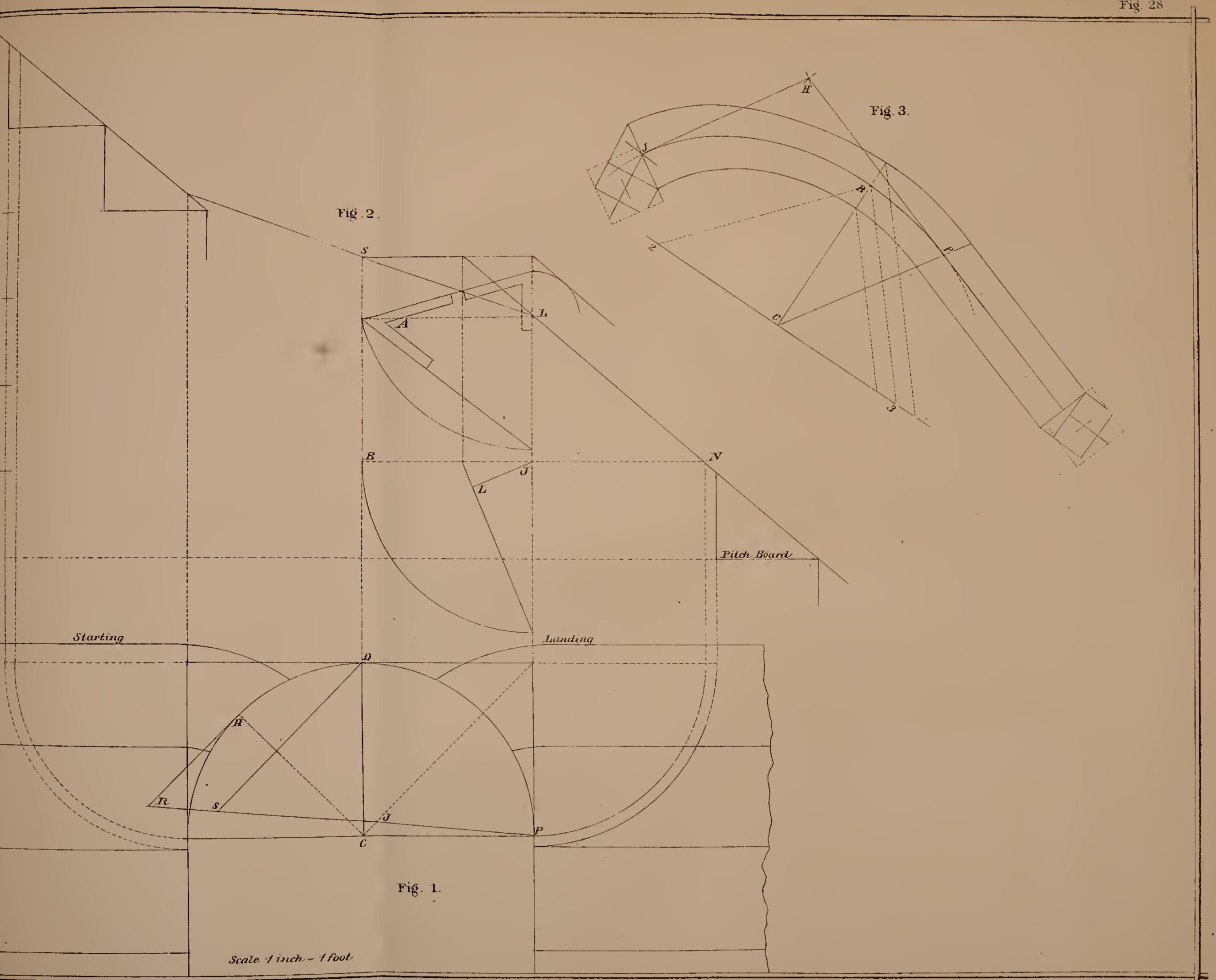

Fig. 2.

Fig. 3.

Fig. 1.

Scale 1 inch = 1 foot





Plate 29

Exhibits the ground plan and elevation, for a staircase with a semi-circle of winders ; the wreath formed in three pieces.

To find the length of the major axis of the elliptic curve, for the centre of the mould, draw $D S$, Fig. 1, equal to $L E$, Fig. 2; join $J S$ and extend to R ; then $P R$ equals half the length of the major axis required.

To draw the mould at Fig. 3, draw the major axis indefinitely. To find the points for the pins, to describe the centre curve, square up from C to D , equal to $C D$, Fig. 1; from the point D as centre, with $P R$, Fig. 1, as radius, describe arcs, cutting the major axis at 2 and 3, the points required. For the direction of the tangents, and length of curve, make $C B$ equal to $C N$, Fig. 1; from the point B as centre, with $E G$, Fig. 2, as radius, describe arcs, cutting the curve, at S and R ; join $B S$ and $B R$, the direction and length required. For the width of the mould, and the points for the pins, to describe the outside and inside curves, set off each way from D half the width of the rail; from the points draw lines parallel to $D 2$ and $D 3$, to intersect the major axis. The joints are cut at right angles to the tangents. One bevel answers for all the joints.

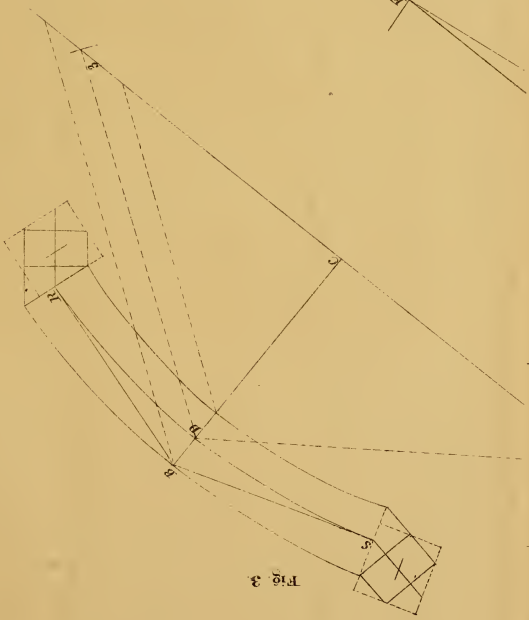
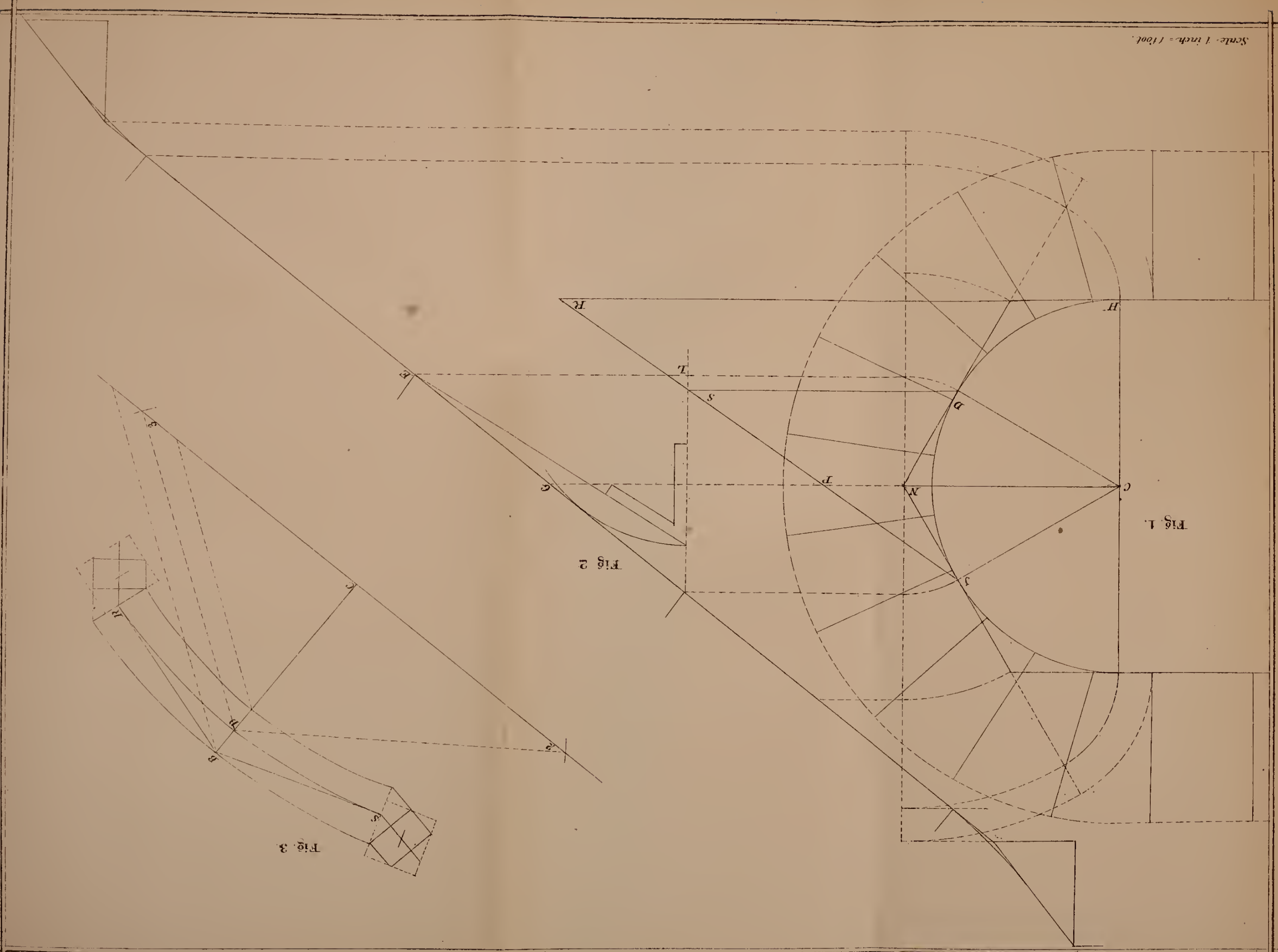
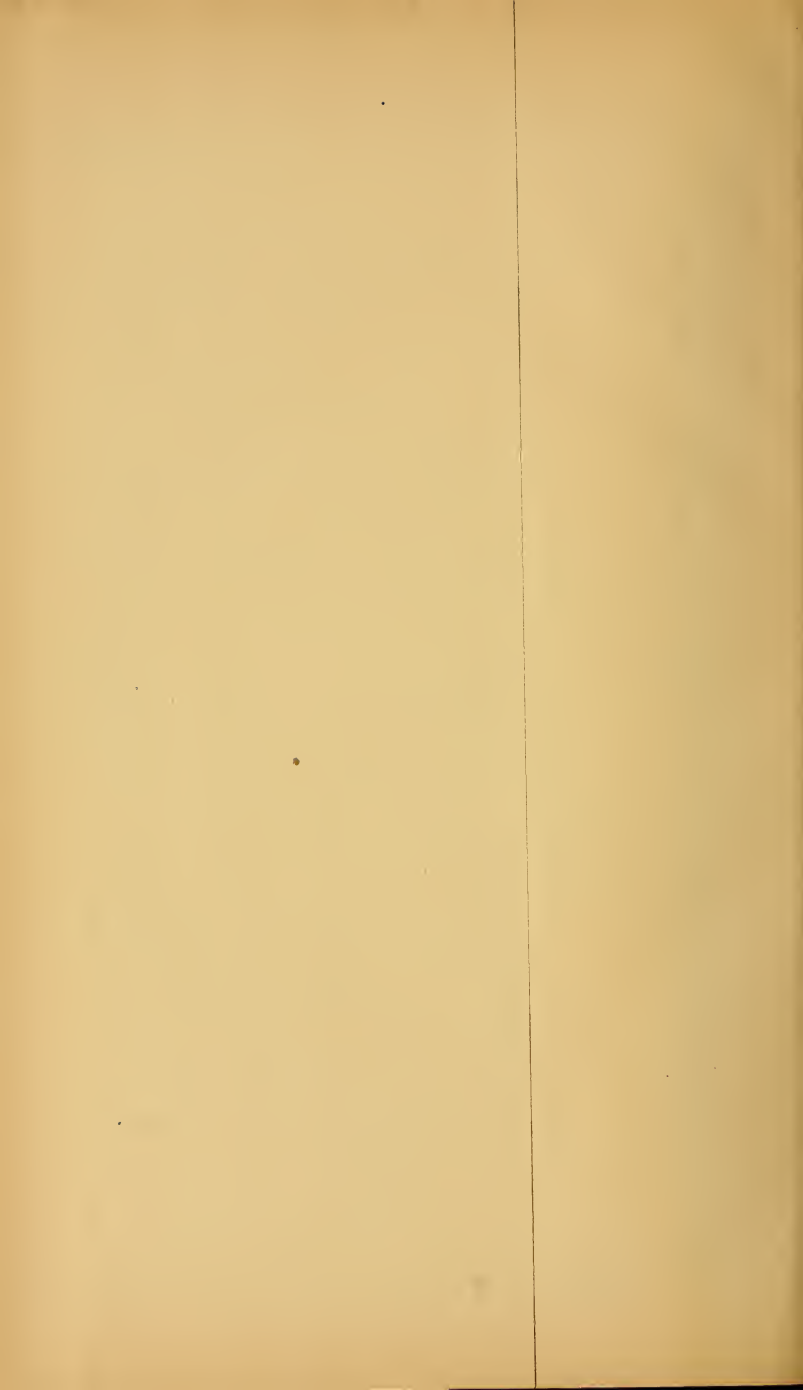

Fig. 3.





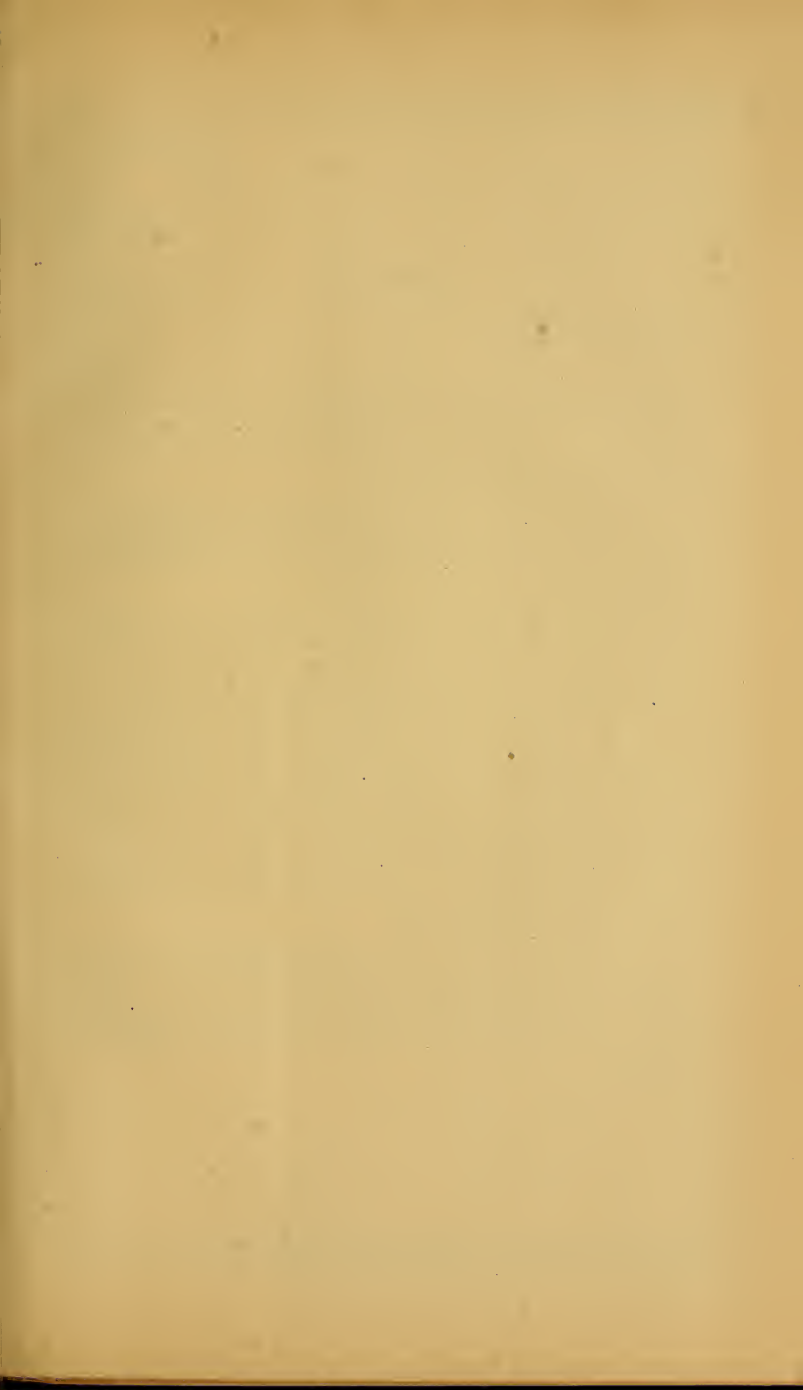

Plate 30

*Exhibits the ground plan and elevations, for two staircases starting with winders ;
the wreath in one piece.*

At Fig. 2, we have placed the centre of rail, at the newel, the height of one riser above the step, to increase the length of the easing, which added to the length of short baluster, gives the length of the newel, from the step to the cap. The pitches over the winders, are drawn, to give an easy and graceful curve to the rail when finished.

To find the major axis of the elliptic curve for the centre of the mould, draw *N P* and *D S*, Fig. 1, parallel to *C R*, indefinitely; set up from *D* to *S*, equal *G J*, Fig. 2, join *H S* and extend to *P*; then *R P*, equals half the length of the major axis, and *H S*, determines the length of the curve required for the mould.

At Fig. 3, draw the major axis indefinitely. To find the points for the pins, to describe the centre curve, square up from *C* to *D*, equal to *C H*, Fig. 1. From the point *D* as centre, with *R P*, Fig. 1, as radius, describe arcs, cutting the major axis at 3 and 4, the points required. For the point to cut the curve, set up from the major axis, equal to *N 4*, Fig. 2, from the point, draw a line parallel to the major axis, cutting the curve at *S*; from the point *S*, as centre, with *H S*, Fig. 1, as radius, describe an arc, cutting the curve at *B*. For the direction of the straight wood, draw *B H*, equal to *S 4*, Fig. 2, and *S H*, equal to *J 4*, Fig. 2. For the width of the mould, and the points for the pins to describe the outside and inside curves, set off each way from *D* half the width of the rail; from the points, draw lines parallel to *D 3* and *D 4*, to intersect the major axis. The bevel for the joint at *S*, is shown at *B*, for the joint *L*, is shown at *T*, Fig. 2.

Fig. 4 is the same as Fig. 1, with two additional steps at the starting. Set up from the first step to the centre of rail, the difference in the heights of the newel and short baluster. Make *B A*, equal to *A B*, Fig. 4, describe the curve for the easing; from the point *H*, draw the pitch line tangent to the curve. The mould at Fig. 6, is drawn in the same manner as that shown at Fig. 3.

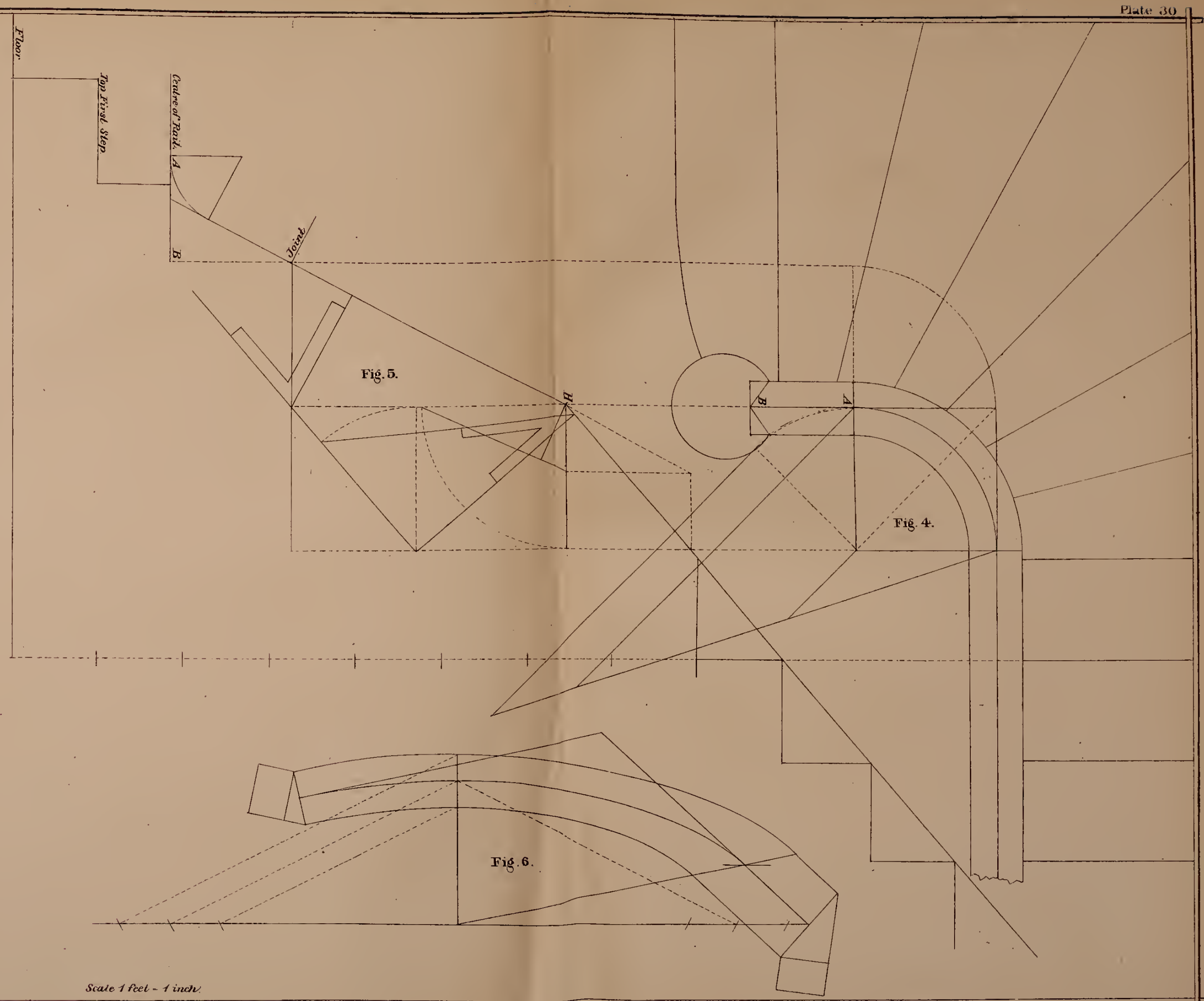
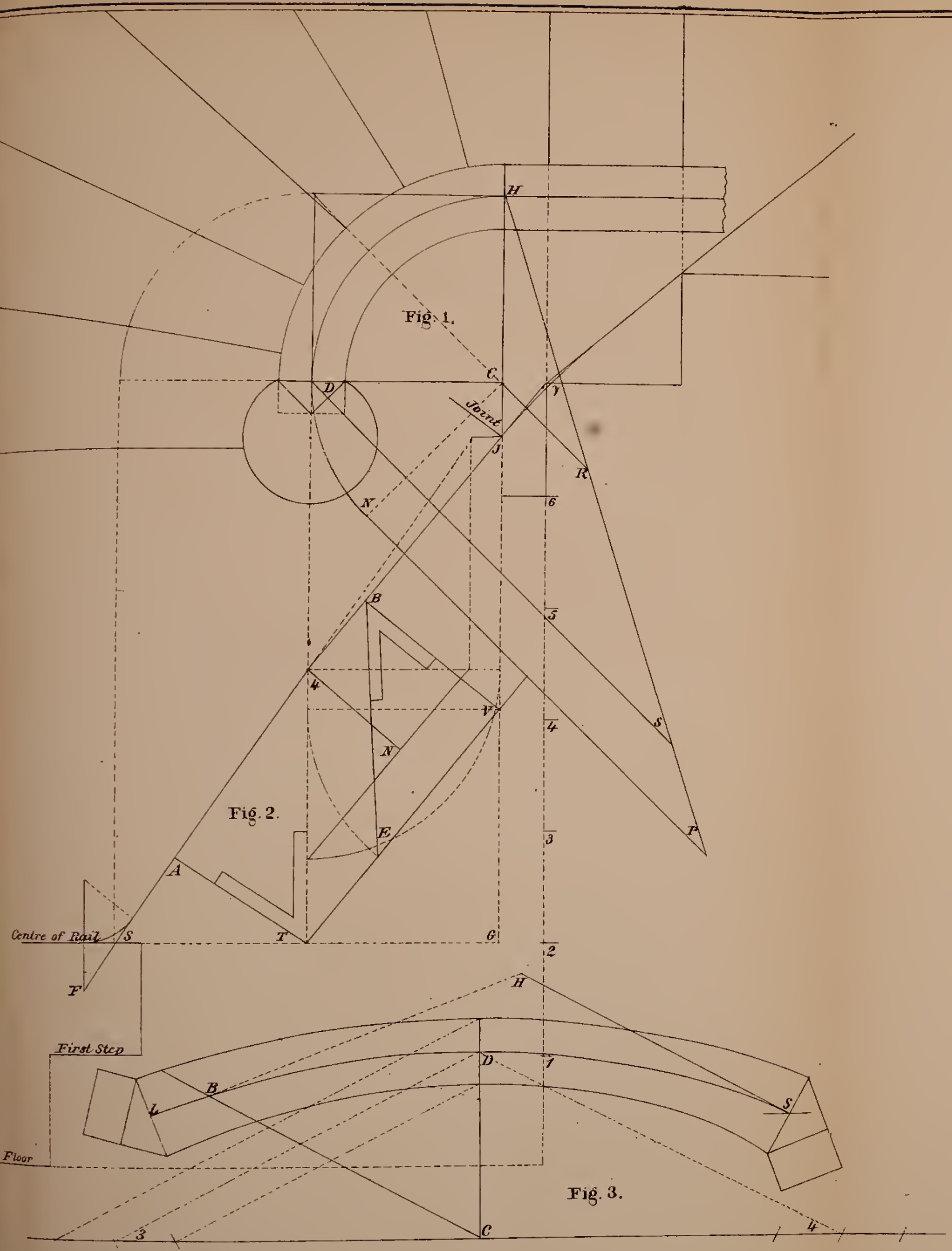

Scale 1 foot - 1 inch.



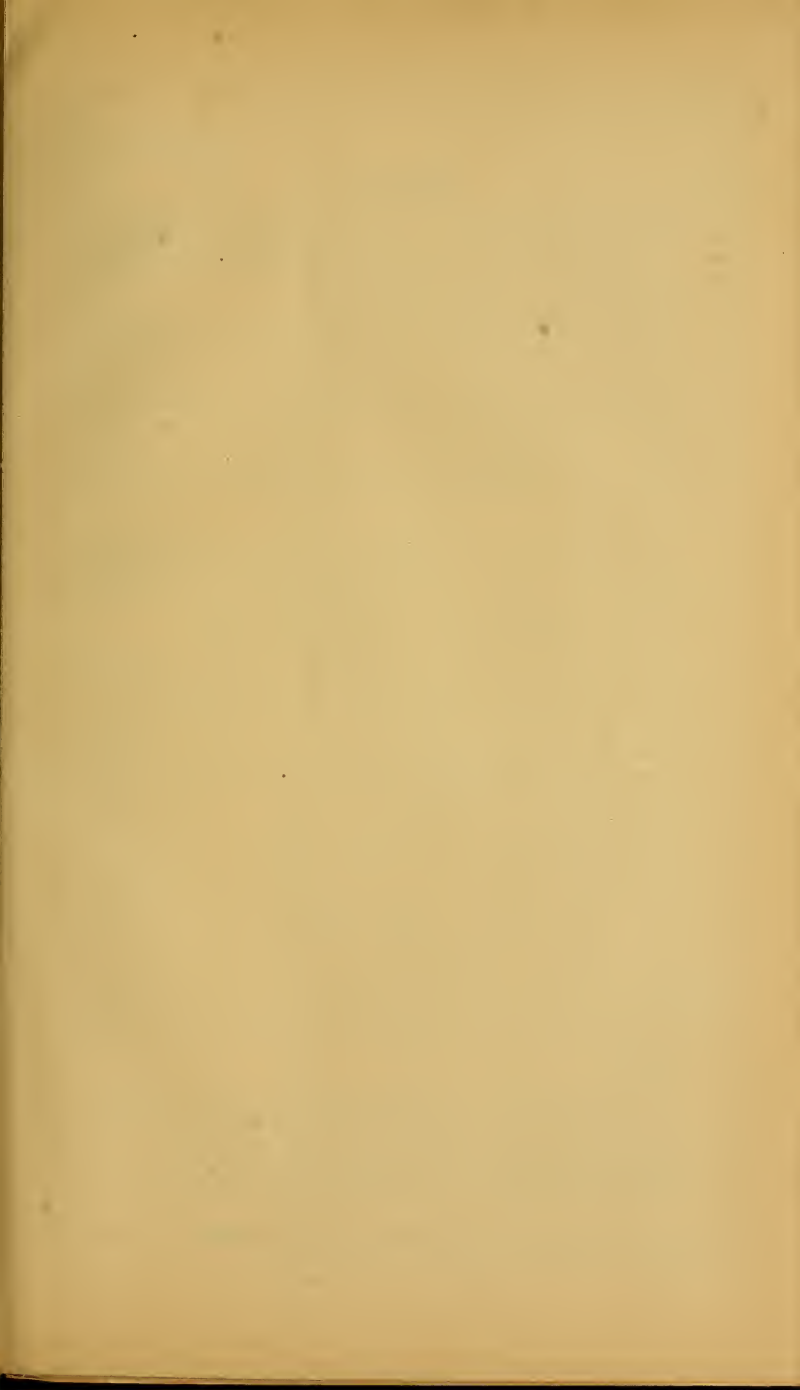

Plate 31

Exhibits the ground plan for a circular staircase ; the wreath in four pieces.

To find the common pitch, at Fig. 2, extend the tangent C D to A; at right angles to A C, draw A J, equal to five risers, join C J; then C J is the pitch of the tangents, that meet at the joints F C and N.

At Fig. 1, extend the tangent, S B, to V, equal to B F; from the points V B S, and A, draw lines parallel to O S, and at right angles V A, indefinitely. At any point H, Fig. 3, square over for the first step; set up from E to C the height of two risers, from H to R the height of five risers, and from E to F, the difference in the height of the newel and short baluster; join R C and extend to S, then R and S are the points from which the pitches are drawn. Draw R P the common pitch, or the same inclination as J C Fig. 2; join P S and extend to J; then R P, P L and L J are the tangents required for the mould.

To find the length of the major axis of the elliptic curve required for the of the mould: At Fig. 1, draw lines from F and N, parallel to O B, indefinitely; set up from F to K, equal to N R, Fig. 3; join S K, and extend to L; then W L equals half the length of the major axis required.

The mould for the wreath, at the starting, is shown at Fig. 5. Draw the major axis indefinitely. To find the points for the pins, to describe the centre curve, square up from C to D, equal to O S, Fig. 1, from the point D as centre, with W L, Fig. 1, as radius, describe arcs, cutting the major axis, at 2 and 3, the points required; set up from C to S, equal to O B, Fig. 1. From the point S as centre, with P R, Fig. 3, as radius, describe arcs, cutting the curve at R and L; draw S R, and S L indefinitely. For the width of the mould, and the points for the pins, to describe the outside and inside curves, set off each way from D half the width of the rail; from the points, draw lines parallel to D 2 and D 3, to intersect the major axis. To draw the extension of the mould, standing over the curve S 2, on the plan, set off from S to T, equal to P L, Fig. 3, and from T to H, equal to L J Fig. 3; draw T P and H J at right angles S H, make T P, equal to R S, and H J equal to 2 3, Fig. 1. At Fig. 3, 4 5 equals the width of the rail, then L 5 is the width of the mould at J; find the centres on the line, T P as shown by the dotted lines, and with the compasses, describe the curves, tangential to the elliptical curves, all ready drawn. The bevels for the joints are shown at Fig. 3.

To find the length of curve on the plan, for the wreath at the landing: At Fig. 4, from the point N, draw the common pitch indefinitely; set up from the line N B, to the floor, the height of two risers, and from the floor to the centre of the level rail, half the height of one riser from the point to bore for the first baluster on the floor; from the point, draw a line parallel to N

Fig. 3.

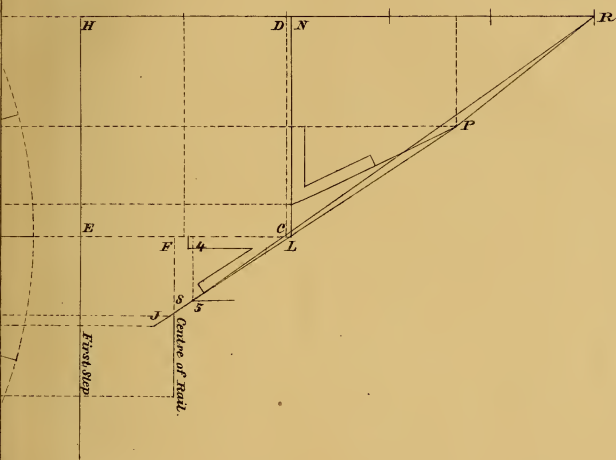
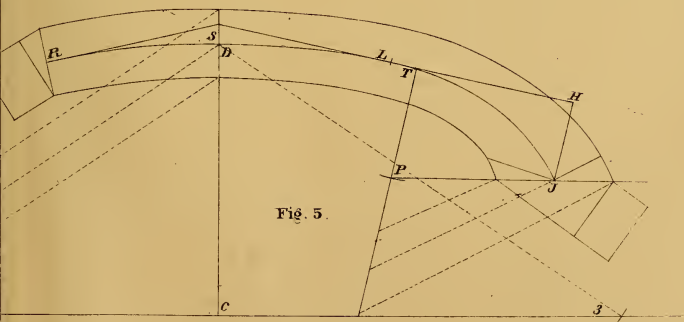
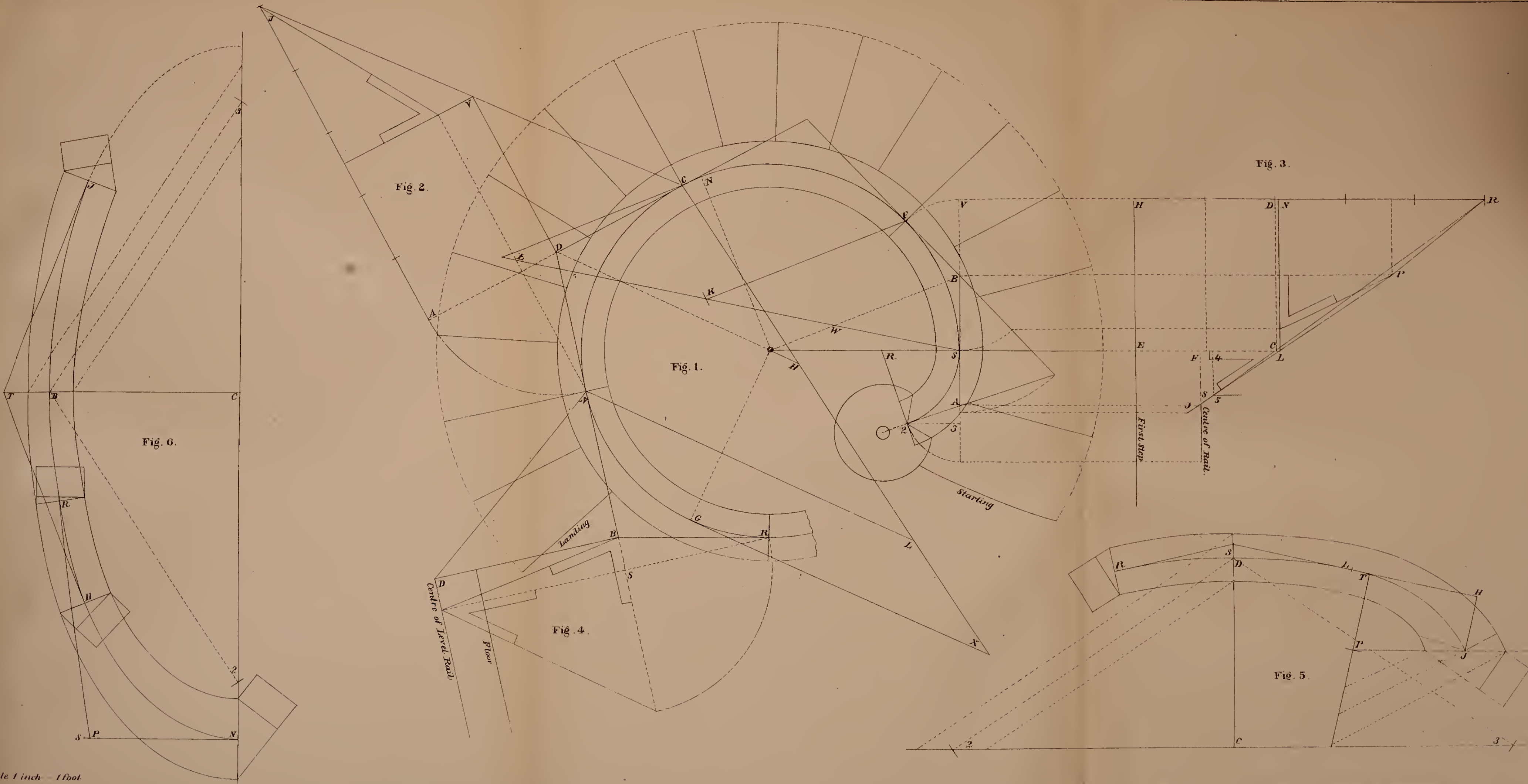

Fig. 5.





Scale 1 inch = 1 foot.



B, cutting the pitch at D; from the point D, draw D B at right angles to N B; from the point B as centre, with B N as radius, describe an arc, cutting the curve at R; join B R, then N R is the length of curve required.

To find the length of the major axis of the elliptical curve, required for the centre of the mould, shown at Fig. 6: Draw lines from N and G, Fig. 1, parallel to O D indefinitely. Set up from N to L, equal to A J, Fig. 2, draw C L and extend to X; then H X equals half the length of the major axis.

At Fig. 6, draw the major axis indefinitely. To find the points for the pins, to describe the centre curve, from the point B as centre, with H X, Fig. 1, as radius, describe arcs, cutting the major axis at 2 and 3, the points required. For the width of the mould, and the points for the pins, to describe the outside and inside curves, set off each way from B half the width of the rail; from the points draw lines parallel to B 2 and B 3, to intersect the major axis. For the length of curve required for the wreath, standing over C N on the plan, set up from C to T, equal to O D, Fig. 1. From the point T, as centre, with C V, Fig. 2, as radius, describe arcs, cutting the curve at H and J; join T H and T J, the lines from which to square the joints. The bevel is shown at Fig. 2.

For the length of the mould at the landing, square up from N to S, equal to B R, Fig. 4. From the point S, as centre, with N D, Fig. 4, as radius, describe an arc, cutting the curve at R. For the direction of the tangent, set up from N to P, equal to S R, Fig. 4, draw P R, the direction required. The bevels for the joints are shown at Fig. 4.

Plate 32

Exhibits the ground plan of an elliptical staircase, the plank for the wreaths sawed square to a parallel width, the joints cut at right angles to the face of the plank.

To find the common pitch, at Fig. 1, extend the tangent A B to C, draw A D at right angles to A C, equal to seven risers; join C D, then C D is the pitch of the tangents that meet at the joints L and A.

The mould for the centre wreath is shown at Fig. 3. Draw the dotted chord A L, square up from A and L indefinitely. Through the point B, draw E F, parallel to the dotted chord; make E H equal to A D, Fig. 2; join F H, produce O B to N; draw F R and H J at right angles to F H, equal to E A and F L; join N R and N J, which should equal P C and P D, Fig. 2; draw any number of ordinates and transfer the distances, through the points trace the mould. The bevel for the joint is shown at Fig. 2.

At Fig. 4, is shown the development of the tangents, at the starting. From the point A, draw the first step; set up to H the centre of rail four inches, which, added to the short baluster, gives the height of the newel; set up from A to B five risers, draw B C the common pitch, join C H. At Fig. 1, extend the tangent L D to H, then L H equals S D, Fig. 4; from the point J, draw J H, the directing ordinate, indefinitely; from the points L and D, draw lines parallel to J H; through the point D, draw the seat at right angles to J H; set up from R to G, equal to S B, Fig. 4; square up from K to F, equal to J 3, Fig. 1, and from G to P, equal to L 2, Fig. 1; join S F and S P, then S P will equal C B, and S F will equal C L, Fig. 4; draw any number of ordinates from the plan, transfer the distances, and through the points trace the mould. The bevel for the joint F, is shown at C; for the joint P, at S, Fig. 4.

The mould for the quadrant at the scroll, is found by drawing 5 7, equal to H L, Fig. 4, and 7 8 equal to 5 J. To find the points for the pins, to describe the centre curve, from the point 8 as centre, with 8 9 as radius, describe arcs, cutting the line 5 7, the points required. For the width of the mould and the points for the pins, to describe the outside and inside curves, set off each way from 8 half the width of the rail; from the points draw lines parallel to 8 4 to intersect the line 5 7. The bevel for the joint at 5 is shown at L, Fig. 4.

The length of curve on the plan, required for the mould, at the landing, is found at Fig. 6. From the point A, draw the pitch line parallel to C D, Fig. 2, indefinitely; set up from the line A L, the height of four risers, to the floor; set up from the floor to centre of level rail, half a rise from the point to bore for the first baluster; from the point, draw a line to intersect the pitch line at C; from the point C, drop a line at right angles to A L,

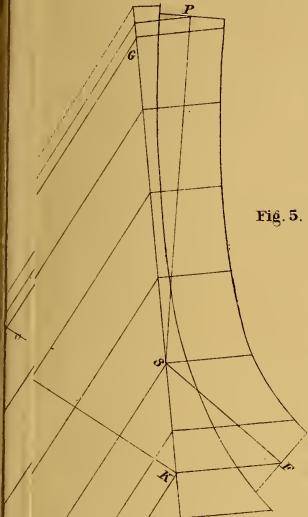

Fig. 5.

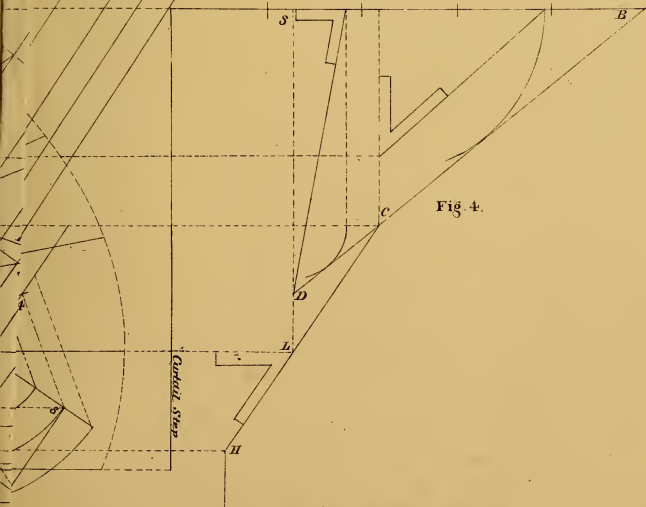
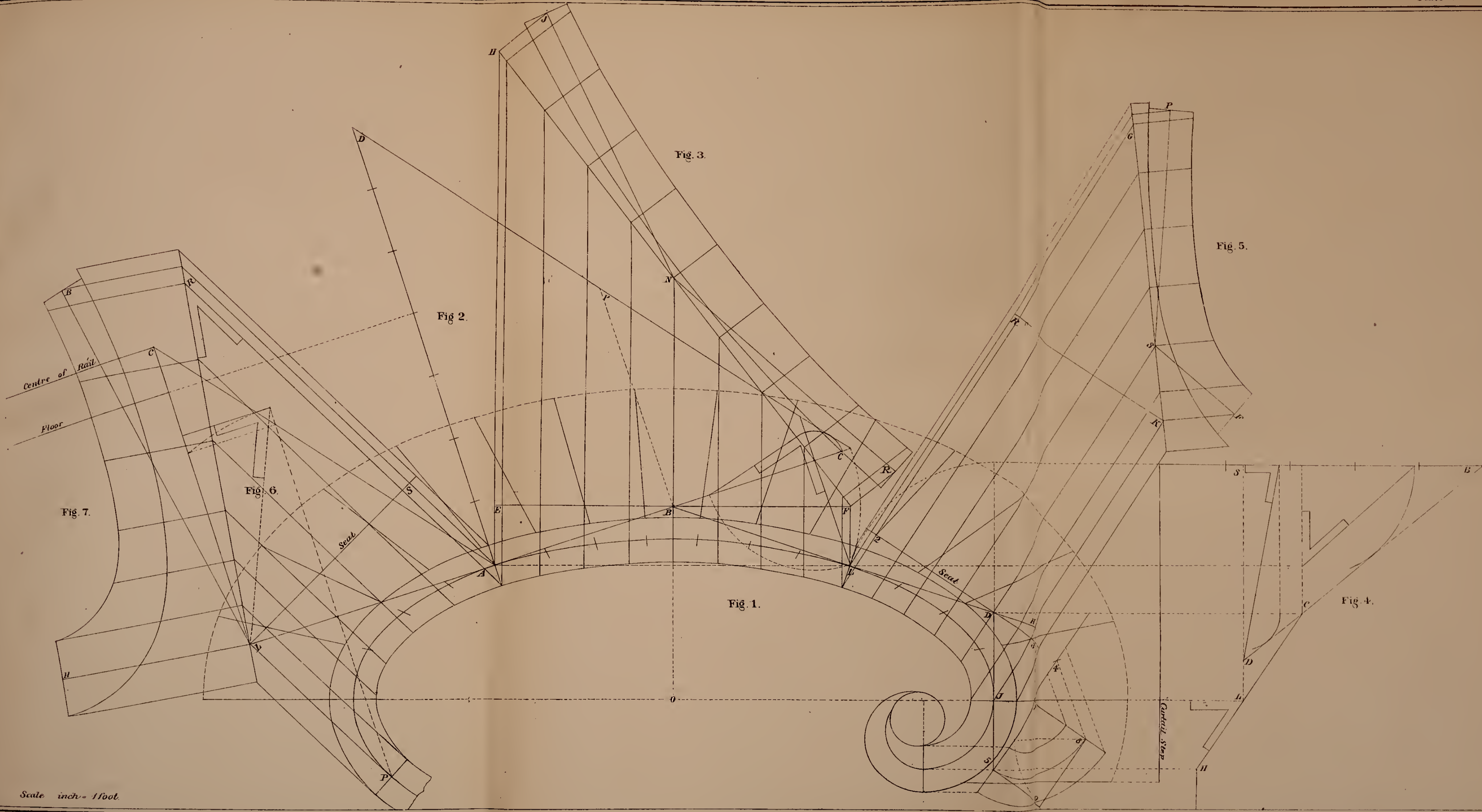
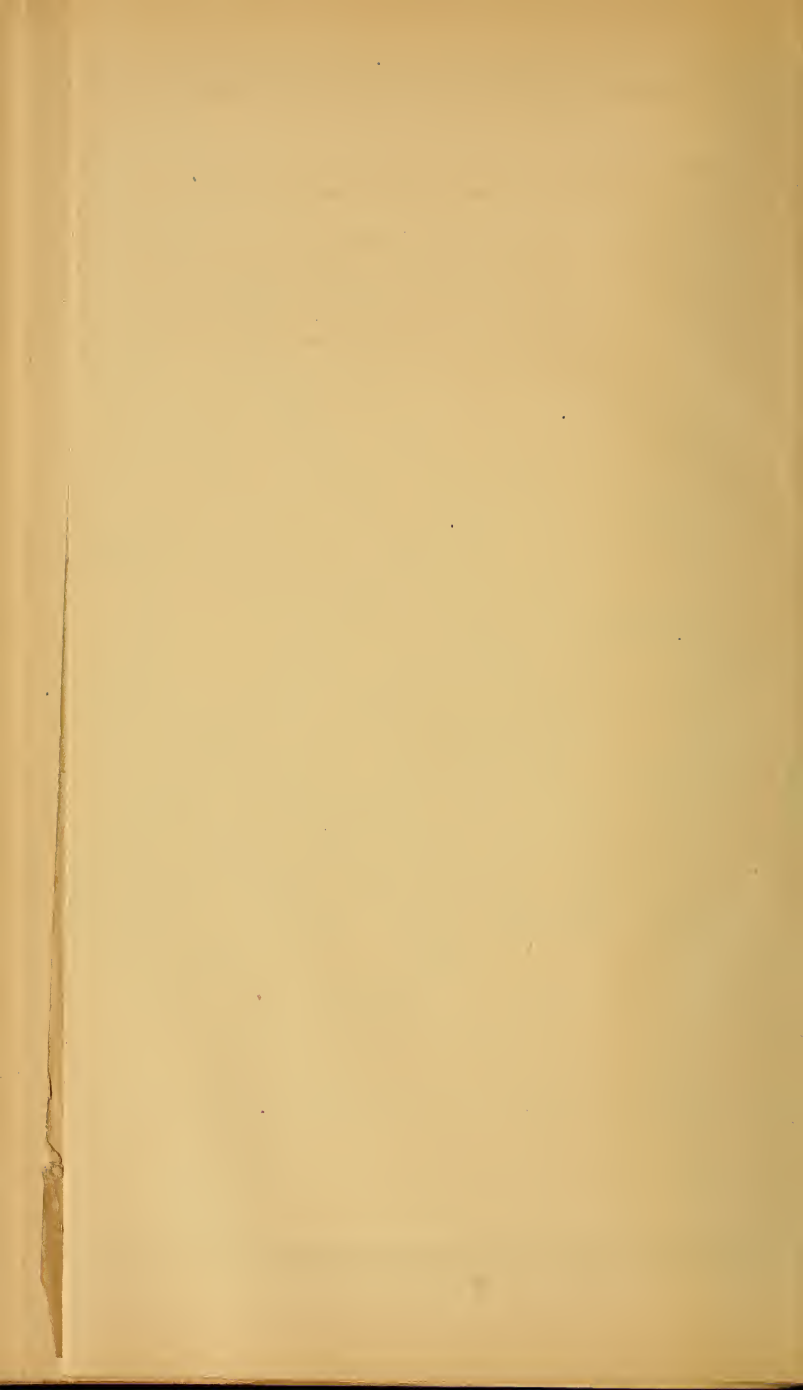

Fig 4.



Scale inch = 1 foot.



cutting the line from A at L; draw LP tangent to the curve on the plan, then AP is the length of curve required, and PL is the directing ordinate for the mould.

To draw the mould at Fig. 7: From the point L, draw the seat at right angles to LP; set up from S to R, equal to LC, Fig. 6; join LR; square up from L to H, equal to LP; from R to B, equal to SA; join LB, which should equal AC, Fig. 6. Draw the ordinates, transfer the distances, and through the points trace the mould. The bevel for the joint H, is shown at R; for the joint B, at Fig. 6.

LIST OF PRACTICAL BOOKS

PUBLISHED AND FOR SALE BY

A. J. BICKNELL & CO.,

27 WARREN STREET, NEW YORK.

Atwood's Architectural Proportions.....	\$1 00
Atwood's Country and Suburban Residences	1 50
Baumann's Foundations.....	75
Bicknell's Village Builder and Supplement.....	12 00
Bicknell's Supplement to Village Builder	5 00
Bicknell's Detail Cottage and Constructive Arch.....	10 00
Bell's Carpentry Made Easy.....	5 00
Boyce's Art of Lettering.....	3 50
Boyce's Modern Ornamenter.....	3 50
Burns' Architectural Drawing-Book.....	1 00
Burns' Illustrated and Perspective Drawing-Book	1 00
Burns' Ornamental Drawing-Book	1 00
Butler's Ventilation of Buildings	50
Cummings & Miller's Architectural Details.....	10 00
Cummings' Architectural Details.....	10 00
Croff's Front Entrance Doors.....	5 00
Croff's Progressive American Architecture.....	10 00
Copley's Plain and Ornamental Alphabets.....	3 00
Dearborn's Text Book of Letters.....	2 00
Dearborn's Scrolls.....	2 50
Eveleth's School-House Architecture.....	6 00
Esser's Draughtsman's Alphabets.....	1 50
Free Hand Drawing.....	50
Gould's Carpenter's and Builder's Assistant.....	3 00
Guillaume's Interior Architecture	3 00
Harney's Barns and Out Buildings.....	6 00
House of God.....	1 75
How to Paint	1 00
Hussey's National Cottage Architecture.....	6 00
Hallett's Builders' Specifications.....	1 75
Hallett's Builders' Contracts.....	10
Hinkle & Co's Book on Building; paper, \$1 00; cloth.....	1 50
Lewis' Practical Poultry Keeper	1 50
Lakey's Village and Country Houses.....	6 00
Mechanic's Own Book.....	1 50
Mechanic's Text Book.....	75
Mitchell's Stepping Stone to Architecture.....	60
Ornamental Designs for Fret Sawing.....	60
Sawyer's Fret Sawing.....	1 50
Silloway's Carpentry	2 00
Tower's Bridge Building.....	2 00
Vose's Manual for Railroad Engineers.....	12 50
Vogde's Price-Book; cloth, \$1 50; morocco.....	2 00
Woodward's National Architecture.....	12 00
Woodward's Country Homes.....	1 50
Withers' Church Architecture.....	15 00
Williams' Window Gardening.....	1 50
Wooden and Brick Buildings, with details, 2 vols., \$9 00 each.....	18 00

All the above books mailed and post paid on receipt of price. Illustrated Catalogue mailed free to any address.

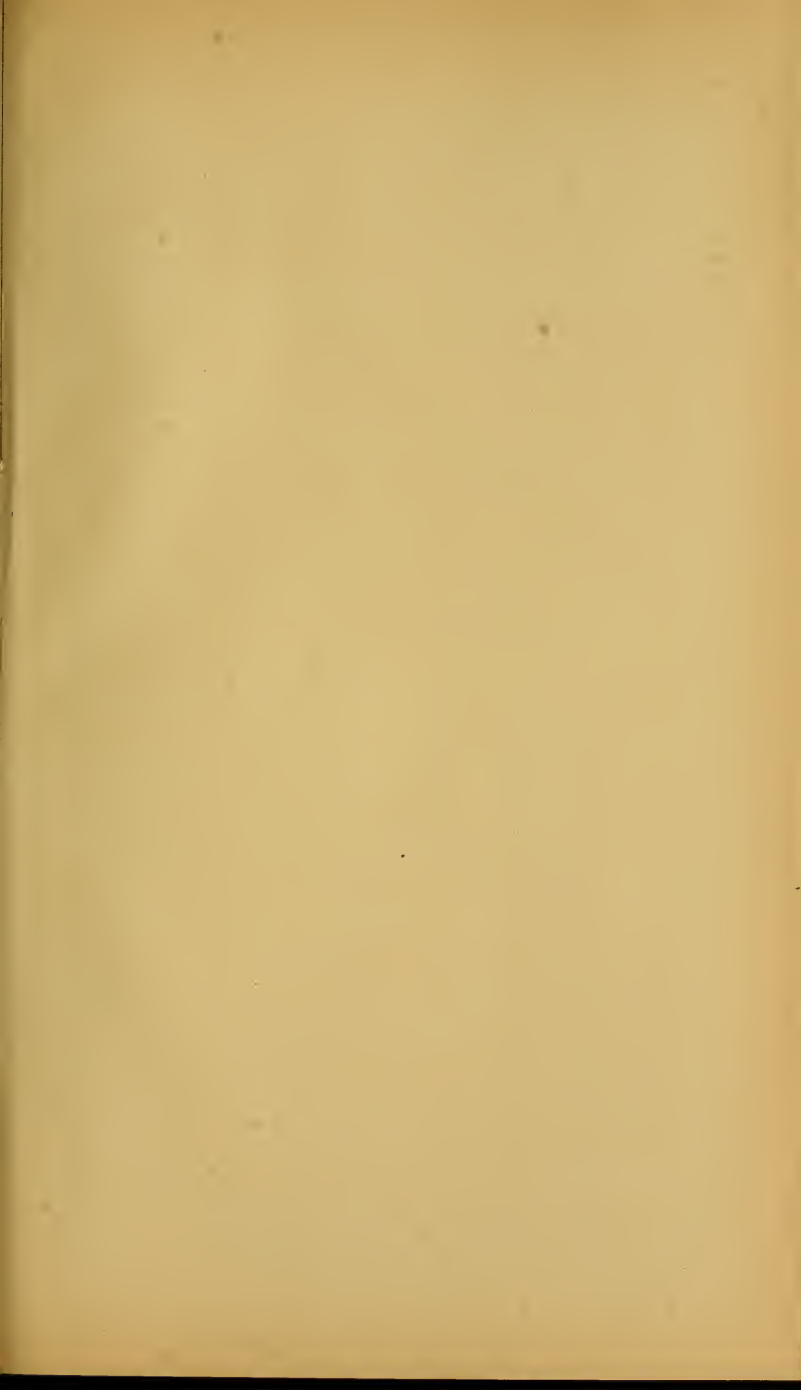



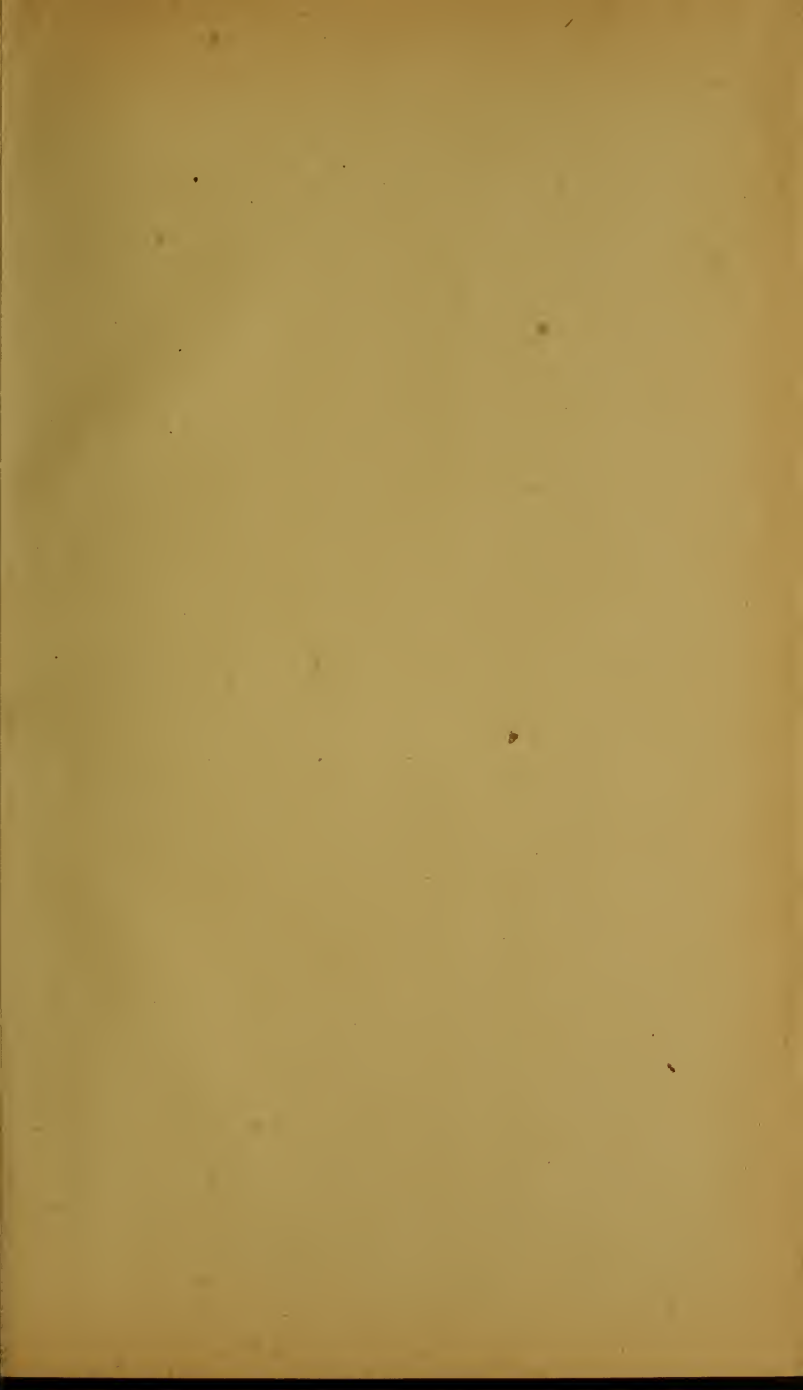

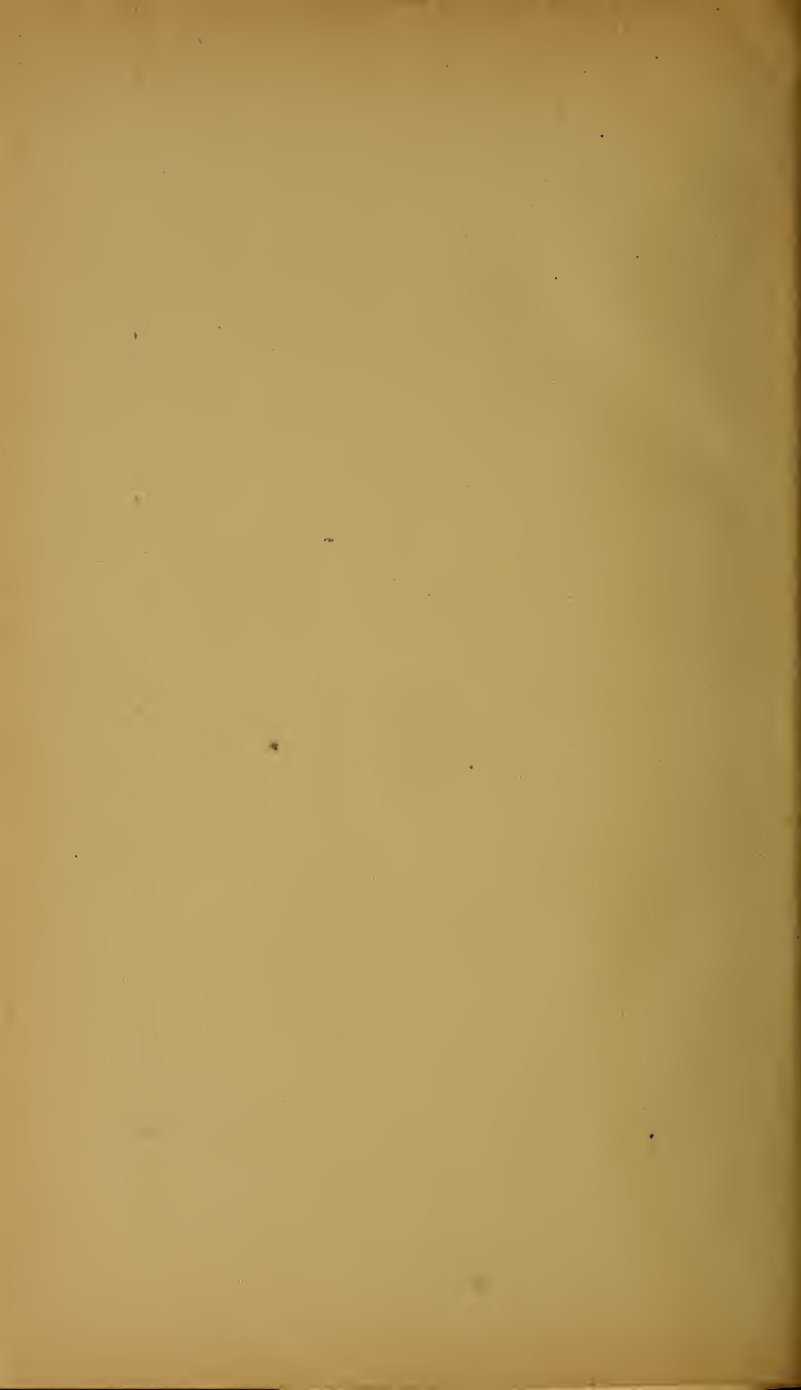

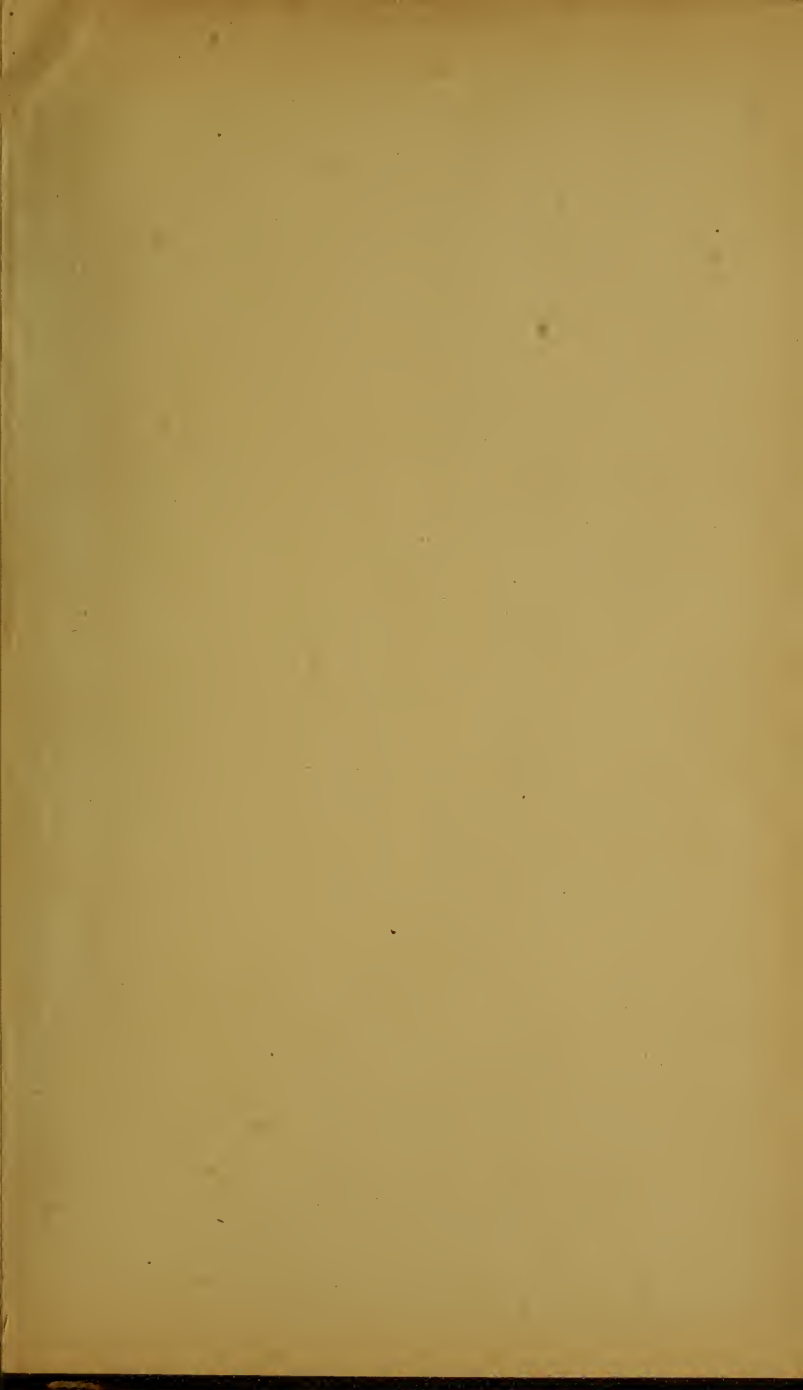

LIBRARY OF CONGRESS



0 021 218 402 0