

*New York
State College of Agriculture
At Cornell University
Ithaca, N. Y.*

Library

Cornell University Library
SB 321.W28

Vegetable gardening.



3 1924 000 880 967

mann

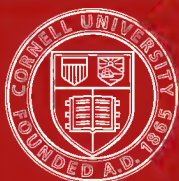

Cornell University
Library

The original of this book is in
the Cornell University Library.

There are no known copyright restrictions in
the United States on the use of the text.

<http://www.archive.org/details/cu31924000880967>

VEGETABLE GARDENING

By

RALPH L. WATTS

*Professor of Horticulture in the Pennsylvania
State College*

ILLUSTRATED

NEW YORK

ORANGE JUDD COMPANY

LONDON

KEGAN PAUL, TRENCH, TRÜBNER & CO., Limited

1916

Copyright, 1912, by
ORANGE JUDD COMPANY
All Rights Reserved

Entered at Stationers' Hall
LONDON, ENGLAND

PRINTED IN U. S. A.

PREFACE

In the preparation of this volume the author has had a twofold purpose, first, to meet the demands of instructors desiring a textbook on vegetable gardening and, second, to present in an organized form data of value to all classes of vegetable growers. The work relates to the culture rather than to the systematic study of vegetables, although some attention is given to a description and classification of the more important garden crops. A special effort is made to state the fundamental principles involved in the various operations of vegetable gardening, while at the same time methods are discussed fully, and frequent reference is made to the practice of vegetable growers in various sections of the United States and Canada.

Numerous bulletins of the agricultural experiment stations and of the United States Department of Agriculture, and books and periodicals relating to garden topics, were consulted during the preparation of the manuscript, and many references are cited throughout the volume. The general plan of the book is in accordance with the recommendations of the Association of American Agricultural Colleges and Experiment Stations. It is hoped that the data gleaned from the author's experience as a commercial grower of vegetables, from a study of many successful market gardens and truck farms, and from the literature of the subject, will be useful to students as well as to practical gardeners.

Most of the photographs were made by the author, although many friends assisted in securing the necessary illustrative material. All the drawings have been prepared by Mr. B. F. Williamson from sketches or photographs furnished by the author. Special acknowledg-

ment is made to the Pennsylvania State College for the use of numerous negatives, and to Professors J. W. Gregg and C. E. Myers of this institution for assistance in making photographs; to Professor L. C. Corbett and Professor W. W. Tracy, of the United States Department of Agriculture, for Figures 82, 84, 90, 93, 94, 95, 100, 102, 103, and 104; to H. B. Fullerton, of the Long Island Railroad Experimental Stations, for Figures 50, 54, 73, 81 and 75; to Professor C. G. Woodbury, of the Indiana Experiment Station, for Figures 87 and 88; to Prof. H. H. Whetzel, of the Cornell Experiment Station, for Figures 62 and 72; to Dr. W. L. Howard, of the Missouri Experiment Station, for Figure 24; to Professor John W. Lloyd, of the Illinois Experiment Station, for Figure 89; to R. H. Garrahan, Kingston, Pa., for Figure 21; to H. R. Pennypacker, Phoenixville, Pa., for Figure 78; to Lord & Burnham, for Figure 19; to the Skinner Irrigation Co. for Figures 15, 16 and 17; to Robert J. Walton, Hummelstown, Pa., for Figures 55 and 76; to F. J. Zuck, Erie, Pa., for Figure 56; and to J. G. Curtiss, Rochester, N. Y., for Figures 69, 70 and 71.

RALPH L. WATTS.

State College, Pa., 1911.

CONTENTS

CHAPTER I

Page

A GENERAL VIEW ----- I

Vegetable gardening—Market gardening—Trucking or farm gardening—Vegetable forcing—Home vegetable gardening—Ideals—Profits—The outlook—Capital required—Labor problems.

CHAPTER II

SELECTION OF LOCATION ----- II

Markets—Soil—Climate—Water supply—Contour of land—Aspect—Windbreaks—Roads—Shipping facilities—Methods of selling—Price of land—Labor supply—Manure supply—General remarks.

CHAPTER III

SOILS ----- 17

Classification of soils—Soil type—Soil class—Soil series—Atlantic and gulf coastal plains—Bastrop series—Crockett series—Laredo series—Lufkin series—Norfolk series—Orangeburg series—Sassafras series—Susquehanna series—Webb series—Collington sandy loam—Hempstead loam—Muck and peat—River flood plains—Huntingdon series—Wabash series—Wheeling series—Muck and peat—Piedmont plateau—Appalachian mountains and plateau—Limestone valleys and uplands—Glacial and loessial regions—Marshall series—Miami series—Miscellaneous types—Glacial lake and river terraces—Clyde series—Dunkirk series—Muck and peat—Pacific coast—Soil texture—Advantages of sand—Water content—Drainage—Chemical properties—Soil adaptation.

CHAPTER IV

TILLAGE AND TILLAGE TOOLS ----- 28

The object of tillage—The value of tillage implements—Plowing—Harrowing—Dragging—Soil preparation—Cultivation—Hoeing—Weeding—Care of tools and implements.



CHAPTER V

STABLE MANURES ----- 41

Extent used—Manure as a source of humus—Manure as a source of plant food—Horse manure—Cow manure—Hog manure—Sheep manure—Hen manure—Cost of horse manure—Transportation of manures—Fresh manure versus rotten manure—Composting manures—Time of application—Method of application—Rate of application—Night soil.

CHAPTER VI

GREEN MANURES AND COVER CROPS ----- 53

As a source of humus—Extent used—The selection of crop—Red clover—Mammoth clover—Crimson clover—Rye—Hairy vetch—Oats and Canada field peas—Cowpea—Soy bean—Fertilizing green manurial crops—When to plow under green crops.

CHAPTER VII

COMMERCIAL FERTILIZERS ----- 58

The necessity of commercial fertilizers—The use of nitrogen—The use of phosphoric acid—The use of potash—Rate of application—Dangers of excessive applications—The use of lime—Related questions—Methods of application—Purchasing fertilizers—The home mixing of fertilizers.

CHAPTER VIII

IRRIGATION ----- 72

The extent—Opportunities—Functions—The benefits—The furrow method—Hose applications—Subirrigation—The overhead system.

CHAPTER IX

INSECT ENEMIES AND DISEASES ----- 85

Importance of controlling—Preventive measures—Spraying—Spray pumps—Nozzles—Insecticides—Arsenate of lead—Paris green—Hellebore—Kerosene emulsion—Carbolic acid emulsion—Tobacco—Soaps—Miscellaneous insecticides—Bordeaux mixture—"Sticker" or adhesive.

CHAPTER X

SEEDS AND SEED GROWING -----	92
------------------------------	----

Importance of planting good seed—Breeding and selection—Commercial seed growing—Growing seeds at home—Harvesting, cleaning and curing—Preservation of seeds—Buying seeds—Seed guarantees—Change of seed—Novelties—Old versus new seed—Seed testing—The longevity of seeds.

CHAPTER XI

CONSTRUCTION OF HOTBEDS -----	103
-------------------------------	-----

The necessity of glass—The extent used—Location and arrangement—The pit—The frame—Sash—Manure and its preparation—Filling the pit—Other types of manure hotbeds—Heating frames by means of flues—Heating with steam and hot water—The uses of hotbeds.

CHAPTER XII

CONSTRUCTION OF COLD FRAMES -----	114
-----------------------------------	-----

Location and arrangement—Grading—The frame—Soil of the cold frames—Heating—The use of cold frames—Forcing boxes.

CHAPTER XIII

CONSTRUCTION OF GREENHOUSES -----	119
-----------------------------------	-----

Extent used—Advantages—The size—Location and position—Materials used in construction—Semi-iron type of construction—Forms of greenhouses—Walls—Roof construction—Glass—Glazing and painting—Ventilators—Beds, benches and walks—Steam versus hot water heating—Pipes and piping—The boiler—The workroom.

CHAPTER XIV

SEED SOWING -----	130
-------------------	-----

Soil selection and preparation—Moisture conditions—Proper soil temperature—When to sow—Quantity of seed to sow—Thinning—Depth of sowing—Soaking seeds—Broadcasting or drilling—Hand sowing—Sowing with machines—Firming the soil—Watering after sowing—Shading the seed bed.

	Page
CHAPTER XV	
TRANSPLANTING -----	139
Reasons for transplanting—Soil selection and preparation—When to plant—Markers and marking—Depth to transplant—Transplanting by hand—Watering—Shading—Transplanting with machines.	
CHAPTER XVI	
GROWING EARLY VEGETABLE PLANTS UNDER GLASS -----	151
Soil supply—Flats and plant boxes—Mats and shutters—Sowing—Care of seedlings—Transplanting—Care after transplanting—The use of mats—Hardening plants—Pots, sods and other devices.	
CHAPTER XVII	
MARKETING -----	162
Modern methods—The principles involved—Harvesting—Facilities for packing—Preparation for market—Packages—Grading—Packing—Advertising—Market wagons—Auto trucks—Transportation by water—Selling to the consumer—Selling to retailer—Selling to wholesaler—Distribution.	
CHAPTER XVIII	
CO-OPERATIVE ASSOCIATIONS -----	188
Historical—Objects—Character of organizations—Volume of business transacted—Capitalization—Management—Selling advantages—Savings—Fraternal advantages—Educational advantages—Co-operation relieves the producer—Uniformity—Distribution—Constitution and by-laws.	
CHAPTER XIX	
THE STORAGE OF VEGETABLES -----	193
Does storage pay—Harvesting vegetables to be stored—Storage houses—Pits and outdoor cellars—The house cellar—Burying—Cold frames.	
CHAPTER XX	
THE CLASSIFICATION OF VEGETABLES -----	196
Methods of classification—Requirements of the various groups.	

CHAPTER XXI

CULTURAL DIRECTIONS ----- 401

Artichoke, Globe—Artichoke, Jerusalem—Asparagus—
 Bean—Beet—Broccoli—Brussels sprouts—Cabbage—Car-
 rot—Cauliflower—Celeriac or turnip-rooted celery—Celery
 —Chard—Chicory—Chive—Collard—Corn salad—Cress
 —Cucumber—Dandelion—Dill—Eggplant—Endive—
 Garlic—Horseradish—Kale or borecole—Kohl-rabi—Leek
 —Lettuce—Martynia—Mint—Muskmelon—Mustard
 —Okra or, gumbo—Onion—Parsley—Parsnip—Pea—Pep-
 per—Pumpkin—Radish—Rhubarb—Rutabaga—Sage—
 Salsify—Savory—Shallot—Spinach—Squash—Sweet corn
 —Sweet potato—Thyme—Tomato—Turnip—Watermelon

CHAPTER XXII

CROP ROTATION ----- 472

A necessity—Relation to food supply—Relation to humus
 —Relation to toxics—Relation to insects and diseases—Re-
 lation to other factors—Examples.

CHAPTER XXIII

SUCCESSION AND COMPANION CROPPING ----- 475

Succession cropping—Companion cropping—Plans for
 companion cropping.

CHAPTER XXIV

THE HOME VEGETABLE GARDEN ----- 490

Importance—Aims—Location—Varieties—The use of
 glass—Management—Plans.

CHAPTER XXV

TABLES ----- 494

Vitality of seeds—Percentage of germination—Number
 of plants required an acre at various distances—Quantity
 of seed required an acre—Weight of one quart of seeds
 and number of seeds in one ounce.

CHAPTER XXVI

SUGGESTIONS ON LABORATORY WORK ----- 498

Importance—Methods—Definite lines of work.

LIST OF ILLUSTRATIONS

Fig.	Page
1 Plank Drag	32
2 Different Forms of Horse Cultivators.....	33
3 Different Forms of Hand Cultivators.....	35
4 Combination Hand Seed Drill and Cultivator.....	36
5 Different Forms of Hand Hoes.....	37
6 Different Forms of Horse Weeders.....	38
7 Different Forms of Hand Weeders.....	39
8 Hauling Manure Near Boston.....	45
9 Hauling Manure Near Philadelphia.....	46
10 Night Soil Tank Wagon Used Near Baltimore.....	51
11 Single-Row Fertilizer Distributor.....	66
12 Wheelbarrow Fertilizer Distributor.....	67
13 McWhorton Fertilizer Distributor.....	68
14 Lime Spreader	69
15 Drilling Machine for the Installation of the Skinner System of Irrigation	79
16 Nozzles for the Skinner System of Irrigation.....	80
17 Union for the Skinner System of Irrigation.....	81
18 Irrigation System Installed at the Pennsylvania State College	83
19 Sash for Hotbed or Cold Frame.....	107
20 Flue-Heated Frame	111
21 Steam-Heated Frame	112
22 Potatoes in Cold Frame Plat.....	114
23 Peppers in Cold Frames	115
24 Permanent Cold Frames	116
25 Cucumbers in Cold Frame Plat.....	117
26 Even-Span Greenhouses	123
27 Three-Quarter Span Greenhouse	124
28 A Common Form of Greenhouse Bracing.....	125
29 Different Forms of Hand Seed Drills.....	136
30 Lath Screen	138
31 Popular Marker	142
32 Homemade Marker	142
33 Different Forms of Dibbers.....	143
34 Different Forms of Trowels.....	143
35 Useful Plant Setter	144
36 Transplanting Board and Dibber.....	145
37 Dibbling Machine	146
38 Cabbage Plant Ready for Transplanting.....	147
39 Field Transplanter	149
40 Rye-Straw Mat	153
41 Flat of Cabbage Seedlings.....	155
42 Frame of Hardened Cabbage Plants.....	158
43 Paper Pots and Equipment for Making Them.....	160

Fig.		Page
44	Cart Used Near Boston for Collecting Vegetables.....	165
45-49	Packages Used for Vegetables	169, 171
50	Long Island Home Hamper.....	172
51	Bunching Onions in the Field.....	175
52	Philadelphia Market Wagon.....	177
53	Philadelphia Market Wagon Partly Loaded with Boxes.....	178
54	Long Island Market Wagon.....	179
55	Retail Wagon	180
56	Auto Delivery Truck	181
57	Motor Delivery Boat	183
58	Asparagus Bunched for Market.....	222
59	Beans Intercropped with Strawberries.....	234
60	Wire Trellis for Beans.....	239
61	Picking String Beans at Norfolk, Virginia.....	241
62	Bean Anthracnose	244
63	Field of Garden Beets.....	245
64	Beets Bunched for Market.....	251
65	Brussels Sprouts	253
66	A Field of Jersey Wakefield Cabbage.....	256
67	Two Strains of Danish Ball Head Cabbage.....	260
68	Volga Cabbage on Limestone Soil.....	262
69	Cabbage House	276
70	Cabbage House, Showing Wall Construction.....	277
71	Cabbage House, Showing Bin Construction.....	278
72	Club Root of Cabbage	286
73	Preparing Carrots for Market	294
74	Long Island Field of Cauliflower.....	296
75	Cauliflower Packed for Market.....	301
76	Irrigated Field of Celery.....	315
77	Celery Hiller	316
78	Celery Blanched with Boards.....	318
79	Celery Bunched for Market.....	320
80	Celery Storage House	323
81	Two Forms of Swiss Chard.....	326
82	Power Sprayer for Cucurbits.....	337
83	Leek	350
84	Cos Lettuce	352
85	Cos and Head Lettuce.....	357
86	Martynia	359
87	Ideal Netting on Netted Gem Muskmelon.....	365
88	Starting Muskmelons in Frames.....	368
89	Muskmelons Packed in Climax Baskets.....	375
90	Onion Plants Cut Back Preparatory to Transplanting.....	392
91	Onions Packed in Bermuda Crate.....	393
92	Field of Onions on Long Island.....	395
93	Field of Onions at Harvest	396
94	Onion Storage House.....	398
95	Onions Stored in Crates.....	399
96	Mild-Fruited Pepper	415

Fig.		Page
97	Radishes Bunched for Market.....	418
98	A Field of Rhubarb	420
99	Boston Marrow Squash	427
100	Some of the Commercial Types of Sweet Potatoes.....	436
101	Frame for Growing Sweet Potato Plants.....	441
102	Cross-Section of Pipe-Heated Frame	443
103	Sweet Potato Sets or Drawings	446
104	Plows for Harvesting Sweet Potatoes.....	447
105	Harvesting Thyme	449
106	Pot-Grown Tomato Plant	456
107	Tomatoes Packed for Market	464
108-110	Student Gardens at the Pennsylvania State College	499, 501, 503

CHAPTER I

A GENERAL VIEW

1. **Vegetable gardening**, or olericulture, is the art of growing the crops which are commonly known as vegetables. The term "vegetable" is usually applied to the edible parts of herbaceous plants. With some fruits, botanically so considered, as watermelon, muskmelon, tomato and eggplant, the parts used as food are commonly called vegetables. While fruits are extensively employed for dessert without cooking, heat must be applied to most vegetables before they become palatable; notable exceptions are tomato, celery, onion, lettuce and melons. Vegetables of great commercial importance are asparagus, bean, beet, cabbage, carrot, cauliflower, cucumber, horse-radish, parsnip, pea, pepper, sweet corn, sweet potato, radish, spinach, squash and turnip. The potato is also a vegetable, but it is generally regarded as a field crop, and it is often included in rotations with grass and cereals.

2. **Market gardening**, in its broadest sense, is the growing of vegetables for commercial purposes, but the generally accepted meaning is that market gardening relates to the intensive culture of crops that may be planted close together, that mature quickly and that offer great financial possibilities for the area cultivated. The most popular crops in market gardening are beets, onions, celery, lettuce, radishes, carrots and other vegetables which are usually cultivated with wheel hoes. Market gardens are generally located near cities, which provide good local markets. Land so situated is usually of high value and it is necessary for the grower to secure maximum returns from every square foot of ground.

3. **Trucking or farm gardening.**—There is no sharp line of demarcation between market gardening and trucking or farm gardening. According to common usage trucking means the growing of vegetables on an extensive field scale. The operations may be near enough to market to transport the products by wagon, or removed hundreds of miles, in which case trains or boats are used in transportation. The land is seldom worth more than \$300 an acre and usually much less. Such crops as cabbage, tomato, celery, sweet potato, sweet corn and other vegetables are grown and cultivated with horse implements. In some important trucking regions, as at Norfolk, Va., wheel hoe crops, including spinach and kale, are largely grown and shipped to market. Both market gardening and truck farming are often seen on the same farm. In some regions the farm gardening or trucking operations are restricted mainly to one or two crops; for example, the growing of late cabbage in western New York; tomatoes in Caroline county, Md.; celery and lettuce in Tioga county, Pa.; muskmelons at Rockyford, Col.; and sweet potatoes in certain sections of New Jersey.

4. **Vegetable forcing** is a very important branch of vegetable gardening. Hundreds of acres under glass in the United States are devoted to the growing of lettuce, tomatoes, cucumbers, radishes and other vegetables. This is the most intensive type of vegetable gardening. It is often combined with market gardening, the glass being a great advantage in starting many early crops. Greenhouses, hotbeds and cold frames employed for forcing purposes.

5. **Home vegetable gardening.**—The production of vegetables in the home garden for the home table is often called kitchen gardening. On most farms the area devoted to this purpose is known as "the garden." Other parts of the premises may be manured sparingly or not at all, while this small area receives heavy annual appli-

cations. It is an intensive type of gardening of greater importance than is generally appreciated.

6. Ideals.—In the production of vegetables for the home table the gardener should aim to secure (1) a variety of products, (2) the highest quality and (3) a supply as uniform and constant as possible at different seasons of the year.

In commercial gardening the following points must be considered: (1) **Quality.** Markets are becoming more discriminating every year. Consumers are urgent in their demands for quality, and it is important for growers to realize that prices and profits are largely dependent upon quality. This is especially true when vegetables are placed upon large city markets in competition with shipments from all parts of the country. The best quality is secured by the selection of proper varieties and the furnishing of ideal cultural conditions. Quick maturity is usually favorable to the best quality. This is especially true of the most succulent vegetables, as radish, turnip, beet, onion, lettuce, cabbage, celery and spinach. Vegetables of the finest edible quality are generally grown in moist, fertile soils, physically adapted to each class. (2) **Yields.** Large yields are essential to maximum profits. Some varieties of high quality are not good yielders. The grower is fortunate if quality and quantity can be secured in the same variety. There are many examples of quality being sacrificed for quantity by the selection of varieties of high yielding power. In producing vegetables for local markets that are not very discriminating this course may be justifiable, although it doubtless limits consumption. Whatever the variety, the commercial grower should endeavor to secure maximum yields at minimum outlay. The net returns from a given area of land should determine the extent to which methods can be intensified. If cheap land is available it may be more profitable and less difficult to follow ex-

tensive rather than intensive methods. (3) Earliness. The early production of crops is an important factor, first, because it generally enables the grower to sell at higher prices, and with reduced effort; second, it gives the gardener a lead on the market, always a great advantage in seasons of abundant crops; third, it makes possible the clearing of the land in time for succeeding cash crops or soil-improving crops. (4) Kind of market. It is important to have definite ideas concerning the disposition of a crop before it is started. Will it be sold on a general, open market in competition with the same vegetable from other sections, or will a special market be supplied? Market possibilities should always be studied before deciding upon crops and cropping plans.

7. Profits.—The profits in vegetable gardening are quite variable. In some instances they are so large that people are loath to believe the accounts, while in others the net returns are trifling. Considerable glass is used on places making the highest financial showing. At Cleveland, O., for example, a grower has been netting \$10,000 a year on 12 acres, but the reader should know that about $2\frac{3}{4}$ acres of this ground is covered with greenhouses in which are grown lettuce, tomatoes and cucumbers. The early vegetable plants are also started in these houses. The owner of this little farm is a master in everything that counts for success. Most growers, however, must be satisfied with much smaller returns. Peter Henderson regarded \$200 an acre a fairly satisfactory profit in market gardening, while he frequently procured much larger returns. There are records of single acres yielding from \$1,000 to \$2,000, at least one-half of which sums should be net profits. It is hoped that these statements will not be misleading, for the best growers sometimes have very little profit from a season's work. In truck farming the profits range from a few dollars to several hundred dollars an acre. A great deal

depends upon market and seasonal conditions. Commercial vegetable gardening is very generally regarded as one of the most profitable branches of horticulture, but success and failure depend more upon the ability of the man than upon any other factor.

8. The outlook.—Prices fluctuate greatly from year to year. In a season of low prices producers are likely to conclude that the vegetable business is being overdone. The next year, perhaps, prices are higher, the growers prosper, and increased areas are planted the following year. Prices for the past 10 years probably averaged as high as for the previous decade. This would not hold in all sections, but population is increasing rapidly and more vegetables will be required to meet future demands. Again, meat products will doubtless continue to bring higher and higher prices, and thus increase the demand for vegetables. Then, too, there is a growing sentiment for the use of more vegetables as well as more fruits, and this tendency will be for the benefit of commercial gardeners.

The large city markets are often crowded with a surplus of certain vegetables, but strictly high-grade products nearly always command good prices. The need of our cities is not more vegetables but better vegetables. When the problems of distribution and other questions concerning the marketing of produce have been satisfactorily solved, vegetable growers will be able to operate to better advantage and with greater surety.

Many important local markets are poorly supplied. In some sections little attention is given to grading and attractive marketing, and the offerings of locally grown vegetables are light during most of the year. Under such conditions wide awake growers should succeed. The production of special crops, as celery, onions, lettuce and cabbage, on a large scale, should not be undertaken without full assurance that soil, climate, labor, transportation and market conditions are favorable.

9. **Capital required.**—The capital required to the acre to equip and operate a vegetable garden or a farm depends upon the following factors: (1) The size of the farm. Small places require relatively more capital than larger ones. (2) The amount of glass desired. (3) The type of gardening to be followed. Market gardening requires much more capital to the acre than truck farming, and general truck farming requires more capital than special farming, as the growing of celery, onions, tomatoes and cabbage. The more intensive the business, the greater the capital needed. (4) The fertility of the land. Impoverished land requires heavy expenditures for manure and fertilizers to secure satisfactory crops. (5) Distance from market if produce is to be transported by wagon.

The estimates of capital required range from \$20 to \$500 an acre. Bailey states that the average in various sections is as follows: Florida, \$95; Texas, \$45; Illinois, \$70; Norfolk, Va., \$75 to \$125; east end of Long Island, \$75; west end of Long Island, \$150; 10 miles out of Philadelphia, \$200 to \$300 an acre. Peter Henderson suggests \$300 an acre for a 10-acre place, while Rawson claims that \$500 an acre is not too great an expenditure for a 10-acre place under intensive cultivation. The reader should bear in mind that Rawson has always used a large amount of glass. To start on as comprehensive a scale as the gardener referred to at Cleveland, O., (7) would require much more capital an acre than the largest sum mentioned.

These figures should not be discouraging to beginners of limited means. It is possible to start on a few acres and succeed with very little capital. Progress is much slower, however, under such conditions, but it is better than to borrow money and to make heavy investments without certainty of financial success. Anyone who knows the value of horses, tools, wagons, sash, manure

and fertilizers, as well as the cost of labor, must realize that considerable capital must be available before engaging in the business on even a fairly large scale.

10. Labor problems.—Vegetable growers sometimes think their hours are longer and their hardships greater than those of any other class of husbandmen. It is true that they often work 12 or more hours a day and that they are sometimes exposed to unpleasant weather, but it is also true that there is usually good compensation for the long hours and the hardships, if they can be called hardships. Commercial gardeners, unless they use considerable glass, are practically free to rest on Sunday, while this cannot be said of men following some other lines of farming. With skillful management the gardener should get a profit on every hour of labor. Then, why should he not observe the same hours a day as other classes of producers, hiring extra help when necessary and paying for all service rendered in excess of 10 hours a day? The best service cannot be expected for more than 10 hours, and for this reason longer days should be avoided as much as possible and additional men employed to do the work required. Marketing by wagon often requires early rising and sometimes late retiring and salesmen should be well compensated for this work.

The number of men to the acre is determined by (1) type of gardening, (2) tools available and (3) method of marketing. In the most intensive market gardening one man to the acre can be profitably employed. An eight-acre market garden on Long Island gives steady employment during the entire season to 13 men. In truck gardening one man may be able to care for 3 to 15 acres, depending upon the kinds of vegetables grown and system of cropping.

It is always an advantage to plan the work so that a good proportion of the men will be needed the year

round. This makes it possible to train the men so that their services will become more valuable every year.

The question of caring for the men demands careful consideration. There is perhaps no better plan than to provide neat, comfortable tenant houses. A highly successful Long Island market gardener, cultivating 80 acres in an intensive manner, gives 40 men employment through the summer. They are Poles and all of them are cared for in neat cottages. That is, perhaps a group of 10 men sleep and have their living quarters in an inexpensive but attractive house and the several groups meet for their meals at a boarding house operated by the owner of the farm. Prizes are offered to the groups of men for the best kept house and dooryard. The men are contented and come back from New York and Boston year after year for the planting and marketing seasons. Quite a number are retained the year round. The owner is very much pleased with the system.

A New Jersey trucker and fruit grower, operating on a very large scale, provides inexpensive summer houses for Italian laborers. Entire families from Philadelphia spend the summer in this manner, all the members who are old enough taking an active part in the farm work and in harvesting and preparing the crops for market. They are glad to get out of the hot, crowded city for what they regard as a pleasant summer outing. The whole scheme may be regarded as a fresh-air movement of the highest type. The able-bodied men perform the heavier work, while old men, women and children harvest and prepare most of the crops for market, and do all sorts of lighter work, mainly by the piece. With such a plan the earning power of a family is much greater than in the city, to say nothing of the benefits derived from living in the country.

In the South, colored laborers are used almost exclusively. Regarding the negro's efficiency, Oemler says he

is the best for many reasons. New Jersey truckers are well pleased with Italian labor. At Moorestown, Italians are used almost entirely in the picking of strawberries. Poles and other classes of foreigners are hired extensively on Long Island, and large numbers of Italians are employed in the market gardens around Boston. On many farms a certain number of steady Americans are kept the year round for teamsters and salesmen and to look after work requiring some experience.

It is always better to furnish employment for the entire year if this can be done. It enables the gardener to secure a better class of men. The day laborer does not usually take the interest or assume the responsibility that may be expected of a regular employee. For transitory laborers, piecework is preferred on many farms. This system is especially adapted to the harvesting and preparation of crops for market. If prices are properly adjusted it is absolutely fair to both employer and employee and relieves the gardener of much annoyance. At Norfolk, Va., potatoes are cut preparatory to planting for 20 to 25 cents a barrel, and picked when dug for 10 cents a barrel. Children and old men are sometimes paid 5 cents a glass for picking potato beetles.

The market garden referred to (paragraphs 7 and 9) at Cleveland, O., is operated on the profit-sharing basis. The system was modeled after a plan used by a great manufacturing concern. Liberal salaries are paid to men employed by the year. The salesman receives \$75 a month; greenhouse and field foremen \$50 and trustworthy laborers \$2 a day. The salary of each regular man stands as so much capital invested in the business. If the salary is \$50 a month the investment amounts to \$600. Dividends are declared semi-annually. On this unusually successful farm the profits often amount to 20 or even 30 per cent. It can be readily seen that the men get quite an appreciable income beyond their salaries. Again, the

Cleveland gardener stands ready to invest the savings of his men in the extension of his greenhouses and gardening operations. Several of them have taken advantage of the offer and in some instances the combined income of salary and dividends exceeds the profits of successful independent growers. All who have visited this establishment have been impressed with the satisfactory appearance of the crops and everything about the premises. The question naturally arises, What influence has this plan upon the quality of the services rendered? Suffice it to say that the system and the principles involved are certainly worth the consideration of every commercial gardener.

CHAPTER II

SELECTION OF LOCATION

11. **Markets.**—The most important factor to consider in the selection of a location for a general line of trucking or market gardening is the opportunity to dispose of the produce in a satisfactory manner. The large cities, as New York, Philadelphia, Boston and Chicago, consume enormous quantities of vegetables. It is a satisfaction to operate near such large centers of population, knowing that sale may be found for an almost unlimited supply of produce. The prospective gardener should realize, however, that competition is the keenest in these cities and that prices are often very low. It is also true that such markets offer special inducements for the growing of strictly high-grade vegetables. Prices are the most uniform and demands are the most constant in cities ranging in population from 25,000 to 300,000. The smaller cities are not so subject to the ruinous market gluts that occur in the large cities.

It is highly desirable to be near a good market. The grower is thus enabled to keep in close touch with the market and his patrons, and to deliver several loads in a day, at minimum expense and with the least effort. Moreover, the vegetables are perfectly fresh when they arrive, thus increasing the possibility of getting the best prices. When products from different sources are offered at the same time, local growers always have the advantage over shippers.

Many towns and small cities in all parts of the country furnish important outlets for vegetables. The smaller markets are not so discriminating and yet high quality is appreciated and helps to secure remunerative prices.

Summer resort regions require large quantities of fresh vegetables and the prices in such sections are nearly always satisfactory.

12. Soil is second in importance to market. A gardener is more likely to succeed with a poor soil and a good market than with a good soil and poor market. Favorable soil conditions, though, are exceedingly important and should be carefully considered in selecting a location. The sandy loams, with porous subsoils insuring thorough drainage, are undoubtedly the most valuable for a general line of cropping. Proper physical composition is of greater importance than the chemical character, for it is a simple matter to apply the required amounts of plant food, while it is expensive, if not impracticable, to make radical changes in the physical properties. Practically all good agricultural soils will, with proper treatment, produce fair crops of most classes of vegetables.

13. Climate.—Immense areas are planted in truck crops in various parts of the South because of favorable climatic conditions. The earlier season makes it possible to produce vegetables and place them on northern markets before local supplies arrive in large quantities. Yields southward are not usually larger, although it may be possible to remove more crops from the same area in a season. Long and warm seasons are also favorable to soil improvement. In many parts of the South it is easily possible to harvest two or even three cash crops in ample time to start a soil improvement crop. Cowpeas can often be worked into the rotation at midsummer, while such a course would be impossible in northern sections. These climatic advantages have made the South famous for its extensive trucking enterprises.

The cooler sections of the North also have their advantages. Insect and fungous pests are less troublesome than in the South. There is not so much leaching of sol-

uble plant foods from the soil during the winter and the cooler weather is favorable to the culture of certain crops, as potato, cabbage, celery, pea and onion.

Large bodies of water often make climatic conditions favorable for vegetable gardening. The success of cauliflower on Long Island is largely attributable to cool breezes from the sea. The winter season at Norfolk is shortened and made milder by the Gulf Stream. In lake districts there is much less damage from frosts in late spring and early fall than in similar latitudes where water influence is lacking. A Canadian tomato grower who plants near Lake Ontario has ripe tomatoes as soon as expert growers at high altitudes in Pennsylvania.

14. Water supply.—A cheap and abundant supply of pure water should be carefully considered before deciding upon a location. An immense quantity of water is needed to meet the needs of frame and greenhouse crops, to clean the vegetables for market and to supply the stock that may be kept. The value of irrigation in all sections is becoming more fully realized every year. Many gardeners have installed the most approved systems and are therefore making competition more severe for those who do not enjoy these advantages.

15. Contour of land.—Good air drainage is important during frosty nights. Gentle slopes secure such drainage and are also likely to have good soil drainage. Steep hills should be avoided, because they increase the cost of production and harvesting and are subject to erosion and are usually not retentive of soil moisture. It is almost impossible to grow good crops of onions, celery, beets and many other small vegetables upon steep hillsides. Level lands or gentle slopes are nearly always used by gardeners who follow intensive methods.

16. Aspect.—Southern or southeastern exposures are preferred for all types of vegetable gardening. The fuel bill is lighter in greenhouse work and the outdoor crops

are earlier. A sunny slope dries off and warms up earlier in the spring and makes planting possible sooner than on ground sloping to the north. Winds are not so severe on southern slopes. This point is well worth considering, for there will be less breakage of sash, crops will not be whipped and injured so much by the wind and less soil moisture will be lost by evaporation. In addition to these advantages it is more pleasant to live and to work on southern slopes.

17. Windbreaks.—Every experienced fruit grower knows the advantages of windbreaks. At Norfolk, Va., windbreaks of trees are extensively planted. They are especially valuable in the protection of field cucumbers; the young plants advance much more rapidly where such windbreaks have been established than on unprotected land. A common practice is to construct board windbreaks to shelter hotbeds and cold frames, although hedges are more attractive and more economical to establish. Natural windbreaks of trees or hills are most desirable of all.

18. Roads.—No greater mistake can be made than to locate on a poor road. Good roads more than double the value of land for gardening purposes. Mud, ruts, stones and steep hills are enough to discourage the most plucky gardener; they greatly increase the cost of marketing; reduce the amount of produce that can be hauled to market by the teams and wagons at command; cause constant annoyance to team and teamster and make it difficult to deliver vegetables at the market or the railroad station in first-class condition. A hard, smooth, well-drained and comparatively level road makes marketing a pleasure instead of a burden. Larger wagons may be used with less wear and tear, the trips will consume less time and hence the teams will be available for more work on the farm, than where poor roads must be used.

19. Shipping facilities.—Before engaging in trucking

at remote distances from market, shipping facilities should be carefully studied. Two or more lines of transportation are better than one. There should be assurance that boats or cars will be available when wanted. Freight and express rates should be reasonable and it should be possible to reach the great centers of consumption without delay. Facilities to ice cars should also be considered. It should be possible for boats or cars to be loaded during the day and then moved as rapidly as possible until the market is reached.

20. **Methods of selling** should also be taken into account. Some systems are greatly superior to others. If supplying a local market, the gardener is saved much annoyance as well as time by placing his wagon at a wholesale market where grocers and hucksters gather daily to secure their supplies. This is much better than driving from store to store to make sales. If delivering at a railroad siding it is a great advantage to be able to sell directly to the buyers representing city houses rather than to make consignments on commission. Selling at the track is becoming a popular method in many parts of the country. To get the benefits of this system, it is necessary, of course, to locate where there is sufficient production of vegetables to attract buyers.

21. **Price of land** is a secondary consideration in the selection of a vegetable farm. The interest and taxes on an additional investment of \$100 an acre are small matters when the land is near a first-class market and adapted to the line of cropping to be followed, and the expense saved in hauling produce, manure and supplies will soon more than overbalance the additional interest or rental.

22. **Labor supply.**—If cottages are provided for the workmen it is not necessary to be near the city, although close proximity is always an advantage in securing help. Practically all market gardeners near the large cities de-

pend upon day laborers who live near the farm or who travel to and from their homes by trolley. It has been observed that gardeners living some distance from the cities do not have much trouble in retaining their men.

23. Manure supply.—Intensive gardening requires manure in large amounts and the cities are the only sources of liberal supplies. A great many growers have it shipped, and in some instances it is transported hundreds of miles. For example, a grower on the eastern shore of Maryland gets manure from New York and Philadelphia, costing \$2.90 to \$3 a ton delivered on the railway siding. Some growers in close proximity to the cities secure manure at nominal charges. When manure is cheap and the haul short it is a simple matter to make the soil very fertile and to grow large crops of the best quality.

24. General remarks.—It often occurs that farmers, fruit growers, or poultrymen desire to increase their profits by growing vegetables. Perhaps not one condition is entirely favorable for the enterprise and yet it may be possible for them to enlarge their incomes by devoting part of the farm to gardening. This is doubtless the situation on thousands of farms. Under such conditions a modest start should be made, followed by larger plantings from year to year if returns justify extension.

CHAPTER III

SOILS

25. Classification of soils.—The Bureau of Soils of the United States Department of Agriculture has established a system of soil classification which should be familiar to every student of vegetable gardening.

26. Soil type.—The unit of classification is known as a type. Soil Survey Field Book, 1906, p. 16: "In the determination of a type of soil there are many factors to be considered. Among the most important are the texture, which deals with the size of the particles; the structure, which deals with the arrangement; the organic matter-content, origin, color, depth, drainage, topography, native vegetation and natural productivity. This classification is based primarily upon the physical properties, but all factors that influence the relation of soils to crops, so far as their influence can be determined, are taken into consideration."

27. Soil class.—Ibid., p. 16: "Soil types which constitute the units of soil classification, may be grouped in different ways. As soils are made up of particles of different sizes, they may be grouped according to the relative proportions of the particles of different sizes which they contain. This grouping is known as the soil class and is based on texture. By means of mechanical analyses the particles less than two millimeters in diameter are separated into seven grades, and the various percentage relationships of the different grades determine the class of soil; that is, they determine whether it is sand, sandy loam, loam, clay or some intermediate class. In addition to the fine earth, of which a mechanical analysis is made, many soils contain larger particles,

which if small are called 'gravel,' and if of larger size are called 'stones,' so that in the soil classification it is possible to have a gravelly sand, loam, or clay, and likewise stony members of the various classes." The table on the opposite page (*ibid.*, p. 17) will give the reader a better knowledge of soil classification:

SCHEME OF SOIL CLASSIFICATION

Class	1 Fine gravel 2-1 mm.	2 Coarse sand 1-0.5 mm.	3 Medium sand 0.5-0.25 mm.	4 Fine sand 0.25-0.1 mm.	5 Very fine sand 0.1-0.05 mm.	6 Silt 0.05-0.005 mm.	7 Clay 0.005-0 mm.
Coarse sand	More than 25% of 1 + 2 More than 50% of 1 + 2 + 3					0-15 Less than 20% of 6 + 7	0-10
Medium sand	Less than 25% of 1 + 2 More than 20% of 1 + 2 + 3					0-15 Less than 20% of 6 + 7	0-10
Fine sand	Less than 20% of 1 + 2 + 3					0-15 Less than 20% of 6 + 7	0-10
Sandy loam	More than 20% of 1 + 2 + 3					10-35 More than 20% and less than 50% of 6 + 7	5-15
Fine sandy loam	Less than 20% of 1 + 2 + 3					10-35 More than 20% and less than 50% of 6 + 7	5-15
Loam						15-25 Less than 55% of 6 More than 50% of 6 + 7	
Silt loam						More than 55% Less than of 6 25% of 7	
Clay loam						25-55 25-35 More than 60% of 6 + 7	
Sandy clay						Less than than 20% 25% of 6 of 7 Less than 60% of 6 + 7	
Silt clay						More than 55% 25-35% of 6 of 7	
Clay						More than 35% of 7 More than 60% of 6 + 7	

28. Soil series.—"It has been found that in many parts of the United States the soil classes of a given set are so evidently related through source of material, method of formation, topographic position, and coloration that the different types constitute merely a gradation in the texture of an otherwise uniform material. Soils of different classes that are thus related constitute a series. A complete soil series consists of material similar in many other characteristics, but grading in texture from stones and gravel on the one hand, through the sands and loams, to a heavy clay on the other." *Ibid.*, p. 19.

29. Atlantic and gulf coastal plains.—This soil province includes all of Delaware and Florida and parts of Long Island, New Jersey, Maryland, Virginia, North Carolina, South Carolina, Georgia, Alabama, Mississippi, Louisiana and Texas, and the following soil series are important to vegetable growers: Bastrop, Crockett, Laredo, Lufkin, Norfolk, Orangeburg, Portsmouth, Sassafras, Susquehanna and Webb. Of the miscellaneous trucking soils of this province the following may be mentioned: Collington sandy loam, Hempstead loam and muck and peat.

30. Bastrop series.—In Texas, 58,432 acres. (United States Bureau of Soils, *Bul.* 55, p. 97.) Melons and potatoes do well on the silt loams. The fine sandy loams are exceptionally well adapted to melons, potatoes, peanuts and vegetables when irrigated.

31. Crockett series.—In Texas, 29,504 acres. The gravelly loam is well adapted to early vegetables.

32. Laredo series.—In Texas, 55,040 acres. *Ibid.*, p. 101: "Laredo silty clay loam, mapped in the Brownsville area, Texas, is a very productive soil and well adapted to growing early vegetables. . . . Lettuce, melons, cauliflower, beets, peas, cabbage, onions, eggplant, cucumbers, tomatoes, carrots and both sweet and Irish potatoes are all profitably grown under irrigation. Cabbage is the principal crop and the average yield is about

18,000 pounds an acre. . . . The clay loam is well adapted to the growing of onions, giving an average yield of about 20,000 pounds an acre." Vegetables do well on other types of the Laredo series when irrigation is practiced.

33. Lufkin series.—In Texas, Mississippi, Alabama and Louisiana, 1,375,808 acres. Loam and sandy loam are adapted to potatoes, cucumbers and other vegetables.

34. Norfolk series.—In the Coastal Plain, 9,612,882 acres make the Norfolk series the most important trucking soil. It has a wide general distribution from Long Island to Texas. The fine sand is considered the leading soil for general trucking; 1,319,164 acres of this type have been surveyed. The Norfolk sand is an important soil because of its extreme earliness. It is especially valuable for the growing of radishes, spinach and other light crops for the early market. In North Carolina, asparagus is profitable on this soil and it produces excellent crops of early potatoes and lettuce in Virginia. The Norfolk sandy loam is largely planted in Irish and sweet potatoes and other heavy truck crops.

35. Orangeburg series.—From North Carolina to Texas, 3,486,464 acres of the Orangeburg series are distributed. The sandy types are well adapted to cabbage, kale, lettuce and the root crops. The heavier types are used for celery, onions and cabbage.

36. Sassafras series.—In Maryland, 407,344 acres. Tomatoes are extensively grown in loams and sandy loams, which are also well adapted to medium early truck. The sandy types are light, well-drained soils and well suited to peas, asparagus, Irish potatoes and other vegetables.

37. Susquehanna series.—In Texas, Louisiana, Alabama, Mississippi, North Carolina and Maryland, 1,495,990 acres. The fine sandy loam is well suited to truck crops.

38. **Webb series.**—In Texas, 184,512 acres. When the content of organic matter is large, the fine sandy loam is well adapted to growing Bermuda onions. Other vegetables have been grown to some extent.

39. **Collington sandy loam.**—Over 110,000 acres of this soil have been mapped in New Jersey and Maryland. It is one of the most productive soils of the trucking types.

40. **Hempstead loam.**—This soil is of interest to vegetable growers because it is used to a considerable extent on Long Island. It is regarded as a fair soil for late truck.

41. **Muck and peat.**—In Florida and Louisiana, 65,558 acres. After drainage, muck and peat are highly valued for the culture of celery, onions, peppermint and cabbage.

42. **River flood plains.**—United States Bureau of Soils, Bul. 55, p. 118: "An extensive and characteristic group of soils, usually known as 'bottom lands,' is found in the flood plains of numerous rivers and streams of the United States. The largest development of this group occurs along the Mississippi river, where the bottoms are often many miles in width." The most important series for trucking are Huntingdon, Miller, Wabash and Wheeling and the muck and peat soils.

43. **Huntingdon series.**—258,496 acres of the Huntingdon series are distributed. Through a dozen states, the loam and the gravelly loam are largely used in trucking.

44. **Wabash series** has 1,861,497 acres widely distributed. The loam can be used to advantage in growing canning crops, as sweet corn, tomatoes, peas and beans. The fine sandy loam is a good melon and potato soil and is also valued for other truck.

45. **Wheeling series.**—In Ohio and West Virginia, 20,032 acres. The gravelly loam has wide adaptation for truck crops. Melons and tomatoes are produced on the fine sand with marked results.

46. **Muck and peat.**—In Kentucky, Louisiana and

Nebraska, 24,640 acres. These soils are highly valued for the production of celery, onions, peppermint and cabbage.

47. Piedmont plateau.—This area lies between the Atlantic Coastal Plain and the Appalachian mountains and extends from the Hudson river to east-central Alabama. The land is gently rolling to hilly. The sand (259,744 acres in Georgia, North Carolina, South Carolina and Virginia) "is especially adapted to sweet potatoes and watermelons."

48. Appalachian mountains and plateau.—The loams, gravelly loam, sandy loam, and fine sandy loam of the DeKalb series are well adapted to vegetables. There are 760,266 acres of these types.

49. Limestone valleys and uplands.—Limestone soils are not generally regarded as good truck soils, although they often produce excellent results. Cantaloupes are grown on silt loam in the Highland river region of Tennessee. The fine sandy loam of the Cumberland series is adapted to vegetables. The silt loam of the Decatur series is especially well adapted to cantaloupes. A variety of late garden crops is grown successfully on the Hagerstown series.

50. Glacial and loessial regions.—U. S. Bureau of Soils, Bul. 55, p. 143: "North of a line passing through northern New Jersey, northwestern Pennsylvania, southwestward through Ohio to Cincinnati, crossing the Mississippi river at St. Louis, following the south side of the Missouri river into Montana, where it crosses the Canadian boundary line, then dips southward into Idaho as a long lobe in the mountainous nonagricultural region, and crosses the northwestern part of Washington, including the Puget Sound region," there are 8,057,686 acres of glacial and loessial soils.

51. Marshall series.—Of sand and fine sand, there are 107,008 acres. These types are well adapted to truck crops.

52. Miami series.—The sand and the fine sand are the best early truck soils of this section. The stony and gravelly sandy loams are fairly good truck soils.

53. Miscellaneous types.—The Custer silt loam produces profitable yields of beets, peas, cabbage and other vegetables. Lexington silt loam is suited to vegetables. Lynden fine sandy loam is well adapted to cabbage, cauliflower, carrots, garden peas, cucumbers and other vegetables. Madison loam does well when planted in cabbage, tomatoes and other truck crops. Portage sandy loam and Portage silt loam are regarded as valuable for vegetables. Rhinebeck loam produces good crops of cabbage. Whatcom silt loam produces profitable crops of peas and cabbage and other garden crops.

54. Glacial lake and river terraces.—U. S. Bureau of Soils, Bul. 55, p. 153: "Occurs in the glacial region, principally as terraces around lakes, or along streams or as deposits in areas which were formerly covered by water."

55. Clyde series.—When well drained, these soils are very productive. The loam is valued for cabbage and canning crops. The clay loam is extensively used for cabbage. "The fine sandy loam is a desirable truck soil and is admirably adapted to cabbage, tomatoes, peas, beans, cucumbers and potatoes." The gravelly sand and fine sand are suited to truck crops.

56. Dunkirk series.—The fine sand is valued for early crops. The gravelly loam gives large yields of beans and potatoes. There are large areas in New York and Ohio.

57. Muck and peat.—In this region, 532,842 acres. These soils are highly valued for the production of celery, onions, peppermint, cabbage and lettuce.

58. Pacific coast.—The sand and the fine sand of the Fresno series are valued for vegetables under irrigation. The Hanford series when well drained are good soils for vegetables. Truck crops do well on the sandy loam of the Maricopa series. The soils of the Oxnard series are

particularly well adapted to lima beans and the industry has been extensively developed on these soils. The Placencia series is used for beans and other vegetables. The fine sandy loam of the Sacramento series is valued for vegetables and the loam of this area is also used. The sandy types of the Salem series are good vegetable soils. When irrigated, the San Joaquin series are valuable trucking soils, and vegetables are grown to some extent on the Stockton series. There are 110,163 acres of muck and peat soils of the Pacific Coast valued for the crops usually grown on these lands. Puget clay soil and Puget fine sandy loam have deficient drainage, but when well drained and protected from overflowing, truck crops and potatoes are successfully grown. Puget silt loam gives promise of becoming a highly prized soil for small fruits and vegetables.

59. Soil texture.—It will be seen from a study of various soil types cited that the value of a soil for trucking purposes is determined largely by its texture. The value of a soil for very early truck depends mainly upon the amount and size of sand. That is, coarse sand is a "quick" soil, because it is well drained and dries out and consequently warms up very early in the spring, and makes early planting possible. Again, the coarse sands are warmer during the entire period of growth, thus hastening early maturity. Such soils require a large amount of vegetable matter. Liberal fertilizing and irrigation are usually a great advantage. The medium sands are not quite so early, but are more productive and somewhat more retentive of moisture and plant food. The fine sands are often our best trucking soils. Although not quite so early as the coarse and the medium sands, they are usually more productive. The silt and the clay soils are often valuable for late crops, and the maintenance of fertility is less expensive on the heavier types.

60. Advantages of sand.—The soils of the most impor-

tant trucking regions of the United States contain considerable sand. The advantages of sand in soils for vegetables may be enumerated as follows: (1) The land warms up earlier in the spring and maintains a higher temperature than heavy soils do; (2) fertilizers act more quickly; (3) tillage may begin earlier in the spring and continue later in the fall; (4) tillage is less expensive; (5) tillage may begin sooner after rains; (6) transplanting is facilitated; (7) the harvesting of many crops is facilitated; (8) soils do not become so hard and compact when harvesting crops, especially when the ground is wet; (9) sand lends itself to irrigation because the water is quickly absorbed; (10) the root crops are smoother, better formed and have fewer fibrous roots; (11) many crops require less work in cleaning and preparing for market.

61. Water content.—Other things being equal, the smaller the particles the greater is the absorptive power of the soil. Silty soils suffer less from drouth than sandy soils; hence it is more important to be prepared to irrigate the sandy types. The production of large crops of high quality requires a constant and abundant supply of moisture, and the ability to meet the needs of the growing crop determines the value of a soil to a great extent for trucking purposes. A well drained subsoil is important, and yet it should have strong capillary action. The depth of the water table is an important factor in relation to soil moisture. In small areas of trucking soils it is within a few feet of the surface and such soils are highly valued for gardening purposes.

62. Drainage.—Good drainage is essential to every garden crop. Some vegetables stand wet soils better than others, but no crop thrives in a water-logged soil. Good drainage is especially important for early truck, hence the value of the coarser sands to supply early markets. Artificial drainage is a profitable investment on many soils devoted to commercial gardening.

63. Chemical properties.—While it is necessary to have an adequate supply of available plant food, the physical composition of the soil is of much greater importance than the chemical. It is a simple matter to supply fertilizers, but practically impossible to make good truck soils out of some types. Manure or green crops may be used with the utmost freedom. Although these greatly improve the heavier types, they will not make ideal soils for garden crops. The proper chemical composition of truck soils, however, is important and this matter should receive the most careful consideration. See Chapter VII on the use of fertilizers.

64. Soil adaptation.—Soils differ greatly in their adaptation to various crops. Late cabbage, for example, succeeds on very heavy soils, while the lighter types produce good early cabbage. Lima beans do best on sandy soils, while field beans prefer the heavier types. These illustrations simply serve as examples. More definite information is given in Chapter XXI, which is devoted to the culture of various classes of vegetables.

CHAPTER IV

TILLAGE AND TILLAGE TOOLS

65. The object of tillage.—So far as soil management is concerned, tillage is the most important operation in vegetable gardening. Both yield and quality are largely determined by the character of the tillage operations. The objects of tillage are as follows: (1) To modify the physical conditions; (2) to regulate the soil moisture content; (3) to modify soil temperatures; (4) to aerate the soil; (5) to provide proper conditions for the action of friendly bacteria; (6) to destroy weeds; (7) to prevent surface erosion; (8) to cover humus-producing materials, as manure and green crops.

The value or efficiency of tillage depends upon character, thoroughness, and timeliness. Both the character and the thoroughness of tillage count for much in vegetable gardening, for in growing crops of high cash value gardeners should be certain that tillage operations should be of the right kind and be fully completed before work is discontinued. Timeliness is of primary importance, for to plow, harrow, cultivate, hoe and weed at just the right time may make the difference between profit and loss. Conditions may be satisfactory for plowing today, while rain tomorrow may fill the soil with too much moisture for the most effectual plowing, and so much rain may fall that plowing, harrowing and planting may be delayed a week or more. Such delays often result in reaching the market too late for the best prices. The failure to cultivate a field at the right time frequently results in the weeds taking possession, a situation causing unnecessary expense in hoeing and hand weeding, and in addition producing later maturing crops and reduced yields. There

is a proper time in vegetable gardening for every tillage operation and fortunate is the man who not only knows when to till but who usually does the work when most advantageous.

66. The value of tillage implements.—The increased price of land, labor and supplies makes it imperative for the gardener to use labor-saving implements, with which the work can usually be done better and cheaper than by any hand method. In the purchase of tools and implements for vegetable gardening, the following factors should be considered: (1) The efficiency of the tools and the adaptation to the work to be done; (2) the rapidity with which the work may be done; (3) the ease of operation to team and workmen; (4) durability; and (5) cost.

67. Plowing.—The walking mold-board plow is most commonly used among vegetable gardeners. Sulky gang and sulky disk plows are seldom used, but are becoming more popular.

Fall plowing is practiced extensively by vegetable growers. It is considered especially desirable on the heavier types of soils. The following advantages may be enumerated: (1) If the land is hilly or rolling, rough unbroken furrows will collect more water than when plowing is deferred until spring, and if harrowing is done as soon as possible, there will be a maximum supply of soil moisture to meet the needs of spring crops; (2) the physical composition of many soils is improved; (3) vegetable matter plowed down in the fall becomes better decayed and more valuable to the spring crop; (4) land plowed in the fall may be harrowed and therefore planted earlier in the spring; (5) some fall plowing often relieves the pressure of the spring work, and makes possible the starting of all crops earlier; (6) fall plowing exposes many insect enemies to destroying agencies and thus reduces ravages from this source. Fall plowing in the North, where the land is sealed by frost during the win-

ter is regarded as more desirable than in the South, where the loss from leaching must be considered. It is especially advantageous to plow heavy sod lands in the fall.

When plowing is deferred until spring it should be done at the earliest possible date. This is important from every standpoint. No greater mistake can be made, however, than to plow before the ground is dry enough. Every experienced farmer well knows the evil effects of such a practice. In order that the soil may be dried out early and that plowing may begin as soon as possible, many gardeners prefer not to spread stable manures until the ground is ready to plow, because such a mulch greatly retards the evaporation of soil moisture.

Most garden crops thrive best in soils which have been ameliorated to a considerable depth, so that deep plowing is favored by successful vegetable growers. No soil should be plowed deeper, however, than the character and depth of the top soil will permit. The intermingling of a large portion of unproductive subsoil is always detrimental to garden crops.

The subsoiling of garden soils has been advocated by many writers, but it is seldom practiced and is of doubtful utility.

68. Harrowing.—In making preparation for sowing or transplanting, harrowing follows plowing. The harrow is also used sometimes by truckers in cultivating after the crops have been started. When used in this manner it is often effective in providing the proper tilth and in destroying small weeds.

Spike-tooth harrows are used more generally than their efficiency justifies, for they are scarcely comparable to some other types in their pulverizing action; their teeth do not run to great depth, and their tendency is to push the clods aside rather than to break them. Smoothing harrows are most valuable, perhaps, when used as weeders after a crop like potatoes or sweet corn has been

started. The spring-tooth harrow is an important tool among gardeners, being especially well adapted to stony ground. It is also an excellent pulverizer and leveler. Disk and cutaway disk harrows are exceedingly valuable implements as pulverizers, and are especially useful for clay soils and for reducing heavy sods. When heavily weighted they cut to great depth. Disking is sometimes practiced before plowing. This preliminary operation is regarded by some as being of special value in truck farming. Manure can be applied, and then chopped up and worked into the soil before plowing. This method results in fine soil to the full depth of the plow furrow, if harrowing after plowing is done as thoroughly as it should be. The disk harrow is unquestionably the best pulverizing tool for the heavier soil types and is far superior to the spring-tooth harrow in most soils. The Acme harrow is prized by many vegetable growers because it not only pulverizes to a considerable depth, but it has also good leveling action. The Meeker smoothing harrow, which has 58 disks mounted on four rollers, is practically indispensable in vegetable gardening as a finishing harrow and should be used exclusively for this purpose. It does the work of a steel garden rake, though better and more economically, and not only pulverizes to the depth of 3 or 4 inches, crushing even the smallest clods, but by an adjustable plank running across the middle of the harrow it also levels and leaves the soil in the smoothest possible condition for sowing or transplanting. It is an old harrow, but not as generally used as it should be.

The efficiency of harrowing depends not only upon the adaptation of the implement to the work to be performed, but also upon the moisture content of the soil at the time of operation. If too dry, a large percentage of the clods will not be broken and if too wet great injury will be caused in puddling. Closer attention should be given this matter by all classes of cultivators. A common oc-

currence is to plow land and let it lie for many days without harrowing. Except for fall plowing no greater mistake can be made, for during the interval between plowing and harrowing an enormous amount of soil moisture escapes and thorough pulverization of the soil when dried is almost impossible. No more land should be plowed than can be harrowed at least once the same day.

69. **Dragging.**—Figure 1 shows a homemade device known in different sections as a plank drag, float, planker, clod crusher or slicker. It is valuable both as a pulver-

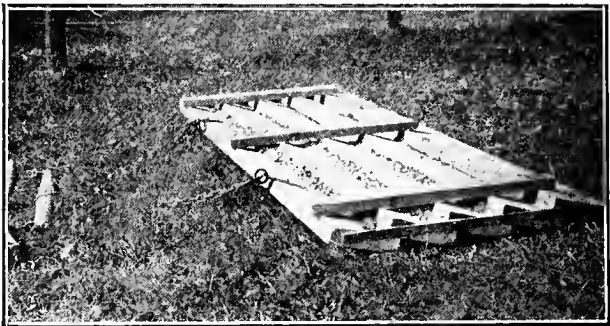

FIG. 1. PLANK DRAG

izer and a leveler. Drags differ greatly in size and style of construction. Whatever the form of construction the principles involved are the same. The drag is not so essential if the Meeker smoothing harrow is available, but in the absence of this tool it cannot be dispensed with. It is especially valuable in preparing a very fine, smooth surface for small seeds or delicate plants.

70. **Soil preparation.**—Inexperienced gardeners are often undecided as to the best order for tillage operations after plowing. Suppose that a heavy sod has been plowed and that the soil is a clay loam, what tools should be

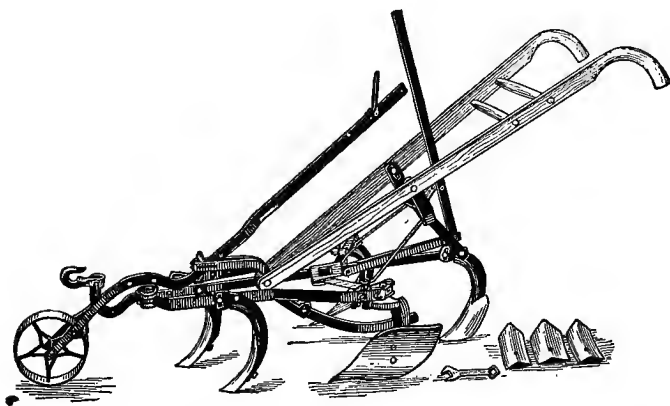
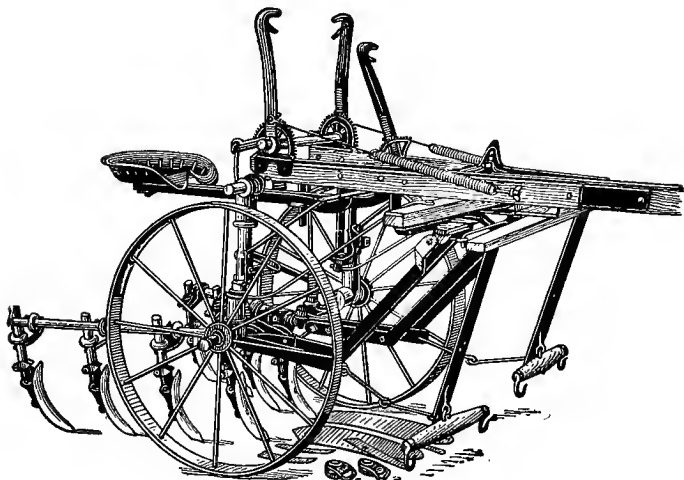

FIG. 2. DIFFERENT FORMS OF HORSE CULTIVATORS

used and what should be the order of their use to secure the best medium for sowing or transplanting? The following program should prove satisfactory: (1) Dragging with the furrows; (2) disking with the furrows; (3) disking across the furrows; (4) dragging across the disk marks; (5) disking again if necessary; (6) harrowing with the Meeker smoothing harrow until the soil is thoroughly pulverized and the surface even and smooth.

71. Cultivation.—All but one of the purposes of tillage are accomplished by cultivation. The efficiency of cultivation for any particular crop depends upon (1) the character of the tool used, (2) when it is used, (3) how skillfully it is used.

There are two general classes of cultivators, viz., horse-cultivators (Figure 2) and hand cultivators (Figure 3). Horse-cultivators may be provided with shovels, teeth, or rake attachments; they may be for one or more rows and operated when riding or walking. In working field garden crops, such as sweet corn, tomatoes and cabbage, two-horse riding cultivators are employed extensively, but with most crops planted far enough apart to permit of horse-tillage, the single horse cultivators are in general use. Spike-tooth and narrow shovels are the best conservers of soil moisture and leave the soil in the best physical condition, while the broader shovels are effective in destroying large weeds and in breaking up compacted soils. Hillers and shovels of various shapes may be purchased with most horse cultivators and attached whenever it will be advantageous.

Hand wheel cultivators are made in various styles (Figure 3). They should have rather high wheels with broad tires. Some wheel hoes are made to straddle the rows, others to go between them. Double wheel hoes are most serviceable and economical in smooth, level soil that is easily cultivated; the single wheel hoe is adapted to conditions not so favorable to tillage. Teeth, rakes,

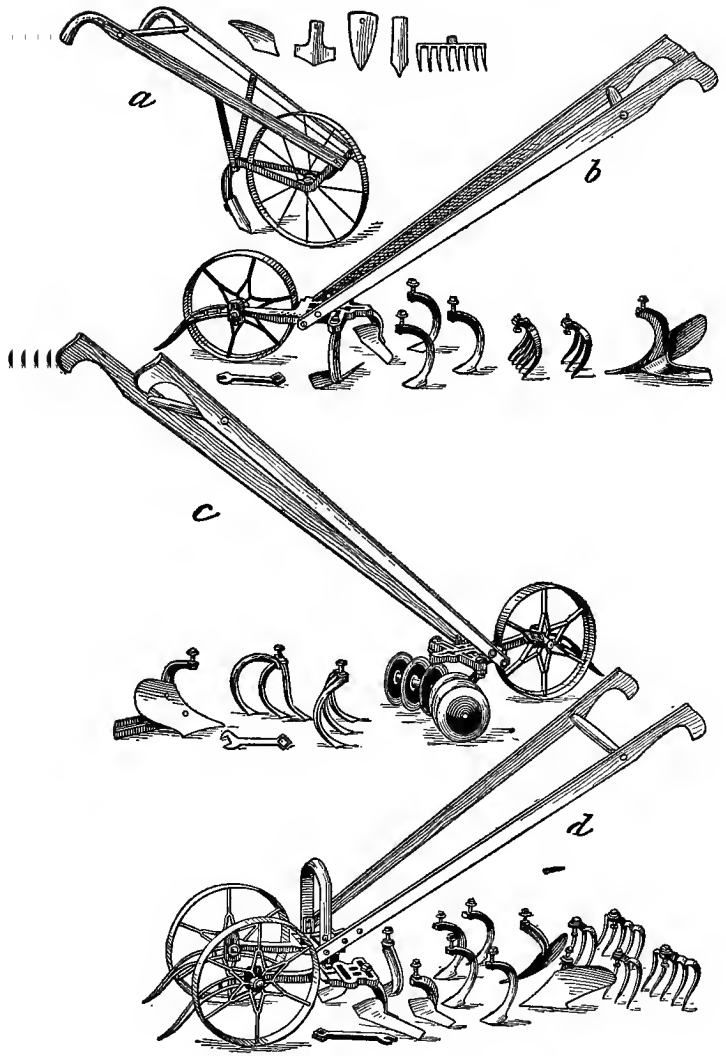

FIG. 3. DIFFERENT FORMS OF HAND CULTIVATORS

knives and shovels are made in great variety for most wheel hoes. The knives as shown in Figure 3 are especially valuable for shallow tillage in sandy soils. They may be shortened in order to cultivate when the rows are only 6 inches apart, although 10 to 14 inches are usually allowed for wheel hoe cultivation. Figure 4 shows a combination wheel hoe and seed drill that is highly val-

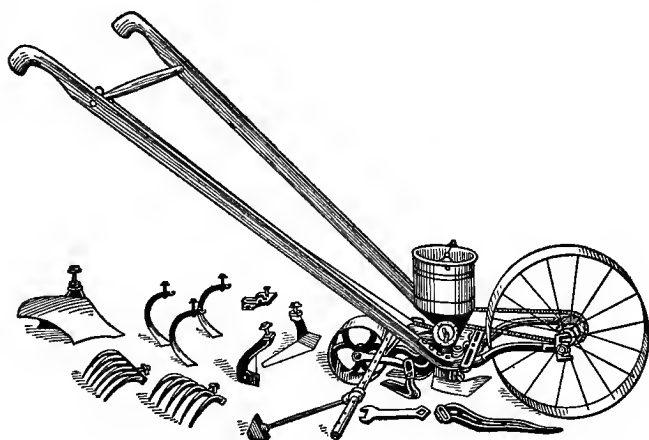

FIG. 4. COMBINATION HAND SEED DRILL AND CULTIVATOR

ued, but combination hoes and drills are not generally popular.

There is no rule to be followed in cultivating garden crops. Hard crusts should certainly not be allowed to remain unbroken for any great length of time. It is generally best to cultivate as soon as the ground is dry enough after every rain. Frequent tillage destroys weeds before they have made much of a start and it also maintains the best growing conditions in the soil. Crops are never injured by too much cultivation of the proper kind,

when the ground is not too wet and the plants are not so large as to make tillage impossible without physical injury.

Level tillage is unquestionably best except for special purposes. Hilling is sometimes justifiable, but the practice is far too general. The main excuse for the practice is that it serves to eradicate weeds when they have gotten very much of a start during wet weather.

Tillage should begin as soon as possible after sowing or transplanting by cultivating about $2\frac{1}{2}$ inches deep at first, decreasing the depth as the crop advances. The

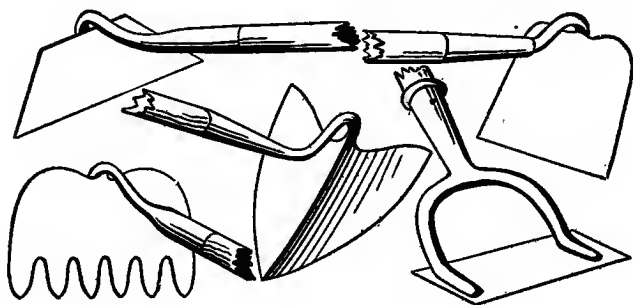

FIG. 5. DIFFERENT FORMS OF HAND HOES

importance of reducing the uncultivated row-strip to a minimum width is not fully appreciated by most growers. Workmen can usually get much closer to the rows than they think they can. Cultivators do better work than hand hoes and reduce the cost of tillage.

72. Hoeing.—As previously indicated (71), hand hoeing is never so efficient as cultivating with horse implements or wheel hoes. Unless crops are planted in check rows, some hand hoe work is necessary in growing nearly all crops. But even check rows do not always eliminate the use of hand hoes. The work should not be neglected

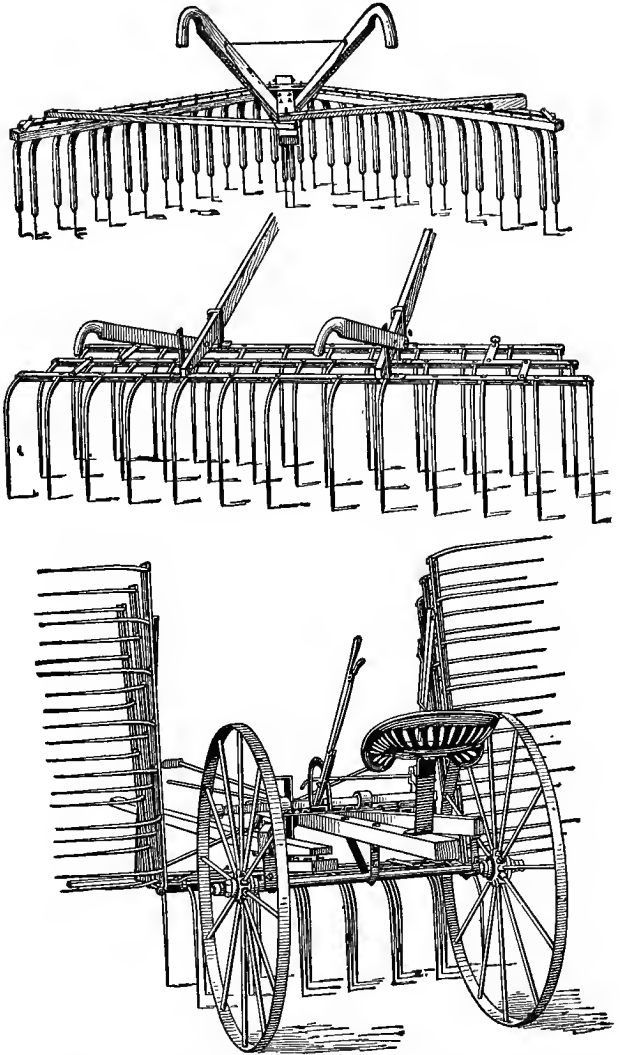

FIG. 6. DIFFERENT FORMS OF HORSE WEEDERS

until weeds get a start, for cultivation will then be much more tedious and expensive. If attended to before the weed seeds have fully germinated it will usually be effective. Figure 5 illustrates various types of hand hoes. The rake hoe is the best for light soils when used before the weeds have made a start, because it is an easy tool to use and leaves the surface in the best physical condition. The half-moon hoe is an excellent form to use where the plants are crowded. Square-bladed hilling hoes are popular. The narrow, two-pointed hoe is adapted to crops such as beets and onions planted close together in the row.

73. Weeding.—Weeders are divided into two classes,

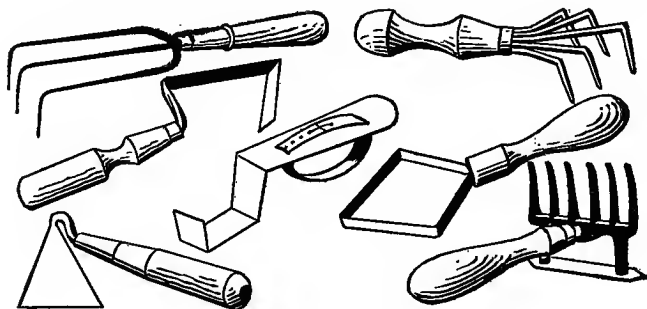

FIG. 7. DIFFERENT FORMS OF HAND WEEDERS

viz., horse weeders (Fig. 6), and hand weeders (Fig. 7). Horse weeders are useful in cultivating sweet corn, potatoes and a few other crops for a brief period after planting. They reduce the cost of tillage, especially if the soil is light and easily worked. Some hand weeding is necessary in growing beets, onions, carrots and many other closely planted crops. The tools shown in Figure 7 are very generally used. The Garrahan weeder is a homemade device of special value. It is easily made from

an old file and a piece of buggy spoke for a handle. The file is heated and then bent into the form of a hook. The blade may be sharpened by any convenient method, but can be very quickly done on an emery stone. This tool is useful in thinning as well as in weeding, since it saves much of the time required to pull every surplus plant.

74. Care of tools and implements.—Care largely determines the value and durability of tools and implements. All classes of farmers will do well to observe the following instructions: (1) Keep tools and implements under cover when not in use; (2) paint every year or two; (3) keep in good repair; (4) keep a wrench at hand when at work in the field, for all the parts must be tight; (5) clean the metal parts before storing; (6) some tools, as hoes, require frequent sharpening, so it is an advantage to keep a file in the field for this purpose; (7) a place for every tool when not in use saves time and prevents annoyance.

CHAPTER V

STABLE MANURES

75. **Extent used.**—Stable manures are universally regarded as the most valuable fertilizing materials for the growing of all classes of vegetables upon all types of soils. This is a very broad statement, but it is not likely to be challenged, since the most successful vegetable growers in all parts of the world place their main dependence upon stable manures. In many instances applications of special fertilizers have a more marked effect for the season or possibly for several seasons, but their long-continued use without additions of vegetable matter to the soil is always disastrous. It is true that examples can be cited of gardening operations that have been conducted for many years without any increase in the supply of vegetable matter, but in all such cases the supply of humus is very large to begin with. Muck soils are often farmed for a long term of years without manure, but even upon these soils stable manures are highly beneficial.

Market gardeners are especially dependent upon the use of stable manure, because there is no interval between crops for the growing of green manures. Near all our large cities immense quantities of manure are used by growers following intensive methods. In trucking or farm gardening, however, growers are learning to rely mainly upon cover crops and green manures, so the demand from this class of producers is not quite so great, perhaps, as a few years ago. But there are many instances of manure being shipped hundreds of miles. One very extensive grower on the eastern shore of Maryland declares that he could not be successful in producing

melons and cucumbers without stable manure shipped from Philadelphia and New York.

76. Manure as a source of humus.—Many growers of vegetables would never buy manure were it not for the necessity of maintaining the supply of soil humus. That is, it would be cheaper for thousands of gardeners to purchase commercial fertilizers for the needed plant foods than to buy bulky manure, pay freight and then haul several miles perhaps, not to mention the cost of spreading and of composting. But a liberal supply of soil humus is absolutely essential to success in growing all classes of vegetables. It increases the water-retaining capacity of soils; secures improved soil aeration; aids important chemical changes; increases soil temperature; helps to create favorable conditions for the work of friendly bacteria; improves the structure of soils; makes it possible to begin work earlier in the spring and reduces the labor of tillage. Stable manures are superior to green manures as humus-making materials because they decompose more rapidly and are, therefore, of greater value to the crops under cultivation.

77. Manure as a source of plant food.—In many instances manure is the cheapest source of plant food. Gardeners living near the cities often procure it at nominal prices. Under such conditions it would be unwise to make large expenditures for commercial fertilizers unless for special foods, such as nitrate of soda. Stable manures do not become available so quickly as many forms of commercial fertilizers, although composting (86) is of great value in hastening decomposition. The following table (U. S. Department of Agriculture, Farmers' Bulletin 192, page 9) shows the relative composition and the value of the manure of various animals:

ANALYSES AND VALUE OF A TON OF MANURE OF VARIOUS ANIMALS

	Water %	Nitrogen %	Phosphoric acid %	Potash %	Value a ton
Sheep	59.52	0.768	0.391	0.591	\$3.30
Calves	77.73	0.497	0.172	0.532	2.18
Hogs	74.13	0.840	0.390	0.320	3.29
Cows	75.25	0.426	0.290	0.440	2.02
Horses	48.69	0.490	0.260	0.480	2.21
Hens	56.00	0.80-2	0.50-2	0.80-0.90	7.07

The commercial values as expressed in the last column of the above table vary greatly. It is probably seldom that horse manure from city livery stables is worth as much as \$2 a ton for the actual supply of plant food.

78. Horse manure.—The bulk of manures purchased in the cities is horse manure. It is much drier than most other manures, looser in texture and acts more quickly than cow manure. It is practically the only kind of manure used in the making of hotbeds. Its decomposition in compost piles is very rapid and it must be carefully managed to prevent the loss of ammonia.

79. Cow manure.—Cow manure is highly valued by vegetable growers as a slow-acting manure. It is much slower in decomposition than horse manure and may be safely applied nearer the time of planting. Limited quantities can often be bought at reasonable prices in small towns.

80. Hog manure is also slow in action and generates very little heat in decomposing. It is valued by vegetable growers, although very small quantities are used. Some market gardeners near eastern cities have hogs fed mainly with the refuse from kitchens, and kept generally in cellars or covered sheds that are frequently very foul. Such practice is not to be commended from a sanitary point of view.

81. Sheep manure is a hot manure, and when suffi-

ciently moist decomposes very rapidly. Because of the fine texture, it is regarded as especially valuable for frame, greenhouse and open-ground crops that require a fine manure and a large amount of nitrogen. Onions are especially benefited by this manure.

82. Hen manure, of all the farm manures, is the most valuable for garden purposes. It contains a large percentage of potash and phosphoric acid and is especially rich in nitrogen. It has long been regarded the best fertilizer for onions as well as for all other garden crops requiring large amounts of nitrogen. The fine texture, when an absorbent has been used in sufficient quantity, makes it highly desirable for intensive systems of cropping.

At the Pennsylvania State College, manure was collected from May 1 till May 18 from the dropping boards under the roosts of 145 hens. During this period 75 pounds of 14 per cent available acid phosphate were scattered on the platforms daily to prevent the loss of nitrogen. The platforms were cleaned about twice a week. A barrel filled in 18 days contained 330 pounds of manure, including the acid phosphate. The manure was analyzed by the experiment station and found to contain 52.46 per cent of moisture, 1.85 per cent of nitrogen, 3.17 per cent of phosphoric acid and 0.31 per cent of potash. At the prices usually paid for fertilizers it was worth \$9 a ton. The 145 hens would produce a ton in 110 days. These figures of course do not take into account the amount of manure dropped in the litter and in the yards, but they do show that it is well worth while taking care of the poultry manure. The added acid phosphate prevents the escape of ammonia and increases the value of the manure, since a liberal amount of phosphoric acid is required by all garden crops. The greatest objection to this plan of handling poultry manure is that it is too wet to spread very satisfactorily, but this trouble can be

easily avoided by using sifted coal ashes, dry soil or other absorbents in addition to acid phosphate.

83. Cost of horse manure.—Prices paid for horse manure vary considerably. A Long Island market gardener is paid over \$400 a year to remove the manure daily (except Sunday) from a stable feeding a great many horses. Thus he secures hundreds of tons during the year. Many other Long Island gardeners pay from 25



FIG. 8. HAULING MANURE NEAR BOSTON

to 50 cents a load, the loads varying from two to four or more tons each. Boston market gardeners are charged from \$1 to \$1.50 a load of three to five tons. Cleveland growers pay 25 to 50 cents a load of two tons. Near Philadelphia market gardeners who haul it from the stables pay 25 to 50 cents a load of about two tons. When shipped 10 to 50 miles from Philadelphia the price delivered on the railroad sidings varies from \$1.85 to \$2.15 a ton. In New Jersey, prices are variable, but with freight charges the cost usually exceeds \$2. When de-

livery on barge is possible the rate is perhaps 25 per cent lower. A grower on the eastern shore of Maryland pays about \$3 a ton for New York or Philadelphia manure delivered at his farm siding. In most of the smaller cities and towns the price varies from 50 cents to \$1 a ton.

84. **Transportation of manures.**—Barges are used extensively to carry manure to ports near commercial gardening centers. This is the cheapest method of transportation unless the gardener operates near enough to the stables to haul the manure direct by wagon or sled. Im-



FIG. 9. HAULING MANURE NEAR PHILADELPHIA

mense quantities are shipped by train. The business in New York and Philadelphia is handled by firms who collect the manure regularly and store, if necessary, until orders are received. Considerable water is used in the care of the manure in storage to control fire-fanging. This is also a simple method of selling water by the ton!

The large, well-built wagons at Boston carry three to five tons. The one shown in Figure 8 cost \$300 and it is kept busy the year round supplying a large market garden. Heavy canvas is used to cover the loads in

hauling from the city to prevent the manure from being strewn along the streets and roads. Figure 9 shows a wagon typical of the ones used in Philadelphia County to haul manure from the railroad stations; it is loaded with four and one-half tons. In the smaller centers of production about two tons is the most common weight for a load. One-horse wagons carrying 1500 pounds or a ton are often used by market gardeners in making short hauls, and dump carts of about the same capacity are utilized to some extent.

85. Fresh manure versus rotten manure.—In general farming the best practice is to apply manure to the land as soon as possible after it is produced. This may also be the best policy in certain lines of vegetable farming; as, for example, grass land to be planted in early cabbage and early sweet corn might well receive dressings of fresh manures any time after hay harvest of the previous season. In field trucking a very general and commendable practice is to apply fresh manures at any time, provided all conditions are favorable to such applications. The probabilities are that yields will be better than if an attempt is made to store the manure and apply when well decomposed. It is a well-known fact, however, among market gardeners that fresh stable manures are not suitable for intensive operations in market gardening, because they are not quick enough in their action and their coarse texture prevents thorough incorporation with the soil particles. Again, fresh manures are likely to cause a rank growth of certain crops, such as tomato, eggplant, pepper, melon and cucumber, at the sacrifice of fruit. With root crops, like radish, turnip, beet, carrot, parsnip and salsify, fresh manures not only cause excessive top growth, but also prevent the proper root development. It is, therefore, generally conceded that rotten manure is indispensable in all intensive lines of vegetable gardening.

86. Composting manures.—On almost every place de-

voted to market gardening there is a compost pile. Although it is called the compost pile, it seldom contains much material in addition to horse manure. This does not have reference to the sod and general compost heaps near most greenhouse establishments. The manure compost pile is essential because (1) manure is hauled the year round and the land is generally occupied with growing crops when it is impossible to apply directly to the soil; (2) fresh manure is too coarse to apply in large amounts immediately before planting, because it cannot be incorporated thoroughly with the soil; (3) fresh manure induces a rank growth of stem and leaf at the expense of a good crop; (4) composting destroys troublesome weed seeds.

Valuable data upon this subject have been published by the Maryland station. The results obtained show that (1) when manure is allowed to ferment in piles for six months no danger of distributing weed seeds is incurred; (2) when manure is allowed to remain in piles, undergoing partial fermentation, little danger of distribution is incurred.

Although composting is essential, it should be avoided as much as possible, for decomposition cannot be controlled without some loss of plant food. It also requires a large additional expenditure of labor in the extra handling.

In the management of compost heaps the gardener should see that leaching and fire-fanging are controlled and that the finest texture is secured. To accomplish these ends it is customary to stack in rather compact, flat piles not less than 4 feet deep, and covering as much area as may be necessary. The piles are so deep that there can be no leaching if they are built with perpendicular sides. They must be watered with a hose often and freely enough to prevent fire-fanging. To improve the texture, the piles are turned from one to three times at conven-

ient intervals. About six months are required to secure the proper decomposition. A manure shredder is used by some Boston gardeners. This powerful machine, operated by an engine, is placed alongside of the compost pile and the manure is shredded before applying in the field. The shredder is provided with a tongue, so it may be shifted with a team whenever necessary.

87. Time of application.—The proper time of application depends upon the age, the texture and the kind of manure, the crops to be grown, and the systems and the rotations to be followed. In the growing of truck crops in rotation with general field crops, perhaps, the manure should be applied at any convenient time previous to planting, and preferably upon grass land. If the manure is fine and the supply limited, it may be an advantage to use it as a top dressing after plowing, thoroughly incorporating it with the soil by harrowing. This is unquestionably the best method for hen, sheep and hog manures. In intensive gardening a crop may be removed, the manure applied, and the land plowed, harrowed and planted the same day. If 50 tons of manure to the acre are available annually and several crops are to be grown during the season, it is considered preferable to apportion the manure for each crop as may seem desirable rather than to use the entire amount at any one time.

88. Method of application.—As indicated in the previous paragraph, coarse manures should be plowed under, while those of fine texture will be most beneficial when used as a top dressing after plowing, especially upon heavy soils of moderate fertility. Surface applications after plowing certainly have a marked effect in improving physical conditions, in making soils warmer, more friable, and less subject to baking and washing.

A common practice in soils of rather low fertility is to use stable manures in hills or drills. This plan is seldom practiced by gardeners cultivating soils of high fertility,

but it is without doubt an advantage in the thinner soils, because it secures greater concentration of plant food in the immediate region of the roots and results in a more economical use of the manure applied.

The spreading of stable manures on truck farms and on market gardens is generally done with an ordinary four-tine manure fork. This is the most economical method when the manure is spread from the wagon as hauled from livery stables. Manure spreaders, however, should be in more general use among commercial vegetable growers, because they save labor and secure a much more even distribution than is possible by hand spreading.

89. Rate of application.—The rate of application varies with the character and the supply of available manure, the character of the soil and the kinds of crops to be grown. In field trucking with such crops as sweet corn and cabbage the applications often do not exceed 10 tons an acre, while in market gardening the amount varies from 25 to 100 tons an acre. More than 50 tons to the acre is regarded by some as wasteful, or at least not economical. Twenty-five tons is a medium application in market gardening, while many claim that maximum profits cannot be obtained with less than 50 tons an acre applied annually. In the most intensive garden operations manure is often spread to the depth of 3 inches. When supplementing with commercial fertilizers it is possible to succeed with less manure, although the land may suffer in its physical composition. By using commercial fertilizers and a good system of irrigation the grower can unquestionably economize in the amount of manure.

90. Night soil is a term applied to the human excrements, used extensively in the gardens near Philadelphia and for truck crops near Baltimore. At Baltimore it is taken from vaults and transported on barges to

truck farms and there pumped into large reservoirs, which are provided with double gates. When loading on the wagons, which are backed up to the spouts of the reservoirs, the outer gate is first closed and the inner gate opened. The space between the two gates holds a wagon load. When this space is filled, the inner gate is

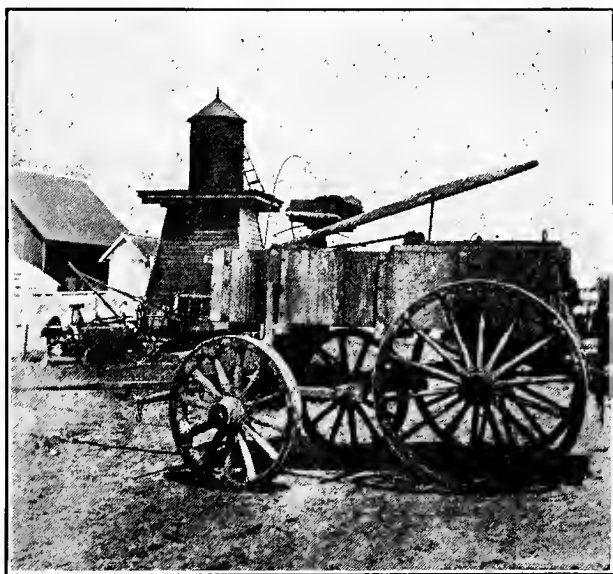

FIG. 10. NIGHT SOIL TANK-WAGON USED NEAR BALTIMORE

closed and the outer gate opened and the material is then conducted into the wagons, provided with tanks that are closed tightly when the wagon is in motion. In distributing over the field the end gate to the tank is raised by a lever operated by the driver, and the watery material is then spread over the slanting tail-board. Figure 10 shows the style of wagon used on the Patapsco Neck near Balti-

more. An analysis shows that the Baltimore night soil contains 0.28 per cent phosphoric acid, 0.2 per cent potash and 0.43 per cent ammonia and is worth about \$1.50 a ton. It is secured at a nominal cost, but if the unpleasant character of the material is taken into account, gardeners should be well paid for accepting and using it. In Philadelphia County considerable night soil is hauled in barrels with tight covers to market gardens providing dumping reservoirs. No charge is made for the material and no bonus is paid the gardeners.

CHAPTER VI

GREEN MANURES AND COVER CROPS

91. **As a source of humus.**—It has been previously indicated (76) that humus in large amounts is essential to success in every line of vegetable gardening and that stable manure supplies it in the best form. While this is true, it is impossible for thousands of commercial growers to secure enough stable manure to maintain the productiveness of their soils. This is particularly true of truckers living remote from great centers of population. It is easy enough for gardeners operating a few miles from the city to secure sufficient manure to produce good crops, but it is quite a different proposition for the grower living hundreds of miles from available supplies. It is impracticable for extensive truckers to use very freely manure which costs as much as \$3 a ton spread on the land. In many trucking sections it is not only much more economical to maintain the necessary amount of vegetable matter in the soil by the use of green crops, but it is also an effective means of keeping the soil in the proper sanitary condition.

92. **Extent used.**—The growing of green crops and catch crops for manurial purposes has become a general practice in many trucking sections. Marked progress in the use of green manures has been made in New Jersey, where, for example, at Freehold, potatoes have been grown annually upon the same land for many successive years by sowing crimson clover, rye or wheat after harvesting each crop of potatoes. It often happens that the continued use of crimson clover year after year results in an accumulation of too much nitrogen for the best results with potatoes and it is necessary to substitute rye

or wheat for a year or two. In the poor sandy soils of south Jersey, the land, after being cleared, is brought into a productive condition by sowing cowpeas in the early spring as soon as ground and weather are sufficiently warm, following with crimson clover plowed down the next spring after it has made considerable growth. Growers at Moorestown, Swedesboro, Glassboro and other New Jersey trucking centers employ green manures extensively. Crimson clover is the favorite crop for this purpose, but if the season is too far advanced to give it a good start before cold weather, rye is substituted. Peas and beans are also grown, and after the green pods have been picked and marketed the plants are plowed under. Throughout the North clover sods are largely depended upon, while crimson clover and cowpeas are popular southward.

93. The selection of crop.—In the selection of crops for manurial purposes the following factors should be considered: (1) Adaptation to climate; (2) adaptation to soil; (3) character of plant—whether a legume or a non-legume; (4) the amount of vegetable matter produced; (5) adaptation to system of cropping; (6) rapidity of growth; (7) character of root growth; (8) hardness; (9) ease of incorporation with the soil.

94. Red clover.—In the North, red clover is excellent to sow after the removal of the July or the early August truck crops. The surface of the soil should be made very fine and a firm seed bed established, and not less than 12 pounds of seed should be sown to the acre. The crop may be plowed down late the following spring before planting late cabbage and many other vegetables for fall and winter markets; or it may be mowed once and the second crop plowed down late in the fall preparatory to starting crops early the next spring.

95. Mammoth clover is practically an annual, which makes a larger and more vigorous growth than red

clover, and it is, therefore, more highly valued by some as a quick manurial crop. It should be sown at the same time as red clover.

96. Crimson clover.—As a cover crop crimson clover is used to a considerable extent in the middle Atlantic seaboard region. It is valued highly for its power to assimilate free nitrogen. A crop cut May 22 at the Delaware station (Delaware Station Bul. 60, p. 10) contained 180 pounds of nitrogen to the acre. The plant thrives best in sandy soils and where the winters are not too severe. It is unquestionably the most valuable manurial crop in the trucking sections of New Jersey.

The seed should be sown not later than August. July is not too early for the cooler sections. A common practice is to sow before the last cultivation of tomatoes, sweet corn and other late truck. Crops are sometimes harvested and the ground thoroughly harrowed before sowing crimson clover, while plowing before harrowing and sowing is often desirable. The seed soon loses its vitality and, therefore, only fresh seed should be sown. Not less than 15 pounds an acre should be used. The Virginia Truck Experiment Station claims that not less than 20 pounds an acre should be used at Norfolk.

97. Rye, while a nonlegume, is exceedingly valuable under certain conditions. It grows fairly well in any soil. This cannot be said of most cover crops. Because of this fact it is often possible to start with rye on very poor soils and then use more desirable crops after some humus has been added to the soil. Rye may be sown later in the fall than any other crop, and for this reason it is a valuable crop to start after the removal of late vegetables, when it would be useless to sow any of the legumes. It thrives throughout the North and is widely regarded as the best general purpose cover crop for cold sections. To secure a good stand not less than three bushels of seed should be used to the acre.

98. **Hairy vetch**, a legume, is valuable as a cover crop on the sandy soils of the North. To secure a maximum growth it should be sown in July. It is sometimes sown with rye.

99. **Oats and Canada field peas** when grown together make a large amount of vegetable matter. It is customary to sow about one bushel of peas with two or three bushels of oats. Both crops require cool climatic conditions. If they are allowed to attain considerable size, a rope or a chain must be adjusted to the plow to turn under the dense vegetation, which will undergo a rapid decomposition if plowed under when about 2 feet high. These crops should be started as early in the spring as possible. Oats may be used alone as an early spring crop or as a late fall crop.

100. **Cowpea**.—This is a valuable soil-improvement crop in all sections of the South. It requires a large amount of heat and no attempt should be made to grow it in the coolest parts of the North. Under favorable conditions the plants produce a large amount of highly nitrogenous vegetable matter in a remarkably short time. The seed should never be sown in the spring until the ground is thoroughly warm. Cowpeas, also, work in to good advantage between spring and fall crops; that is, in many sections spring vegetables may be sold, and cowpeas grown and plowed under before the time for starting fall crops, such as kale, spinach and early cabbage planted in the fall. The Virginia Truck Experiment Station states that a crop of cowpeas plowed under green in the fall gave as large a yield of cabbage to the acre as 20 tons of stable manure. This station urges the use of lime in conjunction with green crops.

The most valuable varieties for manurial purposes are Whippoorwill, New Era, Iron and Unknown or Wonderful. It is necessary to chop up the vines with a disk harrow before they can be plowed under with any degree

of satisfaction. The customary sowing is about two bushels of seed to the acre covering with a harrow.

101. **Soy bean**, also a legume, succeeds better on heavy soils and in cool climates than the cowpea and is, therefore, valued by some northern growers as well as southern truckers for manurial purposes. The seed may be sown broadcast or in drills. Cultivation is a great benefit to the crop.

102. **Fertilizing green manurial crops.**—When crops for manurial purposes are grown on impoverished soils, commercial fertilizers should be used liberally enough to encourage a good growth. It may pay to use 500 pounds to the acre of a high-grade fertilizer. Nitrogen is especially important for the nonlegumes.

103. **When to plow under green crops.**—No very definite advice can be given upon this question, because many factors must be taken into account, such as kind and age of crop, vegetables to follow, needs of the soil and seasonal conditions. The older the crop the more time will be required for its decomposition and the less benefit it will be to the next cash crop. Soil moisture problems are especially important in connection with green manures. When plowing is delayed too long, the ground may become too dry for successful sowing or transplanting. To prevent serious interference with the capillary movement of the soil moisture, the furrow slice should be stood on edge as much as possible rather than turned flat. Rolling or dragging immediately after plowing is regarded as valuable in preventing the development of soil acidity.

CHAPTER VII

COMMERCIAL FERTILIZERS

104. Necessity of commercial fertilizers.—It is not uncommon to find market gardens managed successfully without the use of commercial fertilizers. In all such cases stable manures and perhaps night soil are applied in liberal quantities. Although it is possible to make large profits when fertilizing with manures only, it is doubtful whether there are any instances when commercial fertilizer in some form could not be used to advantage. Manure is an unbalanced ration; it is richer in nitrogen than in mineral elements and there is likely to be a surplus and, therefore, a waste of nitrogen when it is applied without corresponding additions of potash and phosphoric acid.

The most forceful argument for the use of commercial fertilizers is the inadequate supply of animal manures. While hundreds of market gardeners near the cities depend mainly upon stable manures, thousands of truckers remote from the great sources of supply must resort to the use of commercial fertilizers in order to secure maximum returns.

There are other reasons for the use of commercial fertilizers. Stable manure must undergo changes before it is accessible to plants, while some of the commercial fertilizers are immediately available when incorporated with moist soil, a characteristic which gives chemical fertilizers a great advantage over stable manure, for it is possible to mature crops in less time by their use than can be done with manure alone. Rapid growth is of immense importance in commercial vegetable gardening. Therefore, with the aid of commercial fertilizers the gardener

may be able to harvest several crops from the same ground in one season, to clear the land in time to start a cover crop or mature a green manurial crop before cold weather, and to secure far better quality than is possible when the growth is slow. The quality of many vegetables is closely associated with rapidity of growth. A slow growth is likely to cause a bitter flavor in lettuce, a sharp flavor in onion and a pungent flavor in radish. Again, slow growth is certain to cause greater development of fiber, making the vegetables tough, woody or stringy. A rapid growth usually secures succulence, crispness and palatability. And, in addition, rapid-growing vegetables are less subject to injury from insects and diseases than are slow-growing ones.

105. The use of nitrogen.—Of the three elements supplied by commercial fertilizers to garden crops, nitrogen is more frequently the limiting factor than either potash or phosphoric acid, because in cultivated soils it is lost more quickly and, also, because it is more expensive to buy, and therefore likely to be supplied in less abundance. Nitrogen plays the most important part in the growth of leaves and succulent stems, and therefore it is particularly valuable in the production of such crops as cabbage, lettuce, brussels sprouts, spinach, kale, swiss chard, endive, celery, sweet corn and asparagus. Also, large amounts of nitrogen are very necessary in growing onions.

Nitrogen is valued largely according to its availability. For this reason nitrate of soda is considered by commercial growers the most valuable nitrogenous fertilizer. It is available to the plant as soon as dissolved, while stable manures, dried blood, tankage, bone meal and other organic materials must rot or decay before they are of any benefit as plant foods. For the money invested probably no other fertilizing material is capable of giving such large net returns, provided all conditions are

satisfactory for its use. Many experiments have been made at the New Jersey station, and one of the bulletins (N. J. Sta. Bul. 172, p. 11), which reports the results, contains the following statement: "It is quite possible to have a return of \$50 an acre from the use of \$5 worth of nitrate of soda on crops of high value, as, for example, early tomatoes, beets, cabbage, etc. This is an extraordinary return for the money invested and labor involved; still, if the value of the increased crop from its use was but \$10, or even \$8, it should be regarded as a profitable investment, since no more land and but little more capital were required in order to obtain the extra \$5 or \$3 an acre. It is the accumulation of these little extras that oftentimes change an unprofitable into a profitable practice."

The amount of nitrate of soda applied to the acre at any one time may vary from 100 to 250 pounds. Larger applications are sometimes made, but they are of doubtful economy. The better and safer practice is to make frequent applications of smaller quantities.

There are no rules concerning the frequency of applications, but it depends upon the fertility of the soil, the character of the crop and the time of planting. Nitrate of soda is especially valuable for early spring applications before soil nitrification becomes active. If used when the ground is cool it may be the means of encouraging a rapid growth when all other agencies fail. A common practice is to see that some nitrate is contained in the fertilizer applied before planting. After two or three weeks a second application of the nitrate can often be made with profit, and additional ones are frequently advantageous. For more specific information on this question see Chapter XXI on the cultivation of different classes of vegetables.

The following methods may be employed in applying nitrate of soda: (1) It may be applied alone or mixed

with other fertilizers before sowing or transplanting. If the soil does not contain a large percentage of sand, the loss from leaching is not likely to be serious. (2) As a top dressing around the plants or along the rows. This may be done by hand or when space will permit with a side-delivery fertilizer distributor. (3) In dry weather it is an advantage to open furrows along the rows, distribute the nitrate in the furrows and then close them with a small shovel or hiller; the same purpose may be accomplished by the use of a drill; or even by cultivation, after an application on the surface, the fertilizer may be mixed thoroughly with the moist soil. (4) The quickest and easiest way to apply this salt is to sow by hand with a full swing of the arm, as when sowing clover seed, letting the fertilizer fall where it will. Many gardeners who have adopted this labor-saving plan claim that it is safe in fertilizing plants, even those which have tender leaves, provided the foliage is perfectly dry, for every crystal that strikes the leaves naturally rebounds or glances to the ground. The broadcasting method is safe for cabbage, even if the salt lodges in the axils of the leaves. (5) Nitrate may also be dissolved in water and then applied by means of a hose; or better, by the Skinner system of irrigation. One ounce of nitrate to one gallon of water is the proper proportion for most purposes. If there is fear of burning the foliage, clear water may be sprayed on the plants after the solution of nitrate has been applied.

Nitrogen may be supplied in various other forms: Raw or steamed bone may furnish 3 to 6 per cent of nitrogen, although the nitrogen in this form becomes available very slowly; dried blood, which contains from 6 to 14 per cent of nitrogen, decomposes rapidly; ground fish, which contains 7 to 8 per cent of nitrogen, is used extensively in some trucking regions. Tankage varies greatly in composition, ranging from 4 to 12 per cent of nitrogen; cot-

tonseed meal decays rapidly and ranks with blood in the availability of its nitrogen, but its high value as a cattle food is rapidly reducing its use as a fertilizer; natural or Peruvian guanos were formerly used very extensively, but the supplies are practically exhausted, so the material is now of little commercial importance. Nitrogen for all classes of vegetables should be derived from at least two different sources, usually including nitrate of soda.

106. The use of phosphoric acid.—Phosphoric acid is most essential in growing cereal crops, but it is scarcely less important in vegetable gardening. Soils deficient in phosphorus fail to give large yields and the crops are also slow in maturing. In vegetable gardening, more importance is attached now to the use of phosphoric acid than ever before, and the gardener should not lose sight of the fact that most soils are lacking in this plant food.

Rock phosphates are the chief sources of supply. They vary from 12 to 18 per cent in available phosphoric acid. Raw and steamed animal bone are also in common use, and bone tankage is employed by some vegetable growers. Thomas slag, also known as iron phosphate and Thomas phosphate, which contains 15 to 20 per cent of phosphoric acid, is another desirable form.

107. The use of potash.—Potash is especially important for the root crops, as beets, carrots, turnips, radishes and parsnips. It also enters largely into the composition of many other vegetables. Applications are particularly important for sandy soils and for muck lands.

Muriate of potash is the most common form used by vegetable growers; but sulphate of potash is preferred for potatoes, and kainit is used sometimes by asparagus growers.

108. Rate of application.—The rate of application of chemical fertilizers depends upon such factors as (1) the character of the soil, (2) the previous crop grown and the manner in which it was fertilized, (3) the moisture

conditions, (4) the importance of early maturity, (5) the possibility of irrigation, (6) the amount of land available and (7) the character of the crop to be grown. Applications vary from a few hundred pounds to two or more tons to the acre. One ton to the acre for a single crop is considered liberal, although this amount is often exceeded. At Norfolk, Virginia, 3000 pounds are frequently applied during the season. While dangers attend the free use of fertilizers (109), the only sound business policy is to apply the various elements in fully sufficient quantities. Regarding this matter, Dr. Edward B. Voorhees says (Voorhees, *Fertilizers*, p. 264): "Apply a reasonable excess of all the essential fertilizer constituents to all of the crops. Nevertheless, because of the peculiarities of growth of the different plants, as well as the different objects of their growth, distinctions should be made in reference to the kinds and amounts of plant food applied, and these conditions should be borne in mind, in order that the most profitable results may be secured." (See notes on fertilizers in Chapter XXI.)

109. Dangers of excessive applications.—When approved methods of soil management are followed, practically no danger attends the use of large amounts of commercial fertilizers. If the amount of vegetable matter decreases and the soil acidity increases, several difficulties may develop. The soil may become hard and unproductive, not because of large applications of fertilizers, but because of small additions of humus. With the continued application of large quantities of mineral fertilizers the soil may become extremely acid, when leguminous cover or green manurial crops cannot be grown successfully. Malnutrition diseases sometimes develop in strongly acid soils, especially if humus is deficient.

The causes and the control of malnutrition disease have been studied by the Virginia Truck Experiment Station. When the disease is present the following symptoms may

be observed (Va. Truck Expt. Sta. Bul. 1, p. 5): (1) "The plants stop growing when they should be making their most rapid development. In many cases they slowly weaken and die, while in others growth is resumed later in the season after rains have occurred. (2) There is a change of leaf color to a lighter green, especially in the spaces between the veins, which turn yellowish-green or even brown. In cabbage the margins of the leaves are frequently of a uniform yellow color. (3) The roots of the affected plants are poorly developed. Many of the lateral feeders are killed back repeatedly, until the root system becomes stubby. (4) No fungi or bacteria can be connected with the disease. In most cases none is present."

In the Norfolk region 3,000 pounds of fertilizer to the acre are often applied during the season's operations and this amount is used year after year, resulting in a strongly acid soil. The Virginia Truck Experiment Station states also (Va. Truck Expt. Sta. Bul. 1, p. 5) that "acid soils are less favorable for the production of most truck crops than neutral soils. A slight amount of acidity is not ordinarily injurious, but examinations made at our request by the Bureau of Soils of samples from fields where cabbage suffered from malnutrition, showed these soils to be abnormally acid, so much so that 3,500 to 6,300 pounds of lime would be required to neutralize an acre to a depth of 1 foot. This condition is apparently the result of many years of intensive trucking, involving the use of repeated heavy applications of commercial fertilizers made up in large part of chemicals which leave the soil more acid.

"Only a portion of the fertilizer applied is actually taken up by the plants, the remainder being left in a different form, which will have an influence on the soil reaction. For example, sulphate of ammonia, muriate and sulphate of potash, and acid phosphate tend to leave

the soil more acid, while nitrate of soda, carbonate of potash and Thomas phosphate tend to make the soil alkaline. In the brands of fertilizers most used in this section, the acid-forming ingredients largely predominate.

“One of the most important factors contributing to malnutrition is the exhaustion of the organic material in the soil. Fields where this disease occurs are found to contain only 1.65 per cent organic matter, while normally 3 to 5 per cent should be present.

“This deficiency is to be expected from such complete dependence on commercial fertilizers, which cannot take the place of stable manures and green manures in a permanent system of agriculture.

“Remedial and preventive measures recommended for malnutrition diseases are: (1) Limitation of the amounts of fertilizer used; (2) adjustment of the composition of the fertilizer to suit the crop requirements; (3) the rational use of lime; (4) the maintenance of the organic matter of the soil.”

110. **The use of lime.**—The necessity of lime has been indicated in previous paragraphs. Malnutrition disease may become serious when lime is not used or when soils become acid. In vegetable gardening it is important to keep soils slightly alkaline and this is best accomplished by the rational use of lime. Va. Truck Expt. Sta. Bul. 4, p. 80: “Experiments on Norfolk soils show that liming is very beneficial to all crops except peas, beans and tomatoes. On cabbage lime was added in the spring of 1909, just before planting, and the yield was greatly increased thereby. The succeeding year the experiment was extended to include other crops, and the yield of all crops except peas and beans was markedly increased.”

Lime not only neutralizes soil acidity, thus providing favorable conditions for friendly micro-organisms, but it also improves the physical character of soils, promotes decomposition, makes plant food available and enters into

the composition of plants. It is also the best known preventive for club root of cabbage and allied crops.

Spring applications of lime gave better results at Norfolk than fall treatment. Lime should never be applied with manure, because it releases the ammonia. When both manure and lime are to be applied to the same soil it is best to plow under the manure, then spread the lime and mix thoroughly with the soil by harrowing.

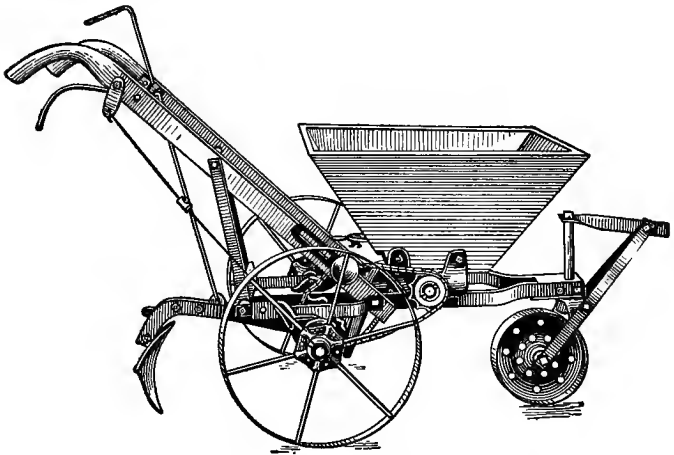

FIG. II. SINGLE-ROW FERTILIZER DISTRIBUTOR

The acid soils at Norfolk require from 3,500 to 6,300 pounds of lime to the acre to become alkaline. A ton of lime on many soils would be sufficient for the best results.

III. Related questions.—When a grower learns that it is possible to increase profits materially by the use of fertilizers there is danger of his depending too much upon special plant foods and not enough upon other closely related questions, such as tillage, soil moisture and the supply of humus. It should be borne in mind that no

amount of fertilizer will make up for poor tillage, insufficient soil moisture and a small percentage of vegetable matter. More than this, the fertilizers applied will not be of full value unless all other conditions are satisfactory. It is impossible to incorporate fertilizer thoroughly in a poorly prepared soil. If the moisture content is insufficient the fertilizer cannot decompose or enter into solution to become available to the growing plants. Again, soils lacking in organic matter cannot continue to

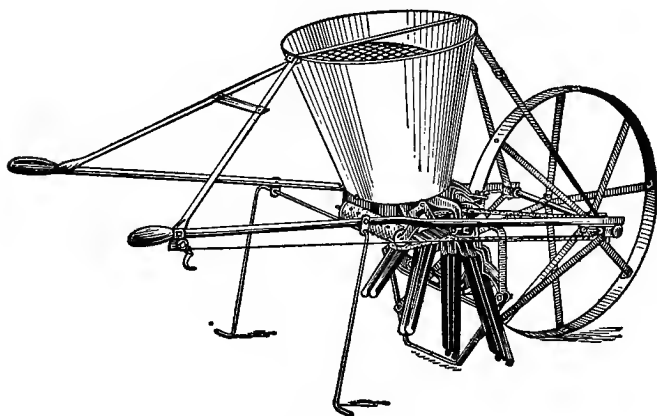

FIG. 12. WHEELBARROW FERTILIZER DISTRIBUTOR

produce large crops even with the lavish use of fertilizers. Harmony of all conditions must exist before it is possible to harvest maximum crops of high quality.

112. **Methods of application.**—In vegetable gardening commercial fertilizers should be applied after plowing and before much harrowing has been done. The fertilizer will then be mixed thoroughly with the soil in making preparations for sowing or planting.

Various drills and distributors have been placed on the

market for applying fertilizers. Figure 11 shows a single-row distributor, and Figure 12 a wheelbarrow style. Both of these are very useful in some lines of garden work. The McWhorton distributor (Figure 13) is one of the best types; it may be adjusted to apply from a few hundred pounds to two tons to the acre. A lime spreader is shown in Figure 14.

While the various drills and machines are convenient and usually save labor, fertilizers may be sown satisfactorily and at small expense by hand. Bags of 50, 75 or 100 pounds should be distributed at proper intervals over the field to secure the desired application to the acre.

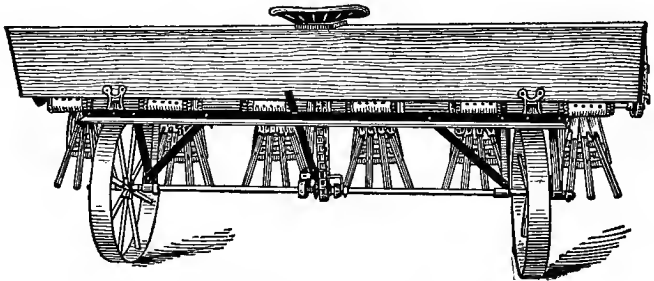

FIG. 13. M'WHORTON FERTILIZER DISTRIBUTOR

The material may then be carried in a bucket or a bag, and sowed with the same movements of arm and hand as are used in broadcasting clover seed. A more even distribution is possible, however, with machines.

113. Purchasing fertilizers.—It usually pays to buy only high grade fertilizers for vegetable gardening. They should be bought, of course, on guarantee. Not only is it important to know the percentages of the various elements, but the grower should know the sources. This information is not always procurable, but it is exceedingly important. Intelligent plant feeding is not possible with-

out knowing the source of the various materials which enter into the composition of the brands used.

114. **The home mixing of fertilizers.**—Home mixing of fertilizers is increasing in popularity. The following advantages may be mentioned: (1) The grower knows exactly the kind and amount of each ingredient used; (2) he can adapt the mixture to the needs of the different classes of crops to be grown; (3) he can adapt the mixture to the needs of the particular soil to be cropped; (4)

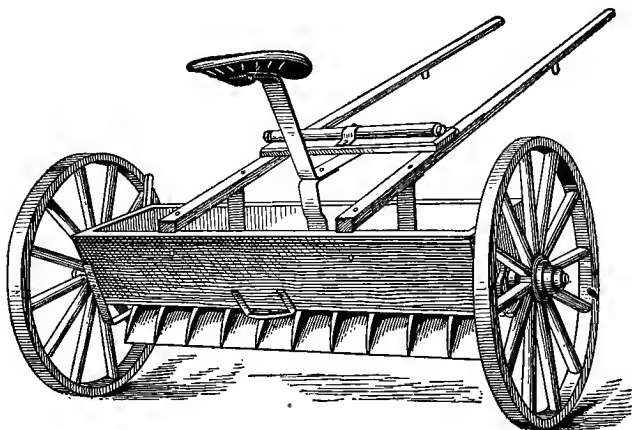

FIG. 14. LIME SPREADER

he usually saves several dollars a ton; (5) he becomes more intelligent every year in the application of the principles relating to plant nutrition.

Numerous experiments have proved that home-mixed fertilizers are fully as valuable as factory-mixed goods of equivalent composition.

The arithmetic of home mixing is very simple. Suppose fertilizer is wanted that will contain 4 per cent of nitrogen, 8 per cent of phosphoric acid and 10 per cent of

potash. (Dr. Edward B. Voorhees calls a mixture of this composition the basic fertilizer.) The nitrogen should be derived from at least two sources, say nitrate of soda, and an animal product, as dried blood. To make a more simple example, we will suppose that the nitrogen is to be derived from nitrate of soda, the phosphoric acid from acid phosphate and the potash from muriate of potash. It simplifies matters to think of percentages as pounds. Four per cent of nitrogen means four pounds in each hundred pounds or 80 pounds for the ton. As nitrate of soda contains about 16 per cent nitrogen, it is readily seen that 500 pounds of this salt will be required to furnish the required amount of nitrogen. We will suppose that the acid phosphate is 17 per cent available, and 160 pounds of phosphoric acid are needed. By dividing 160 by .17, we learn that 941 pounds of rock phosphate are required. Muriate of potash contains 50 per cent of actual potash. By calculating in the same manner it is ascertained that 400 pounds of this ingredient is required to supply the potash. These three materials aggregate 1,841 pounds. To make a ton it is necessary to add some foreign matter, as sand. The sand would be known as the filler, which is of no value, but it increases the cost of freight, drayage and application to the land.

The home mixing of fertilizers is a very simple operation. Two men provided with short-handled shovels can do the work rapidly upon any smooth floor. The bottom of the shovels should be flat and the corners square. The grower should also provide a sand screen with a $\frac{1}{4}$ -inch mesh, not less than 3 feet wide, 5 feet long, and mounted on a frame that may be propped up at any angle to the floor.

It is not convenient to mix more than half a ton at a time. The various materials are weighed and spread in a flat pile, each ingredient constituting a separate layer. The sand screen is placed conveniently near the pile and

at an angle of about 45 degrees to the floor. The men stand on either side and shovel the fertilizer up on the screen. The finer particles fall through and the lumps roll to the bottom of the screen, where they can be crushed with the shovels. After the pile has been screened in this manner the screen is set aside and the pile shoveled over twice. When shoveling the bottom of the shovel should be kept on the floor to secure thorough mixing.

After mixing, the material should be rebagged in convenient amounts. A common practice is to place 100 pounds in each bag. A uniform amount in the bags is necessary to make an even distribution over the field before spreading or drilling. Mixing and rebagging should not cost more than 50 cents a ton. To prevent the forming of hard lumps the mixing should not be done more than a month before applying, especially if chemicals are largely used.

CHAPTER VIII

IRRIGATION

115. The extent of irrigation.—Irrigation has been developed to a great extent in arid and semi-arid regions of the West, but not until recent years have intensive growers in the East taken a general interest in the subject. The quickened interest has been due mainly to improved methods and the increased importance of avoiding losses from drouth. Notwithstanding the improvement in implements, production costs more than ever before, and men appreciate more fully the importance of controlling all conditions, thus making every crop a success so far as production is concerned. It seems inconsistent for an intensive grower to spend large sums of money in providing right conditions in every respect except one, which he neglects entirely. Of the factors contributing to the growth of a healthy plant, water is the most important. Scientists have been telling us this for years and it seems strange that practical men have been so slow to grasp the idea. But conditions have changed and vegetable growers in all sections of the United States are giving attention to artificial methods of watering. Hundreds of gardeners every year are installing irrigation systems. The movement is particularly active near the large cities, but it is spreading into all communities where vegetables are grown for commercial purposes.

116. Opportunities for irrigation.—Throughout the eastern part of the United States there are thousands of opportunities for successful irrigation. Creeks, rivers, ponds and lakes furnish an abundant supply of water, which, in many instances, is available at slight cost. It is not uncommon to find conditions where water might

be conducted to the garden by gravity, so there would be no expense for pumping. In many more instances a lift of 5 to 15 feet would put the water on land admirably adapted to garden crops. Near the cities water can usually be secured at reasonable prices, and at some places for as low as 4 or 5 cents a thousand gallons. The late W. W. Rawson, the well-known New England gardener, claimed that an intensive grower could well afford to pump water at a cost of 10 cents a thousand gallons. If it were a matter of saving a crop from almost total loss it might pay to use water at double this cost.

117. Functions of water.—Before entering into a practical discussion of the subject of irrigation the student or the reader should fully realize what an important part water plays in the growth of plants. (1) It is a powerful solvent of plant foods. No matter how fertile a soil may be naturally, or how much manure or fertilizer may be added, such foods are valueless without water to dissolve them. Both stable manures and fertilizers often fail to give increased yields because of insufficient soil moisture. (2) Water not only serves as a solvent, but it holds in solution organic acids which are more powerful solvents than water alone. (3) Water is essential to the life of friendly bacteria. (4) Water serves as a vehicle in the distribution of plant foods in the soil.

Its functions in the plant are equally important. (1) Water enters largely into the composition of all garden products. Many vegetables contain over 90 per cent of water. (2) Water is also a medium in the conveyance of food in the plant, so that enormous quantities transpire from the leaves. Several hundred pounds of water are required to produce every pound of dry matter. It is claimed that a well-developed hill of cucumbers will use half a barrel of water in three days. (3) The transpiration of water has an important relation to the fixation of carbon from the atmosphere.

118. **The benefits of irrigation.**—Irrigation is an insurance, for rainfall is uncertain, and the gardener never knows when it may become necessary to start the pumps or open the water lines to prevent loss. It is a great satisfaction to realize that one can be practically independent of the natural rainfall.

Seeds cannot germinate without moisture. It often occurs that plants do not come up promptly because of a lack of moisture. This trouble may be easily avoided by an up-to-date system of irrigation. Again, transplanting is often an uncertain operation. Hot, drying winds and bright sunshine, after planting, may cause an almost total loss of the plants, while irrigation would save them.

Absolute control of moisture conditions makes it possible to secure large yields, better quality and earlier maturity. These three advantages are of immense importance from a business standpoint. All classes of vegetables should grow unchecked, and this is impossible when moisture is wanting.

Drouths occur in all sections almost every year. They are disastrous to satisfactory returns. It happens not infrequently that \$200 or even more an acre is lost during protracted drouth. This would more than pay for the installation of the most approved system and the application of water during the period of drouth.

It has been previously stated that the rate of applying stable manures and commercial fertilizers may be reduced when irrigation can be practiced. This may not be the best business policy, but it is unquestionably true that irrigation is often worth much more than any amount of manure or fertilizer that can be applied.

Numerous experiments have been made that show the value of irrigation. For example, at the Michigan Station an experiment was conducted on a 10-acre plot. Tomatoes and potatoes were irrigated four times and the

other vegetables in the test three times, about an inch of water being applied each time, while the same vegetables were grown under natural conditions. "The cabbage crop suffered most of all, perhaps, as where water was not used less than half formed heads of marketable size, and these were small. Of the Early Jersey Wakefield there were 5,000 more marketable heads to the acre obtained by the use of water and the weight was 11,325 pounds greater. Early Summer showed a gain of 4,826 heads and 21,959 pounds in weight. At 2 cents a head the gain to the acre would average nearly \$100. A gain of 200 bushels an acre was obtained with the irrigated tomatoes, which at 50 cents a bushel would amount to \$100, or ten times the expense of applying the water. Snap beans showed a gain of 300 bushels and early peas of 100 bushels an acre. Four applications of water to potatoes gave a gain of 129 bushels an acre. Marked improvement in quality was also noticeable with peas, beans and cabbage." Such gains, of course, could not be expected in normal seasons.

The New Jersey Station (N. J. Sta. Bul. 115) reports the following interesting results: "For beans, in terms of good-sized pods, the average yield of the nine non-irrigated belts was 17 pounds and 1 ounce, while the yield from the irrigated belt was 45 pounds, or nearly three times as many, besides being much larger sized and of finer color and quality.

"For peppers the average yield upon the 11 nonirrigated belts was 717 fruits, while the number upon the irrigated belt reached 1,277. This does not show the whole difference, for by measure an unirrigated belt gave $6\frac{1}{2}$ peach basketfuls, with a total weight of 80 pounds, and the irrigated belt $11\frac{1}{4}$ baskets, weighing 147 pounds. The difference is still more than these figures show, for the irrigated ground gave much better looking peppers in plumpness and color than the nonirrigated land,

with the quality far superior. The fruit from the irrigated plants would sell at the highest price, when those from the nonirrigated plants might go at a low figure.

“The increase of $4\frac{3}{4}$ baskets of peppers, to say nothing concerning the great superiority of the whole crop over that of the nonirrigated belts, cost for the water $24\frac{1}{2}$ cents (24.46), which in round numbers is 5 cents (5.14) a basket.

“The total weight of celery was $465\frac{1}{2}$ pounds, $329\frac{1}{2}$ pounds being produced in the irrigated and 136 pounds in the nonirrigated rows. In round numbers this is two and one-half (2.40, to be exact) times as much celery upon the irrigated as upon the nonirrigated land. However, these figures do not indicate the full difference of market value, for the irrigated celery was of good size and quality, readily salable at a fair price, while the nonirrigated rows yielded a crop that was worth less than the cost of production. After the plants were prepared for market by removing the worthless outside leaves and the roots, it was shown that the loss from the irrigated was 28.57 per cent, while from the nonirrigated it was 40 per cent, which is a much greater loss for the smaller plants than for the larger.

“The difference between the marketable products of the two rows is in round numbers three to one; but when the selling price is considered, the difference is not far from eight to one in favor of irrigation.”

The late W. W. Rawson, a highly successful and extensive market gardener of Boston, practiced irrigation many years ago, and was an earnest advocate of artificial watering. He said (“Success in Market Gardening,” Rawson, p. 27): “We cannot believe there is even an acre of growing crop which, in a dry time, would not be benefited by such a watering to an amount much more than the cost; though many people shrink from the expense involved, and are skeptical about getting full return from

the outlay." Again, he says in the same connection (*ibid.*, p. 27): "It has oftentimes occurred that such a watering, once or oftener applied, has saved a crop that, without it, would have been a complete failure. For my part, I would as soon think of being without a steam pump as the farmer who cuts hay would of being without a mowing machine. There is very seldom a season so wet that the steam pump will not be required 2 or 3 weeks, and in most seasons it will be in use 8 to 10 weeks. When the weather is very dry, and all the crops need abundant watering, the pump should be kept running night and day, by employing two sets of men. . . . I would rather have a piece of 10 acres well fitted up for irrigation than one of 20 without irrigation; and I venture the assertion that I could raise more vegetables or receive more money for my crops, in a period of 10 years from the 10 acres irrigated than from the 20 acres nonirrigated." Mr. Rawson once sold \$3,500 worth of cauliflower from 6 acres of irrigated land, and he believed that not over \$1,000 would have been realized without irrigation. The prospective irrigator should bear in mind that prices average higher in seasons of drouth.

119. The furrow method of irrigation is in most general use in the vegetable-growing section of the West and has been used to some extent in the East. The main argument in its favor is that with suitable contour of the land very little expense is involved in the making of ditches or furrows. On the other hand, the system has several disadvantages: (1) Considerable attention is required to operate this system. (2) It is not easily used on land of uneven contour. (3) It is not successful on very open, porous soils nor upon impervious soils. (4) It fails to secure an even distribution of water. (5) It may cause serious baking of the areas occupied by furrows.

120. Hose applications.—Rubber hose is often used in making applications of water. At Boston it is a very common method. Three acres may be watered in a day by using a large, open hose, which, with sufficient pressure or pump capacity, will throw 100 gallons a minute. Although this method has been used with great success, it is open to severe criticism. Too much expense is involved in keeping constant attendants, and even distribution is impossible; the water is also applied too rapidly for most soil types; and heavy soils would tend to bake and become too solid were this method followed.

121. Subirrigation has been investigated at a number of the experiment stations, but has not become generally popular among market gardeners. The details of installment may vary greatly. The pipes are usually ordinary drain tile, which range in size from $2\frac{1}{2}$ to 4 inches. They may be only a few inches under the surface or 2 or 3 feet, depending upon climate and soil conditions and crops grown. Eight to 12 inches are proper distances for most garden soils, and the lines should be 10 to 15 feet apart. The tile are placed end to end as close together as possible and the end of the line farthest from the water main closed. A $\frac{3}{4}$ -inch stream of water should cause water to flow to the end of a 200-foot line of tile.

Theoretically, this is a fairly good system of watering. There is smaller loss by evaporation from the surface than with any other system; there is less baking of the soil and the least amount of tillage is required, and in addition, tillage is never delayed because of a wet surface. On the other hand, considerable outlay is required for tile, which must be laid, lifted and stored every year, unless placed below the frost line. Percolation is too rapid and capillary action too slow in most soils. It is doubtful if this system will ever be generally used.

The most extensive system of subirrigation in the United States is at Sanford, Fla. Large tracts of waste

land have been brought under cultivation and utilized in growing lettuce, celery and other crops. The tile serve both for irrigation and for drainage. An impervious bed of hardpan lies from 2 to 4 feet below the surface and the sandy or loamy top soil is about 18 inches deep. The 4-inch water mains are made of sewer tile, cemented at the joints, the 3-inch laterals of drain tile are 20 to 25 feet apart and 12 to 15 inches below the surface. Sawdust, cinders

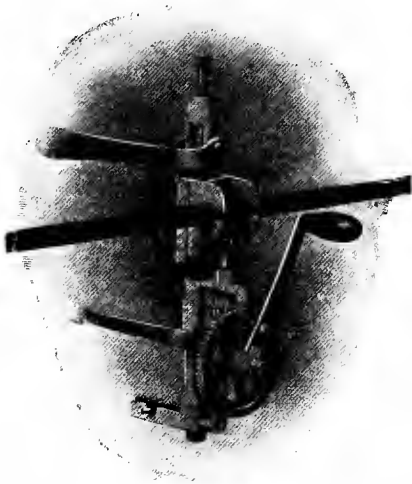

FIG. 15. DRILLING MACHINE FOR THE INSTALLATION OF THE SKINNER SYSTEM OF IRRIGATION

or moss are placed over the joints to prevent filling with sand. A fall of at least 1 inch in 100 feet of tile is provided for drainage. The laterals run into open ditches dug for drainage purposes. Subirrigation is an ideal system for conditions as they exist at Sanford.

122. The overhead system of irrigation promises to revolutionize garden irrigation in the East. Numerous

plans, some of which have been described, have been used to a very limited extent since the early days when Peter Henderson was a practical gardener on Long Island. None of the methods, however, became universally popular until the Skinner system was introduced in 1904. This is an overhead method used in hundreds of gardens and greenhouses. Its success, when properly installed, is universally admitted.

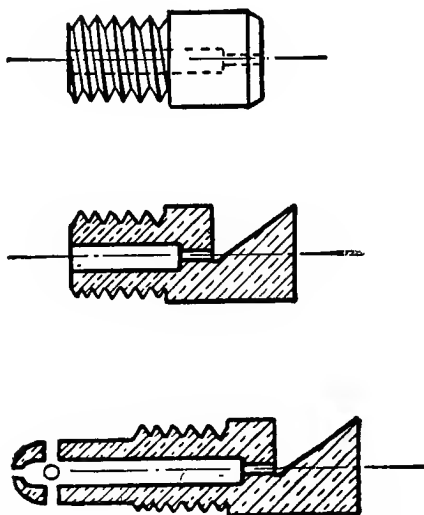

FIG. 16. NOZZLES FOR THE SKINNER SYSTEM OF IRRIGATION

The advantages of this system of watering may be summarized as follows: (1) The water falls in the finest spray, thus preventing the washing and hard incrustation of the soil; (2) the water is distributed with the greatest uniformity; (3) there is no injury to the plant by the force of the water; (4) very little labor is required to operate the system; (5) because the water falls as in

a gentle shower the foliage is cleansed and the effect is to encourage the most healthful and vigorous growth; (6) insecticides and fungicides and liquid fertilizers may be applied through the water lines; (7) the cost of installation is low, considering the merits of the system. It varies from \$90 to \$150 an acre.

Water may be pumped directly into the system, or reservoirs may be constructed to hold it. When water from a city reservoir can be secured at a reasonable price

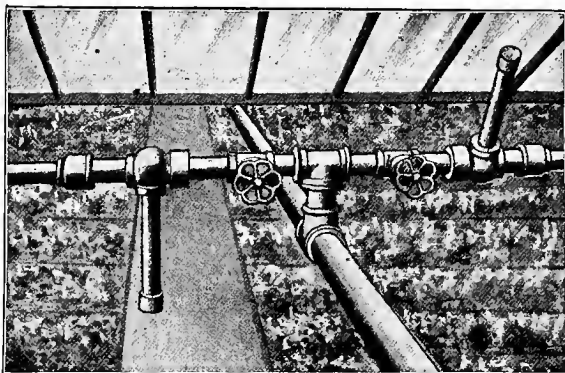

FIG. 17. UNION FOR THE SKINNER SYSTEM OF IRRIGATION

the problem is very simply solved. A great many growers, however, pump directly into the system. The water mains or feeders should be of ample capacity to supply the nozzle lines.

All nozzle lines should be of galvanized pipe and of the size indicated in the accompanying table. The pipes are generally 50 feet apart in outdoor irrigation, and should be supported on posts about 25 feet apart. Two-inch pipe is generally used for posts, while some gardeners use cedar or locust posts.

Figure 15 shows the position of the patented drilling machine when in operation. This work must be done with the greatest care. The nozzles, also patented, are placed 4 feet apart for outdoor irrigation and 3 feet apart for greenhouse watering. They must be in perfect alignment. Different nozzles (Figure 16) are used for greenhouse and outdoor work. A patented union (Figure 17) is also required for the installation of this system.

SIZES OF PIPE FOR OUTDOOR NOZZLE LINES

Calculated on outdoor nozzles placed 4 feet apart. If the nozzles are closer together larger pipe must be used.

Nozzle No.	Length of line feet	No. feet $\frac{3}{4}$ -in. pipe	No. feet 1-in. pipe	No. feet $1\frac{1}{4}$ -in. pipe	No. feet $1\frac{1}{2}$ -in. pipe	No. feet 2-in. pipe
No. 1 Outdoor	150	150				
	200	130	70			
	250	100	150			
	300	100	150	50		
	400	90	160	150		
	500	90	160	150	100	
	600	90	160	175	175	
	700	90	160	175	175	100
No. 2 Outdoor	150	115	35			
	200	100	100			
	250	90	100	60		
	300	90	100	110		
	400	80	100	120	100	
	500	75	100	120	120	85
	600	75	100	120	120	185

DISTANCE BETWEEN NOZZLE LINES FOR OUTDOOR IRRIGATION

Nozzle No.	Pounds pressure	Distance between lines, feet	Nozzle No.	Pounds pressure	Distance between lines, feet
No. 1 Outdoor	10	40	No. 2 Outdoor	45	60
	20	50		75	60
	40	56		80	56
	45	56		100 and over	50
	50	54			
	75 and over	50			

The greater the pressure the finer the spray; but after reaching a certain pressure the spray is so fine that it retards the flow of water and reduces the distance of throw. It follows that when the pressure is so high as to produce these results, the lines must be installed slightly closer together, according to the preceding table. The preceding figures refer to pressure at nozzles.

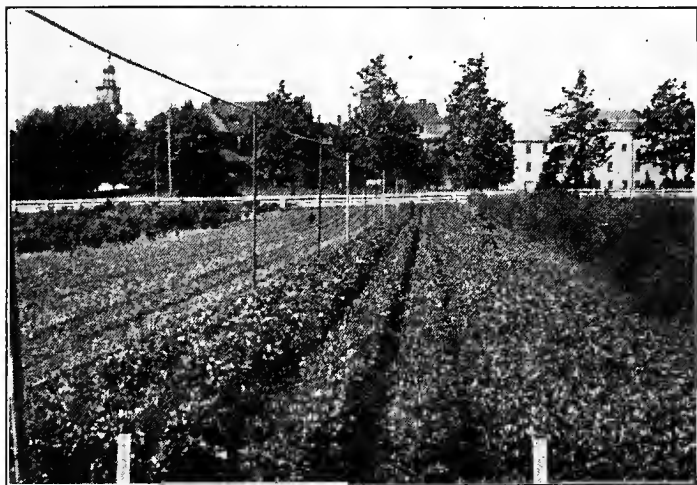

FIG. 18. IRRIGATION SYSTEM INSTALLED AT THE PENNSYLVANIA STATE COLLEGE

Figure 18 shows the overhead system in use at the Pennsylvania State College. A lever is provided at one end of each nozzle line, by means of which the entire line is easily turned. When in operation, the line is kept in one position until a strip of land has been sufficiently watered, and then the line is turned so the spray will fall on unwatered ground. It takes only a few seconds to turn each line and the attendant may be engaged in other

work, making the rounds of the pipe lines as often as may be necessary. If watering is attended to systematically, it is probably never desirable to apply more than an inch of water at a time. The numerous bulletins issued by the manufacturers of the drills, nozzles and unions give additional details concerning the installation and operation of this system.

CHAPTER IX

INSECT ENEMIES AND DISEASES

123. Importance of controlling garden pests.—The annual loss in the United States to vegetable crops from the depredations of insects and diseases amounts to millions of dollars. Practical growers, economic entomologists and plant pathologists believe that most of the losses could be forestalled by taking the proper preventive measures. In too many instances, however, the grower makes no preparation for control and when the pests appear it is impossible to secure a spraying outfit and materials before great damage has been done.

124. Preventive measures.—In the control of fungous diseases and insect pests of the garden, preventive measures are of prime importance. Spraying is often necessary, but it is expensive and should not be employed ordinarily until all other practical means of prevention have failed. Single cropping or the want of proper rotation frequently causes trouble. When a crop pays unusually well, the temptation is to continue its cultivation upon the same ground for years—a practice which harbors insects and diseases.

Diseased or infested seed or stock often introduce enemies. This is a strong argument in favor of the home production of seeds and plants. When plants are kept in a thrifty condition there is reduced danger of serious loss from both insects and diseases. Judicious fertilizing, cultivating and watering may be worth far more in warding off attacks than any amount of spraying. Infested soils when used in starting plants become a source of contamination. Too much care cannot be exercised in the selection of soil known to be free from disease germs.

The use of contaminated manure may also introduce diseases. Plowing and cultivating at just the right time often prove effective preventive measures; and clean tillage and the destruction of refuse after harvesting crops may be the means of avoiding serious losses.

125. Spraying.—Notwithstanding all general preventive measures, spraying is often necessary to avoid heavy damages. The fundamental principle involved is that of protection. If the operator uses an insecticide it serves as a poison or a repellent and should be applied before the enemy has made a serious attack; and if injury is expected from fungous diseases, by the application of a fungicide the parts in danger of infection are armored with material which will prevent the entrance of the parasites.

Five things are important in successful spraying: (1) Know your enemy; (2) select the most effective poison for its control; (3) spray thoroughly; (4) spray as often as may be necessary under existing conditions; (5) spray at the proper time.

126. Spray pumps.—Inexpensive pumps are seldom satisfactory. The best materials should be used in the construction of spray pumps; all metal parts which come in contact with the solutions should be made of brass or copper to prevent serious corrosion. A large air chamber is an advantage in securing an even and continuous discharge. Over 100 pounds pressure is essential to the best work in orchard spraying, but less than this is effective in garden operations.

Various types of pumps are available. The bucket pumps, which may be bought for a few dollars, answer the purpose in small home gardens. Knapsack sprayers are very convenient on small areas where the crops are planted close together, and in large plantations when growth is so far advanced as to prevent the use of barrel or power sprayers. It is not an easy task to carry and operate a knapsack sprayer, but it is unquestionably the

best pump under certain conditions. For example, aphides sometimes infest cabbage after the plants are too large to permit the use of barrel or power sprayers, and in addition, they colonize on the under sides of the leaves as well as on the upper. These conditions make the knapsack sprayer the most desirable pump for this work, especially if used with a crooked extension rod.

Barrel pumps are more satisfactory and less laborious to operate than knapsack sprayers, and are most popular with commercial growers. Chain and sprocket power machines are frequently employed. By their use large areas may be covered in a day. With a good pump and efficient nozzles properly placed and adjusted, the work is satisfactory. Gas, compressed air and gasoline engine pumps are not used extensively in commercial gardening. Various powder guns on the market are effective in the application of powders.

127. Nozzles.—For its value in spraying vegetables a nozzle depends upon its ability to break up solutions and mixtures into the finest particles. In orchard spraying and sometimes in garden treatment, an additional factor is important; namely, the ability of a nozzle to project the spray with the greatest possible force. The best known and most popular nozzles used by commercial vegetable growers are the "Vermorel" and the "Friend."

128. Insecticides.—Insecticides may be divided into three classes, namely: Stomach poisons, contact poisons and repellents. Stomach poisons are used in destroying insects with biting mouth parts; for example, the potato beetle and the asparagus beetle. Contact poisons are used in killing sucking insects, as aphides and the stink squash bug. Repellents, as lime and tobacco, may not kill insect foes, but they may be effective as deterrents.

129. Arsenate of lead is the most valuable of the arsenical poisons. It is a stomach poison and has three distinct advantages over other arsenical mixtures, which

are: (1) It is harmless to the foliage, (2) it adheres better to the foliage; (3) it remains longer in suspension. The usual strength is 3 pounds of lead arsenate to 50 gallons of water. Weaker mixtures are often effective, while 5 pounds to 50 gallons may be an advantage in killing insects difficult to poison. The commercial preparation which comes in the form of a paste should be mixed thoroughly with a small quantity of water before diluting in the sprayer. It may be used with bordeaux mixture without diminishing the value of either.

130. Paris green, a stomach poison which has been used extensively for many years in combating chewing insects. In order to prevent injury to foliage, it is always desirable to add some lime in the preparation of the spray. One pound of lime and one pound of paris green are used with 75 to 200 gallons of water, depending upon the susceptibility of the foliage to burning. It is always safer to have a slight excess of lime in the mixture. The paris green becomes more thoroughly diffused in the water if it is first mixed to a paste. As it is simply held in suspension and as it sinks quickly, the spray pump should be provided with an agitator to keep the mixture constantly stirred while being applied.

131. Hellebore.—White hellebore finds favor among some home gardeners mainly because it soon loses its poisonous principle when exposed to the air. As a stomach poison it is effective for cabbage worms and other pests, if the material is fresh when applied. It may be used as a powder, but the distribution is more thorough if applied as a spray, using $\frac{1}{2}$ to 2 ounces of powder in 2 gallons of water.

132. Kerosene emulsion is probably the most extensively used of contact poisons for sucking insects. It is prepared as follows: Dissolve $\frac{1}{2}$ pound of hard, soft or whale-oil soap in a gallon of hot water; while hot, add 2 gallons of kerosene. Then use a force pump provided

with a direct nozzle to churn or agitate violently for 5 or 10 minutes, or until the mixture is of the consistency of thick cream. If thoroughly emulsified the oil will not separate and the stock solution may be kept almost indefinitely. Dilutions, ranging from 10 to 20 parts of water, with one of the stock solution, are used for various sucking insects. It is essential, of course, that the emulsion come in contact with the enemy. This is not always easy to accomplish, especially when the insects are on the undersides of the leaves.

133. Carbolic acid emulsion.—As a contact poison and a repellent carbolic acid emulsion is valuable in combating root maggots of various crops, such as onion, radish and cabbage. It is made in the same manner as kerosene emulsion (132), by using 1 pound of soap, 1 gallon of water and 1 pint of crude carbolic acid.

134. Tobacco is used in various forms. The powder is often effective in destroying plant lice. Stems are sometimes strewn along the lines of peas to repel the pea louse. Tobacco decoction, made by steeping or soaking the stems in water, is an excellent insecticide for plant lice. Numerous nicotine extracts and powders have been placed on the market and are used for the various species of aphides.

135. Soaps.—Whale-oil soap, 1 pound dissolved in 5 to 7 gallons of water, makes a useful insecticide to control aphides and other minute insects. Hard and soft soaps may be substituted, but whale-oil soap makes a more effective spray.

136. Miscellaneous insecticides.—Numerous other materials are sometimes used in arresting the ravages of injurious insects. Lime, ashes, bordeaux mixture and sulphur may be classed among insect repellents. A formalin solution prepared by mixing 1 pint of a 40 per cent solution with 30 to 40 gallons of water is valuable in treating potatoes both for scab

and the potato scab gnat. Both cold and hot water are used in destroying plant lice, but hot water is far more effective. Plants will stand water heated to temperatures ranging from 125 to 180 degrees. The hot water treatment is especially desirable to check lice on a small number of cabbage plants in the home garden. Pyrethrum or insect powder is also effectual in destroying some insects by closing their breathing pores. It is generally used as a powder, but may also be mixed with water and applied as a spray.

137. Bordeaux mixture.—Although other fungicides are used sometimes in vegetable gardening, this is the standard spray for the control of fungus diseases of vegetables. The usual formula is: 4 pounds of lime, 4 pounds of copper sulphate (bluestone) and 50 gallons of water.

It is convenient to keep stock solutions of both the bluestone and the lime. To make a stock solution of bluestone, use 2 pounds of bluestone to the gallon of water. The lime should be slaked and kept as a thin paste. Both solutions should be covered to prevent evaporation. For the formula stated, add 2 gallons of the bluestone solution to 25 gallons of water and then introduce the lime paste diluted with the other 25 gallons. When insufficient lime is used there is danger of burning the foliage of many plants. To make certain of adding enough lime the ferrocyanide test should be employed. This may be done as follows: Dissolve an ounce of potassium ferrocyanide or yellow prussiate of potash in a pint of water; place in a bottle and label "poison." Stir lime solution into the diluted bordeaux mixture until the ferrocyanide solution will not turn brown when a drop or two is added from the bottle. It is always safer to have an excess of lime. As bordeaux mixture deteriorates upon standing, it should be used promptly after mixing.

138. "Sticker" or adhesive.—It is difficult to cause solutions or mixtures to adhere to the leaves of some plants; for example, the onion and cabbage. To obviate this trouble, a "sticker" may be made of 2 pounds of resin, 1 pound of sal soda crystals and 1 gallon of water. This mixture is boiled out of doors from 1 to 1½ hours, or until the solution is of a clear brown color, and then added to every 50 gallons of bordeaux mixture and to every 100 gallons of other spray materials.

CHAPTER X

SEEDS AND SEED GROWING

139. Importance of planting good seed.—Complete success in vegetable gardening is not possible without good seed. The planting of good seed is one of the essentials, and is just as important as proper soil texture, high fertility, frequent tillage, skillful watering or thorough spraying. Henderson states ("Gardening for Profit," p. 89): "If there is one thing of paramount importance in vegetable gardening it is purity of seed." He spoke from the experience of a long and active life as a practical commercial grower. Expert gardeners have always exercised great care in procuring good seed, although the significance of the subject has not been fully appreciated until recently. Good seed must meet five requirements: (1) It must be true to name and not mixed. The Matchless tomato may be as valuable for certain conditions as the Stone, but no dealer is justified in making the substitution without the consent of the purchaser. Turnip seed resembles cauliflower seed, but the dealer who mixes the two is a rogue. (2) The seed must produce the best type of the variety in question. Varietal deviations are marked; strains of the same variety differ widely in size, color, form, texture and quality of their products. The strain is by far the most important factor for consideration in obtaining seeds, although it has received comparatively little attention. (3) The seeds must be viable. That is, a high percentage should be able to grow under favorable conditions. (4) They must be free from weed seeds. This is seldom a source of trouble with garden seeds. (5) They must be free from impurities, as grit, sticks or other foreign materials.

140. Breeding and selection.—Rawson says (“Success in Market Gardening,” p. 57): “Perhaps we might truthfully say that the most important of all points in gardening is the right selection of seed; for without good seed the care and expense devoted to selecting and fitting the land, or procuring and using implements, fertilizers, etc., are all bestowed in vain.”

It is easily possible, however, to select seeds for years without making any advancement. This actually happened in the experience of Livingstone. For 15 years he labored in vain, eager to improve all varieties, but no progress was made, because wrong methods were employed; the largest and finest specimens of tomatoes were selected, year after year, with little or no regard for the plant. Then the plant instead of the individual tomato was made the unit, and Livingstone soon became a prolific producer of important varieties; no other man has accomplished so much for the improvement of the tomato.

The securing of good seed is not so much a question of selection as it is of careful and intelligent breeding. Starting with the plant as the unit, the grower must decide what he wants and what his market demands; for he himself might be very well satisfied, and his market very much dissatisfied. Suppose he is growing tomatoes and the plants are yielding well, but the fruits are generally rough and ill-formed, and yet, in looking over the field a few plants may be found which are highly prolific, and also produce better-shaped fruit than the hundreds or thousands of other plants growing under the same conditions. Seed should be saved from each of these plants, kept separately in numbered packets, and the next year the plants from each lot of seed set in different rows or plats. One of the selected plants may possess greater power to perpetuate its good qualities than any other, but this important discovery cannot be made if the seed from these plants be mixed.

This method of procedure is just as important with every other vegetable. The grower who wants better seed must have well-defined ideas before attempting any work of breeding or selection. If the cantaloupes are too coarsely netted, select for fineness of markings; if the cabbage lacks uniformity in time of ripening, select with this in view; if the onions are too flat, deepen the bulbs by selecting with this idea prevailing. Many other illustrations might be given. By intelligent selection it is possible to make improvements in size, color, form, flavor, texture, number of seeds, habit of growth, resistance to drouth, cold, heat and disease. Many valuable new varieties have been developed by the method indicated. The purpose of this chapter, however, is not to encourage the creation of new varieties, important though this may be, but to assist growers in the betterment of old varieties.

141. Commercial seed growing.—In the early days small lots of seed were kept for sale at grocery stores. As the population increased, and farming and gardening became more important, seed supply houses were organized. The first houses were established in this country about 1820, and the first catalogs printed soon afterward. Numerous houses have been started in all of the large cities and some of them have become mammoth establishments.

The seed business is highly specialized, requiring the service of experts who understand the principles of plant breeding. Much greater care and skill are exercised by some firms than by others; the most reliable maintain extensive trial grounds, where the seeds are tested before being sold. It is a means of protecting both the dealer and the buyer.

Two methods are pursued by dealers in securing the seed required for their trade. Most large firms own land on which certain seeds are grown under their direct management. It is usual to charge higher prices for such

seed than for that grown by contract, the method under which the bulk of garden seeds is grown. In the contract method, when a house needs a certain quantity of seed, say Jersey Wakefield cabbage, a contract is made with a grower who produces seed of this variety, and who may also furnish seed to many other houses. As this grower probably owns very little land, it is impossible for him to grow all of his seed, and, therefore, he must contract with a large number of other gardeners or farmers to grow the supply for him.

In the management of seed growing by contract, various methods are employed. In many instances stock seed is furnished to the grower by the seed house or by the man with whom the grower has contracted. This stock seed is supposed to be carefully bred and grown under the direct management of experts. In the production of high-grade seed, one of the most important factors is furnishing the best stock seed to the grower. The stock seed is sometimes furnished free to the grower, but the usual practice is to make a charge, which may be paid when the seed is obtained before planting, or it may be deducted from the value of the seeds grown.

Many intelligent and reliable growers do not depend upon a middle dealer or a grower, or upon a seed house, for their stock seed. They have established a reputation for well-bred seeds, and can often demand higher prices than growers who are furnished stock seed.

The greater part of the seeds sold in the United States is grown in this country, although there are many exceptions. The chapter on the culture of the various classes of vegetables gives additional information upon this subject.

Seeds are grown on an extensive scale where natural conditions are most favorable; soil, climate and the cost of labor are all important factors. Many crops, as the cauliflower, cabbage and pea, thrive best in a cool climate

and, therefore, these seeds are grown to the best advantage in the North. On the other hand, as watermelons must have plenty of heat and sunshine, we find that Georgia conditions are ideal for this crop and the growing of good seed; pepper and eggplant seeds may be grown in the cold parts of the North with success, but for large yields of plump seeds the warm, sandy soils of New Jersey furnish ideal conditions; lima beans are grown in California because soil and climatic conditions are favorable to the best crops; the Puget Sound district furnishes splendid conditions for growing cauliflower seed. Many other examples might be given. Some seeds are grown almost entirely in foreign countries because of cheaper labor.

One of the most important operations in growing high-grade seeds is "roguing." A "rogue" is a plant that is off type, and should not be allowed to produce seed. The discarding of such plants is called "roguing," and the quality of the seed from the standpoint of uniformity in the ultimate crop depends mainly upon the thoroughness of this operation. It is absolutely necessary for some one who knows the true or most desirable type to inspect every plant before it is allowed to produce seed. This is the step in the production of seeds for the large commercial houses which needs the most improvement. Roguing is generally practiced, but in too many cases it is not sufficiently severe. The right soil and climate cannot do everything. Scientifically conducted breeding plats and rigid roguing are the two greatest needs of American seed farms.

142. Growing seeds at home.—It is claimed by many that it does not pay commercial gardeners to grow their own seeds. It is argued that seeds may be purchased from commercial houses at less cost than they can be grown at home; that home growing is troublesome; that gardeners do not have time to give the matter proper

attention; that facilities for harvesting and cleaning are usually meager; and that most gardeners do not possess the necessary knowledge to grow good seed.

There is much truth in all of these arguments; notwithstanding, many expert gardeners grow a large percentage of their seeds. These men hold that they cannot afford to take chances in buying seeds; that they know the requirements of their markets and can select seed with this knowledge in view, together with other qualities which they regard important; that although their soil and climate may not be ideal for seed production, skillful breeding may produce better seed than is procurable on the market. In diversified gardening it is seldom practicable to save many seeds, but where only a few special crops are grown it is often highly desirable. Most of the seeds used in vegetable gardening will always be supplied by great seed houses, although there will probably be an increased tendency among specialists to grow their own seeds.

143. Harvesting, cleaning and curing.—Various methods are pursued in the harvesting and cleaning of garden seeds, and further instructions are given in the chapter devoted to the various classes of vegetables.

Seeds should not be harvested until fully ripe or mature. While this is true, it is equally important to be prompt in gathering the crop when the proper time has arrived. If sprouting or molding does not occur, the seeds will discolor if left too long on the stalk, and this is always objectionable when they are wanted for commercial purposes. Seeds are generally ripe when the pods or seed capsules turn yellow, or the fruits, as tomatoes and melons, lose their firmness.

Bright, sunny weather should be selected, if possible, for the harvesting of crops which require threshing. The plants should be thoroughly dried before threshing, and it is always better to select days of low humidity for this operation. Whatever the method, whether by flailing or

by machines, the greatest care should be exercised to prevent breaking the seeds or the seed coats. Windmilling is necessary for further cleaning of the seed.

In securing clean seeds, vegetables such as tomatoes and melons must stand for some time in their juices to remove the mucilaginous covering. A common method is to throw the cut or broken specimens, or sometimes the pulp, into any convenient vessel, as a crock, tub or barrel, and stir daily until fermentation has loosened the covering about each seed. Then the operation may be completed by washing. To prevent the discoloring of seeds, the fermentative process should not be continued longer than necessary.

After fermentation, the seeds are separated from the pulp and the skin by washing as often as may be required to obtain clean seeds. The good seeds settle to the bottom of the vessel, while pulp, skin and light seeds rise to the top, and may be poured off. Three or four washings are usually sufficient. Sieves are often used in the process of separation by washing.

After windmilling or washing the seeds must be thoroughly cured before storing. They should be spread in thin layers in lofts, or in dry, well-ventilated places until thoroughly cured. It is an advantage to wash early in the morning of bright days to facilitate drying. Seeds must not be subjected to freezing temperatures before being cured, for this invariably impairs their germinating power.

144. Preservation of seeds.—Seeds may be stored in either cloth or paper bags. The greatest enemy to the preservation of seeds is moisture, but the conditions in an ordinary living room are satisfactory, although neither high nor low temperatures affect the vitality, provided the seeds are well cured and the humidity is low. It is a well-known fact that seeds do not keep well in the South, because of the great amount of moisture in the air. The

hot weather also hastens deterioration. Some seeds, as that of turnip, cabbage and radish, may mold unless kept in well-ventilated bags.

145. Buying seeds.—Buy the best; the price is secondary. It costs much more to produce good seeds than poor, because the time of experts and the most severe roguing are required. For example, certain well-bred strains of Jersey Wakefield cabbage tested at the Pennsylvania State College were found to be much more profitable than others. (Pa. Sta. Bul. 96.) The expenditure of a few more dollars a pound for seed is not worth considering when there is assurance of increased profits.

Buy from reputable houses; they desire to serve you well. All good seed houses have specialties in which they take great pride, and it often pays to patronize these houses when such varieties are wanted. Special commercial growers sometimes purchase, a year in advance, liberal quantities of the same variety from different houses. Each lot is then tested and the best is used for the regular plantings the following year.

146. Seed guarantees.—Several states have enacted laws to regulate the seed trade. Such laws have doubtless been valuable, but it is an extremely difficult matter to control by law. Legislation is needed more for farm seeds than for garden seeds, as impurities are seldom found in vegetable seeds. Many firms are making an honest effort to sell good seed, but errors in labeling may occur, and inclement weather may affect the vitality of seeds, and unjust penalties might be imposed if legislation were too severe in this matter. There are humbugs in the seed business, but why should they be patronized when there are so many reputable dealers, although even the most reliable dealers may make mistakes?

147. Change of seed.—There is a prevailing idea that growers should change seed after using the same strain for a few years. If the seed is selected at home without

care or intelligence, this advice is in order. On the other hand, if the fundamental principles of breeding are observed, why should it be necessary to discontinue a strain of merit for one of unknown value? A change of variety is a different proposition and this can often be done to advantage.

148. Novelties.—All good varieties now in cultivation were once novelties. Advancement has been possible because novelties arouse universal interest, although comparatively few of them ever become of great value. The grower, however, never knows when a novelty may become more valuable than an old variety he has been growing perhaps for many years. The testing of novelties, then, is of economic value. The producer who is specializing in only a few important vegetables can well afford to test the novelties. One of superior merit might materially increase profits if substituted for a long cultivated variety. A sample packet of seeds is sufficient to test a novelty and therefore the expense is slight, while the reward may be great.

149. Old versus new seed.—Fresh seed usually germinates more promptly than old seed, although there may be advantages in sowing old seeds. Many gardeners claim that fresh seed of the cucurbits (melons, cucumbers, squashes, etc.) tends to produce more vine and leaf and less fruit than seed several years old. But fresh seed is generally preferred and is particularly important when the vitality of the seed is low, as with onion and parsnip.

150. Seed testing.—Seeds may be tested to determine their purity, trueness to name or type and their viability or power to grow. As most garden seeds do not contain impurities, testing for this purpose is of little importance, while testing for trueness to name or type is of great importance, and can be done to a considerable extent by special growers who are cultivating only a few crops. Most of the testing at the experiment stations has been

done to determine the sprouting or germinating qualities of garden seeds. Sprouting tests are made in plates, pans, dishes and in various apparatus where soil and moisture conditions may be controlled to a greater or less degree. Gardeners want to know whether their seeds will grow when planted under real conditions, and germination tests are regarded more valuable by practical growers when carried on under natural conditions. Seeds are counted in lots of 25, 50, or better 100, and planted in drills. The soil should be in good physical condition and watered often enough to keep it moist. When sufficient time has been allowed for germination, the plants in each row are counted and the percentage determined. Such a test may be the means of avoiding losses and disappointments by sowing seed of low germinating power. It requires very little time, and it is a great satisfaction to make the main planting with the assurance that a high percentage of the seed will grow. Most of the large seed houses test the germinating power of their seeds before supplying customers.

Rules and regulations for official seed testing, adopted by the standing committee on methods of seed testing of the Association of American Colleges and Experiment Stations, are published in Circular 34 of the Office of Experiment Stations.

The following table shows about the average percentages of germination of one-year-old seed when planted under proper conditions:

Asparagus	90	Okra	80
Bean	90	Onion	80
Beet	140*	Parsley	70
Cabbage	90	Parsnip	70
Carrot	80	Pea	90
Cauliflower	80	Radish	90
Celery	60	Salsify	75
Corn, sweet	85	Spinach	80
Cucumber	85	Squash	85
Eggplant	75	Tomato	85
Lettuce	85	Watermelon	85
Muskmelon	85		

*Botanically a fruit, often containing more than one seed.

151. **The longevity of seeds.**—The life of seeds depends upon (1) the kind of vegetables, (2) conditions under which they were grown, (3) thoroughness of curing and (4) storage conditions. In some years seeds lose their vitality more rapidly than in others. The figures in the following table relative to the longevity of vegetable seeds are conservative, for it is not best to place too much reliance upon tables of this character; the only certain means of determining the vitality of seeds is to make germination tests.

The following table shows maximum ages of properly cured and stored vegetable seeds when they will be likely to germinate satisfactorily:

	Years		Years
Artichoke	2	Lettuce	4
Asparagus	2	Muskmelon,	5
Bean	3	Okra	4
Beet	4	Onion	1
Cabbage	3	Parsley	1
Carrot	1	Parsnip	1
Canliflower	4	Pea	3
Celery	2	Pepper	3
Cucumber	5	Radish	2
Eggplant	5	Salsify	2
Endive	2	Squash	3
Kale	2	Tomato	5
Kohlrabi	3	Turnip	4
Leek	3	Watermelon	5

CHAPTER XI

CONSTRUCTION OF HOTBEDS

152. The necessity of glass.—In nearly all types of vegetable gardening glass is essential to secure the best returns. It is true that many crops, as sweet corn, cabbage, peas, beans and the root crops, are grown at a profit without the use of glass, although most gardeners regard it as indispensable for certain parts of their operations. The term glass includes the different types of hotbeds, cold frames, forcing hills and greenhouses.

Glass is often used merely for protection, as for wintering plants in cold frames. The more common uses, however, are to hasten or forward the growth of plants, so the crops will mature before their normal time, and to grow crops to full maturity during the winter season, when it is not possible to produce them in the open in the same latitude.

There are many advantages in starting certain vegetables under glass, then transplanting to the open ground as soon as conditions are right. Some of these advantages are: (1) Crops placed on the market before their normal season usually command the highest prices. (2) In many sections the summers are too short to mature certain crops, such as eggplants, watermelons and late tomatoes, without the use of glass. (3) In starting the crop early there is less danger of loss by destructive frosts in the fall. (4) By forwarding the plants under glass, two or more crops can often be grown on the same land during the season. (5) Weeds are generally less difficult to combat when plants of good size are set in the open. (6) It may also be the means of avoiding troublesome insects and fungous diseases. (7) Some vegetables,

notably the tomato, produce larger crops when started under glass. (8) As the vegetables will be harvested considerably earlier, there may be time to start a cover crop. This is of great advantage in soils lacking humus.

153. The extent used.—Before greenhouses became so popular as they are today, hotbeds were universally employed whenever glass was required to start early plants. Although hotbeds, in many cases, have been replaced by greenhouses, they are still used extensively by growers in all parts of the country. Almost every farm home operates a hotbed in the spring. This structure is of great importance to village gardeners who pride themselves upon the earliness of their products. Many renters also depend upon hotbeds, because they may be forced to vacate the property upon short notice and are naturally unwilling to spend much money in constructing permanent greenhouses. Hotbeds are inexpensive, and the amount of space devoted to them may be increased from year to year without much outlay. In addition, they do not require attention at night, as do the furnaces of greenhouses. On the other hand, hotbeds are inferior to greenhouses in every particular, although with skillful management they produce excellent results.

154. Location and arrangement.—Hotbeds should be located so that a liberal supply of water is accessible. The most convenient plan so far as water is concerned is to install the overhead system of irrigation (122) and also to make provision for hose connections. Spigots, with underground cut-offs, should be placed between the frames, at intervals not exceeding 100 feet.

The hotbeds should also be convenient to the farm buildings, and to a room which can be made warm and comfortable for the work of sowing and transplanting. The frames require frequent attention some days, and a convenient location is important for this reason.

Protection from severe north and west winds is a great

advantage. This may be secured by natural windbreaks, as hills and trees. Buildings may also serve the purpose. A common practice is to plant hedges or to construct board walls 5 or 6 feet high for this purpose. The walls may also be used to support the mats while drying.

South or southeastern exposures are preferable to others. The frames should run parallel with each other, with ample space between them for alleys or roadways, for the handling of mats and sash, and for snow shoveled from the glass. To serve these purposes best there should be at least 10 feet between the frames, but when the land is high priced and limited in area it is economy to make the alleys about 2 feet wide. These alleys are often filled with manure to help retain the heat of the hotbeds.

155. The pit.—Most hotbeds are heated by the fermentation of manures in pits excavated for this purpose. The first essential of the pit is good drainage, natural or artificial. Artificial drainage may be provided by running tile from the bottom of the pit. In most soils, however, this precaution is unnecessary. The pit should be dug in the fall before the ground is frozen, and a few inches of leaves or coarse manure placed in the bottom during the winter. It should be of the same width as the frame (156) and of any desired length.

The proper depth of the pit depends upon several factors. In the North it is customary to use 15 to 30 inches of manure. The pit should, therefore, be a few inches deeper than the depth of the manure. For starting early vegetable plants in the North, 18 inches of good manure is ample, while 24 to 30 would not be too much in forwarding the eggplant, which requires a high temperature for seven or eight weeks. Tender plants, like tomato and pepper, also require more manure. Southward, the depths of manure vary from 6 to 12 inches. The kind of manure used and the length of time the hotbed will be needed also determine the proper depth of the pit.

156. **The frame.**—The frame may be made of wood, concrete, brick or stone. The most common material is wood, although concrete is more durable. Of the woods, locust, cedar and chestnut make the most durable frames. A common plan is to use either locust or cedar for the posts, and chestnut or other less durable woods for the sides and crossbars. The frame may be of any desired length, and wide enough to accommodate the sash. That is, the width of the frame at the top should be about $\frac{1}{2}$ inch less than the length of the sash.

The upper or north side of the frame should be 6 inches higher than the lower or south side, in order to give the proper slope. This can be easily accomplished by using boards of 6 and 12-inch widths. Usually one 6-inch and two 12-inch boards or planks are sufficient for the upper side of the pit, and two 12-inch pieces for the lower side: the boards should always extend to the bottom of the pit. The posts should be made of 2x4-inch lumber, or heavier. It is usually necessary to remove some soil at the sides of the pit where the posts are to be placed. The best frame will be made if the boards are not more than 12 feet long, and posts driven at the ends and midway between.

Crossbars or slides are not always provided, but they possess so many advantages that frames should seldom be made without them. A 2x3-inch piece is about the right size, and should be sound and surfaced on the upper side. Some gardeners prefer a $\frac{1}{2}$ -inch strip in the middle of each crosspiece to prevent binding of the sash—a provision that is well worth while making. The sash can then be handled with much less annoyance.

When placing the crossbars, great care should be exercised, for if they are too close together the sash will bind and greatly annoy the attendant. If the sash are 3 feet wide, the distance from center to center of the crossbars should be at least $\frac{1}{2}$ inch more than 3 feet.

157. **Sash.**—The most durable wood should be used in making hotbed and cold frame sash. Cedar or cypress is usually employed. Many of the old sash now in use were made of white pine. However, it is a mistake to have sash made of the softer woods at local factories which do not make a specialty of this line of work. Sash differ



FIG. 19. SASH FOR HOTBED OR COLD FRAME

greatly in width and length, but the standard and most popular size is 3 x 6 feet. Longer sash require wide frames which are inconvenient in the daily care of the plants. Sash vary also in thickness; 2-inch lumber when dressed makes a very strong sash, but it is more common to use 1½-inch lumber, which planes down to 1⅜. The

lighter sash are easier to handle, while the heavier ones sustain less breakage from hard winds.

Before purchasing sash, inquiry should be made regarding the type of construction. The joints should always be leaded before the parts are put together, and less moisture will be absorbed in the corners if the tenons do not extend through the side-bars. A light iron rod across the middle of the bars strengthens the sash and prevents spreading. (See Figure 19.)

A priming coat of paint should be applied before glazing. It is always desirable to buy glass of good quality, although the cheaper grades are often used for this purpose. Some gardeners prefer to butt the glass. When this is done, grooves are cut in the sides of the sash-bars in which the glass slides; but unless the ends of the panes fit very closely there will be considerable leakage, for which reason lapping is more popular. The glass need not lap more than $\frac{1}{8}$ inch. A 3 x 6-foot sash is usually made for three runs of 10 x 12-inch glass, requiring 18 panes for each sash. The glass is fastened by glazing points, and the putty or mastic is applied in the angles formed by the glass and the sash-bars. A better plan, although more tedious, is to lay the glass in putty. After glazing, the sash should again be painted, and the work repeated every year thereafter. When not in use they should be stored in the dry, or stacked. In the latter case several of the upper sash should be nailed together with vertical strips to prevent the wind from lifting and breaking them. If the glazing is done at home and glass bought in wholesale lots, the sash can be made in lots of 50 or more at a cost not exceeding \$2.25 each.

Double-glass sash are also on the market. These possess advantages and also disadvantages. The advantages are: (1) Plants are afforded almost as thorough protection as with single glass covered with rye-straw mats, and in many parts of the country double sash

should give all the protection needed by plants ordinarily grown in frames. (2) The labor in the management of the frames is reduced, because there are no mats to be handled morning and evening. (3) The plants receive the light during the entire day, because there are no mats at any time to obstruct it. (4) A growing temperature is reached earlier in the day, and is maintained longer, unless there is little or no sunshine.

Disadvantages that may be mentioned are: (1) Double-glass sash are much heavier to handle, and this is one of the greatest objections raised by men who handle sash by the hundreds. (2) They cost about one-third more. (3) On account of the accumulation and retention of moisture between the two layers of glass, it is thought that the sash will not be so durable as single-glass sash. (4) The two layers of glass and the accumulation of dirt and moisture between the panes reduce the amount of light entering the frames, and in consequence produce weaker plants. This new type of sash can be used to advantage for many purposes, although the single-glass type will doubtless continue to be popular in sections where hotbeds are used extensively. Oiled paper and special waterproof cloth are substituted for glass sometimes. Although less expensive, they lack durability and do not generally give as satisfactory results as glass sash.

158. Manure and its preparation.—Practically all manure hotbeds are made with horse manure. Poultry and sheep manures are also desirable, although they are too valuable in fertilizing garden crops to be used for this purpose. Spent hops from breweries, and forest leaves, may also be worked into the hotbed manure, which should be fresh and not too compact nor too loose. If it is composed almost entirely of the solid excrements of the horse, with whatever urine it has absorbed, it may fail to heat, or the fermentation may be too violent and of too short duration. Two parts of excrement to one

part of litter give satisfactory results. If too rich, forest leaves may be added. Manure with shavings as the litter is never satisfactory. The manure from horses well fed on grain is the best for hotbed use.

Preparation of the manure should begin 10 or 12 days before the time when the beds will be wanted for seed sowing or transplanting. A stable or a protected shed is necessary in preparing the manure for the best results in cold weather, because hard rains and severe weather may hinder or prevent fermentation.

Fresh manure from city livery stables, shipped on cars or barges, is often in proper condition for the pit when received, although piling and turning are usually necessary. The piles should be 4 or 5 feet wide, about 4 feet high and of any convenient length. When the manure is thrown from the wagon it should be tramped, but not too compactly. If the manure is rather dry, the addition of hot water will help to start fermentation. Ordinarily, the pile will begin to steam in a day or two. When fermentation is well under way, restack, placing the exterior of the pile on the interior of the new pile. After the manure is allowed to remain in this condition two or three days, or until the entire mass is hot, the pit should then be filled.

159. Filling the pit.—The manure should be thrown into the pit in successive layers of 5 or 6 inches and tramped firmly, especially along the sides and in the corners of the frames. The manure will settle several inches, and allowance should be made for this when filling. After the manure is in, from 4 to 6 inches of good soil is placed on the manure. Two inches of soil is sufficient covering to absorb steam and to keep the air pure if flats are used instead of sowing or planting directly in the soil. The frame is also banked with manure.

160. Other types of manure hotbeds.—The pit is sometimes dug a foot wider than the frame is to be and not

lined with boards, as previously described (156). Portable frames are placed on top of the manure, which is about even with the surface of the ground, and the frames are then banked with manure. This plan requires more manure, although the beds furnish heat for a longer period, and they settle with the manure, and so the plants are always the same distance from the glass. Another plan often used southward and on poorly drained land is to place the manure on top of the ground, and in this way dispense with the pit. This requires more manure than either of the plans described, because there is no protection at sides and ends. Liberal space must be

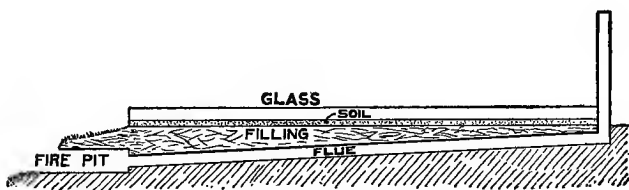

FIG. 20. FLUE-HEATED FRAME

provided for banking the frame when it is placed so high above ground. Manure greenhouses are sometimes used by placing hot manure under the benches; a central alley is provided, so it is possible to work in the house with the same convenience as in houses heated by flues, steam or hot water. The plan is not recommended, because steam or hot water heating is more economical and much more satisfactory.

The manure from spent hotbeds has lost most of the nitrogen, but it is useful for composting and fertilizing crops which do not require large amounts of this element. It is also useful for placing in the bottom of flats before transplanting.

161. Heating frames by the use of flues.—Many growers heat their frames by a system of flues leading from a furnace burning wood or coal. The plan is regarded as more economical than the hotbed method, and the results, with proper management, are equally satisfactory. The furnace or fire box at one end of the frame is cheaply constructed, and should be 3 or 4 feet long, and about 18 inches square, with provision for an ash pit under the grate bars. A main flue is built from the fire box, extending 8 or 10 feet under the soil of the frame, where it

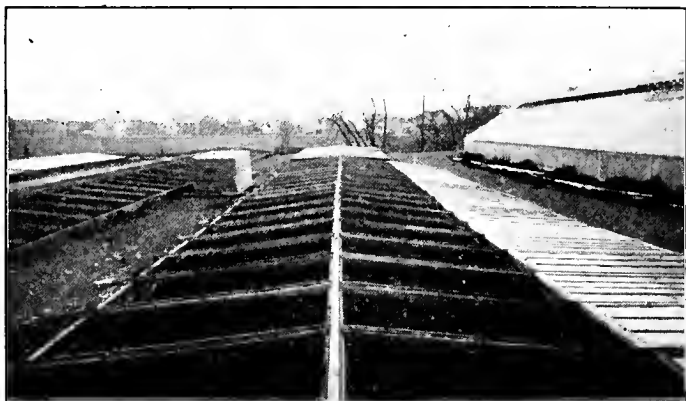

FIG. 21. STEAM-HEATED FRAME

separates into two smaller flues that continue almost to the other end of the frame, which may be at least 60 feet long, before they join again and enter a chimney. Figure 20 shows this system of heating, but in a different form of construction. The flues may be made of brick, stone or tile, and may vary from 6 to 12 inches in size. Ten-inch tile are very satisfactory. Near the furnace the flue should be about 3 feet under the surface, rising gradually to 1 foot at the chimney. The air in the flue-heated

frames has a tendency to become very dry. To prevent this, pans of water should be kept in the frames. Sheds may be built at the furnace end of the frames, to provide comfortable quarters for the work of seed sowing and transplanting.

162. Heating with steam and hot water.—A frame piped and heated by steam is shown in Figure 21. Hot water may be used in the same way. When heated by either method, mats may be dispensed with. The principles of steam or hot water heating must be observed to secure satisfactory results. These systems of heating are becoming more popular every year. Drain or sewer tile may also be laid in the soil of the frames, steam being conducted through them under some pressure.

163. The uses of hotbeds.—Hotbeds are used for starting early vegetable plants. The seedlings are started in the hotbeds and transplanted into other hotbeds, cold frames or the field. Hotbeds are also used in forcing some crops to maturity. The most popular vegetables for hotbed forcing are radishes and lettuce. Spring and summer crops are frequently matured in hotbeds, being started over the fermenting manure, or over manure whose heating qualities have been exhausted. Among the crops grown in this manner are cucumber, muskmelon, eggplant, squash, tomato, cauliflower, kale, spinach, radish and lettuce.

CHAPTER XII

CONSTRUCTION OF COLD FRAMES

164. **Location and arrangement.**—Cold frames are generally used without artificial heat. It is important that they be well sheltered from north and west winds. As a rule they are used later in the spring than hotbeds. The water requirements of the plants are therefore greater, hence the facilities for watering should be as convenient as possible. Spigots should be located so all the plants

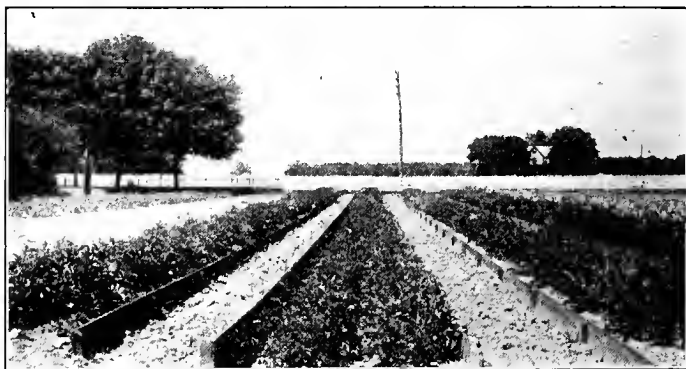

FIG. 22. POTATOES IN COLD FRAME PLAT. SUMMER CULTURE

can be reached with hose and nozzles. If the cold frame plat is extensive, it will pay to install a line of Skinner irrigation in each frame. The pipe may be placed on the upper side of the frame under the crossbars, with the greenhouse type of nozzle provided at intervals of 3 feet (122). This is a great labor-saving device in the management of frames, and makes it possible to water more

uniformly than can be done with hose or watering can. The suggestions on the location and management of hotbeds apply equally well to cold frames.

165. Grading.—If the ground is uneven or sloping, it should be graded before placing or making the frames. Level ground is important for effective watering. When, for example, flats do not set level in the frames, much of the water applied with a hose will run off before it has time to percolate. This may also be true of solid beds, especially if the soil is clayey and lacking in vegetable



FIG. 23. PEPPERS IN COLD FRAMES. SUMMER CULTURE

matter. Excavation is not required for cold frames, as they are mostly placed on top of the ground and banked with some material that will afford additional protection.

166. The frame.—Cold frames are less expensive to make than hotbeds. Their construction is more economical in three particulars: (1) Excavation is not necessary when vegetable plants are grown. (2) Heating material is not needed. (3) The frame itself requires less material.

Many of the points made in considering the frame and sash for hotbeds apply equally well to cold frames. As

cold frames are placed on top of the ground, the sides do not need to be so high as for hotbeds, unless the hotbed frame is simply placed on top of the manure, in which case there would be no difference in this respect. The height of the sides, or, in other words, the depth of the frame, must be determined by the size of the plants to be grown. It takes a deeper frame to grow tomato plants than to mature a crop of forcing radishes. Ordinarily,

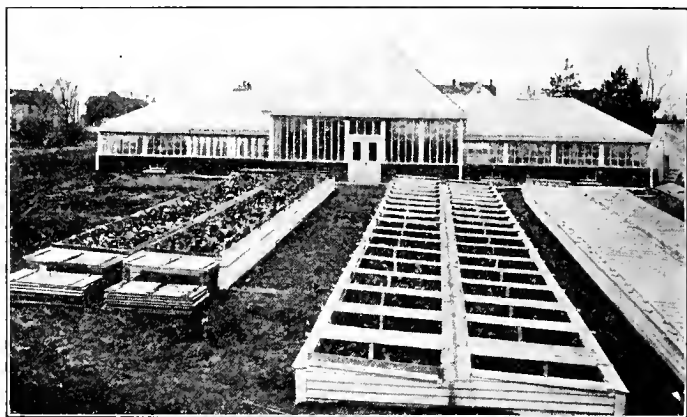

FIG. 24. PERMANENT COLD FRAMES

a 12-inch board or plank is high enough for the north side and a 6-inch piece for the south side. An additional depth of 2 to 4 inches is an advantage in some lines of work. If flats or plant boxes are to be used in growing cabbage and tomato plants, the frame at the north side should be 16 inches deep and at the south side 10 inches.

The frames may be movable or stationary. The most common plan is to nail the side boards, which should be not less than $1\frac{1}{2}$ inches thick, to stakes placed on the outside. Chestnut lumber, $1\frac{1}{2}$ -inch thick, makes very satisfac-

tory material for this purpose. The end boards, held in place by cleats or other devices, may be removed and the soil of the frame cultivated in the manner shown in Figures 22 and 23. The crossbars should be dovetailed in the side boards so they can be removed quickly.

While portable frames are often used, they are not popular with extensive commercial growers. Portable frames may be dovetailed at the corners or held together by rods and bolts. They are usually made to accom-



FIG. 25. CUCUMBERS IN COLD FRAME PLAT NEAR NORFOLK, VIRGINIA

modate either two or four 3 x 6-foot sash. A double frame in use at the Missouri Experiment Station is shown in Figure 24. The outside of frames when used in cold weather should be banked with soil, manure or sod. An excellent plan is to bank with soil and then sow grass seed on the slope, unless the alleys are to be cultivated during the summer.

167. **Soil of the cold frames.**—When the frames are used only in starting plants in flats, the character of the soil is not considered. If used without flats, the greatest

care should be exercised in preparing the proper soil. Unless the subsoil is brought to the surface, the land may be treated as for any other intensive garden work. Figure 25 shows plats of frame cucumbers at Norfolk, Va., with the side boards removed. The wide alleys will soon be completely covered with the cucumber vines.

168. Heating.—Cold frames are sometimes piped and heated with steam or hot water (162). They may then be used at any season, and with their use the grower can have good control of all conditions which count for success. It is a recognized fact, however, that heated frames are not so satisfactory as greenhouses.

169. The use of cold frames.—Cold frames are used to a far greater extent than hotbeds. Plants started in the greenhouse, hotbed or kitchen window are often transplanted into cold frames. This is perhaps their most common use. They are also employed extensively in the hardening of plants and in the forcing of fall and spring crops to maturity. Lettuce and radishes are especially popular for frame culture, while many other crops are often grown in cold frames. Many market gardeners own from 1,000 to 4,000 sash, and some growers confine their operations entirely to frame culture.

170. Forcing boxes.—There are various methods of making forcing boxes. The most common plan is to make a frame 10 to 12 inches square and 6 inches deep, and cover with a pane of glass. These frames are especially valuable in starting melons and other cucurbits in regions where the summers are too short and cool to grow a satisfactory crop without the aid of glass. The frame is placed over the hill after planting seed in the open, covered with glass, and ventilated when necessary. Hundreds of them are used by some gardeners.

CHAPTER XIII

CONSTRUCTION OF GREENHOUSES

171. Extent used.—Greenhouses are in far more general use among market gardeners than they were 10 or 15 years ago. They have become especially numerous near railroad lines affording satisfactory shipping facilities and large cities providing good markets for forced vegetables. When a grower learns that a greenhouse is a profitable investment the usual tendency is gradually to increase the area of glass, as many examples of such expansions will prove. The first house is perhaps very small and built for the purpose of starting early vegetable plants, for which it is found convenient and satisfactory; but the owner is often unwilling to have it idle more than half the year, and, therefore, he tries a forcing crop. If his efforts in the production of crops under glass prove successful, the greenhouse area is increased and new houses are built from year to year, until the grower is known as a vegetable forcer rather than a market gardener. The greenhouses furnish better conditions for starting early plants and they may be used 10 or 11 months in the year if the establishment is properly handled. It is not uncommon for market gardeners to operate an acre or two of greenhouse space, while a much larger proportion of growers have from 1,000 to 10,000 square feet of glass.

172. Advantages.—If forced vegetables can be made profitable in connection with market gardening, there should be no hesitation in constructing greenhouses. They enable the grower to keep in touch with the market the year round, and they provide employment in the winter when it is often difficult to find sufficient work to

keep men busy. Then, again, a greenhouse adds materially to the pleasures of rural or urban life, as it insures summer conditions the year round on some part of the place.

For starting early vegetable plants the greenhouse possesses decided advantages over the hotbed. These may be enumerated as follows: (1) It is cheaper to heat glass structures by means of coal than by manure. (2) Proper soil and atmospheric conditions are better controlled in greenhouses. The gardener spends much of his time inside of the house, and he has abundant opportunity to note every change. If the soil is too dry, it is detected before any injury has been sustained by the plants. If the air is too close, the grower soon discovers it, and the ventilators are opened. (3) Fresh air may be admitted in the severest weather without cold drafts striking the plants. This is impossible in hotbeds. (4) The daily care of greenhouses is less laborious and, therefore, less expensive than in the management of hotbeds. There are no sash to be handled separately several times a day, no mats to move twice a day and no sash to raise when watering. When the Skinner system of irrigation is used in the greenhouse, the labor of watering is so small as to be scarcely worth considering.

Greenhouses are employed for a variety of purposes by market gardeners besides that of forcing crops to maturity. The growing of seedlings for transplanting in cold frames is one of the largest uses. The more tender plants, as tomato, pepper and eggplant, are often transplanted $1\frac{1}{2}$ or 2 inches apart after the seedlings are three to five weeks old. If space permits, any of the vegetable plants may be kept in the greenhouse until time for planting in the open ground. If desirable, they may then be shifted to the cold frame for a short time to harden.

173. The size.—The proper size of a greenhouse must be determined by a number of factors. It is never a safe

policy to build a large house or an extensive range of houses without thorough experience in greenhouse work and full knowledge of local conditions and market facilities. A house 30 x 100 feet is probably as large as any market gardener should start with, and a smaller structure would be desirable where both capital and experience are limited. A width of 30 feet has been given, because this is the minimum width for economical construction, heating and operation; narrower houses do not provide as uniform atmospheric conditions, and the plants are more likely to be injured by direct cold drafts.

174. Location and position.—While the natural protection of woods or hills on the north and the west sides is highly desirable, greenhouses should not be constructed where they will be shaded by other buildings.

The position of the house with reference to the points of the compass is apparently of little importance. A three-quarter span house should run east and west to get the full benefit of the sun, while the even span house should probably run north and south in order to secure a uniform distribution of light. Some growers compromise and build their houses northeast and southwest. With the modern house, about 95 per cent of which is glass, ample light will enter the house whatever its position may be.

175. Materials used in construction.—Serviceability, durability, and economical construction and operation are the main points to keep in mind when building greenhouses. No one denies that the full iron form of construction is the most durable and that it is also highly satisfactory when in operation, but the cost of construction is beyond the means of most vegetable growers. Again, it is doubtful whether full iron construction is the most economical in the end; the first cost is from one-third to one-half greater than for semi-iron construction, and this additional expense may exceed the cost of re-

pairs in other types of construction. With proper care and painting the wood parts in a well-built house will last 25 years, and they could then be renewed at a cost which would not be burdensome to a grower who had harvested profitable crops for a quarter of a century. Iron pipe, concrete and thoroughly dried cypress are the most important materials needed in the construction of a modern commercial greenhouse.

176. Semi-iron type of construction.—This is by far the most popular form of construction. The walls are usually concrete, and the 2-inch pipe posts which support the roof of the house are often embedded in the concrete. If provision is made for walks or alleys along the walls in the greenhouse the posts should extend at least 6 feet 4 inches above the ground level. All purlins, braces and interior posts are made of iron pipes. The construction is of such a character that it is easily possible to replace decayed wood parts without disturbing the pipe posts, purlins or braces. Walks, beds and benches of concrete may be used if desired. Houses of this type are attractive, serviceable and durable. Any local carpenter can build them without difficulty, for nearly all wood parts are cut to the right dimensions at the factory and blue prints are furnished for the instruction of builders.

177. Forms of greenhouses.—Lean-to, side-hill, even-span and three-quarter span are the distinct forms of greenhouse construction. The lean-to house is the least expensive type to construct, and it is often highly satisfactory; but it is most useful when built as a lean-to against a building or wall running southeast and northwest, where there will be practically no shading of the plants. Lean-to houses are sometimes built along the south side of larger greenhouses. While simple in construction, they are not generally popular.

Side-hill greenhouses are of various styles. Sometimes they are built on the ridge and furrow plan with very

short slopes to the north. They are inexpensive to construct, but inconvenient to operate, because the ground in the houses usually slopes decidedly—a condition which makes work very tiresome and satisfactory watering difficult.

The even-span house (Figure 26) is used extensively. It secures an even distribution of light and gives the plants in all parts of the house the same chance, and



FIG. 26. EVEN-SPAN GREENHOUSES

for these reasons is the most popular form of construction.

Three-quarter span houses (Figure 27) have been used for many years near Boston. They usually run east and west, and plants grown in them get the full benefit of light and heat from the sun in the forenoon. The houses near Boston are usually 40 feet wide and 200 to 500 feet long.

178. Walls.—Whatever material is used in their construction, the walls should be started below frost line.

An excellent plan is to build the concrete walls $2\frac{1}{2}$ feet above grade level and bank them with earth on the outside. Walls made in this way are warm and inexpensive to construct; besides they are much better than those built of wooden posts and boards. Although cedar and locust posts last for many years, the lower boards in a wall will soon decay. If the foundation extends $2\frac{1}{2}$ feet above grade level, there will be a height of 4 feet of glass at the sides between the plate on the concrete wall and the gutter or eaves plate, where sufficient height is desired for a walk next to the wall.

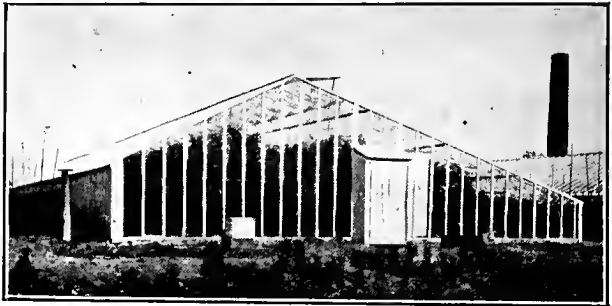

FIG. 27. THREE-QUARTER SPAN GREENHOUSE. TYPE USED NEAR BOSTON

179. **Roof construction.**—The size of the roof bars is determined by the width of the glass and the distances between posts, braces and purlins. The bars should be heavy enough to prevent sagging. Figure 28 shows an approved method of bracing. The pitch of greenhouse roofs varies from 30 to 35 degrees. When the ridge and furrow plan of construction is used, gutters must be provided between the houses. It is important, however, to avoid having gutters if possible, because they decay quickly unless made of metal. Many growers prefer to

build with a space of 10 to 15 feet between the houses. This not only renders gutters unnecessary, but avoids shading in the houses and gives room for snow.

180. Glass.—It is most economical in the end to use glass of high quality. Single strength was in common use 10 or 15 years ago, but experience has taught greenhouse men that anything inferior to A double strength



FIG. 28. A COMMON FORM OF GREENHOUSE BRACING

should not be used. The lighter and inferior grades not only sustain greater breakage from hailstones, but the imperfections may cause injury to the plants by burning.

Small glass was used extensively in the construction of the old-style houses, which necessitated placing the sash bars close together. This condition increased the cost of construction and decreased the amount of light that could enter. For many years 10 x 12-inch glass was

a very common size, but 16 x 24 is the standard size today, and is used to a much greater extent than any other size. It is generally laid with the sash bars 16 inches apart, while 24 inches between roof bars is not uncommon. Many greenhouse managers object to the bars being so far apart on account of the difficulty in making close fits between the laps. If the panes are graded before glazing so that lights of about equal curvature are placed together, there will be very little space between the laps. Twenty inches between sash bars is regarded as the proper distance by some growers, in which case 20 x 24-inch glass is used.

181. Glazing and painting.—A priming coat of paint should be applied to all wood parts before the work of construction is started. The glass is then laid in putty consisting of one part of white lead to five parts of putty. After filling the shoulders of the sash bars the glass is placed with the curve up, and pressed down firmly, squeezing out the surplus putty. This method of glazing is much better than to use putty on the glass, because the putty remains in place and keeps out water and cold air and prevents the escape of heat from the house. When large glass is used, glazing points should be inserted at the laps and midway between them. After the glass has been laid the house should receive two additional coats of paint and then be painted every year to insure maximum durability.

182. Ventilators.—Provision must be made for ample ventilation. The most approved plan is to have a line of vents on both sides of the ridge. If devices are used to prevent the ventilating sash from binding, there is no reason why they should not be continuous. If such devices are not used, at least one line of glass should separate the ventilators. They may be hinged on the ridge or on the headers of the roof bars. Both systems have earnest advocates. The ventilation is more free when the

sash are hinged on the headers, opening at the ridge; while there is, on the other hand, greater danger of cold drafts striking the plants, and rain and snow are easily admitted with this form of ventilation. But when houses are used until midsummer or later, hinging on the header is probably the better plan. Side ventilators are often provided, but many growers regard them as of doubtful utility. They are most useful in warm weather. But whatever the method of ventilation, it is of the greatest importance that the ventilating machinery work easily.

183. Beds, benches and walks.—A few years ago greenhouse growers thought it essential to provide benches with bottom heat for practically all greenhouse crops, but the opinions held today are different. In many of the largest and most successful houses there are no benches or even beds with board, brick or concrete sides. These mammoth houses often have large doors at the ends so a horse and cart can enter with manure or other supplies. It is also possible to use plow and harrow in the preparation of the soil for planting. While all greenhouse growers do not approve of horse tillage under glass, some of the most successful growers always use horse implements in preparing ground for the fall crop.

Benches are convenient in the handling of flats and potted plants, but they are expensive to construct and maintain unless made of concrete.

Solid beds, with or without sides, provide more uniform soil conditions than do shallow beds. There is less danger of injury from improper watering and, therefore, the chances of success are increased. Solid beds are especially advantageous when the watering must be intrusted to men of limited experience.

The walks should be arranged so that all the beds can be cared for conveniently. Beds or benches 5 feet wide and walks or alleys 18 inches in width make a desirable combination, although the relative width of beds in com-

mercial houses is often much greater. As plants do not do well next to the walls, it is desirable to have walks there, and the house space can then be divided in such a manner as may seem convenient for the care and harvesting of the crops to be grown.

184. Steam versus hot water heating.—Hot water is unquestionably the best system for heating small houses, and there are many arguments in its favor for large ranges of houses. If pumps or a pressure system are used to secure rapid circulation, the radiating surface need not be much greater than in a steam system. The higher cost of installation has always been one of the greatest objections to hot water. With the pressure system instead of the open tank, the water is heated to a higher temperature and also made to circulate more rapidly.

The advantages of hot water over steam may be stated as follows: (1) As the hot water in the pipes retains heat for a greater length of time, the boiler may be left for a longer time without attention. This is a great advantage in small greenhouses, where it would not pay to employ a night fireman. (2) Less fuel is consumed. (3) Proper conditions of moisture are maintained with less difficulty. Other advantages are often stated, but the foregoing are the most important. It is not so expensive, however, to install a steam plant nor so troublesome to make repairs.

185. Pipes and piping.—Formerly, 4-inch cast iron pipe was used extensively and rust joints were in common use. Wrought iron pipe is now generally employed, and it is always threaded—an advantage that makes installation more rapid and provides joints which are not so likely to leak. Most frequently $1\frac{1}{2}$ and 2-inch pipe is used for the coils in hot water heating and $1\frac{1}{4}$ -inch pipe for steam heating, connecting with mains of proper size. Whatever the system, the pipe should be placed with the greatest care, observing the principles of the method of heating to be used.

186. The boiler.—The boiler should be of ample capacity to maintain proper temperatures; forcing a boiler means a waste of fuel, and the boiler itself will not last so long. There are several types of boilers on the market. The most important point to consider in selecting a boiler is to see that the construction is of such a type that the greatest heat will be realized from the fuel consumed. The flames should strike the sections of the boiler at right angles, and the connection with the smoke pipe should not be too direct. Sectional and tubular boilers are in most common use in greenhouse heating.

187. The work room.—In every greenhouse establishment there is a great deal of work to be done in the way of seed sowing, transplanting, potting and preparing crops for market. Nothing is more important than a commodious room where all the work can be done in perfect comfort. This room should be well lighted and properly heated and ventilated. Tables of the right height are necessary, and a small room for tools will be found very convenient.

CHAPTER XIV

SEED SOWING

188. Soil selection and preparation.—Oxygen, heat and moisture are the requirements for germination, but successful results are largely dependent upon proper soil selection and preparation. Many kinds of seeds cannot germinate in stiff clay soils which are devoid of humus. Air can scarcely enter such soils. The largest seeds may germinate in extremely heavy soils, but most of the garden seeds demand a soil of the best physical condition and of fine texture. The failure to get a good stand of plants is often due to clods and coarse particles of earth, which cause the soil to dry out quickly and which prevent it from coming into direct contact with the seeds. This is a matter of prime importance. In a well-prepared soil each particle is surrounded with a film of water, and when a large number of these are in contact with the seed ample moisture is supplied for germination. A fine seed bed, therefore, is necessary for a high percentage of germination. This applies to sowings made under glass as well as in the open. Seed beds are generally improved by the application of rotten manures, and sand may also be used to advantage in heavy soils. Well-prepared soil is loose and friable and takes water readily, while a certain degree of firmness is also essential. When fertilizers are used before sowing, they should be mixed thoroughly with the soil, to prevent a considerable quantity from coming in direct contact with the seeds and causing serious injury.

189. Moisture conditions.—Proper moisture conditions previous to sowing may be secured in various ways. Fall plowing is often a great advantage in this respect, par-

ticularly in the heavier types of soil. There should be no unnecessary loss of moisture after spring or summer plowing, which can be avoided by prompt and thorough harrowing. When seed is to be sown rather late in the season the moisture can be conserved by harrowing at frequent intervals. Another excellent plan, although somewhat troublesome but practicable on a small scale, is to mulch the beds heavily with strawy manure, the coarse particles of which are removed by raking immediately before sowing. Soils which have received heavy annual dressings of manure are seldom too dry for the successful germination of seeds. Although moisture is essential, a surplus is just as disastrous as an insufficient amount.

190. Proper soil temperature.—A suitable temperature is required for each class of seeds. Lettuce, onion, beet, cabbage, cauliflower and many other kinds of seed will germinate at a temperature of 50 degrees F., or even less, although higher temperatures will cause no harm. The seeds of many vegetables, as the tomato, eggplant, bean, pepper and the cucurbits, require much higher temperatures, and they soon rot in cold, damp soils.

191. When to sow.—Experience counts for more than anything else in determining the proper dates for sowing different kinds of seed. A great many factors must be considered, but one of the most important is market conditions. When will a given crop be most likely to command the best prices, and how many weeks or months will be required to get the crop ready for that particular time? Weather conditions must be regarded. Lettuce, cauliflower, cabbage, onion, radish, spinach, and peas may be sown as soon in the spring as the ground can be prepared. This will not do for pepper, eggplant, tomato, bean, melon, squash and seeds of other tender plants, for these must not be planted in the open until the ground is thoroughly warm and there is no danger of frost.

It is always better to sow after rain rather than before, and this is especially true in the heavier soils. The soil soon bakes after a rain, and a hard surface crust is fatal to the germination of delicate seeds. Such crusts exclude air, and thus prevent the necessary physical and chemical changes in the soil, and make it difficult for the tiny plant to force its way through the soil to the light. If heavy rains fall soon after sowing, the crust can often be broken to advantage by rolling as soon as the ground is dry enough. It is usually desirable to sow in freshly stirred soil, because of better moisture conditions.

192. Quantity of seed to sow.—Many questions must be taken into account when determining the proper amount of seed to use on a given area. Among them may be mentioned: (1) The viability of the seed or its power to grow. This should be previously determined, and the rate of sowing regulated accordingly. (2) The date of sowing. It may pay to take chances in planting some crops, as beans and sweet corn, before the ground is warm enough to make certain of a high percentage of germination. By using seed freely a good stand may be secured. (3) The physical character of the soil. More seed should be used in heavy soils, because the percentage of germination will be necessarily less than in light soils. (4) The size or vigor of the young plants. Carrot and parsnip seedlings are very delicate and feeble; and many may be lost before they are well started. Therefore the safe practice is to insure a good stand by heavy seeding. (5) If to be transplanted, the time when this work will be done should be considered. The seed may be sown much more freely if transplanting is to occur in about three weeks from sowing. (6) The demand of the market. At times the market may demand small carrots, onions and other products, or exactly the reverse, and sowing must be regulated accordingly. (7) It is rather expensive to thin some crops. For example, the thinning

of onions is very slow and tedious, and therefore great care should be taken to sow just the right amount of seed. (8) Ravages of insects. Insects are usually very destructive to certain plants, as melons and cucumbers, and by using plenty of seed there will be greater certainty of saving enough plants to make a satisfactory stand. It generally pays to use seed freely and to thin when necessary.

193. Thinning.—This is an important operation in growing many garden crops, and it is often practiced in starting plants under glass, but more frequently in open-ground culture. Thinning is a process of selection; the weakest plants should be discarded, and only the most vigorous left to mature. This is one of the strongest arguments for thinning. Thinning secures a uniform stand. Because the operation is tedious and expensive successful gardeners endeavor to avoid it as much as possible by the even distribution of the proper quantity of seed.

194. Depth of sowing.—There are no infallible rules to determine the proper depth for sowing. Certain writers have advocated the regulation of soil covering by the diameter of the seed; that is, by making the covering two, three or four times the diameter of the seed. Such rules may be of some value when sowing in the greenhouse or hotbed, where moisture and soil conditions are under control, but they are likely to be misleading when applied to field conditions. The size of the seed should be considered, and also the character of the soil. In light, sandy soils the depth might be several times as great as in heavy soils. Summer and early fall sowings require greater covering than early spring sowings, because the surface layer of soil is drier, and it is necessary to place seed at a greater depth to secure the necessary amount of moisture. Some of the smallest seeds, as

celery, are often merely pressed into the soil. A very slight covering is sufficient for many seeds when the best conditions are provided. The reader should consult the chapter on the culture of the various classes of vegetables to obtain more definite information on the proper depths for planting.

195. Soaking seeds.—The soaking of seeds before sowing is of doubtful value. It may be the means of hastening germination a few days, although sowing earlier will accomplish the same purpose. When plants are killed by frost and it becomes necessary to make another sowing a slight gain will be made by soaking the seed. Most growers, however, never soak any kind of seed before sowing.

196. Broadcasting or drilling.—Some crops may be grown from seed sown broadcast, but this is impossible with plants requiring frequent cultivation. Thousands of farmers always broadcast turnip seed, while drilling is a common practice among truckers and market gardeners. Broadcasting is not without merit. It may be done very quickly, and the individual plant often has a better chance for full development than when grown by the drill method. This is particularly true with seedlings that must be transplanted. Some growers of late cabbage plants always broadcast the seed, because they claim that the plants are stronger and stockier than plants grown in drills without thinning. The same remarks apply to lettuce, whether sown under glass or in the open. Most of the arguments, however, are in favor of drilling, and the advantages over broadcasting may be enumerated as follows: (1) By sowing in drills it is possible to cultivate the soil. This is exceedingly important with practically all crops. (2) It is easier to thin when the plants are in rows than when they are scattered. When properly thinned they should be just as strong as when grown from seed sown broadcast. (3) The seed is sown

at a more uniform depth, especially when machines are used. (4) In plant boxes or small seed beds water may be applied between the rows. This is often a great advantage when damping off is likely to occur. (5) In stiff soils the percentage of germination is greater, because the seedlings assist each other in their effort to reach the light. (6) Seedlings come up straighter, and may be arranged in a more orderly manner when pulled for transplanting; therefore, they may be removed more rapidly from the seed bed, and also handled with greater speed when transplanting. Both of these advantages are well worth considering when thousands or perhaps millions of plants are to be shifted.

197. Hand sowing.—Sowing by hand in the open ground is commonly practiced by home vegetable gardeners. Lines or markers should be used at such times to secure straight rows. The furrows may be opened with a small shovel of the wheel hoe cultivator or with a rake or suitable hand hoe. One of the best ways to make a shallow furrow for small seeds is to stretch a line and follow it with the back of the garden rake which will make a neater furrow than any other tool. The seeds should be dropped at uniform distances in the furrow, and if they are small, as turnip and radish seeds, a letter envelope may be used to advantage. Seal the envelope and cut one end off; after placing several tablespoonfuls of seed in it, move it slowly over the row, shaking back and forward as may be required to secure an even distribution of the seed. After some practice seed may be sown more rapidly in this way than is possible with the thumb and fingers. The furrows may be closed by using hoe, rake or hand plow, the method used depending upon the required depth of covering.

When sowing under glass the usual plan is to make the furrows with a piece of lath or a straight-edge, or perhaps with a pot label drawn along a straight-edge,

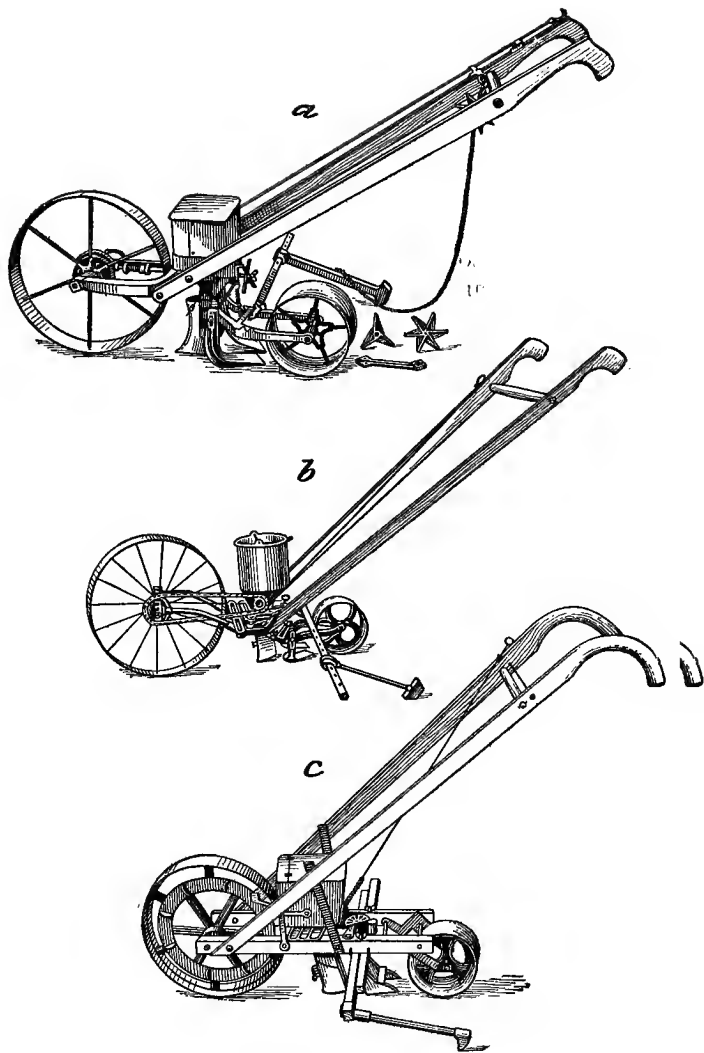

FIG. 29. DIFFERENT FORMS OF HAND SEED DRILLS

then to sow with thumb and fingers or with an envelope, as just indicated, and to cover with the fingers, or any device that may be convenient. For more complete information on this subject, see Chapter XVI.

198. Sowing with machines.—Seed sowers or drills are now indispensable in commercial gardening, because they do the work so much better and more rapidly than is possible by hand sowing. The seeds are deposited before the soil has had time to dry out; the depth of covering is uniform and the soil is compacted after sowing; the rows are also straighter and the seeds can be dropped in hills, if this is desired. There are several standard makes of seed drills, all of them satisfactory when properly used. Figure 29 shows the drills used most extensively. A wheel hoe and a drill are sometimes combined in one implement, but the tool is not very popular with commercial growers.

199. Firming the soil.—It is nearly always an advantage to firm the soil after sowing. By this operation the seed is brought into close contact with the soil particles which furnish the moisture necessary for germination. Compacting is especially important in loose soils, because it makes the capillary action stronger and insures a larger percentage of germination. Peter Henderson claimed that the most valuable chapter he ever wrote was on "The Use of Feet" in market gardening. He often had men step foot over foot on plats of several acres where the rows were only 1 foot apart. The modern seed drill does the same work, but with less force, and the roller is used sometimes for this purpose. After covering the seed, gardeners often pat the soil with the hoe blade or the back of the shovel. When sowing under glass or in small beds, sticks or blocks are generally used. Dense and compact soils need very little of the above treatment after seed sowing.

200. **Watering after sowing.**—With an overhead system of irrigation it is often an advantage to water after sowing. In the management of crops under glass, the beds are nearly always watered thoroughly after sowing. The usual plan is to try to apply enough water to render further watering unnecessary until germination is complete. The watering of flats or beds by subirrigation is regarded as an advantage by some. The beds must, of course, be water-tight. Flats are often set in shallow tanks containing about $\frac{3}{4}$ inch of water, or more if necessary.

The water soon rises in the soil by capillary attraction, and there is no danger of washing out the seed. Watering by sprinkling, however, is always satisfactory when done with care and intelligence.

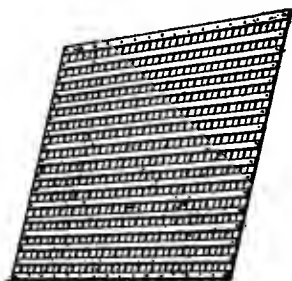

FIG. 30. LATH SCREEN

201. **Shading the seed bed.** Some soils dry out more rapidly than others, and some seeds must have a more uniform supply of moisture than

others. For these reasons shading is often an advantage. In outdoor culture, lath screens (Figure 30) are frequently used. Just half the space is covered by the lath, so that no part of the bed is shaded all the time. A screen of this kind is easy to handle and provides good ventilation. Old carpet, burlap and paper are often used in shading beds. The screen or shade should always be removed before the young plants are injured. In greenhouse and hotbed work the seed boxes are often covered with glass, which conserves the moisture and also raises the temperature when there is sunshine.

CHAPTER XV

TRANSPLANTING

202. Reasons for transplanting.—There are many important reasons for transplanting: (1) Some crops can be matured much earlier by starting the plants in hotbeds or greenhouses, transplanting in about a month and finally setting in the open ground. (2) Operations are concentrated. It is much less expensive to combat weeds, insects and diseases on a very small area than in a large field. Then, again, it is less expensive to water and to give the plants the necessary care when confined to a small plat. (3) On small areas ideal conditions can be provided for the growing of delicate plants that require nursing. (4) The ground to be used is often occupied with another crop, hence the necessity of growing plants elsewhere and of having them ready at the proper time. (5) A more ramified root system is developed. In lifting the plants, some of the small, tender roots are broken, and branching occurs to a greater extent. Severance of the roots is therefore regarded as an advantage by many practical gardeners. There are instances, of course, where it is a decided disadvantage. (6) Some writers claim that transplanting increases the earliness of certain crops, which if frequently shifted produce their salable parts sooner than if grown without transplanting. The tomato is a notable example. The theory is, that a frequent disturbance of the root system induces fruitfulness and hastens maturity.

Transplanting may or may not be a severe operation. When plants are pulled, and stripped of all soil and fine roots, it is extremely severe and often results in the death of the plants. If the shift is made with considerable soil

adhering and very few roots broken, there may be no retarding of growth. While root pruning is sometimes desirable, it should as a rule be practiced as little as possible. Plants which have a great many small, fibrous roots can usually be transplanted without difficulty. To this class belong cabbage, tomato, lettuce, eggplant, pepper, parsley, celery, onion and some others. It is difficult to successfully transplant pea, bean, corn, beet, turnip, radish, melon, squash and other vegetables, because they have relatively few fibrous roots. The transplanting of these crops is simple enough, provided their roots are not disturbed, hence the popular practice of starting some of them in pots and other receptacles and of shifting without disturbing the surrounding soil.

Transplanting is decidedly more successful in humid climates than in arid regions. It is difficult in many parts of the West to transplant to the field because of low humidity and of drying winds.

203. Soil selection and preparation.—Whether transplanting to the field or under glass, a fine soil is of prime importance. The same principle is here involved as in the germination of seeds. Unless the fine particles of moist soil come in contact with the feeding rootlets, the plant cannot become established in its new home. To secure a fine texture may require the frequent use of tillage tools in the field and the screening of soils for hotbed, cold frame or greenhouse work.

Moisture is equally important; each particle of soil ought to be surrounded with a film of water. Too much care cannot be exercised in providing the right moisture conditions. Every tillage operation should be studied from this standpoint. It may be necessary to use manures freely to increase the water-holding power of the soil or to irrigate before planting. In frame or greenhouse work where there is an abundant supply of water the problem is simple enough.

When transplanting to small beds in the open ground, as a shift before setting into the field, the most favorable spots should be chosen. Such spots should be fertile, moist, in fine tilth and free from stones, sticks and rubbish which would hinder the operation.

204. When to plant.—The time of transplanting will depend, first, upon the time of sowing and, second, upon when the space will be available for the shifted plants. These two points are usually determined months before the seed is sown. Then, a number of questions of secondary importance should be taken into account. (1) Are the plants ready for this operation? Although it may be the right date to transplant, additional time in the seed bed may be necessary to secure first-class plants. (2) Has the time passed when there is much danger of killing frosts? (3) Are the soil conditions all right—neither too wet nor too dry? (4) Are atmospheric conditions favorable? High humidity makes transplanting a more certain operation than low humidity. Cool and cloudy weather are also advantageous. If the plants have been properly grown and the soil well prepared, transplanting may proceed all day, even though atmospheric conditions are not so favorable. Just before a rain is always the best time, but when many thousands of plants are to be set, the work cannot be done in the few hours when possibly all conditions are exactly right. The latter part of the day is somewhat better than the morning, but this advantage is regarded as of slight importance by large commercial growers.

205. Markers and marking.—Straight rows and spaces of uniform width are necessary in the successful management of a market garden. They not only look better, but they also allow more rapid and thorough cultivation with less annoyance to the operator. An 80-acre market garden in Philadelphia county, Pa., is apparently faultless in this particular. In several visits to the farm not a

crooked row was apparent to the eye. The owner knows the width of the farm in inches, and even half-inch spaces are taken into account in making the rows. That is, with many crops the distance from center to center of rows is $12\frac{1}{2}$ inches rather than 12 or 13. This example is given to show how very particular the owner is as a garden mechanic. Although often 20 to 30 men are working on the farm, every row for every crop is marked by the owner. The seed drills are then guided

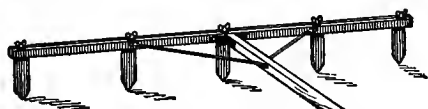

FIG. 31. POPULAR MARKER

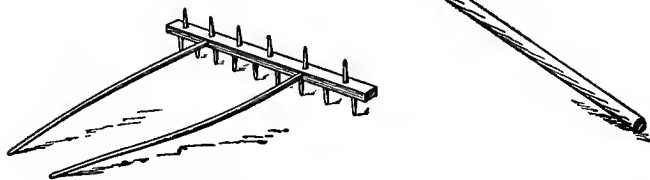

FIG. 32. HOMEMADE MARKER

over the shallow marks, or the plants are set in them. All the small crops are cultivated with hand wheel hoes and inter-cropping is practiced extensively. The second crop is often well started before the first is harvested. At such times the rows are only $6\frac{1}{4}$ inches from center to center. The reader can readily see how difficult, if not impossible, it would be to use a wheel hoe if the spaces between the rows were not uniform in width. The marker used on this farm is shown in Figure 31. It may be purchased of seed-supply houses. The teeth are easily adjusted, and the scale on the bar to which they are attached makes it possible to space the rows as may

be desired. It marks five rows at a time. If the following plan is carried out in the use of this marker, the rows will be perfectly straight.

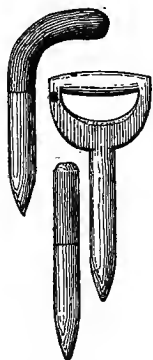

FIG. 33. DIFFERENT FORMS OF DIBBERS

If the rows are to be 1 foot apart, adjust the teeth to this distance, and stretch a line along one side of the plat to be planted. If the land slopes, the rows should always run with the hill and marking should begin at the upper side of the plat. Take the marker, and with a side tooth barely touching the tightly stretched line, walk backward marking five rows. Have a 9-foot pole at each end of the line. Measure off 9 feet from the first stakes, stretch the line and mark five more rows with the outside tooth touching the line. Repeat these operations until the entire plat is marked.

The homemade device shown in Figure 32 may be substituted, but it is a great advantage to have an adjustable marker with a scale graduated in inches and half inches.

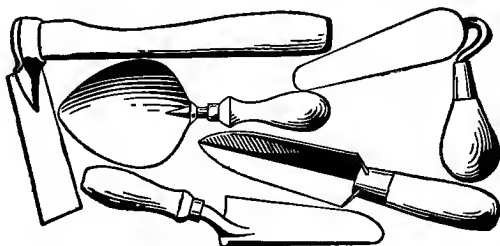

FIG. 34. DIFFERENT FORMS OF TROWELS

Roller rope markers are sometimes employed by gardeners, and there are various forms of field markers. In rough, hilly or stony ground nothing is superior to a

single shovel plow, provided it is operated by a competent man. The making of straight rows without a line, especially on uneven ground, requires considerable skill.

206. Depth to transplant.—Plants should generally be set slightly deeper than they stood in the seed bed. It is often an advantage to cover the stem up to the seed leaves. It is especially important to set spindly plants deep, especially when there is danger of freezing weather. In the South fall-set cabbage plants should always be planted up to the leaves, as this will enable them to stand the winter with much less damage than if set shallower.

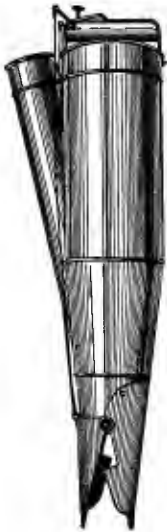

FIG. 35. USEFUL
PLANT SETTER

207. Transplanting by hand.—Various devices are used for hand transplanting. The usual tools are the dibbers and the trowels, illustrated in Figures 33 and 34. The dibbers are especially valuable for light or sandy soils, while the trowel is best for stiffer soils. When transplanting the dibber is thrust into the soil to the required depth with the right hand, and after removal the left hand places the plant in the hole. The soil is either pressed

to the roots with the hands, or the dibber is again thrust into the soil near the plant, and with a quick movement the soil is pressed against the roots. Trowels and spades may be used in a similar manner, and trowels and hoes may be used in opening holes immediately before planting. The removed ground should be pressed firmly over and around the roots. Figure 35 shows a useful setter, which has been patented; it works very well in fine soil, and applies water when desired. After some practice,

plants may be set as rapidly by this device as by any hand method. Comparatively few men are able to set as many as 8,000 plants a day, and most laborers fall below 5,000, except in close planting under the most favorable conditions.

In frame and greenhouse work small dibbers or transplanting sticks are in common use. The holes may be made and the plants fastened in the same manner as

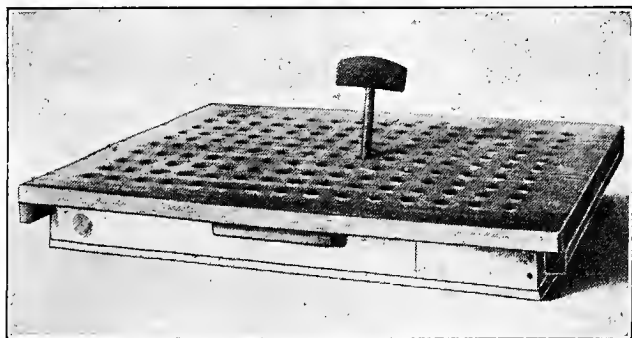

FIG. 36. TRANSPLANTING BOARD AND DIBBER

when dibbers are used in the field. It is a great advantage to have the rows straight and a uniform number of plants in each bed or plant box. To accomplish this purpose and to facilitate the work, spotting boards are often used. Sometimes these have small blocks nailed in check rows on the under side, and these merely mark places on the soil for the plants without making holes. Other boards are made with pins which may be forced into the soil, making the holes for each plant, but unless the soil is sandy and of the right degree of moisture they will not work successfully. Figure 36 shows a trans-

planting board. It may be made of two pieces, cleated with strips, and the holes bored in check rows, with a $\frac{3}{4}$ -inch bit. This board is placed over the flat of soil and the holes punched with the dibber shown in Figure 36. The point of the dibber is iron and the handle wood. The holes on the upper side of the board are beveled to receive the dibber more readily. See Chapter XVI for further notes on the use of this board.

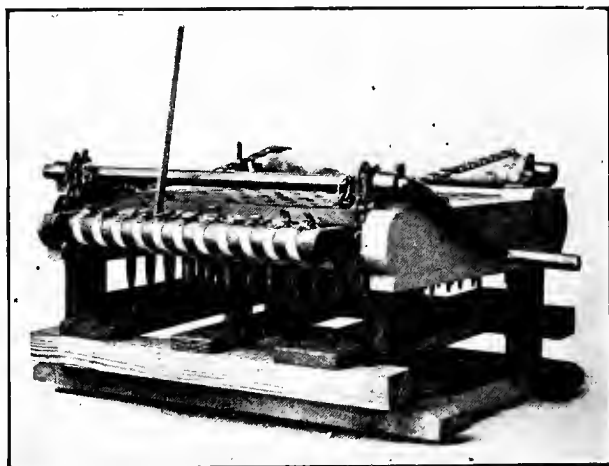

FIG. 37. DIBBLING MACHINE FOR USE WHEN
TRANSPLANTING INTO FLATS

Figure 37 shows a dibbling machine invented for making holes in flats or plant boxes. It is operated by means of two levers. One lever held by the left hand elevates the flat filled with soil, while the right hand manipulates a lever which turns a battery of spools, each provided with a metal point. With this machine a boy or a man can make 150 holes in a flat in a few moments.

Previous to transplanting into the field, it is a great advantage to allow the plants to become dry a day or so before and then water thoroughly just before the shift is made. Late tomato plants, grown in the open ground, are sometimes pulled, allowed to wilt and then sprinkled before they are planted in the field. All plants should be lifted with care, retaining as much soil as possible. Figure 38 shows a cabbage plant removed from the flat. With such a body of compost adhering to the roots there will be little check in growth. The flats are distributed over the field at convenient intervals. Boys may be employed to drop the plants. To remove them the flat is



FIG. 38. CABBAGE PLANT READY FOR TRANSPLANTING

placed on edge, lifted and jarred on the ground hard enough to make the soil or manure separate from the bottom of the flat. After taking out a plant or two in the corner, each may be removed with a liberal quantity of soil clinging to the roots. Puddling the roots, i. e., dipping them in thick, muddy water before planting is an advantage when they are stripped. It is an advantage

also to sprinkle the tops at this time, although in large commercial plantings this precaution is seldom taken. When setting in the field, the plants are usually protected from the sun to keep the roots moist and to prevent unnecessary wilting; they should be planted in fresh soil as soon as possible after pulling. Clipping the tops before planting is a benefit, especially if the tops are large or the plants spindly.

Field planting can be done very rapidly by boys when the force is properly organized. If the foreman is patient, boys can soon be taught to use dibbers or trowels. In heavy soils the following plan is satisfactory: Have a good foreman who understands boys, a man, a horse and a single light shovel plow to make furrows, which should not be opened faster than they are needed. A dozen boys make a convenient force. Let six of them drop plants and six set them. Designate the boys as droppers and planters, and give each a number, running from one to six. Have it understood that each boy is to drop or plant the row that corresponds with his number. The foreman walks behind the boys and sees that the work is done properly and that the boys are kept together. With this plan of organization, a dozen boys and two men will plant 40,000 to 50,000 plants in a day. If the boys are paid 50 to 60 cents and the men \$1.50, the cost an acre will be about \$3.

208. Watering.—As previously indicated, it is often an advantage to water ground before transplanting. This is not possible on most farms, so that good judgment and great care must be exercised to conserve the proper amount of moisture by tillage operations. When plants are set during a protracted drouth it is sometimes necessary to use water in the holes. This is a tedious and expensive operation when large areas are to be planted, and with good management it is seldom necessary. There are occasions, however, when it must be done to avoid

delay in planting. Half a pint of water poured into each hole after a little soil is drawn to the roots is sufficient. The hole is then filled with soil as moist as can be found. Watering after planting is also occasionally necessary. When this is done a small quantity of fine soil should be drawn about the plant immediately after watering to conserve the moisture.

209. Shading.—Shading is often practiced in small areas after setting plants. It is not as essential, however, as is generally supposed. Various articles are used, as paper bags, shingles, small boxes, berry boxes and boards supported by blocks of wood.

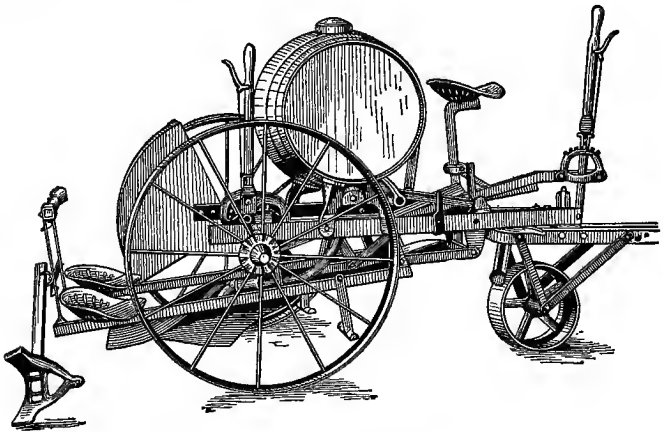

FIG. 39. FIELD TRANSPLANTER

210. Transplanting with machines.—Transplanting machines, as illustrated in Figure 39, are in general use for setting vegetables, especially cabbage and tomato plants. They do the work better and more rapidly than is commonly done by hand, and as a rule with less expense. In many sections it is impossible to secure the necessary help at the time of planting and in such locali-

ties machine planters are indispensable. They are very simple to operate, but a steady team and a careful driver are important factors. A narrow shovel opens the furrow, and the machine moves as slowly as may be necessary to enable two men or quick, careful boys, to drop the plants alternately in the narrow furrow. Shoes or rollers close the furrow, pressing the soil very firmly to the roots and stems. Water may be used with each plant if desirable. By quick work the plants may be set 15 inches apart or even closer.

CHAPTER XVI

GROWING EARLY VEGETABLE PLANTS UNDER GLASS

211. Soil supply.—Soils for growing early vegetable plants should absorb water readily and dry quickly on the surface. A sandy loam furnishes ideal conditions. Heavier soils can be improved by the addition of sand and rotten manure. Suitable soil for this work can often be found in garden or field, or it may be prepared by composting. The most convenient method of preparing soil for this purpose is to select a suitable area and apply manure freely. Spread the manure to the depth of 4 or 5 inches, plow the land and harrow once or twice. This work should be attended to in the spring as soon as the ground is dry enough for plowing. After the manure is partially decayed, plow and harrow again, and repeat these operations occasionally during the summer. The soil should be in excellent condition for storage in the fall.

Manure and sod, stacked in alternate layers of 4 to 6 inches deep, also make a soil of superior character for starting early plants. When soil is prepared in this manner, about a year is required for the thorough decay of the materials composted. Shoveling the pile over a few times during the latter part of the period of composting helps to secure a fine and well-mixed soil. Whatever soil is selected or prepared great care should be exercised to avoid germs of troublesome diseases. For example, soil for raising cabbage plants should never be taken from a field where any plants of the cabbage family have been recently grown. When dry enough to handle without injuring the texture, it should be stored

under cover where it will not be in a frozen condition when wanted for use.

212. **Flats and plant boxes.**—Flats are often used in greenhouses, and they are practically indispensable when starting plants in hotbeds and cold frames. Notwithstanding this, many gardeners do not use them extensively, for they have not learned their advantages, which may be enumerated as follows: (1) They make it possible to do all the work of seed sowing and transplanting in warm, comfortable rooms provided with tables or benches of convenient height. Because of these comforts and conveniences, more work can be accomplished in a day, especially if the weather is cold or disagreeable, and it will be done better than when the worker must stoop over frames. (2) Sowing or transplanting may be continued whatever the character of the weather. When transplanting in severe weather, the box of plants should be protected by a cloth or a box when carried to the work room. So should the flat of transplanted seedlings when taken to the cold frame. (3) Many growers claim that they can grow better plants in flats, because moisture conditions are more perfectly controlled. (4) Each flat contains a uniform number of plants, and this is a great advantage when making sales. (5) In shipping, the flats of plants may be crated, if this is desired, and they will reach their destination in perfect condition. (6) When planting in the field the flats may be hauled and distributed over the field at convenient intervals. (7) The plants may be pulled with a large amount of soil, as shown in Figure 38. Some gardeners go to the trouble of cutting out each plant with a block of soil or of compost.

Flats may be made from soap boxes or other boxes of convenient size. This is doubtless the most economical plan, but there are objections to it. The lumber in a miscellaneous lot of boxes is variable in quality and dura-

bility, and the flats are not uniform in size. Because of varying dimensions they cannot be placed in the frames without loss of space. When this annual loss is taken into account, it makes a strong argument for a uniform size of flats. When new lumber is used, the flats should be made to fit in the frames or on the greenhouse bench without loss of space. Chestnut is a durable wood for this purpose. The sides and bottoms should be made of $\frac{1}{2}$ -inch and the ends of $\frac{3}{4}$ -inch pieces. When nailing on

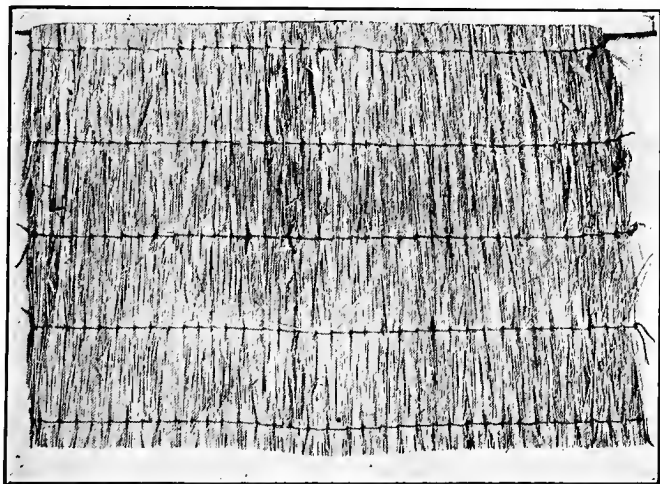

FIG. 40. RYE-STRAW MAT

the bottom pieces, about $\frac{1}{4}$ -inch cracks should be left between them, to provide good drainage. Two inches is ample depth for most purposes. A deeper flat requires more soil and makes handling heavier. If the flats are about $2\frac{1}{2}$ x 16 x $22\frac{1}{2}$ inches, outside dimensions, three of them will fit in a 6-foot frame without an appreciable loss of space. Flats of smaller size are convenient for the retail plant business.

213. Mats and shutters.—Various kinds of mats are used to protect plants in hotbeds and cold frames. In some sections lath crates about 3 inches thick, stuffed with fine hay or sea weeds, are used for this purpose. They furnish excellent protection, but are heavy and inconvenient to handle. Burlap mats stuffed with cotton waste are on the market, but they are difficult to keep on the frames in windy weather; they furnish poor protection when wet and are lacking in durability. Canvas mats are satisfactory, but are too expensive for general use. When all points are considered, rye-straw mats are most serviceable; they are inexpensive, are not easily displaced by even hard winds and furnish thorough protection. Machine-sewed mats of this type, as illustrated by Figure 40, are on the market, or they can be made by hand. The mats made by machine are uniform in thickness and are much neater than can possibly be made at home, unless an unusual amount of time is spent on each mat. When not in use, mats should be stored under cover where rats and mice will not damage them. With good care they will last several years. A mat is generally large enough to cover two sash, 6 x 6½ feet being the popular size.

Shutters are sometimes used instead of mats in covering frames. They may be made of light lumber and may be of any convenient size. When used alone on frames they do not protect the plants nearly as well as mats. Sometimes shutters are used over the mats, which they protect from rain and snow.

214. Sowing.—Chapter XXI gives information on the proper dates for sowing.

When flats are used in sowing cabbage, lettuce, tomato, pepper, parsley and other seeds, the operation should be carried out in the following manner: Fill the flat with soil moist enough to work well. Sprinkling while the soil is being turned may be necessary to secure the proper

amount of moisture. See that the soil is pressed firmly in the corners and along the sides. With a straight-edge, make furrows $1\frac{1}{2}$ to 2 inches apart and $\frac{1}{4}$ -inch deep, the first row being about $\frac{1}{2}$ inch from the end of the flat. The rows should be parallel and neatly made. With an envelope, distribute seed at the rate of about 12 to the inch. Close furrows in the most convenient way; firm the soil with a block; water and place in the proper temperature. Fifty to 60 degrees Fahrenheit provides the best conditions for lettuce, cabbage and cauliflower, while



FIG. 41. FLAT OF CABBAGE SEEDLINGS

70 to 80 degrees is better for tomato and other tender vegetables. Figure 41 shows a flat of cabbage seedlings. A flat of this size should produce about 1,000 plants.

215. Care of seedlings.—Proper temperatures must be provided for the growing seedlings. If too high, the plants will be spindly, soft and tender. Some fresh air should be admitted to the hotbed or the greenhouse every day. Water must not be used too freely, for excessive watering and high temperatures are certain to produce weak plants. Apply water in the morning, if possible, and try to have the foliage dry at night to avoid damping-off fungi.

216. Transplanting.—Some growers begin transplanting a few days after germination, but it is generally

better to start the work in three or four weeks from sowing, or when the true leaves are forming. If many plants are to be pricked out, the work should be started promptly and completed as soon as possible, in order to prevent the plants from becoming spindly.

If flats are to be used, the work may proceed as follows: Place about $\frac{3}{4}$ inch of partly rotted manure in the bottom of the flat and fill with soil. See that the soil is firm over the entire box and especially in the corners and along the sides. With a leveling strip remove the surplus soil and leave the surface smooth. The holes may be made with a machine (Figure 37), or by the use of the transplanting board (Figure 36). When the board is used it should rest firmly on the soil over the entire surface; hold the board in place with one hand, and with the other punch the holes with the dibber shown in Figure 36. A boy will soon learn to do this work very rapidly. If the soil is in proper condition and the board and the dibber are used skillfully, every hole will remain open when the board is removed.

The seedlings should be watered at least 24 hours before being transplanted, so the tops will be dry and the work of transplanting be greatly facilitated. The soil will be moist enough for the plants to be removed without serious mutilation of the roots. The plants should be handled carefully and kept in orderly arrangement in order to save time in dropping. The flat which has been previously dibbled is placed lengthwise on the bench or the table. A bunch of plants is held in an orderly position in the left hand near the holes while the other hand drops a good plant into each hole, beginning at the left end of the far row, and leaning it against the side of the hole toward the side of the flat farthest from the worker. The plants are dropped in the same manner in each row of holes, all the plants leaning in the same direction. The observance of these details is of importance for speedy

work. Boys and girls soon learn to drop the plants very rapidly, but it is better to have experienced workmen set the plants. This operation may be done very rapidly with thumbs and fingers or with the index finger of one hand and a small dibber in the other. Many gardeners make the hole with a small dibber, drop the plant and secure it at once. This is unquestionably the best plan when plants are 3 or more inches high, but the board method just described is much better for small plants when a large force of unskilled laborers is at work; it insures straight rows and a uniform number of plants in every flat.

217. Care after transplanting.—If the soil was made sufficiently moist before planting, little or no water is needed immediately after. The boxes may be taken to the hotbed or the greenhouse or placed in the cold frame, as may be required.

After transplanting, the flats should be looked over every day and late in the spring twice a day and watered whenever necessary. Until established, ventilation should not be too free. Seedlings planted in cold frames during the early spring often need no ventilation for a week or more. After the plants are well started more air should be admitted and the amount of ventilation increased as the season advances and as the plants become larger and stronger. Cold drafts upon small tender plants should be avoided as much as possible. This may be accomplished by opening the sash on the side of the frame opposite the prevailing wind.

218. The use of mats.—Mats are essential in the frame culture of early vegetable plants in the North, although double glass sash are used without mats in the milder sections. Mats should be placed on the sash about 4 o'clock in the afternoon in cold weather, and later in the day as the spring advances; but they should not be removed in the morning until the temperature outside is

rising, and in very cold weather it may be best not to remove the mats at all from cold frames for a few days or even as long as a week in extreme cases. In March there may be heavy falls of snow with zero weather for many days, with little or no sunshine. Under such conditions it is better not to remove mats. While the plants do not grow when thus excluded from the light, they will not be injured by close confinement at low temperatures.

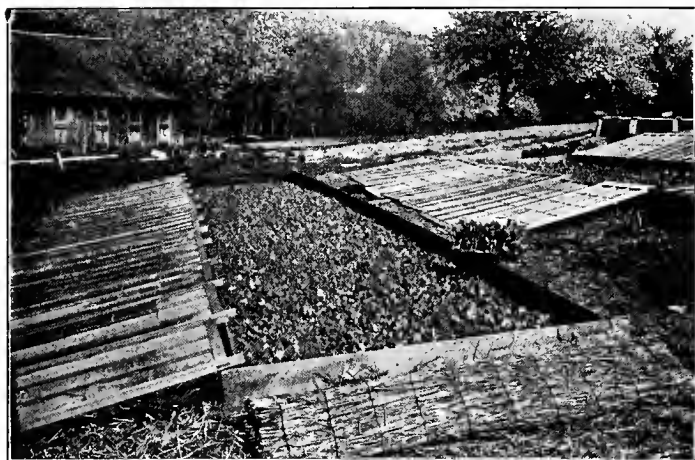

FIG. 42. FRAME OF HARDENED CABBAGE PLANTS

The durability of straw mats depends largely upon care. When deep snow covers the mats, it should be shoveled off before an attempt is made to remove them. When they are wet or covered with an inch or two of snow, the best way to remove them is to walk along the lower side of the frame, grasp the mats at the cords and double them over as far as possible toward the other side. Then go to the upper side of the frame and draw

off the mats by taking hold of the lapped-over ends. If wet, they should be spread flat on the ground or, better still, supported on a fence to facilitate drying. To cover the frames in the evening when the mats are wet, proceed as follows: Walk on the mat, reach backward, grasp the far end with both hands, walk over the frame at a cross-bar and drop the mat in place. When dry, they are handled rapidly and with ease.

Mats are also useful in shading plants. The glass may be covered entirely in hot weather, or the opposite edges of the mat may be turned back, exposing 6 to 12 inches of glass along each side of the frame. This method of shading is especially valuable when transplanting is done late in the spring.

219. Hardening plants.—This process is the firming of the tissues in order that the plants will be able to endure the hardships of transplanting and of open-ground conditions such as freezing, hard drying winds or hot sunshine, any of which may damage or destroy soft, tender plants. Figure 42 shows a frame of well-hardened cabbage plants which when photographed were of reddish-blue color, short and stocky. Such plants will stand a temperature of 12 or 15 degrees above zero.

Plants are hardened by watering sparingly, subjecting them to low temperatures and by providing free ventilation. These operations are equally valuable. When hardening is begun, no more water should be used than is necessary to prevent serious wilting. Air is admitted more freely from day to day. At the end of three or four days the sash may be removed entirely during the day, and the frames closed late in the evening and opened earlier than usual the next morning. Matting is not practiced after a few days more of such treatment and, finally, no protection of any kind is given day or night. This general plan of hardening is primarily for the more hardy plants, as cabbage and lettuce. Tomatoes, peppers and

eggplants must be handled more cautiously, although hardening is just as necessary for them. Millions of plants are lost annually because they have not been properly hardened.

220. Pots, sods and other devices.—As previously stated (202), some plants, as melons, cucumbers, beans and sweet corn, are difficult to transplant because they contain so few fibrous rootlets. It is often an advantage, however, to start them under glass, but their root systems must not be disturbed to any great extent. This may be accomplished by the use of earthen or paper pots, sods, berry baskets, paper oyster buckets and dirt bands. Earthen pots are highly satisfactory, but are expensive when used in large numbers. Paper pots are becoming

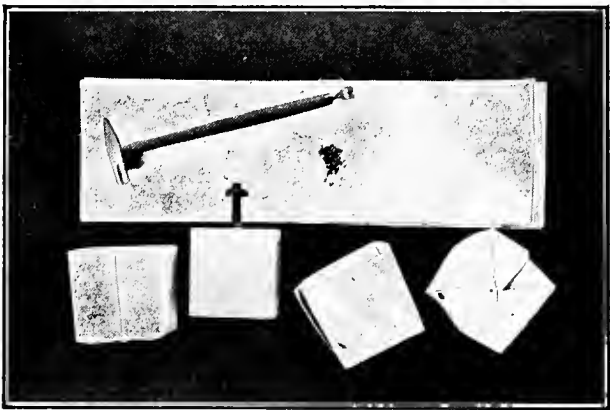

FIG. 43. PAPER POTS AND EQUIPMENT FOR MAKING THEM

popular, and may be made with little expense. Figure 43 shows some pots and the necessary equipment for making them. The operation is very simple. A rectangular strip of paper of the proper size to make the pots desired is folded around a square block bolted

through the center to a table. The paper is folded in and clinched in the center with a single upholstering tack driven over the end of the bolt. When planting in the field the paper should always be removed to prevent interference with root development. Melons and cucumbers are often planted on sods. Berry baskets and veneered 4-inch dirt bands, folded into squares, are very useful for starting the above plants.

CHAPTER XVII

MARKETING

221. Modern methods.—The commercial grower desires, of course, to make maximum profits. He has for years been acting upon the assumption that if he produces a large crop of the best quality and places it upon the market in the usual style, whatever that may be, he has done all in his power; and if the gross receipts fail to cover the cost of production and marketing he is not responsible for the loss. We have learned, however, that the problem of marketing bears a closer relation to profits than the art of production, and that it is often more intricate. Experience has taught the gardener that modern methods of marketing must be used to realize the largest net returns. The problem is far reaching, for it begins at harvest and ends when the consumer has taken the last bite and has ordered the same dish for the next meal.

Some gardeners are experts as producers and failures as marketmen. This is to be expected because the problems are different. There is no reason, however, why successful producers should not meet with at least fair success in the disposition of their crops; but they must study and master the details of marketing just as zealously as they have studied and mastered every point that counts for successful production.

222. The principles involved.—The ultimate aim of both grower and salesman should be to satisfy the consumer. This is the fundamental principle involved in the successful disposition of all kinds of produce, and obedience to it secures quick sales, good prices and increased demands. Too frequently the gardener does not look

beyond the middleman. He may be jubilant over sales to the retailer or the wholesaler, but let us follow the vegetables to the consumer's table. The vegetables look fairly well perhaps when delivered and when served on the table, but nobody asks for a second helping and there is no request for the same vegetable the next meal or the next day. Thousands of experiences of this kind in a great city reduce subsequent purchases. In other words, poor quality necessarily results in low prices and slow sales. Now, suppose the vegetables are extra fine in quality. Every member of the family is pleased; each becomes enthusiastic and tells the neighbors; the demand increases, prices are maintained or raised and the problem of disposition has been solved.

The following considerations must be taken into account in the attempt to win the consumer: (1) High quality is essential. (2) Attractive appearance is exceedingly important. If an article appeals to the eye the sale is more than half made. This idea involves the grading of produce with reference to size, color, shape, ripeness and soundness; packages which are attractive; package ornaments, as laced paper and fancy covers; tying materials and branding. (3) Honesty in packing is essential. (4) The vegetable must be seasonable; i. e., ready for market when the consumer is most anxious for it. (5) The package must be convenient in size and shape; a neat handle is often a great advantage. (6) If vegetables are of high quality the package should contain the grower's name and address.

223. Harvesting.—Some classes of vegetables, as sweet potatoes, are harvested at one time; that is, the entire crop on a given area is removed the same day, perhaps, and the ground is then available for something else. Other crops, as tomatoes, are not all ripe at one time and several or many pickings are required. Again, some vegetables, as melons, must be harvested and marketed

as soon as they are ripe or mature; while others, as beets, may be left in the field for days or even weeks until market conditions become favorable, or until it is convenient to gather the crop.

When harvesting garden crops, consideration should be given as far as possible to soil and weather conditions. Heavy soils are seriously injured if tramped or disturbed when wet. This difficulty, however, is often unavoidable. It may be much better, and certainly it is more comfortable, to harvest crops in pleasant weather. Thousands of gardeners, however, go to market every day during the summer and the produce must be gathered regularly without regard to the character of the weather.

Promptness is of the greatest importance in harvesting the most perishable crops. A day's delay may result in heavy losses, especially in hot, sultry weather and in seasons when destructive frosts or freezes are likely to occur.

The organization of the field force of men demands careful study. It is imperative to have an alert, tactful foreman who is thoroughly familiar with every detail of harvesting and well qualified to direct men. It is usually possible to assign each laborer to one or two rows, and thus simplify the work of the foreman and place definite responsibility upon each person. If baskets are used, an ample supply should be kept close at hand, and when the force is large it may pay to have a boy look after this matter. He should see that an empty basket is within the reach of each picker the moment it is needed. Special roadways are necessary in collecting crops all of which are not harvested at one time. In some cases planting distances can be adjusted to make it possible for the wheels of the wagons to straddle a certain number of rows. With other crops the earliest maturing varieties may be planted on the strips wanted for roads. This ground will be almost if not entirely free when the later varieties are ready to harvest.

A great many different methods are used in collecting the crop. A bulky crop, such as cabbage, is often placed on the wagons immediately after cutting and hauled to market without further attention, while many crops, including cabbage, are frequently packed in the field in barrels or crates and then hauled to market or to the shipping station. Various types of two-wheel carts are in common use in collecting crops. Hundreds of them are employed by Norfolk truckers. In the Boston dis-



FIG. 44. CART USED NEAR BOSTON FOR COLLECTING VEGETABLES

trict the cart shown in Figure 44 is a popular type. At least 30 bushel boxes may be stacked on the large platform, and the broad tires will prevent the wheels from sinking very far into soft ground. Low platform wagons with broad tires are especially desirable. Wheelbarrows provided with large boxes are frequently used in small plantations. The picking basket should be well made and provided with strong drop handles, so that the baskets

will nest snugly. Every possible effort should be made to prevent bruising the vegetables.

224. Facilities for packing.—Vegetables are sometimes packed in the field where grown, when they do not need to be washed or handled very much before packing. There are serious objections, however, to field packing which as a rule does not admit of thorough grading. There is also greater danger of the vegetables going to market without being properly cleaned. It is also difficult to load for market in the field, especially if the ground is soft or the land hilly. The field lacks the proper facilities for packing. For this reason all market gardeners and many truckers have packing sheds or houses.

The building used for packing may be temporary or permanent. It is often convenient to have a cheaply constructed shed in or near the field, although there are many arguments in favor of a permanent house which may constitute the center of activities and be the headquarters during the market season. Various crops may be brought from different fields to the packing house, so that the foreman may have opportunity to inspect every package before it is loaded for market. Every facility and convenience should be provided for the speedy handling of each crop.

The packing house should be centrally located, near the other farm buildings if possible, and should be substantial, convenient, comfortable, well lighted and properly ventilated. Comparatively few packing houses meet these conditions; they are usually dark, dingy rooms lacking many facilities and conveniences of arrangement.

The main floor of the packing house should be made of concrete, sloping gently to drains. Water may then be used freely in washing vegetables or wagons. If the house is to be used in cold weather, the doors should fit snugly and provision be made for heating.

The house should be of ample capacity, with space provided for shifting the wagons if necessary. Crowded conditions when unloading, grading, packing and loading necessarily result in a loss of time. Room must also be provided for the storage of packages.

One of the most satisfactory houses in New Jersey is arranged in the following manner: Large receiving doors which open on the packing floor are located at one end of the house 4 feet above the roadway. The packing floor is $5\frac{1}{2}$ feet above the level of the loading drive, which runs through the center of the house. Packages are stored in the other end of the house and also in the loft over the packing floor.

The packing floor must be provided with tables of convenient height. These are used when grading, bunching, tying and packing. Facilities for washing should be given special attention. Ordinary washtubs are often used, but they are not fully satisfactory. A large round or rectangular tank made of wood and perhaps metal lined, is used by many market gardeners. An abundance of clean water is necessary for thorough washing and the hose can often be used to advantage. The packing house of a modern establishment is not complete without a small office room, or at least a desk, and telephone connections with the markets if vegetables are to be sold locally.

225. Preparation for market.—After the vegetables are received at the packing house several operations are necessary before they can be ready for packing. Many different classes of vegetables, as beets, carrots and other root crops, are washed to remove any soil that adheres. Water is used mainly for the sake of cleanliness, but it has other values which deserve consideration. It gives many vegetables a fresh, bright appearance and prevents them from becoming wilted and withered before reaching the market. Plumpness is also maintained, as is the case when the green pods of peas and beans are immersed

in water for a few moments before packing for local markets. Thorough washing is generally regarded as necessary for celery, lettuce, asparagus and all of the root crops, and considered an advantage under certain conditions for many other crops. Whatever the vegetable, it must be clean to make a favorable impression on the buyer, although it is not always advisable to use water freely. Tomatoes, cucumbers, watermelons, muskmelons, squashes, peppers and eggplants can usually be wiped with a damp cloth to secure the required cleanliness.

Vegetables which are bunched may be washed before tying, but the most common practice is to wash after tying, because the work can then be done more rapidly. The bunches are thrown into a tank of water and washed; a brush is used if necessary. When the vegetables are not too much soiled, the use of the hose may be sufficient. Bunches of vegetables, like asparagus, celery and rhubarb, are often placed on end in washing tanks and water applied with considerable force from the hose, but scrubbing is also necessary sometimes.

Certain vegetables require trimming, stemming or shelling before packing.

226. Packages.—Many factors must be considered when selecting packages: (1) The most advantageous size must be determined. This is an age of small packages, which are gaining in popularity among both vegetable growers and vegetable buyers. As a rule, produce sustains less injury in transportation when in small packages, and the vegetables are always more attractive and more convenient to handle. This last fact is especially important from the consumers' standpoint. Any child can carry home with ease and delight the packed 2 or 4-quart basket represented in Figure 45, b. Although bushel baskets, (Figure 46, b and c) are used in some sections, they are too large for most purposes.

(2) The appearance of the package counts for much in making satisfactory sales. Is it neat, rather than clumsy? Is it bright in color instead of dull and dingy? Does it add to the attractiveness of the vegetables, making the display more pleasing?

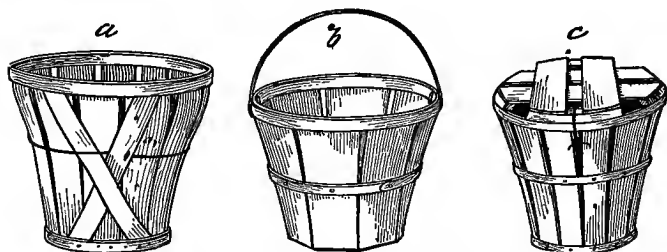

FIG. 45. POPULAR PACKAGES

a, Well-braced $\frac{3}{4}$ -bushel basket; b, 2 or 4-quart basket, one of the best retail packages; c, half-bushel basket with cover.

(3) Is the package a satisfactory carrier? Do the vegetables reach the market in first-class condition? The package must be adapted to different seasons of the year; i. e., in summer it must provide proper ventilation, in winter thorough insulation against cold, but at all times it must furnish the best possible protection against

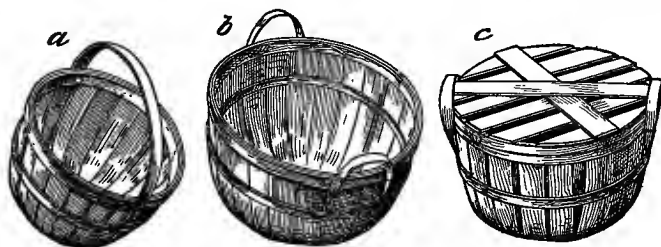

FIG. 46. POPULAR PACKAGES

a, Half-bushel picking basket; b, bushel picking basket, also used in some sections for marketing; c, bushel basket with cover for shipping.

thieves encountered in transportation. It should also be of such a character that the vegetables will reach the market in the best possible condition so far as freshness and soundness are concerned.

(4) The package must also be adapted to the size, shape and solidity of each particular crop. (5) It should be convenient to handle. This is one of the reasons why the 2 and 4-quart baskets (Figure 45, b) are so popular with the retail trade. The neat copper bail invites purchasers. These baskets are winners, because they are small, neat, attractive and convenient.

(6) The cost is an element to be considered, but the least expensive packages may be the dearest in the end. A safe policy is to buy the best as cheaply as possible.

(7) Is the product to be shipped or sold locally? Some dainty packages are excellent for a home trade, but they are not satisfactory for shipping.

(8) The demands of the market must, to a certain extent, be recognized; that is, if a market has become accustomed to a particular style of package, there are certain advantages in the exclusive use of this particular package. A superior package, however, always attracts attention.

(9) The nesting, loading and carrying qualities of a package are important considerations. It is a great convenience to be able to nest a large number of baskets. When loading on the wagon, economy of space is important, and it gives the driver an easy and comfortable feeling to know that the packages are riding satisfactorily and that there is no danger of their upsetting or falling off.

There are so many different types of packages that amateurs are usually perplexed as to what to buy. Barrels are used in immense numbers, especially in handling heavy crops like potatoes, sweet potatoes, root crops and squashes, and are also used extensively by southern

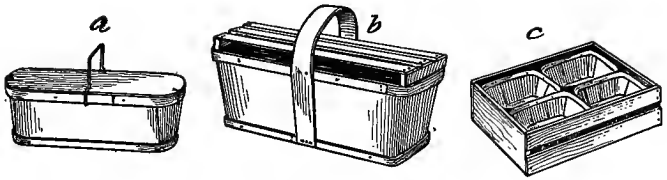

FIG. 47

a, Three, six, eight and ten-quart basket; b, 5-pound basket, desirable for many classes of vegetables; c, California crate, four five-pound baskets.

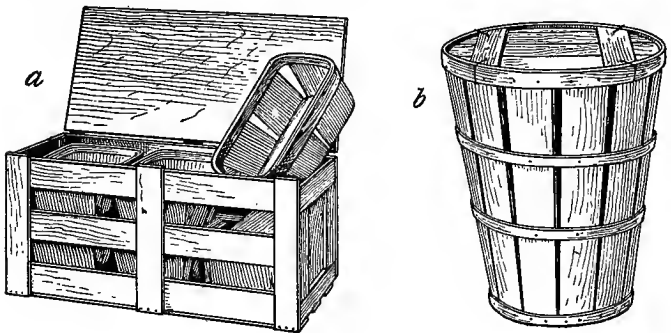

FIG. 48

a, Florida tomato crate or carrier, also used for other vegetables; b, hamper made in sizes up to a barrel capacity.

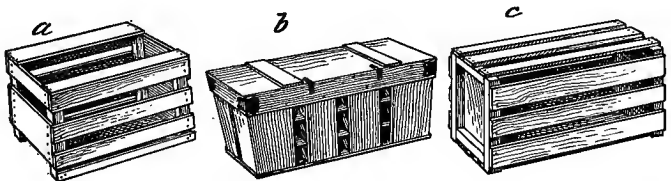

FIG. 49

a, Bushel tomato crate; b, six-basket nesting crate; c, sweet corn and cantaloupe crate, 12 x 12 x 24 inches.

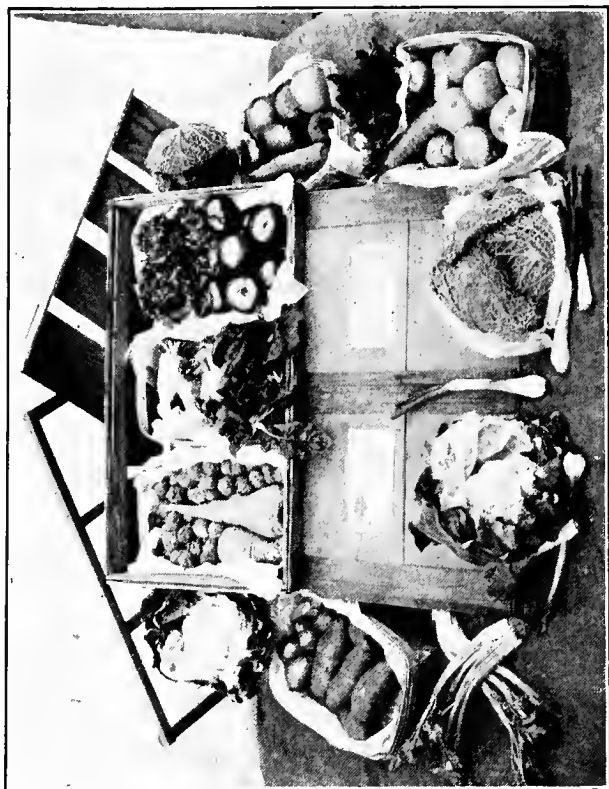

FIG. 50. LONG ISLAND HOME HAMPER

gardeners in shipping kale, spinach and lettuce. Almost anything may be packed in barrels. The barrel is the standard package employed by Long Island gardeners, and is used largely by most gardeners in Philadelphia County, Pa., and, in fact, more or less throughout the country, for many classes of vegetables. The barrel is clumsy and inconvenient to handle and far from being attractive; yet it will continue to be a popular package for many of the heavier vegetables.

Bushel boxes are held in high esteem in some sections, especially around Boston. They are 16 inches square and 8 inches deep. While many producers and dealers do not favor this package, it has decided advantages, which are as follows:

(1) It is easy to pack. (2) It loads compactly and hauls well. (3) It is strong and durable.

There are many types of baskets. The $\frac{5}{8}$ and $\frac{1}{2}$ -bushel baskets (Figure 45, b and c) are widely used both for shipping and selling locally. The hamper (Figure 48, b) is also used extensively in shipping cucumbers, spinach, kale, lettuce, radishes, peas, beans and some other crops. Carriers of various designs are coming into more general use every year. One of the best is shown in Figure 48, a, containing six 4-quart baskets. The Long Island home hamper (Figure 50) has proved to be very successful in supplying a high-class city trade, being shipped directly to the consumer. This crate is 10 inches deep, top length 24 inches, bottom length $21\frac{1}{2}$ inches, top width $13\frac{1}{2}$ inches, bottom width $10\frac{1}{2}$ inches. Crates of various sizes and designs are in common use.

It often pays to buy packages in the "knock down." The freight rates are less when they are shipped in compact form and less storage room is required in the packing house. If possible, carlot shipments should be secured, several neighbors clubbing together when necessary to make up a car.

Very little effort has been made to standardize the size of different kinds of packages. It would be necessary, of course, to have different sizes of some styles, but the whole matter could be easily adjusted. The dimensions or capacities of truck barrel hampers, half-barrel hampers, six-basket carriers or crates and other classes of packages should be uniform throughout the country.

227. Grading.—Careful grading is imperative for discriminating markets. Uniformity in size, shape, color, markings and ripeness counts for more than most growers realize. Eighty bushels of tomatoes properly graded will bring more money on most markets than 100 bushels ungraded. One inferior specimen may repel a dozen buyers.

The number of grades necessarily varies with the market and the vegetable to be graded. It is generally profitable to make at least three market grades, according to size or other points of merit. The work of grading should be most carefully supervised in order that the grades established be maintained. Badly damaged and very imperfect specimens should be discarded.

228. Packing.—There are three main considerations in the packing of vegetables after they have been cleaned and graded and a desirable package selected.

(1) The appearance of the product must be attractive when offered to the public. Attractiveness is secured not only by cleaning, grading and using the proper package, but the vegetables must be tastefully arranged. It often pays to place each specimen in the most careful manner. The value of skillful arrangement has been clearly demonstrated by the California fruit growers. Not only should the top layer show to an advantage, but the arrangement should be pleasing down to the bottom. A pleasing appearance may also be secured by lining the package with white paper; by using a border or cover of laced or fancy colored paper; by covering with red mos-

quito netting; by wrapping each specimen with soft paper; by tying bunched vegetables, as celery, asparagus, rhubarb and the root crops, with blue or red tape; and by branding or labeling wrappers, covers or packages. (229.)

(2) Honest packing is absolutely essential. This means uniformity of grade throughout the package, and it prohibits "topping." The crates or baskets should be as large as they are represented and packed full.

(3) The specimens should be placed in such a manner that they will remain firm and in position until the market is reached, to avoid bruising.



FIG. 51. BUNCHING ONIONS IN THE FIELD

As previously indicated (224) the work of packing or bunching is sometimes done in the field. (Figure 51.) Packing requires close supervision. When a force of laborers is at work it is desirable to give each one a number and require everyone to place a slip of paper in

each crate or basket giving the number of the packer. This system secures better work and makes it possible to locate careless packers when complaints are made. Packing may be done by the piece if desired.

229. Advertising.—All classes of producers find that it pays to advertise. If you have something to sell that is really good, let people know about it. If you are selling vegetables that you know will please dealer or consumer, the package should contain information telling where more vegetables of the same kind can be procured.

There are many different methods of advertising. Branding the product or the package is effective. The brand may consist of a small round or rectangular label pasted on each specimen. A New Jersey melon grower uses the following legends, printed with red ink on white paper: "Guaranteed, grown by _____, Moorestown, N. J.," and "Jenny Lind cantaloupes, grown by _____, Moorestown, N. J." The paper, which is about 2 inches wide and 3 inches long, requires only a moment to paste. Printed paper wrappers of various sizes and colors may be bought of special dealers. They are particularly desirable for tomatoes, eggplants, peppers and cauliflower. A common practice is to place rather large and substantial labels on the packages. Printed cards are sometimes placed immediately under the cover and occasionally in the interior of the pack. A tomato grower claims that the following statement, placed about in the middle of each half-bushel basket enables him to average 10 cents more a basket a season: "Grown by _____, Hammon- ton, N. J." The crop is sold on commission in Philadelphia. If the consumer asks his grocer for another basket of Mr. _____'s tomatoes, the grocer is, of course, practically compelled to buy the same kind from the wholesale dealer. Advertising of this character is always effective.

Circulars and postal cards tastefully worded and illustrated can sometimes be used to advantage. Newspaper advertisements are valued by some gardeners who sell at retail. A Minnesota grower who supplies consumers carries a newspaper advertisement for six months of the year, changing it in every issue. The market wagon should be neatly lettered. Gate bulletins are useful when vegetables are for sale at the farm.

230. Market wagons.—The size of the market wagon will be determined by the number of horses to be used,



FIG. 52. PHILADELPHIA MARKET WAGON

character of the road, method of selling and volume of produce to be handled. The carrying capacity of a one-horse wagon should seldom be less than 1,500 pounds, and on hard, level, smooth roads, it should be from 2,000 to 3,000 pounds, especially if the vegetables are to be shipped or sold at wholesale. Wagons for two and three horses are made to carry from $1\frac{1}{2}$ to about 8 tons, a three-ton wagon perhaps being the most popular size. A large and satisfactory wagon recently built by a Bos-

ton market gardener weighs 4,900 pounds; the axles are $2\frac{3}{4}$ inches in diameter; the springs are 3 inches wide, front springs 18-ply and rear springs 19-ply; it is drawn by three horses hitched abreast. On it 275 bushel boxes (16x16x8 inches) of onions have been hauled to market, and at another time 350 bushel boxes of bunched beets were transported.

Market wagons differ widely in style. The Boston platform type is highly satisfactory for hauling bushel



FIG. 53. PHILADELPHIA MARKET WAGON PARTLY LOADED WITH BOXES

boxes. A narrow strip along the upper edge of the bed on each side slightly tilts the outside tier of boxes toward the center of the bed, but the loads are always roped.

A wagon used in New Jersey is made to carry 180 half or $\frac{5}{8}$ -bushel baskets. This is a typical New Jersey wagon used in hauling produce to the Philadelphia market. Figure 52 shows the type of wagon used in

Philadelphia County, built to carry about 4 tons. Figure 53 shows the same type of wagon loaded with boxes. A canvas top over the driver furnishes protection in stormy weather. Figure 54 represents the type of wagon used on Long Island for hauling barrels. On the largest wagons of this type 110 barrels are sometimes loaded. A canvas covering is always thrown over the load for protection and to hold the barrels in place.



FIG. 54. LONG ISLAND MARKET WAGON

Figure 55 shows a wagon which is especially convenient for retailing.

Market wagons should be planned with the utmost care, size and style being the first essentials to consider. As a general rule market wagons are too small. The type of construction must conform to the style of packages to be hauled. The Boston wagon described is excellent for boxes and rectangular crates, but it would be unsatisfactory for upright hampers and tomato

baskets. The length, width and height of the bed should be carefully planned to accommodate the packages to be hauled without loss of space. Improvised racks or shel-

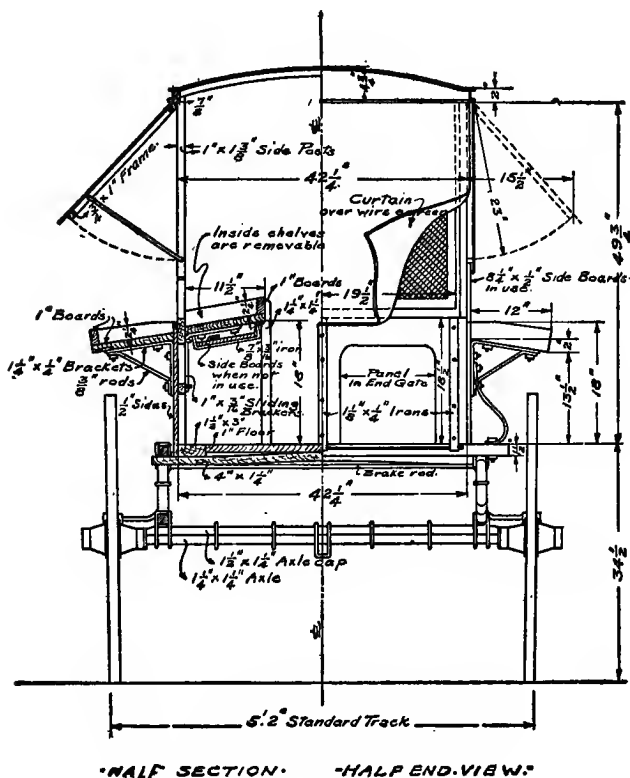

FIG. 55. RETAIL WAGON

ings are necessary in the transportation of many kinds of packages. Moderately low platform wagons are the most serviceable. All wagons should be washed fre-

quently and painted as often as necessary to keep them looking bright. A neat wagon, tastefully painted and lettered, attractive horses and harness, draw attention and command the respect of other classes of business men.

231. **Auto-trucks.**—Market gardeners and truckers in various parts of the country are beginning to use auto trucks for delivering vegetables. This form of transportation is especially desirable for long hauls and when

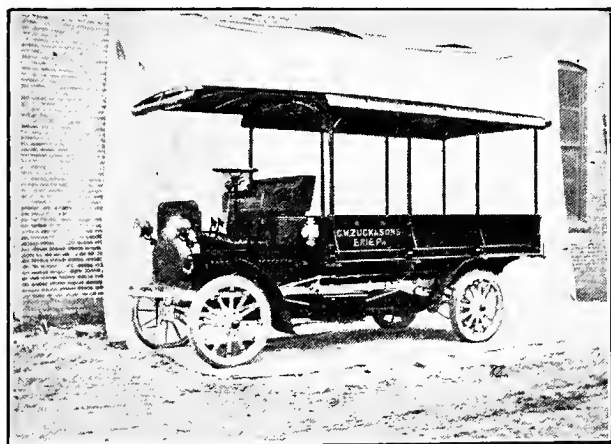

FIG. 56. AUTO DELIVERY TRUCK USED IN ERIE COUNTY, PA.

the roads are good and comparatively free of steep grades. The increased speed is an important factor, not only in reaching the market, but in making quick deliveries after the market has been reached. The cost of maintenance is probably no greater than for a heavy team and a good wagon. Figure 56 shows an auto truck used by a grower in Erie County, Pa.

232. Transportation by rail.—Enormous quantities of vegetables are transported by the steam railways of the country, shipments being made by freight and express. It is common to find solid trains of a single kind of vegetable moving toward the great centers of population. A prevailing practice for local shipments of miscellaneous vegetables is for the train crew to distribute cars in the forenoon and to collect them on the return trip to the city in the afternoon.

For summer shipments the cars must be iced or well ventilated. Refrigeration is universally employed for long distances, and when the distance is very great re-icing may be necessary to insure the delivery of the vegetables in first-class condition. In the winter, cars must be properly insulated to prevent the freezing of vegetables. The trolley is becoming an important means of transporting garden crops.

233. Transportation by water.—Boats are used to a considerable extent in the transportation of vegetables. At Norfolk, Va., many truckers own gasolene boats, which are used in carrying produce to the large steamers. Loading proceeds all day, and in the evening the steamer departs for a northern market with its thousands of barrels or other packages. Refrigeration is also used if necessary on the steamers, and is accomplished by placing the ice over the packages, or at the sides of the ship if the produce must be protected from the melting ice. Water transportation is regarded as highly satisfactory and the freight rates are usually lower than by rail.

An extensive market gardener at Orient, Long Island, uses several boats in delivering vegetables. Figure 57 shows one of the smaller sizes. A large dock house has been built on this farm, and it is also used in storing supplies, such as fertilizers and packages brought in by boat.

234. Selling to the consumer.—When a limited area is cultivated it is often an advantage to sell direct to the

consumer, because the gross receipts will be larger than when selling at wholesale. The most common methods are to sell from house to house or in a city retail market. When either of these plans is used, it is mainly a question whether the time of man and team when thus engaged are worth more than when employed at home in giving the crops better care or in cultivating a larger area. It is doubtless true that many gardeners minimize

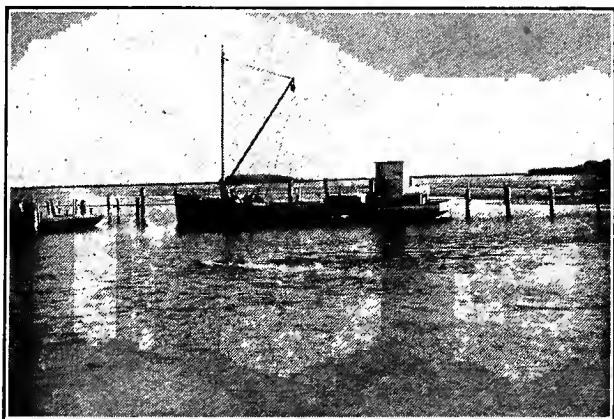

FIG. 57. MOTOR BOAT USED BY A LONG ISLAND MARKET GARDENER

profits by spending too much time seeking buyers of small lots.

When selling from house to house it is imperative that the goods be first-class in every particular, and thus make it possible to build up a regular trade. To retain customers it is also important to make trips every week throughout the year. It may be necessary to go daily in the summer and from one to three times a week at other seasons. Since consumers must not be disappointed,

promptness and regularity count for much in retaining trade. A variety and a succession of vegetables are important factors, whatever the method of selling may be.

Retail wagons should be built especially for the purpose (230). A covered wagon for the protection of salesman and vegetables is highly desirable. A Minnesota gardener's wagon is provided with a gong, and the salesman also furnishes his customers with large printed cards placed in the windows whenever vegetables are wanted. With the cards and the gong very little time is lost in getting buyers to the wagon.

Many cities have retail markets where farmers and gardeners are privileged to place their wagons and sell to the consumers. When this method is followed the gardener should always occupy the same place so that regular customers will know just where to find him. It is not so important to carry an assortment of vegetables. It is often an advantage to make a specialty of a few which may be grown to a high degree of perfection. The gardener will soon become well known for these particular crops.

Some gardeners living in the suburbs of cities sell large quantities of vegetables in the field or in the packing shed. The plan is satisfactory, provided waiting on the customers does not interfere too much with the work that may be in progress.

H. B. Fullerton of Long Island has developed a plan of shipping to consumers in large cities, mainly New York. Figure 50 shows the Long Island hamper packed with an assortment of vegetables. The two layers of three 4-quart baskets are separated by a division rack. Before packing, thin paraffin paper is cut in sizes large enough to line the boxes and to lap over the top and cover the vegetables. An assortment of about nine vegetables is sent in each hamper. After business has been established with a family, a preference is often expressed

for certain vegetables, and not more than three to five vegetables may be included in subsequent shipments. The aim, however, is to supply city consumers with an assortment of vegetables just as good, clean and fresh as country people enjoy. Early in the spring the hampers are packed with lettuce, radishes, spinach, rhubarb and root crops held over winter. Later, many other vegetables are available, and a full and varied assortment is furnished as the season advances. The hampers are loaded on express trains in the morning and reach the city home in time for dinner. The uniform price the year round is \$1.50 a hamper delivered.

235. Selling to retailer.—There are four methods of supplying retailers. (1) To sell to stores or marketmen; (2) to ship to city retailers; (3) to sell in a wholesale market and (4) to sell at the farm. By selling to retailers it is possible to operate on a large scale, because there is more time for production and more vegetables can be marketed in the time available. The cost of marketing is much less than when retailing, and the grower can afford to sell for less money.

When driving to local markets it is important to go every day, if possible, and to establish a regular trade with the most extensive retailers. It is also imperative to reach the market early in the morning, in order that the retailers will have ample time to make deliveries for the noon meal. A good wholesale market is the most satisfactory means of supplying retailers, whether merchants or hucksters.

When living too far from the market to drive, a satisfactory shipping business is often built up. Specializing is most profitable when this is attempted. That is, grow one or a few crops of the highest quality and send them to market in such attractive and perfect condition that dealers will consider them indispensable.

236. Selling to wholesaler.—This method of selling makes it possible to operate on the largest scale. The vegetables are hauled to market on big wagons, or liberal consignments are made by train or boat. The grower may cultivate several hundred acres, and ship in car lots, the volume of the business amounting to many thousands of dollars a year. Over 100 cars of cucurbits are produced and shipped annually by a grower on the eastern shore of Maryland.

Vegetables are consigned on commission or sold outright to wholesale dealers. It is sometimes said that all commission dealers are rogues, but this is necessarily far from the truth, although there are rascals among commission men. Rascals have been known to exist also among vegetable growers, judging from the dishonest packs sometimes put up. Many of the most successful gardeners sell entirely on commission, and they stand ready to defend the honesty and integrity of their dealers. Before making a consignment it is important, of course, to investigate thoroughly the reliability of a dealer. Selling for a definite figure is more satisfactory, although it is often impossible to do so without making a sacrifice in price. When shipping to commission dealers the grower should insist upon daily reports by telephone, or when this is not possible, by telegraph. It is a great advantage to converse daily with the dealer, although this is not practicable in many instances, especially if the grower live hundreds of miles away.

A very satisfactory way is to sell to agents at the shipping station. This method has been developed at many points in various parts of the country. It really amounts to an auction without an auctioneer. Agents representing city dealers are authorized to buy as directed. The grower receives cash or a check for the goods sold and goes home without any anxiety concerning returns for the shipment.

237. **Distribution.**—The question of distribution is one of the most important and most difficult problems in commercial vegetable gardening. The main cause of market slumps is uneven distribution. The supply of a given vegetable may be meager in one city and plentiful in another. Were the crops of the country as a whole evenly distributed, slumps and extremely low prices would seldom occur. The individual should do all in his power to prevent crowding the market, but he is practically helpless in most instances. It is a question for organizations to deal with, and it is considered more fully in the next chapter on co-operative associations.

CHAPTER XVIII

CO-OPERATIVE ASSOCIATIONS

238. History.—Co-operative associations among commercial vegetable growers have been developed mainly within the past 15 years, for with the rapid extension of the gardening industry co-operation has become a necessity. In many instances they were organized for the protection of the members against excessive transportation rates and unscrupulous commission merchants, but now the scope has broadened until every phase of marketing is controlled by most of the organizations, and many have taken up other lines of work important to producers.

239. Objects.—The objects of the various associations vary considerably, but as a rule the specific purpose is co-operation in buying and selling, although the work is generally more comprehensive. The constitution of a large and highly successful organization contains the following: "Section I. Its object shall be the buying, selling and handling of produce, the selling and consigning of produce as agent of the purchaser, the inspection of all produce so sold or consigned, and the owning or operating of storage warehouses and packing houses for produce, and generally to deal in all such materials, articles, or goods as in the opinion of the board of directors can be conveniently and advantageously dealt in by the corporation."

240. Character of organizations.—Co-operative associations have been formed for the benefit of all classes of producers. There are many organizations of greenhouse growers. General truckers in various sections, especially southward, are well organized. Growers of special crops

have united for their mutual benefit, forming such organizations as the Long Island Cauliflower Association, and the Thermal Cantaloupe Growers' Association. General organizations, however, are much more common, and some are mammoth affairs, having hundreds of members representing thousands of acres; others are small, having only a few members, although the benefits justify co-operation.

241. Volume of business transacted.—The transactions of organizations like the Eastern Shore of Virginia Produce Exchange and the Southern Produce Company amount to millions of dollars annually. These great co-operative bodies are well known in the principal cities, and are a great advantage in making sales. The annual total shipments of a single kind of vegetable often run into thousands of cars. For example, a Texas association shipped in one year over 3,000 cars of watermelons.

242. Capitalization ranges from a few hundred dollars to \$100,000 or more, depending upon the methods adopted and the magnitude of the organization. The number of shares held by any one person is always limited, and sometimes is adjusted pro rata to the number of acres cultivated. In some instances members are required to give bond for about \$100, and a general manager is selected to conduct the business for 5 per cent on net sales, all office expenses and telegrams being paid by the manager.

243. Management.—The management of an association is in the hands of a board of directors who are chosen because of their extensive operations or peculiar fitness for the work devolving upon them. They employ a manager, who usually gives all of his time to the business affairs of the association. He may work on commission, but the more common plan is to pay him a salary. It takes a keen, shrewd, alert, tactful business man to handle the business of a large organization. He must have

a thorough knowledge of men (producers on the one hand, and buyers on the other), transportation companies and their methods, refrigeration, industrial conditions, cities, supply and demand, centers of production, movement of crops, and dealers in the various cities to be supplied; he must keep in daily or hourly touch with all the great markets in order to avoid gluts and to sell at highest prices. The wires are used with freedom. One well-known organization paid \$10,000 in one year for telegrams.

244. Selling advantages.—It is impossible for an individual producer, living hundreds of miles from market, to sell at as uniformly high prices as an association. He is in the dark as to market conditions; he is busy enough with the production end, to say nothing of finding a market; in many instances he is a poor business man and has a meager knowledge of problems which must be understood by a successful manager or salesman. A competent manager knows where to ship, what to ship and how to ship. Some managers are paid salaries of several thousand dollars. They are masters of the art of selling and of dealing with business men.

245. Savings.—When transactions are made on so large a scale and through one corporation, the savings may amount to thousands of dollars a year; better transportation rates are secured; refrigeration costs less; fertilizers, packages, seeds, implements and other supplies are bought in car lots at the lowest prices; the quality of the supplies is also more satisfactory; seeds may be grown by contract and under inspection of a representative of the association.

246. Fraternal advantages.—Organization brings the growers closer together, and instead of being in competition with each other their interests are mutual; they become more neighborly and the community as a whole enjoys a delightful fellowship. At the same time, the pro-

ducer need not lose his individuality; he may use special methods and mark his produce with his own brand or trade mark.

247. Educational advantages.—Co-operation means better and more intelligent gardeners because of free and mutual exchange of ideas. This is a daily occurrence in organized communities. Jones and Smith meet at the shipping station. Jones has the better watermelons. Smith wants to know how they were grown, and his neighbor is pleased to tell him, because their interests are mutual. Meetings of the association are held from time to time. The strong organizations are able to employ the best talent, and the result is that these meetings or conferences are great educational forces. In some instances the associations have been able to interest the experiment stations in their problems, and have secured special investigations in their behalf.

248. Co-operation relieves the producer.—One of the greatest advantages of co-operation is the fact that the producer is relieved of the strain of selling his produce. This often causes more worry than the growing. The association relieves him of this anxiety, and all of his time and energy may then be devoted to the work of production and the preparation of crops for market. He can give his undivided attention to his work at home, and for this reason his earning power should be practically doubled, while at the same time he is conscious of the fact that the association will get more money for the crops than he could by individual effort.

249. Uniformity in packages, in packing, grading and branding are decided advantages. The careful system of inspection used by organizations reduces to a minimum irregularities in these respects.

250. Distribution.—The earnings from the crops grown in a given section depend largely upon proper distribution. This is one of the greatest objects of organiza-

tion. For example, a car of melons may be shipped from a southern point to Philadelphia. While it is in transit the manager may learn that the hourly arrival of large quantities of melons makes good prices in Philadelphia very uncertain, if not impossible, and the car is sent to a market that looks more promising. Some organizations attract buyers, and sales are made at the shipping station. This is a very desirable plan, for it relieves the association of considerable responsibility and probably results in higher prices. The Ozark Fruit Growers' Association consigned on commission 294 cars of strawberries in one season at an average price of 90 cents a crate. During the same season 226 cars were sold on the track at an average price of \$1.27. This made a difference of 37 cents a crate in favor of the track method of selling. Another season this association sold on commission 272 cars at the average price of \$1 a crate, but the 288 cars sold on the track at \$1.66 a crate, or an increase of 66 cents over the commission method.

251. Constitution and by-laws.—The constitutions and by-laws of associations vary to some extent. Those of the eastern shore of Virginia Produce Exchange may be taken as typical of the best.

CHAPTER XIX

THE STORAGE OF VEGETABLES

252. Does storing pay?—The storing of vegetables often requires a large amount of extra labor in handling the crops; many necessary facilities must be provided; there is always more or less shrinkage of vegetables in storage; risks must be taken, and there may be little or no advancement in price. For these reasons many gardeners prefer selling the bulk of the fall crops direct from the field. Storage, nevertheless, is often an advantage and sometimes a necessity. Prices at harvest are frequently so low that growers are forced to store their vegetables in order to realize a profit. Again, storage may be important in order to satisfy the trade, especially when the grower has established a retail route. From the standpoint of the consumer, storage is of prime importance, because it materially lengthens the seasons when various classes of vegetables are available.

253. The requirements of storage.—Three main factors must be taken into account when providing storage facilities; viz., (1) moisture, (2) temperature and (3) fresh air. No general rule will apply to all classes of vegetables. Some vegetables, as the root crops, must be kept quite moist in order to preserve their plumpness and succulence. On the other hand, excessive moisture should be avoided because it engenders decay. Certain vegetables, as onions and sweet potatoes, must be kept dry to prevent decay. A degree or two above freezing is the most favorable temperature for the safe storage of most vegetables, although there are exceptions. Fresh air is also essential in most instances. (See Chapter XXI.)

254. Harvesting vegetables to be stored.—Many vegetables possess better keeping qualities when placed in storage before they have fully matured. This is particularly true of cabbage and the salad crops. Losses in storage are often due to diseases which have developed in the field. When such infections are known to exist and to be a common source of trouble in storage, the safer course is to dispose of the crop without attempting to preserve it for later marketing. Too much care cannot be taken in handling the crops to be stored, for every bruise invites decay and mars the appearance of the product when placed on the market.

255. Storage houses.—With the rapid expansion of commercial vegetable gardening, storage houses of large capacity have become a necessity. The character of construction of storage houses depends mainly upon the kinds of crops to be stored, and hence there are many types of storage houses. In New Jersey and southward there are many sweet potato houses, large and small, and varying considerably in form of construction; in cabbage districts, houses are built especially for this crop, while the celery and onion growers build houses which they regard most satisfactory for their own specialties. (See Chapter XXI.)

256. Pits and outdoor cellars are used extensively for the storage of vegetables. They are inexpensive to construct and may be built by growers whose operations are not large enough to justify the erection of commodious houses. (See Chapter XXI.)

257. The house cellar.—The cellar of the residence is often used to preserve vegetables. As a rule it provides unsatisfactory conditions, especially if it contains a furnace, because the air is then too warm and dry. These difficulties may be overcome to some extent by separating the furnace room from the storage rooms by brick, stone or concrete walls; the pipes may be covered with asbes-

tos; ample ventilation may also be provided, and vegetables like the root crops may be covered with a few inches of moist soil or sand to prevent withering.

258. Burying is a very common method of keeping vegetables during the winter. It involves more labor than other methods, but when properly managed preserves cabbage and the root crops in the very best condition.

259. Cold frames may be used to advantage in storing vegetables. The drainage around them must be thorough, and mats, shutters or boards must be provided to cover them. An excellent plan is to cover the sash with boards after the frames have been filled, and then to bank the outside of the frames with soil or manure. As the weather becomes severe, straw may be placed over the frames and covered with shutters or boards. This plan is particularly desirable for celery. See notes on celery storage, page 321.

CHAPTER XX

THE CLASSIFICATION OF VEGETABLES

260. Methods of classification.—The grouping of vegetables gives the student a better understanding of the character, requirements and uses of the various crops. The arrangement based solely upon botanical relationship is the most exact system, but in many cases is of little advantage in helping to determine the best cultural conditions for each crop. The uses of the plants also constitute an important basis for classification. All vegetables may be placed in two general groups in respect to their hardiness, viz., (1) "tender" plants, or those which are injured or killed by frost, and which require high temperatures for successful growth, as tomato, pepper, eggplant, bean, melons, squash, cucumber, sweet corn and sweet potato; (2) "hardy" plants, or those which are not injured by frost, many of them in fact bearing severe freezing and thriving at temperatures too low for "tender" plants. The "hardy" crops include pea, cabbage, kale, spinach, asparagus, rhubarb, celery, lettuce, cress, radish and many other plants. The line, however, between "tender" and "hardy" plants is largely arbitrary. Celery, for example, is properly classed with hardy plants, while comparatively light frost or low temperatures may check the growth of young plants and cause them to produce seed shoots. The onion is also regarded as a hardy plant, while seedlings of certain varieties are injured by light frosts.

The best system of classification has been devised by Prof. L. H. Bailey ("The Principles of Vegetable Gardening," pp. 240-242), and is followed in this chapter. ~~It is based primarily upon methods of culture, although~~

~~other factors are considered.~~ The system provides for two general classes; namely, annual vegetables and perennial vegetables. These classes are then divided in subclasses according to the uses of the crops, and each subclass is composed of groups, determined mainly by their cultural requirements. ~~The scheme of classification proposed by Professor Bailey is as follows:~~

CLASS I. ANNUAL VEGETABLES

SUBCLASS I. CROPS GROWN FOR SUBTERRANEAN PARTS.

Group 1. Root Crops.

- Beet (*Beta vulgaris*).
- Carrot (*Daucus carota*).
- Celeriac (*Apium graveolens*).
- Chicory (*Cichorium intybus*).
- Horse-radish* (*Cochlearia armoracia*).
- Parsnip (*Pastinaca sativa*).
- Radish (*Raphanus sativus*).
- Salsify (*Tragopogon porrifolius*).
- Turnip and Rutabaga (*Brassica*).

Group 2. Tuber Crops.

- Sweet potato (*Ipomoea batatas*).

Group 3. Bulb Crops.

- Cive or Chive (*Allium schoenoprasum*).
- Garlic (*A. sativum*).
- Leek (*A. porrum*).
- Onion (*A. cepa*, *A. fistulosum*).
- Shallot (*A. ascalonicum*).

SUBCLASS II. CROPS GROWN FOR FOLIAGE PARTS.

Group 4. Cole Crops.

- Broccoli (*Brassica oleracea*).
- Brussels sprouts (*B. oleracea*).
- Cabbage (*B. oleracea*).
- Collard (*B. oleracea*).
- Cauliflower (*B. oleracea*).

*Horse-radish and dandelion are perennials but usually occupy the ground only one year.

Kale (*B. oleracea*).

Kohl-rabi (*B. oleracea*).

Group 5. Pot Herbs (used for "greens").

Beet (*Beta vulgaris*).

Chard (*B. vulgaris*).

Dandelion (*Taraxacum officinale*).

Mustard (*Brassica* species).

Sea kale (*Crambe maritima*).

Spinach (*spinacea oleracea*).

Group 6. Salad Crops.

Celery (*Apium graveolens*).

Corn salad (*Valerianella olitoria*).

Cress (*Lepidium sativum*, *Barbarea vulgaris*, *Nasturtium officinale*).

Endive (*Cichorium endiva*).

Lettuce (*Lactuca sativa*).

Parsley (*Carum petroselinum*).

SUBCLASS III. CROPS GROWN FOR FRUIT OR SEED PARTS.

Group 7. Pulse Crops.

Bean (*Phaseolus*, *Dolichos*, *Vicia*).

Pea (*Pisum sativum*).

Group 8. Solanaceous Crops.

Eggplant (*Solanum melongena*).

Pepper (*Capsicum annuum*).

Tomato (*Lycopersicum esculentum*).

Tomato, husk or strawberry (*Physalis*).

Group 9. Cucurbitous or Vine Crops.

Cucumber (*Cucumis sativus*).

Gherkin (*C. auguria*).

Muskmelon (*C. melo*).

Pumpkin (*Cucurbita*).

Squash (*Cucurbita*).

Watermelon (*Citrullus vulgaris*).

Group 10. Corn, Okra, Martynia.

Martynia (*Martynia proboscidea*).

Okra (*Hibiscus esculentus*).

Sweet corn (*Zea mays*).

Group 11. Condimental and Sweet Herbs.

Dill, mint, sage, savory, tansy, thyme and many others.

Group 12. Mushroom.

Not discussed in this book. It is more generally regarded as a forcing crop.

CLASS II. PERENNIAL VEGETABLES.

Artichoke, globe (*Cynara scolymus*).

Artichoke, Jerusalem (*Helianthus tuberosus*).

Asparagus (*Asparagus officinalis*).

Rhubarb (*Rheum rhaponticum*).

Sea kale (*Crambe maritima*).

261. Requirements of the various groups.—Root crops (Group 1) thrive at comparatively low temperatures. They usually prefer sandy loams, and deep soils are also important for long-rooted crops. Sandy types of soil favor symmetrical development of roots and decrease the percentage of the small, fibrous roots objectionable in this class of vegetables.

TUBER CROPS. (Group 2.) The sweet potato requires a long season and high temperatures. Sandy soils are preferred.

BULB CROPS (Group 3) are hardy and may be grown successfully in many soil types, although sandy loams are best. They do not require high temperatures, but the soil must be well provided with humus and available plant food.

COLE CROPS (Group 4) are hardy and require a cool season, a fertile soil and an abundant supply of moisture.

POTHEB CROPS. The requirements of the "greens" (Group 5) are variable. (See Chapter XXI.)

SALAD CROPS (Group 6) are hardy. They require liberal feeding and an abundance of moisture.

PULSE CROPS. (Group 7.) Soil and weather requirements vary with each crop.

SOLANACEOUS CROPS (Group 8) are "tender" vegetables

that must not be planted in the open until there is no danger of frost.

CUCURBITOUS OR VINE CROPS (Group 9) are "tender" vegetables that require high temperatures and usually a long season, Sandy loams preferred.

CORN, OKRA AND MARTYNIA. (Group 10.) High temperatures are necessary for the best results. The soil should be moist and fertile.

PERENNIAL VEGETABLES. The soil should be enriched annually by the application of rotten manure. Nitrogenous fertilizers are especially beneficial.

Although the foregoing method of classification is exceedingly valuable, the requirements of crops, even in the same group, are so variable that a complete discussion of each crop is necessary to give accurate cultural directions. The vegetables are taken up in alphabetical order, because this arrangement makes the book most convenient for reference.

CHAPTER XXI

CULTURAL DIRECTIONS

ARTICHOKE—GLOBE (*Cynara scolymus*)

262. **Uses.**—The globe artichoke is seldom found in American gardens. The edible parts are the base of the flower heads and the midribs of the large blanched leaves; the latter are called chards. The flower head scales must be cut when young and tender. They are generally eaten raw, although they may be boiled and served as "artichoke salad," or cooked and pickled.

263. **Culture.**—The globe artichoke is hardy, but requires some protection during the winter in most northern sections. It is easily propagated from seed or suckers, or by division of roots. If the seeds are sown under glass in March, and the young plants pricked into pots before setting in the open, edible heads may be cut the first season. If the seeds are sown early in beds out of doors the plants should be set in the field the following spring. Some gardeners prefer to propagate from suckers, because plants from seeds show great variation.

This vegetable thrives in any rich, moist, but well-drained garden soil. The rows should be not less than 3 feet apart and the plants spaced 2 feet in the row. For the best results the plantations should not be retained more than two or three years. Some growers keep them only one year; when maintained for more than one season, the old plants are cut back to the ground in the fall and the ground mulched with 5 or 6 inches of coarse manure. In fields started from suckers or potted plants edible heads should be produced from early spring until frost in the fall.

ARTICHOKE—JERUSALEM (*Helianthus tuberosus*)

264. **Uses.**—The Jerusalem artichoke is produced to a very limited extent for American markets. It is native to the northern part of the United States and to parts of Canada. Although the tubers, which constitute the edible part, are regarded as equal to the potato in nutritive value, the taste is not relished by most people. They may be served boiled, pickled or cooked for salads. The tubers are most valued for stock feeding. Hogs are especially fond of them and are sometimes privileged to harvest the crop.

265. **Culture.**—This vegetable does well in poor soil, but responds to liberal feeding. Sandy loams are preferred. Under favorable conditions the plants are said to yield 500 to 1,000 bushels an acre. The tubers may be planted whole, or cut into one to three-eye pieces, in the same way that potatoes are prepared for planting. Planting very early in the spring is essential to heavy yields. The rows should be about 3 feet apart, and the tubers or cut pieces 15 to 18 inches apart in the row. As soon as the tops are dead the crop may be dug, or left in the ground all winter without danger of injury by freezing.

ASPARAGUS (*Asparagus officinalis*)

266. **History.**—The edible species of asparagus is indigenous to temperate Europe and Asia. History records its culture at least 200 years before the Christian era. The Romans and the Greeks not only prized this vegetable for food, but all parts of the plant were highly valued for their medicinal properties. The shoots were often dried by the ancients, and, after soaking in hot water, only a few minutes were required in cooking. This method of preservation is still used in Europe, and to some extent in the United States. At least 400 years ago the peasants of France, Holland, Germany, Hungary

and England gathered the tender shoots of the wild plants and sold them at the market places. For many hundreds of years stalks of mammoth size have been grown by gardeners in various countries. Asparagus has been a popular vegetable in America ever since the earliest settlements were established. It was doubtless introduced by seeds or plants brought from European gardens.

267. Botany.—There are about 150 species of the genus *Asparagus*, which belongs to the lily family. Although the shoots of a few other species are edible, *Asparagus officinalis* is the only one that has found a prominent place in the vegetable gardens of the world. The hardy, branching herbaceous plants are 3 to 7 feet high. The numerous filiform branchlets and the very fine delicate foliage make the tops valuable for decorative purposes. While the plant is herbaceous, the root stock or crown is perennial, making an annual growth of 1 to 3 inches. This extension is practically horizontal, although the rootstock or crown rises nearer the surface of the ground each succeeding year. The horizontal roots are fleshy, $\frac{1}{8}$ to $\frac{1}{4}$ inch in diameter and light colored. The small feeding rootlets form on the large succulent roots, and the latter gradually become hollow and die and are replaced by new roots.

Hexamer ("Asparagus," by F. M. Hexamer, p. 15) gives the following description of the flowers and the berries: "The asparagus flowers are mostly solitary at the nodes, of greenish-yellow color, drooping or filiform, jointed peduncles, perianth, six-parted, campanulate. Anthers, introrse; style, short; stigma, three-lobed; berry, red, spherical, three-celled; cells, two-seeded. While the flowers are generally dioecious—staminate and pistillate flowers being borne on different plants—there appear also hermaphrodite flowers, having both pistils and fully developed stamens in the same flower."

268. Importance.—Asparagus is universally regarded as one of the most important vegetables. The home garden is not complete without it, and our markets are demanding a larger supply every year. It is grown in nearly all parts of the civilized world, but in France, Germany, Holland, England and the United States enormous quantities are produced for commercial purposes. It is said that more than 3,000 people are employed in the asparagus plantations near Paris. In the United States the enterprise has been developed to the greatest extent in New Jersey, California and New York, while it is an important crop in nearly every other state.

From early March until August this vegetable may be found on our city markets, and the forced crop is available to some extent throughout the winter. Nearly everybody enjoys this vegetable. Formerly it was regarded as a luxury; now it is a necessity. Notwithstanding the large increase in acreage, thousands of towns and small cities are poorly supplied with this delicious and wholesome vegetable.

The flavor and quality of asparagus may be preserved remarkably well by canning. Immense quantities are grown for this purpose, especially in California and on Long Island. For canning blanched "grass" is preferred, and large size of shoots counts for just as much in getting good prices as when they are sold on our markets. The factories often purchase by weight, paying from \$80 to \$200 a ton.

269. Varieties.—Nurserymen and seedsmen catalog many kinds, but there are no complete botanical descriptions of American varieties. It is doubtful whether we have more than three or four distinct varieties, although there are doubtless many strains showing more or less variation.

PALMETTO is unquestionably the leading American

variety. A large proportion of our growers claim that no argument can be advanced for planting anything else. It is prolific, producing large shoots of good quality. It originated in the South, and is generally popular in the southern states, but it is largely planted in all other parts of the United States. The plants are more resistant to rust than any other variety, and this, undoubtedly, is the main reason for its popularity.

ARGENTEUIL is a French variety, planted extensively around Paris and to a considerable extent in the United States. It has attracted wide attention in this country, and has given excellent results on many farms. Argenteuil has not done well on soils containing much clay or silt. There are two types, known as the Early and the Late Argenteuil.

CONOVER'S COLOSSAL was originated by Abraham Van Sicklen of Long Island and introduced by S. B. Conover, a produce merchant of New York. It is the oldest and best known American variety, but has been supplanted very largely by newer varieties.

BARR'S MAMMOTH was originated by Crawford Barr of Pennsylvania. It is regarded as an excellent variety and finds ready sale on the Philadelphia market.

DREER'S ECLIPSE is fairly popular, and is valued for its large and tender shoots.

COLUMBIAN MAMMOTH WHITE, introduced by D. M. Ferry in 1893, is a favorite with some growers on account of the large, light-colored shoots.

Other varieties planted to some extent are Donald's Elmira, Hub and Moore's Cross-bred.

270. Climatic requirements.—The asparagus plant seems to be well adapted to all temperate regions. While the most extensive plantations are usually at low altitudes and near large rivers or large bodies of water, their success is probably due more to favorable soil conditions

than to climatic influences. This crop has been grown successfully in all parts of the United States, regardless of diversified climatic conditions.

271. Soils.—Asparagus is grown successfully on a great variety of soils. It is generally admitted, however, that the deep, rich, moist, sandy loams provide the best conditions, although alluvial soils are valued. In the large plantations of Orange County, Cal., peat mixed with sand has given excellent results. Shoots of enormous size are produced in this region. But whatever the texture of the soil is, asparagus demands a liberal supply of humus, good drainage, also an abundant and constant supply of moisture. In a noted plantation of New Jersey the water table is only 3 feet from the surface. With this never-failing supply of water in co-operation with a rich sandy soil the results are highly satisfactory. Sandy soils are especially important for the growing of blanched asparagus, because it is very difficult to produce straight shoots and also troublesome to ridge and cut under ground in heavy, clay soils. Stones interfere seriously with the growth of the shoots, prevent thorough tillage, make ridging difficult and are especially annoying when cutting the shoots beneath the surface of the ground. Southern, southeastern and southwestern aspects are preferred by experienced growers, because they produce earlier crops than northern slopes. They also suffer less from drouth, and the soil is not transported as much by driving winds.

272. Seed selection.—The most successful asparagus growers of the old world have for centuries practiced seed selection. The experts of several hundred years ago may have possessed limited knowledge of the laws of plant breeding, but they evidently realized the importance of careful selection, and knew enough to select seed that would produce spears of enormous size. In the United States the growers who far excel the average in net returns to the acre invariably use selected seed, which

they consider as important as high fertility and thorough tillage.

Large size and superior quality count for more than anything else in securing remunerative prices. These objects, therefore, should be paramount in the mind of the grower who would select his own seed. Vigor of stock is also essential, and it may be an advantage to take earliness into consideration.

Experienced gardeners seem to agree that the best seed is not produced until the plants are at least four years old. A greater age is sometimes recommended. The prospective plants for seed production are studied carefully for a season or several seasons, perhaps, and the observant grower finally decides upon certain ones that approach his ideals. They are free from rust, or practically so, the shoots are large and surpass the average plant in number. To be even more accurate, and certain of getting seed from the most prolific plants, some of the most promising specimens may be marked and numbered and the cuttings of each weighed for a season or two. It is just as important to choose high-grade male plants as it is to choose the best female plants. There may be several female plants to one male and they should be in close proximity to each other to insure thorough pollination. A stake should be driven at each plant to serve as a mark the following spring. The spears from all other plants in the field are cut and marketed as usual and only two or three stalks retained on each breeding plant. This limitation of stalks will produce stronger plants and larger seeds. Six to 10 inches of the tops and the ends of the branches should also be cut off to favor the development of better seed on the lower part of the plant, and if there is a profuse setting of berries, it is an advantage to remove some from the extremities of the plant.

The seed should not be harvested until fully ripe. When gathered in wholesale lots without the careful selection which has been described, the plants are cut, hung in the dry for a few days and then threshed. The chaff is next removed and the berries soaked in water for a day or two when the skin and the pulp may be readily removed by the use of a wooden block, followed by successive washings. Carefully selected seeds are stripped from the plants by hand, soaked for a day or two and the pulp removed by rubbing the berries between the hands or by the gentle use of a wooden block, after which they are washed, thoroughly dried and stored as other dry seeds. In the process of washing, the heavy seeds sink, while the light ones float and are poured off with the shells and the pulp. Further selection of large, plump seed may be made by screening with a mesh of proper size.

273. Propagation.—It is universally conceded that a strong one-year-old crown is superior to older crowns. The roots of two-year plants are seriously mutilated when dug, and the younger plant becomes established more quickly and grows more rapidly. The best cultural conditions must be provided to grow strong crowns in a single season.

The richest garden soils should be selected for this purpose, and the seed sown in the spring as soon as the ground can be prepared. As the seed germinates very slowly, an early start is important to have the benefit of a long season. If hand wheel hoes are to be used, the rows should be not less than 15 inches apart; while for horse tillage 30 inches is not too much space. A pound of plump, fresh seed should produce at least 3,000 plants. The propagator should aim to have a strong plant every 2 inches, though 3 inches apart in the row is better spacing to produce the most vigorous crowns.

Thinning is often necessary to prevent crowding and the production of weak plants. As the small plants are

very delicate, the depth of covering over the seed should not be more than $1\frac{1}{2}$ inches to insure germination. Since asparagus seeds germinate very slowly, a few radish seeds should be sown with them to mark the rows, so that tillage may begin as soon as the radish plants appear. The button-shaped radishes should be used because they will be ready to pull in four weeks or less and may be removed without any detriment to the asparagus plants. The most thorough tillage should be given the nursery plat throughout the season. Nitrate of soda can generally be employed very effectively, by applying as a top dressing at frequent intervals during the summer. One hundred pounds an acre may be applied each time, sowing broadcast or along the rows.

The Missouri Experiment Station recommends sowing the seeds in hotbed or greenhouse during February or early March, transplanting the best when 3 inches high into small pots. Later the plants are shifted into larger pots, so they may make a good start before being set in the field. By this method very strong plants are secured the first season, and a larger percentage of marketable shoots become available during the early life of the plantation.

Asparagus may also be propagated by dividing the crowns. This method, however, is not satisfactory and it is seldom, if ever, practiced by commercial growers.

274. Plant selection.—In seed production, the importance of selecting proper plants, then the best berries on the chosen plants, and, finally, the large, plump seeds, has been emphasized. Selection again plays an important part when seedlings are chosen for the new plantation. The possibility of rigid selection is one of the main arguments advanced by the Missouri Station for the pot method of propagation. Professor Whitten urges liberal sowing, because seven-eighths of the seedlings should be discarded. In regard to selection he recom-

mends that as asparagus plants vary more than almost any other vegetable, only those plants which have the thickest, fleshiest and most numerous stems be chosen for potting. "Many that appear large and vigorous will have broad, flat, twisted or corrugated stems. Discard them. Beware, also, of those that put out leaves close to the soil. These will all make tough, stringy, undesirable plants. The best plants are those which are cylindrical, smooth and free from ridges. They shoot up rapidly, and attain a height of 2 inches before leaves are put out. They look like smooth needles. This matter of selecting the best plants for potting and subsequent planting out, is of the greatest importance in asparagus culture."

The principles of selection have been discussed. One-year plants are better than two. Whatever the age, it pays to select plants with four to eight large stems. Several times as many seedlings should be grown as will be actually needed for the new plantation. When propagated in the field, the selection should be made in the fall before the stems break down. The plants may be tied together in bundles of 50 and stored under proper conditions until spring. Very satisfactory conditions are furnished by packing in barrels with slightly moist sand or sawdust and burying the barrels late in the fall, first covering with straw or leaves and then adding a few inches of soil. If proper methods of seed selection have been practiced, it should not be difficult to sell the surplus plants at good prices.

The consensus of opinion is that male plants are more productive than female. Experiments made at the Ohio Station (Ohio Station Bul. 9, Vol. III) gave results as expressed in the table which follows.

PRODUCT FROM FIFTY PLANTS EACH, MALE AND FEMALE

	Product from 50 male plants oz.	Product from 50 female plant oz.
First period, 10 days.....	37	21
Second period, 10 days.....	104	68
Third period, 10 days.....	266	164
Fourth period, 10 days.....	203	154
Total for the season.....	610	407

“This shows a gain of the male over the female plants of 76 per cent for the first period and a fraction less than 50 per cent for the whole season. Reversing the standard of comparison, it will be seen that the female plants fall below the male 43 per cent for the first period and a little more than 33 per cent in the total. In no case did the female plants produce equally with the male.”

The difficulty with any method of propagation is that the sex of the plant cannot be determined until the plants produce flowers, and this does not occur until the second season, when the plants are universally regarded as being too old for the most successful transplanting. It is possible that the increased productiveness of male plants would overbalance the disadvantages that result from shifting the plants a year later than is approved by our best growers. Then, too, the one-year plants might be set temporarily in a special plat, with at least a foot between plants in the row, so they could be moved later with considerable soil to permanent quarters.

275. White and green asparagus.—When rows of asparagus are ridged to the usual height, the shoots must make an additional growth of 5 to 10 inches before they reach the light, and if cut as soon as the tips appear above ground, the product is known as white “grass” or white asparagus. If the ridge is slight or only a few inches high and the spears cut at or only a few inches

below the surface of the ground, the product is known as green "grass," or green asparagus.

In deciding which of these two kinds to grow the following facts should be considered: (1) There is a great difference of opinion regarding the two types. Greiner ("How to Make the Garden Pay," p. 143) says, "It is true that the lower end of each white stalk is apt to be somewhat tough and needs peeling and perhaps shortening, but the flavor is decidedly milder, and of a more refined character than that of the stronger flavored green stalks." A very extensive and highly successful grower of green shoots describes their flavor as "extremely delicate." Probably nine-tenths of American growers use only the green shoots on their own tables. (2) The stalks diminish in size after they reach the surface of the ground and, therefore, it takes more plants to produce a bunch of green stalks than of white. This difficulty can, without doubt, be overcome to a great extent by skillful seed and plant selection. (3) The demand for the green product is rapidly increasing. Our markets are paying better prices for green, and this possibly offsets the lighter production to the plant. (4) As the soil is not needed for ridging in growing green shoots, the rows may be planted much closer, thus increasing the yield to the acre. (5) High-grade white spears can be grown only in sandy soils, while there is no such limitation with the unblanched shoots. (6) It is more difficult to control beetles in growing green shoots, because the stalks are more exposed to their attacks.

Whatever points may be raised for or against each type, it is unquestionably true that green shoots are becoming more popular in all sections.

276. Soil preparation.—When it is realized that the asparagus plantation is to last 10 years or longer, too much thought and care cannot be given to the preparation of the soil. In the famous fields of France a com-

mon practice is to trench the soil to the depth of 2 or 3 feet before planting and to work in large quantities of manure. Formerly, trenching was popular in this country, but it has been abandoned among commercial growers. A study of the habit of root growth has led to the conclusion that little if anything is to be gained by unusually deep preparation.

Subsoiling is seldom practiced by commercial growers, and it is of doubtful permanent benefit. The soil should not be plowed deeper than its natural depth, but there should be complete pulverization to the full depth of the plow furrow. To accomplish this a disk or a cutaway harrow can be used repeatedly to advantage before plowing. This treatment is especially important when sod lands are to be planted. After plowing, the same types of harrows should be employed until the ground is in perfect condition. While it is customary to plant land that grew other vegetables the previous year, some of the most successful growers prefer to precede the asparagus plants with clover sod. The crop has been known to thrive remarkably well planted on land which has produced alfalfa for several years.

277. Fertilizing.—Earliness, high quality and large size are the factors that count for the most in securing remunerative prices, and liberal and intelligent feeding bear a direct relation to each of these requisites. The gardener expects a great deal of his asparagus plants; he wants them to produce salable shoots for two months or more and then recuperate sufficiently to yield a good crop the next year.

When starting a new field the plants should have all the food they can utilize. Soon after setting, 800 pounds of a 5-8-10 fertilizer should be applied along the rows, and a top-dressing of nitrate of soda used at intervals of three or four weeks. Rotten manure can be used profitably before planting. A similar treatment should be

given the second year. The plants should then be well established and a different course of treatment given.

The supply of vegetable matter must be maintained. This may be done by applying annually 10 to 15 tons of stable manure to the acre. Much larger amounts were used some years ago, but more economical results have been attained by reducing the application of stable manure and increasing the amount of commercial fertilizers.

Manure may be applied in the fall, early in the spring or at the close of the cutting season. It is doubtful, however, whether application should ever be made in the fall, and there is a growing inclination to make such applications after the cutting season, rather than in the spring. All kinds of stable manures are satisfactory for asparagus. They should be applied between rather than directly over the rows. It is believed that mulching with manure over the rows is objectionable because of the tendency of the manure to draw the crowns of the plants nearer and nearer the surface. Furrows are often opened with a one-horse plow to receive the manure. This practice is questionable, because the plow necessarily breaks and mutilates a great many roots. The better practice is to broadcast the manure as evenly as possible between the rows, and to mix it with the soil, by the use of a disk or a cutaway harrow.

Very few garden crops can be fertilized as heavily as asparagus and a profit be made on every dollar expended for plant food. Many of the most successful growers believe that the largest net returns cannot be realized without an annual investment for plant food of \$60 to \$80 an acre. Stable manures have been practically abandoned by some growers, but the safer practice is to apply them liberally enough to maintain the supply of humus. From one to three tons of commercial fertilizer an acre may be employed advantageously on established beds.

There has been much discussion as to the character of

the fertilizer adapted to this crop. According to analyses made by Wolff, a ton of fresh sprouts contains 6.4 pounds of nitrogen, 1.8 pounds of phosphoric acid and 2.4 pounds of potash. The best fields produce at the rate of three tons an acre, and this would require 19.2 pounds of nitrogen, 5.4 pounds of phosphoric acid and 7.2 pounds of potash. It is very evident that the shoots themselves do not abstract large amounts of plant food. To meet these needs it would take only 128 pounds of nitrate of soda, 38 pounds of 14 per cent rock phosphate and 14 pounds of muriate of potash. Now, why do expert growers feed their plants with such great liberality? Because other factors besides the mere production of shoots must be taken into account. The enormous root system and the tons of tops renewed every year must be supported. Again, growth of both shoots and tops must be very rapid, and consequently there must be no shortage in the supply of quickly available plant food.

Nearly all growers agree that nitrogen is the most important element of plant food for asparagus, and while the majority of them believe that it should be applied in the form of nitrate of soda, some growers prefer organic material, as dried blood, tankage, fish scrap or cottonseed meal. As to the best commercial fertilizer to use, investigators and practical growers differ widely in their recommendations. Voorhees suggests the basic fertilizer, 4-8-10, supplementing with heavy applications of nitrate. Rolfs recommends 4-5-7. An expert New Jersey grower uses a 6-7-5 formula. Many practical growers prefer 5 or 6 per cent of nitrogen.

The proper time of application is a much disputed question. As the leaves or elaborating organs are not permitted to develop until after the cutting season, it is argued by some that the proper time to apply nearly all of the plant food, both stable manure and commercial fertilizer, is after the cutting season, when the leaves are

formed. Voorhees and others believe that the plants are benefited by early spring applications, especially if green shoots are produced. On the other hand, we must not lose sight of the fact that next year's crop is mainly dependent upon this year's top and root development. Large tops and strong roots mean heavy shoots next year.

If seeds and plants have been selected intelligently and all cultural conditions are favorable, the following treatment should give excellent results: Apply 10 to 15 tons of fine manure early in the spring, or probably with as much benefit immediately after the cutting season; one and one-half tons of a 4-8-10 mixture, half applied in early spring and half immediately after the last cutting; 150 pounds of nitrate of soda by broadcasting as soon as growth begins in the spring; 150 pounds of nitrate of soda when the cutting season is half over; 150 pounds of nitrate of soda at the close of the cutting season and the same quantity one month later.

Common salt was used in large amounts on asparagus beds until quite recently. It possesses no fertilizing value, and although it draws some moisture and is injurious to weeds, its use is no longer considered an advantage by successful commercial growers.

278. Planting distances.—When the most intensive methods are followed, the rows are made closer together than when the crop is grown on a large scale. It is held by many growers that close planting necessarily results in smaller shoots, but this is not the case with skillful intensive gardeners. More space between rows is obviously required when high ridging is necessary to grow the white shoots, although French producers of white spears plant as closely as most American growers of green shoots. Wide planting is also favorable to convenient cultivating, and plants and roots will not begin to crowd so soon. Therefore the plantation should be profitable during a longer period of years. On the other

hand, wide planting materially limits returns for several years, and for this reason there is some tendency to plant closer and make new beds more frequently.

Planting distances vary considerably in different sections. In the growing of white stalks, the average spacing in England is probably 16 inches by 4 feet; in France, 2 x 4 feet; in Germany, 3½ x 4 feet; in the largest fields in California, 2 x 9 or 10 feet (on reclaimed land); in New Jersey, 2 x 5½ feet; in New York, about 2 x 5 feet. In New Jersey green asparagus is usually grown 2 or 2½ x 5 feet; at Concord, Mass., 2 x 4 feet; in Pennsylvania, 2 x 4 or 4½ feet. An extensive grower in Philadelphia County, Pa., plants 4 x 4 feet, while an intensive grower at Cleveland, O., plants 1 x 3 feet. Peter Henderson recommended 9 inches by 3 feet.

279. Planting.—Fall planting is occasionally practiced, but spring planting is universally regarded better. After the ground has been plowed and thoroughly harrowed, deep furrows must be made preparatory to setting roots or crowns. If the land is steep enough to wash, the furrows should run at right angles to the direction of the slope; if practically level, north and south will insure the most even and perfect distribution of light on all parts of the row. The depth of the furrow should be determined mainly by the natural depth of the soil. In America the crowns are set 6 inches to 1 foot deep, but 8 inches is considered deep enough, although 10 inches may be an advantage. Certainly, the crown should never be set in the subsoil, where the fleshy horizontal roots would fail to find food or proper physical conditions. Deep planting is regarded as important in the production of large shoots, but the chief advantage is to get the crowns beyond the reach of tillage implements. As the new buds form higher on the crown each year, deep planting, therefore, prolongs the time when there will be any interference by tillage tools. The first shoots will not be quite

so early in the spring when the crowns are set deep, but many advantages overbalance this possible disadvantage.

After having decided upon the distance between rows, an ordinary moldboard plow is used to make the trenches for planting. A furrow slice is thrown on each side of the furrow. It is often necessary to make two or three rounds before the proper depth has been obtained. Then shovels are sometimes employed to secure greater depth. When trenched and ready to receive the plants, the field has the appearance of having dead-furrows at frequent intervals. Unless companion crops are to be grown between the rows, cross marks should be made so that the cultivators may be used both ways. A pole with a series of chains attached at the required distance is sometimes used in marking, though more accurate methods are preferred.

It is not best to set the plants in the bottom of a hard trench. Instead, spread the roots over a slight mound of fine soil and then cover the crown with 2 or 3 inches of fine moist soil. The ground should be well firmed over the fleshy roots. The planter may accomplish this by the use of his feet as he rises and proceeds to the next plant. Inexperienced growers often make the mistake of covering the crowns too deeply at first, thus smothering the small shoots before these reach the surface. No more soil should be filled in the trench until the shoots appear. Then soil is gradually worked in mainly by cultivation. By midsummer the furrows should be filled.

Some writers advocate starting fields from seed sown where the plants are to remain. While the system possesses certain advantages, it has not met with favor among extensive commercial growers.

280. Cultivation.—Following the planting of the new bed or the field, tillage should begin promptly after the first rain. Light raking in the furrows will be sufficient tillage at first, but after the plants have started, wheel

hoes or one-horse cultivators are employed. Care must be exercised in cultivating to prevent breaking, injuring and covering the young plants. One-horse cultivators are doubtless the best implements for most conditions, although other types of implements are employed in various sections.

Cultivation should begin early in the spring and continue as long as it is possible to get between the rows with horse tools in order to keep down the weeds and maintain soil moisture. Some hoeing may be necessary during the cutting season, although the proper use of the weeder will reduce the amount of hand labor. If the weeder is used during the middle of sunny days, when the plants are not so rigid, very few shoots will be broken or injured.

In established fields either the disk or the cutaway harrow should be used to break and pulverize the surface soil in the spring as soon as the ground is dry enough. Manure may also be incorporated with the soil at this time. Following harvest, one of these tools should be employed after the fertilizer or the manure has been applied. In old fields harrowing will necessarily injure some of the buds, but the benefit is so great that the operation is justifiable.

Ridging to a greater or less extent is practiced in nearly all plantations, not excepting fields producing green shoots. Plows, disk ridgers or other special tools are used to perform this work in the spring after the ground has been harrowed. Ridging is not usually practiced until the spring of the third year. The ground is always leveled at the close of the cutting season and one-horse cultivators are employed as long as it is possible to get between the rows. In a few weeks after the last cutting the ground will be completely shaded and the weeds cannot make much progress. No tillage tool which will seriously break or mutilate the roots should ever be used in asparagus fields.

281. **Harvesting.**—There is an increased tendency to cut a small percentage of the shoots the second year. The majority of growers regard it a mistake to cut before the third year, and yet there are examples of growers harvesting \$50 worth of shoots an acre the second year without any apparently injurious effect upon the cuttings of subsequent years. The cutting season of the third year should not continue longer than three or four weeks. It is well understood, of course, that the renewal of the shoots is an exhaustive process, and it is possible to reduce materially the vitality of the crowns by cutting too severely. It is true, however, that the average length of the cutting season is longer today than ever before. Formerly, it was thought that the plants would not stand a cutting period of more than six or seven weeks. Then the period was lengthened to eight weeks, and now nine is common. Successful growers sometimes cut for 10 or 11 weeks, but this is possible only when the season is very early and beds or fields are in prime condition. Whenever the shoots begin to show weakness it is certainly time to stop cutting. In the North, harvesting generally begins during April and continues until June 15, or two to three weeks later. If the bed is to be abandoned, cutting can be continued in the summer as long as the crop pays.

In foreign countries the shoots are nearly always removed with the hand, breaking them neatly without injury to other shoots and without leaving a stub to decay. In this country, special tools have been devised for the purpose. The point of the knife is shoved down the shoot the required distance, the handle moved from the stock to form the required angle and the knife then thrust through the shoot. As asparagus bunches vary from 7 to 10 inches in length the cutting of the shoots must be regulated accordingly. Then, too, the height of blanching and con-

sequently the depth of cutting under ground must be regulated by market demands. White "grass" is cut just as soon as the tips appear. Green "grass" may be cut at the ground or there may be a compromise, cutting 2 to 4 inches below the surface. Many growers who claim they are selling the green product are really offering a compromised article.

In very cool weather it may not be necessary to cut more than twice a week, but when the season is well advanced and the weather is warm, this work must be attended to daily and sometimes twice a day to prevent loss. It is a general practice to cut late on Saturday afternoon in order to avoid Sunday cutting. The cutting of Saturday is bunched and placed in shallow trays containing about $\frac{1}{2}$ inch of water. In this way it may be kept in perfect condition until Monday morning when it is sent to market. Every shoot, large and small, is cut unless some are reserved for seed purposes or for lure plants, on which poison is placed to destroy beetles.

The shoots after being cut are usually placed on piles and then collected in baskets or in carts. Some growers believe that time is saved by placing the shoots as fast as cut in strong, flat baskets which may be collected rapidly and hauled to the packing house. These baskets hold from 8 to 10 pounds. The actual cost of cutting in an 18-acre field in New Jersey averaged $1\frac{1}{2}$ cents a bunch.

282. Marketing.—Asparagus shoots may be washed before or after bunching. Although both methods have their advocates, it is pleasanter to handle the washed stalks, and cleaning may be done more thoroughly before bunching. Careful grading is of greater importance than with most other garden crops. Most growers make three grades; namely, extra, prime, and second, while a fourth (culls) makes it possible to grade more perfectly.

Special devices known as "bunchers" are in general use. The bunches vary from 6 to 9 inches in length and

are usually $4\frac{1}{2}$ inches in diameter, weighing from 2 to 3 pounds. Nine-inch bunches are probably most popular on eastern markets. They should weigh not less than $2\frac{1}{2}$ pounds. The number of stalks to the bunch varies from a dozen to two or three dozen. Eighteen shoots to the bunch has been the average on one of the largest places in this country.

The bunches must be tied firmly near the top and near the bottom. Strong jute and raffia have been used extensively, but red tape, $\frac{1}{4}$ to $\frac{3}{8}$ inch wide, is now in general use, because it attracts attention and conveys the idea that the product is of superior quality. Figure 58 illustrates a bunch tied with red tape ready for market.



FIG. 58. ASPARAGUS
BUNCHED FOR MARKET

Standing the bunches in shallow trays of pure water, as previously described (281), is often an advantage during the week, as well as in holding over Sunday. The product may be held in perfect condition for several days by this plan, which may also be the means of avoiding a glut or of meeting a special demand. The shoots soon take up sufficient water to make the bunches tight and they also increase somewhat in length.

The crop is hauled to local markets in all sorts of packages. Second-hand berry crates and carriers are often used for shipping. This is a mistake. The most successful extensive growers use crates made for the purpose. These are generally made to hold two or two and one-half dozen bunches, and are deep enough for the bunches to stand erect without injury to the tops. The "Southern Crate" is 28 inches long, 22 inches wide and 9

inches deep, outside measurements. The ends are $\frac{7}{8}$ -inch pieces and the side slats $\frac{3}{8}$ of an inch thick and $4\frac{1}{2}$ inches wide. This crate holds thirty $4\frac{1}{2}$ -inch bunches. For long shipments, damp moss should be placed in the bottom of the crate and the bunches should always be packed firmly to carry well. In California the shoots are not bunched, but packed loosely, usually in 40-pound boxes, sold by weight.

283. Yields and returns.—Two thousand bunches an acre is considered a good yield, and is probably somewhat above the average. Yields at Concord, Mass., have run as high as 3,400 bunches an acre. An extensive grower in New Jersey has been averaging about 2,500 an acre, and another grower in the same state has been doing somewhat better. Prices are variable. Ten dollars a dozen bunches is received sometimes for the fancy extra grade early in the season, but prices generally range from 15 to 35 cents a bunch, and 20 cents is a fair average price, after deducting commission and transportation charges. An expert grower shipping to Boston, New York and Philadelphia sold \$5,000 worth of asparagus from 10 acres in one season. The gross income from small areas often exceeds \$500 an acre, while half this is regarded satisfactory by the majority of gardeners. When modern methods are applied asparagus is unquestionably one of our most profitable vegetables.

284. The age of plantations.—There are asparagus beds in England, and probably in this country, more than half a century old. It is not uncommon to find beds 20 to 30 years old producing profitable crops. In all such cases, however, there has been great reduction in the size of shoots and the crop is nearly always sold on local markets, which are not discriminating. After the plants are 8 to 10 years old, the size of the shoots diminishes rapidly, unless unusual conditions are provided. Fifteen years is the limit of satisfactory production in most large

fields, and many growers prefer to destroy the old plants when they are 10 to 12 years of age. The field should be devoted to other crops for a year or two before replanting in asparagus.

285. The common asparagus beetle (*Crioceris asparagi*) is by far the most troublesome of the insect enemies of asparagus. Both the larvæ and the beetles feed on the shoots, which are thus lowered in market value or rendered unfit for commercial purposes. They also feed on stems and leaves of old and young plants, which they defoliate and greatly reduce in vitality.

The beetles winter under any convenient shelter and lay eggs for the first brood in April or May. The eggs are deposited in groups of two or more, upon leaves or stems. The larvæ emerge in three to eight days, begin to feed at once and attain full growth in 10 to 14 days. Chittenden ("Insects Injurious to Vegetables") describes the beetle as "a most beautiful creature, slender and graceful in form, blue-black in color, with red thorax, and lemon-yellow and dark-blue elytra or wing covers, with reddish border. Its length is a trifle less than $\frac{1}{4}$ inch." Two and frequently three broods are produced in a season.

Various methods are employed to control this insect. Arsenate of lead is effective in destroying both slugs and beetles. It may be used with safety on young plants, in old plantations after the cutting season, and on lure plants. When shoots are cut every day, and there are no other plants in close proximity, all the eggs are destroyed when the stalks are cut and sent to market. Coops of chickens are sometimes kept in the fields to feed on the beetles and slugs. The plan is considered excellent when properly managed. Fresh air-slaked lime kills the larvæ, and when they are brushed to the ground in hot weather they die before they can get back on the plants.

286. Other insect enemies.—The 12-spotted asparagus beetle (*Crioceris 12-punctata*) is a serious enemy some-

times. It is controlled in practically the same manner as the common asparagus beetle. The Asparagus miner (*Agromyza simplex*) sometimes causes damage. The adult is a small black fly, but the stalks are injured by the maggot, which mines under the skin in the lower part of the stalk. The eggs may be destroyed on lure or trap plants, which are burned in late June or early July.

287. Rust is practically the only disease that has caused any damage to asparagus. It made its appearance in this country in 1896, and has since caused heavy losses in almost all important asparagus-growing districts. Hexamer ("Asparagus," p. 138) describes this fungous disease as follows: "When an asparagus field is badly infested with the rust the general appearance is that of an unusually early maturing of the plants. Instead of the healthy green color there is a brown hue, as if insects had sapped the plants or frost destroyed their vitality. Rusted plants, when viewed closely, are found to have the skin of the plants lifted, as if blistered, and within the ruptures of the epidermis the color is brown. The brown color is due to multitudes of spores borne upon the tips of fine threads of the fungus, which aggregate at certain points and cause the spots. The threads from which the spores are produced are exceedingly small and grow through the substance of the asparagus stem, taking up nourishment and causing an enfeebled condition of the victim, which results in loss of the green color and the final rustiness of the plant, due to the multitude of spores formed upon the surface. These spores are carried by the wind to other plants, where new diseased spots are produced; but as the autumn advances a final form of spore appears in the ruptures that is quite different in shape and color from the first ones produced through the summer. The spores of late autumn, from their dark color, give an almost black appearance to the spots."

Mowing and burning the tops every fall, after they

become brown and lifeless, but before they have become brittle, is universally regarded as the best means of control. Plants of great vigor are not so subject to attack. In seasons of drouth the disease is especially troublesome, and irrigation is considered a means of reducing loss from this malady. Some plants are more resistant to rust than others, and this fact has led to the establishment of a breeding station at Concord, Mass., where investigations and experiments are being made under the direction of the United States Department of Agriculture. It is hoped that new varieties which will be entirely immune from this dreaded disease will be developed.

BEAN (*Vicia, Phaseolus*)

288. History.—The Broad bean (*Vicia faba*), believed to have originated in southwestern Asia, was known in ancient times. It is produced largely in Europe for stock feeding, and also grown to a considerable extent in Canada. It requires cool weather and a long season, and for these reasons the plant does not thrive in the United States. It is valued in Europe and in Canada as a forage crop, and the large flat, angular seeds when ground are used as meal.

According to leading authorities, the common or kidney bean (*Phaseolus vulgaris*), from which all of our field and garden varieties have been derived, originated in tropical America. Although definite knowledge of its nativity has not been ascertained, there seems to be no doubt that many varieties were grown in America before they became generally cultivated in European countries. Beans were commonly grown by the Indians. The early settlers placed a high value upon this crop.

289. Classification.—Kidney beans and lima beans (*Phaseolus lunatus*) are the species of greatest importance in vegetable gardening, while several others are valued for soil improvement, stock feeding or for ornamental purposes.

Various methods of classification have been suggested. Corbett (Farmers' Bulletin 289, pp. 7-8) has proposed the following arrangement, which is satisfactory for all practical purposes: "For convenience in reference and for discussion, beans may be divided into two general groups—'field' and 'garden' beans—which are by no means distinctly separate either in appearance or in characteristics. Each of these groups can again be divided into bush and pole beans. Bush beans of the field type are recognized, for commercial purposes, under three well-marked types, known as kidney, marrow and pea beans, each of which may be subdivided into two groups, colored and white. The garden beans, like the field beans, may be divided into bush and pole types; these again into kidneys and limas, the term 'kidney' in this case including all of the common garden beans whether of one type or another, and this group may again be divided into wax and green pod. The same subdivision may also be provided under pole beans, as is suggested in the following classification:"

CLASSIFICATION OF BEANS ACCORDING TO GROUPS AND TYPES.

Field Beans	Bush	Kidney	{ Colored White
		Marrow	{ Colored White
		Pea	{ Colored White
	Pole or corn hill		{ Colored White
Garden Beans,	Bush	Kidney	{ Wax Greenpod
		Lima	
	Pole	Kidney	{ Wax Greenpod
		Lima Runner (Scarlet Runner)	

Various other terms are used to designate different types of beans. "Snap" refers to beans which may be eaten

with the pod; this class is also known as string beans, although a good string bean is stringless. "Green shell" beans are those which are shelled and used before fully ripe, in distinction from dry shell beans, or those which are allowed to ripen before harvesting and cooking. All green shell beans may be permitted to mature, when they can then be used as dry shell beans.

290. Composition.—All classes of beans possess high nutritive value, due to their large percentage of protein. The following table gives the composition of beans compared with other foods:

COMPOSITION OF FRESH AND DRIED BEANS COMPARED WITH THAT OF OTHER FOODS*

Material	Water	Protein	Fat	Carbo- hydrates	Ash	Fuel value per lb.
Fresh Beans	%	%	%	%	%	calories
String beans	89.2	2.3	0.2	7.4	0.8	195
Shelled kidney beans	58.9	9.4	0.6	29.1	2.0	740
Shelled lima beans..	68.5	7.1	0.7	22.0	1.7	570
Dried beans						
Lima beans.....	10.4	18.1	1.5	65.9	4.1	1,625
Navy beans.....	12.6	22.5	1.8	59.6	3.5	1,605
Potatoes	78.3	2.2	0.1	18.4	1.0	385
Cabbage	91.5	1.6	0.3	5.6	1.0	145
Rolled Oats	7.7	16.7	7.3	66.2	2.1	1,850
Wheat breakfast foods	9.6	12.1	1.8	75.2	1.3	1,700
Lean beef	70.0	21.3	7.9	—	1.1	730
Eggs	73.7	14.8	10.5	—	1.0	720

291. Importance.—All classes of beans are grown extensively for commercial purposes and the home garden is not complete without varieties representing each class. Snap or string beans are grown largely in the southern and Atlantic Coast states for the northern markets and are produced locally for the markets in all parts of the

*Adapted from table, Farmers' Bulletin 221, p. 17.

country. Millions of bushels of dried beans are produced annually by farmers, especially in Michigan, New York and California, while many other states produce large amounts. Most of the dried beans are of the small type, although California grows annually over 1,000,000 bushels of limas. Beans are produced on a large scale for canning, and shell beans occupy an important place in the operations of some commercial gardeners.

292. As soil improvers.—As the bean is a legume, and consequently a nitrogen-gathering plant, it occupies a prominent place in the commercial garden from the standpoint of soil improvement. It is a great advantage to be able to remove a profitable cash crop and to leave the land in better condition for subsequent crops. The bean, then, is a soil-improving rather than a soil-impoverishing crop. In recognition of this benefit, beans are sometimes planted in preference to more profitable crops which exhaust the soil to a greater extent. When snap or shell beans are grown, no part of the plant is removed except the pods and their contents, and in such instances the improvement in soil fertility should be especially marked. Because of their power to improve soils beans should be used more generally as inter-tillage crops. (See Chapter XXIII.)

Dr. B. D. Halstead of the New Jersey Experiment Station has observed that the tubercles are much more numerous on bean roots in old land than in new, and that the successive cropping of this legume increases the number of tubercles and also the yield of beans. While mention is made of the unsuccessful use of commercial cultures to secure more thorough inoculation, it is highly probable that soil from old bean fields, applied at the rate of 300 to 500 pounds an acre to land where beans have not been grown, would make nodule formation more active and yields larger. The results of many experiments in inoculating for alfalfa and other legumes would sug-

gest the application of lime before spreading the soil on the land to be cropped.

293. Keys and descriptions.—The twelfth annual report of the Missouri Botanical Garden, pp. 81-165 (also published in separate pamphlet form under the title of "Garden Beans"), and Bulletin No. 260 of the Cornell Experiment Station, give comprehensive keys to cultivated varieties and complete botanical descriptions of varieties grown in the United States.

294. Varieties of Dwarf Wax-Podded Beans:

BURPEE KIDNEY was introduced in 1906, and is regarded as one of the most valuable varieties.

GERMAN BLACK WAX, also known as Saddle-back, Saddle-back Wax and by other synonyms, is planted extensively.

WARDWELL KIDNEY WAX, introduced 25 years ago, is a large flat-podded variety, which is popular on many markets. The pods are very attractive.

PENCIL-POD BLACK WAX, the best of the black wax group, is desirable for home use or for market.

IMPROVED GOLDEN WAX is grown extensively and is sold under a dozen or more names, but often referred to as the Rust-Proof Golden Wax.

295. Varieties of Dwarf Green-Podded Beans:

BLACK VALENTINE is extensively grown and is especially popular in the South. It closely resembles Red Valentine, but is more stringy and fibrous.

BURPEE STRINGLESS is said to be listed by at least 140 seedsmen. C. D. Jarvis says (Cornell Bulletin 260, p. 197) concerning it: "One of the most popular and widely grown varieties. Compared with Giant Stringless, it has a smaller pod, is less depressed between beans and slightly darker in color. Burpee Stringless makes up in quality for that which it lacks in appearance. It is slightly susceptible to disease, but otherwise hardy. Because of its reliability, productiveness and good quality it is one of the best both for home use and for market."

RED VALENTINE is the most extensively grown green-podded variety. The pods are produced in large clusters on erect plants. It is very prolific and reliable and an excellent shipper; used extensively for canning and pickling and for general commercial purposes.

REFUGEE is an old reliable variety, hardy, vigorous and productive, and used largely for canning.

296. Varieties of Green Shell Beans:

GODDARD is regarded the best green shell bean of the class known as the "dwarf horticultural." It is an excellent midseason variety.

DWARF HORTICULTURAL is better known than Goddard, but the latter is superior to it in every particular.

297. Varieties of Wax-Podded Pole Beans:

GOLDEN CARMINE, the best of the pole wax-podded varieties, originated in 1904, and is not so well known as older varieties. The pods are large and equally valuable for snap or green shell purposes and desirable for home use or for market.

GOLDEN CLUSTER is better known than Golden Carmine, but is regarded as inferior.

298. Varieties of Green-Podded Pole Beans:

CREASEBACK is the best early pole bean for snap purposes. It is moderately productive, fleshy, very brittle and of fair quality.

KENTUCKY WONDER is the most extensively grown green-podded pole variety, although C. D. Irish (Cornell Station, Bul. 260, p. 225) states, "It is not sufficiently productive, attractive nor resistant to be generally recommended."

LAZY WIFE, known in many localities as White Cranberry, is valued for its stringless pods of high quality. It is an excellent general purpose late variety.

299. Varieties of Pole Lima Beans:

LEVIATHAN is one of the best varieties of pole limas. It is early and desirable for home use and market.

IDEAL is a large-seeded lima, vigorous, a good climber and quite productive.

KING OF THE GARDEN is largely grown and a valuable general-purpose lima.

300. Varieties of Bush Limas.—There are two classes of limas; namely, the small (*Phaseolus lunatas*) and the large (*P. lunatas macrocarpus*). There are pole and bush representatives of each class.

HENDERSON is the best known and most widely cultivated bush or dwarf variety of the small type.

FORDHOOK is the most popular variety of the large bush limas. Other varieties of this class are Burpee, Dreer or Kumerle, Wonder and Burpee Improved. Of this class, Burpee was the first variety introduced. It originated with Mr. Asa Palmer, of Kennett Square, Pa. Bush beans are now generally grown where soil and climatic conditions are suitable. A long and warm season is required for full success.

301. Varieties of field beans.—There are four distinct types of field beans. Professor John W. Gilmore has prepared the following key to the group:

KIDNEY, seed 1.5 centimeters or more in length, more or less reniform; ratio—length, width, thickness, 1-.4869-.3731.

MARROW, seed between 1 and 1.5 centimeters in length. Thickness exceeding half the length, 1-.6537-.6029.

MEDIUM, seed 1 to 1.2 centimeters in length. Thickness less than half the length, 1-.678-.4975.

PEA, seed .8 centimeters or less in length, not reniform, 1-.7467-.6096.

C. D. Irish ("American Varieties of Beans," p. 163) recommends the following varieties of the field class for shell purposes: Of the *kidney* type, White Kidney, Prolific Pickler and Red Kidney; of the *Marrow* type, Vineless Marrow, White Marrow, Aroostook and China Red Eye; of the *Medium* type, Burlingame; of the *Pea* type,

Navy and Snowflake. The pea and medium types are grown the most extensively; their earliness is a great advantage when the crop is to be followed by wheat.

302. Climatic requirements.—Probably the bean is more widely distributed than any other cultivated vegetable. It is grown in nearly all parts of the world. In tropical countries certain species grow luxuriantly and produce abundantly, while the coldest agricultural sections grow certain hardy species or varieties with success.

Notwithstanding these facts, beans exhibit great differences in their power to withstand heat and cold. The seeds of some decay more quickly than others when the soil is cool and moist. Some are more tender to frost than others. All vary greatly in the length of time required to reach maturity. Hot, dry weather often blasts the flowers, and an excessive amount of moisture in soil or air when the crop nears maturity is objectionable. In deciding what to plant, each type should be considered in reference to the existing climatic or temperature conditions. No class of beans will stand more than a slight frost, but bush beans are more hardy than pole varieties and may be planted slightly earlier. All varieties of limas are very tender and require a long season, while many dwarf varieties of snap beans are ready for use in six to eight weeks from planting. Varieties of the same class also vary considerably in hardiness.

303. Soils.—The first requisite of soil is thorough drainage; the second is a moderate amount of organic matter. Some varieties of beans will grow and mature light crops in poor soils, but high fertility is essential to large yields.

Beans are grown successfully in all types of soils. This is especially true of the dwarf garden varieties. Some of the best early crops are grown on distinctly sandy soils, while satisfactory yields are common on sandy loams. The light sandy soils are especially important for lima

beans. Gravelly loams frequently produce excellent crops, but require a large amount of humus. Clay loams are unquestionably the best for the field class of dry beans, and there seems to be a consensus of opinion that all varieties representing this group have a preference for limestone soils. When early maturity is an important factor, sandy soils or sandy loams with southern aspects are most valuable. Muck soils are not satisfactory, because they produce an excessive growth of plant and a meager crop of beans.



FIG. 59. BEANS INTERCROPPED WITH STRAWBERRIES
AT NORFOLK, VIRGINIA

304. **Rotation and soil preparation.**—In New York and Michigan the field varieties are usually grown in a three-year rotation—clover, beans and wheat. A heavy inverted clover sod provides the best conditions for a large yield. The Michigan Station recommends a four-year rotation, in which case alsike clover and timothy seed should be mixed with red clover, so the land can be pastured for one season. Corn is often used in a four-year rotation, when the order of cropping is clover, corn, beans and

wheat. In trucking and market gardening, the garden varieties may be worked into the system of cropping at almost any point, provided there is a sufficient time for the beans to attain marketable size. As this crop must not be started until the ground is thoroughly warm, there is often opportunity to grow early spring crops, such as lettuce and radishes, before planting beans. In the trucking sections of the South, snap beans are often planted after kale or spinach, and the beans are removed in ample time for starting fall crops.

Early spring plowing is especially important when sod land is to be used. The soil should then be harrowed several times before planting to destroy weeds and to conserve moisture.

305. Fertilizing.—It is generally conceded that the mineral elements are of greatest importance in the growing of beans. This is unquestionably true with the field class and late-maturing varieties which have the entire season to provide themselves with nitrogen from the atmosphere. In the districts where dry beans are grown extensively, it is seldom that more than 2 per cent of nitrogen is used in the fertilizer. Many farmers omit this element altogether. Some producers of field beans apply six to eight tons of stable manure an acre and the mineral elements are used quite freely.

In trucking and market gardening, fertilizers are generally employed that contain high percentages of the three elements. Voorhees ("Fertilizers," p. 269) suggests 500 to 600 pounds an acre of a 4-8-10 mixture, supplementing if necessary with 20 to 30 pounds of phosphoric acid and 60 to 75 pounds of potash. While potash is regarded essential, experiments in Mississippi show that the addition of kainit lowered rather than increased the yield of snap beans. The same station recommends 125 pounds of cottonseed meal (or its equivalent), 62.5 pounds of nitrate of soda and 250 pounds of acid phos-

phate an acre. The Georgia Station secured the highest yield of Valentine beans by applying 400 pounds of acid phosphate, 100 pounds of nitrate of soda and 100 pounds of muriate of potash. Several experiment stations have found potash highly beneficial, while phosphoric acid has made the best showing in tests made at most institutions. Unless the soil requirements are definitely known, the only safe course is to apply a complete fertilizer carrying a fair percentage of each element.

Various methods are used in the application of fertilizers for beans. Drilling or broadcasting after plowing is the most common plan. Fertilizer is often applied along the rows with side distributing machines. Hill applications of manure as well as fertilizers are frequently made for pole beans.

306. Selection of seeds.—The selection of high-grade seeds is significant. When a small quantity is to be saved, pods may be chosen from the most vigorous and the most productive plants. It is especially important to avoid anthracnose by intelligent seed selection (317). Nearly all the beans sold for seed purposes by American seedsmen are grown in this country. The prices paid the growers for seed beans of most dwarf varieties vary from \$1.30 to \$2.50 a bushel. Seedsmen base their contract prices on a yield of 8 to 12 bushels an acre, while much larger yields are often secured (315). Nearly all the seed lima beans are grown in California; prices range from \$2.75 to \$4.00 a bushel.

307. Planting Field Beans.—Early planting is not recommended for any of the varieties of field beans. The objections are: (1) There is danger of the seeds rotting before germinating; (2) if the plants appear too soon frost may catch them; (3) early plantings are more likely to rust than later plantings; (4) cold, wet weather may stunt the plants, cause an uneven start and consequently a lack of uniform maturity. It is always better

to wait until the ground is thoroughly warm and when there is little danger of damaging weather conditions. The kidney group may be planted the earliest, followed by the marrows and then the pea varieties. In New York the kidneys may be planted the latter part of May, and the pea varieties from June 5 to 20.

Spacing distances between rows range from 24 to 34 inches, 28 being most popular. Some investigators believe the largest yields are obtained when the beans are 4 to 6 inches apart, while the usual distance is from 2 to 4.

The depth of planting should be regulated by the character of the soil; in heavy soils 1½ inches is ample, while 2 to 3 is not too deep in the lighter soils. For planting, one-half bushel of the smaller beans an acre is the most common allowance, while some farmers prefer three-fourths of a bushel; from 4 to 6 pecks of the kidney varieties are used an acre.

Field beans are usually planted with grain drills. Either 9 or 11 tube drills may be employed. The operation is explained by the Michigan Station (Michigan Station Bulletin 259, p. 91) as follows: "One of the best machines for planting beans is the ordinary 11-drill grain seeder with 7-inch spaces between the tubes. Stop up all the tubes except the 2d, 6th and 10th and let the drill wheel follow in its own outer wheel mark instead of in the last drill mark, as in sowing grain. This will plant three rows at a time, 28 inches apart, which is about the proper distance. In planting the larger varieties of kidney beans, a bean attachment or special bean drill should be used. Some makes of grain drills have attachments for planting beans." Press wheels on the tubes are valuable to secure a uniform depth of covering and an even stand. Field beans are sometimes grown in hills, but drills are favorable to larger yields.

308. Planting dwarf, snap and green shell beans.—Earliness is an important factor in the culture of snap

beans and both home and commercial gardeners are usually willing to take some risks in getting an early start. The first planting may be killed by frost; but if it escapes the home gardener will be pleased, and the commercial grower will probably be well rewarded. If some of the plants are damaged or killed, those which have escaped may make a profitable crop.

For hand or wheel hoe cultivation the rows are often planted 16 to 18 inches apart; for horse tillage, 30 inches is satisfactory, although many growers prefer more space.

Beans are usually planted with corn drills by the use of the bean plate. Bean "spotters" are also employed to some extent. These drop three or four beans to the hill, the hills being about 8 inches apart. This method of planting gives better opportunity for hand hoeing and is said to increase yields. When planted in drills the beans are 2 to 4 inches apart and covered with 2 inches of soil or less in many instances. No more soil should be used in covering than will insure sufficient moisture for germination. The amount of seed used to the acre varies from $\frac{3}{4}$ to $1\frac{1}{2}$ bushels, depending upon the size of beans and planting distances, but 1 bushel an acre is probably most used.

309. Planting pole beans.—Pole beans are generally planted in hills, 3 x 4 or 4 x 4 feet apart. The poles are placed at the time of planting. (See Section 311 for notes on methods of supporting.) The hills are often raised a few inches to secure good drainage. Four to six beans are planted in each hill, and then thinned if necessary.

310. Planting lima beans.—All varieties of lima beans are very tender and must not be planted until the ground is warm and there is no danger of frost. Pole varieties may be grown in hills or in drills, and in the latter case supported by wire (311). The planting distances for

pole limas are the same as for pole, snap or shell beans.

Limas are sometimes started in hotbeds or greenhouses, in which case the seed should not be sown longer than four weeks in advance of field planting. Pots or berry baskets may be used for this purpose. They should be filled with light, rich soil and about four beans planted in each pot or basket. By this method the plants may be set in the field without any disturbance of the roots, and edible beans should be obtained at least two weeks sooner than from field plantings.

311. Supporting pole beans.—Poles ranging in length from 7 to 9 feet are generally used for the support of climbing varieties. The bark is left on them, as the rough

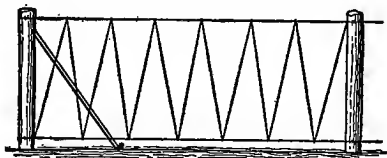

FIG. 60. WIRE TRELLIS FOR BEANS

surface is an advantage to the twining plants. They are placed at the time of planting. If kept under cover when not in use, they will last several years.

Various forms of wire supports are used when the beans are planted in drills. This method of support is regarded as an advantage by many growers. Some home gardeners prefer the heavy types of poultry netting, especially for lima varieties. An excellent plan, although more troublesome than the pole method of support, is to plant and brace fairly heavy posts at the ends of the rows with lighter posts at intervals of 20 feet, the posts extending 5 or 6 feet above ground. A No. 10 wire is stretched over the tops of the posts, and another near the ground. The two wires are connected in a zigzag manner with light twine, as shown in Figure 60.

312. Cultivation.—If hard rains occur, causing the soil to bake before the seeds have germinated, the crust should be broken by the use of a weeder. This tool is also used to some extent after the plants are up. Some of the plants may be destroyed, but this is not objectionable if the stand is very good. The least damage to the plants will be done if the weeder is used in the middle of the day, when the stems and leaves are not so rigid.

Thorough tillage is essential to large yields. The weeds must be controlled and the moisture conserved. As the bean is a shallow-rooted plant, deep tillage should be avoided, for it results in root pruning, which is always detrimental to the bean plant. Implements with a large number of narrow teeth or shovels are best adapted to the cultivation of this crop. In the culture of field and garden types on a large scale, riding cultivators are commonly employed. When the plants are small, shields should be used on the cultivators to prevent covering them. The culture should be level until the last cultivation, when wings should be used to throw up a slight ridge for the support of the plants.

There is an almost universal agreement among practical growers and plant pathologists that this crop should never be cultivated when the plants are wet from dew or rain. The Cornell Station (Cornell Station Bulletin 255) comments as follows in regard to this matter: "Cultivating or working beans when wet should be avoided as much as possible. On this point there can be no dispute. The character of the parasite causing the disease and the practical experience of the growers everywhere show that this recommendation is correct."

313. Harvesting.—Garden beans must be picked by hand. When grown on a large scale a great many pickers are required. Colored labor is used almost entirely for this work in the South. Figure 61 shows a large force harvesting a crop of wax beans at Norfolk, Vir-

ginia. The pickers of snap or string beans are generally paid a definite amount a basket.

Field beans were formerly harvested by pulling, but the special harvesters now employed materially reduce the cost of this operation. L. C. Corbett (United States Department of Agriculture, Farmers' Bulletin 289, p. 14) describes it as follows: "This implement is built on the principle of a pair of shears, and consists of two long steel blades mounted upon a strong framework carried upon wheels. The long shearlike blades are set to cut the roots of the plants just beneath the surface of the



FIG. 61. PICKING STRING BEANS AT NORFOLK, VIRGINIA

ground. Above these blades guard rods or guide rods are so arranged as to move from their original positions the plants whose roots have been severed and, since the implement is designed to cut two rows of beans across the field, the plants of two rows are thrown together in a single windrow. This clears space for the passage of one of the animals in the team, so that it is necessary for only one to pass through the standing crop, thus decreasing the amount of loss by shelling which would result from both animals being driven through the standing crop."

After cutting, the rows may be thrown together into small piles for curing, or they may be moved into windrows by side-delivery rakes. The crop is allowed to ripen fully in the field, so that only a few days after cutting are required for curing. If the weather is wet, the piles must be turned frequently to prevent damage to the beans. After thorough curing the crop is stored in barns after the manner in which hay is handled, and threshed whenever it is convenient, but not until cool weather. The old method was to flail, while now bean threshers are generally employed. These machines are moved from farm to farm, just as grain threshers or separators are used.

314. Marketing.—In the districts producing large amounts of field beans the threshed product is delivered by the farmers at elevators or special bean houses managed by dealers who attend to the work of cleaning, grading and picking. In Michigan there are over 200 bean elevators provided with the best machinery for preparing the crop for market. While the machines remove most of the dirt and broken beans, some hand picking is necessary to get the crop thoroughly cleaned. To facilitate this tedious work a machine spreads the beans thinly on a revolving broad belt, which passes slowly before the picker. The speed of the belt is controlled by the person removing the defective beans. Girls and women are employed extensively to do this work, some houses maintaining a force throughout the year. Dealers who contract for the crop, generally furnish bags to the farmers free of charge.

String or snap beans are often sorted before marketing to remove broken or damaged pods. They are generally carried in bushel hampers and shipped by express and refrigerated freight, a car holding about 600 hampers. The hampers should be well filled and the pods

as fresh and plump as possible. Half-bushel baskets are often used for local markets.

Green shell beans are usually marketed in berry baskets in both pint and quart sizes. Green shell limas are regarded as quite a luxury and usually command good prices.

315. Yields and returns.—In 1900 the average yield of field beans in the United States was 11 1-5 bushels an acre. The most successful growers often obtain double this yield. The price varies considerably, but ranges from \$1.50 to \$2 a bushel. Snap beans should produce 200 bushels an acre, although the yield is often less. A net return of \$100 an acre, after deducting freight and commission charges, is regarded as satisfactory. Prices vary greatly from year to year, and the net profits some seasons are not encouraging.

316. Bean weevil (*Bruchus obtectus*).—While the bean has a number of insect enemies, the weevil is the most destructive. This insect is about $\frac{1}{8}$ inch long and covered with fine brown, gray and olive pubescence. Oviposition begins in the field, where the female deposits eggs in holes in the pods made by the jaws or by the drying and splitting of the pods. Breeding continues after storage, a large number of individuals frequently developing in a single bean. The beetles emerge the following spring to repeat their work of destruction.

Field treatment of any kind has not been satisfactory, so that preventive measures before planting must be employed. Fumigation with bisulphide of carbon is the most effective treatment. The New Hampshire Station (N. H. Bul. 59) recommends the following plan: "Use an ordinary coal oil barrel, which will hold close to five bushels of beans. This can be treated with 3 ounces of bisulphide of carbon, which may be poured on the beans. Care must be taken to close the top tightly; the exposure should be for 48 hours. The bisulphide should

be of the best quality because this will vaporize without any residue. The vapor of this substance is very inflammable and the work should, therefore, be done at a distance from other buildings and no light of any kind be brought near."

317. **Anthracnose** (*Collectotrichum lagenarium*) is the most common and the most destructive of the bean diseases. It is a fungous disease, which attacks all parts of the plant except the roots. Diseased seed is often the source of the malady. The young tender stems may become affected and the plants killed when conditions are favorable for the parasite; or it sometimes appears later on the pods, as well as on other parts of the plant. The disease is very noticeable on the yellow pods of wax varieties, which are reduced in value or rendered unfit for market purposes. Figure 62 illustrates the diseased pods. The Cornell Station (Cornell Station Bulletin 255, p. 436) makes the following statement in regard to this disease: "The spots or cankers are black with reddish or yellowish margins. Most growers are also familiar with the disease on the seed itself, especially on the white beans, where it makes rusty, red spots of various sizes, sometimes involving nearly the entire seed, though ordinarily only producing a slight discoloration on one side. The disease enters the seed by way of the pod, the fungus penetrating from the outside into the young and tender seed. . . . When the diseased seeds are planted in the soil, and first come through the ground, they are sure to show the small black cankers on the cotyledons or seed leaves and a little later on the stems."



FIG. 62. BEAN ANTHRACNOSE

Numerous investigations have been made pertaining to the control of bean anthracnose. Seed treatments of various kinds and spraying have been tried, but with unsatisfactory results. The planting of healthy seed is unquestionably the best preventive measure. If seed and soil are free from the disease, there can be no anthracnose. Seed selection, then, is of prime importance, and the matter should have closer attention among both home and commercial growers.

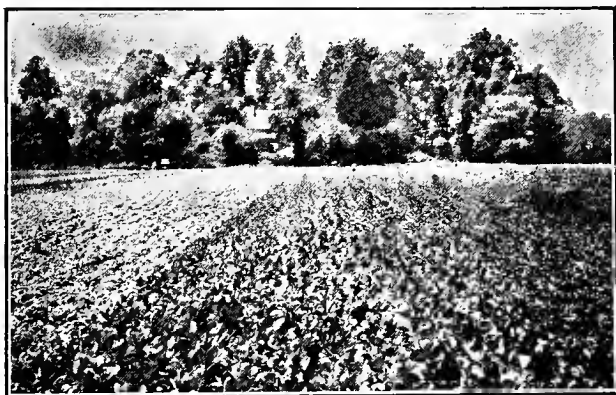

FIG. 63. FIELD OF GARDEN BEETS

BEET (*Beta vulgaris*)

318. History and importance.—The plant from which the various types of beets have been originated is native to the seacoast of South Europe. Cultivated forms have been grown for more than two thousand years. The beet is an important vegetable in European countries and is largely grown in America, where soil and climatic conditions are suitable. The vegetable is especially valuable to market gardeners who follow the most intensive

systems of cropping. (See Figure 63.) The fleshy leaves of the garden type are used extensively for greens and the roots are valued for pickling or for cooking.

319. Soil.—There are very few American gardens in which beets are not grown to some extent for the home table. While this is true, certain soil characteristics are essential when the enterprise is to be undertaken on a large commercial scale, especially when the product is to be sold on an open market in competition with beets grown under ideal conditions.

Although oval and turnip-shaped beets are shallow feeders, a fairly deep, moist, but well-drained soil is apparently necessary for all varieties. The sandy loams are best suited for this crop, especially when earliness is an important factor. When grown in heavy soils the beets besides being unsymmetrical in form, develop a large number of fibrous laterals, objectionable from both market and culinary standpoints. Clover sods, green manures and stable manures greatly improve the physical condition of heavy soils, but in such soils beets cannot be expected to produce as fine roots as in soils better adapted to them. Favorable market conditions, however, may make the crop remunerative under adverse soil conditions.

320. Climatic requirements.—The beet thrives best in the cooler parts of the country; hence the crop is more important in the North than in the South. When planted southward, advantage is taken of the moderate temperatures of early spring. Although the plants are comparatively hardy, frost sometimes injures or even kills the very early plantings and the crop must be harvested and protected before severe freezing weather in the fall.

321. Varieties.—Twenty-three varieties of beets were described by Goff (Sixth Report of the New York Station, pp. 120-132). They are grouped under four general

classes; namely, root oblate or top-shaped, root oval, root half-long and root long-conical. Each of these classes is divided into subclasses based on color—red or yellow. The four types of beets which have been developed from *Beta vulgaris* are common garden beet, sugar beet, mangel or mangel-wurzel, and swiss chard, which last is used for greens. The following varieties of garden beets are the most important:

CROSBY EGYPTIAN, a very early and valuable blood turnip variety; extensively grown.

ECLIPSE, extra early, round and smooth; top small; flesh intense red and high in quality; popular for home use and market.

EARLY MODEL, a very early round beet of high quality.

EGYPTIAN. Various strains or selections of this variety are offered by seedsmen. It is an early, turnip-shaped beet and largely planted.

EDMANDS BLOOD TURNIP, a round beet, desirable to follow the very early varieties.

BASTIAN BLOOD TURNIP, a turnip-shaped beet, valued for early planting.

BASTIAN HALF-LONG BLOOD, light in color and excellent in quality; a medium early variety.

YELLOW TURNIP, an early, yellow, sweet-fleshed variety.

LONG DARK RED, a long-rooted late variety valued by some people for winter use.

322. Planting.—The beet seed sold in the United States is produced in California, the Middle States, England and France. A small percentage of market gardeners grow their own seed. As the plant is biennial, in order to produce seed the roots must be preserved over winter (325) and planted in the spring as soon as the ground can be prepared. The seed plants grow to the height of about 4 feet and branch profusely; therefore the roots should be planted about 2 x 3 feet apart

With careful, intelligent selection, superior types may be developed and maintained.

The seed of the beet is really not a seed, but a fruit, usually containing several seeds and surrounded by a corky pericarp. These characteristics of the seed should be well understood by planters in order to sow properly. As each so-called seed may produce several plants, care must be exercised to avoid sowing too thickly. The corky covering requires a liberal and constant supply of moisture to insure germination.

The soil must be well prepared. Fall plowing is often an advantage for the early crop. Smoothing harrows or other tools should be used until a fine and moist seed bed is ready for sowing.

The early varieties are sown as soon in the spring as the ground can be prepared. From six to eight weeks are required for the roots to attain a marketable size. Under favorable conditions the early varieties are ready for market in the North by June 1. Succession plantings of oval and turnip-shaped beets may be made until the middle of August. Long and half-long varieties should be sown in May, as about five months are required for them to reach maturity. While the long types are used to a considerable extent, oval and turnip-shaped varieties are more popular as well as more profitable for the late crop, because they do not need to be sown until after the ground has produced one or two cash crops of other vegetables, and they are also preferred on the market.

The distance between rows will depend mainly upon whether the cultivating is to be done with a hand wheel hoe or a horse cultivator. Twelve inches between the rows is the standard distance for wheel hoe cultivation, although many prefer about 15 inches. When horses are to be used, the spacing varies from 24 to 30 inches. A very successful grower allows only 18 inches between rows and cultivates with a small mule.

The distance between plants in the row should be governed by the variety and the size of beets desired for market. In planting small-topped varieties, to be sold when the roots are $1\frac{1}{2}$ to 2 inches in diameter, 2 or 3 inches apart in the row will be sufficient space. The larger-rooted varieties which are permitted to grow to maturity should be spaced 5 or 6 inches apart.

Some growers prefer to sow thickly, especially in the early spring. This may be done for several purposes, viz., (1) to insure a good stand of plants, (2) to make certain of enough plants, even if the first to germinate should be killed by frost, (3) to provide a surplus for transplanting, (4) to provide a surplus for greens.

Thinning is very generally practiced in beet culture. The best plan is to attend to this work before the plants are injured by crowding. Many growers, however, prefer to wait until the plants are 6 to 8 inches high, when the ones removed are used for greens.

Ten seeds to the foot of furrow, or 1 ounce to 75 or 100 feet of drill (5 to 7 pounds an acre), should insure a perfect stand. One inch of covering is sufficient in moist soils. The seeds may be sown with a drill, although their angular form is not conducive to uniform distribution. Drills with effective agitators are best adapted to this seed. It is important that the soil be firmed well by the wheel of the drill or by other means. This is especially necessary when there is lack of soil moisture. Beet seeds do not germinate as promptly as many other garden seeds, and a few radish seeds are sometimes sown with them to mark the rows so cultivation may begin early.

Beets do not transplant as readily as many other vegetables, but it is common to reset the thinned plants and to sow under glass, and then set the plants in the open when conditions are favorable. If advantage is taken of a moist soil and of cool, cloudy weather, the operation

will be satisfactory. When the work is properly managed there is a gain of possibly two weeks in time of maturity over sowings made in the open. The seed may be sown four or five weeks before the time of planting in the field.

323. Fertilizing.—Beets must grow rapidly to mature early and to develop the highest quality. To accomplish these purposes there must be an ample supply of soluble plant food, especially of nitrogen

Fresh or green stable manures should never be applied a short time before planting, because they encourage a rank growth of top at the sacrifice of root; but rotten cow and horse manure may be used freely. Henderson recommends 75 to 100 tons an acre, while more recent intensive growers use 40 to 50 tons an acre. Some succeed with half this quantity, supplementing with commercial fertilizers. From 1,000 to 2,000 pounds of a high-grade fertilizer can generally be applied at a profit, with an additional top dressing of nitrate of soda. The New Jersey Station found that as much as 800 pounds of nitrate an acre could be profitably used during the season. At each application 100 to 200 pounds may be used by distributing along the rows or sowing broadcast when the leaves are dry. The first and largest application should be made in about three weeks from sowing, making additional dressings as may seem necessary.

324. Cultivation.—Thorough tillage is essential to large yields and high quality. The beet is a surface feeder, so that shallow cultivation should be practiced. The Garrahan hand weeder is a valuable tool for weeding and thinning beets when the discarded plants are not to be reset.

325. Marketing.—Early beets are usually sold on local markets before they have attained full size, because the market accepts a small tender beet, and the grower desires to clear the land as soon as possible for some other

crop. A few days' delay often makes a great difference in market prices, and growers for local markets find that it usually pays to dispose of the small beets as soon as dealers will take them.

The early beets are tied in bunches of three to ten, depending upon size and market requirements (See Figure 64). Washing is usually done after bunching. Bunched beets are shipped from the South in cabbage crates or other convenient, well-ventilated packages.

When prices decline, beets are sold in bulk, the tops being cut about an inch from the crown and the roots packed in baskets, boxes or crates, and barrels.

In sandy soils beets are easily pulled by hand; in heavy land a one-horse plow can be used to advantage in this work.

The late crop may be stored in various ways. Burying is a popular method. Cellars and pits are often used, the roots being covered with moist sand or soil if the air is dry.

Yields and returns are variable. A yield of 300 to 400 bushels an acre is considered good for garden beets, although larger crops have been harvested. Gross receipts range from \$200 to \$600 an acre.

326. Insect enemies.—Although about 200 species of insects feed upon the beet, most of them are unimportant. Flea beetles are the most destructive pests. Bordeaux mixture is the best-known deterrent for these in-

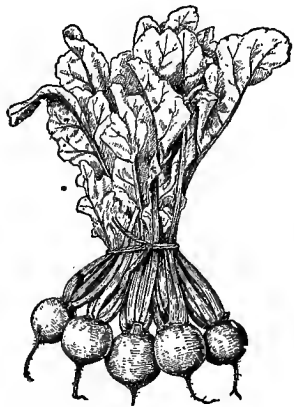

FIG. 64. BEETS BUNCHEA
FOR MARKET

sects. Paris green and arsenate of lead may also be used as poisons for flea beetles.

327. Fungous diseases.—Leaf Spot (*Cercospora beticola*) is a destructive disease to sugar beets, but it seldom does much damage to the garden type. Potato scab (*Oospora scabies*) also attacks the various types of beets, and is often a serious disease of garden varieties. To secure roots free of the scab, seeds must be planted in soil free from the fungus. Rotation is necessary to escape this disease.

BROCCOLI (*Brassica oleracea*, var. *botrytis*)

328. Character.—Botanically, broccoli closely resembles cauliflower, although the heads are usually smaller. In England, where many varieties are grown, there is great variation in the leaves and general habits of the plants. In this country the plants are more hardy to frost than cauliflower and the heads require more time to reach marketable size. The plants are also very sensitive to heat and demand a liberal and constant supply of moisture.

329. Importance.—Broccoli is an important crop in England, being grown on an extensive field scale in some sections. In this country it has never been regarded as a satisfactory vegetable for commercial purposes, because of its inferior quality compared with cauliflower, and also because of the greater difficulty with which it is grown. Henderson claims that the crop fails two seasons out of three, but when successful it is highly profitable. Broccoli thrives best in northern sections.

330. Culture.—It should be produced as a late crop, sowed in the open some time during May and transplanted in the field about six weeks later. The plants may be set 18 inches by 30 inches. The soil should be deep, rich and moist. The leaves are bent, pinned or

tied to blanch the heads, as in the production of cauliflower. White Cape and White French are the leading varieties grown in the United States.

BRUSSELS SPROUTS (*Brassica oleracea*, var. *gemmifera*).

331. Character.—Brussels sprouts is one of the many variations of cabbage. Instead of a single head at the top of the stem, a large bud or miniature head is borne in the axil of each leaf, so that little heads are scattered all along the tall stem, which is crowned with a cluster of loose leaves. (Figure 65.) The solid little heads or "sprouts" as they are known, from 1 to 2 inches in diameter, are cooked and pickled in the same manner as cauliflower. They are regarded as fully as tender and delicious. This vegetable is most appreciated during fall and winter months.

332. Importance. — Brussels sprouts find ready sale on the large city markets, and should be grown much more extensively. Many Americans are not familiar with the excellent quality of this vegetable. The demand for it in the large cities of this country is due mainly to the foreign population.

333. Culture.—The culture is practically the same as for cabbage. Well-bred seed is exceedingly important. Sowings may be made under glass the first of February, transplanting the seedlings to the cold frame in March and to the open ground in April. The plants are slightly less hardy than cabbage. For the late crop, sowings

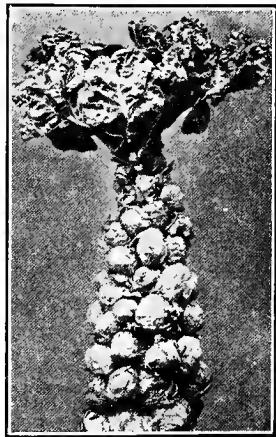

FIG. 65. BRUSSELS SPROUTS

should be made in the open during May, the transplanting occurring six or seven weeks later. Successional sowings may also be made. A deep, rich, moist soil is required for the best results. The plants should be spaced about 18 inches apart in the row, and there should be sufficient space between rows to cultivate with a horse. Nitrate of soda can be used to advantage in addition to stable manure or complete fertilizer.

The miniature heads form on the late plants toward the end of the summer, when the leaves along the stalks are cut off to favor the development of the "sprouts." These improve in quality by frost, and therefore "sprouts" are most in demand during the late fall, although marketed for probably two months before the occurrence of frost. The plants may be lifted and stored during the winter by the methods used for cabbage. The crop is usually marketed in berry baskets, and sometimes in two and four-quart baskets. The leading varieties sold by American seedsmen are Long Island Improved, Burpee Danish Prize and Dreer Select Matchless.

CABBAGE (*Brassica oleracea*, var. *capitata*).

334. History.—In its wild state the cabbage is found on the sea cliffs of western and southern Europe and on the coasts of the English Channel. It has been known from earliest antiquity and was probably in general use previous to the Aryan invasions, 2,000 to 2,500 B. C. Several types were cultivated in the time of Pliny. De Candolle and most authors of English floras admit the plant to be indigenous to Europe. No doubt it was used in the wild state before there were cultivated forms.

335. Botany of the Wild Cabbage.—The wild cabbage plant is herbaceous, usually perennial and sometimes biennial, attaining a height of 2 to 3 feet. The root is tough and woody; the leaves are stalked, lyrate or pin-

natifid, entire, broad, undulated, thick, smooth, covered with a glaucous bloom. The stem bears at the top a spike of yellow, rarely white flowers.

336. Botany of cultivated forms.—There is great variation among cultivated types, particularly of the leaves. The outer leaves may be large or small; few or many; flat or curved; curved inward or curved outward; inclosing the head closely or loosely; long or short; broad or narrow; thick or thin; base well filled out or spatulate; veins few or many, fine or coarse; margin entire or crenate; surface flat or undulate, smooth or crumpled; shape uniform or variable; savoyed little or much, finely or coarsely; color light green, dark green, red or tinged with purple; border sometimes tinged with purple; color uniform or variable; bloom much or little, bright or dull.

The heads may be large or small; flat, flattened, globular or elongated; pointed acutely or obtusely; horizontal section round or angular; soft to very hard. The head leaves may reach or pass beyond the center; drawn or folded tightly or loosely; thick or thin; crisp or tough; well blanched or poorly blanched; sweet or bitter; flavor good or poor. Core large or small; long or short.

337. Classification.—The various methods of classification suggested are unsatisfactory. Market gardeners often speak of varieties as being *early*, *midseason* and *late*. This system of grouping, however, means little, for the time of maturity is largely a matter of how early the crop is started. Jersey Wakefield is generally recognized as an early variety, but some home growers desiring pointed heads and high quality sow the seed in July and August, so that the heads will not mature until October or November, and then the product becomes late cabbage. Succession is usually regarded as a midseason variety, but by starting it early under glass marketable heads may be secured in the North soon after July 1, while later sowings will not make solid cabbage until

freezing weather. A system of grouping suggested by C. L. Allen is the most valuable. ("Cabbage, Cauliflower and Allied Vegetables," p. 54.) The names of certain well-known and usually old varieties are used to indicate the groups, as (1) Wakefield and Winningstadt Group, (2) Flat Dutch or Drumhead Group, (3) Savoy Group, (4) Red Cabbage Group, (5) Danish Ballhead Group, (6) Alpha Group. (7) The Volga group, which is not included in the Allen grouping, is here added.



FIG. 66. A FIELD OF JERSEY WAKEFIELD CABBAGE

338. Wakefield and Winningstadt Group.—JERSEY WAKEFIELD is an old English variety introduced on Long Island about 50 years ago. In 1886, Peter Henderson wrote, "It is universally considered the best early cabbage in cultivation." C. L. Allen, writing probably 15 years later, stated, "It has no superior." Practically all of the old writers praise this variety, and market gardeners today can find nothing better as a first early cabbage. Judging from descriptions and illustrations

in the old books, the type of head as originally grown in England and in this country was more blunt or obtuse at the apex than the average strain now sold by seedsmen. It seems that in the attempt to secure earliness the seed growers have encouraged the conical form, which is now typical of the best strains. Solidity of head, earliness, superior quality and scant outside foliage are the chief merits of this variety. The heads also average larger in size than some other early varieties cultivated less extensively. It is popular among home gardeners, and is unquestionably the leading early variety grown by American market gardeners (Figure 66). Many strains or subvarieties have been introduced under new names. New Century and New Early Gem are examples of so-called superior varieties which have been grown at the Pennsylvania Experiment station.

CHARLESTON WAKEFIELD is supposed to be a strain of the Jersey Wakefield, producing heads a third larger and requiring from three days to a week longer to mature. The heads are not so pointed and the outside leaves are larger. The edible and shipping qualities are good. It is considered the most valuable variety to follow Jersey Wakefield when a pointed cabbage is wanted.

WINNINGSTADT heads are much more pointed than those of Jersey Wakefield, but about the same size, although those grown at the Pennsylvania station are considerably smaller. Because of solidity of heads, tenderness and fine quality, this variety is a general favorite among home gardeners. It lacks shipping qualities, and is seldom planted for commercial purposes, except in a limited way to supply a special trade.

EARLY YORK is of interest historically. It is one of the best-known varieties, is very largely cultivated in England and was a general favorite in this country before the introduction of Jersey Wakefield. The heads differ from the Wakefield type in being oval or reversed-cone

shape, oblong, about twice as long as broad, much smaller than Wakefield and not quite so compact. The variety is now seldom planted in this country.

EXPRESS. This variety has been widely catalogued by seedmen for many years. It was introduced from France and is a selection of Early Etampes, from which a number of early varieties have been developed. The variety somewhat resembles Jersey Wakefield in shape of head, but is smaller and matures several days earlier. It is apparently the same as Race Horse, Wood's Extra Early, and Lightning.

339. Flat Dutch or Drumhead Group.—Of the flat cabbages **EARLY SPRING** is regarded as the earliest and most valuable variety. Some markets prefer this type to the conical, and if earliness is the most important factor, **Early Spring** is the best selection of a flat cabbage that can be made. Growers should bear in mind, however, that this variety is about a week later than Jersey Wakefield and probably a trifle later than Charleston Wakefield. The outer leaves of the head do not become detached readily with rough handling; this is one of the reasons why some market gardeners prefer it to conical sorts. **Early Spring** is widely planted. The heads are solid and large for the time of maturity.

EARLY SUMMER. This variety is a third larger than **Early Spring**, but attains a marketable size three or four days to a week later. It is one of the most valuable midseason varieties. The heads are large and solid and the outside leaves comparatively small in the best strains.

SUCCESSION. A well-known American seedsman says of this variety: "It is the finest cabbage in existence today; whether for medium early, main crop, or later use, it has no equal." It is generally admitted to be a remarkably well-bred cabbage, for large fields often show practically no variation. The heads are larger than **Early Summer**, and the plants are certain headers, even

in moderately fertile soils, provided they have been set at the proper time. Succession is especially valuable for growers of late cabbage whose soils are not rich enough to make a satisfactory crop of late varieties. Other varieties of similar character are Early Flat Dutch, All Head and All Seasons.

SUREHEAD, which was introduced over 30 years ago, is desirable as a late cabbage and possesses some value over Flat Dutch (of which it is a strain) for planting rather late in the season and in soils lacking the necessary fertility for the very late sorts. It often heads satisfactorily when the latest varieties fail. When there is any uncertainty, however, concerning the producing power of the land selected, the only safe course is to fertilize and manure as heavily as possible and plant Succession.

FLAT DUTCH is a standard late variety grown largely in many sections. It requires a long season and a rich soil. The Drumhead and many other varieties cataloged by seedsmen are practically identical.

AUTUMN KING is a superior late variety planted in some sections. It possesses certain characters in leaf and head that make it fairly distinct from the Flat Dutch type.

HOUSER originated near Harrisburg, Pa. It is probably the latest of all cultivated varieties, and should be started at least two weeks in advance of standard late varieties. The heads are much more rounded than the well-known flat cabbages and it might probably be placed in a distinct group. It was introduced in 1897. The originator claims for it large size, solidity of head, fine texture, small heart, excellent flavor and good keeping qualities.

340. Savoy Group.—VARIETIES OF SAVOY CABBAGE. Several varieties of Savoy cabbages are cataloged by American seedsmen, but they vary little in character. The leading variety perhaps is the Drumhead Savoy. These cabbages thrive best during the cool weather of

the fall months, and are seldom grown as an early or intermediate crop. When grown under proper conditions, the flavor is considered more delicate than that of any other cabbage. The demand is limited, however, and large areas should not be planted unless there is assurance of a satisfactory market.

341. The Red Cabbage Group.—RED DRUMHEAD is a standard variety, and probably an important variation of the Large Red Dutch.

MAMMOTH ROCK RED heads larger than the Red Drumhead. Varieties of this group should not be extensively planted without a full knowledge of market conditions, for the demand is very limited compared with green varieties.



FIG. 67. TWO STRAINS OF DANISH BALL HEAD CABBAGE

342. The Alpha Group.—ALPHA is described by Allen. (Allen, C. L., "Cabbage, Cauliflower and Allied Vegetables," p. 67.) The heads are very small, solid and earlier than Jersey Wakefield.

ST. JOHN DAY. This little cabbage, which reaches maturity a few days or a week in advance of Jersey Wakefield, might be placed in a separate group with a few other varieties of similar character. The heads are smaller than Wakefield, round and very hard. The outside leaves are small and permit close planting. For this reason the variety is valuable for companion cropping

with lettuce or other vegetables. It should be planted in very rich soil to secure heads of desirable size.

MINIATURE MARROW is similar to St. John Day. It is planted to a limited extent, but seldom by commercial growers.

343. The Danish Ball Head Group.—THE DANISH BALL HEAD is variously known as Emperor, Holland, Hollander, German Export, Armager and Dutch Winter (Figure 67). It is grown almost exclusively for winter use in Denmark, and was introduced into the United States over 20 years ago. The variety has become exceedingly popular as a winter cabbage because of its superb keeping qualities. It is grown extensively in New York and other northern states, where the cabbage industry has developed to a marked degree. For burying or storage it has no equal and is practically the only variety held for mid and late winter sales. There is considerable varietal variation in the type, but the heads are nearly round, very hard and solid and usually range from 3 to 8 pounds in weight, although larger heads are common. A 4-pound head is a good weight, and if all the plants in a field average 4 pounds the crop is considered excellent. This group is not adapted to warm climates or to certain types of soil. A satisfactory crop is seldom if ever grown on sandy soils. Experiments at the Pennsylvania station indicate that it is not at home on limestone soils. Early sowing is important to secure full yields.

DANISH ROUND HEAD is a strain of the Danish Ball Head which ripens from ten days to two weeks earlier, and is therefore valuable for planting when it is too late for setting the Danish Ball Head.

344. The Volga Group.—VOLGA (Figure 68) is the only variety belonging to the group. It is highly recommended by many seedsmen and some growers are enthusiastic concerning its merits. The heads are fairly

solid, roundish, conical, about the size of Succession. The leaves are crumpled, particularly at the base. It matures with Succession, is true to type, fine in texture and has comparatively few outside leaves. The stems are short and the plants are fairly resistant to disease. Volga is very interesting, but although it has many friends, it is doubtful whether it will ever be as largely planted as many other standard varieties.

345. **Source of seed.**—For years, Long Island has been furnishing the bulk of the seed of all varieties except the

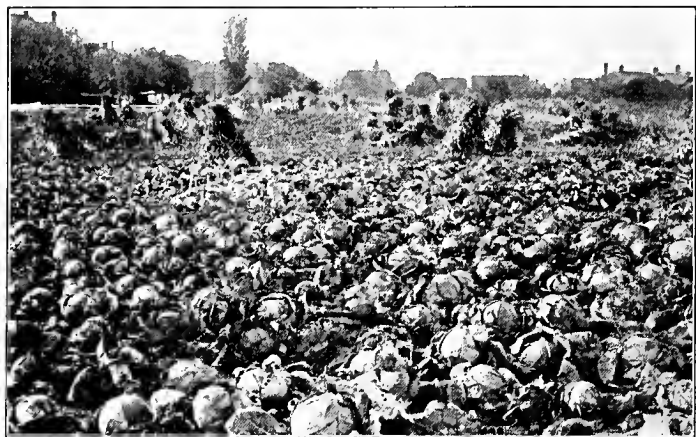

FIG. 68. VOLGA CABBAGE ON LIMESTONE SOIL

Danish Ball Head. Seed of this variety is almost entirely imported from Holland and Denmark. Seedsmen and growers alike have been led to believe that Long Island grown seed has merit over stock from other parts of the country. Is there any foundation for taking such a position? It is true that the natural conditions of Long Island are favorable to the cabbage, and that several men on the island have been successful in growing cab-

bage seed on a very large scale. On the other hand, just as good seed has been grown in the Puget Sound district, in Pennsylvania, New Jersey, Virginia, Michigan and no doubt in other states. Soil and climatic conditions are important factors, but the skill, thoroughness and conscientiousness of the grower count for more than favorable natural conditions. It is somewhat troublesome for a gardener to grow his own seed, but the plan is practical and is followed by a few careful gardeners. Good seed is largely a matter of intelligent and thorough roguing.

346. Seed growing.—To make proper selection of plants for seed purposes the heads should be nearly mature. A common practice among large growers is to sow so late in the season that only a small percentage of the heads will be well developed when the roguing is done. Such plants winter with a smaller percentage of loss than when more mature, but the selection is likely to prove unsatisfactory. The gardener should know the time requirements of the variety from which seed is to be grown and try to have the heads nearly mature just previous to burying. On Long Island, most late varieties are sown about June 15, while those of the Wakefield type are not started until August. These dates for sowing would be too late for most northern states. The plants should not be grown in excessively rich soils, for very large heads do not winter well.

The roguing should be done as late as possible, discarding all heads not typical of the variety. Thorough winter protection must be given to both roots and tops. The plants may be buried where they were grown and the covering removed the following spring. In this way a crop of seed may be produced without two transplantings; but the more approved plan is to lift the plants and bury before there is danger of hard freezing weather. Various methods are used in providing winter protec-

tion. One of the best is to place three plants side by side in long trenches, made by plowing a furrow each way. The plants may be placed erect with the roots down, but better protection will be given by placing them at an angle of about 45 degrees. Two or 3 inches of soil is sufficient covering at first, although no injury will be done by 6 inches of soil if the weather is cool. After the ground is frozen, several inches of manure should be added, and in the coldest regions a foot might be used to advantage.

As soon as the ground can be worked in the spring the plants are removed from the trenches and set in rows $3\frac{1}{2}$ feet apart. Rather deep furrows are required to give the plants proper support, and ridging or staking must be resorted to later in the season when the seed stalks are developing. To allow the seed shoots to push through the heads with ease the tops are cut crosswise at the time of planting.

The seed stalks are cut about July 1, or when the pods have turned yellow, and placed in rows to dry. From two to four days are generally required for drying. When dry the stalks are loaded on a wagon, which should have a large cloth extending around and reaching over the sides of the bed, to prevent loss of seed.

A tight floor is necessary in threshing, which may be done any time after hauling from the field. The seed should be milled and thoroughly dried before storing. It usually takes from 20 to 25 plants to make a pound of seed, although frequently two ounces are obtained from a plant.

347. Climate.—It is well known that cabbage thrives best in a cool, moist climate. For this reason its culture is largely confined to northern districts. When grown in the South, outside of the mountain areas, advantage is taken of the cool months of late winter or spring. The Danish Ball Head is rarely grown south of Pennsylvania, and at low altitudes in this state this variety is of doubtful value.

348. Soils.—Successful crops of cabbage are grown on a great variety of soil types, the enterprise being developed to large proportions on soils ranging from light sand to heavy clays. It is largely a question of constant moisture (although good drainage is essential) and of abundant food. Excellent crops of early and late cabbage have been grown on sandy loams, often along mountain streams, where there is a large deposit of vegetable matter and a regular supply of moisture. Perhaps the largest crops of late cabbage have been grown on clay loams, well enriched by manure. The mountain glades of the Appalachian system seem to be well adapted to this crop. Danish Ball Head, which is the most limited in soil and climatic adaptation of all the varieties, succeeds well on the DeKalb series of soils in Pennsylvania. The reclaimed swampy glades in the mountains of West Virginia have produced large crops without manure or fertilizer, although these materials, with the addition of lime, increase the yields. A mellow soil which does not bake hard and which is well supplied with humus will generally produce satisfactory crops.

349. Growing early plants.—There are at least five distinct methods of growing early cabbage plants: (1) From Baltimore, southward, the general practice is to sow in the open, usually in October, and when six to eight weeks old the plants are set in the field on the sides of ridges. They may also be wintered in the beds, with protection if necessary, and shifted to the field early in the spring. Fall planting, however, is more satisfactory because it produces an earlier crop. (2) The common practice years ago in the North was to sow in the open early in September and transplant into cold frames the latter part of October, the plants being protected with sash during the winter. The results were highly satisfactory, and the plan is still used by some gardeners.

who claim that plants grown in this manner produce earlier cabbage than spring-grown plants. (3) An extensive grower of plants in Pennsylvania sows in very cool greenhouses early in September, transplants and holds in flats during the winter months. With a very low temperature the plants make a slow, stocky growth and with some hardening before transplanting in the field the best results may be expected. The most serious objection to the plan is the expense of operating houses for so long a period. (4) If earliness is not an important factor, the sowing may be made in hotbeds or cold frames about March 1, and the seedlings transplanted directly to the field. When this plan is adopted the seed rows should be not less than $3\frac{1}{2}$ inches apart and the plants thinned if necessary. (5) The plan which is now almost universally practiced in the North is to sow in hotbeds or greenhouses in January or February. If several hundred thousand plants are to be grown it is desirable to begin sowing about January 25 and to sow at intervals of a day or two until February 5. This will make it possible to transplant without any of the seedlings becoming spindly or drawn. For details of this method see Chapter XVI.

350. Growing late plants.—Glass is not required in growing late plants. The common practice is to sow in the open, and transplant directly to field or garden. Many failures are due to the use of inferior plants. It is important that every possible effort be made to secure strong, stocky plants, ready for the field when all conditions are favorable for setting. It is an advantage to have the seed bed near the field to be cropped, so that the plants can be shifted without much loss of time or drying of the roots.

In selecting and preparing the seed bed, excessive fertility should be avoided, for very rich soils produce weak, succulent plants likely to succumb under field conditions.

The seed bed should be moderately fertile, fine, clear of stones or rubbish which would interfere with drilling, free from germs of diseases infecting the cabbage, and well supplied with moisture, particularly at the time of sowing. In order to have a full supply of moisture to insure germination, the soil should be plowed early in the spring and harrowed often enough to conserve the moisture. A special precaution may be taken by mulching the prepared soil with coarse litter from the stables.

The time of sowing depends upon locality, exposure, variety and purpose of the crop to be grown. For most localities in the North, sowings may be made any time during May; some growers prefer June 1 or later. The latest maturing varieties, as Houser and Danish Ball Head, should seldom be started later than May 15, and earlier sowing is an advantage where the growing season is short, as in the mountain regions of Pennsylvania. Early sowing is important from the standpoint of yield, while late sowing, resulting in retarded maturity, is favorable to a long period of storage.

Extensive growers use drills in sowing, making rows about 1 foot apart, thus providing ample space for tillage with hand wheel hoes. Too heavy sowings should be avoided, as thinning will then be necessary if the seed is good, in order to secure stocky plants. Eight to ten seeds an inch of drill should make a satisfactory stand. If the soil is fine and moist, $\frac{1}{2}$ to $\frac{3}{4}$ inch of covering will insure germination. Some successful growers prefer broadcasting rather thinly, to avoid crowding of plants. When this is done the bed should be in the finest condition and the seeds raked in lightly with a garden rake.

351. Sowing where the plants are to mature.—Some growers prefer sowing where the plants are to mature. The two main advantages are that the expense of transplanting is avoided and there is no checking of growth,

which is incidental to this operation. On the other hand, several disadvantages are to be considered. It is more expensive to combat insects when the plants are scattered than when confined to a small area. The expense of tillage is increased, and the cost of thinning must be taken into account. If the soil is heavy, it will become compact before the roots have made any considerable growth. This may result in reduced yields. In light, friable loams the system may be used with entire success, especially when the cost of labor is high and where transplanting machines are not available. Sowing is done most economically in this system by machines which drop and cover about half a dozen seeds at the required distances. Half a pound of seed is ample for an acre. The rows should be checked to facilitate thorough tillage. Sowing may be a week later than when transplanting is resorted to. When the plants are three or four weeks old they should be thinned, leaving the strongest at each place.

352. Soil preparation.—For early cabbage, fall plowing is generally desirable; heavy sods especially must be plowed down in the fall for best results. The vegetable matter will then be partly decayed by spring and of more immediate value to the crop; the soil will be filled with moisture, which should be conserved by harrowing as soon as the ground is dry enough. This tillage operation should be repeated as often as may be necessary to put the land in proper condition for planting and to retain plenty of moisture to make transplanting successful.

The most important factor in preparing soil for late cabbage is the question of moisture. Many failures are due to the late plowing of sods, followed by dry weather, which sometimes continues long after the proper time for transplanting. The only safe practice is to plow rather early in the spring, working down the land, as explained for the early crop.

353. **Composition.**—The Maryland Station (Maryland Station Bulletin 133 (1909), p. 197) has made a thorough study of the chemical composition of the cabbage. The following tables are adapted from the report upon this subject:

FOOD CONSTITUENTS IN HEADS AND REFUSE CABBAGE

	Heads per cent	Refuse matter per cent
Water	98.50	91.02
Ash	0.21	3.58
Protein	0.41	1.42
Crude Fiber.....	0.38	1.32
Nitrogen-free extract.....	0.46	2.41
Fat.....	0.04	0.25

It will be seen from this table that cabbage is a very watery food, but that the amount of protein in the dry matter is relatively large.

FERTILIZING MATERIAL FOUND IN THE DIFFERENT PARTS OF CABBAGE PLANTS

(Per cent in Fresh Materials)

	Heads per cent	Refuse leaves per cent	Root per cent
Phosphoric acid	0.023	0.080	0.111
Potash	0.087	0.402	0.762
Nitrogen	0.065	0.227	0.352
Lime.....	0.019	0.441	0.107

354. **Manure and fertilizer requirements.**—Figuring on the basis of 8,000 mature heads to the acre, each head weighing $3\frac{1}{2}$ pounds, an acre of cabbage would require during the season the following amounts of plant food;

POUNDS OF FERTILIZER FOUND IN CABBAGE FROM ONE ACRE

	Heads pounds	Refuse pounds	Roots pounds	Total pounds
Phosphoric acid.....	6.4	14.4	2.4	23.2
Potash.....	24.4	72.4	17.2	114.0
Nitrogen.....	18.2	40.8	8.0	67.0

To furnish all of the plant food for this yield of 8,000 heads, or 14 tons an acre, would require the equivalent of 165 pounds of phosphate rock of 14 per cent grade, 228 pounds of muriate of potash of 50 per cent purity and 447 pounds of nitrate of soda of 15 per cent purity. The total cost of these materials an acre would not exceed the amount frequently applied, but the proportions—3 per cent phosphoric acid, 14 per cent potash and 8 per cent nitrogen—would be unusual. The analysis shows, however, that potash is very important in the production of this crop, and that nitrogen should be supplied in larger amounts than is usual. It is not necessary to use potash so freely in clay soils, but it is highly probable that 10 per cent of this element is not too much for most other soils. Although the phosphoric acid requirements are relatively small, the grower should not lose sight of the fact that most soils are very deficient in this element, and there are doubtless localities where it should be used more freely than potash. The most successful growers seldom use less than 4 per cent of nitrogen, and the analyses indicate that this is the minimum amount that should be used, unless there has been a large application of manure. The basic fertilizer, 4-8-10, should meet the requirements of most soils, especially if nitrate of soda is used later as a top dressing.

Fifteen hundred to 2,000 pounds of fertilizer are generally used for the early crop, and many growers of late cabbage do not apply less than these amounts. It is

especially desirable to use large amounts of highly nitrogenous fertilizers for the early crop, to hasten maturity. One application of 150 pounds of nitrate of soda about four weeks after planting, and the same amount when head formation begins, generally increases the yield. It is not necessary to distribute this fertilizer around the plants or along the rows, but it may be applied broadcast by hand as clover seed is sown. The results are often marked, especially when used on moderately fertile soils before rain and after a long period of drouth.

It is universally conceded that stable manures are the best fertilizers for cabbage. They may be used with the greatest freedom, profits generally being largest from the most liberal applications. Henderson recommends not less than 75 tons of manure an acre. Comparatively few growers, however, can use it so lavishly for this crop; 10 to 25 tons an acre is the usual application. Of course, it should be spread before plowing, while fine manure can be disked in after plowing with better results.

355. Planting distances.—The proper distance between plants depends upon the variety, purpose of the crop, fertility of the soil, and methods of cultivating, spraying and harvesting. Early varieties, as Jersey Wakefield, may be planted 14 x 26 inches or even closer; Charleston Wakefield, 16 x 28; Early Summer and Succession, 18 x 28; Danish Ball Head, 18 x 30; Flat Dutch and other late flat-headed varieties, 24 x 36 inches. Close planting is conducive to small heads, which are often preferred by consumers. If sold by the head, and if the heads are large enough to meet market requirements, a maximum number to the acre will of course secure largest returns. The richer the soil the closer the plants may be set and still get heads of marketable size. Close planting, however, prohibits cultivation late in the season, which is very important in dry weather. It may also prevent the use

of power sprayers, and of carts or wagons when harvesting the crop. Yields by weight are larger when distances are medium rather than close. The most approved plan is to plant rather close in the row and allow a liberal space between rows. Some of the most successful growers prefer planting in check rows because of advantages in cultivating, and because less hoeing is required than in the usual method.

356. Transplanting in the field.—A moist soil and damp, cloudy weather are most favorable to transplanting in the field. The plants should not be checked more than necessary and an effort should be made to retain as much soil as possible on the roots. If grown in flats, each plant may be removed with a portion of soil and manure attached (Figure 38). Flat-grown plants if carefully removed from the boxes may be set in the driest weather without watering, either at the time of transplanting or afterward. It is urgent, however, that no time be lost in getting the plants into the field when the time for planting arrives. This time is variable through the North, but April 15 is not too early for most sections. If the plants have been well hardened, they will stand severe freezing in the field, and a drop of 10 degrees below freezing may do no harm.

In the South the plants are usually set in the fall on the south or the east side of ridges. Deep planting is important for fall setting, to prevent splitting or bursting of the stems.

Large areas are generally planted by machines. The transplanter is a valuable implement, because its work is better than that of many laborers. By steady driving the rows may be made very straight and the plants set even more firmly than by hand. The furrow is closed in a few moments after it is opened, so there is no time for the soil to dry out and the roots are brought into intimate relation with the soil particles. Water may be used

if necessary. A team, a driver and two droppers can plant three to four acres in a day of 10 hours.

The plants may also be set by the use of dibbers and trowels. Some growers open furrows with a narrow shovel plow. When the furrow method is used, the plants should be set promptly, before the fresh soil becomes dry.

357. Intercropping.—When cabbage is grown on a large scale, intercropping is seldom practiced. Market gardeners, however, with a limited land area often find companion cropping very desirable. (See Chapter XXIII.)

358. Cultivation.—Tillage should begin as soon as the plants are sufficiently erect after setting and be repeated at frequent intervals. It should be continued as late as possible, crowding between the rows, even if some leaves are broken from the plants. There will be few broken, however, if the cultivating is done between 9.00 A. M. and 4.00 P. M., when the leaves are limp and bend readily.

359. Harvesting.—When the demand is great and prices high, it requires patience to wait until the early crop is fully ready to market. The fact is that a large percentage of early cabbage is cut before the heads become sufficiently solid to hold up well. The result is the market is crowded with inferior cabbage, which causes dissatisfaction among dealers as well as among consumers. The bulk of the southern crop is packed and sold in crates or barrels, with insufficient regard to the weights of the filled packages. A nearly matured head will occupy about as much space as it would a few days later when hard and solid, but would weigh much less. Sales are always restricted when the heads are soft and loose. It is doubtful whether cabbage should ever be cut until solid, except late in the fall, when there is danger of severe weather that would entail loss. If sold by

weight it is seldom that the increase in weight will not make up for the decline in price.

A large butcher knife is the most satisfactory tool for cutting cabbage. A whetstone should be kept in the field and used often enough to maintain a sharp edge on the knife. In cutting, place one hand on the head, first determining, if necessary, its solidity, then with the other hand sever it while it is drawn to one side, retaining as few outer leaves as possible. Whether sold by weight or in packages the outer leaves should be removed. When the crop is to be stored in pits or houses, it is customary to retain two or three outer leaves for protection. If the cabbage is to be buried, a sharp hatchet is the most serviceable tool with which to cut the stems.

Two or three rows of extra early varieties are often planted at convenient intervals to provide roadways for gathering the crop. Intensive gardeners often use wheelbarrows with large boxes, while growers cultivating large fields generally plant so that a wagon will straddle two rows. There is no difficulty in collecting the late crop, for it is usually cut clean. Cabbage should always be handled with care, to prevent bruising. An excellent plan is to keep a man on the wagon to catch and place the heads as fast as two or three men can cut and trim them. If cut during the day when the wagons are absent, three or four rows may be placed together for convenience in loading.

360. Marketing.—As previously stated, southern cabbage is nearly always sold by the crate or the barrel, and these methods are common among growers in the North. The crate is the best package because of its perfect-ventilation and compactness when loaded on wagons or cars. Cabbage crates vary in shape and size. The following are inside measurements of those used in various parts of the country: The Mobile crate is 16 x 16 x 26½ inches; Charleston or South Carolina crate is 11 x 19 x

38½; Florida, 12 x 20 x 36; Lexington, 15 x 15 x 33½; Baltimore, 10 x 18 x 35; Norfolk, 10 x 20 x 37; and Chicago, 17 x 17 x 32. Second-hand truck barrels are used extensively in the North, and sugar barrels are excellent for handling winter cabbage when sold by weight. Summer shipments require free ventilation, which may be provided by cutting about four large vents with an ax in the sides of each barrel after packing. Winter shipments may be protected by lining the inside of the barrels with paper. Firm and close packing should be the aim of the shipper, whether the cabbage is sold by the package or by weight. To prevent rotting, it is important that the cabbage be dry when placed in the package. Large quantities should be shipped in refrigerator cars in warm weather, in slat cars when weather is cool, and in the warmest box cars in cold weather. An inverted V-shaped ventilator is often made of rough boards and placed lengthwise in the center of the cars when bulk shipments are made late in the summer or early in the fall.

With many local markets and in some of the large cities the crop is sold by the head or the hundred heads. When this is done the cabbage is loaded in bulk on the wagons and the heads counted when sales are made. It is a convenient method for many growers, and may be advantageous to grower or dealer, but seldom to both. The most satisfactory way is to sell by weight, and this method if generally adopted would materially raise the quality of cabbage produced in various parts of the country.

361. Storing.—A large percentage of the late crop is stored and sold during winter and early spring. Success in storing depends largely upon the variety. The flat or domestic cabbages, as Flat Dutch, keep only fairly well under the best conditions. We must look to the Danish Ball Head class to find the long keepers. It is

nearly always desirable to dispose of the flat cabbages in the fall, although some growers succeed well in holding them for midwinter sales.

Whatever method is employed, the aim must be to keep the cabbage in a perfectly sound, fresh, crisp condition. One method may succeed admirably in preserving soundness, but may fail to keep the heads crisp and juicy, while another method may be successful in main-

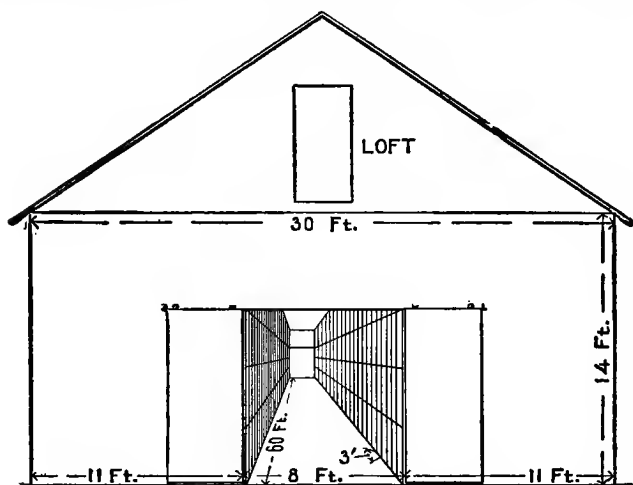

FIG. 69. NEW YORK CABBAGE HOUSE

taining a fresh, juicy condition, but fail to prevent rot. The ideal method must succeed in both of these respects. The following conditions are essential to satisfactory storage:

1. The cabbage must be kept cool. Low temperatures are unfavorable to disease germs, which cause decay.
2. The air must be kept moist. A dry atmosphere causes the cabbage to wilt, to dry out and to lose its freshness and crispness.

3. Hard freezing must be prevented. Slight freezing does no harm, but a drop of 10 or 12 degrees below freezing may cause a total loss of the crop.

4. Although a certain amount of moisture is essential an excessive amount must be avoided, for it causes decay, especially if the temperature is high or the ventilation poor.

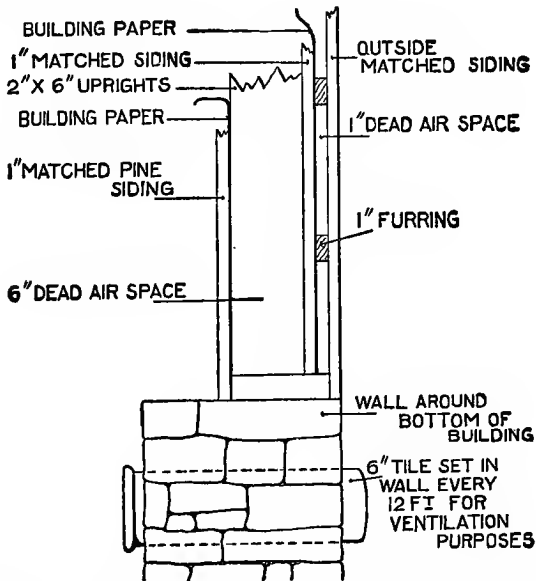

FIG. 70. NEW YORK CABBAGE HOUSE, SHOWING WALL CONSTRUCTION

Large storage houses are used in the great cabbage-producing districts. The following description of a house near Rochester is typical of the houses used in New York and in Erie County, Pa.

This house (Figures 69, 70 and 71) was built in 1900 at a total cost of \$2,000, which includes all materials,

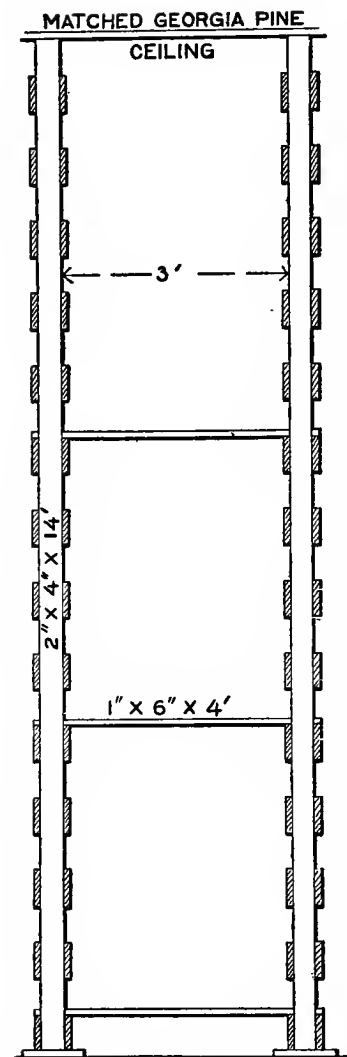

FIG. 71. NEW YORK CABBAGE HOUSE
SHOWING BIN CONSTRUCTION

hauling, masonry and carpentry. With the price of materials 10 years later, the cost would be nearly \$3,000. The dimensions of the house are 30 x 60 feet. It has 32 bins, 3 x 11 feet and 14 feet high, each bin holding five tons of cabbage. The driveway is 8 feet wide and is frequently filled, giving an additional capacity of 40 tons, or 200 tons as the maximum capacity.

The ceiling (which is also the floor of the loft) is of matched Georgia pine, and has eight trap doors over the bins for ventilation, which is very essential during the first few days of storage. The floor of the lowest bin is 6 inches above the ground, to allow free circulation of air under the cabbage. The floors are made by placing 2 x 4 cross-pieces between the cleats on the sides of the bins and then laying 12-foot boards lengthwise. These boards should be 6 inches wide and laid with an inch or more space between them to provide for air circulation. Tiles placed in the wall at

the surface of the ground and at intervals of 12 feet provide ventilation under the bins. In severe weather they may be closed by stuffing with old sacks. The bins are made of 2 x 4 uprights, with 4-inch boards as siding, the boards being placed 4 inches apart, and the uprights making an air space of 4 inches between bins. When the driveway is used for storage it is necessary to construct similar bins in the passage, as this is filled from the wagons backed in from each door toward the center of the building. The loft may be used for storing barrels and crates. (See Figures 69, 70 and 71.)

Some farmers store a few hundred heads of cabbage in the house cellar. If this can be kept cool, moist and properly ventilated, the results are generally satisfactory. Most cellars, however, are not favorable to storing vegetables, and cabbage is an undesirable crop to have in the cellar of the residence.

Outside cellars are satisfactory if properly constructed. They may be used for other vegetables. The walls should be stone, brick or concrete and the roof should be provided with air chambers, to make it frost proof. The cellar may be of any desired dimensions, 14 x 18 feet being the most common, and dug to any convenient depth and the walls built up even or slightly above the ground level. Rafters and boards may be used in the roof construction, or boards alone if provision is made for a ridge pole and purlins and supports between ridge pole and side walls. The roof should be covered with soil, sods, manure or other material, to furnish additional protection from cold. Small cupolas or ventilating shafts should be built through the center of the pit at intervals of about 15 feet. The gable ends should contain windows for light and ventilation.

Pits of both permanent and temporary character are in common use. They vary in width from 8 to 18 feet. The wider pits are more economical in construction for

the amount of storage space provided, and are more convenient in use. These pits are dug about 2 feet deep, and the sides made of brick, stone, concrete or wood. A well-drained location should be selected for the pits near the farm buildings, where it will be convenient to care for them and to prepare the crop for market. The roof construction may be of boards or concrete, and provision must be made for ventilation, as explained in the previous paragraph. Strawy horse manure is excellent to cover the roof. Inexpensive pits should be in more general use among growers who do not produce enough winter cabbage to justify the erection of storage houses.

Various methods of burying or partial burying are in use. Where the winters are mild, little protection is necessary. Near Washington, D. C., the plants are pulled and stood upright in long, shallow trenches 5 or 6 feet wide; a furrow is thrown up on both sides and marsh hay spread over the tops of the heads, the amount of hay being increased when the weather becomes severe. With this plan the heads become solid and may be easily removed at any time during the winter. Farther north the plan is modified by making narrow trenches and providing better protection by using more soil, hay or manure. A favorite plan in southern Maryland is to turn the heads where they grow toward the north, and to cover the stems and the lower part of the heads with earth. If preferred, the heads may be gathered together and protected in this way.

On Long Island a very common method is to draw a furrow 6 to 8 inches deep, pull and place the plants in the trench with heads down. A furrow thrown from each side completes the work of burying. This makes a covering of about 1 foot of soil, which is ample for that locality.

The following plan of burying cabbage has been successful and may be used in all parts of the North: The crop is cut with sharp hatchets, stubs 4 or 5 inches long

being left for convenience in handling. If preferred, the crop may be gathered and hauled to a convenient, well-drained field near the barn or other building to be used in preparing the crop for market. The heads are placed on top of the ground, in long rows, three heads in width, side by side, the rows running up and down the slope of the land, to provide drainage. The usual custom is to invert the heads, but better protection is afforded by placing them on their sides, with the outer leaves beneath. A layer of cabbage one or two heads in width may be placed on top, but this increases the labor of burying. The windrows should be far enough apart to drive between them with a wagon.

After the crop has been placed in this manner a two-horse plow is used in drawing two furrows on each side of the windrows, as much soil as possible being thrown over the cabbage. The burying is finished with shovels, when care is taken to get 5 to 6 inches of soil over the cabbage. If buried about the middle of November, the soil will afford sufficient protection for at least a month, when 3 or 4 inches of manure should be thrown over the ridges. Additional manure may be used in the coldest localities. If more convenient, the manure may be applied immediately after burying, but there is no necessity for making such an early application. If the cabbage is sound, there should be no loss from this method. If handled on a large scale, the actual cost of burying, aside from the use of manure, which should not be reckoned, will not exceed 60 cents a thousand heads.

The most serious objection to burying is the unpleasantness of taking out the cabbage in very cold weather. Large quantities, however, may be removed on the mildest days and stored in the barn or the cellar to meet the daily demand.

362. Yields and returns.—Yields vary from a few tons to 25 tons an acre; even larger yields have been secured

from small areas of high fertility. With approved methods it should not be less than 15 tons an acre. A Colorado grower in 1908 averaged 25 tons an acre on a 12-acre field and the net returns were \$340 an acre. This, however, is much beyond the returns of most growers. The eleventh census report states that the net profit an acre of the 77,000 acres grown in the United States is \$118. The large proportion of early cabbage grown in the South is doubtless responsible to a great extent for this good showing. It is generally conceded that early cabbage is more profitable than late. Northern growers often clear \$200 an acre. Prices for the late crop are extremely variable. When sold out of the field the price ranges from \$2 to \$15, and out of storage from \$8 to \$60; when sold by the head, the price runs from \$2 to \$6 a hundred, and 60 cents to \$3 a crate or a barrel.

CHICAGO WHOLESALE CABBAGE PRICES*

	Nov.	Dec.	Jan.	Feb.	Mar.
'06-'07	\$ 4-5	\$ —	\$ —	\$ —	\$ —
'05-'06	15-20	18-22	19-24	21-24	30-36
'04-'05	4-8	4-11	8-11	7-10	12-15
'03-'04	7-9	20-25	35-38	50-55	55-60
'02-'03	4-6	6-7	10-12	6-9	7-9
'01-'02	10-12	9-11	10-14	14-16	17-20
'00-'01	10-11	11-14	8-14	16-18	19-20
'99-'00	12-14	14-17	25-26	22-25	28-30
'98-'99	6-8	8-10	16-18	28-30	35-40

The usual estimates for the cost of producing and marketing an acre of cabbage are too low; \$125 an acre for early cabbage and at least one-third this amount for late are not too high. Large net returns are seldom secured without a liberal outlay. With favorable markets or good shipping facilities it is unquestionably one of our most profitable vegetables.

363. The cabbage maggot (*Pegomya brassicae*) was introduced from Europe early in the nineteenth century. It feeds upon various cruciferous plants, but is espe-

*American Agriculturist.

cially troublesome to cabbage and cauliflower. Chittenden ("Insects Injurious to Vegetables," p. 132) claims that the insect has been on the increase since 1902.

The adult resembles the common house fly, but is considerably smaller. It begins laying eggs early in spring, depositing them on or near the stems of the young plants. Slingerland observed that the fly makes its first appearance on Long Island the latter part of April, and that larvæ were first seen in early May. From 4 to 10 days are required for hatching. The larva or maggot is footless, shining white, sometimes tinged with yellow and when full grown is 0.32 of an inch long. It prefers feeding on the young tender rootlets, but also erodes and girdles the stem of the plant, often boring into the lower part of the root. It pupates within its own hardened skin in soil about infested plants. The time required for pupation is from 15 days to 3½ months. A second brood emerges about the middle of June and changes to puparia in July. The life history from this time is unknown, but it is thought that the insects pass the winter as maggot, pupa and fly.

Numerous preventives are recommended, but one of the best is to place card disks about the plants before egg laying begins. (Cornell Station Bulletin 78, pp. 481-574). Although effective, the making and placing of these cards is tedious and the plan is not generally popular with extensive growers. Carbolic acid emulsion (133) is the most practical means of controlling the pest. It should be diluted about 30 times and applied by spraying on the stems of the plants before egg-laying begins, and repeated if necessary. Experiments made at Geneva, N. Y. (New York Station Bulletin 301), show that growing the plants in frames covered with cheesecloth is a satisfactory method of protection before transplanting.

364. The cabbage aphid (*Aphis brassicae*), also known

as the cabbage louse, has been known in America for over a century, and has become disseminated throughout the country. Its destructiveness varies greatly from year to year, depending upon seasonal conditions and the prevalence of natural enemies. In many states it was especially troublesome and caused heavy losses in 1908 and 1909. Both seasons were drier than usual, and it seemed that neither insect nor fungous foes had much effect in checking the ravages of the aphid. Protracted drouth unquestionably favors the multiplication of this pest, while low temperatures with heavy rainfalls are the most unfavorable conditions.

This insect usually appears in the North the latter part of May or early in June, and feeds upon both upper and under sides of the leaves, which they cause to curl. The pest multiplies with marvelous rapidity, producing from a dozen to a score of broods in a season. (Bulletin 2, Virginia Truck Experiment Station, Norfolk, Va.) The bodies of the mature forms are green, but are covered with a grayish, powdery coating, which at a distance gives the appearance of mildew. The young are ready to reproduce in five or six days.

The eggs, which pass the winter attached to the stems and the refuse leaves, give rise to the first broods next spring. This suggests the most effective means of prevention: all refuse in infested fields should be destroyed in the fall. It is also important to destroy remnants of infested plants from which the summer crop has been harvested.

Spraying with kerosene emulsion, diluted to 15 parts, is a satisfactory means of controlling the insect on growing plants. The first application should be made before the infestation becomes general. A knapsack sprayer, with the proper nozzle and extension attachments may be used to advantage in spraying isolated plants and small plantations. It is important that the material be applied to the underside of the leaves as well as to the

upper surfaces. To accomplish this thoroughly seems almost impossible with a power machine.

365. The imported cabbage worm (*Pontia rapae*) is generally recognized to be the most important insect enemy of cabbage and several closely related crops. The pest was first seen in North America in 1860 at Quebec, five years later in Maine. Now it is distributed throughout the United States. The butterfly is familiar to all garden makers. It is white, with a wing expanse of nearly 2 inches. There are two conspicuous black spots on each fore-wing of the female and only one on the fore-wings of the male. The full grown larva is over an inch long. It is nearly green and finely dotted with small black spots. A faint yellow stripe marks the middle of the back with a row of yellow spots on each side in line with the spiracles. The pale yellowish eggs are deposited singly, and usually on the underside of the leaves.

The butterflies appear early in spring, and in a few days begin laying eggs, which hatch in four to eight days, the larvæ attaining full maturity in from ten days to two weeks. The chrysalis stage during the summer months lasts from one to two weeks. The insect also passes the winter in the chrysalis form. There are three broods in the North in one season.

Several natural enemies of this pest assist the grower in controlling it, but it is often necessary to use insecticides. All points considered, arsenate of lead is probably the most effective poison in destroying cabbage worms. Other remedies are hot water, kerosene emulsion, and pyrethrum.

366. Other insect enemies.—The southern cabbage butterfly (*Pontia protodice*), the cross-striped cabbage worm (*Evergestis rimosalis*), the common cabbage looper (*Autographa brassicae*), the imported cabbage web-worm, the harlequin cabbage bug (*Murgantia histrionica*), cut-worms, flea-beetles and leaf-beetles.

367. **Club root** (*Plasmodiophora brassicae*), also known as "club foot" and "clump foot," is unquestionably the most serious disease of crucifers. (Figure 72.) If uncontrolled it will soon spread through a community and render the profitable cultivation of cabbage and allied plants impossible for several years, a situation that has developed in a few sections of the United States. The malady has been known in Europe for more than a century and in this country for many years.



FIG. 72. CLUB ROOT OF
CABBAGE

The disease is most destructive to cabbage and turnip, but also affects cauliflower, brussels sprouts, kale, radish, kohlrabi, rutabaga, white mustard and many cruciferous weeds, shepherd's purse and hedge mustard being especially subject to infection.

The character of the disease and its relation to "clubbing" were determined by the Russian botanist, Woronin, who found that the micro-organism which causes the distorted enlargement of roots was a slime mold and not a bacterium nor a fungus. There is distinct "club-

bing" in many cases, while in others irregular knots are formed. When the disease has advanced for several weeks, the deformed roots are incapable of supplying the plants with sufficient moisture and nourishment. The plants then become dwarfed and lighter in color. Affected plants wilt quickly in warm, sunny weather, especially if preceded by humid growing weather. The disease is less serious with the early than with the late crop, for with the best conditions for growth at this

time many of the infected plants will mature, although the heads are usually small. Plants set in the field in June or July seldom mature marketable heads if attacked by club root.

The spores of this disease are inclosed by protective coverings that give them great vitality. It is not uncommon for the disease to recur in soils where crucifers have not been grown for 10 or 15 years. With annual tillage the spores soon become mixed with the soil and the malady may spread over the field or the entire farm or the community, and as no treatment of the plants has been found effective, the grower must resort to preventive measures. The following paragraphs relate to ways of infestation or dissemination and methods of prevention:

1. As young seedlings are most susceptible to attack, great care should be exercised in selecting soil for the seed bed. Affected plants should always be discarded.

2. Rotation should be practiced, in which cruciferous plants should not be planted more frequently than every four years.

3. The disease thrives best in acid soils. In Belgium the calcareous soils were the last to become infested, and lime is the best-known means of soil treatment, although often unsatisfactory. The New Jersey Station reports that 75 bushels of stone lime an acre gave as good results as larger applications. The lime should be applied in the fall or at least several months in advance of planting.

4. Roots, stems and leaves from diseased fields should be burned. If fed to stock or used for composting such refuse will be a certain means of disseminating the malady.

5. In the purchase of all kinds of stable manures, the grower should make certain that the stock has not been fed plants which might cause infestation.

6. The disease is often found in small patches. The safest policy in such a case is to inclose the plat with a fence to prevent the spores being carried to other parts of the farm by means of implements, wagons; and the feet of horses and workmen.

7. Wild mustard, shepherd's purse and other cruciferous weeds should not be allowed to grow and serve as host plants in fields which will be used for cabbage or allied crops.

8. The grower should always guard against the purchasing of plants that have been produced in soils infested with club root, for this would be a certain means of disseminating the disease.

368. Black rot (*Pseudomonas campestris*).—This bacterial rot is very generally disseminated, frequently spreading over large areas in cabbage-growing districts, and causing heavy losses. The disease also affects cauliflower, kohlrabi, kale, brussels sprouts, broccoli, collard, turnip, radish and cruciferous weeds. Its development in a plant is noted by decided yellowing, followed by dying of all affected parts of the leaf, the margins having a burnt appearance; the veins become brown or black and dark rings are observed in the stump. When leaves are removed at the stump, the fibro-vascular bundles appear as small black spots on the leaf scars. If badly infected the plant is dwarfed or makes a one-sided growth and often fails to mature. On account of black streaks, the heads are unsalable and frequently rot and fall off before a marketable size has been attained.

Infection occurs through tiny drops of water on the margins of the leaves, through wounds caused by tillage or insect attacks and through the roots. Experiments at the Geneva station show that pulling and destroying the diseased leaves is not satisfactory. By this radical treatment the yield was reduced $3\frac{1}{2}$ to $5\frac{1}{4}$ tons an acre as compared with undisturbed plants.

Infection may occur from the use of seed contaminated with the germs. To avoid trouble from this source, the seed should be soaked 15 minutes in formalin solution, made by dissolving one pound of formalin in 30 gallons of water. Other preventive measures are rotation, the destruction of cruciferous weeds and insect enemies, and the use of soils and manures free from the disease germs.

369. Other diseases.—Although club root and black rot are the most important diseases of the cabbage, the following cause more or less trouble: Leaf-spot (*Sphaerella brassicaecola*); stem canker and drop (*Phoma oleracea*); mildew (*Peronospora parasitica*); a dark rot (*Scotinia libertiana*), studied by the Missouri Botanical Garden; a bacterial soft rot closely related to *Bacillus carotovorus*; root rot or stem rot (*Corticium vagum*); and white rust (*Cystopus candidus*).

370. Sauerkraut.—It is often desirable to make kraut when the market is weak, or when there is a considerable quantity of soft and burst cabbage. The process is very simple. After removing the cores and outside leaves, the heads are sliced or shredded by special devices or machines. The finely cut cabbage is then placed in barrels in successive layers of about 6 inches, salted slightly and pounded. This operation is repeated until the barrel is nearly full. About one pint of salt is required for a barrel of kraut. The cabbage is then covered with a cloth, and boards cut to fit loosely in the barrel are heavily weighted. The brine formed by the salt and the juice should cover the cabbage during the acetous fermentation.

In one of the large kraut factories, the cleaned and cored cabbage is placed in conveyors which carry it to the shredders. The cut cabbage is then conveyed to the upper floor of the plant, where it is properly salted, and then dumped into a long chute which delivers it in large tanks on the first floor, to be mixed and packed. The

stamping and packing is done by men with new rubber boots. The time required for curing depends largely upon the weather, but it usually takes from two weeks to a month. While in the tanks the cabbage must be watched carefully to see that it is kept under the brine. When fermentation is thought to be complete samples are secured for testing from the interior of the tank by means of a long wire hook. The kraut is then removed and packed in cans, kegs and barrels. No vinegar or other foreign substance is used in this factory to sour the cabbage.

CARROT (*Daucus carota*)

371. History and importance.—The carrot, native to Europe, has been in cultivation for 2,000 years. This vegetable is far more appreciated by Europeans than by Americans. It is not only grown extensively in European fields and gardens, but is popular for forcing purposes. In the United States it is an important crop when a large city market is available, but sales are very limited in the smaller centers of population. The unpopularity of this root crop is doubtless partly due to a lack of proper knowledge regarding its preparation for the table. The large roots of late varieties are grown for stock feeding and are regarded as especially valuable for horses.

372. Soil.—The smoothest and best-shaped roots are grown in distinctly sandy soils. Perfect drainage is essential. In addition the soil should have very little tendency to bake. It should be fine, mellow, fertile and moist. The young carrot plants are very delicate, and for this reason freedom from weed seeds is especially important. Heavy manuring and clean cropping the previous year provide the best conditions.

373. Climate.—This vegetable adapts itself to a wide range of climatic conditions. While it is hardy, both

tops and roots being able to stand some freezing, it will not resist the severe cold of northern winters.

374. Varieties.—If the season is long, and early varieties are planted, the roots may send up flower stalks the first year. In such cases the carrot is an annual. The late varieties are biennial. The roots of the wild plants are slender and woody, but those of cultivated varieties vary greatly in every particular. They may be pointed or blunt; long, half-long, short or globular; the flesh may be white, yellow or purple. Goff (N. Y. Sta. Rep. 1887, p. 133) made the following classification:

A. Root distinctly pointed.

B. Root long, the length exceeding four times the diameter.

c. White,

cc. Yellow,

ccc. Orange or red,

cccc. Purple.

BB. Root half-long, length not exceeding four times the diameter.

(Color divisions)

AA. Root distinctly premorse, or blunt at the lower end.

(Root and color divisions)

Professor Goff classified 28 varieties, the following groups embracing the most important:

(1) EARLY SHORT SCARLET, EARLY SCARLET HORN, are popular, very early short-rooted varieties.

(2) CHANTENAY or MODEL, DANVERS HALF-LONG ORANGE, HALF-LONG SCARLET, OXHEART and RUBICON are largely planted as medium early varieties.

(3) LONG ORANGE is the leading late, long-rooted variety.

(4) WHITE BELGIAN is a large-rooted sort grown and valued for stock feeding.

375. Planting.—Most of the carrot seed used in the United States is grown in England, France and Ger-

many. When the roots are wanted for seed production they must be properly preserved over winter and planted in the open as early as possible in the spring, about 2 x 4 feet apart, to provide sufficient space for the lateral spread of the tops, which attain a height of from 2 to 4 feet. For the production of an early crop of roots, the seeds must be sown as soon in the spring as the ground can be prepared, the short or globular varieties being used for this sowing. A succession of roots is secured by planting the same variety at intervals of two to three weeks or by sowing early, medium and late varieties at the same time. As many consumers prefer the smaller roots, it is customary to use early, small-rooted sorts throughout the season, although the half-long varieties are more largely planted for midsummer, fall and winter use. From 8 to 10 weeks are required to mature the earliest varieties and four or five months for the late. The latest varieties should not be planted in most sections after the middle of June.

Various planting distances are used by different growers. Ten or 12 inches between rows is sufficient space for the small early varieties and 15 inches is ample for any variety if a hand wheel hoe is to be used in cultivating. Some growers prefer to plant 24 to 30 inches apart and then cultivate with a horse.

The necessary amount of seed depends mainly upon the variety and size of roots desired. The small roots are sometimes grown an inch apart in the row, when much more seed is required than when the roots are grown 4 to 6 inches apart. Ordinarily it takes from two to three pounds of seed to plant an acre, or one ounce to 300 feet of drill. For the smallest roots 15 to 20 seeds a foot of row will not be too many, while less than half this number would be satisfactory for late varieties and larger roots. Thinning is universally practiced to secure large roots of uniform size, the distance between plants

varying from 3 to 7 inches; 4 or 5 inches, however, provides sufficient space for the development of most varieties.

Carrot seeds germinate slowly, and it is an advantage to sow enough radish seeds with the carrot to mark the rows. Tillage operations may then begin sooner, in order to conserve moisture and control weeds. The seed should not be covered deeper than necessary to furnish the proper supply of moisture; ordinarily $\frac{1}{2}$ to 1 inch of soil is sufficient.

376. Fertilizing.—The carrot, like other root crops, requires a liberal amount of potash. According to Voorhees, a yield of 15 tons an acre will remove 153 pounds of potash, 48 pounds of nitrogen and 27 pounds of phosphoric acid. These figures indicate the importance of using a high-grade fertilizer. It is likely that a mixture carrying 4 per cent of nitrogen, 6 per cent of phosphoric acid and 10 or 12 per cent of potash will give the best results under most conditions.

Fresh stable manure should never be applied immediately before planting carrots. Rotten manures of any kind may always be used to advantage, and may be applied in liberal amounts.

377. Cultivation should begin as soon as the rows can be seen and repeated at frequent intervals. The knife or wing-form of attachments to wheel hoes should be used at first, to avoid covering the delicate plants. Later, spike-toothed tools may be employed, to secure a deeper mulch of loose soil. More or less hand weeding and hoeing is necessary to destroy weeds in the row.

378. Marketing.—It frequently pays to pull and market early carrots before they have reached maturity. This may be a thinning process, by which the remaining plants may be given more room to develop. When the entire crop is removed at one time, and the roots are long, a plow may be run close to the row with cut



FIG. 73. PREPARING CARROTS FOR MARKET

edge of the furrow next to the plants, and the roots can then be pushed sideways and pulled with ease. The early roots are nearly always bunched. (Figure 73.) It is important to wash the roots well and to grade them carefully before sending to market. Later in the season they are sold in bulk, packed in baskets, crates, hampers or barrels.

Carrots are easily held in storage in the manner explained for beets (325). They keep better if not too ripe when harvested. Although yields of 500 bushels an acre are sometimes reported, 300 is considered a good crop.

379. Carrot beetle (*Ligyris gibbosus*) is the most destructive insect enemy of the carrot. It resembles the May beetle, although smaller, and measures from $\frac{1}{2}$ to $\frac{5}{8}$ of an inch in length. The beetles, which are reddish brown to black, cause most of the injury by feeding on the young plants. They feed mainly under ground and are difficult to control. They also damage sweet potatoes, Irish potatoes, corn, celery and various root crops.

CAULIFLOWER (*Brassica oleracea*, var. *botrytis*).

380. History.—Cauliflower is of European origin and has probably been developed from broccoli. It is generally regarded as the most refined and the most delicate member of the cabbage family. When properly prepared for the table, it is unquestionably the most delicious representative of this group of vegetables. The heads, which are simply the shortened and thickened parts of the flowers, may be cooked and pickled or prepared for the table as cabbage or Brussels sprouts. Cauliflower was probably first grown in this country for commercial purposes on Long Island.

381. Importance.—For many years cauliflower has been a very important field and garden crop on Long Island. There are immense areas at the east end of the

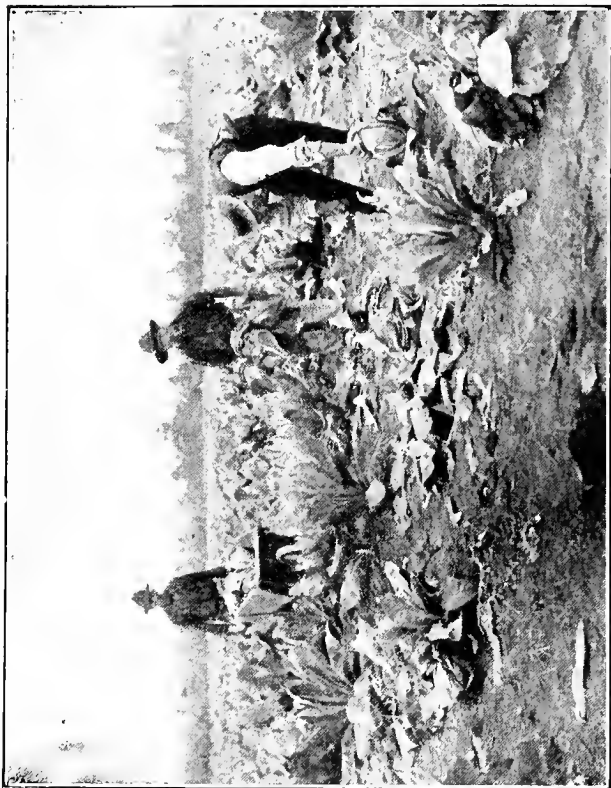

FIG. 74. LONG ISLAND FIELD OF CAULIFLOWER. COLLECTING FOR MARKET

island and many small but highly intensive ones near Brooklyn at the west end. Its cultivation has been extended to most of the states, but the crop is especially important in California, Florida, the Great Lake district and in other sections providing suitable climatic conditions.

Except in the most favored sections, it is a difficult crop to grow. Many uncertainties attend its production. The young plants are very susceptible to damping-off fungi. A hard frost may stunt the growth of the young plants, causing the heads to "bolt" or "button"; that is, the heads may break or send up their flowering parts before they have attained a marketable size. Poor seed or dry weather at the time of heading may cause the same trouble. Because of the uncertainty thousands of growers do not attempt cauliflower culture. Although the supply is liberal at times in some of our large markets, most cities are only fairly well supplied, and there is usually a good demand for large, white heads.

382. Climate.—Proper climatic conditions are universally regarded as more important than a congenial soil. This vegetable has become accustomed to a cool, moist climate; it rebels against heat, dry weather and low humidity. Regions near large bodies of water, as on Long Island, along the Atlantic Coast, in the Great Lake district and at Puget Sound, furnish ideal conditions. Some inland sections, however, have produced fairly good results. Growers in Garrett County, Md., have had splendid success. They are located about 3,000 feet above sea level, where the air is cool, and where there are fogs or a moist atmosphere most of the time. High temperatures, low humidity and lack of soil moisture tend to check growth, and therefore, reduce the size of the heads, which are thus probably caused to "button." Overhead irrigation is especially valuable for this crop.

The plants are much less hardy than cabbage. This fact must be taken into account when planting in the

spring and also when harvesting in the fall. Although they stand some frost, severe freezing should be guarded against at all times. Figure 74 shows a Long Island field of cauliflower.

383. Soil.—A constant and liberal supply of moisture is the most important factor in a soil; good drainage, however, is also essential. The rich, heavy loams provide excellent conditions, although splendid crops are often produced in light soils. Low, well-drained bottom land, even if sandy, produces good results if climatic conditions are satisfactory.

384. Varieties.—Three varieties of early cauliflower are grown extensively. Dwarf Erfurt is one of the best known; Snowball is popular in many sections; and Snowstorm is valued, especially for forcing.

Seafoam and Dry Weather are important late varieties, regarded particularly valuable for inland sections. Algiers and Autumn Giant are also planted for the late crop.

385. Seed.—Most of the cauliflower seed used in the United States is grown in Denmark. For seed production, still more favorable conditions must prevail than for the development of heads. Certain sections of Denmark, particularly in the vicinity of Copenhagen, furnish these requirements. While the bulk of our seed is imported, the Puget Sound region has been growing some high-grade seed. A great deal of inferior seed is offered to the trade. The best seed ranges in price from \$3 to \$7 an ounce. This amount should be sufficient to start 2,500 to 3,000 plants.

386. Raising early plants.—Early cauliflower plants are started in the same way as early cabbage, but greater care must be exercised. The soil should be sterilized and made only moderately rich. There should be a constant supply of moisture in the beds or flats, but overwatering

must be carefully guarded against. Free ventilation is important. The aim should be to produce a moderate, healthy, unchecked growth from seed sowing until the plants are established in the open ground.

As cauliflower plants are more tender than cabbage plants, it is customary to sow somewhat later, March 1 probably being early enough for the coldest sections of the North. The plants will then be ready for the field early in May, after the danger of hard frosts. Many growers prefer to transplant when the seedlings are very small, not more than an inch high. Planting them 2 x 2 inches apart does not give too much space, but provides free circulation of air around the plants, which may be removed from beds or flats with plenty of soil or compost, so that growth will not be materially checked. An excellent plan is to transplant into flower pots, which are then plunged in sand or ashes to prevent drying out.

387. Raising late plants.—Methods relating to the growing of late cabbage plants (350) apply equally well to late cauliflower, except that more care must be taken. As the seed is much more expensive, it should be sown more sparingly, so that each seed will produce a good plant. Some gardeners prefer to transplant once before setting where the crop is to mature. When this is not done the transfer should be made before the plants are too large and when both soil and atmospheric conditions are favorable.

388. Fertilizing.—The cauliflower requires even greater fertility than cabbage. Rotten manure should be used in large amounts—50 tons an acre, if obtainable at reasonable prices. A ton or more of high-grade fertilizer to the acre can also be used to advantage. Lime is regarded as valuable and is used extensively as a preventive of club root.

389. Planting.—The early plants should not be planted in the open until after danger of hard frosts. The late

plants may be set from the latter part of June until August 1, as the locality and the condition of the soil may permit. The general practice is to plant early enough so that the heads will form before the hot midsummer weather, and to start the late plants so they will begin heading with the lower temperatures of the early fall months. Although the crop may be and is matured at midseason, the task is regarded as difficult, because heading does not progress so satisfactorily in hot, dry weather. The planting distances are the same as for early and late cabbage.

390. Cultivation.—Clean tillage is required to prevent weed growth and to conserve moisture. In the small, intensive plantations, wheel hoes are used extensively; in field culture, the spike-toothed cultivators are most popular.

391. Protecting the heads.—The market pays the highest prices for pure white heads, but these cannot be produced without protection from rain and sunshine. This is accomplished by fastening the leaves over the heads in such a manner as to shed rain and to prevent the sun's rays from reaching the delicate heads. The operation should be attended to when the heads are small. Sometimes several leaves are brought together and tied. Some growers prefer to break or bend a number of outside leaves over the heads. This plan is not very thorough. Toothpicks are effective in fastening the leaves.

392. Marketing.—As cauliflower is one of the most delicate and easily damaged vegetables, it should be handled with the greatest care. It is often packed in barrels, which are far from being ideal packages for such a perishable product. Crates are better and are gaining in popularity. They usually hold about two dozen heads, but the one-dozen crate provides still better carrying conditions. Basket hampers are used sometimes. (See Figure 75.) The product should go to market in the most dainty condition; paraffin paper wrapped about

each head will help to accomplish this purpose. Such a plan is particularly desirable when prices are high.

393. **Returns.**—Returns are extremely variable, ranging from \$100 to \$1,000 or even more an acre, \$400 an acre being a highly satisfactory return.

394. **Insects and diseases.**—The same as of cabbage. See paragraphs 363, 364, 365, 366, 367 and 368.



FIG. 75. CAULIFLOWER PACKED FOR MARKET

CELERIAC OR TURNIP-ROOTED CELERY (*Apium graveolens*, var. *rapaceum*).

395. **Culture.**—This umbelliferous plant belongs to the celery species. The root is the edible part. It is used for flavoring, as a salad and for cooking, like other root crops. The roots vary in size from 2 to 4 inches. They may be stored during the winter under the same conditions as beets or turnips. This vegetable is of

minor importance in America. It is used more largely in foreign countries, especially in Germany.

Its culture is practically the same as for celery. The early crop may be started under glass and transplanted to the open when there is little danger of severe frosts. As the plants are not blanched, less space is needed between rows than for celery when banked with earth. For the late crop, sow in the open at the same time as for late celery and transplant where the crop is to mature. Soil thrown over the roots in the fall will whiten and protect them until early winter, when they may be stored.

CELERY (*Apium graveolens*).

396. History.—The wild celery is native to southern England, Europe and Asia. Very little is known concerning its early history, but it was probably not cultivated until after the Middle Ages. The many varieties of merit now in cultivation are the developments of comparatively recent years. As late as 1880 this vegetable was unknown to many American people and very little was grown for commercial purposes. It was then regarded as a luxury, selling at very high prices, for use in garnishing and flavoring, as well as for salad purposes.

397. Importance.—Celery as a food and as a relish was not fully appreciated until within the past few years. It is now universally regarded as one of our most important vegetables. Immense quantities are grown for commercial purposes and no home garden is complete without it. Its uses are varied: the leaves are excellent for garnishing and seasoning; the seeds impart a pleasant flavor to soups, salads, pickles and other dishes; the thick, fleshy leaf stems are especially valued during fall and winter, when meats are used so generally and when other salad crops are not so plentiful as earlier

in the season; the stalks are also cut into short pieces and cooked, seasoned with cream and butter and served like salsify or asparagus. It is one of our most wholesome and palatable vegetables, although the nutritive value is not high.

Thousands of cars of celery are grown annually in the muck soils of the large producing districts. The most extensive areas devoted to this crop are in the Great Lake region. Thousands of acres of muck lands are used annually for celery culture in Michigan, Ohio and New York. The industry has also become of great importance in California and Florida. With the varied climatic conditions of the different states which are producing celery on a large scale, our markets are well supplied during most of the year. Eastern growers as well as western producers begin marketing in July or earlier and continue to supply the trade until January. Florida and California crops are ready the latter part of December and meet the demands until late in the spring.

Intensive market gardeners of the North consider celery one of their most profitable crops, and with the overhead system of irrigation its culture is being rapidly extended.

398. Botany.—Celery belongs to the family of plants known as *Apiaceæ*. The botanists formerly classed this vegetable under *umbelliferæ*. It is usually biennial, although, if seed is sown too early and the plants are checked in growth, they may produce flowers the first year. This is sometimes a source of heavy losses in large plantations of early celery. The flower stalk is 2 to 3 feet high, branched and leafy; the flowers are white, inconspicuous and borne in compound umbels; the seeds are very small and flattened on the side; the leaf stalks are 6 to 15 inches long and bear three pairs and a terminal leaflet coarsely serrate and ternately lobed or divided. The wild plants have an acrid, pungent flavor.

399. Varieties.—There are two general classes of celery, namely, the green varieties and the so-called self-blanching varieties. The self-blanching class did not appear until 1884, or a few years earlier in trial grounds. It has revolutionized commercial celery culture, for probably 90 per cent of the crop now produced for market belongs to this type. Since the plants are easily blanched by means of boards, the rows may be much closer together than for green sorts, and, therefore, possibilities are very much greater. The self-blanching character is the result of breeding and selection. Although commercial possibilities have been increased, the plants have lost in constitutional vigor, being less hardy and resistant to disease, and have also deteriorated in quality.

WHITE PLUME was introduced in 1884 and of the self-blanching varieties was for several years grown most largely. It still finds favor among many commercial growers. The stalks are tall and require very little artificial blanching, but in quality it is somewhat inferior to Golden Self-Blanching.

GOLDEN SELF-BLANCHING is by far the most extensively grown variety in all sections, early and late and for all purposes. It attains a height of 14 to 20 inches. The plants are stocky and compact, the foliage is abundant, and the stems short, thick, and easily blanched to a creamy white. It is the most important commercial variety.

ROSE RIBBED GOLDEN SELF-BLANCHING is similar to the Golden Self-Blanching except that it has a tinge of rose color on the ribbing of the stems.

GIANT PASCAL is an old green-stem variety, valued for its long stems and high quality. The plants in rich, moist soils grow to the height of 30 inches or more, making blanching rather difficult. It is planted only as a late variety.

WINTER QUEEN is another popular, largely grown late variety. It does not attain as great a height as **Giant Pascal**, and is more convenient to store.

FRENCH SUCCESS is a stocky, compact winter variety of excellent keeping qualities.

BOSTON MARKET, a low, dwarf-growing variety, is especially popular in Boston. When thoroughly blanched with soil the stalks are extremely tender and delicious in flavor. No variety excels it in quality.

Many other varieties are described in the seed catalogs and some of them are excellent.

400. Climatic requirements.—Celery is grown successfully in all parts of the United States. Certain climatic conditions, however, are known to be especially favorable for its most successful culture. Low humidity, plenty of sunshine, considerable warmth during the day and cool nights provide ideal conditions. Diseases are less troublesome when the air is dry, and a rapid but strong, healthy growth is encouraged by sunshine and relatively high, dry temperatures. Cool nights make the stems firm and crisp. Most northern sections provide excellent conditions during summer and fall, while some parts of the South, especially Florida, possess the proper climatic conditions for winter culture.

Although celery is one of our hardy vegetables, it will not stand severe freezing without sustaining injuries. The young plants are likely to be checked in growth by hard spring frosts which probably cause them to produce seed stalks. The matured plants are often damaged or killed by severe freezing. Vigorous plants will generally stand a drop of seven degrees below freezing, although this will impair the keeping quality. A liberal rainfall, well distributed during the growing season is necessary unless irrigation is possible.

401. Soils.—The great commercial plantations of celery in the states bordering on the Great Lakes, in Cali-

ifornia and in Florida are upon muck soils. In Florida these areas are known as "hammock soils" and "saw-grass marshes." They vary from 1 to 10 feet or more in depth and are formed of decayed vegetable matter. There should be a depth of not less than 18 inches of muck to secure the most satisfactory results. In the best celery mucks the water table is about 3 feet below the surface. In such soil the crop will not suffer seriously during drouth. When the water table is near the surface the soil is soft and difficult to work with horses and there is also danger of an excessive amount of water in wet seasons.

The following is an analysis of a Kalamazoo muck soil (Mich. Sta. Bul. 99, p. 12) used for celery:

	Per cent
Sand and silicates.....	19.16
Alumina.....	1.40
Oxide of iron.....	3.94
Lime.....	6.09
Magnesia.....	0.81
Potash.....	0.34
Soda.....	0.38
Sulphuric acid.....	1.31
Phosphoric acid.....	0.88
Carbonic acid.....	1.95
Organic matter (containing 2.53 of nitrogen).....	63.76
Water.....	6.51

Other analyses published in the bulletin referred to indicate that there is very little variation in the composition of Michigan mucks.

When cleared, muck soils are often very acid and require large applications of lime before they will produce the best crops of celery. The accumulation of alkalis in irrigated lands of the West is not apparently injurious to the growth of celery. A first-class muck is brown-black in color, friable, free from coarse, fibrous material and will produce no change on blue litmus paper. Sour mucks are unfit for cultivation until, in addition to liming, they are weathered by being exposed to the action of frost during the winter.

Muck soils are especially adapted to celery because they are moist, fertile, loose and friable; they are also easily worked, so that it costs less to grow a crop in such lands than in other soils. It is very generally admitted, however, that the characteristic flavor is somewhat lacking when celery is grown on muck soils.

While muck soils possess marked advantages for very extensive cultivation of the crop, splendid returns may be obtained on any soil that is deep, moist, fertile and well drained, sandy loams being preferred. Many clay and silt soils produce excellent crops, especially when well manured and irrigated. The introduction of modern methods of garden irrigation has made it possible to grow this crop at a profit wherever favorable market conditions can be found.

402. Sources of seed.—The planting of high-grade seed is of prime importance, for poor seed may cause pithy or hollow stalks, a running to seed the first year, a failure to get a good stand of plants, and a lack of vigor and uniformity. Practically all of the seeds of the self-blanching varieties are grown in France. Excellent seeds of the green sorts are produced in California. Growers of the Boston Market use seeds produced near Boston. Since great skill and care are required in the growing of celery seed, gardeners should purchase their supplies from the most reliable dealers. Some commercial growers import from specialists in order to be absolutely certain of getting good seed. This is unnecessary, however, if the most reliable dealers in this country are patronized.

Fresh seed is advocated by most growers, although a few careful gardeners prefer to buy large quantities from various sources, and then use the best from year to year until the supply is exhausted. If kept in sealed glass jars where the temperature does not vary greatly, the germinating power of the seeds will be retained from six

to eight years. The plants from very old seeds lack vigor and are probably more susceptible to disease than those from fresh seed.

403. Propagation.—It is seldom best to sow for the early crop before March 1 in most northern sections. If sown earlier, special care must be exercised to avoid checking the growth before the plants are set in the field, for the fact seems to be well established that any hindrance of growth in seed bed, cold frame or field will be likely to cause seed production the first year. As the plants cannot be set in the open with safety until after May 1, it is difficult to maintain an unchecked growth when the seed has been sown very much before March 1.

Celery seed, being very small and slow to germinate, must be provided with the best conditions in the seed bed. The soil should be fine, moist and not given to baking. Muck is excellent when available. It is improved by the addition of finely sifted coal ashes, some sand and a small quantity of bone meal. If muck is not at hand, use any rich garden soil to which has been added liberal amounts of sand and fine rotten manure.

The seed may be sown in flats or in the soil of the hotbed or the greenhouse. If flats are used, the soil must be moist and well firmed, especially in the corners and along the sides. The seeds are sown thinly in rows 2 inches apart. The furrows are made very shallow, so that the seeds will not be covered with more than $\frac{1}{8}$ inch of soil. After the seed is covered a piece of burlap is placed over the flat or the bed and the soil moistened by sprinkling the burlap. If possible, a temperature of about 70 to 75 degrees is maintained until the plants are up. The plants must then have plenty of light, sunshine and fresh air. They should be watered as often as necessary to keep the soil moist, but overwatering must be avoided. Many gardeners cover the beds with cloth while the seeds are germinating. It is an advantage

to water between the rows, and thus the foliage is kept dry. The soil should also be stirred occasionally, and the temperature kept sufficiently high to maintain a healthy, vigorous growth. Thinning is done if the plants stand too close together.

When losses have previously occurred from damping-off fungi, the only safe course is to sterilize the soil with steam or formaldehyde. When the latter is used, a mixture of 2 pounds of formaldehyde with 5 gallons of water will give good results. Some growers also sterilize the seed by placing it for a few minutes in a solution made by adding 2 ounces of copper sulphate to $\frac{1}{2}$ gallon of water. The seed should be dried thoroughly after this treatment.

When the rough leaves appear, the tiny seedlings are transplanted into flats or beds. An inch and one-half each way is generally ample space, and some growers plant only $1\frac{1}{4}$ inches apart, but if to be held for a longer period than usual, plant 2 by 2 inches apart. Before planting, the flats should be about half filled with rotten manure and then completely filled with a good garden soil containing plenty of rotten manure and some sand if available. The boxes should be kept in the hotbed or the greenhouse until the plants are well established and are making a vigorous growth. Then if the weather is not too cold, they may be taken to the cold frame. This transfer is a critical operation, unless proper care is exercised in providing the right temperature. Young celery plants require about as much heat as tomato seedlings. A desirable precaution against fungous diseases is to spray with bordeaux mixture before taking to the cold frame as well as to the open ground.

Seed for the late crop is usually sown in the open or in protected beds as early in the spring as the ground can be prepared. A moist seed bed is very important. Fall plowing will assist in securing the proper supply of

moisture. There are various methods of starting plants out of doors, but if the fundamental principles are understood, there should be no trouble in getting a good stand of plants. There must be a full supply of moisture for not less than two weeks, and the soil must be sufficiently friable to permit the delicate plants to push through to the surface. A liberal proportion of humus will make conditions more favorable.

The land is often thrown up into beds, although this is unnecessary in well-drained gardens. Sowing in drills is much better than broadcasting, because the soil may then be cultivated. The seeds should have a slight covering of fine soil and the beds or rows watered, if necessary. The overhead system of irrigation is especially valuable in starting celery plants in outdoor seed beds.

In some sections it is necessary to start the plants for the late crop in beds protected by board windbreaks and by cloth coverings. In other sections, when the sun is particularly hot, cloth or lath screens must be provided to shade the plants until they are well established.

The rows are generally 1 foot apart. This provides plenty of space for wheel hoe cultivation until the plants are transplanted. The usual practice is to transfer from the seed bed to ground where the crop is to mature. Some growers prefer to transplant once before setting in the field, and thus secure stronger and more vigorous plants. When this intermediate shift is not made, the plants should be thinned to induce stockiness.

404. Soil preparation.—In the North new muck land is usually plowed and sometimes subsoiled in the fall. The winter exposure to frost improves the structure and prepares the soil for cropping the next year with corn or some other cultivated crop. In most instances, celery should not be planted until the second year. Whatever the character of the land, early plowing is important.

Sandy loams and heavy soils require frequent and thorough harrowing. A smoothing harrow and a plank drag or leveler should be used to make the soil fine and smooth before planting.

405. Fertilizing.—In making plans for the fertilizing of this crop the grower should bear in mind, (1) that the plants are shallow rooted; (2) that they prefer soils abounding in vegetable matter; (3) that rapid growth is essential to high quality, for plants which grow slowly are not so crisp, sweet and tender.

Stable manures are undoubtedly the best fertilizers for celery, because they not only supply plant food, but also humus. Irrespective of soil type or location, all growers use manure if it can be obtained at reasonable prices. Horse manure is most generally employed, although cow manure is preferred by some gardeners. The amount of manure to the acre varies from 10 to 50 tons. Many of the most intensive growers, who figure upon gross returns of not less than \$1,000 an acre, apply at least 50 tons, but excellent results may be secured with half this amount if supplemented with commercial fertilizers. Ten tons annually on muck lands may produce good results, but the largest profits are seldom, if ever, secured without the free use of stable manures.

Rotten manure is preferred by many growers while others make winter applications of fresh manures. When the latter plan is practiced the manure should be chopped up and thoroughly mixed with the soil by a disk harrow before plowing. The best results from rotten manure are obtained from dressings applied after plowing, the most approved plan being to spread broadcast. Formerly, many growers bedded the manure in trenches or furrows before planting, and some continue the practice. Mulching with manure is described later.

406. Commercial fertilizers.—While some sections rely wholly upon stable manure, high-grade commercial

fertilizers can always be used with profit. It is customary to use a large percentage of nitrogen. Four per cent can probably be used to advantage in all instances and 6 or 8 per cent would be profitable under certain conditions. Eight or ten per cent of each of the mineral elements should be used. An excellent plan is to use at planting a 4-8-10 fertilizer, and top-dress with nitrate of soda at intervals of two or three weeks to obtain additional nitrogen. The first application of nitrate should not be made until the plants are well established, and then 150 pounds an acre should be distributed along the rows. Two hundred pounds may be used at each subsequent application. Soft or pithy stalks are sometimes attributed to too much nitrogen. It is claimed that the free use of the mineral elements will counteract this effect, producing firmer stalks. Many intensive growers use two tons or more of high-grade fertilizer to the acre, while a ton is a common application, but inadequate for the largest returns.

407. Planting.—As previously explained, plants for the early crop should not be set in the open until after danger of severe frosts. In most sections planting should not occur until May 10 or 15. Strong, vigorous plants properly set at this time should produce a marketable crop by August 1. The late plants may be set the latter part of June and throughout the month of July, depending upon variety, soil, weather and climatic conditions.

If the plants are more than 5 inches high at the time of transplanting, it is an advantage to clip the tops. This operation is sometimes repeated several times in the seed bed to induce stockiness.

The ground should be fine, smooth and moist before transplanting is begun. It should also be fairly firm and marked at the required distances. Various forms of markers are employed, but shoe and roller markers are most popular. The roller markers may have pegs to

mark the place for each plant, to secure uniformity in spacing. They relieve the foreman of the annoyance of looking after this matter.

Planting distances are extremely variable. If soil is to be used in blanching, the distance between rows must be not less than $3\frac{1}{2}$ feet; 5 feet is the more common spacing, especially for the tall green varieties. Sometimes an early variety, as Golden Self-Blanching, is planted in alternate rows. This variety is blanched by means of boards. The distance in this case need not be more than 30 inches. After the early crop is sold there is ample space to blanch the late crop with soil. When boards or other devices are used for blanching the spacing between rows varies from 18 inches to 3 feet. In the most intensive plantations where boards are used, the distance between rows is usually from 20 to 24 inches. The standard distance between plants in the row is 6 inches, although there is a decided tendency to plant closer. Some of the best growers plant the early varieties only 4 inches apart and allow 24 inches between rows. At these distances 65,000 plants are required for an acre.

Double row planting is practiced occasionally. With this method the rows are about 6 inches apart, and either earth or boards may be used in blanching.

When the plants are set very close together both ways, as 8 x 8 inches, or closer, the method is known as "the new celery culture." Like other intensive methods, it is adapted to only very fertile lands where the supply of moisture can be maintained. With this plan there are usually 5 to 10 rows in a bed with 2-foot alleys between them. When all the points are considered, it is better to plant 4 x 24 inches apart, so that a wheel hoe can be used in cultivating. Close planting is not so well adapted to the green varieties because of the greater difficulty in blanching.

Transplanting can be done to better advantage in humid or cloudy weather. The plants should be lifted with care. If the seed beds or flats are watered 24 hours in advance of planting, the plants can be removed with more soil clinging to the roots than if unwatered. Some growers give little attention to this matter and often shake most of the soil from the roots. In this case the roots are usually puddled before setting, or the ground may be watered before and after planting. Dibbers, trowels, or the forefingers are used in making the holes to receive the plants, which should never be set deeper than they stood in flats or beds. Pressing the soil firmly to the roots completes the operation of transplanting.

408. Cultivation.—The ground should be cultivated as soon as possible after transplanting, precaution being taken not to throw any soil on the hearts of the plants. As celery is a shallow-rooted crop, tillage should never be deep; the ground should be stirred and hoed often enough to control weeds and to conserve soil moisture.

409. Mulching.—Pine needles, straw and other materials are used for mulching celery, but horse manure is very much the best mulch. It is not only an excellent conserver of moisture, but furnishes plant food as well. Some of the most successful intensive growers use the following plan for White Plume and Golden Self-Blanching and for summer, fall and early winter sales: The plants are set at the usual times, at distances of 4 or 5 inches by 24 inches. As soon as possible after transplanting, the ground is mulched with 40 to 50 tons of fresh horse manure to the acre. The manure should not be placed against the plants. If applied at the rate suggested, the mulch will be 4 or 5 inches deep at the centers of the row spaces, sloping gradually to the rows themselves. No tillage is given if the mulch is applied immediately after planting, otherwise the ground should be kept well stirred until mulched. The manure will be

thoroughly decayed by the following spring, ready for the next crop, whatever it may be. This plan has met with great favor in the Cleveland district, especially with growers using the overhead system of irrigation.

410. Irrigation.—Many of the finest celery plantations are irrigated. Production without artificial watering on soils other than muck is rather uncertain. Irrigation insures a crop on all soils provided other conditions are



FIG. 76. IRRIGATED FIELD OF CELERY

favorable. Figure 76 shows a system installed in central Pennsylvania. It is especially valuable in conjunction with mulching, as previously discussed (409). Nitrate of soda when applied broadcast may be dissolved at once by the spray, thus feeding the plants without waiting for rain to render it available.

The distribution of water through open ditches is the usual method employed in the irrigation sections of the West. Subirrigation is used extensively in the celery fields at Sanford, Fla.

411. Blanching.—The market in this country demands well-blanching celery, which is secured by requiring the

plants to grow when the leaf stalks are in darkness or subdued light. Growth under such conditions destroys the coloring matter of the leaf stems and prevents the formation of additional coloring matter. Any means of protecting the plants from light while they are growing will, therefore, secure light-colored stalks. Blanching

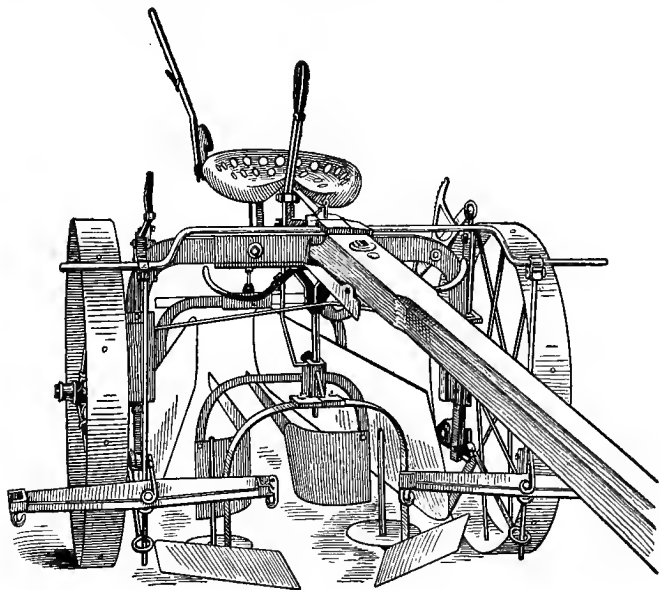

FIG. 77. CELERY HILLER

also makes the stalks tender and crisp and improves the flavor.

For many years, earth has been used most extensively for blanching. When blanched with soil the stalks possess a sweet, nutty flavor that cannot be obtained by any other method. Earth must not be used in warm weather because it causes rust, hence banking does not begin

until fall when the weather is cool. When the crop is to be stored in temperatures high enough to encourage some growth, the crop will blanch in storage and will keep better if not blanched at all in the field.

Ridging may begin with the cooler fall weather. Formerly all late celery was first "handled" before the ground was plowed up to the rows. Many growers continue the practice, while others do all of the ridging with special celery hillers. By "handling" is meant the pressing by hand of loose, moist soil about the base of each plant to make the stalks stand erect. Tillage precedes this operation, to provide plenty of fine soil. The hiller (Figure 77) is used immediately after "handling" and subsequently as the plants attain greater height. All of the work of ridging in some of the muck plantations is done with the hiller. Some of the successful growers in muck soils bank, so as to avoid getting much soil next to the bases of the plants, as the latter encourages rust. This is largely a process of shading by banking the earth as high as possible on both sides of the row. Earthing is the most effective means of protecting the crop from severe fall frosts.

The early crop is nearly always blanched by means of boards. It pays to secure sound lumber for this purpose. Hemlock is in common use. "Pecky" cypress is popular for blanching in the Florida fields. The boards should be 12 inches wide, 1 inch thick and 12, 14 or 16 feet long. Ten-inch boards are preferable early in the season before the plants have attained their full size. Half-inch strips nailed across the ends and the middles of the boards will help to prevent warping and splitting.

The early crop should be ready to begin blanching about the middle of July. Boards are placed on edge close to the row on both sides and fastened together with two or three 8-inch double hooks made from heavy galvanized wire. By placing these hooks over the

upper edges, the boards may be brought as close together as the tops of the plants will permit. From 10 to 20 days are required for blanching, depending mainly upon weather conditions. In warm, humid weather blanching proceeds much more rapidly than at lower temperatures. A light furrow of soil is often thrown along the lower edges of the boards to exclude the light. The boards are shifted to other rows as the crop is marketed. Thus the same boards may be used



FIG. 78. CELERY BLANCHED WITH BOARDS

half a dozen or more times during the season. Between seasons the lumber should be stored in the dry or stacked in flat piles, as in lumber yards. With good care, sound boards will last at least 15 years. Figure 78 shows a row which was blanched by this method.

Paper may also be used in blanching. A machine has been devised which first places a strip of paper against the row and then throws soil against the paper. The individual plants may also be wrapped by hand with brown paper, although this is a tedious operation.

412. Harvesting.—The proper time to harvest is determined by the size of the plants, the thoroughness of blanching, prices and the weather conditions. The market will sometimes pay better prices for very early celery, partly blanched and two-thirds grown, than for late, fully matured, perfectly blanched stalks.

Except in the very large commercial plantations the usual method is to lift the plants with a spading shovel or a fork. Some growers prefer to cut the roots at the proper depth with large, sharp butcher knives, a plan which is especially satisfactory in sandy or muck soils and when the crop has been blanched with boards. In the great producing sections, machines are employed to cut the roots. The machine is a very simple device drawn by two horses. It consists of a U-shaped steel cutter 5 or 6 inches wide and $\frac{1}{2}$ inch thick mounted beneath and between two wheels. The blade is adjustable, so that it may be set at any depth. When in operation a row is loosened as fast as a team walks.

It is customary to remove the worthless outside leaves before hauling to the packing shed, where the plants may receive further and more careful trimming. The roots are also cut as desired (413) in the field. The plants may be placed on trays or in boxes preparatory to hauling to the packing room. Whatever plan is used exposure to the sun and the drying air of the field should be as brief as possible.

413. Marketing.—In many instances the crop is shipped in the rough direct from the field to city storage houses, where the plants are trimmed and washed by the commission dealers before shipping or delivering to retailers. When this is the practice the plants are graded and a few of the outside leaves are removed before being packed in the field, but the roots are not cut off. The growers in several sections ship to the retailers without removing or trimming the roots, while most pro-

ducers find this a necessary practice. The roots may be cut off straight near the base of the stalks or tapered rapidly to a blunt point, the latter method being necessary when bunching flat as shown in Figure 79.

The flat method of bunching, i. e., the tying of three or four plants together, is popular on some of the eastern markets. The butts are always tied first, to give the spreading and arched appearance of the stalks, as illus-



FIG. 79. CELERY BUNCHED FOR MARKET. A ROUND BUNCH OF ONE DOZEN PLANTS ON THE LEFT, AND A FLAT BUNCH OF THREE PLANTS ON THE RIGHT.

trated in Figure 79. Many local growers prefer to tie in round bunches containing three or four plants, while the most extensive shippers tie in round or rectangular bunches of a dozen plants. Although jute is used by some growers in tying, pink, red or blue tape made for the purpose is very generally employed.

The washing may be done before or after tying, the more general practice being to wash before bunching.

When tied flat, washing after bunching is the more convenient way. The use of pure, cold water in washing is important from a sanitary standpoint. It also freshens and helps to preserve the celery in a firm, crisp condition.

Rigid grading is important, but often neglected. Some of the most careful growers and shippers make four grades. The culls or smallest sizes are used largely by hotels and restaurants and served as hearts.

The standard crate in many sections is 24 x 24 inches at the base. From 6 to 16 dozen bunches are packed in this crate, depending upon the variety and the grade of celery. Packs holding 6, 8, 12 or 16 dozen plants are common. Although the 24 x 24 inch crate is most frequently seen, various other sizes and forms are in use.

Michigan growers use crates which vary in size. Measurements made of a lot of packs on an express truck ready for shipment gave the following dimensions: 6 x 12 x 24 inches; 6 x 16 x 24 inches; 6 x 20 x 24 inches; 6 x 26 x 24 inches; 6 x 30 x 24 inches. The number of dozen bunches in the various crates varied from 4 to 24.

The early crop is often wrapped in rather heavy brown paper for shipment and the crates frequently lined with paper.

The crop is handled largely in refrigerator cars holding about 160 crates, small air spaces being provided between the crates. When packing in the field the growers endeavor to have the celery in the cars within two hours after lifting from the row.

Appearance when offered at the market has everything to do with the sale of celery. The stalks must be clean, well blanched, bright and free from rust or dead leaves.

414. Storing.—For the successful storage of celery the air should be kept cool and fairly moist. This crop should be stored before hard freezing weather and the tops should be dry when the plants are stored. Ventilation is generally necessary on warm days.

Home gardeners often protect the crop in the winter where it was grown by ridging the soil until the tops are nearly covered. Corn stalks or other coarse litter is then placed over the row and held in place with boards or earth. As the weather gets colder, coarse manure is added to the depth of 4 or 5 inches, covering the entire ridge. By this method the celery is kept fresh and crisp, but taking it out during the winter is rather inconvenient.

Other home gardeners store in cellars. The plan is successful in the absence of furnaces and heating pipes, for the room must be kept cool and moist. The plants are simply set close together with some soil about the roots and watered if necessary. Boards may be set up along the sides of the bedded plants to hold them in place and to protect them from light. Under favorable conditions there will be some growth and the plants will continue to blanch.

In certain sections market gardeners ridge as high as possible, place a line of hay or straw over the tops, cover with a strip of oiled paper made for the purpose and then cover the paper with more hay. This plan is particularly desirable in sections where the weather is not very severe.

Hotbeds and cold frames are very satisfactory. They may be dug to a greater depth if necessary, or an additional frame may be placed on the permanent frame to secure the required depth. The plants are set nearly as close together as possible, and the frame covered with boards lapped to shed rain. In severe climates, sash should be used, when straw or rye-straw mats may be placed on the sash and covered with lapped boards. The sash can be blocked up on warm days to secure the needed ventilation. This is a highly satisfactory method for all sections.

Trenching has long been a popular method for storing this crop. A trench 10 or 12 inches deep is dug in the garden or the field where the crop is grown. It should

be deep enough to receive the plants so the tops will not protrude more than about 2 inches above ground. Trenching in most sections may begin any time after the middle of October. When the tops are perfectly dry, the plants are lifted with some soil and set close together in the trench. The boards which have been used for blanching are nailed together in V form and placed over the trenched plants. If the weather is warm after trenching, blocks or stones should be placed under the edges of the boards to admit air. When the nights



FIG. 80. CELERY STORAGE HOUSE

become cold and there is some freezing, a light furrow of soil is thrown along the base of the boards. Later the boards are covered with manure, increasing the depth as necessary. Trenching is most generally used when the crop is to be sold rather early in the winter.

Temporary and permanent pits are often used when the crop is stored and managed as explained for hotbeds and cold frames.

Many growers have especially constructed houses. Figure 80 shows a house in Wayne County, Pa. The description which follows has been furnished by the owner.

“Our celery house is 50 by 150 feet, with walls $6\frac{1}{2}$ feet high at the lowest corner, and about $4\frac{1}{2}$ feet at the upper side. The walls are 14 inches thick, made of concrete, with a 2 to 3-inch air space in the center. These double walls are bound together by $\frac{1}{2}$ -inch iron rods, three to the square yard.

“Twelve windows are in the side walls, just under the plates or sills, while there are four in each end, just above the sills. The top of the wall is level, and the gable ends are of 7-inch studding, with flooring used on both sides, the north end being packed with straw. The painted iron roof is supported by 8-inch rafters, ceiled underneath with flooring. This space is also packed with straw or cheap hay. This roof is held up by 24 purlin posts, set on concrete abutments.

“The two double doors are large enough for a team to enter. They are opened by raising, being balanced by weight-boxes, hung over 16-inch sheave wheels. There are two sets of ventilators in each end, about 20 inches wide, and 12 feet long. These are double, hinged at the top, one opening outward. This one is held at different angles by ratchet irons, while the inside one buttons either open or shut. There is also a ventilator 1 foot wide the whole length of the roof, near the peak, on the east side. On the upper side, these doors are covered with iron roofing, and are held open or shut by ratchet irons. The under doors drop down when open.

“We have a walk in the center, two planks wide, on purlin beams, for convenience in operating the ventilators. The windows are in double sets, one outside of the wall, and the other inside, each half sliding open or shut, either to right or left. There is a brick chimney near the center of the house, as we need a stove for keeping an even temperature in very cold weather, and also for heating water while washing the celery. We do not like to let the temperature change very much, because

changes cause the condensation of moisture on the plants. This should be avoided. The house, which has been very satisfactory, will hold about \$2,000 worth of celery. It cost about \$2,700."

The city cold storage houses are used extensively for the care of the crop until celery from Florida and California begins to arrive. The crates, which are packed in the rough in the field, are placed, without further attention, in cold storage rooms, with provision made for the necessary air spaces between the crates. This is a convenient method for the grower, but the quality of cold storage celery is always inferior to that which has been held on the farm under more natural conditions.

415. Returns.—Small areas of celery sometimes produce at the rate of \$2,000 gross returns an acre. While this is unusual, it shows the great possibilities of this crop. Market gardeners who irrigate frequently secure gross incomes of \$1,200 an acre. When total receipts on a large scale amount to \$800 an acre it is considered excellent, while \$500 is more common perhaps. The cost of producing and marketing an acre of celery varies greatly. Beattie ("Celery Culture," p. 130) gives the following estimate:

Rental of land or interest on investment...	\$20 to	\$60
Ten days' team work, including hauling		
manure	30 to	50
Fifty cubic yards of barnyard manure.....	25 to	50
Commercial fertilizers	50 to	100
Seed and production of plants.....	10 to	25
Setting out plants	15 to	25
Cultivation and irrigation	15 to	25
Loss on lumber used in blanching	10 to	20
Cost of 350 crates and packing	60 to	100
	<hr/>	
Total	\$235 to	\$455

Celery commands a price of 10 to 75 cents a dozen plants. Twenty-five to 40 cents is the usual range of prices. Extensive commercial growers regard \$100 an acre as a fair net profit. Market gardeners usually do much better than this.

416. **Insects.**—The aromatic flavor of celery seems to serve as a repellent to insects, for this vegetable has no serious enemy. The following insects are sometimes troublesome: Grasshoppers, celery leaf tyer, celery



FIG. 81. TWO FORMS OF SWISS CHARD

caterpillar, zebra caterpillar, tarnished plant bug, celery looper, carrot rust fly and the little negro bug.

417. **Diseases.**—Several diseases of celery are sometimes serious. The most important are the blights (*Cercospora apii* and *Septoria petrosclini*, var. *apii*), leaf spot (*Phyllosticta apii*), and rust (*Puccinia bullata*). Bordeaux mixture is frequently used for the control of celery diseases. Some growers begin making applications in the seed bed and repeat at intervals until blanching begins. The early applications are doubtless most effective.

CHARD (*Beta vulgaris*)

418. Character and uses.—This vegetable is also known as Swiss chard, silver beet and leaf beet. The leaves are thick and broad and the leaf stalks large and fleshy. (Figure 81.) It is one of our best potherbs, although not appreciated nor well known among American gardeners. The leaf blades are prepared for the table like spinach, while the stalks and midribs are cooked and served as asparagus, being especially palatable when eaten on toast.

419. Culture.—Chard is of easy culture. The plants may be started under glass in February, transplanted in flats before being set in the open ground. They are hardy and when properly grown will stand severe freezing. While they may be started under glass to advantage, the usual plan is to sow in the field when common garden beets are planted. The rows should be not less than 18 inches apart. Twelve to 15 seeds to each foot of drill should give a good stand. When about 6 inches high, thin to 3 inches and later to 8 or 12 inches in strong soils. The thinnings (both leaves and leaf stalks) may be used as greens.

Lucullus is the most popular variety. The plants grow very rapidly and several pickings may be made during the season, the central bud and leaves being preserved for additional growth. With heavy mulching the plants will winter without injury in some parts of the North. They may be readily protected in cold frames, and forced early in the spring. Nitrate of soda is especially valuable for this vegetable.

CHICORY (*Cichorium intybus*)

420. Character and uses.—Chicory is a well-known European vegetable. It is used to some extent in the

large American cities. The roots are cooked like carrots, and when roasted also used as a substitute for coffee. The leaves may be cooked like dandelion. When well blanched they are prized for salad purposes.

421. Culture.—Any soil adapted to other root crops will grow good chicory. The roots are hardy, remain in the ground over winter and send up tender leaves early in the spring. Several cuttings may be made from the same plants. As soon as the ground can be prepared in the spring the seed should be sown in rows 15 to 24 inches apart and the plants thinned to about 3 inches.

CHIVE (*Allium schoenoprasum*)

422. Character and uses.—The chive or cive belongs to the onion family, and produces dense tufts of slender, hollow leaves valued for seasoning because of their mild onion-like flavor. The leaves may be used at any time during summer. As the terminal clusters of flowers are violet red, chives make an interesting plant for garden borders or edgings.

423. Culture.—Any good garden soil will grow chives. The plants are perennial and hardy, the roots remaining in the ground for many years. They are easily propagated by dividing and planting the roots early in the spring, or from seed sown $\frac{1}{2}$ inch deep in rows about 12 inches apart. Later the plants are thinned to 6 inches. The roots may be divided and replanted every three or four years.

COLLARD

424. Culture.—This is a form of kale grown in some parts of the South and occasionally in the North. The plants are started by the same methods as cabbage and set in garden or field about 3 x 4 feet apart. The leaves are used as greens.

CORN SALAD (*Valerianella olitoria*)

425. Character and uses.—This is an annual plant popular in Europe. It finds limited sale in this country. The leaves have a mild flavor and are valued for salad purposes, for greens and seasoning, and the curly varieties for garnishing. As the plants are sensitive to heat, they are grown as a fall or spring crop. They are hardy and may be wintered in the milder sections by protecting in cold frames, or with mulches where the winters are not too severe. Although the plants attain a height of nearly 2 feet, the young leaves are tender and delicious. Two crops may be gathered from the same plants.

426. Culture.—The soil should be fertile and contain a bountiful supply of nitrogen. Dressings of nitrate of soda may be made to advantage. For the spring crop, sow in the open as soon as the ground can be prepared, or in the fall as for spinach. For the fall crop, sow late in the summer. The seed should be sown thinly in shallow drills. The rows need not be more than 12 inches apart, the plants thinned to 6 inches. Irrigation is a great advantage in growing this crop.

CRESS

The piquant leaves of cress are used in salads and for garnishing. Three common forms are in cultivation. They belong to different genera, but all are members of the Cruciferæ or mustard family.

427. Water Cress (*Nasturtium officinale*) is a hardy, perennial, aquatic plant popular on all our city markets. The leaves of the prostrate plants are small and roundish. Water cress thrives best in shallow, running water which should be pure and clean. It may also be grown in moist or wet, shady places, but springs and brooks are preferable. With irrigation it is grown to perfec-

tion in all soils, although as a commercial enterprise, success is much more certain with favorable natural conditions. It is readily propagated by scattering the small seeds along brooks or about springs or by planting short pieces of the stems in wet soil. When planted in wet, shady spots or under irrigating lines the plants should be set 5 to 8 inches apart each way. They may be easily started under glass early in the spring and transplanted into flats 1½ inches apart and watered frequently.

428. **Garden or Pepper Cress** (*Lepidium sativum*), a popular European salad plant, is grown to a limited extent in the United States. It is an annual and one of the best early salad plants, easily grown in any good garden loam. Moist soils should preferably be very fertile, to encourage a rapid growth and the production of crisp, tender leaves. With favorable cultural conditions the leaves will be large enough to use in four weeks from sowing. Sow thickly in shallow drills about a foot apart. Conserve the moisture by frequent tillage and water artificially, if possible. Gather the leaves when wanted and allow another crop to develop. Garden cress is a spring and fall crop and does not thrive in mid-summer.

429. **Upland Cress** (*Barbarea vulgaris* and *B. proecox*) is the least important of the three forms. It is native to a large part of the United States, but is not cultivated to any great extent. It is perfectly hardy and does best as a fall or winter crop. The seed remains in the ground all winter and germinates in the spring. Cultural directions given for garden cress apply equally well to upland cress.

CUCUMBER (*Cucumis sativus*)

430. **History and importance.**—The cucumber is one of the oldest of our cultivated vegetables. It has been

cultivated in India for at least 3,000 years, but according to DeCandolle was not introduced into China until the second century before Christ. It was first grown in England in 1573. Cucumbers were grown by the earliest settlers in this country, and the crop has been increasing in commercial importance. It is used largely for slicing and pickling and to some extent for cooking. The main trucking districts of the South regard it as one of their standard crops. In some parts of the North it is grown on a large scale for pickling. It is third in importance of the vegetables produced under glass.

431. Botany.—The cucumber is an annual, belonging to the genus *Cucumis* and to the family *Cucurbitaceæ*. The stems are rough, creeping, angular and flexible, bearing tendrils and cordate obscurely five-lobed leaves.

Both staminate and pistillate flowers are produced in the axils of the leaves, the staminate appearing first generally near the bases of the stems. The flowers are large, yellow and usually on short peduncles. They require the assistance of insects to effect pollination. In greenhouses this is accomplished by means of bees or by hand pollination. There are two types of fruit—the English, long and slender, and the American, short and thick.

432. Varieties.—English varieties are not grown in this country except to a limited extent in greenhouses. The best representative of the American type is White Spine. It is especially desirable for slicing. For this purpose it is grown under glass as well as in the open. The various strains of White Spine are grown more largely than all other varieties combined. Several varieties are regarded as especially valuable for pickling. Among them may be mentioned Chicago Pickling, Boston Pickling and Fordhook Pickling.

433. Climatic requirements.—The cucumber is grown commercially, on a large scale, under a wide range of

climatic conditions. All the trucking sections of the South and of the Atlantic Coast are favorable to the production of the early crop, while the cooler summers of the North are well adapted to growing picklers. The plants are sensitive to frost as well as to extreme heat, but thrive under cooler conditions than the melons. Because of the short period required to mature the crop, there are very few sections in the United States where it cannot be grown successfully.

434. Soils.—The light sandy soils are best for the early crop, if earliness is the chief consideration; but yields are larger and the bearing period longer in the heavier soils. The cooler clay loams are often used for the late crop and for the growing of picklers. Whatever the type of soil, it should be moist but not wet.

435. Source of seed.—Practically all of the seed is grown in this country. Careful selection is important. Since market requirements differ somewhat, this factor should be considered when buying or when saving seed from the home planting.

436. Starting early plants.—Earliness is such an important factor in securing remunerative prices that many growers start some of their plants under glass. Greenhouses are most suitable for the purpose, although hotbeds, glass and cloth-covered frames are often employed. Formerly, inverted squares of sods were used extensively in which to start young plants. They are still popular with some growers. Rather thick, tough sods are cut in squares of about 6 inches, inverted and hollowed out to provide a receptacle for soil and seed. They furnish excellent conditions, but are troublesome to prepare and are not so convenient to handle as earthen or paper pots, berry baskets and dirt bands. The pots or other devices should not be less than 4 inches in diameter and should be filled with a light, rich, porous, garden soil. It is an advantage to place an inch of rotten manure in the bot-

tom of berry baskets or dirt bands before filling with soil. Six to eight seeds should be planted in each, and the plants then thinned to the strongest two or four. It is customary to leave only two plants, while a greater field area may be covered by starting four together and then spacing more liberally in the field than if there were only two in each hill.

The seeds should not be sown more than a month before the time for hill planting, for if too far advanced there will be danger of a check in growth when the plants are transferred to the field. A night temperature of 60 degrees and a day temperature of 70 are suitable for germination and the growth of the plants. The plants should be hardened by moderate watering and by free ventilation before setting in the field.

437. Soil preparation.—Early plowing and frequent harrowing before planting are important. It is often possible to grow a green manurial crop in the fall to plow down in the spring. For the early crop some growers prefer to throw up the land into slight ridges, thus securing better drainage and somewhat warmer soil conditions.

438. Fertilizing.—Large yields of high quality are greatly favored by a constant, unchecked growth, accomplished by providing proper physical as well as chemical properties of the soil. The roots attain the best development in soils abounding in vegetable matter. For this reason, stable manures have been found particularly valuable. They should be well decayed, unless applied a month or more in advance of planting. If the supply of manure is abundant, it may be applied broadcast, but it will go farther and produce better results in soils of moderate fertility when applied in the hills or furrows. A popular and successful practice in some trucking sections is to open the furrows about a month before it is time to plant, distribute the manure, turn back the soil and mix soil and manure thoroughly with a convenient form

of cultivator before planting. When planting in hills a shovelful or two is placed in each hill and often mixed with the soil.

Excessive amounts of nitrogen must be avoided in the commercial fertilizers. Four per cent is probably as much as should be used on any soil, but additional applications of nitrate of soda may be made if necessary. The mineral elements are needed in liberal supplies to encourage fruitfulness. Eight per cent of phosphoric acid and 10 per cent of potash will meet the requirements on most soils. From 1,000 to 1,500 pounds of complete fertilizer are common amounts to use on an acre. Fertilizer may be applied broadcast before planting or mixed in the hills or furrows. When manure is used in furrows an excellent plan is to incorporate the fertilizer by the same mixing.

439. Planting.—Planting should not occur until the ground is warm and there is practically no danger of frost. Some of the most extensive commercial growers plant seed at two different depths, the shallow plantings coming on first, and if these are killed or damaged by frost the later ones will be likely to escape. For the pickling crop in the North, June is a popular month for planting. Truckers and market gardeners often plant at intervals of 10 days or two weeks to secure a succession of cucumbers. Whatever the time or system of planting, seed should be used freely to make certain of a good stand. The surplus plants are easily pulled or chopped out with a hoe. The advantage of selection is an important factor.

Planting in hills was the universal practice some years ago and is still preferred by many growers. In good soils the distances between hills should be not less than 5 x 5 feet, and some prefer planting 6 x 6. In lighter and moderately fertile soils, 4 x 5 feet may be permissible, but such close planting is not generally approved. When

planted in check rows, three or four plants in a hill, the cultivator can be used in both directions. This materially reduces the expense of tillage. In recent years the drill system of planting has become popular in prominent trucking sections. The seeds are usually sown with a drill and the plants thinned to a foot or more apart. This system is probably more favorable to the development of each individual plant; there is less interference of roots as well as vines than when planted in hills, and power sprayers can be used to better advantage.

The young plants are not only tender to frost, but cold winds greatly retard their growth. To overcome this difficulty the rows are sometimes alternated with bush beans. The protection thus afforded to the cucumber is of great value. Another plan is to sow rye in the fall, and in the spring prepare and plant strips of the required width; the remaining areas of rye may be cut and the ground cultivated when the weather becomes warmer and when there is no need of further protection.

440. Cultivation.—Tillage should be continued as late in the season as possible without injury to the vines. The use of broad hoes in the rows and some hand weeding are often necessary to keep the fields clean.

441. Marketing.—Cucumbers for slicing should be not less than 6 inches long when picked and all specimens removed before they begin to turn white or yellow. Picklers are gathered when of the size the grower desires. Gathering is the heaviest expense connected with the crop. The small cucumbers are hard to see and large forces of children cannot be trusted to do the work. The fields are looked over two or three times a week in order to find the picklers before they become too large. When wanted for slicing it is necessary to harvest almost as frequently, to secure uniformity in size and degree of maturity.

Grading is necessary to secure the best returns. **A**

great variety of packages is used in handling this crop. For local markets, upright half-bushel baskets are popular and several forms of crates or boxes are in common use. For shipping, bushel and half barrel hampers (Figure 48) are employed in the large trucking sections of the South. In Texas and perhaps in some other southern states the crop is often loaded in bulk in standard refrigerator cars. A false floor is made of boards and 2 x 4 pieces, plenty of space being allowed between the boards. Another floor is made about midway between the first and the roof of the car, and supported by 2 x 4 posts. Six hundred bushels may be loaded in a car. They generally arrive in the northern markets in first-class condition.

442. Yields and returns.—Yields vary from 100 to 500 bushels an acre, but 200 half-barrel hampers is considered a good crop. Prices range from 50 cents to \$2 a bushel or hamper. The early picklers are sometimes sold on local markets by the dozen, 10 to 25 cents being common prices. A return of \$300 an acre for slicing cucumbers is sometimes obtained, although average receipts are much lower. Picklers produce from three to nine tons an acre, and the price probably averages \$15 a ton.

443. The Striped Cucumber Beetle (*Diabrotica vittata*), the most destructive insect pest of the cucumber, is described by Chittenden as follows: "The beetle measures about 2-5 inch in length. Its color is yellow above, with black head and elytra longitudinally striped. The egg is lemon yellow. The larva is a slender, white, wormlike creature, with brown head, anal and thoracic plate. When mature it measures about 3-10 inch, this being about 10 times its width. The species is indigenous and inhabits the entire eastern United States."

The beetles are particularly destructive to the young plants, but also feed on the old plants as well as on the fruit. The larvæ frequently cause heavy losses by work-

ing on the roots, and the beetles are effective carriers of the dreaded bacterial disease known as "cucurbit wilt."

The beetles appear in April or May, and feed on the young plants as soon as they are up. Egg laying begins promptly and the larvæ feed on the stems, many of them entering when the plants are greatly weakened if not killed. When cold weather approaches, the beetles seek shelter in which to hibernate.



FIG. 82. POWER SPRAYER FOR CUCURBITS

Various plans have been suggested to control this pest. As poisons are not successful, preventive measures are usually employed. Covering the hills with squares of mosquito netting is efficacious, but troublesome and expensive in a large field. If the plants are started under glass and set in the field when four weeks old, the danger of loss will not be so great. Seed should be used liberally, to make allowance for insect depredations. Air-slaked lime is often an excellent repellent when sprinkled on the plants; tobacco dust may be used in the same way.

444. **Diseases.**—Among the diseases of cucumbers, downy mildew, leaf blight and anthracnose are the most important. Bordeaux mixture is the chief fungicide used in combating the diseases of cucumbers. Applications should begin when the plants start to vine and be repeated at intervals of 10 days or less at critical times. Figure 82 shows an effective three-row sprayer.

DANDELION (*Taraxacum officinale*)

445. **Importance.**—The wild dandelion is frequently used as greens, but the leaves are much inferior to those of cultivated varieties, which are larger and often cut or frilled. The most common use of the leaves is for greens, although when blanched with soil they are valuable for salads. The frilled forms make attractive garnishes. The plants are grown in many private gardens and some commercial growers have found small areas very profitable.

446. **Culture.**—A deep, rich soil is required to grow large leaves. It should be prepared as soon as possible in the spring and the seed sown at once in shallow drills a foot or more apart, depending upon the method of cultivation. The plants should be thinned to at least 6 inches in the row, and more space is favorable to large leaves. Several cuttings may be made, but the first is always the finest. Some growers plow and start some other crop after harvesting one lot of leaves. The plants are often held over winter, when very early cuttings may be made the following spring. Top dressings of nitrate of soda are valuable for this crop.

DILL (*Anethum graveolens*)

447. **Culture.**—Dill is one of the many herbs used for flavoring. The seed is especially popular in the flavoring of pickles. It should be sown thinly, about $\frac{1}{2}$ inch deep,

early in the spring in rows a foot or more apart and thinned to 6 or 8 inches.

EGGPLANT (*Solanum melongena*)

448. History and importance.—The eggplant is thought to have been originated in the East Indies, although there is no definite information concerning its early history. It is generally grown in tropical countries, and is an important vegetable in the United States. The southern and south Atlantic states, New Jersey and California, grow large quantities for commercial purposes. In the cooler regions of the North it is often grown in the home gardens, but seldom in commercial plantations. The market demand is increasing.

449. Botany and uses.—The eggplant is an erect, branching, tender annual. The leaves are entire, oblong and grayish-green. The violet-colored flowers are solitary in the axils of the branches, shortly stalked and monopetalous; calyx often spiny, becoming larger as the fruit develops. The fruits are variable in shape, color and size, and are ready to use when one-third grown, continuing to be edible until fully mature. When the seeds begin to harden, the flesh loses its tenderness and delicious qualities. The fruits are usually sliced and fried.

450. Varieties.—There are three distinct colors of eggplants; namely, black, purple and white. Black-fruited varieties find most ready sale; purple-fruited sorts are attractive in appearance, but the smaller size of the specimens is objectionable from the market standpoint; white varieties are seldom seen on the market.

NEW YORK IMPROVED is one of the most popular and largely grown of purple sorts. The fruits are large, well shaped and very attractive.

BLACK BEAUTY is an improvement over the New York

Improved. The fruits ripen about 10 days earlier, are darker in color, and attain a size sufficient to satisfy market requirements.

BLACK PEKIN has been grown commercially for many years, although it is not so popular in recent years as **Black Beauty** and **New York Improved**.

EARLY LONG PURPLE is probably the earliest and hardest of all varieties in cultivation. It is especially adapted to the cooler parts of the North, where the larger varieties do not succeed so well. The fruits are purple and 9 to 10 inches long.

IVORY is a white-fruited variety originated by Dr. B. D. Halstead of the New Jersey Experiment Station. The fruits are beautiful and nearly seedless. The white varieties are much more popular in Europe than in America.

451. Climatic requirements.—On account of its extreme tenderness this vegetable is produced to best advantage in southern sections, because it requires higher temperatures than any other vegetable grown in the United States. Cool nights and short summers are very unfavorable to satisfactory yields. Because of the subtropical character of the plant, special care must be exercised in most sections to secure satisfactory results.

452. Soil.—It is generally conceded that warm sandy soils are best adapted to eggplants. Good crops are seldom grown in clay soils except under the most favorable climatic conditions. It is important that the soil be deep, rich and well drained. A liberal amount of decaying vegetable matter is essential to the largest returns. Southern exposures should have the preference.

453. Source of seed.—Only about 25 per cent of the eggplant seed used in the United States is imported, the seed being grown in the various sections where soil and climatic conditions are satisfactory. The saving of seeds

is a simple matter. The fruits should be allowed to ripen thoroughly on the plants before removing the seeds. Separation and cleaning are readily effected by means of fermentation to loosen the pulp, followed by washing and screening.

454. Starting early plants.—In nearly all parts of the country, glass or other protection is given when starting the plants. In the North, the sowings are always made in greenhouses or hotbeds, while in the South, cloth or glass-covered cold frames are used, especially in starting early plants. The aim should be to grow a strong, stocky, hardened plant ready for the field at the desired time. In the North there are few sections where field planting should occur before June 1. To grow plants of the proper size by this date, the seeds need not be sown before March 10. Many successful growers prefer to sow later than this.

A temperature of not less than 65 degrees should be provided for germination, and from 65 to 75 should be maintained until the plants are set in the open ground. The seedlings require considerably more heat than tomatoes and somewhat more than peppers. If hotbeds are used it is often necessary to make up two beds, one for the germination of the seeds and the other for the care of the plants after they have been pricked from the seed bed. It is difficult to supply an excess of heat either in hotbeds or greenhouses. Too much care cannot be exercised to encourage a steady, unchecked growth. Stunting the plants at any period will cause the hardening of the tissues, resulting in a decreased yield of smaller fruits.

An excellent plan is to make several shifts. The plants may first be set in flats, the seedlings spaced 2 inches apart each way. Later they may be set in 3-inch pots, and finally transferred to 5 or 6-inch pots. When planted in the field there will be no check in growth and the

fruits will ripen considerably earlier than if the plants are kept in flats or beds until planting time. More or less hardening before planting in the field is an advantage. About 120 to 160 days are required to produce a crop of eggplant.

455. Soil preparation.—Manure may be applied heavily for an early crop, like lettuce or radishes, to be followed by eggplants. While this vegetable will stand considerable drouth, there should be no lack of soil moisture if large fruits are desired. Early plowing and frequent harrowing are essential to secure proper conditions for planting.

456. Fertilizing.—Early growth and strong foliage are important. To accomplish these ends nitrogen must be supplied in quickly available forms. The organic sources are also important to meet the later demands of the plants. Before transplanting, the soil should receive not less than half a ton of a high-grade mixture, and just as soon as the plants are established a top-dressing of nitrate. The latter application should be repeated once or twice if necessary, to encourage vigorous growth. Thoroughly decayed stable manure can often be used to good advantage. Some growers apply it in the hill before setting the plants, but this is unnecessary in warm, rich soils.

457. Planting.—Eggplants should never be set in the field until the ground is thoroughly warm. Many growers plant 3 x 4 feet apart, others 4 x 4 and some 2 x 3 feet. The vigor of the variety, climatic adaptability and the fertility of the soil are the main factors to consider when deciding upon distances. Four by 4 feet is not too much space when all conditions are advantageous.

458. Cultivation.—The cultivation of the crop is a simple matter. Moisture conservation is important.

459. Marketing.—As the market demands rather large fruits, eggplants are not usually picked until full grown.

They stand shipment well, but should be handled with care so there will be no bruising. Wrapping in attractive paper containing the name and the address of the grower is an effective means of advertising. The paper gives some protection to the fruits during transportation. The yields are much heavier in the warmer sections where the summers are long. With fairly advantageous conditions two or three specimens to the plant will give a satisfactory return. The development of additional specimens is sometimes prevented by removing the flower buds or blossoms. Such restriction possesses the greatest value where both soil and climate are unfriendly to this extremely tender vegetable. Egg-plants are shipped in barrels, hampers and crates. There should be careful grading in order that the largest profits may be realized.

460. Enemies.—This vegetable has a number of enemies which become sometimes serious. Potato beetles are very fond of the plants. It is often necessary to protect the plants from flea beetles, cut worms and aphides. There are various forms of fungous diseases which may be controlled by spraying with bordeaux mixture.

ENDIVE (*Cichorium Endiva*)

461. Importance.—This plant, which is probably native to East India, is produced more extensively for European than for American markets. It is not generally grown in the home gardens of the United States. In the cities it is consumed mainly by the foreign population, although the general demand is increasing. It is an annual, and, being hardy to frost, it is grown mainly as a late fall or early winter crop and used principally for salad purposes. The cut, curled and frilled leaves are very ornamental when fully blanched and are frequently

used for garnishing, and for flavoring soups; the young, tender leaves are also excellent when cooked as greens.

462. Varieties.—There are two general classes; namely, the curled or fringe-leaved and the broad-leaved varieties. The former is highly ornamental and much more largely grown than the other. Giant Fringed, Green Curled Winter and White Curled are the most popular sorts of the first class. Broad-leaved Batavian is the best representative of the second class, which is used mainly in stews and soups.

463. Soil.—Any rich, moist soil adapted to lettuce will grow a good crop of endive. Rapid growth is important to procure tender, succulent leaves. The plant foods should be quickly available, and nitrate of soda should be used as a top-dressing whenever the plants indicate the need of nitrogen.

464. Planting.—Although grown mainly for fall and early winter markets, an early summer crop may be produced by starting the plants under glass or by sowing in the open as soon as the ground can be prepared. For the fall crop the seed should be sown in July or August, depending upon climatic conditions. The plants require 40 to 50 days to reach marketable size. They make the most satisfactory growth during the cool fall weather. The seedlings may be started in specially prepared beds, and transplanted when of the proper size, or the seed may be sown where the plants are to mature. Whichever method is used 1 foot apart each way provides sufficient space for the full development of the plants. Some growers prefer to thin to only 6 or 8 inches.

465. Blanching.—Unless the leaves are wanted for soups, stews or greens they should be thoroughly blanched. This whitening process is necessary to reduce the bitterness and to render them more tender; it also improves the appearance of the leaves when wanted for garnishing.

Blanching requires 10 to 20 days or longer in cool weather. Any means which will exclude the light from the central leaves and keep the hearts dry to prevent rotting will be effective; the leaves should always be dry when blanching is started. The plants should not be blanched faster than used, because of the danger of the white tender leaves decaying when fully blanched.

The most common method employed is to tie the tops together with raffia or coarse twine. Covering with boards, tile, flower pots (with the drainage holes closed) or other devices will serve the purpose. Soil is also used sometimes, banking as for celery. Leaves or straw may be thrown over the plants late in the fall when it is desired to leave them in the field until the weather is more severe. Many growers lift the plants with some earth clinging to the roots and reset close together in cool cellars, pits or cold frames, shading them when blanching is desired. Endive may be preserved in this manner until midwinter.

GARLIC (*Allium sativum*)

466. Importance.—This perennial, which is native to southern Europe, is a member of the onion family, but is much stronger than the onion in flavor. It is used mainly for flavoring, especially by the foreign population. The sales, however, are very limited in American cities.

467. Culture.—The bulbs are compound, inclosing with a thin, white, membranous covering about 10 bulb-lets, called cloves. Propagation is effected by planting the cloves early in spring or in the fall in mild climates. The soil should be fertile and well drained. Sandy loams are preferred. The cloves are covered with 1 or 2 inches of soil, 4 to 6 inches apart with about 1 foot between rows. The plants die down in the early fall, when the

bulbs may be harvested, cured and stored under the same conditions that are favorable for onions.

HORSE-RADISH (*Cochlearia armoracia*)

468. History and importance.—This garden perennial of the mustard family had its origin in some eastern European country. Later it became naturalized in Great Britain, growing wild along streams, in meadows and in moist, uncultivated soils. In this country it is often seen about the farm premises, generally furnishing roots sufficient to meet the demands of the home, and is largely grown for commercial purposes. It has become one of our most important condiments. The cities use large supplies of the roots during the cooler parts of the year. In most of the trucking regions large fields of it may be seen. Many market gardeners find it a profitable crop.

469. Uses.—The roots are fleshy, whitish externally and pure white within. When properly grown they are long, conical at the top, nearly cylindrical for several inches, and branching below. The flesh is acrid and biting to the taste. When ground or grated it emits a strong, pungent odor. The grated product is treated with vinegar and used mainly as a relish with oysters and meats. The flesh soon loses its stinging properties upon exposure to the air, so that sealing in jars is necessary for its preservation. Horse-radish vinegar is sometimes prepared from the roots.

470. Soil.—Very light soils or heavy clays should not be used for this crop, but deep, fertile, sandy loams provide ideal conditions. A liberal and constant supply of soil moisture is essential to the best results, although good drainage is important. There must be no deficiency in humus if large roots are desired.

471. Propagation.—The plant is propagated from root cuttings made from the laterals removed when the roots

are trimmed or prepared for market. The longest pieces produce the largest roots. They generally range from 4 to 6 inches in length and average about $\frac{1}{4}$ inch in diameter. As these roots are nearly uniform in girth, they are cut square at the top to denote which end is to be planted up; the lower end is always cut obliquely. They should be tied into bundles of convenient size, packed in sand and stored in a cool, moist place until wanted for planting. Some growers prefer to bury in a well-drained soil. Crowns may be planted, but they produce a large number of small, branched roots which are unsatisfactory for grating or grinding.

472. Culture.—Rotten stable manure is often employed in the culture of horse-radish. It should be plowed under rather than used as a top-dressing, because surface applications are thought to encourage branching on the upper portion of the roots. High-grade commercial fertilizers can also be profitably used. The soil preparation should be early, deep and thorough. The roots are generally planted obliquely or perpendicularly, with the tops 3 to 5 inches below the surface, although some growers prefer to place them horizontally. Furrows of the proper depth should first be made if the crop is to be planted alone, and the roots then placed 15 to 18 inches apart, with space enough between rows to operate a horse cultivator. Horse-radish is often used as a companion crop, when the roots may be planted with a spade, dibber or crowbar. (See Chapter XXIII.) Thorough tillage should be given throughout the season. The conditions are most favorable for rapid root growth during the cool weather of early fall.

473. Harvesting and storing.—As the roots are perfectly hardy, they may be left in the ground all winter if desired. Extensive growers dig a portion of the crop late in the fall, burying it in the ground or storing in root cellars or pits until sold. It is customary to harvest

the remainder of the crop as early in the spring as the roots can be dug. When stored, precautions should be taken to prevent the roots from shriveling and drying out.

474. Yields.—The reports on yields and returns vary considerably. Peter Henderson regarded five tons an acre a good average yield, although many growers do not succeed so well. Professor L. H. Bailey states that yields vary from 2 to 4 tons to the acre.

KALE OR BORECOLE (*Brassica oleracea acephala*)

475. History and importance.—Kale is grown extensively near Norfolk, Va., and to some extent on Long Island. Market gardeners occasionally grow small quantities, and sometimes it is seen in home gardens. It is a member of the cabbage family, used mainly in fall and spring as greens. The low, curled varieties are highly ornamental and are valued for garnishing and bedding.

476. Varieties differ greatly in form, size of plants and in character of foliage. The low sorts are hardier than the tall kinds, although all varieties winter without difficulty in southern sections and sometimes in the milder parts of the North. The most prominent varieties are Imperial Long Standing, Dwarf German, Dwarf Curled Scotch and Fall Green Curled Scotch.

477. Soil.—Any soil well adapted to cabbage will, with proper management, produce good kale.

478. Fertilizing.—Stable manures are most valuable for this crop, but high-grade fertilizers are also employed to advantage. Nitrate of soda is especially effective in encouraging a rapid, vigorous growth. It requires the same general treatment as cabbage.

479. Planting.—Sowings should be made early enough in the summer for the plants to attain full size before cold weather. In the Norfolk region the plantings are made from the latter part of June until the middle of

July. Northward, May is not too soon. Kale seed is imported from England and Holland. It is sown in rows spaced to permit horse tillage. The plants are thinned to stand 8 to 15 inches apart according to variety. The seed need not be covered with more than an inch of moist soil.

480. Marketing.—The tender leaves, which are improved by freezing, may be gathered at intervals, or the entire crop cut at one time. They are shipped in light, ventilated barrels or in hampers. Prices vary from 75 cents to \$2 a barrel. Kale is a profitable crop in the Norfolk district.

KOHL-RABI (*Brassica oleracea caulorapa*)

481. Importance.—This vegetable is often called the Turnip-Rooted cabbage. It is closely related to the cabbage and just as easily grown. The stem, which is the edible part, is greatly enlarged immediately above ground. It is not as generally known nor as popular as it should be. When cooked before the flesh becomes woody, it is superior to the turnip in edibility. The early crop is especially delicious.

482. Varieties.—Green Vienna, Earliest Erfurt, White Vienna and Purple Vienna are the leading varieties.

483. Culture.—The early varieties are often forced in cold frames and a much earlier crop may be procured in the open by starting the plants under glass, and transplanting 1½ inches apart each way before setting in the field. Some growers prefer to sow in hotbeds or cold frames, transplanting in the field where the crop is to mature. The plants require the same general treatment as cabbage.

It is customary to space about 8 inches apart in the row and to allow sufficient space between rows for cultivating with either hand wheel hoes or horse cultivators.

Fifteen inches between rows is about as close as plants can be set to permit satisfactory tillage. The seed resembles cabbage seed and should be sown at the same depth. Thorough and frequent tillage is important.

484. Marketing.—It is important to market the crop before the enlargements become woody. The plants may be tied together in bunches like early beets or sold in bulk. Kohl-rabi is a profitable crop whenever a market can be found. This vegetable may be stored in the same manner as root crops.

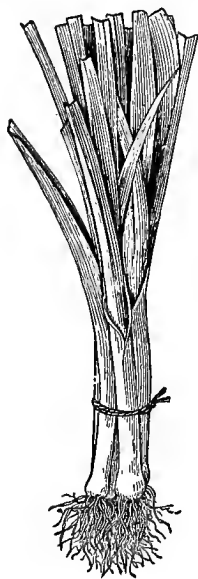

FIG. 83. LEEK

LEEK (*Allium porrum*)

485. Importance.—This member of the onion family produces a sheaf of leaves (Figure 83) rather than a bulb. The sheaf is made up of the lower parts of the flat leaves, is solid and, when well blanched, milder and more tender than the onion. Leeks are generally eaten raw, but are also cooked and used for flavoring. This vegetable is much more popular in some foreign countries, as France, England, Scotland and in southern Europe, than in America, where it is grown mainly for the foreign population.

486. Culture.—Soil and cultural conditions required for onions are equally well adapted to leeks. Rotten stable manures are of great value. The usual plan is to sow in the spring as soon as the ground can be prepared. In June or more often in July the seedlings are transplanted in moist, well-prepared soil. It is an advantage to clip the tops severely at transplanting. The plants may be

set 4 to 6 inches apart, with not less than 12 inches between rows. As the long, white sheaves are the most tender and salable, it is customary to plant the seedlings 4 or 5 inches deep in trenches which are gradually filled as the plants grow, or to set them slightly deeper than they stood in the seed bed and hill as the season advances in order to blanch the sheaves. They are also sold green to some extent. Leeks are readily stored like celery in trenches, cold frames, pits and cool cellars.

LETTUCE (*Lactuca sativa*)

487. History.—This species, which has never been found in the wild state, is thought to be a modification of *Lactuca scariola*, which is indigenous to parts of Europe, Asia and Africa. The Greeks and the Romans used lettuce as a salad, and it is highly probable that the ancients were familiar with its cultivation.

488. Importance.—Lettuce is by far the most important salad crop grown in the United States and Canada. It is a standard vegetable in European countries. Market gardeners in the United States regard it as one of their most profitable crops, and the truck farmers of the South have found it a satisfactory vegetable to grow on a large scale for northern markets. The areas devoted to lettuce are especially large in the Norfolk region and at Sanford, Fla. In recent years lettuce has been produced extensively as a late summer and fall crop in some of the muck soils of the North. As a forcing crop, both in frames and in green houses, it occupies first place in commercial importance. Lettuce may be found on our city markets throughout the year.

489. Varieties.—Prof. W. W. Tracy ("American Varieties of Lettuce," United States Department of Agriculture, Bul. 69, p. 12) presents the following classification and description of the various types: "The classes to be

made of lettuce in the following descriptions are those recognized by most seedsmen and horticultural writers; namely, the *cos*, distinguished by their upright habit, long, loaf-shaped heads, and spatulate leaves; the *butter*, distinguished by their buttery flavor; and the *crisp*, distinguished by their hard, crisp texture. . . . There is no difficulty in identifying the *cos* varieties (Figure 84), but certain of the *crisp* and the *butter* varieties are much alike. The latter are generally more delicately flavored, softer, and more pliable in texture. The *crisp* varieties are coarser veined and larger ribbed than the *butter* sorts, but not more so than the *cos* varieties.



FIG. 84. COS LETTUCE

Their borders are also more developed than other parts of the leaf, and the cotyledons of the young seedlings are generally longer than those of the *butter* sorts. On account of their much-developed borders they are sometimes called frilled lettuce.

“These three classes of lettuce are each again separated into two subclasses. The *cos* are divided into those which are *self-closing*, or comprise kinds which form well-blanching heads without tying up, and the *loose-closing*, or those open sorts, which will not form well-

blanched heads without tying. Express Cos and Paris White Cos are good examples of the first, and Bath Cos of the loose-closing varieties.

“The *butter* and *crisp* classes are separated alike into *cabbage-heading* and *bunching*, the former referring to plants whose leaves overlap one another in such a smooth, regular way as to form a head like a cabbage, and the latter to those whose heads are open, clustered, or bunched in arrangement, or if overlapping one another at all doing so at the heart only, all the outer or visible portions remaining more or less loose leaved. Hanson and Big Boston are good examples of the cabbage-heading varieties, and Early Curled Simpson, Prize Head and Lancaster of the bunching varieties. Under the latter subclass are embraced all degrees of clustered growth from varieties loose-leaved, like an endive, and represented by Boston Curled and Green Fringed, to those densely bunched and represented by Black-Seeded Simpson and White Star.”

In the selection of varieties the following factors should be taken into account:

1. MARKET REQUIREMENTS. Eastern markets prefer head lettuce, although there is an increasing demand for the cos type. For many of the western markets the well-known loose-leaved or bunching variety, Grand Rapids, finds ready sale.

2. SOIL ADAPTATION. It is much less difficult to grow head lettuce in sandy than in heavy soils. Grand Rapids may be grown in all types of heavy soils, and cos is said to be well adapted to clay loams.

3. CLIMATIC CONDITIONS. Some varieties succeed better than others at comparatively high temperatures.

4. THE SEASON. Varieties differ greatly in their power to endure heat and cold.

5. METHOD OF GROWING, whether in the open, the hot bed, the cold frame or the greenhouse.

Eclipse or Express, Dwarf White Heart and Paris White are excellent varieties of the cos type (also known as the Romaine). Hanson, Iceberg, and Brittle Ice are well-known varieties of the solid, "crisp-head" lettuces. The butter varieties are best represented by Dutch Butter, All Seasons, California Cream Butter, and Deacon. Big Boston is grown most largely as a head lettuce in the open ground. Other varieties valued for field planting are May King, All Heart and Sensation. Grand Rapids is the most popular loose-leaved bunching variety grown in the western greenhouses. The various strains of Tennis Ball meet with the greatest favor among eastern greenhouse growers.

There are over 100 distinct varieties of lettuce, which show the widest variation in size, color, solidity, texture, leaf-formation, flower, quality, disease resistance, tenderness to heat or cold and time required to attain maturity. The three best-known and most largely grown varieties in America are Big Boston, Black-Seeded Tennis Ball and Grand Rapids.

490. Climatic requirements.—Lettuce is a cool weather plant. It stands cold much better than heat. The tendency of many varieties is to produce seed shoots prematurely when an attempt is made to grow them in midsummer. The large markets are supplied by various regions which furnish the best conditions as the season advances and by the use of glass and artificial heat during the winter. When properly hardened the young plants will stand even lower temperatures than cabbage plants. A drop of 20 degrees below freezing will cause no injury if the plants have been fully hardened. The matured crop is more easily damaged by severe freezing. Notwithstanding the fact that lettuce is a cool weather plant, it is grown all summer in most parts of the North, due largely to the adaptation of varieties to various climatic conditions. The young plants are wintered

without protection in the Norfolk region; they often pass the winter uninjured on Long Island, especially if covered with a light mulch.

491. Soil.—Warm, sandy soils when properly fertilized are preferable for growing the very early crop; sandy loams furnish the best conditions for all classes of lettuce. Head lettuce never thrives in close, compact soils. For this reason the large plantings, in the open as well as under glass, are usually found on sandy soils. Grand Rapids can be grown in almost any soil properly enriched with stable manures. Big Boston is the best of the heading class for soils and conditions adverse to the best results. Some of the largest and most successful plantations of the North and South are in muck soils. Big Boston is almost invariably selected for these lands.

492. Seed.—Most of the seed used in this country is grown in California. Professor Tracy reports, in the bulletin previously referred to, that 500 acres are planted in California every year for lettuce seed. The annual harvest in that state amounts to 250,000 pounds of seed. From 30 to 60 plants will produce a pound of seed.

The greatest care should be exercised in the production of lettuce seed. Some of the most careful commercial growers produce their own seed from specially selected plants. In many instances this has been the means of developing strains of superior merit.

493. Starting early plants.—The following methods are employed in starting early plants:

(1) Sow in the open ground the latter part of September or earlier in some sections. Transplant in the cold frames in October, and winter like cabbage plants; set in the field early the next spring. This method was formerly employed almost entirely, but it has not been so common in recent years.

(2) Sow in the hotbed or the cold frame 5 to 6 weeks before the ground can be worked in the spring, and set in

the open without previous transplanting. The method is not very satisfactory, because it does not result in the strongest plants, and this necessarily delays maturity.

(3) A popular and satisfactory method is to sow in hotbeds or greenhouses, and to transplant, preferably to flats, which may be kept in cold frames until the plants are set in the open ground. The seed should be sown 8 to 10 weeks before the proper date for field planting, the plants being handled in the same manner as cabbage. If space will permit, it is an advantage to plant 2 x 2 inches apart in the flats rather than closer. To prevent spindling, the seedlings should usually be pricked out in three weeks from sowing. The soil for sowing and transplanting should abound in vegetable matter. Pure muck is probably the best medium, but if this is not available a compost of two parts of good soil, one of sand and one of rotten manure will provide excellent conditions. Mice are very fond of the tender seedlings. They are best guarded against by the use of corn soaked with a solution of strychnine. The plants must be thoroughly hardened before setting in the field if there is danger of hard freezing.

494. Fertilizing.—In the preparation of the soil growers should bear in mind that humus is an important constituent and that stable manures can be used with good effects. They help to secure the proper soil structure as well as to add plant food. Rapid growth is essential to crispness and high quality, and so there must be no want of plant food in available forms. High-grade complete fertilizers should be used at the rate of 1,000 pounds to a ton to the acre, depending upon the previous treatment of the land, and supplemented with dressings of nitrate of soda, which can often be applied at the rate of 150 pounds an acre at intervals of 10 days to two weeks after the plants are well established.

495. Planting.—Soil preparation should be thorough. Plants that have been well hardened may be set in the open ground as early as cabbage. When planted alone, they are usually set 1 foot apart each way, although 14 inches gives a better chance for cultivation. Seed is sown in the open from early spring until late fall, and all winter in the far South. It is customary to drill in rows about 1 foot apart and to thin to a foot or less. (See Figure 85.) In home gardens the plants are often thinned



FIG. 85. HEAD LETTUCE ON THE LEFT. COS LETTUCE ON THE RIGHT

at first to about 4 inches and later to 1 foot. This secures much better lettuce than when the seed is sown in beds, all the plants allowed to grow and the mass of leaves cut when wanted for the table. In the Norfolk region the plants are set 10 x 10 in beds with alleys between. With some protection, as a natural forest or a windbreak of hedges or a tight board fence, the plants usually winter in excellent condition. Lettuce is one of the most popular vegetables for companion cropping. See Chapter XXIII. It is also grown in succession on

the same ground, several crops being marketed during the season.

496. Cultivation.—Wheel hoes and hand hoes are used frequently. When sowing in the open it is important to use land as free as possible from weed seeds, to avoid unnecessary expense in weeding and cultivating.

497. Irrigation.—Few crops are benefited more than lettuce by irrigation. Crispness and high quality are the results of rapid growth, which is dependent upon a large amount of soil moisture. When the plants are provided with plenty of moisture they are not only more tender and of better quality, but they attain a marketable size much sooner, and the land thus becomes available in less time for another crop.

498. Marketing.—The half-barrel hamper (Figure 48, b) is the most popular package for shipping lettuce from the South. On Long Island and in Philadelphia County, Pa., barrels are often used. Various styles and sizes of baskets and crates are used on local markets. Refrigerator cars are utilized in shipping lettuce when weather conditions require their use.

499. Yields and returns.—An acre of lettuce should cut at least 30,000 heads, but a greater number is often produced. Henderson calls attention to a grower who realized a profit of \$1,000 an acre. There are doubtless many small areas near good local markets that do as well. Prices for the shipped product vary greatly from year to year, or at different seasons of the same year. The crop is usually profitable when prices are satisfactory.

500. Enemies.—The enemies are not generally serious. Plant lice, which are troublesome under glass, sometimes cause injury to the field crop. Blights and other fungous diseases appear from time to time, but their attacks are seldom of a serious character.

MARTYNIA (*Martynia proboscidea*)

501. Importance.—This annual is a native of the southwestern United States. The coarse plants have a spreading habit and produce fruit of the peculiar shape shown in Figure 86. The young tender fruits are used to a very limited extent for pickling.

502. Culture.— Sowings are sometimes made in the open, but it is much better to start the plants in hotbeds or greenhouses. They are tender to cold and thrive best in warm soils and sunny exposures. The plants should be set 3 to 4 feet apart each way.



FIG. 86. MARTYNIA

MINT (*Mentha*)

503. Importance.— Peppermint, Spearmint and Japanese Mint are aromatic herbs, grown to a limited extent in American

gardens. Peppermint is used in confectionery and medicine and occasionally for seasoning. Spearmint is popular as a flavoring herb.

504. Culture.—Plants are readily propagated from seed, cuttings or division of roots. In home gardens, the seeds are often sown in beds and the plants allowed to spread at will. Results are more satisfactory by sowing shallowly in drills 12 to 18 inches apart, and thinning to 3 or 4 inches apart in the row. Any moist, fertile garden loam will grow good plants.

MUSKMELON (*Cucumis Melo*)

505. History.—The muskmelon, a native to southern Asia, cultivated by the ancients, has been grown for many centuries in European countries and is now a popular vegetable in many parts of the world.

506. Importance.—Thousands of acres of muskmelons are grown annually in the United States. The acreage is especially large in New Jersey, Maryland, Indiana, Illinois, Georgia, Colorado, Arizona, Virginia and Texas, with extensive areas in many other states. The muskmelon has advanced rapidly in commercial importance during the past 10 years. Enormous quantities are shipped to the great markets and thousands of gardeners supplying local markets find it a profitable crop. The home garden is not complete without it. No vegetable or fruit is more appreciated in its season. With our varied climatic conditions the product is sent to market from early summer until late fall. It is a close rival of the peach for dessert purposes.

507. Botany.—The long, slender, flexible, almost cylindrical stems bear leaves variable in shape and size, although usually kidney-shaped, rounded and often folded or waved on the margins and frequently cut into three to five lobes. While tendrils are supplied, the plants are creeping and do not need support in field culture. The muskmelon has been considered monoecious—distinct male and female flowers produced on the same plant; while investigations made at the Vermont Experiment Station (Vermont Station Bul. 70, p. 18) show that the flowers are generally perfect. In 83 out of 93 varieties examined the pistillate or female blossoms contained stamens and pollen. The remaining 10, consisting entirely of the larger varieties, were monoecious. The fruits are extremely variable in size, shape, color, markings, firmness, texture, color and quality of flesh.

508. Varieties.—The New Hampshire Experiment Station (Technical Bul. No. 2, and also the supplement to this bulletin) has divided American muskmelons into eight groups, as follows:

1. **JENNY LIND TYPE.** "Small size, flattened at the ends, average weight less than $2\frac{3}{4}$ pounds." This class includes Jersey Belle, Emerald Gem, Jenny Lind, Christiana, Shippers' Delight and True Jenny Lind.

2. **ROCKY FORD TYPE.** "Small size, oval shape, average weight less than $2\frac{3}{4}$ pounds." The type includes Rocky Ford, Golden Gem, Paul Rose, Pineapple, Netted Gem, Round Netted Gem and other varieties cataloged since the studies were made at the New Hampshire station. This is very much the most important type commercially.

3. **HACKENSACK TYPE.** "Medium size, flattened at ends, average weight 3 to 6 pounds." Subtype (a) "shallow ribbed, netted," including Ironclad, Early Nutmeg, Chicago Nutmeg and Improved Jenny. Subtype (b) "shallow ribbed, not netted," including Satisfaction, Irondequoit and other varieties. Subtype (c) "deep-ribbed cantaloupes." Belonging to this group are Hackensack, Extra Early Hackensack, Nutmeg, Long Island Beauty, Surprise, Perfection and others.

4. **MONTREAL TYPE.** "Medium size, oval shape, average weight 3 to 6 pounds." Several prominent varieties belong to this class, as Green-Fleshed Osage, Montreal Nutmeg, Tip Top, Miller's Cream and Giant Chicago Market.

5. **COSMOPOLITAN TYPE.** "Medium size, oval shape, no ribs, average weight 3 to 6 pounds." Among the varieties belonging to this type may be mentioned Perfected Delmonico, Blenheim Orange, Cosmopolitan and Superior.

6. **ACME-OSAGE TYPE.** "Medium size, oblong shape, average weight 3 to 6 pounds." Subtype (a) "shallow ribbed," including Netted Nutmeg, Anne Arundel, Honey

Drop, Acme and others. Subtype (b) "shallow ribbed," including Triumph and Lone Star.

7. LONG YELLOW TYPE. "Large size, long shape average weight over 6 pounds." Granite State, Cassaba, Long Yellow and Imported Cantaloupe are the chief varieties.

8. BAY VIEW TYPE. "Large size, oval to oblong shape, average weight over 6 pounds." The varieties are Bay View, Large White French and Large Black Paris.

Many varieties of muskmelons are grown for commercial purposes in the United States, although the shipping trade is limited largely to the Netted Gem or Rocky Ford type. The market demands mainly a small melon of the highest quality; the producer desires a variety which is early, prolific, hardy as possible and disease-resistant. From the standpoint of producer, dealer and consumer it is important for the fruit to hold up well after picking, to stand shipment and retain its good qualities as long as possible. The following are the most important varieties:

ROCKY FORD, decidedly the most important variety grown in the United States, is of the Netted Gem type, oval in shape, about 5 inches long, and, when well grown, of the best flavor. The flesh is light green and of smooth texture. It is grown extensively in many of the great producing districts.

JENNY LIND is a small, round, early melon, popular in some parts of the East. The vines, which are medium in size, are productive.

NETTED GEM. See Rocky Ford.

EMERALD GEM. Fruit of this variety is small, globular, ribbed, lightly netted, dark green; flesh green; quality very good.

JERSEY BELLE resembles Jenny Lind, but is larger and not so early. The fruits are round or oblate and prominently ribbed; flesh green and quality desirable.

MONTREAL (Montreal Market.) Grown largely in Canada for the eastern markets. Fruits very large, green-fleshed and of good quality. They command the highest prices of any melons sold upon our markets.

PAUL ROSE is a cross between Osage and Netted Gem. Fruits small, spherical, ribbed; flesh yellow and sweet.

OSAGE OR MILLER'S CREAM is an excellent midseason variety. Fruit medium in size, flesh deep, yellow and of good quality.

EDEN GEM is grown almost entirely around Salisbury, Maryland. It is prolific and of high quality.

BURRELL GEM is a comparatively new variety, valued in some sections. The flesh is orange color and of high quality.

HACKENSACK and **EARLY HACKENSACK** are green-fleshed varieties of good quality.

Commercial growers of muskmelons should conduct variety tests until they have determined the varieties best suited to their soil, climate and market conditions. The different sorts vary greatly in their adaptation to soils, some succeeding better on heavy soils than others.

The term "cantaloupe" applies to a type of rough, warty, scabby melons grown in Europe but seldom seen in this country. This word is said to have been derived from the name of a village near Rome. The name has no specific meaning in America, for it is given to all types of muskmelons.

509. Climatic requirements.—The muskmelon is much more susceptible to the effects of cold than the cucumber or the squash. It will not stand frost and demands rather high summer temperatures for the most satisfactory results. As a commercial enterprise the crop has been grown most extensively in regions where the seasons are long enough to mature the fruit from seed planted in the open ground. While this is true, hundreds of acres are produced in some sections from plants

raised under glass. The crop should never be started in the open until danger of frost is past. The arid regions of the West, as Colorado, Arizona and New Mexico, produce, under irrigation, melons of excellent quality which command high prices on the eastern markets. While climatic conditions of the West are considered unusually favorable, eastern growers have the advantage by their close proximity to the markets. By allowing their melons to ripen on the vines before marketing, they secure as good quality and are enabled to compete successfully with the West. Irrigation or a liberal rainfall is essential wherever the crop is grown.

510. Soil.—The character of the soil is probably secondary in importance to climatic conditions. Muskmelons may be grown in any soil skillfully handled. Sandy types, however, have the preference because they produce an earlier crop, and are easier to cultivate than heavy ones. It is believed that the quality of the fruit ranges higher when grown on the lighter soils. Nevertheless, clay and silt loams are often used in the culture of this crop and growers who are farming these lands believe their melons are of superior quality. But the largest areas in the United States are on sandy soils.

The structure of the soil is just as important as the texture. When proper additions of vegetable matter are made to clay lands, they often produce excellent results. New land is considered especially desirable. In any soil a constant and fairly liberal amount of moisture is important throughout the season. Drouth or insufficient soil moisture invariably results in a weak vine growth and in small fruits of inferior quality. Thorough drainage is also important. Alkali lands should be avoided, as they are said to produce melons of comparatively low quality.

511. Seed.—Practically all of our muskmelon seed is produced in the United States. Large amounts are

grown in California, Colorado, New Jersey and in some parts of the South.

The importance of high-grade seed cannot be overestimated. Vigor of plant, disease resistance, productiveness, quality and uniformity in all respects depend largely upon the skill in selecting seed. The most approved and scientific methods must be employed if advancement is to be made. There will be little or no progress if simply the best specimens are kept for seed without regard to the character or fruiting qualities of the plant from which they have been taken. The entire plant with its product must be considered as the unit.

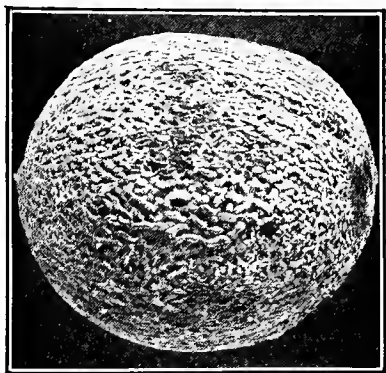

FIG. 87. IDEAL NETTING ON NETTED
GEM MUSKMELON

Hundreds of growers select and save their own seed and the practice is commendable if the work is done with care and intelligence. There is no reason why the growers of any given section should not unite and work together for the improvement of the variety best adapted to local conditions. It would mean greater uniformity in the product marketed and, therefore, higher prices, readier sales and increased demands.

The Indiana Experiment Station suggests the following as the ideal type of the Netted Gem, based partly upon the experience of Colorado growers in selecting Rocky Ford Gems:

Size, slightly less than 5 inches in length and slightly over 4 inches in diameter. This size packs to the best advantage in the standard Rocky Ford crate or "forty-fives." *Seed Cavity* small and well filled with seed. *Flesh* thick, light green in color, shading uniformly to a deeper green from the small seed cavity to the thin rind. *Netting* heavy, well defined and uniform over the whole surface of the melon. A gem of this type will keep longer and ship better than more prominently ribbed types. (See Figure 87.) *Flavor*, rich, smooth and melting. This flavor is usually found in a melon which meets the other requirements mentioned. *Vines* should be strong and prolific and should produce as early ripening a product as possible.

512. Starting early plants.—The general custom is to plant the seed in the field, but as this cannot be done until the ground is thoroughly warm and there is no further danger of frost, many growers have found it profitable to start the plants in hotbeds or greenhouses. There are three distinct advantages in following this method: (1) The melons ripen from a week to 10 days earlier than in open air planting; (2) it makes possible the growing of muskmelons where the summers are short and cool; and (3) it may be the means of avoiding serious trouble from the attacks of insects, particularly those of the striped cucumber beetle.

On the eastern shore of Maryland and in some other southern sections, part of the crop is started under glass. The Canadian crop of the Montreal Market is always started under glass and protected by sash as long as may be necessary. At Decker, Indiana, all of the plants for hundreds of acres are grown in hotbeds until

about four weeks old. In many other parts of the country, glass is used to a greater or less extent in forwarding the plants before it is safe to set them in the field.

It is generally conceded that sowing should not occur more than four weeks before setting in the field, because of the danger of the plants becoming stunted in the frames or the houses or receiving a check when taken to the field. Some growers, however, keep them under glass six weeks, which necessitates at least two shifts in pots and a liberal amount of space.

Paper or earthen pots, berry baskets and veneer boxes are in general use. Some growers also plant on inverted sods or in hills in flats, and block out the soil around the plants with a sharp butcher knife when planting in the field.

The Montreal melons are sown in any convenient seed bed, and the young seedlings set in 3 or 4-inch pots, and shifted to larger pots for the early crop, the seed for which is sown earlier than when only one shift is made.

The Indiana Experiment Station (Ind. Sta. Bul. 123, p. 6) gives the following description of the method employed at Decker: "The beds are substantially built of 2 x 8 planking and are 9 feet wide and from 25 to 40 feet long. Many of them hold 2,000 to 3,000 young plants, or enough to set out nearly two acres. A single grower frequently has a range of 30 to 40 of these hotbeds, enabling him to set from 50 to 75 acres of cantaloupes. The beds are usually placed in a warm and sheltered situation, so as to get the full benefit of the early spring sun. The seed is started during the last week of March or the first of April in small veneer boxes. These are about 5 inches square and are similar to berry boxes, except that the bottoms are flush instead of recessed. They are placed side by side in the bottom of a hotbed and filled with finely prepared earth and compost. Great care is taken with the material for the seed bed, and it is very thoroughly worked over before being used.

"The soil is made firm and allowed to come slightly above the top of the boxes in the hotbed. It is then marked out in squares in such a way that the intersection of the marks center the boxes. The seed bed is now ready. After putting in the seed, careful attention is given to watering, to ventilation and to keeping out weeds. A day temperature is maintained at first of 50 to 60 degrees. As the time for transplanting draws near

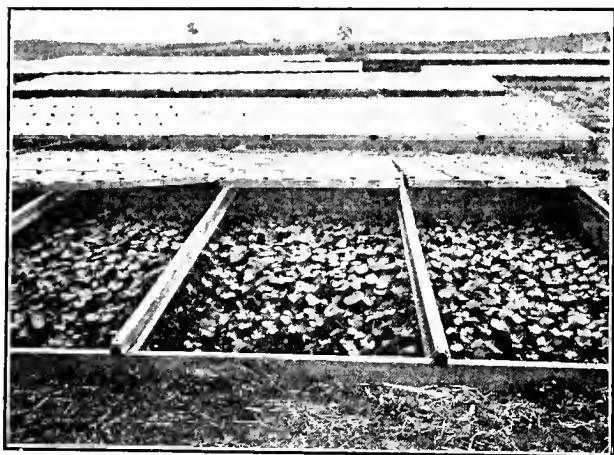

FIG. 88. STARTING MUSKMELONS IN FRAMES

more air is given in order to harden off the young plants. The seedlings are moved about in the beds to fill possible vacancies, and by the time they are ready to transplant a perfect stand has been secured with one plant in a hill. (Figure 88.)

"Several plans for watering are in successful use. A common method is to mount a tank on trucks and drive along the hotbeds, watering through a lead of hose, provided with a rosette. Some growers, whose beds are

near their windmills, have pipe lines laid among their beds with hydrants conveniently located for watering with the hose, the pressure being supplied by a tank in the windmill tower."

Whether starting in hotbeds or in greenhouses, fresh air should be admitted daily to secure strong, healthy plants. There is much less trouble from damping off fungi when this matter is given proper attention.

513. Soil preparation.—Land which has been previously cropped with red clover, alfalfa, cowpeas or crimson clover is regarded excellent for muskmelons. Soil that has been highly manured for other truck crops the previous year is well suited to this vegetable, provided other conditions are satisfactory. Early spring preparation is essential. The plowing should be as deep as for any other crop, and the land should be harrowed at proper intervals until time to plant.

514. Fertilizing. — In fertilizing, the muskmelon grower should keep four facts in mind, viz., (1) that this plant thrives best in soils containing a liberal proportion of vegetable matter; (2) that soils excessively rich in nitrogen are likely to cause a rank growth of vine and a small and inferior crop of melons; (3) that rapid growth is important early in the season; (4) that the mineral elements are essential to large yields and high quality.

Stable manures are unquestionably the most effective materials to use in growing muskmelons. They should be thoroughly composted before applying. As indicated for cucumbers, various kinds of stable manures may be applied broadcast, in the hills, or in furrows previous to planting. In most instances, profits are increased by supplementing with commercial fertilizers. When clover sods or leguminous crops are plowed down, splendid results can be obtained from fertilizers alone, using more nitrogen than when stable manures are employed. A

4-8-10 fertilizer probably meets the requirements of most soils as satisfactorily as any mixture that can be used, although there might be some advantage in reducing the percentage of potash and increasing the phosphoric acid. One thousand pounds of this fertilizer applied before planting is sufficient in most cases. Some growers prefer to use about half of the allowance to the acre a week or more before planting and the balance after the crop is well started; others apply all of the general mixture before planting, supplementing later with top-dressings of nitrate of soda if the growth indicates the need of more nitrogen.

Numerous and comprehensive experiments were made in Georgia (Ga. Sta. Bul. 57, pp. 163-175), the station making the following recommendation: For South Georgia, 1,000 pounds acid phosphate (14 per cent), 250 pounds muriate of potash and 1,000 pounds cottonseed meal. This formula will analyze 3 per cent of nitrogen, 8 per cent of phosphoric acid and 7 per cent of potash. For Middle and North Georgia: 1,300 pounds acid phosphate (14 per cent), 200 pounds muriate of potash and 1,000 pounds of cottonseed meal, which formula will analyze about 2.8 per cent of nitrogen, 8 per cent phosphoric acid, 5 per cent potash. The station recommends from 600 to 800 pounds an acre.

In northern as well as southern sections of the United States, part of the nitrogen should be derived from nitrate so as to hasten growth immediately after planting. The thinner the soil the greater the necessity for using large amounts of nitrogen.

515. Planting.—As previously stated, neither plants nor seeds should be risked in the field until the ground is thoroughly warm and there is no danger of frost. When the plants have been started under glass they must be shifted to the field in the most careful manner so that roots and soil about them will not be disturbed. When

this is accomplished there will be little if any check in growth. If the plants are watered freely 5 to 10 hours before transplanting, the soil will hold together better during the transfer. The corners of berry baskets and dirt bands or cubes should be cut out with sharp knives at the hills in the field. In removing the plants from pots, one hand should be placed over the pot with the stems of the plants between the fingers, and the pot then inverted and tapped gently to separate soil and roots from the sides of the pot. When planting in the field the soil is simply drawn to the balls, cubes or blocks of earth, downward pressure being avoided because this would disturb the roots.

Muskmelons are planted in both hills and drills. The hill system makes it possible to cultivate more thoroughly and is the more popular in many of the largest producing sections. Drilling, however, is favored by many of the best growers, and doubtless provides the most perfect conditions to each individual plant, because they are not competing with each other in the struggle for food, moisture and sunshine.

When in hills, the spacing distance is commonly 6 x 6 feet, while some prefer 5 x 7, others 4 x 6, $4\frac{1}{2}$ x $6\frac{1}{2}$ or 5 x 7 feet. When in drills the plants may be from 1 to 2 feet apart. The space between rows is seldom less than 6 feet. Manure and fertilizers are often mixed in hills or furrows before planting, while some growers always apply broadcast. The depth of covering varies from 1 to 2 inches, depending upon the character of the soil. It is best to use plenty of seed, 10 to 15 to the hill, in order to be certain of a good stand. From 1 to 3 pounds of seed are required to the acre. Some growers make two or three plantings in the hill or the furrow at intervals of a few days, to insure a good stand. Frost may injure or destroy the first lot, but the later plantings will escape.

Thinning should not be done until the plants are well started. The tendency is to allow fewer plants to the hill than formerly. It is doubtful whether more than two plants should ever be left. Crowding always decreases the size of the melons. An experiment made in Georgia (Ga. Sta. Bul. 57, p. 177) shows the importance of severe thinning. The results were as follows:

	Marketable	Average weight per melon lbs.	Unmarketable
Plat A, one plant to the hill.....	90	1.09	19
Plat B, two plants to the hill.....	116	.98	30
Plat C, three plants to the hill.....	86	.99	27
Plat D, four plants to the hill.....	47	.79	57

One plant to the hill, it will be observed, yielded the largest melons and the smallest percentage of unmarketable fruit. Two plants to the hill gave more marketable melons, but there was no real gain, as the melons were smaller and there was a larger percentage of unmarketable fruit. Three and four plants to the hill gave fewer marketable melons and a larger percentage of unmarketable fruit; the marketable melons were also smaller than in plats thinned to one plant to the hill.

Forcing boxes have been profitably used in some sections. They are especially popular in New Mexico, but probably possess even more merit in northern sections. The New Mexico station (New Mexico Station Bul. 63, p. 27) gives the following account of their construction and management: "These boxes may be made from inch lumber, 8 x 10 x 12-inch, with a groove for a 10 x 12-inch glass. The cantaloupe seed is planted in the field as early as possible in the spring and the glass-covered boxes are placed over the hills; at the station the seed has been planted as early as March 25.

"The seed soon germinates and the plants grow right along without being injured by the low night temperature. If it can be so arranged, it is desirable to have

the boxes sloping slightly to the south and the east. After the plants have come up care should be taken in ventilating. The general practice of some growers is to remove the box in the forenoon, and in the afternoon to replace it. Others simply pull the glass out a few inches. The latter method seems to be better, for the reason that the plant gets plenty of air and at the same time is protected from the cool and hard winds that are likely to blow during the day. The boxes are removed after all danger of frost is over. The plants should be hardened before the boxes are removed."

516. Cultivation.—Cultivation must be shallow, frequent and thorough. The ground should not be allowed to bake as long as it is possible to get between the rows with a cultivator. Many growers shift the vines when they attain considerable size, and continue tillage until the crop is well advanced. More or less hand hoeing is necessary during the entire period of growth.

517. Marketing.—The time of picking depends mainly upon the distance from market. If to be sold locally, the melons should be allowed to ripen fully on the vine. When for distant shipment, the usual plan is to pick the fruit when it will separate readily from the stem, which should be left attached to the vine. Cracking about the stem on the Gem type of melons indicates that ripening is in progress and that the fruit will part readily from the vine. While melons are often pulled before they have reached this point, it is always done at the sacrifice of quality. Considerable experience is required to decide just when each melon is ready for market, especially if an attempt is made to pick them before they have changed to the characteristic gray color desired by all markets. To secure uniformity of ripeness the plantation should be picked over every day.

A great many growers do not grade their melons.

This is just as serious a mistake as the failure to grade apples before marketing. The extra care assists dealers in meeting the demand from different classes of trade and increases profits for the producer. It is necessary to make three grades, except toward the close of the season, when two will serve better. The three grades are variously designated. In Illinois they are termed, fancy, No. 1 and No. 2, besides culls. The Illinois Experiment Station (Ill. Sta. Bul. 124, p. 303) gives the following information in regard to this important matter:

“The quality is the primary factor which determines the grade of a melon, though size and condition are also to be considered. Extremely high quality and uniformity in size and condition are essential in the making of a fancy grade. The size must also be normal and the packing perfect. The No. 1 grade should be of nearly as high quality as the fancy grade, but may include odd sizes, though the different specimens in a given package should be fairly uniform in size. This grade may include melons too large or too small for the fancy grade. The No. 2 grade should consist of the balance of the salable melons. These should be of fair quality and far superior to the flavorless culls sometimes shipped by unscrupulous growers.

“There is a close relation between the amount and character of netting and the quality of a melon, so that, after a little experience, it is possible to grade melons with extreme accuracy as to quality, on the basis of netting. As a rule, the denser and more fully developed the netting, the better the quality of the melon. The netting should stand out like whip cords on melons graded as fancy stock. Well-netted melons, in which the netting is not quite so prominent, together with off sizes of the best-netted melons, may be graded as No. 1. Specimens with still less netting, but in which the netting is fairly well developed, may be graded as

No. 2. The extent to which the netting is developed is more important than the absolute amount of netting in determining whether a given specimen shall be graded as a No. 2 or a cull. Melons in which the netting is very poorly developed, as well as those without any netting, should be classed as culls. Cracked and overripe specimens must be graded as culls, even though of fine quality, for they would be likely to spoil before reaching the consumer."

A great variety of styles and sizes of packages is used in marketing muskmelons. Figure 49, c, illustrates the



FIG. 89. MUSKMELONS PACKED IN CLIMAX BASKETS

standard crate, which holds 45 melons, and is used by growers in Colorado and many other states. One of the best packs is the climax basket (Figure 89.) The dimensions of this basket used in Illinois (Ill. Sta. Bul. 124, p. 306) are as follows: Width of bottom, 6 inches; length of bottom, $16\frac{1}{2}$ inches; width of top, packed, $7\frac{1}{2}$ to $8\frac{1}{2}$ inches; length of top, $18\frac{1}{2}$ inches; depth (not including cover), $6\frac{1}{4}$ inches.

Smaller sizes of crates than the standard size are

sometimes used. Bushel and half-bushel baskets are also popular in some sections for local sales. In all types of packages, the melons should be packed firmly, so they will not bruise or be injured in transit.

518. Yields.—Nearly 345 standard crates of muskmelons an acre were produced at the Arizona station. It is not unusual for growers to harvest over 200 crates to the acre. In New Jersey 150 crates an acre is regarded a good yield, and 100 crates is considered a satisfactory crop in Georgia.

519. Insect enemies.—The striped cucumber beetle is one of the most destructive insect pests. (See Cucumbers.) The melon louse is a serious enemy in some seasons. Infested plants should be destroyed as soon as discovered. The usual insecticides for aphides may also be employed, but the spraying of a field of melons when the plants have attained considerable size is not easy to accomplish. It is doubly difficult to kill the lice, because they feed on the underside of the leaves.

520. Diseases.—Bacterial wilt (*Bacillus tracheiphilus*) may appear at any time during the season. The disease is dreaded because no means has been discovered to combat it successfully. It spreads sometimes rapidly, while at other times the infection is very slow. Wilting is caused by the germs of the disease filling up the water ducts, and preventing circulation in the plants.

Rust or blight annually causes heavy losses in various parts of the country. It is most likely to be destructive in warm, showery weather at low altitudes and where there is little circulation of the air. The disease may be controlled by spraying with bordeaux mixture. The first application should be made when the plants begin to vine, with subsequent treatments to keep the plants well armored against the disease spores.

521. The Montreal melons.—It is believed that the Montreal muskmelons could be grown in various parts

of the country were the proper care exercised in their culture. The Vermont Experiment Station (Vt. Sta. Rpt. 1907, p. 358, Bul. 136) has furnished the instructions contained in the following synopsis (Experiment Station Work, Vol. III, No. 9, p. 236):

The seed is sown in greenhouse or hotbed from late February to early April; later the plants are potted in 3 or 4-inch pots, and when in danger of suffering for lack of root space and plant food and the weather is favorable they are removed to sash-covered frames, there to remain until almost fully grown. These hotbeds are well constructed, well exposed to the sun, and also protected from cold winds. The frames are often covered with two sets of sash, mats, and board shutters. With such protection, if horse manure is used to generate a sufficient bottom heat and the exposed portions of the frames are banked therewith, the plants may be grown almost as well as in a greenhouse. These frames are movable sections, approximately 12 by 6, strong and tight with tie rails for the sash to slide upon.

The soil over which these sections are set is ridged up in beds 12 to 16 feet wide with a 1-foot center elevation. A trench is dug 2 feet wide, 15 to 18 inches deep, and filled almost level with well-fermented manure, and a portion of the surface soil thrown over it, slightly more being drawn in where the plants are to be set. The frames are then set in place and covered with sash, which in turn are further reinforced with mats and wooden shutters, or hay or straw with or without the shutters. A 4 to 6 foot space is allowed between the ends of each section. When the soil over the manure is well warmed up, the warmest portion of some favorable day is selected for planting. Great care is exercised now in transferring the plants from the hotbeds to guard against setbacks from sudden changes of temperature or soil conditions. The coddling process does not cease

now. It is simply spread over a greater area and the plants require even closer care than before, for greater attention must be paid to watering, syringing, and ventilation, success at this stage being very largely dependent thereon.

As the fruit attains size, it is usually lifted from the soil by a shingle or a flat stone, to avoid loss from cracking, rot, etc. Uniform shape, color, netting and ripening are secured by turning the fruit every few days. When the runners fairly occupy the inclosed area the frames are raised a few inches. As the season advances more and more air is admitted until, finally, when the melons are almost full grown, the sash and then the frames themselves are removed.

As each fruit sets, its shoot is pinched off one or two joints beyond it. A 15 to 20-melon crop is considered sufficient from each 6 to 12-frame. Three or four hills are planted and usually two plants are set in a hill.

The melons vary greatly in size. One weighing 44 pounds has been grown. Their average weight ranges from 8 to 15 pounds, and a dozen average 120 to 130 pounds. In exceptional cases some have been shipped weighing 240 pounds a dozen-package. The larger melons are apt to be poorer in quality than those weighing 8 to 15 pounds.

Two distinct types exist, a roundish oblate and an oblong, the first slightly deeper ribbed than the latter. These do not seem to be separated by the growers. It is not at all certain that either type is fixed.

A large wicker basket (clothes basket) is commonly employed in shipping to distant markets. It holds a dozen melons, packed in short, fine-stemmed hay, and is shipped without cover, no attempt being made to fasten the melons in place. The express company is held responsible for safe delivery.

MUSTARD (*Brassica*)

522. Importance.—Mustard is a member of the cabbage family. It is used as a salad plant, often with cress, and also for greens. The seeds are used in the manufacture of the mustard of commerce. This plant is often grown in home gardens and to a limited extent for commercial purposes.

523. Culture.—In the North the seed may be sown at any time from early spring until fall to obtain a succession of young tender leaves. It is customary to sow as soon as possible in the spring for the early summer crop, in July or August for the fall crop and in September for the spring crop. Southward it is often started in the fall, for cutting early in the spring. The sowings are made in drills a foot or more apart, and then thinned to 5 or 6 inches in the row. White London is perhaps the best variety for the North; Southern Giant Curled is popular in the South. Chinese is a broad-leaved variety, producing a large amount of herbage.

OKRA OR GUMBO (*Hibiscus esculentus*)

524. Importance.—This hot weather perennial is grown to a considerable extent in the South, and in a limited way in the North. The young, tender pods are used mainly in soups and stews, although they are excellent when boiled and served hot or cold as a salad.

525. Culture.—In the South the sowings are made in the open ground; in the North the plants should be started under glass, the seed sowed in pots, inverted sods or in other devices, so the shift to the field may be made without disturbing the roots. The planting distances depend upon the vigor of the varieties, but ordinarily 2 x 3 feet apart provides sufficient space. The soil should be warm and fertile. Several varieties are in

cultivation. For a detailed discussion on the culture and uses of this crop, see Farmers' Bulletin No. 232.

ONION (*Allium cepa*)

526. History.—The onion has been grown since remote antiquity. The oldest historic records frequently refer to its culture and its use as an article of food. It probably originated in the southern part of Europe or in countries bordering on the Mediterranean Sea. A great variety of types has been developed. The most marked progress in the breeding of the modern globular bulb has been made within the last 25 years.

527. Botany.—The onion belongs to the lily family, which also includes the asparagus. It is generally a biennial, although some forms, as the multipliers, are perennial. Usually it is grown as an annual for the bulbs, and sometimes for the tops, which are used in seasoning. True stems are not produced. The portion above the bulb is often as valuable for food as the bulb itself. The bulbs are variable in color, being white, yellow, red and intermediate shades of these colors. The seed stalks are long, slender and hollow. They bear dense, showy, round heads of small white or lilac-colored flowers. Instead of producing flowers, some forms, as "tree" and "top onions," produce clusters of sets or bulblets which are planted to produce bunching onions or mature bulbs. The seeds are black, angular and flattened.

528. Importance.—This is one of the most important vegetables in the world, being grown in nearly all countries and ranking third in commercial importance in the United States. (U. S. D. A. Farmers' Bulletin 354, p. 5). Fourteen million bushels, valued at \$10,000,000, were grown in this country in 1908. The annual importations from Spain, Egypt, Bermuda and the South Sea Islands amount to about 1,400,000 bushels. Its wide

adaptation to different soils and climatic conditions and its general use the year round for culinary purposes properly give it a place among our most useful vegetables. It is universally planted in the home garden and the commercial areas occupy thousands of acres. The crop offers special inducements for the employment of intensive methods, as the possibilities of profit are greater than for most classes of vegetables.

529. Varieties.—In the selection of varieties the following factors should be considered: (1) Time of maturity. Earliness is often an important matter. (2) The size of the bulb. (3) Color of the bulb. The eastern markets prefer yellow and white onions, although a considerable quantity of red onions is grown and sold in the East. Red onions sell best in the Middle West. (4) The shape of the bulb. Globular-shaped onions are preferred on all markets. (5) The quality of the bulbs. The foreign types are known to be milder and more tender than the domestic sorts. (6) Keeping qualities. American onions keep much better than the foreign types. (7) Soil adaptation. (U. S. D. A. Farmers' Bulletin 354, p. 29.) Yellow and red onions are especially well adapted to muck soils. Red and brown varieties thrive on prairie soils, and all classes do well on sandy loams and light soils. Bermuda, Spanish, and Egyptian types flourish on the deep, rich alluvial soils. (8) The yielding power. Some varieties produce many more bushels an acre than others. (9) Climatic adaptation. (10) Shipping qualities, or the degree of injury or damage sustained from bruises. (11) Purpose for which the onions are grown, whether for large bulbs, pickling or bunching.

AMERICAN VARIETIES

DANVERS (Danvers Yellow, Round Yellow Danvers, Yellow Globe Danvers) is the most largely grown of the

yellow onions. It is produced extensively in nearly all regions where the crop is grown from seed sown in the open ground. The bulbs are solid and of good form, although not so distinctly globular as some other varieties. Danvers is an old sort that has been very popular for many years.

SOUTHPORT YELLOW GLOBE is grown to a great extent in many sections. The bulbs are larger and more globular in form than Danvers. It is an attractive sort and a good keeper.

STRASBURG (Philadelphia Yellow Dutch) produces a somewhat flattened bulb. The variety is widely grown for sets.

WEATHERSFIELD has long been a popular red onion, and is valued for shipment to distant markets.

SOUTHPORT RED GLOBE is a general favorite wherever red onions are grown from seed sown in the open ground.

SILVER SKIN (White Portugal) is a well-known white variety grown extensively for sets.

SOUTHPORT WHITE GLOBE produces a large globular bulb from seed sown in field or garden.

SILVER KING is an excellent variety for sowing in the open. The bulbs are large and possess good keeping qualities.

WHITE PEARL is a very early variety. Bulbs are medium sized, mild, pure white and very attractive. They do not keep well, but are valuable for the early market.

WHITE QUEEN, an extremely early onion, produces small, pure white, very mild bulbs, largely used for pickling.

EARLY RED is valued as a red, early-maturing variety.

WHITE BARLETTA is an extra early white onion, which keeps well and is excellent for pickling.

WHITE AND YELLOW MULTIPLIERS (potato onions) are planted extensively for bunching. (544.)

THE EGYPTIAN (Perennial Tree Onion) is a perfectly hardy variety of medium quality, valued for fall planting in the North to produce early spring bunching onions. (544.)

FOREIGN TYPES

The bulbs of Bermuda, Spanish and Italian onions are much larger than those of the American class. They also require a longer season to mature and are not so hardy. The flesh is more tender, and milder, but the bulbs do not keep as well as those of American onions. They are nearly always started under glass in this country, even in southern districts.

PRIZETAKER seed was first grown in California from a shipment of Spanish bulbs. The variety has become very popular in the United States, especially for the transplanting system of culture. The bulbs are very large, often weighing more than a pound; bright yellow, thin skin; flesh white, fine-grained, mild, with a delicate flavor. They possess only fair keeping qualities.

WHITE ITALIAN TRIPOLI produces very large, white, flattened bulbs.

GIGANTIC GIBRALTAR and **DENIA** produce bulbs similar to those of the Prizetaker, but require more time to mature. They are also milder in flavor.

RED BERMUDA, **WHITE BERMUDA** and **CRYSTAL WAX** are the leading varieties of Bermuda onions.

530. Climatic requirements.—Fortunately, it is possible to select varieties suitable to a wide range of climatic conditions. The most tender sorts of the foreign types, as the Bermuda onions, thrive in some parts of Texas, Florida and Southern California, and do well at the North when started under glass. They often, too, produce excellent crops when sown in the open, under the most favorable conditions. All the American varieties

thrive in the northern states, and with proper culture generally do well in the South. The multipliers or potato onions are thoroughly at home throughout the South, and with some winter protection may be grown for early bunching in the North. The Egyptian or Perennial Tree onion is hardy in the North, even without protection.

While this vegetable may be grown successfully under a wide range of climatic conditions, it succeeds best in temperate regions without great extremes of heat and cold. When grown in the far South, as in Texas, advantage is taken of fall and winter. The crop is planted in September and harvested in March and April. From 130 to 150 days are required to mature bulbs of the various varieties. A bountiful supply of soil moisture is necessary early in the season, when the plants make very rapid growth. A dry soil and low humidity are important for ripening, harvesting and curing the bulbs.

531. Soil.—Land to be used in growing onions should be practically level to prevent damage from washing. The seeds, sets, or young, shallow-rooted plants are easily washed out on sloping lands. The soil should be retentive of moisture and yet well drained, friable, easily worked, fertile and free from stones and rubbish which would interfere with the proper use of drills, hand and wheel hoes.

Vast areas of muck and peat soils are devoted to the culture of onions. The crop is doubtless grown at less expense in these soils, which abound in vegetable matter, than in other types requiring more manure and fertilizer and a greater expenditure of labor. Their dark color causes them to warm up rapidly in the spring, and thus they favor early planting, which is universally regarded as important. These soils, rich in organic remains, retain moisture, so that drouth seldom curtails the crop to any great extent.

Sandy loams, when properly enriched with humus and plant food, furnish excellent conditions for onions. They are easily worked and produce solid, heavy bulbs of superior keeping quality.

Clay soils should be avoided. They become too hard and compact for best results. Clay and alluvial loams, when properly handled, yield profitable crops, but the supply of humus must be liberal to prevent serious baking. Incrustation is especially damaging when it occurs before the plants are up or large enough to permit thorough tillage.

532. Seed.—Inferior seed is the source of heavy and frequent losses in onion culture. Onion seed must be fresh, never more than a year old and produced from bulbs of a superior character. Some seed firms have established reputations for selling high-grade seed of this vegetable, and growers should exercise extreme care in ascertaining the best sources of supply.

While it is less difficult at present to procure good seed than formerly, a large number of gardeners and onion specialists raise their own seed. The bulbs are best selected at harvest. They should be of the desired size and form. A short neck is considered an advantage. Uniformity in all of the essential characteristics is exceedingly important in choosing bulbs for seed purposes. Seed bulbs should be stored as directed in this chapter (541) and planted as early as possible in the spring. (Some growers prefer fall planting.) The ground should be only moderately fertile, especially in nitrogen. Furrows are made 4 or 5 inches deep and 14 to 30 inches apart, depending upon the method of cultivation. After placing the bulbs about 6 inches apart in the bottom of the furrow, they are covered with a hoe or a small plow. The long, slender seed stalks should have some support, which may be provided in two ways: (1) By ridging with soil to the height of 7

or 8 inches, the usual plan, and (2) by driving stakes at the ends of the rows and at frequent intervals and then stretching cheap twine on either side. When mature or ripe the heads turn yellow. At this stage they should be removed promptly with 6 to 8 inches of the stalk before any seed is lost. As the tops do not ripen at the same time, it is necessary to make several cuttings to prevent loss. A tight vessel, or basket with a cloth lining, should be used in collecting the seed. The tops are spread in an airy room with a tight floor until dry enough to separate with a flail or by other means. Winnowing will remove most of the chaff. The seeds may then be placed, a few pounds at a time, in a vessel of water. The heavy seeds, which sink, are saved, while the light ones and the remaining chaff are poured off. After thorough drying and curing, the seeds may be stored in any dry room.

533. Soil preparation.—The method of soil preparation will depend mainly upon the character of the soil, and the crops previously grown. Fall plowing is often an advantage, especially for pastures, heavy sods, muck lands and clay loams. A favorite practice before planting any field in onions for the first time is to grow the previous year a crop, such as potatoes or corn, which requires thorough cultivation. Coarse stable manures may also be used the year before planting onions. Such a course of treatment will rid the land of troublesome weeds and increase the supply of humus. Rotation is highly desirable, as it is a means of reducing loss from fungous diseases and insect pests and of maintaining proper soil conditions. Other vegetables, as spinach, celery, beans, lettuce, etc., may be used with profit. The selection of the other crops in the rotation must be determined by market, soil, moisture, climate and labor conditions.

Whatever crops are grown previous to planting on-

ions, the soil preparation must be thorough. If plowing is deferred until spring, this operation should be attended to as soon as the ground is sufficiently dry, followed by repeated harrowing, to prevent the escape of soil moisture and to prepare a fine seed bed. The usual forms of disk harrows, followed with the Meeker Disk Smoothing Harrow and finished with a plank drag should leave the land fine, even and smooth.

Muck soils, to be used for the first time, require special preparation. They must be cleared, drained and thrown up to the exposure of winter freezing. Although analyzing high in plant foods (401), large amounts are not available. Lime will help to release the needed plant food and to correct any soil acidity that may exist. It is generally desirable to grow other crops for a season or more until proper soil conditions have been secured.

534. Fertilizing.—An analysis of the Southport White Globe onion shows that 2,000 pounds of the mature bulbs contain 2.70 pounds of nitrogen, 0.92 pounds of phosphoric acid and 2.09 pounds of potash. The average legal weight of a bushel in the United States is about 56 pounds. A yield of 500 bushels an acre would, therefore, make a total of 28,000 pounds, and would require 37.80 pounds of nitrogen, 12.88 pounds of phosphoric acid and 29.26 pounds of potash. Although these figures have some value in indicating the needs of the onion, it is generally recognized that the amounts of the elements used should be considerably in excess of those shown by chemical analysis. The fact is, that no other vegetable requires higher fertility than the onion. The plants must have a bountiful supply of available food until the bulbs are formed.

Stable manures are universally preferred to commercial fertilizers because of their influence on the physical properties of the soil. Poultry droppings, on account

of their fineness and high percentage of nitrogen, possess the greatest value. When gardeners keep large flocks of chickens it will pay to collect the droppings— at regular intervals and to preserve them so that there will be a minimum loss of nitrogen. All manures, however, are prized for this crop. Composting the coarser manures is regarded as essential to reduce them to the proper physical condition, to prevent excessive top growth at the sacrifice of bulb formation and to destroy weed seeds. Fresh manures may be applied to other crops the year before or spread in the fall before or after plowing. An excellent plan is to plow first and then apply and disk in the manure. Rotten or composted manure is used to the best advantage in the spring after plowing, thoroughly incorporating with the soil before sowing or planting the onion crop.

Hundreds of successful growers cultivating lands remote from supplies of manure must resort to the use of commercial fertilizers. The greatest differences prevail in regard to formulas and amounts used to the acre. Voorhees ("Fertilizers," p. 280) recommends, for sets, "50 pounds to the acre of nitrogen in organic forms, as dried blood, cottonseed meal or tankage; 60 of phosphoric acid, which may be partly in organic forms, as bone or tankage; and 100 of actual potash, derived from a muriate. The application of a fertilizer containing nitrogen 5 per cent, phosphoric acid 6 per cent and potash 10 per cent, at the rate of 1,000 pounds an acre, and well worked into the soil previous to planting, would furnish these amounts." He further recommends applications of nitrate of soda or sulphate of ammonia at intervals of about three weeks. The fertilizers usually employed range from 4 to 6 per cent of nitrogen, 5 to 8 per cent of phosphoric acid and 8 to 10 per cent of potash.

For use in southern states, Beattie (U. S. D. A. Farmers' Bulletin 354, p. 13) recommends:

	Pounds
Nitrate of soda, 14 to 16 per cent nitrogen.....	2,000
Cottonseed meal	750
Acid phosphate, 16 per cent.....	750
Muriate of potash, 50 per cent	300
	<hr/>
Total	2,000

For use in sections where cottonseed meal cannot readily be obtained:

	Pounds
Nitrate of soda, 14 to 16 per cent nitrogen.....	300
Dried blood	500
Acid phosphate	800
Muriate of potash, 50 per cent	400
	<hr/>
Total	2,000

When early maturity of large bulbs or bunching onions is desired, nitrate of soda should be used more freely. It is in general use among onion growers, the amount for dressing varying from 50 to 200 pounds an acre. The early applications are most valuable.

The total amount of commercial fertilizer an acre has a wide range among commercial growers. A very successful Massachusetts specialist never uses less than two tons. The application, however, usually varies from one-half to one ton an acre.

535. Sowing in the field.—The great bulk of the onions grown in the United States is produced from seed sown in the open ground where the crop matures. This system is especially well adapted to conditions known to be highly favorable to the production of onions. Practically all of the American varieties, as Yellow Danvers, Yellow Globe, Southport Red Globe and Red Weathersfield, are grown from open ground seedlings.

Early seeding is regarded as of the greatest importance. As soon as the ground is fully prepared, the drills should be started. When wheel hoes are to be used it is customary to allow 12 to 14 inches between rows. When horse tools are employed in cultivating, the rows are made 24 to 30 inches apart. If the ground has been properly fitted for this crop, close planting and wheel hoe tillage will secure the largest profits. A small, well-trained mule can be used to draw the cultivator when the rows are only 18 inches apart.

In fairly heavy soil the seeds should be covered with not more than $\frac{1}{2}$ an inch of soil. Three-fourths of an inch is sufficient in most soils, while 1 inch or more will do no harm in very sandy types.

When the rows are 12 inches apart, $4\frac{1}{2}$ pounds of good seed to the acre will generally give a satisfactory stand of plants. More seed should be used in heavy soils, because the percentage of germination will be lower. Some thinning is practiced by most onion growers, but the more skillful ones avoid this tedious operation to a great extent. They invariably make germination tests before sowing, and regulate the drill accordingly. It is customary to allow 8 to 12 plants to the foot of furrow. The thinning is frequently attended to at the first hand weeding.

536. The transplanting method, known as the new onion culture, was developed simultaneously in 1888 and 1889 by T. Greiner of New York state and professor W. J. Green of the Ohio Experiment Station. It consists in sowing the seeds in hotbeds or greenhouses six weeks or more in advance of transplanting in the field. The advantages as stated by Professor Green (Ohio Sta. Bul. Vol. III, No. 9, p. 249) are as follows:

"1. Transplanting onions increased the yield 100 per cent in some cases and gave a decided gain with all varieties. The varieties that gave the best results were Pom-

peii, Prizetaker and White Victoria. Those showing the smallest gain were Danvers, Weathersfield and Michigan.

2. The transplanted onions were larger and more uniform in size than those grown from seed in the ordinary manner.

3. The transplanted onions ripened from three to four weeks earlier than those grown from seed sown in the open ground.

4. The extra labor involved in transplanting was offset by the saving of labor in weeding. The increase in crop, without a corresponding increase in labor, lessened the cost per bushel in production."

Investigations at many of the experiment stations have been favorable to this method of culture, which is popular with a large number of growers, although seldom practiced on a very extensive scale, except in the growing of Bermuda onions in the South. A Michigan grower transplants annually about seven acres and there may be gardeners who transplant even larger areas. The method unquestionably meets with favor among growers who have a market for large, fancy bulbs of the foreign type. Prizetaker is the most popular variety for this method, although other varieties of the foreign types are used.

The seed should be sown at least six weeks in advance of planting in the open ground. Many successful growers prefer 10 weeks, because it enables them to grow better plants.

Any rich, porous garden soil free from damping-off fungi may be used for starting the plants. Sow in drills $\frac{1}{2}$ inch deep and 3 inches apart. Ten or 12 seeds to the inch of furrow should give a good stand. A temperature suitable for other vegetables will meet the requirements of the onion. If hotbeds are used, a 3 x 6-foot sash should produce 8,000 or 9,000 plants. When set 4 x 15 inches apart in the field, 170,000 plants will be re-

quired for an acre. It is evident that about 20 sash must be employed to grow enough plants for an acre. The cost and maintenance of the sash and the care of the plants are more serious objections to the transplanting method than the cost of setting in the field. The plants must have good care to prevent damping off and to secure a strong, stocky growth. After they reach the height of about 5 inches they are clipped back weekly to about 4 inches to induce stockiness.



FIG. 90. ONION PLANTS CUT BACK PREPARATORY TO TRANSPLANTING.

The plants should not be set in the open ground until after danger of severe frost. Light frosts will do no harm. They should be thoroughly hardened by gradually subjecting them to lower temperatures and by watering more sparingly than at first. Before transplanting both roots and tops are cut back severely. They will stand transplanting better if the tops are shortened to about 3 inches. When properly grown they will be at least the thickness of a slate pencil (Figure 90) when transplanted. Dibbers are generally employed in field planting.

Watering is a great advantage after planting, although it is not necessary if the ground is naturally moist. To realize the largest profits by this method the large bulbs should be packed in crates of the Bermuda type. (Figure 91.)

537. Growing from sets.—Some market gardeners plant sets in small areas to produce mature bulbs and thousands of farmers depend upon them to supply the required quantity of bunching onions and mature bulbs

for the family table. This method has several advantages. (1) It is very convenient to all classes. There is no outlay for glass and no trouble in caring for plants previous to field planting, as is the case when the transplanting method is employed. (2) Fairly satisfactory results may be secured under conditions which would be unsuitable for the direct seeding or transplanting methods. (3) The bulbs mature considerably earlier than from seed sown in the field, and this may be the means of obtaining better prices than from seed-sown

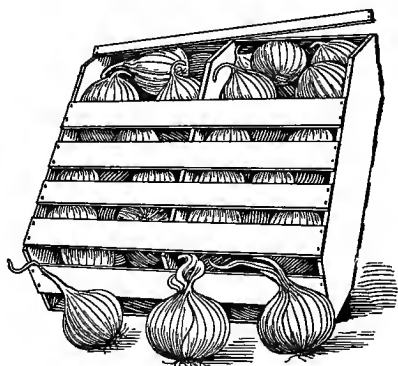

FIG. 91. ONIONS PACKED IN BERMUDA CRATE

onions. On the other hand, yields are generally smaller than from seed sown under favorable conditions. The expenses for sets and planting are important items when large areas are planted.

Mature bulbs are grown from three classes of sets; namely, top or tree onions, which produce sets instead of seed; potato or multiplier onions; and the small bulbs grown from very thick sowings.

Potato onions are used extensively in the South and are generally planted in the fall. Onion sets should be

planted as early in the spring as the ground can be prepared, as there is no danger of injury from freezing. The rows are usually 1 foot apart and the sets 3 inches apart in the row. They should be barely covered in the heavier soils; the depth slightly increased in sandy types. The number of bushels of sets required for an acre will depend upon the planting distances and the size of the bulbs. The quantity usually ranges from 8 to 12 bushels. A Massachusetts specialist plants about 20 bushels of sets to the acre. The gross sales of bulbs sometimes amount to \$500 an acre, although this is an unusual return from sets.

538. Cultivation.—As the onion is a shallow-rooted plant, care must be taken not to injure the roots by deep tillage. When hard rains incrust the soil before seeds have germinated, light raking or rolling will be an advantage. Horse cultivators are sometimes employed, especially in the heavier soils, which are difficult to work by hand. However, the additional spacing between rows, required for horse tillage, necessarily limits the yield. If ground has been properly prepared, there will be few instances when the rows should be more than 1 foot apart. Hand wheel hoes must then be employed in cultivating. Both single and double wheel types are in common use, but it is more economical to use double than single wheel hoes when the plants are small. Many growers prefer the single wheels at all stages of growth. Straight rows and uniform spacing are a great advantage in the operation of wheel hoes. The vertical shovels or teeth are most useful in heavy soils, while the horizontal sweeps are most serviceable in light soils. The latter attachments may be used without danger of covering the small plants. It is necessary to cultivate from 8 to 15 times during the season.

Hand weeding and thinning are required. This work is often done by boys and girls. The thinning is usually

performed at the first weeding, when 8 or 10 plants are allowed to the linear foot of row, but in very good soils and when large bulbs are desired, the plants should stand about 2 inches apart. Special hand weeders (Figure 7) are in common use. Both weeding and thinning should be avoided as much as possible by the proper preparation of the soil and the adjustment of drills. Figure 92 shows a well-managed onion field on Long Island.



FIG. 92. FIELD OF ONIONS ON LONG ISLAND

539. Irrigation.—In many sections of the West and the Southwest onions cannot be grown without irrigation, the ground being too dry to supply the moisture necessary. All of the Bermuda onions of the Southwest are grown under irrigation. The land is flooded before planting and afterwards at intervals of a week or 10 days until the bulbs are full sized, when water is withheld to induce ripening. An increasing number of growers in various parts of the country are employing the overhead system of irrigation, which is ideal when ap-

plied to this crop. Sprinkling before or after planting prevents the blowing of muck and sandy soils and the accompanying disastrous results in young plantations. Irrigation increases yields and insures the crop against loss from drouth.

540. Harvesting.—When the bulbs are to be stored they will keep better if allowed to become fully ripe before pulling. Figure 93 illustrates a field of onions in ideal condition for harvesting; the tops are dead and



FIG. 93. FIELD OF ONIONS AT HARVEST

shriveled and the outer skin of the bulbs dry. While full ripeness is highly desirable, other factors should be considered: There is danger of second growth, especially if there is much rain; better prices for the early crop may be an inducement to gather part or all of the crop sooner than if the bulbs are to be stored; when there are large areas to harvest it is necessary to start in ample time in order to complete the work while weather conditions are favorable and before there is loss

from rain. Harvesting is often begun when most of the tops have merely turned yellow. Early pulling in the North is especially important for bulbs of foreign types. August and September are the busy harvesting months in the North, and March and April for the Bermuda crop in the South.

It is the universal custom to partially dry or cure the crop in the field. After removing the bulbs by hand or with a plow, if they are covered with soil, 8 or 10 rows of onions are thrown together into windrows, allowed to remain undisturbed for a few days and then stirred occasionally with a wooden rake to facilitate drying. White bulbs are quickly injured by exposure to sun and rain, so that these must be cured under some kind of cover. Topping is usually done in the field after the bulbs are ready for storage, the tops being twisted off by hand or cut with sheep shears. Extensive growers sometimes use topping machines, which also grade and deliver the bulbs in bags or crates. The curing process is continued in sheds, cribs or other suitable houses until the bulbs are ready for permanent storage.

541. Storing.—Onions should not be stored until thoroughly cured. Soft and immature bulbs and bulbs with thick necks should be sold when gathered, because they will not keep well. A bright appearance is an important characteristic of the most salable bulbs. To secure this the crop should not be exposed to the weather longer than absolutely necessary. The onions are usually kept in crates or bags, in sheds, or covered in the field, for several weeks, and then screened to remove loose skins before placing in permanent storage. At this time they are also sorted to remove soft or decaying onions.

The United States Department of Agriculture (U. S. D. A. Farmers' Bulletin 354, p. 25) gives the following information in regard to storing this crop: "The essen-

tials for the successful storage of onions are plenty of ventilation, storing in small quantities, a comparatively low temperature, dryness, and safety from actual freezing. Any building wherein the above conditions may be secured will answer, but houses of the type shown in Figure 94, which are built especially for the purpose, are most satisfactory.

"The construction of the storage house should be double throughout, with plenty of felt or paper lining. Both top and bottom ventilation should be provided,



FIG. 94. ONION STORAGE HOUSE

and the ventilator openings should have windows that may be closed to control the temperature. The floors are constructed of narrow planks with $\frac{1}{2}$ -inch spaces between the planks for the passage of air. Bottom ventilation is frequently secured by means of drain pipes built into the foundation at the surface of the ground. These pipes are carried some distance toward the center of the house. They discharge the cool air at a point where it is most needed.

"The temperature of the storage house should be carried as low as possible without actual freezing. During

extremely cold weather the ventilator openings and doors should be kept closed, to keep out cold, and after the onions have become thoroughly chilled the house should be kept closed in order to hold the temperature down and prevent the entrance of moisture during warm or rainy periods. Damp, foggy weather is injurious to onions, especially if it follows a period of cold, and will cause the bulbs to become covered with moisture if the outside air is admitted. A little artificial heat from a



FIG. 95. ONIONS STORED IN CRATES

stove or a radiator may be required during excessively cold weather, but so long as the temperature in the house does not fall below 33 degrees there will be no danger of injury. A temperature of 34 to 36 degrees will give best results."

The crates previously referred to are 20 inches long, 16 inches wide and 14 inches deep, outside measurements. They are made of slats $\frac{3}{8}$ -inch thick and $2\frac{1}{2}$ inches wide, four pieces forming the side. The slats are

nailed to three-cornered vertical pieces of oak at each corner on the inside of the crate. When stacked in the storehouses (Figure 95) 1 x 3-inch strips are placed between them, to permit free circulation of the air. Although bags and bins are also used in storing onions, neither are as satisfactory as crates, because they do not allow so free a circulation of air and the space cannot be used so economically.

542. Marketing.—The bulbs are usually separated into three grades: *Primes*, which include bulbs $1\frac{1}{4}$ inches in diameter and larger; *seconds*, which are from $\frac{3}{4}$ inch to $1\frac{1}{4}$ inches in diameter; and *picklers*, which pass through a $\frac{3}{4}$ -inch screen.

Onions are marketed in a great variety of packages, as crates, bags, barrels and many different sizes and types of baskets.

543. Yields and returns.—Yields from seed sown in the open ground vary from 300 to 1,000 or more bushels an acre, but it is very rare that more than 1,000 bushels an acre are obtained by this method, and seldom that 900 to 1,000 are secured. Growers sometimes average 600, although 500 bushels is a good yield.

Estimates for the cost of growing vary extremely. A Michigan grower gives the following estimate for an acre:

Manure and hauling	\$15
Plowing and harrowing	8
Seed	8
Drilling	1
Cultivating	14
Weeding	16
Harvesting	10
Topping	8
Total	\$80

Estimates often run higher than this, sometimes amounting to \$150 or more an acre. For example, a successful grower in Massachusetts figures on spending \$154. He uses two tons of fertilizer, costing \$70 an acre. Gross receipts on this farm have run as high as \$500 an acre, while they generally range from \$200 to \$300. The price a bushel varies from 50 to 80 cents, sometimes more. A net profit of \$100 an acre is probably above the average.

In the growing of Prizetaker in the North the possibilities on limited areas are much greater. It is not difficult to grow 1,000 bushels an acre. This variety should average at least \$1 a bushel. The estimates of cost and profits by T. Greiner are as follows:

Rent of land	\$6
Manure, 3 carloads, at \$16	48
Fertilizers	25
Hauling and applying manure	12
Plowing and harrowing	3
Marking	1
Raising 180,000 plants	30
Seed	7
Transplanting	45
Cultivating and weeding	20
Pulling crop	3
Gathering, hauling, packing	35
Barrels and crates	60
	<hr/>
Total	\$295

RECEIPTS

By 1,000 bushels, at \$1, less freight, commission, etc.	\$800
Cost of production and packages	295
	<hr/>
Net profit	\$505

544. Bermuda onions.—In the South and the Southwest the seed is sown in specially prepared outdoor beds from the middle of September to the middle of October. The seedlings are transplanted in the field from November 20 to January 10 or even later. (U. S. D. A., Farmers' Bulletin 354, p. 31). The bulbs are generally harvested before fully ripe, by the use of a one-horse plow, potato digger or cultivator with cutter-wing attachment. After cleaning, drying (in the field) and topping, the bulbs are graded and usually sent to market in folding crates, about 20 inches long, 12 inches wide and 12 inches deep. They weigh 6 or 7 pounds, cost about 18 cents and hold 50 pounds of onions. The general average yield is 10,000 or 12,000 pounds an acre; the average price, \$1.60 a hundred weight. The buyer furnishes crates and loads the cars. The United States Department of Agriculture estimates the cost of production as follows:

Preparation of land and fertilizers	\$70
Seed	9
Transplanting	20
Irrigation	15
Cultivation and hand weeding	16
Harvesting	20
Interest on investment	20
Total	<u>\$170</u>

On heavily manured land the average yield is said to be about 16,000 pounds an acre, making gross receipts \$256 an acre and profits \$86. Much larger yields are often obtained, with profits correspondingly larger.

545. Growing sets.—Onion sets are very small matured bulbs of the same varieties as will grow to a large size when proper conditions are provided. These miniature bulbs are obtained by crowding, so that a dozen or more plants occupy the same space as one when large onions

are desired. The crowded plants compete with each other for food, moisture and room in which to grow. Under such conditions it is impossible for the bulbs to attain large size.

The industry has reached the greatest development near Louisville, Ky., and Chicago, Ill. There are from 600 to 800 growers of sets near Louisville, each cultivating from one to 50 acres. In the Chicago district the business is handled by 15 to 20 men, the acreage of each ranging from 20 to 400 acres.

Any good onion soil may be used for growing sets. It should be at least moderately fertile, fine and as free as possible from weed seeds. The seed should be drilled as soon as the ground can be prepared in the spring. In the districts mentioned the rows are 11 to 12 inches apart. Some highly intensive growers plant closer, but it makes cultivation more difficult. From 40 to 60 pounds of seed are used to the acre, and occasionally 10 or 15 pounds more. The seed is distributed in a broad drill by means of a spreader attached. Sometimes several hand drills are connected and drawn by a horse, but it is impossible to make the rows as straight as when the drills are pushed by hand. The fields must be cultivated as soon as the plants are up and frequently enough to keep the soil in good tilth. The number of cultivations varies from two to six, and of hand weedings from two to four.

With the crowded condition of the bulbs they mature earlier than if they had ample space. At Louisville harvesting begins in July and extends into August. The work is begun when one-third to one-half the tops are down. After loosening with a fork or an onion harvester, the plants are pulled by hand, the tops twisted off and the soil sifted out. Then the bulbs are placed in a barrel and taken promptly to the storage house, where the sets are spread 4 to 6 inches deep on trays and allowed to remain until sold. The cleaning before mar-

keting is done by hand or power machine, which removes chaff and dirt. The shrinkage in bulk from harvest until the middle of February is from 25 to 30 per cent. For this reason some growers prefer selling at harvest, when prices are sometimes nearly as good as in the winter.

One hundred barrels to the acre is a good crop. The average is from 60 to 70. Harvesting and cleaning costs 50 to 75 cents a barrel. Prices are extremely variable, but the industry is regarded as fairly profitable. White sets are in greatest demand.

546. Growing picklers.—Pickling onions are grown by the same method as sets, except that less seed is used. Twenty-five to 30 pounds an acre is sufficient. The bulbs range from $\frac{3}{4}$ inch to $1\frac{1}{2}$ inches in diameter. Uniformity in size is very important.

547. Bunching onions.—Immense quantities of onions are bunched when the tops are green and sold from early spring until midsummer. In the South, white and yellow multipliers are used; in the North, sets grown from seed and also those of the Egyptian tree onion.

Multipliers are generally planted in the fall, about six weeks before freezing weather. The trenches should be 4 or 5 inches deep and the bulbs set 3 to 6 inches apart. Large bulbs of the potato class, planted in the spring, will produce a great many small bulbs for planting in the fall of the same season. They will make a good start in the fall, grow to some extent during the winter in mild localities and make rapid progress in the spring. When multipliers are planted where the winters are severe, a mulch of some kind, preferably strawy manure, should be applied after the ground is frozen.

In the North, enormous quantities of sets are planted to produce bunching onions for local markets. It is customary to plant the sets 1 to 2 inches apart with 1 foot of space between rows, as soon as the ground can be prepared in the spring.

Because of its hardiness the Egyptian tree onion (top onion) is a favorite throughout the North. For the earliest bunching onions, the sets should be planted in the fall at least six weeks before freezing weather, and mulched if possible with manure, after the ground is frozen.

Considerable quantities of bunching onions are also grown from seed sown in the open ground, for marketing during the summer. This method requires the free use of seed, 20 to 30 pounds an acre. It is an economical method of production, and good profits are possible when prices are materially lower than for bunching onions grown from sets.

Bunching onions are sometimes prepared for market in the field (Figure 51), but it is better to take them to the packing shed, where the dead leaves can be removed and the onions properly washed and bunched. From 4 to 10 onions are tied in a bunch, the number depending upon size and market requirements.

548. Insects.—The imported onion maggot (*Pegomya cepetorum*) is closely related to the cabbage maggot (363). The carbolic acid emulsion treatment, previously described, is probably the most effective application. Rotation, however, is the most certain means of avoiding loss from this enemy as well as from all other insect and fungous pests of the onion.

The onion thrip (*Thrips tabaci*) is often a destructive enemy, especially in the South and in the Southwest, where Bermuda onions are grown. It is very minute in size, not exceeding 1-20 inch in length, and provided with sucking mouth parts and bristle-like mandibles. When present in large numbers thrips cause the plants to turn brown and die. Spraying with kerosene emulsion is considered the most successful treatment. Bordeaux mixture also serves as a repellent.

549. Diseases.—Onion smut is the most serious disease of the onion. It is likely to become particularly troublesome when rotation is not practiced. After the land is once infested, this fungus is exceedingly difficult to eradicate. The entire plant may be attacked, and the spores, forming a black dust, are readily disseminated by the wind, insects, and tillage implements. As the seed may also transmit the disease, it is sometimes soaked for about 20 minutes in a solution of formalin (1 ounce in 1 gallon of water), and thoroughly dried before being drilled. No method of soil or plant treatment has been found fully satisfactory.

Downy mildew (*Peronospora schleideniana*), which sometimes appears in warm, sultry weather, causes the leaves to blight. The spores present a downy, violet covering. Timely applications of bordeaux mixture will control this disease.

PARSLEY (*Carum petroselinum*)

550. Importance.—This biennial umbellifer, found wild in the south of Europe, was introduced into the English gardens in 1548. The crop is of limited commercial importance in the United States. It is unquestionably our most beautiful vegetable for garnishing, but not fully appreciated for this purpose. The leaves are finely cut, curled and valued for salads and flavoring as well as for garnishing.

551. Culture.—Extra Curled Dwarf is probably the most largely planted. Moss Curled, Fern-Leaved and Summer Green are also popular.

As the seeds germinate very slowly, they are often sown under glass, and transplanted once before setting in the open. The plants are hardy and may be taken to the open ground nearly as soon as cabbage. It is also customary to sow outdoors early in the spring or at

intervals during the summer. For the fall crop in the North, June is the proper time to sow. The rows should be about 14 inches apart and the plants 6 to 10 inches apart in the row. The leaves may be used as soon as they are large enough, and gathered during the entire season. Parsley will thrive in any moist, fertile soil. Nitrate of soda is especially valuable in securing rapid, tender growth. The leaves are tied together in small bunches for marketing. By protecting the plants in cold frames a supply throughout the winter is insured.

PARSNIP (*Pastinaca sativa*)

552. Culture.—The parsnip is an important root crop, belonging to the family of Umbelliferae. It is closely related to parsley, carrot and celery. The roots are boiled, fried and used in soups and stews. They are also popular for stock feeding.

Deep, fertile, sandy loams grow the finest roots. Clay soils have a tendency to produce crooked and branching roots, which are not wanted by the market. Under the most favorable conditions the roots will attain a length of one foot and will be straight and smooth.

GUERNSEY (STUDENT and IMPROVED HALF-LONG) is planted most extensively. HOLLOW CROWN, which is known by several other names, is also valued. EARLY SHORT ROUND is a small, very early variety, the roots of which are sometimes bunched with potherbs.

A full season is required to grow a good crop of parsnips. The seed, which germinates very slowly, should be sown as early as possible in the spring. A few radish seeds are sometimes sown with the parsnips. They germinate quickly, and the young plants mark the rows, so that cultivation may be begun before the parsnips are up. This method is especially desirable in soils which have a tendency to bake.

The soil should be thoroughly prepared before sowing. From $\frac{1}{2}$ to 1 inch of soil is sufficient covering. As the seedlings are very small and delicate at first, it is customary to use plenty of new seed, and then thin the plants to 6 or 7 inches in strong soils and 4 or 5 in poorer ones. There should be 15 to 18 inches between rows for wheel-hoe cultivation, and 2 feet or more when horse implements are to be used.

The roots may be used any time after they have reached maturity. Most gardeners who grow them in large amounts dig part of the crop in the fall, burying the roots in the ground or storing them in pits, caves or cellars. To prevent drying and shriveling in storage, they should be covered with moist sand or soil. As the roots are perfectly hardy in all parts of the North, the greater part of the crop is usually left in the ground where it was grown until suitable weather for digging the following spring. Freezing improves the quality (although this idea is sometimes refuted). The roots come out of the ground in a bright, fresh condition, and are salable on most markets. Parsnips are easily grown, and all markets should be well supplied.

PEA (*Pisum sativum*)

553. History.—Decandolle ("Origin of Cultivated Plants," p. 330) makes the following statement in regard to the origin of the garden pea: "The species seems to have existed in western Asia, perhaps from the south of the Caucasus to Persia, before it was cultivated. The Aryans introduced it into Europe, but it perhaps existed in northern India before the arrival of the eastern Aryans. It no longer exists in a wild state, and when it occurs in fields, half-wild, it is not said to have a modified form so as to approach some other species."

554. Importance.—The pea is one of the important

vegetables grown in the United States. It is almost invariably planted in home gardens, and truckers regard it as one of their leading vegetables for early and mid-summer sales. The crop is also canned to a great extent.

555. Composition.—The table in Chapter XXV shows that this is one of our most nutritious vegetables. Besides being wholesome, the young tender peas are regarded as a delicacy. Being a legume, the soil is improved by its culture and this advantage is considered by truckers who are alert as to methods of making their lands more fertile.

556. Varieties.—Varieties of peas may be classified as dwarf, half-dwarf and tall. The dwarf varieties, because they do not require support, are most largely grown. The tall varieties, for the ground occupied, produce much heavier yields, but must be supported. Varieties are also classified as smooth and wrinkled; there are dwarf and tall varieties of each class. The smooth peas may be planted earlier than the wrinkled, because they do not rot so quickly in the soil and the plants are hardier; but the wrinkled peas are sweeter and superior in quality.

A third class, known as edible-podded or sugar peas, is grown to some extent in this country. The young tender pods are excellent when properly cooked and seasoned. They may also be shelled, and only the peas eaten.

Among the many varieties of peas the following are the most important:

EXTRA EARLY SMOOTH PEAS

ALASKA is the most extensively grown for canning. The vines are 20 to 30 inches in height. The peas mature practically at one time. Uniformity in time of maturing is exceedingly important when the peas are

grown for the canneries. This variety is inferior to some other early varieties in flavor.

EXTRA EARLY. All of the seedsmen offer strains of extra early peas, often of the Alaska type. Some are probably superior to the well-known variety bearing this name.

EXTRA EARLY WRINKLED PEAS

GRADUS is a very early, largely planted variety. The large pods contain large peas which mature only a few days later than the smaller, smooth peas. Vines grow about 3 feet high.

THOMAS LAXTON is a close rival to Gradus, ripening a few days later. Pods and peas are large and of fine quality. Vines grow to the height of about 3 feet.

NOTT'S EXCELSIOR is an improvement on the old American Wonder, the pods being larger and the plants much more prolific. Average height is about 14 inches. It is a popular early variety of high quality.

MEDIUM AND LATE PEAS

IMPROVED STRATAGEM grows to the height of about 2 feet and does not need support. Pods are large and well filled with peas of the best quality.

TELEGRAPH, which produces very large pods containing 10 to 12 peas, is a popular variety.

Other varieties valued for late use are Fillbasket, Abundance, Champion of England, Duke of Albany, Laxton Evolution, Boston Unrivalled, Senator, Pride of the Market, Telephone, Lincoln and Long Island Mammoth.

Giant Sugar, Dwarf Gray Sugar and Mammoth Melting Sugar are the edible-podded varieties.

557. Climatic requirements.—The pea is sensitive to heat. It thrives best in cool weather. For these reasons

the large commercial plantings are made very early in the spring. The North naturally provides the best conditions, although excellent results are obtained throughout the South when advantage is taken of the cooler months. It is grown largely for northern shipments in some of the trucking districts of the South. There must be an ample rainfall to insure a full crop. In hot weather the growth is weak and mildew is liable to appear. Unless the growth is very tender, the plants will stand hard freezing, although they are sometimes injured when freezes occur after several days of good growing weather.

558. Soil.—A cool, moist but well-drained soil is essential to the largest yields. The sandy loams are preferred, although good results can be obtained on any loose, friable and well-prepared soil. The heavier soils are greatly improved for peas by the addition of humus in some form. Clay and silt loams are used advantageously for the late crop.

559. Fertilizing.—The pea does best in soils abounding in vegetable matter, but not containing excessive amounts of nitrogen. Land highly manured the preceding year furnishes ideal conditions for peas. Fresh stable manures should never be employed immediately before planting, but rotten manure may be used freely. When clover sods, crimson clover, cowpeas and soy beans are available to plow down, there is no need of stable manures. The bulk of the crop is grown by the use of commercial fertilizers. Although it is a legume, the early plantings begin growing long before nitrification is active, and some quickly available nitrogen is therefore essential for the early plantings. A small percentage of nitrogen is very generally regarded as profitable for plantings at all seasons, but there must be no lack of the mineral elements. Five hundred pounds of fertilizer containing 2 or 3 per cent of nitrogen and 8 to

10 per cent each of phosphoric acid and potash should meet the requirements of this crop. When grown for the cannery it is desirable to haul the vines back to the farm for their fertilizing value.

560. Planting.—For the earliest crop the seed should be planted in March or as soon as the ground can be prepared. Wrinkled varieties are often planted as early as the smooth sorts, but it is safer to plant them a trifle later. For the fall crop in the North, the dwarf varieties should be planted early in August.

The depth of planting must be determined by the character of the soil and the season of the year. For the first planting, shallow covering, probably with only an inch of soil, is an advantage, although 2 inches would not be too much in light soil. As the season advances, planting should be deeper, so that the roots will be where the soil is cooler and more moist. When planted 5 or 6 inches deep, the covering should be shallow at first, and the furrows gradually filled in after the plants are up.

Planting distances depend upon the height of the vines, whether the vines are to be supported or not, and the purpose of the crop. When grown for the cannery they are often sown with a grain drill, and the crop harvested with a mowing machine and a hay rake. They are also sown broadcast sometimes, and the seed harrowed in. When sown in drills the space between rows varies from 18 inches to 3 feet. It generally pays to use plenty of seed, especially with dwarf varieties. (See table in Chapter XXV.)

561. Supporting the vines.—When grown for commercial purposes the low varieties are generally planted and no support is provided. In smaller plantations, brush is often used. A neat, convenient method is to plant in double rows 6 to 8 inches apart, and stretch poultry netting of the proper height between the rows. Another very good plan is to drill in single (or double) rows,

drive strong end stakes on both sides of the rows, and plastering lath at intervals of 8 or 10 feet. The lath are driven opposite each other, brought together at the top and tied. Strands of common wrapping cotton are then stretched on both sides, from stake to stake as close together as may be necessary to give the proper support.

562. Harvesting and marketing.—Care must be taken to harvest the crop before the peas have hardened. When sold to canneries, peas are shelled by machinery, and the shelled peas passed through screens of various-sized meshes, the smallest peas bringing the highest prices. Profits are sacrificed if the crop is cut too soon. The peas are sometimes shelled before marketing, although they are generally sold in the pod in half-bushel and bushel baskets or hampers. If the peas are plunged in cold water before sending to local markets they will retain their plumpness and reach the market in better condition than if shipped direct from the field. With the early varieties, two or three pickings will remove practically the entire crop; the vines should then be plowed down and some other crop started. Gross receipts vary from \$40 to \$100 an acre, and sometimes even more. The cost of picking is the heaviest expense.

563. Enemies.—The pea aphid (*Nectarophora destructor*) is one of the most serious pests. It attacks the terminals of the young vines and soon destroys their vitality. Often large areas become infested and entire crops destroyed when conditions are favorable for breeding. Early planting or very late planting for canneries may be the means of escaping serious attacks. Kerosene emulsion is the standard treatment, which should be applied on both sides of the leaves as soon as the insects appear. Tobacco dust sprinkled on the young plants as soon as they are up is also valuable.

THE PEA WEEVIL (*Bruchus pisorum*) produces heavy losses sometimes. To avoid trouble from this pest, seed

peas should be treated with bisulphide of carbon at the rate of 1 or 2 ounces to 100 pounds of seed.

PEPPER (*Capsicum annuum*)

564. History.—According to De Candolle, the pepper probably originated in Brazil. It is now grown in many countries in nearly all parts of the world.

565. Importance.—The pepper is increasing in importance. Formerly, its culture was restricted to the hot, pungent varieties, but the introduction of the sweet peppers or mangoes has greatly extended its use. It has become an important crop on many truck farms, especially in New Jersey and in other sections near the large cities. The hot varieties are used for seasoning, while the mild sorts are valued for pickling and stuffing and to some extent for salad.

566. Climatic requirements.—Although this plant is most at home in tropical and subtropical countries, it is grown successfully in nearly all parts of the United States. It is tender to frost, but does not require as high temperatures as the eggplant. The conditions in South Jersey and southward along the Atlantic coast are excellent for this vegetable.

567. Soil.—The pepper thrives best in a warm, deep, fairly moist, fertile, sandy loam, although often grown commercially on moderately heavy soils. The drainage must be good. A southern exposure will hasten the maturity of the crop and be favorable to the largest yield.

568. Varieties.—Peppers are divided into two classes; namely, those which produce hot or pungent fruits and those which bear mild or sweet fruits, which are also called "mangoes."

PUNGENT-FRUITED VARIETIES

TABASCO produces an immense number of small, slender, very hot, bright-red fruits from which tabasco

sauce is made. It does not usually ripen fruit as far north as Pennsylvania.

LONG RED CAYENNE is well known for its pungency.

TRUE RED CHILI produces small, hot, bright-red peppers.

BIRD EYE OR CREOLE is the smallest red, extremely hot pepper.

HOT BELL has the same shape as Bull Nose, but the flavor is very pungent.

MILD-FRUITED VARIETIES (FIGURE 96.)

BULL NOSE is one of the most popular varieties.

CHINESE GIANT is extensively planted.

RUBY KING is a favorite with some growers.

NEAPOLITAN is a very early, extremely productive variety adapted to the cooler sections.

GOLDEN QUEEN is a large, sweet, yellow pepper.

569. Seed.—Seeds should be selected with the greatest care. Some successful growers produce their own seeds and maintain superior strains. To prevent the development of the pungent character in sweet peppers there must be no cross-pollination with hot-fruited varieties.

570. Starting early plants. The directions given for starting eggplants (454) under glass, apply equally well to peppers.

A high temperature is required to germinate the seed and to secure rapid growth in the frame or the greenhouse. As early peppers command the highest prices,



FIG. 96. MILD-FRUITED PEPPER

it generally pays to grow strong seedlings which will mature peppers at the earliest possible date.

571. Fertilizing.—Rotten stable manures may be used advantageously, especially in rather thin soil. Excessive amounts of nitrogen should be avoided, although it is important to supply the plants with an abundance of available nitrogen early in the season. The mineral elements are needed to encourage fruiting. From 600 to 1,000 pounds to the acre of a 4-8-10 fertilizer will produce satisfactory results in most soils.

572. Planting.—The plants should not be set in the open ground until the weather is settled and there is no further danger of frost. Fifteen to 18 inches between the plants in the row will furnish sufficient space for most varieties, and there should be about 30 inches between rows if the crop is to be cultivated with horse implements. Ridging is practiced to some extent to help support the plants when heavily laden with fruit.

573. Harvesting and marketing.—Peppers will remain on the plants after they have reached maturity, with no danger of deterioration, much longer than eggplants or tomatoes. They may be sold green or after they have turned red. Baskets of various sizes and styles are used in packing. Hampers of the bushel and half-barrel type (Figure 48, b) are in common use. The crop is also packed in barrels and in six-basket carriers (Figure 48, a). Receipts and profits have a wide range, but the net returns should not be less than \$100 an acre. Often they are larger.

PUMPKIN (*Cucurbita*)

574. Culture.—For cultural directions, see Squash (page 427) and Watermelon (page 467). Sweet pumpkins are sometimes grown on a small scale for commercial purposes.

RADISH (*Raphanus sativus*)

575. History.—The radish, which has been cultivated since earliest historic times, is indigenous to the temperate regions of the old world (De Candolle, "Origin of Cultivated Plants," p. 29). People of many countries consume the roots in large quantities.

576. Importance.—The radish is particularly important in this country as a spring and early summer crop. It is easily grown. The roots attain edible size in three to six weeks from time of sowing. As it is highly appreciated as a salad plant, immense quantities are grown by market gardeners supplying the city markets. It is also a profitable crop with some of the southern truckers, who ship to markets of the northern states.

577. Climatic requirements.—This is a cool-weather plant, but may be grown under a wide range of climatic conditions. If the supply of soil moisture is ample, high temperatures are not very damaging.

578. Soil.—The soil should be cool, moist, fertile and friable. Sandy loams are preferred. In heavy soils the roots are likely to be rough or ill-shaped, with a large number of small, fibrous laterals.

579. Varieties.—Wide variation exists in the character of the roots. In form they may be oblate, spherical, top-shaped, oval, oblong, conical or conical-cylindrical. In color they may be white, red, yellow, light brown, orange, red, purple or black. Some varieties are especially valuable for early spring planting, others for summer use and others for winter.

BECKERT'S CHARTIER is a favorite long radish, crimson, shading to white at the tip. It is a summer variety.

CARDINAL GLOBE is a valuable globular-shaped radish that matures very quickly.

CHINESE ROSE and NEW WHITE CHINESE are the most popular winter varieties.

EARLIEST WHITE is an early, olive-shaped variety prized in home gardens.

EARLY LONG SCARLET SHORT TOP is popular among market gardeners.

FRENCH BREAKFAST is a well-known bright carmine radish, clear white below.

HAILSTONE is a quickly growing white radish.

LONG WHITE VIENNA is valued as a summer variety.

ROUND RED FORCING is adapted to very close planting under glass or in the open, because of the small foliage.

SCARLET FRAME is a red, very early, turnip-shaped radish.

WHITE DELICACY is said to be an improvement on the White Strasburg.

WHITE ICICLE is a valuable, very early variety.



FIG. 97. RADISHES BUNCHED
FOR MARKET

580. Planting.—Radishes are planted from early spring, as soon as the ground can be worked, until six weeks before freezing weather. By the proper selection of varieties and sowing at frequent intervals a constant succession may be had throughout the season. The roots of winter varieties may be stored for consumption when they cannot be had from the garden or the field. The seeds are strong in germination, and should be sown thinly, to avoid a large amount of thinning. The distance

between plants in the row will vary from 1 to 5 inches depending upon the size of roots and tops. As a general rule the rows are 1 foot apart, although the small varieties may be planted much closer.

581. Fertilizing.—Decayed stable manures may be used in large amounts, but fresh manures should never be employed immediately before planting. A fertilizer carrying 4 per cent nitrogen, 8 per cent phosphoric acid and 10 per cent potash, applied at the rate of half a ton or more to the acre, should produce excellent results if other conditions are favorable.

582. Marketing.—Radishes are bunched (Figure 97) for market, the number in a bunch varying from 3 to 10. It is important to grade them. Grading, however, is generally neglected.

RHUBARB (*Rheum Rhabonticum*)

583. History and importance.—Rhubarb is indigenous to eastern Asia. It belongs to the buckwheat family, Polygonaceæ, and is a highly popular herbaceous perennial vegetable, being grown in nearly all home gardens. It constitutes an important crop on many commercial plantations. The succulent stems are used for sauce and pies.

584. Climatic requirements.—The roots are hardy. Although fall mulching is often practiced, it is unnecessary so far as root protection is concerned, whatever value it may have for other purposes.

585. Soil.—Deep, rich, sandy loams provide ideal conditions for rhubarb which, however, may be grown successfully on all types of soil put in the proper condition. The large leaves and succulent stems require an enormous amount of soil moisture, so that irrigation is especially valuable for this crop. The earliest marketings command the best prices. Warm soils sloping to the south are desirable when earliness is the chief consideration.

586. Propagation.—The plants are readily propagated from seed sown under glass or in the open, but as only

a small percentage of the plants produced in this way are true to type, the system should not be generally practiced. Root division is the method ordinarily employed. A piece of root containing a strong eye will grow and under favorable conditions produce a good plant in one season. Gardeners who force the crop in hotbeds or special buildings often lift the roots from old plantations in the fall, remove a sufficient number of eyes to start the new plantation the following spring and force the large, fleshy roots during the winter.



FIG. 98. A FIELD OF RHUBARB

587. **Planting.**—Fall planting is sometimes practiced, but spring planting is preferred. Early planting is important, because the plants need the entire growing season for their full development. The most common distances for planting are 3 x 4 or 4 x 4 feet apart. The roots or eyes are covered with several inches of soil. Victoria and Linnæus are the two most popular varieties. The former is somewhat the more vigorous. Linnæus (sometimes called Strawberry) produces beautiful pink stalks of the finest quality. Figure 98 shows a field of this variety in prime condition.

588. Fertilizing.—In the fertilizing of rhubarb the grower should consider, (1) that the plant luxuriates in soils abounding in vegetable matter, (2) that large stalks count for good prices, (3) that the early pullings are in most demand, (4) that the crop of any given year depends largely upon the care of the plants the preceding year.

Stable manure is especially valuable, because it supplies humus, conserves moisture and furnishes plant food. Some of the intensive and most successful growers use 25 or more tons to the acre. Manure is probably most effective when applied in the fall, although spring dressings are often made.

The commercial fertilizer should contain 4 to 6 per cent of nitrogen and 8 to 10 per cent each of the mineral elements. About 1,000 pounds an acre should be incorporated with the soil at the first cultivation in the early spring. Nitrate of soda is of great value when used at intervals throughout the growing season. Its use at the close of the harvesting season is advocated to develop strong roots for the next year's crop. The same principle is involved as in the fertilizing of asparagus. With proper care plantations will produce for many years. A mistake is made, however, by retaining them after the stalks become materially smaller. It is doubtful if the best profits can be realized in plantings more than five years of age.

589. Cultivation.—Thorough tillage throughout the season is highly important. Enormous amounts of water are used by the large leaves and succulent stems, and conservation of moisture is urgent. At the first operation in the spring the mulch of manure is worked into the soil. Subsequent tillage should be frequent, but not too deep. Some hand hoeing is generally necessary to keep the fields free from weeds. The seed stalks which generally appear on a small percentage of the plants should be broken off.

590. Marketing.—Harvesting begins as soon as the stalks have attained a length sufficient to satisfy the markets. The largest stalks are pulled, no attention being paid to the smaller ones, although the small stems are more tender for midsummer use. It is not customary to make heavy pullings until the third year from planting. Harvesting in any year should not continue until the plants are largely exhausted. Rhubarb is essentially a late spring and early summer crop. Ordinarily the season of marketing lasts about two months, May and June being the months when the crop is consumed most largely. From two to eight stalks are tied in a bunch. Red or blue tape adds considerably to the attractiveness of the product.

RUTABAGA (*Brassica campestris*)

591. Culture.—It is also known as “Swedish Turnip” and in England as “Turnip-Rooted Cabbage.” In composition and character of growth it is very similar to kohlrabi (page 349), and requires practically the same cultural conditions. The flesh is considered richer than that of the turnip. Rutabaga requires a deep, moist, fertile soil. For the early crop, the plants may be started under glass, as recommended for kohlrabi. The usual method, though, is to sow as soon as the open ground can be prepared, to produce the early crop. This vegetable is most largely consumed in the fall. It is also stored for winter use, being preserved in the same way as other root crops. For the late crop the sowings should be made in most sections from the middle of June until July 6. The plants should be thinned to about 8 inches apart. The spacing between rows may vary from 15 to 30 inches, depending upon whether hand wheel hoes or horse implements are to be used in cultivating. The roots will stand some freezing, so they need not be

harvested until late fall. They are valued for stock feeding.

SAGE (*Salvia officinalis*)

592. Importance.—Sage is a shrubby perennial, the fresh and dried leaves of which are used extensively for flavoring meats.

593. Culture.—It is propagated by cuttings, layers, division of the plants and from seed. If preferred, the plants may be started under glass, and transplanted to the open when weather conditions are favorable. A common method is to sow in the open, and thin as may be necessary. Sage is often grown as a second crop, following peas, cabbage or other early vegetables. The plants are hardy in the milder sections, but mulching with manure is important in the North for winter protection. A plantation will produce profitable crops for several years, when a new area may be set by dividing the roots. The usual distances for planting are 12 by 12 inches. Only one picking should be made the first year, or the plants will be greatly weakened. In subsequent years three pickings may be made in a season without serious detriment.

SALSIFY (*Tragopogon porrifolius*)

594. Importance.—Salsify, also known as the "oys'er plant" or "vegetable oyster," because of its flavor, is not generally used by vegetable consumers. The plant is native to southern Europe, biennial, but grown as an annual for the roots, which may be left in the ground all winter without danger of injury from freezing. The roots are long, tapering gradually, and seldom more than 2 inches in diameter at the top. They are cooked like parsnips, used in stews and soups, and sometimes in salads.

595. Culture.—The culture is practically the same as for parsnips. Seeds are sown in the open ground as early as possible in the spring, in rows 1 foot or more apart, and the plants thinned to 4 or 5 inches. The soil should be deep, rich and friable, sandy loams being preferred. Rigid thinning is essential to secure roots of good size. The seeds (botanically fruits) are much elongated, and for this reason difficult to sow with a drill. Market gardeners ordinarily dig some of the roots in the fall and store like parsnips. The remainder of the crop is left in the ground all winter and removed in the spring as soon as the frost is out of the ground.

SAVORY

596. Culture.—There are two kinds of savory, Summer (*Satureia hortensis*) and Winter (*Satureia montana*). The former is an annual; the latter a hardy perennial. Both species are grown for their leaves, which when fresh and green are used for seasoning. They may be started from seed sown under glass or in the open ground. The plants should stand 6 to 12 inches apart in the row with sufficient space between rows to use the wheel hoe or horse cultivator. When dried, the leaves and tender stem tips are used for culinary purposes during the winter.

SHALLOT (*Allium ascalonicum*)

597. Culture.—The shallot produces small, compound bulbs, called cloves. Instead of being inclosed in a thin membrane, as with the garlic, they are separate when mature. The flavor is somewhat milder than that of the onion. Any good onion soil will produce good shallots. The culture is the same as for onions.

SPINACH (*Spinacea oleracea*)

598. History.—This plant, which is considered native to southwestern Asia, was probably introduced into Europe during the fifteenth century. There is no assurance that it was known to the Greeks or Romans.

599. Importance.—With the exception of cabbage (which with propriety may be classed by itself), spinach is the most important crop grown for “greens” in the United States. In the North it was formerly a standard frame crop, but southern competition has made it of little importance there as a forcing crop, compared with lettuce and several other vegetables. It is grown mainly as a spring crop from sowings made in the fall. Spinach is grown on a very large scale about Norfolk, Virginia.

600. Varieties.—The Rhode Island Experiment Station (R. I. Sta. Bul. 41) has divided the varieties into four groups.

GROUP I.—**Norfolk, or Bloomsdale Spinach.** “Plants more or less vase-form, leaves broad, thick and supported by their stalks, so that they do not naturally rest upon the ground. Blossom stalks appear at an early age.” The Norfolk Savoy and other varieties belong to this class.

GROUP II.—**Round-Leaved Spinach.** “Plants compact in habit of growth, with leaves conspicuously rounded in outline and formed close to the ground. Tissue firm, color dark green, blossom stalks formed rather tardily. A slow-growing spinach as compared with the other types.” The well-known Victoria belongs to this class.

GROUP III.—**Thick-Leaved Spinach.** “Plants large, leaves long and spreading out upon the ground, ends and lobes of leaves more or less pointed. A highly prized type of spinach, both for spring and fall planting, on account of its large size and rapid growth.” Long Season is a good representative of this class.

GROUP IV.—**Prickly Seeded Spinach.** “Plants variable, leaves often with long and slender stalks and rather narrow blades. Seeds with hornlike projections. This kind of spinach is not readily sown with ordinary seed drills.” Prickly Seeded is a standard variety of this group.

GROUP V.—**New Zealand Spinach** (*Tetragonia expansa*) and GROUP VI.—**Mountain Spinach** (*Atriplex hortensis*) are not generally known among vegetable growers.

601. Culture.—A very rich, constantly moist soil is required to grow a heavy crop of spinach. In soils of moderate fertility the plants become spindling and the production light. Composted stable manures are especially valuable. The fertilizer employed should contain a high percentage of nitrogen. Mixtures used at Norfolk supply about 8 per cent of nitrogen, 2 to 5 per cent phosphoric acid and 2 per cent potash. They are used at the rate of about one ton an acre, applied in portions at different times throughout the season. The general practice is to make the fall sowings in low beds, 5 to 9 feet wide. This method provides perfect surface drainage. The rows, which should be 10 to 14 inches apart, are drilled lengthwise of the beds and the plants thinned 4 to 6 inches apart. It is important to sow in good time, so that the plants will become thoroughly established before winter. September 25 is the favorite time for sowing at Norfolk, although drilling begins about September 1 and continues until November 15. From 15 to 30 pounds of seed are required to the acre. Frequent tillage with the wheel hoe is just as essential as for other cultivated crops. In the North a mulch of manure or other material is valuable in affording winter protection, although in many districts this is not considered necessary. A push or shuffle hoe is often used in cutting the roots when the crop is gathered. The plants must be trimmed of

dead leaves to secure attractiveness when placed on the market. Half-barrel hampers and light ventilated barrels are generally used in marketing the southern crop. Early summer pickings may be secured in the North by sowing as soon as the ground can be prepared.

SQUASH

602. History.—There is considerable uncertainty as to the origin of the squash. *Cucurbita Pepo* and *C. maxima* are believed to be natives of tropical America, although



FIG. 99. BOSTON MARROW SQUASH

they are not known in a wild state. East Asia is probably the home of *C. moschata*.

603. Importance.—Although the squash is a fairly important vegetable, it is not fully appreciated by American consumers. It is widely cultivated by home and commercial producers, but large areas are not as general as they should be.

604. Summer varieties.—EARLY WHITE BUSH, MAMMOTH WHITE BUSH and JERSEY WHITE BUSH (*Cucurbita*

Pepo) are the leading varieties of the summer squashes of the "patty pan" type. YELLOW BUSH and GOLDEN CUSTARD BUSH are similar in growth and fruit to the first varieties named, except that the skin is deep orange in color instead of white. SUMMER CROOKNECK, and GIANT CROOKNECK, belong to the same species as the White Bush class, but their yellow skins and crooknecks make them distinct. The plants are highly productive and the quality of the fruit is superior to that of the patty pan class. They are grown to a considerable extent for the city markets.

605. Winter varieties.—The varieties of this class (*Cucurbita maxima*) are extremely variable in shape, color and size.

HUBBARD, extensively grown, is a large, fine-grained, dry variety of excellent quality. It is a good keeper.

WARTED HUBBARD resembles the Hubbard, but is more heavily warted.

GOLDEN HUBBARD is a favorite with some growers. The skin is salmon red when ripe.

BOSTON MARROW, popular in some sections, is grown extensively for storage.

DELICATA, MAMMOTH WHALE, GOLDEN BRONZE and ESSEX HYBRID are well-known varieties.

Cucurbita moschata is a third class represented by the WINTER CROOKNECK, DUNKARD and a few other varieties.

606. Culture.—The requirements of the squash are not radically different from other cucurbits. The plants, which are not nearly so tender as the melons, will stand more cold than cucumbers. Nevertheless, they are easily injured by frost, so that planting should not occur until the ground is thoroughly warm. A rich, warm, well-drained but moist soil is essential to quick maturity and high yields. The plants are often started under glass like cucumbers and muskmelons. The increased

earliness, due to planting under glass, is probably more marked than with any other cucurbit. The plan is popular for the summer crookneck type.

When planted in the open it is customary to sow 10 to 12 seeds in each hill, enriched with two or three forkfuls of rotten manure, and then to thin to two or three plants. Squashes are also planted in drills and thinned as may be desired. The bush types of patty pan and crookneck are generally planted 4 x 4 or 4 x 5 feet apart. The winter or running varieties need as much space as pumpkins and watermelons. Distances vary from 8 x 8 to 10 x 12 feet, depending upon the fertility of the soil and the vigor of the varieties. Figure 99 shows a field of Boston Marrow in Massachusetts with 12 feet between rows.

607. Marketing.—For local markets, summer squashes should be harvested before the rinds harden to any considerable extent. When to be shipped long distances, they must be fairly ripe in order to stand transportation. The barrel is the standard package for handling this vegetable.

608. Storage.—Successful storage depends largely upon proper methods of harvesting. The fruits should be removed with short stems before hard frosts arrive. They must be handled with the greatest care and placed promptly in heated buildings, which are often built for the purpose. It is customary to store squashes in bins or on racks, where, with the temperature above 50, they may be kept until May or June. Sweet potatoes and squashes are sometimes stored in the same house.

609. Enemies.—The common squash bug (*Anasa tristis*), which is so well known, is one of the worst insect enemies. The pests are unusually resistant to insecticides. Anything which is strong enough to kill the insects will also injure or destroy the vines. Hand picking of the insects and the eggs is effective but tedious.

The bugs may also be trapped under pieces of boards placed near the plants. Covering the young plants with mosquito netting is in many instances the most satisfactory method.

The Squash Vine Borer (*Melittia satyriniformis*) is often a destructive enemy. Early squashes are sometimes planted as traps. The vines, after the crop has been harvested, are pulled and burned. Thus, larvæ and eggs are destroyed and the seriousness of the attack upon the later plantings is reduced. Various cultural methods are employed in this connection.

SWEET CORN (*Zea mays*)

610. Importance.—This vegetable of American origin, developed from common field corn or maize, is of great commercial importance. It is very generally grown throughout the country and our markets are well supplied from July until cold weather. It is also grown extensively for canning, immense areas being planted annually in some sections for this purpose. With the improvement of varieties consumption is increasing.

611. Early varieties.—There is a long list of early varieties regarded as desirable by vegetable growers.

ADAMS EARLY is not a true sweet corn, but its quality is much superior to that of field corn. It is valued because of its hardiness and earliness. It may be planted at least 10 days earlier than the true sweet corn.

WHITE COB CORY is very prolific. It is a favorite with many growers.

FORDHOOK is very early and is planted extensively.

GOLDEN BANTAM is generally recognized as the most superior variety in cultivation in regard to quality. It is not quite as early as the better-known early varieties, but may be had throughout the season by planting in succession. It is especially desirable for the home garden, and is rapidly gaining popularity for commercial

purposes. There is usually some objection to the color, which is creamy yellow when the ears are ready for market, but the consumer seldom objects to the color after the corn has once been sampled. Other popular early varieties are STABLER, CROSBY, SHEFFIELD, RED COB CORY and MINNESOTA.

612. Midseason varieties.—Some of the best early varieties are often planted in succession to meet the demands of midsummer. When this is not desired the following second early varieties may be selected: COSMOPOLITAN, SWEET ORANGE (regarded as equal in quality to Golden Bantam) and KENDAL GIANT.

613. Late varieties.—COUNTRY GENTLEMAN and STOWELL EVERGREEN are the most popular and extensively grown late varieties and are used largely by the canning factories. Regarding their merits, the Maryland Station (Md. Sta. Bul. 120, p. 47) makes the following statement: "Stowell Evergreen gives a larger yield an acre and packs more cases a ton than most varieties. It usually commands about \$2 less a ton in price than the Country Gentleman. The latter variety gives a more desirable canned product and brings more money a case."

614. Seed.—The results, whether the corn is grown for the cannery or for market, depend largely upon the quality of seed planted. Some growers maintain special breeding plats. The reader should refer to Bulletin 183 of the Maine Experiment Station, and the circular prepared by Director Charles D. Woods, entitled "Practical Suggestions Regarding the Growing of Sweet Corn for Packing and for Seed." It is just as important for sweet corn growers to use high-grade, well-bred seed as for farmers to plant the best field corn. Experiments made at the Maryland Station (Md. Sta. Bul. 120) indicate that northern grown seed possesses no value over southern grown, but that acclimatization is essential to the best results.

615. Starting early plants.—With the use of paper pots it is thoroughly practical to start part of the crop under glass, and transplant to the open ground after danger of frost. The roots should not be disturbed, so that pots must be employed to make this method successful. Starting sweet corn under glass is not generally practiced, but if there is reasonable assurance of good prices the increased earliness will more than make up for the extra trouble and expense of starting the plants. It is doubtful whether the corn should be planted more than three weeks in advance of field planting. Any good compost may be used to fill the pots. About six grains should be planted in a 3-inch paper or earthen pot, and thinned to three or four plants, which later are set in the open ground. Cold frames may be used to start the plants, if a greenhouse is not available.

616. Fertilizing.—Soil well adapted to common field corn will produce good sweet corn, which thrives on heavy, clover sods plowed in the fall or early in the spring. Rotten or fresh manures of all kinds may be used to advantage. Eight or 10 tons of stable manure an acre applied on clover sod provides the most favorable conditions. Commercial fertilizers are also used in large amounts for the sweet corn crop, the applications varying from a few hundred pounds to a ton an acre. It is not uncommon for expert growers operating near good local markets to apply 1,500 pounds or a ton an acre, although 1,000 pounds is considered liberal treatment. The mixtures used for this crop generally contain 3 to 5 per cent of nitrogen and 7 to 10 per cent each of the mineral elements.

617. Soil preparation.—Sod land is invariably the best for sweet corn. Other fertile soils, cultivated the preceding year, may be used with success. Fall plowing of sods in northern sections is often desirable for the very early varieties. If plowing be deferred until spring,

there should be no delay. The harrow should be used promptly after plowing and often enough to conserve moisture and to prepare a thoroughly pulverized soil before planting time.

618. Planting.—When grown for market early planting is particularly important. It may be the means of getting a third or a half better price for most of the crop. Prices often decline very rapidly and a difference of several days earlier in reaching the market may make the average price for the season materially larger. In regions where sweet corn is grown for packing, late frosts sometimes catch the crop, and in such localities it is better to plant early and take risks of spring frosts, when replantings can be made if necessary, rather than to risk a total loss of the crop from autumn frosts.

It is customary to plant early, second early and late varieties at the same time, although some growers, especially those who produce their own seed, prefer to grow only one variety, planting at intervals of about 10 days to insure a succession of ears. There is no danger of mixing if only one variety is grown and this is a great advantage when a breeding plat is maintained.

Sweet corn is often grown in hills, but drills are preferred. Plants of the lower growing varieties may stand 10 inches apart, or perhaps slightly closer, while 1 foot is not too much space for vigorous sorts like Stowell Evergreen. The space between rows varies from 30 inches to 4 feet, depending upon the height of the plants. Three feet or less is ample for the early varieties, while the rank late varieties should have about 4 feet. A good stand is exceedingly important. It is best to seed freely, and thin if necessary to reduce the number of plants. Crowding is just as objectionable as is a poor stand. When planted in hills, more than four plants should never be allowed to remain. With the larger varieties three will probably give a better yield of salable ears.

619. Cultivation.—If rain falls after planting and before the plants are up, a weeder (Figure 6) should be used to break the incrustation. This implement may be employed with good results until the plants are a foot or more high. An occasional plant will be damaged, but the benefits are much greater than the injuries. The damage will be least if the weeder is used in the middle of the day, when the plants are less rigid, than earlier or later. Various other tools, the spike-tooth type and the riding cultivators, are employed in caring for the crop, and some hand hoeing is usually required.

620. Suckering.—Suckering is not as beneficial as some growers suppose, but it is generally regarded as a profitable operation. Some varieties sucker much more freely than others.

621. Marketing.—Sweet corn is often harvested before it is ready. The kernels should be plump, but not hard. It pays to exercise care in regard to this matter, for uniformity in size and degree of ripeness is an important factor in commanding remunerative prices. The crop is shipped in barrels, hampers and crates of various sizes.

622. Returns.—Sweet corn, under favorable conditions, is a profitable crop. Prices paid by the packers range from \$9 to \$12 a ton, and about \$3 more when the husks are removed. Maine canneries pay 2 cents a pound for the corn cut from the cob. This is the fairest way to sell sweet corn. It also encourages good breeding. Prices on the market vary from 5 to 25 cents a dozen ears. Gross receipts have been known to run as high as \$350 an acre, but this is very unusual. A gross return of \$100 makes corn a profitable crop, especially when the fodder is used properly on the farm. Many general farmers, who grow sweet corn on a large scale for market or for packing, cut the fodder into silage as soon as the crop is sold.

SWEET POTATO (*Ipomoea batatas*)

623. History.—There is no definite knowledge of the origin of the sweet potato, although it is believed the plant is native to the West Indies and Central America.

624. Botany.—The sweet potato is perennial, although it is grown as an annual. It belongs to the morning-glory family or Convolvulaceæ, the flowers with purplish throats and white margins, resembling those of the morning glory. The blooms are rare and may not produce seed. The trailing vines strike root at the joints and bear leaves which vary greatly in shape, being of three general types, viz., entire and not lobed, shouldered and lobed, and deeply cut and lobed. The general form of the leaf is heart-shape or halberd-shape. The tubers are also variable in shape, size and color. Some are long and cylindrical, others short, thick and blunt at the ends. The skin may be whitish, dull straw-color, light red or purple. The flesh is also variable in color, texture, moisture and quality. Classification of varieties is usually based upon the shape of the leaves.

625. Importance.—The sweet potato is one of the most important vegetables grown in the United States. It is consumed in enormous quantities throughout the South, where it is generally grown. The average annual production in the United States is about 50,000,000 bushels. Every northern market is well supplied during most of the year. The sweet potato is grown much more extensively than the white potato in the southern states, and is a popular vegetable in practically all tropical countries, constituting in many instances an important source of food. The tubers are fried, baked, boiled and braised, and also used for pies like pumpkins. A considerable quantity is canned. In some sections the potatoes are fed to sheep, hogs and cattle. They may become important for the manufacture of denatured alcohol.

626. Varieties.—Figure 100 shows some of the most important varieties. The shape is extremely variable. While there are a great many so-called varieties in cultivation, not more than 10 or 12 are of great commercial importance. According to Beattie (U. S. D. A. Farmers' Bulletin 324, p. 35), BIG-STEM JERSEY, YELLOW JERSEY and RED JERSEY are the best representatives



FIG. 100. SOME OF THE COMMERCIAL TYPES OF SWEET POTATOES. (1) BLACK SPANISH OR "NIGGER CHOKER"; (2) LONG, JERSEY GROUP; (3) LONG, CYLINDRICAL TYPE; (4) RED BERMUDA; (5) SOUTHERN QUEEN.

of the Jersey group (dry, mealy-fleshed varieties) and SOUTHERN QUEEN, PUMPKIN YAM, GEORGIA, FLORIDA and RED BERMUDA are the most important varieties of the yam group (moist-fleshed varieties). In selecting varieties for local sales, market demands should be considered. Red potatoes sell most quickly on some markets, while others prefer white. Soil and climatic conditions must also be regarded.

The following descriptions of leading varieties have been prepared by Beattie (U. S. D. A. Farmers' Bulletin 324, p. 35):

BIG-STEM JERSEY. This variety is the most popular among growers who are supplying northern and eastern markets. It is a form of the Yellow Jersey, having been selected for its productiveness and dry, yellow flesh. The vines are slender and long; the potatoes are of spindly shape and inclined to grow rather large; color of potatoes yellow; color of flesh light yellow or deep cream. While this variety yields heavily, it is unfortunately a rather poor keeper, and its flesh is inclined to become dry and "punky" toward spring. It will thrive well toward the North, but is better adapted for use as a commercial variety than for home consumption.

YELLOW JERSEY. The vines of the Yellow Jersey variety are long and more slender than those of the Big-Stem Jersey, and the potatoes are of spindle shape, but much smaller; otherwise the two varieties are very similar in appearance. The flesh is dry and mealy. This variety is a fairly good keeper and retains its quality well. It is adapted for home use and thrives under a wide range of conditions, but does not yield heavily enough for commercial purposes.

RED JERSEY. This is similar to the Yellow Jersey variety, except that the roots are red and it is more productive under most conditions. It is suitable for home use.

SOUTHERN QUEEN, OR HAYMAN. The vines of this variety are strong and vigorous; the potatoes are large, thick, and blunt at ends or of short spindle shape; the color is white or light cream, while the flesh is of cream color, becoming darkened in cooking, moist, and very sweet. This variety is most extensively grown for market purposes where a sweet, moist-fleshed potato is demanded. The Southern Queen yields well, is an excel-

lent keeper, and is adapted for both marketing and stock feeding and for home use in the South Atlantic and Gulf Coast States, but it does not mature when grown in the extreme North.

PUMPKIN YAM. The vines are vigorous, short, sometimes of a bunch habit. The potatoes are of short spindle shape or quite round, with a dull yellow color on the outside. The flesh is orange or sometimes yellow and marbled with orange; it is moist and has a flavor very similar to that of good squash. This variety yields well and is adapted to home use and to stock feeding throughout the South.

GEORGIA, OR SPLIT-LEAF, YAM. The vines of this variety are slender and long; the potatoes of medium size, spindle shape, yellow; the flesh a light yellow, marbled with salmon. The quality of this variety is excellent and very sweet, but it is a light yielder. It is a splendid sort for home use throughout the South Atlantic and Gulf Coast States.

RED BERMUDA. The Red Bermuda vines are large and vigorous. The potatoes are usually large and overgrown with heavy ridges and veins. The color of the potatoes is rose red; flesh, creamy; quality fair but not so sweet as Southern Queen. This variety is a heavy cropper and suitable for feeding to stock. It is one of the few so-called yams which thrive in the northern portion of the sweet potato area.

FLORIDA. The vines of the Florida variety are large and vigorous. The potatoes are rather large, light salmon yellow, smooth and regular, of short spindle shape, with light yellow flesh. This variety is not so sweet as the Georgia and is inclined to be dry and mealy. It yields fairly well and is adapted for home use.

PIERSON. The vines of the Pierson are similar to those of the Red Bermuda variety. The potatoes are light yellow, of short spindle shape, very rough, with cream-

colored flesh. This sort is extensively grown for the earliest market, but it is of only fair quality. It yields well if allowed to remain until late in the season.

BLACK SPANISH, or "NIGGER CHOKER." The Black Spanish vines are very long, vigorous, and dark purple in color. The potatoes are long, cylindrical, crooked, or bent; dark purple in color, with snowy white flesh and poor quality. This variety is grown mostly for stock feeding.

SHANGHAI. The vines of the Shanghai variety are large and vigorous; the potatoes long, cylindrical; the outside color almost white. The flesh is creamy white, becoming darker in cooking. When baked the flesh is somewhat dry and mealy and the flavor rather poor. This variety yields fairly well and is adapted for use as stock food in the Gulf Coast States.

627. Climatic requirements.—There are extensive areas in the United States which are well adapted to sweet potatoes, mainly because of suitable climatic conditions. The plant is very tender and demands high temperatures. An abundance of sunshine is essential to high yields. Although a liberal rainfall is desirable during the growing season, it is detrimental when the tubers are maturing, because it encourages excessive vine growth at the sacrifice of tubers. There should be a growing season of not less than $4\frac{1}{2}$ months without frost. Warm nights are important to obtain the best results. This vegetable is often grown in northern gardens, but it is futile to attempt its cultivation commercially where climatic conditions are unsuitable.

628. Soils.—The lighter soils are invariably regarded as the best for sweet potatoes. A moderate proportion of sand in the top soil, with a fairly retentive subsoil, provides ideal conditions. Whatever the soil type, it must be warm, loose and well drained. Stiff, heavy soils should never be planted with this vegetable. When it is necessary to use such soils in supplying sweet potatoes

for the home table, their structure should be modified by the addition of large amounts of vegetable matter. The vine growth is likely to be excessive on stiff soils and the tubers are rough and unsymmetrical. New land is regarded as especially valuable for this crop. Calcareous soils, when properly handled, often produce good results. Some of the driest and most sandy soils give good yields of fine tubers when seasonal conditions are favorable. Sweet potatoes can often be made to pay on lands too poor for cotton or tobacco, although the highest yields cannot be expected in impoverished soils.

629. Seed.—The tubers for the propagation of plants for next year's crop should be selected when the crop is dug. Some growers attend to this matter with the greatest care. Individual hills are studied and the tubers are chosen with reference to productiveness, size, shape and uniformity. With white potatoes, hill selection has been clearly demonstrated to be valuable, and there are reasons for its practice with sweet potatoes, but the experimental evidence in its favor is not very conclusive. The same may be said with reference to the use of tubers of various sizes. The experiment stations have not been able to show that it is profitable to use large tubers for seed, although there is some evidence in their favor. In many regions of prominence the small tubers are chosen because they keep better than large ones in storage, are worth the least on the market, and a bushel will produce a greater number of plants than larger tubers. When several "drawings" are made, from $1\frac{1}{2}$ to 2 bushels of small potatoes are required to grow enough plants for an acre; 2 to 4 of medium size and 4 to 10 of large size to plant the same area. (U. S. D. A. Farmers' Bul. 26, p. 9). The medium size, 2 inches in diameter or less, is preferred by many growers. A bushel will produce from 2,000 to 2,500 plants when two drawings are made. Varieties vary greatly in their

power of reproduction, and this difference is often recognized in the charges made by plant dealers. In the far South, where the summers are very long, so that cuttings may be made with freedom after the plants begin to vine, an acre in the field may produce enough plants for 1 to 4 acres, although too severe pruning will reduce the yield on the propagating area. Plants from cuttings are said to produce the best seed. Whatever the size of



FIG. 101. FRAMES FOR GROWING SWEET POTATO PLANTS

tubers selected, they should be handled with extreme care to prevent bruising and injury and kept as directed in the notes on storage (637). Freedom from disease is especially important.

630. Propagation.—Sweet potatoes are usually propagated by means of “slips,” also known as “sets” and “draws.” The tubers are first bedded in fine soil, with proper heat and moisture. The potatoes sprout and produce rooted plants, which are removed and planted in the field after all danger of frost has passed.

Ordinary hotbeds are often used in propagating the plants. The amount of manure required depends upon the locality. A depth of 1 foot of fresh manure is usually sufficient. The soil is not added until the bed has begun to heat.

In some sections through the northern area of the sweet potato district flue-heated beds are employed. These are very common in New Jersey. Figure 101 shows such a structure with the canvas covering removed. The canvas is kept over the beds during the early stages of rooting and removed later when weather conditions permit, but replaced in cold or frosty weather. The flues may be built of wood, tile, concrete or brick. The walls of the bed are of any desired construction, and frequently sash are used for covering instead of canvas.

Pipe-heated beds are popular in some sections. Beat-
tie (U. S. D. A. Farmers' Bul. 324, p. 12) gives the following description of this method: "Where a steam or hot water boiler is in use for greenhouse or residence heating, a very satisfactory plant bed can be constructed by burying four or five lines of pipes in the soil beneath the bed and supplying the heat from the boiler. This has been found to be an ideal method, as the lines of pipes can be controlled by valves and the temperature of the soil in the bed kept at the desired point. If hot water heat is used the pipes should be laid with the soil in direct contact with them, but for steam the pipes should be surrounded with 3-inch or 4-inch tiles to prevent too rapid passage of the heat and the consequent burning of the soil. The pipes should be placed 10 or 12 inches below the bottom of the special soil in the bed, and 14 to 16 inches below the line of the seed potatoes. If the pipes are laid 18 inches apart, an even distribution of heat will be secured. For hot water heating, 2-inch pipes should be employed, but 1¼-inch pipes will be

large enough for steam, provided the lines are not more than 60 feet in length. The lines of pipe should be carefully graded and have a uniform fall toward the return end; in fact, the rules governing greenhouse heating apply to the piping of beds of this kind. A general idea of the construction of a pipe-heated bed may be gained from the cross section shown as Figure 102.

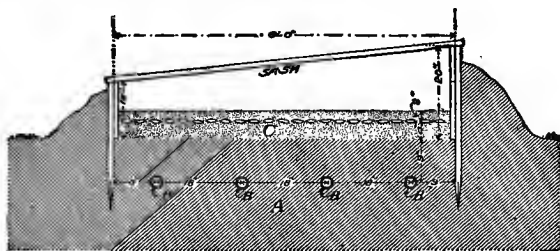

FIG. 102. CROSS-SECTION OF PIPE-HEATED FRAME

In the far South it is not necessary to provide any kind of protection to the seed bed. In the North, protection with glass or canvas will serve the purpose without artificial heating.

Any fine, light, sandy soil may be used for bedding the potatoes. First, there should be several inches of soil in the bed and the upper inch free from all coarse materials. Then the tubers are placed, by hand, on the surface of the bed so that they do not touch each other. Very large potatoes may be split lengthwise, the cut surfaces being placed next to the sand. After placing tubers, cover them with about 3 inches of fine soil and then water thoroughly.

At the time of bedding the temperature of the bed should range from 80 to 85 degrees and be gradually dropped during a period of six weeks, perhaps, to about 60 degrees, when the plants may be set in the field if weather conditions are suitable. The air temperature

in the frame should never fall below 60, and higher temperatures are preferred for some time after the tubers have been bedded. Watering and ventilation must be attended as changing weather conditions demand. Flue or steam-heated frames require more frequent and abundant watering than manure-heated and nonheated beds. Strong, healthy plants are essential to large yields, but good plants cannot be grown without close, daily attention.

In the extreme South the tubers are sometimes cut into pieces and planted like white potatoes, and again the small tubers are occasionally planted whole and cuttings made to extend the plantation. Vine cuttings are commonly used in the most favorable regions. They are usually 10 or 12 inches long, and are made after the plants begin to vine. When planted, they are placed horizontally or obliquely with only 1 or 2 inches of the tip projecting above ground.

631. Soil preparation.—Weeds must be guarded against by clean cultivation, in making preparations for a crop of sweet potatoes. Rotation is important. A thoroughly cultivated crop, followed by crimson clover, puts the soil in excellent condition for planting sweet potatoes. In sections where climatic conditions permit, it is customary to grow an early crop of peas, beans, cabbage or other vegetables before planting sweet potatoes. While a comparatively dry soil is essential to this crop, the supply of moisture must be ample at transplanting, a fact which must always be kept in mind in all preparatory tillage operations.

632. Fertilizing.—A yield of 200 bushels an acre will require, for the tubers alone, 30 pounds of nitrogen, 10 pounds of phosphoric acid and 45 pounds of potash. While these figures indicate the need of rather large amounts of nitrogen, it is universally conceded that excessive applications of this element produce too much

vine growth at the expense of tuber development. It is also agreed that free applications, unless too liberal, will increase the yield, but the quality will be inferior. Nitrogen, however, must be used under most conditions, and it is probable that not less than 3 per cent will produce the best results, unless manure has been used or a leguminous cover crop has been plowed down. In the far South probably all of the nitrogen should be derived from organic sources, while in the North a portion should be in soluble mineral forms.

The mineral elements are much more important than nitrogen. They are essential to large yields of high quality, but potash is more important than phosphoric acid. The growers of the famous sweet potatoes at Vineland, New Jersey, use fertilizers carrying about 3 per cent of nitrogen, 7 per cent of phosphoric acid and 12 per cent of potash. Voorhees ("Fertilizers," p. 223) recommends, to the acre, 20 pounds of nitrogen, 50 pounds of phosphoric acid and 80 pounds of potash. At the Georgia Station (Ga. Sta. Bul. 25, p. 128) 320 pounds of acid phosphate, 360 pounds of cottonseed meal and 640 pounds of kainit an acre have given the best results. Beattie (U. S. D. A., Farmers' Bul. 324, p. 7) recommends a mixture composed of 200 pounds of high-grade sulphate of ammonia, 200 of dried blood or 300 of fish scrap, 1,200 of acid phosphate and 400 of muriate of potash. Applications of fertilizer vary from 200 to 1,000 or more pounds an acre, depending upon the condition of the land. The best results are obtained from dressings made from 10 days to three weeks before planting. When very large amounts of the mineral elements are employed, it is especially important to apply them well in advance of planting, because the tender plants are very susceptible to injury from burning.

Stable manures are sometimes used in sweet potato culture. They are most valuable on thin lands deficient

in vegetable matter. It is better, however, to apply them to a hoed crop the previous year, but, if this cannot be done, they must be thoroughly rotted, to prevent excessive vine growth.

633. Planting.—Field planting should not begin until the ground is thoroughly warm and there is no further danger of frost. The favorite time is before and after rains. If the ground is dry success is more certain when a small quantity of water is used with each plant than



FIG. 103. SWEET POTATO SETS OR DRAWINGS

if the plants are set in the dry soil. If level culture is practiced the usual planting distance is 24 x 30 inches. When planted on ridges, a very general practice, the plants are usually spaced 14 to 18 inches apart in the rows, with 36 to 42 inches between rows. It is customary to plant from 8,000 to 12,000 plants an acre.

The plants should not be "drawn" until well rooted. (Figure 103.) To remove a plant from the tuber, hold

the potato in place with one hand and pull with the other. The roots are often puddled before transplanting. This is especially valuable when conditions are not very favorable for the work. On small areas the plants are often set by hand, by the use of dibbers or trowels. In some sections, special tools known as tongs, shovels and dibbers are employed. (See Farmers' Bulletin 324, pp. 20 and 21, U. S. D. A.) Horse transplanting machines are often used in setting large areas.

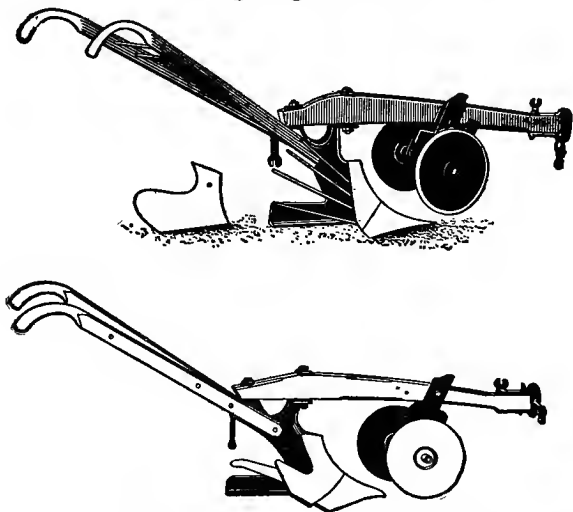

FIG. 104. PLOWS FOR HARVESTING SWEET POTATOES

634. Cultivation should be started as soon as possible after planting. The loose soil in the alleys is gradually worked toward the rows, forming broad, flat ridges. Spike-tooth cultivators are then used as often as necessary, until vine growth prevents further tillage. Some hand hoeing is usually necessary, but this should be avoided as much as possible and should be reduced to a minimum when the plants are set in check rows.

635. Harvesting.—Sweet potatoes are palatable as soon as they have attained a size large enough to be worth cooking, but the yield is always greatly sacrificed if dug too early. High prices may make up for the reduced yield. Various types of plows are used in the removal of the crop, but the special forms shown in Figure 104 are the most desirable for this work. Sweet potatoes should, if possible, be harvested before frost. It is also important that the ground be dry and the weather bright and sunny to favor the rapid drying of the tubers, which should never be left on the ground during the night. The usual plan is to allow them to dry in the field for a few hours and then haul them to temporary or permanent storage.

636. Marketing.—Sweet potatoes are marketed most extensively in barrels. Hampers and baskets are often used for local markets. When shipped during the winter, the barrels should be lined with paper and the tops provided with several layers of heavy paper. Additional protection is afforded by covering the outside of the barrel with heavy paper. After being taken from storage in cold weather they should be handled as rapidly as possible until safely in the home of the consumer. Car lots in the winter require refrigerator or felt-lined cars. Stoves are sometimes provided to guard against frost.

637. Storage.—A relatively high temperature and a dry atmosphere are the requisites for the successful storage of sweet potatoes, which in the South are usually kept in pits or outdoor cellars. In the North special houses (usually frame) are built and heated with stoves or hot water. They are well provided with ventilators. The potatoes are placed in large bins immediately after they have been dug; the fires are started as soon as storage begins, and a temperature of about 85 degrees maintained during the storing period and for 10 days after all the potatoes have been housed. This period is

known as the "sweating" stage, after which the temperature is gradually lowered and maintained between 55 and 60 degrees. For a full discussion of storage, see Farmers' Bul. 324, pp. 29-34.

638. Returns.—In the large commercial districts it is estimated (Farmers' Bulletin 324, p. 38) that the acre-cost of production is about as follows: Rental of land, \$8; plowing and fitting, \$5; fertilizers, \$20; 10,000 plants, \$10; planting, \$5; cultivating, \$5; digging and marketing, \$25; total, \$78. Average yield, one barrel to 100 hills or 100 barrels an acre. Prices range from \$1.25 to



FIG. 105. HARVESTING THYME

\$3 a barrel (sometimes more) and \$75 is about the average profit to the acre, although \$100 to \$150 is sometimes realized.

639. Insects.—The sweet potato has fewer insect enemies than many other vegetables. Cutworms are troublesome sometimes, especially in sod lands. The sweet potato borer, destructive to the roots of the plants, causes the greatest damage to the crop in the Gulf Coast States.

640. Diseases.—Although there are several diseases that cause more or less trouble in the field or when the

tubers are in storage, the black-rot (*Sphaeronema fimbriatum*) is the most destructive. This fungus attacks the young plants as well as the roots and tubers. Rotation and the planting of healthy tubers are the most important means of control. Bulletin 76 of the New Jersey Experiment Station gives complete descriptions, with illustrations of the most important diseases.

THYME (*Thymus vulgaris*)

641. **Culture.**—Thyme (Figure 105) is a popular herb used for seasoning. It may be propagated by means of seeds, root divisions and layers. The plants should stand about 6 inches apart in the row, the distance between rows depending upon the method of cultivation. It thrives in any good soil. The leaves are picked and sold at once or dried and preserved for winter sales.

TOMATO (*Lycopersicum esculentum*)

642. **History.**—The tomato is native to South America. It was grown by the aborigines. There is abundant evidence that the varieties first cultivated in European countries originated in America. Although students generally agree as to the place of origin of cultivated forms, there is no definite record or history concerning them. Deductions from the studies of Sturtevant lead to the conclusion that large, smooth specimens were grown at least 200 years ago. Tracy ("Tomato Culture," p. 15) states: "In the transactions of the London Horticultural Society for 1820, John Wilmot is reported to have cultivated under glass in 1818 some 600 plants, and gathered from his entire plantings under glass and in borders some 130 bushels of ripe fruit. It is stated that the growth that year exceeded the demand, and that the fruit obtained was of extraordinary size, some exceeding 12 inches in circumference and weighing 12 ounces each."

The same writer asserts that it was grown for culinary use in Virginia in 1781. A Frenchman grew and attempted to sell tomatoes to Philadelphians in 1788, but with poor success. An Italian made a similar effort at Salem, Mass., in 1802. Tomatoes were quoted in the New Orleans market in 1812, and offered by seedsmen as an edible vegetable in 1818. The plant gained rapidly in popularity after 1820, and was a standard vegetable in many sections in 1835.

643. Classification.—Cultivated varieties of tomatoes vary considerably in most of their characteristics. Bailey ("The Principles of Vegetable Gardening," p. 401) has prepared the following classification:

I. *Lycopersicum pimpinellifolium*. This class has not yet varied to any extent in cultivation. The one variety is known as the currant, or German raisin.

II. *Lycopersicum esculentum*. The parent of all commercial tomatoes. (a) Var. *Cerasiforme*. Cherry tomatoes, characterized by slender growth, small, light-colored leaves, and small globular fruits, normally two-celled. Red and yellow varieties are known. (b) Var. *pyriforme*. Pear and plum tomatoes, distinguished from the preceding subdivision by the pear-shaped or oblong, pendent fruit. Red and yellow varieties are known. Nesbit's Victoria has foliage much like that of Section d. (c) Var. *vulgare*. The common tomatoes, represented by three main groups, viz., (1) oblong tomatoes, represented by King Humbert; (2) angular tomatoes (scarcely known in this country); and (3) apple-shaped tomatoes, represented by the Peach. (d) Var. *grandiflora*. Large-leaf tomatoes, represented by Mikado. (e) Var. *validum*. Upright tomato, represented by Dwarf Champion.

644. Importance.—Immense quantities of this vegetable are sold on the American markets. The tomato is a standard truck crop near all of the larger towns and

cities, and is grown extensively in the South to supply the northern trade. Thousands of acres are planted annually for canning and catsup. The home garden always contains at least a few tomato plants. The fruit is now so popular that hundreds of greenhouses are devoted to its culture to supply the trade during the winter or cooler seasons of the year. It is also an exceedingly popular fruit or vegetable in many foreign countries.

645. Climate.—The tomato is readily injured by cold. It requires rather high temperatures and plenty of sunshine for its best development. Eighty to 90 degrees during the day and 15 to 20 lower at night provide the most suitable growing temperatures. Daily sunshine is always an advantage. Notwithstanding the fact that these conditions are important, the crop is grown under a wide range of climatic conditions. Good local markets often make it profitable to sow very early in hot-beds or greenhouses, the plants being kept under glass until they have formed several clusters of flowers, and perhaps developed a few green tomatoes. (649.) As the plants are tender to frost they should never be planted in the open ground until after danger of injury from this source has passed. The crop should be matured and harvested, if possible, before there is much danger of destructive frosts in the fall.

Sudden changes in temperature are a disadvantage, especially decided drops, because they check growth and may permanently impair the fruiting qualities of the plants. A medium rainfall is essential. The crop fares best when the precipitation is well distributed throughout the season.

646. Soils.—A deep, fertile, sandy loam with a well-drained clay subsoil, undoubtedly provides the best conditions for the culture of tomatoes. The crop, however, is grown successfully on a great variety of soil types. Tracy ("Tomato Culture," p. 33) records: "Of the 10

largest yields of which I have personal knowledge and which ran from 1,000 to 1,200 bushels of fruit (acceptable for canning, and at least two-thirds of it of prime market quality) an acre, four were grown on soils classed as clay loam, two on heavy clay—one so heavy that clay for making brick was subsequently taken from the very spot which yielded the most and best fruit—one on what had been a black ash swamp, one on a sandy muck, two on a sandy loam and one on a light sand made very rich by heavy annual manuring for several years. They were all perfectly watered and drained, in good heart, liberally fertilized with manures of proved right proportions for each field, and above all, the fields were put into and kept in perfect tilth by methods suited to each case."

Sandy soils are, of course, especially desirable for the early crop; they are also injured less by tramping over the ground when gathering the crop in wet weather, and the cost of tillage is not so great as in clay soils. In Indiana (Ind. Sta. Bul. 144, p. 512) "the highest yields are being secured on sandy loam soils well drained, and comparatively rich in plant food. On the heavier soils the yields have not been so large as on the lighter types, although the tomatoes are usually more firm and meaty, which it is considered makes them better adapted for canning. On lighter soils, as a rule, the fruits are more juicy and the meat is less solid." While the sandy types are perhaps preferred in all of the states, large areas are often grown on heavy soils. In any case, however, the drainage must be perfect if large yields are expected. There is abundant evidence that the fruits of many varieties, especially the early ones, are smoother and more symmetrical when grown on sandy soils.

For the early crop, location and exposure should be carefully considered. Protection from the north and west winds is a great advantage and southern slopes favor early maturity.

647. Varieties change so rapidly from year to year that it is scarcely worth while to do more than mention the names of varieties prominent today, but which may not be known 10 years from now. There are exceptions, as the Stone, but the probabilities are that even this standard variety of such splendid qualities will ultimately be replaced by a superior one. Four-fifths of the varieties suggested in this discussion were not offered by American seedsmen 10 years ago. The grower, therefore, should be on the lookout for improved varieties, scanning the catalogs annually and securing sample packets of seeds of the most promising for testing in comparison with the old, reliable sorts.

Some markets have a preference for red tomatoes, while others want purple. Again, it often occurs that there is a demand for fruits of both colors upon the same market.

EARLY VARIETIES

EARLIANA is very much the best-known early variety in America, being grown probably more extensively than all other early varieties combined. Extreme earliness, great productiveness, bright-red color, large size and high quality for an early tomato are the points that have gained for it such wide popularity. As the strains of this variety show great variation too much care cannot be exercised in procuring seed of the best, whether purchased or grown at home.

BONNY BEST, introduced only a few years ago, practically as early as Earliana, is regarded superior by some successful growers. The fruit is red, solid, of good size. The plants are very productive.

CHALK JEWEL has been a most valuable acquisition. It is a week to 10 days later than Earliana, but the plants are stronger and more resistant to blight. The variety is planted extensively in many sections. The fruits are large, red in color and remarkably smooth and uniform in shape.

JUNE PINK is a popular variety for markets which prefer pink tomatoes. It is not so prolific as Earliana.

GLOBE is a purple, medium early variety, valued for its solid globular fruits. While it is exceedingly popular among many growers, it has not met with universal favor; it should, however, be thoroughly tested by every commercial grower.

LATE VARIETIES

STONE takes first place in its popularity among late varieties grown for market or for canning. The plants are strong and vigorous and produce a heavy setting of large, solid, bright-red tomatoes. It is grown almost exclusively for canning.

MATCHLESS is a remarkably fine, late tomato which matures slightly earlier than Stone. The fruits are as solid and as fine in quality. This variety should be chosen for sections where the summer is too cool and too short for the best results with Stone.

DWARF STONE is a favorite with some growers, especially in home gardens, where upright plants are wanted on account of limited space.

CORELESS and **HUMMER** are new varieties gaining in popularity. The fruits are red, globular and solid.

BEAUTY is probably the most largely planted late pink tomato. The fruits color thoroughly over the entire surface. Like other pink tomatoes, the skin cracks badly in wet weather.

TRUCKER FAVORITE, a purple-fruited variety, has been largely planted for many years. The tomatoes are large, solid and of fine quality.

PONDEROSA is a very large, purple-fruited variety, valued by many home gardeners on account of the few seeds and extremely solid flesh. The quality is excellent, but the fruits are often ill-shaped.

648. Seed.—Some of the canning and catsup factories save and place on the market large quantities of seeds which are separated by machines at a small cost and sold to seedsmen at relatively low prices. Seed of this character should never be planted or placed on the market, because there has been absolutely no selection in its production. Breeding plats are maintained by many seedsmen, or contracts are made with reliable and expert growers, in order to secure the best seed for the trade. Excellent seeds of many varieties are obtainable from well-known dealers, although there is an increasing tendency among skillful growers to save their own seed.

649. Starting early plants.

The proper time to sow depends upon: (1) The facilities available for growing the plants; (2) climatic conditions; (3) purpose of the crop; (4) land available; and (5) market conditions. In most instances the tomatoes that ripen first command the highest prices, so that the majority of growers desire to place their product upon the market at the earliest possible date, although they may be unwilling to provide the equipment or to make the expenditure of time



FIG. 106. POT-GROWN
TOMATO PLANT

and money necessary to grow really early tomatoes. It is expensive to grow such plants as shown in Figure 106. The cost and the value of the space which they occupy in frames or greenhouses should always be taken into account in determining profits. An increasing number of gardeners, however, find it profitable to grow extremely early tomatoes. The following plans (there are

many others so far as details are concerned) are in common use:

1. Sow thinly, 6 to 8 weeks before field planting, in hotbed or greenhouse in rows 3 to 6 inches apart, and set in the field without previous transplanting. This plan should not be recommended, because the plants are usually spindly and the root system poorly developed.

2. Sow 10 to 12 seeds to the inch of furrow, rows 2 inches apart, 7 to 8 weeks before field planting; transplant $1\frac{1}{2}$ or 2 inches apart in 3 or 4 weeks from sowing.

3. Sow as directed in No. 2, about nine weeks before field planting; transplant $1\frac{1}{2}$ or 2 inches apart, preferably in the greenhouse; three weeks later, plant 4 x 4 or 4 x 5 inches apart in flats or beds, or in 3 to 5-inch paper or earthen pots, or in veneered boxes or berry baskets. This method with any of its modifications should produce fine plants and meet the requirements when the tomatoes are grown on a large field scale.

4. Sow 10 to 11 weeks before field planting, and make at least three shifts in flats, beds or preferably pots, the space or the size of the pots being increased each time until the plants stand 7 to 10 inches apart. When this method is followed, the crown cluster of flowering buds should be removed as soon as it appears. This will cause the axillary buds and branches to develop rapidly and each to produce a cluster of flowers. The plant will thus have two to five flower clusters instead of one when set in the field. There should be a bountiful supply of ripe tomatoes in 40 or 45 days from the date the plants are set in the field. Ripe tomatoes from plants of this character have been picked in 37 days from the time of planting in the open ground. In many northern markets the tomatoes which are picked soon after July 1 will average about 2 cents each.

Tomato plants should always be grown rather slowly, without check in growth at any time. For a maximum

production of first early fruits, each plant should bear two or more clusters of flowers when set in the field.

650. Starting late plants.—In many of the southern districts where tomatoes are grown for the cannery, the seed is sown in the open, and the plants set in the field when they are 6 to 8 inches tall. In northern sections plants are generally started under glass or protecting muslin or canvas and set in the field with or without previous transplanting. There is an increasing tendency, however, to transplant at least once before taking to the open ground. Both practical experience and experiments indicate that relatively early sowing with at least one transplanting increases yields. The truckers and market gardeners of the North often exercise almost as much care in starting the late plants as the early ones.

651. Soil preparation.—Land manured heavily for a cultivated crop the preceding year should be in prime condition for tomatoes. Heavy clover sods are regarded excellent, especially for the late crop. Green manures are employed extensively in some sections preparatory to planting tomatoes. Whatever the previous treatment of the land has been, early spring plowing and frequent and thorough subsequent harrowing are essential to the best results.

652. Fertilizing.—As soils and methods of soil treatment vary greatly on different farms where tomatoes are grown, it is useless to attempt much more than a general discussion of this subject. There is an antiquated idea that the tomato should not be planted in rich soils. This wrong conception of the needs of the plant has perhaps had its origin in improper methods rather than in actual tests of liberal and intelligent feeding. Every observing grower is familiar with the injurious effects of large amounts of soluble nitrogen, applied late in the season, or of fresh stable manures used shortly before planting. Such treatments, especially if there is

a shortage of the mineral elements, invariably result in a heavy growth of vine and foliage and a light crop of small fruits. While nitrogen is essential, it should be used in moderation. Its value is greatest early in the season, before the organic forms have had time to be changed by nitrification into nitrates. Numerous experiments show the value of spring applications of nitrate for this crop. Such treatment encourages a vigorous vine growth before the fruits begin to color and in most instances has been the means of increasing the yield. Notwithstanding the beneficial results arising from the use of nitrate of soda, it is admitted that part of the nitrogen should be derived from an organic form, as dried blood, tankage and fish scrap. For the late crop the soluble forms of nitrogen are not so useful, and yet in thin soils they may be employed to advantage.

The mineral elements must also be supplied in ample quantities, for without them the fruits will be small and inferior and the crop light. There should be a proper proportion of the three elements applied. This will doubtless vary greatly in different soils, or even on the same type, the amount of each to use depending upon previous methods of cropping and of soil treatment.

A knowledge of the composition of the fruit and the vines assists in the determination of a satisfactory combination of fertilizing ingredients. Voorhees ("Fertilizers," p. 233) estimates a ton of the fruit and vines to contain the following amounts of nitrogen, phosphoric acid and potash:

COMPOSITION OF TOMATOES

	Nitrogen lbs.	Phosphoric acid lbs.	Potash lbs.
In fruit	3.20	1.00	5.40
Vines (green)	6.40	1.40	10.00

He estimates that a yield of 10 tons an acre, with vines

of probably four tons, would contain 57 pounds of nitrogen, 16 of phosphoric acid and 94 of potash.

Because the requirements of soils vary widely, Corbett (Farmers' Bulletin, 220, U. S. D. A., p. 11) recommends the following simple fertilizer test:

Plot 1. Nitrate of soda, $\frac{1}{2}$ pound to 10 plants. Plot 2. Muriate of potash, $\frac{1}{2}$ pound to 10 plants. Plot 3. Phosphate, 2 pounds to 10 plants. Plot 4. Nitrate of soda, $\frac{1}{2}$ pound; muriate of potash, $\frac{1}{2}$ pound to 10 plants. Plot 5. Phosphate, 2 pounds; muriate of potash, $\frac{1}{2}$ pound to 10 plants. Plot 6. Nitrate of soda, $\frac{1}{2}$ pound; phosphate, 2 pounds to 10 plants. Plot 7. Nitrate of soda, $\frac{1}{2}$ pound; phosphate, 2 pounds; muriate of potash, $\frac{1}{2}$ pound to 10 plants. Plot 8. Barnyard manure, 1 shovelful to the plant. Plot 9. Unfertilized. A careful record should be kept of the fruits from each plot.

On thin soils rotten manure is often used. It increases the size and the yield of the fruit. It is frequently applied in hills or furrows.

The most successful growers of early tomatoes use fertilizers carrying about 4 per cent nitrogen and 8 to 12 per cent each of the mineral elements. Amounts vary from 500 to 1,000 pounds an acre. In good soils the percentage of nitrogen may be reduced to 2 per cent. A smaller proportion of nitrogen is generally an advantage for the late crop.

653. Planting.—Tomato plants should be set in the open ground with as little check in growth as possible. If properly grown and hardened, there should be practically no wilting or checking of growth when the transfer is made. Nothing is gained by exposing the plants to cool, frosty nights, for under such conditions they make very little growth, and there is a great risk of serious loss from hard frosts. The plants should be hardened as much as possible before setting in the open ground.

The proper planting distances should be determined by the productiveness of the soil, vigor of the variety to be grown and by the method of culture or system of training to be followed. In thin soils and with early varieties 3 x 3 feet apart will be satisfactory. In many soils 3 to 3½ x 4 feet are good distances for early varieties; 4 x 4 and 4 x 5 feet are common planting distances for late varieties. Even more space is often allowed in soils where a rank growth is secured.

The usual methods of transplanting are employed. In the canning districts transplanting machines are in common use.

654. Cultivation.—Clean tillage is essential to large fruits and high yields. Some hand hoeing is required, although this work will be slight if the plants are set in check rows.

655. Training.—The pruning or training of tomatoes is not generally practiced, except in greenhouse culture, where single-stem training has met with universal favor. This system is also used to some extent in field and garden culture. The advantages claimed for it are: (1) The bulk of the fruit ripens earlier than under natural methods; (2) there is less trouble from various fungous diseases; (3) the fruit is larger and finer in every particular; (4) the fruit is clean when picked, thus the expense of preparing for market is reduced; (5) spraying and cultivation may be continued longer because the vines are not lying prostrate on the ground and interfering with these operations; (6) harvesting is more convenient; (7) on account of earlier maturity the land may be used for a second crop of vegetables, or for a cover crop to be used for manurial purposes.

While the results secured by many practical growers and the rather numerous investigations at the experiment stations support the foregoing arguments for this system, some practical growers are opposed to it and

some tests at the stations are not favorable. The objection usually raised is, the expense of single-stem training. More plants are required to the acre; stakes must be provided, placed, removed after harvest and stored for the next crop; the axillary buds must be pinched out weekly and the plants tied to the stakes. These operations involve considerable labor and no grower should adopt the system unless he is certain of the required labor.

Single-stem training is practiced most extensively in the vicinity of Marietta, O. Probably 500 acres were staked in that region in the summer of 1910. In one field one often sees 20,000 to 30,000 plants, and at the height of the season, 10 or more cars are shipped in a day, all of the crop having been grown by this method. The pink tomatoes—Beauty, Acme, Globe, and June Pink—are the most popular varieties at Marietta. The strong, vigorous plants are set in check rows about 4 feet apart and the plants 30 inches apart in the row, 4,000 to 5,000 plants being generally set to the acre. The stakes are from 1 to 1½ inches in diameter and 5 feet long, and are driven in the ground when the plants are set. They are split by hand from oak, since split stakes are stronger and more durable than sawed ones. The average cost of these stakes at Marietta is about 1 cent each. The plant is tied to the stake as soon as possible after planting. All side buds are nipped as soon as they appear. The plant is nipped when it reaches the top of the stake. It is supported by tying with coarse twine or raffia at four different places.

It is estimated that the average yield in the Marietta region is from 10 to 15 pounds, and that receipts run from 5 to 13 cents a plant. The tomatoes are packed in splint baskets holding 25 to 35 pounds, and shipped in refrigerator cars. Nearly all sales are made through the local association.

Another plan used sometimes, especially when there

is a limited area of land available for this crop, is to plant about 2 x 4 feet apart, drive a strong stake at each plant, and tie up all vines without any pruning. This plan results in a much larger yield to the acre than if this extra work were not done, but the added expense is a very objectionable feature, and the system is seldom used. Various forms of trellises or supports, often used in home gardens, serve to keep the fruit clean and may reduce the percentage of rot.

656. Harvesting.—The proper time of harvesting depends upon various factors, as distance from market, character of the weather and danger of frosts. In the far South, tomatoes are usually picked as soon as they show the slightest change in color. This always results in a sacrifice of quality, because the best flavor is developed when the fruits are permitted to remain on the vine until fully ripe. Even for local markets it is customary to pick the tomatoes before fully ripe, and this is generally necessary in order to have the fruit reach the consumer in solid condition. Tomatoes lose their firmness very rapidly in warm weather, so that it is especially important to guard against this trouble in handling the midsummer crop. When there is danger of destructive autumn frosts the only safe policy is to pick every specimen that shows any change in color. The fruits will continue to ripen in any convenient outbuilding or in the cellar. They also ripen rapidly under hotbed sash or in the greenhouse. Tomatoes should always be handled with the greatest care to avoid bruising.

657. Marketing.—The utmost care should be exercised in preparation for market if highest prices are to be realized. The tomatoes should be cleaned, stems removed and then carefully graded. Packages in great variety are used in handling this crop. The bushel basket is used in Michigan (Figure 46); bushel box at Boston; baskets of various forms and sizes; crates as rep-

resented in Figure 48 being especially desirable for long shipments. Figure 107 shows a package becoming more popular every year. Tomatoes are often wrapped in paper before packing. When grown for canning the ripe tomatoes are picked into crates or baskets and hauled or shipped to the factories without cleaning or further attention.

658. **Yields and returns.**—According to Tracy the average yield of tomatoes grown for canneries (Tracy, W. W., "Tomato Culture," p. 117) probably does not exceed 100 bushels an acre. It is not difficult to produce



FIG. 107. TOMATOES PACKED FOR MARKET

500 bushels on an acre. Yields of 800 are not unusual and even larger crops are frequently reported. The price paid for tomatoes by canning factories ranges from \$7 to \$10 a ton. The expenses of production and delivery to the factories vary so much that any figures which might be given would have very little value. The cost of starting the plants is a factor sometimes. High cost of labor to harvest the crop and a long haul to the factory may reduce the profits to a small margin. With

good management, suitable land, labor at a reasonable cost and fairly close proximity to the factory, a fair profit should be realized at \$9 to \$10 a ton.

When grown for market the profit should not be less than \$100 an acre, and it is often much greater. Market conditions and the skill of the operator are the chief factors counting for success. Early tomatoes often sell at \$2 or more a 6-basket carrier, while late in the season the price may become so low that it scarcely pays to harvest the crop. As a rule, the early crop is the more remunerative, while late tomatoes frequently pay good profits.

659. Insects.—Cutworms are often destructive to the young plants. Surplus stock should be grown and held to fill vacancies that may occur from the depredations of these pests. Poisoned baits of bran, clover, weeds and other vegetable matter are usually effective when placed about the plants. Flea-beetles are also serious enemies sometimes.

660. Diseases.—The tomato is subject to various diseases, which often become serious. Rotation is the best means of prevention. Spraying with bordeaux mixture in the seed bed, and also after transplanting in the frames or the greenhouse, and in the garden or field, is frequently necessary to control the various fungous diseases.

TURNIP (*Brassica rapa*)

661. History and importance.—This cruciferous vegetable originated in Europe or Asia. When planted early in the spring it is an annual, but when grown in the fall the roots must be stored during the winter and replanted the following spring for the production of seed. It is one of the most important of the root crops, grown extensively as a fall crop and to some extent for early summer use.

662. Soil.—Like other root crops, the finest specimens are grown in sandy soils, although the crop is produced

in a wide range of soil types. To secure large yields and high quality it must be fertile and constant in supply of moisture until the roots have attained a marketable size.

663. Climate.—The turnip thrives best in a cool, moist climate. As only 6 to 8 weeks are required from seed sowing till maturity, it may be grown successfully in the most northern cultivated sections. The leaves are hardy and the roots may be left unprotected in the open ground until there is danger of hard freezing weather.

664. Varieties.—White-fleshed varieties are in most common use although the yellow-fleshed sorts are preferred by some. In shape the roots are oblate, oval, spherical or conical. Formerly the flat varieties were generally grown, but the markets now prefer the more spherical forms. Some of the most popular varieties in cultivation are WHITE MILAN, RED or PURPLE TOP (Strap Leaf), WHITE FLAT DUTCH (Strap Leaf), PURPLE TOP WHITE GLOBE, WHITE EGG and YELLOW GLOBE.

665. Seed Sowing.—For the early crop, sow the seed as soon as the ground can be prepared; for the late crop, sow in the latter part of July or early in August, depending upon locality. The rows may be 12 to 18 inches apart if a wheel hoe is to be used in cultivating, and 26 to 30 if a horse cultivator is to be employed. The tendency is to sow the seed too thickly, and thus necessitate a large amount of labor in thinning. If one good seed is dropped to every inch of furrow the stand should be satisfactory; even then thinning will be required. For the early crop the plants should be about $2\frac{1}{2}$ to 3 inches apart, while for the larger late varieties 4 or 5 inches between plants in the row will not be too much space. The seeds should be planted from $\frac{1}{2}$ to $\frac{3}{4}$ inches deep. For the late crop the seed is often sown broadcast in well-prepared soil, and then raked in very lightly. This is a favorite plan on general farms, where roots are wanted for stock feeding and also for the home table.

When roots of uniform size and high quality are desired for market, it is much better to sow in drills, so that cultivating, weeding and thinning can be properly attended to.

666. Fertilizing.—See notes for beets (323).

667. Harvesting.—See notes for beets (325).

668. Enemies.—Club root is the most serious disease. See notes on club root of cabbage (367). Maggots are also destructive sometimes. The application of carbolic acid emulsion is the most effective treatment (133). The emulsion is injected into the soil about the roots. This is rather tedious and expensive to practice on a large commercial scale. Turnips should always be grown in rotation with the noncrucifers to avoid losses from the attacks of insects and diseases.

WATERMELON (*Citrullus vulgaris*)

669. History.—The watermelon is native to Africa and has been cultivated since remote antiquity. Although a popular dessert vegetable in many parts of the world, it has met with greatest favor in the United States.

670. Importance.—The watermelon is an important crop in every southern state and from some sections of the South it is shipped north in enormous quantities. Arizona and other western states are developing the industry. All of the northern states produce this cucurbit to some extent. It might be grown more largely, however, in the less favorable parts of the country were proper cultural methods adopted.

671. Varieties.—Rane (N. H. Sta. Bul. 86, p. 95) prepared a system of classification which should be familiar to students of vegetable gardening. The analytical key contains the following six classes, according to the color or markings of the skin: (1) Light Green Class, (2) Medium Green Class, (3) Dark Green Class, (4) Light

Striped Class, (5) Dull Striped Class, and (6) Mottled Green Class. Each class is divided into two or three types. Many distinct varieties are offered by our seedsmen, the following being largely planted:

KLECKLEY SWEET or **MONTE CRISTO**, exceedingly popular in many melon-growing districts, is a large, oval, dark green, somewhat mottled, melon of superior quality.

KOLB GEM is a favorite bright-red fleshed melon highly valued for commercial purposes.

CUBAN QUEEN is a large melon which has been extensively grown for many years.

HALBERT HONEY is a large, attractive, sweet, tender sort, popular wherever it is known.

DIXIE is an early, productive variety of good quality.

SUGAR STICK is a large, light-green melon of handsome appearance, fine flavor and of excellent shipping qualities.

COLE and **FORDHOOK** are very early varieties and popular in northern districts where climatic conditions are not favorable for melon culture.

672. Climate.—The watermelon thrives best in the South, where the seasons are long, the day and night temperatures high, and where frost seldom interferes with the progress of the young plants or the ripening of the fruits. The watermelon is more sensitive to cold than the muskmelon. Most of the varieties require a longer season in which to mature. While this vegetable demands heat, sunshine and a long summer, it may be grown and is produced successfully in the North when proper cultural conditions are provided.

673. Soil.—A sandy soil well adapted to muskmelons (510) is equally suitable for watermelons. A sandy top soil with a well-drained subsoil is considered ideal.

674. Seed.—The most successful growers are very particular in regard to the character of the seed which they use. Breeding plats are sometimes maintained, because

it is important to take the plants as well as the individual melons into consideration. It is desirable to discard the seeds at the stem and the blossom ends of the melon, because they are not so mature nor so well developed. The seed is often kept four or five years, so that it is unnecessary to grow and save seed annually.

675. Starting early plants.—Watermelon seed is usually planted in the open ground where the crop is to mature. In northern districts, however, the plants are sometimes started under glass as described for cucumbers (436) and for muskmelons (512).

676. Soil preparation.—The soil must be well supplied with humus, although an excessive amount may cause too much vine growth at the sacrifice of fruit. The methods of soil preparation are practically the same as for muskmelons (513).

677. Fertilizing.—See notes (514) on fertilizing muskmelons.

678. Planting.—See notes (515) on planting muskmelons. Where soil is rather poor, watermelons may be planted in hills, 8 x 8 feet apart; but the more common distance is 10 x 10 feet, while in rich soils the hills are often 12 x 12 feet. The seeds are sometimes planted in drills as explained for muskmelons (515), but more space is allowed between the plants in the row.

679. Cultivation.—See notes (516) on cultivating muskmelons. Always stir the soil about the plants in the hills after hard rains, which may incrust the surface.

680. Harvesting and marketing.—It is exceedingly important that every melon be sent to market at the proper stage of ripening. If it is underripe, quality will be sacrificed, and if overripe it will not carry well on wagons or cars, and the quality will also be inferior.

Experience counts for more than anything else in enabling one to determine the proper time to pick melons. Many people who live in melon districts and have helped

to harvest the crop for a number of years can invariably tell when a melon is ripe, but they are unable to explain how they know. The sound emitted when the melons are "thumped" is the most reliable means of determining the state of ripeness. Regarding this matter the Georgia Station (Ga. Sta. Bul. 38, p. 76) calls attention to the advice of the old negro "mammy" in the ballad, when she berated her grandson for stealing a green melon: "Be shore, when you thumps 'em dey allus soun' 'plunk.'" The Arizona Station (Circular 44) writes: "Most varieties give forth a distinctly different sound when ripe and when green. The greener the melon, the sharper and more metallic is the ring that it gives forth if snapped with the finger. As the melon matures and becomes less solid, it gives forth a somewhat hollow and distinctly muffled ring. The riper the melon, the more nearly the sound given will be like that produced when the palm of the hand is snapped with the finger. Some varieties will be ready for market, while the melons still give forth a somewhat metallic sound, while others must be left on the vines until the sound is quite a 'dead' one. These are matters that can soon be learned by experience. The writer knows by long experience that if proper precaution is taken and a doubtful melon cut occasionally, there is little excuse for ever putting a green melon upon the market."

The test of the tendril (the melon being considered ripe when the tendril is dead) is unreliable. When the underside of the melon "begins to turn yellowish and becomes rough, pimply or warty, with the surface sufficiently hard to resist the fingernail when scratched, it is usually a fair sign of ripeness."

Watermelons are shipped in bulk in box cars, which are bedded with straw. They are usually loaded four deep in the cars and the freight paid according to weight. The following table shows the number of

melons of different sizes that can be loaded on a car (Ind. Sta. Bul. 123, p. 17) :

Car 34 feet long loaded
4 deep contains:

Car 36 feet long loaded
4 deep contains:

Melons	Averaging about (lbs.)	Melons	Averaging about (lbs.)
800	35	850	35
850	32	900	32
900	30	950	30
950	28	1005	28
1000	27	1060	27
1050	26	1110	26
1100	25	1165	25
1150	24	1220	24
1200	23	1275	23
1250	22	1330	22
1300	21	1380	21
1350	20	1440	20
1400	19	1485	19
1450	18	1530	18
1500	17	1610	17
		1700	16

681. Enemies.--See notes on muskmelons (519, 520).

CHAPTER XXII

CROP ROTATION

682. The necessity.—Crop rotation has long been recognized as a necessity. Its value has been more evident, perhaps, in the production of cereals and the general farm crops than in vegetable growing, but it is scarcely less important. Numerous examples might be cited of decline in yields and quality, due primarily to the failure to rotate. In some instances entire communities have been forced practically to abandon the culture of a certain crop mainly because of its continuous or too frequent production.

683. Relation to food supply.—Plants differ greatly in their food requirements. Some utilize large amounts of nitrogen, while others must have liberal supplies of the mineral elements. Crops which have about the same food requirements should not be planted consecutively, if it can be avoided. When cabbage follows cabbage, or lettuce follows lettuce, a heavy draft is made upon the supply of nitrogen. If, instead, these crops were followed by tomatoes the food supply would be utilized more economically, successful crop production would be more certain and the yielding power of the soil would be conserved to better advantage. Many examples might be given to illustrate this point. While this principle should always be considered, certain conditions, as the use of muck soils or the accessibility of cheap supplies of manure, may justify a system of cropping which would not be permissible under other circumstances.

684. Relation to humus.—Crops differ widely in their ability to supply humus to the soil, and therefore to change the physical as well as the chemical properties

of the soil. Some crops, as bunch onions, spinach and lettuce, leave practically no refuse on the ground, while others, as turnips, beets and potatoes, furnish considerable quantities of vegetable matter. Another class of plants, the legumes, serve as nitrogen traps, in addition to supplying humus of the most valuable character. The leguminous plants, however, vary greatly as soil improvers. The manurial crops as the clovers, vetch and cowpeas, have already been considered, but field and garden types of peas and beans deserve greater consideration in crop rotations because of their value as soil improvers.

685. Relation to toxics.—Experiments made by the United States Department of Agriculture indicate that the roots of plants (at least of some species) exude toxics or substances which may not be injurious to other plants, but are poisonous to themselves. While there is no proof that this is true concerning vegetables, it is probable, and the principle should be regarded when planning rotations for all types of vegetable gardening.

686. Relation to insects and diseases.—Numerous allusions have been made on preceding pages concerning the importance of rotation to avoid losses from the ravages of insects and plant diseases. A multitude of insects and disease spores pass the winter in the ground or are protected by refuse on the surface. If the host plants are grown annually these pests are likely to become more and more destructive. This is one of the strongest arguments for crop rotation in vegetable gardening. Ordinarily, three to five years should elapse between crops of the same species, although less time is sufficient in many instances.

687. Relation to other factors.—Several additional factors should be taken into account, as the profits of the various crops that might be grown, crop adaptation, and the physical and chemical properties of the soil.

688. **Examples.**—It is common for truck crops to be included in a three or four-year rotation with general farm crops. Sweet corn, cucumbers, squashes, early and late cabbage or cauliflower often follow clover in either a three or four-year rotation which, in the North, frequently includes wheat. In trucking districts, where the general farm crops are not grown to any considerable extent, the practice varies considerably. When climatic conditions permit, a winter cover crop should be started on all cultivated areas (unless a cash crop, as spinach or cabbage, is to be planted in the fall and marketed in the spring), and this will be valuable from the standpoint of rotation.

CHAPTER XXIII

SUCCESSION AND COMPANION CROPPING

68g. Succession cropping.—Market gardening and home vegetable gardening are necessarily intensive forms of cropping. The work should be planned so that there will be no loss of space nor loss of time. Maximum yields and maximum returns are the chief aims. One crop follows another in quick succession. In the North, for example, lettuce may be planted a foot apart each way as early in the spring as the ground can be prepared. Strong plants should attain a marketable size in five weeks, when the crop should be promptly sold and summer radishes sown. After four or five weeks the ground is again vacant and a third crop, perhaps snap beans, started. In the most favorable sections the beans would be sold in time to grow winter radishes or a winter cover crop. Plans for succession cropping are numerous. The foregoing is merely an example of many plans used in various parts of the country. Soils, climate, markets and labor conditions must be considered when making plans for succession cropping.

69g. Companion cropping.—When two or more crops are grown together the system is known as companion cropping, intercropping, or double cropping. The plan usually embraces succession cropping. Three vegetables, as cabbage, lettuce and radishes, may be started early in the spring at the same time. The radishes will mature and be removed first. After the removal of the lettuce, the cabbage will have entire possession of the ground; then, beans may follow the cabbage. This is simply an example of the many plans for companion cropping.

Companion cropping has advantages as well as disadvantages. The advantages are, (1) economy of space, no ground being wasted; (2) economy of plant food, the surplus applied for one crop being utilized by another; (3) economy in tillage, the same plowing, harrowing and cultivation serving for two or more crops; (4) concentration of operations, the force of laborers being confined to one acre instead of two or three; (5) soil improvement, as when peas or beans are planted with other crops; (6) increased profits from the area cultivated.

The disadvantages are, (1) the necessity for an increased amount of hand labor in weeding and the use of hoes and hand wheel hoes; (2) a greater demand or requirement for plant food and soil moisture; (3) the close attention and time required in looking after the details. For these reasons many commercial gardeners prefer to cultivate more acres, with perhaps less annoyance. Some plans of double-cropping, however, are no more troublesome than of single cropping.

Companion cropping is most advantageous under the following conditions: (1) When the area of ground available is very much limited; (2) when land values, rentals and taxes are high; (3) when liberal supplies of manure are easily available; (4) when the necessary labor can be secured without much difficulty; (5) when good markets are easily accessible; (6) when irrigation is possible or when the soil moisture can be readily conserved.

In making specific plans for companion cropping the following factors should be carefully considered: (1) The time when each crop will be planted. (2) The time when each crop will mature. (3) The required space for each vegetable at various stages of growth. (4) The habit of growth of the various plants. (5) The supply of soil moisture and plant food in their relation to time of maturity and the space required.

691. **Plans for companion cropping.**—Numerous plans of intercropping are in use among vegetable gardeners. Those described on the following pages are in common use or have been found highly satisfactory by successful gardeners.

1. EARLY CABBAGE (C), and LETTUCE (L).

14"	C 9"	L 9"	C	L	C	L	C
14"	L	L	L	L	L	L	L
	C	L	C	L	C	L	C

The plants are started under glass and set as early as possible in the open. Lettuce should be large enough to cut in five weeks.

2. EARLY CABBAGE (C), LETTUCE (L), and RADISH.

9"	C	L 9"	C	L	C	L	C
9" radish						
	L	L	L	L	L	L	L
 radish						
	C	L	C	L	C	L	C

Three crops planted early in the spring. Cabbage and lettuce are started under glass. Button radishes will mature in 3 or 4 weeks, lettuce in 5 weeks and cabbage in about 10 weeks. This is a very popular plan, yielding large returns an acre under favorable conditions. A good market must be assured.

3. EARLY CABBAGE (C), HORSE-RADISH (H), and LETTUCE (L)

13"	C	H 8"	C	H	C	H	C
	L	L	L	L	L	L	L
	C	H	C	H	C	H	C

Three crops planted early in the spring. In hoeing and cultivating the cabbage and lettuce no attention is paid to the horse-radish. Deep, rich soil is required. If more space is allowed, the radish may be planted between the rows, as indicated in plan No. 2.

4. EARLY CABBAGE (C), BEETS, ETC.

14"	C 14"	C	C	C
	Beets	
14"	C	C	C	C

Both crops planted early in the spring. Transplanted beets may be used or seed sown. Early turnips, carrots, bunch onions, spinach, mustard and other small, early maturing crops may be substituted for the beets.

5. LETTUCE and BEETS.

6"	Lettuce
	Beets
	Lettuce

The lettuce may be transplanted or sown in early spring. When it is nearly ready to harvest, beets may be drilled between the rows. Radish, lettuce, carrot and other small crops may be substituted for beets. As

each crop approaches maturity another crop is started. This plan is popular with many gardeners on Long Island.

6. RADISH and CARROT.

 Radish
8" Carrot
 Radish

Both crops are sown early. The radishes will mature first. Parsnip, salsify, swiss chard, beet, kohl-rabi, turnip or spinach may be substituted for the carrot.

7. BEET and HORSE-RADISH

 Beet and horse-radish.....
14" Beet
 Beet and horse-radish.....

Beets are sown early. The horse-radish is planted with bar or dibber as soon as the beets are up.

8. PEAS and RADISH.

 Pea
10" or 12" Radish
 Radish
 Pea

Half-dwarf peas and an early maturing radish may be used if desired. Both crops are planted early. Dwarf peas may be planted 24 inches apart with a row of rad-

ish between. Early beets, bunch onions, early carrots and early turnips may be substituted for radish, but the spacing should be more liberal. Any of these crops will mature in time to grow a fall crop of carrots, turnips, lettuce or perhaps beans.

9. BEET and LATE CABBAGE.

 Beet and cabbage
2' Beet
 Beet and cabbage

Sow early beets in May with rows as straight as possible. Cultivate with a horse. At the proper time, remove enough beet plants at intervals of 20 inches in alternate rows to set late cabbage plants. Any small early maturing crop may be substituted for beets.

10. PARSNIP, LETTUCE AND RADISH.

 Parsnip and lettuce
12" Radish
 Parsnip and lettuce

Seed of all these crops is sown early. After the radishes are sold, use horse cultivator. Care is required in cutting lettuce to avoid injury to parsnip.

11. RADISH AND CARROT. A Wisconsin grower sows early radish and carrot seed together in the same row. The radishes are removed before there is much injury to the carrot plants. Radish seed may also be used in the same way with salsify and parsnips.

12. TURNIP AND RADISH.

10" Turnip
 Radish
 Turnip

Both crops are sown early. The radishes will mature first.

13. ONIONS AND CELERY.

12" Onions
 Onions
12" Onions
 Onions
	... Celery after bunch onions ...

This plan has been used extensively on muck soils in the growing of the green varieties of celery. Late celery is planted in every fifth row after the onions in that row are large enough to bunch. The other four rows are permitted to mature. When an early variety of celery is planted and boards are used for blanching, the celery rows need not be more than 2 feet (or less) apart. Then it will be possible to plant only one row of onions between the celery.

13. RADISH AND EARLY CELERY.

12" Radish
 Radish followed by celery
 Radish

A very early variety of radish should be used so the roots will mature before it is time to plant early celery.

14. ONIONS AND ASTERS.

14"
 Onions
 Onions and asters
 Onions

A Wisconsin florist uses this unique plan. White Portugal onion seed is sown early to produce bunching onions. When there is no further danger of frost, asters are set 2 feet apart on the side of alternate rows. The onions are sold before there is any injury to the asters.

15. ONIONS AND CUCURBITS. Onions may be planted in rows a foot apart. At the proper time, plant muskmelons in every sixth row, or watermelons in every ninth row, or squashes every tenth or twelfth row, and space in the row as may be desired.

16. LETTUCE AND CELERY

12"
 Lettuce
 Lettuce
 Lettuce
 Lettuce
 Lettuce and celery

Soil should be very rich. Strong plants of lettuce are planted as soon as possible. Every fifth row is removed for early celery, or it may be possible to sell all the lettuce, and intercrop with beets, turnips or other small, quick-maturing vegetables.

17. TOMATOES AND STRAWBERRIES.

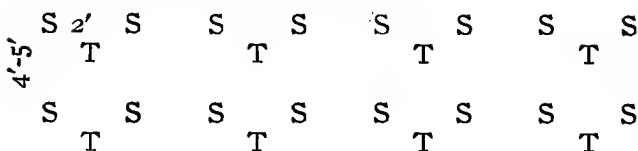

Strawberries, planted in the spring as soon as the ground is dry enough; tomatoes (for the late crop), planted in June. Used successfully by some New Jersey growers. It is claimed that the tomatoes do well and that the yield of strawberries the following season is not affected.

18. BEANS AND STRAWBERRIES.

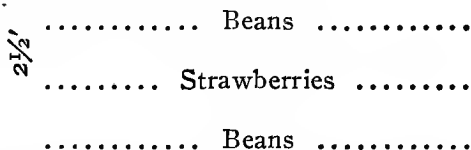

The strawberries are planted early and bush beans at the proper time. This is a popular system at Norfolk, Va. After selling the snap beans the plants are plowed into the soil. Strawberries are grown in wide mat rows.

19. SWEET CORN AND LATE SQUASH. Early corn is planted in rows 2 1/2 feet apart. Every sixth row is left vacant and planted with squash. Watermelons may be substituted for squash. The corn fodder, after marketing the ears, is cut and shocked.

20. BEANS AND CUCUMBERS.

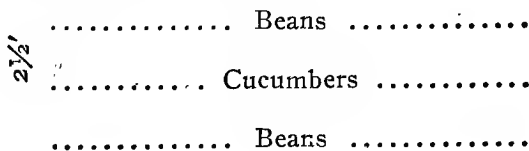

Do not plant bush beans closer than 1 foot from the muskmelons. Two hills of pole beans may be substituted for the muskmelons. Bush beans may be planted two weeks earlier than melons.

29. CORN AND BEANS. A New Jersey grower plants two or three beans with each grain of corn. The beans are marketed first and the yield of corn is apparently not affected.

30. PEACHES AND TOMATOES. Tomatoes are grown extensively in the young peach orchards on the eastern shore of Maryland.

31. APPLES, PEAS AND TOMATOES. A New Jersey grower plants early peas in his young apple orchards. The peas are followed by tomatoes, and crimson clover is sown at the last cultivation of the tomatoes.

32. CABBAGE AND TOMATOES.

$2\frac{1}{2}'$ Cabbage
 Tomatoes
 Cabbage

Midsummer varieties of cabbage, planted early; late tomatoes, planted in June or earlier if climate requires earlier planting.

33. FRUIT TREES AND PEAS AND BEANS. An excellent combination for young orchards is to plant peas early in the spring and follow with bush beans. The beans should be sold in the pod or allowed to ripen for dry shell beans.

34. POLE BEANS (B), AND RADISH.

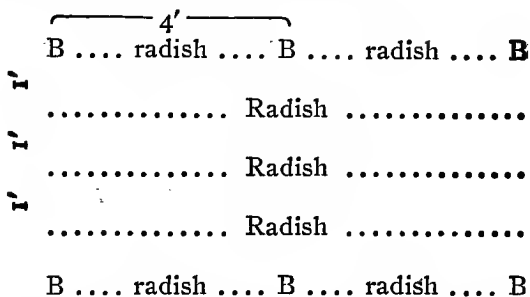

This is a successful plan of cropping in Philadelphia County, Pa. Both crops are started at the same time.

35. SWEET CORN AND RADISH.

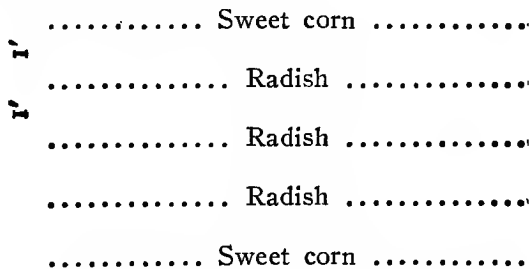

Radish may be planted first or both started together.

36. PARSNIP AND SPINACH.

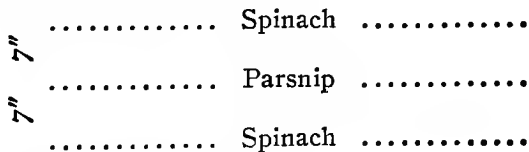

Both crops planted early.

37. BEANS AND LETTUCE.

10" 10" Early bush beans
 Lettuce
 Lettuce
 Early bush beans

Lettuce started under glass.

38. CABBAGE (C), AND STRAWBERRIES (S).

2 1/2'	C	S 9"	C	S	C	S	C
	C	C	C	C	C	C	C
	C	S	C	S	C	S	C

This is a popular system at Norfolk, Va.: Early cabbage, planted very early in the spring or on the side of a ridge in the fall; strawberries, planted as soon as possible in the spring. Planting distances vary.

39. BEANS AND CUCUMBERS.

26" 26" Beans
 Beans
 Cucumbers
 Beans
 Beans

Planting distances are variable. Early bush beans are preferred.

Many other combinations of succession and companion cropping might be described, but it is hoped that the foregoing will be at least suggestive to those whose conditions are favorable for intensive types of gardening. This type of gardening appeals to owners of town and city lots and to commercial growers whose areas are limited. It necessarily involves a larger amount of hand work, and for this reason companion cropping is seldom practical where there is difficulty in securing laborers.

CHAPTER XXIV

THE HOME VEGETABLE GARDEN

692. Importance.—The home vegetable garden is an important feature on practically every American farm. Thousands of village people devote part of their lots to the growing of vegetables for the family table, and a host of people in the suburbs of cities grow at least a portion of their own vegetables. The value of the products grown in the kitchen gardens of the United States amounts to millions of dollars annually. Intensive methods are generally employed, so that the returns for the area cultivated are much larger than from general farming or even from truck farming.

The home garden, however, has other values besides those of a monetary character. It has been termed the "farm drug store." A diet of clean, fresh vegetables counts for good health. There can be no dispute on this point. Again, many a weary business or professional man or a tired housekeeper has found pleasure, comfort and health in the care of a garden. When the work is properly managed, it is equally attractive to boys and girls. The cultivation of vacant lots by the youth in our towns and cities should receive every possible encouragement.

693. Aims.—In planning for the home garden the following definite aims should be kept in mind: (1) The production of a liberal, uniform and constant supply of vegetables preferred by members of the family for whom they are grown. (2) Quality is even more important than in commercial gardening. (3) There should be as great variety as possible. The tendency is to restrict the plantings to the most common vegetables. This

plan should be broadened so that crops less generally grown could be used to enhance the value of the garden.

694. Location.—In the selection of a location the following factors should be considered: (1) The home garden should be at a convenient distance from the dwelling, for much of the work will be done at odd times; supplies must be gathered daily or several times a day; the garden, when properly handled, is attractive. For these and other reasons, it is desirable to have the garden near the house. (2) A sandy loam is preferred, but any soil may be improved so that it will produce good results. (3) Thorough drainage is essential. (4) A gentle slope to the south is preferable to any other slope. (5) There should be protection, natural or artificial, from north and west winds. A hedge or a grove is ornamental. (6) Close proximity to a supply of water is a great advantage. Water is often needed at seed sowing, transplanting time or for sprinkling. If possible, every home garden should be provided with an above-ground system of watering. See Chapter VIII. (7) The shade of trees or buildings should be avoided.

695. Varieties.—In the selection of varieties, quality should have first consideration. Vegetables differ greatly in this respect. For example, when one becomes accustomed to Golden Bantam sweet corn there is no desire for the larger, coarser and more insipid varieties. Plant the best for the home table, although it may mean a sacrifice in yield. The time required for various varieties to attain maturity is also worth considering. Again, the vigor or size of growth must be known to determine proper planting distances. The home gardener derives much pleasure in testing the more promising novelties from year to year.

696. The use of glass.—There should be ample equipment in the way of hotbeds and cold frames. A small greenhouse is very useful in starting early plants, and

may also be used in forcing crops to maturity during the winter season. See Chapters XI, XII and XIII for information on these subjects.

697. Management.—High fertility and frequent tillage are essential to success in home vegetable gardening. The plot devoted to this work should receive annual dressings of stable manure at the rate of 25 to 50 tons an acre. Rotten manure will be most satisfactory, although fresh manure may be applied before plowing, except for tomato, pepper, eggplant, the cucurbits and the root crops. If manure is used freely enough there will be little necessity for the employment of commercial fertilizers, although these can often be used advantageously in home garden work. Nitrate of soda should be kept on hand for topdressing about growing plants. A complete fertilizer containing about 4 per cent of nitrogen, 8 per cent phosphoric acid and 10 per cent potash will be beneficial under most conditions.

Special attention is usually given to cultivation, hoeing and weeding. A hard surface crust should not be allowed to form, and tillage between the plants should be so thorough that weed seeds will not be permitted to complete germination. Fall plowing is an advantage in some heavy soils. When deferred until spring, plowing should be done at the earliest possible date, so that there will be no delay in starting early crops. A soil deeply and thoroughly fined is essential to complete success.

698. Plans.—Economy of labor is one of the most important considerations in making plans for the home garden. The old-fashioned garden, where everything is planted in beds between boarded walks, requires a maximum amount of labor. This plan should not be used unless in the very small plats of town or city. It is much better to plant all classes of vegetables in rows, running lengthwise of the plat. On farms, where there is plenty of available land, the rows should be far enough

apart to use a horse cultivator, although some of the smaller vegetables might be planted closer and cultivated with a wheel hoe. Where the area is limited, close planting is necessary, but the rows should seldom be so close as to prohibit the use of hand wheel hoes. This type of tool is not as generally used in home gardens as it should be.

Rotation should be practiced as much as possible in home gardening. It may be the means of avoiding losses, especially from diseases. A change of location, however, is often necessary for the successful cultivation of crops subject to the most serious forms of plant diseases.

There must be more or less succession cropping (Chapter XXIII) in all well-managed gardens. Many crops as pea, radish, beet, bunch onions and spinach are planted very early in the spring and are harvested in ample time to plant the same ground in late crops, such as sweet corn, cabbage, cauliflower, beans, turnips and many other vegetables. Some vegetables, as parsnip and salsify, require a full season, and this must be taken into account when making plans. Companion cropping (Chapter XXIII) is very useful when the plat is small. It makes possible the securing of a much greater variety of vegetables than is ordinarily grown on small areas.

Small fruits and the perennials, as rhubarb, horseradish and asparagus, should be at one side of the garden, so that they will not interfere with plowing and harrowing.

CHAPTER XXV

TABLES

699. Vitality of seeds.—See page 102.

700. Percentage of germination.—See page 101.

701. Number of plants required to the acre at various distances:

1 in. x 10 in.—627,269.	18 in. x 2 ft.— 14,520.
1 in. x 12 in.—522,720.	18 in. x 30 in.— 11,616.
2 in. x 10 in.—313,632.	18 in. x 3 ft.— 9,680.
2 in. x 12 in.—261,360.	18 in. x 4 ft.— 7,260.
3 in. x 12 in.—174,240.	18 in. x 5 ft.— 5,804.
4 in. x 12 in.—130,680.	2 ft. x 2 ft.— 10,890.
6 in. x 12 in.— 87,120.	2 ft. x 3 ft.— 7,260.
12 in. x 12 in.— 43,560.	2 ft. x 4 ft.— 5,445.
12 in. x 15 in.— 34,848.	2 ft. x 5 ft.— 4,356.
12 in. x 18 in.— 29,040.	3 ft. x 3 ft.— 4,840.
12 in. x 24 in.— 21,780.	3 ft. x 4 ft.— 3,630.
12 in. x 30 in.— 17,424.	3 ft. x 5 ft.— 2,904.
12 in. x 3 ft.— 14,520.	4 ft. x 4 ft.— 2,722.
12 in. x 4 ft.— 10,890.	4 ft. x 5 ft.— 2,178.
12 in. x 5 ft.— 8,712.	5 ft. x 5 ft.— 1,742.
15 in. x 18 in.— 23,232.	5 ft. x 6 ft.— 1,452.
15 in. x 2 ft.— 17,424.	6 ft. x 6 ft.— 1,210.
15 in. x 3 ft.— 11,619.	6 ft. x 7 ft.— 1,037.
15 in. x 4 ft.— 8,712.	6 ft. x 8 ft.— 907.
15 in. x 5 ft.— 6,969.	7 ft. x 7 ft.— 888.
18 in. x 20 in.— 17,424.	8 ft. x 8 ft.— 680.

702. Quantity of seed required an acre:

ASPARAGUS, 2½ ounces to 100 feet of drill; 2 pounds should produce enough roots to plant an acre.

BEANS, dwarf, 1 quart to 100 feet of drill; 1¼ bushels an acre. Lima, ¾ bushel to an acre. Pole, 1 pint to 100 feet drill; ½ bushel an acre.

BEET, 1 ounce to 50 feet of drill; 4 pounds to an acre.

BROCCOLI, 1 ounce to 300 feet of drill; 2 ounces an acre.

CABBAGE, 1 ounce to 300 feet of drill; hotbed or greenhouse 1 ounce should produce at least 2,000 plants; outdoors, 1 pound should produce at least 20,000 plants.

CARROT, 1 ounce to 100 feet of drill; $2\frac{1}{2}$ pounds to an acre.

CAULIFLOWER, 1 ounce should produce 3,000 or more plants.

CELERY, 1-3 ounce to 100 feet of drill; 1 ounce should produce at least 10,000 plants.

SWEET CORN, $\frac{1}{4}$ to $\frac{1}{2}$ pint to 100 hills; when planted in hills 1 peck to an acre.

CUCUMBERS, 1 to 2 ounces to 100 hills; 1 to 2 pounds to an acre.

EGGPLANT, 1 ounce should produce 1,500 to 2,000 plants.

ENDIVE, $\frac{1}{4}$ ounce to 100 feet of drill; $4\frac{1}{2}$ pounds an acre.

KALE, 1 ounce to 300 feet of drill.

KOHL-RABI, 1 ounce to 300 feet of drill; 4 pounds an acre.

LEEK, 1 ounce to 100 feet of drill; 4 pounds an acre.

LETTUCE, $\frac{1}{4}$ ounce to 100 feet of drill; 3 pounds to an acre.

MUSKMELON, 2 ounces to 100 hills; 4 x 4 feet, 2 pounds to an acre.

ONION, seed, $\frac{1}{2}$ ounce to 100 feet of drill; 4 to 5 pounds an acre. Sets, 1 quart to 40 feet of drill; 8 bushels, and more if large, an acre.

PARSLEY, $\frac{1}{2}$ ounce to 100 feet of drill; 3 pounds to an acre.

PEAS, 1 to 2 pints to 100 feet of drill; $1\frac{1}{2}$ to $2\frac{1}{2}$ bushels an acre.

PEPPER, 1 ounce should produce 1,500 plants.

RADISH, 1 ounce to 100 feet of drill; 10 to 12 pounds an acre.

RHUBARB, 1 ounce of seed to 125 feet of drill; $3\frac{1}{2}$ pounds to an acre.

SALSIFY, 1 ounce of seed to 100 feet of drill; 8 pounds to an acre.

SPINACH, 1 ounce to 100 feet of drill; 8 pounds to an acre; broadcast, 30 pounds to an acre.

SQUASH, summer, 4 ounces to 100 hills. Fall and winter, 8 ounces to 100 hills.

TOMATO, 1 ounce of seed should produce 3,000 to 4,000 plants.

TURNIP, 1 ounce to 200 feet of drill; 1 to 2 pounds to an acre.

WATERMELON, 1 ounce to 30 hills.

703. Weight of one quart of seeds and number of seeds in one ounce :

Kind of Seed	Weight of a Quart of Seed in Ounces	Number of Seeds in One Ounce
Asparagus -----	32	1,500
Balm -----	20	56,500
Basil -----	20	22,500
Bean -----	24 to 33	200 to 250
Beet -----	10	1,500
Borecole, or kale -----	25	8,500
Broccoli -----	25	10,500
Cabbage -----	25	8,500
Caraway -----	15	10,000
Carrot, with spines -----	9	20,000
Carrot, without spines -----	13	27,000
Catmint -----	28	3,500
Cauliflower -----	25	10,500
Celery -----	17	71,000
Chicory -----	14	20,000
Cress, American -----	20	17,000
Cress, common garden -----	28	13,000
Cress, water -----	20	113,500
Cucumber, common -----	18	1,000
Cucumber, prickly fruited gherkin -----	20	4,000
Dandelion -----	9	34,000 to 42,500
Dill -----	11	25,500
Eggplant -----	18	7,000
Endive -----	12	18,000
Kohl-rabi -----	25	8,500
Leek -----	20	11,500
Lettuce -----	15	23,000
Maize or Indian corn -----	23	100 to 150
Marjoram, sweet -----	20	113,500
Marjoram, winter -----	24	340,000
Martynia -----	10	600
Muskmelon -----	13	1,600
Okra -----	22	425 to 500
Onion -----	18	7,000

Kind of Seed	Weight of a Quart of Seed in Ounces	Number of Seeds in One Ounce
Pea -----	25 to 28	50 to 150
Pea, gray or field -----	21 to 28	150 to 250
Parsnip -----		7,000
Pepper -----	16	4,500
Pumpkin -----	9	100
Radish -----	25	701,000
Rampion -----	28	3,500
Rhubarb -----	3 to 5	1,500
Sage -----	19	7,100
Salsify -----	8	3,000
Savory, summer -----	18	42,500
Savory, winter -----	15	71,000
Spinach, prickly seeded -----	13	2,500
Spinach, round-seeded -----	14	3,500
Spinach, New Zealand -----	8	280 to 350
Squash, Hubbard -----	14	100
Squash, Bush Scalloped -----	15	500
Thyme -----	24	170,000
Tomato -----	11	8,500 to 11,500
Turnip -----	24	13,000
Watermelon -----	16	125 to 150

CHAPTER XXVI

SUGGESTIONS ON LABORATORY WORK

704. Importance.—A course in vegetable gardening cannot be fully satisfactory without suitable laboratory work accompanying the lectures or recitations. Laboratory work is essential for three reasons: (1) It is the most effective means of teaching; (2) it creates enthusiasm; (3) it inspires confidence. When the laboratory work is properly managed the student not only learns methods, but he grasps principles and soon possesses a much clearer knowledge of the subject than is possible without such exercises.

705. Methods.—Laboratory work in vegetable gardening may be classified as follows: (1) Special exercises in seed testing, sowing, transplanting, spraying, constructing hotbeds and cold frames, preparing vegetables for market, etc. (See 706.) (2) Work for which the student is held daily responsible. A course in vegetable gardening should be conducted the second half of the college year, since it will then be possible for the student to acquire experience in the starting of early plants and in the making of a home or a commercial vegetable garden. This idea should be carried out whenever facilities will permit. At the beginning of the course each student should be informed as to the dimensions of the plat which he will be expected to plant and cultivate. Give him to understand that it is his problem; that he is expected to plan his work and then work his plan. A map showing the arrangement of the planting should be submitted by the student and approved by the instructor. It is necessary, of course, that the student be provided with seeds, plants, transplanting tools and other equipment, but he

must be held absolutely responsible for all details of the work which requires almost daily attention from seed sowing until the close of the college term. The students usually become very much interested in garden making, and under favorable conditions succeed remarkably well, considering that only a small portion of their time can be devoted to this work. (See Figures 108, 109 and 110.) Numerous plans of intercropping may be employed in



FIG. 108. STUDENT GARDENS AT THE PENNSYLVANIA STATE COLLEGE

student gardens. (3) Frequent problems should be given in connection with courses in vegetable gardening. The students should be required to prepare definite plans and directions for the planting of home gardens, market gardens and truck farms. There is no limit to the number of practical problems that may be assigned relating to every phase of garden work. For example, what are the seed, hotbed and cold frame requirements to grow enough plants for 10 acres of early cabbage intercropped with lettuce? And again, how much and what kinds of

fertilizers will be needed for a typical truck farm of 100 acres to supply the nearest city market? Problems in companion and succession cropping and rotation are exceedingly valuable. Work of this character may constitute a part of the laboratory practice, although most of it should be done between class periods.

706. Definite lines of work.—As the character of the work undertaken will vary exceedingly in various localities, the following notes must be regarded as merely suggestive.

CHAPTER III, SOILS.—If there are different soil types in the community they should be inspected, if possible, to determine their adaptability for garden crops.

CHAPTER IV, TILLAGE AND TILLAGE TOOLS.—(1) Plow part of the garden plat in the fall and the remainder early in the spring. Note the difference in the moisture supply and in other physical properties. (2) Study the various types of tools on the premises or at local supply houses. (3) If possible, make an actual test of the important types of hand and horse implements.

CHAPTER V, STABLE MANURES.—(1) Make applications of various classes of manure for a few important vegetables. Demonstrations with fresh and rotten manure should prove especially valuable. (2) Make a compost pile of manures and other materials if available.

CHAPTER VI, GREEN MANURES AND COVER CROPS.—Study the character and extent of top and root growth of different classes of green manures and cover crops growing in the vicinity.

CHAPTER VII, COMMERCIAL FERTILIZERS.—(1) Determine the fertilizer requirement of the plat to be planted. (2) Each student should mix and apply the materials which have been determined for his particular plat. (3) Apply nitrate of soda at different stages of growth. Various methods of application may also be tested.

CHAPTER VIII, IRRIGATION.—Study the various parts used in the overhead system of irrigation.

CHAPTER IX, INSECT ENEMIES AND DISEASES.—(1) Study the various types of nozzles and pumps. (2) Prepare spraying mixtures, unless this experience has been gained in previous courses. (3) Make the necessary applications for the control of insects or diseases in the assigned plats.

CHAPTER X, SEEDS AND SEED GROWING.—(1) If the course is offered in the fall, there will be abundant op-



FIG. 109. STUDENTS AT WORK IN THE GARDENS OF THE PENNSYLVANIA STATE COLLEGE

portunity for the selection, harvesting, cleaning and curing of seeds. (2) Make germination tests of old and new seeds.

CHAPTER XI, CONSTRUCTION OF HOTBEDS.—(1) Practice in painting and glazing hotbed sash. (2) Construct frames. (3) Select and prepare the manure and fill the pit.

CHAPTER XII, CONSTRUCTION OF COLD FRAMES.—If possible the student should have actual experience in frame construction.

CHAPTER XIV, SEED SOWING.—(1) Sow seeds under glass for the early plants needed in the student gardens. Special care should be exercised in preparing soil for this work, and the seed beds should be cared for daily. (2) Sowing in the student plats. (3) Demonstrations under favorable and unfavorable conditions.

CHAPTER XV, TRANSPLANTING.—(1) Practice exercises, using different methods. (2) Transplant seedlings to be used in garden plats, and care for them daily. (3) Transplant in the student gardens at the proper time.

CHAPTER XVI, GROWING EARLY VEGETABLE PLANTS UNDER GLASS.—The full responsibility in growing the plants needed for the student gardens is essential in the training of efficient gardeners. Ventilation of frames should be managed by an employee, because students are often engaged in other college duties when this work must be done. It is also usually important for an assistant to attend to placing and removing mats. All watering in the greenhouse or frames should be done by the student.

CHAPTER XVII, MARKETING.—(1) Any part which the students can take in harvesting and preparing produce for market will be excellent training. (2) The various types of packages should be exhibited and their merits discussed.

CHAPTER XIX, THE STORAGE OF VEGETABLES.—It may be possible for the students to gain practical experience in the storing of vegetables by various methods.

CHAPTER XXI, CULTURAL DIRECTIONS.—The student garden plats afford ample opportunity for practice in the growing of vegetables. Emulation among the students should be encouraged. The plat work should be conducted in a systematic manner. There should be close adherence to the principles as taught in the class room. The college garden is a different proposition from the graded school garden. It is a miniature but real com-

mercial enterprise in which science is brought to bear at every point. Food and moisture requirements are considered; planting distances determined; habits of growth studied; insect and fungous enemies combated and products harvested and prepared for market.

The gardens should not be larger than can be properly cared for by the student in the time available for this work; 20 x 50 feet is about right for a two-hour labora-



FIG. 110. STUDENTS AT WORK IN THE GARDENS AT THE PENNSYLVANIA STATE COLLEGE

tory period weekly. Much of the work will be done at odd times by the students. This is important, because rainy weather or an excessive supply of soil moisture often prevents work at the scheduled hours.

No allusion has been made in this chapter to the systematic study of vegetables. The student gardens, however, afford a large amount of excellent material for this work, but such study should be treated in a separate course, as indicated in the introductory remarks.

INDEX

	Page		Page
Advertising.....	176	Bean, soil preparation.....	234
Appalachian Mountains.....	23	soils.....	233
Apple, companion crop.....	486	supporting.....	239
Arsenate of lead.....	87	varieties.....	230, 231, 232
Artichoke, globe, culture.....	201	weevil.....	243
uses.....	201	yields.....	243
Artichoke, Jerusalem, culture.....	202	Beet, companion crop.....	478, 479, 480
uses.....	202	climatic requirements.....	246
Asparagus, age of plantation.....	223	cultivation.....	250
beetle.....	224	fertilizing.....	250
botany.....	203	fungous diseases.....	252
climatic requirements.....	205	history.....	245
cultivation.....	218	importance.....	245
fertilizing.....	213	insect enemies.....	251
green.....	211	marketing.....	250
harvesting.....	220	planting.....	247
history.....	202, 226	seed required.....	495
insect enemies.....	224	soil.....	246
importance.....	204	varieties.....	246, 247
marketing.....	221	Bordeaux mixture.....	90
planting.....	217	Borecole.....	348
planting distances.....	216	Broccoli, character.....	252
plant selection.....	209	culture.....	252
propagation.....	208	importance.....	252
returns.....	223	seed required.....	495
rust.....	225	Brussels sprouts, character.....	253
seed selection.....	206	culture.....	253
soil preparation.....	212	importance.....	253
soils.....	206	Bulb crops, requirements.....	197, 199
varieties.....	204, 205	Burying vegetables.....	195
white.....	211	Cabbage, alpha group.....	260
yields.....	223	aphis.....	283
Aspect.....	13	botany of cultivated forms.....	255
Aster, companion crop.....	482	botany of wild.....	254
Atlantic and gulf coastal plains....	20	black rot.....	288
Auto trucks.....	181	classification.....	255
Baskets.....	171	climate.....	264
Bastrop series.....	20	club root.....	286
Bean.....	226	companion crop.....	477, 478, 480, 486, 488
bean, anthracnose.....	244	composition.....	269
classification.....	226, 227	cultivation.....	273
climatic requirements.....	233	Danish Ball Head group.....	261
companion crop....	483, 484, 485, 486, 487, 488	diseases.....	289
composition.....	228	early plants, growing.....	265
cultivation.....	240	Flat Dutch or Drumhead group	258
fertilizing.....	235	harvesting.....	273
harvesting.....	240	history.....	254
history.....	226	imported cabbage worm.....	285
importance.....	228	insect enemies.....	285
keys and descriptions.....	230	intercropping.....	273
marketing.....	242	irrigation.....	75
planting.....	237, 238	late plants, growing.....	266
returns.....	243	maggot.....	282
rotation.....	234	manure and fertilizer requirements	269
seed selection.....	236	marketing.....	274
soil improvers.....	229	planting distances.....	271

	Page		Page
Cabbage, red group	260	Celery, returns	325
returns	281	seed required	495
sauerkraut	289	seed, sources	307
Savoy group	259	soils	305
seed growing	263	soil preparation	310
seed required	495	storing	321
soil preparation	268	varieties	304, 305
soils	265	Cellars for storage	194
source of seed	262	Chard	327
sowing where the plants are to		Chemical properties of soils	27
mature	267	Chicory	327
storage houses	276	Chive	328
storing	275	Classification of vegetables	196, 197
transplanting in the field	272	Clyde series	24
varieties	257, 258, 259, 260, 261	Cold frames, arrangement	114
Volga group	261	construction	114
Wakefield and Winningstadt group	256	frame	115
yields	281	grading	115
Canada field peas	56	heating	118
Capitalization	189	location	114
Capital required	6	soil	117
Carbolic acid emulsion	89	storage	195
Care of plants	157	uses	118
Care of seedlings	155	Cole crops	199
Carrot, beetle	295	Collard	328
climate	290	Collington sandy loam	22
companion crop	478, 479, 480	Companion cropping	476
cultivating	293	Companion cropping, plans	477
fertilizing	293	Condimental herbs	199
history and importance	290	Co-operation	9, 189, 190, 191
marketing	293	Corn salad	329
planting	291	Cover crops	53
seed required	495	Cowpeas	12, 56
soil	290	Crates	171
varieties	291	Cress, garden	330
Cauliflower, climate	297	pepper	330
cultivation	300	upland	330
fertilizing	299	water	329
history	295	Crimson clover	55
importance	295	Crockett series	20
insects and diseases	301	Crop rotation, examples	474
marketing	300	necessity	472
planting	299	relation to food supply	472
protecting the heads	391	relation to humus	472
raising early plants	298	relation to insects and diseases	473
raising late plants	299	relation to other factors	473
returns	301	relation to toxics	473
seed	298	Crops for foliage	197
seed required	495	Cucumber, botany	331
soil	298	climatic requirements	331
varieties	298	companion crop	483, 488
Celery, culture	301	cultivation	335
Celery, blanching	315	diseases	338
botany	303	fertilizing	333
climatic requirements	305	history	330
companion crop	481, 482, 485	importance	330
cultivation	314	marketing	335
diseases	326	planting	334
fertilizing	311	returns	336
harvesting	319	seed required	495
history	302	seed, sources	332
importance	302	soil preparation	333
insects	326	soils	332
irrigation	315	starting early plants	332
marketing	319	striped beetle	336
mulching	314	varieties	331
planting	312	yields	336
propagation	308	Cucurbitous crops	198, 200

	Page		Page
Cultivation.....	34	Greenhouses, position.....	121
Dandelion.....	338	roof construction.....	124
Dibbling machine.....	146	semi-iron construction.....	122
Dill.....	338	size.....	120
Diseases.....	85	ventilators.....	126
Disking.....	31	walks.....	127
Distribution.....	187	walls.....	123
Double-glass sash.....	108	workroom.....	129
Dragging.....	32	Green manures.....	53
Drainage.....	26	Green manures, extent used.....	53
Dunkirk series.....	24	source of humus.....	53
Earliness.....	4	Gulf stream.....	13
Eggplant, botany.....	339	Gumbo.....	379
climatic requirements.....	340	Hairy vetch.....	56
cultivation.....	342	Hampers.....	171
enemies.....	343	Hand hoes.....	39
fertilizing.....	342	Hand sowing.....	135
history.....	339	Hardening plants.....	159
importance.....	339	Harrowing.....	30
marketing.....	342	Harvesting vegetables.....	163, 194
planting.....	342	Hellebore.....	88
seed required.....	495	Hempstead loam.....	22
seed, source.....	340	Hoeing.....	37
soil.....	340	Home vegetable garden, aims.....	489
soil preparation.....	342	importance.....	489
starting early plants.....	341	location.....	491
uses.....	339	management.....	492
varieties.....	339	plans.....	492
Endive, blanching.....	344	use of glass.....	491
importance.....	343	varieties.....	491
planting.....	344	Home vegetable gardening.....	2
seed required.....	495	Horse-radish, companion crop.....	478, 479
soil.....	344	culture.....	347
varieties.....	344	harvesting.....	347
Facilities for packing.....	166	history.....	346
Fall plowing.....	29	importance.....	346
Farm gardening.....	2	propagation.....	346
Fertilizers.....	58	soil.....	346
Fertilizers, application, methods of.....	67	storing.....	347
excessive application.....	63	uses.....	346
home mixing.....	69	yields.....	348
rate of application.....	62	Horse weeders.....	39
Flats.....	152	Hotbed, arrangement.....	104
Forcing boxes.....	118	construction.....	103
Frames, heating by flues.....	112	extent used.....	104
heating with hot water.....	113	filling pit.....	110
heating with steam.....	113	frame.....	106
Gardens, student.....	502, 503	location.....	104
Garlic.....	345	manure and preparation.....	109
Glacial lake and river terraces.....	24	pit.....	105
Glacial and loessial regions.....	23	sash.....	107
Glass, necessity.....	103	uses.....	113
Grading.....	174	various types.....	110
Green crops.....	27	Huntingdon series.....	22
Greenhouses, advantages.....	119	Ideals.....	3
beds.....	127	Insect enemies.....	85
benches.....	127	Insecticides.....	87
boiler.....	129	Irrigation.....	13
extent used.....	119	Irrigation, benefits.....	74
form of construction.....	122	extent of.....	72
glass.....	125	furrow method.....	77
glazing.....	126	hose application.....	78
heating.....	128	opportunities.....	72
location.....	121	overhead system.....	79
manure heated.....	111	Kale, culture.....	348
materials.....	121	fertilizing.....	348
painting.....	126	history.....	348
pipes and piping.....	128	importance.....	348

	Page		Page
Kale, marketing	349	Manure, transportation	46
planting	348	Manurial crops, fertilizers	57
seed required	495	Markers	141
soil	348	Market, kind	4
varieties	348	local	5
Kerosene emulsion	88	Market gardening	1
Kohl-rabi, culture	349	Marketing	162
importance	349	principles involved	162
marketing	350	Markets	11
seed required	495	Market wagons	177, 178, 179
varieties	349	Marking	141
Laboratory work, definite lines	500	Marshall series	23
importance	498	Martynia	359, 200
methods	498	Mats	154
Laborers, Italian	8	Mats, use	157
Labor problems	7	Meeker smoothing harrow	31
Labor supply	15	Men, required to the acre	7
Land	2	Methods of selling	15
Land, price	15	Miami series	24
contour	13	Mint	359
Laredo series	20	Miscellaneous insecticides	89
Leek	350	Montreal melons	376
Lettuce, classes	352, 353	Motor market boat	183
climatic requirements	354	Muck and peat	22, 24
companion crop	477, 478, 480, 482, 488	Mushroom	199
cultivation	358	Muskmelon, botany	360
enemies	358	classes	361
fertilizing	356	climatic requirements	363
history	351	companion crop	485
importance	351	crates	375
irrigation	358	cultivation	373
marketing	358	diseases	376
planting	357	fertilizing	369
returns	358	history	360
seed	355	importance	360
seed required	495	insect enemies	376
soil	355	marketing	373
starting early plants	355	Montreal	367, 376
varieties	351	netting	374
yields	358	planting	370
Level tillage	37	quality	374
Lime, use	65	seed	364
Limestone uplands	23	seed required	495
Limestone valleys	23	soil	364
Location	11	soil preparation	369
Location, climate	12	starting early plants	366
selection	11	varieties	361, 362, 363
soil selected	12	yields	376
Long Island home hamper	173	Mustard	379
Lufkin series	21	Negro laborers	8
Malnutrition	64	Night soil	50
Mammoth clover	54	Nitrate of soda	59, 60
Manure, composting	47	application	61
cost	16, 45	Nitrogen, use	59
cow	43	Norfolk series	21
extent used	41	Novelties	100
fresh versus rotten	47	Nozzles	87
hen	44	Number of plants required per acre	494
hog	43	Oats	56
horse	43	Okra	379
method of application	49	Olericulture	1
rate of application	50	Onion, botany	380
sheep	43	Bermuda	402
source of humus	42	bunching	404
source of plant food	42	climatic requirements	383
supply	16	companion crop	481, 482
time of application	49	cost of production	400, 401
		cultivation	394

	Page		Page
Onion, diseases	406	Plowing	29
fertilizing	387	Potash, use	62
foreign types	383	Potato	1
growing from sets	392	Potato, companion crop	485
growing sets	402	Potherbs	198, 199
harvesting	396	Pots	160
history	380	Prices	5
importance	380	Profits	4
insects	405	Pulse crops	199
irrigation	395	Pumpkin	416
marketing	400	Radish, climatic requirements	417
picklers, growing	404	companion crop	477, 478, 479, 480, 481, 487
returns	400	fertilizing	419
seed	385	history	417
seed and sets required	495	importance	417
soil	384	marketing	419
soil preparation	386	planting	418
sowing in field	389	seed required	495
storing	397	soil	417
transplanting	390	varieties	417, 418
varieties	381, 382	Raspberry, companion crop	485
yields	400	Red clover	54
Orangeburg series	21	Retailing	184
Organizations	188	Rhubarb, climatic requirements	419
Pacific Coast	24	cultivation	421
Packing	166	fertilizing	421
Paper pots	160	history	419
Paris green	88	importance	419
Parsley	406	marketing	422
Parsley, seed required	495	planting	420
Parsnip	407	propagation	419
Parsnip, companion crop	479, 480, 487	seed required	495
Patapsco Neck	51	soil	419
Pea, climatic requirements	410	River flood plains	22
companion crop	479, 484, 485, 486	Roads	14
composition	409	Root crops	197
enemies	413	Rutabaga	422
fertilizing	411	Rye	55
harvesting	413	Sage	423
history	408	Salad crops	198, 199
importance	408	Salsify	423
marketing	413	Salsify, companion crop	479
planting	412	seed required	495
seed required	495	Sand, advantages	25
soil	411	Sash	107
supporting	412	Sassafras series	21
varieties	409, 410	Savory	424
Peach, companion crop	486	Seed bed, shading	138
Pepper, climatic requirements	414	Seeds	92
fertilizing	416	Seeds, breeding	93
harvesting	416	buying	99
history	414	change	99
importance	414	cleaning	97
marketing	416	commercial growing	94
planting	416	curing	97
seed	415	growing	92
seed required	495	growing at home	96
soil	414	guarantees	99
starting early plants	415	harvesting	97
varieties	414, 415	importance of good seed	92
Peppers	75	longevity	102
Perennial vegetables	199, 200	number in an ounce	496
Phosphoric acid, use	62	old versus new	100
Piece work	9	per cent. germinating	101
Piedmont plateau	23	preservation	98
Pits	194	quantity required for acre	494
Plank drag	32	selection	93
Plant boxes	152		

	Page		Page
Seeds, soaking.....	134	Sweet corn, late varieties	431
sowing with machines.....	137	marketing.....	434
testing.....	100	midseason varieties.....	431
weight.....	496	planting.....	433
Seed sowing, broadcasting	134	returns.....	434
depth.....	133	seed.....	431
drilling.....	134	seed required.....	495
firming soil.....	137	soil preparation.....	432
moisture conditions.....	130	starting early plants.....	432
quantity to sow.....	132	suckering.....	434
seed selection.....	130	Sweet herbs.....	199
soil preparation.....	130	Sweet potatoes, botany.....	435
soil selection.....	130	climatic requirements.....	439
soil temperature.....	131	cultivation.....	447
when.....	131	diseases.....	449
Selling to retailer.....	185	fertilizing.....	444
Selling to wholesaler.....	186	harvesting.....	448
Shading.....	149	history.....	435
Shallot.....	424	importance.....	435
Shipping facilities.....	14	insects.....	449
Shutters.....	154	marketing.....	448
Skinner irrigation.....	114	planting.....	446
Soaps.....	89	propagation.....	441
Sods for transplanting.....	160	returns.....	449
Soil adaptation.....	27	seed.....	440
Soil class.....	17	soil preparation.....	444
Soil series.....	20	soils.....	439
Soil texture.....	25	storage.....	448
Soil type.....	17	varieties.....	436, 437, 438
Soils, classification.....	17	Swiss chard, companion crop.....	479
preparation.....	32	Tenant houses.....	8
Solanaceous crops.....	198, 199	Thinning.....	133
Soy Bean.....	57	Thyme.....	450
Spinach, companion crop.....	484, 487	Tillage.....	28
culture.....	426	Tillage, implements, value.....	29
history.....	425	level.....	37
importance.....	425	objects.....	28
seed required.....	495	tools.....	28
varieties.....	425, 426	Tobacco.....	89
Spotting boards.....	145	Tomato, classification.....	451
Spraying.....	86	climate.....	452
Spray pumps.....	86	companion crop.....	483, 484, 486
Squash, companion crop.....	483	composition.....	459
culture.....	428	cultivation.....	461
enemies.....	429	diseases.....	465
history.....	427	early varieties.....	454
importance.....	427	fertilizing.....	458
marketing.....	429	harvesting.....	463
seed required.....	495	history.....	450
storage.....	429	importance.....	451
summer varieties.....	427	insects.....	465
winter varieties.....	428	irrigation.....	75
Stable manures.....	41	late varieties.....	455
Sticker.....	91	marketing.....	463
Storage houses.....	194	planting.....	460
Storage of vegetables.....	193	returns.....	464
does storage pay.....	193	seed.....	456
Strawberry, companion crop.....	483, 484, 488	seed required.....	495
Subirrigation.....	78	soil preparation.....	458
Succession cropping.....	475	soils.....	452
Susquehanna series.....	21	starting early plants.....	456
Sweet corn, companion crop.....	483, 484, 485, 486, 487	starting late plants.....	458
cultivation.....	434	training.....	461
early varieties.....	430	varieties.....	454, 455
fertilizing.....	432	yields.....	464
importance.....	430	Tools, care.....	40
		Transplanting.....	139

	Page		Page
Transplanting, depth.....	144	Water, functions.....	73
field.....	148	large bodies.....	13
hand.....	144	supply.....	13
machine.....	149	Watering.....	148
reasons.....	139	Watering after sowing.....	138
soil preparation.....	140	Watermelon, climate.....	468
soil selection.....	140	companion crop.....	483
time.....	141	cultivation.....	469
Transportation by rail.....	182	early plants, starting.....	469
Transportation by water.....	182	enemies.....	471
Trucking.....	2	fertilizing.....	469
Tuber crops.....	197, 199	harvesting.....	469
Turnip.....	465, 466	history.....	467
Turnip, companion crop.....	479, 481	importance.....	467
seed required.....	495	marketing.....	469
Vegetable forcing.....	2	planting.....	469
Vegetable gardening.....	1	seed.....	468
Vegetable plants, under glass.....	151	seed required.....	495
Vegetables, most important.....	1	soil.....	468
Vegetables, preparing for market...	167	soil preparation.....	469
Virginia Produce Exchange.....	192	varieties.....	467
Wabash series.....	22	Webb series.....	22
Wagon, retail.....	184	Weeding.....	39
Water content.....	26	Wheel hoes.....	34
		Wheeling series.....	22
		Windbreaks.....	14

