



**Calhoun: The NPS Institutional Archive**  
**DSpace Repository**

---

Theses and Dissertations

1. Thesis and Dissertation Collection, all items

---

2013-03

**ALGAE-BASED BIOFUEL DISTRIBUTION  
SYSTEM TO SERVICE THE DEPARTMENT OF  
DEFENSE IN HAWAII**

Kerns, Kristen; Hopkins; Neaves, Kevin; Hopkins,  
Jonathan; Knowles, Patrick; Lisella, Michael; Young, Judith;  
Villucci, Joseph

Monterey, California. Naval Postgraduate School

---

<http://hdl.handle.net/10945/32893>

*Downloaded from NPS Archive: Calhoun*



Calhoun is a project of the Dudley Knox Library at NPS, furthering the precepts and goals of open government and government transparency. All information contained herein has been approved for release by the NPS Public Affairs Officer.

**Dudley Knox Library / Naval Postgraduate School**  
**411 Dyer Road / 1 University Circle**  
**Monterey, California USA 93943**

<http://www.nps.edu/library>



**NAVAL  
POSTGRADUATE  
SCHOOL**

**MONTEREY, CALIFORNIA**

**CAPSTONE PROJECT REPORT**

**ALGAE-BASED BIOFUEL DISTRIBUTION SYSTEM TO  
SERVICE THE DEPARTMENT OF DEFENSE IN HAWAII**

by

Team Biofuels  
Cohort 311-1130

March 2013

Capstone Project Advisors:

Brigitte T. Kwinn  
Mark M. Rhoades

**Approved for public release; distribution is unlimited**

THIS PAGE INTENTIONALLY LEFT BLANK

REPORT DOCUMENTATION PAGE			Form Approved OMB No. 0704-0188	
Public reporting burden for this collection of information is estimated to average 1 hour per response, including the time for reviewing instruction, searching existing data sources, gathering and maintaining the data needed, and completing and reviewing the collection of information. Send comments regarding this burden estimate or any other aspect of this collection of information, including suggestions for reducing this burden, to Washington headquarters Services, Directorate for Information Operations and Reports, 1215 Jefferson Davis Highway, Suite 1204, Arlington, VA 22202-4302, and to the Office of Management and Budget, Paperwork Reduction Project (0704-0188) Washington, DC 20503.				
1. AGENCY USE ONLY (Leave blank)		2. REPORT DATE March 2013	3. REPORT TYPE AND DATES COVERED Capstone Project Report July 2012 to March 2013	
4. TITLE AND SUBTITLE ALGAE-BASED BIOFUEL DISTRIBUTION SYSTEM TO SERVICE THE DEPARTMENT OF DEFENSE IN HAWAII			5. FUNDING NUMBERS N/A	
6. AUTHOR(S) Cohort 311-1130/Team Biofuels				
7. PERFORMING ORGANIZATION NAME(S) AND ADDRESS(ES) Naval Postgraduate School Monterey, CA 93943-5000			8. PERFORMING ORGANIZATION REPORT NUMBER	
9. SPONSORING /MONITORING AGENCY NAME(S) AND ADDRESS(ES) N/A			10. SPONSORING/MONITORING AGENCY REPORT NUMBER	
11. SUPPLEMENTARY NOTES The views expressed in this thesis are those of the author and do not reflect the official policy or position of the Department of Defense or the U.S. Government. IRB Protocol number _____N/A_____.				
12a. DISTRIBUTION / AVAILABILITY STATEMENT Approved for public release; distribution is unlimited			12b. DISTRIBUTION CODE	
13. ABSTRACT (maximum 200 words) The most effective distribution system, capable of delivering 42.9 million gallons of biofuel annually to the Department of Defense aviation assets in the state of Hawaii, consists of the combination of pipeline and trucks. A tailored system engineering process using Analytical Hierarchy Process assessed stakeholders' requirements into quantifiable metrics, and used CORE to develop a functional architecture to trace these needs. The modeling software ExtendSim was used to simulate various alternatives of a distribution system comprised of pipeline and/or trucks to deliver a required capacity of the pre-mixed biofuel blend. Environmental risks of the system were assessed, and a Master Logic Diagram was used to identify ways to manage risk. Based on this analysis the capabilities and benefits of this combination system outweigh the potential risks associated with its operation. An analysis of alternatives confirmed that in terms of performance and cost, the most efficient distribution system takes part in two stages. First is the transportation of biofuel from the refinery to the Red Hill Storage Facility via the pipeline that is currently in place. From this point, trucks load the biofuel at the pumping station to continue delivery to the customers.				
14. SUBJECT TERMS Systems Engineering, Biofuel Distribution, AHP, Functional Architecture			15. NUMBER OF PAGES 227	
			16. PRICE CODE	
17. SECURITY CLASSIFICATION OF REPORT Unclassified	18. SECURITY CLASSIFICATION OF THIS PAGE Unclassified	19. SECURITY CLASSIFICATION OF ABSTRACT Unclassified	20. LIMITATION OF ABSTRACT UU	

THIS PAGE INTENTIONALLY LEFT BLANK

**Approved for public release; distribution is unlimited**

**ALGAE-BASED BIOFUEL DISTRIBUTION SYSTEM TO SERVICE THE  
DEPARTMENT OF DEFENSE IN HAWAII**

Cohort 311-1130/Team Biofuels

LT Kristen Kerns, USN  
Kevin Neaves

Jonathan Hopkins  
Patrick Knowles  
Michael Lisella

Judith Young  
Joseph Villucci

Submitted in partial fulfillment of the  
requirements for the degree of

**MASTER OF SCIENCE IN SYSTEMS ENGINEERING**

and

LCDR David Featherby, USN  
Larry Coleman

LT John Lester, USN

Roge Adversalo  
Richard Seriani

Submitted in partial fulfillment of the  
requirements for the degree of

**MASTER OF SCIENCE IN ENGINEERING SYSTEMS**

from the

**NAVAL POSTGRADUATE SCHOOL  
March 2013**

Lead Editor: \_\_\_\_\_  
Larry B. Coleman Jr.

Reviewed By:

\_\_\_\_\_  
Brigitte T. Kwinn  
Project Advisor

\_\_\_\_\_  
Mark M. Rhoades  
Project Advisor

Accepted By:

\_\_\_\_\_  
Cliff Whitcomb  
Systems Engineering Department

THIS PAGE INTENTIONALLY LEFT BLANK

## **ABSTRACT**

The most effective distribution system, capable of delivering 42.9 million gallons of biofuel annually to the Department of Defense aviation assets in the state of Hawaii, consists of a combination of pipeline and trucks. A tailored system engineering process using Analytic Hierarchy Process assessed stakeholders' requirements into quantifiable metrics, and used CORE to develop a functional architecture to trace these needs. The modeling software ExtendSim was used to simulate various alternatives of a distribution system comprised of pipeline and/or trucks to deliver a required capacity of the pre-mixed biofuel blend. Environmental risks of the system were assessed, and a Master Logic Diagram was used to identify ways to manage risk. Based on this analysis the capabilities and benefits of this combination system outweigh the potential risks associated with its operation. An analysis of alternatives confirmed that in terms of performance and cost, the most efficient distribution system takes part in two stages. First is the transportation of biofuel from the refinery to the Red Hill Storage Facility via the pipeline that is currently in place. From this point, trucks load the biofuel at the pumping station to continue delivery to the customers.



THIS PAGE INTENTIONALLY LEFT BLANK

## TABLE OF CONTENTS

<b>I.</b>	<b>DOD BIOFUEL REQUIREMENTS.....</b>	<b>1</b>
	A. INTRODUCTION AND SCOPE .....	1
	B. ASSUMPTIONS.....	2
	C. LITERATURE REVIEW .....	3
	D. PROBLEM SUMMARY .....	7
<b>II.</b>	<b>SYSTEMS ENGINEERING PROCESS.....</b>	<b>9</b>
	A. STEP 1: DOD BIOFUEL REQUIREMENTS .....	11
	B. STEP 2: BIOFUEL SYSTEM ANALYSIS: .....	11
	C. STEP 3: PRELIMINARY DESIGN.....	11
	D. STEP 4: DETAILED ANALYSIS .....	12
	E. SYSTEMS ENGINEERING PROCESS SUMMARY .....	12
<b>III.</b>	<b>BIOFUEL SYSTEM ANALYSIS.....</b>	<b>13</b>
	A. STAKEHOLDER ANALYSIS .....	13
	1. Stakeholder Identification.....	13
	2. Stakeholder Engagement.....	16
	a. Pacific Command (PACOM).....	18
	b. Hawaii State Energy Office .....	18
	c. Aloha Petroleum, LTD.....	19
	d. Defense Logistics Agency (DLA).....	20
	e. United States Coast Guard (USCG) .....	20
	f. Honeywell, Unit Operations (UOP).....	21
	g. Chevron Refinery, Campbell Industrial Park, Kapolei, HI ..	21
	3. Follow-up Stakeholder Interviews.....	22
	a. PACOM Communications .....	22
	b. Marine Corps Base Hawaii (MCBH) Communications.....	25
	4. Stakeholder Analysis Summary .....	26
	B. OPERATIONAL CONCEPT DESIGN.....	26
	C. CONTEXT MODEL.....	32
	D. VALUE SYSTEM MODELING .....	33
	E. REQUIREMENTS ANALYSIS .....	38
	1. Environmental.....	38
	2. Sustainability .....	39
	3. Constraints / Constraining.....	39
	4. Usability and Safety .....	39
	5. Functional Capability .....	39
	6. Security .....	40
	7. Service Life .....	40
	8. Maintainability.....	40
	9. Supportability and Serviceability .....	41
	10. Interoperability .....	41
	11. Producibility / Constructability and Disposability .....	42
	12. Reliability.....	42

	13.	Affordability .....	42
	14.	Availability.....	42
F.		<b>ENVIRONMENTAL ANALYSIS - TRANSPORTATION.....</b>	<b>43</b>
	1.	Physical and Chemical Properties of Biofuels.....	44
	2.	Biofuel Interactions with Petroleum Fuels .....	44
	3.	Surface Water Fate and Transport .....	45
	4.	Vadose Zone Fate and Transport.....	45
	5.	Saturated Zone Fate and Transport .....	46
	6.	General State, Local and Federal Laws (Environmental) .....	47
	7.	Applicable Environmental Laws and Regulations Overviews.....	47
	a.	<i>NEPA</i> .....	47
	b.	<i>Clean Water Act (CWA)</i> .....	48
	c.	<i>Safe Drinking Water Act (SDWA)</i> .....	48
	d.	<i>Clean Air Act (CAA)</i> .....	49
	e.	<i>Resource Conservation and Recovery Act (RCRA)</i> .....	50
	f.	<i>Pollution Prevention Act (PPA)</i> .....	51
	g.	<i>Toxic Substance Control Act (TSCA)</i> .....	52
	8.	Environmental Summary .....	53
G.		<b>BIOFUELS SYSTEM ANALYSIS SUMMARY .....</b>	<b>53</b>
IV.		<b>PRELIMINARY DESIGN .....</b>	<b>55</b>
	A.	<b>FUNCTIONAL ANALYSIS .....</b>	<b>55</b>
	1.	General Approach.....	55
	2.	Functional Identification and Decomposition .....	56
	3.	Functional Flow Block Diagrams .....	59
	a.	<i>System Resources</i> .....	60
	b.	<i>System Interfaces</i> .....	60
	c.	<i>Allocation</i> .....	62
	B.	<b>ANALYSIS OF ALTERNATIVES .....</b>	<b>65</b>
	C.	<b>MODELING AND SIMULATION .....</b>	<b>69</b>
	1.	Background .....	69
	2.	Evaluation Measures for Alternatives .....	70
	3.	Model Description and Results .....	72
	a.	<i>Description</i> .....	72
	b.	<i>Results</i> .....	72
V.		<b>DETAILED ANALYSIS .....</b>	<b>75</b>
	A.	<b>PERFORMANCE ANALYSIS.....</b>	<b>75</b>
	1.	Truck Alternative Analysis .....	76
	2.	Combined Alternative Analysis .....	80
	3.	Performance Analysis Summary .....	85
	B.	<b>COST ANALYSIS .....</b>	<b>85</b>
	1.	Mixing Phase .....	85
	2.	Transportation Phase .....	87
	3.	Transportation of fuel using the combined alternative .....	90
	4.	Distribution Phase.....	92
	5.	Cost Summary .....	93
	C.	<b>RISK ANALYSIS.....</b>	<b>94</b>

D.	ENVIRONMENTAL ANALYSIS .....	105
E.	DETAILED ANALYSIS SUMMARY .....	107
VI.	OVERALL MEASURES OF EFFECTIVENESS .....	109
A.	OVERALL MEASURE OF EFFECTIVENESS ANALYSIS .....	109
1.	Capability.....	109
2.	Environmental.....	111
3.	Usability and Safety .....	114
B.	TOTAL OVERALL MEASURE OF EFFECTIVENESS .....	116
C.	OVERALL MEASURE OF EFFECTIVENESS SUMMARY .....	117
VII.	SUMMARY, CONCLUSIONS, AND RECOMMENDATIONS .....	119
A.	CAPSTONE PROJECT SUMMARY.....	119
B.	CAPSTONE PROJECT CONCLUSIONS.....	119
C.	CAPSTONE PROJECT RECOMMENDATIONS .....	120
	LIST OF REFERENCES.....	121
	APPENDIX A: STAKEHOLDER INTERVIEWS.....	127
A.	KAUAI ISLAND UTILITY COOPERATIVE .....	127
B.	CELLANA.....	128
C.	PACIFIC BIODIESEL.....	128
D.	STATE OF HAWAII NATURAL AND WATER RESOURCES.....	129
E.	STATE OF HAWAII ENERGY OFFICE.....	129
F.	UNIVERSITY OF HAWAII, MANOA, HAWAII NATURAL ENERGY INSTITUTE.....	130
G.	UNIVERSITY OF HAWAII, MANOA, MOLECULAR BIOSCIENCES AND BIOENGINEERING .....	130
H.	KUEHNLE AGROSYSTEMS.....	130
I.	HAWAIIAN ELECTRIC COMPANY .....	130
	APPENDIX B: SYSTEM DESCRIPTION.....	131
	APPENDIX C: VALUE MODELING PROCESS.....	155
A.	CAPABILITY .....	155
B.	DISTRIBUTION.....	155
C.	MIXING.....	155
D.	STORAGE.....	155
E.	TRANSPORTATION.....	156
F.	CONSTRAINING .....	156
G.	ENVIRONMENTAL COMPLIANCE .....	156
H.	INTEROPERABILITY .....	156
I.	MAINTAINABILITY.....	156
J.	PRODUCIBILITY .....	157
K.	RELIABILITY .....	157
L.	SECURITY .....	157
M.	SERVICE LIFE .....	157
N.	SUPPORTABILITY .....	157
O.	SUSTAINABILITY .....	158
P.	USABILITY AND SAFETY .....	158

<b>APPENDIX D: COST .....</b>	<b>165</b>
<b>APPENDIX E: PROJECT MANAGEMENT PLAN (PMP).....</b>	<b>167</b>
<b>INITIAL DISTRIBUTION LIST .....</b>	<b>203</b>

## LIST OF FIGURES

Figure 1.	Jet Fuel Flashpoint Comparison (After Holmgren 2008 and Hovensa 2012) .....	3
Figure 2.	Systems Engineering Scope for Biofuels Project (After Chanda et al. 2010, 11) .....	10
Figure 3.	BDS Stakeholder Hierarchy.....	16
Figure 4.	World Oil Reserves by Region (From U.S. Energy 2007) .....	27
Figure 5.	Biofuel Operational Concept .....	29
Figure 6.	BDS – Mixing, Transportation, Distribution and Storage Concept.....	30
Figure 7.	Military Aviation Assets Hawaii .....	31
Figure 8.	Biofuel Delivery System (BDS) Context Model .....	32
Figure 9.	Value Modeling Process using AHP to Develop HOQ .....	36
Figure 10.	Overall Value Systems Hierarchy with Weighted Performance Percentages .....	37
Figure 11.	Capability Hierarchies with Weighted Performance Percentages .....	38
Figure 12.	Underground Storage Tank (UST) Fuel Release Concept (From ITRC 2011, 37) .....	44
Figure 13.	Non-Aqueous Phase Liquid (NAPL) Distributions of Fuels. (From ITRC 2011, 48) .....	46
Figure 14.	MSBE Modeling Process .....	56
Figure 15.	Function Comparison.....	57
Figure 16.	Four Top-Level Functions .....	57
Figure 17.	Functional Decomposition (Part 1, 2).....	58
Figure 18.	Functional Decomposition (Part 3, 4).....	58
Figure 19.	CORE EFFBD Overall View.....	59
Figure 20.	CORE EFFBD High-Level View of Inputs, Outputs and Resources .....	60
Figure 21.	System External Relationships .....	65
Figure 22.	Combined Alternative Mixing Phase.....	70
Figure 23.	Combined Alternative Transportation and Storage Phase .....	71
Figure 24.	Combined Alternative Distribution Phase .....	71
Figure 25.	Interaction plot of Time (hours) for the Truck Alternative.....	76
Figure 26.	Interaction plot of Excess (millions of gallons) for the Truck Alternative.....	77
Figure 27.	Excess Fuel (millions of gallons) verses 100% of consumed fuel.....	78
Figure 28.	Metric Ratios of the Truck Alternative.....	79
Figure 29.	Increasing Capacity Effect on Performance (Five Truck Alternative) .....	80
Figure 30.	Interaction plot of Time (hours) for the Combined Alternative .....	81
Figure 31.	Interaction plot of Excess (millions of gallons) for the Combined Alternative.....	81
Figure 32.	Metric Ratios of the Combined Alternative.....	83
Figure 33.	Increasing Capacity Effect on Performance (Five Truck Combined Alternative) .....	84
Figure 34.	Mixing Phase Tank Layout, Capacities, and Costs.....	86
Figure 35.	Trucking Transportation Costs per Mile by Location and Trucking Tank Capacity .....	87

Figure 36.	Trucking Transportation Annual Cost Based on DLA Data.....	89
Figure 37.	Trucking Fleet Costs by Capacity.....	90
Figure 38.	Transportation Logistics between Military Aviation Assets in Hawaii.....	91
Figure 39.	Combined Alternative Annual Transportation Costs Based on DLA Data .....	92
Figure 40.	Master Logic Diagram Example (From Stamatelos, et al. 2001, 3–12) .....	95
Figure 41.	Master Logic Diagram - Truck Option Failure to Provide Adequate Biofuel.....	96
Figure 42.	Master Logic Diagram - Combined Option / Failure to Provide Adequate Biofuel.....	97
Figure 43.	Master Logic Diagram - Truck Option / Failure to Prevent Biofuel Spill.....	97
Figure 44.	Master Logic Diagram - Combined Option / Failure to Prevent Biofuel Spill.....	98
Figure 45.	Risk Likelihood Criteria Based on (From Department of Defense 2006) .....	98
Figure 46.	Risk Consequence Criteria Based on (From Department of Defense 2006) .....	99
Figure 47.	Risks - Failure to Provide Adequate Biofuel .....	100
Figure 48.	Risks - Failure to Prevent Biofuel Spill .....	102
Figure 49.	Annual Probability of a Spill – Truck Alternative.....	103
Figure 50.	Annual Probability of a Spill – Combined Alternative.....	104
Figure 51.	Annual Probability of a Spill – Alternative Comparison.....	105
Figure 52.	Suggested Alternatives vs. VOP: Capability .....	111
Figure 53.	Suggested Alternatives vs. VOP: Environmental .....	114
Figure 54.	Suggested Alternatives vs. VOP: Usability and Safety .....	115
Figure 55.	OMOE vs. Cost.....	117
Figure 56.	Provide biofuel (EFFBD).....	136
Figure 57.	Mix (EFFBD).....	138
Figure 58.	Receive Fuel Elements (EFFBD).....	139
Figure 59.	Store elements prior to mixing (EFFBD).....	141
Figure 60.	Mix elements (EFFBD).....	142
Figure 61.	Prepare biokerosene for mixing (EFFBD).....	143
Figure 62.	Store Biofuel post-mixing (EFFBD).....	146
Figure 63.	Transport (EFFBD).....	147
Figure 64.	Receive biofuel from mixing storage (EFFBD).....	148
Figure 65.	Distribute biofuel to transportation method (EFFBD).....	149
Figure 66.	Transport biofuel (EFFBD).....	150
Figure 67.	Store (EFFBD).....	151
Figure 68.	Distribute (EFFBD) .....	152
Figure 69.	Matrix 1 - Comparing High-Level Req to Tech Characteristics (KPP).....	161
Figure 70.	Matrix 2 - Comparing the Technical Characteristics to Functions .....	162
Figure 71.	Matrix 3 - Maps Functions to Form.....	163

## LIST OF TABLES

Table 1.	Biofuel Stakeholders .....	14
Table 2.	DoD Fuel Purchases in Hawaii (Million Gallons per Year for FY09) .....	24
Table 3.	Desired Biofuel Volume to Fulfill GIFT PAC 25% Objective.....	24
Table 4.	BDS Interfaces .....	61
Table 5.	Functional Allocation.....	65
Table 6.	Simulation Variables.....	69
Table 7.	Scenarios simulated for both alternatives .....	73
Table 8.	Results for Truck Alternative.....	73
Table 9.	Results for Combined Alternative .....	74
Table 10.	Average Simulation Results of Both Alternatives .....	82
Table 11.	Frequency, Cost, Volume Data (after DLA, 2011).....	88
Table 12.	Top Five Risks of Failing to Provide the End User Adequate Biofuel.....	100
Table 13.	Top Five Risks of Failing to Prevent a Biofuel Spill.....	101
Table 14.	Distance Travelled Annually for Truck Option .....	102
Table 15.	MOP Weighting of Performance Functions .....	109
Table 16.	VOP for Capability .....	110
Table 17.	Summary of Carbon Emission VOPs for Alternatives .....	113
Table 18.	Raw Values of Risk for Trucking and Combined Alternatives .....	115
Table 19.	Total MOE for all Truck and Combined Alternatives .....	116
Table 20.	Hawaii Visit Itinerary .....	127
Table 21.	1 <sup>st</sup> Example of the Top Level System Requirements Pairwise Comparison - Single Row .....	158
Table 22.	2 <sup>nd</sup> Example of the Top Level System Requirements Pairwise Comparison - Single Row .....	159
Table 23.	Results of PACOM Top Level System Requirements Pairwise Comparison.....	159
Table 24.	Example of the Sub-Level Capability Requirements Pairwise Comparison - Single Row .....	160
Table 25.	Results of PACOM Sub Level Capability Requirements Pairwise Comparison.....	160
Table 26.	KPPs and Associated Units of Measure.....	161
Table 27.	Trucking Transportation Annual Costs by Mile .....	165
Table 28.	Trucking Transportation Annual Costs by Volume.....	166
Table 29.	Combined Alternative Annual Costs by Volume .....	166



THIS PAGE INTENTIONALLY LEFT BLANK

## LIST OF ACRONYMS AND ABBREVIATIONS

AAF	Army Air Field
AHP	Analytic Hierarchy Process
AoA	Analysis of Alternatives
ASTM	American Society for Testing and Materials
BBL	Barrel
BDS	Biofuels Distribution System
CONUS	Contiguous United States
DFE	Denatured Fuel Ethanol
DLA	Defense Logistics Agency
DoD	Department of Defense
DON	Department of the Navy
EFFBD	Enhanced Functional Flow Block Diagram
GAO	Government Accountability Office
GIFTPAC	Green Initiative for Fuels Transition Pacific
HOQ	House of Quality
ITRC	Interstate Technology & Regulatory Council
JBPHH	Joint Base Pearl Harbor-Hickam
JP	Jet Propellant
LNAPL	Light, Non-Aqueous-Phase Liquid
MBSE	Model-Based Systems Engineering
MGY	Million Gallons Per Year
MCBH	Marine Corps Base Hawaii
MOE	Measure of Effectiveness
MOP	Measure of Performance
MSC	Military Sealift Command
MTBF	Mean Time Between Failure
NASA	National Aeronautics and Space Administration
NAVAIR	Naval Air Systems Command
NAVSEA	Naval Sea Systems Command
NPS	Naval Postgraduate School

NREL	National Renewable Energy Laboratory
NWAS	Naval Warfare Assessment Station
OCONUS	Outside [the] Contiguous United States
OMOE	Overall Measure of Effectiveness
ONR	Office of Naval Research
OPEC	Organization of the Petroleum Exporting Countries
PACOM	Pacific Command
PEIS	Programmatic Environmental Impact Statement
QFD	Quality Function Deployment
R&D	Research and Development
RFQ	Request for Quotation
RFP	Request for Proposal
SASC	Senate Armed Services Committee
SE	Systems Engineering
SECNAV	Secretary of the Navy
UOP	Unit Operations
U.S. PACOM	United States Pacific Command
USC	United States Code
USCG	United States Coast Guard
USN	United States Navy
VOP	Value of Performance

## **EXECUTIVE SUMMARY**

In support of the Department of Defense (DoD) initiative to minimize the danger of dependence on foreign oil, two Naval Postgraduate School (NPS) teams delved into solving the problem on how to provide biofuel to DoD assets. One cohort tackled the cultivation and production of algae-based biofuel and the second cohort investigated the transportation and delivery system called the Biofuel Distribution System (BDS). The main focus of the BDS is to provide the most effective and affordable method to deliver biofuel from the refinery to the customers. The approach was to start small by investigating only how to transport and deliver to DoD aviation assets stationed in Hawaii, particularly the island of Oahu. As with any new technology, next generation biofuels are expensive (Dumaine 2012). This project provides a view of the existing fuel delivery system and what additional functions and capabilities are necessary to provide a more efficient fuel delivery system to support the operational need. Based on performance, risk and environmental analysis, the most effective distribution system, capable of delivering 42.9 million gallons of biofuel annually to the Department of Defense aviation assets in the state of Hawaii, consists of the combination of pipeline and trucks.

The goal of this project was to explore the concept of an effective and affordable BDS and identify the operational design, constraints, and risks applicable to the system. The team determined that a combination of existing pipelines and trucking methods provide the ideal system configuration to satisfy the requirements of the BDS. The Biofuels Team used a basic Systems Engineering process model loosely based on the evolutionary model to formulate the BDS alternatives and determine a recommended alternative. The team conducted extensive research on the problem of delivering biofuel to the military bases on Oahu and conducted a needs, stakeholder, and requirements analysis. Using stakeholders' stated requirements the team targeted the transportation method of fuel delivery systems as the primary area for trade-off analysis. After generating many potential solutions and screening based on system constraints for feasibility, two alternatives were selected as candidate system alternative. The Truck Alternative transports pre-mixed biofuel directly from the refineries to the customer via

fuel transport trucks. The Combined Alternative transports pre-mixed biofuel from the refineries to Red Hill Fuel Storage Facility. Fuel is moved from Red Hill to Wheeler Army Airfield and Marine Corps Base Hawaii (MCBH) via fuel transport and Joint Base Pearl Harbor-Hickam (JBPHH) via existing pipelines.

Biofuels Team used CORE modeling software to develop the functional architecture of the BDS. The team's general approach was to capture system requirements, translate those requirements to functions, allocate those functions to physical components, and define system functional and physical interfaces between internal system components and functions and external entities. The team then built a simulation model using ExtendSim to simulate the truck and combined pipeline/truck delivery methods. These two alternatives were simulated and detailed analysis was conducted on the results in terms of performance, cost, risk, and environmental impact.

The performance analysis showed that while both alternatives met the objectives of the system, the Combined Alternative vastly outperformed the Truck alternative in all metrics. The cost analysis performed determined fixed upfront costs for both the mixing phase and distribution phases. The transportation phase cost analysis involved recurring cost options for detailed evaluation. Two alternatives were investigated for the transportation phase including trucking transportation versus combined pipeline and trucking transportation. The analysis was itemized to include location dependent cost figures on an annual basis and the effects of using three different tanker truck sizes. The cost analysis determined that for the transportation phase the combined alternative was the most cost effective option. Total annual transportation costs, not including initial capital costs or factoring in life cycle costs, for the combined alternative were \$3.246M, or 37% less than the trucking only option costing \$5.148M. Initial capital investments total \$4.95M, which is comprised of: five mixing tanks totaling \$2.87M, five trucks and five 8,000 gallon capacity tank trailers totaling \$875K, and one holding tank at each of the three bases totaling \$1.2M.

In order to complete the risk analysis, the team adopted the National Aeronautics and Space Administration's (NASA) Probabilistic Risk Assessment Procedures Guide that recommend using Master Logic Diagram (MLD) to help identify initiating events

(IEs) during the risk management and analysis portion of the project. Using these IEs, the team analyzed the impacts of the risks for each alternative. The risk analysis showed that the primary risk to the system is a fuel spill. The results show that there is less risk of fuel spillage by utilizing existing pipelines than there is with using trucks to transport the full amount of fuel.

The environmental analysis showed that the reduction of both the number of fuel transport trucks and the distance traveled ultimately reduced the level of carbon emissions and pollution in terms of the environmental impact of both the Combined and Truck Alternative. Based on these results and the reduced number of trucks required to deliver the same amount of fuel, the Combined Alternative was determined to be the best recommendation from an environmental perspective.

The results of the performance, risk, and environmental analysis were compared to overall cost through the use of an Overall Measure of Effectiveness (OMOE) process. This led to the recommendation that the Combined Alternative utilizing five 8,000-gallon trucks and an existing pipeline network is the preferred alternative.

THIS PAGE INTENTIONALLY LEFT BLANK

## ACKNOWLEDGMENTS

The authors would like to extend their gratitude and acknowledge the help received from the following individuals that contributed to the success of this project

First of all, thanks to all of the students' families, spouses, significant others, children and parents. By providing support, patience and encouragement, they inspired us to work diligently and persevere through each and every quarter of this program.

Thanks to our advisors, Professor Mark Rhoades and Professor Brigitte Kwinn, for their guidance, good humor, and fidelity to making sure that the Capstone team provided a quality product. They ensured that our efforts reflected the Naval Postgraduate School (NPS) mission: "High quality, relevant and unique advanced education and research programs that increase the combat effectiveness of the Naval Services, other Armed Forces of the U.S. and our partners, to enhance our national security."

Also, thanks to the Office of Engineering and Technology, Naval Sea Systems Command Naval Surface Warfare Center Port Hueneme Division, Naval Air Systems Command, Naval Sea Systems Command Naval Undersea Warfare Center, Division Newport, and Naval Sea Systems Command Naval Surface Warfare Center Carderock West Bethesda for their commitment to provide educational opportunities in the arena of Systems Engineering.

Last but not least, thanks to our stakeholders who responded to our survey and provided advice during various forms of communication.



THIS PAGE INTENTIONALLY LEFT BLANK

# **I. DOD BIOFUEL REQUIREMENTS**

## **A. INTRODUCTION AND SCOPE**

The U.S. Department of Defense (DoD) consumes over 130 million gallons of fuels for aviation per year in Hawaii, all of which needs to be imported either as crude oil or refined fuel from off-island. The U.S. DoD desires to offset the costs of importing fuel in order to reduce its dependence on foreign sources of petroleum: the new strategy is to replace up to 25% of the aviation fuel consumed in Hawaii with biofuel derived from Hawaiian algae stocks (Simonpietri 2011). This goal requires that the algae stocks in Hawaii be harvested and refined into fuel for aviation, and then be transported from the refinery to a storage facility. After storage, the biofuel is mixed with conventional aircraft fuels and then distributed to a point of use in the state of Hawaii.

The research scope of the project examined the distribution of biofuels from the refinery to the point of use by the DoD in Hawaii because there is already significant ongoing research into developing recommendations for the efficient means of growing, harvesting, and refining algae into useable biofuels. Specifically, this capstone project focused on the post-production phase in the system life cycle where biofuels are used to supplement the fuels used for aviation by the DoD in Hawaii. The team worked to recommend a strategy for the distribution of algae-based biofuel to DoD aircraft stationed within Hawaii. The capstone project team, referred to as Team Biofuels, addressed the transportation, distribution, mixing, and storage needs for this new fuel by engaging with the stakeholders, conducting a requirements analysis, a functional architecture, and then made a recommendation on the strategy for the optimal solution for the Biofuel Distribution System (BDS), the system that implements the mixing, transportation, distribution, and storage of the developed biofuel to the consumer. The problem statement is that the DoD requires a safe and efficient system to mix, transport, distribute, and store algae-based biofuel for its aircraft assets stationed in the state of Hawaii in order to meet operational schedules and reduced costs.

## **B. ASSUMPTIONS**

The following is a list of assumptions that were made by the team; these assumptions were made to both ensure that the research project could be completed within the nine month timeframe and serve as the conditions the team used as a foundation for analysis.

- The focus of the research conducted by Team Biofuels is limited to biofuel distribution to U. S. military consumers.
- The consumers of the biofuel transported are part of the DoD, located in Hawaii. Thus, the project will exclude commercial regulations governing use and distribution when such regulations are not applicable to military entities.
- The scope of the project will exclude the deliberation of methods for producing and refining biokerosene. Team Biofuel's research will focus on the process after having received biokerosene from the refinery, and then the mixture of algae based fuel with other fuels.
- The biofuel will be mixed with additives to create JP-5 and/or JP-8 and then transported in liquid form.
- The flashpoint of a fuel identifies the lowest temperature that a fuel will vaporize to form an ignitable mixture in air. Biokerosene has a higher flashpoint than petroleum JP-4 and JP-8 and its flashpoint is similar to JP-5. Since biofuel flashpoint is similar to the current fossil fuels in use by the DoD, the biofuel will have similar regulations with regard to the handling and transportation of currently produced JP-4/5/8. (Holmgren 2008)

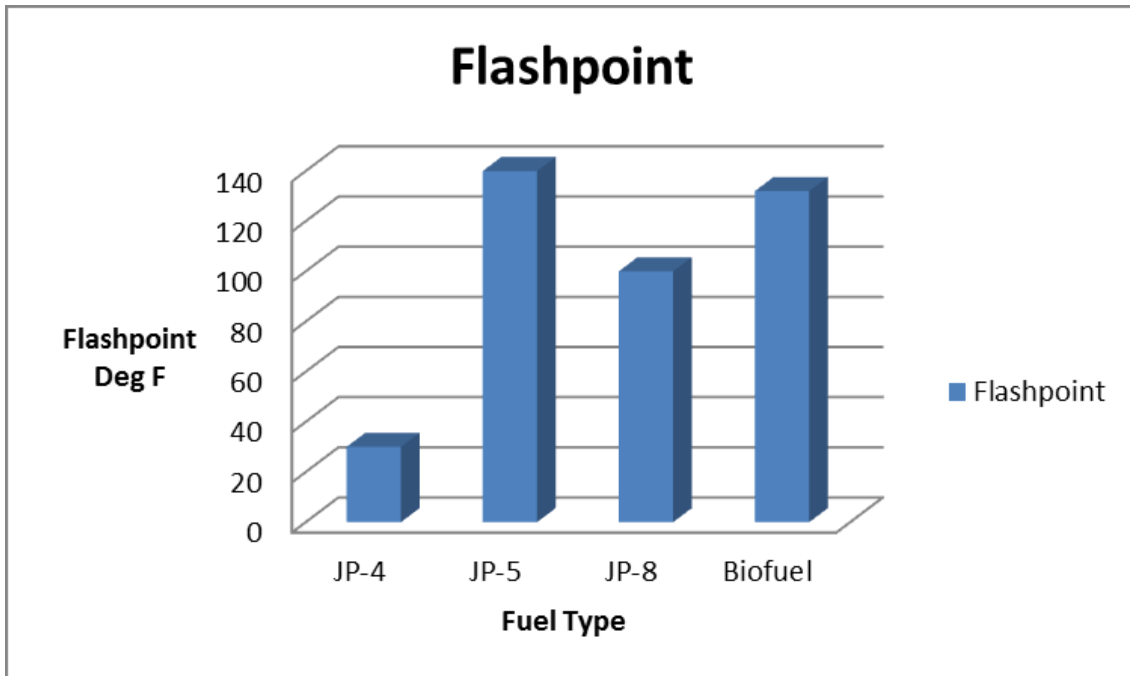

Figure 1. Jet Fuel Flashpoint Comparison (After Holmgren 2008 and Hovensa 2012)

- The usability and combustion properties of the biofuel will be consistent with current “drop-in” biofuel development efforts (U.S. DOE Alternative Fuels Data Center 2012). These “drop-in fuel” properties include the following:
  - Meets Navy fuel performance requirements.
  - Requires no change to aircraft or ship systems.
  - Can be mixed or alternated with standard aviation fuel.
- DoD stays with its existing goal of reducing its consumption of petroleum-based jet fuel in Hawaii by 25% before 2020 (Simonpietri 2011).
- The DoD will ensure infrastructure exists or provide resources to transport approximately 42.9 million gallons of biofuel per year (Simonpietri 2011).

### C. LITERATURE REVIEW

Team Biofuels completed a review of literature in order to guide the team through multiple phases of the project. Research was gathered from a variety of sources as defined by the overall scope of the project in order to support refinement of the needs statement, stakeholder requests for information, requirements development, and analysis

of alternatives. The problem statement related to distribution of algae-based biofuels as a substitute for 25% of petroleum-based fuel used for DoD aviation in Hawaii by the year 2020 required research from multiple sources to answer the following questions:

1. What petroleum-based fuels are currently used to support DoD aviation operations in Hawaii?
2. What quantity of petroleum-based fuel is required annually for DoD aviation operations in Hawaii?
3. How much algae-based biofuel would be required to meet the goal?
4. Are there existing algae-based biofuels production sources in Hawaii?
5. What are the physical and chemical characteristics of petroleum-based fuels and algae-based biofuels?
6. What are the existing requirements to qualify petroleum-based fuels and algae-based biofuels?
7. What are the requirements for storage, distribution, and usage of petroleum-based fuels and algae-based fuels?
8. What additives are used in petroleum-based fuels and algae-based biofuels?

The project need statement was validated from multiple government sources including the *2010 Naval Operational Concept: Implementing the Maritime Strategy*, which discusses the need to develop an operational concept for distribution of algae-based biofuel to supplement DON aviation usage (Roughead et al. 2010, 3). Additional research on the 2010 Naval Operational Concept also provided descriptions of U.S. Naval forces' contribution to enhancing security, preventing conflict, and prevailing in war; this validates the need statement by linking military aviation support to reducing reliance on global sources of petroleum fuels by increasing use of alternative fuels. News articles were gathered that contained public statements made by the Secretary of the Navy related to alternate fuels and reducing the Navy's reliance on fossil fuels as key to our nation's security (Cichon 2011). These news articles also produced information on biofuels research and development efforts, the costs to procure biofuels in recent years, and the Navy's execution of 2012 RIMPAC exercises using drop-in biofuels to supplement petroleum-based fuels required for Naval vessels and jets (Cichon 2011).

A briefing by the PACOM Energy Office provided a beneficial summary of PACOM strategy developed in cooperation with the Hawaii Clean Energy Initiative; this summary states the goal of replacing at least 25% of petroleum-based fuel in Hawaii with non-fossil fuels, and includes annual usage rates of aviation fuel, from which the 25% annual requirement for algae-based fuels can be derived (Simonpietri 2011). Additional details from this briefing included objectives set by the Green Initiative for Fuels Transition Pacific (GIFTPAC), such as long-term contracts for multi-year supplies of replacement fuels, top-level architecture of potential supply chains across Hawaii, models that leverage the existing local energy markets to reduce shared risks among stakeholders, discussion of scalability potential based on existing biofuels industry capabilities in Hawaii, and concepts for achieving a competitive price for replacement fuels.

Based on the PACOM briefing, the scope of the Team Biofuels project centers around the mixing, storage, transportation, and distribution of algae-based biofuels to the end user. This required research into the physical and chemical properties of both petroleum-based fuels and algae-based biofuels, as well as any constraints related to blending these fuels together and expanding current fuel storage and distribution capabilities to accommodate an additional aviation fuel for use prior to the blending point. The following fuel properties of interest were obtained: composition, color, physical state, melting and boiling points, density, odor and odor threshold, solubility in water and organic solvents, vapor pressure, auto-ignition temperature, flashpoint, flammability limits, and explosive limits. Military detail and performance specifications and standards were reviewed for legacy aviation fuel grades JP-4, JP-5, and JP-8, including requirements on the types and amounts of additives including antioxidants, metal deactivators, corrosion inhibitors and lubricity improvers, fuel system icing inhibitors, and static dissipaters. Detail specifications and qualified product lists were obtained for multiple additives for corrosion and icing inhibition and lubricity, which address requirements for properties and chemical composition (NREL 2012). These specifications also included standard testing methods to ensure that fuels and additives meet performance requirements. Additional research makes the point that the percentage

of biofuel in a fuel blend needs to provide a good balance of material compatibility, cold weather operability, performance, emission benefits, and costs (NREL 2011). These key points are critical to trade-off analysis and also helped to identify risks to be managed within this project.

The National Renewable Energy Laboratory has produced a series of guides for blending, storage, distribution, and usage of biofuels and biofuel blends for applications related to compression-ignition engines. Biofuel is a legally registered fuel and fuel additive with the EPA, which requires all biofuels to meet multiple American Society for Testing and Materials (ASTM) specifications. The biofuels manufacturing process is described in great detail, including information on the properties and advantages of biofuels, including improved fuel lubricity, reduced greenhouse gas and tailpipe emissions for particulate matter, hydrocarbon, and carbon monoxide; however, higher percentages of biofuels in fuel blends require special handling and may require equipment modifications. The properties and storage and handling requirements for various percentages of biofuels in fuel blends are provided and compared to petroleum-based fuels within the literature (NREL 2009).

Multiple sources from the Environmental Protection Agency (EPA) were reviewed to gather additional concerns and mitigation options related to storage and handling, materials compatibility, storage and thermal stability, microbial degradation, fuel contamination, and safety, health and environmental concerns were also reviewed. Several methods for blending biofuels with military aviation fuels are discussed in literature, and these methods vary based on multiple factors including the volume required for blending, finished blend level, volume of blended products being distributed, storage tank availability, equipment and operational costs, and end user requirements. Standard testing methods are also discussed for tank mixing and representative sampling, validating percent biofuels in a fuel blend, storage stability and degradation, and thermal stability. The Interstate Technology & Regulatory Council (ITRC) report titled “Technical/Regulatory Guidance Biofuels: Release Prevention, Environmental Behavior, and Remediation” discusses environmental constraints related to biofuels transportation, the physical and chemical properties of biofuels and their potential for biodegradation,

and concerns related to fuel contamination and leakage which should be addressed during design and development (ITRC 2011).

Further information on current drop-in biofuels development efforts was obtained from the U.S. DOE Alternative Fuels Data Center. This information concluded that drop-in biofuels largely meet Navy fuel performance requirements with minimal change to aircraft or ship systems and that biofuels can either be mixed or alternated with standard aviation fuel (U.S. DOE Alternative Fuels Data Center 2012).

Information related to Hawaii's existing infrastructure was also gathered from multiple studies commissioned by the Hawaii Department of Transportation (Marc M. Siah & Associates, Inc. 2009). Analysis of the existing infrastructure points to multiple distribution alternatives including use of pipelines, rail tankers, tanker trucks, or fuel tankers, while recommending an ideal situation utilizing existing petroleum-based fuel infrastructures to the maximum extent possible. These reports also detail biofuels compatibility risks with multiple materials that need to be addressed. These risks are supported by other research gathered for this project on the physical and chemical properties of biofuels. "Public Health Assessment for Pearl Harbor Naval Complex (PHNC), Pearl Harbor, Hawaii," by the Agency for Toxic Substances and Disease Registry, provided substantial information on topography and land use of PHNC, which includes Naval Station Pearl Harbor, Submarine Base Pearl Harbor, Fleet and Industrial Supply Center Pearl Harbor, Naval Shipyard and Intermediate Maintenance Facility Pearl Harbor, Naval Facilities Engineering Command HI, and Naval Magazine PH, to be used during analysis of alternatives for storage and distribution (Agency for Toxic Substances and Disease Registry 2005).

#### **D. PROBLEM SUMMARY**

To satisfy the need of the DoD to replace 25% of fuel consumed by aviation assets on Oahu, the Biofuels Team addressed the mixing, transportation, storage, and distribution of biofuel to the customer. The team developed a tailored SE process to analyze the BDS requirements, perform a system analysis, conduct preliminary design, and begin detailed analysis. The research obtained from a comprehensive literature



review in tandem with the information gathered from multiple sources and stakeholders provided the foundation of research for the project thus enabling the team to identify the pertinent stakeholders and generate requirements for the BDS.

## II. SYSTEMS ENGINEERING PROCESS

Basic Systems Engineering (SE) addresses the interconnections between items that form a system where the assemblage of those items adds value beyond their individual contributions. Working with and understanding a system is facilitated by basic systems theory, as this approach promotes the breaking of systems into more basic models for analysis. Although it can be difficult to reduce a system into a model, basic models facilitate improved analysis of a system by providing a simpler framework for analysis. Additionally, basic models may result in new directions of analysis, as basic models change the context in which one relates to the system. They can help expand conventional interactions with a system, as new models allow for different modes of interacting with and understanding a system.

In researching the SE models discussed in *Systems Engineering and Analysis*, 5<sup>th</sup> ed., by Blanchard and Fabrycky, there were a number of models that could meet the needs of the Biofuels project scope. The three most common are the “Vee” process model, Waterfall process model and the Spiral process model (Blanchard et al. 2011, 36). All the basic models focus on getting the desires of the customer developed into a viable system and they all follow a similar path to reach that goal.

The basic SE process, as described in Professor Ravi Vaidyanathan’s Fundamentals of Systems Engineering (SE3100) course at Naval Postgraduate School (NPS), takes place in the following sequence (Vaidyanathan 2011):

1. customer/stakeholder needs
2. problem decomposition
3. system design
4. component production
5. component integration, verification, and validation
6. system integration, verification, and validation
7. product delivery

While the basic SE process forms the foundation for other types of processes, and the biofuels system development includes the distribution of a completely new product and may include a significant amount of existing infrastructure, a process model suited to this new design/concept was needed.

Team Biofuel tailored a systems engineering model to focus on the early stages of the SE process because that best matched the scope of the project. The basic SE steps, 1–7, that apply to the scope of our project were adapted into the four steps in our Biofuel tailored model shown in Figure 2. The activities, as shown in Figure 2, for each of these four steps are described in the following paragraphs.

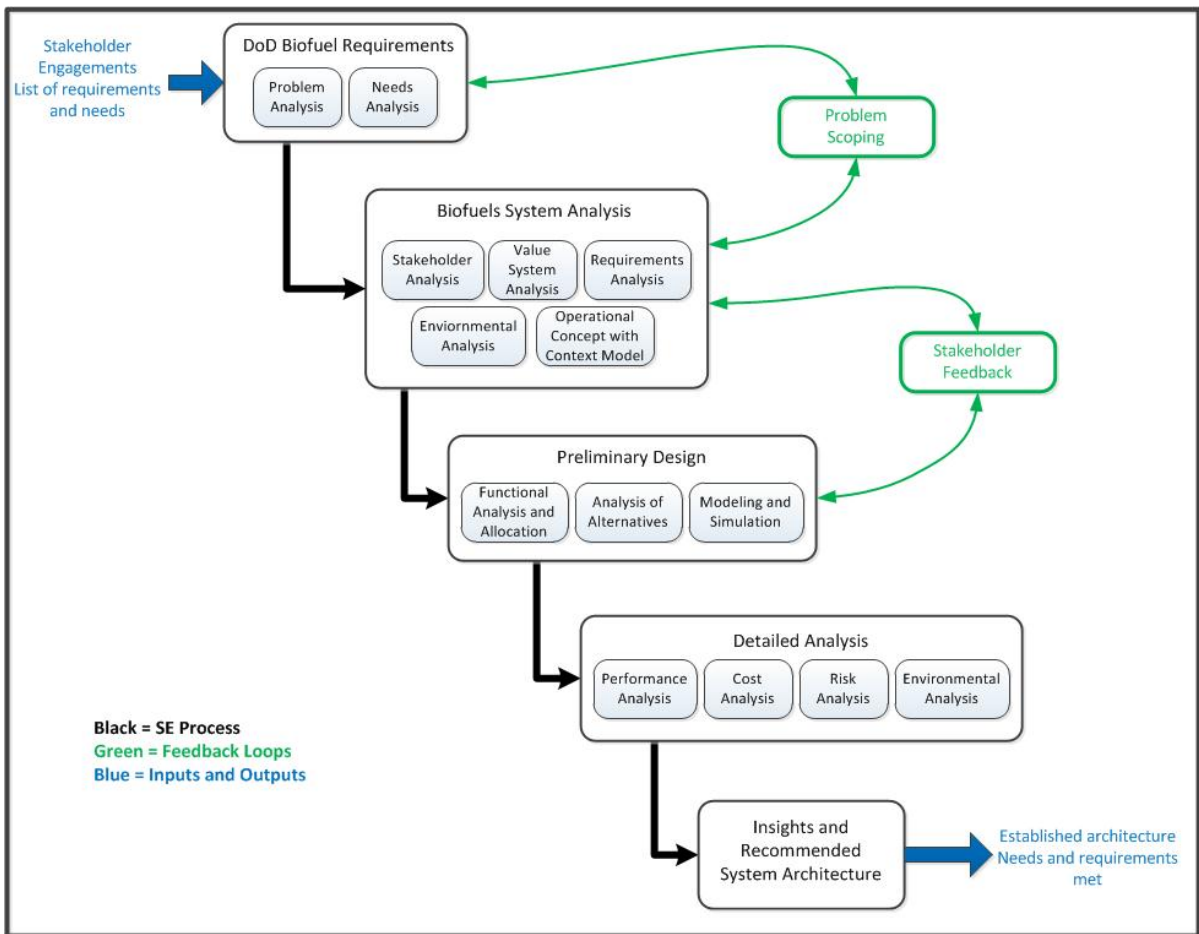

Figure 2. Systems Engineering Scope for Biofuels Project (After Chanda et al. 2010, 11)

## **A. STEP 1: DOD BIOFUEL REQUIREMENTS**

In the initial step in our SE process, we analyzed the problem of an algae-based biofuel distribution system set forth by the DoD. This included extensive research on petroleum-based fuels that are currently used by the DoD in Hawaii, the differences between existing fuels and algae-based biofuel, the unique requirements of algae-based biofuels production, as well as potential stakeholders. Once the problem was understood, a needs analysis was conducted to develop a clear statement of goals and produced an effective needs statement. The work performed during this step set the stage for the entire project and allowed the team to begin the systems analysis that followed.

## **B. STEP 2: BIOFUEL SYSTEM ANALYSIS:**

The voice, or desires, of the customer were gathered by means of engagements with stakeholders. These desires were used to generate list of system needs, and from this list, a set of criteria was generated and these formed the basis of our system requirements. Once stakeholder needs were established, they were sorted and ranked via a pairwise comparison matrix and an Analytic Hierarchy Process (AHP). This process yielded a set of weighted attributes for the system to possess that translated a subjective assessment to a quantifiable metric. These attributes were then assessed in terms of Measures of Effectiveness (MOEs) and Measures of Performance (MOPs) in the detailed analysis step of our SE process.

The operational concept was then developed including a context model. The context model allowed the team to define the boundaries of the system and to identify all of the external nodes that interact with the system.

## **C. STEP 3: PRELIMINARY DESIGN**

Alternatives were generated during the Preliminary Design phase of the Biofuel tailored model through the use or combination of several established systems engineering methods. These methods included but were not limited to brainstorming, research, and quantitative value modeling decision matrixes. Alternatives included a large array of system configurations for mixing, storage and distributing the biofuel. The list of

alternatives was screened for feasibility against MOEs and MOPs and a smaller set of alternatives was produced.

Once a list of alternatives was generated, each alternative was thoroughly analyzed by means of modeling and simulation. The simulation of these alternatives enabled performance estimation based on predetermined as well as stochastic parameters. The modeling and simulation results allowed the alternative architectures to be further narrowed based on performance and effectiveness criteria.

#### **D. STEP 4: DETAILED ANALYSIS**

The goal of the Detailed Analysis phase in the SE model was a decision, resulting in a recommended architecture for the transportation, distribution, mixing, and storage of algae-based biofuels. The cost, risk, and potential environmental impact for each of the architectures identified during modeling and simulation as being capable of meeting the system requirements was analyzed. The results of the performance, risk, and environmental analysis were compared to overall cost through the use of an Overall Measure of Effectiveness (OMOE) process to arrive at a preferred system alternative.

#### **E. SYSTEMS ENGINEERING PROCESS SUMMARY**

Team Biofuels used a tailored SE process that best fit the project scope and requirements. This resulted in a four-step process including Biofuel Requirements, System Analysis, Preliminary Design, and Detailed Design phases. The final product of the process is a recommended system alternative that meets the requirements of the stakeholders.

### **III. BIOFUEL SYSTEM ANALYSIS**

#### **A. STAKEHOLDER ANALYSIS**

Stakeholder analysis involves steps taken to identify each of the stakeholders, the stakeholders' levels of interest or involvement in the system and how that involvement can influence the project. Based on this analysis, project managers may alter how a project is executed or decide the necessary steps that must be taken in order to meet the needs of the stakeholders in the project. This information is used to assess how the interests of those stakeholders should be addressed in the project plan (Stakeholder Analysis 2013).

##### **1. Stakeholder Identification**

The Biofuel Capstone team identified five key groups of stakeholders that have an interest in the successful implementation of a Biofuels Distribution System in Hawaii. The key groups are Sponsors, Decision Makers, Users, Partners, and DoD Contractors. Sponsors will provide technical and monetary support for the project. Decision Makers include key personnel in the approval chain who are responsible for implementing the new biofuel strategy to supplement the DODs fossil fuel use in Hawaii. Users are organizations that will utilize this strategy in their missions and include end-users of the biofuel products. Partners are groups who may benefit from similar implementation of a new biofuel industry in Hawaii. DoD contractors are those companies providing systems to the DoD that could utilize biofuels. Specific stakeholders within each group were then identified based on their roles and are categorized in Table 1.

<b>Sponsors</b>	<b>Decision Makers</b>	<b>Users</b>	<b>Partners</b>	<b>DoD Contractors</b>
USN (R&D) Research and Development	(PACOM) U.S. Pacific Command	(DoD) Department of Defense	Department of the Air Force	Lockheed Martin
Academia (Researchers, Scholars)	(DoD) Department of Defense	(PACOM) U.S. Pacific Command	Department of the Army	Boeing
(ONR) Office of Naval Research	Military Bases and Storage Facilities in Hawaii	(NAVAIR) Naval Air Systems Command	Department of the Marine Corps	Northrop Grumman
	(DLA) Defense Logistics Agency	(NWSA) Naval Warfare Assessment	Department of Homeland Security	General Dynamics
	Refineries in Hawaii	Refiners	Department of Transportation	Austal
	EPA (Environmental Protection Agency)	Distributors	Department of Energy	
		Aviation Squadrons based in HI	Military Sealift Command	
			(NAVSEA) Naval Sea Systems Command	
			Commercial Aviation	

Table 1. Biofuel Stakeholders

Key stakeholders in the distribution of locally grown algae-derived biofuel include the United States Pacific Command (PACOM), the DoD, United States Department of Agriculture, Hawaiian State Government, Environmental Protection Agency (EPA), United States Coast Guard, local refineries, and fuel transportation companies are shown in Figure 3. These and other stakeholders were engaged to assist the project team with identifying a subset of stakeholders for follow-on interviews. The

Stakeholder Analysis section in Chapter II presents the details of our stakeholder interviews with the six primary stakeholders listed below, along with justification for their inclusion with the Biofuels Distribution System project. Below is the list of key decision makers involved in the biofuel project.

**Department of Defense (DoD):** First and foremost is the DoD, the top-level decision maker, who has overarching control over the nation's military assets. The DoD must maintain the balance between optimizing defense and minimizing transportation costs.

**United States Pacific Command (PACOM):** The second tier decision maker is the United States Pacific Command (PACOM), as this organization is the primary sponsor of this research effort. PACOM is responsible for the oversight of all military operations within the Pacific region. Aircraft fuel use is a major constraint for all branches of the military, especially in this region, where air support is a crucial factor in the defense of the nation. Therefore, PACOM is the primary decision maker.

**Defense Logistics Agency (DLA):** The Defense Logistics Agency (DLA) is a third tier decision maker. The DLA is responsible for providing support and services to military forces, such as the Navy. The DLA issues requests for proposals (RFPs) and request for quotations (RFQs), and then manages contracts for fuel/biofuel purchases and deliveries.

**Military Bases and Storage Facilities in Hawaii:** The fourth tier of decision makers consists of the military bases (customers) located on Hawaii that will receive shipments of biofuels needed to fuel their assets. These bases include Wheeler Army Airfield (AAF), Marine Corps Base Hawaii (MCBH), Joint Base Pearl Harbor/Hickam, and Red Hill Storage, which make up constituents of the Army, Air Force, Navy, and Marine Corps in Hawaii.

**Refineries in Hawaii:** The Chevron and Tesoro refineries are fifth-tier decision makers. The refineries obviously play an important role in the production and storage of biokerosene (the official name of biofuel produced at refineries), and therefore the



limitations of the refineries will affect the overall distribution strategy for providing biofuel to the aircraft.

**Environmental Protection Agency:** Lastly, the Environmental Protection Agency (EPA) is a sixth tier decision maker, whose regulations define the constraints under which the Biofuel Distribution System must operate.

Tier 1	Department of Defense (DoD)			
Tier 2	Pacific Command (PACOM)			
Tier 3	Defense Logistic Agency (DLA)			
Tier 4	Wheeler Army Airfield	MCB Hawaii	Red Hill Storage	Joint Base Pearl Harbor/Hickam
Tier 5	Chevron Refinery		Tesoro Refinery	
Tier 6	Environmental Protection Agency			

Figure 3. BDS Stakeholder Hierarchy

## 2. Stakeholder Engagement

A group of professors and students from the Monterey, CA based Naval Postgraduate School (NPS) visited several sites in Hawaii, including the Kuehnle AgroSystems algae strain labs, Tesoro and Chevron refineries at Campbell Industrial park, Honeywell UOP refinery mockup, algae ponds in Maui, State of Hawaii Department of Energy and Department of Natural Resources officials, DLA representatives, Hawaii Electric Company, and University of Hawaii, Manoa. Some students also attended a U.S. Department of Energy town-hall meeting held in Honolulu.

The Biofuels team’s first meetings with potential stakeholders occurred during a Naval Postgraduate School-sponsored trip to Hawaii September 2012. NPS staff and students met with the various biofuel initiative stakeholders that included

algae producers, refineries, educational institutions, and various government organizations as identified in Figure 3. The schedule and format of the meetings are shown in Appendix A.

Face-to-face discussions with some of the stakeholders were conducted. Interview questions were prepared in advances by members of Team Biofuels, with the assistance of the advising team directing the capstone research project. The stakeholders were provided questions via email prior to the encounter, giving the stakeholders a chance to review the questions before hand. The stakeholders were informed before the start of the interview that Team Biofuels was soliciting any facts and then non-proprietary information they were allowed to share. As a result of these initial questions, emails were exchanged and followed up with telephone calls.

The stakeholders had different expectations with respect to biofuels distribution. PACOM expects to see a viable, feasible, sustainable and environmentally friendly system. These desires necessitate that the research conducted into the sustainable production of algae and its ability to be refined to a usable form of aviation-grade military jet fuel be successful.

The State of Hawaii Department of Energy and Department of Natural Resources representatives voiced their full support of the project and intend to facilitate issuance of permits for building of any infrastructure that is required.

With regard to investments, PACOM needs to continue to socialize the Biofuels Distribution System with the State of Hawaii's government, with the other stakeholders, and with the people of Hawaii, to indicate that the project would produce a win-win situation. The Biofuels Distribution System can render the state a partially self-sustained biokerosene in-state production, create more jobs, and thus improve the local economy. For this whole system to become a reality not only do the key stakeholders need to pull together, the local community and those not directly affected by the biofuels initiative need to be involved. The success of the biofuel production, mixing, transportation, distribution and storage strategy is measured by the fulfillment of the stated requirement.

That is, a 25% drop-in replacement of military jet fuel at \$3/gallon by the year 2020 for the DoD military aviation assets in the state of Hawaii.

***a. Pacific Command (PACOM)***

According to the director of resources and assessments, PACOM has not set any requirement or constraints on the type of biofuel that will allow the production threshold goal of 42.9 million gallons per year to be met and has suggested that there is value in investigating a broad approach to this problem so that it can be scoped to benefit Air Force, Navy, Army, and Marine use. Therefore, the scope would then include fuel types used by these entities; thus a 50/50 bio-blend of all three primary fuels JP-8, JP-5, and F-76 (in order of importance) to service all branches found on the Hawaiian Islands. The production of the biofuel product is limited to the Hawaiian Islands requiring all growth, harvesting, refinement, and storage to be in and among the Hawaiian Islands. The use of the algae-based biofuel, however, is constrained to assets on the island of Oahu, possibly requiring transportation of the fuel in some form from refineries off-island to Oahu.

PACOM has acknowledged the importance of the DoD biofuels objective given the growing economies of foreign entities within their operating regions and the highly volatile petroleum market. These changes could greatly influence the petroleum markets in the near future and investment in alternatives is a fundamental start to a solution that will provide stability in the military aircraft fuel supply chain. The most important driver for PACOM at this time is affordability.

Although the largest consumers of petroleum fuels in Hawaii include the airline industry, power utilities, and then the DoD, the focus of this research is producing biofuels that are intended for the primary use by military assets

***b. Hawaii State Energy Office***

Permitting specialists from the Renewable Energy Projects group of the Hawaii State Energy Office discussed current trends in biofuel policy and the role that the Hawaii State Energy Office has in establishing alternative fuel policies and

programs. The Hawaii State Energy Office also serves as a resource for advice on energy and will have a role in defining the requirements for biofuel refineries and transportation systems in Hawaii.

The Hawaii State Energy Office has a group specializing in renewable energy projects that works with groups such as algae biofuel startups. The Hawaii State Energy Office's objective is to help build a clean energy economy for Hawaii. They are very in tune with the costs that Hawaii incurs from importing as much as \$4 billion of oil which is a contributing factor to Hawaii having the nation's highest energy prices. The office is set on contributing to the goal of building a clean energy economy and reaching 70% clean energy by 2030. The Biofuels Distribution System will require buy-in and approval from the Hawaii State Energy Office in order to be successful.

*c. Aloha Petroleum, LTD*

The cohorts met with the Marketing Communications Manager and the Director of Sales and Marketing at Aloha Petroleum where they viewed a slideshow detailing Aloha Petroleum's mission and capabilities. Aloha Petroleum's business is based on the retailing and storage of fuels and is Hawaii's largest independently owned gasoline, diesel, biodiesel, and ethanol distributor. The company is proactive in the commercial fuel sector for innovating and providing Hawaii's fuel needs. Aloha Petroleum as a stakeholder is a potential user as well as a partner or consultant. The company is headquartered in Oahu; however, it does retail products on the other islands by shipping its fuels to these islands via Chevron or Tesoro barges. Aloha Petroleum currently owns and operates 6 terminals, 20 trucks, and 100 gas stations in Oahu. They currently have over 500 employees.

Aloha Petroleum retails B-20 biodiesel, which is supplied by Pacific Biodiesel, to government agencies and private companies. It has held military contracts for supplying B-20 fuel for 8–10 years. They have been successful with adapting their infrastructure and equipment to handle biodiesel. Aloha Petroleum has

expansive capabilities for the storage and piping supply/distribution of fuels in Oahu. They have infrastructure to receive fuel from cargo ship and pipelines to receive from the Chevron refinery.

*d. Defense Logistics Agency (DLA)*

Team Biofuels met with Defense Logistics Agency (DLA). The representatives from DLA offered guidance as well as background information about the DLA to help our group understand their role in the fuel procurement process. The DLA handles all fuel purchases for the DoD. The DLA representatives clarified that the objective to replace 25% of the total fuel used by DoD on Hawaii means that 50% of the total fuel will remain pure petroleum product and the remaining 50% is to be a 50/50 blend of biofuels. The algae-based biofuel will be purchased as a 50/50 blend, not mixed by the government. DLA described the need for storage and distribution of both 100% petroleum and 50/50 blend without cross-contamination so dual storage and distribution systems are a requirement imposed by DLA. DLA stated that a bio-based JP-8 replacement is of the greatest priority because JP-8 accounts for 128 million gallons per year of the fuel consumed by DoD on Hawaii. DLAs primary concern with the objective to implement the 25% biofuel supplement in Hawaii is the availability of suitable land for algae production. A second concern is the inability for government to enter into long-term fuel supply contracts that would incentivize private investment in the facilities and infrastructure necessary to succeed. The scope of the BDS assumes an input of 21.45 million gallons of biokerosene to allow for 42.9 million gallons of biofuel to be produced, transported, stored, and distributed each year. The DLA's primary concerns of biokerosene production precede the BDS's scope.

*e. United States Coast Guard (USCG)*

The cohorts met with three USCG representatives who discussed the rules and regulations that they enforce regarding the transportation and transfer of fuels (hazardous materials) on waterways. The rules and regulations discussed are published within the Code of Federal Regulations (CFR) that is publically available and published by executive departments and agencies of the federal government. These rules

and regulations are important for implementation of the BDS barge option. The first regulation document discussed was title 40 (Protection of Environment) that is administered by the United States Environmental Protection Agency. Some parts of the 40 CFR that were identified by the USCG as important to our project were 40 CFR 100.3, 40 CFR 117.3, 40 CFR 129; these subparts fell under Subchapter D - Water Programs (Parts 100 - 149) which include the Clean Water Act and the Safe Drinking Water Act. Two other titles discussed included title 49 (Transportation) and title 33 (Navigation and Navigable Waters) which included the subpart 33 CFR 154 pertaining to “Facilities transferring oil or hazardous material in bulk.” The USCG requires organizations that plan to transport hazardous materials (such as fuel over water) to draft and submit a security plan. The USCG reviews and approves the security plans and will refer to these plans in the case of an emergency, such as a fuel spill. Such a plan would be required to transport the biofuel via barge from the refinery to a storage facility or point of use. It was mentioned that the security plan to transport fuels from the refineries to Marine Corps Base Hawaii at Kaneohe Bay, Oahu has not been used and for the past 6–7 years and subsequently has been placed in caretaker status; however, recently it has been requested to take this document out of caretaker status to active status, thus enabling the delivery of fuel to Kaneohe Bay via barge.

*f. Honeywell, Unit Operations (UOP)*

The Honeywell UOP division supplies and licenses refinery equipment technology and processing systems to the Tesoro refinery. UOP conducted a biomass to energy demonstration in which they converted sawdust from the mainland into oil that was refined into biofuel. Honeywell, UOP is known for developing technologies at pilot demonstration plants and selling the technology to companies that want to manage their own refineries. Honeywell, UOP helps companies become certified to refine fuel.

*g. Chevron Refinery, Campbell Industrial Park, Kapolei, HI*

Chevron provides fuel only for use in land transportation vehicles and does not produce any jet fuel for sale. The oil uptake from oil tankers into the

refinery is provided by a pipe two miles offshore. Chevron uses a single pipe system for distribution of all available fuel types. This means that the pipe has to be flushed every time another type of fuel is distributed. There are two existing 23-mile long pipes in use, both originating from Campbell Industrial Park. One pipe goes to Pier 30 by downtown Honolulu, and the other to Pearl Harbor basin by the Joint Base Pearl Harbor Hickam Makalapa gate. Chevron operates storage tanks for existing fuel products. Chevron has no plan, nor is the company capable at this time, to process and refine algae into biofuel. In addition, interviews with stakeholders revealed that there has been no business feasibility study done for algae refinement.

### **3. Follow-up Stakeholder Interviews**

After consolidating notes from the various stakeholder meetings, it was determined necessary to contact PACOM, DLA, Tesoro, and the fuel directors at Joint Base Pearl Harbor-Hickam (JBPHH), and Marine Corps Base Hawaii for follow-up questions to help define the Biofuels Distribution System requirements. Tesoro declined to answer any questions due to a pending sale. The fuels director at JBPHH declined to participate due to unspecified reasons. The results of the stakeholder interviews follow.

#### ***a. PACOM Communications***

Our team administrator contacted our primary decision-maker and sponsor, PACOM, in order to obtain additional information that would be needed for modeling and simulation efforts as well as an analysis of alternatives, risk analysis, and an environmental study. The questions were presented to our contact at PACOM, in the form of email correspondence with questions, and a response for each question was provided.

The purpose of the first question asked was to discover the total amount of aviation fuel the Biofuel Delivery System (BDS) would be expected to provide per base (Marine Corps Base Hawaii, Joint Base Pearl Harbor/Hickam, and Wheeler Army Airfield), per year. PACOM responded by stating that the consumption per base, per year, is not a metric being tracked against the Green Initiative for Fuels Transition Pacific (GIFTPAC) goal by their organization. However, the fuel requests coming from

Joint Base Pearl Harbor Hickam are watched closely, since all Navy vessels traveling to destinations beyond Hawaii refuel at this location. Additionally, PACOM also tracks the fuel requests that are received and filled by DLA, since this service is provided to all military branches. While fuel consumption is expected to change slightly from year to year, PACOM has decided to set the target value of fuel based on what was purchased in FY08/09. A replacement of 25% of this amount comes to 42.9 million gallons per year, which of course is the GIFTAC objective of this distribution system. It is important to note that PACOM was unable to provide the projected numbers for future fuel consumption due to the classified nature of this topic. However, PACOM was willing to provide the publicly releasable rate increase, which is 1.0–1.5% (DoD) consumption for each year following (Simonpietri 2011).

The purpose of the second question was to learn if a certain form of the aviation fuel, for example, JP-5 versus JP-8, used by any of the military bases, is preferable over another. PACOM responded by explaining that the GIFTAC goal was intended to supplement 25% of the fuel used by the DoD in Hawaii overall. The organization does not wish to place any limitations on the ways to achieve this goal, by specifically requesting one class of fuel over another (Simonpietri 2011).

The purpose of the third question was to verify whether or not PACOM was including marine diesel in their goal of 42.9 million gallons of replacement fuel. PACOM has confirmed that marine diesel is part of the estimate, however, the solution of 25% fuel replacement does not a specific method of fuel replacement that is achievable, whether it accounts for marine diesel, or simply takes into consideration the different classes of jet fuels (Simonpietri 2011).

Additionally, PACOM provided the following estimates used for the purposes of GIFTACs objectives:



<b>DoD Fuel Purchases in Hawaii (MGY FY09)</b>	
<b>Fuel Type</b>	<b>Quantity (MGY)</b>
JP-8 Jet	78.6
JP-5 Jet	7.2
F76 Commercial Diesel	42.3
Commercial Diesel	0.8
<b>Total</b>	<b>129</b>

Table 2. DoD Fuel Purchases in Hawaii (Million Gallons per Year for FY09)

PACOM also expressed their organization’s priorities in terms of the different types of blended biofuels. Road diesel was not included in this prioritization because the replacement fuel that will be used for such purposes has been dedicated to other fuel directives. Table 3 includes different classes of mobility fuels as well as the estimated future need to generate power for industrial plants (Simonpietri 2011).

<b>Military Installation</b>	<b>Desired Biofuel Volume (MGY)</b>
Wheeler Army Airfield	0.6
Marine Corps Base Hawaii	5.0
Joint Base Pearl Harbor-Hickam	37.3
<b>GIFTPAC objective 25% of 2009 fuel usage in Hawaii</b>	<b>42.9</b>

Table 3. Desired Biofuel Volume to Fulfill GIFTPAC 25% Objective

The estimated number of petrol-derived fuels produced and used in Hawaii is 129 million gallons per year as shown in Table 3 (Simonpietri 2011). Additionally, 42.3 million gallons of this total comes from F76 marine diesel, which will not be considered within the scope of the BDS. Therefore, the amount of petrol aviation fuel left to account for is 85.8 million gallons per year. Replacing 25% of this quantity with a biofuel will require the production of 21.45 million gallons of bio-based aviation fuel, or biokerosene, each year.

The point of contact at PACOM has provided estimates of the amount of JP-X, an aviation petrol-fuel used at the three main military installations on Hawaii. Marine Corps Base Hawaii uses approximately 5 million gallons per year, Joint Base Pearl Harbor Hickam uses approximately 37.3 million gallons per year, and

Wheeler Army Airfield uses approximately 0.6 million gallons per year (Simonpietri 2011). These amounts, in Table 4, result in a total of 42.9 million gallons of JP-X that needs to be produced, transported, stored, and distributed each year.

In order to produce a 50/50 blend of bio-based aviation fuel, this requires the mixing of 21.45 million gallons of biokerosene with an additional 21.45 million gallons of JP-X, as well as other necessary additives. The outcome will yield the 42.9 million gallons of blended aviation biofuel, meeting the requirement set by PACOM for the combined military installations in Hawaii.

***b. Marine Corps Base Hawaii (MCBH) Communications***

The Fuels Director at Marine Corps Base Hawaii was interviewed twice in late November 2012 to gain an understanding of how they receive, store, and transport fuel to the various aircraft stationed at MCBH. MCBH receives fuel from JBPHH via tanker trucks that each carry 8,000 gallons of fuel and can be off-loaded one at a time in approximately 15 to 20 minutes. In addition to receiving fuel via tanker truck, MCBH has the capability to receive fuel from barges, but has not done so in over eight years. Historically, the barges serving MCBH have between 28,000 and 32,000-barrel (bbl) capacities. MCBH has two 30,000 bbl and one 5,000 bbl storage tanks for a total storage capacity of 65,000 bbl of fuel. The fuel is tested at JBPHH before being shipped and another sample is tested at MCBHs laboratory as it is being offloaded into the local storage tanks.

MCBH refuels aircraft on hot lanes and cold lanes. The hot lanes are fixed fueling facilities where the aircraft will park to receive fuel. The cold lanes are three supply points for the thirteen 5,000-gallon capacity refueling trucks operated by MCBH. The cold lanes have two JP-8 outlets and one JP-5 outlet. They typically fuel aircraft with JP-8 but will provide JP-5 upon request. According to the fuels director for MCBH, on average, MCBH refuels approximately 11,000 aircraft with 10 million gallons of fuel per year. In addition, it is DLA who sets the requirements for how much fuel is stored on-site.

#### **4. Stakeholder Analysis Summary**

The team identified the stakeholders and their needs as an important step in the overall scope of this project. After identifying the key stakeholders and establishing regular communications, they provided sufficient information in regards to the quantity of biofuel, types of biofuel used, modes of transportation, and demand of biofuel by customer location. PACOM, DLA, and MCBH provided additional information that was used to refine the project plan and identify all of their requirements. This information was also used to define parameters for the modeling and simulation efforts, analysis of alternatives, risk analysis, and environmental studies.

#### **B. OPERATIONAL CONCEPT DESIGN**

The operation concept design focuses on a team's ability to translate the primitive need into an effective need. The Capstone project team conducted research on current event topics and used briefings from the NPS staff in order to narrow our group's interest in the study of biofuel and its incorporation into military use. The global need for fuel was the primitive need that initiated the development of the BDS concept.

Economic instability historically exists throughout many places around the globe and at times throughout our nation. Figure 4 shows the largest world oil reserve is in the potentially volatile Middle East region. The United States as a result of fluctuating oil prices in the Middle East region needed to look at more economically viable ways to maintain our military forces (OPEC 2013). The Middle Eastern region that holds over 55 percent of the world's oil reserves has a natural chokepoint (defined as a narrowing of the sea, that if sealed off by an opposing force, can limit access), called the Strait of Hormuz (OPEC 2013). This area, bordered by Iran and Oman, is a critical point in the lifeline flow of oil from the Arabian Gulf area. The U.S. military and its allies closely monitor this strait, to ensure the flow of oil, as a blockage of the strait would have serious effects to the price of fuel in the world. The strait connects the Arabian Gulf and the Gulf of Oman and is the though point in which all Middle Eastern oil must travel. Additionally, the political unrest that has pervaded throughout the region has caused the price of crude oil to "skyrocket" over the past ten years to its current rate of approximately \$100 per

barrel. Oil prices could go to over \$200 a barrel if the world's top crude exporter Saudi Arabia is hit by serious political unrest (Jones et al. 2012).

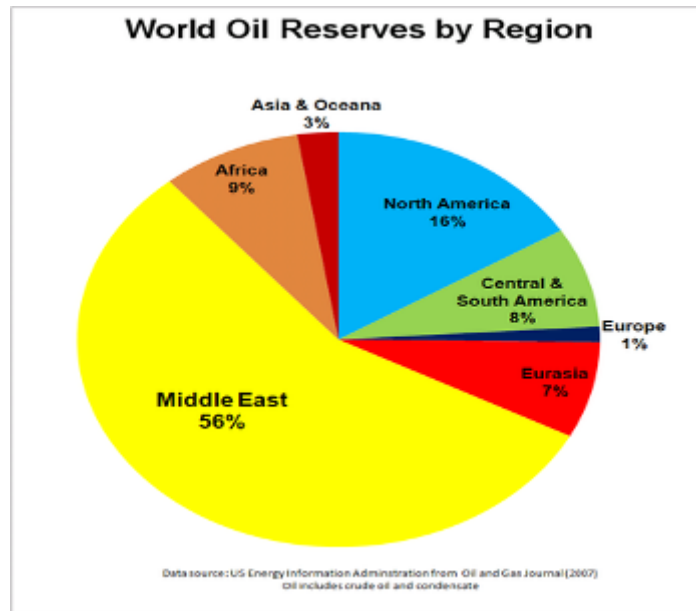

Figure 4. World Oil Reserves by Region (From U.S. Energy 2007)

Of the hundreds of military bases located throughout the United States, the bases on the island of Hawaii provide logistical challenges due to the limited natural resources and lack of existing related industrial support present on the islands. Hawaii has to import many of its necessary resources and, as a result, the extra transportation of the materials increases costs. This added cost made Hawaii military installations prime candidates for initiatives to reduce military fuel costs.

The operational concept for the distribution of algae-based biofuel to supplement DoD aviation assets in Hawaii has both fiscal and strategic implications. The fiscal side stems from the need stated by the Senate Committee on Armed Services to “emphasize the reduction of dependency on fossil fuels and seek greater energy security and independence, and pursue technological advances in traditional and alternative energy storage” (Levin, and McCain 2012, 5).

PACOM took charge in developing the DoD initiative and in October 2009, in cooperation with the state of Hawaii, released its strategy for reducing dependence on fossil fuels and assisting in the development of alternative, renewable sources of energy (U.S. Pacific 2009). It was through this initiative that the evolution of biofuel production and the system proposed by this research, the BDS concept was started. In terms of how there are strategic implications, a proposed system to diversify sources of fuel to our military assets, in particular the U. S. Navy assets, supports the Naval Operational Concept, which articulates the need to provide fuel resources to our military stationed throughout the world.

The *Naval Operations Concept 2010: Implementing the Maritime Strategy* describes “when, where and how U.S. naval forces will contribute to enhancing security, preventing conflict and prevailing in war” (Roughead et al. 2010, 3). In order to maintain the globally distributed defense in depth strategy, power projection and sea control in the Pacific, key military installations in the state of Hawaii, home to PACOM and a multitude of additional military installations need to be supported. In Figure 5, military aviation provides the air power resources to carry out the power projection in support of U.S. national interests as well as provide the ability to provide logistical supply to military forces deployed throughout the world.

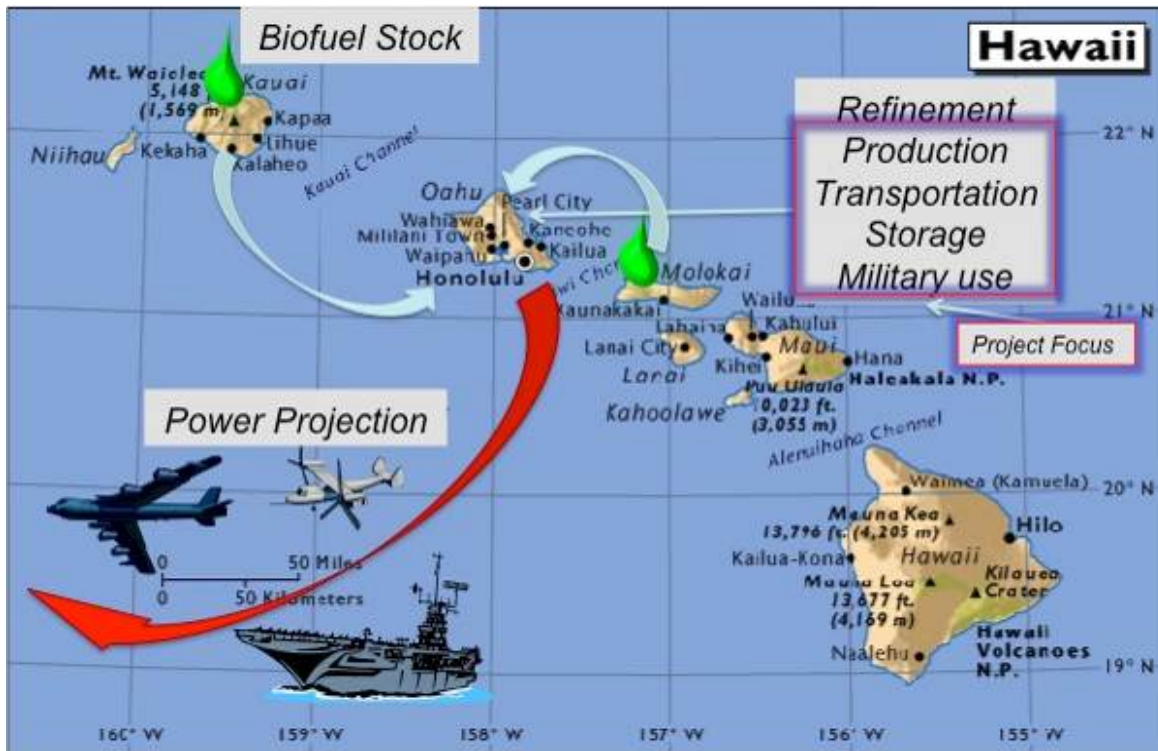

Figure 5. Biofuel Operational Concept

As has been previously stated, the economic downturn seen over the last decade and the rising costs of crude oil (exported primarily from the potentially volatile Middle Eastern region) has made the U.S. government look for alternative ways to find fuels to meet the demands of our military aviation assets. While the scope of this project focuses on the government working to develop biofuel alternatives to support DoD aviation assets in Hawaii, the DODs goal is to continue the use of biofuels beyond military aviation and into the Surface Fleet. “The Navy has pledged to use 50 percent fossil fuel alternatives by 2020, which equates to around 613 million gallons of biofuel each year” (Cichon 2011).

The concept and desire to pursue this technology has already been demonstrated by the use of 50/50 biofuel blend during a recent large-scale power projection / sea control naval exercise, Rim of the Pacific (RIMPAC) in Summer 2012. Eventually, this technology can be expanded to create biofuel resources for the civilian population within the Hawaiian Islands.

In an effort to find alternative fuels and to limit the United States' crude oil dependency from OPEC (Organization of the Petroleum Exporting Countries) nations, the DoD has set a goal to reduce its consumption of petroleum-based jet fuel in Hawaii. In an effort to meet this requirement, the DoD has chosen to pursue algae-based jet fuel over more traditional fat-based fuel (cooking oils or animal fats) as a replacement to the standard fossil-based jet fuel used by military aircraft stationed in, and flying through, Hawaii. DoD installations in Hawaii currently use 130 million gallons of jet fuel per year to sustain operations (Simonpietri 2011).



Figure 6. BDS – Mixing, Transportation, Distribution and Storage Concept

The primary operational activities that will benefit from the biofuel stocks are located on the island of Oahu. Oahu, Hawaii is home to a multitude of DoD installations. Wheeler Army Airfield, location of the 25th Infantry Brigade, is home to a multitude of helicopters from the AH-64 Apache to the UH-60 Black Hawk. Joint Base Pearl Harbor-Hickam located in Honolulu, is home to the Air Force 15th Air Wing. The airfield is primarily used for Air Force heavy transport aircraft, along with the F-22 Raptor fighter



aircraft. The base also provides fueling capability to shipboard air assets in Naval Base Pearl Harbor. In the East, the Navy and Marines are stationed at Marine Corps Base Hawaii located in the Mokapu Peninsula of Honolulu, more commonly referred to as MCBH. MCBH holds numerous Navy and Marine Corps helicopters and the Navy P-3 Orion aircraft. Figure 7 shows the Tesoro Refinery (located in the Southwestern part of the island) that provides the fuel that supplies the military installations on the island.

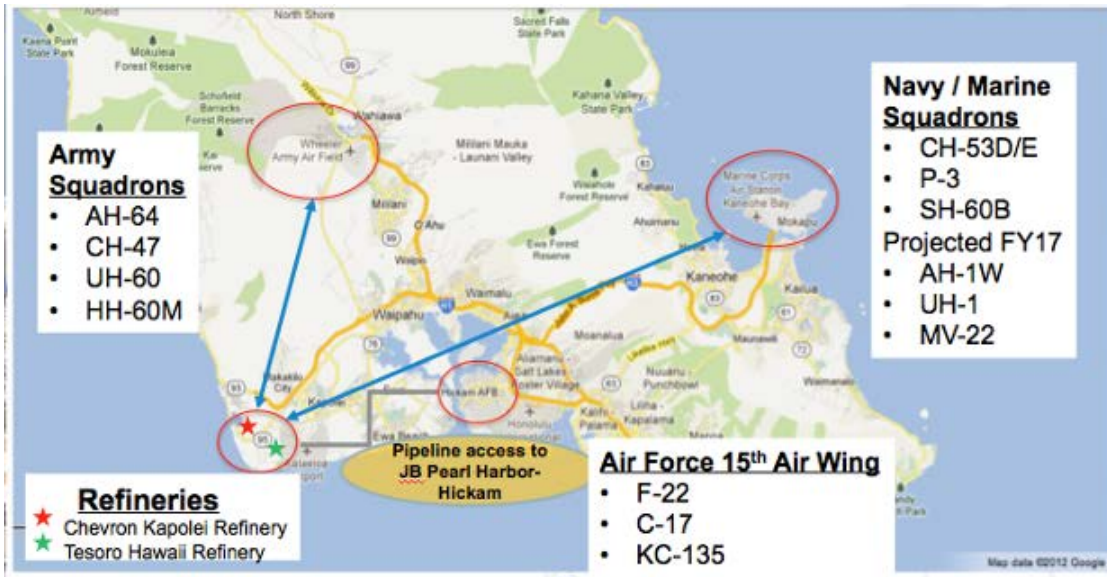

Figure 7. Military Aviation Assets Hawaii

According to the Marine Aircraft Group stationed in Hawaii, future base restructuring may include a number of additional Marine squadrons to Marine Corps Base Hawaii (MCBH), MCBH (*AH-1 Cobra / UH-1 Huey helicopters, MV-22 Osprey Tilt-Rotor aircraft and Unmanned Aerial Vehicles*) by Fiscal Year (FY) 2017 (Marine 2012). While the scope of this research centers on the requirement for DoD aviation needs, future expansion may include the inclusion of biofuel support to Naval shipping located at JBPHH.



### C. CONTEXT MODEL

A context model was developed to further examine the scope of the system, set system boundaries, identify external operational nodes, and define key relationships between the system and external systems or factors. Figure 8 is the result of the context model for the BDS. In this diagram the BDS is represented by a “black box,” meaning that it depicts no internal structure or interfaces of the system, leaving the emphasis on external relationships and inputs. Additional detailed design was accomplished in the preliminary design phase of our SE process.

In Figure 8, it can be seen that the BDS receives mixing additives and JP-X from local DLA suppliers and biokerosene from biofuel refineries and delivers finished 50/50 blended biofuel to the customer while receiving guidance, requirements, and constraints from various government entities and the operating environment. Any byproducts created from the biofuel mixing process are sent to an external disposal system for processing. This model was used as a basis for identifying and describing all external interfaces required by the system.

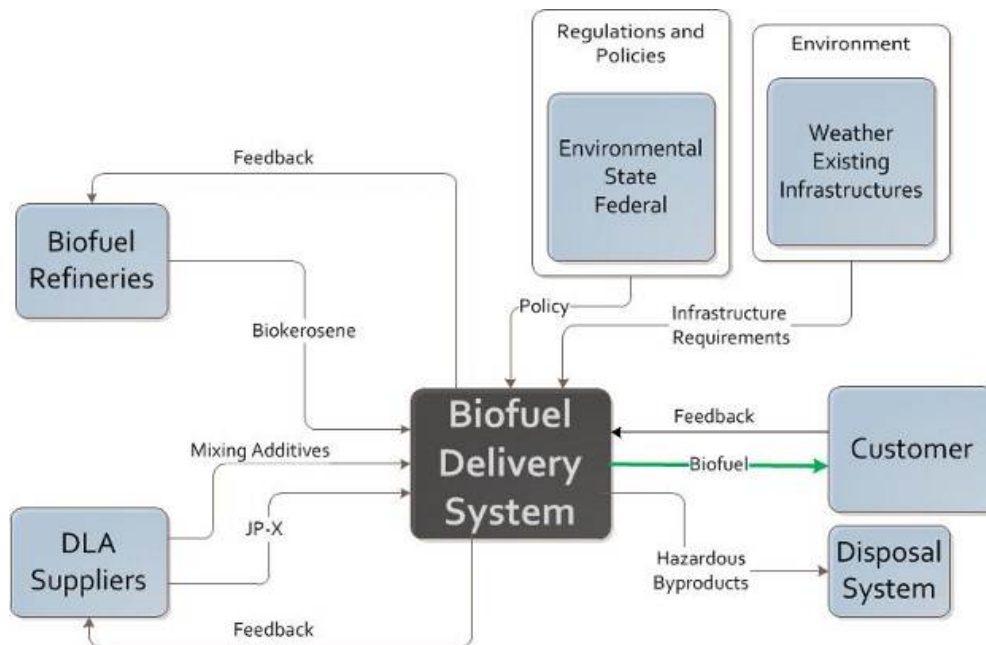

Figure 8. Biofuel Delivery System (BDS) Context Model

## **D. VALUE SYSTEM MODELING**

Value system modeling provides a methodology to evaluate solutions to problems that have multiple and, many times, conflicting objectives. A value model will provide a framework to determine how well candidate systems meet the objectives of the stakeholders. The revised problem statement is that the DON requires a safe and efficient system to transport, distribute, and store algae-based biofuel for its aircraft assets stationed in the state of Hawaii in order to meet operational schedules and achieve reduced costs. From this revised problem statement, research and stakeholder analysis, our team developed a list of the top twelve requirements necessary to solve the problem and develop a system that meets the needs and objectives of our stakeholders. These twelve requirements include:

- capability
- constraining
- environmental compliance
- interoperability
- maintainability
- producibility
- reliability
- security
- service life
- supportability
- sustainability
- usability and Safety

The top stakeholder requirements are further defined in Appendix C. From the top-level system requirements, the operational concept definition and stakeholder needs analysis, the top-level system function was determined to be Provide Capability. This function is what the system must do. It transforms the system inputs into the system

outputs. There are four sub-functions that decompose the Provide Capability function include:

1. Distribute biofuel
2. Mix biofuel
3. Store biofuel
4. Transport biofuel

The team used the Quality Function Deployment (QFD) process to organize customer requirements and needs into technical requirements. The team utilized an Analytic Hierarchy Process (AHP) in order to provide input for the “House of Quality” (HOQ) matrices during the planning phase of our research. A House of Quality is a diagram that compares the desires of the stakeholder (the “whats”) to the capabilities of the system (the “hows”), or the key performance parameters (KPPs). From the HOQ, the team was able analyze the selected values assigned by the stakeholder so that when mathematically examined, a clear and finite recommendation can be reached from among the available choices.

Several methods exist for modeling the stakeholder values. Our team chose to use the method of AHP and HOQ for many reasons. First, the AHP method can be accomplished quickly and economically. Second, it allows the user to analyze the requirements as simple comparisons. While one argument against AHP is that this can be considered a “soft” approach to determining the user’s values, and does not estimate the true value of the function(s) in question, the argument can be made that because the pairwise comparisons force the user to make a direct comparison by soliciting a definitive value for every comparison made, this approach does enable values to be assigned to the choices. (Qureshi and Harrison 2003, 454) Furthermore, the absolute value of functions such as Environmental Compliance cannot be directly measured and thus can only be estimated using comparison.

Another argument against the AHP pairwise comparisons is that there could be inconsistencies in the preferences between objectives, or rank reversal. Nonetheless, part of the AHP process involves calculating an inconsistency index which, when calculated at greater than 0.1, would have stakeholders reconsider selected judgments. This would

reduce the likelihood of inconsistencies of the results of a hierarchy developed when using the AHP. (Buede 2009, 370)

A third argument exists against the use of AHP, which questions the validity of the comparisons made due to the subjective nature of the preference weighting. However, when dealing with functions with no explicit numerical value, reliance must be made on subjective comparisons made by the stakeholders, who will ultimately assess the resulting system design. The AHP captures priorities, or the value of a function, using language comparisons that humans are familiar with and then converts these values into ratio scale numbers. “These mathematical operations are justified by a set of axioms that Saaty [1980, 1986] has developed.” (Buede 2009, 370) Additionally, the typical lack of agreement among different stakeholder groups is negated by singling out the primary stakeholder, and then analyzing a single set of comparison results. (Qureshi and Harrison 2003, 454)

From the 12 top-level requirements, the team created a pairwise comparison in the format of a table to send to our primary stakeholder, PACOM. The purpose of this pairwise comparison was to determine the stakeholder preferences for the value of the capability requirement, which includes the mixing, transportation, distribution, and storage of the final product, against every other top-level requirement that the system must also fulfill. This type of comparison ensured a standardized method of measurement of a single requirement against every other requirement. The top-level system requirement Capability was identified by our team as the variable that would be compared to the other requirements because it was derived from the operational need for the BDS.

From our stakeholder survey results we were able to build three separate HOQ matrices. Matrix 1 compares High Level Requirements to Technical Characteristics, Matrix 2 compares Technical Characteristics to Functions, and Matrix 3 compares Functions to Form. The detailed matrices can be found in Appendix C. The results of the Customer Survey indicated that the three highest ranking factors are ‘Environmental,’ ‘Sustainability,’ and ‘Constraining’ while the lowest ranking factors were ‘Producibility,’ ‘Interoperability,’ and ‘Reliability.’ This led to a Pairwise Comparison where the

weights of each factor were determined. Detailed HOQ matrices and pairwise comparison graphics and details are located in Appendix C.

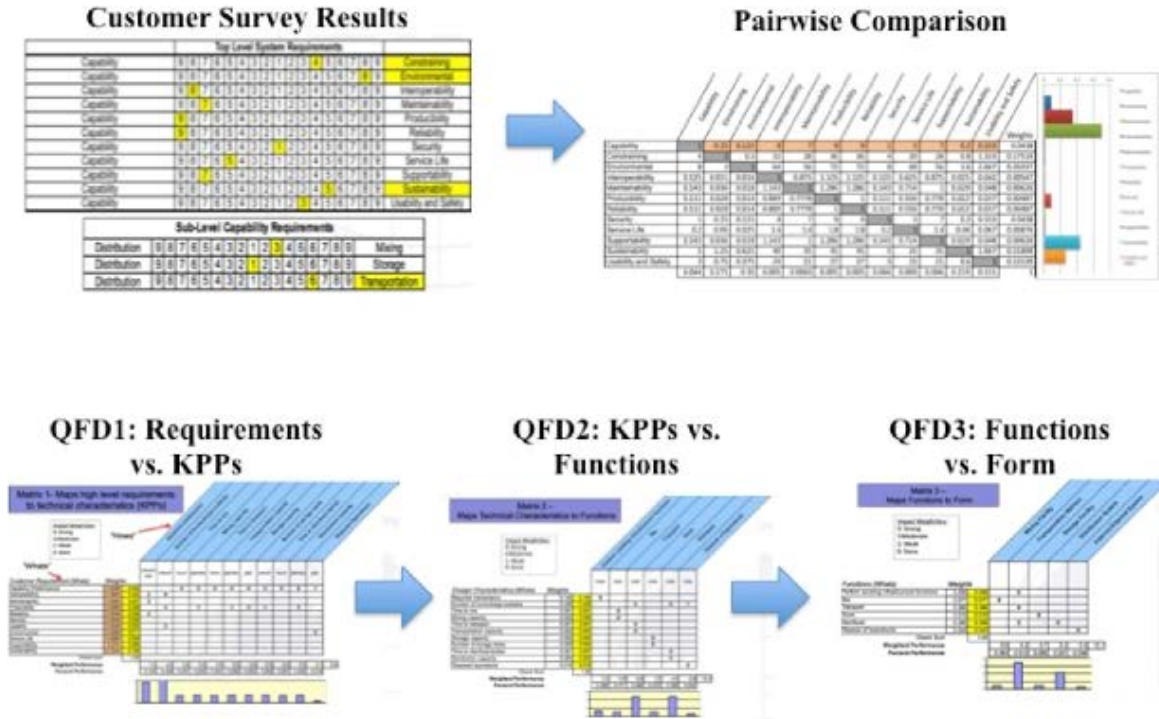

Figure 9. Value Modeling Process using AHP to Develop HOQ

The Overall Value System Hierarchy with the weighted performance percentages determined in the Pairwise Comparison is depicted in Figure 10. The Environmental category ranks highest in importance at 35.04%, and is followed by Sustainability at 21.9%, the Constraining requirement at 17.52%, and the Usability and Safety requirement at 13.14%. The Capability and Security requirements are all close in importance, yet account for less than 5% importance, individually. The remaining requirements of Service Life, Maintainability, Supportability, Interoperability, Producibility and Reliability all account for less than 1% of system performance, individually.

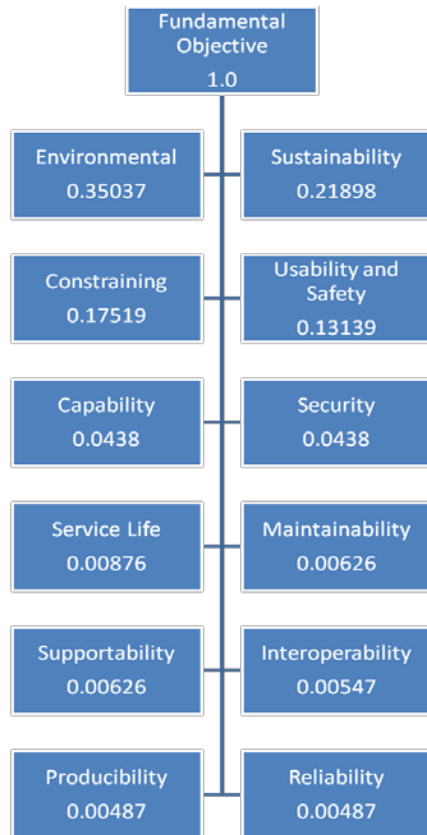

Figure 10. Overall Value Systems Hierarchy with Weighted Performance Percentages

Depicted in Figure 11 is the Capability Value System Hierarchy with the weighted performance percentages shown for each sub-level category. The same AHP process was used to determine relative importance and then assign weights to the functions. The Transportation function accounts for the highest percentage of system performance at 54.55%. Next, the Mixing function accounts for 27.27% of the importance of system performance. Finally, the Storage and Distribution functions are similar in importance, both at 9.09%.



Figure 11. Capability Hierarchies with Weighted Performance Percentages

The value model ensures that the system capabilities and performance will be mapped to the needs of the customer. The system developers can use the value model to verify that the final system recommendation will solve the problem and meet the needs of the stakeholders.

#### **E. REQUIREMENTS ANALYSIS**

The BDS is required to transport, store, and distribute up to 25% of the DODs jet fuel consumption within the state of Hawaii in a cost-effective manner. The system is required to be compatible with new and existing infrastructure. This infrastructure consists of biofuel refineries; fuel pipelines, tanker trucks, barges, and tanker ships; storage facilities; and end-use distribution equipment that includes flight line tanker and pump trucks and Military Sealift Command (MSC) supply ships.

As discussed in the Value Systems Hierarchy section, our primary Stakeholder, PACOM, ranked the System Operational Requirements in order of importance as Environmental, Sustainability, Constraining, and Usability and Safety. The following secondary requirements, Capability, Security, Service Life, Maintainability, Supportability, Interoperability, Producibility, and Reliability followed the top four System Operational Requirements. The Operational Requirements are listed below.

##### **1. Environmental**

It is the stakeholder's desire that the biofuel distribution system shall be implemented in such a way to minimize the impact to Hawaii's sensitive ecosystem.

Environmental factors are discussed in detail in the Other Requirements or Environmental Concerns Section.

## **2. Sustainability**

The biofuel distribution system shall be constructed in an environmentally conscious manner to protect the fragile Hawaiian ecosystem. Care shall be taken to minimize the impacts of constructing new facilities. Where feasible, the use of renewable energy sources will be implemented in the Biofuel Distribution System design.

## **3. Constraints / Constraining**

The Biofuels Distribution System design will be constrained by several factors including Affordability, Schedule, Environmental requirements, peacetime and surge capacity requirements, interoperability requirements, and logistical supportability requirements. These requirements are discussed separately throughout this section.

## **4. Usability and Safety**

Usability is the characteristic of design that ensures compatibility between, and safety of, system physical and functional design features and the human element in the operation, maintenance, and support of the system. (Blanchard et al. 2011, 113) Human Systems Integration (HSI) will play a key role in designing the biofuels distribution system to ensure compatibility between the system and the human operators and maintainers. The application of HSI will ensure that adequate manpower and personnel are identified to operate and maintain the various fuel distribution components.

Safety is achieved by removing conditions that can cause death, injury, and occupational illness, loss of equipment or property, and damage to the environment. (Hoivik, 2013) Through the implementation of HSI, the BDS will be designed to maximize safety of those that interact with the Biofuels Distribution System.

## **5. Functional Capability**

The U.S. DoD uses approximately 128 million gallons of jet fuel per year in Hawaii. This BDS must augment 42.9 million gallons per year of this usage with a 50/50



blend of petroleum-based and algae-based jet fuel. The BDS must provide for the blending and conditioning of the fuels and storage, transportation, and distribution of the fuel to the end user.

## **6. Security**

The biofuels distribution system will be a vital component of PACOMs fuel distribution system, and as such, is expected to be a key target in any conventional conflict and has the potential to be targeted by terrorists trying to inflict damage on vital U.S. DoD infrastructure. The biofuel distribution system design shall incorporate necessary security measures, such as cameras and perimeter sensors, to ensure the security and continued operation of the fuel distribution system.

## **7. Service Life**

The Biofuels Distribution System is expected to service PACOM for a minimum of 50 years. The BDS must be designed so that it can handle a 1.5% per year capacity increase over this timeframe, as projected by PACOM. A Failure Mode, Effects, and Criticality Analysis (FMECA), Level of Repair Analysis, and Maintenance Task Analysis will be conducted to identify likely failure modes and the severity of such failures. Attempts will be made during the design phase to minimize the likelihood of severe failures and reduce the number of required spares.

## **8. Maintainability**

Maintainability is the “ability of an item to be retained in or restored to a specified condition when maintenance is performed by personnel having specified skill levels, using prescribed procedures and resources, at each prescribed level of maintenance and repair.” (Hoivik, 2013) The distribution system shall be designed to minimize maintenance times and labor hours while maximizing supportability characteristics by providing automated diagnostic systems, ensuring that typical maintenance items are easily accessible, and using industry-standard components. Maintenance actions will be supported through a range of logistic resources including spares, test equipment, personnel, and facilities (Blanchard et al. 2011, 113).

A Failure Mode, Effects, and Criticality Analysis (FMECA), Level of Repair Analysis (LORA), and Maintenance Task Analysis (MTA) will be conducted to identify likely failure modes and the severity of such failures. Attempts will be made during the design phase to minimize the likelihood of severe failures and reduce the number of required spares.

## **9. Supportability and Serviceability**

The BDS shall be supportable through logistics and manpower. The system shall be designed such that planned logistic resources (spares, repair parts, and documentation) allow for the system to meet peacetime and surge requirements. Support documentation including Operator and Maintainer instructions, Allowance Parts Lists, and software manuals will be delivered upon implementation of the Biofuels Distribution System. Manpower supportability is developed through Human Systems Integration (HSI) and will identify the necessary skills and responsibilities to operate and support the system throughout its lifetime. Implementing HSI will ensure that the operators and maintainers are considered when designing the BDS to ensure that the system can be serviced, ensuring adequate physical access to those components that must be manipulated, inspected, replaced, or repaired. The BDS should be designed to the maximum extent possible to be built, operated, and maintained using local manpower and manufacturing resources.

## **10. Interoperability**

Interoperability is the ability of the system to provide services to and accept services from other systems and to use those services to operate effectively together (Hoivik, 2013). The biofuel distribution system shall be interoperable with the existing infrastructure in Hawaii. Where practical, existing fuel distribution networks will be utilized to the greatest extent possible to minimize the necessity for the addition of new equipment. New pipelines constructed to transport the biofuel will be designed to transport multiple fuel products and incorporate means to physically separate the various fuels during transport.

### **11. Producibility / Constructability and Disposability**

The biofuel distribution system shall be designed to minimize the need for exotic manufacturing processes. To minimize production costs, where feasible, the final design will be producible using standard manufacturing processes, standard tools, and existing equipment. To facilitate rapid and economical disassembly and disposal, the design will minimize the use of hazardous materials both in the product as well as the manufacturing process.

### **12. Reliability**

Reliability is the characteristic of design and installation concerned with the successful operation of the system throughout its planned mission and for the duration of its life cycle. (Blanchard et al. 2011, 112) The biofuels distribution system will be an integral part of PACOMs fuel supply system in Hawaii and as such, its design must maximize operational reliability and minimize system failure while operating under environmental conditions inherent to the Hawaiian Islands. The distribution system shall have a Mean Time Between Failure (MTBF) equal to or better than the existing fuel distribution system.

### **13. Affordability**

Affordability “refers to the characteristics of design and installation that impact total system cost and overall budgetary constraints. (Blanchard et al. 2011, 113–114) The BDS design will minimize the total life-cycle costs of the system, as desired by PACOM. The life-cycle costs include production, maintenance, and disposal costs.

### **14. Availability**

Operational availability is the “probability that a system or equipment, when used under stated conditions in an *actual* operational environment, will operate satisfactorily when called upon.” (Blanchard et al. 2011, 427) Operational availability includes factors such as logistics delay time, administrative delay time, maintenance time, and the frequency of maintenance. The BDS will have an operational availability equal to or greater than the existing military fuel distribution system in Hawaii.

## **F. ENVIRONMENTAL ANALYSIS - TRANSPORTATION**

According to the Interstate Technology & Regulatory Council (ITRC) there are several “conditions” related to the transportation of biofuels that can affect the environment. The ITRC states that the “fate and transport of biofuel in the environment are highly dependent on site conditions, volume and rate of the release, and the fraction of biofuel in the released products. Nonetheless, some key properties of biofuel can provide insight into their fate, transport, and their potential adverse impacts to the environment” (ITRC 2011, 37). Additionally, the ITRC listed the aforementioned properties as follows:

1. Physical-chemical Properties
2. Biodegradation Potential
3. Interactions with other Contaminants (ITRC 2011, 37)

While researching differing properties and implications and the ITRC discovered the following:

As petroleum fuel migrates vertically from the release point, some is trapped in the unsaturated zone. Simultaneously, some of its components partition to the surrounding media (soil, organic material, air, water). Depending on the release scenario (e.g., spill volume, geology, etc.), the petroleum may approach the water table and spread laterally around it (Figure 1) with some vertical migration if a sufficient Light, Non-Aqueous-Phase Liquid (LNAPL) head is present. Following a release, the LNAPL eventually stops spreading laterally, and the footprint becomes stable. Within the LNAPL boundary, or ‘footprint,’ LNAPL may move and redistribute itself with water table fluctuations. (ITRC 2011, 36).

What is represented in Figure 1 from ITRC is reproduced here as Figure 12: it is an illustrative conceptual model of the migration of Light, Non-Aqueous-Phase Liquid (LNAPL) and partitioning of fuel components to media along the migration pathway.

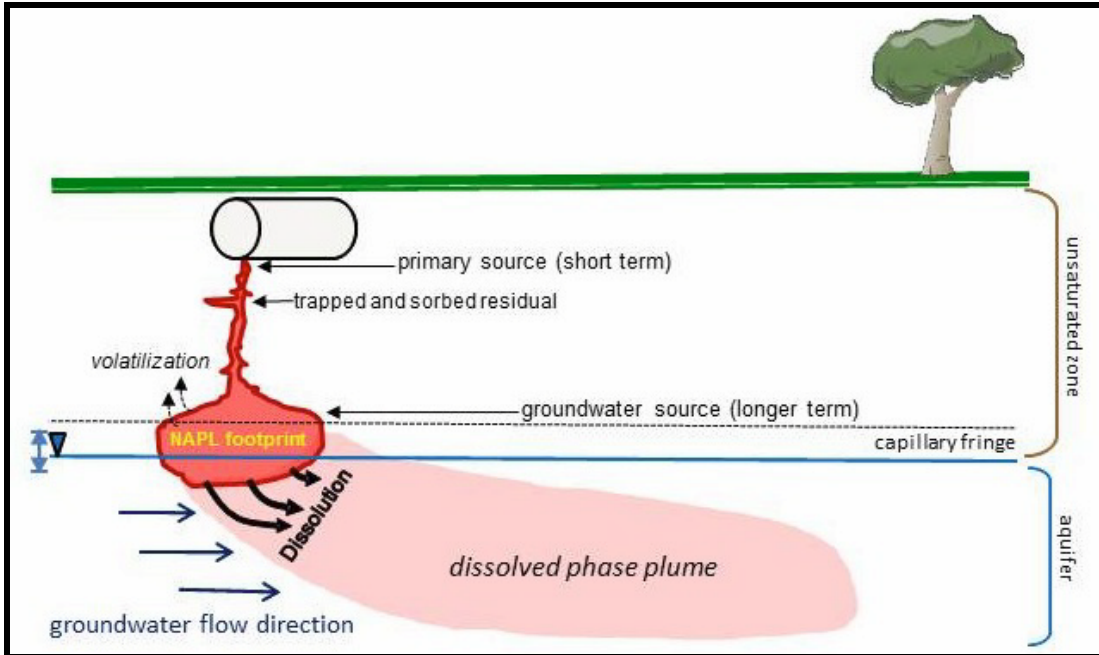

Figure 12. Underground Storage Tank (UST) Fuel Release Concept (From ITRC 2011, 37)

## 1. Physical and Chemical Properties of Biofuels

When comparing biofuels to other alternative fuels options, biofuels possess a number of distinctive qualities and properties. According to the ITRC:

The physical and chemical properties of biofuel components offer insight into their mobility in different environmental media. Phase transfer depends on contact with and partitioning from one media to another (air, water, soil). Fuel components with high vapor pressures tend to rapidly evaporate into the atmosphere. Vapor pressure and Henry's law constant (tendency to partition into vapor phase from dissolved phase) significantly influence the persistence of volatile fuels in ground and surface waters. (ITRC 2011, 37–38)

## 2. Biofuel Interactions with Petroleum Fuels

The ITRC noted that “in general, the higher the fraction of the biofuel in a blend, the lower the content of petroleum hydrocarbons in the environment. Nonetheless, the presence of some petroleum hydrocarbons in released fuels can potentially impact soil or water, and their fate and transport can be influenced by the presence of the biofuel.” (55.)

In the next section, are sections from ITRC where they describe biofuels and their relationship to other potential contaminants.

### **3. Surface Water Fate and Transport**

“Fate” and “Transport Mechanisms” in tandem with “physical,” “chemical” and “biological” properties of biofuels are relevant environment concerns. More specifically, according to the ITRC:

Surface waters include rivers, lakes, ponds, wetlands, estuaries, etc. Under a variety of release scenarios biofuels can enter surface water directly or through conveyances, such as storm drains and ditches. Site-specific characteristics of the water body and the physical, chemical, and biological properties of the biofuel released influence the significance of the fate and transport mechanisms. In stagnant or lower-energy or surface water systems, alcohol releases can form temporary, buoyant, concentrated layers that disperse within the water column. Under these conditions, vaporization could be a significant attenuation mechanism. In higher-energy, fast-flowing waters or with significant wave action, alcohols are quickly diluted and attenuation may primarily occur by biodegradation, which places a significant oxygen demand on the water body. Under these conditions, attenuation rates depend on the influx of atmospheric oxygen. (ITRC 2011 46–47)

All of the aforementioned characteristics may cause serious concern for the various stakeholders associated with the BDS as they relate to the state of the environment. Additionally, these characteristics will be concerns that relate particularly to the transportation and storage of algae-based biofuels.

### **4. Vadose Zone Fate and Transport**

As depicted in Figure 13, “Ethanol may readily partition into pore water along its migration pathway or migrate as a bulk fuel. The darker red shading indicates greater NAPL pore saturations; yellow indicates the extent of detectable ethanol prior to dilution and attenuation. As ethanol reduces the surface tension in the pores, increased drainage can occur. However, much of the ethanol will be retained in soil with low conductivities.” (ITRC 2011, 47)

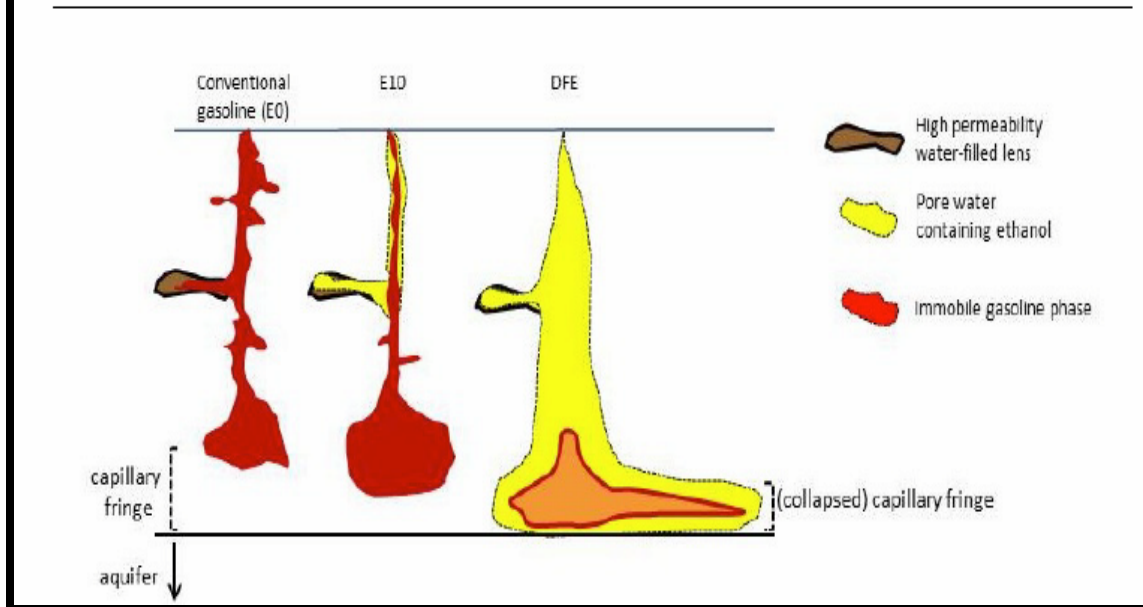

Figure 13. Non-Aqueous Phase Liquid (NAPL) Distributions of Fuels. (From ITRC 2011, 48)

## 5. Saturated Zone Fate and Transport

Another important area in terms of the environmental constraints as they relate to biofuels is that “Saturated Zone Fate and Transport.” The ITRC defines the saturated zone as “the area below the water table where all pore spaces are filled with water under pressure equal to or greater than that of the atmosphere.” (IRTC 2011, 48) The ITRC also states “For chemicals to adversely impact groundwater, contaminants must enter the aquifer, reach concentrations of concern, and persist long enough to be a concern for potential receptors (such as a drinking water supply well or surface water discharge). Ethanol in ground water has been investigated at several experimental sites and a few Denatured Fuel Ethanol (DFE) release sites.” (IRTC 2011, 48)

Additionally, the Government Accountability Office determined the following in relation to biofuels and environmental constraints:

1. Increased Biofuels Production Could Have a Variety of Environmental Effects, but the Magnitude of These Effects Is Largely Unknown

2. Cultivation of Corn for Biofuel Has a Variety of Environmental Effects, but a Shift to Cellulosic Feedstocks Could Reduce These Effects
3. Increased Cultivation of Corn for Ethanol Could Further Stress Water Supplies, but Cultivation of Certain Cellulosic Feedstocks May Require Less Water
4. Increased Corn Cultivation for Biofuels Is Likely to Impair Water Quality, but Cultivation of Certain Cellulosic Feedstocks May Have Less of an Effect.
5. Biofuels Production Can Affect Soil Quality and Productivity
6. Habitat and Biodiversity May be Compromised with the Increased Biofuel Feedstocks Cultivation
7. The Process of Converting Feedstocks into Biofuels Has Environmental Consequences, but the Effects Vary
8. Water Pollutants Discharged by Biorefineries Are Regulated under the Existing Permitting Process
9. Air Quality Effects of Biofineries Will Depend on the location and Size of the Facility and the Feedstock Used
10. Storage and Use of Certain Ethanol Blends May Result in Further Environmental Effects that Have Not Yet Been Measured
11. Current Fuel Storage and Delivery Infrastructures May be Inadequate to Prevent Leaks and Potential Groundwater Contamination from Certain Ethanol Blends
12. Use of Certain Ethanol Blends in Vehicles Is Expected to Increase Emissions of Certain Air Pollutants, but Research Is Ongoing to Better Establish the Magnitude of These Emissions (GAO 2009, 55–75)

## **6. General State, Local and Federal Laws (Environmental)**

The BDS must comply with all applicable state, local and federal laws governing the production, storage handling and transportation of fuel products. The specific laws and regulations that may apply to the BDS are outlined below:

## **7. Applicable Environmental Laws and Regulations Overviews**

### *a. NEPA*

The National Environmental Policy Act was established in order to give strong consideration to aspects that may affect the environment as they relate to planning and action of Federal Agencies. More specifically, the EPA states that the “NEPA requires federal agencies to incorporate consideration in their planning and decision-making in tandem with the preparation of detailed statements that assess the environmental impact of activities and alternatives that significantly affect the environment” (EPA 2008, 12). Additionally, the EPA states the following in reference to biofuel production: Production of biofuels contribute emissions to the air including volatile organic compounds, sulfur dioxide, nitrogen oxides, hazardous air pollutants and particulate matter, all of which are required to be controlled by applicable regulations. (EPA 2008, 12)



When distributing algae-based biofuels, the DoD will be required to exercise due diligence and care in terms of the environment and the precepts that NEPA outlines. Additionally, the DoD will need to evaluate the level of emissions algae-based biofuels could produce based on the volume and frequency of production.

***b. Clean Water Act (CWA)***

Compliance with the Clean Water act ultimately helps facilitate the consistency of the sanitization of surface water. The Clean Water Act is summarized below:

The Clean Water Act (CWA) establishes the basic structure for regulating discharges of pollutants into the waters of the United States and regulating quality standards for surface waters. The basis of the CWA was enacted in 1948 and was called the Federal Water Pollution Control Act, but the Act was significantly reorganized and expanded in 1972. “Clean Water Act” became the Act’s common name with amendments in 1972. Under the CWA, EPA has implemented pollution control programs such as setting wastewater standards for industry. We have also set water quality standards for all contaminants in surface waters. The CWA made it unlawful to discharge any pollutant from a point source into navigable waters, unless a permit was obtained. EPA’s National Pollutant Discharge Elimination System (NPDES) permit program controls discharges. Point sources are discrete conveyances such as pipes or man-made ditches. Individual homes that are connected to a municipal system, use a septic system, or do not have a surface discharge do not need an NPDES permit; however, industrial, municipal, and other facilities must obtain permits if their discharges go directly to surface waters. (EPA 2008, 13)

When distributing algae-based biofuels, the DoD will be required to exercise due diligence and care in terms of the environment and the precepts that CWA outlines. Additionally, the DoD will need to evaluate the level contaminants and pollutants that algae-based biofuels could produce based on the volume and frequency of production.

***c. Safe Drinking Water Act (SDWA)***

Compliance with the SWDA can help ensure that the quality of drinkable and/or potable water is constant. The SWDA is outlined by the EPA below:

The Safe Drinking Water Act (SDWA) is the main federal law that ensures the quality of Americans' drinking water. Under SDWA, EPA sets standards for drinking water quality and oversees the states, localities, and water suppliers who implement those standards. SDWA was originally passed by Congress in 1974 to protect public health by regulating the nation's public drinking water supply. The law was amended in 1986 and 1996 and requires many actions to protect drinking water and its sources: rivers, lakes, reservoirs, springs, and ground water wells. (SDWA does not regulate private wells, which serve fewer than 25 individuals.) SDWA authorizes the United States Environmental Protection Agency (U.S. EPA) to set national health-based standards for drinking water to protect against both naturally-occurring and man-made contaminants that may be found in drinking water. U.S. EPA, states, and water systems then work together to make sure that these standards are met. (EPA 2008, 16)

When distributing algae-based biofuels, the DoD will be required to exercise due diligence and care in terms of the environment and the precepts that SDWA outlines. Additionally, the DoD will need to evaluate the level contaminants and pollutants that algae-based biofuels could produce based on the volume and frequency of production and how this production could affect the quality of potable water.

*d. Clean Air Act (CAA)*

“The Clean Air Act is the law that defines EPA's responsibilities for protecting and improving the nation's air quality and the stratospheric ozone layer.” (EPA 2008, 1). The Clean Air Act contains six sections that address specific environmental aspect and are outlined below:

- Title I - Air Pollution Prevention and Control
  - Part A - Air Quality and Emission Limitations (CAA § 101–131; USC § 7401–7431)
  - Part B - Ozone Protection (replaced by Title VI)
  - Part C - Prevention of Significant Deterioration of Air Quality (CAA § 160–169b; USC § 7470–7492)
  - Part D - Plan Requirements for Nonattainment Areas (CAA § 171–193; USC § 7501–7515)
- Title II - Emission Standards for Moving Sources
  - Part A - Motor Vehicle Emission and Fuel Standards (CAA § 201–219; USC § 7521–7554)
  - Part B - Aircraft Emission Standards (CAA § 231–234; USC § 7571–7574)
  - Part C - Clean Fuel Vehicles (CAA § 241–250; USC § 7581–7590)

- Title III - General (CAA § 301–328; USC § 7601–7627)
- Title IV - Acid Deposition Control (CAA § 401–416; USC § 7651–7651o)
- Title V - Permits (CAA § 501–507; USC § 7661–7661f)
- Title VI - Stratospheric Ozone Protection (CAA § 601–618; USC § 7671–7671q)  
(EPA 2008, 21)

When distributing algae-based biofuels, the DoD will be required to exercise due diligence and care in terms of the environment and the precepts that CAA outlines. Additionally, the DoD will need to evaluate the level contaminants and pollutants that algae-based biofuels could produce based on the volume and frequency of production and how this production could affect the quality of air and the ozone layer.

*e. Resource Conservation and Recovery Act (RCRA)*

Waste can potentially have a negative effect on human health and the environment. In order to protect the health of humans and the environment the RCRA was established, implemented and organized. The EPA states the following in reference to the RCRA:

The objectives of the Resource Conservation and Recovery Act (RCRA) are to protect human health and the environment from the potential hazards of waste disposal, to conserve energy and natural resources, to reduce the amount of waste generated, and to ensure that wastes are managed in an environmentally sound manner. RCRA regulates the management of solid waste (e.g., garbage), hazardous waste, and underground storage tanks holding petroleum products or certain chemicals. (EPA 2008, 36)

Additionally, the RCRA addresses the following environmental aspects as they relate to humans and the environment:

- Solid Waste and Hazardous Waste
- Universal Waste
- Used Oil Management Standards
- Underground Storage Tanks
- Hazardous Waste and Agriculture
- Universal Waste and Agriculture
- Used Oil and Agriculture
- Underground Storage Tanks and Agriculture (EPA 2008, 36)

When distributing algae-based biofuels, the DoD will be required to exercise due diligence and care in terms of the environment and the precepts that RCRA outlines. Additionally, the DoD will need to evaluate the type and level waste that algae-based biofuels could produce based on the volume and frequency of production in tandem how this production could affect the health of human beings.

*f. Pollution Prevention Act (PPA)*

The prevention of pollution is a pro-active method of preventing the contamination of the environment via toxic waste or other entities with similar characteristics. The PPA was enacted to support the aforementioned method that can ultimately help ensure the environment is free of pollutants and contamination. The EPA summarizes the PPA in detail below:

The Pollution Prevention Act focused industry, government, and public attention on reducing the amount of pollution through cost-effective changes in production, operation, and raw materials use. Opportunities for source reduction are often not realized because of existing regulations, and the industrial resources required for compliance, focus on treatment and disposal. Source reduction is fundamentally different and more desirable than waste management or pollution control. Source reduction refers to practices that reduce hazardous substances from being released into the environment prior to recycling, treatment or disposal. The term includes equipment or technology modifications, process or procedure modifications, reformulation or redesign of products, substitution of raw materials, and improvements in housekeeping, maintenance, training, or inventory control. Pollution prevention includes practices that increase efficiency in the use of energy, water, or other natural resources, and protect our resource base through conservation. (EPA 2008, 37)

When distributing algae-based biofuels the DoD will be required to exercise due diligence and care in terms of the environment and the precepts that PPA outlines. Additionally, the DoD will need to evaluate the level pollution that algae-based biofuels could produce based on the volume and frequency of production in a pro-active manner.

***g. Toxic Substance Control Act (TSCA)***

The TSCA addresses the accountability in terms of documentation, testing and restrictions related to chemical substances in the original form and mixtures (e.g., new or existing). (EPA 2008, 40) In terms of the TSCA the EPA states the following:

The Toxic Substances Control Act of 1976 provides EPA with authority to require reporting, record-keeping and testing requirements, and restrictions relating to chemical substances and/or mixtures. Certain substances are generally excluded from TSCA, including, among others, food, drugs, cosmetics and pesticides. TSCA addresses the production, importation, use, and disposal of specific chemicals including polychlorinated biphenyls, asbestos, radon and lead-based paint. (EPA 2008, 40)

Moreover, in order to be in compliance with the TSCA specific reporting requirements are required:

- Potential Submitters are required to submit a bona fide notice of intent to manufacture or import a chemical substance to the EPA in order to determine if the chemical is listed on the confidential TSCA inventory. The EPA states that most Biofuels “Are processed in a way that they do not fit the “naturally occurring” criterion of the TSCA inventory. Conversely, some biofuels will be made using techniques, such as metabolic engineering, that require the use of inter-generic microbes, thus making the microbes subject to TSCA. Biofuels generally would fit a classification called “Unknown Variable Compositions (UVCBs), Complex Reaction Products and Biological Materials.” (TSCA 2008, 40)
- Anyone who plans to manufacture or import a new chemical substance for a non-exempt commercial purpose is required by Section 5 of the TSCA to provide EPA with notice before initiating the activity. This Pre-manufacture Notice, must be submitted 90 days prior to the manufacture or import of the chemical.
- The EPA has limited or no reporting requirements for new chemical substances in the following cases: low volumes (less than 10,000 kilograms per year), low releases and exposures, test marketing, polymers, research and development. (EPA 2008, 41)

## **8. Environmental Summary**

The transportation of biofuels could potentially have a variety of effects on the local and regional environment. Nonetheless, organizations like the EPA, GAO and ITRC are working in tandem to ensure that due care and diligence are adhered to in terms of environmental aspects that relate to biofuels. This due care and diligence is provided via a high level of oversight and strict policy that is tailored to protect the environment and human life. These general local state and federal laws provide guidelines in tandem with various policies that are designed to reduce the impact of the transportation of biofuels as they relate to the environment and human life.

### **G. BIOFUELS SYSTEM ANALYSIS SUMMARY**

The overall System Analysis consisted of the Stakeholder Analysis, Operational Concept Design, Context Model, Value System Modeling, Requirements Analysis, and Environmental Analysis. The Stakeholder Analysis identified the major stakeholders, engaged them in the project, and provided the basis of information that was used in modeling and simulation, analysis of alternatives, risk analysis, and environmental study. The Operational Concept Design focused on translating primitive need into effective need. It identified the primitive need as the global need for fuel, which was used to initiate the development of the BDS concept. The Biofuels team developed the Context Model to further examine the scope of the BDS system, set system boundaries, identify external operational nodes, and define key relationships between the system and external systems or factors. Value System Modeling provided the framework for the stakeholders' objectives and requirements. Additionally, Value System Modeling mapped the system capabilities and performance to the needs of the stakeholders. The Requirements Analysis identified the requirements of the system and defined each of them based on the needs of the stakeholders. The Environmental Analysis identified potential environmental hazards related to biofuel distribution to the consumers.

THIS PAGE INTENTIONALLY LEFT BLANK

## **IV. PRELIMINARY DESIGN**

The preliminary design phase develops the preferred system concept and demonstrates that this concept fulfills the system design requirements. Activities contained within this phase include functional analysis and allocation, analysis of alternatives, and modeling and simulation. (Blanchard et al. 2011).

### **A. FUNCTIONAL ANALYSIS**

This section describes the functional identification, decomposition, resources, and interfaces of the BDS. These products are synthesized into a functional architecture that was used as a functional baseline for further design and physical allocation.

#### **1. General Approach**

The BDS is a complex system that necessitated the use of Model-Based Systems Engineering (MBSE). MBSE is the application of modeling techniques to “support system requirements, design, analysis, verification, and validation” (Crisp 2007, 15). MBSE facilitates rapid system synthesis by utilizing accepted standards and a wide range of modeling libraries to produce a comprehensive system description in a language that can span across all engineering domains. Of the wide variety of accepted MBSE tools, the Biofuels Team used CORE to develop the functional architecture of the BDS. The team’s general approach was to capture system requirements, translate those requirements to functions, allocate those functions to physical components, and define system functional and physical interfaces between internal system components and functions and external entities. The end result of this process was a functional architecture that defined the logical behavior and performance characteristics of the BDS system. Figure 14 outlines and depicts the process in detail.



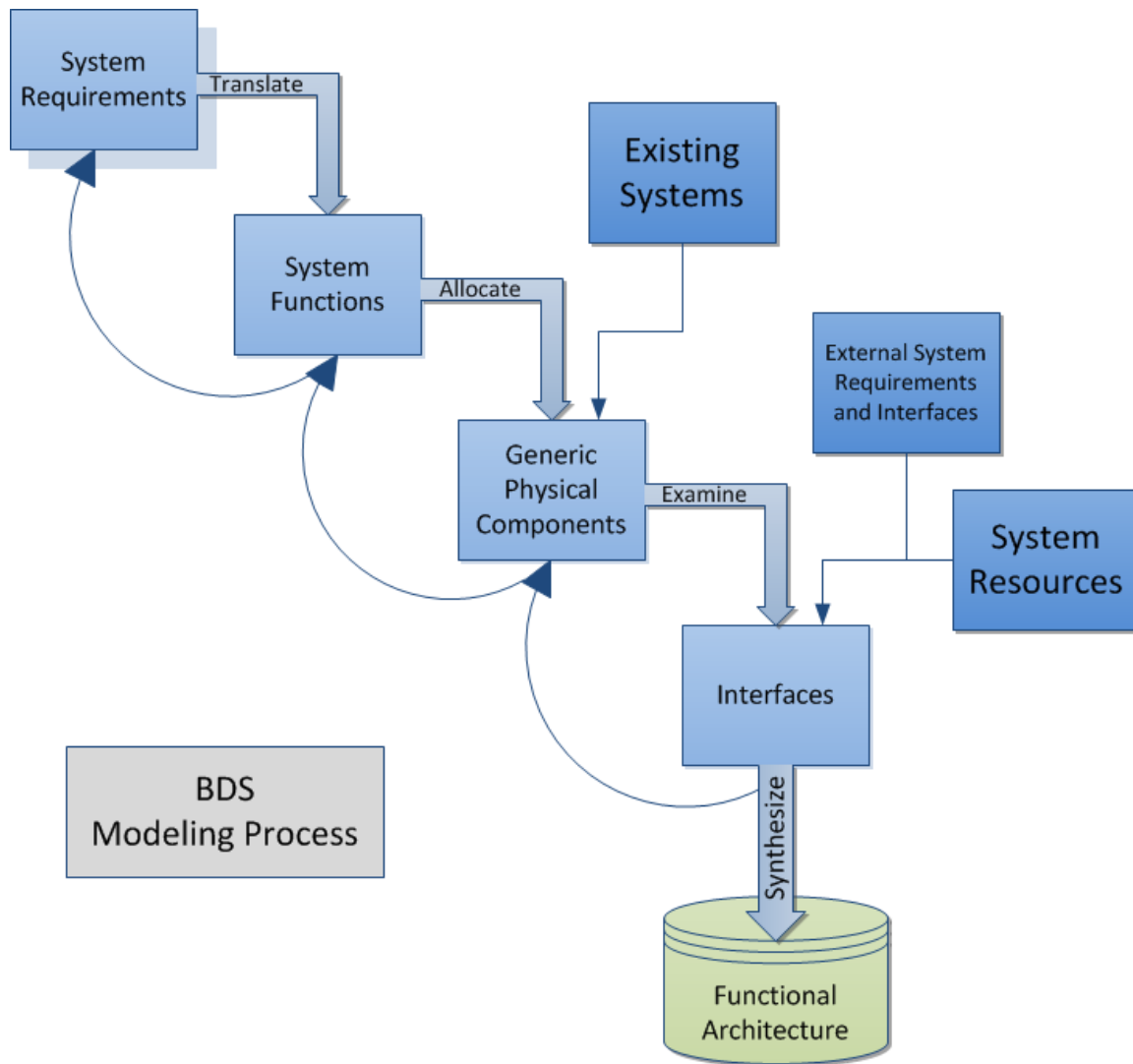

Figure 14. MSBE Modeling Process

## 2. Functional Identification and Decomposition

The primary system function of the BDS, derived from the originating requirement, is to provide biofuel to the customer. Figure 15 shows the relationship of the primary function, 1.6, to the external system functions.

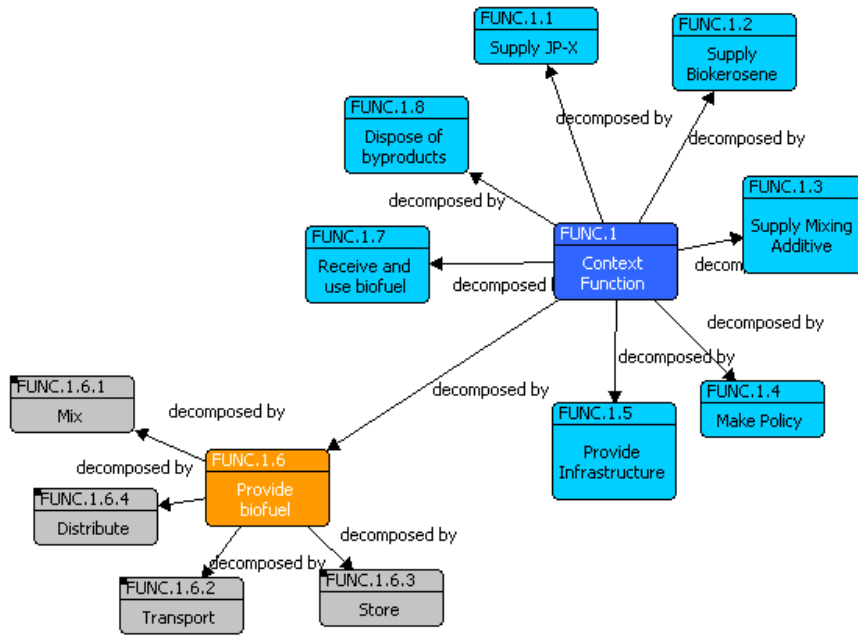

Figure 15. Function Comparison

The primary system function was then decomposed to four top-level functions: Mix, Transport, Store, and Distribute. Each top-level function was then decomposed further to the lowest level and a functional hierarchy was developed. This allowed for traceability of system requirements down to the most basic functions of the system.

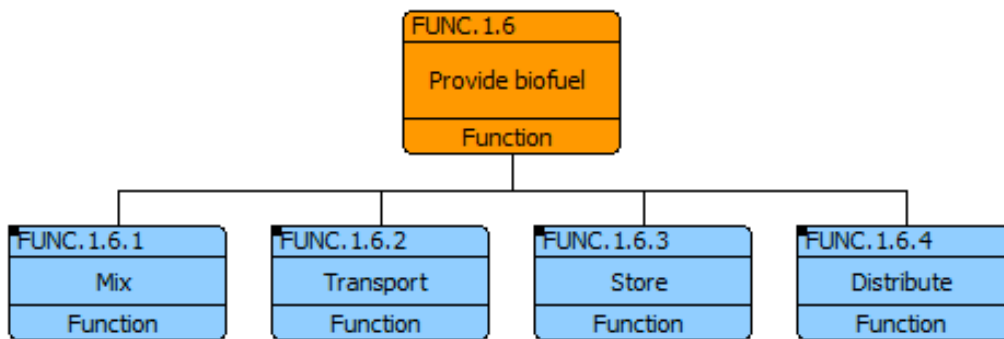

Figure 16. Four Top-Level Functions

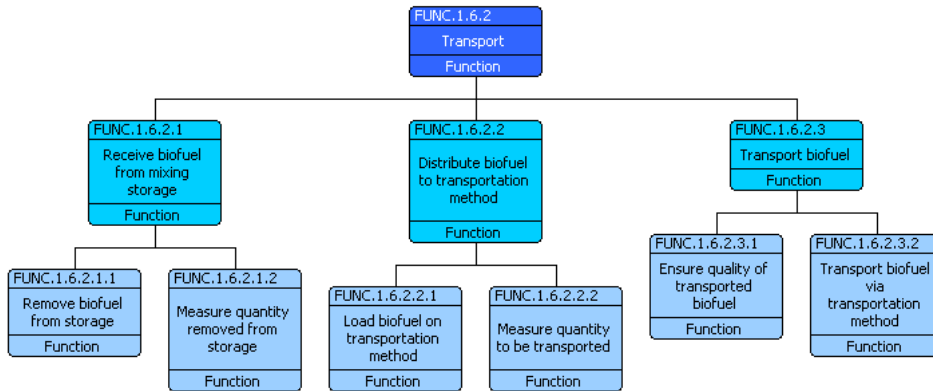
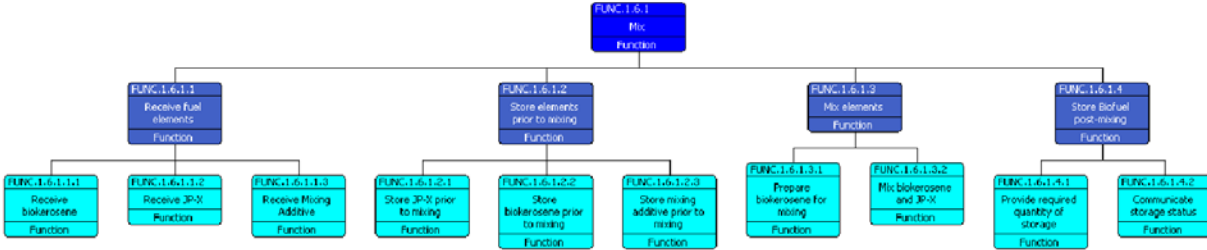

Figure 17. Functional Decomposition (Part 1, 2)

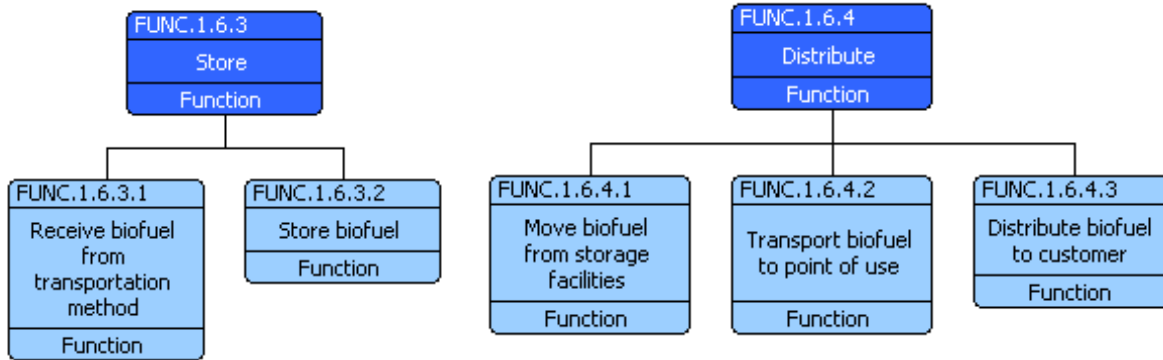

Figure 18. Functional Decomposition (Part 3, 4)

### 3. Functional Flow Block Diagrams

After the functions were identified and decomposed into ordered hierarchies, the interrelationships of the functions were specified. This was accomplished using the Enhanced Functional Flow Block Diagram (EFFBD) tool within CORE. EFFBDs “identify and show the relationships of system functions and sub-functions.” (Parnell et al. 2010, 317) EFFBDs do not, however, define system interfaces or resources, which are necessary to complete the functional architecture (Parnell et al. 2010, 317). Figure 19 is an EFFBD for the Context Function, which gives an overall view of the system’s relationship with the various inputs, outputs, resources, and external systems. Figure 20 is the EFFBD for the primary system function *Provide Biofuel* and shows a high-level view of the system inputs, outputs, and resources. Further EFFBDs are found in Appendix B.

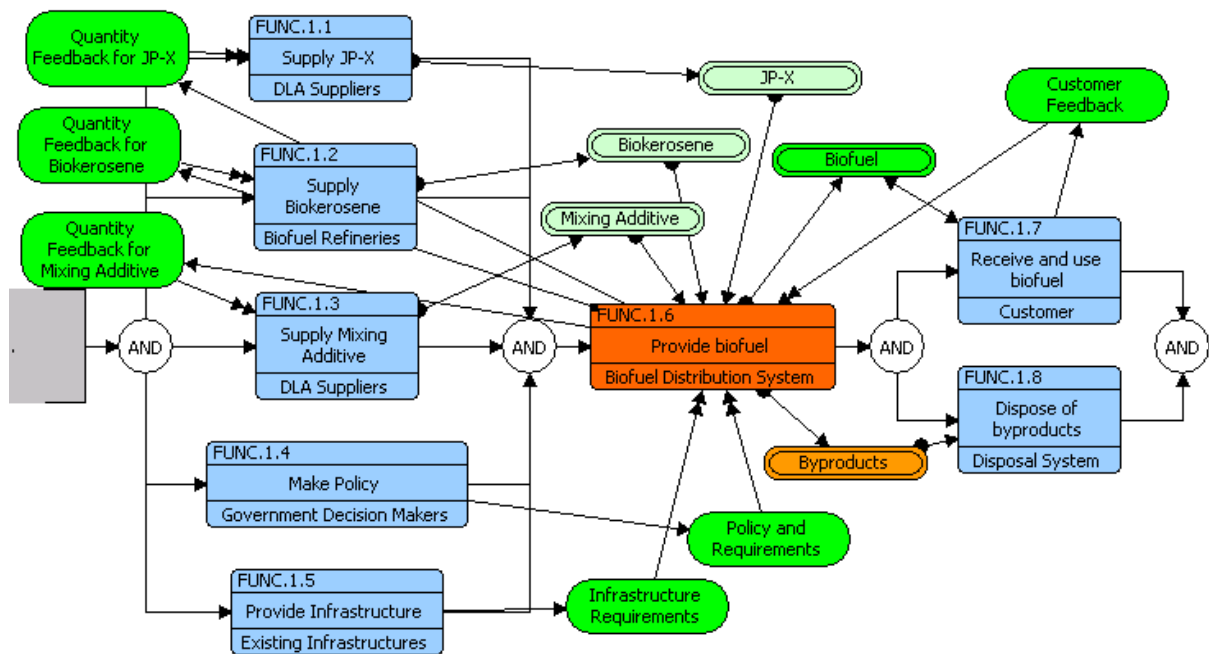

Figure 19. CORE EFFBD Overall View

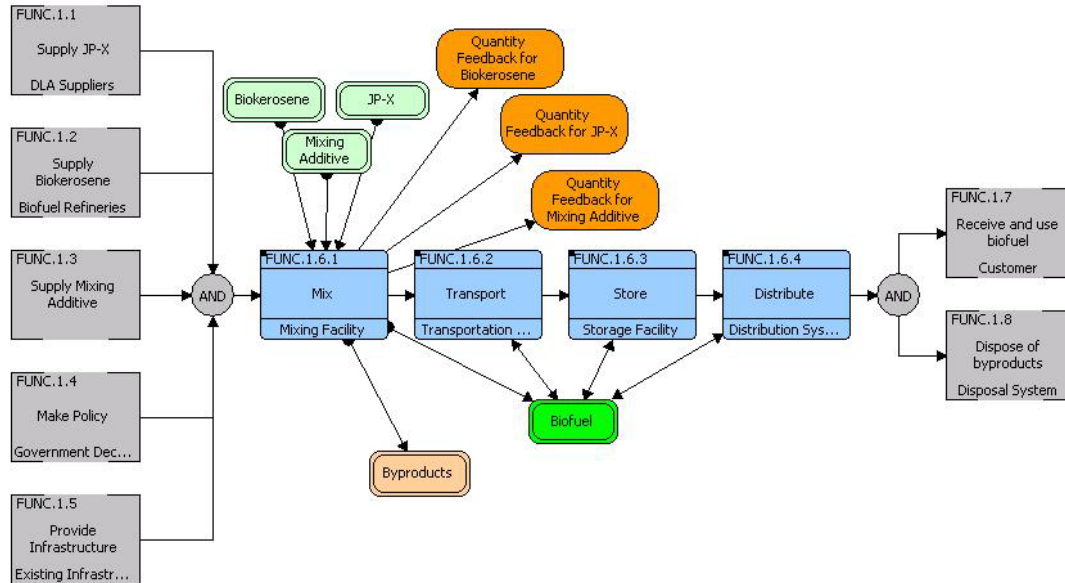

Figure 20. CORE EFFBD High-Level View of Inputs, Outputs and Resources

### a. System Resources

The major function of a distribution system is to receive and move resources to a selected location and state. To do this, system resources were identified by research and subject matter expert engagement. Each resource was defined in terms of its origination point (internal or external), composition, and relationships in terms of functional behavior. A list of BDS resources is provided below and defined further in the Appendix B.

- Biofuel
- JP-X
- Biokerosene
- Mixing Additive
- Prepared Biokerosene
- Byproducts

### b. System Interfaces

A key component to a functional architecture is the definition of internal and external interfaces. These interfaces can transfer physical objects (such as

fuel) or logical objects (such as data). The team first identified any exterior system or group that must interface with the system and developed those interfaces within CORE. Next, those exterior interfaces were linked down to the lowest physical component and functions to fully describe them. Lastly, the internal components and function interfaces were examined and defined. Table 4 defines all interfaces of the BDS

Name	Number & Name	Description	connects to
Biofuel Output Link	LINK.1 Biofuel Output Link	Link to allow output of refined 50/50 biofuel from BDS to the customer.	COMP.1.1 Biofuel Distribution System COMP.1.2 Customer
Biokerosene Feedback Link	LINK.2 Biokerosene Feedback Link	Link from BDS to Biofuel refineries to communicate demand for biokerosene based on BDS system usage.	COMP.1.1 Biofuel Distribution System COMP.1.4 Biofuel Refineries
Biokerosene Input Link	LINK.3 Biokerosene Input Link	Link to allow output of biokerosene from Bio-refinery to BDS.	COMP.1.1 Biofuel Distribution System COMP.1.4 Biofuel Refineries
Byproduct Output Link	LINK.4 Byproduct Output Link	Link to allow output of hazardous byproducts that may result from the mixing process to the disposal system.	COMP.1.1 Biofuel Distribution System COMP.1.3 Disposal System
Customer Feedback Link	LINK.5 Customer Feedback Link	Link from the customer to the BDS to communicate any feedback or usage requirements.	COMP.1.1 Biofuel Distribution System COMP.1.2 Customer requirements.
Infrastructure Requirements Link	LINK.6 Infrastructure Requirements Link	Link from any existing infrastructure systems to communicate requirements to the BDS.	COMP.1.1 Biofuel Distribution System COMP.1.5 Existing Infrastructures
JP-X Feedback Link	LINK.7 JP-X Feedback Link	Link from BDS to DLA suppliers to communicate required quantities of JP-X based on system usage.	COMP.1.1 Biofuel Distribution System COMP.1.7 DLA Suppliers
JP-X Input Link	LINK.8 JP-X Input Link	Link from DLA suppliers to BDS to allow for transfer of JP-X for use in BDS.	COMP.1.1 Biofuel Distribution System COMP.1.7 DLA Suppliers
Mixing Additive Feedback Link	LINK.9 Mixing Additive Feedback Link	Link from BDS to communicate required quantities of mixing additive.	

Table 4. BDS Interfaces

*c. Allocation*

After system interfaces were identified and defined, functions were mapped to generic physical elements. Given the operational concept definition constraint that the system must be operational by 2020, only existing physical components were considered. Development of new technologies and physical elements will exceed the deployment time constraints. Therefore, generic physical elements were used to complete the logical architecture of the BDS. Generic physical elements were used to complete the logical architecture of the BDS. Further instantiation of the physical components were left for a future design phase and is outside the scope of this project. Table 5 is a list of the generic physical components allocated to the functions they perform.

<b>Number &amp; Name</b>	<b>Performs</b>
COMP.1 System Boundary	FUNC.1 Context Function
COMP.1.1 Biofuel Distribution System	FUNC.1.6 Provide biofuel
COMP.1.1.1 Mixing Facility	FUNC.1.6.1 Mix FUNC.1.6.1.1.2 Receive JP-X FUNC.1.6.1.1.3 Receive Mixing Additive FUNC.1.6.1.2.1 Store JP-X prior to mixing FUNC.1.6.1.2.2 Store biokerosene prior to mixing FUNC.1.6.1.2.3 Store mixing additive prior to mixing FUNC.1.6.1.3 Mix elements FUNC.1.6.1.3.1 Prepare biokerosene for mixing FUNC.1.6.1.3.1.1 Mix biokerosene and mixing additive FUNC.1.6.1.4.1 Provide required quantity of storage FUNC.1.6.1.4.2 Communicate storage status
COMP.1.1.1.1 Biofuel Mixing Tank	FUNC.1.6.1.3.2 Mix biokerosene and JP-X
COMP.1.1.1.2 Biokerosene Prep Tank	FUNC.1.6.1.1.1 Receive biokerosene FUNC.1.6.1.2 Store elements prior to mixing
COMP.1.1.1.3 Biokerosene Pre-Mix Storage Tank	FUNC.1.6.1.1 Receive fuel elements FUNC.1.6.1.1.1 Receive biokerosene FUNC.1.6.1.2 Store elements prior to mixing FUNC.1.6.1.2.2 Store biokerosene prior to mixing
COMP.1.1.1.4 JP-X Pre-Mix Storage Tank	FUNC.1.6.1.1 Receive fuel elements FUNC.1.6.1.1.2 Receive JP-X FUNC.1.6.1.2 Store elements prior to mixing FUNC.1.6.1.2.1 Store JP-X prior to mixing
COMP.1.1.1.5 Mixing Additive Pre-Mix Storage Tank	FUNC.1.6.1.1 Receive fuel elements FUNC.1.6.1.1.3 Receive Mixing Additive FUNC.1.6.1.2 Store elements prior to mixing FUNC.1.6.1.2.3 Store mixing additive prior to mixing
COMP.1.1.1.6 Post-Mixing Storage Tank	FUNC.1.6.1.4 Store Biofuel post-mixing
COMP.1.1.2 Distribution System	FUNC.1.6.4 Distribute FUNC.1.6.4.3 Distribute biofuel to customer



<b>Number &amp; Name</b>	<b>Performs</b>
COMP.1.1.2.1 Distribution Method	FUNC.1.6.4.2 Transport biofuel to point of use
COMP.1.1.2.2 Loading Facility	FUNC.1.6.4.1 Move biofuel from storage facilities FUNC.1.6.4.3 Distribute biofuel to customer
COMP.1.1.3 Storage Facility	FUNC.1.6.3 Store
COMP.1.1.3.1 Storage Tank	FUNC.1.6.3.2 Store biofuel
COMP.1.1.3.2 Storage Tank Interface	FUNC.1.6.3.1 Receive biofuel from transportation method
COMP.1.1.4 Transportation System	FUNC.1.6.2 Transport FUNC.1.6.2.1 Receive biofuel from mixing storage FUNC.1.6.2.1.1 Remove biofuel from storage FUNC.1.6.2.1.2 Measure quantity removed from storage FUNC.1.6.2.2 Distribute biofuel to transportation method FUNC.1.6.2.2.1 Load biofuel on transportation method FUNC.1.6.2.2.2 Measure quantity to be transported FUNC.1.6.2.3 Transport biofuel FUNC.1.6.2.3.2 Transport biofuel via transportation method
COMP.1.1.4.1 Transportation Loading Facility	FUNC.1.6.2.2 Distribute biofuel to transportation method FUNC.1.6.2.2.1 Load biofuel on transportation method
COMP.1.1.4.2 Transportation Method	FUNC.1.6.2.3 Transport biofuel FUNC.1.6.2.3.2 Transport biofuel via transportation method
COMP.1.1.4.3 Transportation Unloading Facility	FUNC.1.6.3.1 Receive biofuel from transportation method
COMP.1.2 Customer	FUNC.1.7 Receive and use biofuel
COMP.1.3 Disposal System	FUNC.1.8 Dispose of byproducts
COMP.1.4 Biofuel Refineries	FUNC.1.2 Supply biokerosene
COMP.1.5 Existing Infrastructures	FUNC.1.5 Provide infrastructure
COMP.1.6 Government Decision Makers	FUNC.1.4 Make policy

Number & Name	Performs
COMP.1.7 DLA Suppliers	FUNC.1.1 Supply JP-X FUNC.1.3 Supply mixing additive

Table 5. Functional Allocation

Similar to the functional interface definition and identification presented above, physical external interfaces were identified and defined. The existing Concept Model was used as a starting point for this analysis. The results are depicted in Figure 21.

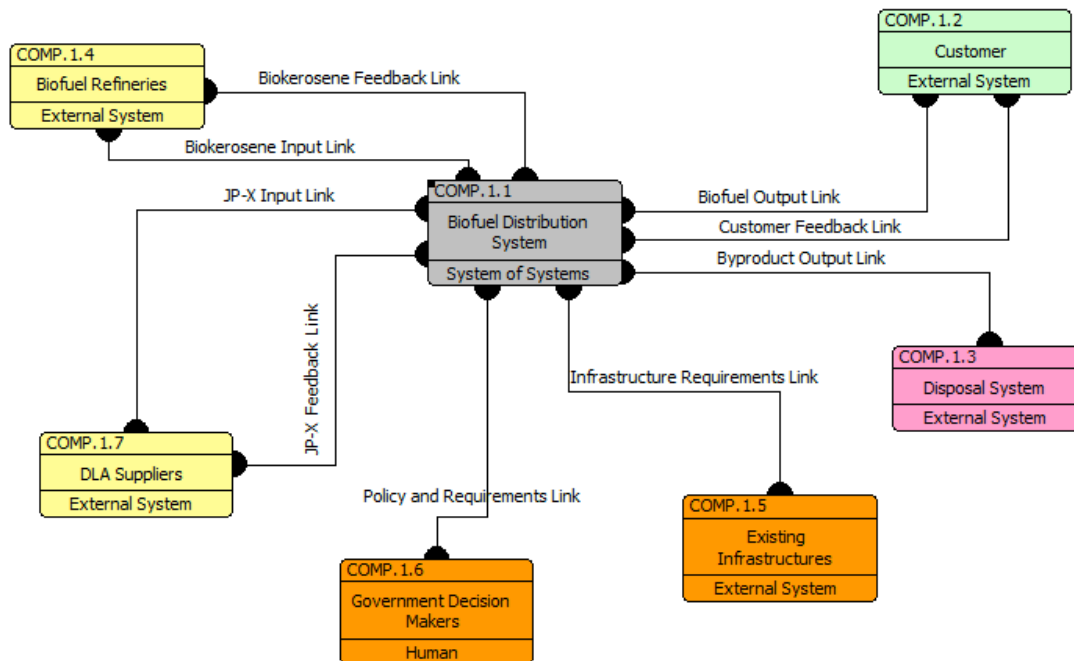

Figure 21. System External Relationships

## B. ANALYSIS OF ALTERNATIVES

### Alternative Development

The first step in determining the best solution for the mixing, transportation, storage and distribution of the biofuel is to determine the best course of

action to manage risk and optimize costs set forth by the DoD. Creative thinking allowed the design space to be expanded ensuring that we considered all potential solutions. The team used brainstorming as the primary creative thinking tool. Brainstorming was developed in the 1930s and focuses on gathering a list of ideas spontaneously contributed by the group's members (Goodwin and Wright 2010, 295). According to Goodwin and Wright, in order for the brainstorming techniques to be effective four basic rules needed to be followed (Goodwin and Wright 2010, 295):

1. *Do not criticize ideas* – the solution to the problem may turn out to lie in an idea that initially, may seem to be crazy.
2. *Encourage participants to put forward any idea that they can think of* – particularly unconventional or outlandish ideas.
3. *Aim to generate large quantities of ideas* – in that way there is a greater chance that one or more of the ideas will lead to a solution to the problem.
4. Encourage people to combine or modify ideas that have already been put forward.

Alternatives were generated through the use of research and subject matter expert engagement and an initial list of five alternatives were generated. Because it was not feasible to investigate and conduct tradeoff analysis on all potential solutions, the list of alternatives was screened for feasibility against MOEs and MOPs and a smaller set of solution alternatives was produced.

After brainstorming various system configurations and taking into consideration the stakeholder preferences and operational need, the team decided that the method of transportation used in the system was the primary variable among the various alternatives. *Provide Transportation* was the most important function identified by the stakeholder during our value modeling process. In order to ensure that we included the entire solution space, all transportation methods were considered regardless of feasibility or cost. This resulted in five primary system configurations:

- Truck Alternative
- Pipeline Alternative
- Barge Alternative
- Rail Alternative

- Combined Alternative

Each of these alternatives listed below uses a separate transportation method to fulfill the function to move biofuel from the refinery to storage.

**Truck Alternative:** The truck alternative concept utilizes existing fuel transport vehicles to move the biofuel from the refinery to the three military bases, MCBH, Wheeler Army Airfield, and Pearl Harbor-Hickam. This system concept involves sending trucks from the refineries located in Kapolei along H1 to Pearl Harbor-Hickam, H2 to Wheeler Army Airfield, and H3 to MCBH. The biofuel is then offloaded to the respective base's existing fuel storage system and distributed to the point of use.

**Pipeline Alternative:** The pipeline alternative concept utilizes a dedicated biofuel pipeline from the refineries directly to the three military base's storage system. These pipelines do not currently exist to MCBH or Wheeler Army Airfield and must be constructed to fulfill the requirements of the system.

**Barge Alternative:** The barge alternative concept utilizes an existing fleet of inter-island fuel barges to move fuel directly from the refinery area to MCBH and Pearl Harbor-Hickam. As Wheeler Army Airfield is not accessible by water, biofuel would not be provided with this concept.

**Rail Alternative:** The rail alternative utilizes existing rail lines from Kapolei to Pearl Harbor-Hickam to transport biofuel. Rail lines do not exist to MCBH or Wheeler Army Airfield and would need to be constructed to fulfill the requirements of the system.

**Combined Alternative:** This alternative utilizes an existing pipeline from Kapolei to the Red Hill fuel storage facility. Biofuel is then moved via existing fuel transportation vehicles to MCBH and Wheeler Army Airfield and underground tunnels to Pearl Harbor-Hickam via pipelines.

A basic trade-off analysis was conducted for our project centered primarily on distribution and transportation methods in order to most effectively get the fuel from the refinery to the customer. In order to conduct the analysis we utilized the following tradeoffs:

1. Speed / Time of delivery
2. Total Capacity
3. En-route delays (Traffic / Sea States)

Of the alternatives listed above the Barge has one of the largest capacities but has a trade-off in speed due to the slow rate of travel and larger distance travelled to reach the farthest military installation. The barge method also is limited in that it is unable to provide fuel to the inland military bases, therefore it was screened for feasibility. Oahu's geographic characteristics do not allow for easy construction of a rail system and an existing system is not currently in place. Due to this and the system's time constraint, the rail alternative was determined to be infeasible. Similarly, the Pipeline Alternative was also screened out due to the inability to construct new pipelines to the bases. The Truck alternative is very much the opposite in that it sacrifices total capacity (offset by adding vehicles) with its ability to provide fast delivery. While the other alternatives, namely the combined alternative, provides risk mitigation by taking the most efficient, fastest (and most likely) modes of transportation, based on stakeholder inputs, to transport biofuel throughout Hawaii. The results of this analysis leave the Truck and Combined Alternatives as the two alternatives to be considered to fulfill the requirements of the BDS.

Once the final set of feasible alternatives was generated, each alternative's performance was thoroughly analyzed by means of modeling and simulation as well as cost/benefit and schedule comparisons. The simulation of these alternatives provided data about expected system performance. The modeling and simulation results allowed the alternative architectures to be further narrowed based on performance and effectiveness criteria. The final list of possible alternatives was approved by the stakeholders for verification and validation. Once the alternative solutions were accepted, we continued to the next step of component development.

## C. MODELING AND SIMULATION

### 1. Background

Modeling and simulation provide a way to obtain insight about a system that is being designed without actually having to create or build the system in question. The primary use for simulation is to determine the effects that several alternatives will have on the overall performance of the system. After evaluating the possible alternatives, the two alternatives selected for modeling and simulation were the Truck Alternative and Combined Alternative. These alternatives were modeled using a simulation software package called ExtendSim. Simulating the alternatives in ExtendSim allowed for data to be gathered that could be used to determine whether the design goals were met. The goals that were evaluated during the simulation were whether or not 42.9 million gallons of biofuel was distributed, how long it took to distribute 42.9 million gallons, and how much excess fuel remained. The 42.9 million gallons were split up by distribution facility based on the requirements stated earlier.

When constructing the models, it was necessary to identify variables and define various assumptions. A list of variables can be seen in Table 6. The truck capacities chosen as variables were the various truck capacities that are currently available for transportation. The model also assumed an infinite supply of JP-X, biokerosene, and mixing additive input per year because the simulation was used to show how much fuel in addition to the 42.9 million gallons it was possible to distribute in a year with an unlimited supply.

<b>Variable</b>	<b>Possible Values</b>		
Truck Capacity	5000 gallons	6500 gallons	8000 gallons
Number of Trucks	5	10	15

Table 6. Simulation Variables

The possible values for the truck capacity were 5000 gallons, 6500 gallons, and 8000 gallons. The numbers of trucks were varied among three discrete values (5, 10, and 15). This gave a possibility of nine different scenarios for each alternative.

## 2. Evaluation Measures for Alternatives

The model for each alternative was divided into three sections: the mixing phase, the transportation and storage phase, and the distribution phase. These phases for the Combined Alternative model can be seen in Figures 22, 23, and 24. At the end of each section, data was collected to determine the amount of biofuel available. The model was run for a simulated time of one year in order to determine if the demand of 42.9 million gallons could be met.

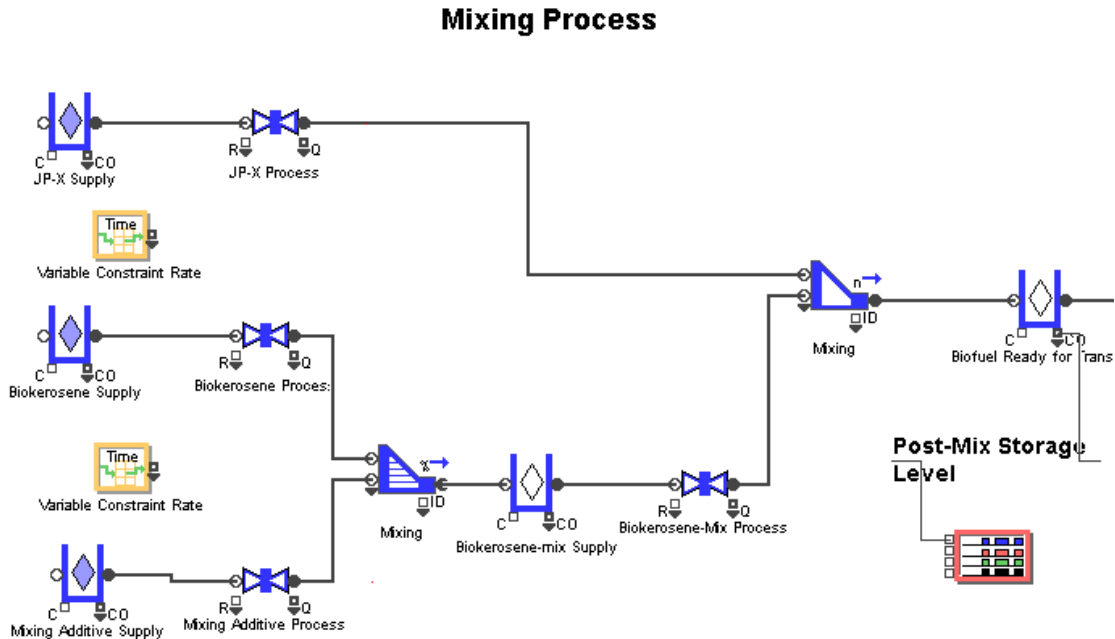

Figure 22. Combined Alternative Mixing Phase

The biokerosene and mixing additive were mixed at a 9 to 1 rate, and then combined into a 50/50 blend with the JP-X.

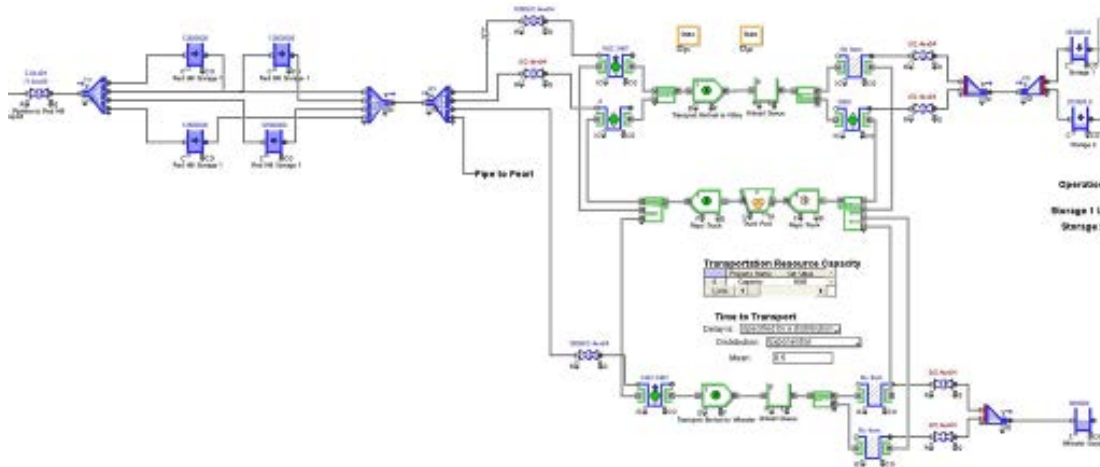

Figure 23. Combined Alternative Transportation and Storage Phase

In this phase, the biofuel is piped to Red Hill where it is stored in four tanks. From there, it is either transported by pipeline to JBPHH or by truck to MCBH and Wheeler Army Airfield.

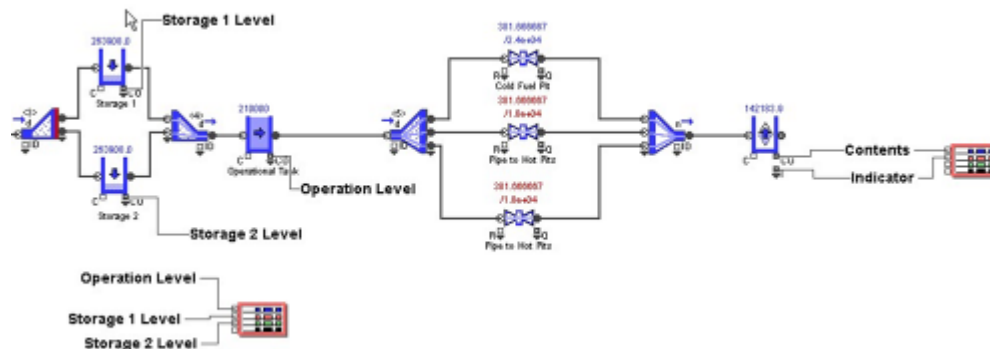

Figure 24. Combined Alternative Distribution Phase

Once the biofuel is transported to the various destinations, it is stored in a tank where it will be ready for distribution. The indicator records the time that each location meets their respective goal. Once the last location meets its goal, the time is recorded and used as a data point.



### **3. Model Description and Results**

#### ***a. Description***

The mixing phase for each alternative is identical. Each starts with three tanks that hold supplies of JP-X, biokerosene, and a mixing additive. The biokerosene and mixing additive are mixed at a 9 to 1 ratio and stored in another storage tank. This mix is then mixed with the JP-X at a 1 to 1 ratio to produce biofuel and sent to a tank where it will be ready for transportation.

The transportation phase is where the two alternatives diverge. For the Combined Alternative, the biofuel that is ready for transportation is sent through a pipeline to holding tanks in Red Hill. From there, the biofuel is either piped to JBPHH or put on a truck for transportation to Wheeler Army Airfield or MCBH. For the Truck Alternative, instead of transporting the biofuel by pipeline to the storage tanks in Red Hill, the biofuel is transported directly by trucks to JBPHH, MCBH, or Wheeler Army Airfield. Once the biofuel reaches its final destination, it is put into a storage tank to await distribution.

The distribution phase is once again common between the two alternatives. During this phase, the biofuel is stored in a tank that contains the operational biofuel that is ready to be distributed at JBPHH, MCBH, and Wheeler Army Airfield. All of the biofuel that reaches this point is considered distributed and can be taken as data.

The model is simulated multiple times for a one-year period in order to determine whether the requirements can be consistently met. Once data is gathered for one set of variables, the simulation is run multiple times for all of the other combinations of variables in order to determine the best and worst case scenarios.

#### ***b. Results***

The simulation was broken down into nine different scenarios for each alternative, which can be seen in Table 7. Each scenario was run multiple times as a way to validate the results. The averages of each scenario were used to analyze the data.

<b>Scenario Number</b>	<b>Truck Capacity (Gallons)</b>	<b>Number of Trucks</b>
1	5000	5
2	5000	10
3	5000	15
4	6500	5
5	6500	10
6	6500	15
7	8000	5
8	8000	10
9	8000	15

Table 7. Scenarios simulated for both alternatives

Table 7 shows the total number of scenarios that were simulated. The two variables were the capacity of the truck and the amount of trucks used.

After completing the simulations for both the truck alternative and combined alternative, it was determined that each could meet the demand of 42.9 million gallons per year, no matter the scenario that was used. The results from the Truck Alternative and Combined Alternative simulations can be seen in Tables 8 and 9, respectively. The simulation results facilitated a detailed analysis in terms of cost, performance, risk, and environmental impacts.

<b>Scenario Number</b>	<b>Met Goal</b>	<b>Time (Hours)</b>	<b>Excess (Gallons)</b>
1	Yes	4296.5	53,197,190
2	Yes	3808.5	57,937,499
3	Yes	3951	57,554,999
4	Yes	3159	80,343,250
5	Yes	3189	87,898,037
6	Yes	2876	89,754,812
7	Yes	2652	106,368,000
8	Yes	2376.5	118,798,156
9	Yes	2449	119,508,000

Table 8. Results for Truck Alternative

The scenario number in Table 8 corresponds to the scenario number from Table 7. The remaining columns are the average results for each scenario for the Truck Alternative.

Scenario Number	Met Goal	Time (Hours)	Excess (Gallons)
1	Yes	770	4,449,460,000
2	Yes	562	4,502,066,354
3	Yes	499	4,509,386,320
4	Yes	615	4,477,116,500
5	Yes	406	4,549,425,750
6	Yes	386	4,564,694,768
7	Yes	519	4,504,442,974
8	Yes	354	4,592,588,754
9	Yes	312	4,612,479,952

Table 9. Results for Combined Alternative

The scenario number in this Table 9 corresponds to the scenario number from Table 7. The remaining columns are the average results for each scenario for the Combined Alternative.

## **V. DETAILED ANALYSIS**

The Detailed Analysis phase is entered after the Preliminary Design phase. The inputs to this phase are the candidate alternatives that were generated during the Preliminary Design Phase. This phase is enabled by simulation models, which are used to provide the data to examine the alternatives. The outputs are simulation results that were used to determine the expected system performance and to make a recommendation. To accomplish the detailed analysis, each system alternative was examined from the performance, cost, risk, and environmental perspectives.

### **A. PERFORMANCE ANALYSIS**

To better evaluate the differences between the two candidate system configurations, the Biofuels team conducted an analysis considering only the performance aspects of the system. The reason for this method of analysis was to independently assess the capability of the system. The two metrics analyzed were 1) the time to meet the goal of 42.9 million gallons distributed (the Time metric) and 2) the amount of excess fuel delivered to the customers over a one-year period (the Excess metric). The Time metric shows how many hours the distribution system will be dedicated to delivering the required goal of 42.9 million gallons of biofuel to the customers. The Excess metric assumes that the system operates around the clock for an entire year. These two metrics enabled the team to get an idea of how quickly the system could distribute the required fuel and what the overall capacity of the system would be in case a surge operation was ever needed.

To accomplish the performance analysis, a two-factor design of experiment (DOE) was created in Minitab. The ExtendSim model was run five times for each system configuration and average responses were recorded and input into Minitab. This data is found in the Modeling and Simulation section of the report. Interaction plots of these metrics were then generated via Minitab's software suite to aide in the performance analysis.

## 1. Truck Alternative Analysis

To analyze the Truck Alternative, the two system variables (truck capacity and number of trucks) were simulated, the results of the five runs averaged, and graphed via Minitab. This process resulted in the two figures below. Figure 25 plots time to deliver the goal of 42.9 million gallons to the customer against the number of trucks used and Figure 26 plots the amount of excess fuel delivered (in millions of gallons) against the number of trucks used. To achieve the best performance, the time to deliver fuel should be minimized and the amount of excess fuel delivered maximized. For both figures, the difference capacities of the trucks are indicated on the legends to the right of the graph. The solid line represents 5000-gallon capacity trucks, the large dashed line represents 6500-gallon capacity trucks, and the small dashed line represents 8000-gallon capacity trucks.

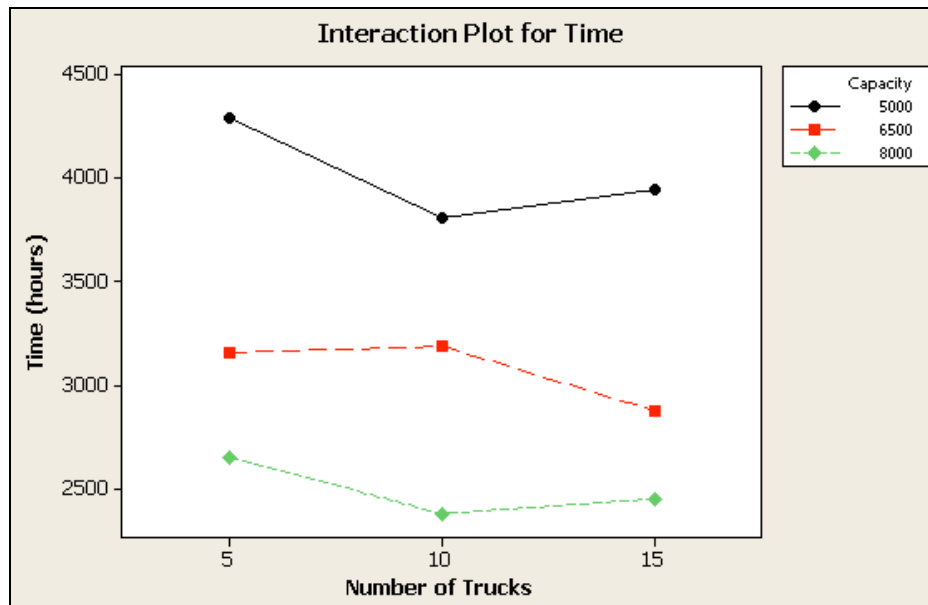

Figure 25. Interaction plot of Time (hours) for the Truck Alternative

It can be seen graphically that there is a marked decrease in time (and therefore an increase in performance) in the 5000- and 8000-gallon capacity trucks as the number of trucks moves from five to ten, and an increase in time (a decrease in performance) between 10 and 15 trucks. The plateau found in the increase from 10 to 15 trucks is due

to the simulated trucks overloading the loading and unloading stations. This behavior created congestion at the queues for each activity within the model.

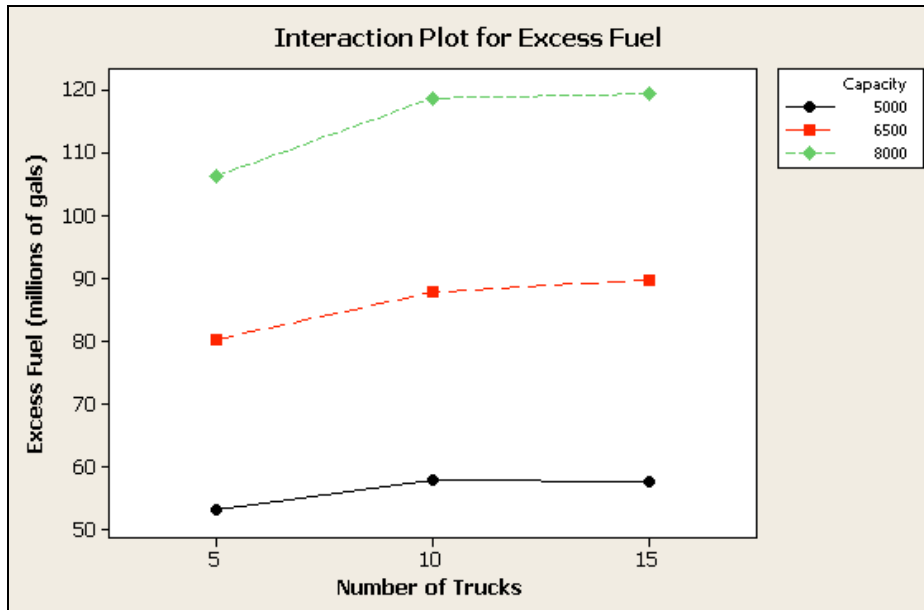

Figure 26. Interaction plot of Excess (millions of gallons) for the Truck Alternative

As was expected, the increased performance of varying the capacity of the trucks resulted in an approximately linear increase in the amount of excess fuel delivered; as capacity increased, the amount of fuel delivered increased.

While each configuration met the target goal of 42.9 million gallons of fuel delivered, the team looked at surge performance to see if this alternative would be capable of handling an increased demand. To estimate the maximum required surge, the team looked at the total fuel consumption of DoD assets in Hawaii (128 million gallons per year) and adjusted the number based on an estimated fuel consumption increase of 1.5% per year. The fuel consumption increase estimate was provided by PACOM (personal communication). Due to the requirement to field the system by 2020, the requirement was calculated to be 142 million gallons per year. The team then assessed the BDSs ability to distribute 100% of the fuel requirement per year, rather than 25%. The results are charted in Figure 27. Each alternative is plotted to show the amount of

excess fuel delivered. The dashed line represents the surge goal of 142 million gallons per year. Figure 27 shows that no truck-only configuration alternative meets the surge goal.

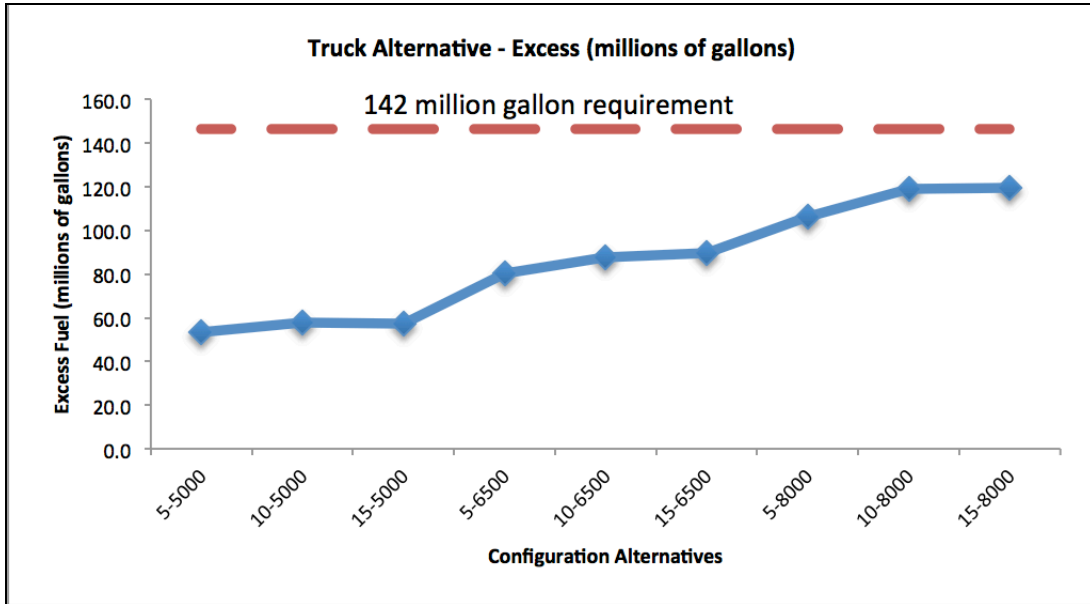

Figure 27. Excess Fuel (millions of gallons) versus 100% of consumed fuel

To further investigate the performance of the Truck Alternative, ratios of the metrics were calculated. These metric ratios were gallons/hour, gallons/trucks, and gallons/trucks/hour and are plotted below. The vertical axis depicts the respective ratio and the horizontal axis depicts the various configuration alternatives. These are labeled in shorthand for ease of graphing by the number of trucks and their capacities. For example, the configuration alternative labeled “10–5000” is the configuration utilizing ten 5000-gallon capacity trucks.

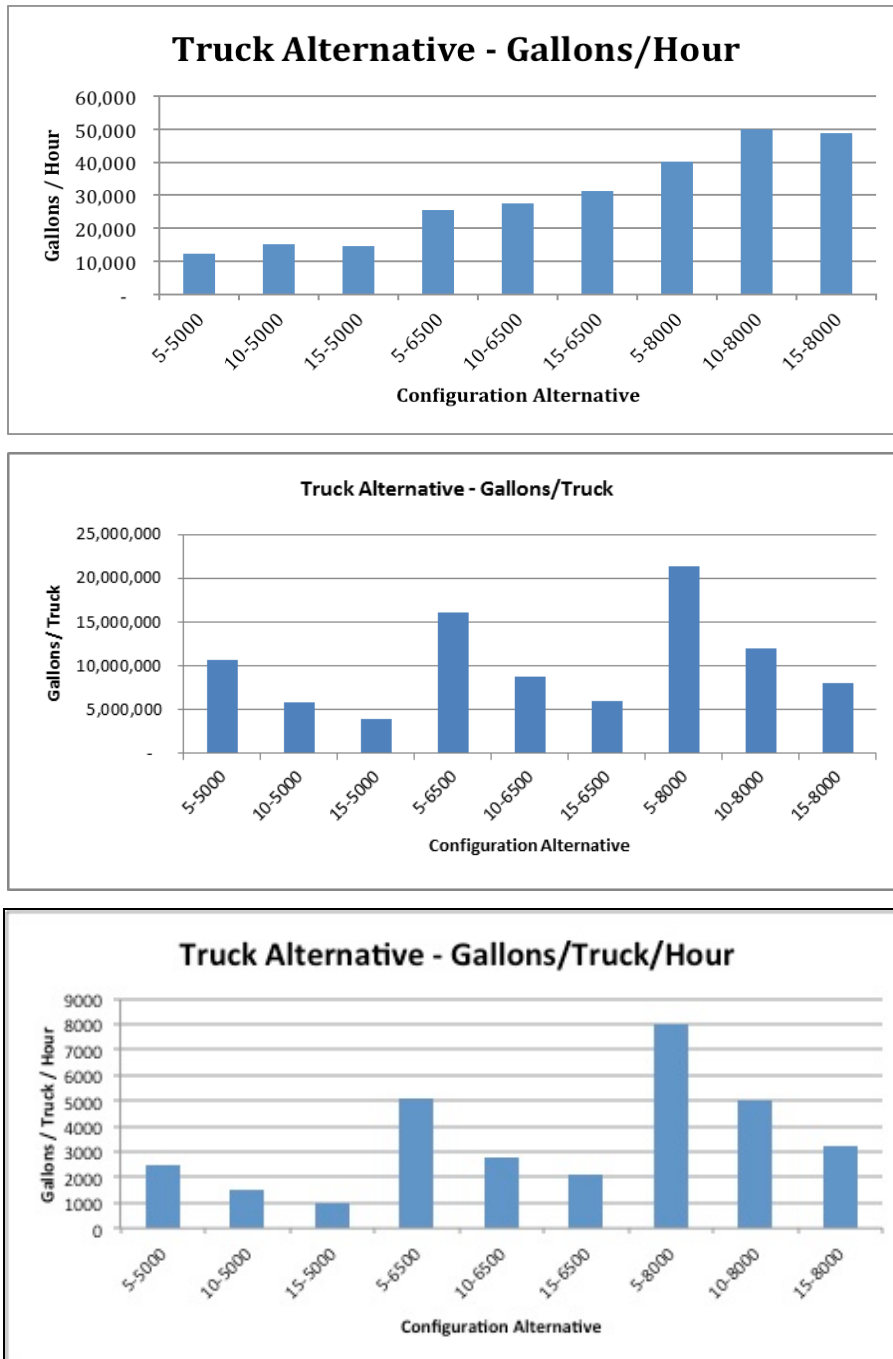

Figure 28. Metric Ratios of the Truck Alternative

Figure 28 shows that the five truck configurations outperform the others. Based on these ratios, the most efficient configuration is any alternative consisting of five trucks.



Further analysis of the three configurations utilizing five trucks was conducted by plotting the performance of each metric against each other. This yielded Figure 29, which graphs the amount of excess fuel (gallons) against the time to deliver the target goal for the five truck alternatives. Here, the best performance is located in the upper right corner of the figure. Using this figure and all prior analysis, the Biofuels team determined that based on performance, the configuration utilizing five 8000-gallon capacity trucks were the ideal configuration within the Truck Alternative.

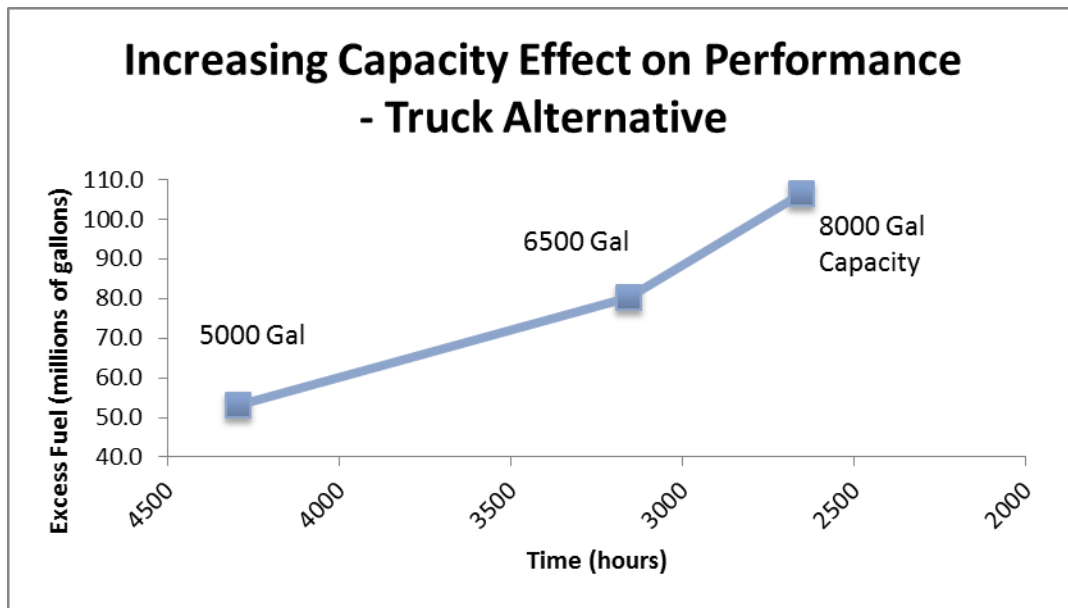

Figure 29. Increasing Capacity Effect on Performance (Five Truck Alternative)

## 2. Combined Alternative Analysis

A similar analysis was conducted on the Combined Alternative. The resulting trends remained the same; a large increase in performance was noted as the number of trucks increased from five to ten and a smaller increase noted from 10 to 15. The plots below show the performance of the Combined Alternative. As with the previous graphs, the number of trucks is plotted along the horizontal axis and the time to deliver fuel in hours and excess fuel delivered (in millions of gallons) are along the vertical axis. Again, the solid line represents 5000-gallon capacity trucks, the large dashed line the 6500-gallon trucks, and the small dashed line the 8000-gallon capacity trucks.

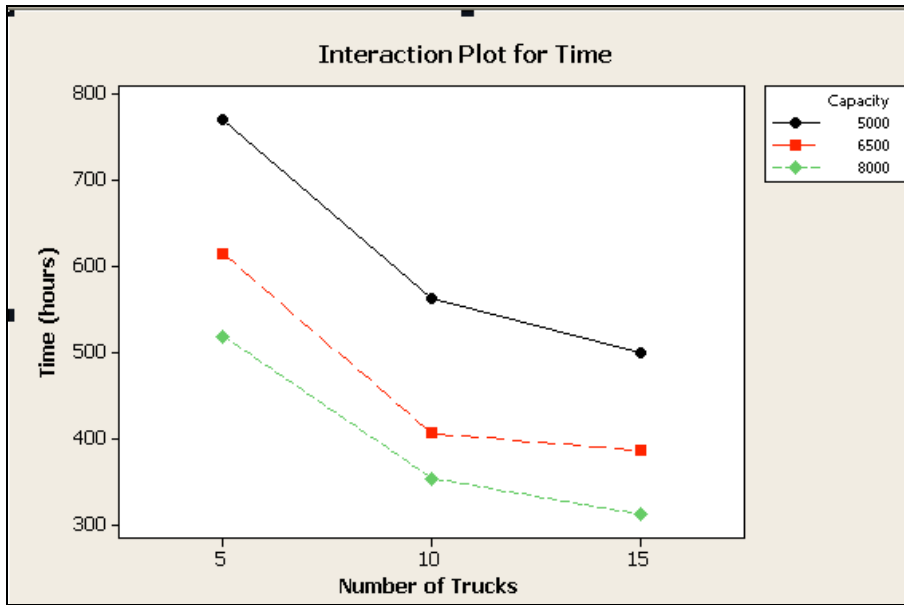

Figure 30. Interaction plot of Time (hours) for the Combined Alternative

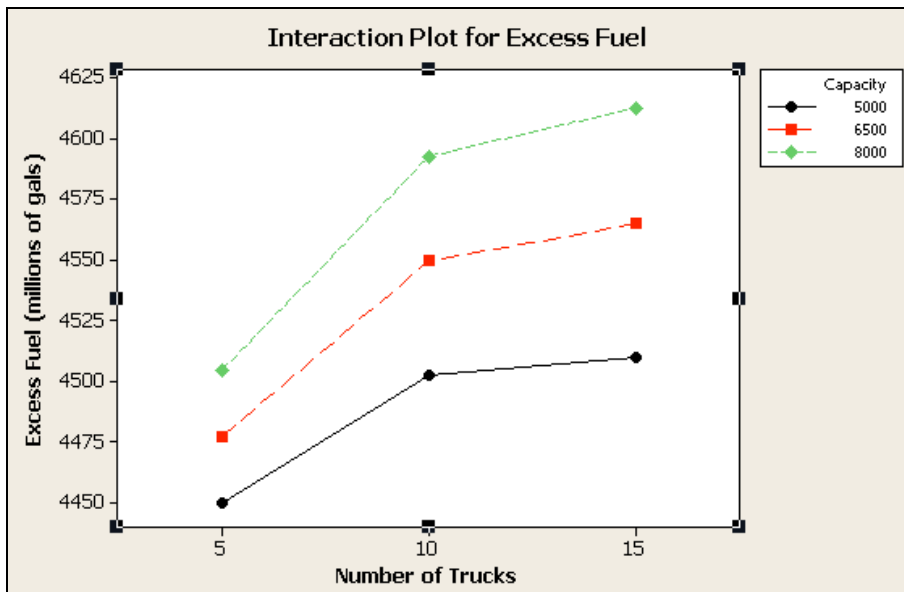

Figure 31. Interaction plot of Excess (millions of gallons) for the Combined Alternative

The major difference between the Truck and Combined alternatives was the scale of performance. The best performing configuration of the Truck Alternative met the goal of 42.9 million gallons in approximately 2376 hours with an excess capacity of roughly

119 million gallons. Conversely, the *lowest* performing configuration of the Combined Alternative met the goal in 312 hours with an excess capacity of almost 4.6 billion gallons of fuel. Table 10 shows the average performance of the Combined Alternative as compared with the Truck Alternative. The shaded cells denote the recommended configuration, in terms of performance, of the Truck Alternative.

Variables		Truck Alternative		Combined Alternative	
Capacity	Number of Trucks	Time (hours)	Excess (gallons)	Time (hours)	Excess (gallons)
5000	5	4296.5	53,197,190	770	4,449,460,000
5000	10	3808.5	57,937,499	562	4,502,066,354
5000	15	3951	57,554,999	499	4,509,386,320
6500	5	3159	80,343,250	615	4,477,116,500
6500	10	3189	87,898,037	406	4,549,425,750
6500	15	2876	89,754,812	386	4,564,694,768
8000	5	2652	106,368,000	519	4,504,442,974
8000	10	2376.5	118,798,156	354	4,592,588,754
8000	15	2449	119,508,000	312	4,612,479,952

Table 10. Average Simulation Results of Both Alternatives

As with the Truck Alternative, the results were compared to the 142 million gallons per year surge requirement. These calculations show that the Combined Alternative can easily handle 100% of any surge in biofuel production. Additionally, ratios were again used to analyze the performance of the Combined Alternative and the results are found in Figure 32. The vertical axis depicts the respective ratio and the horizontal axis depicts the various configuration alternatives. These are labeled in shorthand for ease of graphing by the number of trucks and their capacities, as before.

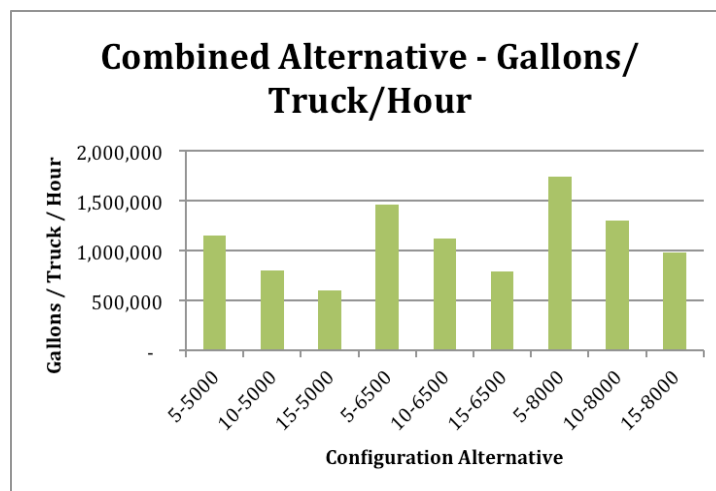
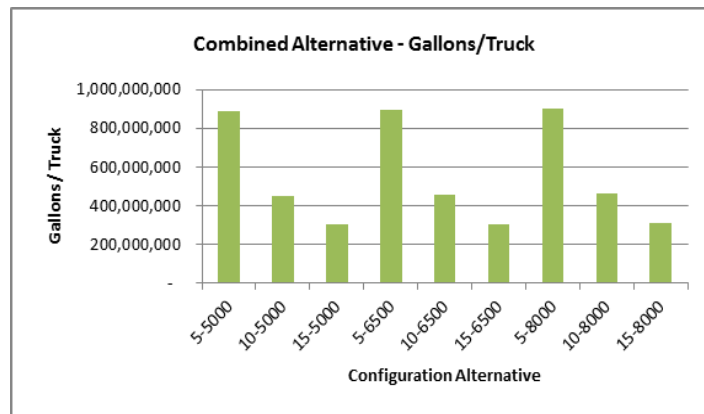
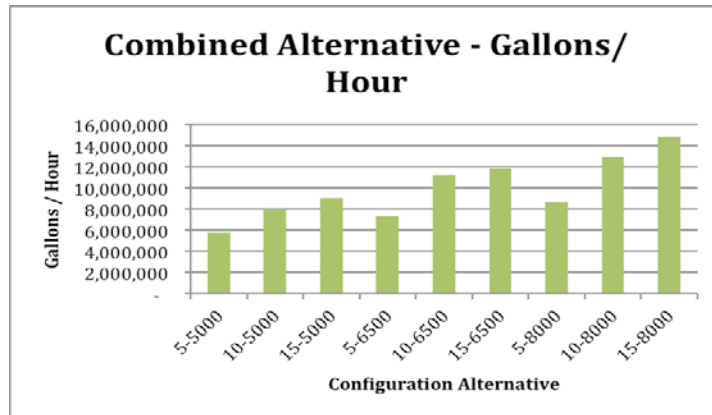

Figure 32. Metric Ratios of the Combined Alternative

It can be seen from the Figure 32 that the five-truck alternatives consistently outperform the other configurations. Based on these ratios, we again found that the most efficient configuration is any that involved five trucks.

To further analyze the various configurations within the Combined Alternative, the performance of the three highest performing alternatives were plotted and the result is in Figure 33. The vertical axis indicates excess fuel in millions of gallons and the horizontal axis indicates time. As before, the ideal performance is located in the upper right side of the figure.

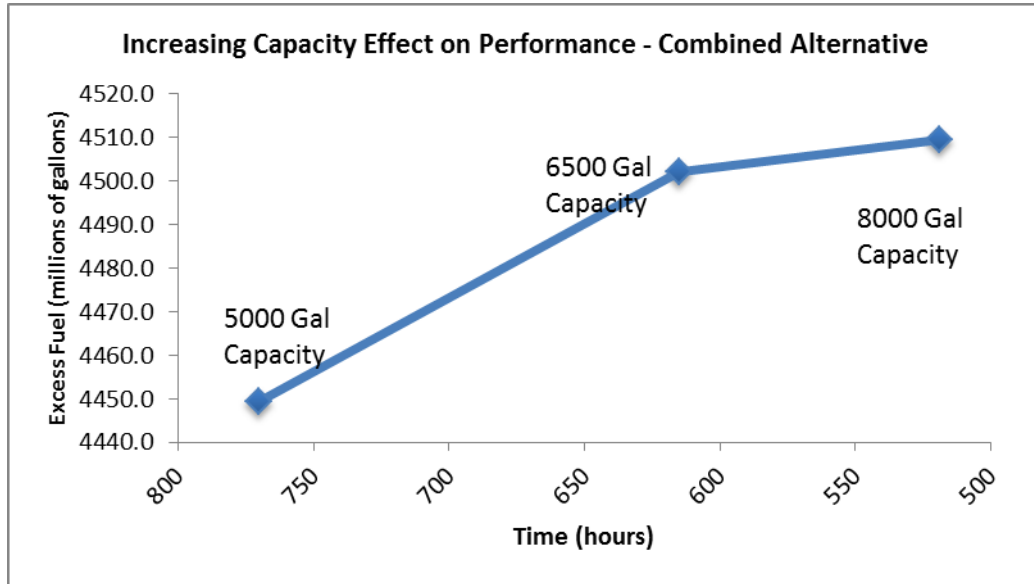

Figure 33. Increasing Capacity Effect on Performance (Five Truck Combined Alternative)

It can be seen that there is a performance plateau when the configuration moved from 6500 to 8000-gallon capacity trucks. Therefore, the team recommended that the 6500-gallon capacity configuration provided the ideal performance.

Based on this analysis, the Biofuels team determined that the optimal configuration within the Combined Alternative utilizes five 6500-gallon capacity trucks. In this alternative the pipeline will only be utilized for 615 hours per year to transport the current requirement of 42.9 million gallons of biofuel. This leaves the remaining time throughout the year to transport petroleum-based fuels and perform maintenance on the pipelines. In addition, the five trucks will only be required to operate for an average of 615 hours per year to meet the current biofuel-delivery requirements. Assuming that a typical man-year is 2,000 hours, based on working five eight-hour days a year, and that

the trucks would only be used on one shift, then the trucks will only be utilized at about 30% of their combined capacity. This will allow the trucks to easily contribute to any surge requirements.

### **3. Performance Analysis Summary**

The results of the performance analysis show that the Combined Alternative outperforms the Truck Alternative in terms of time to deliver the required amount of biofuel and excess, or surge, capacity. Further analysis showed that the use of five 6500-gallon capacity trucks provided the system with the ideal configuration.

### **B. COST ANALYSIS**

The team investigated the cost associated with implementing each alternative BDS. This section of the report will focus on the truck and combined alternatives that were modeled and simulated by the team. Analysis focused on the infrastructure including pipelines, storage tanks, mixing tanks, trucks, and tanker trailers. The team focused on the cost difference between alternatives. Therefore, labor and other overhead costs are not provided as line items in the analysis, as they were included in the associated cost metrics for each delivery method. Furthermore, the total ownership cost of the holding tanks was not considered because although the tank may initially be funded through a biofuel initiative, it may not solely service the BDS, and as such the costs are incurred under general DoD infrastructure. For this reason we attempted to determine the initial installation cost of a fuel tank only, and not the total life cycle cost of the fuel tank. Similarly, initial costs for trucks are presented, but total ownership costs was not considered because they may not solely service the BDS. Consistent with the model, the costs are broken down into three phases: mixing, transporting, and distribution. Additional supporting data tables are presented in Appendix D.

#### **1. Mixing Phase**

The mixing phase for each alternative is identical. A total of five storage tanks are used. Three tanks are used to hold the supplies of JP-X, Biokerosene, and the Mixing Additive. One tank is used mid-process for storage of the 50/50 mixture of the

Biokerosene and the Mixing Additive, while the last tank holds the final mixture that is ready for transporting. A schematic is provided in Figure 34.

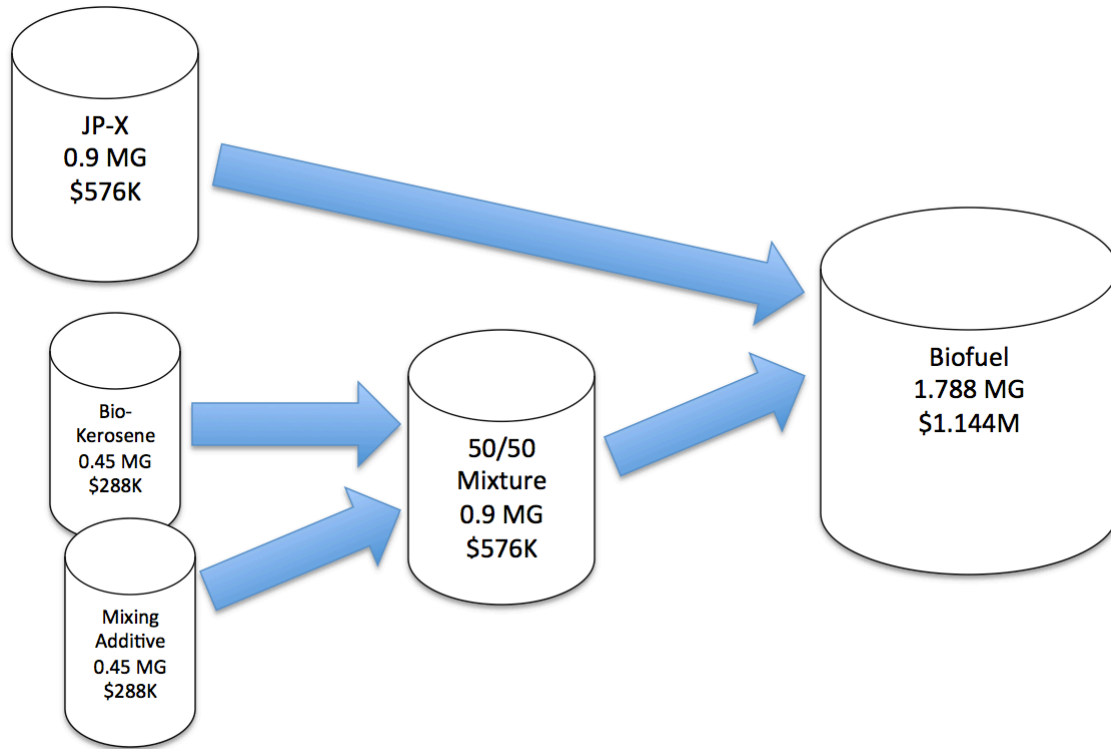

Figure 34. Mixing Phase Tank Layout, Capacities, and Costs

A total of 42.9 MGY of biofuel, or 3.575 MG per month throughput is required. Having a capacity to store a half-month supply, 1.788 MG, of fuel at the mixing site was used for costing because fuel will be continuously transferred to the bases as part of the transportation phase. The cost of constructing bulk storage tanks is approximately \$0.64 to \$1.84 per gallon estimated from government awarded contracts in the past (PAAP USSEC 2008) (MEB 2013). The cost for each tank was calculated utilizing the less expensive cost estimate per gallon due to the large size of the storage tank. The capacity and costs are shown in Figure 34. The total price for construction and installation of all five tanks is estimated to cost \$2.87M.

## 2. Transportation Phase

An independent trucking company was interviewed to determine the contracted cost for moving the tanker trailers. Theodor Kistner, owner of Specialized Trucking, stated that, “the average cost is \$2.50 per mile, which includes fuel, maintenance of the truck, drivers pay, maintenance of the trailer and other overhead for the carrier providing the service” (personal communication). The approximate distance from the refinery to the eastern most military installation (MCBH) is 64 miles round trip. The costs per trip and total costs per year are presented in Figure 35.

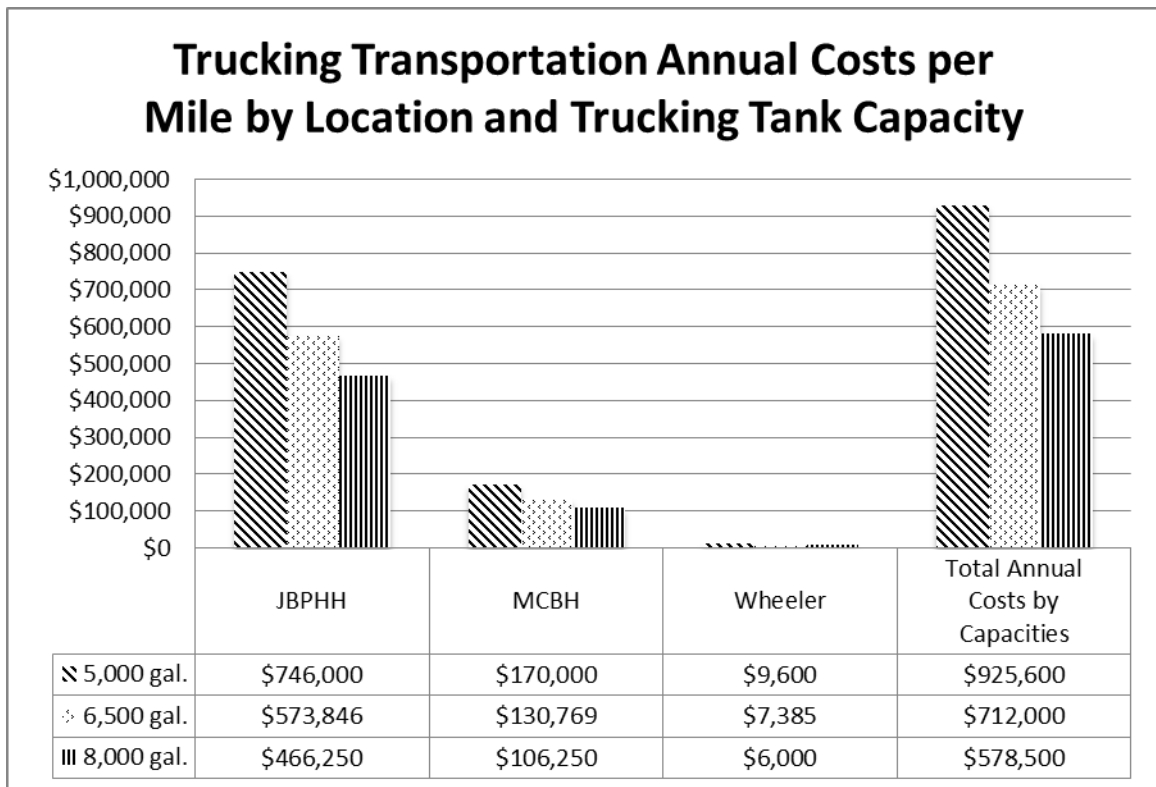

Figure 35. Trucking Transportation Costs per Mile by Location and Trucking Tank Capacity

An estimated cost was achieved using the given cost per truck-mile, the known distance between locations, and the required quantity of fuel needing to be delivered annually to each site. The team assumes a linear increase for calculating the cost per truck-mile, but as mentioned above, having a greater than 50 miles round trip (64 for



MCBH) will result in a less than linear cost. Increasing the frequency of shipping evolutions will also reduce costs. Figure 35 shows that by increasing the tanker trailers capacity from 5,000 gallons to 8,000 gallons the trucking transportation cost decrease by \$347,100 or 37.5%.

With the cost per trip estimated, the team took this data and compared it to the latest DLA data report (Defense Logistics Agency Energy, 2012). Table 11, originally presented in the DLA Fact Book, was modified to include the additional metrics: gallons transported, cost per gallon, and gallons per shipment (Defense Logistics Agency Energy, 2012, 49).

	Truck CONUS	Truck OCONUS	Pipeline CONUS	Pipeline OCONUS
Shipments	18,973	8,033	2,090	1,088
Cost (millions)	\$48.00	\$27.60	\$80.00	Not Provided
Barrels (millions)	12.4	2	41.9	9.3
Gallons (millions)	390.6	63	1319.85	292.95
Cost per gallon	\$0.12	\$0.44	\$0.06	Not Provided
Gallons/Shipment	20,587.15	7,842.65	631,507.18	269,255.51

Table 11. Frequency, Cost, Volume Data (after DLA, 2011)

Costs associated with OCONUS pipeline shipments are funded under an international agreement and were excluded in the DLA Fact Book to avoid duplicate information.

From Table 11, the cost per gallon of fuel delivered averaged \$0.12 for contiguous United States (CONUS) and \$0.44 for outside [the] contiguous United States (OCONUS). The average delivered distance was not included in the report nor was data for Hawaii operations, which are assumed to be similar in cost to the CONUS average. A delivery of 5,000 gallons of fuel costs DLA \$600. Using the previous commercial cost per truck-mile analysis, the 64 mile round trip haul to MCBH costs \$170. Subtracting this value from the DLA cost provides insight into the other operating costs incurred by DLA. It is estimated that \$430 dollars, out of the total of \$600, covers the overhead, on and off

load support, non-truck or trailer related infrastructure maintenance, and new equipment procurements for transporting fuel. Figure 36 presents the cost using the DLA averaged \$0.12 per gallon to deliver fuel by trucking.

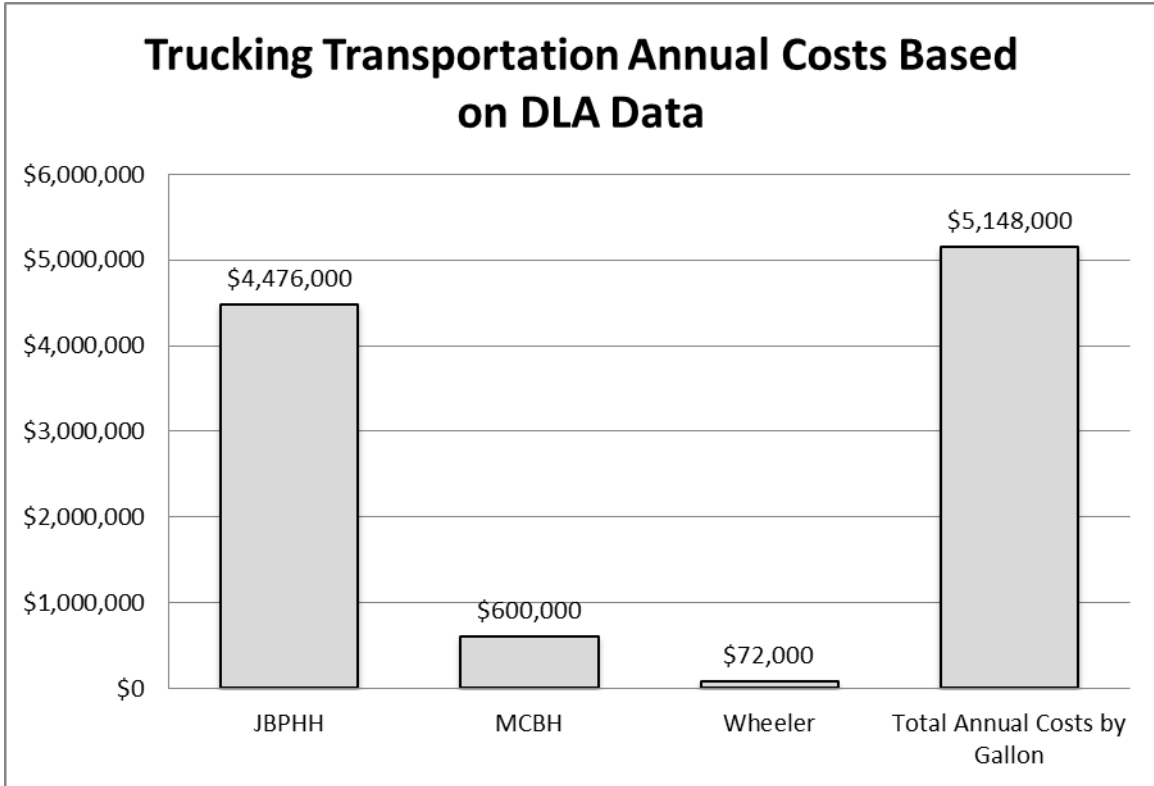

Figure 36. Trucking Transportation Annual Cost Based on DLA Data

The estimated total cost to provide fuel to all three locations was \$5.148M. This volumetric cost parallels the findings for costs based on distance. As volumetric fuel delivery increases, the amount of transportation deliveries and consequently miles driven must also increase.

Another factor worth considering is the cost to purchase a truck and trailer in order to transport the biofuel. The team analyzed the cost of purchasing five, ten, or fifteen trucks as a separate alternative independent of which distribution alternative is chosen as a whole. The approximate costs for purchase of a new Class 8 Heavy Duty tractor-trailer is \$110,000. (U.S. Department of Energy 2009) The approximate cost for

5,000-gallon capacity trailer is \$45,000; the approximate cost for 6,500-gallon capacity trailer is \$53,000; the approximate cost for 8,000-gallon capacity trailer is \$60,000. (Traversi 2013) These three fleet alternatives (five, ten, or fifteen trucks) would be a significant investment in this system and these costs are plotted in Figure 37.

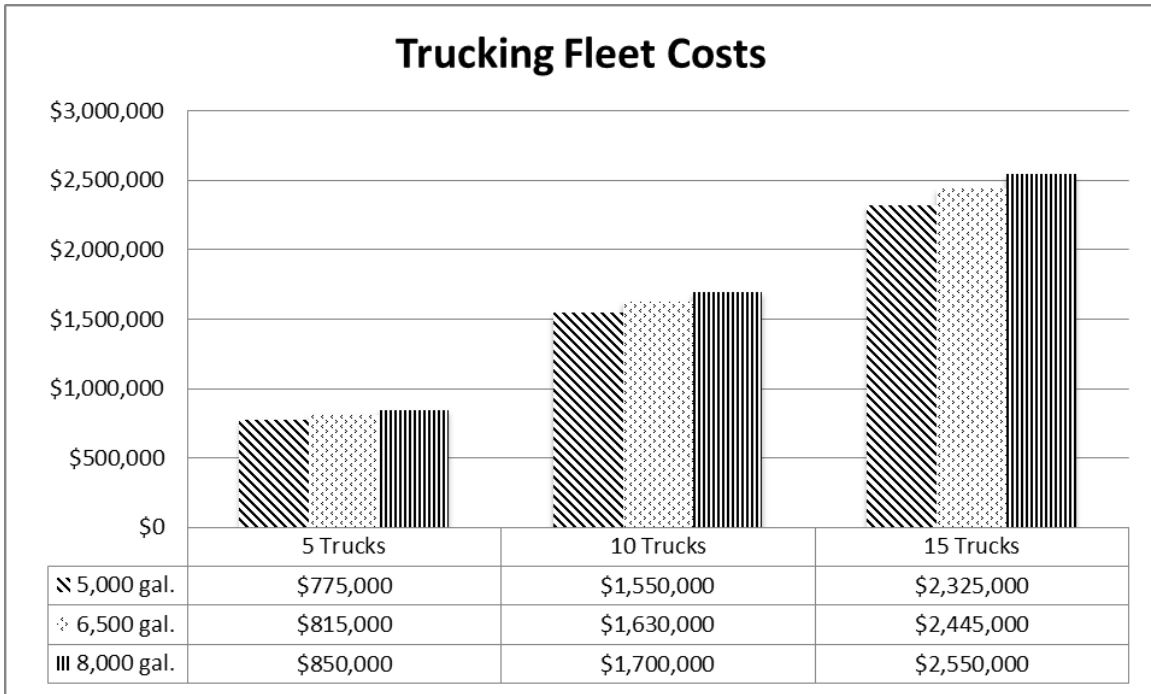

Figure 37. Trucking Fleet Costs by Capacity

As shown in Figure 35, the option to increase trailer capacity from 5,000 gallons to 8,000 gallons reduces transportation cost by \$347,100 or 37.5%. All modeled simulations found that the transportation of 42.9MGY requirement could be met with a fleet of five trucks. Therefore, the team recommends procuring five trucks and five 8,000 gallon capacity trailers. This solution will optimize cost and performance.

### 3. Transportation of fuel using the combined alternative

This alternative exploits the existing infrastructure of pipes to deliver fuel with significantly less trucking. As shown in Figure 38, Fuel from the refinery (1) will travel approximately 18 miles through existing pipelines to the Red Hill Fuel Storage Facility

(2). From Red Hill, the fuel is moved using existing pipelines to JBPBH while fuel for MCBH and Wheeler must be trucked.

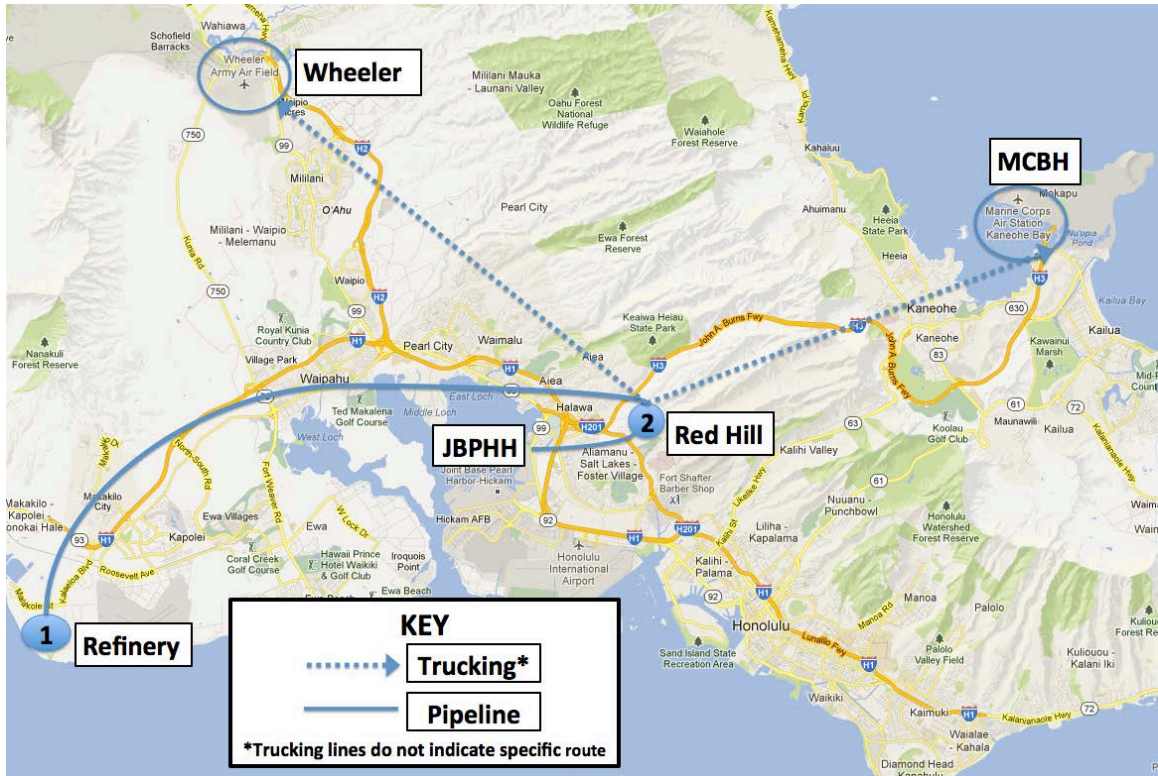

Figure 38. Transportation Logistics between Military Aviation Assets in Hawaii

The approximate cost to pipe fuel is \$0.06 per gallon according to the data provided by DLA in Table 11. This value is for operating existing pipelines and does not include the cost to build new pipelines. All fuel initially goes to Red Hill for storage and distribution. The costs per trip and total costs per year are presented in Figure 39.

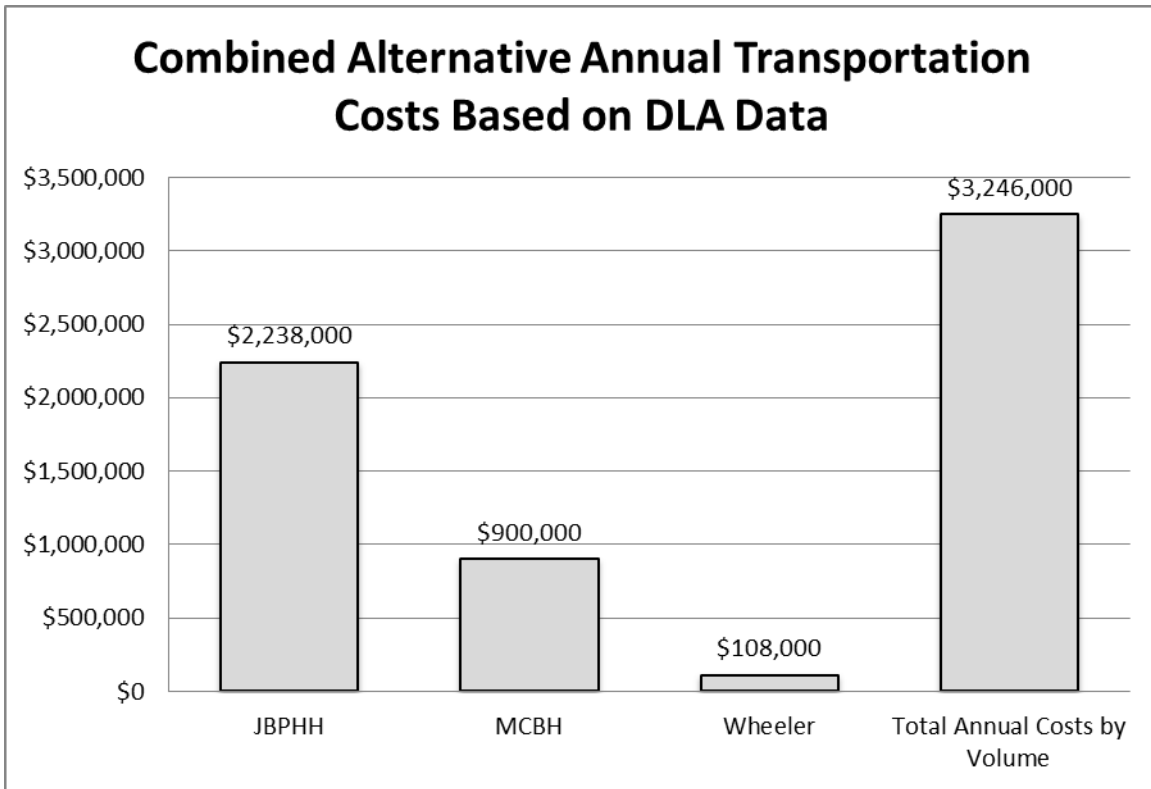

Figure 39. Combined Alternative Annual Transportation Costs Based on DLA Data

The assumptions made for the trucking portion of the combined cost analysis are the same used for the trucking only analysis. The team chose to use the volumetric cost of \$0.12 per gallon to be consistent with the pipeline’s volumetric cost analysis. Costs associated with procuring new trucks and tanker trailers were not included in data presented in Figure 39 but was used to evaluate the optimal number of trucks necessary to meet the fuel delivery objectives. The estimated total cost to provide fuel to all three locations was \$3.246M. Volumetric figures are reasonable for pipeline transfers, but it is not clear how or if DLA specifically factors in the distance the fuel has to travel.

#### 4. Distribution Phase

The biofuel is distributed into the consumers’ tanks once it is transported. The contributing cost factors for storage of the fuel at each location is independent of the transportation method. Thus, the costs of the distribution phase are fixed being common for both alternatives. One custom tank configuration is required at each of the three sites

Wheeler, MCBH, and JBPHH. The biofuel tanks would need to be installed to hold the operational biofuel required for the throughput of fuel at each site. The biofuel throughput volume at Wheeler is 0.6 MGY or 50,000 gallons a month; which is about half the average motor fuel a convenience store sells in the United States (NACS 2013). The mean cost of adding biofuel infrastructure and holding tanks to a site comparable to Wheeler would be \$71,735 (NREL 2013). The cost of constructing bulk storage tanks is approximately \$0.64 to \$1.84 per gallon estimated from government awarded contracts in the past (PAAP USSEC 2008) (MEB 2013). The biofuel throughput volume at MCBH is 5 MGY or approximately 416,666 gallons per month. The cost of a tank to maintain a half-month supply of 208,333 gallons would cost approximately \$133,333 utilizing the less expensive cost estimate per gallon due to the large size of the storage tank. The biofuel throughput volume at JBPHH is 37.3 MGY or approximately 3,108,333 gallons a month. The cost of a tank to maintain a half-month supply of 1,554,166 gallons would cost approximately \$994,666 utilizing the less expensive cost estimate per gallon due to the large size of the storage tank.

## **5. Cost Summary**

The cost analysis performed determined fixed upfront costs for both the mixing phase and distribution phases. The transportation phase cost analysis involved recurring cost options for detailed evaluation. Two alternatives were investigated for the transportation phase including trucking transportation versus combined pipeline and trucking transportation. The analysis was itemized to include location dependent cost figures on an annual basis and the effects of using three different tanker truck sizes. The cost analysis determined that for the transportation phase the combined alternative was the most cost effective option. Total annual transportation costs, not including initial capital costs or factoring in life cycle costs, for the combined alternative were \$3.246M, or 37% less than the trucking only option costing \$5.148M. Initial capital investments total \$4.95M, which is comprised of: five mixing tanks totaling \$2.87M, five trucks and five 8,000 gallon capacity tank trailers totaling \$875K, and one holding tank at each of the three bases totaling \$1.2M.

### **C. RISK ANALYSIS**

The goals of this risk analysis were threefold. Initially, we needed to ensure that undesirable events that have the potential to affect the ability of each BDS architecture to meet the key stakeholder's performance requirements were identified. Once identified, each of these events or risks was analyzed to determine the likelihood of it occurring and the consequence if it does occur. Finally, the resulting risks for each alternative were compared.

The methodology used to identify the undesirable events was derived from the National Aeronautics and Space Administration (NASA) Probabilistic Risk Assessment (PRA) process. The PRA process has been described as, "A collection of methods applied through scenario development to map complex reality into a set of logical relationships so that they can be efficiently analyzed through computer-based algorithms based on carefully formulated input" (Rhoades 2012). The NASA guidance, *The Probabilistic Risk Assessment Procedures Guide for NASA Managers and Practitioners*, recommends using Master Logic Diagram (MLD) to help to identify initiating events (Stamatelos et al. 2011, 3–11). A MLD is a hierarchical, top-down display that shows the end state of concern at the top and is decomposed through the system functions and continues downward with increasing level of detail until you reach the potential initiating events at the bottom of the logic diagram. An example of a MLD is illustrated in Figure 39.

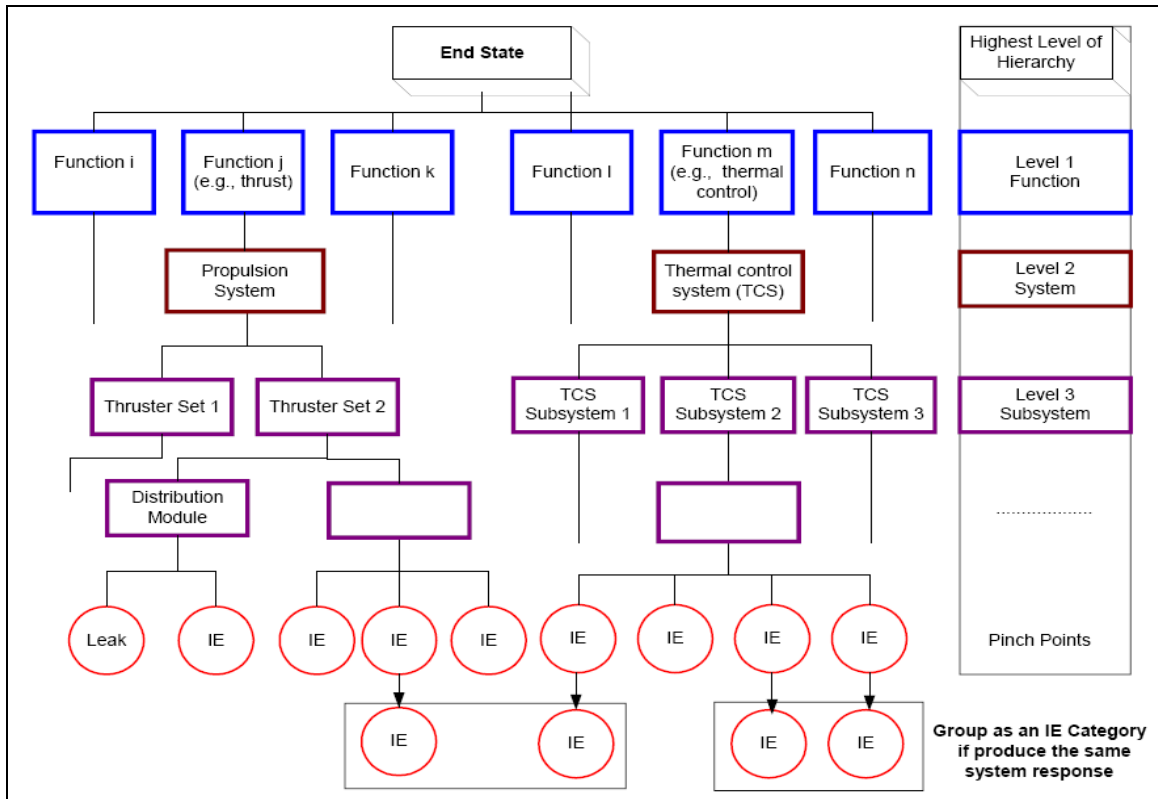

Figure 40. Master Logic Diagram Example (From Stamatelos, et al. 2001, 3–12)

Based on feedback from stakeholders, there were two end states of concern that required analysis. The first was a failure of the BDS to provide adequate biofuel to the end users. Where “adequate biofuel” is defined as fuel of sufficient quantity and quality to meet the end users needs. The second end state of concern was a failure of the BDS to prevent a biofuel spill or hazard.

These end states of concern were analyzed using a MLD to help to identify the all of the possible initiating events that could lead up to an end state of concern for the truck alternative and the combined alternative system architectures. All four of the MLDs that were developed (shown in Figures 41, 42, 43 and 44) by stating the end state of concern at the top of the diagram and then flowing down through the system top level functions. The four top level system functions (level 1), mixing, transportation, storage and distribution, were then analyzed to determine the sub functions (level 2) that could lead to



a failure. The sub functions were then analyzed to determine the events (level 3) that could cause them. These resulting initiating events are the risks that could lead to the end states of concern.

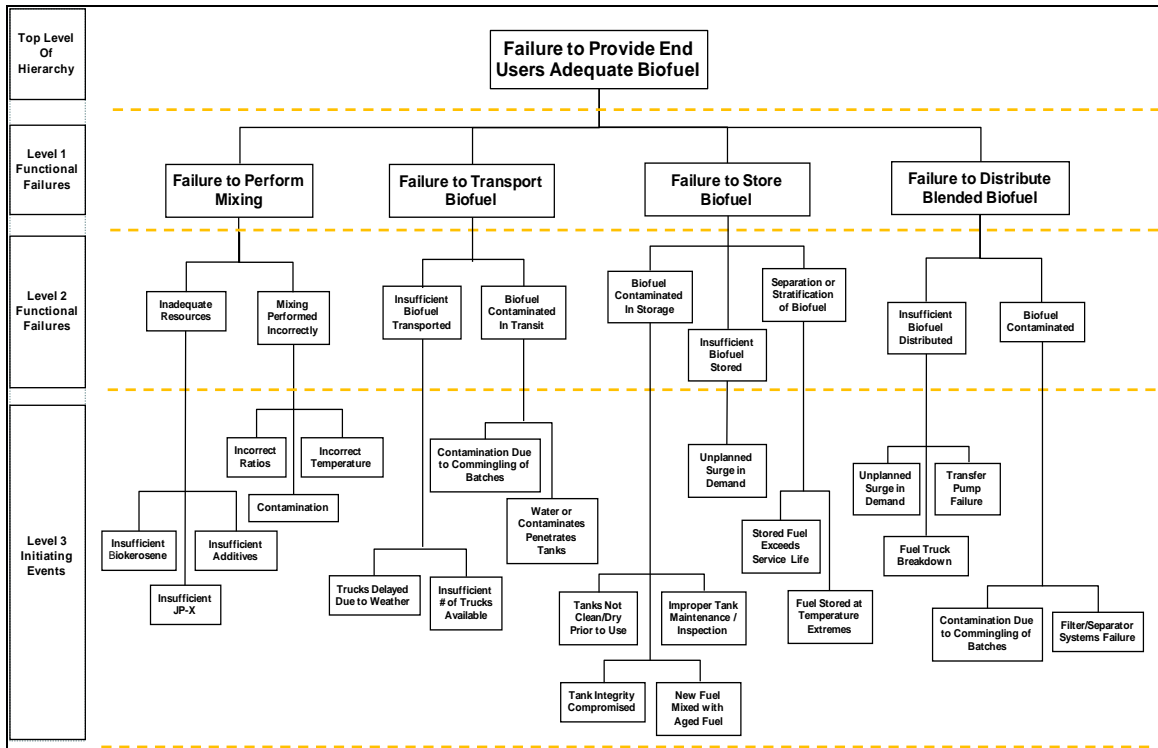

Figure 41. Master Logic Diagram - Truck Option Failure to Provide Adequate Biofuel

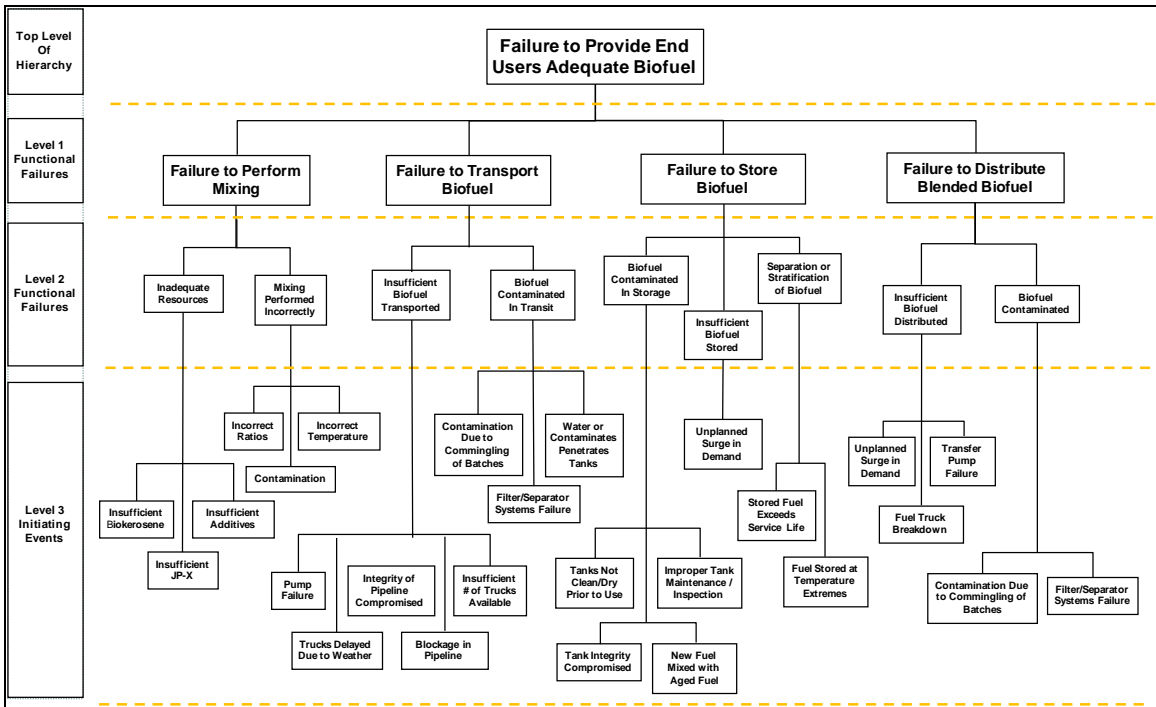

Figure 42. Master Logic Diagram - Combined Option / Failure to Provide Adequate Biofuel

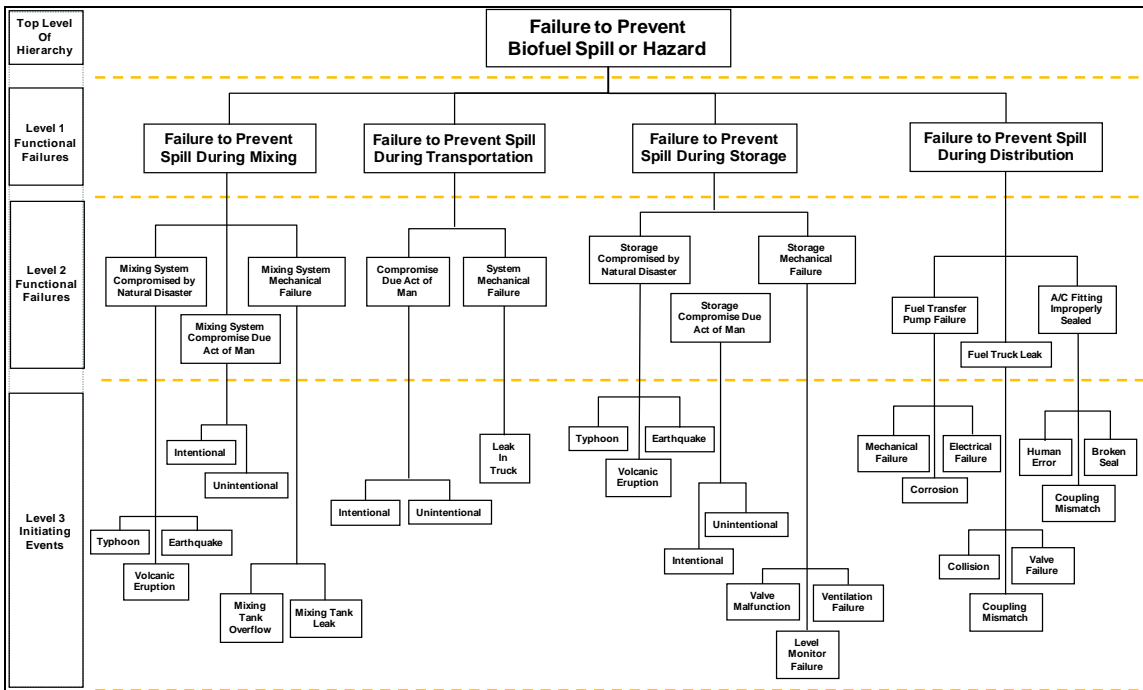

Figure 43. Master Logic Diagram - Truck Option / Failure to Prevent Biofuel Spill

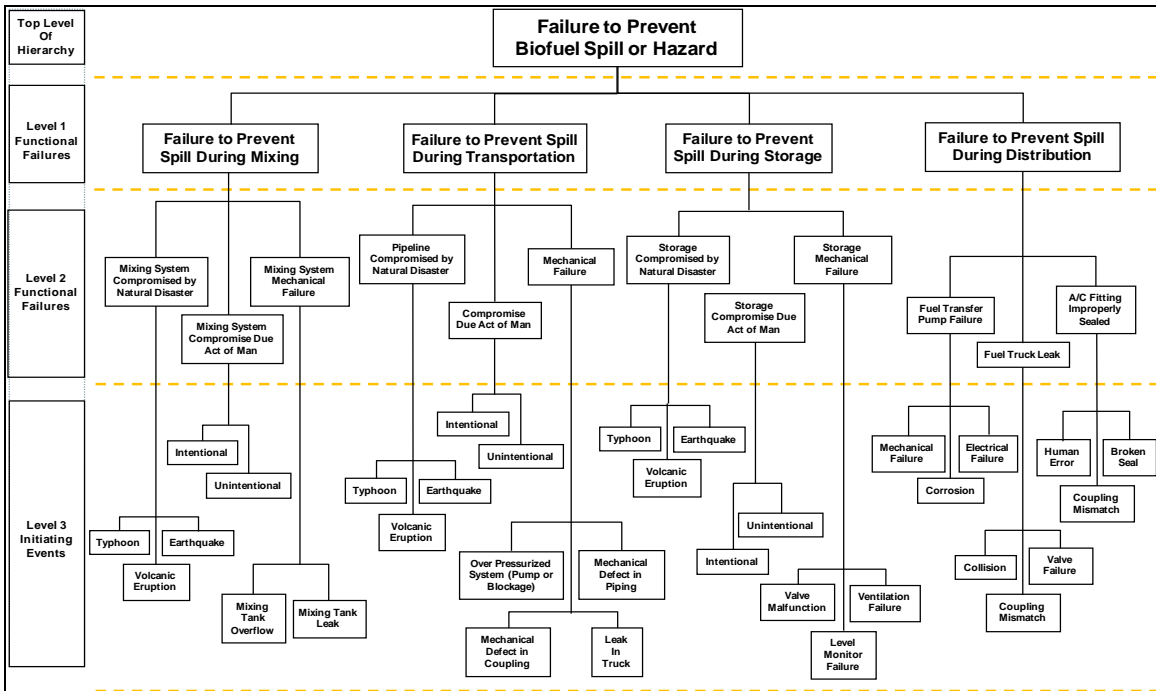

Figure 44. Master Logic Diagram - Combined Option / Failure to Prevent Biofuel Spill

Having identified the risks associated with the ability of the different system alternatives to address the end states of concern, the next step was to assess the risks based on the likelihood they are to occur and the impact if they were to occur. A qualitative assessment was made by researching historical data on the likelihood and consequence for each risk (Det Norske Veritas 2010) (National Weather Service Forecast Office 2006). The criteria shown in Figure 45 and Figure 46 were then applied and a risk matrix was generated for each of the risks.

Likelihood	Level	Likelihood	Probability of Occurrence
	1	Not Likely	~10%
	2	Low Likelihood	~20%
	3	Likely	~50%
	4	Highly Likely	~70%
	5	Near Certainty	~90%

Figure 45. Risk Likelihood Criteria Based on (From Department of Defense 2006)

Consequence	Level	Technical Performance	Schedule	Cost
	1	Minimal or no consequence to technical performance	Minimal or no impact	Minimal or no impact
	2	Minor reduction in technical performance or supportability, can be tolerated with little or no impact on program; same approach retained	Additional activities required, able to meet key dates. Slip < 2 weeks	Budget increase or unit production cost increases > 1% of Budget
	3	Moderate reduction in technical performance or supportability with limited impact on program objectives; workarounds available	Minor schedule slip, no impact to key milestones. Slip < 1 months	Budget increase or unit production cost increase > 5% of Budget
	4	Significant degradation in technical performance or major shortfall in supportability; may jeopardize program success; workarounds may not be available or may have negative consequences	Program critical path affected, all schedule float associated with key milestone exhausted Slip < 2 months	Budget increase or unit production cost increase 10% of Budget
	5	Severe degradation in technical performance; Cannot meet KPP or Key technical/supportability threshold; will jeopardize program success; no workarounds available	Cannot meet key program milestones Slip > 2 months	Exceeds APBA threshold 10% of Budget

Figure 46. Risk Consequence Criteria Based on (From Department of Defense 2006)

The top five risks identified for each of the two alternatives and the associated likelihood and consequence ranking for the failure to provide the end users adequate biofuel end state of concern are shown in Table 12. These risks were then placed into a risk matrix for each of the two alternatives where the number shown is an index to the top five risks. These risk matrices, shown in Figure 47, allow for a direct comparison of the risk of the truck option and the combined option failing to provide adequate biofuel to the end user. It is important to note that of the four top-level system functions; only the transportation function can act as a discriminator between the two alternatives. The mixing, storage and distribution functions remain constant between the alternatives; therefore the risks associated with these functions were identical.

Truck Option			
ID	Level	Title	Description
1	C2	Trucks Delayed Due to Weather	There is a technical risk that insufficient quantity of biofuel will be transported due to weather delaying the trucks.
2	A3	Mixing with Incorrect Ratios	There is a technical risk that the biofuel will be mixed incorrectly due to improper amounts of biokerosene, additives and JP-X added to the mixing tank.
3	A3	Filter/Separator Systems Failure	There is a technical risk that the biofuel will be contaminated in transit due to fuel/separator failure.
4	A3	Commingling of New and Aged Biofuel	There is a technical risk that the biofuel will be contaminated in storage due to new fuel being mixed with old fuel.
5	A3	Insufficient Biofuel Stored - Unplanned Surge	There is a technical risk that an insufficient quantity of biofuel will be stored due to an unplanned surge in demand.

Combined Option			
ID	Level	Title	Description
1	C1	Trucks Delayed Due to weather	There is a technical risk that insufficient quantity of biofuel will be transported due to weather delaying the trucks.
2	A4	Pipeline Integrity	There is a technical risk that an insufficient quantity of biofuel will be transported through the pipeline due to a compromise of the pipelines integrity.
3	A3	Mixing with Incorrect Ratios	There is a technical risk that the biofuel will be mixed incorrectly due to improper amounts of biokerosene, additives and JP-X added to the mixing tank.
4	A3	Pipeline Blockage	There is a technical risk that an insufficient quantity of biofuel will be transported through the pipeline due to a blockage in the pipeline.
5	A3	Insufficient Biofuel Stored - Unplanned Surge	There is a technical risk that an insufficient quantity of biofuel will be stored due to an unplanned surge in demand.

Table 12. Top Five Risks of Failing to Provide the End User Adequate Biofuel

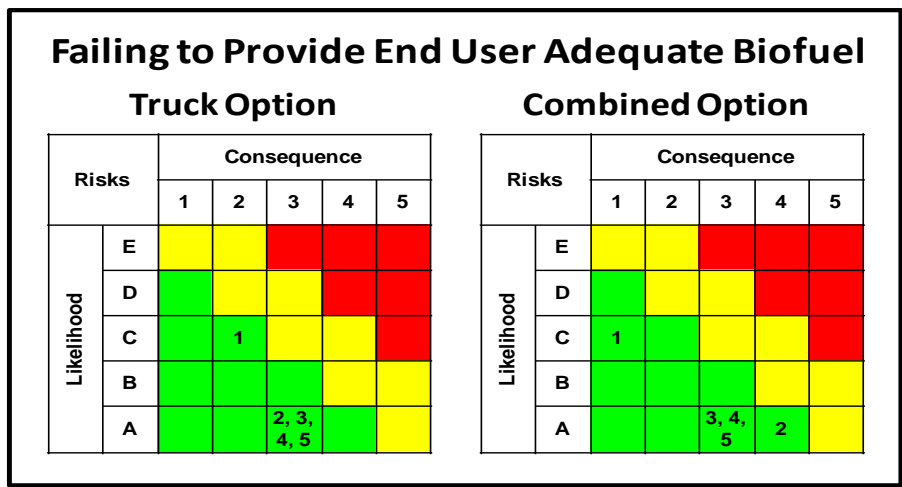

Figure 47. Risks - Failure to Provide Adequate Biofuel

Similarly, the top five risks identified for each of the two alternatives and the associated likelihood and consequence ranking for the failure to prevent a biofuel spill or hazard are shown in Table 13. These risks were then placed in to a risk matrix for each of the two alternatives where the number shown is an index to the list of top five risks. These risk matrices, shown in Figure 48, allow for a direct comparison of the risk of the truck option and the combined option failing to prevent a biofuel spill. As with the previous state of concern, only the transportation function can act as a discriminator between the two alternatives. The mixing, storage and distribution functions do not change between the alternatives, therefore the risks associated with these functions remain identical.

Truck Option			
ID	Level	Title	Description
1	C4	Hazmat spill from transportation truck (Traffic Accident)	There is a technical risk that there will be a Hazmat spill if a transportation truck's integrity is compromised due to a leak caused by a traffic accident.
2	B2	Hazmat spill during distribution (Truck Collision)	There is a technical risk that there will be a Hazmat spill during distribution if the fuel truck leaks due to a collision.
3	A3	Hazmat spill during Mixing (Natural Disaster)	There is a technical risk that there will be a Hazmat spill during the mixing process if a natural disaster (hurricane, typhoon or volcanic eruption) occurs.
4	A3	Hazmat spill during Mixing (Intentional Act)	There is a technical risk that there will be a Hazmat spill during the mixing process due to an intentional act (terrorist act).
5	A3	Hazmat spill from storage tanks (Intentional Act)	There is a technical risk that there will be a Hazmat spill during storage due to an intentional act (terrorist act).
Combined Option			
ID	Level	Title	Description
1	C3	Hazmat spill from transportation truck (Traffic Accident)	There is a technical risk that there will be a Hazmat spill if a transportation truck's integrity is compromised due to a leak caused by a traffic accident.
2	B2	Hazmat spill during distribution (Truck Collision)	There is a technical risk that there will be a Hazmat spill during distribution if the fuel truck leaks due to a collision.
3	A4	Hazmat spill from transportation pipeline (Intentional Act)	There is a technical risk that there will be a Hazmat spill if the transportation pipeline's integrity is compromised by an intentional act (terrorist act).
4	A3	Hazmat spill during Mixing (Natural Disaster)	There is a technical risk that there will be a Hazmat spill during the mixing process if a natural disaster (hurricane, typhoon or volcanic eruption) occurs.
5	A3	Hazmat spill during Mixing (Intentional Act)	There is a technical risk that there will be a Hazmat spill during the mixing process due to an intentional act (terrorist act).

Table 13. Top Five Risks of Failing to Prevent a Biofuel Spill

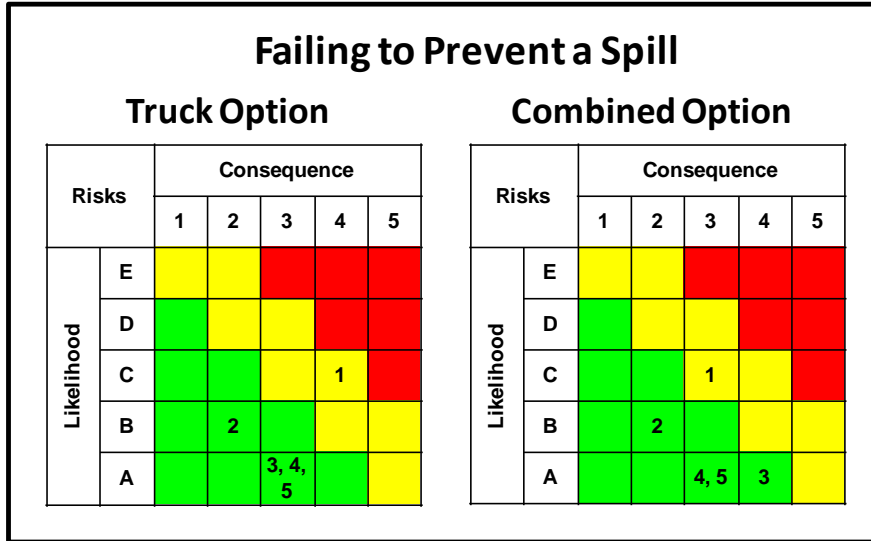

Figure 48. Risks - Failure to Prevent Biofuel Spill

Additionally, a quantitative analysis was performed to compare the probability of a biofuel spill for each of the distribution alternatives. As stated in the AOA section of the report, the truck only alternative is based on trucks transporting the biofuel from the mixing site at the refinery to each of the end user sites. The fixed distance from the refinery to the end users, the amount of biofuel to be delivered and the amount of fuel transported by each truck allows us to calculate the total miles that trucks will be traveling each year, shown in Table 14.

Roundtrip Distance from Refinery (miles)	Location		
	<b>JBPHH</b>	<b>MCBH</b>	<b>Wheeler</b>
	40	68	32
Annual Req. Trips 5,000 Gal	7460	1000	120
Annual Req. Trips 6,500 Gal	5738	769	92
Annual Req. Trips 8,000 Gal	4663	625	75
Annual Req. Miles 5,000 Gal	298,400	68,000	3,840
Annual Req. Miles 6,500 Gal	229,538	52,308	2,954
Annual Req. Miles 8,000 Gal	186,500	42,500	2,400

Table 14. Distance Travelled Annually for Truck Option

From the Accident Analysis and Prevention 32 (2000) 797–804, Button and Reilly, we were able to determine estimates for the expected number of incidents involving a truck that include a hazardous material spill annually (Button et al. 2000). This converted from Billion Vehicle Kilometer (BVKM) into vehicle miles at which point we were able to generate the expected number of incidents for the truck only option for each of the proposed truckloads. This is summarized in Figure 49.

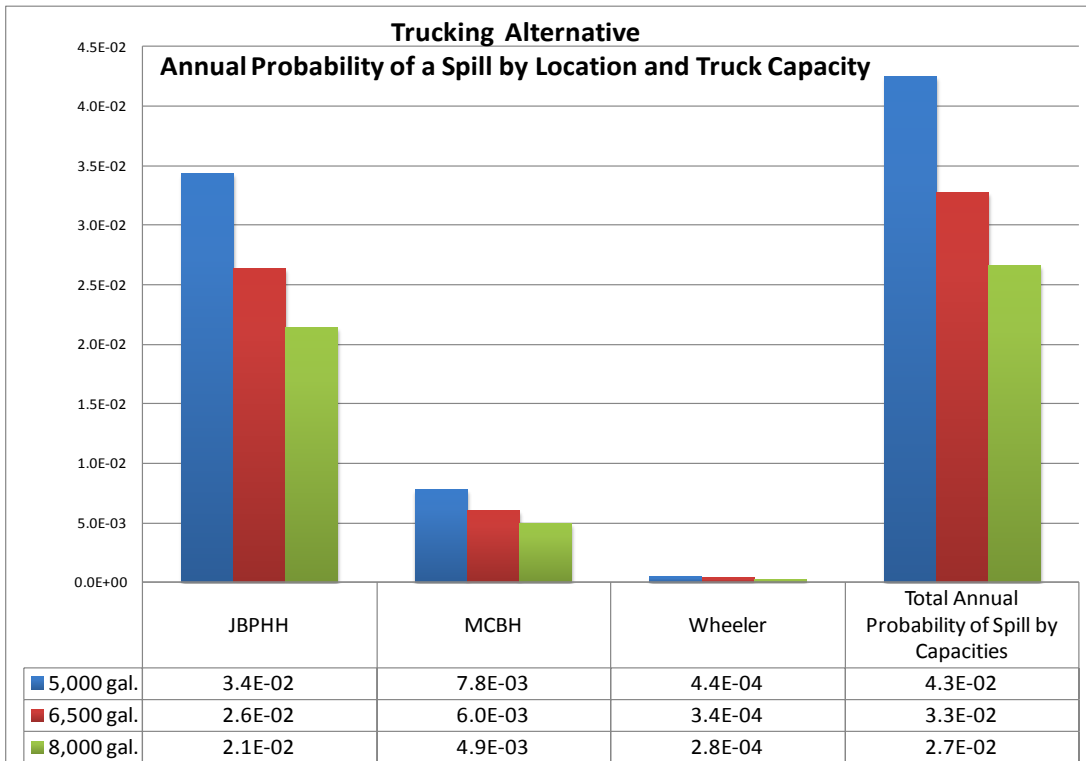

Figure 49. Annual Probability of a Spill – Truck Alternative

When calculating the probability of a spill for the combined option we took an approach that was similar to the truck only option. We determined the fixed distance from Red Hill Fuel Storage Facility to the end users at Wheeler Army Airfield and Marine Corps Base, Kaneohe Bay, the amount of biofuel to be delivered to each location and the amount of fuel transported by each truck allows us to calculate the total miles that trucks will be traveling each year. We then determined the number of miles that our fuel



will be traveling via a pipeline, which is equivalent to the distance from the refinery to the Red Hill and from the Red Hill to JBPHH.

Having determined the distances that our fuel is moving annually and having determined the expected number of spills for each mile travelled annually by truck, the final step was to determine a probability for each mile travelled annually for a pipeline. We decided to base this on data from a representative pipeline. Based on the data contained in the Draft Environmental Impact Statement, Keystone XL Pipeline Project for Dept. of State (DOS 2008), we estimated an expected value for spills greater than 50 barrels for each mile of pipeline used annually. The summary of the results is shown in Figure 50.

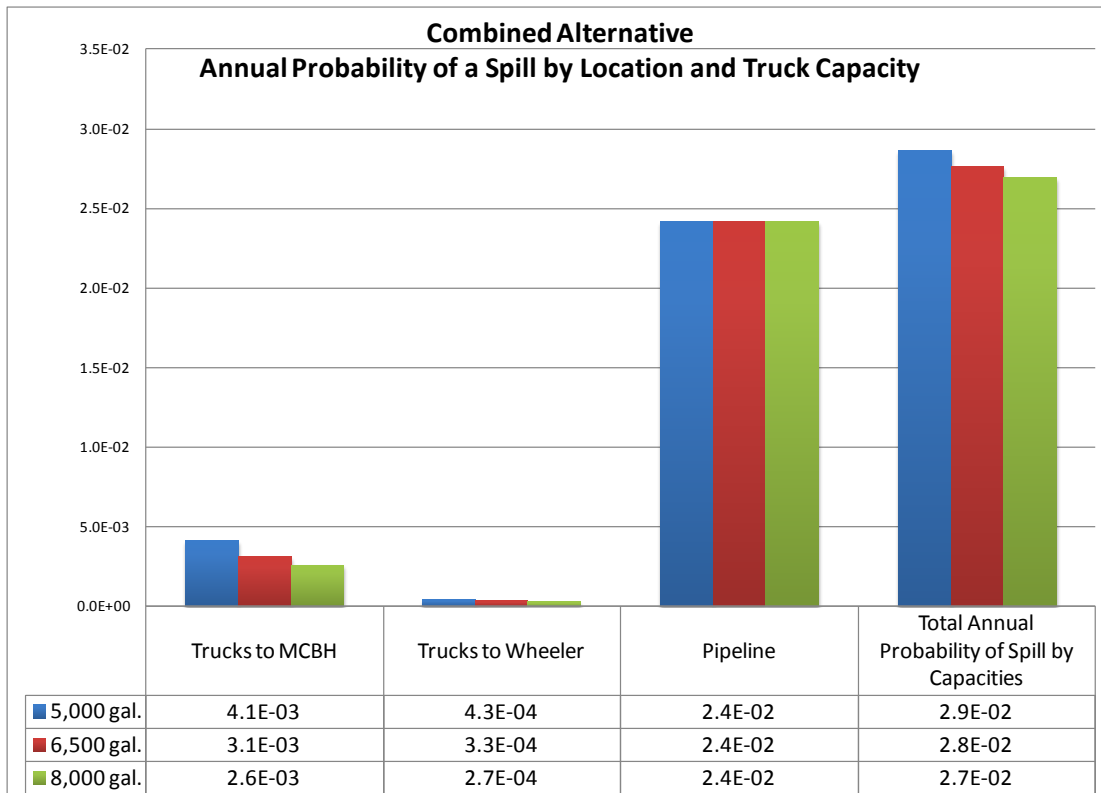

Figure 50. Annual Probability of a Spill – Combined Alternative

The results of the preceding analysis were placed side by side in Figure 51 to allow for direct comparison of the two alternatives. This shows that while each of the two

alternatives has some amount of risk of a spill associated with them, the Combined Alternative is the preferred choice since the expected spill rate is less than or equal to the truck only alternative.

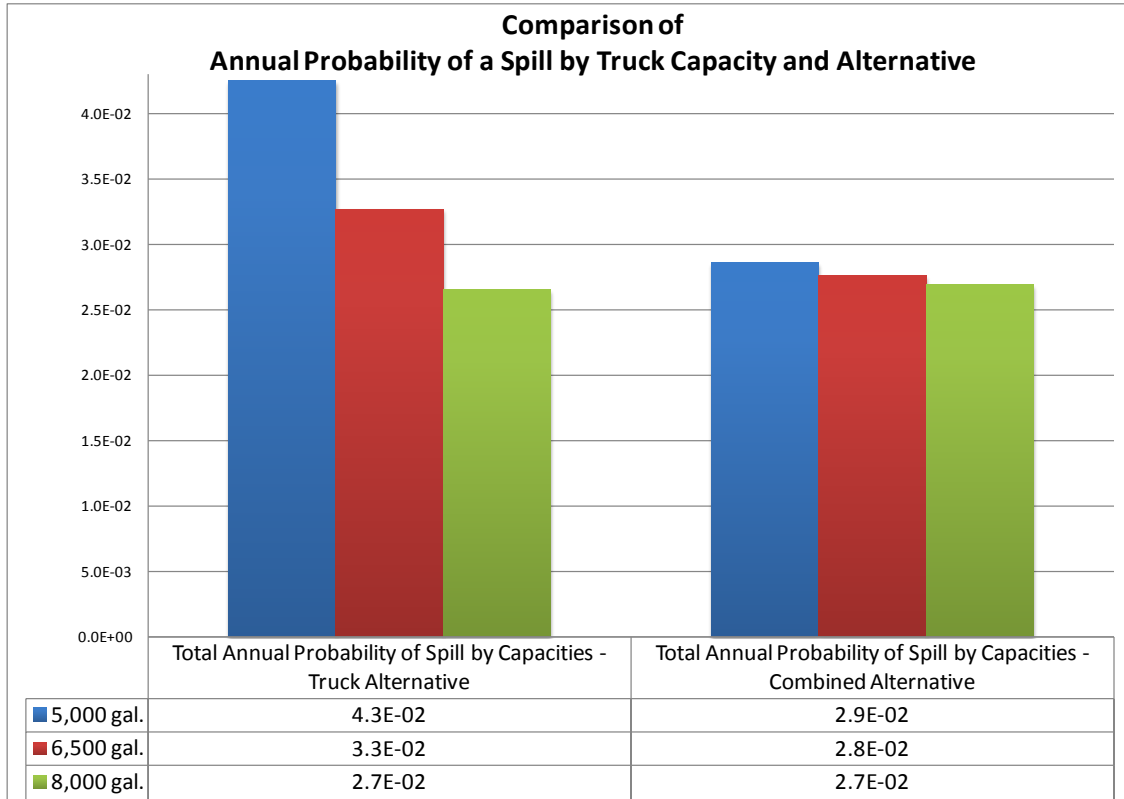

Figure 51. Annual Probability of a Spill – Alternative Comparison

#### D. ENVIRONMENTAL ANALYSIS

Environmental impact was the most important factor in the development of the BDS according to the primary stakeholder, PACOM. The biofuels team looked closely to the effects of the fuel distribution alternatives on the ecosystem. First and foremost the use of the pipeline to transfer the fuel from the most southwestern section of the island to either Red Hill storage facility or JBPHH saves approximately 17–20 miles one-way via tanker truck. With the approximate distance from the refinery to the Eastern most military installation at just over 32 miles, the ability to use the pipeline can reduce the truck run mileage on the order of 53–62%. The reduction in carbon emissions by over 50% is a

substantial reduction through the use of an existing pipeline structure. A complete pipeline system serving all existing military installations throughout the island is cost prohibitive according to DoD sources and was not a potential alternative. A pipeline that transfers 15,000 barrels per day would require 75 tanker truckloads per day, a load delivered every two minutes around the clock (AOPL 2013).

In addition to their efficiency, pipelines also have important environmental and safety benefits. In comparison to the use of tanker trucks, pipelines do not crowd our highways and they produce negligible air pollution. Pipelines also have a lower spill rate per barrel of oil transported than competing modes of transportation, namely trucks and barges (AOPL 2013).

Traditionally, older diesel engines produce more of the pollution associated with localized environmental trauma—such as smog and soot in the air—that can trigger respiratory and cardiovascular problems and have been linked to lung and other cancers (Scheer et al. 2012). The U.S. government has continued through the recent years in adopting increasingly stringent rules governing how much particulate pollution and other toxins are allowed to come out of diesel engines, the primary engine used to transport fuel trucks throughout the United States. In 2001, Congress started work to pass strict new pollution limits on heavy-duty trucks and buses. Most recently in 2012, President Obama announced new fuel efficiency and carbon pollution standards for heavy-duty trucks (Tonachel 2012).

The trucks covered by the Heavy Duty National Program (President Obama new fuel standards) include the tractors of combination tractor-trailers (“18-wheelers”), city buses, garbage haulers, delivery vehicles and work trucks over 8,500 lbs. These trucks consume about 20 percent of the oil used in the transportation sector and emit about 20 percent of transportation sector carbon pollution yet trucks represent only 4 percent of the vehicles on the roads. (Tonachel 2012)

In summarizing Environmental Analysis, the biofuel team noticed that with the large emphasis on creating a “green” fuel alternative in the production of biofuel, the environmental analysis’ goal was to provide the BDS alternative that best protects the ecosystem. Diesel trucks, as highlighted in the U.S. Government Heavy Duty National

Program, are a large part of the carbon pollution problem. Minimizing excess negative environmental factors lead the group to look at reducing the time and number of trucks that were on the road. Additionally, taking the primary stakeholders inputs into consideration, based on the results of the pairwise comparison the environmental impact had the greatest “weight” in the development of the BDS. The recommendation based on environmental impact is to minimize the use of tanker trucks and therefore the Combined Alternative is preferred.

#### **E. DETAILED ANALYSIS SUMMARY**

The results of the performance, cost, risk, and environmental analysis all recommend the Combined Alternative as the preferred system. The next step of the SE process is to combine the results into a single metric for further evaluation.

THIS PAGE INTENTIONALLY LEFT BLANK

## VI. OVERALL MEASURES OF EFFECTIVENESS

In order to determine the Overall Measure of Effectiveness (OMOE) of each alternative, we first calculated an OMOE function, which would provide a simple comparison for each alternative. The OMOE function was developed by reducing our AHP to three functions: environmental, capability, and usability/safety.

### A. OVERALL MEASURE OF EFFECTIVENESS ANALYSIS

The reduction of our AHP into three separate functions facilitated the development of a single OMOE function. These three functions were analyzed as described in Chapter 2: Capability was analyzed through the performance analysis; environmental through the environmental analysis, and usability/safety through the risk analysis. Stakeholder input determined the weights used to calculate the OMOE. These weights are shown in Table 15.

Function	Weight
Capability (Performance)	0.08
Environmental	0.67
Usability and Safety (Risk)	0.25

Table 15. MOP Weighting of Performance Functions

We then determined Values of Performance (VOPs) for each alternative within each function. The highest performing function received a value of 1 in that VOP, the lowest performing alternative received a value of 0. The remaining alternatives were given a value in between based on a linear relationship of the highest and lowest performing alternatives. The result of this process is shown in the following three sections.

#### 1. Capability

From the Analysis of Alternatives, the Truck option that proved to be the most efficient was the scenario with five trucks, each carrying 8000 gallons of biofuel.

Alternatively, the Combined option that proved to be the most efficient was the scenario with five trucks, each carrying 6500 gallons of biofuel. For comparison, a study was done to evaluate the VOP of all six options utilizing five trucks – the trucking and combined scenarios transporting 5000, 6500, and 8000 gallons of fuel, respectively. The truck scenarios are denoted: T5–5000, T5–6500, and T5–8000. The Combined scenarios are denoted C5–5000, C5–6500, and C5–8000. The number of hours and the amount of excess fuel were two factors that contributed to the VOP calculation. Each was given a weight of 0.5 and multiplied by the scaled value of time and excess, respectively. The two values were added together to achieve a total for VOP. From this table we can see that the scenario with the lowest VOP was the Truck option utilizing five trucks, all carrying 5000 gallons of biofuel. The scenario with the highest VOP was the Combined option, all carrying 8000 gallons of biofuel. The results of these calculations are shown in Table 16 and the graphical view of these results is shown in Figure 52.

Option	Time (hours) RAW	Time (hours) SCALED	Excess Gallons (millions) RAW	Excess Gallons (millions) SCALED	VOP
T5–5000	4296.50	0.00	53.20	0.00	0.00
T5–6500	3159.00	0.30	80.30	0.01	0.15
T5–8000	2652.00	0.44	106.40	0.01	0.22
C5–5000	770.00	0.93	4449.50	0.99	0.96
C5–6500	615.00	0.97	4502.10	1.00	0.99
C5–8000	519.00	1.00	4509.40	1.00	1.00

Table 16. VOP for Capability

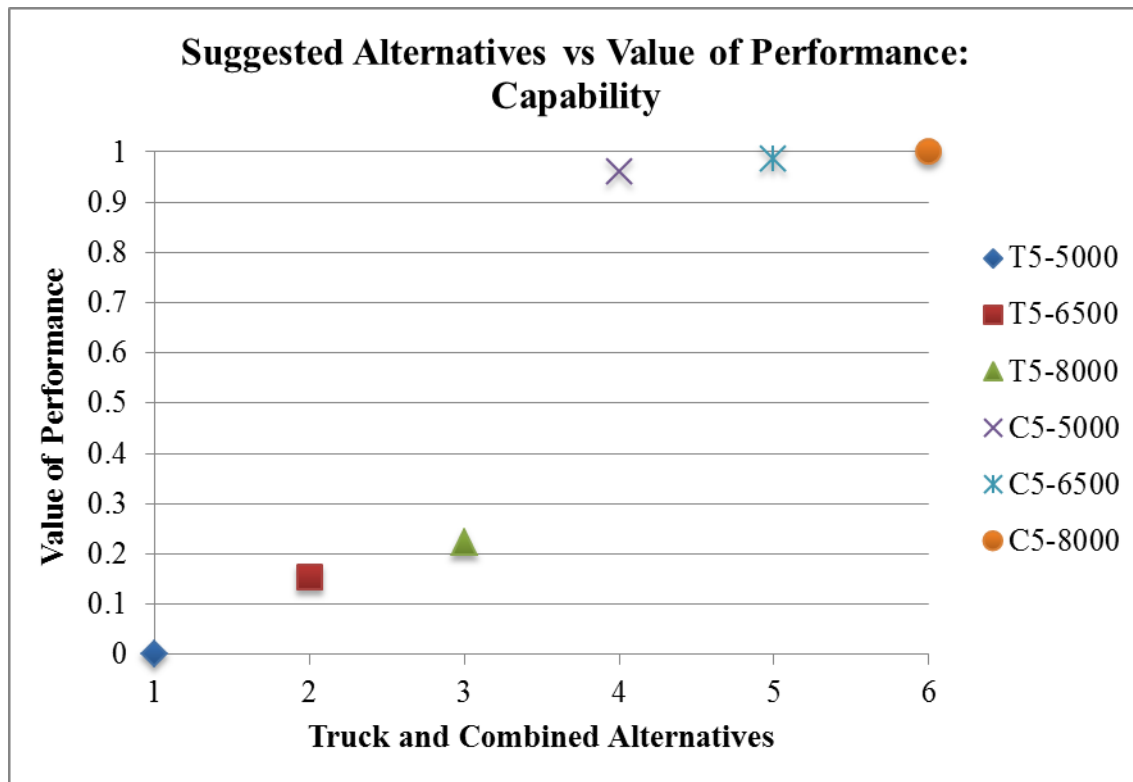

Figure 52. Suggested Alternatives vs. VOP: Capability

The x-axis represents the six different alternatives that were analyzed. The first three were truck alternatives: T5–5000, T5–6500, and T5–8000, and the second three were combined alternatives: C5–5000, C5–6500, and C5–8000. The y-axis represents the scaled VOP in terms of capability for each alternative. As shown in the previous table, the combined alternative with 5 trucks, each carrying 8000 gallons of biofuel ranked the highest in VOP and so it ranks highest on the y-axis.

## 2. Environmental

To maintain consistency, a similar environmental study was done by comparing the estimated amount of carbon dioxide emissions that would be released for all six scenarios in the period of one year. For the Trucking scenarios, this was done by calculating the round trip mileage for all three site deliveries from the refinery to storage location, and multiplying this mileage by the number of trips per day to each particular site. For the Combined scenarios, this was done by calculating the round trip mileage for



only two of the site deliveries, from Red Hill Storage to both MCBH and JBPHH, and multiplying this mileage by the number of trips per day to each particular site.

The calculation of carbon emission pounds released each year was found on a website developed by Roadnet Technologies. The actual equation for this calculation is not disclosed, however the calculation allows for specific inputs, and lists known assumptions. The known inputs include: the number of vehicles/routes per day, the estimated number of miles/routes per day, and the type of fuel consumed by the vehicle, all of which have been calculated. The only unknown input value is the miles per gallon (mpg) consumed based on the type of vehicle. However, in March of 2008, the U.S. DoE estimated that for a large truck or tractor-trailer, the consumption of diesel was approximately 6.5 miles per gallon, which was included as an assumption in the calculation of total carbon emissions. Additionally, there is a factor used to convert the number of metric tons of carbon emissions to pounds. This value is also not disclosed, but was verified by the DOE to be used in this calculation (Carbon Emissions Calculator 2012).

The VOP was calculated based on the amount of carbon emissions for each scenario. The Truck alternative that uses five trucks, each carrying 5000 gallons of biofuel was assigned the *lowest* VOP because it produces the *highest* amount of carbon dioxide emissions. In the Truck alternatives, the number of trips per site was calculated as a percentage of total desired fuel required of each military base. MCBH requires approximately 12% of the biofuel produced, while Wheeler Air Field requires approximately 1.5%, and JBPHH requires approximately 86.5% of the biofuel, respectively.

The Combined alternative that utilizes five trucks, each carrying 8000 gallons of biofuel was also determined to have the *highest* VOP because it also has the *lowest* amount of carbon dioxide emissions for a single year. It should be noted that in the Combined alternatives, the number of trucking trips per site was calculated as an even split between the total number of trips made each day. In reality, MCBH has a slightly higher need for biofuel than Wheeler Air Field, and so a greater number of trucks per day would travel to this location. However, the majority of the fuel is required to go to

JBPHH, which is being fulfilled by the use of the pipeline. Therefore, a 50/50 split between the 13.5% of remaining biofuel is not a gross misrepresentation in either case. Table 17 and Figure 53 summarize the data used in the calculation for the six alternatives.

Alternative	Trip	Distance one way	Round trip Mileage	Number of Deliveries per day	Carbon Emissions per year (thousand pounds)	RAW Total	SCALED VOP
<b>T5-5000</b>	Refinery to MCBH	32.5	65	6.3	368		
	Refinery to Pearl	19.4	38.8	45.34	1580.9		
	Refinery to Wheeler	15.7	31.4	0.76	21.45		
					>	<b>1970.35</b>	0.00
<b>T5-6500</b>	Refinery to MCBH	32.5	65	6.23	363.9		
	Refinery to Pearl	19.4	38.8	44.82	1562.76		
	Refinery to Wheeler	15.7	31.4	0.75	21.16		
					>	<b>1947.82</b>	0.08
<b>T5-8000</b>	Refinery to MCBH	32.5	65	6.13	358.06		
	Refinery to Pearl	19.4	38.8	44.13	1538.7		
	Refinery to Wheeler	15.7	31.4	0.74	20.88		
					>	<b>1917.64</b>	0.18
<b>C5-5000</b>	Red Hill to MCBH	17.1	34.2	30.70	943.50		
	Red Hill to Wheeler	15.4	30.8	30.70	849.70		
					>	<b>1793.2</b>	0.61
<b>C5-6500</b>	Red Hill to MCBH	17.1	34.2	29.80	915.90		
	Red Hill to Wheeler	15.4	30.8	29.80	824.80		
					>	<b>1740.7</b>	0.79
<b>C5-8000</b>	Red Hill to MCBH	17.1	34.2	28.75	883.60		
	Red Hill to Wheeler	15.4	30.8	28.75	795.70		
					>	<b>1679.3</b>	1.00

Table 17. Summary of Carbon Emission VOPs for Alternatives

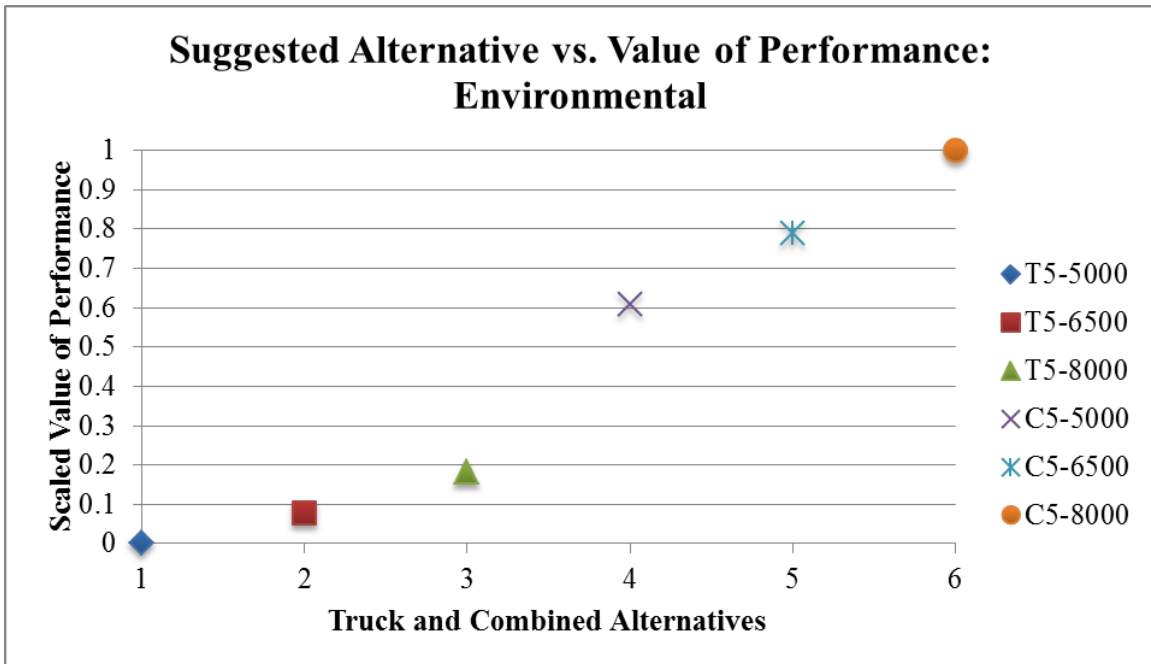

Figure 53. Suggested Alternatives vs. VOP: Environmental

The x-axis represents the six different alternatives that were analyzed. The first three were truck alternatives: T5-5000, T5-6500, and T5-8000, and the second three were combined alternatives: C5-5000, C5-6500, and C5-8000. The y-axis represents the scaled VOP in terms of environmental hazards for each alternative. As shown in the previous table, the combined alternative with 5 trucks, each carrying 8000 gallons of biofuel ranked the highest in VOP and so it ranks highest on the y-axis.

### 3. Usability and Safety

Similar to the previous two studies, a Usability/ Safety study was conducted to estimate the total risk among all six alternatives. The values that were used to determine the VOP were taken from the risk comparisons for the annual probability of a spill by truck capacity for both the Truck alternative and the Combined alternative. Table 18 summarizes the VOP results.

Alternative	Annual Probability of a Spill by Truck	
	Raw Probability	Scaled VOP
T5-5000	0.043	0.00
T5-6500	0.033	0.63
T5-8000	0.027	1.00
C5-5000	0.029	0.88
C5-6500	0.028	0.94
C5-8000	0.027	1.00

Table 18. Raw Values of Risk for Trucking and Combined Alternatives

The Truck and Combined alternatives with 5 trucks, each carrying 8000 gallons of biofuel tied for the highest VOP. It is important to note that these alternatives had the *highest* VOP because both had the *lowest* calculated value of risk. All Combined alternatives scored very high in VOP, however the two other Truck alternatives scored significantly lower. Shown in Figure 54 is a graphical representation of these values.

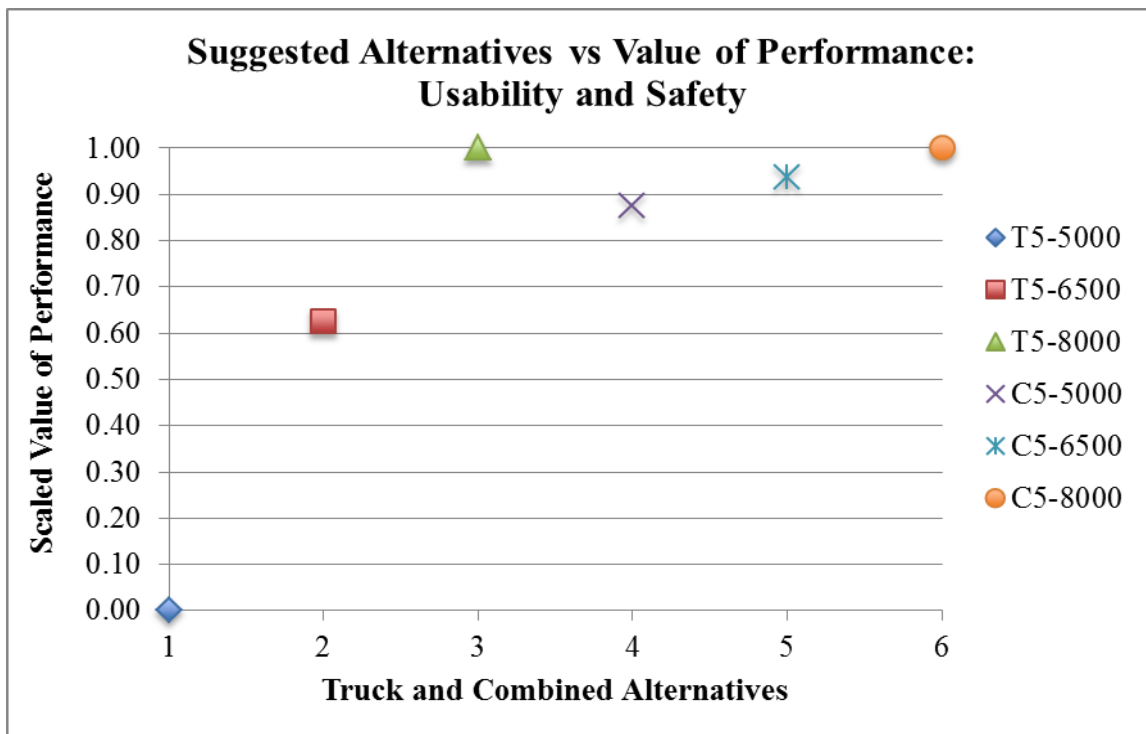

Figure 54. Suggested Alternatives vs. VOP: Usability and Safety

The x-axis represents the six different alternatives that were analyzed. The first three were truck alternatives: T5–5000, T5–6500, and T5–8000, and the second three were combined alternatives: C5–5000, C5–6500, and C5–8000. The y-axis represents the scaled VOP in terms of usability/ safety for each alternative. Again, all Combined alternatives scored very high in VOP, yet the Truck and Combined alternatives of 5 trucks with each carrying 8000 gallons tied for the highest VOP.

**B. TOTAL OVERALL MEASURE OF EFFECTIVENESS**

The total OMOE was calculated for each alternative by multiplying the weights of Capability, Environmental, and Usability/Safety by the VOP of each scenario, respectively, and then summed together to determine the total OMOE. The results are shown in Table 19.

	AHP Weights	Values of Performance					
		Truck: 5–5K Gal	Truck: 5–6.5K Gal	Truck: 5–8K Gal	Combined: 5–5K Gal	Combined: 5–6.5K Gal	Combined: 5–8K Gal
Capability	0.08	0	0.15	0.22	0.96	0.99	1
Environmental	0.67	0	0.08	0.18	0.61	0.79	1
Usability and Safety	0.25	0	0.63	1	0.88	0.94	1
<b>Total MOE</b>	1	0.00	0.22	0.39	0.71	0.84	1.00

Table 19. Total MOE for all Truck and Combined Alternatives

The team then plotted the OMOEs against Cost in order to assess the Performance versus Cost relationship. It is important to do this cost as an independent variable (CAIV) analysis to ensure that we can understand the trade space between performance and cost. The result is shown in Figure 55:

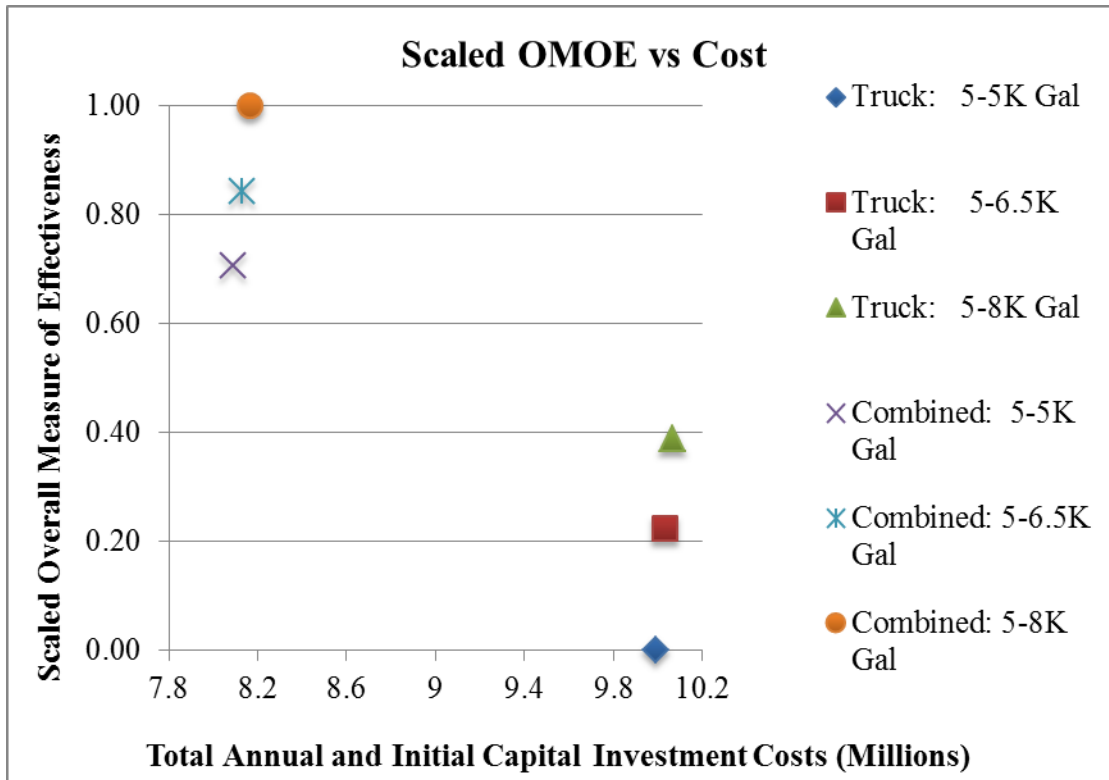

Figure 55. OMOE vs. Cost

From Figure 55 we can clearly see that the Combined 5–8K Gal alternative provides unmatched performance at a significantly lower cost than any of the Truck alternatives.

### C. OVERALL MEASURE OF EFFECTIVENESS SUMMARY

An OMOE process was used to determine the overall VOP of each alternative. Although all three Combined alternatives strongly outperform the Truck alternatives, the Combined 5–5K Gal and 5–6.5K Gal alternatives are not recommended because for a slightly higher cost, the system could yield greater effectiveness in the Combined 5–8K Gal alternative. The Truck 5–8K Gal alternative outmatches the other truck alternatives in performance, but also ranks the highest among any alternative in terms of cost, so this is also not a preferred alternative. The Truck 5–5K alternative would not be recommended because it has the lowest OMOE of any alternative, and still costs more than any of the combined alternatives.

THIS PAGE INTENTIONALLY LEFT BLANK

## **VII. SUMMARY, CONCLUSIONS, AND RECOMMENDATIONS**

### **A. CAPSTONE PROJECT SUMMARY**

The Biofuels Team took the first steps in developing a dedicated biofuel distribution system on the island of Oahu, Hawaii. Our primary focus was to develop a system to mix, transport, store, and distribute biofuel that meets the PACOM requirement of replacing 25% of aviation fuel consumed on the island with algae-based fuel. The transportation and distribution analysis complemented the work of another cohort working in tandem on the production process of the biofuel, and these two projects are a step along the path of greater energy independent for the Department of Defense and the United States.

The Biofuels Team applied a basic SE process that defined the problem, analyzed the system from a stakeholder, requirement, and environmental viewpoint. Next, CORE modeling software was used to document the functional architecture of the BDS. The team then built a simulation model using ExtendSim to simulate the truck and combined pipeline/truck delivery methods. These two alternatives were simulated and detailed analysis was conducted on the results in terms of performance, cost, risk, and environmental impact. The results of the performance, risk, and environmental analysis were compared to overall cost through the use of an Overall Measure of Effectiveness (OMOE) process.

### **B. CAPSTONE PROJECT CONCLUSIONS**

Team Biofuels came to the conclusion that the Combined Alternative utilizing five 8,000-gallon trucks and an existing pipeline network is the preferred alternative. In this configuration, fuel is transported directly to Red Hill via pipeline. Fuel is then transported to Wheeler Army Airfield and MCBH via trucks. To transport the fuel to JBPHH, fuel is fed into a pipeline from Red Hill to JBPHH via an existing pipeline network.



### **C. CAPSTONE PROJECT RECOMMENDATIONS**

Our recommendation for future work consists of several activities. First, we recommend that routine inspections be conducted along the entire distribution system. This will ensure necessary repairs are accomplished in a timely manner in lieu of building new infrastructure. Next, we recommend that a process be put in place to ensure continued identification of opportunities for upgrades.

If we had more time to research this project, our future studies would include life cycle cost analysis (e.g., cost/feasibility studies on replacing more than 25% of aviation fuel required. Additionally, there would be research efforts into the integration of the BDS into existing fuel distribution networks on Oahu. Finally, the team recommends efforts to design a proof of concept experiment supplementing a small percentage of fuel.

## LIST OF REFERENCES

- Agency for Toxic Substances and Disease Registry 2005. s.v. "Public Health Assessment for Pearl Harbor Naval Complex." Edited by Julie Gerberding Springfield, VA: U.S. Department of Health and Human Services Public Health Service, Agency for Toxic Substances and Disease Registry, 2005.
- AOPL, "Why Pipelines." Accessed January 27, 2013. <http://www.aopl.org/aboutpipelines/>.
- Blanchard, Benjamin, and Wolter Fabrycky. *Systems Engineering and Analysis*. Upper Saddle River: Prentice Hall, 2011.
- Buede, Dennis. *The Engineering Design of Systems*. New York: John Wiley & Sons, 2009.
- Button, N.P., and P.M. Reilly. *Uncertainty in incident rates for trucks carrying dangerous goods*. *Accident analysis and prevention*. 32. no. 6 (2000): 797–804.
- Chanda, Michael et al. *Proposed Functional Architecture and Associated Benefits Analysis of a Common Ground Control Station for Unmanned Aircraft Systems*. Capstone Project, Naval Postgraduate School, 2010.
- Cichon, Meg. 2011. RenewableEnergyWorld.com, *U.S. Navy Fuels "Green Strike Force" with \$12Million Biofuels Contract*. Last modified December 8. Accessed September 20, 2012. <http://www.renewableenergyworld.com/rea/news/article/2011/12/u-s-navy-fuels-green-strike-force-with-12-million-biofuels-contract>.
- Crisp, Harry. 2007. INCOSE, *Systems Engineering Vision 2020*. Accessed January 29, 2013. <http://www.incose.org/ProductsPubs/products/sevision2020.aspx>.
- Cost of Adding E85 Fueling Capability to Existing Gasoline Stations: NREL Survey and Literature Search*, National Renewable Energy Laboratory, accessed February 12, 2013, <http://www.afdc.energy.gov/pdfs/42390.pdf>
- Defense Logistics Agency Energy. 2012. *Fact Book Fiscal Year 2011*. Accessed January 26, 2013. [http://www.energy.dla.mil/energy\\_enterprise/Documents/Fact%20Book%20FY2011%20Rev.pdf](http://www.energy.dla.mil/energy_enterprise/Documents/Fact%20Book%20FY2011%20Rev.pdf)
- Department of Defense. *Risk Management Guide for DoD Acquisition, Sixth Edition (Version 1.0)*. DoD Instruction, DoD, 2006.
- Det Norske Veritas (DNV), *Biofuel Infrastructure: Managing in an Uncertain Future*. Accessed February 12, 2013. [http://www.dnv.com/binaries/Biofuels Infrastructure position paper\\_tcm4-434418.pdf](http://www.dnv.com/binaries/Biofuels%20Infrastructure%20position%20paper_tcm4-434418.pdf).

- DoD Systems Management College. 2000. *Systems Engineering Fundamentals*. Accessed January 6, 2013. [https://cle.nps.edu/access/content/group/7fd0732e-58f7-49e4-a000-17d8216d664d/References/Other\\_References/systems\\_eng\\_fundamentals.pdf](https://cle.nps.edu/access/content/group/7fd0732e-58f7-49e4-a000-17d8216d664d/References/Other_References/systems_eng_fundamentals.pdf).
- Dumaine, Brian. *Navy Secretary Ray Mabus is betting that the service will get half its energy from renewables by 2020*. *Fortune Magazine*, September 3, 2012. CNN Money, A Service of CNN, Fortune and Money. <http://tech.fortune.cnn.com/2012/08/28/navy-mabus-green/>
- Edward Campbell. Phone interview with Richard Seriani. Marine Corps Base Hawaii, November 19, 2012.
- Environmental Protection Agency (EPA). 1972. Summary of the Clean Water Act. 33 USC S1251 et seq. <http://www.epa.gov/lawsregs/laws/cwa.html>
- . 1976. The Toxic Substance Control Act (TSCA). USC Title 15 Section 2601 et seq. <http://www.epa.gov/lawsregs/laws/tsca.html>
- . 1984. Resources Conservation and Recovery Act (RCRA). USC Title 42 Chapter 82. <http://www.epa.gov/agriculture/lrca.html>
- . 1990. The Pollution Prevention Act (PPA). USC Title 42 Section 13101 et seq. <http://www.epa.gov/lawsregs/laws/ppa.html>
- . 2012. The Clean Air Act (CAA). USC Title 42 Chapter 48. Last modified February 17, 2012. <http://www.epa.gov/air/caa/>
- Fueling America: Key Facts and Figures*, The Association for Convenience & Fuel Retailing, accessed February 12, 2013, [http://www.nacsonline.com/NACS/Resources/campaigns/GasPrices\\_2011/Documents/GasPriceKit2011.pdf](http://www.nacsonline.com/NACS/Resources/campaigns/GasPrices_2011/Documents/GasPriceKit2011.pdf)
- Government Accountability Office (GAO). 2009. *Biofuels: Potential Effects and challenges of Required Increases in Production and Use*. GAA-09-446. August 25, 2009. <http://www.gao.gov/products/GAO-09-446>
- Hoivik, T, 2013. *Operational Suitability* OA4603 Briefing Slides, Naval Postgraduate School.
- Hovensa Corporation. 2012. *Material Safety Data Sheets*. Accessed November 20. <http://www.hovensa.com/msds.html>
- The Interstate Technology & Regulatory Council (ITRC). 2011. *Technical/Regulatory Guidance Biofuels: Release Prevention, Environmental Behavior, and Remediation*. Accessed December 15, 2012. <http://www.itrcweb.org/Guidance/GetDocument?documentID=13>

- Investor Words, *Stakeholder Analysis*. Accessed February 2, 2013.  
[http://www.investorwords.com/8226/stakeholder\\_analysis.html](http://www.investorwords.com/8226/stakeholder_analysis.html).
- Jones, Forrest, and Kathleen Walter. Money News, *Energy Expert Schork: Mideast Tensions Might Push Oil Prices to \$200 a Barrel*. Last modified 2012. Accessed February 5, 2013. <http://www.moneynews.com/Markets/Schork-crude-oil-prices/2012/08/17/id/448913>.
- Kenneth Daubert (Plant Superintendent, Kapaia Power Station, Kaua'i Island Utility Cooperative), site visit by Patrick Knowles. September 13, 2012.
- Traversi, Steve, interview by Kristen Kerns. Polar Tank Trailer Hawaii Distributor Email correspondence, (February 12, 2013).
- Lancaster, Kris. 2008. *Environmental Laws Applicable to the Construction and Operation of Biodiesel Plants*. Environmental Protection Agency (EPA) EPA-907-B-08-001. December 2008: 23.  
<http://www.epa.gov/ipbpages/archive/v23/1235.htm>
- Levin, Carl, and John McCain. United States. 2012. U.S. Senate Committee on Armed Services. Senate Committee On Armed Services Completes Markup Of The National Defense Authorization Act For Fiscal Year 2013. Washington, 2012. Print.
- Marine Corps Base Hawaii. 2012. *Marine Aircraft Group 24*. Accessed September 20.  
<http://www.mcbh.usmc.mil/mag24/index.asp>.
- MEB Awarded Fuel Tank Replacement Contract at Craney Island Terminal, Portsmouth, VA*, MEB General Contractors, accessed February 12, 2013, <http://www.meb-inc.com/latest-news/98-meb-awarded-fuel-tank-replacement-contract-at-craney-island-terminal-portsmouth-va>
- MIL-DTL-55642U, Turbine Fuel, Aviation, Grades JP-4 and JP-5*. Revision U, 05 January 2004
- MIL-DTL-83133H, Turbine Fuel, Aviation, Kerosene Type, JP-8 (NATO F-34), NATO F-35, and JP-8+100 (NATO F-37)*. Revision H, 14 September 2012
- MIL-PRF-25017H, Inhibitor, Corrosion/Lubricity Improver, Fuel Soluble (NATO S-1747)*. Revision H, 04 August 2011
- MIL-DTL-85470B, Inhibitor, Icing, Fuel System, High Flash NATO Code Number S-1745*. Revision B, 15 June 1999
- National Weather Service Forecast Office, *NWS Home > Climate > NWS Honolulu > Climate Resources*. Last modified 21-Jul-2006. Accessed February 8, 2013.  
[http://www.nws.noaa.gov/climate/climate\\_resources.php?wfo=hnl](http://www.nws.noaa.gov/climate/climate_resources.php?wfo=hnl).

- OPEC. 2013. *OPEC Share of World Crude Oil Reserves*. Accessed January 20, 2013. [http://www.opec.org/opec\\_web/en/data\\_graphs/330.htm](http://www.opec.org/opec_web/en/data_graphs/330.htm).
- Parnell, Gregory S., Patrick Driscoll, and Dale Henderson, Editors, 2010. *Decision Making in Systems Engineering and Management*, 2nd ed. Wiley Publishing.
- Plains All American Pipeline, L.P. (2008). Form 10-K for the fiscal year ended December 31, 2008. Retrieved from [http://www.wikininvest.com/stock/Plains\\_All\\_American\\_Pipeline,\\_L.P.\\_\(PAA\)/Filing/10-K/2009/F5431563](http://www.wikininvest.com/stock/Plains_All_American_Pipeline,_L.P._(PAA)/Filing/10-K/2009/F5431563)
- Qureshi, Muhammad E., and Steve Harrison. 2003. *Application of the Analytic Hierarchy Process to Riparian Revegetation Policy Options*. Small-scale Forest Economics. Management and Policy, 23.
- Renewable Energy FAQ's*, Kauai Island Utility Cooperative, accessed September 16, 2012, <http://website.kiuc.coop/content/renewable-energy-faqs>
- Rhoades, Mark. 2012. *Lecture: Risk Analysis and Management for Engineering Systems, NASA Probabilistic Risk Assessment SE4353 Briefing Slides*, Naval Postgraduate School.
- Roadnet Technologies, *Carbon Emissions Calculator*. Accessed February 10, 2013. <http://www.roadnet.com/pages/products/carbon-emissions/index.aspx>.
- Roughead, Gary, James Conway, and Thad Allen. 2010. U.S. Military. Accessed December 27, 2012. <http://www.navy.mil/maritime/noc/NOC2010.pdf>.
- Scheer, Roddy, and Doug Moss. The Environmental Magazine, *Diesel Fuel Pollution*. Accessed February 9, 2013. <http://www.emagazine.com/earth-talk/diesel-fuel-pollution>.
- Saaty, T L. *The Analytic Hierarchy Process*. New York: McGraw Hill International, 1986. *Axiomatic Foundation of the Analytic Hierarchy Process*. Management Science 32, no. 7: 841–855.
- Siah, Marc, ed. Honolulu, Hawaii: State of Hawaii - Department of Transportation, Harbors Division, 2009. s.v. *Statewide Fuel Facilities Development Plan*.
- Simonpietri, Joelle. 2011. *Hawaii Energy Policy Forum*. University of Hawaii at Manoa. May 20, 2011. <http://www.hawaiienergypolicy.hawaii.edu/PDF/2011/2011-5-20-Joelle-Simonpietri.pdf>.
- U.S. Department of Energy. *Research and Development Opportunities for Heavy Trucks*. U.S. Department of Energy: Energy Efficiency and Renewable Energy Division. Accessed February 11, 2013. [http://www1.eere.energy.gov/vehiclesandfuels/pdfs/truck\\_efficiency\\_paper\\_v2.pdf](http://www1.eere.energy.gov/vehiclesandfuels/pdfs/truck_efficiency_paper_v2.pdf).

- U.S. DOE Alternative Fuels Data Center 2012 U.S. Department of Energy, *Alternative Fuels Data Center*. Accessed September, 2012.  
[http://www.afdc.energy.gov/fuels/emerging\\_dropin\\_biofuels.html](http://www.afdc.energy.gov/fuels/emerging_dropin_biofuels.html).
- U.S. Department of the State, Keystone XL Pipeline Project. *Draft Environmental Impact Statement (EIS): Oil Spill Risk Assessment and Environmental Consequence Analysis*. Washington, DC: U.S. Department of the State, New Keystone Pipe Application, 2008. Accessed February 13, 2013. <http://keystonepipeline-xl.state.gov/documents/organization/182344.pdf>.
- U.S. Department of the Transportation, Pipeline and Hazardous Materials Safety. *Incident Statistics*. Washington, DC: U.S. Department of the Transportation, Hazmat Safety Community 2004–2013. Accessed February 13, 2013.  
<http://www.phmsa.dot.gov/hazmat/library/data-stats/incidents>.
- U.S. Energy Information Administration from Oil and Gas Journal. 2007. *World Oil Reserves by Region.PNG*. Last modified 2007. Accessed December 20, 2012.  
[http://en.wikipedia.org/wiki/File:World\\_Oil\\_Reserves\\_by\\_Region.PNG](http://en.wikipedia.org/wiki/File:World_Oil_Reserves_by_Region.PNG).
- U.S. Pacific Command Public Affairs. 2009 *PACOM Signs Energy Strategy in Cooperation with the State of Hawaii*. Accessed December 23, 2012.  
<http://www.pacom.mil/media/press-releases/2009/pr-012-09-pacom-signs-energy-strategy-cooperation-hawaii.shtml>.
- Vaidyanathan, Ravi. 2011. *Lecture 2: Basic Systems Engineering Models*. Course SE3100 briefing slides, Naval Postgraduate School.

THIS PAGE INTENTIONALLY LEFT BLANK

## APPENDIX A: STAKEHOLDER INTERVIEWS

The Biofuels team’s first meetings with potential stakeholders occurred during a Naval Postgraduate School-sponsored trip to Hawaii the week of 10 Sept 2012. Patrick Knowles and Roge Adversalo traveled to Hawaii with Prof. Olwell’s NAVAIR cohort to meet with the various biofuel initiative stakeholders that included algae producers, refineries, educational institutions, and various government organizations as identified in Table 20. The results of the initial meetings are summarized below.

<b>Date</b>	<b>Stakeholder</b>	<b>Format</b>
11-Sep	PACOM	Free discussion
11-Sep	Kuehnle AgroSystems	Free discussion/Tour
11-Sep	State of Hawaii Natural and Water Resources	Free discussion
11-Sep	Hawaii State Energy Office	Free discussion
12-Sep	University of Hawaii, Manoa, Hawaii Natural Energy Institute	Free discussion
12-Sep	Aloha Petroleum, LTD	Free discussion
12-Sep	DLA	Free discussion
12-Sep	USCG	Free discussion
13-Sep	Kauai Island Utility Cooperative	Free discussion
13-Sep	University of Hawaii, Manoa, Molecular Biosciences and Bioengineering	Free discussion
13-Sep	Hawaii Electric Company	Free discussion/Tour
13-Sep	Honeywell, Unit Operations (UOP)	Free discussion/Tour
14-Sep	Cellana	Free discussion
14-Sep	Pacific Biodiesel	Free discussion
14-Sep	Chevron Refinery	Free discussion

Table 20. Hawaii Visit Itinerary

### A. KAUAI ISLAND UTILITY COOPERATIVE

Kauai Island Utility Cooperative serves approximately 32,700 electric accounts on the island of Kauai. They currently produce approximately 92% of their electricity by burning fossil fuels and are actively seeking renewable resources to generate as much as 50% of their electricity output by 2023 (KIUC 2012). The two cohorts visited Kapaia



Power Station, a component of Kauai Island Utility Cooperative, was a neighbor and past partner of the General Atomics / Hawaii BioEnergy, Limited Liability Company project that was funded by the Defense Advanced Research Projects Agency to demonstrate open pond production of algae for biofuels on Kauai. The Kapaia Power Station is a steam-injected gas turbine power plant that produces 27.5 MW of energy; 20 MW from the gas turbine and the remaining 7MW with a steam turbine that captures waste heat from the gas turbine (Daubert 2012). The power station is one of two power plants on the island of Kauai, which together provide 90% of the power requirements of the island. The remaining 10% of the island's energy is generated from hydro and wind sources. The fuel that the plant burns is delivered to the island by barge then brought to the power plant by truck. The plant receives seven 9,000-gallon tank trucks per day (Daubert 2012).

## **B. CELLANA**

The cohorts visited Cellana on the island of Hawaii. Cellana, formerly HR BioPetroleum Inc. cofounded by Royal Dutch Shell PLC, utilizes both closed photobioreactors and open ponds to grow algae at its pilot facility in Kona. They currently produce feedstocks for biofuels using microalgae at the demo facility located in Kona, Hawaii. Cellana's site is primarily a research center versus a production plant. They are actively researching optimal algae strains for production using their patented hybrid photobioreactor for pond algae growth called Alduo. The technology for microalgae has been successful however research is still in a small-scale production phase for efficiently removing lipids from the feedstock to produce biofuels. Cellana ships their dried algae product off-island after dewatering and dehydration steps in 15 kg bags. The scaling challenges at this point are not the algae growth method but the cost involved with processing the algae by dewatering, drying, and lipid separation, which require larger energy inputs for relative small output.

## **C. PACIFIC BIODIESEL**

Pacific Biodiesel is headquartered in Kahului, Hawaii and is recognized as one of the first commercially viable biodiesel plants in the United States. Their primary stock for biodiesel refinement is used cooking oil and grease trap waste from local Hawaiian island

restaurants. Their output product is “intended to be used as a replacement for petroleum diesel fuel, or can be blended with petroleum diesel fuel in any proportion.” Their biodiesel product does not require modifications to a diesel engine to be used and is governed by ASTM D 6751 quality parameters.

The owner of Pacific Biodiesel conducted the entire visit at Pacific Biodiesel and facility tour. Pacific Biodiesel has its roots in engineering the biodiesel production process and is affiliated with Pacific Biodiesel Technologies (Salem, Oregon), which over the past 15 year has been improving its production processes. Pacific Biodiesel Technologies “provides engineering, equipment, contracting, and laboratory services needed for profitable community-based production of ASTM quality biodiesel from multiple feedstocks.” Pacific Biodiesel Technologies is a possible supplier and consultant for processing biodiesel.

#### **D. STATE OF HAWAII NATURAL AND WATER RESOURCES**

The Hawaii State government was threatened with a fine by the Environmental Protection Agency (EPA) if they did not replace deteriorating water pipes and a Federal judge mandated the State government to fix the water pipes at an estimated cost of roughly \$2 billion. During their presentation, the State of Hawaii Water Commission recommended the incorporation of beneficial uses such as redirecting wastewater to grow algae in ponds. The main take-away was that the Commissioner is very interested in finding ways to fix the existing infrastructure while contributing to the algae-based biofuel solution.

#### **E. STATE OF HAWAII ENERGY OFFICE**

They hosted a Programmatic Environmental Impact Statement (PEIS) scoping town-hall meeting event. The event held in Honolulu was chaired by U.S. Department of Energy from Washington, D.C., and attended by Hawaiians from all walks of life. They discussed ways to develop renewable energy in support of the clean energy bill. They also discussed agricultural, cultural, archeological, socio-economic, and legal impacts of the Hawaii Clean Energy Initiative. Renewable energy sources included wind power,

solar, ethanol, and biofuel. PEIS will analyze and publicize assessments but not provide solutions.

**F. UNIVERSITY OF HAWAII, MANOA, HAWAII NATURAL ENERGY INSTITUTE**

The representative presented information from his report “Analysis of Land Suitable for Algae Production, State of Hawaii.” The institute did a sensitivity analysis on available lands that can be used for cultivation of algae, and found that the land has to be less than 5% in slope for maximum production.

**G. UNIVERSITY OF HAWAII, MANOA, MOLECULAR BIOSCIENCES AND BIOENGINEERING**

The University of Hawaii, Manoa, Molecular Biosciences and Bioengineering school is researching the use of terrestrial plants to create biofuel. They are working with local landowners, such as the Hawaiian Commercial & Sugar Company, on converting from growing cash crops to producing biofuel crops.

**H. KUEHNLE AGROSYSTEMS**

Kuehnle AgroSystems (KAS) works with General Atomics in the cultivation and production of algae. They provided feedstock to get General Atomics facility started. KAS grows only indigenous to Hawaii wild algae strains. They collect information on the amount of oil harvested from each algae strain to determine its suitability for lipid cultivation. Chevron is hosting an algae-growing experiment for KAS that uses waste CO<sub>2</sub> from the refinery to feed the algae.

**I. HAWAIIAN ELECTRIC COMPANY**

The Hawaiian Electric Company (HECO) is the secondary power provider for Oahu with a capacity of 113 Mega Watts. HECO uses only pure biodiesel from processed animal fats in their power generators. The biodiesel is processed and refined in Iowa and brought to Honolulu via oil tankers. HECO is interested in a local source for biodiesel but is regulated on the quality of fuel that they can and can't use. The locally produced biofuel must be compatible with their diesel power generators.

## APPENDIX B: SYSTEM DESCRIPTION

Name	Number & Name	Description	Captured by	Consumed by	Produced by
Biofuel	RESOURCE.1 Biofuel	50/50 blend of JP-5 or JP-8 and biokerosene.	<p>FUNC.1.6.1.4 Store Biofuel post-mixing</p> <p>FUNC.1.6.1.4.1 Provide required quantity of storage</p> <p>FUNC.1.6.2 Transport</p> <p>FUNC.1.6.2.1 Receive biofuel from mixing storage</p> <p>FUNC.1.6.2.1.1 Remove biofuel from storage</p> <p>FUNC.1.6.2.1.2 Measure quantity removed from storage</p> <p>FUNC.1.6.2.2 Distribute biofuel to transportation method</p> <p>FUNC.1.6.2.2.1 Load biofuel on transportation method</p> <p>FUNC.1.6.2.2.2 Measure quantity to be transported</p> <p>FUNC.1.6.2.3 Transport biofuel</p> <p>FUNC.1.6.2.3.1 Ensure quality of transported biofuel</p> <p>FUNC.1.6.2.3.2 Transport biofuel via transportation method</p> <p>FUNC.1.6.3 Store</p> <p>FUNC.1.6.3.1 Receive biofuel from transportation method</p> <p>FUNC.1.6.3.2 Store biofuel</p> <p>FUNC.1.6.4 Distribute</p> <p>FUNC.1.6.4.1 Move biofuel from storage facilities</p> <p>FUNC.1.6.4.2 Transport biofuel to point of use</p> <p>FUNC.1.7 Receive and use biofuel</p>	<p>FUNC.1.6.4.3 Distribute biofuel to customer</p>	<p>FUNC.1.6 Provide biofuel</p> <p>FUNC.1.6.1 Mix</p> <p>FUNC.1.6.1.3 Mix elements</p> <p>FUNC.1.6.1.3.2 Mix biokerosene and JP-X</p>
JP-X	RESOURCE.2 JP-X	Generic petroleum-based fuel.	<p>FUNC.1.6.1.1 Receive fuel elements</p> <p>FUNC.1.6.1.1.2 Receive JP-X</p> <p>FUNC.1.6.1.2 Store elements prior to mixing</p> <p>FUNC.1.6.1.2.1 Store JP-X prior to mixing</p>	<p>FUNC.1.6 Provide biofuel</p> <p>FUNC.1.6.1 Mix</p> <p>FUNC.1.6.1.3.2 Mix biokerosene and JP-X</p>	<p>FUNC.1.1 Supply JP-X</p>
Biokerosene	RESOURCE.3 Biokerosene	Bio-based kerosene	<p>FUNC.1.6.1.1 Receive fuel elements</p> <p>FUNC.1.6.1.1.1 Receive</p>	<p>FUNC.1.6 Provide biofuel</p>	<p>FUNC.1.2 Supply Biokerosene</p>

Name	Number & Name	Description	Captured by	Consumed by	Produced by
			biokerosene FUNC.1.6.1.2 Store elements prior to mixing FUNC.1.6.1.2.2 Store biokerosene prior to mixing	FUNC.1.6.1 Mix FUNC.1.6.1.3 .1 Prepare biokerosene for mixing FUNC.1.6.1.3 .1.1 Mix biokerosene and mixing additive	
Mixing Additive	RESOURCE.4 Mixing Additive	Additives used in the mixing process	FUNC.1.6.1.1 Receive fuel elements FUNC.1.6.1.1.3 Receive Mixing Additive FUNC.1.6.1.2 Store elements prior to mixing FUNC.1.6.1.2.3 Store mixing additive prior to mixing	FUNC.1.6 Provide biofuel FUNC.1.6.1 Mix FUNC.1.6.1.3 .1 Prepare biokerosene for mixing FUNC.1.6.1.3 .1.1 Mix biokerosene and mixing additive	FUNC.1.3 Supply Mixing Additive
Prepared biokerosene	RESOURCE.5 Prepared biokerosene	Bio-kerosene prepared with mixing additives		FUNC.1.6.1.3 .2 Mix biokerosene and JP-X	FUNC.1.6.1.3.1 Prepare biokerosene for mixing FUNC.1.6.1.3.1.1 Mix biokerosene and mixing additive
Byproducts	RESOURCE.6 Byproducts	Hazardous byproducts of the mixing process		FUNC.1.8 Dispose of byproducts	FUNC.1.6 Provide biofuel FUNC.1.6.1 Mix FUNC.1.6.1.3 Mix elements FUNC.1.6.1.3.1.1 Mix biokerosene and mixing additive FUNC.1.6.1.3.2 Mix biokerosene and JP-X

### **FUNC.1.1 Supply JP-X**

Allocated To:  
COMP.1.7 DLA Suppliers

Table 1 FUNC.1.1 Supply JP-X, Interfacing Items

Interfacing Items	Source / Destination
Quantity Feedback for JP-X	Triggers Function(s): FUNC.1.1 Supply JP-X Output From: FUNC.1.6 Provide biofuel FUNC.1.6.1 Mix FUNC.1.6.1.4 Store Biofuel post-mixing FUNC.1.6.1.4.2 Communicate storage status

Produces Resource(s):  
 RESOURCE.2 JP-X

### **FUNC.1.2 Supply Biokerosene**

Allocated To:  
 COMP.1.4 Biofuel Refineries

Table 2 FUNC.1.2 Supply Biokerosene

<b>Interfacing Items</b>	<b>Source / Destination</b>
Quantity Feedback for Biokerosene	Triggers Function(s): FUNC.1.2 Supply Biokerosene Output From: FUNC.1.6 Provide biofuel FUNC.1.6.1 Mix FUNC.1.6.1.4 Store Biofuel post-mixing FUNC.1.6.1.4.2 Communicate storage status

Produces Resource(s):  
 RESOURCE.3 Biokerosene

### **FUNC.1.3 Supply Mixing Additive**

Allocated To:  
 COMP.1.7 DLA Suppliers

Table 3 FUNC.1.3 Supply Mixing Additive Items

<b>Interfacing Items</b>	<b>Source / Destination</b>
Quantity Feedback for Mixing Additive	Triggers Function(s): FUNC.1.3 Supply Mixing Additive Output From: FUNC.1.6 Provide biofuel FUNC.1.6.1 Mix FUNC.1.6.1.3 Mix elements FUNC.1.6.1.3.1 Prepare biokerosene for mixing FUNC.1.6.1.3.1.1 Mix biokerosene and mixing additive

Produces Resource(s):  
 RESOURCE.4 Mixing Additive

### **FUNC.1.4 Make Policy**

Allocated To:  
 COMP.1.6 Government Decision Makers

Table 4 FUNC.1.4 Making Policy

<b>Interfacing Items</b>	<b>Source / Destination</b>
Policy and Requirements	Triggers Function(s): FUNC.1.6 Provide biofuel Output From: FUNC.1.4 Make Policy

## **FUNC.1.5 Provide Infrastructure**

Allocated To:  
COMP.1.5 Existing Infrastructures

Table 5 FUNC.1.5 Provide Infrastructure

<b>Interfacing Items</b>	<b>Source / Destination</b>
Infrastructure Requirements	Triggers Function(s): FUNC.1.6 Provide biofuel Output From: FUNC.1.5 Provide Infrastructure

## **FUNC.1.6 Provide biofuel**

Allocated To:  
COMP.1.1 Biofuel Distribution System

Specified By Requirements:  
REQ.1 Originating Requirement

Table 6 FUNC.1.6 Provide Biofuel

<b>Interfacing Items</b>	<b>Source / Destination</b>
Customer Feedback	Triggers Function(s): FUNC.1.6 Provide biofuel Output From: FUNC.1.7 Receive and use biofuel
Infrastructure Requirements	Triggers Function(s): FUNC.1.6 Provide biofuel Output From: FUNC.1.5 Provide Infrastructure
Policy and Requirements	Triggers Function(s): FUNC.1.6 Provide biofuel Output From: FUNC.1.4 Make Policy
Quantity Feedback for Biokerosene	Triggers Function(s): FUNC.1.2 Supply Biokerosene

Interfacing Items	Source / Destination
	Output From: FUNC.1.6 Provide biofuel FUNC.1.6.1 Mix FUNC.1.6.1.4 Store Biofuel post-mixing FUNC.1.6.1.4.2 Communicate storage status
Quantity Feedback for JP-X	Triggers Function(s): FUNC.1.1 Supply JP-X Output From: FUNC.1.6 Provide biofuel FUNC.1.6.1 Mix FUNC.1.6.1.4 Store Biofuel post-mixing FUNC.1.6.1.4.2 Communicate storage status
Quantity Feedback for Mixing Additive	Triggers Function(s): FUNC.1.3 Supply Mixing Additive Output From: FUNC.1.6 Provide biofuel FUNC.1.6.1 Mix FUNC.1.6.1.3 Mix elements FUNC.1.6.1.3.1 Prepare biokerosene for mixing FUNC.1.6.1.3.1.1 Mix biokerosene and mixing additive

Consumes Resource(s):

RESOURCE.2 JP-X

Acquire Available: true

RESOURCE.3 Biokerosene

Acquire Available: true

RESOURCE.4 Mixing Additive

Acquire Available: true

Produces Resource(s):

RESOURCE.1 Biofuel

Byproducts



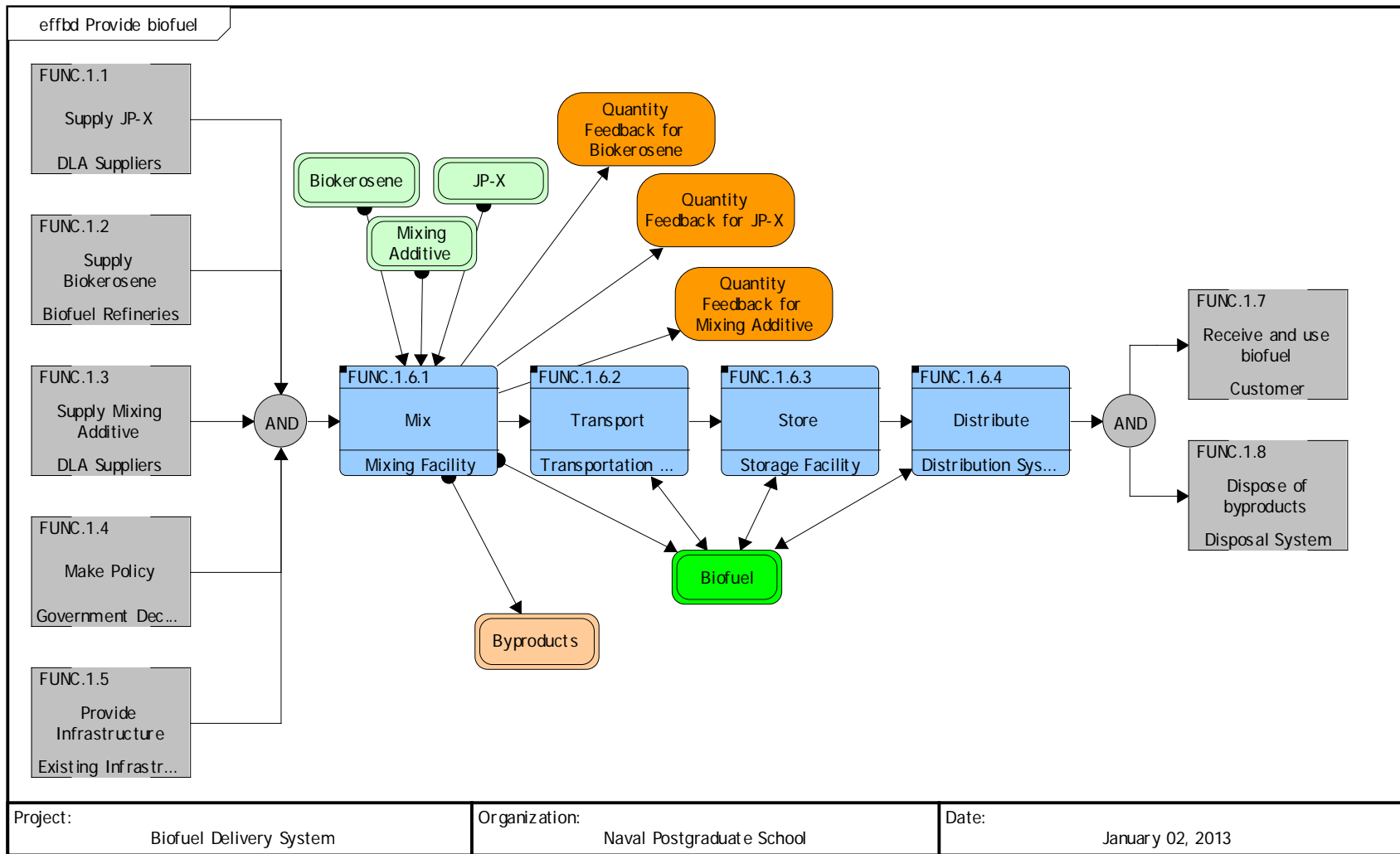

Figure 56. Provide biofuel (EFFBD)

## **FUNC.1.6.1 Mix**

Allocated To:

COMP.1.1.1 Mixing Facility

Specified By Requirements:

REQ.1.1.2 Mixing Requirement

Table 7 FUNC.1.6.1 Mix

<b>Interfacing Items</b>	<b>Source / Destination</b>
Quantity Feedback for Biokerosene	Triggers Function(s): FUNC.1.2 Supply Biokerosene Output From: FUNC.1.6 Provide biofuel FUNC.1.6.1 Mix FUNC.1.6.1.4 Store Biofuel post-mixing FUNC.1.6.1.4.2 Communicate storage status
Quantity Feedback for JP-X	Triggers Function(s): FUNC.1.1 Supply JP-X Output From: FUNC.1.6 Provide biofuel FUNC.1.6.1 Mix FUNC.1.6.1.4 Store Biofuel post-mixing FUNC.1.6.1.4.2 Communicate storage status
Quantity Feedback for Mixing Additive	Triggers Function(s): FUNC.1.3 Supply Mixing Additive Output From: FUNC.1.6 Provide biofuel FUNC.1.6.1 Mix FUNC.1.6.1.3 Mix elements FUNC.1.6.1.3.1 Prepare biokerosene for mixing FUNC.1.6.1.3.1.1 Mix biokerosene and mixing additive

Consumes Resource(s):

RESOURCE.2 JP-X

Acquire Available: true

RESOURCE.3 Biokerosene

Acquire Available: true

RESOURCE.4 Mixing Additive

Acquire Available: true

Produces Resource(s):

RESOURCE.1 Biofuel

Byproducts

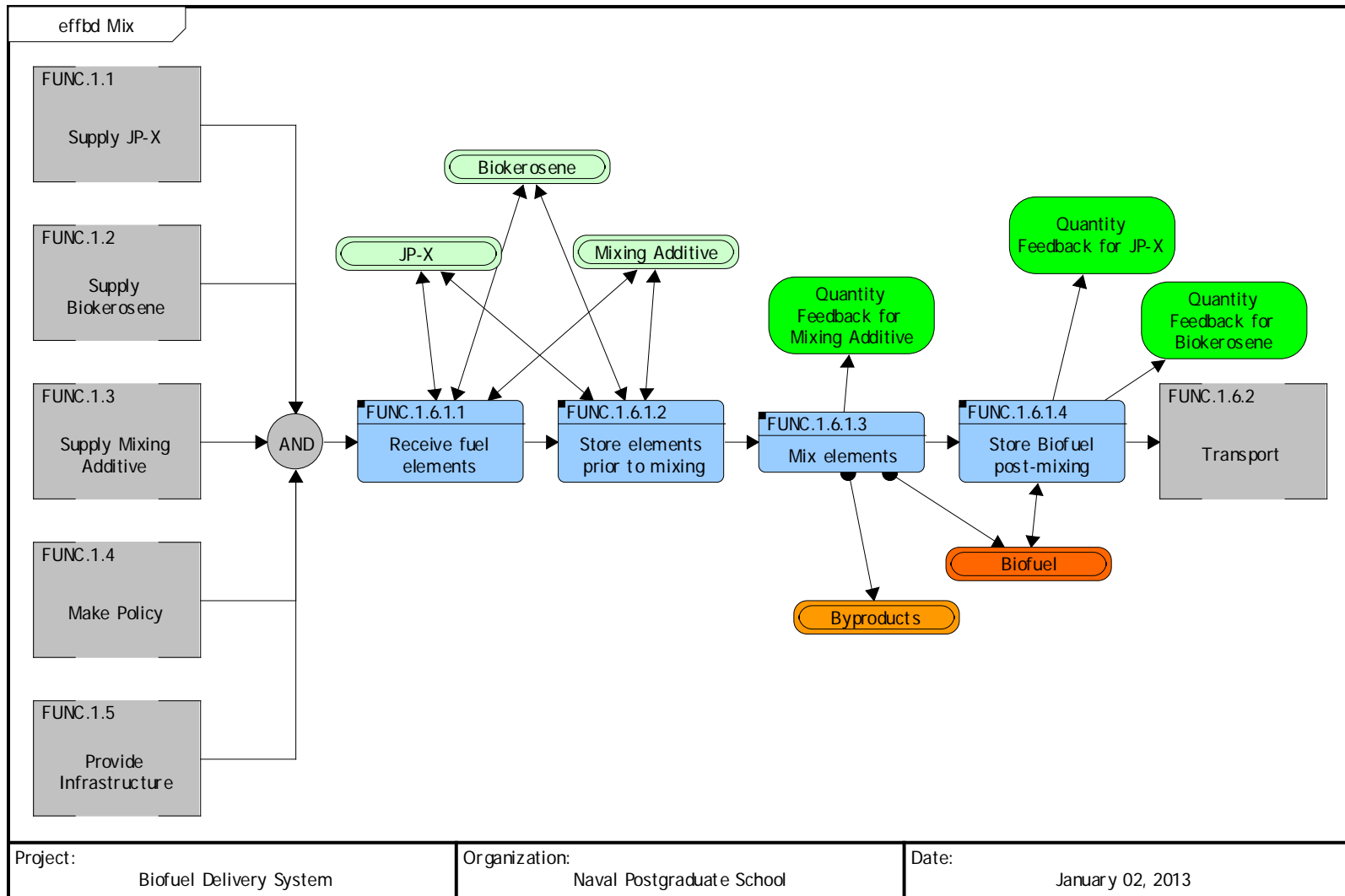

Figure 57. Mix (EFFBD)

### FUNC.1.6.1.1 Receive fuel elements

Allocated To:

- COMP.1.1.1.3 Biokerosene Pre-Mix Storage Tank
- COMP.1.1.1.4 JP-X Pre-Mix Storage Tank
- COMP.1.1.1.5 Mixing Additive Pre-Mix Storage Tank

Specified By Requirements:

- REQ.1.1.2 Mixing Requirement

Captures Resource(s):

RESOURCE.2 JP-X  
Acquire Available: true

RESOURCE.3 Biokerosene  
Acquire Available: true

RESOURCE.4 Mixing Additive  
Acquire Available: true

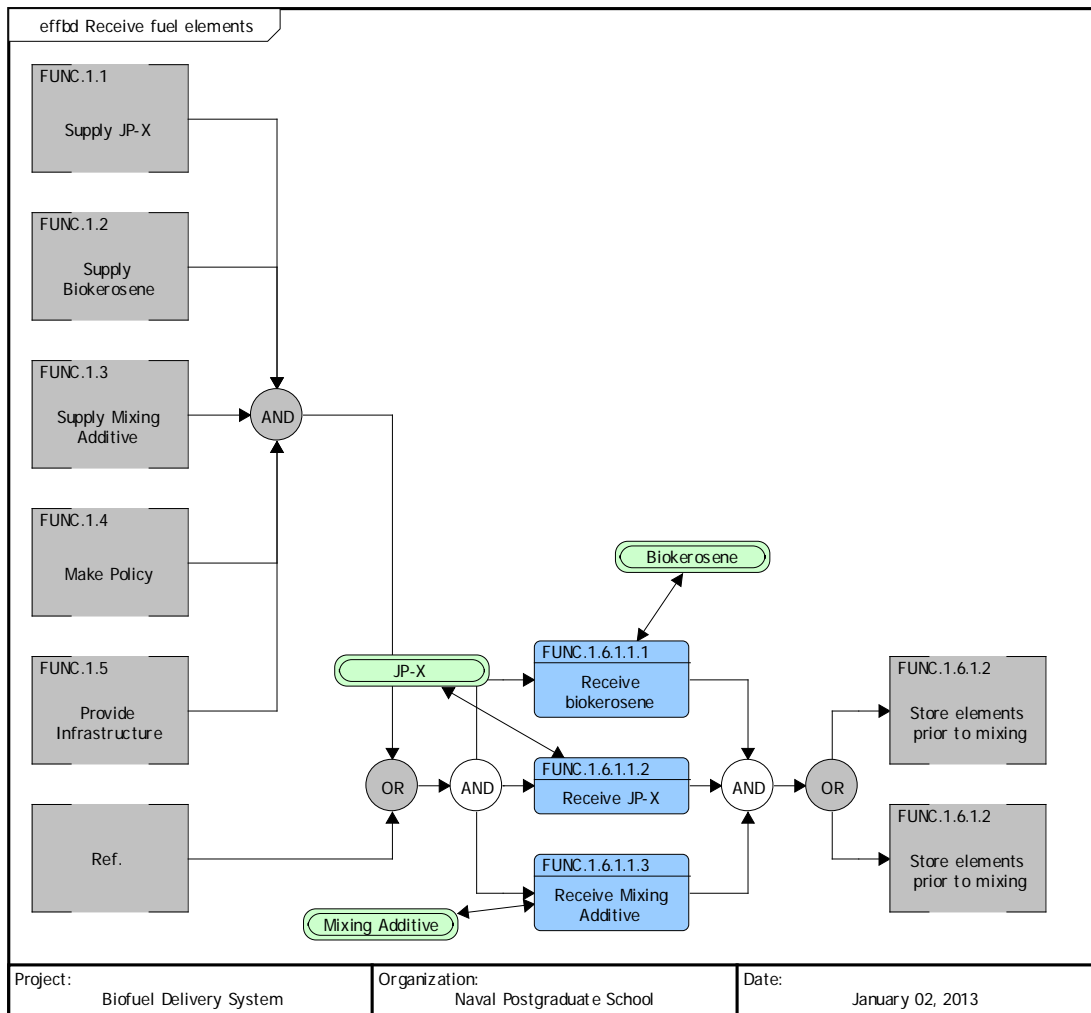

Figure 58. Receive Fuel Elements (EFFBD)

#### **FUNC.1.6.1.1.1 Receive biokerosene**

Allocated To:

COMP.1.1.1.2 Biokerosene Prep Tank

COMP.1.1.1.3 Biokerosene Pre-Mix Storage Tank

Specified By Requirements:

REQ.1.1.2 Mixing Requirement

Captures Resource(s):

RESOURCE.3 Biokerosene

Acquire Available: true

#### **FUNC.1.6.1.1.2 Receive JP-X**

Allocated To:

COMP.1.1.1 Mixing Facility

COMP.1.1.1.4 JP-X Pre-Mix Storage Tank

Specified By Requirements:

REQ.1.1.2 Mixing Requirement

Captures Resource(s):

RESOURCE.2 JP-X

Acquire Available: true

#### **FUNC.1.6.1.1.3 Receive Mixing Additive**

Allocated To:

COMP.1.1.1 Mixing Facility

COMP.1.1.1.5 Mixing Additive Pre-Mix Storage Tank

Captures Resource(s):

RESOURCE.4 Mixing Additive

Acquire Available: true

#### **FUNC.1.6.1.2 Store elements prior to mixing**

Allocated To:

COMP.1.1.1.2 Biokerosene Prep Tank

COMP.1.1.1.3 Biokerosene Pre-Mix Storage Tank

COMP.1.1.1.4 JP-X Pre-Mix Storage Tank

COMP.1.1.1.5 Mixing Additive Pre-Mix Storage Tank

Specified By Requirements:

REQ.1.1.2 Mixing Requirement

Captures Resource(s):

RESOURCE.2 JP-X

Acquire Available: true

RESOURCE.3 Biokerosene

Acquire Available: true

RESOURCE.4 Mixing Additive  
Acquire Available: true

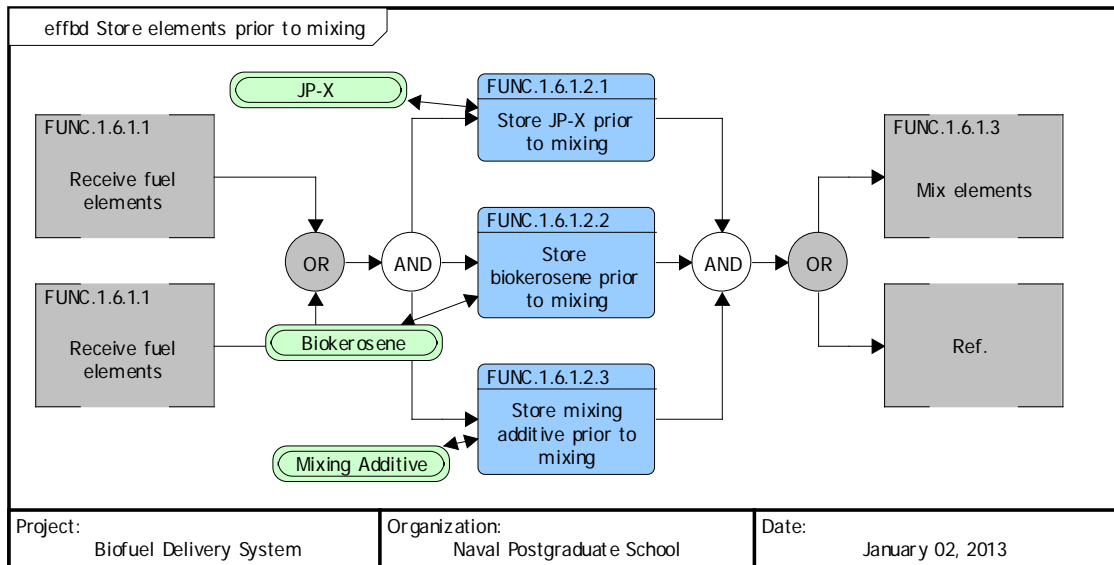

Figure 59. Store elements prior to mixing (EFFBD)

**FUNC.1.6.1.2.1 Store JP-X prior to mixing**

Allocated To:  
COMP.1.1.1 Mixing Facility  
COMP.1.1.1.4 JP-X Pre-Mix Storage Tank

Captures Resource(s):  
RESOURCE.2 JP-X  
Acquire Available: true

**FUNC.1.6.1.2.2 Store biokerosene prior to mixing**

Allocated To:  
COMP.1.1.1 Mixing Facility  
COMP.1.1.1.3 Biokerosene Pre-Mix Storage Tank

Captures Resource(s):  
RESOURCE.3 Biokerosene  
Acquire Available: true

**FUNC.1.6.1.2.3 Store mixing additive prior to mixing**

Allocated To:  
COMP.1.1.1 Mixing Facility  
COMP.1.1.1.5 Mixing Additive Pre-Mix Storage Tank

Captures Resource(s):  
RESOURCE.4 Mixing Additive

Acquire Available: true

**FUNC.1.6.1.3 Mix elements**

Allocated To:  
 COMP.1.1.1 Mixing Facility

Specified By Requirements:  
 REQ.1.1.2 Mixing Requirement  
 REQ.1.1.2.1 Mixing Requirement 01  
 REQ.1.1.2.2 Mixing Requirement 03

Table 8 FUNC.1.6.1.3 Mix Elements

Interfacing Items	Source / Destination
Quantity Feedback for Mixing Additive	Triggers Function(s): FUNC.1.3 Supply Mixing Additive Output From: FUNC.1.6 Provide biofuel FUNC.1.6.1 Mix FUNC.1.6.1.3 Mix elements FUNC.1.6.1.3.1 Prepare biokerosene for mixing FUNC.1.6.1.3.1.1 Mix biokerosene and mixing additive

Produces Resource(s):  
 RESOURCE.1 Biofuel  
 Byproducts

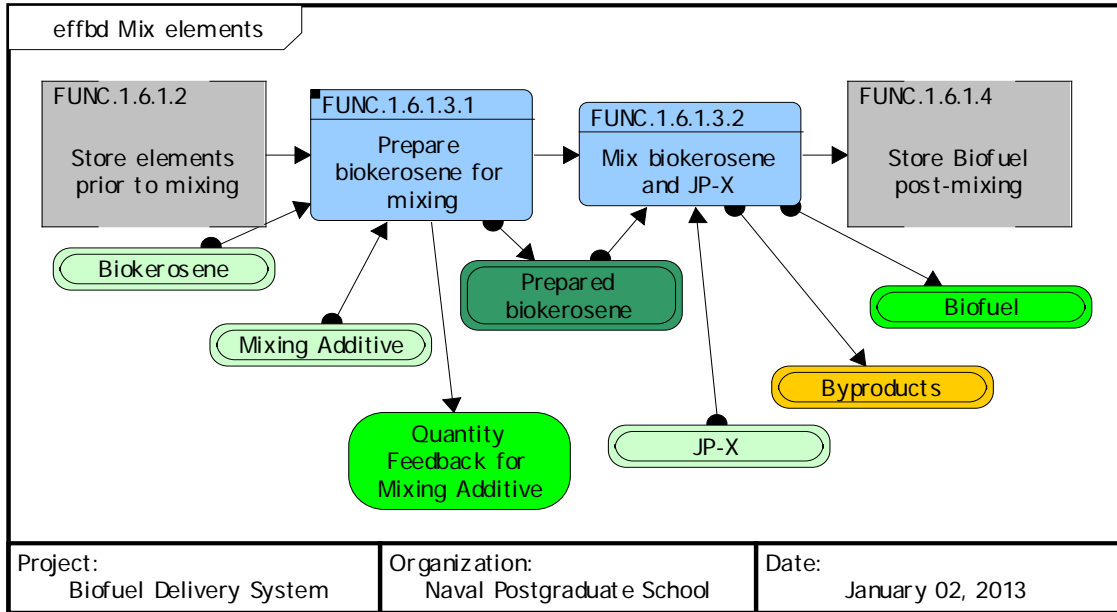

Figure 60. Mix elements (EFFBD)

### FUNC.1.6.1.3.1 Prepare biokerosene for mixing

Allocated To:  
COMP.1.1.1 Mixing Facility

Specified By Requirements:  
REQ.1.1.2.1 Mixing Requirement 01  
REQ.1.1.2.2 Mixing Requirement 03

Table 9 FUNC.1.6.1.3.1 Prepare Biokerosene for Mixing

Interfacing Items	Source / Destination
Quantity Feedback for Mixing Additive	Triggers Function(s): FUNC.1.3 Supply Mixing Additive Output From: FUNC.1.6 Provide biofuel FUNC.1.6.1 Mix FUNC.1.6.1.3 Mix elements FUNC.1.6.1.3.1 Prepare biokerosene for mixing FUNC.1.6.1.3.1.1 Mix biokerosene and mixing additive

Consumes Resource(s):  
RESOURCE.3 Biokerosene  
Acquire Available: true

RESOURCE.4 Mixing Additive  
Acquire Available: true

Produces Resource(s):  
RESOURCE.5 Prepared biokerosene

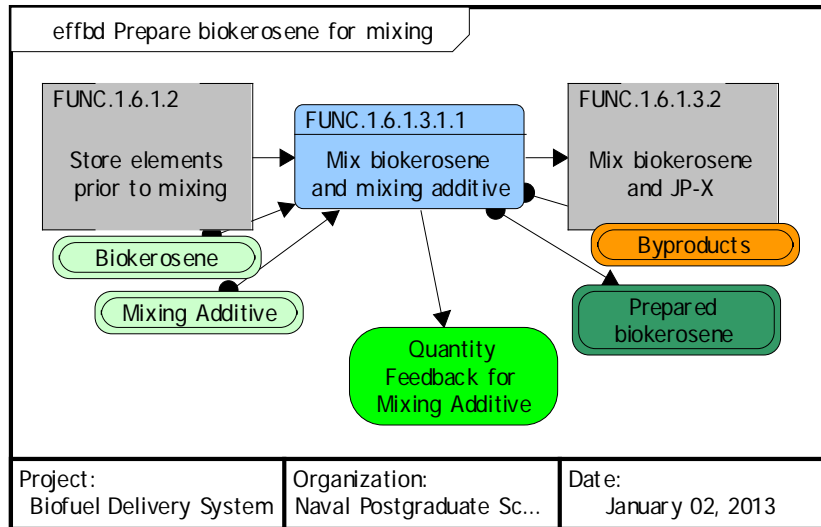

Figure 61. Prepare biokerosene for mixing (EFFBD)



### **FUNC.1.6.1.3.1.1 Mix Biokerosene and mixing additive**

Allocated To:

COMP.1.1.1 Mixing Facility

Specified By Requirements:

REQ.1.1.2.1 Mixing Requirement 01

REQ.1.1.2.2 Mixing Requirement 03

Table 10 FUNC.1.6.1.3.1.1 Mix Biokerosene and Mixing Additive

Interfacing Items	Source / Destination
Quantity Feedback for Mixing Additive	Triggers Function(s): FUNC.1.3 Supply Mixing Additive Output From: FUNC.1.6 Provide biofuel FUNC.1.6.1 Mix FUNC.1.6.1.3 Mix elements FUNC.1.6.1.3.1 Prepare biokerosene for mixing FUNC.1.6.1.3.1.1 Mix biokerosene and mixing additive

Consumes Resource(s):

RESOURCE.3 Biokerosene

Acquire Available: true

RESOURCE.4 Mixing Additive

Acquire Available: true

Produces Resource(s):

RESOURCE.5 Prepared biokerosene

Byproducts

### **FUNC.1.6.1.3.2 Mix biokerosene and JP-X**

Description:

Mixing of petroleum-based fuel and bio-based fuel. Results in 50/50 blend of mixed biofuel.

Allocated To:

COMP.1.1.1.1 Biofuel Mixing Tank

Specified By Requirements:

REQ.1.1.2.1 Mixing Requirement 01

REQ.1.1.2.2 Mixing Requirement 03

Consumes Resource(s):

RESOURCE.2 JP-X

Acquire Available: true

RESOURCE.5 Prepared biokerosene

Acquire Available: true

Produces Resource(s):

RESOURCE.1 Biofuel

Byproducts

### **FUNC.1.6.1.4 Store Biofuel post-mixing**

Allocated To:

COMP.1.1.1.6 Post-Mixing Storage Tank

Specified By Requirements:

REQ.1.1.2 Mixing Requirement

Table 11 FUN.1.6.1.4 Store Biofuel Post-Mixing

<b>Interfacing Items</b>	<b>Source / Destination</b>
Quantity Feedback for Biokerosene	Triggers Function(s): FUNC.1.2 Supply Biokerosene Output From: FUNC.1.6 Provide biofuel FUNC.1.6.1 Mix FUNC.1.6.1.4 Store Biofuel post-mixing FUNC.1.6.1.4.2 Communicate storage status
Quantity Feedback for JP-X	Triggers Function(s): FUNC.1.1 Supply JP-X Output From: FUNC.1.6 Provide biofuel FUNC.1.6.1 Mix FUNC.1.6.1.4 Store Biofuel post-mixing FUNC.1.6.1.4.2 Communicate storage status

Captures Resource(s):

RESOURCE.1 Biofuel

Acquire Available: true

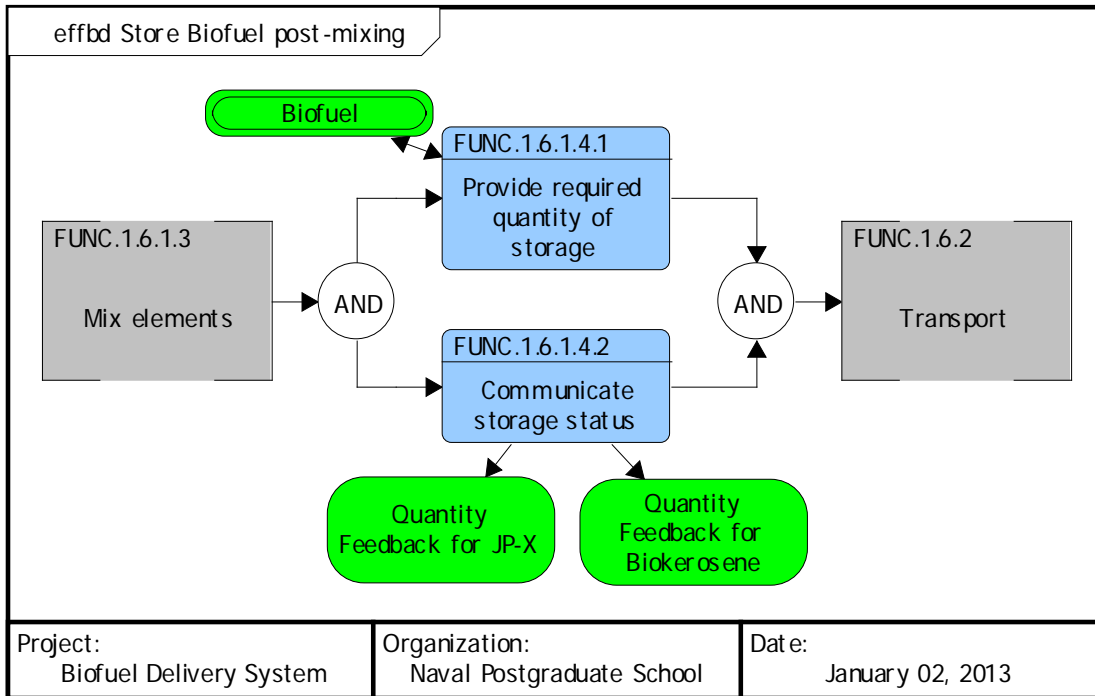

Figure 62. Store Biofuel post-mixing (EFFBD)

**FUNC.1.6.1.4.1 Provide required quantity of storage**

Allocated To:  
COMP.1.1.1 Mixing Facility

Captures Resource(s):  
RESOURCE.1 Biofuel  
Acquire Available: true

**FUNC.1.6.1.4.2 Communicate storage status**

Allocated To:  
COMP.1.1.1 Mixing Facility

Table 12 FUNC.1.6.1.4.2 Communicate Storage Status

Interfacing Items	Source / Destination
Quantity Feedback for Biokerosene	Triggers Function(s): FUNC.1.2 Supply Biokerosene Output From: FUNC.1.6 Provide biofuel FUNC.1.6.1 Mix FUNC.1.6.1.4 Store Biofuel post-mixing FUNC.1.6.1.4.2 Communicate storage status
Quantity Feedback for JP-X	Triggers Function(s): FUNC.1.1 Supply JP-X Output From: FUNC.1.6 Provide biofuel FUNC.1.6.1 Mix FUNC.1.6.1.4 Store Biofuel post-mixing FUNC.1.6.1.4.2 Communicate storage status

### **FUNC.1.6.2 Transport**

Allocated To:

COMP.1.1.4 Transportation System

Specified By Requirements:

REQ.1.1.4 Transportation Requirement

Captures Resource(s):

RESOURCE.1 Biofuel

Acquire Available: true

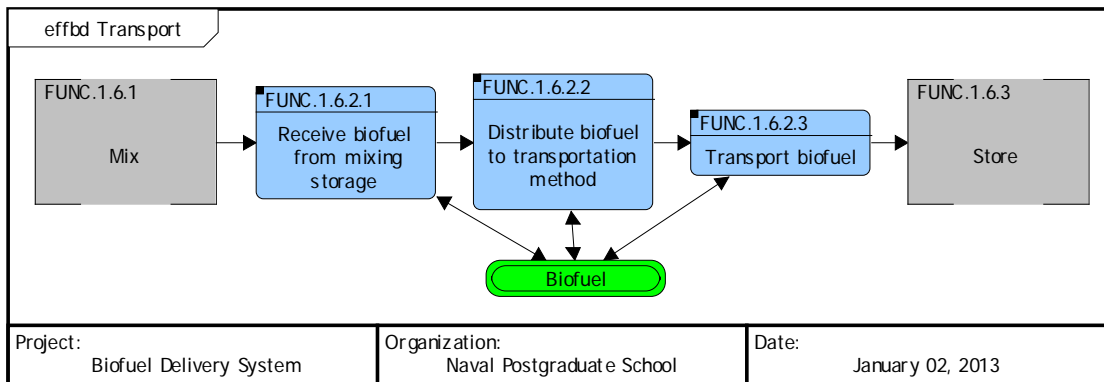

Figure 63. Transport (EFFBD)

### **FUNC.1.6.2.1 Receive biofuel from mixing storage**

Allocated To:

COMP.1.1.4 Transportation System

Specified By Requirements:  
REQ.1.1.4 Transportation Requirement

Captures Resource(s):  
RESOURCE.1 Biofuel  
Acquire Available: true

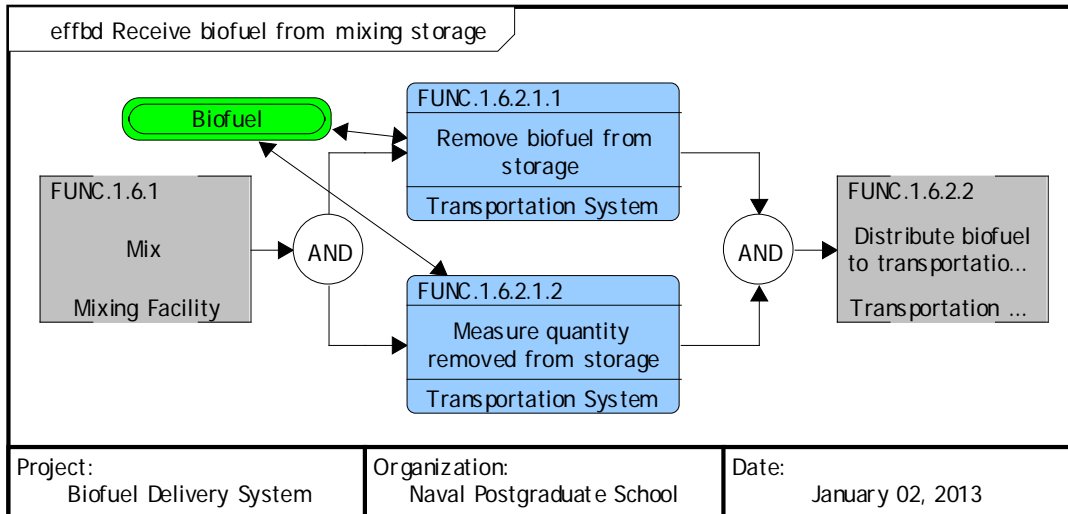

Figure 64. Receive biofuel from mixing storage (EFFBD)

### **FUNC.1.6.2.1.1 Remove biofuel from storage**

Allocated To:  
COMP.1.1.4 Transportation System

Specified By Requirements:  
REQ.1.1.4 Transportation Requirement

Captures Resource(s):  
RESOURCE.1 Biofuel  
Acquire Available: true

### **FUNC.1.6.2.1.2 Measure quantity removed from storage**

Allocated To:  
COMP.1.1.4 Transportation System

Specified By Requirements:  
REQ.1.1.4 Transportation Requirement

Captures Resource(s):  
RESOURCE.1 Biofuel  
Acquire Available: true

## FUNC.1.6.2.2 Distribute biofuel to transportation method

Allocated To:

COMP.1.1.4 Transportation System

COMP.1.1.4.1 Transportation Loading Facility

Specified By Requirements:

REQ.1.1.4 Transportation Requirement

Captures Resource(s):

RESOURCE.1 Biofuel

Acquire Available: true

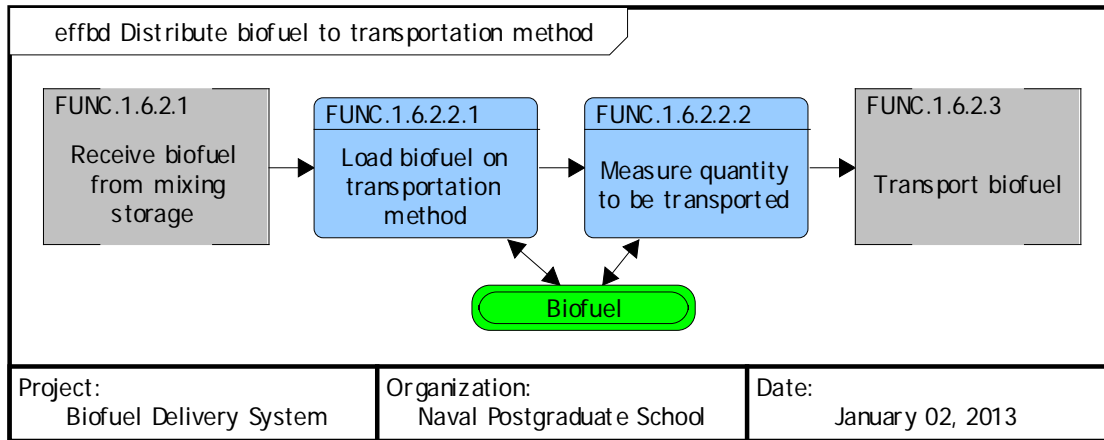

Figure 65. Distribute biofuel to transportation method (EFFBD)

### FUNC.1.6.2.2.1 Load biofuel on transportation method

Allocated To:

COMP.1.1.4 Transportation System

COMP.1.1.4.1 Transportation Loading Facility

Specified By Requirements:

REQ.1.1.4 Transportation Requirement

Captures Resource(s):

RESOURCE.1 Biofuel

Acquire Available: true

### FUNC.1.6.2.2.2 Measure quantity to be transported

Allocated To:

COMP.1.1.4 Transportation System

Specified By Requirements:

REQ.1.1.4 Transportation Requirement

Captures Resource(s):

RESOURCE.1 Biofuel

Acquire Available: true

### FUNC.1.6.2.3 Transport biofuel

Allocated To:

- COMP.1.1.4 Transportation System
- COMP.1.1.4.2 Transportation Method

Specified By Requirements:

- REQ.1.1.4 Transportation Requirement

Captures Resource(s):

- RESOURCE.1 Biofuel
- Acquire Available: true

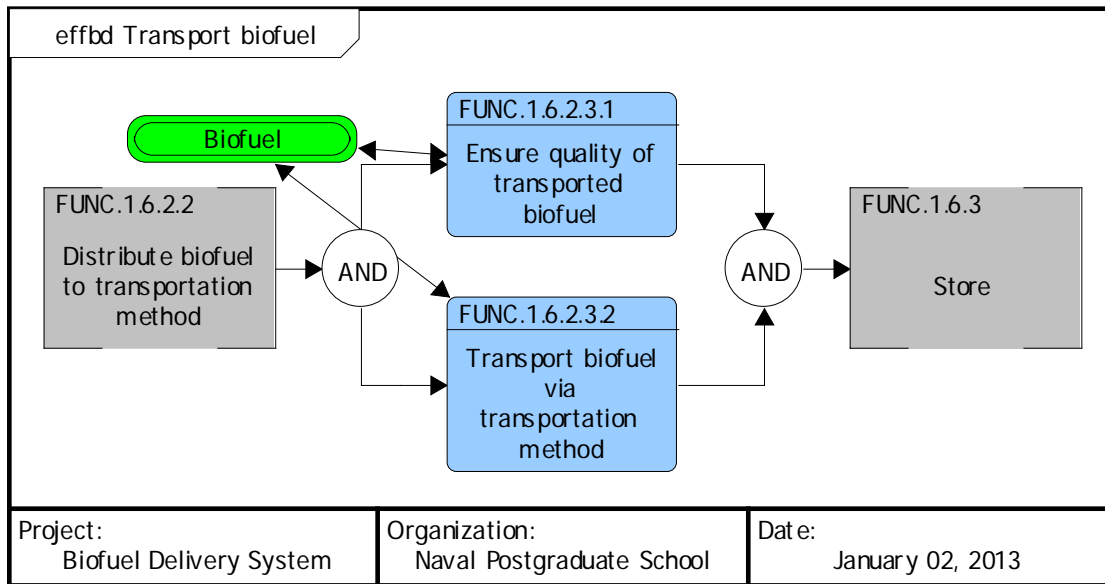

Figure 66. Transport biofuel (EFFBD)

#### FUNC.1.6.2.3.1 Ensure quality of transported biofuel

Specified By Requirements:

- REQ.1.1.4 Transportation Requirement

Captures Resource(s):

- RESOURCE.1 Biofuel
- Acquire Available: true

#### FUNC.1.6.2.3.2 Transport biofuel via transportation method

Allocated To:

- COMP.1.1.4 Transportation System
- COMP.1.1.4.2 Transportation Method

Specified By Requirements:

- REQ.1.1.4 Transportation Requirement

Captures Resource(s):  
 RESOURCE.1 Biofuel  
 Acquire Available: true

### **FUNC.1.6.3 Store**

Allocated To:  
 COMP.1.1.3 Storage Facility

Specified By Requirements:  
 REQ.1.1.3 Storage Requirement

Captures Resource(s):  
 RESOURCE.1 Biofuel  
 Acquire Available: true

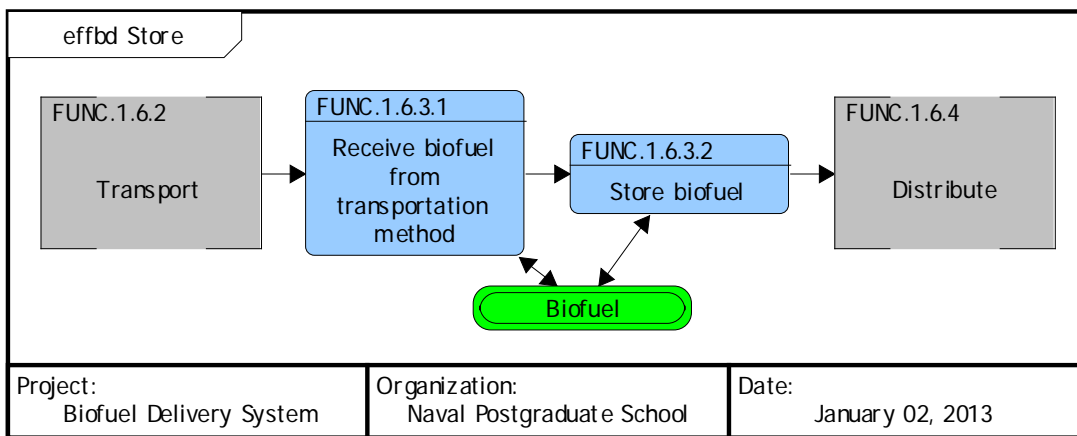

Figure 67. Store (EFFBD)

### **FUNC.1.6.3.1 Receive biofuel from transportation method**

Allocated To:  
 COMP.1.1.3.2 Storage Tank Interface  
 COMP.1.1.4.3 Transportation Unloading Facility

Specified By Requirements:  
 REQ.1.1.3 Storage Requirement

Captures Resource(s):  
 RESOURCE.1 Biofuel  
 Acquire Available: true

### **FUNC.1.6.3.2 Store biofuel**

Allocated To:  
 COMP.1.1.3.1 Storage Tank

Specified By Requirements:  
 REQ.1.1.3 Storage Requirement



Captures Resource(s):  
 RESOURCE.1 Biofuel  
 Acquire Available: true

### **FUNC.1.6.4 Distribute**

Allocated To:  
 COMP.1.1.2 Distribution System

Specified By Requirements:  
 REQ.1.1.1 Distribution Requirement

Captures Resource(s):  
 RESOURCE.1 Biofuel  
 Acquire Available: true

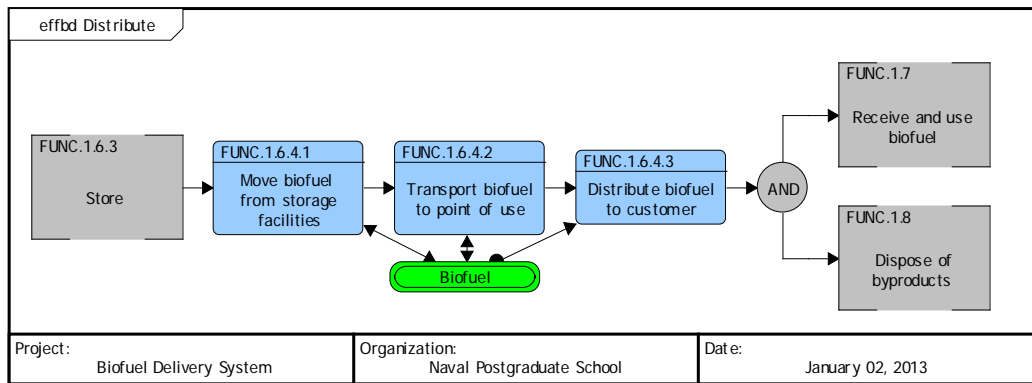

Figure 68. Distribute (EFFBD)

### **FUNC.1.6.4.1 Move biofuel from storage facilities**

Allocated To:  
 COMP.1.1.2.2 Loading Facility

Specified By Requirements:  
 REQ.1.1.1 Distribution Requirement

Captures Resource(s):  
 RESOURCE.1 Biofuel  
 Acquire Available: true

### **FUNC.1.6.4.2 Transport biofuel to point of use**

Allocated To:  
 COMP.1.1.2.1 Distribution Method

Specified By Requirements:  
 REQ.1.1.1 Distribution Requirement

Captures Resource(s):  
 RESOURCE.1 Biofuel  
 Acquire Available: true

### **FUNC.1.6.4.3 Distribute biofuel to customer**

Allocated To:

COMP.1.1.2 Distribution System

COMP.1.1.2.2 Loading Facility

Specified By Requirements:

REQ.1.1.1 Distribution Requirement

Consumes Resource(s):

RESOURCE.1 Biofuel

Acquire Available: true

### **FUNC.1.7 Receive and use biofuel**

Allocated To:

COMP.1.2 Customer

Table 13 FUNC.1.7 Receive and Use Biofuel

<b>Interfacing Items</b>	<b>Source / Destination</b>
Customer Feedback	Triggers Function(s): FUNC.1.6 Provide biofuel Output From: FUNC.1.7 Receive and use biofuel

Captures Resource(s):

RESOURCE.1 Biofuel

Acquire Available: true

### **FUNC.1.8 Dispose of byproducts**

Allocated To:

COMP.1.3 Disposal System

Consumes Resource(s):

Byproducts

Acquire Available: true

THIS PAGE INTENTIONALLY LEFT BLANK

## **APPENDIX C: VALUE MODELING PROCESS**

This Appendix will discuss the details of our Value Modeling process. Specifically, it will address how the stakeholder input was analyzed and used to create our HOQ matrices to determine the weights of our specified functions.

All requirements were clearly defined below the Pairwise Comparison sent to stakeholders. The definitions of the requirements are as follows:

### **A. CAPABILITY**

The algae based biofuel distribution system is required to transport, store, and distribute up to 25% of the DODs jet fuel consumption within the state of Hawaii in a cost-effective manner. Composed of four sub-functions:

### **B. DISTRIBUTION**

The system will distribute a 50/50 mix of bio-based and petroleum based JP-X from the mixing point to the point of use. The focus of this capstone is on distributing the 50/50 mix from a mixing facility on Oahu to Joint Base Pearl Harbor-Hickam and Marine Corps Base Kaneohe Bay, Hawaii.

### **C. MIXING**

The BDS shall be capable of mixing bio-kerosene, equivalent of Jet A-1 fuel, with the appropriate additives to create a bio-based version of JP-5 and JP-8 fuels in accordance with MIL-DTL-55642 and MIL-DTL-83133, respectively. The bio JP-X will then be mixed with the equivalent petroleum-based JP-X to form a 50/50 bio/petroleum mixture for use in PACOM aircraft.

### **D. STORAGE**

The BDS shall be capable of storing all required elements of the final 50/50 product prior to mixing. These products include additives, bio-kerosene, and petroleum based JP-X. The BDS shall be capable of storing the final 50/50 mixture while awaiting transportation off site. The BDS shall provide for any necessary storage at the end user's

facilities prior to final transportation to the aircraft. The final storage volume requirements will be determined based on the average expected usage and average daily production rates.

#### **E. TRANSPORTATION**

The BDS shall be capable of transporting the 50/50 JP-X from the mixing location to the point of use. The transportation system shall consist of any combination of land and sea routes that comply with federal and local ordinances.

#### **F. CONSTRAINING**

The distribution system must be built within a set budget and provide full operational capability by 2020.

#### **G. ENVIRONMENTAL COMPLIANCE**

The BDS must comply with all applicable federal, state, and local laws governing the production, storage, handling, and transportation of fuel products.

#### **H. INTEROPERABILITY**

The BDS must be interoperable with the existing infrastructure in Hawaii. Where practical, existing fuel distribution networks will be utilized to the greatest extent possible to minimize the necessity for the addition of new equipment. New pipelines constructed to transport the biofuel will be designated to transport multiple fuel products and incorporate means to physically separate the various fuels during transport (pipeline pigs).

#### **I. MAINTAINABILITY**

The distribution must be designed to minimize the maintenance costs over the expected service life of 50 years. The BDS shall be designed to minimize maintenance times and labor hours while maximizing supportability characteristics by providing automated diagnostic systems, ensuring that typical maintenance items are easily accessible, and using industry-standard components. Maintenance actions will be

supported through a range of logistic resources, including spares, test equipment, personnel, and facilities.

#### **J. PRODUCIBILITY**

The BDS will be designed to minimize the need for exotic manufacturing processes. To minimize production costs, where feasible, the final design will be producible using standard manufacturing processes, standard tools, and existing equipment. To facilitate rapid and economical disassembly and disposal, the design will minimize the use of hazardous materials both in the product as well as the manufacturing process.

#### **K. RELIABILITY**

The BDS will be an integral part of PACOMs fuel supply system in Hawaii and as such, its design must maximize operational reliability while minimizing system failure (B&F).

#### **L. SECURITY**

The BDS will be a vital component to PACOMs fuel distribution system, and as such, is expected to be a key target in any conventional conflict and has the potential to be targeted by terrorists trying to inflict damage on vital U.S. DoD infrastructure. The biofuel distribution system design will incorporate necessary security measures, such as cameras and perimeter sensors, to ensure the security and continued operation of the fuel distribution system.

#### **M. SERVICE LIFE**

The BDS is expected to service PACOM for a minimum of 50 years.

#### **N. SUPPORTABILITY**

Human Factors Engineering, Reliability Analyses, and Maintenance Task Analyses will be conducted to ensure that the BDS design meets all support and service requirements throughout its lifetime.

**O. SUSTAINABILITY**

The BDS system shall be constructed in an environmentally conscious manner to protect the fragile Hawaiian ecosystem. Care shall be taken to minimize the impacts of constructing new facilities. Where feasible, renewable energy sources shall be used to power new infrastructure.

**P. USABILITY AND SAFETY**

Human Factors Engineering (HFE) was applied during the design phase of the BDS to ensure compatibility between the system and the human operators and maintainers. The application of HFE has ensured that adequate manpower and personnel were identified to operate and maintain the various fuel distribution components. A value key was also used to provide interpretation of the values of specific numbers. The numbers 1, 3, and 9 were described to mean “Of equal value,” “Moderately more important,” and “Strongly more important,” respectively. PACOM was given the instructions to highlight the numbered cell that corresponds with their organization’s value of each requirement. The following two examples were provided for instructional use:

‘If your organization believes that the *capability* requirement is *moderately more important* than the *constraining* requirement, the value for ‘Moderately more important’ (3) closest to ‘Capability’ should be highlighted, as shown below:

Top Level System Requirements																		
<b>Capability</b>	9	8	7	6	5	4	3	2	1	2	3	4	5	6	7	8	9	<b>Constraining</b>

Table 21. 1<sup>st</sup> Example of the Top Level System Requirements Pairwise Comparison - Single Row

However, if your company instead believes that the *constraining* requirement is *strongly more important* than the *capability* requirement, the value for ‘Strongly more important’ (9) closest to ‘Constraining’ should be highlighted, as shown below:’

Top Level System Requirements																		
<b>Capability</b>	9	8	7	6	5	4	3	2	1	2	3	4	5	6	7	8	9	<b>Constraining</b>

Table 22. 2<sup>nd</sup> Example of the Top Level System Requirements Pairwise Comparison - Single Row

The results of the Top Level pairwise comparison from PACOM is shown below. The categories highlighted in the far right column point to the three that are ranked the highest in importance, which are ‘Environmental,’ ‘Sustainability,’ and ‘Constraining.’

	Top Level System Requirements																	
Capability	9	8	7	6	5	4	3	2	1	2	3	4	5	6	7	8	9	<b>Constraining</b>
Capability	9	8	7	6	5	4	3	2	1	2	3	4	5	6	7	8	9	<b>Environmental</b>
Capability	9	8	7	6	5	4	3	2	1	2	3	4	5	6	7	8	9	Interoperability
Capability	9	8	7	6	5	4	3	2	1	2	3	4	5	6	7	8	9	Maintainability
Capability	9	8	7	6	5	4	3	2	1	2	3	4	5	6	7	8	9	Producibility
Capability	9	8	7	6	5	4	3	2	1	2	3	4	5	6	7	8	9	Reliability
Capability	9	8	7	6	5	4	3	2	1	2	3	4	5	6	7	8	9	Security
Capability	9	8	7	6	5	4	3	2	1	2	3	4	5	6	7	8	9	Service Life
Capability	9	8	7	6	5	4	3	2	1	2	3	4	5	6	7	8	9	Supportability
Capability	9	8	7	6	5	4	3	2	1	2	3	4	5	6	7	8	9	<b>Sustainability</b>
Capability	9	8	7	6	5	4	3	2	1	2	3	4	5	6	7	8	9	Usability and Safety

Table 23. Results of PACOM Top Level System Requirements Pairwise Comparison

Similar to Table 23, our team also presented PACOM with an additional pairwise comparison table that showed the capability requirement broken down into sub-requirements. The purpose of this pairwise comparison was to discern our stakeholder’s value of the distribution sub-requirement against each of the other three sub-requirements that the capability requirement must fulfill. This type of comparison ensured a



standardized method of measurement of the distribution sub-requirement against every other sub-requirement. The distribution sub-requirement was chosen by our team as the variable that would be compared to the other sub-requirements because of its critical nature to the success of the Biofuel Distribution System.

Again, each of the sub-requirements was clearly defined beneath the table. The same Value Key as before was to be used in the completion of this table comparison as well. This time, however, a different instructional example was provided for additional interpretation of the numbering scheme, and that example was:

‘If your organization believes that the *distribution* sub-requirement is *equally as important as* the *mixing* sub-requirement, the value for ‘Equal in importance’ (1) should be highlighted, as shown below:’

Sub-Level Capability Requirements																		
<b>Distribution</b>	9	8	7	6	5	4	3	2	1	2	3	4	5	6	7	8	9	<b>Mixing</b>

Table 24. Example of the Sub-Level Capability Requirements Pairwise Comparison - Single Row

The results of the Sub Level Capability pairwise comparison from PACOM is shown below. The category highlighted in the far right column points to the one that ranks the highest in importance, which is ‘Transportation.’

	Sub-Level Capability Requirements																	
Distribution	9	8	7	6	5	4	3	2	1	2	3	4	5	6	7	8	9	Mixing
Distribution	9	8	7	6	5	4	3	2	1	2	3	4	5	6	7	8	9	Storage
Distribution	9	8	7	6	5	4	3	2	1	2	3	4	5	6	7	8	9	Transportation

Table 25. Results of PACOM Sub Level Capability Requirements Pairwise Comparison

Once we received the results of our pairwise comparisons from our primary stakeholder, we were able to analyze the results and develop a QFD of our system.

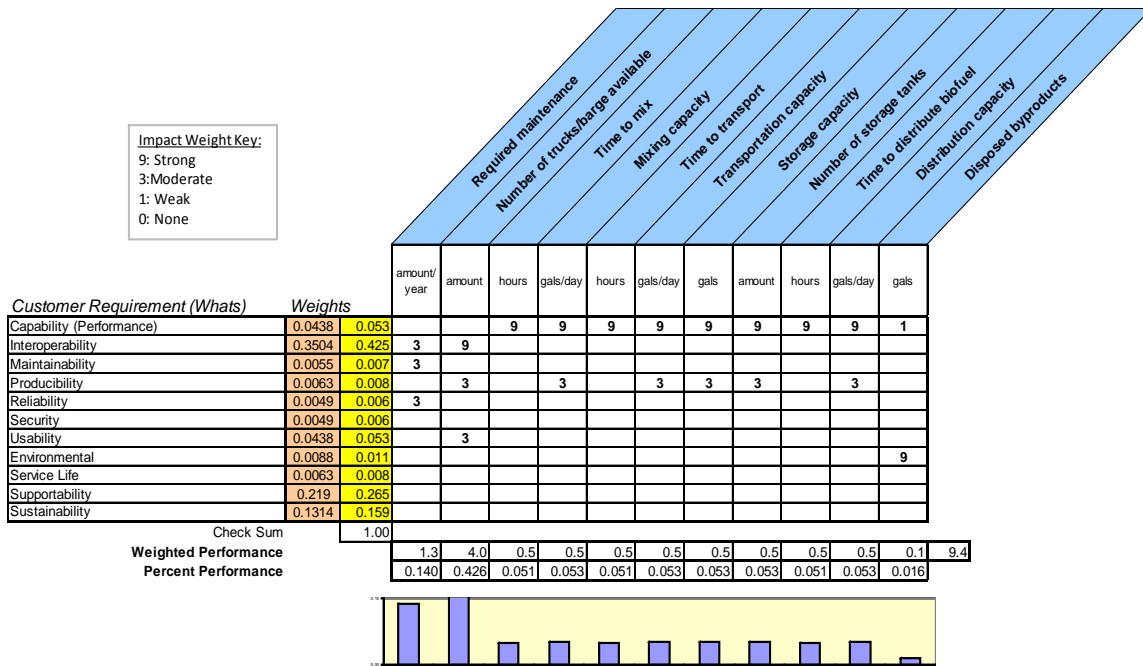

Figure 69. Matrix 1 - Comparing High-Level Req to Tech Characteristics (KPP)

This first matrix, Matrix 1, maps the high level requirements to system technical characteristics. The impact weight key is on a scale from nine to one and translates verbal impact statements to a numerical value that can be better utilized in value comparisons. These weights were taken from the AHP results returned from our primary stakeholder. The relative importance of the technical characteristics is displayed in the bar chart below the matrix. Additionally, the QFD matrices outline the evaluation measures for each KPP. Table 26 shows the unit of measure that is will be used to track the performance of these technical characteristics.

Key Performance Parameter	Unit of Measure
Time to Transport	Hours
Transportation Capacity	Gallons Per Day
Storage Capacity	Gallons
Time to Distribute Biofuel	Hours
Total Distributed Biofuel	Gallons Per Year

Table 26. KPPs and Associated Units of Measure

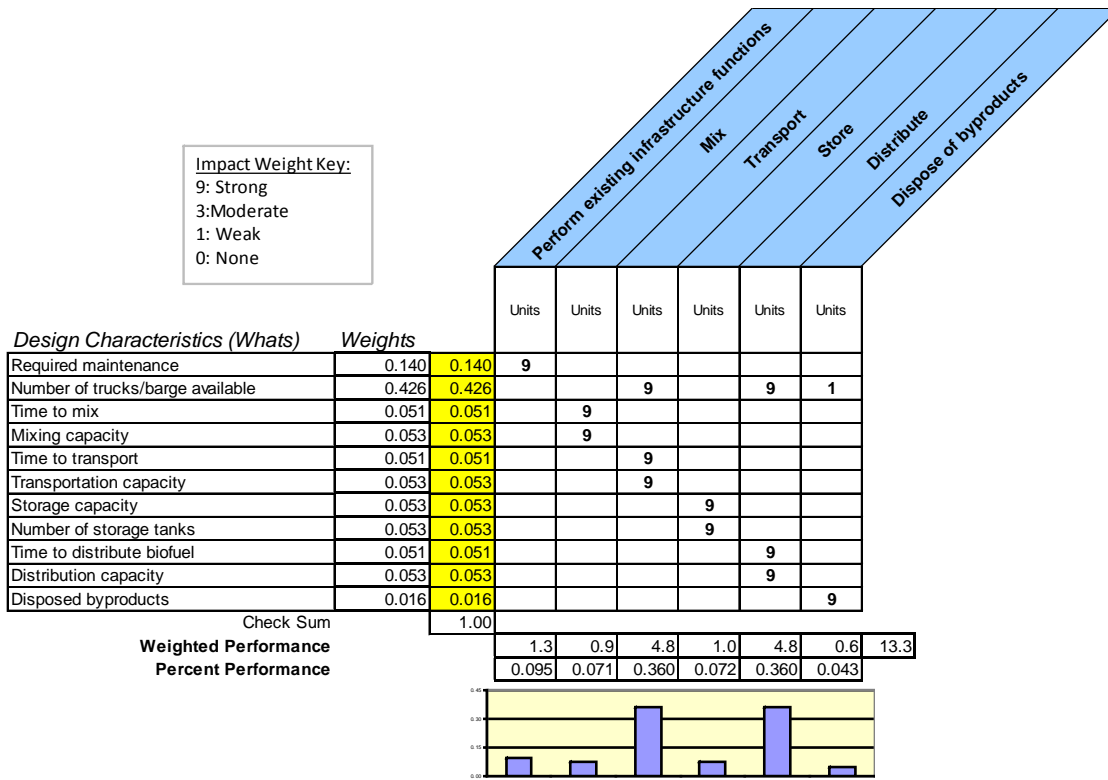

Figure 70. Matrix 2 - Comparing the Technical Characteristics to Functions

Figure 70 shows a second comparison matrix, Matrix 2. In this matrix we compared the technical characteristics of the first matrix to the top-level system functions. The same weighting method was used as in Matrix 1, whereupon verbal assessments of impact were converted to a nine to one scale. From the relative importance bar chart at the bottom one can see that the functions Transport and Distribute are the most important to stakeholders.

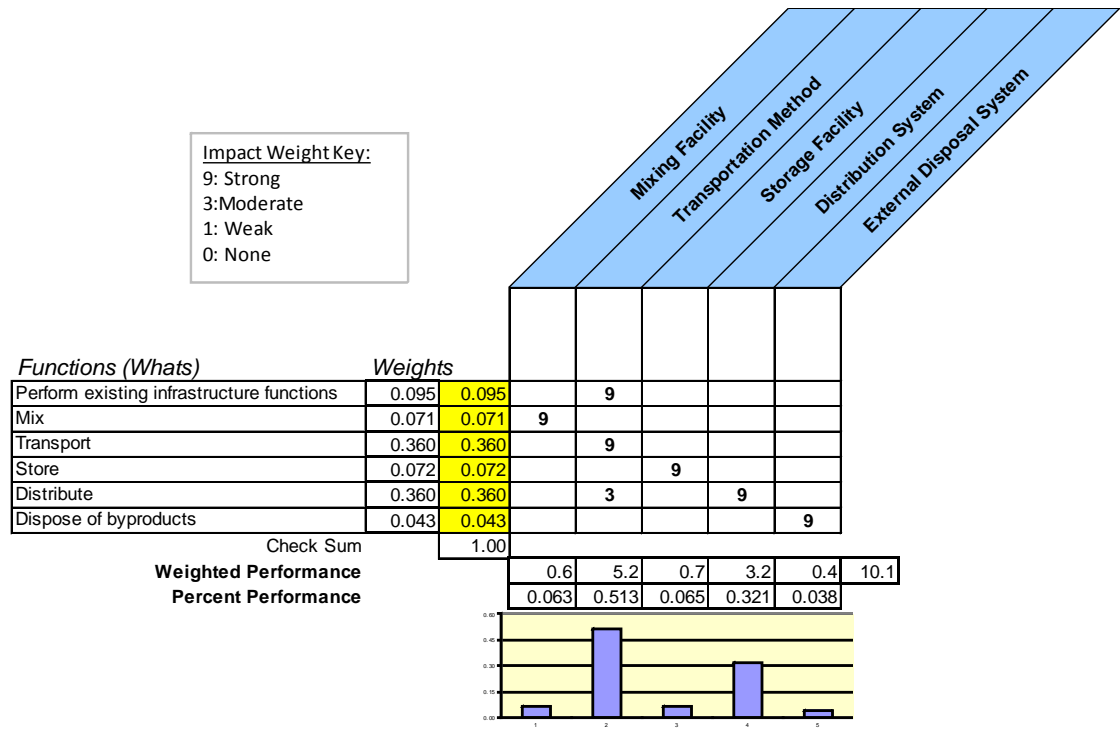

Figure 71. Matrix 3 - Maps Functions to Form

Our final matrix, Matrix 3, maps the functions of the system to the form. The physical components for this system are notional components that represent the basic physical components of the system. The chart at the bottom of the matrix shows that transportation is appropriately the most important component of the system as defined by stakeholder input. With these three matrices, the HOQ is complete and the design decisions can be traced directly back to system requirements.

THIS PAGE INTENTIONALLY LEFT BLANK

## APPENDIX D: COST

This appendix presents the data used to calculate costs for transporting the biofuel to JBPHH, MCBH, and Wheeler.

	Location			
	<b>JBPHH</b>	<b>MCBH</b>	<b>Wheeler</b>	
Cost per Truck-Mile	\$2.50	\$2.50	\$2.50	
Round trip Distance from Tesoro (miles)	40	68	32	
Trip cost (\$2.5x # of miles)	\$100.00	\$170.00	\$80.00	
Annual Req. Trips 5,000 gal Tank	7460	1000	120	
Annual Req. Trips 6,500 gal Tank	5738	769	92	
Annual Req. Trips 8,000 gal Tank	4663	625	75	<b>Total Annual Costs by Capacities</b>
Annual Costs 5,000 gal Tank	\$746,000	\$170,000	\$9,600	\$925,600
Annual Costs 6,500 gal Tank	\$573,846	\$130,769	\$7,385	\$712,000
Annual Costs 8,000 gal Tank	\$466,250	\$106,250	\$6,000	\$578,500

Table 27. Trucking Transportation Annual Costs by Mile

	Location			
	<b>JBP HH</b>	<b>MCBH</b>	<b>Wheeler</b>	
Cost per gal	\$0.12	\$0.12	\$0.12	
Delivered Quantity (gal)	37,300,000	5,000,000	600,000	<b>Total Annual Costs by Capacities</b>
Trip cost	\$4,476,000	\$600,000	\$72,000	\$5,148,000

Table 28. Trucking Transportation Annual Costs by Volume

	Location			
	<b>JBP HH</b>	<b>MCBH</b>	<b>Wheeler</b>	
Cost pipeline per gallon	\$0.06	\$0.06	\$0.06	
Amount Piped to Red Hill	37,300,000	5,000,000	600,000	
Piped cost to Red Hill	\$2,238,000	\$300,000	\$36,000	
Trucking Cost (\$0.12 /gal)	-	\$600,000	\$72,000	<b>Total Annual Costs by Volume</b>
Total Cost	\$2,238,000	\$900,000	\$108,000	\$3,246,000

Table 29. Combined Alternative Annual Costs by Volume

## **APPENDIX E: PROJECT MANAGEMENT PLAN (PMP)**

This Project Management Plan (PMP) lays out the approach of the Naval Postgraduate School (NPS) Cohort 311-1130 to the capstone project. The United States Department of Navy has expressed a need for a means to offset 25 percent of its annual aviation fuel usage with locally produced algae-based biofuels. The capstone project team will work to address the transportation, distribution, mixing, and storage needs for this new fuel by engaging with the appropriate stakeholders, conducting a requirements analysis, and formulating a feasible solution.

Specifically, the PMP describes the problem, the working group tasks with deliverables, the constraints, and the objectives of the project. It identifies the various stakeholders, including this team, the advisors, and the customer. The PMP then describes the bounded project problem statement and the team's Systems Engineering (SE) strategy. This SE strategy forms the framework of the proposed analysis approach, including tools, needs analysis, value system design, requirements analysis, architecture, modeling / simulation strategy, alternatives analysis, tradeoffs, alternative evaluation strategy, risk analysis, and risk mitigation strategy. In addition, the PMP also presents the project schedule with major milestones.





Algae-Based Biofuel Distribution Systems to Service  
the  
Department of Navy in Hawaii

## Project Management Plan

NAVAL POSTGRADUATE SCHOOL  
MONTEREY, CA  
MSSE – Systems Engineering

Team Biofuels  
Cohort 311-113Open



Distribution Statement: Approved for public release; distribution is unlimited.

Prepared for: Naval Postgraduate School, Monterey, CA 93943.

THIS PAGE INTENTIONALLY LEFT BLANK

**SUBMITTED BY  
NPS MSSE COHORT 311-113OPEN**

Kristen Kerns: Capstone Co-lead  
Richard Seriani: Capstone Co-lead  
Roge Adversalo  
Larry Coleman  
David Featherby  
Jon Hopkins  
Patrick Knowles  
John Lester  
Michael Lisella  
Kevin Neaves  
Joseph Villucci  
Annmarie Young

**SIGNATURE PAGE**

Submitted by:

  
Kristen Kerns LT, USN  
NPS MSSE Cohort 311-1130 Technical Lead  
SI 0810 Capstone Project

  
Richard Seriani  
NPS MSSE Cohort 311-1130 Administrative Lead  
SI 0810 Capstone Project

Reviewed by:

**KWINN.BRIGITTE.TW**  
**YLA.1145833007**  
Digitally signed by  
BRIGITTE TWINN, DN: cn=BRIGITTE TWINN, o=NPS, ou=USN, email=brigitte.twinn@nps.gov, c=US, Date: 2012.08.30 12:01:28 -0700

**Brigitte T. Kwinn**  
**MSSE Project Advisor**  
**RHOADES.MARK.MA**  
**TTHEW.1095020328**  
Digitally signed by  
MARK MATTHEW RHOADES, DN: cn=MARK MATTHEW RHOADES, o=U.S. Government, ou=DoD, ou=USN, email=TTHEW.1095020328, c=US, Date: 2012.08.30 12:01:28 -0700

**Mark Rhoades**  
**MSSE Project Advisor**

**PAULO.EUGENE.P**  
**ACELLI.1171407431**  
Digitally signed by  
PAULO EUGENE PACHELLI, DN: cn=PAULO EUGENE PACHELLI, o=USN, ou=USN, email=PAULO.EUGENE.PACHELLI.1171407431, c=US, Date: 2012.08.30 12:18:20 -0700

**Dr. Eugene Paulo**  
**MSSE Academic Associate**

Approved by:

**WHITCOMB.CLIFFOR**  
**D.ALAN.1010636481**  
Digitally signed by  
WHITCOMB CLIFFORD ALAN, DN: cn=WHITCOMB CLIFFORD ALAN, o=USN, ou=USN, email=WHITCOMB.CLIFFORD.ALAN.1010636481, c=US, Date: 2012.08.30 12:44:50 -0700

**Dr. Clifford Whitcomb**  
**Chair Dept. of Systems Engineering**

THIS PAGE INTENTIONALLY LEFT BLANK

v

## TABLE OF CONTENTS

I.	INTRODUCTION.....	1
A.	GENERAL APPROACH.....	1
B.	BACKGROUND.....	1
II.	PROJECT INFORMATION.....	3
A.	OBJECTIVES.....	3
B.	PROJECT CONSTRAINTS.....	3
C.	PROJECT ASSUMPTIONS.....	3
III.	SUPPORTING ACTIVITIES.....	5
A.	GENERAL SYSTEMS ENGINEERING APPROACH.....	5
B.	SOLUTION STRATEGY.....	5
C.	DESIGN RECOMMENDATIONS AND CONCLUSIONS.....	8
D.	RISK MANAGEMENT.....	8
IV.	MILESTONES AND DELIVERABLES.....	10
A.	INTERIM PROGRESS REVIEWS (IPR).....	10
V.	ORGANIZATION, ROLES, AND STAKEHOLDERS.....	12
A.	ORGANIZATION.....	12
1.	Team Members.....	12
2.	Faculty Advisors.....	13
B.	ROLES.....	14
C.	STAKEHOLDERS.....	17
VI.	PLAN OF ACTIONS AND MILESTONES.....	19
VII.	RESOURCES.....	21
VIII.	ACRONYMS.....	22
IX.	REFERENCES.....	23

THIS PAGE INTENTIONALLY LEFT BLANK

**LIST OF FIGURES**

Figure 1 Jet Fuel Flash Point Comparison (Holmgren, Jennifer, 2008) (Hovensa 2012) .....4  
Figure 2 Evolutionary Model Systems Engineering Process.....6  
Figure 3 Risk Likelihood Criteria Based on (Department of Defense 2006).....9  
Figure 4 Risk Consequence Criteria Based on (Department of Defense 2006).....9  
Figure 5 Team Biofuels Organizational Chart.....14  
Figure 6 Biofuels Team POA&M.....20



THIS PAGE INTENTIONALLY LEFT BLANK

**LIST OF TABLES**

Table 1 List of IPRs and Deliverables .....	11
Table 2 Team Bio-Fuels Membership, Backgrounds and Locations .....	13
Table 3 Biofuels Stakeholders .....	18
Table 4 Acronyms .....	22

THIS PAGE INTENTIONALLY LEFT BLANK

## I. INTRODUCTION

### A. GENERAL APPROACH

This Project Management Plan (PMP) lays out the approach of the Naval Postgraduate School (NPS) Cohort 311-1130 to the capstone project. The United States Department of Navy has expressed a need for a means to offset twenty-five percent of its annual aviation fuel usage with locally-produced algae-based biofuels. The capstone project team will work to address the transportation, distribution, mixing, and storage needs for this new fuel by engaging with the appropriate stakeholders, conducting a requirements analysis, and formulating a feasible solution.

Specifically, the PMP describes the problem, the working group (WG) tasks with deliverables, the constraints, and the objectives of the project. It identifies the various stakeholders, including this team, the advisors, and the customer. The PMP then describes the bounded project problem statement and the team's Systems Engineering (SE) strategy. This SE strategy forms the framework of the proposed analysis approach, including tools, needs analysis, value system design, requirements analysis, architecture, modeling / simulation strategy, alternatives analysis, tradeoffs, alternative evaluation strategy, risk analysis, and risk mitigation strategy. In addition, the PMP also presents the project schedule with major milestones.

### B. BACKGROUND

The U.S. Department of Defense (DoD) consumes over 130 million gallons of aviation fuel per year in Hawaii, all of which needs to be imported either as crude oil or refined aviation fuel from off-island. The U.S. DoD desires to offset the costs of importing fuel and reduce its dependence on foreign sources of petroleum by replacing up to 25% of the aviation fuel consumed in Hawaii with biofuel derived from Hawaiian algae stocks (Simonpietri 2011). This goal requires that the algae stocks be harvested and refined into aviation fuel in Hawaii and that refined aviation fuel be transported from the refinery to a storage facility, mixed with conventional fuels, and then distributed to a point of use in Hawaii. At least one other group is researching and developing recommendations for efficient means of growing, harvesting, and refining algae into useable biofuels. As a result, the focus of this team's research will be on

distributing biofuel from the refinery to the point of use by the Department of the Navy (DoN) in Hawaii.

Key stakeholders in the quest to distribute a locally grown algae-derived biofuel include the DoD, DoN, United States Department of Agriculture (USDA), Hawaiian State Government, Environmental Protection Agency (EPA), local refineries, and fuel transportation companies. These, and other, stakeholders will be engaged to assist the project team with identifying the true requirements and defining the metrics that will be used to measure the success of the final biofuel distribution solution.

## II. PROJECT INFORMATION

### A. OBJECTIVES

The title that the team has selected for this effort is, "A Systems Engineering Analysis of Distribution Systems for Algae-Based Biofuel Intended to Supplement Aviation Fuels Consumed by the Department of Navy in Hawaii." There are two main academic objectives of the capstone project. The first is to apply the systems engineering knowledge, skills, and techniques acquired in the NPS Master of Science in Systems Engineering (MSSE) program curriculum to solve an applicable real world problem. The second is to successfully complete the capstone project, including delivering all academic and stakeholder deliverables, within the three academic quarter time frame. The capstone project will focus on the post-production phase in the system life-cycle of using biofuels to supplement the aviation fuels consumed by the Department of Navy (DoN) in Hawaii. It will focus on implementing a strategy for the distribution of algae-based biofuel to DoN aircraft stationed within Hawaii.

### B. PROJECT CONSTRAINTS

The following is the list of capstone project constraints:

1. The project must be completed in three academic quarters.
2. The project must be accomplished within the time and manpower available.
3. The project must be accomplished without incurring any monetary costs.
4. Deliverables must meet NPS guidelines.

### C. PROJECT ASSUMPTIONS

The primary assumption is that the biofuel distribution is government only. It assumed that the DoN in Hawaii will exclusively consume the biofuel transported; thus the project will exclude commercial regulations governing use and distribution when not applicable to military entities.

The scope of the project will exclude the deliberation of methods for producing and refining biofuel. A preceding NPS System Engineering cohort will determine and provide the type of biofuel and refinery process during the second academic quarter of the project. The biofuel to be transported will initially be assumed to be in liquid form. Biodiesel has a higher

flash point than petroleum JP-4 and JP-8 and its flash point is similar to JP-5 (Holmgren, Jennifer, 2008) Biofuel flash point will be a critical consideration for determining regulations with handling and transportation.

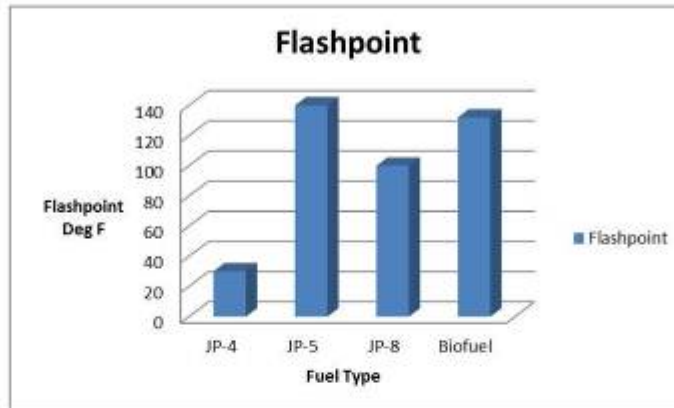

Figure 1 Jet Fuel Flash Point Comparison (Holmgren, Jennifer; 2008) (Hovensa 2012)

The properties of the biofuel assumptions will include: that it meets Navy fuel performance requirements, requires no change to aircraft or ship systems, and can be mixed or alternated with standard aviation fuel. These assumptions are consistent with current “drop-in” biofuel development efforts (U.S. DOE Alternative Fuels Data Center 2012). The DoD has set a goal to reduce its consumption of petroleum-based jet fuel in Hawaii by 25% before 2020. This decision affects all branches of the military. In an effort to meet this requirement, the DoD has chosen to pursue algae-based jet fuel as a “drop-in” alternative to jet fuel used by military aircraft stationed in, and flying through, Hawaii. DoD installations in Hawaii currently use 130 million gallons of jet fuel per year to sustain operations (Simonpietri 2011). The DoD must build the infrastructure to transport approximately 32 million gallons of biofuel from algae oil refineries to DoD installations throughout Hawaii.

### III. SUPPORTING ACTIVITIES

#### A. GENERAL SYSTEMS ENGINEERING APPROACH

The following sections provide specific information on the various aspects of the team's tailored systems engineering approach. As discussed below, a Vee© process model was chosen to guide the team through the systems engineering process (Forsberg and Mooz, Proceedings of the First Annual NCOSE Conference 1990) (Forsberg, Mooz and Cotterman, Visualizing Project Management, Third Edition 2005).

#### B. SOLUTION STRATEGY

In researching Systems Engineering (SE) models discussed in Blanchard & Fabrycky there were a number of models that could meet the needs of the Biofuels project scope. The three most common are the "Vee" process model, Waterfall process model and the Spiral process model (Blanchard and Fabrycky 2011). While all the basic models focus on getting the desires of the customer developed into a viable system, they all follow a similar path to reach that goal. The basic SE process starts with (Vaidyanathan 2011):

1. Customer/Stakeholder needs
2. Problem decomposition
3. System Design
4. Component Production
5. Component integration, verification, and validation
6. System integration, verification, and validation
7. Product delivery

The Biofuels system development is a completely new concept for fuel production, distribution and storage in Hawaii. Because of this new process of fuel production, distribution and storage an evolutionary model (Basic waterfall life cycle repeated through successive versions) fits the requirements of the Biofuels research project. The Evolutionary model (commonly used for new systems / products) fits the Biofuel system in that the process of biofuel production is currently in the early stages of research and development.



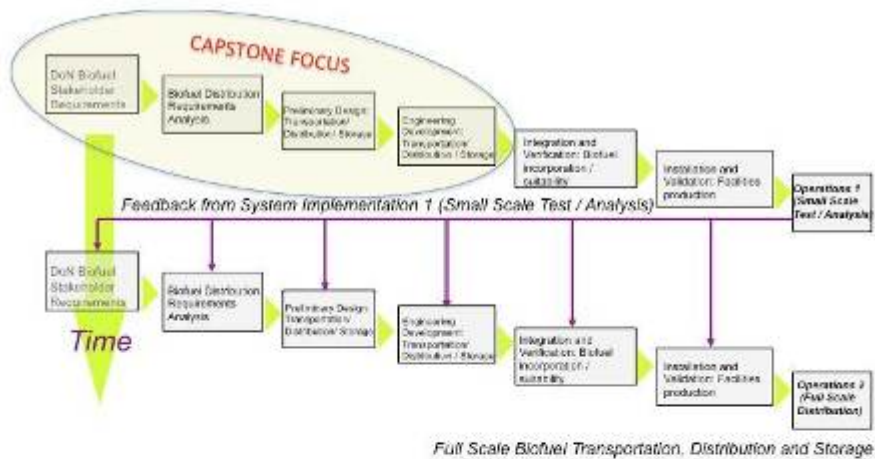

Full Scale Biofuel Transportation, Distribution and Storage

Figure 2 Evolutionary Model Systems Engineering Process

The basic SE steps, 1-7, were adapted into the Biofuel evolutionary model listed in Figure 1. The first or initial pass through the cycle will focus on the smaller scale biofuel transportation, distribution and storage concepts. Each basic life cycle pass will deliver an operational product or process (Vaidyanathan 2011). The second pass will look at the larger scale transportation, distribution, and storage of biofuel to DoN assets. It is this second pass, larger scale movement and storage that the biofuel research project will focus on, working on the assumption that biofuel production processes will be engineered into a cost-effective process that requires expansion into a larger scale production / distribution system. The advantage of this evolutionary model is that it implements feedback on a larger scale from one system implementation to the next. The feedback from stakeholders and engineers from one implementation to the next can drive a change in the system architecture if more effective means to develop the system are realized in the first evolution or “pass” through the system model (Vaidyanathan 2011). The focus of the Biofuels capstone project will be on the first four steps, as highlighted in Figure 1. The activities for each of these four steps are described in the following paragraphs.

**Step 1: DoD/DoN Biofuel Requirements:**

The first step of the SE process will be to analyze the requirements for the algae-based biofuel distribution systems set forth by the DoN. The voice of the customer will be gathered by means of stakeholder engagements. The customer(s) will supply a list of requirements, and from this list a set of criteria will be generated based on operational capabilities. The metrics for these criteria will be measurable in terms of system benefits and performance. Prioritization, based on customer feedback solicited during the first requirements phase, will be used to further refine our metrics and functional hierarchy into functions and sub functions, which will be ranked in accordance with system needs.

**Step 2: Biofuel Distribution Requirements:**

To develop a clear statement of goals, a needs analysis will be conducted. This will produce an effective need statement that will form the basis of the problem. Once stakeholder needs have been established, they will be sorted and ranked via a pairwise comparison matrix and analytic hierarchy process. This will yield a set of weighted attributes for the system to possess that translates a subjective assessment to a quantifiable metric. The attributes will be assessed in terms of Measures of Effectiveness (MOEs) and Measures of Performance (MOPs). These system attributes will be taken to the stakeholders for verification and validation and any conflicting results will be resolved with negotiations. Parameters will encompass all stages of the production and distribution of the algae-based biofuels system and will provide a way group and evaluate feasible design implementations.

**Step 3: Preliminary Design: Transportation/Distribution/Storage**

Alternatives will be generated during the Architectural Design phase of the lifecycle model through the use or combination of several established systems engineering methods. These methods will include but are not limited to brainstorming, research, quantitative value modeling decision matrixes, and a Zwicky morphological box. During the first pass of the evolutionary process, alternatives developed using these methods will cover a large array of system configurations for storage and distribution of the biofuel. As more passes are made through the model, the list of alternatives will be screened for feasibility against MOEs and MOPs and a smaller set of alternatives will be produced.

Once a list of alternatives has been generated, each will be thoroughly analyzed by means of modeling and simulation as well as cost/benefit and schedule comparisons. The simulation of these alternatives will enable an estimation of performance based on predetermined as well as stochastic parameters. The results of the modeling and simulation will allow the alternative architectures to be further narrowed based on performance and effectiveness criteria. The final list of possible alternatives will be taken to the stakeholders for verification, validation, and approval. Once a decision has been made, the process continues to the next step of component development.

#### **Step 4: Engineering Development: Transportation/Distribution/Storage**

The goal of the Component Development phase in the SE model will be a decision resulting in an established architecture for the transportation, distribution, mixing, and storage of algae-based biofuels. This architecture will support the needs and requirements of the customer, which will be validated at each stage of the process model, and verified once again once the final product is delivered.

### **C. DESIGN RECOMMENDATIONS AND CONCLUSIONS**

At the conclusion of the Biofuel capstone project, we will provide a recommended approach to implement an algae-based biofuel distribution system that is capable of handling up to 25% of the aviation fuels that the US Navy consumes in Hawaii. This recommendation will be generated using the systems engineering process defined above to obtain key stakeholder inputs, analyze the system requirements, establish the key parameters, and evaluate the alternative architectures through modeling and simulation. The project recommendations that will be delivered to the stakeholders will include a functional architecture, an operational concept definition, a conceptual system design, a cost analysis, and a risk assessment of implementation.

### **D. RISK MANAGEMENT**

The purpose of our risk management plan is to ensure that undesirable events that have the potential to affect the success of our project are identified. Once identified, the likelihood and consequence of these events will be assessed and mitigation strategies will be developed that will minimize the likelihood of the events. When the mitigation strategies are in place, the risks

will be continually monitored throughout the span of the project. Our risk management approach is based on Risk Management Guide for DoD Acquisition (Department of Defense 2006)

Risks can be identified to the Risk Manager by any member of the project team. Once a risk is identified, the Risk Manager will assess the risk based on the criteria shown in Figure 3 and Figure 4 and then generate a risk matrix. Each new risk will then be presented to the project team. Once the team has agreed on the appropriate mitigation strategies, the risk will be added to the risk database.

The Risk Manager is responsible for tracking all current risks in the risk database. All current risks will be presented to the team and the Project Advisors on a biweekly basis.

Likelihood	Level	Likelihood	Probability of Occurrence
	1	Not Likely	~10%
	2	Low Likelihood	~20%
	3	Likely	~50%
	4	Highly Likely	~70%
	5	Near Certainty	~90%

Figure 3 Risk Likelihood Criteria Based on (Department of Defense 2006)

Consequence	Level	Technical Performance	Schedule	Cost
	1	Minimal or no consequence to technical performance.	Minimal or no impact.	Minimal or no impact.
	2	Minor reduction in technical performance or supportability, can be tolerated with little or no impact on program; same approach retained.	Additional activities required, able to meet key dates. Slip < 2 weeks.	Budget increase or unit production cost increases > 1% of Budget.
	3	Moderate reduction in technical performance or supportability with limited impact on program objectives; workarounds available.	Minor schedule slip, no impact to key milestones. Slip < 1 month.	Budget increase or unit production cost increase > 5% of Budget.
	4	Significant degradation in technical performance or major shortfall in supportability; may jeopardize program success; workarounds may not be available or may have negative consequences.	Program critical path affected, all schedule float associated with key milestone exhausted. Slip < 2 months.	Budget increase or unit production cost increase 10% of Budget.
	5	Severe degradation in technical performance; Cannot meet KPP or Key technical/supportability threshold; will jeopardize program success; no workarounds available.	Cannot meet key program milestones. Slip > 2 months.	Exceeds APBA threshold 10% of Budget.

Figure 4 Risk Consequence Criteria Based on (Department of Defense 2006)

## **IV. MILESTONES AND DELIVERABLES**

### **A. INTERIM PROGRESS REVIEWS (IPR)**

Two In-Process Reviews (IPRs) will be held prior to submitting a final capstone report, the purpose of which is to ensure that the Biofuels team is on-track and to address any concerns along the way. During IPR #1 the Biofuels team will present their research findings along with the results of Stakeholder interviews and the preliminary needs analysis. After IPR #1, the team will conduct requirements analysis, including functional analysis and requirements allocation, and develop a preliminary design. The preliminary design will be the result of Analysis of Alternatives (AoA), Concept Definition, and modeling and simulation. The major milestones and deliverables are listed in Table 1:

Deliverable	Description	Date
<b>PMP</b>	<b>Project Management Plan</b>	<b>13-Aug-12</b>
<b>IPR 1</b>	<b>Problem Background</b>	<b>13-Sep-12</b>
	Information Gathering	
	Refine Problem Definition	
	Perform Stakeholder Needs and Requirements Analysis	
	Define System Boundaries and Capabilities	
<b>IPR 2</b>	<b>Iterative SE Process</b>	<b>6-Dec-12</b>
	Concept Development	
	Requirements and Constraints Analysis	
	Preliminary Design	
	Engineering Development	
	Explore Solution Space	
	Develop Functional and Physical Architecture	
	Develop Operational Concept	
<b>Draft Capstone Report</b>	<b>Design Summary from work conducted and plan ahead</b>	<b>14-Feb-13</b>
<b>Final IPR</b>	<b>Iterative SE Process</b>	<b>14-Mar-13</b>
	Concept Development/ Evaluation	
	Concept Refinement Based on Requirements and Needs	
	Perform Cost Analysis	
	Complete Engineering Development	
	Develop Model / Simulation	
	Finalized Architecture	
<b>Final Report</b>	<b>Deliver to Dept. Chair &amp; Project Presentation</b>	<b>15-Mar-13</b>
	Design Recommendations	
	Project Summary	

Table 1 List of IPRs and Deliverables

## V. ORGANIZATION, ROLES, AND STAKEHOLDERS

### A. ORGANIZATION

The Project Team is divided into two parts, 1) Technical and 2) Administrative with the roles and responsibilities of “Research” and “Presentation(s)” designated as the responsibility of all. The backup of all of the abovementioned roles will be determined as necessary and on a case by case basis. The following is a list of Team Members and Faculty Advisors that are involved in the Capstone Project effort for the Naval Postgraduate School’s (NPS) Biofuels Cohort MSSE & MSES 311-1130:

#### 1. Team Members

<b>Team Members</b>	<b>Professional Background</b>	<b>Location</b>
<b>Roge Adversalo</b>	<b>Strike Force Interoperability Strike Group Engineer</b>	<b>NSWC PHD Detachment San Diego, CA</b>
<b>Larry Coleman</b>	<b>Computer and Systems Engineer</b>	<b>NSWC PHD Port Hueneme, CA</b>
<b>David Featherby, LCDR, USN</b>	<b>Bio-Chemical and Systems Engineer, Naval Aviator</b>	<b>VT-22, Kingsville, TX</b>
<b>Jonathan Hopkins</b>	<b>Mechanical Engineer</b>	<b>NSWC, Carderock Division, Bethesda, MD</b>
<b>Kristen Kerns, LT, USN</b>	<b>Chemical and Systems Engineer, Surface Warfare</b>	<b>NSWC PHD Port Hueneme, CA</b>
<b>Patrick Knowles</b>	<b>Electrical and Computer Engineer</b>	<b>NSWC, Carderock Division, Bethesda, MD</b>
<b>John Lester</b>	<b>Computer Science, and Naval Aviator</b>	<b>Naval Air Station Whiting Field, Milton, FL</b>

<b>Michael Lisella</b>	<b>Electrical and Systems Engineer</b>	<b>NUWC Newport, RI</b>
<b>Kevin Neaves</b>	<b>Chemical and Systems Engineer</b>	<b>NAVSEA Washington, D.C.</b>
<b>Richard Seriani</b>	<b>Electrical and Systems Engineer</b>	<b>NUWC Detachment Norfolk, VA</b>
<b>Joseph Villucci</b>	<b>Electrical and Systems Engineer</b>	<b>NUWC Newport, RI</b>
<b>Anmarie Young</b>	<b>Aerospace and Weapons Systems Engineer</b>	<b>NSWC, Indian Head, MD</b>

Table 2 Team Bio-Fuels Membership, Backgrounds and Locations

## 2. Faculty Advisors

The Biofuels Team Faculty Advisors are Professors Mark Rhoades and Brigitte Kwinn. Both Professor Kwinn and Rhoades are NPS faculty members. Professor Rhoades is a Senior Lecturer and is the Associate Chair for Educational Technology for the Systems Engineering department at NPS. Professor Kwinn is a Lecturer at the NPS Department of Systems Engineering, Graduate School of Engineering and Applied Sciences.

Faculty Advisors are responsible for guiding and mentoring the capstone team members through the process of completing a successful capstone project that satisfies the requirements of scholarly work at the appropriate level as it applies to the Naval Post Graduate School. More specifically, the advisors frequently guide and provide continuing feedback on the Capstone Teams development/progress of the Capstone Project by providing intellectual appropriateness of the proposed activities, the reasonableness of project scope, acquisition of necessary resources and expertise. Finally, both the Faculty Advisors provide adequate and timely feedback; establish key academic milestones (communicate them to the team members) and appropriately evaluate the student on meeting these milestones (CAPSTONE PROJECT GUIDE DL SE PROGRAMS 2006).



**TEAM BIOFUELS  
ORGANIZATIONAL CHART**

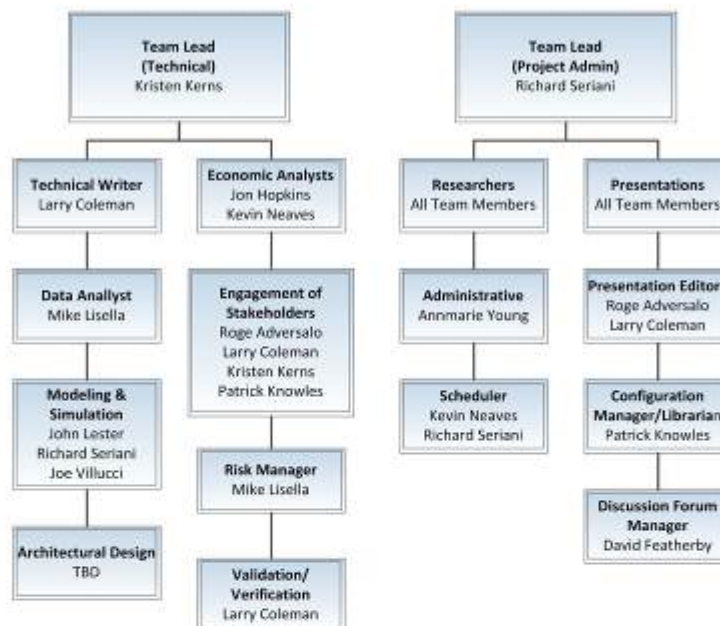

Figure 5 Team Biofuels Organizational Chart

**B. ROLES**

**Team Leads:** Members serving in this capacity are responsible for management, oversight, and communication of the Capstone Project. Similarly, these individuals are responsible for the monitoring and achievement of Team Bio-Fuels qualitative and quantitative results/deliverables.

**Researchers:** Research is the responsibility of all team members through extensive systematic investigation into qualitative and/or quantitative facts. These facts may be used to

support theories, hypotheses and assumptions related to the Bio-Fuels Capstone Project and Problem Statement in order to facilitate the delivery of a concrete deliverable. Discussion Forum Manager: The team members serving in this capacity are responsible for organizing, updating and controlling the forum in Sakai.

Configuration Manager and Librarian: This team member is responsible for the maintenance and consistency of the changes, control and documentation of deliverables. More specifically, a team member serving in this capacity will be responsible for archiving, organizing and updating all applicable references, documents and deliverables associated with the Bio-Fuels Capstone Project.

Presentations: Team Members serving (in turn) as presenters are responsible for reviewing and analyzing the applicable presentation they are presenting to the NPS Advisors and all applicable audiences (to include various stakeholders).

Economic Analysts: Team Members serving in this capacity are responsible for the extensive evaluation of economics (e.g. quantitative and qualitative in flavor) as they relate to the Bio-Fuels capstone project and problem statement. Additionally, these team members will be responsible for the collection, analysis of data/metrics and display/illustration of the results in a visual and/or graphical form. They will use various Cost Estimation Tools and/or Labs either provided by NPS or acquired through research efforts.

Presentation Editors: Team Members serving in this capacity will be responsible for the technical formatting and editing of all Microsoft Power Point Briefs (to include high-level briefings to stakeholders).

Administrative Officer: A team member operating in this capacity is responsible for the coordination of team activities and the distribution of tasks. Additionally, the team member serving in this role is responsible for capturing meeting minutes and metrics that can be used for future activities associated with the Bio-Fuels capstone project and the overall progression of the efforts.

Engagement of Stakeholders: Team members serving in this capacity are responsible for the direct contact and interaction with all parties involved, affected and that may have a vested interest in the Bio-Fuels capstone project (e.g. sponsors). Additionally, these team members will

be responsible for the collection, analysis of data/metrics and display/illustration of the results in a visual and/or graphical form of any information provided by stakeholders (e.g. interview question results, minutes, reports).

**Data Analyst:** The team member serving in this capacity is responsible for the collection, analysis of data/metrics and display/illustration of the results in a visual and/or graphical form.

**Risk Management:** The team member operating in this capacity is responsible for the identification, assessment and prioritization of risks as they relate to the Bio-Fuels Capstone Project and Problem Statement. Additionally, these team members will be responsible for the collection, analysis of data/metrics and display/illustration of the results in a visual and/or graphical form.

**Modeler:** Team members operating in this capacity are responsible for the representation of the applicable system(s) (e.g. in a simplified manner in theory or actual scaled depiction in parts of the system and/or the system as a whole) as they relate to the Bio-Fuels capstone project and problem statement. Additionally, these team members will be responsible for the collection, analysis of data/metrics and display/illustration of the results in a visual and/or graphical form. These members will use various Modeling and Simulation Tools and/or Labs either provided by NPS or acquired through research efforts.

**Scheduler/Maintainer:** Team members operating in this capacity are responsible for the maintenance; management, oversight, and communication of the Bio-Fuels capstone project schedule. Moreover, team members operating in this role are vital to the success of the Bio-Fuels Capstone Project's success in achieving project due dates, milestones and timely delivery of deliverables.

**Technical Writer:** The team member operating in this capacity is responsible for the formulation of a clear understanding of the purpose of the project, documents, documentation and all applicable deliverables as they relate to project, audience and stakeholders. Additionally, this individual will be responsible for gathering applicable information and filtering non-applicable information (as deemed necessary by the team) while using his or her knowledge of technical communication and jargon (both primitive and modern).

Architectural Design: Team members operating in this capacity are responsible for the definition of a system embodied in its components, their relationship to each other, the applicable environment(s) and the principles guiding its design and evolution. More specially, these team members will address functional decomposition, interfaces, standards and protocols. Finally, these team members will be responsible for the collection, analysis of data/metrics and display/illustration of the results in a visual and/or graphical form in relation to SE and Architectural Design.

Verification and Validation: Team members operating in this capacity are responsible for utilizing independent procedures for checking and substantiating system requirements and specifications in terms of the overall fulfillment of intended purposes. Additionally, these team members will be responsible for the collection, analysis of data/metrics and display/illustration of the results in a visual and/or graphical form in relation to Verification and Validation.

### **C. STAKEHOLDERS**

Stakeholders have been assigned to one of five categories:

- Sponsors: Provide technical and monetary support for project
- Decision Makers: Key personnel in the approval chain to implement this process
- Users: Groups of personnel who will utilize the process in their missions
- Partners: Groups who may benefit from similar implementation of this process
- DoD Contractors: Companies providing systems to the DoD that could utilize biofuels

Specific stakeholders have been categorized in Table 3.

<b>Sponsors</b>	<b>Decision Makers</b>	<b>Users</b>	<b>Partners</b>	<b>DoD Contractors</b>
USN R&D Research and	Office of the President	DoD Department	Department of Air Force	Lockheed Martin
Academia (Researchers,	US Congress	Pacific Command	Department of the Army	Boeing
Office of Naval Research (ONR)	Senate Armed Services	NAVAIR Naval Air	Department of the Marine Corps	Northrop Grumman
	JCOS Joint Chief of Staff	NWAS Naval	Department of Homeland Security	General Dynamics
	SECNAV Secretary of	Refiners	Department of Transportation	Austral
	EPA Environmental	Distributors	Department of Energy	
		Aviation Squadrons	Military Sealift Command	
			NAVSEA Naval Sea Systems Command	
			Commercial Aviation	

Table 3 Biofuels Stakeholders

## **VI. PLAN OF ACTIONS AND MILESTONES**

Shown below in Figure 6 is the preliminary schedule of major tasks and milestones for the Biofuels project. More in-depth schedules will be developed as necessary throughout the project. The proposed schedule is intended to map our Systems Engineering Process to key deliverables, such as In-Process Reviews (IPR), and lead to an on-time delivery of a final capstone report at the conclusion of the project. For example, the first IPR will include results from the team's research, stakeholder interviews, and needs analysis.

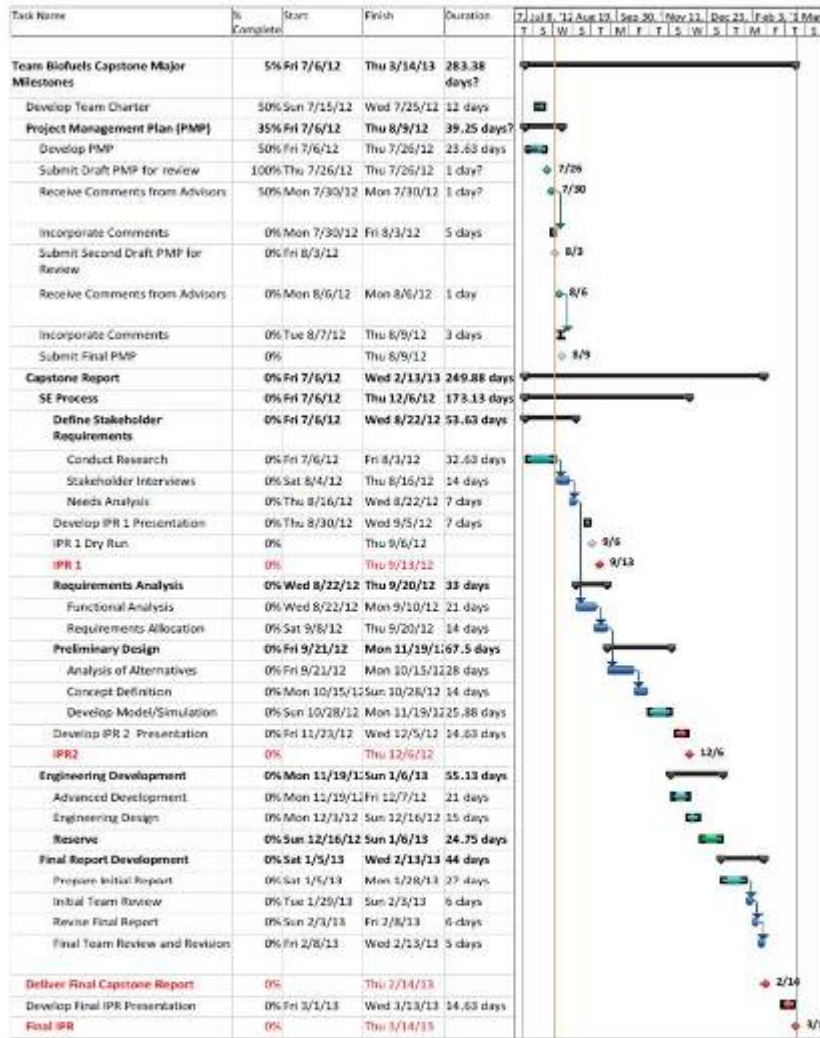

Figure 6 Biofuels Team POA&M

## VII. RESOURCES

A number of resources will be used to obtain the information necessary to solve the problem of distributing algae-based biofuel to U.S. Navy installations in Hawaii. These resources include, but are not limited to:

1. Sakai Internet Repository and Workspace
2. Dudley Knox Library
3. NPS Virtual Private Network for access to ExtendSIM and other simulation tools
4. Microsoft Office Suite (Word, Excel, PowerPoint, Access, Project)
5. CORE – A comprehensive modeling environment designed to facilitate Model-Based Systems Engineering. CORE links all elements of a system through a central model, providing greater visibility into risk drivers and identifying design weaknesses.



## VIII. ACRONYMS

Acronym	Denotation
DoD	Department of Defense
DON	Department of the Navy
EPA	Environmental Protection Agency
IPR	Interim Progress Reviews
MOE	Measures of Effectiveness
MOP	Measures of Performance
NAVAIR	Naval Air Systems Command
NAVSEA	Naval Sea Systems Command
NPS	Naval Post Graduate School
NWAS	Naval Warfare Assessment
NUWC	Naval Undersea Warfare Center
PACOM	Pacific Command
POA&M	Plan of Actions and Milestones
PMP	Project Management Plan
POCs	Points of Contact
SE	Systems Engineering
USDA	United States Department of Agriculture

Table 4 Acronyms

## IX. REFERENCES

- Blanchard, Benjamin S., and Wolter J. Fabrycky. *Systems Engineering and Analysis, Fifth Edition*. Upper Saddle River: Prentice Hall, 2011.
- "CAPSTONE PROJECT GUIDE DL SE PROGRAMS." Monterey: Naval Postgraduate School, March 7, 2006.
- Department of Defense. *Risk Management Guide for DOD Acquisition, Sixth Edition (Version 1.0)*. DoD Instruction, DoD, 2006.
- Forsberg, Kevin, and Hal Mooz. "Proceedings of the First Annual NCOSE Conference." 1990.
- Forsberg, Kevin, Hal Mooz, and Howard Cotterman. *Visualizing Project Management, Third Edition*. Hoboken: John Wiley & Sons, Inc., 2005.
- Godffrey, Ed. "Naval Sea Systems Command Media." *Naval Sea Systems Command*. January 11, 2012. [http://www.navsea.navy.mil/Media/SNA2012/Jan%2011%20Godfrey%20-%20Final%20Slides%20for%20Surface%20Navy%20Association%20\(11%20Jan%2012\).pdf](http://www.navsea.navy.mil/Media/SNA2012/Jan%2011%20Godfrey%20-%20Final%20Slides%20for%20Surface%20Navy%20Association%20(11%20Jan%2012).pdf).
- Holmgren, Jennifer. "Bio Aviation Fuel." Brussels: UOP, LLC, March 12-14, 2008.
- Hovensa. *Hovensa Material Safety Data Sheets*. 2012. <http://www.hovensa.com> (accessed 08 12, 2012).
- Simonpietri, Joelle. "Hawaii Energy Policy Forum." *University of Hawaii at Manoa*. May 20, 2011. <http://www.hawaiienergypolicy.hawaii.edu/PDF/2011/2011-5-20-Joelle-Simonpietri.pdf>.
- U.S. DOE Alternative Fuels Data Center. 07 30, 2012. [http://www.afdc.energy.gov/fuels/emerging\\_dropin\\_biofuels.html](http://www.afdc.energy.gov/fuels/emerging_dropin_biofuels.html) (accessed 08 12, 2012).
- Vaidyanathan, Ravi. *Systems Development and Life Cycle Models*. London, April 2011.

THIS PAGE INTENTIONALLY LEFT BLANK

## INITIAL DISTRIBUTION LIST

1. Defense Technical Information Center  
Ft. Belvoir, Virginia
2. Dudley Knox Library  
Naval Postgraduate School  
Monterey, California