



Calhoun: The NPS Institutional Archive
DSpace Repository

Theses and Dissertations

1. Thesis and Dissertation Collection, all items

2018-06

DESIGN STRATEGIES AND TACTICS TO DEFEAT CO-ORBITAL ANTI-SATELLITE CAPABILITIES

Hanlon, Edward A.

Monterey, CA; Naval Postgraduate School

<http://hdl.handle.net/10945/59677>

Downloaded from NPS Archive: Calhoun



Calhoun is a project of the Dudley Knox Library at NPS, furthering the precepts and goals of open government and government transparency. All information contained herein has been approved for release by the NPS Public Affairs Officer.

Dudley Knox Library / Naval Postgraduate School
411 Dyer Road / 1 University Circle
Monterey, California USA 93943

<http://www.nps.edu/library>



NAVAL POSTGRADUATE SCHOOL

MONTEREY, CALIFORNIA

THESIS

**DESIGN STRATEGIES AND TACTICS TO DEFEAT
CO-ORBITAL ANTI-SATELLITE CAPABILITIES**

by

Edward A. Hanlon

June 2018

Thesis Advisor:

Oleg A. Yakimenko

Co-Advisor:

George Boyarko

Second Reader:

Douglas Van Bossuyt

Approved for public release. Distribution is unlimited.

THIS PAGE INTENTIONALLY LEFT BLANK

REPORT DOCUMENTATION PAGE			<i>Form Approved OMB No. 0704-0188</i>	
Public reporting burden for this collection of information is estimated to average 1 hour per response, including the time for reviewing instruction, searching existing data sources, gathering and maintaining the data needed, and completing and reviewing the collection of information. Send comments regarding this burden estimate or any other aspect of this collection of information, including suggestions for reducing this burden, to Washington headquarters Services, Directorate for Information Operations and Reports, 1215 Jefferson Davis Highway, Suite 1204, Arlington, VA 22202-4302, and to the Office of Management and Budget, Paperwork Reduction Project (0704-0188) Washington, DC 20503.				
1. AGENCY USE ONLY (Leave blank)		2. REPORT DATE June 2018	3. REPORT TYPE AND DATES COVERED Master's thesis	
4. TITLE AND SUBTITLE DESIGN STRATEGIES AND TACTICS TO DEFEAT CO-ORBITAL ANTI-SATELLITE CAPABILITIES			5. FUNDING NUMBERS	
6. AUTHOR(S) Edward A. Hanlon				
7. PERFORMING ORGANIZATION NAME(S) AND ADDRESS(ES) Naval Postgraduate School Monterey, CA 93943-5000			8. PERFORMING ORGANIZATION REPORT NUMBER	
9. SPONSORING / MONITORING AGENCY NAME(S) AND ADDRESS(ES) N/A			10. SPONSORING / MONITORING AGENCY REPORT NUMBER	
11. SUPPLEMENTARY NOTES The views expressed in this thesis are those of the author and do not reflect the official policy or position of the Department of Defense or the U.S. Government.				
12a. DISTRIBUTION / AVAILABILITY STATEMENT Approved for public release. Distribution is unlimited.			12b. DISTRIBUTION CODE A	
13. ABSTRACT (maximum 200 words) Spacecraft play an increasingly significant role in U.S. military operations. For adversaries looking to degrade U.S. capability to mitigate tactical advantage, this reliance provides another attack vector and represents a potential U.S. weakness. Recent technological developments have resulted in the increased proliferation of "attack" satellites. A strong understanding of the orbital domain and orbital dynamics is necessary to effectively evade these attackers. Much like the early days of aviation, space innovation has outpaced existing tactics, techniques and procedures. This thesis aims to provide an overview of the domain and possible evasive maneuvers to facilitate further tactics development. It begins with an overview of the threat landscape to provide background on what to expect and proceeds to discuss what positions of advantage are in space and how thrust commands translate to maneuvers at different time scales. It details the development of an engagement simulator and provides insight as to the effect of various evasion thrust patterns. From this, an evasion tactic is developed and tested in the simulator. This tactic proves effective in evading an aggressor while also demonstrating substantial fuel savings over alternative methods. Finally, different spacecraft parameters are compared to determine what hardware improvements provide the best evasive capability.				
14. SUBJECT TERMS satellite, evasion, survivability, anti-satellite, defense, co-orbital, space, maneuver			15. NUMBER OF PAGES 103	
			16. PRICE CODE	
17. SECURITY CLASSIFICATION OF REPORT Unclassified	18. SECURITY CLASSIFICATION OF THIS PAGE Unclassified	19. SECURITY CLASSIFICATION OF ABSTRACT Unclassified	20. LIMITATION OF ABSTRACT UU	

THIS PAGE INTENTIONALLY LEFT BLANK

Approved for public release. Distribution is unlimited.

**DESIGN STRATEGIES AND TACTICS TO DEFEAT CO-ORBITAL
ANTI-SATELLITE CAPABILITIES**

Edward A. Hanlon
Ensign, United States Navy
BS, U.S. Naval Academy, 2017

Submitted in partial fulfillment of the
requirements for the degree of

MASTER OF SCIENCE IN SYSTEMS ENGINEERING

from the

**NAVAL POSTGRADUATE SCHOOL
June 2018**

Approved by: Oleg A. Yakimenko
Advisor

George Boyarko, Air Force Space Command
Co-Advisor

Douglas Van Bossuyt
Second Reader

Ronald E. Giachetti
Chair, Department of Systems Engineering

THIS PAGE INTENTIONALLY LEFT BLANK

ABSTRACT

Spacecraft play an increasingly significant role in U.S. military operations. For adversaries looking to degrade U.S. capability to mitigate tactical advantage, this reliance provides another attack vector and represents a potential U.S. weakness. Recent technological developments have resulted in the increased proliferation of “attack” satellites. A strong understanding of the orbital domain and orbital dynamics is necessary to effectively evade these attackers. Much like the early days of aviation, space innovation has outpaced existing tactics, techniques and procedures. This thesis aims to provide an overview of the domain and possible evasive maneuvers to facilitate further tactics development. It begins with an overview of the threat landscape to provide background on what to expect and proceeds to discuss what positions of advantage are in space and how thrust commands translate to maneuvers at different time scales. It details the development of an engagement simulator and provides insight as to the effect of various evasion thrust patterns. From this, an evasion tactic is developed and tested in the simulator. This tactic proves effective in evading an aggressor while also demonstrating substantial fuel savings over alternative methods. Finally, different spacecraft parameters are compared to determine what hardware improvements provide the best evasive capability.

THIS PAGE INTENTIONALLY LEFT BLANK

Table of Contents

1	Introduction	1
1.1	Background	1
1.2	Motivation	2
1.3	Objective	4
1.4	Organization	4
2	Space and Anti-satellite Capabilities	7
2.1	Types of Threats	7
2.2	Criticality of Co-orbital Threats	16
2.3	Exploration of Defensive Options	17
3	Model Development	21
3.1	Modeling Environment	21
3.2	Orbit Model	22
3.3	Spacecraft Model	25
3.4	Model Integration	26
3.5	Model Verification.	31
4	Mechanics of Space Engagements	33
4.1	Relative Motion in Orbit	33
4.2	Maneuver Basics	38
4.3	Maneuver Difficulty	39
4.4	Threat Classification and Triggers.	41
5	Tactics Development	45
5.1	Direction Tests	45
5.2	Minimum- ΔV	54
5.3	Evolved Controller.	58

6	Spacecraft Design Factors	63
6.1	Spacecraft Parameters	63
6.2	Design of Experiment	64
6.3	Recommendations	70
7	Conclusion	71
	List of References	73
	Initial Distribution List	79

List of Figures

Figure 3.1	Co-orbital evasion simulation in Simulink.	21
Figure 3.2	Co-orbital evasion simulation highlevel view.	22
Figure 3.3	Visual depiction of radial, in-track, cross-track (RIC) frame. Source: [28].	23
Figure 3.4	Visual depiction of spacecraft thrust parameters.	25
Figure 3.5	Spacecraft Simulink model.	26
Figure 3.6	Spacecraft tactic blocks.	27
Figure 3.7	Spacecraft proximity operations block.	28
Figure 3.8	Example RIC coordinate time history	29
Figure 3.9	Example trajectory in RIC coordinates.	29
Figure 3.10	Example thrust command profiles for Red and Blue vehicles.	30
Figure 3.11	Example intercept data graphic.	30
Figure 3.12	Comparison between STK Astrogator propagator and the Simulink model.	31
Figure 4.1	Time histories showing relative distance as a function of time based on various starting positions.	34
Figure 4.2	Effect of applying a positive cross-track thrust.	35
Figure 4.3	Effect of applying negative radial thrust.	36
Figure 4.4	Effect of applying positive in-track thrust.	37
Figure 4.5	Effect of thrust application.	38
Figure 4.6	Schematics of ΔV calculations.	38
Figure 4.7	ΔV computed based on time of intercept.	40

Figure 4.8	Depiction of ease of transit (reachability).	41
Figure 4.9	Radial and in-track threat envelope for a six-hour intercept. . . .	43
Figure 4.10	Cross-track and in-track threat envelope for a six-hour intercept. .	43
Figure 5.1	Tested evasion thrust directions.	46
Figure 5.2	Cost of four-hour intercept vs. range.	46
Figure 5.3	Red aggressor tactic (a), and Blue constant thrust tactic (b). . . .	47
Figure 5.4	Cost of four-hour intercept after evasion in various directions. . .	48
Figure 5.5	Position vs time without Blue maneuver (a), and with continuous in-track Blue maneuver (b). NOTE: different axis.	50
Figure 5.6	Relative position of spacecraft without Blue maneuver (a), and with continuous in-track Blue maneuver (b). NOTE: different axis. . .	50
Figure 5.7	Thrust profiles without Blue maneuver (a), and with continuous in-track Blue maneuver (b).	50
Figure 5.8	Position vs time for in-track evasion (a), and radial and in-track evasion (b).	52
Figure 5.9	Thrust profiles for in-track evasion (a), and radial and in-track evasion (b).	52
Figure 5.10	Time/intercept profiles for in-track evasion (a), and radial and in-track evasion (b).	52
Figure 5.11	Position vs time for in-track evasion (a), and radial, in-track and cross-track evasion (b).	53
Figure 5.12	Thrust profiles for in-track evasion (a), and radial, in-track and cross-track evasion (b).	53
Figure 5.13	Time/intercept profiles for in-track evasion (a) and radial, in-track and cross-track evasion (b).	53
Figure 5.14	The Red aggressor tactic (a), and Blue's minimum- ΔV evasion tactic (b).	55

Figure 5.15	Position vs time for single direction pulse toward host (a), and relative position of the two spacecraft (b).	57
Figure 5.16	Thrust profiles for engagement scenario (a), and difficulty of achieving rendezvous and expected rendezvous time (b).	57
Figure 5.17	ConOp logic for evasion maneuver.	59
Figure 5.18	Position vs time for single direction pulse toward host (a), and relative position of the two spacecraft (b). Notice how the minimum separation has increased from 0 m in Figure 5.15 to 16 km.	60
Figure 5.19	Thrust profiles for engagement scenario (a), and difficulty of achieving rendezvous and expected rendezvous time.	60
Figure 5.20	Comparison of relative fuel consumption for engagements from a variety of directions using the in-track only controller (a), and the evolved in-track + radial controller (b).	61
Figure 6.1	Main effects plot for engagement evasion with binary success criteria based on closest point of approach of 10 km.	67
Figure 6.2	Main effects plot for engagement evasion with fuel based success criteria based on closest point of approach of 10 km.	67
Figure 6.3	Comparison of ΔV intercept requirements with constant maneuver (a) and pulsed maneuver (b).	69
Figure 6.4	Interaction plot for engagement evasion with range-based success criteria based on closest point of approach of 10 km.	69

THIS PAGE INTENTIONALLY LEFT BLANK

List of Tables

Table 2.1	Satellite attack methods: likelihood of use vs depth of existing research on a 1-5 scale	17
Table 5.1	Input-Output Mapping	58

THIS PAGE INTENTIONALLY LEFT BLANK

List of Acronyms and Abbreviations

ACS	attitude control system
ADCS	attitude determination and control system
ASat	anti-satellite
C+DH	command and data handling system
Comms	communication system
ConOp	concept of operations
CW	Clohessy-Wiltshire
DoD	Department of Defense
DOE	design of experiment
EPS	electrical power system
GEO	geosynchronous orbit
LEO	low earth orbit
NPS	Naval Postgraduate School
USG	United States Government
USN	U.S. Navy
RIC	radial, in-track, cross-track

THIS PAGE INTENTIONALLY LEFT BLANK

Executive Summary

Space is an increasingly contested environment. The U.S. National Security Strategy of 2017 defines space as a “priority domain” [1]. The National Space Strategy of 2018 highlights how “competitors and adversaries have turned space into a warfighting domain” and how the U.S. must be prepared to “deter, counter, and defeat threats in the space domain” [2]. As part of this preparation, an understanding of how to respond to approaching co-orbital threats to current spacecraft is necessary. Furthermore, the designs of future spacecraft must consider defensive operations to deter and evade attack.

This paper describes an approach to this preparation and provides recommendations as to the terminology, tactics and design features necessary to harden and defend orbital infrastructure.

Threats today fall into three primary categories:

- *Ground-based interceptors*– includes the kinetic Dong Neng missile China used in its 2007 anti-satellite (ASat) test and the electro-magnetic ground to space laser system fielded in Russia.
- *Cyber attacks*– as complex computer systems, Spacecraft are vulnerable to attacks similar to those undertaken on critical terrestrial infrastructure on a daily basis.
- *Co-orbital threats*– threats based on other spacecraft, especially those made possible by the advent of on-orbit “servicing” vehicles with potential for dual use.

The paper argues in Chapter 2 that co-orbital threats are the most effective; unlike cyber attacks, they can be used to demonstrate the ability to hold a target at risk while avoiding the orbital debris concerns inherent in kinetic solutions. This versatility, coupled with the ease of development under the guise of “on-orbit servicing” missions make them perhaps the most useful for space combat.

A Simulink model was made to simulate these potential co-orbital interactions and allow two spacecraft to “dogfight.” The model is based on Clohessy-Wiltshire (CW) equations and is described in detail in Chapter 3. The model allows for tactics development and verification across a variety of orbital conditions. Using these tactics, parametric analysis of spacecraft

design parameters can be conducted to determine what physical components matter in space combat. The model was used to determine the mechanics of space engagements and identify positions of value and vulnerability so that space operators can conduct appropriate mission planning.

Chapter 4 provides an overview of the effects orbital dynamics has on space engagements. Given the orbital dynamics, unlike terrestrial combat, there is little relation between distance and difficulty of access. Threats should not be classified based on distance to their target; they must instead be assessed by the magnitude of the required velocity change to intercept. This classification method provides a more accurate estimate of rendezvous difficulty and allows the defending spacecraft to react appropriately.

The ultimate goal of each engagement is survival. For most spacecraft, any unforecast fuel consumption reduces the useful life of the spacecraft. In developing defensive tactics, the defensive objective was to maintain separation from the pursuer while minimizing the defender's fuel consumption and maximizing the aggressor's consumption. Tactics development was undertaken using two identical modeled spacecraft. Simulations applying thrust in a variety of directions in response to an aggressor starting in various positions produced an understanding of the best general evasive maneuver. These effects are incorporated into the development of tactics to prevent rendezvous.

Given the role of orbital dynamics in evasive maneuver, the resulting tactic is dependent both on the enemy starting location and their planned intercept time. A four-step evasion tactic was developed in Chapter 5.

1. If the pursuer starts radially above the defender, the defender applies thrust in negative directions as determined by the following steps. Thrust in the positive direction is applied if the pursuer starts below.
2. While the pursuer is not on a trajectory to rendezvous within 15% of the orbital period, in-track thrust is applied to produce a radial change over a long period, thereby increasing in-track separation.
3. When the pursuer is tracking to intercept in less than 15% of the orbital period, the defender switches to radial thrust.
4. If the chosen evasion technique does not increase the rendezvous difficulty over the course of 30 minutes, an all-direction evasion technique is applied.

This evasion tactic results in the defender using 30-50% less fuel than the aggressor while still evading. When using this evasion technique, the spacecraft's ability to rapidly and repeatedly fire its thruster with a minimum delay between thruster firing is the driving performance factor, while thruster power and maneuver intensity are less critical. Spacecraft with continuous thrust engines, like those equipped with electric propulsion, are at an advantage in engagement scenarios.

References

- [1] D. Trump, "National security strategy of 2017," Washington, DC, USA 2017.
- [2] D. Trump, "National space strategy of 2018 (fact sheet)," Washington, DC, USA 2018

THIS PAGE INTENTIONALLY LEFT BLANK

Acknowledgments

I would like to thank Admiral Frank Bowman and the Bowman Scholar Committee for providing the opportunity for me to attend the Naval Postgraduate School (NPS).

I would also like to acknowledge with appreciation the contributions of Air Force Space Command's Orbital Engagement Maneuver Integrated Validation Team (AFSPC OEM IVT), particularly Dr. George Boyarko.

I would like to thank Dr. Oleg Yakimenko for his advice, guidance and patience throughout the thesis process.

Finally, I would like to thank my family for their support and assistance.

THIS PAGE INTENTIONALLY LEFT BLANK

CHAPTER 1:

Introduction

This chapter frames the background and motivation for the thesis. It summarizes the political shift in space and discusses how spacecraft design must be altered to meet new challenges. Finally, it summarizes the organization of the thesis.

1.1 Background

Spacecraft are an integral arm of the U.S. military, and provide, among other things, a substantial force multiplier. The U.S. relies on spacecraft to provide everything from weather predictions to weapons' guidance. It is a reliance largely exclusive to the United States. While many other countries have military spacecraft, the U.S. DoD is the single largest satellite operator in the world by a large margin. It spends \$44B annually on space assets, an order of magnitude more than its nearest rivals (China: \$4.3B and Russia: \$1.6B) [1].

This dependence disparity creates an interesting susceptibility. A Chinese news agency observed that “for countries that could never win a war by using the method of tanks and planes, attacking the U.S. space system may be an irresistible and most tempting choice” [2]. There are increasing efforts to develop and test anti-satellite (ASat) weapons [2]. China, Russia, and the U.S. have all pursued the development of such space weapons. Russia has launched several (non-impacting) tests, while China and the U.S. have recently demonstrated the ability to destroy a target spacecraft [2].

Secreted hundreds or thousands of miles overhead, each spacecraft is the multi-year work of hundreds of engineers and millions of dollars. Unlike ground vehicles, they cannot be replaced in a tactical time scale. There is no stockpile of spacecraft waiting to be activated, and damaged spacecraft cannot be shipped back home for repair and redeployment. The assets on-orbit or on the way to the pad right now are the assets that are available for the foreseeable future; as yet there is no way to scale production.

Even if a stockpile of spacecraft were available and ready for launch, there is no tactical

way to put them in orbit. It takes months to build a launch vehicle, and even with those on hand, the most reliable rockets are delayed an average of ten days. For comparison, the ground portion of Desert Storm lasted three days.

Until recently, spacecraft have been considered safe. The launch of the first artificial satellite, Sputnik, on October 4, 1957, established that spacecraft could cross international borders with impunity. In many ways, this precedent was set, not due to any formal agreement between states, but because there was nothing the U.S. or any other country did or could do to prevent such overflight [3].

From this event, precedent – both legal and doctrinal – was set. Spacecraft were safe platforms to conduct missions free from hostile interference or complaint. Slowly spacecraft have become essential parts of day-to-day life, providing communications, surveillance, and navigation capability, ultimately becoming a critical infrastructure placed in space.

1.2 Motivation

Recently, nations have directly challenged the Sputnik precedent. The U.S. National Security Strategy of 2017 defines space as a “priority domain” [4]. The National Space Strategy of 2018 highlights how “competitors and adversaries have turned space into a warfighting domain” and how the U.S. must be prepared to “deter, counter, and defeat threats in the space domain” [5].

Since 2000, there have been two high profile kinetic space weapon demonstrations. The first was the 2007 Chinese ASat missile demonstration, where a Dong Neng missile was used to destroy an orbiting weather satellite [6]. This test generated a large cloud of debris, the effects of which are still impacting operations over ten years later. In 2008, the U.S. also demonstrated its ability to destroy satellites, when an SM-3 missile launched from the USS Lake Erie was used to destroy the USA-193 spacecraft [7].

The era of safe space is over. Today’s rhetoric represents the first direct questioning of the Sputnik precedent that has until now gone unchallenged. Unfortunately, current space systems and operators are under-prepared for this paradigm shift. Until now, spacecraft design philosophy has viewed efforts to add defensive systems or weapons to spacecraft as costly and mostly unnecessary. The only known armed spacecraft was the Russian Almaz

military manned reconnaissance spacecraft, which was equipped with a 23mm Rikhter rapid-fire cannon [8]. It was tested only once.

Even while current spacecraft are technologically unprepared for space combat, new threats are being launched. The rapid development of autonomous vehicles, miniaturization, computer vision and advanced processing have enabled numerous co-orbital “repair” projects [9]. Satellites designed to rendezvous with and modify current spacecraft represent both a spectacular opportunity to improve the satellite industry and an effective means of degrading enemy capability. These advances, and others like them, have created the technological ability to produce the current political situation in space.

These co-orbital threats represent a substantial shift in the kinetic space threat environment. Using a co-orbital vehicle instead of a missile or impactor results in substantially less space debris, a necessary consideration given the vocal international concerns about orbital debris. It offers a more responsive capability, one that can selectively degrade enemy satellites rather than destroy them outright, and also establishes the ability to implement non-attributed attacks that may be indistinguishable from routine failures due to the space environment.

Spacecraft and spacecraft operators today can easily be compared to aircraft and aircrew in the years leading up to World War I. Before the war, heavier-than-air aircraft had only fought in small skirmishes, with impromptu weapons. At the beginning of the war, aircraft were primarily used for transport or intelligence gathering. Aviators shot at each other with handguns and dropped bombs on ground targets by hand. These implements were quickly realized to be insufficient. As the war progressed, the need for dedicated “fighter” aircraft and similarly trained aircrews was apparent.

Tactics were developed based on the operators’ experiences. Oswald Boelcke first published the precepts for air combat in his book *Dicta Boelcke* [10]. Written based on his extensive combat experience, it consisted of a list of rules for air combat, identifying tactics and approaches that provided users with an advantage over their enemy.

Spacecraft have not been faced with combat situations, and spacecraft operators have not had the opportunity to develop warfighting experience in contested space. This thesis aims to preempt the demand for both by providing a framework for their development.

1.3 Objective

This study aims to provide satellite operators with insight on how to defend their space assets against attack and inform decision makers about what spacecraft capabilities require improvement, which includes informing spacecraft manufacturers as to what design modifications will best assure spacecraft survivability.

This research is framed around three research questions

1. What matters in the physics of an orbital engagement?
2. What spacecraft parameters are the most sensitive to its survival?
3. What spacecraft maneuver tactics provide the highest possibility of survival?

The study purposely uses generic spacecraft rather than examining specific satellite designs, which is necessary to ensure general results that can be tailored for specific solutions.

The objective of the defender is assumed to be to maintain long-term capability – that is the ability to use the asset for weeks or years after the engagement. It is also assumed that the defender is willing to degrade short-term capability to meet this objective. Furthermore, the aggressor is assumed to have a set time limit to accomplish its objective.

1.4 Organization

To address the aforementioned research question, this thesis is organized as follows.

To establish the threat environment, Chapter 2 describes the current space-focused weapons systems facing satellites today. It examines both the threats themselves and the chain of events necessary for each weapon to effect damage. It also discusses the limitations of current spacecraft and space architectures in responding to the threat environment.

As a general background for those interested in pursuing further research, Chapter 3 examines how the author modeled space engagements and discusses the limitations of the model and opportunities for further research.

Chapter 4 is written to describe the mechanics of space engagements and identify positions of value and vulnerability for space operators. Furthermore, Chapter 5 details the tactics the author developed to evade co-orbital threats and determines what options operators have

to avoid orbital engagement.

Finally, for spacecraft designers and requirements writers, Chapter 6 uses the tactics described in Chapter 4 to provide a parametric analysis of the spacecraft systems involved in orbital engagement and determines which make the most difference in a space encounter.

THIS PAGE INTENTIONALLY LEFT BLANK

CHAPTER 2: Space and Anti-satellite Capabilities

This chapter discusses the various threats to current spacecraft. Specifically, It examines threats from a survivability standpoint; characterizing the target spacecraft's susceptibility and vulnerability to them. It explains the importance of co-orbital weapons, and the unique benefits that may accelerate their adoption, and concludes by arguing that the most effective defense is some form of evasive maneuver.

2.1 Types of Threats

Compared to vehicles operating in Earth's atmosphere, on the ground or under water, satellites are quite vulnerable. In the battle to save weight and volume to reduce launch costs, they are built with extremely fine tolerances. The only external forces they must withstand are launch forces, but those are experienced in a controlled, stowed configuration. Once on-orbit, the spacecraft is only acted on by its own forces, and therefore structure can be minimized. With this minimization, and through the complexity of spaceflight, they frequently fail; not due to hostile action, but because of the space environment or design flaws.

The process of interfering with a spacecraft's function is therefore quite trivial. When examining threat mechanisms, it is useful to consider the weapon progression as follows:

Starting Location → Mechanism → Effect

As spacecraft are relatively fragile, a core principle is avoidance. As such, the point of origin is critical in determining an appropriate response. There are three possibilities for launching these weapons

- *Ground-based*– Weapons that start on the ground. Ground-based weapons have limited windows of operation and are geographically fixed. They are easily attributable based on the region of origin.

- *Co-orbitals*– Weapons that originate on-orbit. These attacks are not bound to a specific region, and therefore are harder to attribute and avoid.
- *Cyber-physical*– Weapons that have no material form. These can attack any layer of the satellite system from any attack vector.

These starting locations provide the first layer of weapons classification. The next layer is the damage mechanism itself, which dictates the maneuver severity or design changes necessary to prevent loss of the asset should intercept be possible. There are numerous mechanisms capable of creating such damage, which fit into four broad categories [11]

- *Kinetic*– Impactors, fragmentation devices, and co-orbitals.
- *Non-Kinetic Physical*– Lasers and energy weapons.
- *Electronic*– Electronic jamming or other EM spectrum warfare.
- *Cyber*– Cyber attack on the spacecraft.

Finally, it is important to consider the range of activities for which each weapon is useful. Not every engagement necessarily results in the complete destruction of a satellite, and in many cases that may not be the desired outcome. There are a few commonly identified objectives for anti-satellite actions [12]

- *Deception*– Target reports incorrect information.
- *Disruption*– Target’s capability temporarily degraded.
- *Denial*– Target’s capability temporarily disabled.
- *Degradation*– Target’s capability degraded irreparably.
- *Destruction*– Complete loss of target spacecraft.

These objectives govern what weapons systems enemies are likely to pursue development in, and what current systems should be expected to face.

All of these factors must be taken into account when considering the best means of minimizing the impact of these weapon systems.

2.1.1 Cyberspace Systems

Spacecraft are complex computer controlled devices. As such, they are vulnerable to typical computer attack. While spacecraft are fortunate in that their control systems and

programming are boutique and therefore not vulnerable to typical or generic software attacks, security through obscurity is rarely an effective defense.

Nearly all aspects of spacecraft systems are vulnerable to cyber attack, and unlike ground systems which can be reset, reformatted, or replaced, spacecraft must make do with what is onboard. Should that prove insufficient, any one of the following results could occur [13]

- *Deception*– Advanced cyber attacks may be able to modify mission payloads to return data that the adversary creates. This modification could happen at any level, ranging from within the payload itself, to the main spacecraft processor, to the radio, to ground control equipment.
- *Disruption*– By adjusting spacecraft parameters at opportune moments (or even just changing one or two bits and triggering a fault case), it is possible to prevent a spacecraft from conducting its mission effectively at specific times.
- *Denial*– Some software changes can render a spacecraft inoperative until ground control is able to reload code, or an appropriately implemented safe-mode is activated.
- *Degradation*– The prime or other satellite function is damaged through some physical manipulation generated by malicious code (similar to Stuxnet) [13].
- *Destruction*– The spacecraft is left uncontactable despite any safe-modes (either by destroying communications, ADCS, or solar equipment or by rewriting safe-mode procedures).

Cyber threats can come from a variety of sources. They can be transmitted to the spacecraft by malicious ground stations, inserted into routine traffic by compromised ground control equipment, or input into systems via their payload's normal function [13]. Additionally, most spacecraft have easily accessible ground programming ports to conduct pre-launch programming and diagnostics, which may not be hardened against intrusion.

Cyber threats are particularly useful because they are difficult to attribute or even detect. They have a low cost of entry and can be accomplished by both nation-states and non-state actors. The damage they can create is fully scalable depending on the type of vulnerability available.

Like all cyber attacks, however, they are also challenging to demonstrate. While missiles and lasers can be tested and demonstrated against space objects, cyber attacks are only

effective when their access route is unknown. The target is far more likely to believe they can defend against a cyber attack than a kinetic or non-kinetic physical attack. Given the challenge associated with demonstrating a cyber threat, it is challenging to use the threat of cyber attack as deterrence against an action.

Ultimately, like terrestrial systems, effective cyber protection must be implemented systematically. By their nature, it is not possible to airgap spacecraft (as communications are over the air), and thus additional security measures must be present. As many spacecraft today are built using common commercial components (satellite bus) designed by one of only a few manufacturers, it is likely that satellite source code is accessible to adversaries. Furthermore, transmissions between the ground and the spacecraft can be intercepted by aircraft, drones, other spacecraft, or even a person with a well-placed antenna. As such, communications schemes must be well encrypted with changeable encryption keys and replay attack resilience.

When possible, satellites should be thoroughly tested by security researchers throughout their development process, or at the very least spacecraft software designers must have a security-focused mindset similar to any software designer on the ground. Merely being a space object is no longer sufficient protection.

2.1.2 Ground-Based Weapons Systems

Ground-based weapons are weapons or attacks launched from ground locations. This category includes ship-based and aircraft based weapons. While ground weapons take a variety of forms, by nature of being ground-launched, they have several similarities.

As ground weapons are not launched to orbit before use, they can be cheaper to build. Often, ground-based weapons are multi-purpose or based on existing anti-aircraft/ballistic missile defense system. They can be constructed and fielded covertly.

Ground-launched weapons have limited access opportunities to space assets, governed by the space objects orbit. As a result, they are predictable. Furthermore, ground-launched weapons are also susceptible to weather conditions.

Ground-based weapons can typically create kinetic, non-kinetic physical, and electronic damage to spacecraft.

Kinetic

Ground-launched kinetic interceptors, also called Direct Assent Anti-satellite Weapons, use a rocket motor to launch on a parabolic sub-orbital flight that results in an intercept with the target object. Early kinetic ground weapons were based on modified mid-course ballistic missile interceptors. Typical kinetic interceptors follow a parabolic trajectory and do not enter orbit with the targeted object. Most have divert fuel to adjust for any evasive maneuvers the targeted spacecraft makes.

Ground-launched kinetic weapons have significant effect and cannot generate limited damage. Given the high closing speeds inherent in a direct launch, and the relative fragility of spacecraft, any form of kinetic impact is likely to destroy the satellite outright. This impact generates a large quantity of orbital debris.

The generation of this debris is the principal challenge facing ground-launched kinetic impactors. Space debris is a high profile issue that is of interest to the entire world. The Kessler Syndrome theory suggests a there is a critical mass of debris where interactions between objects result in the generation of further debris, ultimately rendering space inaccessible [14].

Geosynchronous orbit (GEO) is one of the critical orbits that is especially vulnerable to space debris. GEO is the only orbit in which a spacecraft can remain stationary over a single point on Earth, making it particularly important for communications and broadcast spacecraft. While in low and medium Earth orbit satellites are spaced in a wide variety of orbital regimes based on their use case and launch vehicle, geostationary spacecraft are all located at the same altitude and inclination. As a result, any debris generated in GEO affects the entire belt. Furthermore, unlike low earth orbit (LEO), GEO is high enough that atmospheric drag is insufficient to cause debris to re-enter Earth's atmosphere on their own. If enough debris accumulates in GEO, the entire orbit becomes inaccessible, and the communications architecture currently in place will no longer function.

In 2007, the Chinese government was condemned by the international community for their direct ascent ASat test which resulted in the generation of over 3,000 unique pieces of trackable debris [15]. These debris are expected to remain in orbit well past 2035, preventing use of that orbit and threatening numerous other satellites. In 2011, the International Space Station came within 6 km of impacting with debris [16].

Given the danger of rendering entire orbits inaccessible and denying humanity access to space, ASat weapons are unlikely to be fielded except in cases of extrema. This restriction substantially limits their use.

Nevertheless, numerous nations have developed or are developing direct ascent missiles. There are several examples of tested/fielded directed anti-satellite weapons. The first countries that have tested or proposed such systems are the US, Russia, and China.

Specifically, the U.S. has developed several directed ASat systems [17].

- *ALMV*– The “Air-Launched Miniature Vehicle” was a two-stage missile intended to be air-launched by an F-15. It had a kinetic warhead on board. It successfully destroyed a satellite in October 1985. The debris from this incident persisted until 2002 [17].
- *KE-ASAT*– An army program created in the late 1980s that used a kinetic impactor; it was never tested [17].
- *SM-3 Missile*– An SM-3 missile from a Ticonderoga Class Guided Missile Cruiser successfully destroyed a satellite in Low Earth Orbit in 2008 [7].

Russia has also developed a successful direct ascent ASat weapon.

- *PL-19 Nudol*– A direct ascent anti-satellite missile. As of December 2016, the system had completed five tests. Each launch was from a base in central Russia [18].

China has conducted several high-profile ASat demonstrations. Most of these demonstrations have used the Dong Neng Missile.

- *Dong Neng*– The Dong Neng program is a high-Earth orbit interceptor that destroys spacecraft with a kinetic impactor. Its development incorporated the results of the 2007 Chinese ASat missile test [19].

Non-kinetic Physical

Directed energy weapons have progressed dramatically since their initial development in the late 1980s. Directed energy weapons can have a number of effects on spacecraft

- *Disruption*– Directed energy weapons can be used to blind or overwhelm sensors.

Spacecraft optics and antenna tend to have high magnification or gain to observe targets. A dramatic increase in incident energy results in sensor blooming and prevent reception of the desired information.

- *Denial*– Like disruption, by flooding sensors with incident energy, it is possible to degrade the sensors to the point of preventing access to any ground information.
- *Degradation*– At high energy levels, sensors and affiliated equipment can be overheated and destroyed.
- *Destruction*– At extremely high levels, directed energy weapons can have direct effects on spacecraft systems regardless of optics or gain. Microwave weapons can exploit vulnerabilities in the spacecraft frame to induce power surges and bit-flips in onboard equipment. Lasers can burn through solar array and damage spacecraft structure.

There are several advantages to ground-based directed energy weapons. Energy weapons require large amounts of electricity; by basing these weapons on the ground, they can be supported by existing ground systems and be co-located with the sites they are intended to protect. They are also relatively inexpensive. Directed energy weapons also avoid the creation of orbital debris, and can be adjusted to provide a wide array of damage mechanisms. Depending on the application, they can be difficult to detect and attribute.

The directed energy weapons are, however, limited by their terrestrial placement. They can only attack objects they have a line of sight to, which limits them to attacking only when a spacecraft passes overhead. They are vulnerable to Earth atmospheric conditions. Compared to co-orbital directed energy weapons, they require substantially more power given the longer ranges.

Directed energy weapons have seen substantial development recently to combat terrestrial threats, ranging from small drones to intercept missiles. These developments are also translatable to space applications.

The U.S. has a variety of on-going laser projects. One unclassified project has demonstrated a laser attack on a spacecraft

- *Miracle*– The Mid-Infrared Advanced Chemical Laser was fired on a U.S. Air Force satellite M.S.T.I.-3 in 1997 and successfully permanently blinded the spacecraft [20].

Russia has had a number of programs examining directed energy weapons. Most recently, the Russian government has identified an offshoot of the Beriev A-60 program for space applications [21]

- *Anti-satellite Complex*– An interfax report mentions the creation of a laser complex that is intended to suppress space based reconnaissance means [21].
- *Airborne Laser*– Furthermore, an airborne laser intended to target satellites is under development based on past USSR research [21].

Like Russia, China is also pursuing non-kinetic directed energy weapons

- *2005 Test*– In 2005, researchers successfully blinded a spacecraft in LEO with a 50 kilowatt laser gun from the Xinjiang province [22].

2.1.3 Co-orbital Threats

Co-orbital threats are threats that originate from an on-orbit platform. These can take a variety of forms and have a variety of goals. However, to best take advantage of their location, they all aim to rendezvous or perform proximity operations with their targets. These are some of the most complex weapons systems, as they are, effectively, fully functioning satellites on top of being weapons systems.

Co-orbital weapons are very versatile and can serve a variety of purposes.

1. *Deception*– A co-orbital system can feed incorrect information directly into the system, or it can interface with the payload via ground service ports to replicate the effect.
2. *Disruption*– Co-orbital systems have numerous opportunities to disrupt operations. Merely parking in between the sun and a solar array would be sufficient to curtail the target's available power.
3. *Denial*– By either obstructing or jamming payload systems, a co-orbital system can effectively deny use of the spacecraft to ground controllers.
4. *Degradation*– A co-orbital system can easily damage external components of the spacecraft, in many cases by doing as little as brushing up against them.
5. *Destruction*– Disassembly of key components, kinetic impacts or even detonating explosives can result in the complete destruction of the targeted spacecraft.

A co-orbital system's versatility is one of its primary benefits. It can be challenging to attribute damage due to a co-orbital attacker to a specific nation. Co-orbital attackers can strike multiple satellites in similar orbits, making them particularly well suited for the Geo-belt. They can perform close approaches to demonstrate that the launching nation could have damaged the target, or that the target is under threat. They can also be used to examine the designs of targets to establish technical capability.

Co-orbital threats are not particularly well suited for Low Earth Orbit, as there are numerous orbital regimes in use, and transitioning between different spacecraft would be fuel prohibitive. Co-orbital threats are more complicated and expensive to build and require substantial engineering knowledge.

It is easy to obfuscate the development of co-orbital threats. In the commercial satellite world today, there is a great deal of interest in satellite repair and satellite refueling/reuse. This interest has resulted in the design and construction of orbital repair satellites. These repair satellites are not necessarily intended to damage other spacecraft; however, the capability to remove and replace a malfunctioning solar array includes the ability to destroy a solar array. Thus, effort spent developing peaceful solutions can support hostile intentions as well.

The U.S. has demonstrated on-orbit rendezvous and basic repair with the DARPA Orbital Express program. Further research work is underway at the Naval Research Laboratory on the RSGS mission to provide on-orbit refueling capability [23].

Russia has developed a yet unnamed on-orbit proximity operations spacecraft launched in December 2013 and designated Kosmos-2499 by satellite trackers. That spacecraft is rumored to be an Anti-satellite robot. It conducted close-in rendezvous operations with its launch vehicle to demonstrate intercept capability [24].

China has also launched similar capability, the Aolong-1. It is a small satellite officially designed to perform space debris mitigation missions by using a small robotic arm to grapple satellites and launch them back towards Earth [25].

2.2 Criticality of Co-orbital Threats

When determining which weapon systems to examine in the scope of this thesis, two parameters were weighted. The first was the likelihood of use for each weapon system. The second was the magnitude and extendability of current research to each domain. The objective was to find the area where the most work could be done and the most significant impact made. Co-orbital threats are perhaps the most likely attacks to be seen and have the least amount of published work completed.

2.2.1 Likelihood of Use

The likelihood of deploying different weapons against satellites varies.

Ground Launched (Physical) Kinetic attacks are easily traceable using existing on-orbit infrastructure and are challenging to defend on the world stage. They are almost certain to cause substantial space debris events, and if used at scale may render entire orbital regimes unusable – both for the target and the attacker. These limitations result in a system that can only be used in extremis.

Existing Ground Launched (Energy) weapons have not yet progressed to the point of being able to destroy spacecraft on-orbit outright. While they have excellent capability to degrade or destroy payload systems, these attacks can be thwarted by not operating the payload over threatened areas. Larger, more capable lasers are under development. As these weapons come on-line, it may be necessary to examine possible defenses. Given the speed at which they can act, it is challenging to envision a solution that allows for preservation of capability against this far future threat.

Cyber attacks against space infrastructure are incredibly likely. Terrestrial networks have already demonstrated the value of cyber attacks and cyber defense, and it is reasonable to assume this will continue to affect space.

Co-orbital threats are seeing a great deal of developmental interest. Co-orbital systems can be used to conduct “flag waving” campaigns, to selectively damage targets, and to conduct reconnaissance missions. Given their versatility, untraceability, and the research interest, it seems likely that co-orbital weapons will see use.

2.2.2 Existing Research

There is a variety of research ongoing in different areas, aligned with existing threats.

Some limited research exists on possible defenses against ground-launched weapons. Ultimately, active and passive countermeasures used on aircraft and ships to decoy inbound missiles could translate to a space context [26].

Researchers have also explored protecting aircraft against laser strikes, but there remains little research applied specifically to the space environment [27].

Little distinguishes spacecraft systems and ground systems from a cyber perspective. As such, ground approaches to cyber resiliency should extend to space applications without substantial challenges.

While ample research exists discussing optimizing rendezvous operations, there is little to no research studying the preventive measures to avoid rendezvous.

The results of this analysis are summarized in Table 2.1. While both ground-based energy and co-orbital weapons are areas of interest, the current co-orbital capability far surpasses the lethal energy weapon capability. As such, the best application of research was determined to be co-orbital weapon defense.

Table 2.1. Satellite attack methods: likelihood of use vs. depth of existing research on a 1-5 scale

Attack	Likelihood	Depth	Criticality
Ground Physical	1	3	3
Ground Energy	4	2	8
Cyber	5	1	5
Co-orbital	5	4	20

2.3 Exploration of Defensive Options

To best evaluate defensive opportunities in a co-orbital engagement, it is necessary to examine the events leading up to a successful intercept. The series of events begins when the enemy decides to attack and ends when the co-orbiting threat accomplishes its objective,

as follows:

1. *Attacker determines that space assets are in use*– The first step in the engagement is the enemy’s decision to attack space assets. This step can be deterred or prevented through policy and diplomatic means.
2. *Target spacecraft detected by attacker*– After the decision to attack is made, the attacker must be able to determine what vehicle to target. This selection can be made more difficult by utilizing stealth features and inexpensive decoys.
3. *Attacker determines target spacecraft orbit and optimal intercept location*– After the target spacecraft has been detected, its orbit must be determined. The efficacy of this characterization is dependent on the adversary’s capability.
4. *Attacking asset enters orbit with spacecraft*– The attacking co-orbiter must be able to reach the same orbit as its target. For spacecraft in common orbits (GEO), it is likely that the co-orbiter is positioned correctly initially.
5. *Attacking co-orbiter intercepts target satellite*– The attacker must then be able to maneuver to intercept its target. The target can make this process more difficult through maneuver, jamming, or deception techniques.
6. *Attacker creates damage effect*– Damage prevention measures are dependent on the nature of the attack. If the objective is to gain access to an onboard diagnostic port, a simple shield or software disable would be sufficient. If the objective is a collision, then far more substantial defenses must be in place.

Any break in this event chain results in the successful defense of the target satellite. The defeats for step one are dependent on diplomacy and the international legal system. Ultimately, this is the most critical element of space warfare; however, to provide a credible deterrence or enforcement plan there must be alternatives to the peaceful solution.

Steps 2 and 3 both involve spacecraft detection. Preventing detection is primarily a function of the attacker’s detection system; stealth features and decoy performance are dependent on the system they are trying to defeat. Given the rapid advances and increased funding in the space situational awareness sphere, it is challenging to determine effective stealth features. Given the long life of spacecraft, it is reasonable to assume any conceivable stealth in place on launch will not last for the entirety of the spacecraft’s operational life.

The initial location of the co-orbiting aggressor and its fuel capacity dictates the ability to

enter orbit with a target (Step 4). When possible, missions should use atypical orbits far from other spacecraft to maximize the cost of using a co-orbital weapon.

If it is assumed, like in Steps 2 and 3, that sensor defeats are not a lasting solution, then the intercept process described in Step 5 is dependent on the thrust capabilities of the two spacecraft and the direction of each thrust impulse. This capability is governed by the spacecraft design, and by the tactics employed by the spacecraft operator. This thesis aims to help inform both of those decisions.

Step 6 is entirely dependent on both the target spacecraft and the attacking co-orbital's mission and design and can only be evaluated on a case-by-case basis.

Summary

There is extensive proliferation of space weapons, ranging from traditional ground-launched missiles to cyber attacks. Of these attack methods, the co-orbital threat has several advantages which make it a likely platform for use in the immediate future. Given this likelihood, there is a need to develop means of defense against co-orbital threats. After an analysis of the attack event chain and the opportunities for defensive development, maneuver tactics were selected as the best candidate for development.

THIS PAGE INTENTIONALLY LEFT BLANK

CHAPTER 3: Model Development

This chapter describes the development of an orbital model capable of simulating co-orbital satellite engagement. It details the assumptions made in the modeling process, and the verification steps conducted to assure accurate simulations. Finally, it discusses some of the limitations of the model and why these limitations are acceptable.

3.1 Modeling Environment

The system was modeled in Simulink. Figure 3.1 shows an overview of the model. The model is composed of two nearly identical subsystems: one for the attacker (Red) and one for the defender (Blue). Each spacecraft has its own tactics block which controls commanded ΔV , an orbit model which estimates the spacecraft's position, and an output block which exports data to Matlab.

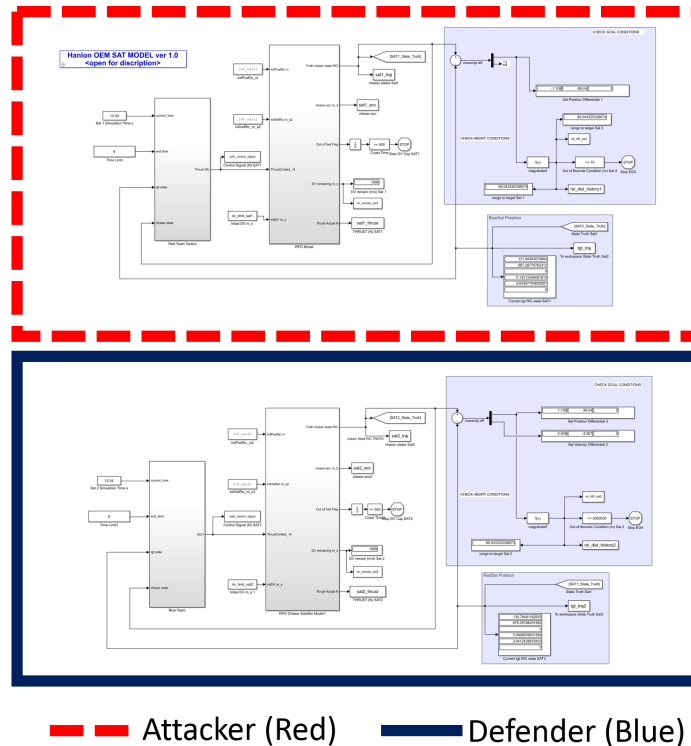

Figure 3.1. Co-orbital evasion simulation in Simulink.

Figure 3.2 presents a flowchart of a high-level view of the model, highlighting subsystem inputs and outputs.

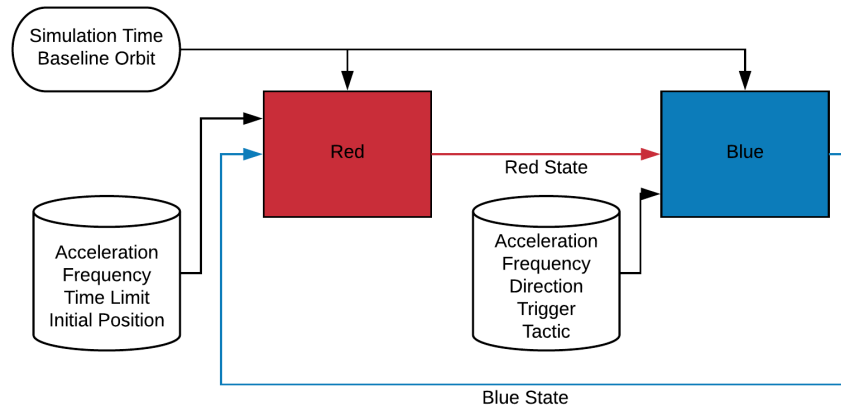

Figure 3.2. Co-orbital evasion simulation highlevel view.

3.2 Orbit Model

The core object of the model was to allow for rapid and dramatic changes in spacecraft velocity to simulate a co-orbital engagement. The model needed to be lightweight to allow comprehensive designs of the experiment to be run in a minimal amount of time, while still maintaining sufficient fidelity to be applicable to real-life engagements. Furthermore, the model needed to be portable and extendable, to allow for use by other organizations or as subsets of other models.

The model selected was a modified variant of the Air Force Space Command's Orbital Engagement Maneuver team's geosynchronous orbit simulator. The model was written in Simulink using the State Position Matrix generated by the Clohessy-Wiltshire (CW) equations.

3.2.1 Coordinate Frame

This model uses the radial, in-track, cross-track (RIC) frame for all calculations. The RIC frame is well suited for rendezvous because it defines positions relative to the object of interest. The Radial component is the Naider (Earth pointing) vector of the spacecraft,

with positive values representing locations higher than the orbital altitude. The in-track component is along the velocity vector, with positive values representing locations ahead of the spacecraft. The cross-track component represents positions to the left and right of the spacecraft, effectively orbits with different inclinations. Figure 3.3 shows a visual depiction of the RIC coordinate frame.

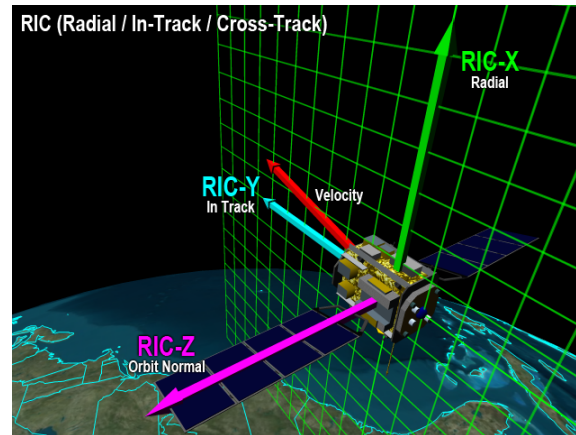

Figure 3.3. Visual depiction of RIC frame. Source: [28].

3.2.2 Model Propagator

To model orbital engagement, there needs to be a means of estimating the spacecraft's position over time while accounting for orbital mechanics and any maneuvers. This study uses a so-called "low fidelity" propagator which only accounts for Newtonian mechanics based on Earth's gravity (where Earth is represented as a point mass) and the spacecraft's maneuver forces (modeled as velocity changes).

The propagator chosen is based on CW equations. The CW equations, developed in 1960, are used for terminal guidance in satellite rendezvous. They are the result of a linearization of the two body problem, and rely on the following assumptions:

- The bodies of interest are at close range;
- The target orbit is circular or near circular;
- There are no external disturbance forces.

The CW equations of motion provide relative motion of a spacecraft in orbit around a central

body with respect to a constant point in the RIC frame. This constant point rotates in the orbit as time progresses. For the simulation, this constant point is the defender's position if it never maneuvered. The point remains stationary in the RIC frame, but in the inertial reference frame it follows the orbital path the defender would take should it not maneuver. The CW equations of motion are: [29]

$$\begin{aligned}\ddot{r} &= 3n^2r + 2ni \\ \ddot{i} &= -2n\dot{r} \\ \ddot{c} &= -n^2c\end{aligned}\quad (3.1)$$

$$\text{Where } n = \sqrt{\frac{\mu}{a^3}}, \quad a = -\frac{\mu}{2\epsilon}, \quad \epsilon = \frac{v^2}{2} - \frac{\mu}{r} \quad (3.2)$$

In Equations 3.1 and 3.2, n is the orbital parameter defined by the orbital altitude, μ is the gravitational constant of Earth, a is the magnitude of the semi-major axis, ϵ is the orbital energy (based on orbital velocity v and altitude r). The r , i , and c terms represent the components of the RIC frame.

The CW equations can be used to generate a state transition matrix, which takes an input of the spacecraft's current state (position and velocity in the RIC frame) and a future time-step and outputs the state at that future point

$$\begin{bmatrix} r \\ i \\ c \\ \dot{r} \\ \dot{i} \\ \dot{c} \end{bmatrix} = \begin{bmatrix} 4 - 3 \cos nt & 0 & 0 & \frac{1}{n} \sin nt & \frac{2}{n}(1 - \cos nt) & 0 \\ 6(\sin nt - nt) & 1 & 0 & -\frac{2}{n}(1 - \cos nt) & \frac{1}{n}(4 \sin nt - 3nt) & 0 \\ 0 & 0 & \cos nt & 0 & 0 & \frac{1}{n} \sin nt \\ 3n \sin nt & 0 & 0 & \cos nt & 2 \sin nt & 0 \\ -6n(1 - \cos nt) & 0 & 0 & -2 \sin nt & 4 \cos nt - 3 & 0 \\ 0 & 0 & -n \sin nt & 0 & 0 & \cos nt \end{bmatrix} \begin{bmatrix} r_0 \\ i_0 \\ c_0 \\ \dot{r}_0 \\ \dot{i}_0 \\ \dot{c}_0 \end{bmatrix} \quad (3.3)$$

To propagate the model, the simulation utilizes a varied step propagator. The new position calculated by the state transition matrix becomes the current position. This process repeats for the duration of the simulation. Each spacecraft has its own propagation block.

3.3 Spacecraft Model

The spacecraft model is intentionally modular to allow for other spacecraft models to be substituted for experimentation purposes. There are a number of spacecraft parameters that may be of interest in a rendezvous scenario. The principal concern is the propulsion and attitude control system. The propulsion system dictates how quickly the spacecraft can change its orbit, while the attitude control system (ACS) dictates how quickly the spacecraft can change its direction of thrust. Given that many spacecraft have extremely quick ACS systems, it was decided to focus purely on thruster capability.

There are a number of parameters that change a satellites thrust capabilities, including

- *Thruster Force*– The maximum force that a thruster is capable of outputting dictates how quickly the spacecraft can change its velocity vector
- *Thruster Firing Delay*– Defines how quickly the thruster can fire again after it finishes a thrust impulse
- *ΔV per Firing*– Determines the maximum amount of time the thruster can fire for (and therefore the maximum impulse it can create)

These parameters are depicted visually in Figure 3.4. As a baseline, the two spacecraft are identical. Both have a maximum thrust of 0.001 N, a mass of 1 kg, and unlimited fuel reserves.

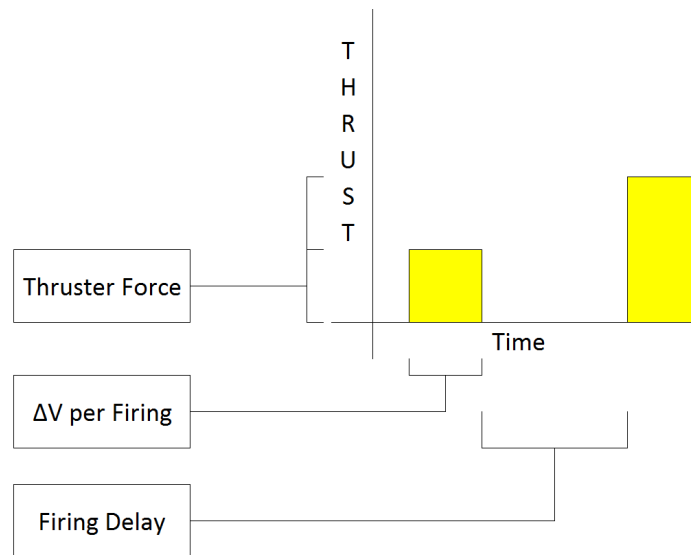

Figure 3.4. Visual depiction of spacecraft thrust parameters.

The spacecraft are assumed to only have one thruster that is vectored to provide thrust in a particular direction. Thus, the maximum thrust possible is constant regardless of the direction of thrust. Expenditure is therefore assumed to be 100% efficient – that is no thrust is wasted counteracting another thruster.

3.4 Model Integration

The fully integrated model must be able to take two spacecraft, starting with an initial separation vector, and allow them to apply tactics to maneuver around each other, subject to the limitations of their thrusters while tracking their respective fuel consumption.

In the developed model, each spacecraft is simulated separately on an identical timescale. Figure 3.5 shows a view of an isolated spacecraft. Three main components are visible, the tactics block, RPO model, and data output. The first component of each model is the tactics block, which takes the input of the states of the two spacecraft and provides the desired thrust output. The second component tracks fuel usage and manages the propagation of each spacecraft, while the final component provides the relevant outputs and checks victory conditions.

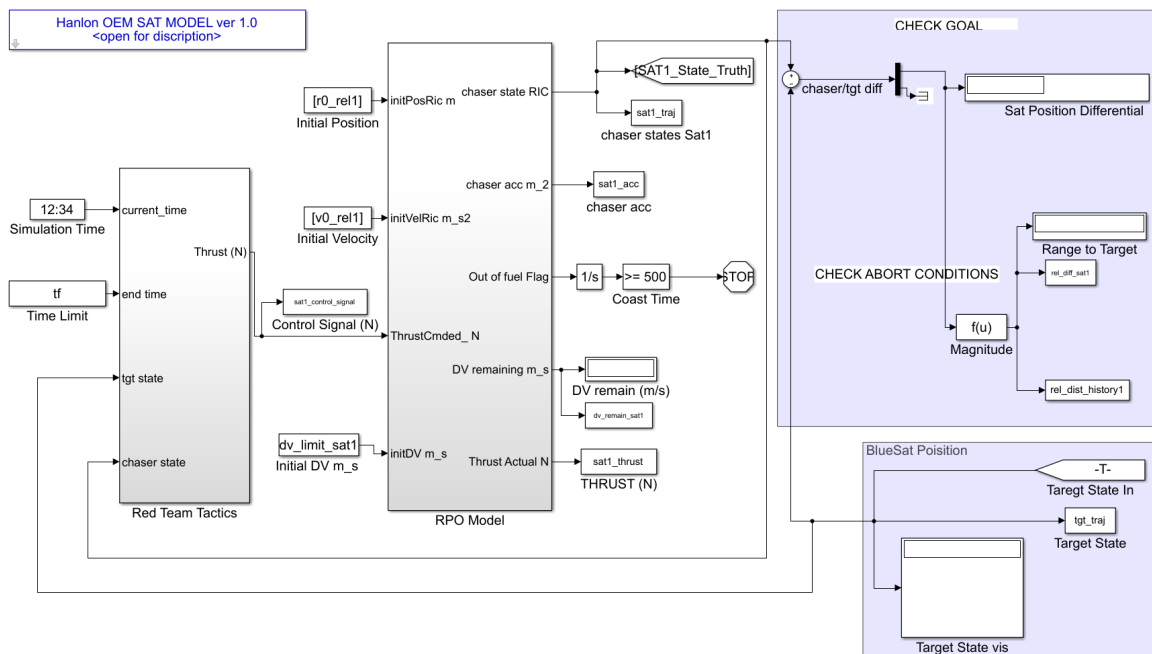

Figure 3.5. Spacecraft Simulink model.

3.4.1 Tactics Block

The tactics block, shown in Figure 3.6, takes the current configuration of the system (based on the two satellite states) and establishes what an appropriate response would be. Both spacecraft have unique Tactics Block based on the same inputs and outputs. A variety of tactics can be applied as circumstances dictate. Some tactics required knowledge of the expected rendezvous time. This parameter was shared between spacecraft as necessary. The inputs are time remaining, own state, and the other satellite state. The outputs are thrust commands.

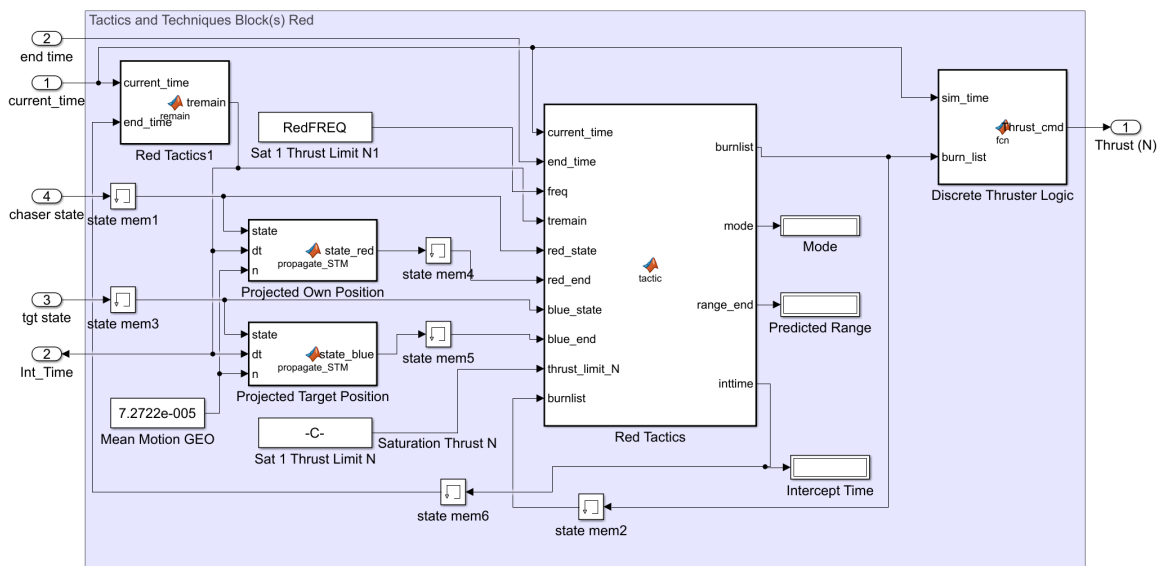

Figure 3.6. Spacecraft tactic blocks.

3.4.2 Proximity Operations Model

The proximity operations model serves two purposes. It translates the thrust commands generated by the tactics blocks into velocity changes and tracks the ΔV used. It also tracks the position and velocity of the spacecraft relative to the target's starting position and calculates what the state is in the next time-step.

The proximity operations model takes thrust input from the tactics block, input from Matlab for the initial starting condition. It outputs current state in the RIC frame and fuel used. Figure 3.7 shows the Simulink proximity operations model.

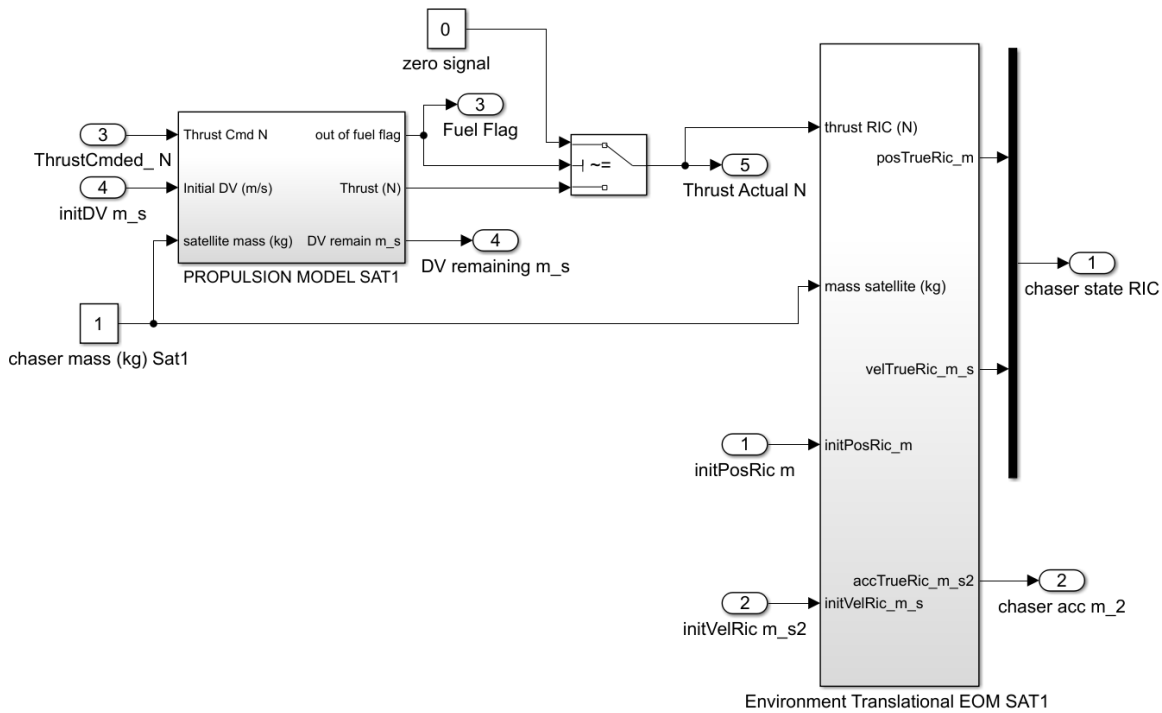

Figure 3.7. Spacecraft proximity operations block.

3.4.3 Model Output

The model is configured to take input from a spreadsheet design of experiment (DOE) to effectively test various parameter changes. The performance of the system is dependent on the tactics selected. Without well-developed tactics performance comparisons are meaningless. Chapter 5 provides a full explanation of the tactics development process.

The Simulink model outputs its results to the Matlab development environment. The two areas of interest are the thrust commanded and the spacecraft states as a function of time. From these outputs, a variety of other indicators can be calculated for further analysis.

Figures 3.8-3.11 present the main model output parameters. Specifically, Figure 3.8 shows a time history of the relative position of the two spacecraft. This plot is useful for evaluating their positions and the effect of their position on the engagement.

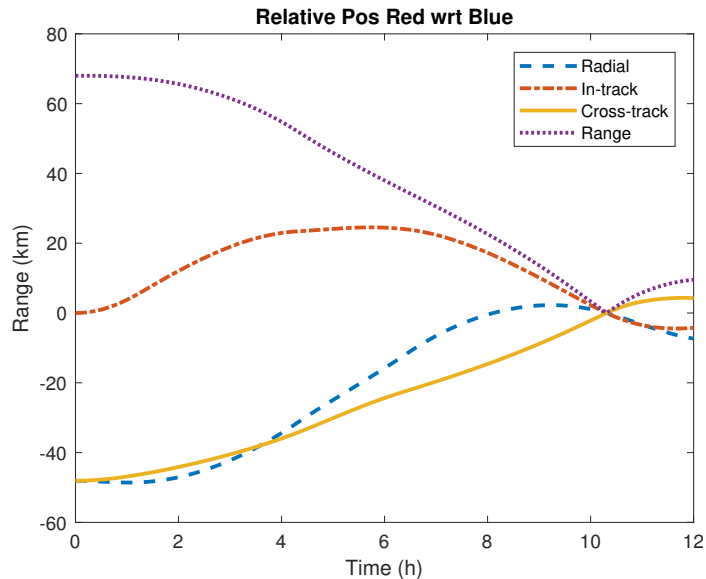

Figure 3.8. Example RIC coordinate time history

The RIC plot with stable origin (Figure 3.9) shows the overall movement of both spacecraft relative to Blue's starting point. This plot shows the net effect of the evasion thrust. Unlike the time history, this is relative to a constant position, not the two spacecraft which is necessary to understand the effects on the orbits.

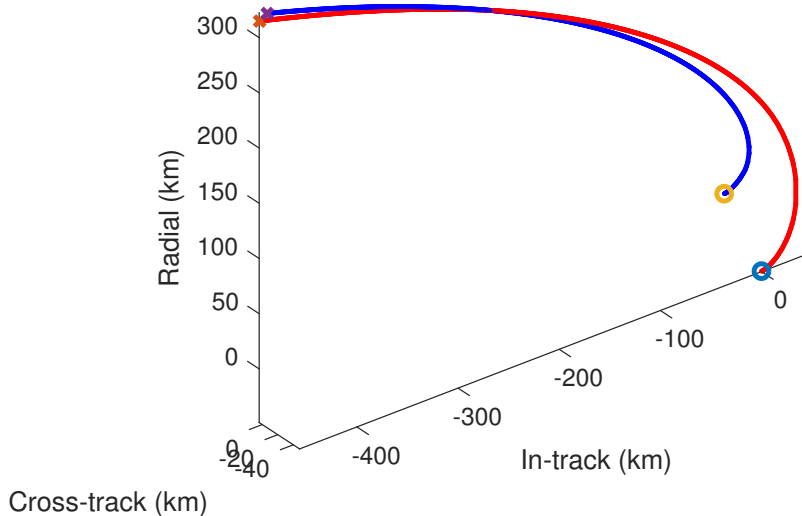

Figure 3.9. Example trajectory in RIC coordinates.

Figure 3.10 shows the ΔV commands each spacecraft executes. It shows a time history of the total fuel consumption. It can be used to assess what tactic each spacecraft is implementing,

and when used alongside the time history plot can show the effect of thrust.

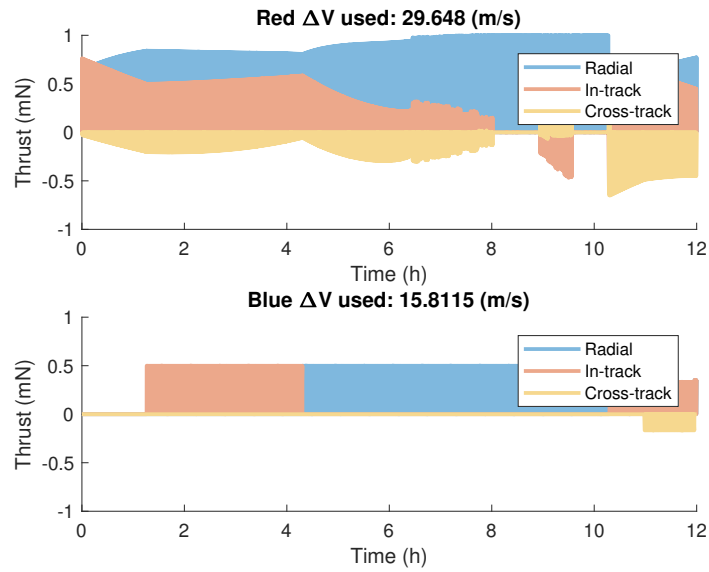

Figure 3.10. Example thrust command profiles for Red and Blue vehicles.

Finally, Figure 3.11 shows Red's intentions and the ΔV required to achieve this maneuver. It ultimately shows the effect of Blue's evasive maneuver. The more Red's intended intercept time needs to change, the more significant the effect of Blue's maneuver.

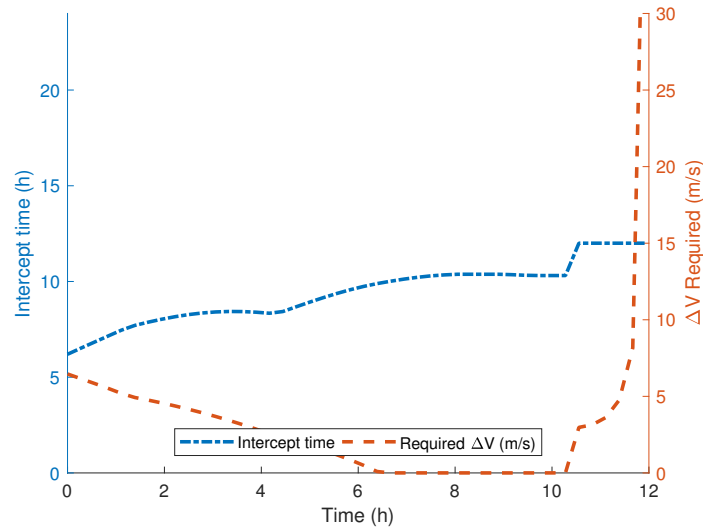

Figure 3.11. Example intercept data graphic.

3.5 Model Verification

A thorough model verification process was conducted to ensure that results are representative of real world orbital conditions. The simulation environment was compared to System Tool Kit's Astrogator propagator, which is a high-fidelity numerical propagation. Astrogator takes into account atmospheric conditions, radiation pressure, Earth's oblateness, solar and lunar gravitation effects, and gravitational resonance effects [30]. The developed Simulink model only accounts for earth's gravitation.

As shown in Figure 3.12, within the first orbital period, the simulations are remarkably similar. As time progresses, the model begins to diverge more. Thus, one orbital period is considered as a time limit to assure simulation results feasibility.

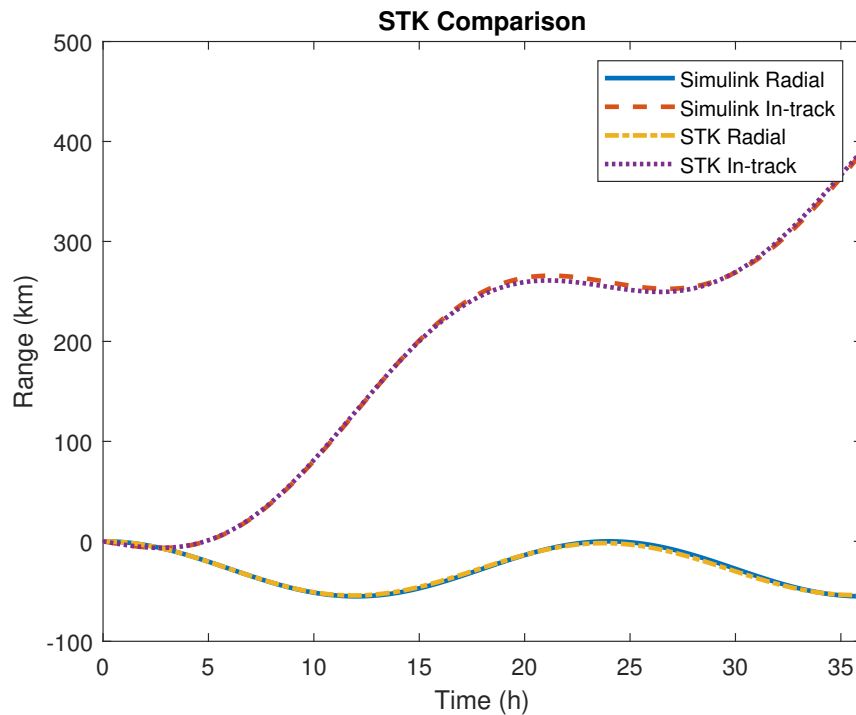

Figure 3.12. Comparison between STK Astrogator propagator and the Simulink model.

Summary

In response to the need to develop maneuver based defenses to co-orbital attacks, a Simulink model was developed using the *CW* equations to simulate co-orbital interactions and allow two spacecraft to “dogfight.” The model outputs four primary graphs that provide a visual representation of the engagement scenario. In comparisons with high-precision propagators, the model was demonstrated to provide similar performance over short time-spans (one orbit). Ultimately, the model allows for tactics development and verification across a variety of orbital conditions.

CHAPTER 4:

Mechanics of Space Engagements

This chapter provides a primer on space maneuver. It highlights what position of advantages are in space encounters, and discusses the effects of thrust application. Finally, it provides an overview of typical rendezvous trajectories.

4.1 Relative Motion in Orbit

As orbital dynamics govern motion in orbit, the Simulink model was used to assess the effects on operations. The results confirmed that Orbital maneuver does not match terrestrial movement or expectations. Orbital motion is heavily based on an objects position and velocity, while comparatively terrestrial maneuver is only based on velocity.

4.1.1 “At Rest”

Figure 4.1 shows the time history of an object initially placed at a position 10 km in the radial, in-track, and cross-track positions. It also shows the results for all positions combined.

Using the RIC frame and relative spacecraft position obfuscates the orbital mechanics of each position. When assigning objects locations relative to a point of interest (the point that defines the RIC frame) the only positions that are stable are those that only have an in-track component. Objects with in-track separation are at the same orbital altitude, with the same velocity, and with the same inclination. These objects will, therefore, remain in this state in perpetuity unless an external force is applied. This is shown in Figure 4.1.a.

An object initially positioned radially above the point of interest will not remain at that relative point. As the initial velocity matched the velocity of the point of interest, the object has the orbital velocity of a circular orbit below its own and therefore is actually in an ovalar orbit with an apogee of its starting location and a perigee of the object of interest orbit. As the semi-major axis of the orbit is longer, the object has a longer orbital period and therefore travels slower in the in-track direction as well, causing the object to lag the point of interest. This is shown in Figure 4.1.b.

An object positioned radially below the point of interest will have similar behavior, except it starts at perigee and climbs to an apogee at the orbital altitude of the point of interest. It travels faster in the in-track direction than the point of interest.

Objects initially positioned in the cross-track direction naturally oscillate between their starting location and its inverse, with a period equal to the orbital period. They maintain their in-track and radial positions, which means that any object directly positioned in a cross-track direction will impact the point of interest. These relationships continue to hold true when thrust is applied. This is shown in Figure 4.1.c.

Finally, Figure 4.1.d shows how objects positioned with radial, in-track and cross-track separation are dominated by their radial separation.

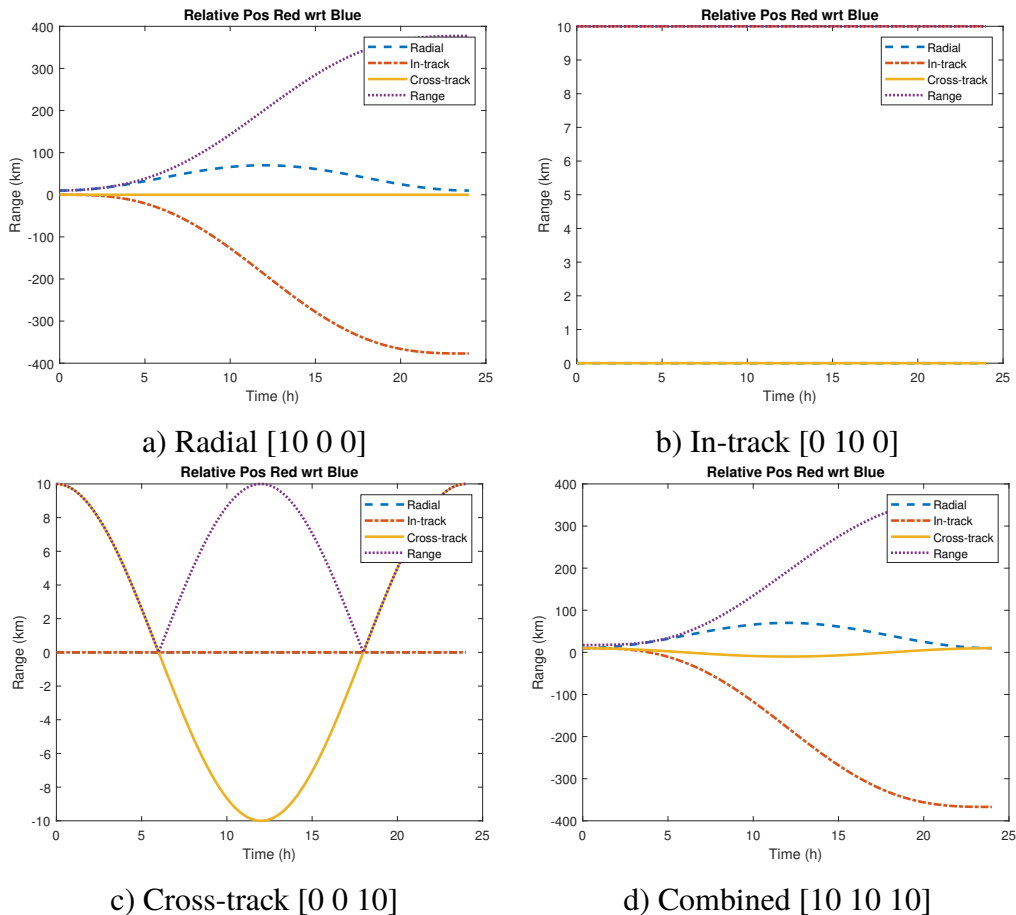

Figure 4.1. Time histories showing relative distance as a function of time based on various starting positions.

4.1.2 Thrust Application

Thrust application is dependent on the direction the thrust is initially applied.

Cross-Track thrust is entirely decoupled from in-track and radial thrust. As such, when cross-track thrust is applied, the spacecraft only moves in the cross-track direction (Figure 4.2). From an inertial reference frame perspective, cross-track thrust creates an inclination change. The nodes of the newly inclined orbit are located at the point the thrust was applied and the opposite side (50% period). If there is any cross track component to a position, it does not stay stationary and instead crosses the main orbit twice per orbital period. Figure 4.2 provides a visual representation of these relationships.

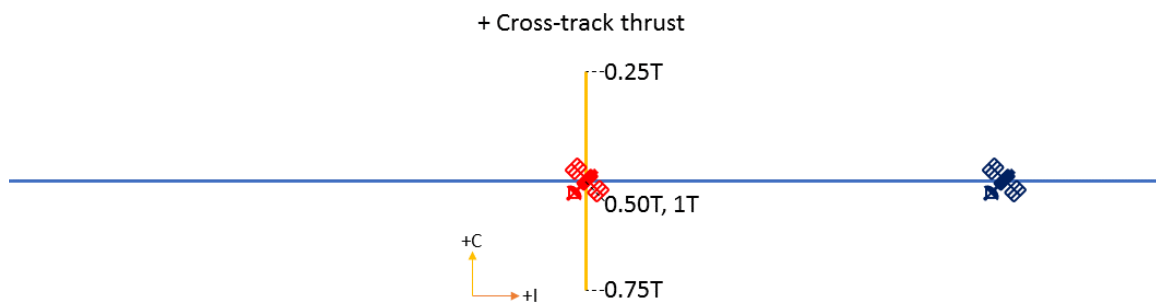

Figure 4.2. Effect of applying a positive cross-track thrust.

This figure shows the effect of applying positive cross-track thrust to a spacecraft. The black numbers indicate the time each location was reached, as a percentage of the original orbital period. The spacecraft remains in a circular orbit despite the thrust applied; the only change is to the inclination. For the first 25% of the period, the spacecraft moves in the +C direction. At 25% of the orbit, the largest separation is reached, and the cross-track component begins to decrease. At 50%, the spacecraft reaches its second node and the cross-track component becomes negative. This process repeats indefinitely and is identical each time. There is no notable thrust effect.

As seen from Equation 3.1, **radial and in-track** movement are cross-coupled. That means that thrust in either Radial or In-track directions results in radial and in-track movement.

Starting from a circular orbit, moving to a higher orbit (increasing radial position) results in a longer orbital period. This longer period is represented by negative in-track velocity in the RIC frame; effectively the spacecraft moves backwards from the reference point. Moving

to a lower orbit (decreasing radial position) results in a shorter period, which appears as a positive in-track velocity in the RIC frame.

As shown in Figure 4.3, thrust in the positive **radial direction** causes the spacecraft altitude to increase. Over the course of 25% of the period, that upward velocity converts to potential energy and the spacecraft reaches its orbital apogee. After 50% of the period, the spacecraft crosses over the reference orbit with a velocity that is the inverse of the initial velocity shift. At 75% of the period, the spacecraft reaches perigee, and after a full period, the spacecraft returns to its starting altitude. This cycle repeats indefinitely. Thrust in the negative radial direction creates the same effect, just reversed.

Figure 4.3 shows the effect of applying negative radial thrust (downward thrust) to a spacecraft on-orbit. The blue line is the orbit when no thrust is applied. The black numbers indicate the time each location was reached, as a percentage of the original orbital period. The thrust places the spacecraft in an elliptical orbit, with the first node at the starting point. For the first 25% of the period, the spacecraft moves in the +I, -R direction. At 25% of the orbit, the spacecraft reaches the perigee of its orbit, which is also the location of highest +I velocity. As the spacecraft begins to ascend, the +I velocity lowers. At 50%, the spacecraft reaches its second node and begins to ascend. As a result, the in-track velocity becomes negative, and the spacecraft returns to its starting location. This process repeats indefinitely and is identical each time. There is no notable thrust effect.

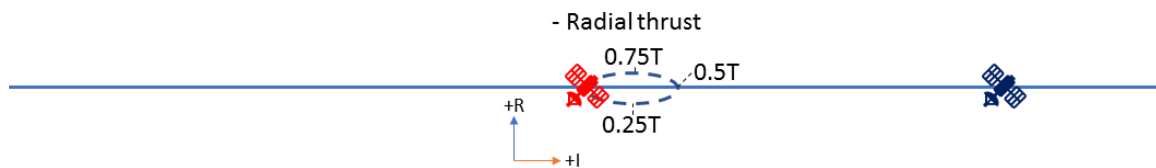

Figure 4.3. Effect of applying negative radial thrust.

Thrust in the positive **in-track** direction (Figure 4.4) increases orbital velocity and therefore creates an elliptical orbit with a perigee at the point the thrust was applied (Figure 4.4). This orbit results in the spacecraft ascending radially for 50% of the orbital period, before descending to the starting altitude after a full period. Thrust in the negative in-track direction produces the opposite effect; the spacecraft loses orbital velocity and enters an elliptical orbit with an apogee at the point the thrust was applied. It reaches perigee after 50% of the orbital period and returns to its starting altitude after a full period. Both are stable

configurations; the rise/fall continues indefinitely.

Figure 4.4 shows the effect of applying positive in-track thrust (thrust to the right) to a spacecraft on-orbit. The blue line is the orbit when no thrust is applied. The black numbers indicate the time each location was reached, as a percentage of the original orbital period. The thrust places the spacecraft in an elliptical orbit, with the perigee at the starting point. For the first 15% of the period, the spacecraft moves in the +I, +R direction. After this point, the higher orbital altitude results in a longer orbital period and thus a lower in-track velocity, which results in the spacecraft reversing direction to move in the -I direction. After 50% of the orbit, the spacecraft reaches the apogee of its orbit. The apogee is also the location of highest -I velocity. As the spacecraft begins to descend, the -I velocity lowers. After one period, the spacecraft begins ascending again, and the -I velocity increases again. This process repeats indefinitely. Note that the +I motion only occurs immediately following the thrust application – it does not repeat.

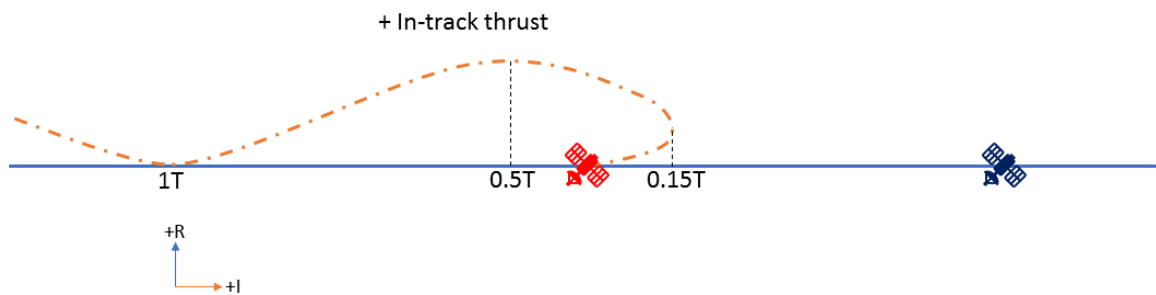

Figure 4.4. Effect of applying positive in-track thrust.

Thrust in the in-track direction produces a much larger overall displacement in both the radial and in-track direction. The increase in radial displacement is driven by the point thrust applied. In the radial thrust example, the spacecraft applies thrust at a node vice at perigee or apogee. Applying thrust at the node divides the effect of the thrust into a decrease in perigee and an increase in apogee, which accounts for part of the displacement difference. The remainder is accounted for by the shape of the orbit. The orbit created using radial thrust is more circular than the orbit created by the in-track thrust, which results in lower extrema but the same average energy state.

While both produce the same net effect, changing orbit by firing in the radial direction is less efficient than by firing in the in-track direction. This situation is depicted in Figure

4.5. This figure shows the effect of equal magnitude thrusts in the \pm in-track and \pm radial directions. While the radial and in-track components are not the same scale, all elements retain the same proportionality.

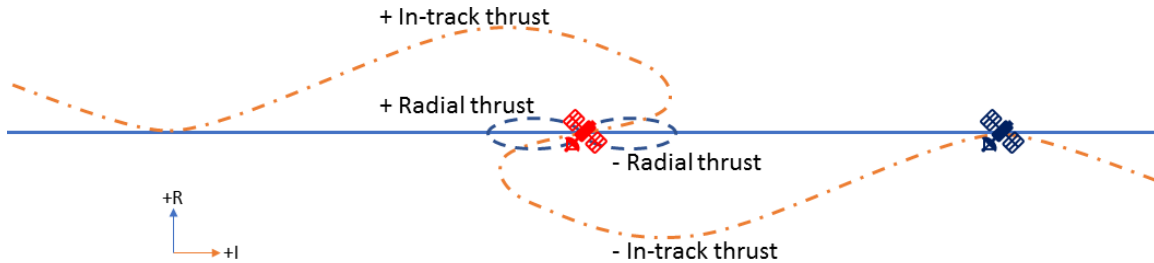

Figure 4.5. Effect of thrust application.

It is of note that the in-track thrust application moves initially in the direction the spacecraft applies thrust before reversing course after 15% of an orbital period. Depending on the timing of the event the spacecraft is trying to effect, it may be more efficient to use a different thrust direction.

4.2 Maneuver Basics

The most basic form of proximity operations uses single orbit transfers to move from point to point on a circular orbit. To plan a maneuver, the spacecraft must know its position and its target position, relative to the same RIC frame. The spacecraft then selects the time it would like to spend in transit between those two locations and uses CW equations to determine what velocity state it must have to achieve the desired endstate (Figure 4.6). Comparing the desired velocity to the actual velocity produces the necessary thrust burn.

$$\begin{bmatrix} r \\ i \\ c \\ \dot{r} \\ \dot{i} \\ \dot{c} \end{bmatrix} = \begin{bmatrix} 4 - 3 \cos nt & 0 & 0 & \frac{1}{n} \sin nt & \frac{2}{n}(1 - \cos nt) & 0 \\ 6(\sin nt - nt) & 1 & 0 & -\frac{2}{n}(1 - \cos nt) & \frac{1}{n}(4 \sin nt - 3nt) & 0 \\ 0 & 0 & \cos nt & 0 & 0 & \frac{1}{n} \sin nt \\ 3n \sin nt & 0 & 0 & \cos nt & 2 \sin nt & 0 \\ -6n(1 - \cos nt) & 0 & 0 & -2 \sin nt & 4 \cos nt - 3 & 0 \\ 0 & 0 & -n \sin nt & 0 & 0 & \cos nt \end{bmatrix} \begin{bmatrix} r_0 \\ i_0 \\ c_0 \\ \dot{r}_0 \\ \dot{i}_0 \\ \dot{c}_0 \end{bmatrix}$$

Desired Endpoint Starting Point Solve for Velocity

Figure 4.6. Schematics of ΔV calculations.

After this calculated thrust is applied, the spacecraft enters a new orbit. This new orbit results in an intercept with the target coordinates. If the intention is to stop at the target point, an additional burn must be completed upon arrival to match the appropriate state velocities.

4.3 Maneuver Difficulty

Unlike terrestrial maneuvering, the level of effort (ΔV) required to maneuver between points in space is not directly dependent on the range between the points. Instead, the difficulty is cyclically time dependent based on orbital dynamics. Depending on the starting positions relative to a common circular orbit, rendezvous may occur or be made easier due to natural orbital motion, or it may be complicated.

Ultimately, maneuvering to specific coordinates in space is dependent on the amount of time allocated to reach each point. As orbital dynamics govern all maneuvers, the ability to rendezvous is, in many cases, periodic. When evaluating an intercept maneuver, the two principal considerations are as follows:

1. *Maneuver Cost*– Maneuver cost is normally fuel driven. Spacecraft must be launched with all of their fuel onboard; as of yet no effective refueling method exists. Given this constraint, mission life tends to be fuel limited. Any opportunity to reduce fuel consumption maximizes the spacecraft’s operational life.
2. *Time Enroute*– The second facet of maneuver is the time to intercept. The criticality of this parameter is dependent on outside factors. If there is a military or political need to accomplish a mission within a certain window, then time en route may be the deciding factor in maneuver planning. If there is some flexibility in the timing, then more efficient routes can be chosen to minimize fuel.

The difficulty as measured by ΔV to reach a point is varies based on the time to intercept and the plane in which the maneuver is occurring. Figure 4.7 shows the difficulty for a spacecraft to reach a point initially 50 km away in each direction.

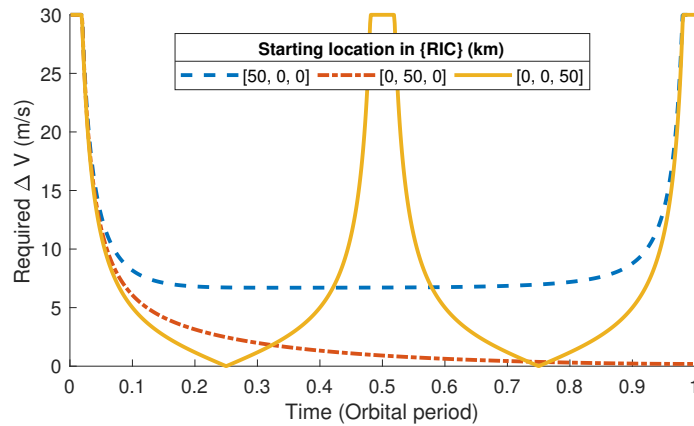

Figure 4.7. ΔV computed based on time of intercept.

Maneuvers in the **cross-track** plane are the most straightforward. Thrust applied in the cross-track direction results in an inclination change. Regardless of the magnitude of thrust imparted, the newly inclined orbit crosses the original orbit twice every orbital period, as the spacecraft transitions from positive cross-track displacement to negative displacement. The lowest cost intercept for an object that has existing cross-track separation is to simply wait for the orbits to cross naturally, which occurs within the next 0.5 periods. In Figure 4.7, where the spacecraft begins 50 km cross-track from its target point with no initial cross-track velocity (highest cross-track displacement), no thrust is required to intercept in 0.25 or 0.75 periods. Intercepting in 0.5 periods takes an exceptionally high amount of thrust as this would require circularizing the orbit completely.

If there is initially a **radial** separation between present and target location, there is a minimum amount of energy required to initiate an intercept. If the orbits naturally cross, the required ΔV is low as the only adjustments necessary are orbital phasing. If the orbits do not cross, sufficient energy must be input to adjust appropriately.

In-track maneuvers, where both spacecraft begin in the same circular maneuvers, are very inexpensive. It only takes a minor amount of thrust to enter an orbit slightly higher or lower to initiate a phasing maneuver to catch up to an objective point. The required ΔV is entirely dependent on the speed of the desired rendezvous; it can be any non-zero value provided the interceptor is willing to wait long enough to eventually intercept.

Figure 4.8 shows the required ΔV required to reach points relative to the starting location

at 0,0 in a circular orbit with a variety of timesteps. It color maps level of effort to reach points from 0,0. Blue requires relatively low effort; yellow requires the most effort. As the available time increases, the difficulty to move to points in-track decreases. Note how for maneuvers in less than 12.5% period, the relative difficulty is very nearly purely range-based. As the available time increases, the difficulty to reach locations in the in-track direction decreases.

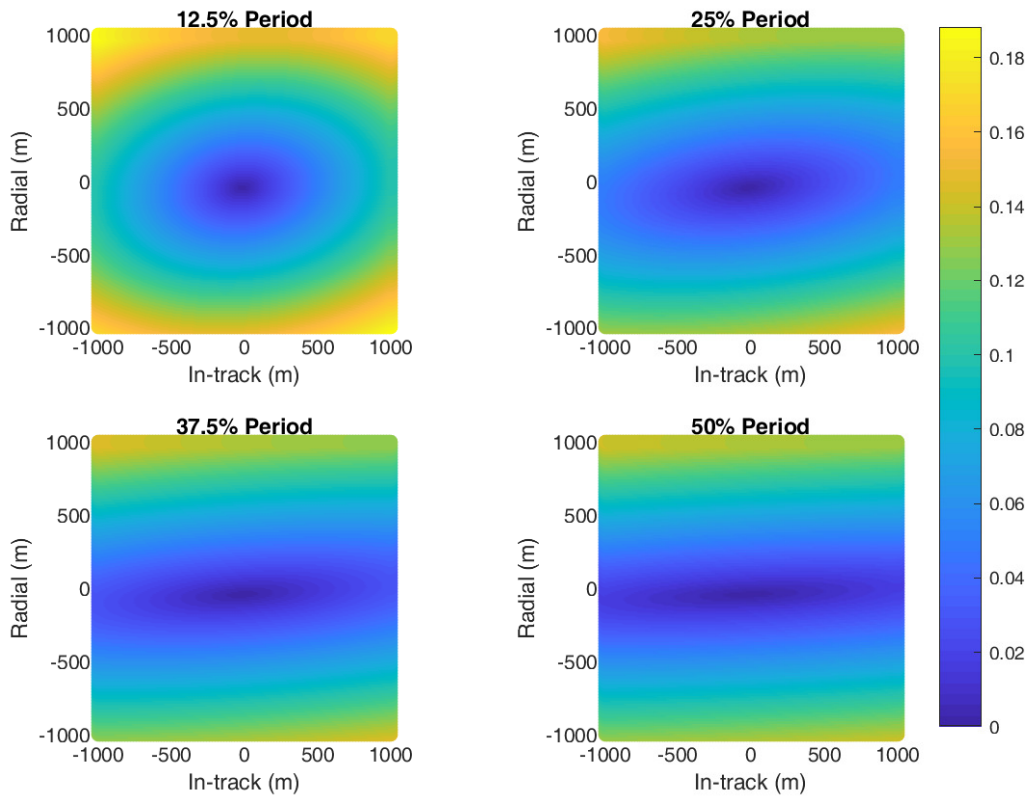

Figure 4.8. Depiction of ease of transit (reachability).

4.4 Threat Classification and Triggers

Terrestrial assets typically use range based exclusion and warning zones to determine what objects are threats and dictate an appropriate response. These are typically defined based on the range to the high-value asset and are spaced such that there is sufficient time to respond to the worst case threat.

As space becomes a war-fighting domain, similar schemes must be set up for spacecraft. The challenge is establishing what form of perimeter is appropriate. The goal of the triggering system is to ensure the spacecraft has sufficient time to respond to an inbound threat. Currently, most spacecraft do not have defensive weaponry and therefore are limited to evasive maneuvers in response to aggression.

Ground-based units may be able to assist; however, spacecraft in the GEO belt are hours away from ground-launched assets. Diplomacy may be able to assist, but such interactions take time. Ultimately, the triggering range for evasive maneuver should be set such that the on-orbit asset is able to survive long enough to be rescued; either by the diplomatic process or by ground-launched interceptors. This research uses 24 hours as a working estimate.

As the defensive operation is maneuver based, the triggering system should take into account the level of effort necessary for the aggressor to approach within a set time limit. If the level of effort drops below a certain threshold value, the defender should begin evasive maneuvers. This initial effort required provides a maneuvering advantage for the evasion; the adversary must both provide the effort to rendezvous with where the target was, and any additional movement generated by the targets maneuvers. In this thesis, 5 m/s ΔV was selected as the threshold value. If the effort required to complete an intercept dropped below this value, the defender would maneuver. The desired time of intercept needs to be accounted for when determining maneuver effort. For this research, that desired intercept was four hours.

Figure 4.9 shows the warning area for a 6-hour intercept in Radial and In-track components for objects that are stationary relative to the target. Figure 4.10 shows the same warning area in the Cross-track and In-track components. Note how for a six-hour intercept, cross track range has no bearing as starting in the initial cross-track position naturally results in an intercept within six hours. This relative ease of intercept illustrates how range-based solutions are inadequate to estimate threat.

In summary, the proposed method to evaluate whether or not a nearby object is a threat to the defending spacecraft is to evaluate the aggressors ΔV requirements for an intercept within a certain defensible threat time. If that value is assessed to be larger than a threshold value (perhaps driven by the magnitude of previous enemy maneuvers), the object won't be a threat in that time window.

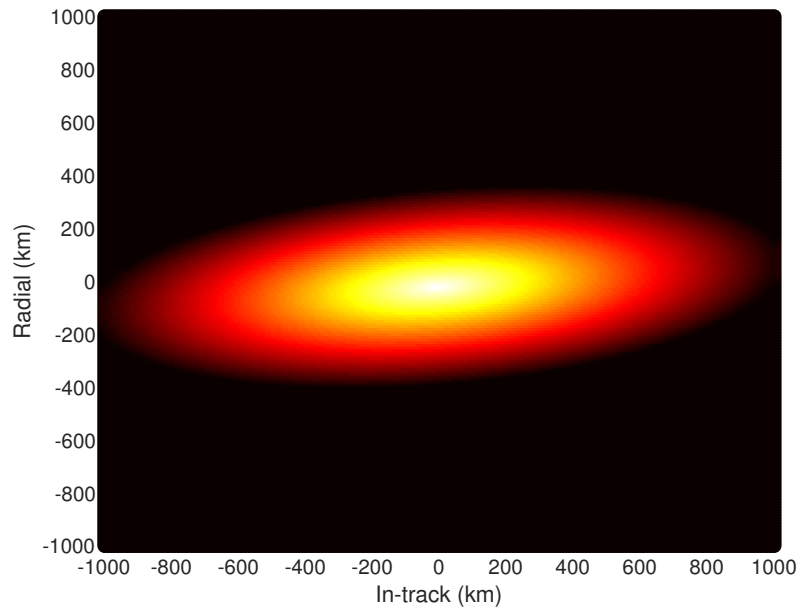

Figure 4.9. Radial and in-track threat envelope for a six-hour intercept.

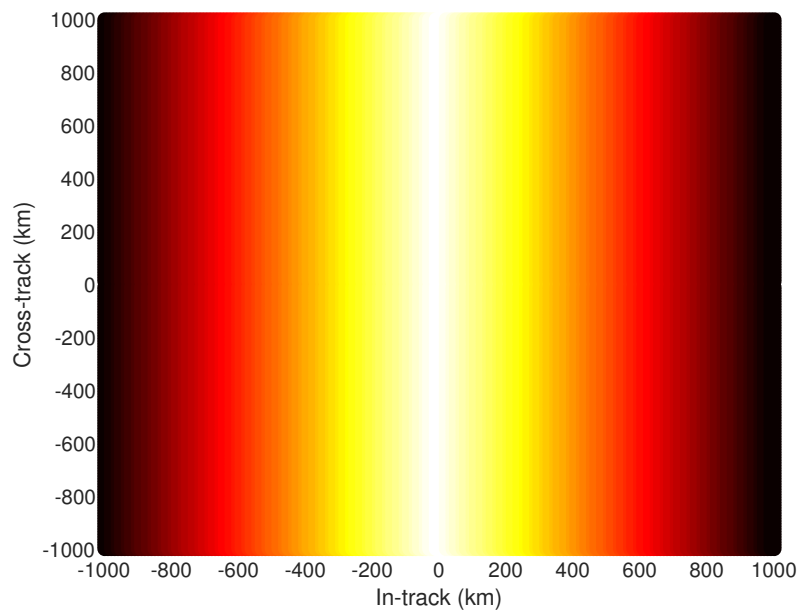

Figure 4.10. Cross-track and in-track threat envelope for a six-hour intercept.

Summary

The Simulink model confirmed that space maneuver is very different than terrestrial maneuver. On-orbit, there is no direct correlation between range and difficulty of rendezvous. Cross-track displacement naturally crosses the orbital path twice per orbit. Radial displacement may also have a periodic relationship. These relationships may be used to either the aggressor or defenders advantage, but only if they are taken into account. Threats must be categorized based on the difficulty of rendezvous instead of range, which provides a more accurate estimate of threat likelihood and affords the defending spacecraft the opportunity to react appropriately.

CHAPTER 5: Tactics Development

This chapter looks at the development of an evasive maneuver tactic that aims to minimize the defender's fuel consumption while maximizing the aggressor's fuel consumption. It begins by examining the effects of thrusting in different directions, then identifies a control scheme to integrate the best performance and minimize the evader's fuel consumption.

5.1 Direction Tests

The first objective was to determine the best overall thrust direction. This process was completed using a constant thrust model. The intent was to determine the best direction to apply thrust based on the starting position of an attacker intent on rendezvous.

5.1.1 Configuration

The process was simulated in the model described in Chapter 3. The aggressor spacecraft is referred to as the "Red" spacecraft, while the defender/evader is the "Blue" spacecraft. Both spacecraft are identical. Between tests, the starting position and flee direction were varied.

Flee Direction The flee direction is the direction in which the blue spacecraft applied thrust. Twenty-six different directions were examined for each starting position, representing a sphere subdivided into 45rcs. This is shown in Figure 5.1.

Starting Position The same 26 directions were the starting locations. However, while the flee direction is just a vector, the starting position has a starting range associated with it. The starting range chosen was selected by normalizing the required ΔV for intercept within 4 hours to 7 m/s. That is, for Red to intercept a non-evading Blue from the starting position in four hours, it would expend exactly 7 m/s ΔV . This normalization aided in the comparison of results between starting positions. This matches expected performance based on a triggering system similar to the one described in Chapter 4. Figure 5.2 shows the calculated starting positions.

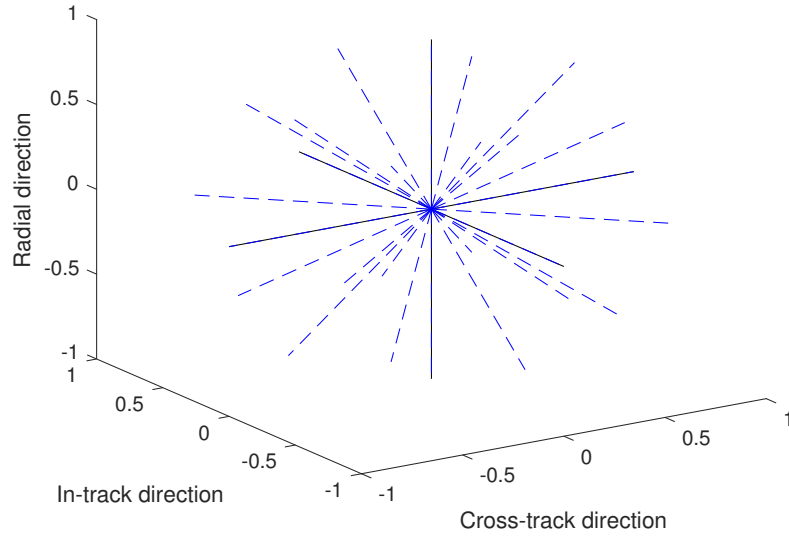

Figure 5.1. Tested evasion thrust directions.

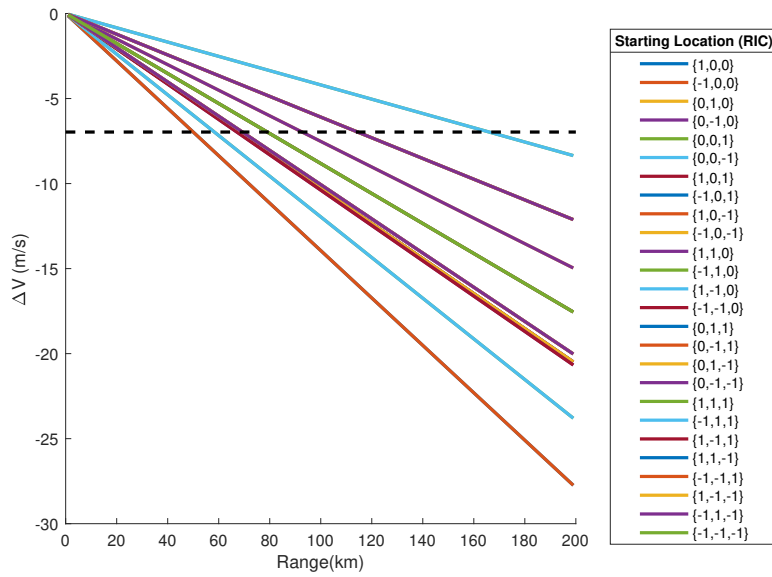

Figure 5.2. Cost of four-hour intercept vs. range.

Duration The duration of the simulation was set to 24 hours (one period). This scenario length was chosen because it allows for the full orbital regime to be tested. Furthermore, considering geopolitical events, any attack that takes longer than 24 hours can doubtlessly be responded to or prevented through terrestrial means.

Information Both Red and Blue have full state knowledge of the other spacecraft.

5.1.2 Tactic Applied

Red’s objective is to rendezvous with Blue within 24 hours of the simulation start time while expending the minimum ΔV . To determine this trajectory, every time-step, Red takes its current position and Blue’s position and calculates the necessary velocity change to intercept within the simulation window. To ensure it is on the most effective route, it scans the remaining simulation time for the lowest cost intercept and executes that trajectory. In some cases, Red intercepts Blue before the simulation window ends.

Blue fires its thruster in the same direction in the RIC frame for the duration of the simulation.

These tactics are summarized in Figure 5.3

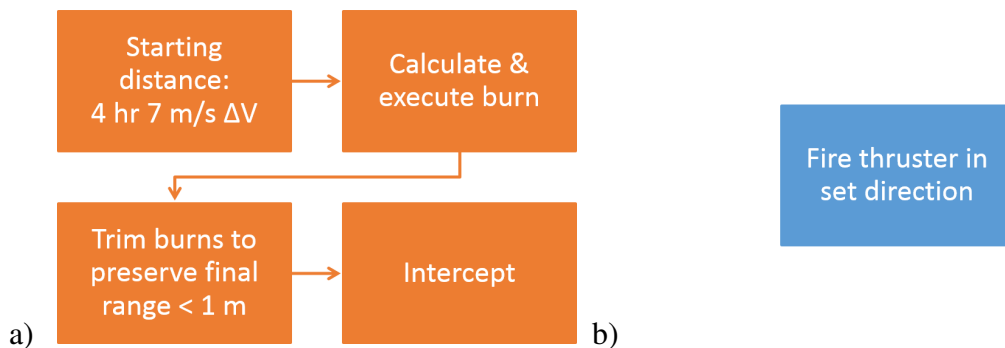

Figure 5.3. Red aggressor tactic (a), and Blue constant thrust tactic (b).

5.1.3 Success Criteria

Two elements determine Blue’s success

- *Minimum Range*– Prevent Red from approaching within 1 km in the 24-hour simulation window.

- *End Cost*– Distinguishes between trials with successful evasions. The most successful evasion methods result in the largest separation between the two spacecraft, where separation is measured based on rendezvous cost, not distance. Rendezvous cost is calculated as the cost of an intercept within four hours, assuming no Blue maneuver.

The first criteria, avoid intercept, is pass/fail. The second criteria, end cost, results in a calculated ΔV value where higher is better.

5.1.4 Simulation Results

The simulation showed clear differences between thrust directions. In almost all cases, thrust in the radial direction provided the most separation at the end of the simulation. Figure 5.4 shows the cost of a four-hour intercept at the conclusion of simulation, based on the evasion maneuver selected. For 22 of the 26 cases, evading in the in-track direction is shown to be most successful.

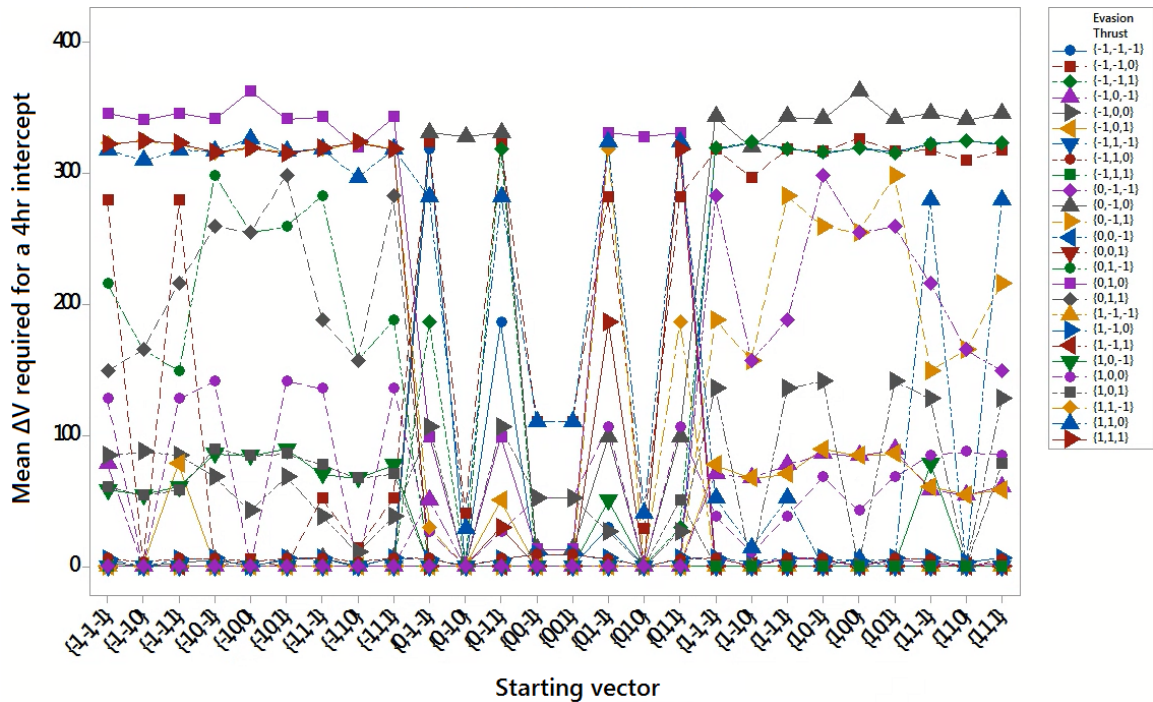

Figure 5.4. Cost of four-hour intercept after evasion in various directions.

In-track Evasion

Firing the thruster in-track is the most efficient in nearly all cases. This efficiency is primarily because thrust in-track has the most significant effect on the shape of the orbit, and therefore provides the most dramatic change for a given ΔV input.

An example case compares a no-maneuver scenario and an in-track scenario where the pursuer begins behind and below $\{-1,-1,0\}$. From this starting location, the natural movement of the pursuer is in the positive in-track, positive radial direction – i.e., toward the Blue spacecraft. As Red has the same starting velocity of Blue, it starts in an ovalar orbit with perigee at $t = 0$ and apogee at $t = 12\text{h}$. The apogee is without any Red thrust. It reaches the same orbital altitude of Blue at $t = 12\text{h}$ before it begins to descend again.

Red's initial maneuver assumes that Blue does not maneuver. Red opts for the minimum ΔV maneuver that results in an intercept and burns 6.5 m/s in the positive in-track direction to raise its orbit to allow for appropriate radial and cross-track positioning. This maneuver provides sufficient time to both raise the orbit and catch up to Blue and results in an intercept around $t = 20\text{ hrs}$. Figure 5.5a illustrates this pattern.

When Blue is allowed to evade, the most efficient single-direction evasion is an in-track burn. In this case, it is best to fire the thruster away from the pursuer (adding velocity in the radial direction), which ultimately causes a higher orbit with a slower relative radial velocity that results in Red overshooting Blue while it is still below. The radial separation between the spacecraft remains, which ensures that Red cannot catch up.

Ultimately, Red ends up so far below and ahead of Blue that it would require 340 m/s ΔV to complete the rendezvous within four hours at the end of the simulation. The closest point of approach is 69 km , the starting location.

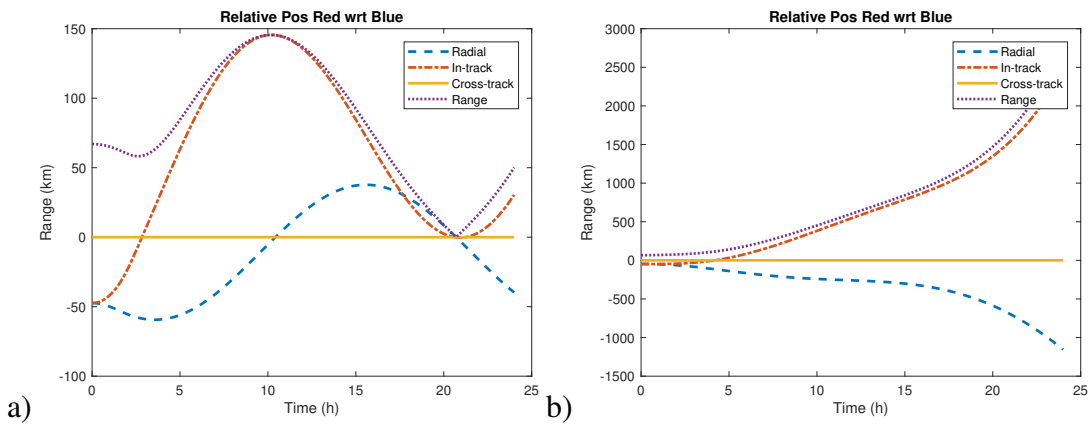

Figure 5.5. Position vs time without Blue maneuver (a), and with continuous in-track Blue maneuver (b). NOTE: different axis.

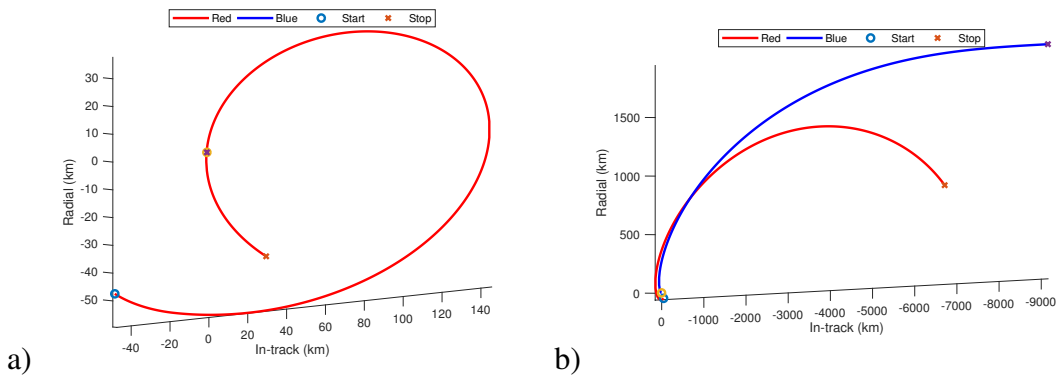

Figure 5.6. Relative position of spacecraft without Blue maneuver (a), and with continuous in-track Blue maneuver (b). NOTE: different axis.

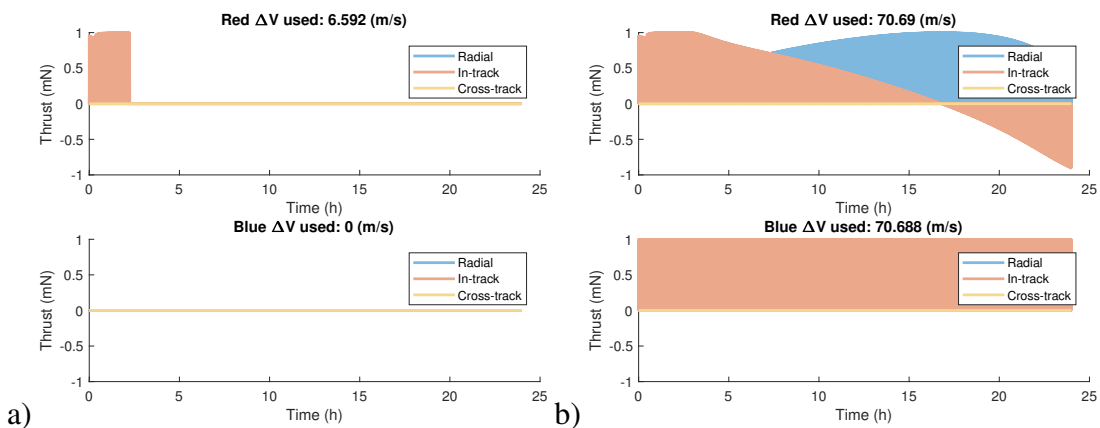

Figure 5.7. Thrust profiles without Blue maneuver (a), and with continuous in-track Blue maneuver (b).

Radial+In-track Evasion

There are some cases where in-track evasion alone is ineffective. This occurs when Red is already in a time-bound zero-thrust trajectory, which is most notable as a cross-track approach ($\{0,0,1\}$ & $\{0,0,-1\}$). The cross track starting position means that the red spacecraft would naturally rendezvous after six hours. As Red does not require any thrust to rendezvous, all of its thrust is available to match Blue's maneuver, which renders in-track thrust ineffective as both spacecraft can chase each-other indefinitely. In-track thrust results in a mere 11 m/s 4-hour ΔV at the end of the simulation.

By adding a radial component to the thrust, Blue changes the optimal rendezvous time and ensures that the orbits do not cross. Figure 5.10 shows the intended intercept time and the ΔV necessary to achieve it assuming Blue stops maneuvering. Note how the radial + in-track evasion (right) forces the intercept time change earlier, resulting in a less efficient red pursuit. This crossing thrust is the most difficult for the pursuer to mimic as it attempts to rendezvous. This thrust direction is highlighted in Figure 5.9.

Figure 5.8 shows the relative positions over the entire engagement. It is of note that the best thruster performance only achieves a 360 meter separation at the initial intercept (six hour) point. This separation is the largest generated by any firing direction. Ultimately, a spacecraft should not be allowed to be positioned in this starting position as it is a nearly indefensible position.

All Direction Evasion

There is one additional case where affecting the intercept time results in a less efficient Red intercept attempt. If the pursuing spacecraft is above and behind ($\{1,-1,0\}$), it is actually moving away from its target in the in-track direction. The "natural" (minimum ΔV) rendezvous time in this state is around 20 hours. By introducing Blue cross-track thrust, that optimal rendezvous point changes, as the Blue spacecraft will have a cross-track element to its position at all times not equal to $t=12h$ and $t=24h$. Red calculates that it is now more efficient to rendezvous sooner and chases Blue in the cross-track direction. It intends to rendezvous within 15% of the orbit, and as a result, uses less effective thrust patterns (firing radially). As Blue continue to evade, the intercept time increases, meaning that Red uses inefficient maneuver for the majority of its engagement. This relationship is shown in Figures 5.11, 5.12 and 5.13.

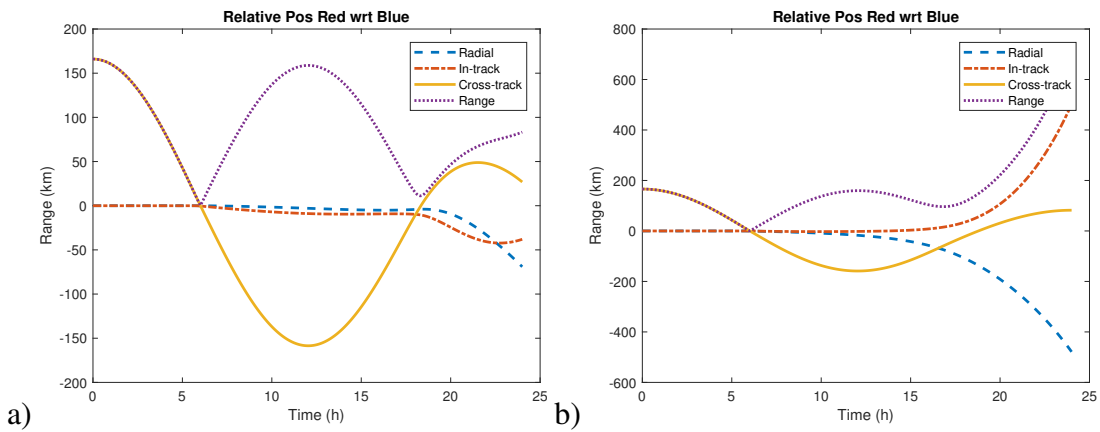

Figure 5.8. Position vs time for in-track evasion (a), and radial and in-track evasion (b).

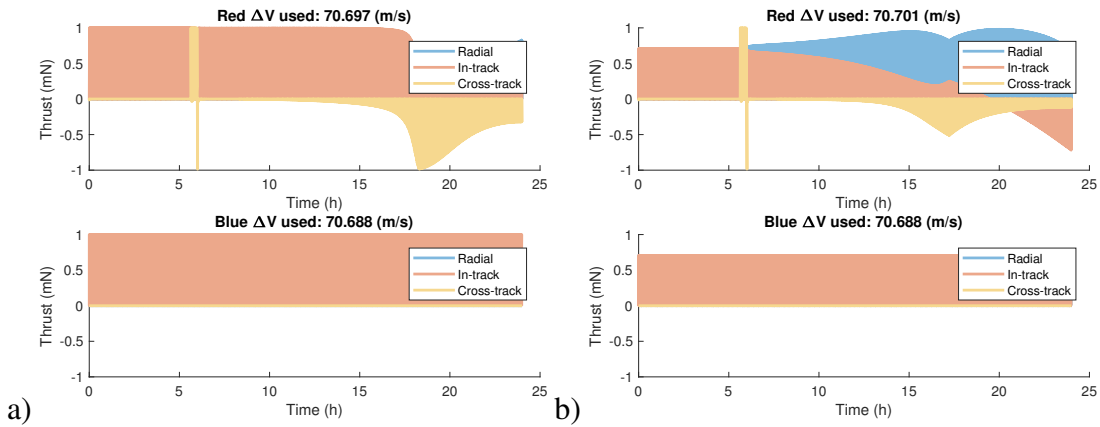

Figure 5.9. Thrust profiles for in-track evasion (a), and radial and in-track evasion (b).

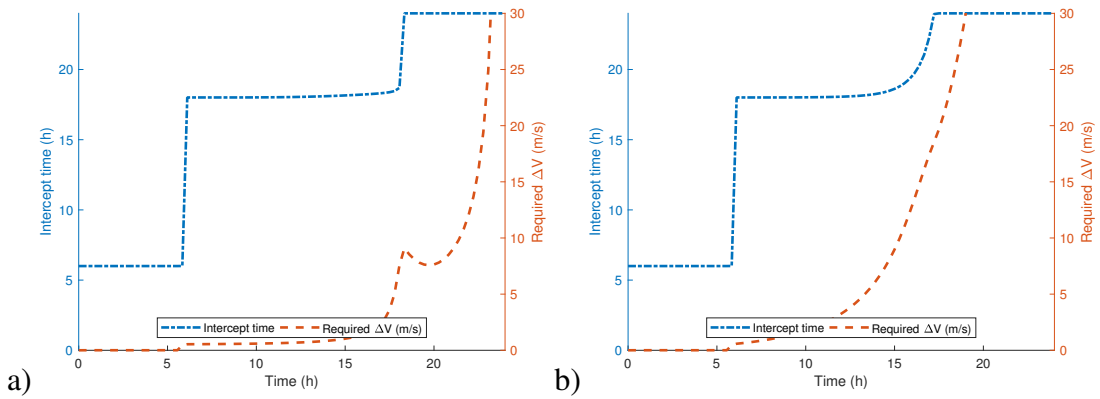

Figure 5.10. Time/intercept profiles for in-track evasion (a), and radial and in-track evasion (b).

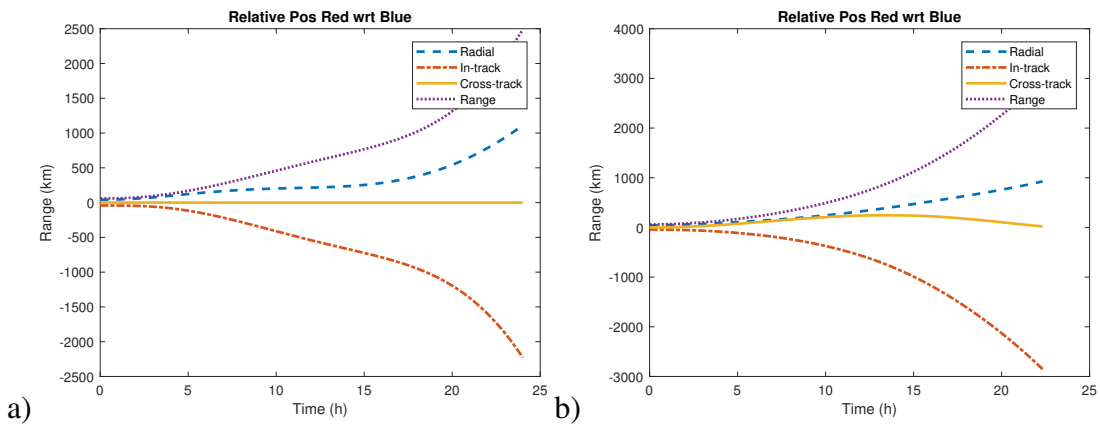

Figure 5.11. Position vs time for in-track evasion (a), and radial, in-track and cross-track evasion (b).

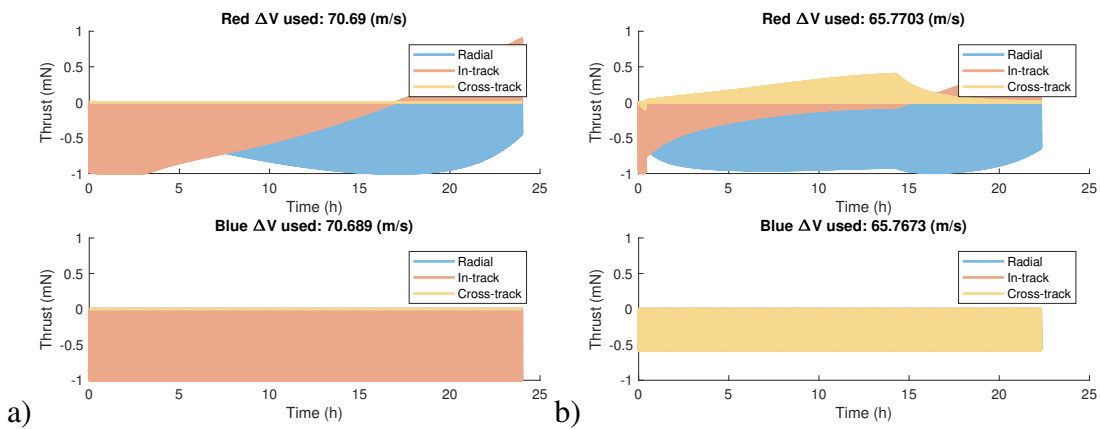

Figure 5.12. Thrust profiles for in-track evasion (a), and radial, in-track and cross-track evasion (b).

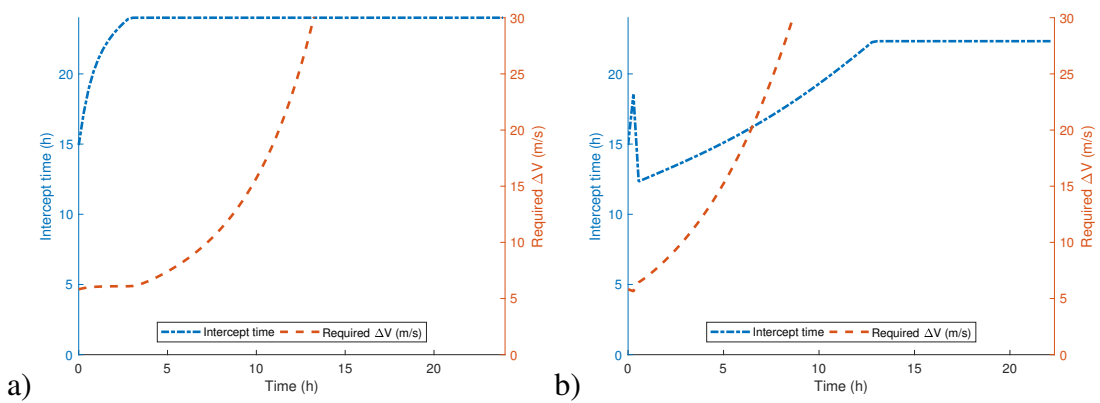

Figure 5.13. Time/intercept profiles for in-track evasion (a) and radial, in-track and cross-track evasion (b).

5.2 Minimum- ΔV

All of the evasion patterns examined using the continuous thrust controller resulted in “excessive” evasions, where Blue ended up well beyond Red’s position. While this excess capacity may be necessary if the exact positioning of the spacecraft is unknown, it is otherwise a waste of fuel. As most spacecraft are both dependent on having fuel and are unable to be refueled, fuel is a critical resource. As such, fuel expenditure must be minimized for each engagement while maintaining appropriate separation. A controller was developed to trigger thrust burns only when necessary.

5.2.1 Starting Configuration

The minimum- ΔV controller was tested using the same 26 different starting positions shown in Figure 5.1. A 24-hour simulation time was selected to match the constant-thrust scenarios.

5.2.2 Control Logic

The red spacecraft attempts to rendezvous using the same controller used in the single-direction tests.

There are four elements to the blue spacecraft control system

1. *Forecaster*– To determine if the spacecraft is under threat, and therefore the state of the trigger, Blue must know how difficult it would be for Red to rendezvous. To determine this state, Blue applies Red’s rendezvous logic to the two spacecraft’s state, and evaluates the remaining simulation time to assess Red’s needed ΔV .
2. *Trigger*– The trigger determines when Blue fires the thruster. Blue fires the thruster based on the difficulty of Red’s rendezvous. To determine this state, Blue uses the *forecaster*.
3. *Thrust Direction*– As this proved most universally applicable, in the constant thrust examples, the thrust will either be in the positive or negative in-track direction. This determination is made based on the results of the constant thrust tests.
 - *Radial*– If Red is above Blue, Blue applies negative thrust to slow and move to a lower orbit. If Red is below Blue, Blue does the opposite.
 - *In-track*– If Red is even with Blue radially but has an in-track displacement, Blue thrusts towards Red.

- *Cross-Track*– If Red has no in-track or radial separation and is only displaced in the cross-track axis, Blue thrusts away from Red.

After Blue makes the initial maneuver determination, the direction of thrust is fixed in that direction to avoid inefficient reversals.

4. *ΔV per Thrust*– Blue determines the ΔV per thrust (thrust pulse duration) based on the magnitude of Red’s rendezvous ΔV requirement as compared to the threshold. Mathematically, this is: $\Delta V_{Blue} = \text{Threshold} - \Delta V_{RedReq}$

Figure 5.14 provides a flow chart representation of these tactics.

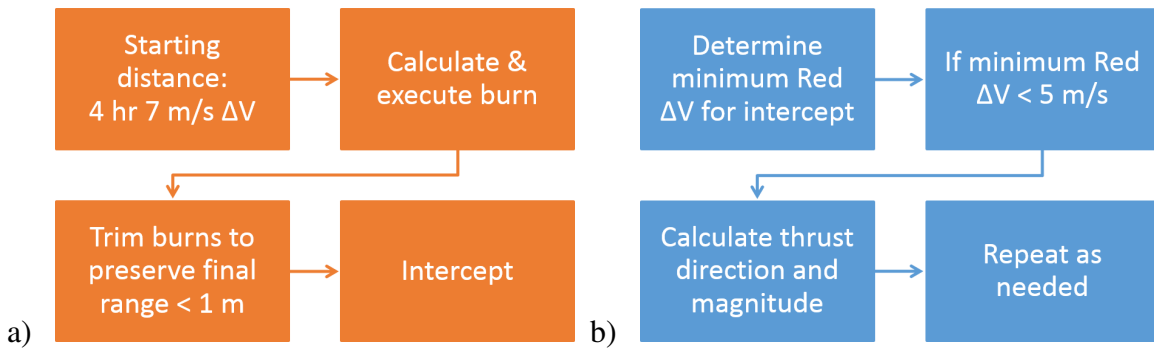

Figure 5.14. The Red aggressor tactic (a), and Blue’s minimum- ΔV evasion tactic (b).

5.2.3 Success Criteria

Blue aims to prevent Red from rendezvousing for the duration of the simulation, maximizing Red’s fuel consumption while minimizing its own. Successful evasions are scored based on the ratio of consumed fuel.

Spacecraft fuel is a critical resource in orbital engagements. Fuel is one of the principal aspects that limit the life of a spacecraft. When engineers determine a spacecraft fuel supply, it is challenging to argue for additional fuel for evasive maneuver as there is a direct correlation between weight and launch costs. Thus, most spacecraft have little to know fuel margin, and any unforecast consumption reduces the spacecraft life. Currently, there have been no demonstrated on-orbit refueling of on-orbit unmanned platforms, and while numerous companies are working on the issue, it is unlikely to see fruition at scale.

Given this environment, defenders must use any opportunity to conserve fuel and minimize excess use in the evasion maneuver. Furthermore, ΔV consumed in the maneuver is ultimately billed twice – the first time in the evasion maneuver, and the second to return to the original mission orbit when there is no longer a threat.

When analyzing results, Range was also considered as a factor. While range is not directly correlated with the difficulty of approach, given the minimum ΔV evasion technique results in closer positioning, the minimum range achieved is of interest. Non-kinetic electronic threats are ultimately range driven, their efficacy dictated by the inverse square law of signal propagation. While the comparative performance of evasion techniques cannot be associated with closing range, the value is of interest.

5.2.4 Results

This evasion technique was proven to be ineffective in some cases. When the pursuer started on the radial axis, it was successfully able to rendezvous despite Blue's evasion.

Failures

For single-axis starting locations ($\{1,0,0\},\{0,1,0\},\{0,0,1\}$), and in-track + radial ($\{1,1,0\}$), Red manages to successfully intercept Blue. An examination of the time state history for each revealed that the evasion maneuver, while effective during the continuous thrust test, is inefficient on the short time-scales. Given that orbital maneuver is partially based on the duration of the maneuver leg, when viewed from a short timespan ($<15\%$) of the orbital period the in-track maneuver is less efficient at creating in-track and radial motion.

Red takes advantage of this limitation during the last portion of its approach (for Geostationary, the last four hours). As the intercept time approaches, the CWH equation calculation increasingly identifies “direct drive” approaches that rely on thruster performance, not orbital positioning. Thus, Red transitions to a more efficient thrust for the time period, while Blue's thrust remains constant. This efficiency results in a successful intercept. This engagement is summarized in Figures 5.15 and 5.16.

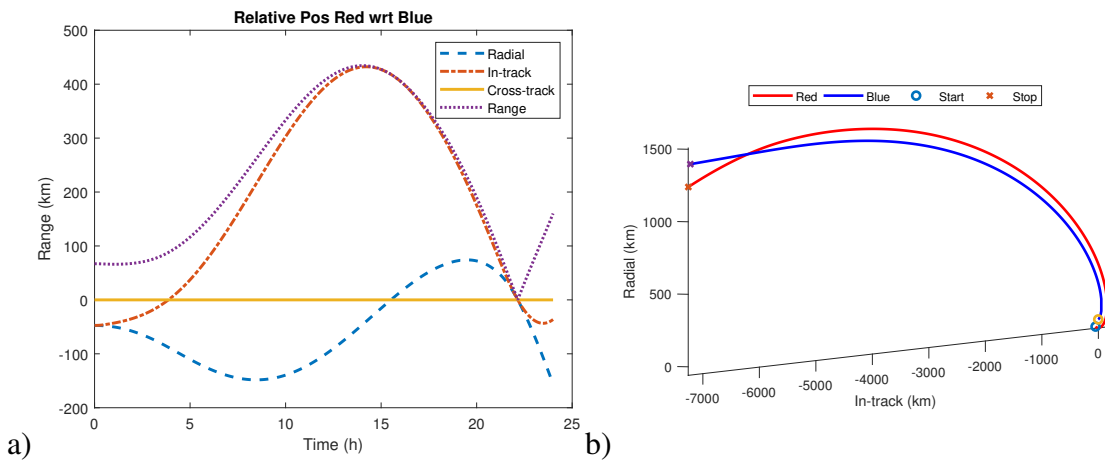

Figure 5.15. Position vs time for single direction pulse toward host (a), and relative position of the two spacecraft (b).

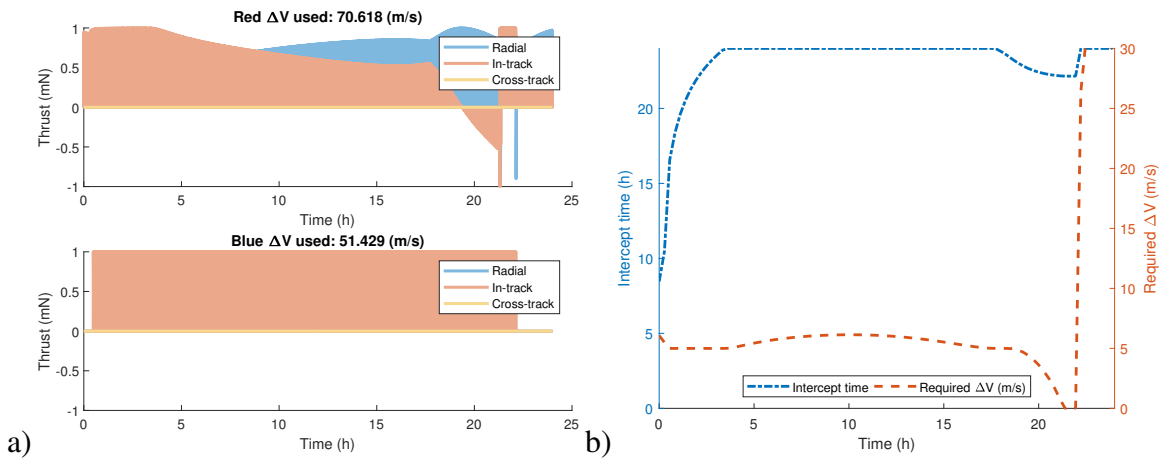

Figure 5.16. Thrust profiles for engagement scenario (a), and difficulty of achieving rendezvous and expected rendezvous time (b).

Successes

For all other starting conditions, the evasion tactic worked successfully. The “need-based” evasion thrust dramatically reduced fuel expenditure, which would allow for either longer evasions or the preservation of fuel for future missions.

At the same time, the evasions were successful in ensuring that the overall engagement was still costly for the Red aggressors, which, on average, used 50% more fuel than Blue. Even if Blue is ultimately unsuccessful in its evasion due to fuel exhaustion, by increasing Red’s

fuel usage, it shortens Red’s overall lifespan and therefore protects other targets.

5.3 Evolved Controller

To solve the problem found in the Minimum ΔV controller, a few additions were made to the control logic based on observations of the non-in-track evasions discovered in the constant direction thrust.

5.3.1 Controller Development

The results of the constant thrust test were used to improve the controller design. Three different evasion directions were shown to be most efficient in a given circumstance. Each of these cases are intended for similar situations. The three firing patterns developed were:

- *In-track* – The conventional method, where in-track thrust is applied to produce a radial change over a long period of time, thereby increasing in-track separation.
- *Radial*– Used to produce a radial separation when the intercept time is less than 15% of the orbital period.
- *Emergency*– Triggered by an extended period of time where Blue is under direct threat despite its evasion attempts and fires the thruster in all directions.

The mapping of controls is shown in Table 5.1, and the concept of operations (ConOp) is shown in Figure 5.17.

Table 5.1. Input-Output Mapping

	In-track	Radial	Emergency
{1,0,0}	○	○	●
{0,1,0}	●	●	○
{0,0,1}	○	○	●
{1,1,0}	●	●	○

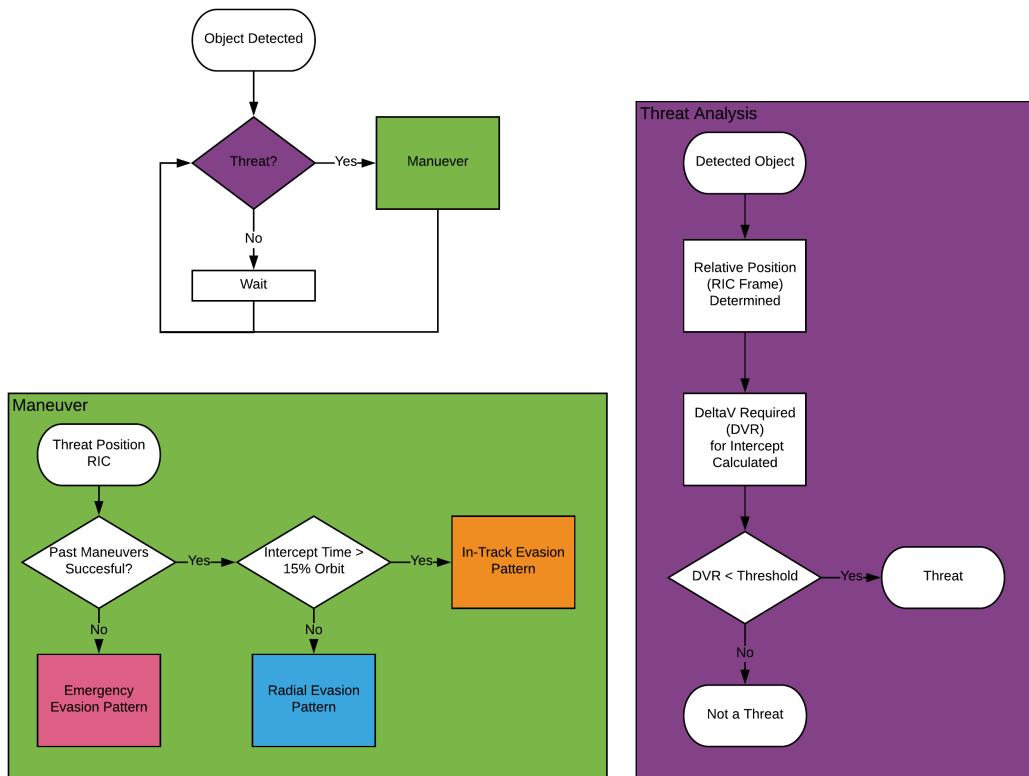

Figure 5.17. ConOp logic for evasion maneuver.

In-track Evasion Pattern The in-track evasion pattern is applied in all circumstances where the aggressor is within 7 m/s ΔV and does not intend to rendezvous within 15% of the orbit.

Radial Evasion Pattern The radial component is added when the pursuer is expected to rendezvous within 15% of the orbit. As radial thrust is more effective for short time frames, this allows Blue to successfully evade Red in short time-spans. This is highlighted in Figure 5.18 and 5.19, which can be compared to Figure 5.15 and 5.16. The principal change is between hours 18 and 22, where Blue thrusts briefly in the radial direction rather than the in-track direction. This thrust is a sufficient change to keep Red more than 16 km away from Blue, instead of the 0 m observed in the in-track only evasion.

This added pattern also reduces total fuel consumption to a ratio of 0.61 – that is Blue consumes 39% less fuel than Red while still managing to maintain appropriate separation.

Emergency Evasion Pattern The emergency evasion pattern is activated when the original pattern (either in-track or radial) fails to have a positive effect on the system after 2% of the orbital period. When this condition is met, the blue spacecraft applies thrust in all three directions. When paired with prior maneuvers, this results in a radial and cross-track separation that are out of sequence and therefore requires Red to match the maneuver to ensure appropriate synchronization.

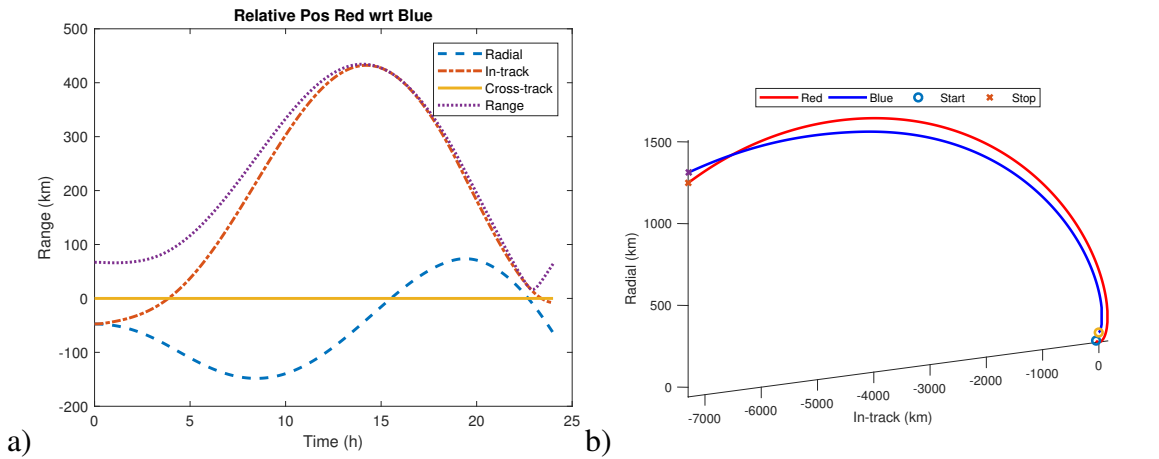

Figure 5.18. Position vs time for single direction pulse toward host (a), and relative position of the two spacecraft (b). Notice how the minimum separation has increased from 0 m in Figure 5.15 to 16 km.

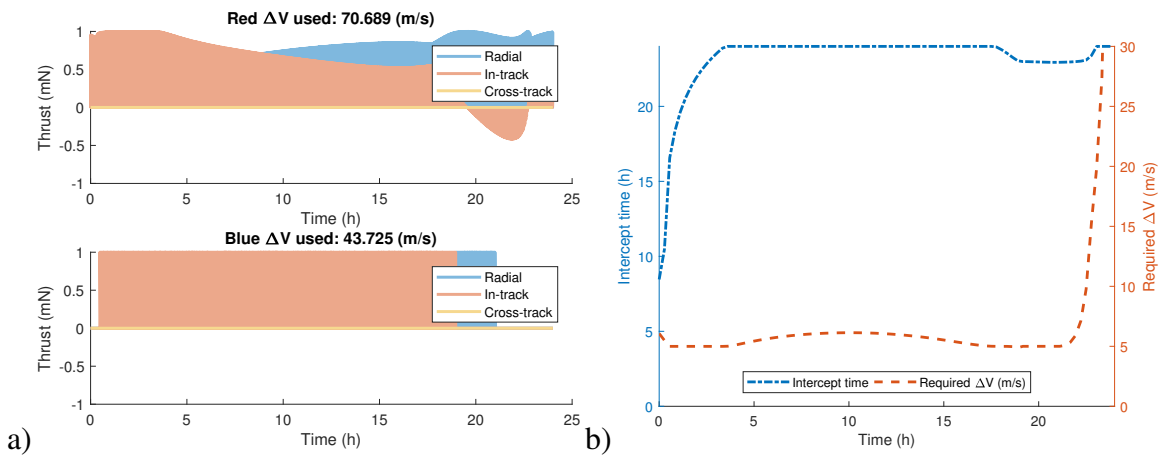

Figure 5.19. Thrust profiles for engagement scenario (a), and difficulty of achieving rendezvous and expected rendezvous time.

5.3.2 Simulation Result

The evolved controller method results in a 100% evasion rate for equally matched spacecraft. This improvement is shown in Figure 5.20. This control framework should be implemented on on-orbit assets to ensure their survivability in engagements like these.

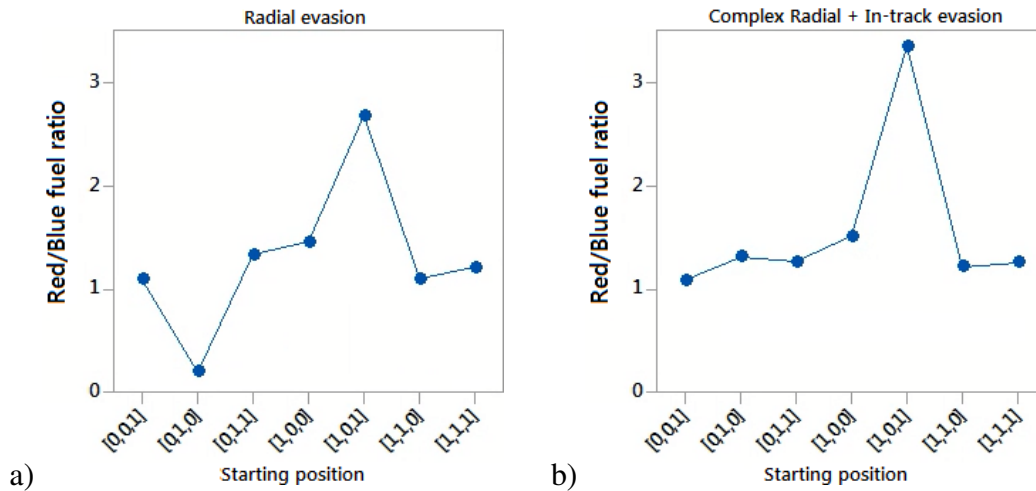

Figure 5.20. Comparison of relative fuel consumption for engagements from a variety of directions using the in-track only controller (a), and the evolved in-track + radial controller (b).

Summary

The ultimate goal for the defender in each engagement is to conserve fuel while preventing rendezvous. Simulations applying thrust in a variety of directions in response to an aggressor starting in various positions determined that the direction of thrust alters the efficiency of the evasion and that in most circumstance in-track evasion is most efficient. By triggering in-track thrust based on the pursuer's ΔV required to rendezvous, a control system was developed to minimize the defender's fuel consumption. Further analysis determined the best evasion direction in cases where the in-track thrust was ineffective, namely when the aggressor intends to rendezvous within 15% of the orbital period. These effects are incorporated into the proposed tactics to prevent rendezvous. This evasion tactic results in the defender using 30-50% less fuel than the aggressor while still evading.

THIS PAGE INTENTIONALLY LEFT BLANK

CHAPTER 6: Spacecraft Design Factors

This chapter discusses spacecraft design factors that are applicable in evasion circumstances and evaluates the effect of varying these factors. It begins with an examination of possible effects, then proceeds to detail the modeling method for each. The results of these models are presented and used to craft recommendations for future spacecraft procurement.

6.1 Spacecraft Parameters

To assess what components might affect satellite engagements, an assessment of the spacecraft's systems is necessary. This assessment is best conducted from the perspective of maneuver planning – the primary influences on that are

- *State Knowledge*– Ability to know the enemy's relative position and orbit.
- *Maneuvering*– Magnitude and limitation on possible evasive maneuvers.
- *Intelligence*– Knowledge of enemy tactics can greatly affect the outcome of an engagement.

Mapping each of these influences to spacecraft systems allows for an analysis of what components effect evasion. Typical spacecraft have five main systems: attitude determination and control system (ADCS), command and data handling system (C+DH), electrical power system (EPS), Maneuvering System, and the communication system (Comms) [31]

- *ADCS*– Used to assess and change the orientation of the spacecraft, only relevant if there are particularly sensitive areas of the spacecraft or if the thrust direction is dependent on the orientation of the spacecraft.
- *C+DH*– The C+DH system controls information flow on the spacecraft and would ultimately be responsible for executing any evasion maneuvers. Its update frequency and available computing power dictate the possible complexity of evasive maneuvers.
- *EPS*– The EPS is required to keep the mission payload and spacecraft bus running. The versatility of the power generation component and its ability to adapt to different spacecraft orientations is necessary if the ability to apply thrust is dependent on

spacecraft orientation.

- *Maneuvering System*– The maneuvering system is critical in any evasion maneuver, and is likely a primary driver in evasion capability.
- *Comms*– The Comms system may be needed to provide real-time data on the adversary’s position based on ground or other asset tracking. The spacecraft orientation requirements, plus the resiliency and security of the communications system dictate whether such engagements are possible.

From a physical perspective, these systems limit the spacecraft’s ability to

- *State Knowledge*– The capabilities of the command and data handling system can govern on-orbit processing capability for evasions in communications denied environments, while the resilience of the communications system can prevent these denied environments from existing.
- *Maneuver*– Direct limitations come from the design of the maneuvering system in the form of overall acceleration, available ΔV and maneuvering frequency. Additionally, the design of the EPS and Comms can limit the orientation of the spacecraft and therefore limit maneuvering.
- *Intelligence*– The C+DH system and communications system can provide data on the engagement to ground controllers to allow for improved evasion techniques in future encounters.

By varying the performance of these relevant systems and determining the effect on an engagement scenario, it is possible to evaluate their impact on the engagement.

6.2 Design of Experiment

A design of experiment was constructed to evaluate the effect of changing system parameters.

6.2.1 Maneuvering System

The maneuvering system’s ability to conduct rendezvous maneuvers is dependent on two factors: it’s ability to accelerate the spacecraft and the rate at which it can adjust its course

- *Acceleration*– The spacecraft’s acceleration is modeled by its thrust output. In some

cases, the limits on a spacecraft's acceleration may be based on its structure and the durability of any deployed structures. For the DOE, the spacecraft's acceleration was tested as a relative factor to the aggressor's acceleration. Testing was conducted to ensure scalability between very low baseline thrust (0.001 m/s^2) and higher thrust (10 m/s^2); the results were comparable across the regime.

- *Firing Rate*– The firing rate represents the spacecraft's ability to change direction. It takes into account any cool-off period that the thruster system may require between firings. Ultimately, this limits the overall ΔV the system is capable of outputting across the simulation.

6.2.2 Sensors

The sensor systems used to track both objects are not necessarily located on each spacecraft and may use cross-linked data from other assets. Regardless, three main criteria may affect the evasion circumstance

- *Update Frequency*– The update frequency takes into account the time needed to determine the new orbital parameters in response to maneuver. For the purpose of simulation, this parameter is part of the firing rate criteria described in the maneuvering system section.
- *Range*– This paper advocates for a disaggregated array of sensors that are not limited to the Blue spacecraft. As such, the range at which detections can take place is only of tertiary importance.
- *Accuracy*– The accuracy of the sensor package dictates how effective an evasion can be, based on how large a margin of error exists in the evasion maneuver. Ultimately, well-characterized sensor accuracy is needed when developing the evasion technique.

6.2.3 Predictive Evasion

The model constructed in this report uses optimal approach trajectories and does not require knowledge of the aggressor's tactic. However, the more information that is known, particularly knowledge of when the pursuer will abandon the pursuit, the more efficient the evasion.

6.2.4 Experiments Setup

Ultimately, given the large amounts of research into space situational awareness networks and systems, an evaluation of sensor performance was deemed unnecessary. The concepts and plans for SSA promise to provide sufficient capability to track and characterize satellite maneuvers on orbit.

The focus of the research is the maneuvering system, and any delays present in it or in receiving actionable state knowledge. To provide the most general – and therefore widely applicable – results, the relative performance of the aggressor and pursuer were compared in a variety of simulation conditions. For each simulation, the starting position and simulation time were varied to determine if specific advantages were present in specific situations.

The following configurations were studied:

- *Simulation Duration*– The simulation duration was set to either 4, 12 or 24 hours (16%, 50%, or 100% period).
- *Starting Position*– Given the symmetry of starting positions observed in the previous testing, the starting positions included any in the 1st quadrant.
- *Maneuver Delay*– The maneuver delay was relative to the other spacecraft; there was either zero maneuver delay for both spacecraft, or Red had a 10-minute delay while Blue had a multiple of that; either 50%, 100%, or 200% of Red’s delay.
- *Acceleration*– Four different accelerations were tested. Red’s thrust was fixed for certain circumstances; $0.001\ m/s^2$ was used for continuous thrust applications, $0.01\ m/s^2$ was used for pulsed thrust. Blue’s thrust was set to a multiple of Red’s thrust, either 50%, 100%, or 200%.
- *Evasion Velocity*– The evasion velocity is the magnitude of Blue’s response to Red’s maneuver. This velocity is purely a tactics parameter; it is not necessarily dependent on the host systems. However, it is important to evaluate a variety of evasive maneuver magnitudes to determine if larger evasive maneuvers can compensate for longer maneuver delay or slower acceleration.

6.2.5 Batch-run Results

Figure 6.1 shows an effects plot for the design of experiment. The criteria for successful evasion was set at a distance of 10 km based on an optical or directed energy threat. The

scoring system was binary – a one represented a successful evasion, while a zero represented a failure.

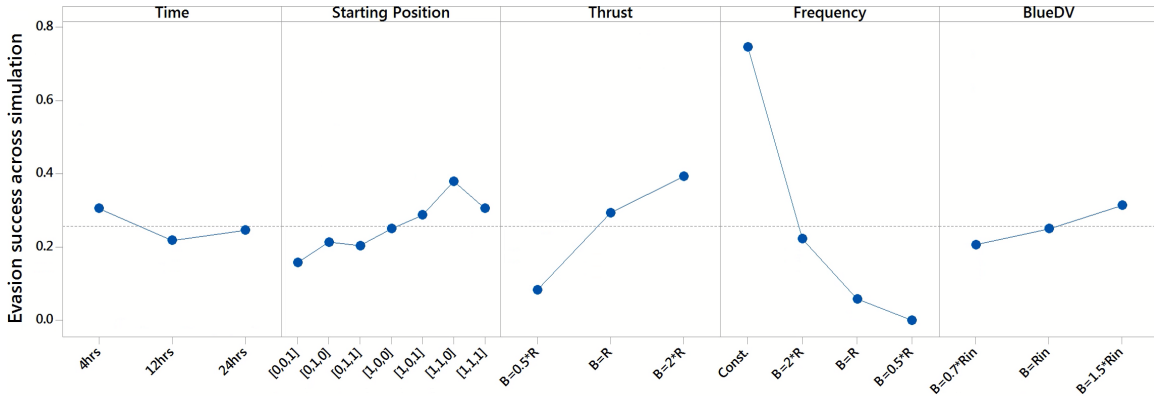

Figure 6.1. Main effects plot for engagement evasion with binary success criteria based on closest point of approach of 10 km.

A second plot, Figure 6.2 shows scores from the same DOE that are assigned based on the ratio of Red’s fuel consumption to Blue’s fuel consumption. Higher values are scenarios when Red uses substantially more fuel than Blue and therefore represent more effective evasions.

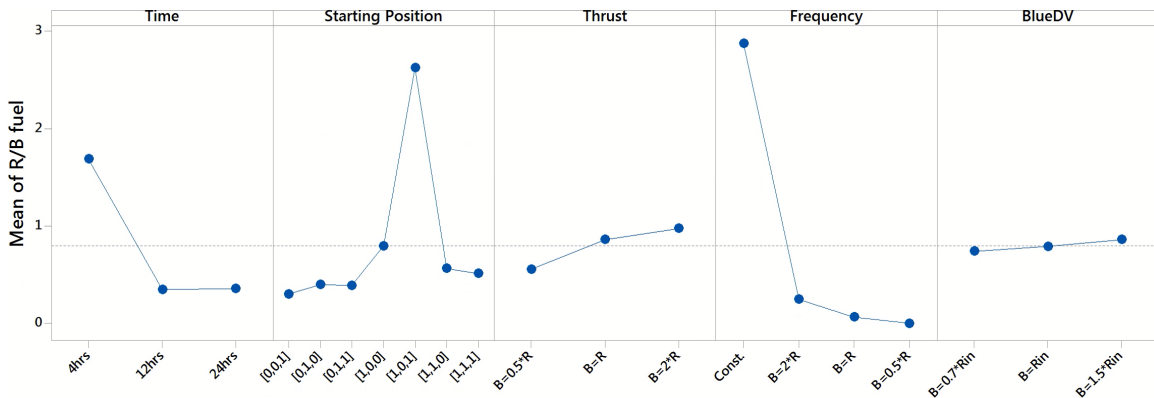

Figure 6.2. Main effects plot for engagement evasion with fuel based success criteria based on closest point of approach of 10 km.

Time

The first category, simulation time, shows how the longer the pursuit, the easier it is for the aggressor to rendezvous. Shorter time windows force engagements to use inefficient thrust patterns to complete the rendezvous, which provides an advantage to the defender. Furthermore, shorter engagement windows (particularly the four-hour engagement) prevent natural orbital mechanics from immediately aiding the rendezvous.

Starting Position

Figure 6.1 shows approximately equal starting position success rates, which reflects how the starting positions are calibrated to be situated such that the difficulty of rendezvous is comparable between scenarios. It does show how, despite this calibration factor, pure cross-track approaches ([0,0,1]) are difficult to defend against.

The fuel burn relationship in Figure 6.2 shows how some approaches are naturally ineffective for Red, particularly [1,0,1]. This approach is ineffective because radial and cross track displacements do not result in a natural intercept. Thus, Blue does not need to change its orbit significantly to evade the engagement.

Thrust & Frequency

Figure 6.4 shows how a thrust over-match, where Blue has more thrust than Red, provides limited performance enhancement, while the thrusting frequency provides the largest impact on performance. It also shows how varying the Blue evasion ΔV magnitude can compensate for changes in frequency or thrust; however, it is not able to completely compensate using the values tested.

High-frequency maneuvers, approaching continually updating trajectory, provides the best evasion. This is because the enemy is never able to take advantage of rest periods to close the distance between spacecraft. This configuration is able to maneuver whenever necessary and does not result in over or under correction. Constant updates result in a more efficient evasion process. Figure 6.3 shows a comparison in intercept ΔV requirements with Blue having a constant and pulsed firing rate. The constant firing rate results in Red targeting the endpoint of the simulation nearly four hours earlier, which minimized Blue's fuel consumption.

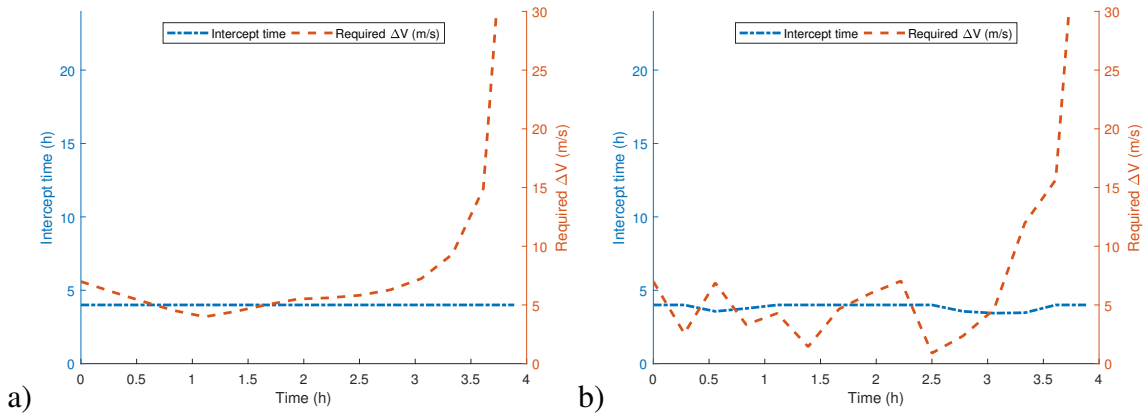

Figure 6.3. Comparison of ΔV intercept requirements with constant maneuver (a) and pulsed maneuver (b).

Figure 6.2 shows how modifying the thrust output provides a minimal change in ΔV expenditure. This is because the adversary always has the option of firing its thruster longer to match the Blue maneuver. As such, while that process does limit Red's maneuverability, it does not provide a substantial maneuvering advantage as both spacecraft still consume the same amount of ΔV .

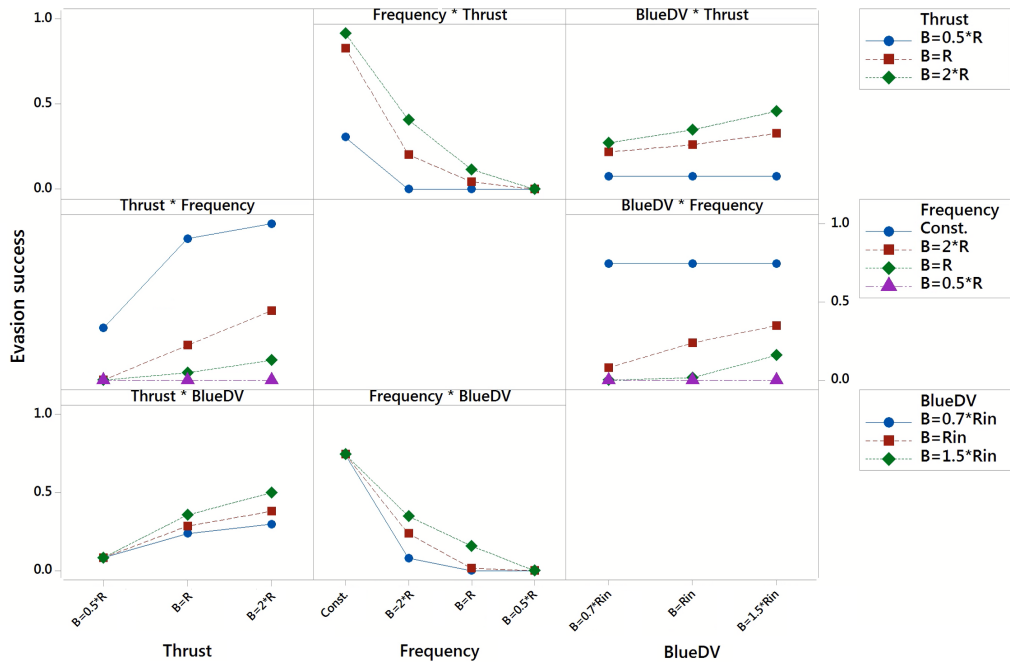

Figure 6.4. Interaction plot for engagement evasion with range-based success criteria based on closest point of approach of 10 km.

6.3 Recommendations

Given the threat conditions described in Chapter 2, it is clear that any spacecraft is vulnerable to attack. Designers and operators should consider their role in successfully defending their spacecraft

- *Designers*– When building spacecraft, an emphasis should be placed on reducing any delays between thruster firing, whether those delays are to assess the enemy’s position or mechanical constraints in the thruster system. Spacecraft with continuous thrust propulsion systems (like spacecraft equipped with electric propulsion) have an advantage in evasion scenarios as they can more closely tailor their evasion maneuver to the circumstance (provided the acceleration of the thruster over the engagement period matches or exceeds that of the adversary.
- *Operators*– Existing spacecraft operators should be prepared to maneuver their spacecraft to avoid such threats and must analyze appropriate evasive maneuvers in advance.
- *Analysts*– Determining at what point a spacecraft is under attack vs. merely being approached out of coincidence is key in forming a prompt response. Understanding when a spacecraft is under threat, and noting that range itself is nearly immaterial in space, is necessary to establish the policy precedents to recognize and deter aggression.

Summary

A parametric analysis of spacecraft design parameters was conducted using the proposed evasion technique to determine what physical components matter in space combat. When using this evasion technique, the spacecraft’s ability to rapidly and repeatedly fire its thruster with a minimum delay between thruster firing is the driving performance factor, while thruster power and maneuver intensity are less critical. Spacecraft with continuous thrust engines, like those equipped with electronic propulsion, are at an advantage in engagement scenarios.

CHAPTER 7: Conclusion

This thesis presents recommendations as to the terminology, tactics and design features necessary to harden and defend orbital infrastructure against co-orbital threats. The thesis follows a progression from the threat to the evasion technique, which results in a method that provides defending spacecraft evasion method with a 50% fuel advantage. The main lessons learned from this process are

- *Threat Environment (Chapter 2)*– While there are a variety of threats to spacecraft, the co-orbital threat has several advantages. If conducted correctly, a co-orbital attack does not generate harmful orbital debris, is difficult to attribute, and is scalable to provide varying levels of damage. Co-orbital vehicle can be used for show of force style operations to deter aggression and to hold other spacecraft at risk. Finally, a co-orbital vehicle can be developed as a satellite servicing vehicle and may even be able to engage in the servicing industry.
- *Engagement Simulation (Chapter 3)*– Using the CW equations, a Simulink model was made to simulate co-orbital interactions and allow two spacecraft to “dogfight.” This model was demonstrated to provide similar performance to high-precision propagators over short time-spans. The model allows for tactics development and verification across a variety of orbital conditions. This model also functions as a test platform for operator training and development, by allowing operators to test evasion concepts against generic adversaries.
- *Positions of Advantage (Chapter 4)*– Space maneuver is very different than terrestrial maneuver. Given the orbital dynamics, unlike terrestrial combat, there is little relation between distance and difficulty of access. Threats must be categorized based on the difficulty of rendezvous instead of range, which provides a more accurate estimate of threat likelihood and affords the defending spacecraft the opportunity to react appropriately.
- *Evasion Tactics (Chapter 5)*– Evasive maneuver is largely dependent on the expected time of intercept. Tactics development was undertaken using two identical modeled spacecraft. Simulations applying thrust in a variety of directions in response to an

aggressor starting in various positions produced an understanding of the best general evasive maneuver. These effects are incorporated into the development of tactics to prevent rendezvous. The ultimate goal of each engagement is survival. A large part of survival for spacecraft is fuel conservation; the defensive objective is to maintain separation from the pursuer while minimizing the defender's fuel consumption and maximizing the aggressor's consumption. The proposed four-step tactic accounts for these relationships and results in the defender using 30-50% less fuel than the aggressor while still evading.

1. If the pursuer starts radially above the defender, the defender applies thrust in negative directions as determined by the following steps. Thrust in the positive direction is applied if the pursuer starts below.
 2. While the pursuer is not on a trajectory to rendezvous within 15% of the orbital period, in-track thrust is applied to produce a radial change over a long period, thereby increasing in-track separation.
 3. When the pursuer is tracking to intercept in less than 15% of the orbital period, the defender switches to radial thrust.
 4. If the chosen evasion technique does not increase the rendezvous difficulty over the course of 30 minutes, an all-direction evasion technique is applied.
- *Parametric Analysis (Chapter 6)*– Using these tactics, parametric analysis of spacecraft design parameters can be conducted to determine what physical components matter in space combat. When using this evasion technique, the spacecraft's ability to rapidly and repeatedly fire its thruster with a minimum delay between thruster firing is the driving performance factor, while thruster power and maneuver intensity are less critical. Spacecraft with continuous thrust engines, like those equipped with electronic propulsion, are at an advantage in engagement scenarios.

This analysis is intended as a starting point for tactics development. There are numerous components of this model that warrant further study. Some recommendations:

- *Angles Only*– Given that not all spacecraft may have access to real-time sensor data (as a result of jamming or orbital location), it may be necessary to evade based on data generated using onboard systems, which are unlikely to produce full state information. The use of antenna maneuvers to locate jamming sources, onboard cameras to locate nearby space objects, and other unorthodox sensor employment should be reviewed

to determine if sufficient information exists to execute some form of planned evasive maneuver.

- *Communications Denied Environment*– Many attackers may use jamming to prevent commanding evasive maneuver. For existing spacecraft that are not equipped to detect and react to co-orbital threats with onboard systems may be able to react based on loss of communications and execute a preloaded evasive maneuver based on the location of the vehicle that is most likely the threat. This information could be uploaded to the spacecraft periodically, for execution in case of emergency.
- *Flee to Location*– It may be advantageous to flee to a location where a friendly actor (spacecraft or ground-launched weapon) can defend the target. Some calculation of the maneuvers necessary to evade the pursuer while still moving toward a targeted area would be necessary.

THIS PAGE INTENTIONALLY LEFT BLANK

List of References

- [1] “The space report 2017: The authoritative guide to global space activity,” Space Foundation, Colorado Springs, CO, USA, 2017. [Online]. Available: <https://www.thespacereport.org/>
- [2] T. Delphech, *Nuclear Deterrence in the 21st Century*. Santa Monica, CA, USA: RAND Corp., 2012. [Online]. Available: https://www.rand.org/content/dam/rand/pubs/monographs/2012/RAND_MG1103.pdf
- [3] *North Sea Continental Shelf Cases (Federal Republic of Germany v. Denmark; Federal Republic of Germany v. Netherlands)*. I.C.J. Reports 1969, International Court of Justice (ICJ), Feb. 20. 1969. [Online]. Available: <http://www.icj-cij.org/files/case-related/51/051-19690220-JUD-01-00-EN.pdf>
- [4] D. Trump, “National security strategy of 2017,” Washington, DC, USA 2017.
- [5] D. Trump, “National space strategy of 2018 (fact sheet),” Washington, DC, USA 2018.
- [6] G. Neuneck, “China’s ASAT test — A warning shot or the beginning of an arms race in space?” in *Yearbook on Space Policy*, K. Schrogl, C. Mathieu and N. Peter, Eds. Wien, Austria: Springer-Verlag/Wien, 2007, pp. 211–224.
- [7] S. Davis, “2008 satellite shot down,” Missile Defense Agency, March 12, 2014. [Online]. Available: https://mda.mil/video/timeline_2008_down.docx
- [8] R. Gordon, “The landmark space age Thucydides: Human spaceflight in the state grand strategic quest to address fears, advance interests, and garner honor,” M.S. thesis, Air University, School of Advanced Air and Space Studies, Maxwell Air Force Base, AL, USA, 2011. [Online]. Available: <http://www.dtic.mil/docs/citations/AD1019698>
- [9] E.A. Hanlon, B.P. Keegan, M.E. Lange, J.K. Pittman, D.L. Wenberg, J.G. Roser and J.S. Kang, “Leveraging the autonomous mobile on-orbit diagnostic system to initiate a doctrinal shift in spacecraft operations,” in *Space Operations: Contributions from the Global Community*, C. Curzen, M. Schmidhuber, Y. Lee, and B. Kim, Eds. Cham, Switzerland: Springer International Publishing, 2017, pp. 53–86.
- [10] H.O. Boelcke and M. Shackelford, “Dicta Boelcke: Rules of success in air combat,” Brigham Young University, April 11, 1996. [Online]. Available: <http://net.lib.byu.edu/~rdh7/wwi/comment/dicta-b.html>

- [11] E.A. Hanlon, "Survivability analysis of a small satellite constellation," in *34th Space Symposium*, Colorado Springs, CO, USA 2018. [Online]. Available: https://spacefoundation.org/sites/default/files/tech-track-papers/Hanlon-Edward_Survivability%20Analysis%20of%20a%20Small%20Satellite%20Constellation_1.pdf
- [12] T. Wilson, "Threats to United States space capabilities," Space Commission, January 11, 2001. [Online]. Available: <https://fas.org/spp/eprint/article05.html>
- [13] S. Northcutt, "Are satellites vulnerable to hackers," Sans Technology Institute, May 15, 2007. [Online]. Available: <https://www.sans.edu/cyber-research/security-laboratory/article/satellite-dos>
- [14] D.J. Kessler, N.L. Johnson, J.C. Liou, and M. Matney, "The Kessler Syndrome: Implications to future space operations," in *33rd Annual AAS Guidance and Control Conference*, Breckenridge, CO, USA, 2010. [Online]. Available: <http://citeseerx.ist.psu.edu/viewdoc/download?doi=10.1.1.394.6767&rep=rep1&type=pdf>
- [15] M. Krepon, "Anti-satellite weapons, deterrence and Sino-American space relations," Naval Postgraduate School (NPS), Center on Contemporary Conflict (CCC), Monterey, CA, USA, 2013. [Online]. Available: <http://www.dtic.mil/dtic/tr/fulltext/u2/a587431.pdf>
- [16] K. Segal, "NASA: Space junk passes less than 4 miles from space station," CNN, April 5, 2011. [Online]. Available: <http://www.cnn.com/2011/US/04/05/space.station.debris/index.html>
- [17] L. Grego, "A history of anti-satellite programs," *Union of Concerned Scientists*, Cambridge, MA, USA, January 2012. [Online]. Available: http://www.ucsusa.org/sites/default/files/legacy/assets/documents/nwgs/a-history-of-ASAT-programs_lo-res.pdf
- [18] L. Wood, "Russia tests anti-satellite weapon," *The Washington Times*, Dec. 21, 2016. [Online]. Available: <http://www.washingtontimes.com/news/2016/dec/21/russia-tests-anti-satellite-weapon-pl-19-nudol/>
- [19] B. Gertz, "China prepares for anti-satellite missile test," *The Washington Free Beacon*, Dec. 9, 2016. [Online]. Available: <http://freebeacon.com/national-security/china-prepares-satellite-missile-test/>
- [20] S. Lambakis, *On the Edge of Earth: The Future of American Space Power*. Kentucky, USA: University Press of Kentucky, 2013. [Online]. Available: https://books.google.com/books?id=3WxHAgAAQBAJ&dq=miracl+msti3&source=gbs_navlinks_s

- [21] “Russian engineers finish work on laser capable of shooting down enemy satellites,” Sputnik News, February 22, 2018. [Online]. Available: <https://sputniknews.com/military/201802251061979166-russia-creates-airborne-antisatellite-laser/>
- [22] Z. Yu-quang, W. Zhi-hong, and G. Ming-hui, “Development of space-based laser weapon systems,” *Chinese Optics*, December 2013. [Online]. Available: <http://www.chineseoptics.net.cn/CN/article/downloadArticleFile.do?attachType=PDF&id=9082>
- [23] J. Parrish, “Robotic Servicing of Geosynchronous Satellites (RSGS),” Defense Advanced Research Projects Agency (DARPA). [Online]. Available: <https://www.darpa.mil/program/robotic-servicing-of-geosynchronous-satellites>
- [24] M. Gruss, “Maneuvering Russian satellite has everyone’s attention,” *SpaceNews*, July 2015. [Online]. Available: <http://spacenews.com/maneuvering-russian-satellite-has-everyones-attention/>
- [25] “China’s new orbital clean-up satellite raises space militarization concerns,” SpaceFlight101, June 2016. [Online]. Available: <http://spaceflight101.com/long-march-7- maiden-launch/aolong-1-asat-concerns/>
- [26] K. Gowd, “Defending space assets,” *Geospatial World*, December 2013. [Online]. Available: <https://www.geospatialworld.net/article/defending-space-assets/>
- [27] E. Lee, “Developing sensors to defend aircraft against lasers,” *Phys.org*, September 29, 2017. [Online]. Available: <https://phys.org/news/2017-09-sensors-defend-aircraft-lasers.html>
- [28] “AGI Help Files,” Analytical Graphics Inc (AGI) System Tool Kit (STK). [Online]. Available: <http://help.agi.com/stk/index.htm#stk/referenceframesvgt.htm>
- [29] “The Clohessy Wiltshire Model,” University of Texas. [Online]. Available: http://www.ae.utexas.edu/courses/ase366k/cw_equations.pdf
- [30] “Orbital propagators for satellites,” Analytical Graphics Inc (AGI) System Tool Kit (STK). [Online]. Available: http://help.agi.com/stk/11.0/Content/stk/vehSat_orbitProp_choose.htm
- [31] J. Sellers, *Understanding Space: An Introduction to Astronautics*, 3rd Ed. New York, USA: McGraw-Hill, 2005.

THIS PAGE INTENTIONALLY LEFT BLANK

Initial Distribution List

1. Defense Technical Information Center
Ft. Belvoir, Virginia
2. Dudley Knox Library
Naval Postgraduate School
Monterey, California