

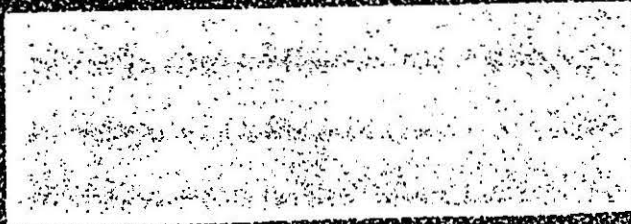


CIA HISTORICAL REVIEW PROGRAM  
Release As Sanitized  
1996

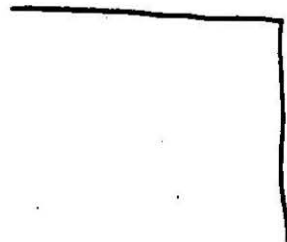
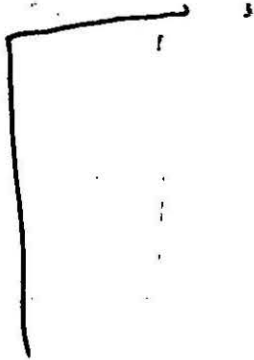
# Warsaw Pact Nonnuclear Threat to NATO Airbases in Central Europe

National Intelligence Estimate

Approved for Release by NSA on 05-08-2014 pursuant to E.O. 13526  
Room 7E-47 HQS



~~TOP SECRET~~



NIE 11/20-6-84

WARSAW PACT  
NONNUCLEAR THREAT  
TO NATO AIRBASES  
IN CENTRAL EUROPE

Information available as of 2 October  
1984 was used in the preparation of this  
Estimate, which was approved by the  
National Foreign Intelligence Board on  
that date.

THIS ESTIMATE IS ISSUED BY THE DIRECTOR OF CENTRAL INTELLIGENCE.

THE NATIONAL FOREIGN INTELLIGENCE BOARD CONCURS, EXCEPT AS NOTED IN THE TEXT.

*The following intelligence organizations participated in the preparation of the Estimate:*

The Central Intelligence Agency, the Defense Intelligence Agency, the National Security Agency, and the intelligence organization of the Department of State.

*Also Participating:*

The Assistant Chief of Staff for Intelligence, Department of the Army

The Director of Naval Intelligence, Department of the Navy

The Assistant Chief of Staff, Intelligence, Department of the Air Force

The Director of Intelligence, Headquarters, Marine Corps

## CONTENTS

	<i>Page</i>
SUMMARY AND KEY JUDGMENTS.....	1
DISCUSSION.....	9
I. INTRODUCTION.....	9
A. General.....	9
B. Warsaw Pact Concepts for a War Against NATO in Europe.....	9
II. WARSAW PACT AIR FORCE STRUCTURE AND THREAT TO NATO CENTRAL REGION AIRFIELDS	12
A. Tasks.....	12
B. Forces.....	15
C. Command, Control, and Communications.....	15
D. Conventional Munitions.....	16
E. Logistics and Support.....	17
F. The Air Operation.....	19
G. Future Developments.....	21
III. SHORT-RANGE BALLISTIC MISSILES.....	22
A. General.....	22
B. Force Development.....	22
C. SRBM Force Structure in the Western TVD.....	27
D. SRBM Missile Storage and Transport.....	28
E. Impact of Future Systems.....	30
F. SRBM Threat Assessment.....	31
IV. SOVIET SPECIAL PURPOSE FORCES—SPETSNAZ....	32
A. Introduction.....	32
B. Missions.....	34
C. Organization.....	35
D. Employment of Special Purpose Forces in the NATO Central Region.....	35

	<i>Page</i>
V. AIRBORNE AND AIR ASSAULT OPERATIONS .....	37
A. General.....	37
B. Employment.....	38
C. Airfield Attack.....	38
VI. OPERATIONAL MANEUVER GROUPS (OMGs).....	40
A. General.....	40
B. Missions.....	40
C. Employment.....	40
D. Capabilities: Theory Versus Practice .....	40
E. Force Developments.....	40
VII. CRUISE MISSILES, RECONNAISSANCE STRIKE COMPLEX, AND SURFACE-TO-AIR MISSILE THREATS.....	41
A. Current Developments .....	41
B. Future Developments .....	41
C. Reconnaissance Strike Complex System.....	41
D. Surface-to-Air Missiles.....	42
VIII. AN ILLUSTRATIVE SCENARIO OF A WARSAW PACT NONNUCLEAR AIR OPERATION AGAINST NATO CENTRAL REGION AIRFIELDS .....	43
A. General.....	43
B. The Air Operation.....	43
C. Summary: Future Soviet Airfield Attack Capability....	46
ANNEX: Selected Bibliography .....	51

## SUMMARY AND KEY JUDGMENTS

Soviet planners regard NATO's tactical air forces in the Central Region as a formidable threat to their ground, air, and naval forces in a conventional conflict. The Soviets recognize that NATO's air assets provide the bulk of the NATO theater nuclear capability and that the success of NATO ground force operations is dependent upon tactical air support. The Soviets consider the early attainment of air superiority and the destruction or neutralization of NATO's theater nuclear forces to be critical to the Pact's chances for victory in Europe.

The Soviets plan to conduct a Theater Strategic Operation (TSO) against NATO in Central Europe, an area the Soviets describe as the Western Theater of Military Operations (WTVD). It would be characterized by multiple, successive front operations supported by the Strategic Air Forces, the Strategic Rocket Forces, and the Baltic Fleet, and controlled by a single high command of forces in the TVD. We believe the Soviets plan to complete this operation in a period of 20 to 30 days.

We would also expect that, concurrently with initiating a TSO against NATO in Central Europe, the Soviets would attack NATO's northern and southern regions to keep NATO from shifting forces from the flanks to Central Europe and to compel commitment of NATO reserves. We would expect some limited simultaneous air operations against key NATO airfield complexes in Norway designed to establish air superiority over the Norwegian Sea and adjacent waters in order to reduce the vulnerability of air and naval operations in the area.

Pact military planners assign their air forces three general tasks for conventional war in a continental TVD—to gain and maintain air superiority, to destroy the nuclear delivery capability of the enemy, and to support the ground forces. Other theater support roles for the air forces would include close air support, neutralization of enemy reserves, aerial reconnaissance, electronic warfare, airdrop/airlanding operations, and airlift of supplies.

To accomplish their goals, the Soviets have a nonnuclear operational concept, the air operation,<sup>1</sup> designed to neutralize NATO air, air

<sup>1</sup> For the purposes of this Estimate the term "the air operation" refers to the initial air operation involving multiple massed air raids conducted over a period of several days during the initial phase of hostilities.

defense, and theater nuclear resources during the first several days of hostilities. Supporting forces could include short-range ballistic missiles (SRBMs), special purpose forces (Spetsnaz), airborne, and other assets.

The Soviet General Staff, acting as executive agent for the Supreme High Command (VGK), would perform the initial planning and allocation of VGK assets, ensure strategic reconnaissance is accomplished, and reallocate air forces among TVDs, if necessary. The High Command of the Western TVD would perform the detailed planning and direct the theater air operation.

Pact planners regard destruction of NATO aircraft as the primary way of gaining air superiority and expect airfield attacks to account for many of the aircraft NATO would lose during the air operation. Key to the neutralization of NATO air assets would be the destruction or degradation of NATO airbases. In an attempt to destroy or neutralize NATO's nuclear capability, the Pact would concentrate attacks on those bases from which they expect nuclear delivery aircraft to operate and would also assign high priority to bases housing air defense fighters. The prevention of the early use of these assets might well be enough for the Soviets to regard a preemptive air operation as having fulfilled its objectives.

We believe these to be the principal characteristics of an air operation conducted against NATO's Central Region:

- The Pact would most likely commit elements of two to four strategic air armies, three to five front air forces including non-Soviet Warsaw Pact (NSWP) air forces, and various air defense, transport, and Baltic Fleet naval aviation units in a series of major air raids designed to achieve as much tactical surprise as possible.
- Each major raid would begin with a concerted effort to establish corridors through NATO air defenses, which Pact aircraft would then use to attack airfields, surface-to-surface missile launchers, nuclear weapons storage facilities, command, control, and communications facilities, and other priority targets.
- SU-24 Fencers and Soviet medium bombers would constitute the primary force for attacking airfields and possibly nuclear storage facilities.
- Fighter-bombers from the air forces of the fronts would be used to suppress air defenses and to attack fixed installations (to include airfields) and missile launchers. Other tactical and



strategic aircraft would provide fighter cover, escort, reconnaissance, and radioelectronic combat missions. NSWP air defense fighters would provide strategic air defense of their homelands.

- Aircraft operations would be supported primarily by employment of SRBMs, artillery, and Spetsnaz to attack critical surface-to-air missile (SAM) sites, command, control, and communications sites, and airfields within range.
- Some Soviet and NSWP bomber, fighter-bomber, and fighter aircraft would be withheld for nuclear operations

We believe that the Pact could have available 2,600 to 4,100 fixed-wing aircraft for operations against the NATO Central Region and that it probably has contingency plans for initiating the air operation from a variety of different postures. For offensive air operations in Central Europe, the Warsaw Pact could draw from:

- Strategic Aviation.
- Soviet Air Forces of the Groups of Forces in East Germany and Czechoslovakia and the three Western military districts.
- National Air Forces of East Germany, Czechoslovakia, and Poland.
- Baltic Fleet air forces.

The heart of the air operation would be a series of daylight airfield attacks designed to destroy a portion of NATO's air forces sufficient to establish strategic air supremacy and to reduce substantially NATO's nuclear strike potential. Airbases housing fighter-bomber wings with nuclear strike roles generally are the top-priority targets in Soviet exercises because their destruction would simultaneously satisfy both objectives. Fighter bases also would be attacked. Soviet military writings note that front aviation also would make small-scale attacks against NATO airfields between the massed air raids in support of front objectives.

We believe that, if aircraft attrition rates were substantially higher than expected, the Soviets could be forced to cancel the air operation after only one or two massed air raids—before it accomplished its objective of attaining air supremacy. Factors affecting attrition rates would include:

- Higher-than-expected survivability of NATO's ground-based air defenses.

- NATO airborne warning and control system aircraft and look-down/shutdown fighters limiting opportunities for Pact aircraft to evade NATO defenses by flying at low altitudes.
- The Soviet reliance on deep attack by medium bombers, which are relatively large and unmaneuverable, and hence particularly vulnerable to SAMs and fighters unless properly supported.
- The lack of fighter escort for any bombers used in attacks against the United Kingdom.
- The proliferation of hardened aircraft shelters at NATO airbases would force the Soviets to concentrate on closing runways, which would require more air raids over a longer period of time and hence greater exposure to NATO air defenses.
- The Soviets do not have enough hardened shelters to protect most of the aircraft that would deploy forward from the western USSR in the event of a massive reinforcement. We doubt that a large-scale reinforcement by second-echelon front aviation would be likely under most circumstances, however, until the ground forces of the affected second-echelon fronts also deployed forward

If the Soviets chose to start the war with the air operation, we believe achievement of tactical surprise would be difficult. Warning of the attack could allow NATO sufficient time to launch most of its aircraft, exacerbating potential Pact aircraft attrition and making the NATO airfields less lucrative targets.

We believe the large number of aircraft that the Soviets would use in the massed air raids combined with the loss of control facilities during combat would strain Pact airspace management capabilities and lead to some confusion. Deterioration of command, control, and communications resulting from NATO air attacks would also lead to greater confusion during subsequent raids. Additionally, bad weather would limit the size and effectiveness of the air raids or even force the postponement of the air operation.

We have no evidence that the Soviets would plan to employ chemical weapons<sup>2</sup> during the air operations in the nonnuclear phase of a war with NATO. The use of chemical weapons is not a standard, integral feature of the nonnuclear phase of war. The Soviets probably calculate that large-scale use of chemical weapons would cause NATO to retaliate with nuclear weapons. However, because of the significant Soviet offensive capability, the prudent planner cannot discount their

<sup>2</sup> This subject will be addressed in SNIE 11/17-2-84, *The Soviet Offensive Chemical Warfare Threat to NATO*, and NIE 11/17-85, *Soviet Chemical and Biological Weapons Programs*.

use. While we judge chemical weapons would be employed massively only in the context of transition to the nuclear phase of war, should the success of the air operation be jeopardized by the use of conventional munitions only, the Soviets would consider the use of chemical weapons against selected targets during the nonnuclear phase.

Through the year 1995, the air forces of the Military Districts and Groups of Forces (MD/GOF) are expected to remain stable in overall size with a slight decrease in numbers of fighters and some growth in ground-attack elements. Though the current MD/GOF organization will remain mostly stable, the Soviets may introduce improved tactics and pursue expanded objectives within the context of the air operation.

Future air operations will reflect the advances in air technology and in operational art and tactics, and are expected to differ from current operations only by degree. We believe the new-generation ground attack aircraft will pose a greater threat to NATO airfields because of their ability to carry improved standoff munitions, low-altitude penetration capabilities, improved onboard and escort electronic warfare systems, better navigation systems and sensors for adverse weather attack, and air-to-air refueling capability for extended range. This enhanced attack capability will require fewer aircraft to achieve desired target damage criteria/norms. In this way, the air operation will be able to maximize the effectiveness of aircraft available to the Soviet planner.

Concerning munitions, we believe future Soviet tactical air-to-surface missiles will have increased launch ranges, improved accuracy, and improved night and adverse weather capability. The Soviets will deploy more effective munitions for airfield attack, including a dual-stage runway-penetrator bomb for increased runway damage, aerially delivered mines to hinder runway repairs, and precision-guided bombs with electro-optical seekers for attacking high-value point targets.

We believe the Soviets will continue to face complicated command and control problems in mass air operations in the Central Region, with future air combat control requiring real-time knowledge of the status and location of both friendly and enemy aerodynamic assets. The Soviets will increase both the capacity and capability of their air communications by large-scale use of digital data communication systems coupled to onboard computers and displays, and will continue to advance those technologies necessary to allow direct communication satellite access from airborne platforms, with emphasis upon expanding the number and types of aircraft with communication satellite capability.

The current SRBM nonnuclear threat to NATO airbases is marginal. The SS-22 and the Scud missile lack sufficient accuracy to be effective in a conventional airfield attack role. Further, the SS-22 would not constitute a significant threat to airfields because limited numbers will restrict it primarily to the nuclear role. While the more accurate SS-21 is available in sizable numbers and continues to be deployed, its short range restricts its participation in the air operation to attacking the forwardmost elements of NATO's air defense system.

The SRBM threat will grow during the period 1985-95 with the deployment of the improved SS-23, which will have the requisite range and accuracy (50 meters CEP) to attack airfields. The degree of this threat will depend on the numbers of the system deployed, on other competing targets, and on whether specialized airfield attack munitions are developed. Improvements to the SRBM force will give the Soviets an option to employ it in a pin-down attack against some critical airbases and for neutralization of air defense sites in penetration corridors. Such attacks could significantly improve the chance of success of the initial massed air raid. Overall, while SRBMs will probably play a greater role in the air operation, we do not believe they will become in Soviet eyes the primary instrument for gaining air superiority in the NATO Central Region.

We believe that, during the period of this Estimate, Soviet special purpose forces in the WTVD will constitute a significant threat to the airfields of the NATO Central Region, and would be inserted prior to and during hostilities to conduct missions of reconnaissance and sabotage against NATO airfields, air defense, nuclear delivery forces, and other associated facilities. The vast majority of Spetsnaz will not cross the border before the beginning of conventional hostilities, and the Soviets would rely on the confusion of war, and the opening of penetration corridors during the air operation, to allow insertion of Spetsnaz by aircraft.

We believe their primary missions are to search for difficult-to-locate mobile missiles and command posts, to monitor preparations at airfields for nuclear strikes by NATO, and to assess the effects of Soviet air and missile strikes. Consequently, we believe Spetsnaz direct attacks would be limited to a few airbases in the Central Region, if these forces are to perform their other, high-priority missions.

We believe airborne attacks against NATO main operating bases during the early phases of the air operation are unlikely unless the Soviets obtain air superiority over at least a major segment of the Central Region. More likely would be attacks by air assault troops on

small civilian and military airfields just in front of advancing Soviet forces to secure airheads. Although the VGK might opt for an airborne operation on the first or second day of the air operation, we believe the Soviets would wait until at least D+3 or later to ensure some degree of air superiority and availability of transport aircraft.

A significant development in operational employment and combat organization of Soviet Ground Forces has been the development and employment of tank-heavy exploitation forces at front and army levels called operational maneuver groups (OMGs)—a concept intended for high-speed offensive operations deep into the enemy rear area. OMG operations are planned to disrupt the stability of the enemy rear and the movement of enemy reserves, to destroy major weapon systems, and to facilitate the advance of the first echelon and the commitment of the second echelon. Specific targets include nuclear delivery systems and depots, airfields, critical terrain, river crossing sites, and command posts.

While the OMG is a major component of Soviet combined arms operations, we do not believe it is a major threat to NATO main operating bases in the early days of an attack. The OMG would become a threat only over a period of days following a successful commitment.

Although the Soviets are developing two significantly different types of long-range land-attack cruise missiles, current evidence leads us to believe these are nuclear equipped. By the early 1990s, Soviet long-range cruise missiles will probably have improved CEPs (10 to 30 meters with area correlator update). Cruise missiles with nonnuclear warheads would facilitate attacks against airfields, air defense systems, and command and control facilities, but we cannot assess the likelihood at this time.

Within the last several years the Soviets have been experimenting with the reconnaissance strike complex (RSC) system, which appears designed to counter US long-range artillery systems delivering precision-guided munitions or submunitions. We believe it is unlikely that the Soviets would use RSCs to attack NATO airfields. Virtually all NATO military airfields already are known to the Soviets.

Although unlikely, certain Soviet SAM systems could possibly be employed in emergency situations in a surface-to-surface role. Surface-to-surface use would be inefficient and severely constrained by inadequate warheads and limited ranges. We believe the limited surface-to-

~~Top Secret RUFF~~

surface capability of the Soviet SAM systems does not presently pose a conventional threat to NATO airfields.

In summary, we believe that, for the period of this Estimate, the air threat will continue to be the single most significant threat to NATO airbases of the Central Region, followed by the SRBM and Spetsnaz threats. We believe that in the future the Soviets will be able to project airpower deeper into NATO's rear areas through advanced aircraft and weaponry operating under more effective and higher capacity command, control, and communications systems.

## DISCUSSION

## I. INTRODUCTION

## A. General

1. This Estimate examines the Warsaw Pact nonnuclear threat to NATO airbases in the Central Region. Succeeding chapters address the threat posed by Pact air forces, surface-to-surface missiles, special-purpose forces (Spetsnaz), cruise missiles, and airborne and air assault forces. The final chapter integrates the various threat elements in an illustrative scenario, depicting likely Pact actions against NATO airfields in the early (nonnuclear) phase of an attack. The Estimate also projects the threat into the 1990s to illustrate how it may evolve as the capabilities of the various threat elements develop.

2. Soviet planners regard NATO's tactical air forces in the Central Region as a formidable threat to their ground, air, and naval forces in a conventional conflict. The Soviets recognize that NATO's air assets provide the bulk of the NATO theater nuclear capability and that the success of NATO ground force operations is dependent upon tactical air support. The NATO Central Region contains the greatest concentration of airbases, air defense, and tactical nuclear assets in Western Europe. There are approximately 40 peacetime NATO airbases including 10 nuclear delivery bases, nine air defense bases, seven aerial ports of debarkation, and a number of collocated operating bases. (See figure 1.) Additionally, there are other air defense, nuclear, command, control, and communications, and logistics facilities that will also be competing targets. The Soviets consider the early attainment of air superiority and the destruction or neutralization of NATO's theater nuclear forces to be critical to the Pact's chances for victory in Europe. (See figure 2.)

3. The Soviets recognize that NATO would have to depend upon its tactical air forces to redress the imbalance in ground forces. In addition NATO tactical air forces are also a primary nuclear delivery means which the Pact would want to neutralize during the nonnuclear phase of the theater conflict. The Soviets have a nonnuclear operational concept, the air

operation,<sup>3</sup> designed to neutralize NATO air, air defense, and theater nuclear resources during the first several days of hostilities. The air operation is a combined arms operation with the air forces as the primary threat to NATO airbases. Supporting forces could include surface-to-surface missiles, artillery, Spetsnaz, airborne, and other assets. While the Soviets would hope to destroy NATO air and nuclear assets, the prevention of the early use of these assets might well be enough for them to regard a preemptive air operation as having fulfilled its objectives.

4. We have no evidence that the Soviets would plan to employ chemical weapons (CW)<sup>4</sup> during the air operations in the nonnuclear phase of a war with NATO. The use of chemical weapons is not a standard, integral feature of the nonnuclear phase of war. The Soviets probably calculate that large-scale use of chemical weapons would cause NATO to retaliate with nuclear weapons. However, because of the significant Soviet offensive capability, the prudent planner cannot discount their use. While we judge chemical weapons would be employed massively only in the context of transition to the nuclear phase of war, should the success of the air operation be jeopardized by the use of conventional munitions only, the Soviets would consider the use of chemical weapons against selected targets during the nonnuclear phase.

B. Warsaw Pact Concepts for a War Against NATO in Europe<sup>5</sup>

5. The Soviets plan to conduct a Theater Strategic Operation (TSO) against NATO in Central Europe, an

<sup>3</sup> For the purpose of this Estimate, the term "the air operation" refers to the initial air operation involving multiple massed air raids conducted over a period of several days during the initial phase of hostilities.

<sup>4</sup> This subject will be addressed in SNIE 11/17-2-84, *The Soviet Offensive Chemical Warfare Threat to NATO*, and NIE 11/17-85, *Soviet Chemical and Biological Weapons Program*.

<sup>5</sup> For more detailed discussion of Warsaw Pact concepts for a war against NATO in Europe, organization of forces, and command structure, refer to NIE 11-14-81D, *Warsaw Pact Forces Opposite NATO*, January 1982, and IIM, *Employment of Warsaw Pact Forces Against NATO*, July 1983.

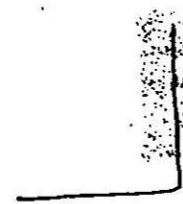
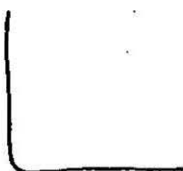
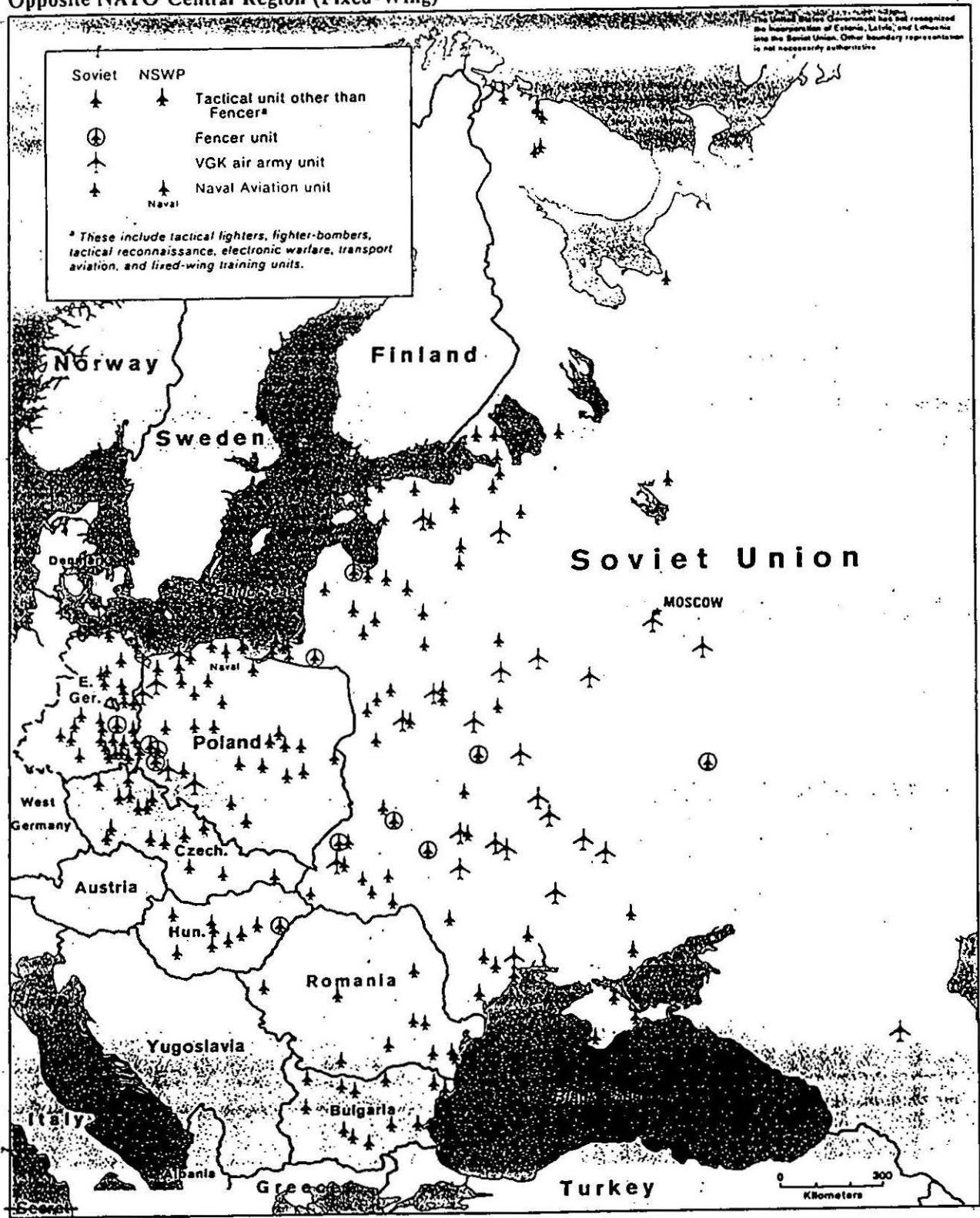




Figure 2  
 Peacetime Locations on Warsaw Pact Air Units  
 Opposite NATO Central Region (Fixed-Wing)



area the Soviets describe as the Western Theater of Military Operations (WTVD). It would be characterized by multiple, successive front operations, with few or no pauses, supported by Strategic Air Forces, Strategic Rocket Forces (SRF), and the Baltic Fleet. It would be conducted across a width of 700 to 750 kilometers and to a depth of 1,000 to 1,200 km under a single high command of forces in the TVD. The Soviets plan to complete this operation in 20 to 30 days.

6. We would also expect that, concurrently with initiating a theater strategic operation against NATO in Central Europe, the Soviets would launch attacks against NATO's northern and southern regions. We believe that the Pact would be unlikely to attack with major ground offensives against all NATO regions simultaneously. However, the Pact almost certainly would conduct secondary offensives or holding actions in the flank areas to keep NATO from shifting forces from the flanks to Central Europe, to compel commitment of NATO reserves, and to weaken NATO forces on the flanks in anticipation of further operations. Similarly, we would expect some simultaneous air operations against key NATO airfield complexes in Norway, although more limited than those against the NATO Central Region. Such actions would be designed to establish air superiority over the Norwegian Sea and adjacent waters to reduce the vulnerability of air and naval operations in the area.

## II. WARSAW PACT AIR FORCE STRUCTURE AND THREAT TO NATO CENTRAL REGION AIRFIELDS

### A. Tasks

7. Pact military planners assign their air forces three general tasks for conventional war in a continental TVD—to gain and maintain air superiority, to destroy the nuclear delivery capability of the enemy, and to support the ground forces. Soviet theorists believe the initial task is to obtain air superiority; however, the destruction of NATO nuclear delivery means and associated facilities would be carried out simultaneously. Although the Soviets recognize that the battle for air superiority would be continuous, the first several days of hostilities appear to be critical in their planning. During this period they would commit the bulk of their air forces to the air operation in a theaterwide attack against NATO airfields and air defense installations as well as attacks against surface-to-surface missiles, nuclear-capable artillery, and com-

mand, control, and communications facilities. Other theater support roles for the air forces would include close air support, neutralization of enemy reserves, aerial reconnaissance, electronic warfare, airdrop/air-landing operations, and airlift of supplies

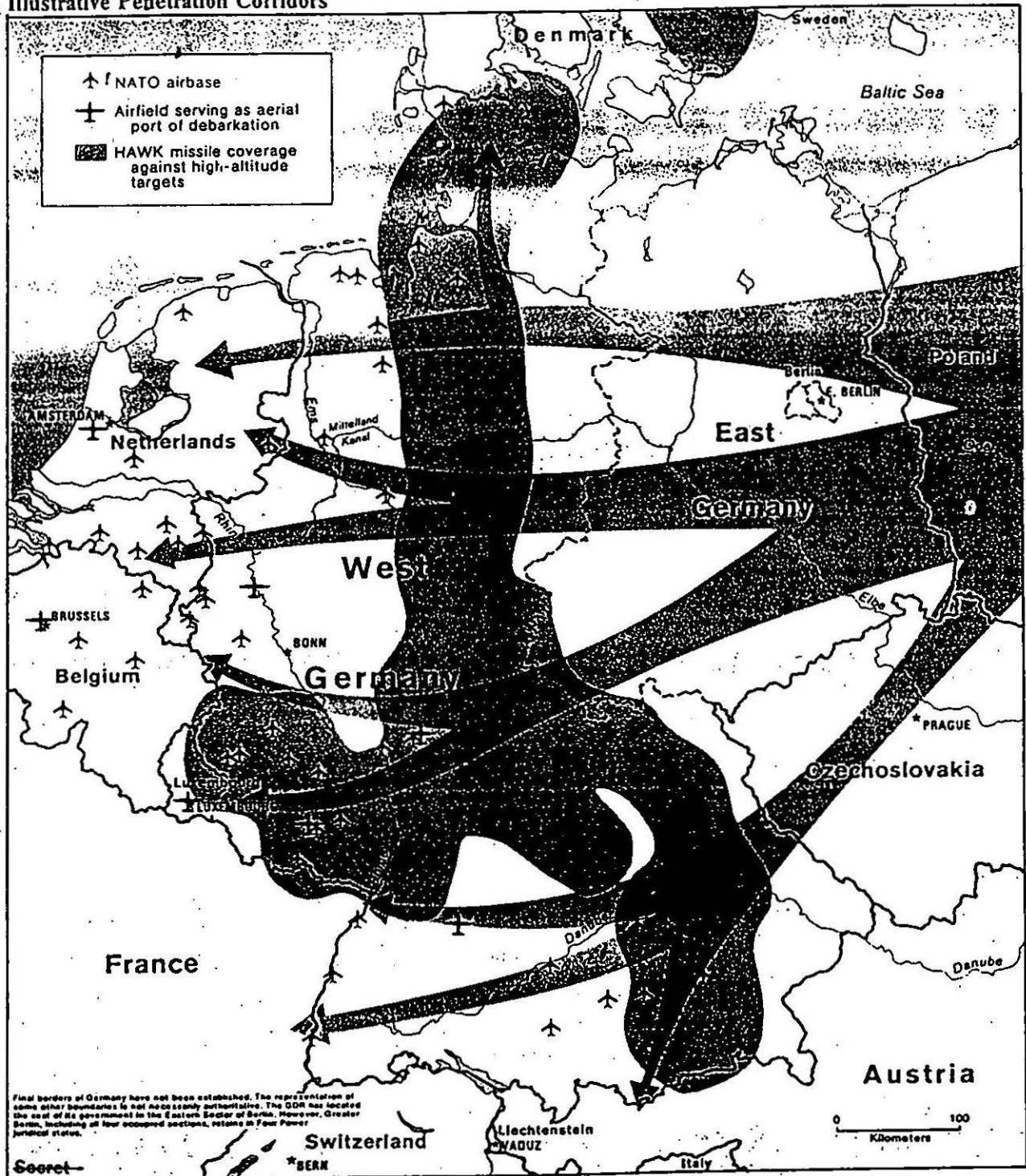
8. The Soviet General Staff, acting as executive agent for the Supreme High Command (VGK), would perform the initial planning and allocation of VGK assets, conduct strategic reconnaissance and reallocate air forces among TVDs, if necessary. The High Command of the Western TVD would conduct the detailed planning and direct the theater air operation.

9. Pact planners regard destruction of NATO aircraft as the primary means of gaining air superiority, and they expect airfield attacks to account for many of the aircraft NATO would lose during the air operation. In an attempt to destroy/neutralize NATO's nuclear capability, the Pact would concentrate attacks on those bases from which it expects nuclear delivery aircraft to operate. Pact planners would also assign high priority to bases housing air defense fighters.

10. The principal characteristics of the air operation against NATO's Central Region are likely to be:

- The Pact would most likely commit elements of two to four strategic air armies, three to five front air forces, including non-Soviet Warsaw Pact (NSWP) air forces, and various air defense, transport, and naval aviation units in a series of major air raids designed to achieve as much tactical surprise as possible.
- Each major raid would begin with a concerted effort to establish corridors through NATO air defenses, which Pact aircraft would then use to attack airfields, SSM launchers, nuclear-weapons storage facilities, command, control, and communications facilities, and other priority targets. (See figure 3).
- SU-24 Fencers and Soviet medium bombers would constitute the primary force for attacking airfields and, possibly, nuclear storage facilities.
- Fighter-bombers from the air forces of the fronts would be used to suppress air defenses and to attack fixed installations (to include airfields) and surface-to-surface missile (SSM) launchers. Other tactical and strategic aircraft would provide fighter cover, escort, reconnaissance and radio-electronic combat (REC) missions. NSWP air defense fighters would provide air defense of their homelands.

Figure 3  
Illustrative Penetration Corridors



~~Secret~~  
FOUO (544244) 10-84

- Aircraft operations would be supported primarily by employment of short-range ballistic missiles (SRBMs), artillery, and Spetsnaz. Attacks would focus on critical surface-to-air missile (SAM) sites, command, control, and communications sites, and airbases within range.
- Some Soviet and NSWP bomber, fighter-bomber, and fighter aircraft would be withheld for nuclear operations.

11. In general, the Pact would have available 2,600 to 4,100 fixed-wing aircraft to draw upon for operations against the NATO Central Region (see table 1).<sup>a</sup> The number of aircraft available for the first massed raid of the air operation would vary according to the extent to which the Pact moved additional tactical and strategic air units within range of NATO targets. The Pact probably has contingency plans for initiating the air operation from a variety of different postures ranging from employing in-place forces to moving additional aircraft to bases within striking range of NATO targets prior to, coincident with, or after launching the initial assault. During the execution of the air operation, most of the air support for front ground operations would be provided by helicopters.

12. [ ] variation of the air operation that the Soviets call an air defense operation. Its purpose is to blunt a major NATO air offensive and attrite NATO air assets, thus creating favorable conditions for the air operation—which still is intended to complete the defeat of Allied Air Forces Central Europe (AAFCE). We estimate the Soviets [ ] a belief that under certain circumstances an offensive air operation might not succeed.

13. An air defense operation differs from the air operation in that it requires a near-maximum air defense effort conducted simultaneously with numerous attacks of smaller scale against NATO airbases. The defensive portion of the operation would feature a large segment of the Warsaw Pact fighter force (perhaps about a third) engaging the lead elements of

<sup>a</sup> The lower figure (2,600) includes Warsaw Pact aircraft of Central Europe, including the Legnica and Smolensk Air Armies, the Baltic Fleet Naval Air Force, and tactical assets of East Germany, Poland, and Czechoslovakia. The higher figure (4,100) includes assets of the three western MDs and the Vinnitsa Air Army. Not included are the NSWP air defense interceptors (780). Aircraft to be withheld for nuclear reserve initially could range from 5 to 15 percent. These percentages would increase depending on Soviet perceptions of the imminence of nuclear escalation by either side.

**Table 1**  
Warsaw Pact Fixed-Wing Combat Aircraft Available for Use in the Air Operation in the Western Theater of Military Operations • August 1984

Origin	Type	Number
<b>Primary participants</b>		
GSFC, CGF, Legnica AA, Smolensk AA, Baltic Fleet, and East German, Polish, Czechoslovak tactical Air Forces	Fighters	778
	Fighter-bombers	771
	Fencers	210
	Medium bombers	514
	Reconnaissance/ECM	358
	<b>Subtotal</b>	<b>2,631</b>
<b>Probable participant if not committed to SWTVD</b>		
Vinnitsa Air Army	Fighters	135
	Fencers	180
	Reconnaissance/ECM	46
	<b>Subtotal</b>	<b>361</b>
	<b>Total</b>	<b>2,992</b>
<b>Possible participants if Soviet Second-Echelon Front aviation participates</b>		
Baltic Military District, Belorussian Military District, Carpathian Military District	Fighters	554
	Fighter-bombers	495
	Fencers	—
	Reconnaissance/ECM	62
	<b>Subtotal</b>	<b>1,111</b>
<b>Total</b>	<b>4,103</b>	
<b>Likely nonparticipants</b>		
East German, Polish, Czechoslovak air defense aircraft	Strategic interceptors	781
<b>Total</b>	<b>4,884</b>	

<sup>a</sup> Only about 85 percent of these totals would be available for sustained operations.

—This table is Secret—

NATO's attack force as it entered Pact airspace. Most of the other Pact fighters and part of the fighter-bombers would be used to intercept subsequent groups of NATO aircraft at a series of sequential intercept lines extending to the depth of the Pact rear.

14. Meanwhile, Pact ground attack aircraft would attempt to cut penetration corridors through NATO's

forward air defenses and then mine or crater the runways of key NATO airbases. The bulk of the Pact ground-attack aircraft would then be directed from aerial holdings zones to attack returning NATO aircraft in the open at alternate airfields. [

] Pact military writings indicate the planners believe air defense operations could continue for as many as six days. However, it must be noted that the air defense operation faces problems in execution. These include command and control and limited endurance of current Soviet attack aircraft.

15. DIA and NSA believe that, given Soviet military doctrine which stresses the importance of the offensive, initiative, and surprise to the success of military operations, the Soviets, faced with impending hostilities, plan to employ an offensive air operation against NATO rather than allow NATO air forces to attack first. [

] Allowing NATO air forces to attack first and conduct follow-up raids for two to three days has the potential to severely degrade Soviet command, control, and communications and aircraft assets to a point where the Soviet ability to make the transition to a massed offensive air operation would be in doubt. Further, additional execution problems, such as the lack of a lookdown/shutdown fighter force to engage NATO low-altitude penetrators and the absence of an air refueling capability for ground attack aircraft in the holding zones, preclude the effective employment of this air defense concept before 1990.

#### B. Forces

16. For offensive air operations in Central Europe, the Warsaw Pact could draw from:

- Strategic Aviation.
- Soviet Air Forces of the Groups of Forces in East Germany and Czechoslovakia and the three Western military districts.
- National air forces of East Germany, Czechoslovakia, and Poland.
- Baltic Fleet Air Force (see table 2).

The High Command of Forces in the WTVD would receive the support of the strategic aviation aircraft assigned to the 4th VGK Air Army in Poland and the Baltic Military District (MD), the 46th VGK Air Army in various bases in the western military districts, and in some cases elements of the 24th VGK Air Army (mostly in the Kiev, Belorussian, and Carpathian MDs) and possibly some of the 37th Air Army (bases throughout the USSR). We believe that elements of the 24th VGK Air Army as well as aircraft of the Baltic Fleet air force probably would be employed in operations against NATO's Central Region in the first days of a NATO-Pact conflict. Although some air units of the Baltic, Belorussia, and Carpathian Military Districts could be moved forward to support the initial air offensive, we believe it probable that the majority would remain in the western USSR at the outbreak of hostilities, and then move forward as required.

#### C. Command, Control, and Communications

17. We believe the Soviets continue to face complicated command and control problems in mass air operations in the Central Region. The current Soviet Air Force command and control is supported by HF, VHF, and UHF communications systems. Future air combat control will require real-time knowledge of the status and location of both friendly and enemy aerodynamic assets. An integrated targeting network would be required for target tracking, hand off, and engagement. The Soviets will continue to maintain a vigorous research and development program to upgrade their command, control, and communications systems and emphasize communication security.

18. We expect the Soviets will increase both the capacity and capability of their air communications by large-scale use of digital data communications systems coupled to onboard computers and displays. Airborne use of communication satellites will enhance air communication flexibility and permit high-capacity communications to take place over paths longer than currently obtainable with ground-based line-of-sight communications systems. By 1990 millimeter wave air-to-air communications systems could be available to provide range-limited transmissions within such formations as fighter attack groups.

19. The Soviets will continue to advance those technologies necessary to allow direct communication satellite access from airborne platforms. Future emphasis will be placed on expanding the number and types of aircraft with communication satellite capabil-

Table 2  
Warsaw Pact Fixed-Wing Combat Aircraft Available  
for Use in the Air Operation in the Western Theater  
of Military Operations, August 1984

	Fighters	Fighter-Bombers	Fencer Type	Medium Bomber	Reconnaissance/ECM	Total
GSFG	310	320	30	0	40	700
CGF	70	0	0	0	15	85
Legnica AA	135	0	180	0	40	355
Smolensk AA	0	0	0	410/ 315 <sup>a b</sup>	100/ 190 <sup>a b</sup>	510/ 505 <sup>b</sup>
Baltic Fleet	0	40	0	100	35	175
East Germany	0	40	0		15	55
Poland	110	225	0		55	390
Czechoslovakia	120	170	0		65	355
Subtotal	745	795	210	510/ 415 <sup>b</sup>	385/ 455 <sup>b</sup>	2,625/ 2,620 <sup>b</sup>
Vinnitsa AA	135	0	180	0	65	380
Subtotal	880	795	390	510/ 415 <sup>b</sup>	430/ 520 <sup>b</sup>	3,005/ 3,000 <sup>b</sup>
Baltic Military District	225	180	15	0	20	440
Belorussian Military District	205	135	0	0	30	370
Carpathian Military District	125	180	0	0	30	335
Subtotal	555	495	15	0	80	1,145
Total	1,435	1,290	405	510/ 415 <sup>b</sup>	510/ 600 <sup>b</sup>	4,150/ 4,145 <sup>b</sup>
East German Strategic Interceptors	300	0	0	0	0	300
Polish Strategic Interceptors	310	0	0	0	0	310
Czechoslovak Strategic Interceptors	170	0	0	0	0	170
Subtotal	780	0	0	0	0	780
Total	2,215	1,290	405	510/ 415 <sup>b</sup>	510/ 600 <sup>b</sup>	4,930/ 4,925 <sup>b</sup>

<sup>a</sup> CIA believes that approximately 100 Badger and Blinder aircraft estimated by DIA to have a primary strike role have primary missions of electronic warfare and reconnaissance.

<sup>b</sup> Dual figures reflect DIA/CIA differences.

~~This table is Secret~~

ity. The advent of direct broadcast satellites, expected shortly, will enable aerodynamic systems to pass data to individual ground units over almost limitless ranges.

#### D. Conventional Munitions

20. Soviet conventional munitions design philosophy has traditionally emphasized simplicity, minimum expense, reliability, and gradual evolution despite a technology base adequate to develop more complex

and costlier weapons. We estimate that the more complex weapons will be introduced in an evolutionary manner. In the 1990s, there will be smaller, smarter ordnance with increased effectiveness (see chapter VIII).

21. *Bombs.* The Soviets currently have a wide variety of gravity bombs. They have standardized their various bomb families into six weight classes (50, 100, 250, 500, 1,500, and 3,000 kilograms) of which two—the 250- and 500-kg classes—are most frequent-

ly used. General purpose and fragmentation bombs are available in both low-drag and high-drag versions. The high-drag versions are retarded by ballistic drag rings or parachutes. The parachute-retarded bombs are believed to be suitable for release from 50 to 500 meters above ground level.

22. The Soviets are assessed to have a runway penetration bomb consisting of a parachute retardation assembly, booster rocket, and a concrete penetrating warhead. The retardation assembly serves to orient the bomb downward to minimize ricochet and to provide for low-altitude (300 meters) operation. The rocket motor, possibly ignited by a pyrotechnic delay, burns away the parachute and accelerates the warhead. The warhead is designed to perforate the pavement and descend into the base below. The warhead, provided with a short delay train fuzing, is expected to detonate below the pavement, producing extensive cracking, buckling, and heaving of the runway. The assessed physical characteristics and performance for the runway penetration bomb are presented in table 3.

23. The Soviets are also assessed to have deployed a 500-kg semiactive laser-guided bomb using the same technology (for example, optics, guidance, and control) as is used with the AS-10 guided missile. This bomb can be employed with either a ground-based or airborne target designator and is capable of being released in level flight, in a dive, or in a dive toss maneuver. It could be used with any aircraft capable of carrying a 500-kg store and is assessed to use a FAB-500 bomb warhead and to be capable of CEPs of 5 to

**Table 3**  
**Estimated Runway Penetration Bomb**  
**Characteristics**

Length	2,500 millimeters
Weight	250 kilograms
Warhead weight	150 kilograms
High-explosive (TNT) weight	35 kilograms
Impact velocity	260 meters per second
Angle of impact	45 to 55 degrees
Penetration, maximum <sup>a</sup>	1.5 meters
Crater diameter size <sup>b</sup>	3 to 5 meters
Radius of pavement damage <sup>b</sup>	15 to 20 meters

<sup>a</sup> Perforate 0.5 meter reinforced concrete and 1 meter in base below.  
<sup>b</sup> In concrete.

~~This table is Secret.~~

10 meters. The guided bomb is intended for use against high-priority targets where accuracy is needed to ensure destruction. The Soviets are also assessed to have operational fuel air explosive (FAE) bombs in the 250- to 500-kg class that are assessed to be compatible with most Soviet aircraft

24. *Tactical Air-to-Surface Missiles (TASMs)*. Since 1971 the Soviets have produced and deployed eight tactical air-to-surface missiles (TASM) employing antiradiation homing (ARH), semiactive laser (SAL), beam rider, command, and recently electro-optical guidance systems. The current Soviet TASMs will probably be used as a baseline for the evolutionary development of future TASM systems possibly employing fiber optics, solid-state electronics, and more advanced electro-optical guidance systems as well as improved propulsion. Between now and the 1990s we expect lighter weight missile structures to be developed, providing for a higher warhead mass. Future TASM warhead design features will probably include shaped charges, self-forging fragments, reactive materials, smart mines, smart submunitions, and rocket-boosted kinetic energy penetrators. These systems and future TASMs could provide the Soviets an improved conventional air-to-surface missile capability for attacking NATO airfields and air defense systems and command, control, and communications facilities (see table 4).

25. The Soviets are now striving to develop new TASMs that provide greater launch ranges, lower launch altitudes, launch and leave, television guidance, improved accuracy against fixed and mobile targets, the ability to attack higher frequency radar and communications systems, all-weather operation, and operations in a countermeasures environment. The Soviets continue to emphasize TASM antiradiation munition (ARM) developments directed toward attacking surface-based air defense (AD) weapons and systems. As ARMs become smaller, lighter, and more economical, they will probably be considered for use against emitters such as troposcatter communications systems, other communications systems, battlefield surveillance radars, countermortar/counterbattery radars, jammers, navigational transmitters, and possibly airborne emitters as well (for example, early warning radar and data links).

#### E. Logistics and Support

26. Soviet logistic doctrine is based on a number of assumptions including the belief that a war in Europe would involve extremely high personnel and materiel losses, especially in the initial phase of a war, as well as

**Table 4**  
**Current Soviet Tactical Air-to-Surface Missiles (TASMs)**

	AS-7a	AS-7b	AS-9	AS-10	AS-11	AS-12	AS-13	AS-14
Initial operational capability	1971	1974	1975	1976	1978	1978	1984	1980
<b>Size</b>								
Length (meters)	3.5	3.5	6.0	3.7	5.0	4.2		3.8
Launch weight (kilograms)	290	290	715	290	620	300		600
Warhead weight (kilograms)	110 HE/FRAG	110 HE	155 HE	120 HE	100 HE	90 HE		300 HE
Guidance	Beam rider	CMD	ARH	SAL	ARH	ARH		SAL
Propulsion	Solid	Solid	Liquid	Solid	Solid	Solid		Solid
Carrier aircraft (maximum)	Fishbed-2	Flogger-4	Fencer-5	Flogger-4	Fencer-5	Flogger-2		Flogger-2
	Fitter-2	Fitter-2	Fitter-1	Fitter-2	Fitter-2	Fitter-2		Fitter-2
		Fencer-4		Fencer-4	Foxbat-2	Fencer-4		Fencer-4
		Forger-2		Frogfoot-8	Fulcrum-2			Frogfoot-4
	Frogfoot-8			Flanker-2				

high consumption rates for supplies, particularly ammunition and fuel. The Soviets also assume that supply lines would be extended and vulnerable to enemy air attacks and long-range weapons. Soviet logistic procedures are governed by a number of basic principles including centralized planning, priority to combat supplies, forward distribution, use of all possible resources, and general reliance on rail transportation.

27. The Soviet air logistic system is geared to support a short-term (less than 90 days), high-intensity war, and relies heavily on peacetime storage and stockpiling of ammunition, POL (petroleum, oil, and lubricants), and air technical supplies. Over the past few years, however, a substantial increase in POL and ordnance storage capacities at airfields and in rear-area depots has greatly enhanced the capability of the

Soviet Air Force to support sustained combat. Throughout the Western Theater of Military Operations, the Soviets have established a network of fixed depots that have been assessed to contain sufficient supply stocks to support an initial three-front operation and subsequent operations for at least three weeks of intensive combat operations, though with steadily declining sortie rates. Reserves from central depots in rear areas—if not required elsewhere—should be available to support sustained combat operations for about three months.

28. It is believed that most Soviet airbases in the forward area are capable of logistically sustaining three to seven days of combat operations. In a combat situation, POL will most likely be transported by existing or temporary tactical pipelines to airfields.



POL storage sites located on airfields usually are bunkered or partially underground to minimize the damage from attack. Most of the main operating bases have been equipped with hydrant refueling, eliminating the need to refuel aircraft by truck. In addition, most later model aircraft bunkers allow for the fueling of aircraft within the bunker.

29. Ammunition stockpiles are dispersed throughout the Soviet Union and Groups of Forces (GOF). The larger facilities are both road and rail served with reveted open storage areas, warehouse/sheds, or bunkers. We believe that there may be three to four air-to-air missile loads for each aircraft at fighter bases, and one to two air-to-surface missile loads for each aircraft at tactical airbases with ground attack aircraft that have an air-to-surface missile (ASM) capability.

30. Ordnance is distributed to air units in peacetime primarily by rail, either directly to the airfield or to adjacent railheads, and by truck and air transport. Because both rail and road systems are vulnerable to interdiction, air transport, including helicopters, would become more important in wartime to assure prompt resupply of air units.

31. The Soviet Air Forces rely heavily for aircraft spare parts on the distribution of spare parts kits with each aircraft as it is delivered from the factory or overhaul facility. These kits include all spare parts and special tools required for normal maintenance up to the time of general overhaul, after which new kits are issued. Individual item requisitions are limited to replacing only those parts that fail, malfunction, or are damaged before the expiration of their guaranteed service life.

32. Common problems experienced with the supply of parts include inadequate spares to support a higher-than-anticipated consumption rate, poor distribution practices, low production quotas, and long leadtimes associated with ordering new parts. During wartime, operational air units would attempt to alleviate such problems by stockpiling parts which have a high use rate and resorting to cannibalization, particularly in a short war.

#### F. The Air Operation

33. The Soviets still regard the air operation as the primary means of establishing air supremacy and destroying or neutralizing NATO's nuclear capability. Overall responsibility for the air operation, a joint forces operation, is assigned to the high command in

the Western TVD. Nonetheless, the primary role in destroying NATO's air forces in conventional warfare remains with the Warsaw Pact air forces.

#### 34. Location and Timing of Attacks

At least the first few massed air raids of a conventional air operation in the Western TVD probably would be concentrated in the mid-European strategic zone and the North Sea. Most primary NATO targets lie in this area within 150 to 400 km of the West German-East German border and could be struck by strategic and naval aviation medium bombers flying low-altitude defense penetration flight profiles and by Fencers deployed or based in the forward area.

35. The Soviets also may intend to attack deeper targets, such as key airbases in France and the United Kingdom during the conventional air operation. Recent military writings state that the operation would cover an area about 1,000 km deep and 1,000 to 1,500 km wide—which would include almost all of Britain and most of France. The Soviets probably envision conducting most of the attacks against the deeper targets during the later phases of the operation, however, because according to Soviet planning factors, the only USSR-based aircraft capable of participating without first deploying to forward airbases would be medium or heavy bombers.

36. The timing of the individual massed air raids would be influenced by several operational constraints. Soviet military writers often have noted that achieving some degree of tactical surprise could be critical to success because it would allow the Pact to catch substantial numbers of NATO aircraft on the ground during the airfield attacks and would reduce Pact losses to NATO air defenses. Even though the Soviets have expressed interest in conducting air raids at night—for which strategic aviation units have trained—to enhance surprise and impair NATO's air defenses, military writers repeatedly have rejected this possibility. This rejection is because of front aviation's very limited training and target acquisition capabilities for offensive operations at night.

Their writings have noted that the initial massed raids could be spaced as little as seven hours apart, however, with the limiting factor being the time required for the preparation and transit of the medium-bomber force to their targets.

37. The heart of the air operation would be a series of airfield attacks designed to destroy a sufficient portion of NATO's air forces to establish strategic air supremacy as well as substantially reduce NATO's nuclear strike potential. Airbases housing fighter-bomber wings with nuclear strike roles generally are the top-priority targets [

] Fighter bases also would be attacked. Soviet military writings note that front aviation also would make small-scale attacks against NATO airfields between the massed air raids in support of front objectives.

38 [

] the preferred targets at NATO airfields would be aircraft in the open, but the proliferation of hardened aircraft shelters has caused the Soviets to concentrate much of their emphasis on cutting runways. They also appear to recognize that resorting to closing runways probably would require more repeat attacks to keep them closed. Their writings have indicated that hardened aircraft shelters would be attacked as well, but we believe that such attacks probably would be deferred to the later phases of the air operation because they require large numbers of aircraft—typically one attack aircraft per shelter. Airfield attack plans in some cases also have included key base support facilities such as maintenance, fuel, and ammunition storage areas. [

] **40. Potential Problems.** We believe the Soviets would find it extremely difficult to amass enough force to launch a strategic theaterwide air operation at

the outset of war with high expectations of a successful outcome should France fight with NATO or the United States deploy significant reinforcements to Central Europe. The Soviets' perceptions of the air balance are strongly influenced by their judgment that most Western aircraft enjoy a significant qualitative advantage over their Soviet counterparts

41. We believe that if aircraft attrition rates were substantially higher than the Soviets expect, the Soviets could be forced to cancel the air operation after only one or two massed air raids—before it accomplished its objective of attaining air supremacy. Factors affecting attrition rates would include:

- Higher-than-expected survivability of the ground-based segments of NATO's air defenses in the face of suppression attacks involving aircraft, SRBMs, and artillery.
- NATO airborne warning and control system (AWACS) aircraft and lockdown/shutdown fighters limiting opportunities for Pact aircraft to evade NATO defenses by flying at low altitudes.
- The Soviet reliance on deep attack by medium bombers, which are relatively large, unmaneuverable, and hence particularly vulnerable to SAMs and interceptors unless properly supported.
- The lack of fighter escort for any bombers used in attacks against the United Kingdom.
- The proliferation of hardened aircraft shelters at NATO airbases would force the Soviets to concentrate on closing runways requiring more air raids over a longer period of time and hence greater exposure to NATO air defenses.
- The Soviets do not have enough hardened shelters to protect most of the aircraft that would deploy forward from the western USSR in the event of a massive reinforcement. We doubt that a large-scale reinforcement by second-echelon front aviation would be likely under most circumstances, however, until the ground forces of the affected second-echelon fronts also deployed forward.

42. If the Soviets chose to start the war with the air operation, achievement of tactical surprise could be difficult. Further, if USSR-based medium bombers participated in the first massed air raid, they would have to take off from rear area bases one and a half to

two hours before the front air forces and could be detected by a combination of signals and infrared intelligence. Additionally, NATO AWACS could detect Pact aircraft as far as Poland, depending on the orbit. Warning of the attack could allow NATO sufficient time to launch most of its aircraft, exacerbating potential Pact aircraft attrition and making the NATO airfields less lucrative targets.

43. If NATO were able to launch large numbers of aircraft before the Pact attack, the Pact would have to rely heavily on fighter sweeps and escorts to destroy them. Pact air forces are poorly equipped to conduct fighter sweeps over NATO rear areas, however, because of limitations in the air intercept radars and missiles on their Flogger and Fishbed fighters. This problem could be partially rectified in the late 1980s and early 1990s with the deployment of substantial numbers of the SU-27 Flanker (and to a lesser extent MIG-29 Fulcrum) AWACS aircraft, Candid tankers, and an all-aspect infrared-guided air-to-air missile.

44. Finally, the large number of aircraft that the Soviets intend to use in the first massed air raid probably would strain Pact airspace management capabilities and lead to some confusion. Deterioration of command, control, and communications resulting from NATO air attacks would lead to even greater confusion in subsequent Pact raids. Additionally, bad weather would limit the size and effectiveness of the air raids or even force the postponement of the air operation.

#### G. Future Developments

45. Through the year 1995 the air forces of the military districts and groups of forces are expected to remain stable in overall size with a slight decrease in numbers of fighters and some growth in ground attack elements. Though the current MD/GOF organization will remain mostly stable, the Soviets may introduce improved tactics and pursue expanded objectives. Most changes in the MD/GOF aviation forces will be evolutionary in nature and occur as a result of advancing weapon system technology and the Soviet perceptions of the changing threat.

46. Some of the factors we estimate the Soviets use to plan the size, structure, and objectives of their future aviation forces include:

- US strategic air force capabilities.
- US and NATO cruise missile capabilities.
- NATO tactical air force capabilities.
- NATO air defense capabilities.

- NATO tactical and theater strategic nuclear force capabilities.
- Employment of Soviet AWACS in an offensive role.
- Soviet army aviation capabilities for close air support.
- New Soviet aircraft capabilities.
- The adoption of new tactics.
- The Sino-Soviet competition and the Chinese general purpose force capabilities.
- Soviet aerial refueling.

47. In the principal area of concern, Western Europe, the Soviets will continue to give high regard to the capabilities of the NATO tactical air forces, which they credit with the potential to blunt and disrupt a Warsaw Pact combined arms offensive aimed at NATO. We believe they will maintain this view through the mid-1990s and continue to respond with the planning and refinement of a more extensive and efficient air operation.

48. Future air operations will reflect the advances in air technology and in operational art and tactics, but are expected to differ only by degree. We believe the enhanced attack capability of new MD/GOF and Strategic Aviation aircraft will require fewer aircraft to achieve desired target damage criteria/norms. In this way, the air operation will be able to maximize the effectiveness of aircraft available to the Soviet planner.

49. Another factor which is expected to influence Soviet tailoring of the air forces will be the advanced design features and performance capabilities of the new aircraft deployed between now and 1995. We believe these new-generation aircraft will pose a greater threat to NATO airfields because of their ability to carry improved stand-off munitions, low altitude penetration capabilities, better navigation systems and sensors for adverse weather attack, and air-to-air refueling capability for extended range. Improvements in aircraft reconnaissance systems are expected to include the expanded use of remotely piloted vehicles/drones.

50. During the next decade more Soviet aircraft will be equipped with onboard self-protection electronic warfare (EW) systems. In the escort role, the imminent deployment of electronic countermeasures (ECM) Fencer will give the Soviets a more credible capability to provide EW support for air raids in

NATO's rear areas. The combination of improved onboard and escort EW systems will significantly enhance Soviet penetration capabilities.

51. During the next 10 years we believe the Soviets will give emphasis to reequipment of the Soviet air forces based in East Europe, and in this period we expect the non-Soviet Warsaw Pact countries gradually to modernize their forces as well. The pace of the NSWP modernization will be much slower and limited to those systems the Soviets are willing to release/sell to their East European allies and which they can afford to purchase. However, we anticipate progress in phasing out the older generation aircraft and broader introduction of newer aircraft. We believe the NSWP countries will receive the new generation Fulcrum aircraft about 1990. The NSWP countries will also attempt to expand and modernize their ground attack capabilities in order to provide better support for their own ground forces.

52. We believe the number of aircraft in future fighter and fighter-bomber regiments for almost all types of new generation aircraft will be reduced but that the three-squadron regimental structure will remain. The number and type of aircraft per regiment will be determined by the Soviet estimate of the effectiveness of the new aircraft. Aircraft inventories (table 5) of the different types of units will vary according to the type aircraft assigned, but the required operational readiness rate will remain at least 85 percent.

### III. SHORT-RANGE BALLISTIC MISSILES

#### A. General

53. Over the past 20 years, the Soviet Union has strived to improve the range, accuracy, and readiness of its SRBM systems. In the late 1950s, the Soviets developed the FROG-7, Scud B,<sup>1</sup> and SS-12 SRBMs, which provided most of the Ground Forces nuclear striking power throughout the 1960s and 1970s. During the mid-to-late 1960s, the Soviets began development of two new SRBMs, the SS-21 and SS-23, to replace the FROG-7 and Scud B, and the SS-22,<sup>2</sup> an

<sup>1</sup> CIA believes that the Soviets began to deploy improved versions of the SS-12 Scud-B missile beginning in the late 1960s. These newer versions probably have improved accuracy and maintainability, and one of them probably has a range of 500 km. Furthermore, CIA believes that Scuds are still in production and will remain in service well into the 1990s.

<sup>2</sup> The US Weapons and Space Systems Intelligence Committee proposes to retire the SS-22 missile system designator and assign Mod 1 and Mod 2 designators to the SS-12. The SS-12 Mod 2 designator would be assigned to the improved accuracy variant of the SS-12 which has carried the SS-22 designator.

improved version of the SS-12 (Scaleboard). These three systems are more capable than their predecessors (see table 6), and two of them, the SS-21 and SS-22, are now being deployed. They can all deliver nuclear as well as nonnuclear warheads (for example, chemical, high-explosive, and improved conventional munitions (ICM)). Although nuclear delivery remains a major role, SRBMs with improved accuracy and with nonnuclear warheads become more effective and attractive for use against fixed and mobile targets to include airfields and air defense facilities.

54. [ the Soviets are continuing their efforts to increase SRBM system effectiveness. ]

[ terminal guidance ] may be incorporated into modernized versions of SRBMs now in production, and almost certainly will be incorporated into follow-on SRBMs at least by 1990. The current reaction times (completion of road march to launch) of the SS-21 and SS-23 are assessed to be 15 to 20 minutes and 15 to 30 minutes, respectively. [ an SS-21 may be able to launch in as few as six minutes from the road march and can probably displace in three minutes or less. We estimate the Scud may be able to displace in three to five minutes. The SS-23 may be able to displace in four minutes or less. However, individual crew proficiency may lengthen or shorten these times. ]

#### B. Force Development

55. The Soviets classify missiles primarily by operational range. Tactical missiles (or rockets) include the FROG series and the SS-21. Operational-tactical missiles include the Scud series, the SS-22, and the SS-23.

56. The Soviets have committed substantial resources to the development of new or improved SRBMs employing improved inertial or terminal guidance, propulsion, and warhead technology. Available data on these systems reflect a definite trend toward improved accuracy, greater range, reduced reaction time, increased reliability and survivability, and broader warhead options, particularly with conventional munitions.

57. Through the early-to-mid-1960s, Soviet writings emphasized that the principal role for tactical and operational-tactical SRBMs was as the main nuclear

Table 5  
Warsaw Pact Fixed-Wing Combat Aircraft Available  
for Use in the-Air Operation in the Western  
Theater of Military Operations, 1995

	Fighters	Fighter-Bombers	Fencer Type	Medium Bomber	Reconnaissance/ECM	Total
GSFC	240	310	30	0	100	680
CGF	120/80 *	0	0	0	15	135/95 *
Legnica AA	100	0	180/270 *	0	60	340/430 *
Smolensk AA	0	0	0	325/180 *	60	385/240 *
Baltic Fleet	0	40	0	60	25	125
East Germany	0	50	0	0	15	65
Poland	110	210	0	0	75	395
Czechoslovakia	105	155	0	0	75	335
Subtotal	675/635 *	765	210/300 *	385/240 *	425	2,460/2,365 *
Vinnitsa AA	100	0	180	0	45	325
Subtotal	775/735 *	765	390/480 *	385/240 *	470	2,785/2,690 *
Baltic Military District	240	120	30	0	40	430
Belorussian Military District	240	120	60/30 *	0	45	465/435 *
Carpathian Military District	160/120 *	120/175 *	60/0 *	0	40	380/335 *
Subtotal	640/600 *	360/415 *	150/60 *	0	125	1,275/1,200 *
Total	1,415/1,335 *	1,125/1,180 *	540	385/240 *	595	4,060/3,890 *
GDR Strategic Interceptors	320	0	0	0	0	320
Polish Strategic Interceptors	310	0	0	0	0	310
Czechoslovak Strategic Interceptors	145	0	0	0	0	145
Subtotal	775	0	0	0	0	775
Total	2,190/2,110 *	1,125/1,180 *	540	385/240 *	595	4,835/4,665 *

\* Dual figures reflect DIA/CIA differences.

~~This table is Secret~~

delivery means of the ground maneuver forces. However, by the late 1960s, an additional role of SRBMs could be noted in Soviet theoretical writings. Although nuclear delivery remained the primary role, serious consideration was being given to the employment of SRBMs in a conventional role as well.

58. From the Soviet book entitled *Artillery and Rockets* (ed. Marshal of Artillery Kazakov), dated 1968, are listed these benefits of ICM-armed missiles in terms of range and destructive effect:

- Replacement of a 500- to 1,000-kg warhead with a quantity of submunitions of total equal weight increases the total area of destruction of a single missile.
- The submunitions may be of the most diverse types and destructive power: fragmentation, ar-

mor piercing, shaped charge, incendiary, smoke, and others.

- The destructive effect of a single ICM warhead equates to the simultaneous salvo of 40 to 100 or more artillery pieces

59. [

Use of ICM warheads will depend on the priority of ]

**Table 6**  
**Technical Characteristics of Soviet SRBMs**

	FROG 7A/B	SS-21 Mod 1	SS-21 Mod 2	SS-1c * Scud	SS-23	Improved SS-23	SS-12	SS-22	Improved SS-22
Initial operational capability	1965/69	1976	1981- 1983 <sup>b</sup>	1961	1981 <sup>c</sup>	1985-1990 <sup>b</sup>	1965	1977	1985-90 <sup>b</sup>
Maximum range (kilometers)	65-70	80-100 <sup>d</sup>	80-100 <sup>d</sup>	300	500	500	900	900	900
Guidance	None	Inertial	Inertial	Inertial	Inertial	Inertial	Inertial	Inertial	Inertial
CEP (meters) <sup>e</sup>	380	200-300	35-50 <sup>a</sup>	500-900	250-350	50	600-800	300-400	50 <sup>b</sup>
Reaction time (minutes)	25-30	15-20	15-20	40	15-30	15-30	30-40	15-30	15-30
Retarget time (minutes)	15 <sup>f</sup>	10-15 <sup>g</sup>	10-15 <sup>g</sup>	20	10-15	10-15	15-45	15-45	15-45
Refire time (minutes)	10-12	45-55	45-55	90-150	45-55	45-55	60-120	60-120	60-120

Top Secret Ruff

25  
Top Secret

TOP SECRET 04

[Faint, illegible text enclosed in a large bracket-like shape]

BLANK PAGE



targets that must be neutralized, with nuclear assets, air defense sites, and command, control, and communications, and airfields having a high priority.

60. ICM warheads are referred to as "cassettes" which could include high-explosive, armor and concrete piercing, mines, and chemical submunitions.

61. Current information indicates that the Soviets plan for multiple roles and fire support missions for their SRBM force. Their ability to employ SRBMs against a broad target array and obtain the required or desired target damage is dependent on such factors as: (1) the technical characteristics of the missiles, warheads, and ground support equipment; (2) available forces and dispositions; (3) logistics posture, including support units and missile and warhead stocks; (4) target detection and location capabilities; and (5) a command, control, and communications system that provides for the timely allocation of assets and execution of strikes against operational requirements.

#### C. SRBM Force Structure in the Western TVD

62. Within the Western TVD there are approximately 700 SRBM transporter-erector-launchers

(TELs); of these launchers, 500 are in the Soviet forces and 200 are in the non-Soviet Warsaw Pact forces. (See table 7.)

63. A FROG or SS-21 battalion is normally subordinate to each tank or motorized rifle division and normally has two firing batteries, each with two TELs for a total of four TELs per battalion. Some NSWP FROG battalions have only two or three TELs.

64. Soviet SS-1c Scud brigades are subordinate to armies and fronts. A nominal Scud brigade has three firing battalions. Each firing battalion has two firing batteries, each with two TELs. In actuality, Scud brigades vary in structure from a six-TEL configuration in some NSWP brigades, to a high of 27 TELs in the two GSFG front-level brigades. When initially deployed, the SS-23 probably will replace the Scud on a one-for-one basis.

65. The SS-22 in peacetime is subordinate to a military district or Group of Forces and in wartime will become an asset of the theater of military operations or front. In the fall of 1983, the Soviets indicated plans to establish SS-22 brigades in Central Europe in response to NATO's fielding Pershing II and ground-launched cruise missiles (GLCMs). Since then, one brigade has been established in Czechoslovakia and two in East Germany, at least one of which is an 18-TEL brigade.

66. Within the Intelligence Community there are varying opinions concerning the initial operational

Table 7  
Western TVD SRBM Launchers (August 1984)

	FROG-3/5	FROG-7	SS-21 Mod 2	Scud A/B	SS-22	Total
GSFG	0	24	56	114	30	224
NGF	0	8	0	18	0	26
CGF	0	20	0	12	12	44
Baltic Military District	0	36	0	12	0	48
Belorussian Military District	0	44	4	60	12	120
Carpathian Military District	0	40	8	36	0	84
East Germany	0	20	4	20	0	44
Poland	18	28	0	26	0	72
Czechoslovakia	6	30	0	28	0	64
Total	24	250	72	326	54	726

This table is Secret

capability (IOC)\* of the SS-21 Mod 2 and the projected IOCs of the improved versions of the SS-23 and SS-22.<sup>9</sup> The SRBM projections reflect the positions of DIA and Army, CIA, and the Air Force (see table 8).

using dedicated transport before or at the onset of hostilities. Missile and warhead transport capability indicates that two missiles and two warheads (an initial missile and one reload missile) are immediately available per TEL for SS-22 launch brigades. Available information indicates that, when the brigade vacates its garrison, each TEL will transport a missile to the dispersal area. These same sources have indicated that one missile for each TEL (without warhead) is stored on or near the TEL within the installation.

67.

70. We currently assess the number of missiles in launch units to be two missiles per launcher for Scud units, four missiles per launcher for FROG units, three missiles per launcher for SS-21 units, and two missiles per launcher for SS-22 brigades. On the basis of an assessment of the carrying capacity of Soviet and NSWP support units within the Western TVD, estimates of four to six missiles available per Scud and SS-21, four to eight per FROG, and two per SS-22 launchers are reasonable. This includes missiles in launch units, mobile rocket technical base (PRTBs), independent missile transport battalion (ORPDs), and front Rocket Technical Base (RTBs). Therefore, multiplying the number of launchers by these ranges, we arrive at an assessed missile inventory available on D-day that would be in launch units and the rear area support structure (see table 9).

68.

71. The warhead types associated with SRBMs are nuclear, unitary high explosive, subprojectile ICM, enhanced blast, and CW (see table 10). The possibility also exists for the deployment of ICM with runway penetrators, small and large area denial mines, and small antipersonnel bomblets. Any system capable of dispensing chemicals would be capable of dispensing biological agents.

72. *Warhead Allocation.* Information on missile warhead mix and stockage practices is very limited.

#### D. SRBM Missile Storage and Transport

69. Soviet readiness procedures call for all units to clear garrison areas and assemble at dispersal points,

\* A system will be considered to have reached an initial operating capability when it is judged to have completed a successful R&D test program, accomplished some training, been deployed at an operational site or on an operational platform, and is capable of performing its assigned mission (as defined by the Weapons and Space Systems Intelligence Committee).

<sup>9</sup> CIA believes there will be a follow-on to the SS-22 versus an improved variant.

**Table 8**  
**Western TVD SRBM Launcher Inventory Projections**

	1987			1990			1993			1995		
	DIA and Army	CIA	Air Force	DIA and Army	CIA	Air Force	DIA and Army	CIA	Air Force	DIA and Army	CIA	Air Force
FROC-3/5	40	32	29	24	20	28	8	8	13	4	4	10
FROC-7	218	210	158	196	180	113	184	136	100	148	128	108
SS-21 Mod 1 <sup>a</sup>	0	0	0	0	0	4	0	0	32	0	0	48
SS-21 Mod 2	146	154	164	190	198	220	224	260	236	272	280	236
Scud-B	214	430	249	164	344	156	106	178	98	86	104	80
SS-23	0	36	72	0	0	132	0	0	118	0	0	50
SS-23 Improved <sup>b</sup>	168	0	0	256	154	42	306	312	150	320	380	240
SS-22	0	126	48	0	126	0	0	36	12	0	0	0
SS-22 Improved <sup>b</sup>	54	0	0	90	0	48	90	0	36	90	0	48
SS-22 <sup>c</sup> follow-on	0	0	0	0	0	0	0	90	0	0	126	0
<b>Totals</b>	<b>840</b>	<b>988</b>	<b>720</b>	<b>920</b>	<b>1,022</b>	<b>741</b>	<b>918</b>	<b>1,020</b>	<b>795</b>	<b>920</b>	<b>1,022</b>	<b>810</b>

<sup>a</sup> Air Force believes the NSWP will be equipped with the SS-21 Mod 1 versus SS-21 Mod 2.

<sup>b</sup> DIA and Army believe the Improved SS-23 and the Improved SS-22 will reach IOC in 1985 and that there will be a more gradual expansion to 18 TEL brigades than projected by CIA. Air Force believes the expansion to 18 TEL brigades will be even more gradual. CIA and Air Force hold the IOC for the Improved SS-23 in the period 1988-90.

<sup>c</sup> CIA believes there will be a follow-on to the SS-22 versus an improved variant.

~~This table is Secret~~

**Table 9**  
**Assessed Missile Inventory in the Western TVD**  
**Available on D-Day (August 1984)**

	FROG		SS-21		Scud		SS-22	
	Launchers	Missiles	Launchers	Missiles	Launchers	Missiles	Launchers	Missiles
Groups of Forces	52	208-416	56	224-336	144	576-864	42	84
Non-Soviet Warsaw Pact	102	408-816	4	16-24	74	296-444	0	0
Western Military District	120	480-960	12	48-72	108	432-648	12	24
<b>Total</b>	<b>274</b>	<b>1,096-2,192</b>	<b>72</b>	<b>288-432</b>	<b>326</b>	<b>1,304-1,956</b>	<b>54</b>	<b>108</b>

~~This table is Secret~~

**Table 10**  
**Currently Assessed SRBM Warheads**

Warhead	FROG-7	SS-21 and Mod	Scud	SS-23 and Mod	SS-22 and Successor
	Nuclear/HE ICM/CW	Nuclear/HE ICM/CW	Nuclear/HE ICM/CW	Nuclear/HE ICM/CW	Nuclear/HE ICM/CW*
Yield					

\* Possible.

~~This table is Secret~~

It is assessed that, as the size and capabilities of the operational tactical missile force increase, the percentage of ICMs in the warhead mix will increase.

**E. Impact of Future Systems**

73. Although information on SRBM warheads is limited, future systems could employ any number of warhead types currently assessed to exist for other

Soviet delivery systems but not yet identified or associated with SRBMs. Currently, there is no direct evidence of the Soviets' developing "smart" submunitions for their SRBMs, however, precision-guided munitions (PGMs) are available for aircraft and artillery systems.

74. The development and deployment of improved SRBM airframes, guidance, improved range, warheads, and ground support equipment will provide more reliable, responsive, and flexible systems with enhanced survivability, enabling Warsaw Pact commanders to increase the role and missions of their SRBM systems with a higher assurance that operations can be executed successfully without the employment of nuclear weapons.

75. In terms of an air operation in the Western TVD, the Warsaw Pact will recognize multiple gains

execution of these plans could be disrupted, it is possible that the entire operation would be degraded.

— The Soviets, in an effort to deal with the complexity of their operations, apparently are improving the communications capabilities of their SRBM forces, beginning with the SS-22 brigades, and have increasingly computerized their targeting data base. Reliance on this computerized data base places a burden on the computer program and data to reflect a time-sensitive battlefield. If the computer system should fail, detailed calculations for the planning process would have to be done "by hand," detracting from the Soviets' ability to execute their plans on a fast-changing battlefield.

— *Support Operations.* The requirement for support units to keep pace during rapid offensive operations could degrade the capability of the support structure to provide ready-to-fire rounds. Front PRTBs and central depots are highly dependent on rail transport for receiving stocks from the rear. Successful interdiction of rail lines could seriously degrade the resupply of missiles for follow-on operations, although missiles and warheads can be delivered by air under emergency circumstances.

— *Battlefield Crowding/Disposition.* To bring to bear sufficient missiles to execute D-day strikes against priority targets in the NATO rear area, missile units would have to be deployed well forward. Because of geographic constraints, these systems could be heavily concentrated. Additionally, the heavy support structure required to service the missile units would be located in the proximity of other support units.

#### F. SRBM Threat Assessment

77. The current SRBM nonnuclear threat to NATO airbases is marginal. The SS-22 and the Scud missile lack sufficient accuracy to be effective in a conventional airfield attack role. Further, the SS-22 would not constitute a significant threat to airfields because limited numbers will restrict it primarily to the nuclear role. While the more accurate SS-21 is available in sizable numbers and continues to be deployed, its short range restricts its participation in the air operation to attacking the forwardmost elements of NATO's air defense system

with the projected deployment of the improved SS-23. When the Soviets develop effective munitions to complement the projected terminal guidance (50-meter CEP) capability of the improved SS-23, many of NATO's air defense aircraft could be pinned down for significant periods of time (figure 5). Airborne aircraft could be forced to recover at bases that may not have shelters or appropriate support facilities. The successor to the SS-22 is projected to be available only in limited numbers, and is primarily assessed to be employed in the nuclear role. Its range capability could allow the Soviets to target a few of the highest priority objectives in the eastern part of the United Kingdom.

76. Although the new generation of SRBMs provides the Soviets with targeting capabilities not previously available, there are weaknesses to the missile system operations which potentially can be exploited:

— *Command and Control.* The complexity of Soviet operations places a major burden on the command and control system. The scale and scope of Soviet operations are predicated upon complete integration of the forces, meticulous planning, exact timing, and precise execution. If

SRBM Conventional Warheads

(1) Unitary High Explosive.

(2) Improved Conventional Munitions.

(3) Fuel-Air Explosives (FAE).

(1) Area Denial Mine ICM.

(2) Runway Penetrator ICM.

Chemical Warheads

a. *General.* The Soviets have effective chemical agents for most tactical requirements. The primary nerve agents are soman (GD), sarin (GB), and probably a V-type agent. Soman is available thickened with 3- to 5-percent polymethyl-methacrylate (PMMA) and designated by the Soviets as VR-55 (not a V-type agent). The most probable chemical agents available for SRBM delivery are VR-55 or V-type agents in the "rain" mode, and GD for surface or near-surface delivery by submunitions. It is known that the Scud missile has a chemical warhead containing a toxic agent. A chemical warhead containing the same agent probably has been designed for the SS-21 warhead.

b. *Postulated Chemical Warhead Characteristics.*

There are indications of two possible chemical warhead types—ICM and a unitary bulk fill.

(1) *Chemical Submunition.* The most likely fill for a chemical cassette would be an agent such as soman. Fuzing could be impact or low-altitude (less than 30 meters) proximity, producing a vapor and aerosol cloud over a 350- to 500-meter-diameter impact pattern. As a result of the surface or near-surface dispersion, very little of the agent would be lost due to evaporation, and atmospheric drift would be minimized, and depending on wind velocity an entire area could be contaminated within a matter of minutes. A long-term inhalation hazard could persist for three to five days.

(2) *Unitary Warhead.* This type warhead would probably be filled with bulk VR-55 or a V-type agent (possibly binary) and fuzed for a 1,200- to 1,500-meter height-of-burst (HOB). This would produce an area of contamination of approximately 100 hectares (4.5 kilograms per hectare). At nominal temperatures (15 to 20 degrees C), contamination would persist for one to three days.

78. The SRBM threat will grow during the period 1985-95 with the deployment of the improved SS-23, which will have the requisite range and accuracy (50 meters CEP) to attack airfields. The degree of this threat will depend on the numbers of the system deployed, on other competing targets, and on whether specialized airfield attack munitions are developed. Improvements to the SRBM force will give the Soviets an option to employ it in a pin-down attack against some critical airbases and for neutralization of air defense sites in penetration corridors. Such attacks could significantly improve the chance of success of the initial massed air raid. Overall, while SRBMs will

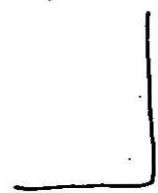
probably play a greater role in the air operation, we do not believe they will become in Soviet eyes the primary instrument for gaining air superiority in the NATO Central Region.

IV. SOVIET SPECIAL PURPOSE FORCES—  
SPETSNAZ

A. Introduction

79. Soviet special purpose forces constitute a significant threat to the airfields, nuclear delivery forces and storage facilities, air defense, and command, control,

~~Top Secret~~



Faint, illegible text in the center of the page, possibly bleed-through from the reverse side.

communications, and intelligence of the NATO Central Region. In wartime, they are intended to operate behind enemy lines, independent of regular Soviet forces, for extended periods of time, conducting reconnaissance, sabotage, and/or destruction of a wide variety of key targets. The term Spetsnaz is most commonly used in reference to the special-purpose forces of the Chief Intelligence Directorate (GRU) of the Soviet General Staff. GRU Spetsnaz brigades are assessed to be in 11 of 16 military districts, in the Group of Soviet Forces in Germany, and probably the four fleets. The Central and Southern Groups of Forces and selected armies have Spetsnaz companies. Total peacetime strength of active Spetsnaz units is estimated at 11,000 to 13,000, with the potential wartime strength as high as 25,000.

### B. Missions

80. The primary mission of Spetsnaz troops in a theater war is to reconnoiter and report on activity at enemy airfields, nuclear storage sites, nuclear weapons delivery locations, and associated facilities. In order to accomplish this, Spetsnaz teams, which the Soviets call special purpose reconnaissance groups, would attempt to infiltrate into the target area immediately prior to and at the outbreak of hostilities and would seek to position themselves near their targets to facilitate reconnaissance or direct action operations. Clandestine agents already in the target area would provide intelligence and logistic support to the teams.

81. The transition to wartime operations would begin with reconnaissance of predetermined targets for reporting back via radio to the Front Intelligence Directorate. The decision to employ Spetsnaz teams in a direct action role would be made by command authorities at the front level or higher and would depend upon circumstances, including, for example, the nature of the target, the battle situation, the availability of other resources (rocket, artillery, or air attack) to respond rapidly, the value of continued Spetsnaz reporting for repeat strikes by other forces, and the chances of the enemy immediately employing nuclear weapons. Some Spetsnaz teams may be initially assigned targets for sabotage rather than for reconnaissance. Also, teams assigned reconnaissance missions against mobile nuclear targets are probably authorized to attack these targets if launch appears imminent.



### C. Organization

85. Each military district that forms a front in wartime has a Spetsnaz brigade. At least three brigades would be of immediate concern to the NATO Central Region (figure 6). A Spetsnaz brigade is also believed to be present in the Baltic Military District but is yet to be precisely located. Spetsnaz brigades are reportedly organized as shown in figure 7. The headquarters company is staffed entirely by extended-term personnel, that is, officers and warrant officers. They are the best linguists in the brigade and are highly trained in sophisticated survival techniques. Soldiers of this company could be assigned to assassinate or kidnap key military and civilian leaders.

86. Spetsnaz unit strength is related to the various theaters of military operations in which they will operate. At present, the strength of an "average" brigade is assessed at approximately 700 personnel. During wartime, Spetsnaz brigade personnel and associated support agents for large fronts, such as GSFG, could number as many as 2,200. A Spetsnaz brigade at front could have approximately 100 teams of five to 12 soldiers each. Army-level companies are assessed as having as many as 10 subordinate teams. Those Spetsnaz brigades in the Western MDs and the GSFG that will form fronts against the NATO Central Region appear to be the largest. Considering that sizable NSWP special-purpose forces exist, albeit of mixed capability, we assess there could be approximately 300 to 500 Spetsnaz-type teams available for deployment against the NATO Central Region.

### D. Employment of Special Purpose Forces in the NATO Central Region

87. [

88. A small number of agents will be inserted covertly, disguised as civilians, before the beginning of hostilities. However, the vast majority of Spetsnaz will not cross the border before the beginning of conventional hostilities. The Soviets rely on the confusion of war, and the opening of penetration corridors during the air operation, to allow insertion of Spetsnaz by aircraft. Moreover, the detection of armed Spetsnaz inserted by aircraft before conventional hostilities could result in the loss of operational surprise.

89. [

90. Although there is limited evidence concerning the methods of attack a Spetsnaz unit might use against airfields, one source has revealed several methods taught at the Leningrad Military Academy. In the first method a Spetsnaz platoon of about 30 members was airdropped as close to the target as possible in the early evening hours. The unit was divided into a command team and four operations teams, each team with specific responsibilities including capturing vehicles and personnel for the purpose of infiltrating the target. Mines and Block Strelas (figure 8) were positioned during the night near the ends of the landing strip and other airfield facilities. Early in the morning, two teams from each end of the airfield conducted a rapid attack against exposed aircraft, personnel, and facilities. As aircraft began to take off, the implaced mines were automatically activated, destroying the aircraft in the air. The teams very quickly departed the target area, abandoned the captured vehicles, and hid in the woods during the day. During the night the

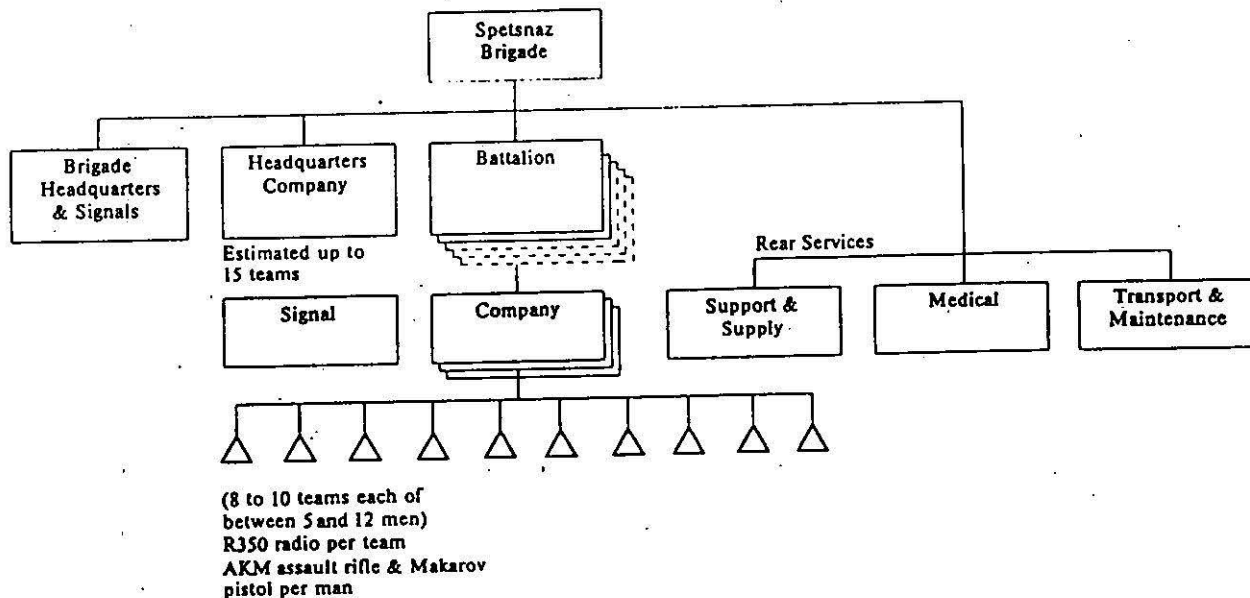
unit was resupplied with munitions and armaments by airdrop at a previously arranged location. Similar actions were repeated again the following night.

91. In a second method, a Spetsnaz company (approximately 10 teams of five to 12 men) operated against a heavily defended airfield. The company could not get closer than 2 to 3 km to the target. During the first night Block Strelas were positioned as close as possible to either end of the field, and then attacks were initiated against pipelines, powerlines, communication lines, security personnel, and crews heading toward the airfield. The intent was to create the impression of a significant force within the area. No activity was conducted during the second day or

night. During the third night strikes were conducted against aircraft in the open and against fuel dumps with standoff weapons (rockets) received during resupply

92. After a mission is complete, the teams may link up with follow-on forces, be airlifted out of the area if possible, or exfiltrate separately or in small groups back to their lines, destroying targets of opportunity along the way. The composition of a Spetsnaz team and the weapons and equipment used are dependent on the mission, means of infiltration, the nature and significance of the target, the security provided to the target, the amount of dispersal available in the enemy's rear, and the depth of the operation within the enemy's rear.

Figure 7  
GRU Special Purpose Troops (Spetsnaz) Brigade



~~Secret~~

93. [ ]

V. AIRBORNE AND AIR ASSAULT OPERATIONS

A. General

94. Airborne and air assault operations could pose a threat to NATO airfields, air defenses, and associated

facilities within the NATO Central Region. Early in the hostilities, targets would include forward-deployed forces and river crossing sites, and in the later stages of the offensive, targets would be deeper in the TVD. The employment of the airborne divisions would be controlled by the Supreme High Command, and would be dependent on limited Soviet military transport aviation lift capacity. Also, air superiority and the nature of the objective would influence the size of the airborne force to be employed.

95. Opposite the NATO Central Region are four front air assault brigades in the western MDs and GSFG, and nine air assault battalions. These units provide the theater, front, and army commanders with a flexible, well-armed force that could be used early in a conflict against targets in NATO's tactical depth, such as air defense assets, command, control, communications, and intelligence systems, and helicopter forward area arming/refueling points (FAARP), as well as occupation of key terrain and the destruction of tactical nuclear delivery systems.

#### B. Employment

##### 96. Airborne Divisions. [

Although the Soviets might opt for an airborne operation on the first or second day of the air operation, we believe they would wait until at least D+3 or later to ensure some degree of air superiority and the availability of transport aircraft. The Soviets might be more inclined to attempt an airborne operation early in hostilities against the NATO flanks, where NATO air and air defenses are less of a threat, in order to prevent NATO forces from diverting and shifting. The Soviets have significantly increased the ground mobility of their airborne divisions. All regiments now have the BMD airborne armored vehicle, which gives each division in excess of 350 armored fighting vehicles. In addition, each division is assigned its own artillery regiment as well as its own air defense battalion.

97. These increases in mobility and firepower have, in turn, increased Soviet airborne (VDV) lift requirements. Though Soviet transport aviation (VTA) has not increased the size of its transport fleet, VTA's continued deployment of more capable aircraft has continued to expand its lift capability. This expansion is expected to continue throughout the period of the Estimate, compensating for the increases in VDV

"heaviness." Currently, it takes approximately four to five VTA regiments to lift one airborne regiment. Because preparations for airborne operations provide significant indicators (marshaling of equipment—troops and aircraft, command, control, and communications), we believe future airborne operations will probably be of regimental size to reduce detectability and maintain the element of surprise. Because regimental-size operations are less aircraft intensive than are division-size operations, these operations will also ease the demands on VTA assets. This does not negate the fact that the Soviets could conduct a division-size operation if they deemed that the benefits of such an operation outweighed the inherent risk.

98. *Air Assault Brigades/Battalions.* Front- and army-level air assault units will be used early in the conflict to secure key terrain, raid command, control, communications, and intelligence installations, and destroy nuclear delivery and air defense systems. The depth of employment may be up to 60 kilometers in an army-controlled operation. [

The limited fixed-wing transport assets at front level and competing requirements for VTA would influence the size of the operations. At present, the principal aircraft at front for conduct of an air assault operation are the MI-8 Hip and the MI-6 Hook.

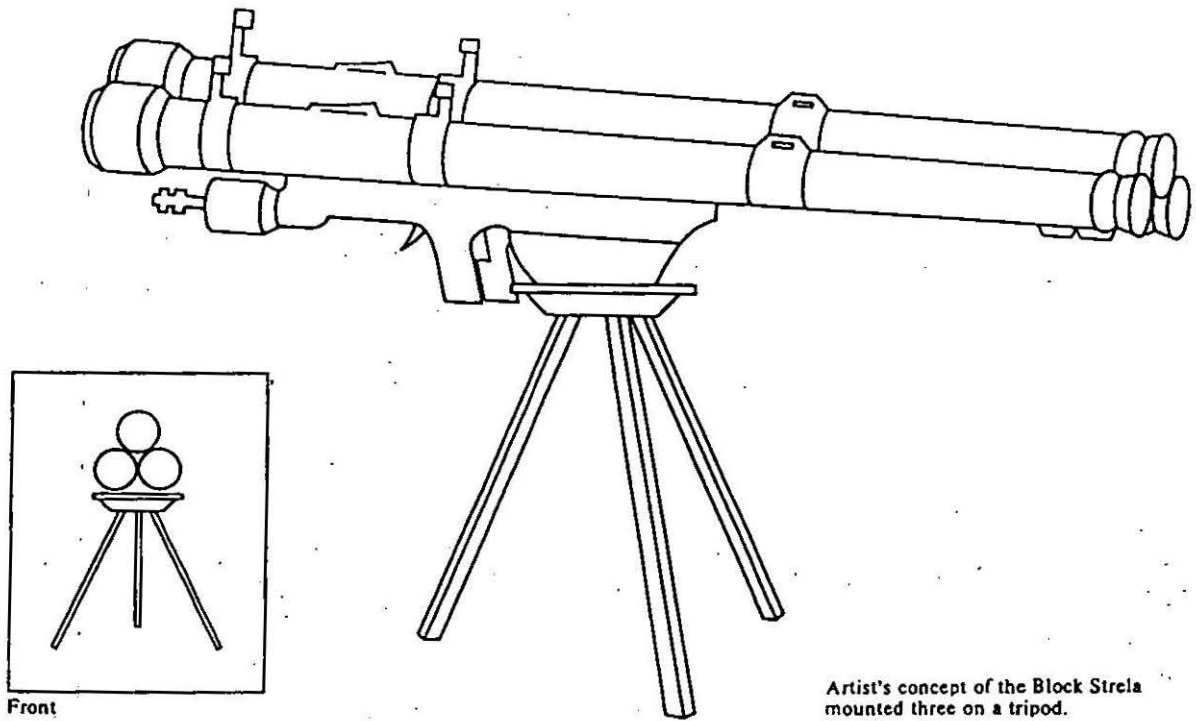
#### C. Airfield Attack

99. Airfield attacks can be made by airborne or heliborne forces, depending upon the distance from Pact forces. [

combination of an airdropped or heliborne initial assault force and an airlanded main force. Prior to the airborne assault, fighter-bombers or attack helicopters would provide initial preparation fire. The assault force, lightly equipped and armed, would drop, secure the runway, and eliminate remaining point defenses. Then the main body of the force would be airlanded, would complete elimination of resistance, and would secure the base.

100. Airborne attacks on NATO main operating bases (MOBs) are regarded as unlikely unless the Soviets obtain air superiority over at least a major segment of the Central Region. More likely would be

**Figure 8**  
**Three SA-7s Mounted on a Tripod**



Artist's concept of the Block Strela mounted three on a tripod.

~~Secret~~

000077-0-01

attacks by air assault troops on small civilian and military airfields just in front of advancing Soviet forces to secure airheads.

## VI. OPERATIONAL MANEUVER GROUPS (OMGs)

### A. General

101. The OMG is a concept for operations intended to conduct high-speed offensive operations deep into the enemy rear area. OMG operations are planned to disrupt the stability of the enemy rear, destroy major weapon systems, and facilitate the continuing advance of the first echelon and the commitment of the second echelon. Specific targets include nuclear delivery systems and depots, airfields, critical terrain, river crossing sites, and command posts. The OMG also may be used to interfere with mobilization and the movement of enemy reserves. The OMG can be employed at army or front level. It may be designated prior to an operation as part of the initial plan or during an operation to exploit an unforeseen opportunity. The OMG will normally be committed prior to the commitment of second-echelon forces.

### B. Missions

102. The OMG is normally committed through penetrations made by the first echelon in the enemy defenses with the mission of executing rapid and deep exploitation early in the offensive, disrupting enemy lateral maneuver and reinforcement; disrupting command, control, and communications and logistics; and seizing key objectives that will ensure the rapid advance of the main forces. These tasks require accurate and timely target reconnaissance and close coordination between OMG elements and other frontal forces. Airfields are probably important targets for OMGs, particularly their air assault elements.

### C. Employment

103. An army OMG may be committed on the first day or early on the second (about the time the first-echelon division is expected to break through the main defense). A front OMG probably will be committed on the third or fourth day (when the front's first-echelon armies attain their immediate objectives). The manner in which the OMG will come through the enemy's tactical defensive zone (first 50 km) will vary. Although the OMG may be introduced as a single force dispersed in width and depth, it is more likely that the

OMG will come through the defensive zone in at least two locations simultaneously to fragment enemy first-echelon forces and increase the difficulty for the enemy commander to identify the main attack. This tactic is intended to reduce the OMG's vulnerability to enemy air and nuclear attack.

104. There are two major offensive variations in how the operational maneuver group may be employed. An OMG may act somewhat in isolation, conducting operations well apart from the axes of the main effort and separate from the second echelon and reserves. An OMG may also be employed to execute encirclement operations.

105. Soviet military planners stress that assault by airborne and/or heliborne units is essential to the early success of deep operations by OMGs. These units must be inserted in sufficient numbers to secure critical objectives such as airfields, road junctions, bridges, and fording sites along the principal routes of advance of OMG forces and to disrupt the cohesiveness and integrity of enemy defenses. The Soviets anticipate that this activity would facilitate the OMG operations.

### D. Capabilities: Theory Versus Practice

106. High-speed deep operations by front and armies led by operational maneuver groups such as are required by Soviet doctrine would be extremely difficult for any commander to execute successfully. The timing of commitment, the dispersion, and the rate of advance envisioned for deep operations pose very complex problems for commanders and staffs in the areas of command, control, communications, and intelligence, and logistics. Intelligence must be extremely good if the group is to be committed when and where the enemy is least prepared to oppose it. Likewise, it will be extremely difficult to maintain command and control of a force that is widely dispersed in width and depth as it is committed, is deployed into subunits each with separate objectives, or attempts to link up with air assault units and with other groups moving on converging axes deep in enemy territory. Resupply of the OMG will require considerable air and ground cargo transportation assets, detailed logistics planning, and reliable ground and air-to-air defense to keep open supply corridors to OMGs on the advance.

### E. Force Developments

107. While there appears to be no fixed organization for an OMG, the New Type Army Corps (NTAC) may represent a possible solution and probably would

be used as a front OMG [

108. Should one or two additional NTACs be established in the WTVD for frontal operations, the NATO Central Region would be faced with the prospect of additional highly mobile forces that could be committed early in an attack to facilitate the front commander's plan of attack against NATO high-priority targets, such as the airfields, and to exploit weaknesses in NATO defenses.

109. Though not the primary threat, OMGs could attack NATO airbases in the early days of the war. This would occur if the airbase is within the OMG's zone of operation and the OMG advances sufficiently to reach the base. This could happen as early as day three or four of the war for an army OMG and day five or six for a front OMG.

## VII. CRUISE MISSILES, RECONNAISSANCE STRIKE COMPLEX, AND SURFACE-TO-AIR MISSILE THREATS

### A. Current Developments

110. The Soviets are presently developing two significantly different types of long-range land attack cruise missiles,<sup>11</sup> both of which are intended for nuclear attack. One is a family of subsonic low-altitude cruise missiles with an estimated range of about 3,000 kilometers. The second type is a supersonic-capable cruise missile [

111. There are three subsonic cruise missiles: the SS-NX-21 sea-launched cruise missile, the SSC-X-4 ground-launched cruise missile (GLCM), and the AS-15 air-launched cruise missile (ALCM). Deployment of the AS-15 began in 1984, with the SS-NX-21 and SSC-X-4 expected in 1985-86. The supersonic-capable SLCM, SS-NX-24, will probably be deployed

<sup>11</sup> A more detailed discussion of the long-range land attack cruise missiles can be found in NIE 11-3/8-84.

in the period 1985-86. A GLCM variant may also be fielded. The estimated payload, accuracy, and range of these missiles lead us to believe they will be nuclear equipped. (See tables 12 and 13).

### B. Future Developments

112. By the early 1990s Soviet long-range cruise missiles will probably have better CEPs (10 to 30 meters with area correlator update), longer ranges, lower radar and infrared observables, and improved engines and fuel types. A conventionally armed (high-explosive) cruise missile would facilitate attacks against airfields, air defense systems, and command and control facilities. If a high-explosive warhead is developed, however, the range of the missile would be reduced because of the heavier payload weight. By the mid-1990s, developments might include a highly advanced conventional warhead to destroy runways or a delayed action warhead to deny the use of runways. Chemical warheads could also be developed for these cruise missiles.

113. Currently, there is no evidence to indicate the Soviets are testing and developing medium-range cruise missiles. We believe, however, that by the early 1990s the Soviets probably will have tested and deployed medium-range cruise missiles as a result of spinoff technology from the current long-range cruise missile programs. It is possible that land attack cruise missiles armed with conventional warheads could be assigned to theater forces to assist in suppression of air defense missile sites and airbases, but we cannot assess the likelihood at this time.

### C. Reconnaissance Strike Complex System

114. Within the last several years the Soviets have been experimenting with the reconnaissance strike complex (RSC) system, which appears designed to counter US integrated systems for target acquisition and fire control. [

115. The RSC appears to have been developed out of Soviet concern for the threat posed by US long-range systems capable of delivering precision-guided munitions or submunitions and can provide fire support for forward-moving elements. It can engage mobile US long-range conventional strike systems, and can operate as an autonomous fire entity to engage ad hoc targets.

116. It is unlikely that the Soviets would use RSC: to attack NATO airfields. Airfields are large, fixed sites, and the locations of virtually all NATO military airfields already are known to the Soviets. [ ]

#### D. Surface-to-Air Missiles

117. Although it is unlikely, certain Soviet SAM systems could possibly be employed in emergency situations in a surface-to-surface role. We have no evidence, however, that the Soviets have conducted exercises or have tested land-based SAM systems in a surface-to-surface role. Evidence indicates only the SA-2 and SA-3 strategic SAM systems are capable of operating in a surface-to-surface mode but at significantly limited ranges—less than 40 kilometers. Neither the SA-5 nor the SA-10 strategic SAM systems has a surface-to-surface capability and as such does not pose a threat to NATO airfields, although the SA-5 strategic SAM system, such as deployed within CSFG, could be targeted against critical NATO airborne assets (AWACS, SR-71, TR-1).

118. The effectiveness of Soviet SAM systems is fully realized when utilized as designed—to acquire, track, and destroy airborne targets. Surface-to-surface use would be inefficient and severely constrained by inadequate warheads and limited range. We believe the limited surface-to-surface capability of the Soviet SAM systems does not presently pose a conventional threat to NATO airfields.



## VIII. AN ILLUSTRATIVE SCENARIO OF A WARSAW PACT NONNUCLEAR AIR OPERATION AGAINST NATO CENTRAL REGION AIRFIELDS

### A. General

119. The Warsaw Pact threat to NATO airfields is a subset of larger questions of control of the air and control over NATO's nuclear escalatory option. Pact planners believe that NATO's tactical air forces and nuclear weapons in the Central Region would be a formidable threat to a successful Pact offensive. Consequently, they consider that the Pact's early attainment of nuclear and air superiority would be essential. The Warsaw Pact plans to achieve air superiority and neutralize much of NATO's nuclear delivery capability by conducting a coordinated theaterwide nonnuclear air operation covering as much as the first week of the war.

120. The air operation is a combined arms operation consisting of a series of massed air raids executed in coordination with artillery, air defense forces, SRBM attacks, electronic warfare, Spetsnaz, and possible assaults by airborne and heliborne troops. Each massed air raid would be planned to achieve some degree of tactical surprise and would be launched through corridors cleared in NATO air defenses, principally by frontal assets.

### B. The Air Operation

121. In general, the Warsaw Pact would have available 2,600 to 4,100 fixed-wing aircraft to draw upon for air operations (see table 1 on page 14). On the basis of Soviet writings and exercise activity, we believe the Soviets would group and prioritize targets by type<sup>11</sup> (that is, nuclear related, conventional air, air defense, and command, control, communications, and intelligence) for the air operation. This plan calls for the commitment of air assets of the first-echelon fronts, assets of the Legnica and Smolensk Air Armies, and aviation of the Baltic Fleet. In addition, we believe they probably would redirect the Vinnitsa Air Army from the Southwestern TVD and could also commit the majority of the units of the front air forces from the Western MDs. Initial Soviet efforts would focus on creating about four main corridors through NATO air defenses. Front and army assets, to include aviation, missiles, rockets, artillery, and radioelectronic combat means, would play a major role in air defense suppression and the establishment of penetration corridors. (See figure 3 on page 13.)

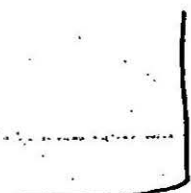
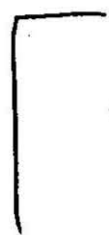
<sup>11</sup> See DIA study, DDB-1100-448-83-SAO, *Threat Assessment: Soviet Surface-to-Surface Missile (U)*, November 1983.

122. On the first day of the war, two massed raids are likely to be planned, but three raids would be possible. The main attack force would be strategic aviation units. The interval between the time one massed air raid commences and the next reaches NATO airfields could range from seven to 12 hours. However, additional attacks, primarily by frontal air forces, could occur during the interval. The number of massed raids would be reduced to one per day after the first two or three days of conflict.

123. The allocation of assets against specific objectives is determined not only by the relative priority of the objective but also by the ability of a particular weapon system to reach the objective (in terms of range and defense penetration capability). The sequence of employment of systems is determined by the requirement to deliver ultimately the greatest possible amount of firepower necessary to destroy or neutralize the highest priority targets. Thus, while nuclear-related objectives are the first priority for attack, the Pact would seek to suppress NATO air defense assets before using fighter-bombers and bombers against nuclear objectives. Therefore, front assets will provide principal support against air-defense-related objectives. The main strike force of fighter-bomber and bomber aircraft will be targeted against the high-priority nuclear and air superiority objectives.

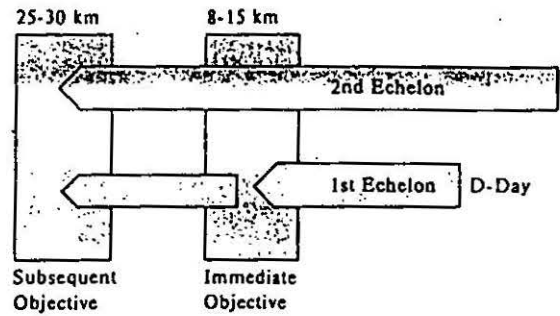
124. [

~~top secret Kurr~~

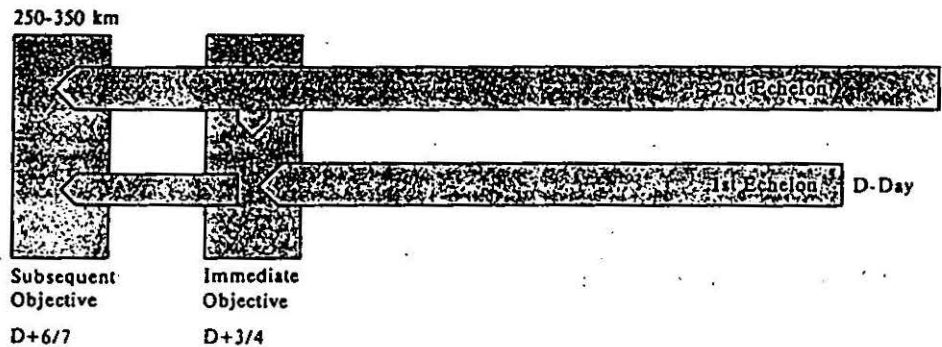


**Figure 10**  
**Warsaw Pact Offensive Operations**

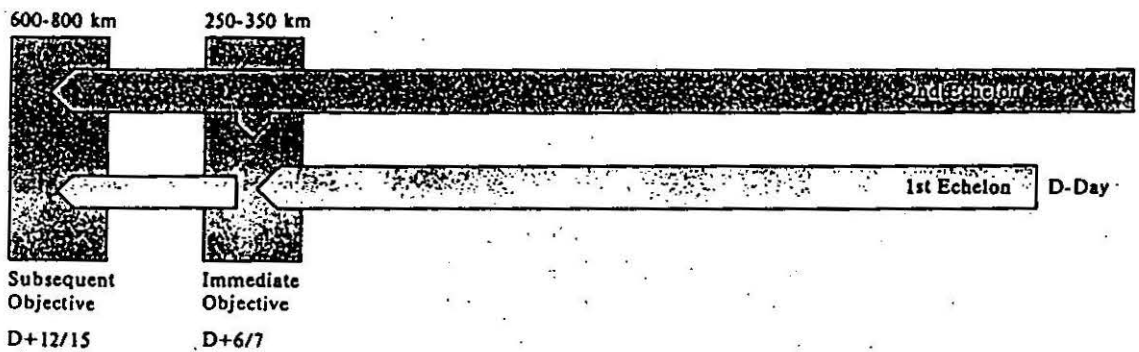
Division



Army



Front



Note: This represents a front operation. The Theater Strategic Operation consists of successive front operations conducted with little or no pause.

~~Secret~~

~~00014-9-81~~

~~TCS 5407-84~~

45  
~~Top Secret~~

125. During the air operations, current SRBM systems could pose a threat to a selected number of NATO airfields and associated facilities. Scuds and possibly SS-22s employed, just prior to the initial massed air raid could harass or temporarily disrupt NATO aircraft attempting to respond to the Soviet attack. Continued SRBM attacks could affect both sortie generation and recovery operations of selected NATO airfields. The short range of the SS-21 and FROG prevent their use against airfields in the Central Region at the beginning of the war. Currently, only about 30 percent of NATO airfields could be engaged with the SS-21 SRBM system by D+3 and about 65 percent by D+5 (figure 11). NATO airfields may also be suppressed or neutralized when in range of other indirect fire weapon systems (artillery and multiple rocket launchers) and, as shown in figure 11, there are NATO airfields which would be vulnerable to opposing forces artillery attacks within the first several days of the conflict.

126. We have no evidence that the Soviets would plan to employ chemical weapons during the air operations in the nonnuclear phase of a war with NATO. The use of chemical weapons is not a standard, integral feature of the nonnuclear phase of war. However, we cannot prudently discount the possibility of selective use of chemical weapons under certain conditions. Improvements in weapon systems might cause the Soviets to perceive that the selective employment of chemical munitions in conjunction with conventional munitions could assure the successful and early neutralization of NATO airfields and air defense systems. The selective employment of chemical munitions might be against only those air defense systems in the penetration corridors, specific airfields (air defense and ground attack), nuclear delivery systems (missiles and artillery), command and control systems, or combinations thereof. The Soviets may perceive that the risk of NATO nuclear retaliation would be offset by their own nuclear capability, leading them to the conclusion that NATO would not respond with nuclear weapons to the Pact's limited use of chemical weapons. The Soviets probably appreciate that surprise employment of CW could facilitate penetration of NATO defenses and assist in achieving the high rates of advance they consider necessary for victory in a short war. Also, they might see superiority in CW as providing them with a decisive advantage in an area in which NATO could not catch up during a short period of rising tensions. The protective posture and retalia-

tory capabilities of the enemy would figure prominently in Soviet considerations of the likelihood of the success of a chemical attack. A chemical attack against a NATO airfield ill prepared for such an event—not having the proper chemical protection and decontamination equipment and facilities—could severely disrupt operations if not entirely prevent them. On the other hand, they may determine that use of improved conventional munitions will provide better results while avoiding such consequences as the requirement to operate in a contaminated environment, the unpredictability of chemical weapons, or the risk of provoking an immediate nuclear response by NATO. The possibility of Soviet selective use of CW in the nonnuclear phase of war justifies serious consideration in any assessment of the Warsaw Pact threat to NATO.<sup>13 14</sup>

### C. Summary: Future Soviet Airfield Attack Capability

127. *General.* Current Soviet airfield attack capability suffers from a number of weaknesses. The first is the limited capability of current Soviet fighters to provide cover to their attack force. The second weakness is the limited capability of sensors and weaponry of current fighter-bombers. A third problem area is the marginal capability of current SRBMs in the airfield attack role. The fourth weak area involves the limited Soviet ability to direct the air operation. This is caused by deficiencies in the current command and control system that limit the size of the force that can

<sup>13</sup> This subject will be addressed in the upcoming SNIE 11/17-2-84, *The Soviet Offensive Chemical Warfare Threat to NATO.* (u)

<sup>14</sup> On the basis of the reporting of sensitive sources, CIA believes it unlikely that the Soviets would resort to the use of chemical weapons until a decision had been made to initiate nuclear warfare. Earlier use of chemical weapons would force the Soviets to balance the limited potential advantage of a chemical attack against the more dangerous probability of a NATO nuclear response. Additionally, sensitive sources report that the offensive use of chemical weapons is no longer a subject of study at higher Soviet military academies.

CIA also believes that the Soviets' use of the longer range missiles illustrated in figure 11 to deliver chemical munitions would deplete their inventory of potential nuclear delivery systems at the same time that they were increasing the likelihood of a NATO nuclear response. By the time the shorter range missile delivery systems had moved to within range of the airfields (80 to 100 km), those objectives would be under such conventional threat that chemical weapons would be of marginal benefit. Moreover, employment of chemical weapons at that range could slow the Soviets' advance by contaminating the battlefield and mandating dispersal in anticipation of a NATO nuclear response.

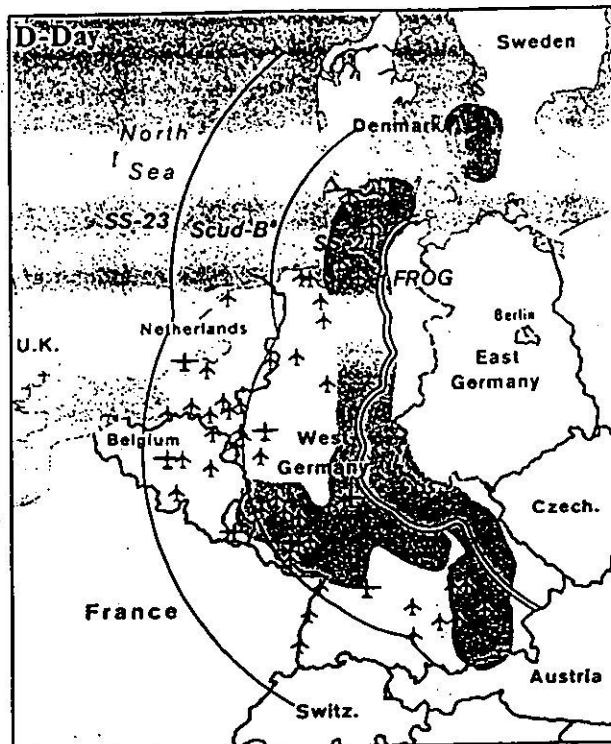


Figure 11  
Short-Range Ballistic Missile (SRBM)  
Capabilities

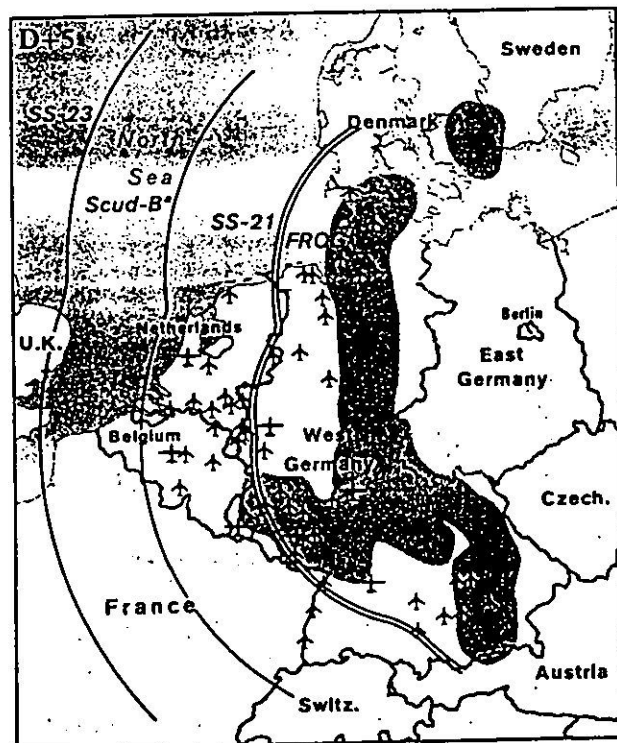
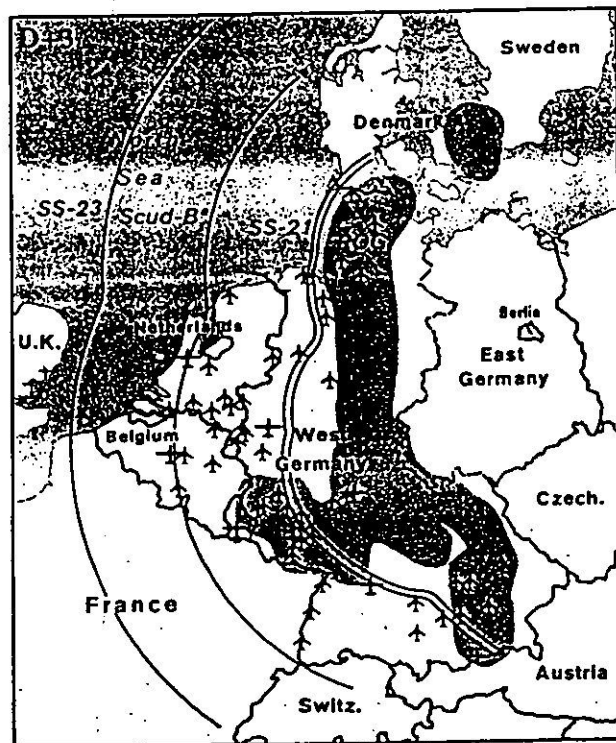
- ↑ NATO airbase
- ⊥ Airfield serving as aerial port of debarkation
- ▨ HAWK missile coverage against high-altitude targets

\* CIA believes there is a fielded, improved Scud with range approximating the SS-23.

~~Secret~~



Boundary representation is not necessarily authoritative.



1002175 (10-1990) 10-04

be effectively employed and directed, especially on NATO's side of the FEBA. We believe the Soviets are aware of these deficiencies and will make every effort to correct them.

128. *Aircraft* The numerical size of the air threat to NATO airbases will not change significantly by 1995. (See tables 5 and 14.) However, there will be major qualitative upgrades to the force, which will result in a significant increase in the capability of both the air-to-air and ground attack forces to carry out the airfield attack mission, particularly opposite NATO's Central Region.

129. *Fighters*. While we expect the number of dedicated fighters to decrease slightly, this will be more than compensated for by qualitative improvements, which will produce a more offensively oriented fighter force. Fighters deployed in the mid-1990s will be primarily Mach 2+ aircraft, with high maneuverability, able to conduct both close-in and beyond-visual-range attacks. These new fighters will possess lookdown/shootdown and multitarget tracking and engagement capabilities. Additionally, the new fighters will be armed with significantly improved air-to-air missiles. Future air-to-air missiles may feature ranges up to 150 kilometers by 1995. Semiactive radar and infrared sensors will probably continue to predominate, though there will be increased emphasis on fully active seekers. There is also the possibility of a totally passive radiometric seeker to counter stealth aircraft. Further, the Soviet fighter threat is expected to be enhanced by the development of an aerial refueling capability. These technological improvements, when coupled with improvements in Soviet pilot training, evolving Soviet doctrine, and the deployment of the Mainstay AWACS could lead to a significant Soviet capability to project fighters deep into NATO airspace. This could have a profound impact on the threat to NATO airbases by increasing the penetrability of the Soviet attack force.

130. *Fighter-Bomber/Bomber Force*. The Soviet attack force is expected to benefit from some growth in numbers. However, as in the fighter force, qualitative improvements will be more important. In aircraft, the primary improvement will involve the deployment of new aircraft with improved sensors which could allow accurate night/adverse-weather attacks. These aircraft will be capable of employing standoff, all-weather, precision-guided weapons. Future ground attack aircraft will also feature greater range and payload, and probably will be air refuelable enabling

**Table 14**  
Warsaw Pact Fixed-Wing Combat Aircraft Available for Use in the Air Operation in the Western Theater of Military Operations • 1995

Origin	Type	Numbers
<b>Primary participants</b>		
GSFG, CCF, Legnica AA, Smolensk AA, Baltic Fleet, and East German, Polish, Czechoslovak tactical Air Forces	Fighters	675/ 635 <sup>b</sup>
	Fighter-bombers	765
	Fencer type	210/ 300 <sup>b</sup>
	Medium bombers	385/ 240 <sup>b</sup>
	Reconnaissance/ ECM	425
<b>Subtotal</b>		<b>2,460/ 2,365<sup>b</sup></b>
<b>Probable participant if not committed to SWTVD</b>		
Vinnitsa Air Army	Fighters	100
	Fencer type	180
	Reconnaissance/ ECM	45
	<b>Subtotal</b>	<b>325</b>
<b>Total</b>		<b>2,785/ 2,690<sup>b</sup></b>
<b>Possible participants if Soviet Second-Echelon Front aviation participates</b>		
Baltic Military District Belorussian Military District Carpathian Military District	Fighters	640/ 600 <sup>b</sup>
	Fighter-bombers	360/ 415 <sup>b</sup>
	Fencers	150/60 <sup>b</sup>
Reconnaissance/ ECM		125
<b>Subtotal</b>		<b>1,275/ 1,200<sup>b</sup></b>
<b>Total</b>		<b>4,060/ 3,890<sup>b</sup></b>
<b>Likely nonparticipants</b>		
East German, Polish, Czechoslovak defense aircraft	Strategic interceptors	775
<b>Total</b>		<b>4,835/ 4,685<sup>b</sup></b>

\* Only about 85 percent of these totals would be available for sustained operations.

<sup>b</sup> Dual figures reflect DIA/CIA differences.

This table is Secret

deeper strikes to be conducted. Moreover, the penetrability of the airfield attack force will increase due to improved EW capabilities. These improvements will consist of more capable escort EW aircraft and more capable internal EW suites on Soviet aircraft.

131. *Tactical Air-to-Surface Missiles.* We believe future Soviet TASM's will have nominal ranges in excess of 50 kilometers with improved accuracy and improved night and adverse-weather capability. The missiles will feature lower launch altitudes and launch-and-leave guidance for increased aircraft survivability. Increased target frequency coverage will allow Soviet antiradiation missiles to attack both higher frequency radars and communications systems. These TASM's would be supplemented by Soviet bombers carrying improved air-to-surface missiles and conventionally armed cruise missiles.

132. *Conventional Munitions.* We estimate the Soviets will deploy more effective munitions for airfield attack, including a dual-stage runway penetrator bomb for increased runway damage, aerially delivered mines to hinder runway repairs, and precision-guided bombs with electro-optical seekers for attacking high-value point targets. With the expected deployment of new weaponry, when combined with improved aircraft, air attack remains the primary threat to NATO airbases.

133. *Short-Range Ballistic Missiles/Cruise Missiles.* In the future, SRBM's will supplement the air threat to NATO airbases in the Central Region. The SRBM threat, while currently marginal, will grow when the Improved SS-23 commences deployment during the period 1985-90. This missile will feature both the range and the accuracy to attack airfields. The degree of this threat will depend on the numbers of the system deployed and on whether or not specialized airfield attack munitions are developed. Because of the limited range, the currently fielded SS-21 Mod 2 will continue to pose a threat to only the forwardmost elements of NATO's air defense systems. (See table 15.) The Soviets may also develop cruise missiles optimized for nonnuclear airfield attacks, but this is unlikely to be a significant threat in the period of this Estimate.

134. *Command, Control, and Communications.* A major improvement in this area will be the deployment of the Mainstay AWACS, which will enhance Soviet air battle management. This system will give the Soviets the potential to extend low-altitude radar coverage deep into NATO territory. This will not only improve their potential to defend their territory, but

Table 15  
Western TVD SRBM Launcher Projections for 1995

	DIA and Army	CIA	Air Force
FROC-3/5	4	4	10
FROC-7	148	128	108
SS-21 Mod 1 <sup>a</sup>	0	0	48
SS-21 Mod 2	272	280	236
Scud-B <sup>b</sup>	86	104	80
SS-23	0	0	50
Improved SS-23 <sup>c</sup>	320	380	240
SS-22	0	0	0
Improved SS-22 <sup>c</sup>	90	0	48
SS-22 follow-on <sup>d</sup>	0	126	0
Totals	920	1,022	820

<sup>a</sup> Air Force believes the NSWP will be equipped with the SS-21 Mod 1 versus SS-21 Mod 2.

<sup>b</sup> CIA believes the majority of the Scud-B to be an improved version.

<sup>c</sup> DIA and Army believe the Improved SS-23 and SS-22 will reach IOC in 1985 and that there will be a more gradual expansion to 18 TEL brigades. Air Force believes the expansion to 18 TELs will be restricted to Soviet front-level brigades during the period of this Estimate. CIA and Air Force hold the IOC for the Improved SS-23 in the period 1988-90.

<sup>d</sup> CIA believes there will be a follow-on to the SS-22 versus an improved variant.

~~This table is Secret~~

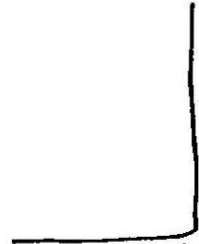
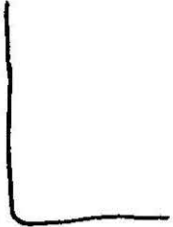
also, if used in an offensive mode, could improve the Soviet capability to project airpower deep into NATO's rear, especially by enhancing the ability of escort fighters to engage NATO air defense aircraft. The Soviets will also improve their command, control, and communications capability by continuing to emphasize communications security and resistance to jamming by fielding new technology. They will continue to improve both the capability and the capacity of their air-to-air communications. They will probably employ airborne use of communications satellites and extend their communications coverage into unused parts of the electromagnetic spectrum. The deployment of the AWACS and improvements in communications would give the Soviets an improved capability to project and direct airpower over NATO's airbases.

BLANK PAGE



ANNEX

Selected Bibliography



~~Top Secret RUFF~~

DISSEMINATION NOTICE

1. This document was disseminated by the Directorate of Intelligence. Because of the sensitive nature of some source material reflected herein, this copy is for the exclusive information and use of the recipient only.
2. This document may be retained, or destroyed by burning in accordance with applicable security regulations, or returned to the Directorate of Intelligence.
3. When this document is disseminated overseas, the overseas recipients may retain it for a period not in excess of one year. At the end of this period, the document should be destroyed or returned to the forwarding agency, or permission should be requested of the forwarding agency to retain it in accordance with IAC-D-69/2, 22 June 1953.
4. The title of this document when used separately from the text is unclassified.